



Scanned from the collections of
The Library of Congress



Packard Campus
for Audio Visual Conservation
www.loc.gov/avconservation

Motion Picture and Television Reading Room
www.loc.gov/rr/mopic

Recorded Sound Reference Center
www.loc.gov/rr/record

The TALKING MACHINE WORLD

For the
makers &
sellers of
talking
machines

Published Each Month by Edward Lyman Bill, Inc., at 373 Fourth Ave., New York, July 15, 1918



Victrola XVI, \$225
Victrola XVI, electric, \$282.50
Mahogany or oak

The instrument by which the value of
all musical instruments is measured





THE INSTRUMENT OF QUALITY

Sonora

CLEAR AS A BELL



Highest Class Talking Machine in the World

THE important reason why Sonora found favor so rapidly is because it is the finest phonograph that it is possible to make. Those with cultivated musical taste are content only with the best. *Quality* is studied in Sonora's production rather than a low price.

The reason why so many dealers select Sonora is because of its high reputation; it sells quickly and on a better cash basis, therefore with the Sonora line your bank balances grow. The Sonora is guaranteed to give satisfaction.

The buyer of a Sonora owns the instrument which won highest award for tone at the Panama Pacific Exposition.

If you are interested in selling the Sonora write us today.

\$50 \$55 \$60 \$75 \$120 \$135 \$175
\$190 \$215 \$230 \$300 \$375 \$500 \$1,000



THE GRAND

Art models made to special order to suit any taste

Sonora Phonograph Sales Company

INCORPORATED

GEORGE E. BRIGHTSON, President

Executive Offices: 279 Broadway, NEW YORK

Sonora is licensed under BASIC PATENTS of the phonograph industry



The Talking Machine World

Vol. 14. No. 7

New York, July 15, 1918

Price Twenty-five Cents

TALKER MUSIC TO LURE SEALS

State Fish Commissioner of Washington Declared to Be Working on Such a Plan—Will Be Possible to Take a Machine, Records and a Gun and Get a Sealskin for Better Half

SEATTLE, WASH., July 2.—If experiments now being conducted by the State Fish Commissioner's office here work out satisfactorily, it will soon be possible for the average citizen, handicapped by war expense, to simply grab his trusty rifle under one arm, talking machine under the other, climb into a skiff, paddle to the sealing grounds and grab off the makings of a sealskin coat for friend wife.

The State Fish Commissioner is a believer in the power of music, and is experimenting to see if the melody from a talking machine floating across the waters will not lure the seals within his reach. The plan is for the seal hunter to anchor near a rookery or salmon trap, put on a record and when the audience of seals gather, pick up his trusty rifle and kill off the audience.

One local talking machine dealer suggests that instead of using a rifle the hunter take with him a series of comic records, such as "Cohen at the Telephone," and permit the seals

to laugh themselves to death. By this means the skins will be preserved perfectly and will be in no danger of being marked by the bullets. It is declared, but not officially, that the State Commissioner got his original idea from seeing sealskin coats on women attracted into tango parlors by the ravings of jazz bands.

BOOKS SHOULD BE KEPT

Every Concern Paying Taxes Should Keep a Record of the Business Transacted—Is Part of Revenue Act—Power of the Commissioner

One fact about the revenue act that has pretty well escaped notice is that it gives the Treasury Department power to enforce the keeping of records in every concern that pays any of the taxes the act provides for, and to say what kind of records they shall be. Here is the law: "Section 1001. That . . . every person, corporation, partnership, or association, liable to any tax imposed by this act, or for the collection thereof, shall keep such records as the Commissioner of Internal Revenue, with the approval of the Secretary of the Treasury, may from time to time prescribe." The Commissioner has made no plan as yet for exercising this authority.

ATTITUDE OF SALESMAN TO BUYER

Simplicity, Sincerity and Directness Are Qualities That Will Win Respect

It has been said that the salesman should seek to place himself upon the level of the customer in his conversation with the latter. Such advice, we believe, is likely to be misunderstood. To carry on a conversation, to make a sale of goods, deliver a lecture or preach a sermon, it is not necessary to be either a high-brow or a tough. In attempting to take another person's level one is likely to fall below it. It is much better in all relations of life to cultivate simplicity, sincerity and directness, and to be one's self.

These qualities inspire respect whether one's customer be a college president or a laborer. The salesman is aided in this by the fact that he is likely to be more successful if he is a good listener. Good listening frequently implies more than good speaking, for it means appreciative understanding of what another is saying and an attitude of interest which is always complimentary to a speaker.

While the salesman should be a good listener, he need not be altogether a silent listener, says Office Appliances. He should talk enough to consummate the sale after his listening qualities have commended him to the customer, but not so much as to kill a sale which judicious economy in conversation would have made possible.

Music and Patriotism Combined Prove a Profitable Investment

ALBANY, N. Y., July 8.—When Governor Whitman signed the Chaplains' Outfit bill last year little did he realize how far-reaching would be the effect of his kindly act, even though he foresaw the need of clean, wholesome enjoyment for our boys in camp.

Upon his shoulders rests the pleasant responsibility for the many hours of pleasure which the New York State troops, now in Federal service, enjoy at their various posts, both at home and abroad.

The Chaplains' Outfit, one of which was given to each of the New York State troops, consisted of one Ford truck, forty-eight camp stools, one folding organ, one folding table, one folding typewriter, moving picture outfit, and last, but by no means least, one Victrola and twenty records (forty selections) in carrying case, the latter being popularly known as the Gately Army and Navy Outfit.

John L. Gately, president of the Gately-Haire Co., Inc., Albany, N. Y., lent his commercial knowledge and experience in the buying of some of the outfit articles, and from the letters he has received from the various chaplains, who are loud in their praise of the outfits, it is safe to say that, in the thoughts of our soldier laddies, Governor Whitman's stock has gone up 100 per cent. for his foresight, humanity and evident love of music.

A letter from one of the chaplains read as follows: "The machine has done splendidly and is very satisfactory. I would be very glad indeed to have some new records but I have no money to pay for them. If, as I interpreted from your letter, you hope to get authority to send more records, I shall be delighted to receive them."

An officer in one of the companies writes: "The evenings' are very lonesome, as most of the men stay in their tents at night. A Victrola shortens the distance from home and makes them very happy."

The good example of Governor Whitman—pioneer in his thought for the welfare and social enjoyment of the boys—has been followed by Governors of some of the other States. Governor Brumbaugh, of Pennsylvania, is enthusiastic

over the merits of music in connection with military affairs. In fact, he has just issued a proclamation urging the organization of marching and singing clubs to arouse the nation.

Some of the States have equipped all of their armories with an outfit similar to the Gately Army and Navy Outfit, and it is reasonable to believe that, in the near future, others will see the importance of this form of entertaining for the boys, and the Victrola will be made a unit in the list of Quartermaster supplies just as surely as the most important necessity. As the company possesses a library, so will it have its Victrola and records in the future.

How can the long tedious hours that are part of the life of a soldier be lightened more effectively than by the aid of clean, wholesome books and music that stirs the soul? Those of us who are here, in the safety and comfort of home, little realize what our boys "over there" are going through, on the road of "the great adventure." As Francis Rogers, the singer, well known of Albanians, who has just returned from a singing tour of the European camps, says: "A phonograph is the chief treasure of a Y. M. C. A. hut, and is usually working all day long—I might say that it is never silent. They even revel in gloomy songs, so great is their longing for music. I have sometimes seen a boy standing with his arms thrown lovingly about the machine and his ear to its mouth, drinking in the strains of 'My Laddie,' or 'Over There.' Sometimes the boys comfort themselves with what most of us would consider pretty depressing music, and are satisfied to play the same records over and over again. If this satisfies them, how much keener would be their enjoyment of new records from time to time.

"Without any sentimentalizing, music will do a great deal to win the war." This is the opinion of Mr. Rogers and his co-workers in the foreign Y. M. C. A. service, who know what they are talking about; and the official opinion of officers who agree that the men cannot be converted into fighting men without inner sustenance: a high degree of confidence, cheerfulness, courage and other morale-building elements.

PROGRESSIVE BERMUDA DEALERS

Thos. J. Wadson & Son, of Hamilton, Have Built Up a Large Victor Business

Victor talking machines and records are immensely popular in Bermuda, and one of the most enterprising dealers of that popular resort



T. J. Wadson, Son and Staff, Hamilton for Americans is Thomas J. Wadson & Son, of Hamilton, both members of the firm appearing in the photograph herewith, which was taken with the entire staff after a shipment of Victor goods had been received. Thomas J. Wadson & Son have built up an excellent business in Hamilton, and report an increasing appreciation of the Victor among the very best element in the community.

OPEN NEW EDISON DEPARTMENT

The Erie Camera & Phonograph Co. have opened an elaborate Edison phonograph department in their store at State and Seventh streets, Erie, Pa., and are advertising the department in a big way in the local newspapers.

The Putnam, Page Co., Victor wholesalers, of Peoria, Ill., have found more space necessary to carry on their business despite wartimes and, therefore, have taken over the entire third floor of their present building to be utilized for offices and storage space.

The American Man Is Gaining An Artistic Self-Respect By Means of The Talking Machine

It is not easy to measure the tremendous influence exercised by the talking machine in stimulating musical knowledge and appreciation in America. For years past *The World* has pointed out that no other factor has been so resultful in bringing music to the masses—the best in music—as the talking machine, and as a result there exists to-day a more widespread comprehension of what constitutes good music than ever before.

This is not only true as far as the women of America are concerned—who through their clubs are a most influential factor in developing American musical interests—but also among the men, who apparently in the past have been too busy to give music serious consideration.

As pointed out so very interestingly in *The Monitor*, of Boston, recently, talking machines have proved to be an especial opportunity for the American man. Authorities agree upon what talking machines have done toward popularizing the better class of music, but they overlook the fact that through them the American man is gaining an artistic self-respect. Though potentially quite as musical as the American woman, he has refused to develop along the lines which have succeeded with her, and has been half convinced that he is the more unmusical of the two. He has not had time to attain enough technical training to achieve musical self-expression, has been too busy to explore the mysteries of opera and symphony, and has refused pointblank to learn about music through books or clubs.

Consider a ranch far removed from the railroad. There stands a talking machine. At the dinner hour the men sit and listen, while record after record is played. A new record by a new artist must meet the approval of critical cowboys before it is listed with favorites, while a new record by a favorite artist is an event. One of these men would not understand your motives if you asked him about an author, Browning or Conrad or Mark Twain; but merely mention one of the great musical artists of the day, and instant friendship is established. His pronunciation of the performer's name may be crude, and the title of the composition may induce a smile, but he knows the music.

Neither the ideals of education nor the rigors of practical experience have completely blighted the American man's inherent musical possibili-

ties; and the degree of his knowledge may be observed in the training camps for United States soldiers. A technical investigation of the musical capacity of the soldiers is not necessary. One may quickly find out what they know or do not know by noticing how they take the work of a great performer who visits them.

Recently, Mme. Maud Powell, the violinist, played in several camps in the course of her

It May Be Safely Assumed That Some New Influence is Reaching the Male Sex of America

tour in the Western part of the United States and Canada. No artist knows better than she the country included in the concert circuit of North America. For she has had to convince the people before whom she went, and in the process she has learned of what stuff they are made. She, of course, approached her task of playing at the camps with a sincere desire to please the boys, but knew that pleasing them did not mean lowering her standards. She was genuinely surprised when the boys would ask for favorites—favorites of hers. A soldier from Oregon would call for one thing, a soldier from Montana for another; they knew Mme. Powell, and they knew the music also.

Mme. Powell found that wherever she played men knew her and her violin pieces whether they came from city or country. The manager of one theatre was quite convinced the soldiers would not listen to a woman "fiddling classical stuff," and did his utmost to persuade her to play the lightest program her conscience would permit, almost insisting that a disagreeable failure would ensure if she had her way. She told him she knew what the boys wanted and she

won them, much as she wins her regular audiences. Extra numbers were called for without a moment's hesitation as to the name of the number desired.

American men have lacked confidence; they are music shy. The talking machine gives them an opportunity to listen casually. They listen and learn without wasting time at a concert. A man may sit alone and listen, if he no longer fears detection and ridicule from the family. One day he upsets all precedent by offering an opinion regarding a singer. Slowly the sifting process goes on until he has acquired high standards.

This process is country-wide in its operation. What Mme. Powell discovered on her tour is being called to the attention of all observers. An elderly man was following two small lads in a Western city. The boys were having a heated argument, and the kindly gentleman became interested enough to approach closer, so as to overhear the cause of the contention. One boy, about ten years of age, said that anybody who did not think Melba's "Caro Nome" was the best singing, had a lot to learn; and the other lad declared flatly that it did not hold a candle to "Why Do the Nations?" by Witherspoon. The elderly man retreated, lest he should be called upon to settle a dispute about which he knew nothing. When American boys argue on the streets over the merits of Melba and Witherspoon, it may safely be assumed that some new influence is reaching American men.

THOR NORBERG NOW AN ENSIGN

Talking Machine Dealer of Moline, Ill., in Charge of Physical Training at Great Lakes Naval Station—Doing Most Successful Work

Thor Norberg, successful Victor talking machine dealer in Moline, Ill., and who also conducts a store in Rock Island, has entered the U. S. Naval Service with the rank of ensign, and is now in charge of physical training at the Great Lakes Naval Station. Mr. Norberg is a native of Sweden, but a citizen of the United States, and his work in building up the physique of Uncle Sam's new sailor lads has been commended by his superiors. Meanwhile, the business has been left in competent hands and is prospering.

SINCERITY

That's the slogan back of every factor in

Ditson Service

It means much just now

Oliver Ditson Co.
BOSTON

VICTOR
Exclusively

Chas. H. Ditson & Co.
NEW YORK

Victrola VI-A, \$32.50
Oak



Victrola IX-A, \$60
Mahogany or oak



Victrola XI-A, \$115
Mahogany or oak



Victrola XVI, \$225
Victrola XVI, electric, \$282.50
Mahogany or oak

Victor Supremacy

Victor supremacy points the way to success for every music retailer.

It marks the "path of least resistance."

Victor Talking Machine Co.
Camden, N. J., U. S. A.

Berliner Gramophone Co., Montreal, Canadian Wholesalers

"Victrola" is the Registered Trade-mark of the Victor Talking Machine Company designating the products of this Company only.

Warning: The use of the word Victrola upon or in the promotion or sale of any other Talking Machine or Phonograph products is misleading and illegal.

Important Notice. Victor Records and Victor Machines are scientifically co-ordinated and synchronized in the processes of manufacture, and their use, one with the other, is absolutely essential to a perfect reproduction.



Victor Wholesalers

Albany, N. Y....Gately-Haire Co., Inc.
Atlanta, Ga.....Elyea-Austell Co.
Phillips & Crew Piano Co.
Austin, Tex.....The Talking Machine Co., of
Texas.
Baltimore, Md....Cohen & Hughes.
E. F. Droop & Sons Co.
H. R. Eisenbrandt Sons, Inc.
Bangor, Me.....Andrews Music House Co.
Birmingham, Ala.Talking Machine Co.
Boston, Mass.....Oliver Ditson Co.
The Eastern Talking Machine
Co.
The M. Steinert & Sons Co.
Brooklyn, N. Y...American Talking Mch. Co.
G. T. Williams.
Buffalo, N. Y.....W. D. & C. N. Andrews.
Neal, Clark & Neal Co.
Burlington, Vt....American Phonograph Co.
Butte, Mont.....Orton Bros.
Chicago, Ill.....Lyon & Healy.
The Rudolph Wurlitzer Co.
Chicago Talking Machine Co.
Cincinnati, O.....The Rudolph Wurlitzer Co.
Cleveland, O.....The W. H. Buescher & Sons
Co.
The Collister & Sayle Co.
The Eclipse Musical Co.
Columbus, O.....The Perry B. Whitsett Co.
Dallas, Tex.....Sanger Bros.
Denver, Colo.....The Hext Music Co.
The Knight-Campbell Music
Co.

Des Moines, Ia....Mickel Bros. Co.
Detroit, Mich.....Grinnell Bros.
Elmira, N. Y.....Elmira Arms Co.
El Paso, Tex.....W. G. Walz Co.
Honolulu, T. H....Bergstrom Music Co., Ltd.
Houston, Tex.....Thos. Goggan & Bro.
Indianapolis, Ind..Stewart Talking Machine Co.
Jacksonville, Fla..Florida Talking Machine Co.
Kansas City, Mo...J. W. Jenkins Sons Music Co.
Schmelzer Arms Co.
Lincoln, Nebr....Ross P. Curtice Co.
Little Rock, Ark..O. K. Houck Piano Co.
Los Angeles, Cal..Sherman, Clay & Co.
Memphis, Tenn....O. K. Houck Piano Co.
Milwaukee, Wis...Badger Talking Machine Co.
Minneapolis, Minn.Beckwith, O'Neill Co.
Mobile, Ala.....Wm. H. Reynolds.
Montreal, Can....Berliner Gramophone Co.,
Ltd.
Nashville, Tenn....O. K. Houck Piano Co.
Newark, N. J.....Price Talking Machine Co.
New Haven, Conn.Henry Horton.
New Orleans, La...Philip Werlein, Ltd.
New York, N. Y...Blackman Talking Mach. Co.
Emanuel Blout.
C. Bruno & Son, Inc.
I. Davega, Jr., Inc.
S. B. Davega Co.
Charles H. Ditson & Co.
Lindsay Bros., Inc.
New York Talking Mach. Co.
Ormes, Inc.
Silas E. Pearsall Co.

Omaha, Nebr.....A. Hospe Co.
Mickel Bros. Co.
Peoria, Ill.....Putnam-Page Co., Inc.
Philadelphia, Pa..Louis Buehn Co., Inc.
C. J. Heppie.
The George D. Ornstein Co.
Penn Phonograph Co., Inc.
The Talking Machine Co.
H. A. Weymann & Son, Inc.
Pittsburgh, Pa...W. F. Frederick Piano Co.
C. C. Mellor Co., Ltd.
Standard Talking Machine Co.
Portland, Me.....Cressey & Allen, Inc.
Portland, Ore....Sherman, Clay & Co.
Providence, R. I...J. Samuels & Bro., Inc.
Richmond, Va....The Corley Co., Inc.
W. D. Moses & Co.
Rochester, N. Y...E. J. Chapman.
The Talking Machine Co.
Salt Lake City, U. Consolidated Music Co.
The John Elliott Clark Co.
San Antonio, Tex.Thos. Goggan & Bros.
San Francisco, Cal.Sherman, Clay & Co.
Seattle, Wash....Sherman, Clay & Co.
Sioux Falls, S. D..Talking Machine Exchange.
Spokane, Wash....Sherman, Clay & Co.
St. Louis, Mo....Koerber-Brenner Music Co.
St. Paul, Minn....W. J. Dyer & Bro.
Syracuse, N. Y....W. D. Andrews Co.
Toledo, O.....The Whitney & Currier Co.
Washington, D. C. Cohen & Hughes.
E. F. Droop & Sons Co.
Roht. C. Rogers Co.

ALL RECORD CUSTOMERS ARE ALBUM CUSTOMERS



MAKING THEIR SELECTION

A Place for Every Record and Every Record in its Place

Albums are an **Indispensable Requisite** in the talking machine business and wherever records are sold. Practical and handy. Save time and records. A **profitable adjunct** to the business.

We manufacture disc Record Albums to fit cabinets of all sizes and styles. With the indexes they are a complete system for filing all disc records.

We have unexcelled manufacturing facilities, and considering quality our prices are the lowest. Write us, giving quantity you may desire, and we will quote prices.

OUR ALBUMS ARE MADE TO CONTAIN VICTOR, COLUMBIA, EDISON, PATHÉ AND ALL OTHER DISC RECORDS

NATIONAL PUBLISHING CO., 239 S. American St., PHILADELPHIA, PA.

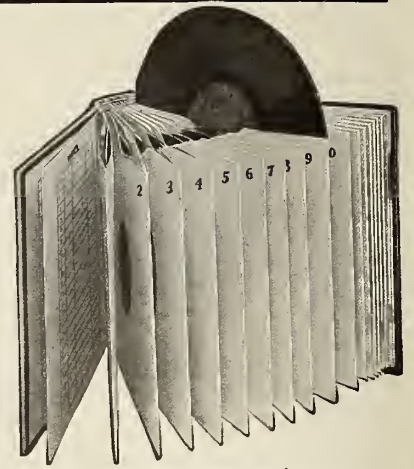

THE PERFECT PLAN

CONDITIONS IN TALKING MACHINE TRADE IN AUSTRALIA

Machines and Records Not So Numerous in That Country as in the United States, and Most of Them Are Imported From England and This Country—Unusual Conditions That Prevail

WASHINGTON, D. C., July 6.—The following interesting report regarding the situation in Australia in the matter of talking machines and records has been made by Howard A. Treat, secretary to the commercial attaché in Melbourne:

Although there are a good many "talkers" in use in Australia, they are by no means so common as in the United States; and while there are some cheaper grades assembled in Australia from imported parts, the majority of the machines on sale here now are shipped from England and America. Before the war some French and German makes were sold.

Customs receipts for the fiscal year ended June 30, 1917, show that talking machines to the value of £55,000 (\$267,600) were imported from the United States. During the continuance of the war other countries are practically out of the market. The duty on talking machines of other than British manufacture is 10 per cent. ad valorem. It is understood that the small manufacturers who assemble parts into cheap machines desire to have this duty increased for the protection of home industry.

No energetic effort has been made to push the sale of talking machines until within the past year. Hitherto phonographs have been carried as a side line by dealers in pianos and other musical instruments, and until recently no one has undertaken to handle them exclusively. A Melbourne firm which carries nothing but talking machines states that within the past year it has imported 300 machines of the make it handles, and it further states that the more expensive styles sell more readily than the cheaper grades. The attempt to sell the more expensive cabinet machines is a comparatively recent venture, as formerly the horn machine was the favored type. As yet the talking machine trade is in its infancy in Australia, and there is a good opportunity for the introduction of such instruments, for the people are very musical; but owing to the lack of development of this trade, piano players, which are much more expensive, have gained the preference.

The present is seemingly an opportune time for establishing a plant for the manufacture of

records in Australia. The situation here is peculiar. Australia is so remote from other countries that it comprises almost a world of its own in musical matters. Artists from Europe and America usually remain here many months, returning again and again to the same places if they become popular. Operettas, pantomimes, and musical comedies generally run from eight to ten weeks in each city. The rights to produce American and European musical successes in Australia are usually obtained soon after they become established at home, and local favorites present them in Australian theatres. Local musicians of ability are very popular, and visiting artists who meet with success are made much of, socially and otherwise, with the result that records made by such people would have a large sale if they could be made here and put out while the artists are at the height of their popularity.

Imported records sell at prices greatly in advance of those obtained in America, and records could be made here that would bring a lower price and still yield a good profit to the manufacturers. The sale of such records would do more toward increasing the use of talking machines than any other instrumentality. It is important, however, that the material of which the records are made be such as to insure a perfectly smooth surface and the best possible reproduction. Information as to the existence in Australia of raw materials for the manufacture of records is something that would have to be obtained by the manufacturers themselves, inasmuch as the composition of records is a trade secret.

RECREATION CENTER IN NEW YORK

The Y. M. C. A. Eagle Hut, which adds to the attractiveness of Bryant Park, New York, has been equipped with a talking machine by Reed Miller, the well-known singer. With a number of other artists Mr. and Mrs. Miller have been giving concerts at this recreation house, which have been attended by large numbers of soldiers and sailors.

THE SONORA IN AUSTRALIA

Allan & Co., of Melbourne, Are Handling and Featuring This Product in an Effective Way—A Leading Institution in the Antipodes

The Sonora Phonograph Sales Co. recently closed arrangements whereby Allan & Co., of Melbourne, Australia, will handle the complete Sonora line in this far distant point. The accompanying photograph will give some idea of the prominence accorded the Sonora line in Allan & Co.'s windows, and it is said that one of their beautiful windows will always be devoted to the exclusive display of the Sonora phonograph.

Allan & Co. is recognized as one of the foremost musical houses in the Antipodes and is



Allan & Co.'s Display Window, Melbourne frequently termed the "aristocrat" of the Melbourne musical houses. It is the oldest music house in that city, and caters to an exceptionally high-class clientele which will doubtless appreciate the merits of the Sonora phonograph.

The securing of a representation so desirable as that given by Allan & Co. enables the Sonora Co. to forego the necessity of introducing its product in this new field. The fact that the Sonora is being sold by the house of Allan & Co. is, for the Australians, sufficient guarantee of the unqualified merit of the product. Allan & Co. are planning to institute an aggressive campaign in behalf of the Sonora phonograph, and the outcome of this campaign will assuredly establish the position of the Sonora in Melbourne musical circles.

A LITTLE RECORD "POINTER"

A concern in the East which makes many collections for accounts of \$1 obtains prompt remittances, it finds, by the use of an envelope one inch by two inches in size, tipped with glue to the bill. On it is printed: "We have made it easy for you to remit. Just enclose \$1 in this envelope." The small size of the envelope seems to get more attention than the usual letter size, in spite of the fact that it cannot be mailed without a larger wrapping.

A Really Good Album At a Moderate Price is a Money Maker for the Dealer



METAL BACK ALBUMS

will give the dealer and his patrons true value and the highest quality. A complete line of albums that stand for the best in their respective grades.

Write for samples of our three numbers

NEW YORK ALBUM & CARD CO., 23-25 Lispenard St., NEW YORK

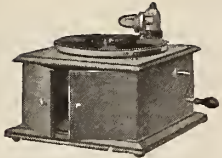

Victrola IV-A, \$22.50
Oak

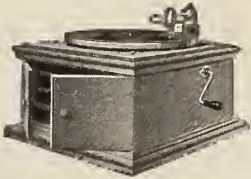

Victrola VI-A, \$32.50
Oak



Victrola VIII-A, \$50
Oak



Victrola IX-A, \$60
Mahogany or oak



Victrola X-A, \$90
Mahogany or oak



Victrola XI-A, \$115
Mahogany or oak

Victor Supremacy

The supremacy of the Victrola is as evident in the prosperity of Victor retailers as in the great musical accomplishments of the instrument itself.

Victor supremacy means retailer success.

Victor Talking Machine Co.

Camden, N. J., U. S. A.

Berliner Gramophone Co., Montreal, Canadian Wholesalers



Victrola XIV, \$175
Mahogany or oak



Victrola XVI, \$225
Victrola XVI, electric, \$282.50
Mahogany or oak



Victrola XVII, \$275
Victrola XVII, electric, \$332.50
Mahogany or oak

"Victrola" is the Registered Trade-mark of the Victor Talking Machine Company designating the products of this Company only.

Warning: The use of the word Victrola upon or in the promotion or sale of any other Talking Machine or Phonograph products is misleading and illegal

Important Notice. Victor Records and Victor Machines are scientifically co-ordinated and synchronized in the processes of manufacture, and their use, one with the other, is absolutely essential to a perfect reproduction



"HIS MASTER'S VOICE"

REG. U.S. PAT. OFF.

The **TALKING**
MACHINE
WORLD

*For the
makers &
sellers of
talking
machines*

PUBLISHED BY EDWARD LYMAN BILL, Inc.

President, C. L. Bill, 373 Fourth Ave., New York; Vice-President, J. B. Spillane, 373 Fourth Ave., New York; Second Vice-President, J. Raymond Bill, 373 Fourth Ave., New York; Secretary and Treasurer, August J. Timpe, 373 Fourth Ave., New York.

J. B. SPILLANE, Editor

J. RAYMOND BILL, Associate Editor

AUGUST J. TIMPE, Business Manager

Trade Representatives: B. BRITTAIN WILSON, L. M. ROBINSON, WILSON D. BUSH, C. CHACE, E. B. MUNCH, L. E. BOWERS, A. J. NICKLIN, V. D. WALSH

Boston: JOHN H. WILSON, 324 Washington Street

Chicago Office: E. P. VAN HARLINGEN, Republic Building, 209 South State Street. Telephone, Wabash 5774

London, Eng., Office: 2 Gresham Buildings, Basinghall St. W. LIONEL STURDY, Mgr. The Talking Machine World has regular correspondents located in all of the principal cities throughout America.

Published the 15th of every month at 373 Fourth Ave., New York.

SUBSCRIPTION (including postage): United States, Mexico, \$2.00 per Year; Canada, \$2.25; all other countries, \$3.75. Single copies, 25 cents.

ADVERTISEMENTS: \$4.50 per inch, single column, per insertion. On quarterly or yearly contracts a special discount is allowed. Advertising pages, \$125.00.

REMITTANCES should be made payable to Edward Lyman Bill, Inc., by check or Post Office Money Order.

NOTICE TO ADVERTISERS.—Advertising copy should reach this office by the first of each month. By following this rule clients will greatly facilitate work at the publication headquarters.

**Long Distance Telephones—Numbers 5982-5983 Madison Sq.
Cable Address: "Elbill," New York.**

NEW YORK, JULY 15, 1918

DESPITE the tremendous sums of money required to meet the nation's expenses the coming year, there is a magnificent feeling of confidence evident everywhere that we are coming out ahead, not only in victory over the enemies of the United States, but in the development of a greater and finer civilization which will follow our present days of travail. Nature is aiding and abetting in this feeling of confidence for latest reports from the Department of Agriculture convey the cheering assurance of a bumper wheat crop this year that promises to develop before harvest is finished into a production of a million bushels.

This is great news, not only for members of this industry, but for everyone interested in American trade and progress. It means more bushels of wheat than in any year except one, and better still, it indicates more bushels of oats, more bushels of rye, more bushels of barley than ever before—items that will bring cheering news to all the Western nations linked with us in the fight for world freedom, as well as to ourselves.

No less encouraging is the state of the cotton crop, the acreage and condition of which for the season are largely above the average. With three hundred million more bushels of wheat this year than last, and the ships to carry it, no worry need be felt over the food supply for our soldiers and sailors, as well as for our allies. Consider also that the vast wealth coming from the ground and which goes into the hands of our farming community will mean increased buying power. There can be no question but that the talking machine industry will get its share of this surplus wealth, inasmuch as talking machines and records are recognized as an absolute need in these days of stress.

It is in very truth a time for confidence, courage, and optimism rather than gloom and grouch. Americans young and old are all prepared, or are preparing, to meet every emergency that is necessary to supply the nation's needs. The great essential to-day is confidence. We must have confidence in the stupendous enterprise which is being conducted by this country in helping to bring freedom to the world. We must have confidence in the nation's ability to adjust business affairs to the end that industry is maintained unhampered only with such restrictions or changes as are inevitable in face of war necessities.

We must arouse public sentiment to a full appreciation of our power not only to do things, but to do them right. Instead

of talking depression and disaster and going around with bowed heads and sorrowful mien, is it not the time to exult and to take pride in the nation's manhood, in the nation's resources, and in its ability to triumph over all difficulties? Let us inspire confidence not only among our own people, but let us inspire confidence in those nations who are leaning on us for support.

READERS who are interested in the problems of price stabilization will find the views of Joseph E. Davies, former Commissioner of Corporations, and first chairman of the Federal Trade Commission, which appear elsewhere in *The World*, worthy of close consideration.

Mr. Davies places himself absolutely on record as being impressed with the necessity of doing justice and giving proper governmental protection to the manufacturer who produces standard goods of fine quality, behind which he places his name and reputation, and for which he has created a valuable goodwill by great and conscientious effort, believing by so doing that public interest is conserved. He points out that under existing law, as laid down by recent decisions of the courts, practices have become prevalent which constitute a menace to legitimate business interests, and are likewise a serious injury to the consuming public.

He emphasizes the need for legislation such as that which is covered in the Stephens Bill, now before the House of Representatives for consideration, after being amended, which will repose in a governmental agency, such as the Federal Trade Commission, the power, upon its own initiative or upon complaint, to review and adjust equitably the terms of the resale contract. In this connection he says: "With such a provision included the Stephens Bill would, in my judgment, secure to producers, distributors and the public all the benefits and economies of price stabilization on standard merchandise, and at the same time afford every possible protection of the public interests."

The views of Mr. Davies on the subject of price maintenance are of national importance. While chairman of the Federal Trade Commission he made a deep study of trade conditions, and a statement of his views regarding the Stephens Standard Price Bill, and the modifications that may seem necessary and desirable for an equitable solution of the whole question of resale regulation on identified products, is most timely.

TALKING machine dealers are facing big problems these days. Everything is topsy turvy; the greatest war in history is upsetting and demoralizing established practices in almost every field of effort, and it is difficult, if not impossible, to plan ahead with any degree of certainty. It is, however, a time for concentration, and this means well directed effort. The man who wins is he who devotes himself directly to mastering the difficulties that confront him.

This brings up the subject of summer trade, and it must not be overlooked that the talking machine, with its wonderful entertaining possibilities, is a potent trade stimulator during the vacation period. Why not concentrated action along this line? Get right down to brass tacks. Analyze your stock, which, despite its limitations, has undoubtedly possibilities for exploitation. Of course we are in war times, and there are many obstacles in the way of business expansion, but success is inevitable if one works earnestly for it. Keep in mind that the men who have reached the top of the ladder in every line of effort are the ones who have concentrated, and who have fought difficulties intelligently and persistently.

The more one studies the entertaining and musical features of the talking machine, the more admiration it excites. This is a subject on which dealers could dwell to advantage in summer as well as in winter. It means increased income earning power if a little more enthusiasm, ginger if you will, is placed in their work. There are still abundant opportunities in the matter of summer trade, although it may mean development along new lines and new channels.

This is the time of the year when all the world is out of doors and the great big national entertainer is the talking machine. This is not only true where soldiers and sailors congregate in the camps and "huts" in this country and in the trenches on the battle front, but it is also true of the summer hotels, camping out parties, country homes and clubs—in fact, talking ma-

chines and records are an absolute necessity wherever the best form of entertainment is desired. The talking machine to-day is truly a marvelous creation, and the more you analyze it, the more you go into the subject, the more it impresses.

Develop new trade in war time—in hot weather? Of course you can, and plenty of it—provided a fair amount of stock is carried. That's the rub!

Despite restrictions, curtailment, labor conditions and the increased demand for talking machines and records, manufacturers are making the greatest possible efforts to meet the requirements of the trade. For this is a time that calls for the highest form of ability in the production end. Manufacturers, it must be remembered, are facing problems that are not easy of solution. We must all conceive of the extraordinary conditions prevailing and be sufficiently elastic and considerate in our views to realize that every manufacturer is doing his best to look after the needs of his customers.

AN excellent suggestion comes from the Talking Machine Dealers' Association of Buffalo to the effect that secretaries of the various trade organizations exchange reports at their meetings in order to bring about a closer co-operation between the many local associations that have sprung up and are now existing in the trade and provide for a greater unity of action on matters of general import. Of course, the reports of the meetings of the various associations appear regularly in *The Talking Machine World*, and those interested can thereby keep in touch with what the different organizations are doing. By building up a chain of secretaries, however, all working together, various questions and problems may be discussed more or less at length before any definite action is taken. Those with vision can see in such a co-operation between the associations, through the secretaries, the basis for an organization of the National Association of Talking Machine Dealers—something that has been suggested on numerous occasions, and which should prove of genuine benefit to the industry as a whole.

Local associations have shown what can be accomplished in a small way for the betterment of business practices in the trade, and the elimination of various so-called "evils." How much more effective would be the work of a national association along those lines, and the establishment of uniform standards of practice in the retail talking machine trade?

ALL branches of industry have followed the hearings on the new War Revenue Bill before the Ways and Means Committee of the House of Representatives with considerable interest, and the results, which will be formulated in the bill that will be introduced in Congress after a short recess, will have a very vital bearing upon business plans the coming fall and winter.

TO OUR SUBSCRIBERS

If your copy of *The Talking Machine World* does not reach you on publication date, or a few days thereafter, do not assume that it has gone astray. The existing railway congestion has had a serious effect on the handling of mail, particularly second class matter, and brought about unusual delays. Kindly wait a few days longer than usual before writing to us, as the paper will probably arrive safely.

A strong plea for the talking machine industry was made before the committee by Marion Dorian, of the Columbia Co., in which he emphasized the important part that the talking machine is playing in supplying music and entertainment not only for the fighting men in the army and navy, but as a powerful medium for maintaining the courage and optimism of the people at home. He stated that instead of an increase in taxes there really should be a repeal of the present tax on talking machines, because of the essentiality of these instruments in civil and military life.

Judging from the remarks of the committee there is a likelihood of an increase in taxation on talking machines and on musical instruments as a whole, and it behooves every member of the trade to get in touch with his Congressman and present in as strong and as forceful a manner as possible the claims which music has for full consideration, and the necessity for its wider diffusion in these trying days.

The Washington correspondents of the daily papers are evidently unaware of music's important part in the war, for in the reports which they are sending out to the daily papers throughout the country they seem to take pleasure in emphasizing that musical instruments are luxuries, and some of them have the temerity to offer suggestions as to the exact increase of taxation which they consider should be applied in the case of talking machines.

It is really amazing what a fund of misinformation some of our daily papers can supply when it comes to discussing the products of certain industries, notably musical instruments. They seem possessed of the idea that every talking machine and piano man is a millionaire, and that their profits are extraordinary.

It is quite evident that some of our Congressmen have never gone through the school of business experience. Their views are often those of theorists, rather than practical men, when it comes to discussing and analyzing the costs of doing business—at least in certain industries. As a matter of fact profits are far from abnormal to-day, either for the manufacturer or the dealer, and it doesn't require a genius, or even a politician, to discover this. No one who has given real serious study to the conditions to-day in America can fail to properly realize the part music is playing in our civilization, and particularly what a tremendous and inspiring factor it is in these days that are trying men's souls.

**10 East 39th Street
Pearsall Service**

All mail, except bills, should be sent to our new address, 10 East 39th Street, the new home of Pearsall Service. Enlarged quarters and improved efficiency in handling Victor machines and records will give you a Pearsall Service plus. Remember our new number plate 10-E-39.

Silas E. Pearsall Co.

Wholesale Distributors of Victrolas and Records

10 EAST 39th STREET

NEW YORK, N. Y.



A Word to the Wise Is Sufficient!



A day, a week, a month—we simply don't know.

If you can guess how long we will be in a position to accept orders for Brilliantone Steel Needles **AT ANY PRICE** you know more about conditions than we do.

However, *we can and do* promise to fill all orders, *as received*, to the limit of our ability.

You will get a square deal, but whether you get a supply of Brilliantone Needles depends entirely upon how quickly you act upon this well intended suggestion.

BRILLIANTONE STEEL NEEDLE CO. OF AMERICA INCORPORATED

Suite 655-657-659 Marbridge Building, Broadway at 34th Street

B. R. FORSTER, President



NEW YORK CITY

Securing Help, Lost Through the Draft, by Means of Motion Picture Advertising :: By E. A. Dench

The live retailer and manufacturer of musical instruments has now learned to adjust his business to wartime standards. It is folly to be guided by pre-war conditions, for new times demand new methods. The latest bombshell which has fallen in the talking machine man's midst is that he will lose all of his men of draft age. He will, of course, have to replace them with young women and older men, but the help wanted ads are so many that women can pick and choose their jobs. With competition from better paid and shorter hour industries, they are not going to experience an easy time in securing the right kind of help to replace their younger men. The talking machine maker or retailer can take a leaf out of the Government's book. In its urgent need of stenographers and shipyard workers, the Government has advertised for them by slides at the motion picture theatres. The Government's problem is national; the manufacturer and dealer's problem is purely local. So it is essentially a matter of circulation rather than methods. While the Government shows its slides in several thousand motion picture theatres extending across the continent, all you need for your purpose are the local motion picture theatres. Young women and girls are well known for their liberal patronage of the movies, so you will not be able to blame the medium if your slides are ineffective. The right medium is there—100 per cent. efficient—but your slides must reach the same high percentage if you want results. You can sow seeds on a plot of ground and they will come up. You can sow the same seeds on a properly fertilized plot of ground and not only will they come up, but the yield will be several times greater than that of the seeds sown on unfertilized ground. It is the same way with slides at the motion picture theatre, only your fertilizer is more gray matter in the slides.

How many slides the merchant uses, how elaborate the slides are and the number of local theatres in which they are shown depends entirely upon the number of employes he needs. If you are doing a small, yet satisfactory business, in a neighborhood section and can continue with one additional employe, this slide should suit your purpose:

"One of our men has left to join the army. What young woman will fill his place at the same salary?"

Have this announcement placed on a typewritten slide. If the operator employs the stencil process this will do. If neither of these two methods are at his disposal the neat, hand-written slide will serve the same purpose.

However, for an outlay of about a dollar the local photographer will prepare you such a slide in colors, with a soldier in the top left-hand corner beckoning to a young woman in the top right-hand corner.

The jobber, retailer or manufacturer with a

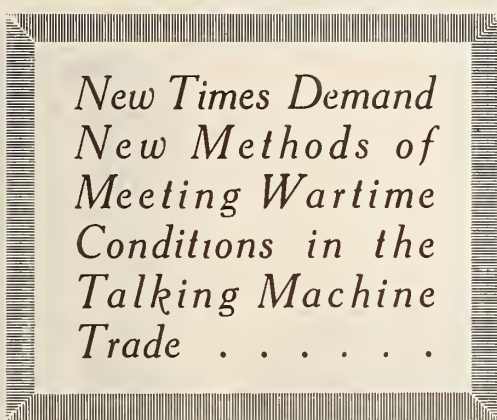

force of from five to twenty men may have to put out a series of slides and screen them in the most desirable local theatres before he obtains his full quota of the right kind of help. However, the same slides can be used from time to time when new people are needed to replace those who are leaving, so the expense is not so great. Here is one such slide which you should show during the first week of your drive:

"Human nature is the basis of the photoplay. Human nature plus merchandising knowledge are the qualifications for a salesman. The war has stripped us clean of young men. We will pay young women the same salaries as the men and teach them the talking machine business."

The foregoing slide may prove perfectly satisfactory so far as applicants are concerned except that there are not enough of them. Assuming that the talking machine dealer, for instance, has tried the slide out in the theatre nearest to his store, I would suggest that he make arrange-

ments with another show in his section to screen the slide. He can repeat the same process with the local theatres until he is fully supplied with competent help.

This plan will save the retailer the expense and trouble of having a number of slides circulating in the local theatres. It will be a simple matter for him to withdraw the slide at a moment's notice without any trouble.

If you have followed my movie advertising articles in the trade papers you will have observed that I do not recommend the talking machine dealer advertising in any theatre but the most suitable one nearest to his store. The only exception to this rule is when the dealer is located in a downtown section and his customers come from all parts of the town. Advertising for clerk help and advertising for more business are two different things. The salesman will not mind a car ride if the job is a good one, but it takes extraordinary inducements to persuade people living in one section to trade in another section. It is for this reason that the retailer in a neighborhood section is perfectly justified in showing his help wanted slides in as many of the local theatres as he sees fit.

If you find that a single copy of a slide will suit your purpose, any local photographer will make you an artistic announcement for about a dollar. If you can use several copies of the same slide, they will cost you about 25 cents apiece. To this you must add the cost of screening the slide, the cost of which will fluctuate according to the seating capacity and location of theatre adopted. If you are already under contract with the theatre it will be a simple matter to temporarily remove your regular advertising slide. The average cost of showing your help wanted slide for a single week will be in the neighborhood of a dollar.

The newspapers are full of want ads, but slide want ads are the exception rather than the rule. If you want your want ad to appear without being sandwiched in between other want ads, use the movies. Even though want ad slides may become as popular as newspaper want ads, the former will continue to be shown separately.

It has well been said that the man or the nation that is slow starting to fight is often slower quitting. Will the Kaiser please take notice.



THE BROOKS Automatic Repeating Phonograph

Plays Any Kind of Record—Any Desired Number of Times and Then Stops Automatically—The Phonograph Sensation of the Age

DEALERS:

You cannot duplicate the value we offer for twice the price. In size and appearance the "Brooks" compares favorably with Instruments retailing for \$300.00 and up.

In tone qualities it is unexcelled by any talking machine on earth! In mechanical equipment and automatic features it is years in advance of its nearest competitor. We have been building talking machines for three years—last year our sales doubled every four months. The BROOKS DEALER has no competition. The machine creates interest and discussion—it is self-advertising. Send for particulars, terms, prices.

BROOKS MANUFACTURING COMPANY
Talking Machine Dept. - SAGINAW, MICH., U. S. A.



View of Controlling Dial

This dial sets, starts and stops the machine. Will play any desired number up to nine or continuous.

Simplest Machine to Operate

Instructions

Set the needle at the inner edge of record cutting and then move pointer to the figure designating the number of times you wish record played.

That is all. You can now forget the machine. When the record has been played as many times as set for, the machine will stop automatically with the tone arm suspended in the air above record.

HEIGHT OF CABINET 50 INCHES
FURNISHED IN OAK OR MAHOGANY
SPRING OR ELECTRIC MOTOR

BORN of a musical family of distinction, the Cecila-
phone has speedily won its way into the stores of
many dealers who appreciate its high merits and
distinctive features and the prestige arising
from the honored name it bears.

The profound knowledge of acous-
tics which has made Bush & Lane
pianos tonally what they are,
and the novel adaptation
of the piano sound
board principle to
the different
form of the
phono-



Style 4
Mahogany, \$235.00
Walnut, \$250.00
Height, 51 inches.
Depth, 25 3/4 inches.
Width, 24 inches



Style 3
Mahogany, \$200.00
Walnut, \$215.00
Height, 51 inches. Depth,
25 3/4 inches. Width,
24 inches



Style 2
Mahogany, \$140.00
Walnut, \$155.00
Height, 46 3/4 inches. Depth, 24
inches. Width, 21 3/4 inches

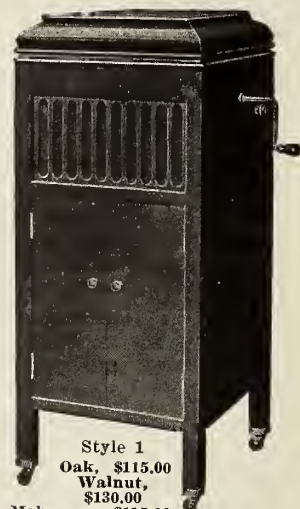

Style 1
Oak, \$115.00
Walnut, \$130.00
Mahogany, \$115.00
Height, 46 1/2 inches. Depth,
21 1/2 inches. Width,
19 1/2 inches

graph
has made
the Cecila-
phone a marvel
in the faithful re-
production of the tones
of the recording artist.

The skill in designing and in
cabinet work which has made Bush
& Lane pianos recognized throughout
the trade for their striking originality and
beauty has produced phonograph cabinets that
are artistically satisfying to the very highest degree.

All Cecilaphones are equipped for playing both lateral and
vertical cut records and have an excellent tone modifier, powerful
double cylinder worm gear motor and balanced spring cover support.

In every respect the Cecilaphone represents the highest
ideals in musical instrument making.

BUSH & LANE PIANO CO.
HOLLAND, MICHIGAN

Kindly send me my illustrated catalog and full particulars
regarding the Cecilaphone.
Name.....
Address.....
City.....
State.....
BUSH & LANE PIANO CO., HOLLAND, MICH.

**Plenty of time yet to Sell Vacation Models
 —Keep right along with the good work.
 —Make July beat January.**



**Columbia Graphophone Co.
 NEW YORK**

FEATURED McCORMACK RECORDS

Wm. Berdy's Artistic Window Display of "Keep the Home Fires Burning"

Wm. Berdy, well-known Victor dealer at 1198 Fulton street, Brooklyn, N. Y., has been devoting a considerable portion of his time the past few months to the preparation of artistic and effective window displays. These displays have



Mr. Berdy's Attractive Victor Window featured Victrolas and Victor records to excellent advantage, and Mr. Berdy attributes a goodly proportion of his sales totals to the impression created by these attractive windows.

The accompanying photograph presents a recent display installed by Mr. Berdy to feature the John McCormack Victor record "Keep the Home Fires Burning." This display attracted considerable attention, and during the time that it was in the window the sales of this popular record increased steadily.

A WINDOW-DRESSING IDEA

Repetition With Variation Claimed to Be a Good Rule to Observe by Merchants

Repetition with variation, in the opinion of a merchant noted for his excellent window arrangements, is a good rule for window displays that get results.

A musical comedy gave him the idea, according to C. C. Le Vade in a little article in System. "You know how they work the members of the company in groups," he says. "Two or three come on the stage in one arrangement, they go off, another group appears, they exit, and a new combination of both groups appears.

"I apply the same principle in my window dressing. After any setting that has been on display for a time is changed, I select a few of the articles to use again in the next display. Thus the articles repeated gain emphasis from being shown in a variety of combinations."

The chief troubles in this country this year are going to be troubles of transportation. And right here is where the auto truck steps in and fills the bill.

ENJOY ANNUAL OUTING IN TORONTO

Employees of R. S. Williams & Sons Co. Participate in Very Pleasant Affair

TORONTO, ONT., July 2.—The employees of the R. S. Williams & Sons Co., Ltd., this city, held their tenth annual outing at Queenston Heights recently, which proved one of the most successful affairs in the history of the company. Williams & Sons Co. are Edison jobbers in this section, and a number of their dealers took advantage of the invitation to join with their employees in the enjoyment of the outing.

The party journeyed from Toronto to the grove on a chartered steamer, and during the trip there were a number of games and contests to keep all hands interested. Upon arrival at the grounds there were more games of all sorts, including bowling contests, racing and a football game. Members of the staff provided an excellent musical program during the boat ride, and there was dancing at the grove. A pleasing patriotic touch was given to the outing by the fact that invitations had been extended to a number of convalescent soldiers to join the party, and quite a number accepted. As was apparent in the photograph, so kindly sent The World, the soldiers were given the position of honor in the front.

Every dealer can tell you the exact amount of his gross sales for the month, but can he tell you the exact cost of getting his business?

PATHE PUBLICITY CAMPAIGN

Interesting Series of Advertisements Inaugurated in the Saturday Evening Post—Specific Records Being Featured by the Company

The Pathé Frères Phonograph Co., Brooklyn, N. Y., used in the June 15 issue of the Saturday Evening Post a striking quarter-page advertisement which inaugurated a new idea in Pathé national advertising. According to the plans of the company similar advertisements will appear every week in the Saturday Evening Post for some time to come, and this publicity is well calculated to impress the millions of readers of this publication with the distinctive merits of Pathé products and the musical value of Pathé records.

In the June 15 advertisement two records were mentioned by name and number, and it is the intention of the Pathé advertising department to continue featuring specific records so that the dealers may receive the benefits of this direct advertising. Emphasis was placed upon the fact that "You can play Pathé records on any make of machine," and this phrase will also be used in the entire series of advertisements. A portrait of Muratore, the world-famous tenor who sings exclusively for the Pathé library, gave a personal touch to this advertisement which enhanced its value considerably.

Hope, when not harnessed to hustle, is really a handicap.

**THIS ALBUM MADE US FAMOUS
 by selling it. Why don't you try?**

Buy Your Albums Direct From the Manufacturer

43-51 W. Fourth St. **THE BOSTON BOOK CO., Inc.** Chicago Office: 1470 So. Michigan Ave.
 New York, N. Y. **The only exclusive Record Album Factory in the world.**



Patented



“B & H” Fibre Needles

The only Fibre Needles licensed for sale in the
United States

The B & H Fibre needle was *born of necessity*
and has made *good*.

It is the needle of *Tone—of Quality*.

The needle that *cannot* injure the record and—
The ONLY needle that has brought about the
sale of thousands of Talking Machines and
of hundreds of thousands of Records.

This means money to you—
Think it over

B & H FIBRE MFG. CO.

33-35 W. Kinzie Street - - - - - Chicago

Standard Price Legislation Necessary to Protect Buying Public, Says Joseph E. Davies

Edmond A. Whittier, secretary-treasurer of the American Fair Trade League, recently gave out for publication a letter of approval of the Stephens Honest Advertising bill from Joseph E. Davies, of Wisconsin, former Commissioner of Corporations and first chairman of the Federal Trade Commission, of which body he has been a member until he recently resigned to become candidate for United States Senator. The communication, which was addressed to Mr. Whittier, is of interest to members of the talking machine industry, and follows:

"During my association with the Government—as Commissioner of Corporations and as a member of the Federal Trade Commission—I have been deeply interested in the problems of price stabilization and of predatory price cutting. In the course of investigations of these subjects which I have directed I endeavored to keep an unprejudiced mind, and could not, pending official action, with propriety indicate my personal attitude regarding these problems, the solution of which must be based on a careful consideration of the rights of producer, distributor and consuming public. Now that my responsibilities in that regard have ceased, however, I am very glad indeed, in response to your request of May 25, to state to you frankly my views.

"Since the Miles decision by the Supreme Court it has always been my judgment that the courts would hold all attempts at resale price control as a violation of existing law. My opinion in that respect has been verified by the recent decisions. They were inevitable so long as our legislative policy was predicated on unrestricted competition for the reason that any schedule of standard resale prices, established by the individual producer of an article, must necessarily confine competition between jobbers and between retailers of the article to service, quality and other factors than price.

"But my experience has shown me that under existing law, as thus laid down by the courts, practices have become prevalent which constitute a menace to legitimate business interests and are likewise a serious injury to the consuming public.

"I am impressed with the necessity of doing justice and giving proper governmental protection to the manufacturer of branded goods who produces standard goods of fine quality, behind which he places his name and reputation, and for which he has created a valuable good will by great and conscientious effort. I believe the public interest will be served by so doing.

The practice of some dealers who use such goods as sensational cut-price bait for the sale of anonymous goods is, in my opinion, unfair and reprehensible in the last degree. Likewise the practice of some dealers in advertising such goods for continued periods of time at prices below their costs is, in my opinion, not justified. Such competition is not fair, and is not the competition which it should be the policy of the law to encourage, but is, in fact, an indefensible misuse of the reputation of another. It is a wrongful misappropriation of the value created by the producer to further the dealer's personal and unrelated interest.

"As the American Fair Trade League has so many times pointed out, the country storekeeper, the city specialty merchant and the neighborhood store often find it difficult to exist if staple products are used by the powerful concerns cutting prices in such a way as to create the impression that these smaller competitors are overcharging the consumer on everything else in their stocks. These small units of distribution lose not only the sale on these products, but the confidence of the public. Realizing these conditions there can be no doubt in

the mind of any fair-minded man but that these evils ought to be corrected, and these abuses prevented by law, but in the application of the remedy it is of paramount importance that the public interest should be safeguarded in every possible way.

"I well understand that advocates of the one-price-to-all principle honestly contend that, in the absence of monopoly or combination, which are specifically forbidden any privileges under the Stephens bill, competition between producers

cause of doubt I believe it would be the disposition of many people who are disinterested to oppose legislation that permitted a producer to determine the resale price of his article with no other restriction than that which competition imposes.

"For the reasons stated, I believe the Stephens bill should be amended so as to repose in a governmental agency, such as the Federal Trade Commission, the power, upon its own initiative or upon complaint, to review and adjust equitably the terms of the resale contract. With such a provision included the Stephens bill would, in my judgment, secure to producers, distributors and the public all the benefits and economies of price stabilization on standard merchandise and at the same time afford every possible protection of the public interests."

The Stephens Bill, When Amended, Will Ensure Price Stabilization on Standard Merchandise

of similar articles will assure constant improvement in quality and constant lowering of price to consumer. It is argued that all trade history proves this, and the automobile and other articles are cited as evidence. Yet we must, I think, recognize and satisfy the doubt which has remained in many minds on this point. I feel sure that the members of your league would favor any restriction or amendment to the Stephens bill which may meet every sincere, unselfish objection and facilitate its passage. Be-

A CHANGE IN WASHINGTON

Van Wickle Piano Co. Succeeds F. G. Smith Piano Co.—Handles Columbia and Victor

WASHINGTON, D. C., July 3.—After forty years spent with the F. G. Smith Piano Co., of this city, as manager, and later as vice-president, W. P. Van Wickle recently organized the W. P. Van Wickle Piano Co., Inc., of which he is president, and took over the F. G. Smith Piano Co. business. The new company will continue at the old address and will handle the same lines of pianos as formerly, as well as the Victor and Columbia lines of talking machines and records. The machine department of the company is under the management of John F. Abendschein, assisted by C. W. Carter and William J. Wright. A very large and constantly expanding business has been developed.

Delpheon
the
Incomparable

A tone that is ineffably exquisite—not phonographic



Delpheon \$75 Model

THE DELPHEON COMPANY
BAY CITY :: :: MICHIGAN
OR WRITE TO DISTRIBUTORS

Columbia

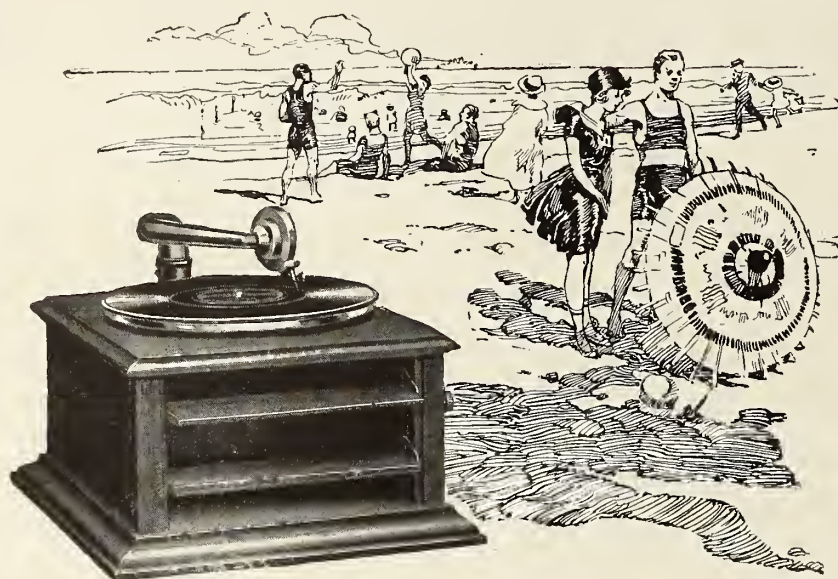

Portable Grafonolas for Vacationists—

Why should folks go without their Grafonolas while they're away from home? Vacation-time is play-time—and what jollier companion could there be, for amusement and recreation, than one of these traveling-model Grafonolas?

For dancing, for afternoon parties, for evenings about the camp-fire, for chasing away the blues on rainy days—vacation days simply *multiply* the need of cheerful music.

They're light and sturdy and easy to get about, these compact Portable Models. People take to them the instant they see them.

You should plan to see every vacationist in your town.

Columbia Graphophone Company
New York

Grafonolas

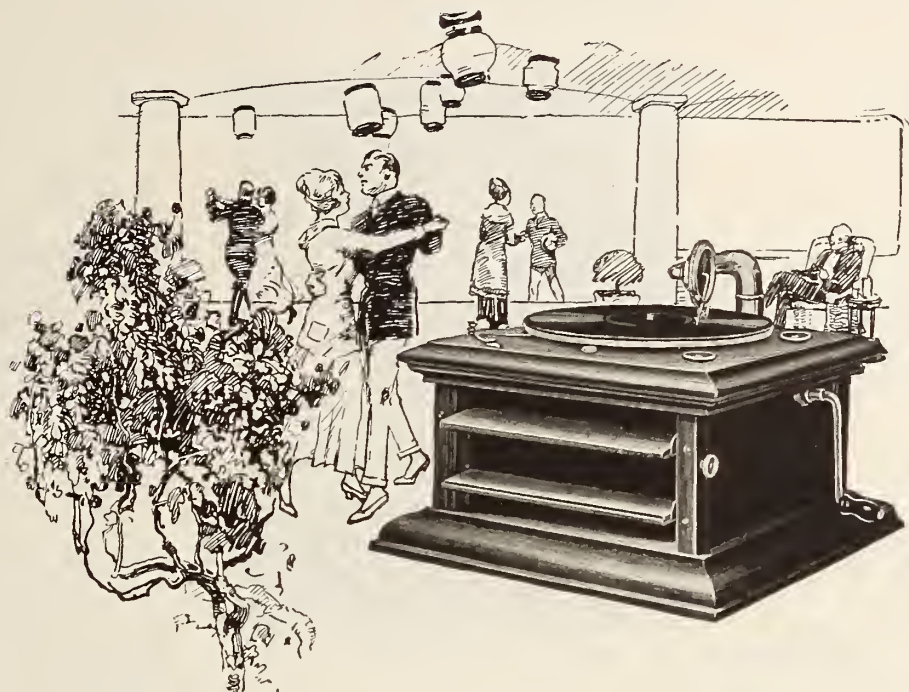

A Big New Field for Dealers

Every now and then someone comes along with a new selling idea for moving goods—and how those goods *do move!*

That's the net of this "Vacations with Music" idea. It is a big thing for the live, aggressive Columbia Dealer who will push sales on the Portable Models this summer.

It is such a sound selling idea!

Of course, people want music on vacations—that's the time of all times for all the fun it is possible to crowd into 24 hours.

But you've got to tell them about it—and keep on telling them. Better let us help you—with some of the snappy, catchy display material along these lines. It's ready for you.

Columbia Graphophone Company, New York



Sell Foreign Language Records

Small investment needed—quick turnover—good profit. Widely advertised. Write for details.

International Record Department
102 West 38th Street, New York

HOW TO TREAT YOUR CUSTOMERS

Some Timely Pointers for Those Members of the Sales Force Who Are Sorely Perplexed at Times When Handling Their Customers

It costs your store money every time someone walks out without making a purchase. If the goods are right then this tragedy is due to the fact that the prospective customers were not handled correctly. One of the big department stores in New York tries to solve this problem by giving to every employe a chart on which are listed various kinds of customers. These customers are separated into five groups, each requiring different treatment by the salespeople. The following is the chart:

GROUP 1	
<i>The Customers</i>	<i>How to Treat Them</i>
Tired and cross	Patience
Unreasonable	Good temper
Fussy and nervous	Quiet manner
Interrupting	Assurance
Ignorant	Assurance
Excitable	Assurance
Foreigners	Assurance
GROUP 2	
Patronizing	Dignity
Aggressive	Confidence in your ability
Inquisitive	Knowledge
Skeptical	Common sense
Talkative	Common sense
Insulting	Common sense
GROUP 3	
Cautious	Belief in your goods
Critical	Knowledge of value of goods
Indifferent	Care in presenting goods
Bargain Hunter	Convincing manner
Silent	Convincing manner
Penurious	Convincing manner
GROUP 4	
Timid	Sympathy
Sensitive	Gentleness
Dependent	Helpfulness
Absent-minded	Suggestion
Deaf	An effort to think for them
Old ladies	An effort to think for them
Undecided	An effort to think for them
Children	Kindness always
GROUP 5	
Decided	Gratitude
Pleasant	Gratitude
Intelligent	Gratitude
Common Sense	Gratitude

When a sale is lost, or when a customer does not seem thoroughly pleased, refer to this chart and put the customer under one of the five classifications. Then ask yourself whether you handled that customer as one of the salespeople in that New York store would have done, were he or she in your place. If you read over this chart several times you will soon familiarize yourself with it, says the Emerson Spotlight. Then it will be a simple matter to know how to treat a customer in the right way.

Why not patriotic concerts in your warerooms these days, Mr. Dealer? Why not try them?

H. B. RAY WITH PATHE FRERES CO.

Appointed Advertising Manager of This Prominent Institution—Well Known in the Trade

The Pathé Frères Phonograph Co., Brooklyn, N. Y., announced recently the appointment of H. B. Ray as advertising manager of the company, who assumed his new duties on July 1, succeeding J. H. McShane, who has resigned.

H. B. Ray is one of the best-known members of the talking machine industry, and has been associated with the trade for many years. He was previously advertising manager of the Columbia Graphophone Co., and is recognized as an authority on all matters pertaining to the publicity end of the talking machine industry.

It is interesting to note that Mr. Ray's acquisition to the Pathé forces completes a trium-



Herbert B. Ray

virate of well-known talking machine men who formerly held important executive posts in this field and who are now associated with the Pathé Frères Co., these three men being George W. Lyle, assistant to President Widmann, of the Pathé Frères Phonograph Co.; George P. Metzger, of the Hanff-Metzger Advertising Agency, who is in charge of the company's publicity, and H. B. Ray, the new advertising manager. All of these veterans of the industry were formerly working together, and the fact that they have again joined forces insures maximum co-operation and service for Pathé jobbers and dealers.

ELIMINATE LIST PRICE ON RECORDS

Victor Co. Announces New Plan to Avoid Confusion in the Event That Record List Prices Are Raised in Future—An Important Move

The Victor Talking Machine Co. announces that in view of the increase in the price of certain records, and the uncertainty of the future as it will govern record prices, the company has decided to discontinue printing the list price on record labels, and thus avoid any possible chance of embarrassment on the part of dealers in collecting any future increases from customers. The company's announcement reads in part: "With the cost of material, the cost of labor and the cost of everything else going sky-high, it must long ago have been evident to anyone that some time there would surely be an increase in the prices of Victor products, and we presume the announcement to that effect made during the month of May was no great surprise to anyone concerned.

"A difficulty which must always occur in such cases was that it was impossible to clean the slate overnight. In the case of record catalogs, for instance, there was nothing to do but 'tip in' printed slips announcing the increase of our catalog list prices from 75 cents to 85 cents and from \$1.25 to \$1.35, on ten and twelve-inch double-face records respectively. Quantities of advertising literature and quantities of records already distributed bore and still bear the old prices, but since the whole world has been educated to raised prices ever since August, 1914, no serious embarrassment is occasioned when it becomes necessary to charge more for an article than the price formerly known.

"Because no one can foresee exactly what conditions may have to be met while the country is at war, we shall discontinue printing our list price on the record labels. This will avoid all future embarrassments and facilitate the changing of prices under any circumstances without haranguing with the customer on account of lists printed upon records."

RECORDS BY AMPARITO FARRAR

Columbia Co. Releases First Recordings of This Artist and Metropolitan Opera Orchestra

The Columbia Graphophone Co. has announced the addition to its recording library of the Metropolitan Opera Orchestra and Miss Amparito Farrar, a well-known concert soprano. Records by this orchestra and by Miss Farrar are announced in the new July list which went on sale June 20.

The Metropolitan Opera Orchestra is one of the best-known musical organizations in the country, and the Columbia record of Faust's famous Ballet Music will undoubtedly meet with a ready Miss Amparito Farrar sale to music lovers in all parts of the country.

Miss Farrar is a native of Oregon, and studied in Paris, London and Berlin. She has been very successful on the concert stage, and made her debut in the Columbia library with a record, featuring "Sweet and Low" and "Mighty Lak a Rose." Both of these additions to the Columbia library are exclusive Columbia artists.



WORTH REMEMBERING

"Whatever your wages may be in dollars per week, per day, per hour, remember you are working for two—your employer and yourself. Be as fair to him as you expect him to be to you, think, anticipate, plan, suggest, and the salary question will be solved."

Ward's Khaki Moving Covers



PROTECT YOUR MACHINES FROM ALL KINDS OF WEATHER

and will enable you to deliver them free from dust, scratches, bruises and all other finish destroyers

Our covers are faced with Standard Khaki, lined with a heavy grade flannel, interlined with an exceptionally good grade of heavy cotton or felt, diagonally and closely quilted, and manufactured according to the usual superior "WARD New London" quality.

- Grade "D", medium size, \$6.00
- Grade "D", large size, \$6.50
- Grade "K", medium size, \$8.00
- Grade "K", large size, \$9.00

Carrying Straps: No. 1 \$1.00; No. 2 \$2.00; No. 3 \$3.50

ORDER SAMPLE COVER ON APPROVAL

With Name of Machine silk embroidered on any Cover; extra... 30c.
With Dealer's Name and Address, first Cover; extra... \$1.15
Same on additional Covers, each extra... 60c.

Write for booklet

THE C. E. WARD CO.

(Well-known Lodge Regalia House)

101 William St., New London, Ohio

Also Manufacturers of Rubberized Covers and Dust Covers for the Wareroom

Grade "D" Cover with No. 3 Straps.



DEALERS



Have **you** written us
asking about the

OKEH RECORDS

If not, send us your name and address and we will put you on our monthly mailing list. Get familiar with the latest product backed by the House of

Otto Heineman Phonograph Supply Co., Inc.

25 West 45th Street
New York City

**Heineman
Meisselbach**

Motors

Tone Arms

Sound Boxes

Dean

Steel Needles

**Quality
Counts**

Sign this and mail it to us today

Otto Heineman Phonograph Supply Co., Inc.
25 West 45th Street
New York City

Gentlemen:

Place us on your monthly mailing list

Name _____

Street _____

City _____

State _____



"THE GRAFONOLA IN THE SCHOOL"

Interesting Volume, Copiously Illustrated, Issued Under Above Title, Which Should Make a Wide Appeal When Properly Distributed

The educational department of the Columbia Graphophone Co., New York, has just issued an impressive and profusely illustrated publication entitled "The Grafonola in the School," which contains valuable information regarding the use of the Columbia Grafonola from an educational standpoint.

The first page is entitled "Music Is a Necessity," and presents the following phrase by Wm. E. Gladstone: "Those who think music ranks among the trifles of existence are in gross error, because from the beginning of the world down to the present time it has been one of the most forcible instruments of training both for arousing and governing the mind of man." The illustration on the page shows a song leader at one of the cantonments rehearsing the U. S. Army boys during their regular song period.

Two pages are devoted to the use of the Grafonola by children in the home and in the kindergarten, these pages being appropriately illustrated. "The Grafonola in Story-Telling" features the Thornton Burgess Bed-Time story records, which have attained wide success. Columbia patriotic records are presented under the heading of "The First Step in Preparedness for a Singing Army," showing the pledge of allegiance by the school children to the flag and to the republic for which it stands; the Grafonola furnishing the music for the brisk march that is played after the salute.

Other interesting pages in this publication feature the "Grafonola in the Grades"; "The Columbia Penmanship Course"; "Co-ordinating Music With Other Subjects"; "The Columbia in the Flag Drill"; "The Columbia in Folk Dances"; "The Grafonola in the High School"; "The Grafonola in Music Appreciation"; "The Columbia Grafonola in Modern Languages"; "The Columbia in Commercial Studies"; "The Grafonola in Social Dancing"; "The Grafonola in Interpretative Dancing"; "The Columbia in Rural School Music"; "Folk Dancing in the Rural School"; "The Columbia in Model Training Classes"; "The Grafonola in Community Singing"; "The Columbia Operatic Records" and "The Columbia in Music History."

Each one of these important subjects is accompanied by a brief description of the particular use of the Grafonola in the respective field featured. Appropriate illustrations together with a short list of records at the bottom of each page make this volume valuable to dealers interested in the possibilities afforded for the development of Columbia business in the educational world.

ANOTHER DOEHLER ADDITION

Ground Broken for Erection of Ten-Story Building in Brooklyn—Made Necessary by Growth of Trade With This Progressive Concern

Ground has just been broken for the new addition to the Doehler Die-Casting Co.'s Brooklyn factory on Court and Huntington streets. This addition will cover 150 feet on Court street and 200 feet on Huntington street, and will be ten stories high; actually doubling the present capacity of the plant.

Construction will be of steel and concrete throughout, to conform to the general character of their present massive structures, the last addition to which was completed and has only been occupied since September 1.

Newly perfected types of automatic die-casting machinery are now in process of construction, ready to be installed in the new building, which is to be ready for occupancy before the summer is over.

While the greater portion of the company's activities are devoted to Government and war work the requirements of the regular trade which in the main is now also for Government war consumption, are receiving the usual attention.

REVOLVING WINDOW DISPLAY

Has Been Prepared by Pathé Frères Phonograph Co. for Utilization by Dealers

The advertising department of the Pathé Frères Phonograph Co. has just advised dealers that it has prepared a revolving window display



Featuring the Pathé Trade-Mark

which features the world-famous Pathé trade-mark, the red rooster. This display works by electricity, and as indicated by the accompanying illustration, combines attractiveness with practicability, as it not only attracts the attention of passers-by, but also impresses upon them the pleasing appearance of the Pathéphone model 25.

Don't neglect getting in touch with the public through advertising this summer.

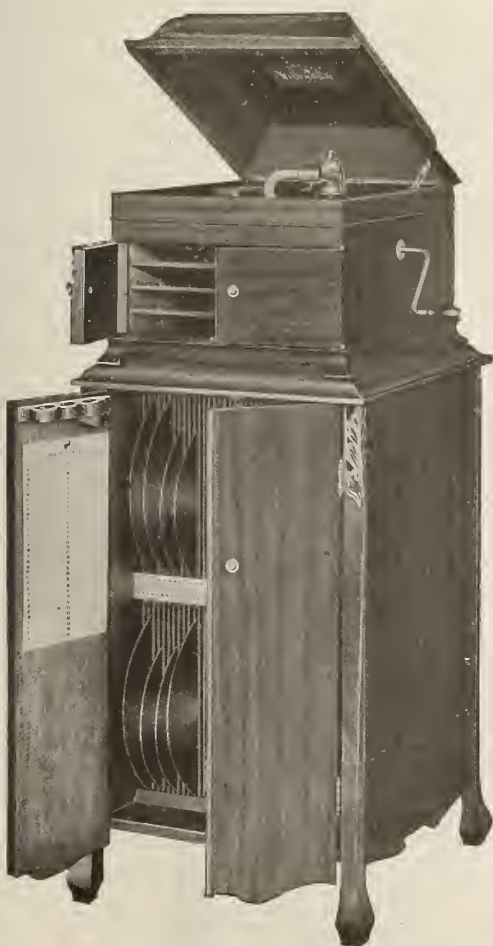

No. 19. Cabinet (DOUBLE DOOR FRONT)

Made especially to hold the Victor-Victrola, No. IXA

Get the Benefit

of the big business doing right now on both talking machines and records by handling

SALTER Felt Lined Cabinets

These two styles are not only remarkable outfit sellers but are equally attractive to people who have cabinet machines but need more record storage capacity.

SEND FOR CATALOGS

Showing many other attractive styles.

We also make a beautiful line of sheet music and music roll cabinets.

SALTER MFG. CO.

337-49 N. Oakley Boulevard

CHICAGO, ILL.



No. 111. Cabinet (Opened) For Columbia \$50.00 Machine 33 1/2 inches high. Top, 23 x 19 1/2 inches

We Offer An Unusual Proposition To Dealers

It doesn't matter what make of phonograph you are now handling, you owe it to yourself to investigate what we have to offer you.

We have developed a great talking machine co-operative plan—one that enables the aggressive dealer to make big money on quality talking machines.

We are staking our money and our reputation on this proposition to establish successful talking machine dealers in every community.

In this advertisement we illustrate Model No. 3—our big seller. It is stately in design, wonderful in tone, and is sold under our guaranteed service. It sells for \$125.00, and unquestionably represents greater value than was ever offered at this price.

This machine is one of the big factors in our co-operative selling plan.

Two additional models—Model No. 6 at \$90.00, and Model No. 5 at \$65.00, give the MANDEL dealer three popular priced machines, all of which embody high quality coupled with big value to the consumer.

What we offer you, Mr. Dealer, is liberal terms, liberal discounts, big profits, and our guarantee of absolute satisfaction to every ultimate purchaser of a MANDEL Phonograph.

Act quickly. Write for our complete proposition. We are closing up territory at record speed.

Mandel Manufacturing Company

General Offices:
501-511 So. Laflin Street
CHICAGO, ILLINOIS

New York Display Rooms:
41 Union Square
NEW YORK CITY, N. Y.

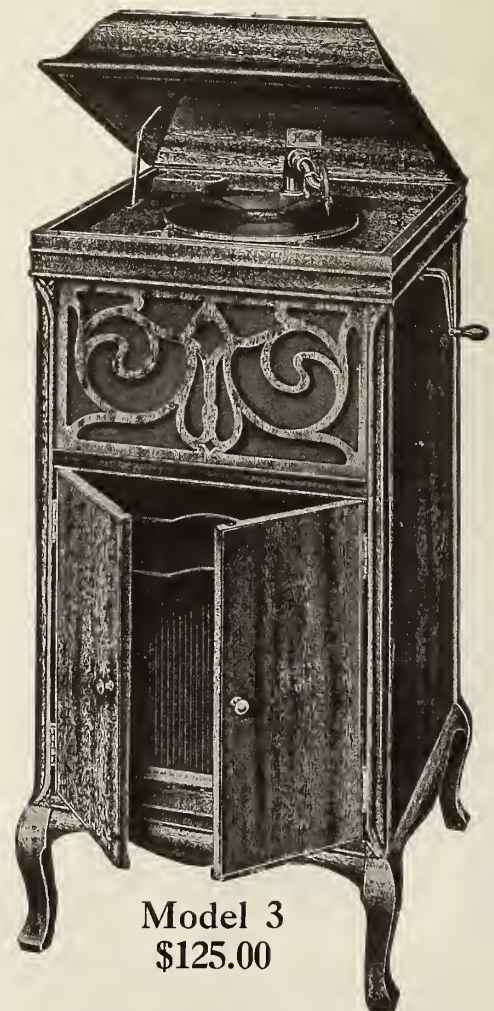

Model 3
\$125.00

Artistic Window Displays That Arouse Public Interest In Talking Machines and Records

The talking machine industry has always been thoroughly awake to the importance of making retail window displays highly attractive to passersby. This month instead of outlining sugges-

of imitation foliage and makes a pleasing contrast to the treeless and grassless section of the usual city downtown district. A handsome picture of one of the Columbia artists lends a human touch to the effect.

display of this kind means records in the tongues of the different nationalities shown are available in this store, and it seems highly probable that when the costumes portrayed are true to life in every detail (as they are in this case) that the window should prove of decided interest to the foreign element in any community. Incidentally this window is arranged in such a way as to link up perfectly with the national advertising of foreign records done by the Columbia Co.

The third illustration portrays a window designed by C. C. Baker, of Columbus, O. It is particularly worthy of notice be-

All four of the window displays herewith re-

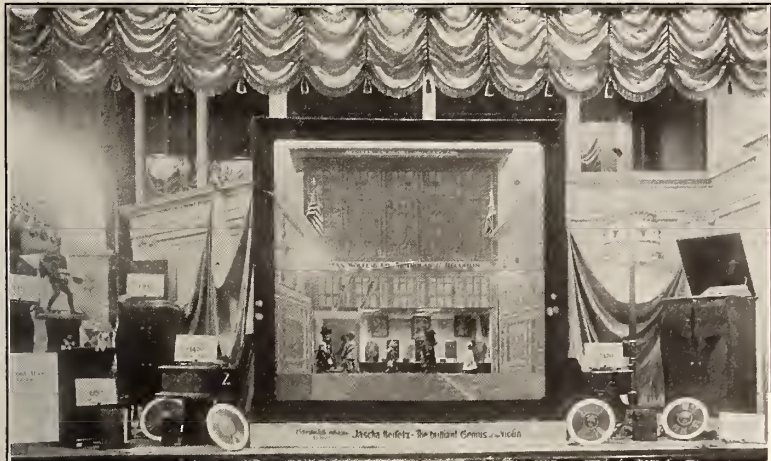

Lipman, Wolfe & Co. Display, Portland, Ore.

tions for window decoration we are reproducing several excellent displays in order that dealers throughout the country may get a concrete idea of what their fellow merchants are doing to attract public interest in the talking machine and talking machine records. These illustrations may be stimulative to those who overlook

cause it carries out the classical atmosphere that should be always present when period models are displayed. Naturally these higher-priced



Window Display of Ashdown Hardware Co., Ltd., Winnipeg

models appeal to people of artistic temperament or who aspire to it; and in either case the period model in a window

produced exemplify the value of "getting away" from the all too prevalent practice of placing two or three different models of machines in the window and pasting a couple of record posters on the glass pane. It is hard to conceive of a time or a place where the simple display of machines

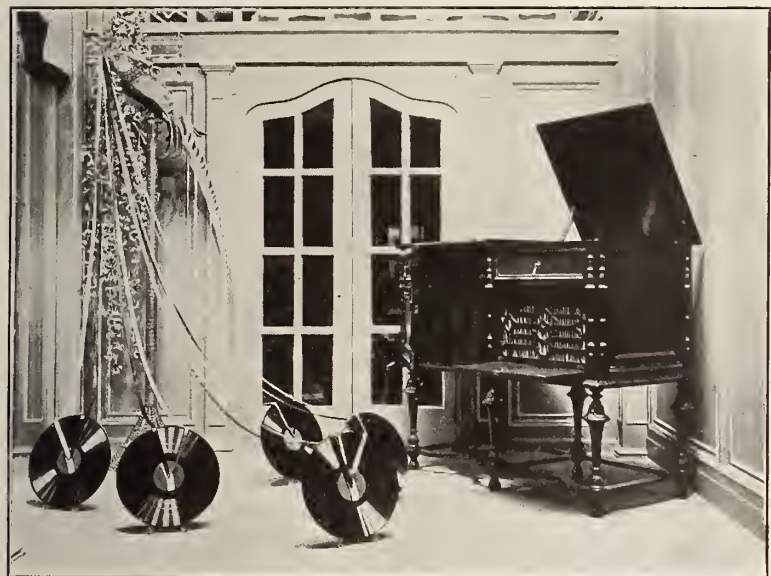

Unusually Artistic Window Prepared by C. C. Baker, Columbus, O.

the value of the window as a sales and publicity medium.

The first illustration is that of a window used by Lipman, Wolfe & Co., of Portland, Ore. It is really more than a window display, as it includes a feature that is in nature more of an invention. The center of window is a relief reproduction of the exterior of the Lipman, Wolfe store. Well-dressed mechanical dolls are made to pass in one entrance to the miniature store and come out of another, each doll carrying Victrola records. In line with the central display, the rest of the window is devoted to various types of Victrolas and the latest records. The window in its entirety is a very clever piece of work and attracted extraordinary attention because of the continually moving figures that arrest the eyes of everyone going by the window. This device is the invention of H. A. Willard.

The second illustration shows a window of the J. H. Ashdown Hardware Co., of Winnipeg, Canada, in which good use has been made of artistic and brightly colored placards, each one concentrated on one point, such as the individual qualities of the Grafonola or the particular merit of a certain record. The background is

display is shown to best effect when placed in an environment of the plus ultra sort. The window shown here is certainly in accord with the graceful lines of the period model and merits high praise.

The fourth picture shows a window of the Home Furniture Co. in Braddock. The entire floor space in the window is given up to flat models of men and women clad in the national costume of many foreign nations. Of course a

in a window is warranted because window space is very expensive and therefore should be used only in a way that will be productive of the best results.



Display of the Home Furniture Co., Braddock, Pa.

Talking Machine Hardware

We manufacture hardware for all styles of cabinets

Lid Supports
Needle Cups
Needle Rests

Door Catches
Sliding Casters
Continuous Hinges

Sockets
Tone Rods
Knobs, etc.

BEST QUALITY

LOWEST PRICES

WEBER-KNAPP COMPANY

Jamestown, N. Y.



Early American
Console No. 1

The Widdicomb
A Finished Product



Queen Anne
Console No. 3

**NOT ALMOST AS
GOOD BUT BETTER**

—in so many ways that on MERIT
this unusual line cannot help but outsell
—and stay sold—

BECAUSE—of its exceptional clear-
ness in the reproduction of any record
—without extra parts—

BECAUSE—For the money—there has
never been offered such real value in
design, construction, finish, motor and
equipment—

BECAUSE—THE WIDDICOMB
dealer has so little motor trouble—
BROKEN SPRINGS BEING UN-
KNOWN—

BECAUSE—Our electric motor is
different and absolutely reliable and
runs perfectly on any current—the only
motor which does—

BECAUSE—The all wood horn—Bal-
anced cover support—Record files—
Automatic stop—Jewel points—are all
of the very best. The tone control can
be set at any volume or volume can be
controlled from a distance.

BECAUSE—The factory behind THE
WIDDICOMB has a reputation for
reliability since 1865.



Queen Anne
No. 6



Adam
No. 5

**Quantities of Widdicombs
Are Ready**

Send for literature **NOW** and protect
yourself at **PRESENT** prices.

ELEVEN MODELS

Table Types \$150 to \$225 Upright Cases \$100 to \$250

Phonograph Division

Widdicomb Furniture Co.

GRAND RAPIDS, MICH.



Adam Console
No. 2



Chippendale

TALKING MACHINE MEN ATTEND ROTARY CONVENTION

Jobbers and Dealers From Various Sections of Country Visit Kansas City for Meeting and Are Entertained by Local Men—Dealers Making Strong Bids for Business—News of the Month

KANSAS CITY, Mo., July 5.—Most of the talking machine dealers have been busy entertaining the guests which the international convention of Rotary Clubs brought to Kansas City. Not only a great many men engaged in the talking machine trade visited the retail shops, but the concert rooms were filled with Rotarian music lovers from all vocations. During the Rotary Week, which commenced June 24, the Paulist Choir presented two evening entertainments at the Auditorium Theatre. The Columbia Grafo-nola Shop is anticipating a big business in the Paulist records for this reason. "We have already begun to experience a growing demand for the story records of Thornton Burgess," said D. M. Guthrie, retail sales manager, "and since his talks to children in the parks during Rotary Week the sales are showing a marked increase. Conditions in all lines are very good with us."

The Starr Piano Co. is featuring its trench and camp outfits in talking machines and records. An unusual and attractive window display draws the attention of the passers-by to the added pleasure which one of these outfits would bring to soldier or camper. The background and part of the floor is covered with mossy rocks while a miniature lake occupies the foreground. The machine with records is encased in an olive drab case.

A. A. Trostler, of the Victrola department of the Schmelzer Arms Co., finds the conditions of a month ago unrelieved, the inadequate supply of stock being the only drawback to a record-breaking season. As it is, June of this year will make a very favorable showing. Miss Leona Carter has been added to the sales force of the department.

Miss Marie Henel, of the Victrola department of the Schmelzer Arms Co., was married Saturday, June 22, at Nevada, Mo., to Willard Bayne, connected with the base hospital at Jefferson Barracks, St. Louis.

The Schmelzer Arms Co. erected a booth on the sidewalk in front of the store for the sale of War Savings Stamps, known as "The Torch of Liberty," and used during the official W. S. S. day, June 28.

Ralph E. Wood, formerly of Chicago, and for the past eight months in the Victrola department of the Jones Store Co., has gone to Camp Funston, Kan., where he will enter the service.

"Patriotic records continue favorites with the public, judging from sales," said Mrs. Nellie Williams, manager of the Victrola department of the Jones Store Co. "Since Christmas we have received a reasonable supply of machines and records, but they have not lasted a reasonable length of time." A. R. Willey, who makes use of his Spanish to further sales among the Mexican and foreign element has worked up a very successful trade. The people love music and are very easy to wait on, according to Mrs. Williams, for they know what they want and indicate it by "Yes" or "No" without a lengthy conversation. The only trouble is that they have to be held back or one customer will take the whole stock of Mexican and Spanish records. As an example, Mrs. Williams cited a case where she had just received about fifteen records out of a much larger order, and a customer was selecting a number. All of a sudden he glanced up and seeing another Mexican coming, grabbed the fifteen in his arms crying, "I taka all dees."

The Edison Retail Shop has been having an unusually good month. B. P. Woodward, sales manager, has recently purchased a new Marmon "Six," though but just recovered from a serious automobile accident.

H. C. Stanton, vice-president of the R. S. Williams & Sons Co., Ltd., of Toronto, Canada, was in Kansas City attending the Rotary convention. Mr. Stanton read a paper on "Music During the Great War and After," which attracted

much favorable comment from all music trade men who attended the Musical Round Table of Rotarians held at the Salon Mora. With reference to talking machine conditions in Canada Mr. Stanton, who is an Edison jobber, said: "We have recovered from the war depression entirely and more recently from the serious restraining influence of our boys coming back from the front. Our determination to win the war, however, does not leave us unmindful of the home needs and the education of the children, in which, of course, music plays such an important part. Business in our line can be said generally to be very satisfactory in volume. The fall outlook has everything in its favor."

B. J. Pierce, manager of the Victrola department of the J. W. Jenkins' Sons Music Co., has left on a brief business trip to Tulsa, Okla.

Glen Ellison, Scotch baritone, will give a number of tone test recitals among the Edison dealers in Kansas City and vicinity during July and August.

The H. W. Lee Music Co., of Enid, Okla., recently performed a patriotic service worthy of comment. Mr. Lee and his entire force closed the store for a week or ten days and went into the wheat harvest fields to help.

W. L. Eshelman, of the Eshelman Music Co., St. Joseph, Mo., was in town attending the Rotary convention. Mr. Eshelman is president of the St. Joseph Rotary Club.

George E. Mickel, a Victor jobber of Omaha, Neb., and his wife, also Lester Burchfield, of Sanger Bros., Dallas, Tex., were guests of A. A. Trostler during the week of the international convention of Rotary Clubs.

Harry Beach, assistant sales manager of the Victor Talking Machine Co., Camden, N. J., was a visitor to this city last week.

M. M. Blackman, manager of the wholesale department of the Edison Phonograph Co., has just returned from an Eastern trip lasting about three weeks. Mr. Blackman, in company with W. M. Hinde and C. T. Cunningham, attended

the Edison convention in New York, June 6 and 7. Mr. Blackman afterwards visited Atlantic City and Washington, D. C., stopping in Chicago for several days on his return.

Harold Masters, of the order and service department of the Edison wholesale, has left for Fort Leavenworth to enlist in the Signal Corps.

VICTROLA LEADS TO COURT DISPUTE

City Marshal Forces Way Into Apartment to Seize Machine and Is Summoned to Court on Assault Charge—Judge Upholds Him

The right of a City Marshal, armed with a writ of seizure, to break into a home in order to seize a Victrola upon which instalments had lapsed, came up for decision before Magistrate Simpson in the Harlem Court in New York City recently, and the City Marshal was upheld in his action.

On June 4 Samuel A. Sherman, a Victrola dealer of 2138 Third avenue, brought suit against a man named Prakesch to recover a Victrola which he had purchased on the instalment plan, and upon which payments had lapsed. The machine was in the home of Mrs. Emily Sigmund, 29 East 177th street, and she was therefore made a co-defendant in the suit.

The action was undefended and judgment was obtained by Sherman. A writ of seizure was issued and placed in the hands of City Marshal Kemp, who, accompanied by a clerk, went to seize the machine. Mrs. Sigmund refused to admit the City Marshal, and he called a policeman who upheld him in his demand for admittance. The result was that the Marshal was compelled to break in the door, and was then attacked by Mrs. Sigmund, who was finally restrained by the policeman. The machine was then seized and removed.

Mrs. Sigmund subsequently secured summonses for Kemp, his clerk and the policeman, charging that they had insulted her and showing bruises as proof of her charge. The court refused to entertain the complaint, maintaining that the City Marshal, when armed with the proper writ, was empowered to enter the premises in the fulfilment of his duties.

A Message to Phonograph Dealers

People shop around nowadays before buying their Phonograph.

The Phonograph buyer to-day is demanding better musical value than ever before.

You have to *show* them that *yours* has the best musical quality.

Can you meet this demand?

The **BLISS REPRODUCER** with its treated silk diaphragm is both musically and mechanically correct.

By carrying **BLISS REPRODUCERS** in stock you can make many sales that would otherwise go to your competitor.

This is the reason why so many dealers carry **BLISS REPRODUCERS**.

Money is not made on lost sales.

We are featuring other Phonograph Specialties—among them the Disk-Lite, a lighting attachment for any phonograph.

The Phono-Lite, an automatic lighting attachment for the New Edison.

Edison Diamond Points. Edison and Pathe Sapphire Points.

WRITE US FOR DEALERS' PRICES

WILSON LAIRD PHONOGRAPH CO., Inc.

Factors and Distributors of the **BLISS REPRODUCER**

29 West 34th Street

NEW YORK CITY

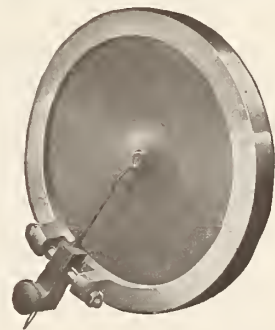

Are You Neglecting Any Prospects?

STATION in life or worldly wealth has no bearing on a person's appreciation of the beauties of good music.

A dealer in a small Southern town is selling Amberolas far more rapidly than his jobber can supply him because he believes that *every* family wants music and is willing, if necessary, to make sacrifices to get it.

He is in a territory that has been thoroughly canvassed by talking machine men, but his experience shows that people who must make a genuine sacrifice for musical enjoyment want the best or nothing. He proves daily that the

New Edison Diamond Amberola

will bring to the home the best music at a price within the reach of everybody.

Edison dealers, don't permit outward appearances to deprive hundreds of families of the advantage of good music.



THOMAS A. EDISON, Inc.

ORANGE, N. J.

Headliners!

Nora Bayes—Al Jolson—Harry Fox—Farber Sisters—Van and Schenck. A new Columbia Record by every one of these top-notchers, this month.

**Columbia Graphophone Co.
NEW YORK**



DEVELOPING TRADE IN SUMMER

Some Pertinent Suggestions by J. I. Carroll Showing How Dealers Should Take Advantage of Trade Opportunities in Hot Weather

J. I. Carroll, assistant sales manager of the Emerson Phonograph Co., recently sent out to the members of his sales staff the following interesting bulletin which gives his ideas regarding spring and summer business, and which contains many logical and sales-stimulating suggestions:

"There is a tendency among some dealers, as the summer season approaches, to either reduce their normal purchase of records, or, in some few cases, to discontinue purchasing new releases entirely until along toward September.

"Why does the dealer follow this demoralizing, thoroughly unnecessary, and decidedly unwise policy? He'll tell you people don't buy records in the warm weather, whereas, as a matter of fact, the trouble lies almost entirely with himself. He lets up in his effort, allows his stock to run down, and, in consequence, not having the latest numbers, and having breaks in his stock of prior numbers, his trade becomes convinced of the absence of service on up-to-the-minute songs and dances, falls away, and his record department suffers. Such a dealer cannot escape his responsibility. He frequently places the blame everywhere, but it rightfully belongs—directly with himself.

"Fortunately, the percentage of such dealers is small, almost invariably they are the small ones who lack enthusiasm, initiative, imagination and progressive ideas; the kind that don't know how to take advantage—because of too limited vision—of splendid opportunity to improve, develop and render more profitable their Emerson departments.

"The spring and summer months are logical times for the sale of popular records—the Emerson kind. People are brighter, freer, happier and gayer than at any other time of the year. What is more natural than music—snappy, lively, pretty music—to meet the demand of such light-hearted temperament?

"Comparatively few folks have summer homes; only a small portion—some young folks—leave on vacations—and short ones, too—in consequence, the home remains intact, and entertainment must be furnished, and the phonograph supplies it.

"Where people have summer homes, the phonograph is sure to be found. Again records are necessary. Urge the dealer to go after the summer record business harder than ever. Show him how. Let him resort to novel advertising methods.

The enterprising dealer who uses sound judgment

in this matter will sell plenty of records, hold his trade, and enter the fall season with a well-ordered department, equipped to increase his sales, double his profit and surround himself with a satisfied and appreciative stream of customers. Some dealers have told us they sell more records during the spring and summer

months than at any other season of the year.

"The fellow who is so narrow, short-sighted and unprogressive as to follow the opposite course will drive away, utterly undo any good he may have accomplished, and find his department at the approach of the fall season badly, if not irreparably, shattered."

MANY WAR WORKERS KEEP NEWARK TRADE PROSPEROUS

Employees of Shipyards and Munition Factories Generous Purchasers of Talking Machines and Records—New Edison Selected for Madison, N. J., High School—General News

NEWARK, N. J., July 6.—The talking machine trade of Newark closed exceptionally good business for the first half of the year. June proved especially good and, but for the shortage of records which appears prevalent in this territory, the dealers have no complaint.

Newark was never more prosperous than at present, wages being high in all industries, especially so in the shipyards and the plants doing Government work. This labor element, which several months ago was not so permanent, owing to men constantly changing their jobs, has now settled down. The number of cash sales are large and the instalment business is being done with large first payments and upon good monthly terms.

One thing that has made record sales good is the fact that the Prudential Life Insurance Co. has a number of quartets on the street who attract the passers-by so that salesmen and saleswomen can dispose of War Savings Stamps. The most popular songs with this group are "Keep the Home Fires Burning" and "There's a Long, Long Trail." These same songs were sung in chorus by all the children in a recent parade in which they appeared. John McCormack sang the latter number in one of his concerts here recently as well as "God Be With Our Boys To-night," another record having large sales.

The talking machine department of the Otto Wissner warerooms is feeling a good demand for both machines and records. W. H. Paullin,

manager of the department, is pleased with the outlook. The Columbia and Sonora are handled.

The Chalmers Co., who have a number of stores in this territory, report a good volume of business closed for the first half of the year. The demand for popular records with this company has been very heavy. However, the company having five stores must carry quite large stocks so they were able to meet most of the demands. The house of Chalmers handles the Victor line exclusively.

The Edison Shop, 861 Broad street, is finding business good and the cash transactions as well as the size of the payments have been very gratifying. Le Baron M. Huntington, vice-president and manager of Phonographs, Ltd., who conduct the Edison Shop, is quite pleased over a recent sale he made to the high school of Madison, N. J., where the New Edison was selected unanimously after a series of demonstrations had been given.

H. J. Smith, the well-known jewel specialist, who operates a laboratory at 833 Broad street, has just returned after several weeks spent in Canada at a record laboratory.

Leonard J. Rheinhardt, manager of Jacob Doll & Sons, states the sales of Pathé machines during the month of June were good. Most of the sales have been marked by the size of the cash payments.

Dealers are feverishly placing their orders for further stocks of machines as the local agents feel the fall will see a distinct shortage.



AUTOMATIC STOPS

The simplest and most efficient Automatic Stop on the market. They give excellent service, are easily installed and are absolutely guaranteed.

Send 50 cents for Sample Stop

KIRKMAN ENGINEERING CORPORATION, 237 Lafayette St., New York

COTTON FLOCKS

.. FOR ..

Record Manufacturing

THE PECKHAM MFG. CO., 238 South Street, NEWARK, N. J.

THE TRADE IN BOSTON AND NEW ENGLAND

JOHN H. WILSON, MANAGER, 324 WASHINGTON STREET, BOSTON, MASS.

BOSTON, MASS., July 3.—The dealers' monthly meeting at the Columbia Graphophone Co.'s Federal street headquarters was held the latter part of June and, as usual, was an unqualified success. Manager Fred E. Mann presided. It was expected that Charles W. Harrison, one of the artists making records for the company, would be present, but he was suffering from a cold; so in his place Henry Burr came over from New York. Mr. Burr sang eight or ten songs and was accompanied by Fred Phillips, of the Leo Feist Co. The August monthly records were tried out and the dealers were delighted with them. O. F. Binns, in charge of the record department for the company, came over from New York also and gave the company an illuminating talk which was full of good advice for the dealers. As the meeting was held toward the end of the month not quite as many dealers were present as on the last occasion.

Active Times With L. M. Pierce Co.

Manager Hotschke, of the L. M. Pierce Co., Springfield and Holyoke, was a Boston visitor a short time ago and he made an excellent report of business conditions at the two talking machine stores, which he operates. The company has lately added the Pathé line, and Mr. Hotschke's visit was largely to confer with Wholesale Manager Ainslie, and to make a selection of Pathé machines. These goods have just been shipped from the Hallet & Davis establishment. Mr. Berwick is in charge of the Holyoke store which, like the Springfield store, is well arranged to meet the demands of customers.

Outing of Oliver Ditson Co. Force

The Oliver Ditson Co., which handles the Victor line, gave an outing to its employes Saturday, June 29, which consisted of a trip down Boston harbor and among the islands. Henry Winkelman, the manager of the Victor department, and all his staff were present, and among the youthful guests who made many friends was the young son, clad in nautical attire, of Otto A. Piesendel, Manager Winkelman's right-hand man.

Manager Winkelman makes a most encouraging report of his Victor business which for the month of June went way ahead of this time a year ago. And business would be even larger were the goods to be had from the factory. Mr. Winkelman is spending the summer at a large

farm up at Acton, owned by one of his relatives, and when business is over he nightly turns his attention to farming with most encouraging results.

Pleased With Results of Convention

Manager Silliman, of the Pardee-Ellenberger Co., has been quite enthusiastic since his return from New York over the success of the Edison convention, where everybody appears to have had a good time. He speaks with especial enthusiasm of the success achieved by Mr. Edison in so disposing of the new velvet re-creations at the convention as to completely equip one of the transports with a full Edison outfit. Mr. Silliman, in speaking of business, said the other day that the proof of what his department is doing is seen in the fact that June had proved to be way ahead of the same month of a year ago, and he paid a special tribute to his field men for the hard work they had put in to help achieve so excellent a result. F. S. Boyd, of the traveling staff, will be the first to get away on a vacation and he will probably spend his time somewhere in Maine.

Visited Columbia Plant at Bridgeport

Arthur Collins, of the repair service department of the Columbia Co., has been spending a few days at Bridgeport, where he has been devoting his time to studying the new motor and the new automatic stop with which the new Columbia models are to be equipped. It is a commendable plan of the company to invite all the repair men at various times to the factory in that Connecticut city for the purpose of familiarizing themselves with these new devices which Manager Fred E. Mann says are destined to play so important a part in furthering the popularity of the Columbia product.

Edwin M. Morgan Joins Forces

Edwin M. Morgan is one of the newcomers to join Manager Mann's Columbia staff in this city. Mr. Morgan comes to the company with a high reputation in business circles and he has many friends in Boston where he has been in business off and on for a number of years. He will have charge of Suffolk and Norfolk counties, a territory lately in charge of W. A. Hine, who has resigned.

Warren Batchelder in New Post

Warren Batchelder, manager of the Victor department for the A. M. Hume Music Co., has severed his connection with this house, having

accepted a position with the Community Motion Picture Bureau, which works under the auspices of the Y. M. C. A. and which is furnishing entertainment for the men at the front and in the cantonments. Mr. Batchelder will be located at Newport News, Va., for the present. The local trade will miss Mr. Batchelder, as he has been a favorite hereabouts. A. M. Hume, head of the house, is away on a vacation.

Interested in Radio Work

Elton Taft, Jr., son of the head of the Eastern Talking Machine Co., has been away from the house for the past two weeks, for, having become interested in radio work, he is studying hard preparatory to attaching himself to the service. Wholesale Manager Billy Fitzgerald is planning to go to Camp "Tis Ours" in Maine some time in August, where he has been for several summers.

Camping at Long Pond, Me.

Richard Nelson, Southern New England representative of the Sonora, motored down to Harrison, Me., a few days ago accompanied by his wife, where they are the guests of Mr. Nelson's father at the latter's camp on the shores of Long Pond, near Sebago.

Takes on the Pathé Line

The North Shore Phonograph Co., at Gloucester, is one of the latest houses to take on the Pathé line. This place has been visited by a number of the summer residents of that aristocratic summer residential section, all of them anxious to study the merits of this machine.

New Emerson Dealers

The Emerson Co. is making great progress with its new nine-inch record in the territory supervised by Manager Oscar W. Ray. Among the new dealers to handle this record are the Chamberlain Co., of New Haven, Conn.; Ather-ton Furniture Co., at Lewiston, Me.; Henry W. Upham, at Malden; J. L. Charlifoux Co., at Lowell; Great Eastern Furniture Co., at New Bedford; Otis Skinner, at Bangor, Me., and F. F. Foss, at Portland, Me.

John Alsen Heard From

George Lincoln Parker returned to Boston well satisfied with the success of the Edison convention at which he was accorded distinguished honors. He says the new velvet re-creations are coming along very well and there has been quite a number of the owners of Edison outfits calling at his warerooms to hear these

Victor Dealers In New England Territory

can rest assured that EASTERN VICTOR SERVICE has their interests individually at heart, particularly with respect to the securing of Victor stock. Our aim is to help the Victor dealer make the most of the existing conditions.

EASTERN TALKING MACHINE CO.

177 TREMONT STREET

BOSTON, MASS.

THE TRADE IN BOSTON AND NEW ENGLAND—(Continued from page 26)

new records. Mr. Parker's office lately received a postcard picture from John Alsen, the erst-while phonograph manager for this house, who is now with the 101st Engineers in France, showing himself in uniform. Alsen writes that he has gained considerably in weight since being abroad.

New Columbia Dealers

Bates & Holesworth, furniture dealers at Framingham, have added a Columbia department to their establishment and they are planning to have a grand opening on the Fourth of July, or the day following. The house is located near the railroad station and is very convenient both to business and the residential section. Mr. Holesworth recently was graduated from the Wentworth Institute, where he prepared for service, and he is now in the South at one of the cantonments.

Another new Columbia dealer is Carbone Brothers, four of them, who have opened an establishment at 1731 Washington street. Three of the brothers will hustle on the outside for business and the store will be in charge of the fourth brother, Prince Napoleon, whose name alone ought to draw business. Prince Napoleon probably bears the distinction of being the smallest Columbia dealer in the country.

Miss Clark in Charge at White's

As anticipated last month Fred L. MacNeil has found himself in service, and supplanting him as manager of the talking machine department at the R. H. White Co. is Miss Minerva Clark, who has lately been with the Aeolian Co. Earlier in her career in the business Miss Clark was a demonstrator for the Columbia people.

Francis T. White, manager of the Edison and Victor department of the C. C. Harvey Co., is planning to take his vacation somewhere in New Hampshire the first week in August. A new accession to his staff is Miss Marion Collyer.

Booking Big Hallet & Davis Business

Wholesale Manager R. O. Ainslie, of the Pathé phonograph and record line, has been meeting with marked success since he associated himself with the Hallet & Davis Co. in his present capacity. Lately he made a trip among the Vermont dealers, and he was especially enthusiastic over the prospects in Rutland, where the Tuttle Co. has opened a new place especially for the sale of talking machine outfits, the Pathé and Columbia lines being featured. The store is known as the United Talking Machine Company, and M. O. Tyrell is in charge. Manager Ainslie has arranged for supplying the store with an initial invoice of forty-four Pathé phonographs and a large and complete line of

Lansing Khaki Moving Covers

PROTECT VARNISH IN ALL WEATHERS

and enable you to deliver your phonograph free of blemishes of all kinds.

These covers are made of Government Khaki, interlined with heavy felt or cotton, fleece-lined, quilted and properly manufactured. Perfect protection in all weather.



No. 3 Carrying Strap Shown in Cut

Made in Two Grades

Write for Prices and Descriptive Catalogue

Use the Lansing Khaki Moving Cover and your delivery troubles will be over.

E. H. LANSING
611 Washington St., BOSTON

SAN FRANCISCO OFFICE, Room 530 CHRONICLE BLDG.
WALTER S. GRAY, Manager

records. The interior of the store is admirably arranged to handle business, says Manager Ainslie, and in a series of open compartments down one side of the store and on a raised platform the various types of machines are conspicuously displayed. This establishment is one of the finest of its kind in Rutland.

Looks for Big Summer Business

Manager F. H. Walter, of the Brunswick-Balke-Collender Co., says he is looking for big business following the end of the summer season, and for this there are ample indications at this time, as many of the company's dealers are reporting with good-sized orders. He has just taken on a new member of his staff, Miss Florence Clemence, who formerly had been with two other talking machine houses in the city.

Victor Activity With Steinert & Sons Co.

Victor business with the M. Steinert & Sons Co. is keeping up very well, thanks in large degree to the thoughtful, conscientious work put into the business by Robert L. Steinert, who is head of the Arch street store. Mr. Steinert, as

well as his elder brother, Russell S. Steinert, was an usher at the funeral of A. Shuman, Boston's big and philanthropic merchant the latter part of June; and their father, Alexander Steinert, was named as one of the executors and trustees of Mr. Shuman's will. Mr. Steinert's wife was a daughter of Mr. Shuman.

Much Interest in New Vocalion Record

The new record announcements of the Aeolian-Vocalion went out this week and there has been much interest manifested in the new discs. Manager Hibshman has been spending the last three week-ends over in New York, where his family are making a visit at New Rochelle. Amos E. Russell, a member of Manager Hibshman's staff, reports marked activity in every branch of the department. It may be remarked that at a recent luncheon of the Pilgrim Publicity Association Mr. Russell was the singer, using as a special number "Under the Stars and Stripes." Messrs. Hull and Alfring, from the New York offices of the Aeolian-Vocalion forces spent a few days in Boston lately.

— Oldest and Largest
Manufacturers of Talking
Machine Needles in the
World—There are several reasons

W. H. BAGSHAW CO., Lowell, Mass.

HELPS FOR THE VICTOR DEALER

Electrotypes for Booklet Covers Prepared by Victor Co. to Enable Dealers to Call Public Attention to Less Known Records

In order to permit the individual dealer to call the attention of the public to some of the less known records on his shelves, thereby offsetting in some manner the existing shortage of popular records of the day, the Victor Talking Machine Co. has prepared a most elaborate series of electrotypes for folder covers. The electrotypes are designed for two-color printing and are of the rich poster type so popular at the present time and likewise as effective.

There are also provided electrotypes of decorative borders for center pages of folders, within the confines of which are to be set the list of records featured and details regarding them.

This new Victor service enables the dealer to have printed his own individual folder in which he can feature only the records actually in stock. The electrotypes of both covers and inside borders are furnished at a price that will serve materially to reduce printing expense.

TO MANUFACTURE PHONOGRAPHS

The Colonial Phonograph Co., Sheboygan, Wis., has been incorporated with capital stock of \$10,000 to manufacture and deal in phonographs. The incorporators of the new company are L. J. Jenkins, J. G. Olsen and Hugo Kaems.

Sidney C. Eastman, referee in bankruptcy, on July 12 directed the payment of the first dividend to the creditors of the Republic Phonograph Co., of Illinois, bankrupt.

WHERE OKEH RECORDS ARE MADE

Spacious and Well-Equipped Plant Occupied in Springfield, Mass., Which Is Under the Capable Direction of Messrs. Griffin and Kraemer

The accompanying photograph presents the latest additions to the group of factories controlled by the Otto Heineman Phonograph Supply Co., Inc. This factory, which is located at Springfield, Mass., is the home of the "OkeH" records, manufactured by the Otto Heineman



Latest Addition to Plants Controlled by Otto Heineman Phono. Supply Co. Co., and is also the headquarters for the International Insulating Corp., a recently formed cor-

Send for Descriptive Circular

Curry DEMONSTRATION BOOTHS AND RECORD CASES
MADE TO ORDER

"SOUND PROOF"

FRANK B. CURRY
19 Wareham St. Boston, Mass.

poration, which is one of the Heineman subsidiaries.

Under the able direction of Thos. E. Griffin and Chas. Kraemer, this factory at Springfield, Mass.,

is being equipped in a thoroughly efficient and up-to-date manner, machinery of the most approved type having been installed for the production of "OkeH" records. Judging from the enthusiastic reception accorded these records, it is safe to say that this factory will be obliged to work to capacity to turn out sufficient records to meet the demand, but the facilities that are now being provided each department of this plant will insure prompt service to the Heineman "OkeH"

record clientele, and enable this record to attain country-wide popularity.

SELLING DELPHEONS IN ATLANTA

Some Interesting News From Mr. Sunderland Which Tells of Activity in the South

BAY CITY, MICH., July 6.—R. W. Gresser, sales manager of the Delpheon Co., of this city, received this week an interesting letter from D. G. Sunderland, of the Delpheon Shop, Atlanta, Ga., which contains statements that are rather unusual and exceptionally gratifying for this time of the year. He states that he has been closing a phenomenal business in his retail store at 117-119 Peachtree Arcade, notwithstanding the fact that competition in that city is keen and active.

He mentions that during the first twenty days of June he sold sixty-two Delpheon table machines, and thirty-six cabinet machines, and a part of his letter reads as follows: "Our business is jumping by leaps and bounds, and we are doing more business in our little store than I had ever hoped to do. Personal solicitation has been the making of us, and we have four salesmen that do nothing but go from one door to another. They are making a direct appeal to the people, and that, I have always maintained, is the only way to sell goods."

WM. PHILLIPS AN INCORPORATOR

Wm. Phillips, president of the Mutual Talking Machine Co., New York, is one of the incorporators of the Central Mica Mining Co., which has been incorporated to act as direct representative of mica mines in Central America. One of the other incorporators of the company is Harry Breidenbach, a prominent downtown broker. The offices of the company will be located at 145 West Forty-fifth street, New York, and it is planned to carry in stock a large supply of mica suitable for the manufacture of diaphragms.

Digest one motion before you tackle another. The mind resents gluttony, and rebels against overloads. Don't cram the brain with new problems if there are a lot of old ones left unsolved.

The Victor Talking Machine Co. has declared a quarterly dividend of 1 3/4 per cent. on preferred, and 5 per cent. on common stock, payable July 15, to stockholders of record June 12.

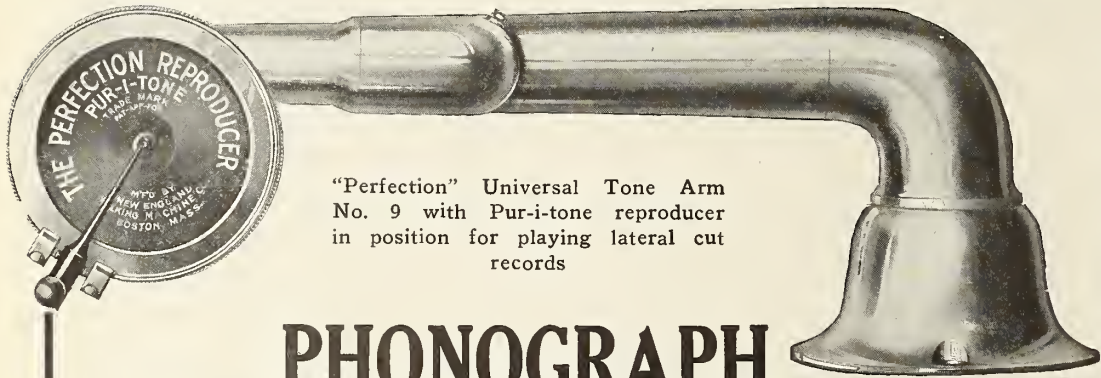

"Perfection" Universal Tone Arm No. 9 with Pur-i-tone reproducer in position for playing lateral cut records

PHONOGRAPH MANUFACTURERS

Our new PERFECTION Universal tone arms models 7, 8, 9, and 10 are now ready for shipment. Our new PUR-I-TONE reproducers models 6 and 7 that are attachable to these tone arms are ready for shipment in any quantity.

Our new Universal arms will play all makes of lateral and Hill and Dale records by a simple turn of the reproducer. We guarantee that the PUR-I-TONE reproducers will not only reproduce all records with perfect amplification of sound, but we also guarantee a perfect reproduction of high pitched soprano voices on lateral cut records, and with extra fine clarity of sound. We have 50,000 sets of arms in 4 different forms ready for quick shipment, also 4 different models of reproducers that are attachable to these arms. PERFECTION Universal tone arms models Nos. 9 and 10 can be supplied with or without ball-bearing base, models Nos. 7 and 8 without ball-bearing base. These arms and reproducers are guaranteed to be the very finest that are manufactured for use on all kinds of phonographs. Write to us for quantity prices, advertising matter, etc.

Mr. Edison Disc Dealer

It is up to you to prevail upon your jobber to handle PERFECTION arms and reproducers, to play records other than the Edison on machines that you sell. Our new FLEXI-TONE reproducer is the most perfect phonograph reproducer ever built, and you want them in your stock. Write your jobber and tell him that you must have PERFECTION arms and reproducers.

NEW ENGLAND TALKING MACHINE CO.

Manufacturers of PERFECTION Phonograph Accessories

16-18 Beach Street

BOSTON, MASS.



UNICO

Designs and Construction
Patented

SYSTEM

THE SALES BUILDER

Unico Demonstrating Rooms
Excel from Every
Standpoint

- DESIGN Six standard styles
Special period styles
- CONSTRUCTION Patented, Interlocking
Portable Units
Sound Insulated
- FINISH All standard Oak,
Mahogany and Enamels
- EFFICIENCY Increased sales at lower
cost per sale
- ECONOMY Moderate first cost
Always an Asset
Adaptable any location
- DELIVERY Prompt shipments from
stock ready for im-
mediate use



Unico Racks and Counters
Maximum Capacity
Minimum Space

- DESIGN Patented to correspond
with Unico Rooms
- CONSTRUCTION Sectional Units adapta-
ble to any space
- FINISH All standard Oak, Ma-
hogany and Enamels
- EFFICIENCY All records always
available instantly
- ECONOMY Moderate Equipment
Cost
Lower Operating Cost
- DELIVERY Prompt shipments from
stock in all finishes

Install a
Complete Unico Department



- DEMONSTRATING ROOMS
- RECORD RACKS
- RECORD COUNTERS
- CEILING DECORATIONS
- ARCH TREATMENTS

The Unico System has
Increased Sales and Profits
for almost 1000 dealers



Send to-day dimensions of your available space. Plans and
estimates for a complete department will reach you promptly

THE UNIT CONSTRUCTION COMPANY

RAYBURN CLARK SMITH, President

Fifty-eighth Street and Grays Avenue, PHILADELPHIA, U. S. A.

MARKETING THE CECILAPHONE

Bush & Lane Co. Make Extensive Plans to Develop the Phonograph Department of Their Vast Business—Producing Attractive Models

HOLLAND, MICH., July 6.—The Bush & Lane Piano Co., who have been making an excellent talking machine for something over a year past, are now ready to market on a more extensive scale and are coming before the trade generally with their product. The machine has been a success following along the custom of everything produced by the Bush & Lane Co. It has heretofore been known simply as the Bush & Lane phonograph, but as a result of the desire expressed by many of the dealers for a distinctive symbolic talking machine name, they have adopted that of the Cecilaphone. The selection is a particularly happy one for two reasons. In the first place, it is associated with that of the patron saint of music, Saint Cecilia, and it also hitches up with the quality reputation of the famous Bush & Lane Cecilian player-piano.

The Cecilaphone was only brought into existence after long and thorough experimental work by Walter Lane, the president and general superintendent of the Bush & Lane Co., who is known the country over as a skilled piano builder and a designer of piano cases of unusual beauty.

Several models of the Cecilaphone, illustrations of which are presented in their advertisement elsewhere in this issue, are exceptionally artistic and symmetrical. The cabinet work, the character of the veneers and the finish all commend themselves at once to connoisseurs. The Cecilaphone has a special horn construction which, born of Mr. Lane's experience in sound board and piano construction, contributes in no small degree to the really superb tone of the Cecilaphone.

Dealers wishing to secure the agency for the machine, which will appeal to the very highest class of trade in their locality and which carries with it proof of its unusual value, would do well to investigate the Cecilaphone and the claims made for it.

ROBERT T. IANNELL ARRIVES

C. J. Iannell, manager of the talking machine department of Bloomingdale Brothers, New York, has been bursting the buttons off his vest with great regularity during the past couple of weeks, due to the fact that he is the proud father of a brand new son, born June 25. The new arrival will bear the cognomen, Robert T. Iannell. The youngster is already making a noise in the world.

STRIKING NEW VICTOR POSTER

Attention Called to Victor Patriotic Records Through Medium of Genuine Work of Art

One of the most effective Victor record posters for window and showroom display that have been issued by the Victor Talking Machine Co. for some time past is that sent out a few days ago and bearing only the words: "Patriotic Victor Records. Come in and Hear Them." The poster is most striking as a timely work of art, showing in the foreground representa-

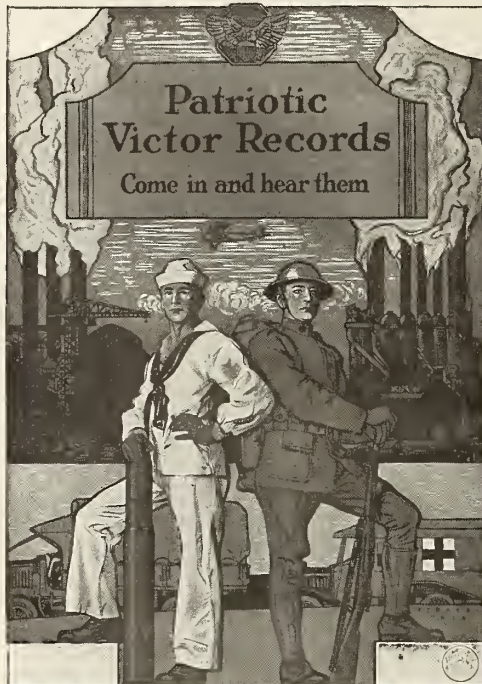

Patriotic Poster Featuring Victor Records
tives of the army and the navy, and in the distance the shipyard and the steel mill busy in war work. In the middle distance there appear a transport truck and a Red Cross ambulance, while overhead there flies an airplane. The accompanying illustration gives some slight idea of the artistic character of the poster, which is suitable not only for displays during the Fourth of July period, but at any time during the war. In issuing the poster the company emphasizes the fact that talking machine dealers have never had a greater opportunity to encourage the use of patriotic music in celebrating Independence Day.

The Columbia Graphophone Mfg. Co. has declared its regular quarterly dividend of 1 3/4 per cent. on common stock, payable July 1, to stockholders of record June 12.

INCREASE IN RECORD PRICES

Columbia Co. Announce List Prices of Their Records Will Go Up on August 1

The general sales department of the Columbia Graphophone Co. announced recently that effective on August 1, the list price of all Columbia records now listed at 75 cents will be increased to 85 cents. In a letter to the trade the Columbia Co. stated that the increase in the list price of the 75-cent record was occasioned by the tremendous advances in the cost of labor and the greatly increased freight rates on raw materials and record shipments.

In deciding to advance the list price of the 75-cent records the Columbia Co. carefully considered every detail of the industrial situation, with the idea of holding this increase in abeyance until absolutely necessary. The steady advance, however, in the freight rates and the increase in the cost of labor made the new prices absolutely imperative, but in order that Columbia dealers might be fully apprised of this decision and be guided accordingly in the conduct of their business, the announcement was made six weeks in advance of the date decided upon to increase prices.

BARS MAIL ORDER ADVERTISING

Everybody's Magazine Announces Such Advertising Will Be Refused After September

The latest magazine to come out against the publication of mail order advertising, with a view of protecting the interests of the local merchants throughout the country is Everybody's Magazine, which announces that all contracts for mail order advertising will be refused after the September issue. This new move follows the acquirement of Everybody's Magazine by the Butterick Publishing Co., New York. The Butterick house, it will be remembered, barred all mail order advertising from its three women's magazines, headed by the Delineator, over a year ago.

THREE FUNDAMENTAL PRINCIPLES

There are three fundamental principles in advertising; namely, be honest, be sensible, be industrious. Be honest, because every advertiser should remember that advertising doesn't create value, it merely tells of it. The value has to be in the article itself. Be sensible because the majority of people who read copy are endowed with good common sense. Be industrious because you have to keep everlastingly at it to succeed. People soon forget unless we keep advertising.—Hugh Chalmers.

Dayton Motors

Sold all over the world
Used in all high class
Talking Machines

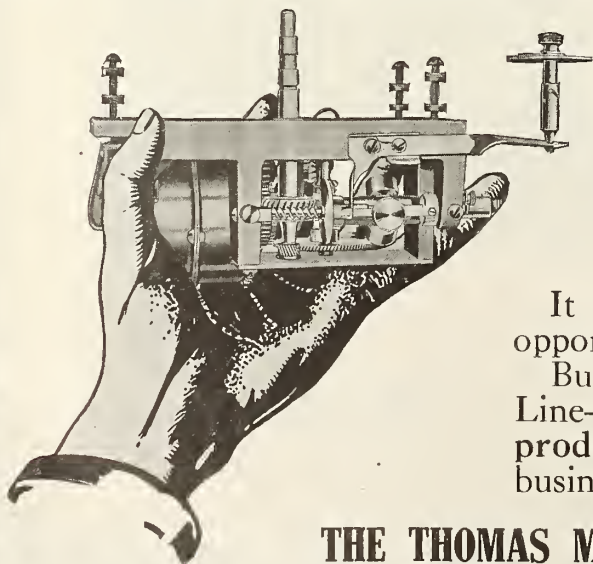

They have won wonderful and enduring popularity and embody the silent running, reliable and durable features that delight the customer and satisfy the builder. The Dayton Motor is considered by manufacturers and users as being

The Best Built Motor in the World

It has made good in Thousands of machines. Give us an opportunity to prove it.

Build satisfaction into your products by using our Quality Line—Dayton Motors, Dayton Tone Arms, Dayton Reproducers. All styles and sizes. They will bring you more business and satisfy your customers. Write for full particulars.

THE THOMAS MFG. CO., 322 Bolt Street, DAYTON, OHIO, U. S. A.

NEW PATHEPHONE ART MODELS

Two Very Artistic Designs Along Old English Gothic Lines Being Introduced to the Trade

The Pathé Frères Phonograph Co., Brooklyn, N. Y., has just announced the addition to its line of two art model Pathéphones, designed after the sixteenth century old English Gothic



Art Model Pathéphone No. 450 English Gothic period. Both of these instruments were exhibited recently at the music show in New York and attracted considerable attention from dealers and music-lovers.

One of these models is known as No. 1000 and will retail at \$1,000. This instrument is an exact replica of a remarkable antique cabinet that is on display at the Metropolitan Museum



Another 16th Century Gothic Art Model Pathéphone No. 1000 in New York City, and which is recognized as one of the few genuine specimens of sixteenth century old English Gothic furniture.

The other art model is known as Pathéphone model No. 450, and is a reproduction of a sixteenth century English Gothic side table. This model will retail at \$450. Both of these instruments embody the stately proportion, the massive strength and the symbolic hand-carved designs which characterize old English Gothic furniture and which have made this style of furniture the subject of admiration century after century.

The Pathé Frères Co. has advised its jobbers and dealers that only a few of these cabinets have been manufactured and, according to present plans, no more will be made, as the company intends that whoever purchases one of these art models will have an exclusive design in his home.

THOMAS MFG. CO.'S NEW CATALOG

Various Styles of Dayton Motors, Tone Arms and Reproducers Illustrated and Described in Attractive New Volume Just Issued

The Thomas Mfg. Co., Dayton, O., have just issued their new sixty-four-page No. 4 phonographs catalog, a volume that in the matter of illustrations, typography and the wide variety of talking machine accessories shown leaves little to be desired. Of course, the various types of the Thomas Co. Dayton motors, tone arms and reproducers are illustrated and described in detail, and this alone takes up many pages of the catalog. Not only are the complete motors shown, for instance, but there are complete dimension drawings of each motor, carefully marked, as well as special plates showing the dissembled parts of each motor. All the parts are carefully lettered so that they may be ordered separately for replacement and repair purposes.

The Dayton motor is shown in four styles, namely, 6, 9, 11 and 31, the first three with double spring, and the last with triple spring equipment. Full details of each motor are printed in connection with the illustrations. Of the Dayton tone arms there are shown types 1, 2, 3, 4 and 5. Each tone arm is shown in various positions for playing the different types of records. One full page is given over to the Dayton reproducers and their various qualities; other pages to turntables, winding cranks, etc.

A particularly interesting section of the catalog is that devoted to phonograph instructions which include a wealth of information for the manufacturer and dealer regarding the assembling of phonographs, and the proper care of both machines and records. The instructions are carefully illustrated.

There is also much information for both manufacturers and dealers to be found in the pages devoted to motor essentials and the care of motors—information that should be read, and remembered by members of the industry because of its value and timeliness.

As an introduction to the catalog there is presented a most interesting summary of the origin and development of the phonograph. Of the Dayton products and the plant of the Thomas Mfg. Co. in which they are made there is also something said, and the "backbone" of the catalog is made up of a number of half-tone plates showing the plant of the company, as well as some excellent views of the various departments. These plates serve to give some

idea at least of the extent of the Thomas Mfg. Co.'s plant.

VICTOR CLUB FORMS SMOKE FUND

Members of the Victor Lunch Club at the factory in Camden have formed a Smoke Fund for the soldiers and are raising money by agreeing to abstain from smoking entirely each Monday and to contribute money thus saved to the fund. Any member caught smoking between midnight Sunday and midnight Monday is fined \$1, which fine also goes to the fund. It is said that several members have already found that it was worth \$1 to sneak a smoke during the forbidden twenty-four hours.

The Steinberg Piano Co., Augusta, Wis., has opened its new store in that city where they handle a full line of pianos, talking machines and music.

The Scotford Tonearm and Superior Universal Reproducer

The Ideal Combination

Plays All Makes of Records as they should be played

Price of Sample Prepaid

Nickel, \$5.25

Gold, \$6.50

Adjusted for Cabinet measuring 8 1/2 inches from center of Tonearm base to center of Turntable shaft

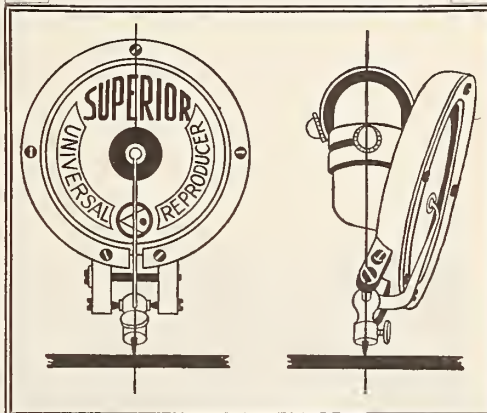

Distinctive Features

The Reproducer pivots on its axis (as illustrated above), taking the correct angle for all makes of records, and the needle retains same center in both positions.

Surface noise is less than with any other reproducer—surface scratchings being reduced to a minimum through perfect proportioning of the stylus construction, and placing the needle in the center of the groove at the correct angle.

The split construction of the frame and face ring of the Reproducer, together with the method of pivoting the stylus bar, and perfect insulation—effect a sensitive and free vibration—and prevent a pinched tone resulting at any time from natural contraction or expansion of the metal parts.

The reproduction is the mellow, natural quality of tone—absolutely getting a way from the usual sharpness and metallic effect so noticeable in most reproducers.

Sound waves act upon the same principle as light waves—they travel in a straight line until they meet some obstruction, from which they are deflected at right angles. The right angle turn at the back of the Scotford Tonearm causes less breaking up and confusion of the sound waves than occurs in the curved arm.

The connection between the Reproducer and Tonearm is perfectly insulated with a hard rubber bushing. Inside diameter of the Tonearm is correct to accommodate the volume obtained from the latest records.

The right-side turn for changing needle is handier than the old style turn-back, and when in position for the Hill-and-Dale records there is no interference with lowering the cabinet cover.

The lateral movement at the base is simple, free and permanently satisfactory. Inside there is no obstruction to interfere with passage of the sound waves. There are no loose balls in the bearings, therefore no buzzing noise can occur from the great vibration on high notes.



Barnhart Brothers & Spindler

Monroe and Throop Streets—Chicago



“Music and the Great Out-doors”
—A sales-slogan that sells Grafonolas
—Are you making it work for you?

Columbia Graphophone Co.
NEW YORK

AEOLIAN-VOCALION RECORDS SHOWN IN WINDOW EXHIBIT PITTSBURGH DEALERS' LATEST MOVE

Unusually Artistic Window Display at Aeolian Hall, Together With Extensive Advertising Campaign, Helps to Introduce the New Aeolian-Vocalion Records to the Public

Coincident with the formal announcement of the new Aeolian-Vocalion record, together with the extensive advertising campaign introduced in the newspapers, the Aeolian Co. recently featured in its handsome show windows at Aeolian

some time past. This display is presented herewith, although the photograph hardly does justice to the beautiful color scheme that formed its basis.

The Aeolian Co. has, for many years, made a



Artistic Window Featuring the New Aeolian-Vocalion Records

Hall one of the most artistic window displays that have been presented in the local trade for

specialty of unusual and decidedly original window displays, but during the past few months these windows have far out-distanced the displays of previous years in attractiveness, distinctiveness and sales appeal. F. W. Vreeland, of the Aeolian Co.'s advertising department, has been the directing spirit in the preparation of these displays, and his thorough knowledge of the basic principles of window dressing and the many years he spent in the study of art have enabled him to prepare displays that have won the hearty approval of the public and art critics.

The Vocalion Record window shown herewith conveyed an effective message that contributed materially to the remarkable success achieved by the Aeolian Co. during the first week of its Vocalion record demonstration. This record is gaining in popularity day by day, and has won commendation from musicians and music lovers.

EDISON MEN CELEBRATE FLAG DAY

With fitting ceremony, the employes of the Thomas A. Edison industries celebrated Flag Day by holding a regular community sing, giving the salute of the flag and pledge of allegiance and reciting the American's Creed.

Led by Ed Meeker and the Edison Employes' Band the assembled workers devoted the better part of the noon hour of June 14 singing the patriotic and popular song hits. T. J. Leonard, general sales manager of the musical phonograph division, delivered an inspiring, patriotic address, and the announcement was made that every Tuesday and Friday at 12.30 p. m. until further notice the Edison employes would gather in front of the laboratory for such a community sing.

Pittsburgh Talking Machine Dealers' Association Passes Resolution to Withhold Support From Enemy Language Newspapers

PITTSBURGH, PA., July 2.—The Pittsburgh Talking Machine Dealers' Association recently caused some stir in the trade by passing a resolution to “intern” all records by German artists, as well as records of German music for the period of the war, and has passed another resolution along patriotic lines, pledging its members to withhold all support of every kind from any publication printed in the language of any enemy country. The resolution reads:

Whereas, We believe the reading of newspapers and periodicals printed in the language of the nations allied against the United States in the present war tends to foster the speech, the traditions and the principles of those nations, and to that extent obstructs the education of our foreign-born population in the duties and privileges of American citizenship and the principles of true democracy; and

Whereas, We believe the publication, distribution and reading of such newspapers and periodicals throughout the United States should be discouraged and their patrons led to a study of the English language by making them dependent entirely upon English publications for all current information in print:

Be It Therefore Resolved, That the members of this association withdraw all advertising from publications printed in German or in the language of any other nation now or hereafter allied with Germany in the present war, and that copies of this resolution be supplied to the trade with the recommendation that similar action be taken in other communities.

JOINS PATHE TRAVELING STAFF

Marshall Brugman, formerly a member of the phonograph division of Thos. A. Edison, Inc., has been appointed a member of the traveling staff of the Pathé Frères Phonograph Co., Brooklyn, N. Y.

“The Music Without the Blur!”

This ideal of talking machine manufacture is attained more nearly than by any other, in the construction of the

MARVELOUS MAGNOLA “Built by Tone Specialists”

“Magnola's Tone Deflector eliminates the scratch”

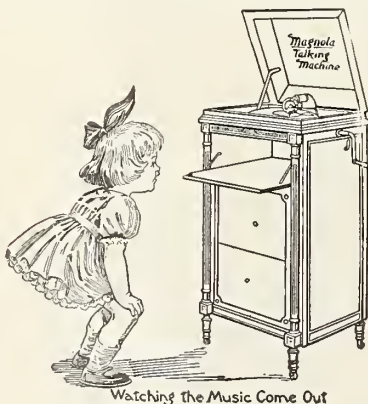

Watching the Music Come Out

We want to show you how to make money with MAGNOLA; and how MAGNOLA is the best buy on the Talking Machine Market to-day.

Send us your name and let us send you some real Talker Tips.

MAGNOLA TALKING MACHINE COMPANY

OTTO SCHULZ, President

General Offices 711 MILWAUKEE AVENUE CHICAGO
 Southern Wholesale Branch 1530 CANDLER BLDG. ATLANTA, GA.

DEALERS

Make Big Money

On Our Language Records



FRENCH, SPANISH
 ITALIAN, ETC.

ALSO

F. M. C. FRENCH
 MILITARY
 CONVERSATION

Cash in now on the

Language Phone Method

and Rosenthal's Practical Linguistry

It requires no scientific salesmanship to sell our records. The courses are so simply arranged that the demonstration satisfies the prospect. The French Military Course, 5 Double Discs, and Military Manual, (Retail \$10.00) is ideal for Army, Navy, Red Cross

Excellent Line for Summer Trade

Send for Particulars

THE LANGUAGE PHONE METHOD
 992 Putnam • 2 West 45th Street, - New York

The Victor Talking Machine Co. Sets Forth, Officially, Its Present Position

In view of the many rumors that have been circulated about the trade regarding the effect of the recent court decisions on the business of the Victor Co., and more particularly upon the present status of the company as a producing factor, owing to the handling of certain war work at the factory, the Victor Talking Machine Co. has issued the following official and interesting statement through the medium of the latest issue of the "Voice of the Victor":

"The times, as Shakespeare observed, are out of joint. Just as the great world about us has been driven by the war to face new conditions in social, economic and political life, so the particular business in which we are engaged has got to adjust itself to unprecedented events; but one of the results of this condition is that the Victor Talking Machine Co. has been the subject of many rumors. Some of these are hardly worthy of consideration, others again are so closely bound up with probabilities or possibilities that it is difficult either to deny or affirm them, but the real facts in the case are not such as to warrant any feeling of alarm to patriotic Americans.

"It has been rumored, for instance, that the Victor Talking Machine Co. is so busily engaged in Government work that it is about to give up making Victrolas in order to concentrate on records, or that it is almost out of shellac and cannot make records, etc. That the company is doing a certain amount of Government work is a fact; that it contemplates giving up the manufacture of Victrolas is untrue. For obvious reasons, we can give out no information as to the nature or extent of the work this company is doing for the Government, as such information could not fail to be of value to the

enemy. In such conditions, rumors are bound to flourish, and it is very hard to confute them with facts, since the facts themselves are not always available, and, as in the case mentioned, they are not ours to disclose.

"Many rumors have also arisen out of the recent legal decision in which the Victor Talking Machine Co. was concerned. The Victor business grew up under a system of fixed prices which was perfectly legal at the time it was established. Changes in the law made it necessary from time to time to alter the conditions under which Victrolas and Victor records were sold to the public. Recent legal decisions make it clear that the Victor Co. cannot proceed under the old fixed price systems, but the Victor Co. for some time has been making no effort to do so.

"Mr. Geissler's letter to the trade makes this matter perfectly clear. The recent court decision is the winding up of an old case based on methods which had long been discontinued. Obviously, then, any rumors that suggest or tend to suggest that the Victor Co. is to be 'dissolved' or put out of business are false.

"Over and above all these are many rumors due to the extraordinary conditions that arise just now as a result of labor shortage, transportation difficulties by land and sea, money values, coal shortage, difficulty in securing materials, the constant alteration of living conditions, and the thousand and one perplexities that occasionally baffle the most far-sighted management and are incident to all manufacturing industries.

"The moment the United States declared war this company placed itself at the service of the Government. Hundreds of our young men have left the factory and executive offices to take

part in war activities. These things have not deterred us from keeping things as normal as possible in abnormal times in the conduct of our business, and will not do so. We were compelled to reduce the issue of new records in an effort to overcome the shortage caused by a huge increase in our orders, and subsequently we were compelled to raise prices. But always in these varying conditions we have kept before us the desire to further the interests of the trade to the utmost.

"If, before giving credence to vague rumors, you will look back upon the actual facts of Victor progress under war conditions, you will at once realize there is no occasion to be alarmed. Whatever demands the Government makes upon us will be met, because there is only one purpose in American hearts to-day, and that is to win the war, cost what it may.

"This simply means that the Victor Talking Machine Co. is in business at the old stand in Camden, and, regardless of rumor, will maintain as closely as possible the same service as before the war. There will be no changes other than circumstances dictate, and any restrictions which the Government may place upon us will be imposed also on other manufacturers of like character.

"When any changes are made, the Victor trade will hear all that is to be heard from properly accredited sources.

"One overwhelming and incontrovertible fact testifying to the ever-increasing prestige and popularity of Victor products and their international use is, that orders on hand at the factory to-day are doubly as large on Victrolas and eight times greater on records than they were one year ago to-day—need any more be said?"

LONG CABINETS



No. 83

In all finishes. Specially adapted for use with Columbia 50. Front posts made to follow lines of posts on Columbia 75.

FIRST and FOREMOST

In the cabinet field.

Why? Because we've *specialized* in

CONSTRUCTION FINISH and ADAPTABILITY

Our supremacy in these essentials warrants your handling *the perfect line*.

That's why you should anticipate your wants **NOW**.



No. 79

In all finishes. Shown with top moulding and shelves. Specially adapted for use with Victrola IX-A.

Prompt deliveries on all orders. Write for Illustrated Catalogue of complete line

THE GEO. A. LONG CABINET COMPANY
HANOVER, PA.

ARTISTIC HEINEMAN CATALOG

Admirably Prepared Volume in Which the Heineman Motors of Quality Are Illustrated and Described Just Issued by Manufacturers

The Otto Heineman Phonograph Supply Co., New York, has just issued an artistic catalog featuring the Heineman "Motor of Quality." This catalog lists the various motors that comprise this company's line; each motor being featured on a full page with appropriate descriptions. On other pages are presented a detailed list of parts comprising the different motors, so that the manufacturers and dealers are afforded maximum convenience when ordering parts for the different types of motors.

There are seven different motors featured in this catalog, but accompanying the new publication was the following important notice regarding the Otto Heineman Co.'s co-operation with the Government in the restriction of its product: "Owing to conditions in the raw material market, due to the necessary Government work going on at this time, coupled with the scarcity of experienced labor, it has been deemed advisable to restrict our line of motors to certain types. We will supply motors No. 33, No. 77 and No. 44—this variety will cover the complete line of phonographs from small ones to the very best. By confining our production efforts in this manner we can assure our customer the very best service and deliveries."

The frontispiece of this new catalog presents a half dozen views taken at the Heineman factory in Elyria, O., including a bird's-eye view of the general factory, together with interior views which give a fair idea of the magnitude of this plant.

Following the descriptions of the various motors is an important section devoted to other products of this company, including Heineman tone arms and sound boxes, which have achieved country-wide success; tone arms and horn brackets and phonograph horns. Under the heading of "Care and Adjustment of Motors" valuable information is presented, accompanied by interesting diagrams that show at first hand just how maximum efficiency may be obtained in the use of Heineman motors.

The introduction to the catalog proper, signed by Otto Heineman, president of the company, reads in part as follows:

"In presenting this catalog to our customers and prospective phonograph manufacturers, we believe it will prove valuable and assist in the

selection of equipment best adapted to their requirements.

"Our factories and production have been increased many fold in the past years.

"The unsurpassed manufacturing facilities and organization have admitted of greater specialization of work in the various departments with corresponding improvement, refinement and uniformity of our product.

"As pioneers in the world's phonograph trade, Heineman motors have steadily maintained a leading position in the trade and we shall continue our efforts to manufacture always 'Motors of Quality.'

"New features are being designed constantly by our engineering and experimental laboratories and, when proven, are incorporated in the line of motors, so that the phonograph manufacturer can always feel that his machine will contain the latest design of mechanical equipment.

"Tone arms and sound boxes manufactured by this company are of the finest design and construction, manufactured from the highest grade of material. A representative stock of phonograph equipment is carried at our warehouses in cities where our branches are located."

CLEANING UP PAST DUE ACCOUNTS

Details of a Letter That Brought Good Results to One Merchant

Here is a letter that one merchant sent to those customers whose accounts were past due. It brought in better returns than any other letter he had ever sent out, says Clarence T. Hubbard in System, and because of this it may interest talking machine dealers:

For two days my wife has been after me to mail a letter and I just this minute got to it. Funny, isn't it! Two days to mail a simple little letter and here in this office I haven't been late for fifteen years.

I get my business letters out on time all right. But this letter "just sort of" kept slipping my mind. I felt awfully mean about it. Each morning I was determined to mail that envelope, but one thing and another bobbed up and pressed it out of my mind.

To-day I mailed it. I wrote a memorandum about it on the face of my watch so I wouldn't forget it. The deed is done and it is such a relief.

But I know what the trouble was—I was asked to do something out of the regular course. That's where we all fall down. There are so many things in the regular course of affairs that we forget these little things.

You've been hung up the same way, I know. That little bill you owe me—\$23.40, to be exact—has been crowded out of your mind because it was something out of your regular course of affairs.

Just take this letter as a memorandum, will you? Send me a check to-day and that sense of relief will be yours.

TALKING MACHINE DEALERS

—READ THIS—

"The finest and most delicate pieces of mechanism do not prove efficient unless properly lubricated. Skill, Genius, Invention and Workmanship must have the proper Oil. Stop and consider this when you have to buy an Oil for household use."

NYOIL
IS BEST

FOR ANY TALKING MACHINE



Being made in our Watch Oil Dep't, the same care given in refining as in our "Watch Oil," as all gums and impurities are extracted, leaving it Colorless, Odorless and Stainless.

BWARE OF SCENTED OILS

Machines will not clog if oiled with NYOIL. NYOIL is used by the U. S. Gov't in Army and Navy. A trial order will make a permanent customer of you.

Ladies use NYOIL for Sewing Machines, for it is stainless.

Sportsmen find NYOIL best for Guns, for it keeps them from rusting.

NYOIL is put up in 1oz., 3 1/4 oz. and 8 oz. Bottles, and in Pint, Quart and Gallon Cans.

For Sale by all Talking Machine Supplies Dealers
WILLIAM F. NYE, New Bedford, Mass., U. S. A.

PORTFOLIO FOR USE OF SALESMEN

Prompted by the request of Columbia dealers the dealer service department of the Columbia Graphophone Co. has prepared a special leather-covered loose-leaf portfolio of original Grafonola photographs for the use of salesmen and canvassers connected with the dealers' sales



The Columbia Portfolio

forces. This portfolio has been made in a convenient pocket size. A semi-stiff leather cover with a gold embossed trade-mark and a pocket in the last inside cover for salesmen's papers make this portfolio a handy and convenient aid to salesmen and canvassers in conveying an intelligent idea of the attractiveness of the different Columbia Grafonolas. The semi-flexible cover protects the photograph, while the loose-leaf feature makes possible the change of individual model instrument photographs whenever necessary. The handy size makes it convenient for piano and furniture store collectors or solicitors to talk Grafonolas when making their daily rounds.

LAYTON BROS.' MEN ARE PATRIOTIC

George H. Brennan, who was formerly manager of the Ottawa branch of the R. S. Williams & Sons Co., Ltd., resigned a short while ago to take over the managership of the phonograph department of Layton Brothers at Montreal. Learning that a battalion was being formed in Montreal and that they were minus a phonograph, Mr. Brennan conceived a splendid idea of having the employes of Layton Brothers subscribe the necessary amount to buy a New Edison Army and Navy model. All the employes responded nobly to the request, the phonograph has been ordered and the presentation will be made very shortly with proper and fitting ceremony. Thanks to the efforts of Mr. Brennan, these Montreal soldiers will be able to have re-created music to cheer them on their journey to the battlefields of France.

In all things throughout the world, the man who looks for the crooked will see the crooked, and the man who looks for the straight will see the straight.—Ruskin.

MELOPHONE MOTOR

No. 1

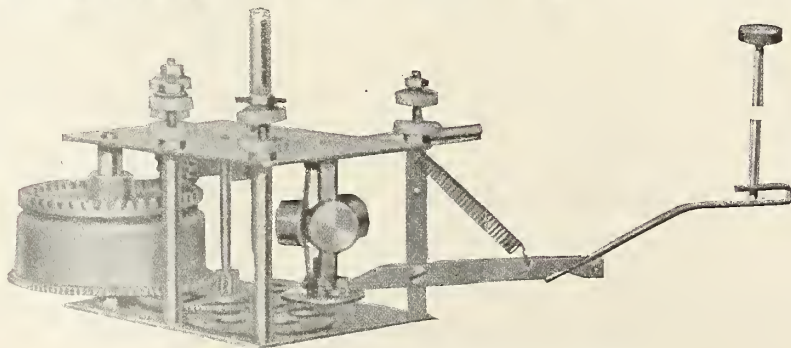

No. 1

COMPLETE WITH 10-INCH TURN TABLE

Simple in construction, the most satisfactory and durable of all small motors.

Will play two ten-inch records with one winding.

Three years' successful record as the best single spring motor manufactured.

Immediate Deliveries Sample \$2.00

Write for Quantity Prices

Melophone Talking Machine Co.

380 Lafayette Street, New York



By these men we shall conquer!

The world must be made safe for democracy: Here are the men who will make it so.

The moral and spiritual forces that will carry us on to victory no man can measure. The books you send, the letters you write, the music the men have to enjoy—do not for one moment underestimate the weight they will throw into the final balance of success.

The pictures shown here are typical of the spirit of Uncle Sam. He has a song in his heart, a tune on his Yankee lips, and an iron resolve deep in his liberty-loving soul.

This company is proud that its products are a mighty Armament of Hope, cheering and strengthening the spirit of our fighting men.

In camp and trench, on transport and battleship, in hospital, church and cantonment, in the welfare houses of the Y. M. C. A., the K. of C., and the Y. M. H. A. the Victrola is the unflagging, and often the *only*, source of music and entertainment. It is so portable that it can be taken anywhere and *unaided* it gives forth the music and laughter of the world's greatest artists. The Victrola is teaching wireless and French to our Army and Navy. Victrolas and Victor Records are day and night advancing the cause of freedom on the battlefields of the entire world.

Every Victrola in the service of Uncle Sam is a source of actual war strength. Every Victor Record at the front is a winged messenger of victory, doing its humble, but by no means unimportant bit to vanquish the powers of darkness and make the world safe for democracy.

Victor Talking Machine Co., Camden, N. J., U. S. A.

The Victrola enlisted in the War for Democracy

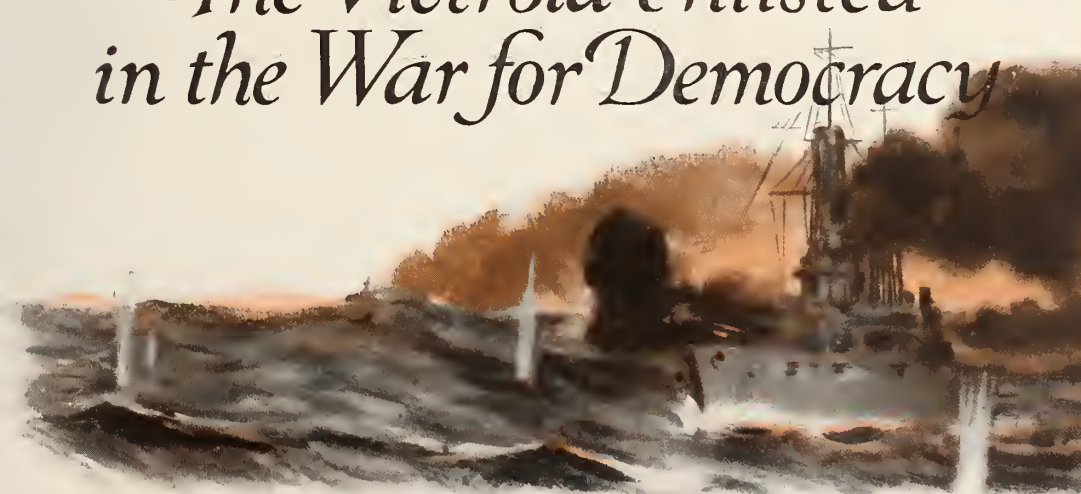

110th Regiment Infantry at Philadelphia en route to Camp Hancock, Georgia.



Italian troops enjoy a Victrola concert on the snow-clad Alps.



U. S. Jackies, U. S. S. "Delaware," entertaining themselves with the Victrola.



British Tank officers of the "Iron Cavalry" and their Victrola somewhere in France.



Listening to the Victrola at Camp Dix, New Jersey.



A merry hour at Fort Jay, Governor's Island, New York.

In times of war as in times of peace, the Victrola performs a mighty service to the Nation.

This interesting and attractive Victor advertisement, which appears on the back covers, center spreads, and inside color pages of the Saturday Evening Post, Literary Digest, Every Week, Delineator, Designer, Woman's Magazine, People's Home Journal, and other magazines, shows and tells the important part the Victrola plays in the lives of our fighting forces.

It makes the millions of readers of these publications familiar with the war-time necessity of the Victrola, and presents new opportunities to Victor retailers.

Moulding the American Citizen



Appreciation with the Victrola,
George W. High School



Dancing the Ace of Diamonds,
Waipahu School, Waipahu, Oahu, Territory of Hawaii



Kindergarten Children, close on national flag
Under the Stars and Stripes, South Park



Collingswood, N. J., Sun-



Roller Skating,
Public School, No. 100, New York City



Business Men's Class
Y. M. C. A., Spartanburg, S. C.



Kindergarten Games
224 District, No. 1 School, Milwaukee, Wis.

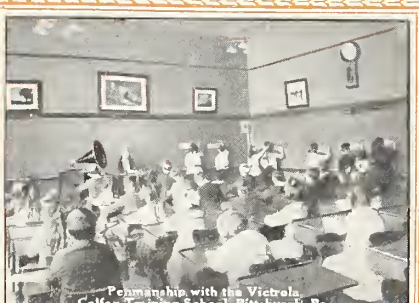

Penmanship with the Victrola,
Colfax Training School, Pittsburgh, Pa.



Friends' Central School, Philadelphia

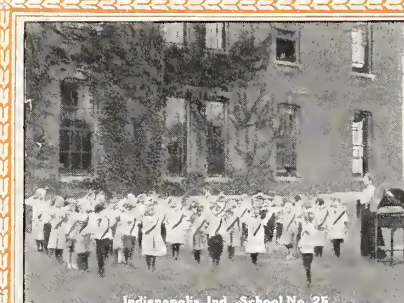

Indianapolis, Ind., School No. 25

Victrola:

Before the advent of the Victrola, the public schools were seriously handicapped in the study of music. Now Caruso and Melba sing to the children in the dreariest and most remote of rural district schools. Now the coming generations of Americans—the future bulwark of the state—listen day in and day out to the piano of Paderewski, the violin of Mischa Elman, the sweet soprano of Alma Gluck, the golden tenor of John McCormack. They live in the ennobling atmosphere of the world's musical masterpieces, sung and played by the world's supreme artists. This priceless benefit has been bestowed upon them by the Victrola.

The Victrola is in daily use in the public schools of 6000 cities and towns. It is in the regular equipment of more than 25,000 public schools, urban and rural. It has become an indispensable auxiliary in the educational system of every state, from kindergarten to university.

Endorsed by the
foremost educators



To insure Victor quality, al-
mark "His Master's Voice,"
the Victor Talking

Among the schools of our country the Victor is also doing a vast work in the education of Young America.

It is one of the greatest educational forces in the world today, and the advertisement similar to the above which appeared in the center spreads of the Saturday Evening Post and Literary Digest presented the fact in an interesting manner and attracted

zen of Tomorrow



Class in History of Music,
Western College for Women, Oxford, Ohio



Girls' Class in Rhythmic Expression,
Margret Wilson Social Center, Grover Cleveland School,
Washington, D. C.

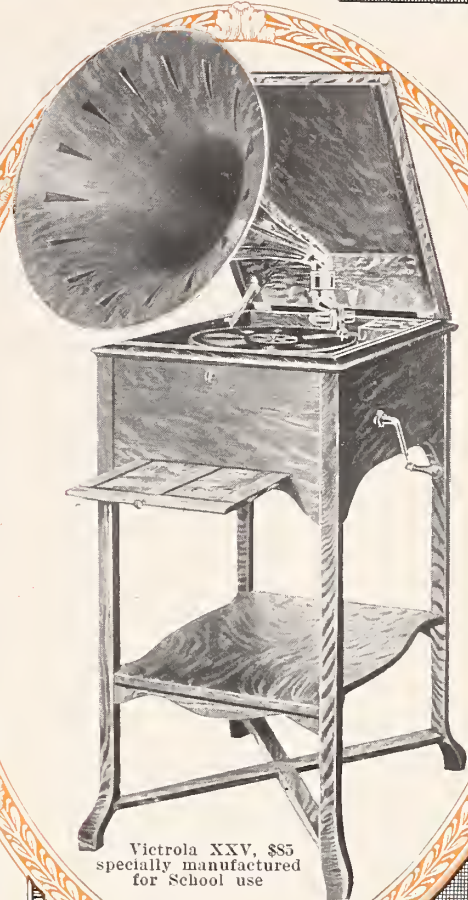

Victrola XXV, \$85
specially manufactured
for school use

Its great constructive service to the nation

The Victrola is performing an incalculable service in the teaching of our national patriotic music, the folk lore of the ages, the art treasures of all mankind. It is illuminating and vitalizing the study of history, literature and geography. It is teaching wireless telegraphy to our Army and Navy. It is teaching French to the soldiers of Uncle Sam.

The Victrola is used in calisthenics, folk dances, rote songs, ear training, nature study, penmanship, typewriting, folk song, art songs, ballads, operatic and orchestral music, vocal training, and community singing. New and authoritative study courses are constantly being supplied by our large and expert Educational Department.

The America of tomorrow will owe much to the Victrola.

Victor Talking Machine Co., Camden, N. J., U. S. A.
Berliner Gramophone Co., Montreal, Canadian Distributors

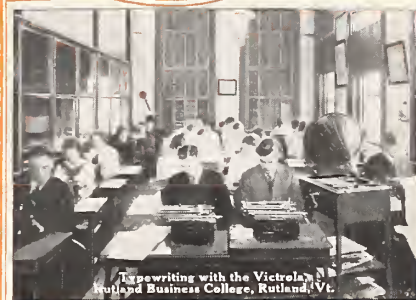

Typewriting with the Victrola,
Rutland Business College, Rutland, Vt.



The Victrola in use at a Rural School,
near Huntsville, Ala.



"HIS VOICE"
PAT. OFF.

Used in more than 25,000 public schools



Joseph Hoffman School,
Cincinnati, Ohio

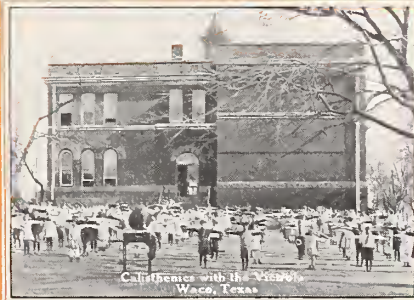

Calisthenics with the Victrola,
Waco, Texas



Maypole Dance,
Maybin School, New Orleans, La.

Look for the famous trade-mark on all genuine products of the Victor Talking Machine Company.

W.D.T.

the attention of the millions of readers throughout the country.

This phase of Victor usefulness is one in which every Victor retailer can take a hand with benefit to his community, and with profit and prestige to himself.



"HIS MASTER'S VOICE"
REG. U.S. PAT. OFF.

To insure Victor quality, always look for the famous trademark, "His Master's Voice." It is on all products of the Victor Talking Machine Company.



Victrola IV-A, \$22.50
Oak



Victrola VI-A, \$32.50
Oak

Victor Supremacy

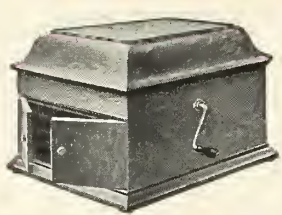

Victrola VIII-A, \$50
Oak



Victrola IX-A, \$60
Mahogany or oak

Through its use in the army and navy as well as in home and school, through its study courses teaching French and wireless to our soldiers and sailors, the Victrola is constantly extending its field of usefulness to meet the needs of the times.

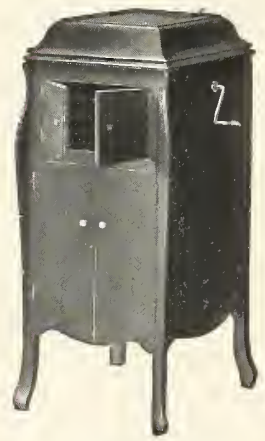

Victrola X-A, \$90
Mahogany or oak



Victrola XI-A, \$115
Mahogany or oak

It is daily becoming a still greater asset to every Victor retailer.



Victrola XIV, \$175
Mahogany or oak



Victrola XVI, \$225
Victrola XVI, electric, \$282.50
Mahogany or oak



Victrola XVII, \$275
Victrola XVII, electric, \$332.50
Mahogany or oak

BUFFALO TALKING MACHINE MEN IN WAR STAMP DRIVE

Members of Trade Work Hard and Subscribe Generously—Draft Depleting Local Sales Staffs—Increased Street Car Fares Expected to Help Neighborhood Stores

BUFFALO, N. Y., July 5.—Unstinted effort and generous financial support to the great W. S. S. drive held here the last week in June was given by the Buffalo talking machine jobbers and dealers. The following committee covered the retail and jobbing houses, including all local music dealers:

C. N. Andrews, chairman; O. L. Neil, O. M. Kiess and William H. Daniels. The amount of the subscriptions collected by Mr. Andrews and his committee totaled \$15,055. The following each subscribed \$1,000 in the campaign: C. N. Andrews, individually; W. D. & C. N. Andrews, as a firm; William H. Daniels, individually; Denton, Cottier & Daniels, as a firm; Neal, Clark & Neal; O. M. Kiess, manager of the Columbia branch; Robert L. Loud, W. F. Gould and Arthur Erion. The talking machine dealers and jobbers responded enthusiastically and tangibly to the worthy cause. In this trade the sale of W. S. S. was considerably heavier than in several other lines of business.

W. S. S. pledge cards were signed by every employe of the Columbia branch. The action put this branch in the "100 per cent. subscription" class. D. M. Green, manager of the Columbia's record stock department, has enlisted in the navy. Fred Gaulin, repairman for this branch, has joined the colors and is at Camp Upton.

"Our business was hindered in June on account of the shortage of machines," said O. M. Kiess, manager of the Columbia branch. "Our stockroom is cleaned out of machines and we are oversold by \$30,000 to \$40,000 in the Buffalo territory."

William Herbert, salesman for W. D. & C. N. Andrews, has donned a uniform of the U. S. Army. He is at Camp Upton. F. P. Besser, a former employe of this firm, is a regimental sergeant major in the 106th Field Artillery.

The draft is depleting the sales forces of the local talking machine stores. The dealers expect still greater difficulties, when, it is said, the Government will require salesmen in the draft age to engage in some kind of war work. Young women, boys under the draft age and older men may soon be in demand at the stores.

S. C. Eigenbrod, manager of the talking machine department of the Brunswick-Balke-Collender Co., has returned from a two weeks' vacation.

The tendency towards the advance of fares on trolley and steam roads is likely to help the talking machine and record trade at the neighborhood stores in this territory. Rather than pay the higher fares, many will prefer to shop near home.

The donation of a Victrola and other equipment has been requested by the National League for Women's Service. The members have been given the task of fitting out three big rooms

in the technical high school as recreation and club quarters for the 1,100 soldiers who will be trained there in July and August.

Near the entrance to the talking machine department of J. N. Adam & Co. Lieutenant T. M. Minton, of the New York Naval Reserves, recently displayed the Minton collection of historical flags. The exhibition was free.

Posters showing a talking machine labeled "American Citizen Phonograph" are being displayed at the local stores. According to the picture, "You Can't Play That Record on This Machine," confronts an alien who tries to place in the machine a record entitled "Deutschland Ueber Alles."

"Gyp" dealers, who used to rent stores here for a short period and sell cheap talking ma-

chines and other musical instruments, have struck a snag. In the near future these transients will probably have to pay a special tax, make a report of gross sales to the city and file a surety bond.

Charles H. Utley, new Edison dealer, who died recently, left an estate of \$40,000 or more to his widow and son, Charles B. Utley.

The last week in June was the banner business week of the year for the Verbeck Musical Sales Co., Columbia and Delpheon dealers.

The War Service Club, of the William Hanger Co., Victrola dealers, recently aided in the sale of War Savings and Thrift Stamps, by giving an outdoor entertainment.

Many Buffalonians who are living in cramped quarters on account of the shortage of flats and houses say they would be more interested in the purchase of the higher-priced talking machine if they could only find adequate homes. The Government is studying the housing problem, as it affects war workers in this territory.

CONTROLS FOURTEEN STORES

A. L. Bailey of St. Johnsbury, Vt., Has Establishments in Vermont, New Hampshire and New York States With Competent Managers

ST. JOHNSBURY, VT., July 6.—Reference was made in the correspondence from this city in last month's World to A. L. Bailey, the prominent piano dealer with headquarters in this city, who controls fourteen stores in Vermont, New Hampshire and New York, taking the agency for the Columbia line in this city, and some other of the Bailey stores. He has built up a very strong organization, having managers for all his stores, with the exception of Lancaster, Berlin and Colebrook, N. H., which are under the management of G. R. Magoon.

The addition of the Columbia line of talking machines and records to this large chain of stores is certainly an important move, which will tend to make this instrument a much larger clientele. Apart from his keen and active interest in the development of his music trade interests, Mr. Bailey is president of the Citizens' Savings Bank & Trust Co., of St. Johnsbury, and his views in financial, as in business matters are respected and esteemed.

PATHE DEMONSTRATION RECORD

Now Being Introduced That Should Excite Public Interest—Is Part of Advertising Campaign

The advertising department of the Pathé Frères Phonograph Co., Brooklyn, N. Y., advised the trade this week of the introduction of a Pathé demonstration record which is now ready for distribution. This is a twelve-inch double-face Pathé disc record, one side featuring a unique method of introducing the merits of Pathé reproduction of the human voice and musical instruments, and the reverse side contains a quartet selection which has won praise from musical experts.

This record will be furnished to the dealers on a basis which will enable them to offer it to the public at 25 cents, and an intensive advertising campaign is being prepared whereby Pathé dealers will be given every opportunity to feature this record to excellent advantage. Judging from the enthusiastic comments of Pathé representatives who have visited the executive offices the past week, this demonstration disc will prove an invaluable help in developing Pathé record business and demonstrating to the public that Pathé records can be played on any make of talking machine.

LANGUAGE PHONE METHOD POPULAR

Many New Dealers Are Featuring the Language Records and Co-operating in the Drive Being Carried On by the Company—Method Proving Particularly Valuable in Military Work

The Language Phone Method, 2 West Forty-fifth street, is making a big drive on their language records and the number of dealers that have co-operated in making it a success are steadily increasing. The dealers who have taken over the course have been stimulated by their success into further co-operation and many of them are featuring the courses in window displays. Among the New York dealers who recently had displays are G. Schirmer, Inc., The Ideal Music Shop and Herbert & Huesgen. These constitute the first series of displays and arrangements are now being made for others.

The Language Phone Method has been recommended by the Y. M. C. A. National War Work Council and is being used extensively throughout the military training camps. P. J. Doherty, sales manager of the Language Phone Method states: "It is proving a big seller for the dealers located near the training camps. Especially is this true in regards to the 'F. M. C.—French Military Conversation,' a short course for soldiers. It is popular with the men, and dealers in the localities in which the camps are situated."



CABINETS

We have cabinets to match all Victor Victrolas ready for immediate delivery.

Write us for Quotation

MAGIC-TONE STEEL NEEDLES



Prices Immediate Delivery Loud Tone

55c per thousand and in lots of 500,000 and up.

In lots of 100,000—60c per thousand
In lots of 10,000—65c per thousand

In paper envelopes or metal boxes

Anticipate your requirements and take advantage of present low prices.

I. DAVEGA, Jr., Inc.

Victor Factory Wholesalers

125 West 125th Street

NEW YORK

VICTROLAS—SUPPLIES—NEEDLES



Maybe a little local advertising would speed up sales on Vacation Grafonolas. We have some splendid Dealer Electrotypes. Want them?

Columbia Graphophone Co.
NEW YORK

EXPLOITS STRADIVARA PHONOGRAPH

Commercial and Sales Departments of Compton-Price Co. Now in Charge of Hugo Koch—A. O. Price Directing Technical Division—Individual Features of the Stradivara Machines

The Compton-Price Co., Coshocton, Ohio, have inaugurated a systematic and forceful campaign exploiting the Stradivara phonograph, which they have had on the market for some time, and for which they claim many superior features.

The commercial department, financing, sales and credits are now under the direct supervision of Hugo Koch, who has become well known in the talking machine trade through his connection with the industry as president of the Sahlstrom Corporation with stores in Portland, Ore., and San Francisco, Cal., who are successors to the Hudson Arms Co., a large sporting goods organization, which found handling the Stradivara so successful that a year ago the company was converted into a retail phonograph house exclusively. Mr. Koch, owing to his wide experience in merchandising phonographs, knows the requirements of the retail trade in every detail.

At the head of the technical department, and under whose supervision is the manufacturing of the Stradivara, is A. O. Price, well-known for his connection with the Compton-Price Co. for many years. Mr. Price has made a thorough study of the manufacturing of phonographs and his expert knowledge is reflected in the high-

grade workmanship which is to be found in the Stradivara.

The machines which this company offer range in retail price from \$60 to \$250, they having lately produced the Stradivara Grand in a very handsome art cabinet.

The Stradivara phonograph will play all makes of disc records, being equipped with an adjustable sound box. It is also equipped with a tone modifier, which may be utilized for the personal interpretation of a record, changing at will from the softest pianissimo effect to a full, loud tone. Another feature of the machine is an automatic stop which is simple in its construction as well as convenient.

The Stradivara tone arm is equipped with 100 steel ball-bearings, assuring a perfectly free travel of the needle across the record. It has no thumb-screws, but can be set in the desired position by a simple movement.

The company also makes a special point on the construction of the sound-board of the Stradivara, which they claim is constructed like the sound-board in a piano or a violin. The sound-board is made of spruce and great care is taken in its construction so that, according to a statement made by the company "it takes up the sound received, the over-tones so necessary to the natural reproducing of sound, augments them and adds life and color to each individual voice or instrument."

The cabinet work is of the very highest class, the best quality of veneers being used, and the highest class workmanship is found on the exterior as well as the interior. Each cabinet is equipped with a record filing device constituting vertical partitions, which are covered with a fine quality of green felt. In this way records may be ready at hand any time for use, easily found and kept free from dust.

The factory in which these machines are manufactured is one of the most up-to-date plants in the Middle West, and had been used exclusively for many years for the manufacture of pianos before the Stradivara phonograph was put on the market.

NEW VICTROLA PRICE CARDS

The Standard Talking Machine Co., Pittsburgh, Pa., Victor wholesalers, have just had prepared for the use of their dealers most attractive Victrola price cards for placing on top of machines on display. The cards have the style and price printed in yellow on a black ground, with the word "Victrola" standing out in rich red. They measure four by five inches and are supported by a stout easel on the back. The card is also provided with a looped string so that it may be suspended from the knob of the machine if desired.

ELECTRO-PLATING of PHONOGRAPH PARTS

AND MUSICAL INSTRUMENTS
Gold, Silver, Nickel and Antique Finishes
JOSEPH MUSANTE
168 CENTRE ST. Tel. Franklin 3053 NEW YORK

NEW HOFFAY REPRESENTATIVES

Prominent Concerns Secure Distributing Rights for Hoffay Talking Machine Co. Product—Two New Patents on Hoffay Sound Box

The Hoffay Talking Machine Co., Inc., have during the past few weeks closed negotiations with several firms for the distributing rights in their territories, and this, in addition to the large number of dealers who have in the present season been added to the Hoffay list of agents, has been very gratifying to Joseph Hoffay, president of the company. The demands for the Hoffay "Resurrectone" and the "Half-Fork-Tone," the patented sound box which the firm manufactures is constantly growing larger. Mr. Hoffay states while it is true that there are some manufacturers who are placing the above products on their instruments the largest demands are from dealers themselves who are making it a point to demonstrate the "Resurrectone" and "Half-Fork-Tone" on the machines they sell.

The Hoffay Talking Machine Co. have applied for two more patents on their sound box, and these together with those already allowed the company should add to the value of the Hoffay products, including the complete Hoffay machine.

The Jewish Welfare Building at Camp Upton has been equipped with a large size Victrola.

What More Can You Ask

All the features that go to make a talking machine *Profitably Salable* you will find as regular equipment of *Magnola*: "Built by Tone Specialists."



Watching the Music Come Out

Complete description of all these features is to be found in our *handsome illustrated catalog*, which we should like to send you. May we? Ask us to tell you our plans for your benefit!

MAGNOLA TALKING MACHINE COMPANY

OTTO SCHULZ, President
General Offices: 711 MILWAUKEE AVENUE CHICAGO
Southern Wholesale Branch: 1530 CANDLER BLDG. ATLANTA, GA.



DEALERS

Tell your customers how their phonographs may teach them a language by the

CORTINA Phone-Method

Increase your record sales by selling them Cortina language record sets. A timely set for which there has been a great demand is the Cortina Military French-English course.

Send for full information. Advertising matter and poster-hangers free.

Cortina Academy of Languages
12 East 46th Street :: New York

PHONOGRAPHS WITH THE ARMY

25,000 Sonora Portable Phonographs Now in Service With British Troops, Says the Binghamton Phonograph Co. in Interesting Article

Under the heading "Phonographs With the Army," the Binghamton Phonograph Co., Inc., Binghamton, N. Y., recently inserted in its local newspapers an interesting article that called attention to the many Sonora portable phonographs which are in use among the armies of the Allied nations. This company handles the Sonora line, and the article which is reproduced below conveying a timely and effective message to the conveyed public:

"Over in the trenches and behind the lines phonographs are busily playing to entertain the soldiers in their off-duty hours. There's nothing like a man up and make him forget the cold, and the wet, and the troubles and dangers which he encounters.

"Obviously, it is impossible to lug around big musical instruments when ammunition, food and supplies demand every cubic foot of space available. It is because of this that the portable phonographs are utilized so generally.

"The Sonora Phonograph Sales Co., of New York, recently reported that over 25,000 of the Sonora portable-type phonographs had been sold through their London representatives and were now in service with the British troops along the battle zone. This particular Portable Sonora is proving immensely popular, not only with the soldier and sailor boys, but with motorists, vacationists, owners of country homes, college boys and girls and all who enjoy good music, but can't transport a heavy machine.

"The little portable Sonora in its polished cowhide case looks like a small suit case and, though it plays beautifully all makes of disc records, all sizes, it weighs fifteen pounds complete. In the great war hospitals physicians find the phonograph invaluable. It cheers up the

DIRECTOR OF CONSERVATION TELLS OF CURTAILMENT

U. S. Fuel Administration Depending Upon Gentleman's Agreement With Talking Machine and Piano Manufacturers to Curtail Use of Fuel 30 Per Cent., He Says—No Mandatory Order

For the last couple of months, and, in fact, since it was announced that the manufacturers of pianos were to curtail their use of fuel and consequently, it was believed, their output by 30 per cent. there has been much discussion pro and con as to the status of the talking machine manufacturer in the eyes of the United States Fuel Administration. There are those who declared that no curtailment order existed. Others that Washington had requested a curtailment of 30 per cent., and still others who held no views but wanted to find out. There have been several meetings held of talking machine manufacturers, and committees selected by these manufacturers to discuss the question of curtailment of output, but no satisfying announcement has been made as to the findings in these meetings.

In order to set at rest the mind of the manufacturer who is in the dark as to whether or

not he should curtail his use of fuel or his output at the present time, The Talking Machine World took up the question with Hon. P. B. Noyes, Director of Conservation of the United States Fuel Administration, who stated officially: "There is at this time no actual curtailment order directed against either the talking machine or piano industry. Both the manufacturers of talking machines and pianos have, however, agreed that they would curtail their use of fuel 30 per cent. In other words, this is in the nature of a gentleman's agreement, rather than a mandatory order."

In short, the director's statement means that the talking machine manufacturing trade is under a voluntary agreement to curtail the use of fuel 30 per cent., and the Government, relying upon the keeping of this agreement, has issued no direct order in the matter.

patients and in severe cases exercises a marvelous influence in aiding recovery. The patient helped by music frequently is out of the hospital a month earlier than he would be were he left in dismal quiet. The phonograph is indeed proving valuable in these trying times."

TALKING MACHINE EXPORTS

The Figures for April Presented—Exports Show Machines and Records Both Increase

WASHINGTON, D. C., July 3.—In the summary of exports and imports of the commerce of the United States for the month of April, 1918 (the latest period for which it has been compiled), which has just been issued, the following figures appear:

Talking machines to the number of 8,558, valued at 254,022 were exported in April, 1918, as compared with 6,460 talking machines, valued

at \$222,730, sent abroad in the same period of 1917. The total exports of records and supplies for April, 1918, were valued at \$177,973, as compared with \$127,435 in April, 1917. For the ten months' total 78,833 talking machines were exported, valued at \$2,168,752, in April, 1918, and 62,606 talking machines, valued at \$1,612,957, in 1917, while records and supplies, valued at \$1,653,390 were sent abroad during 1918, as against \$1,257,530 in 1917.

Earl Ford has been appointed receiver for the Lehman Furniture & Talking Machine Co., Huntsville, Ala., following the enlistment of Luther Lehman, manager of the company, in the navy, which left the house without an active head.

Many a young man just now begins to realize the opportunity to take that "trip abroad" about which he has been dreaming these many years.

The Leonard Markels BUTTERFLY MOTOR

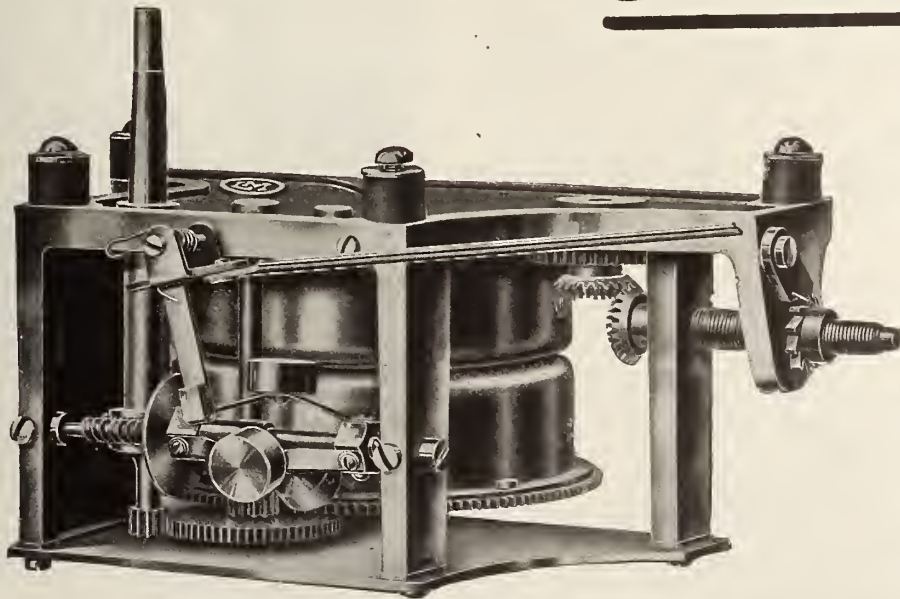

The Leonard Markels Jewel Bearing Butterfly Motor

has revolutionized the motor industry. It is silent running and silent winding and represents the acme of perfection in motor construction.

This motor has achieved phenomenal success, and is being used exclusively by leading phonograph manufacturers in all parts of this country and Canada.

Write today for a copy of our **New Butterfly folder**

Specifications

- Beveled gear noiseless winding,
- New ratchet device that prevents clicking.
- Bakelite intermediate gear—absolutely silent.
- Plays seven 10-inch or five 12-inch records at one winding.
- Cast iron nickered frame.
- Powerful, durable, compact, accessible.
- Built especially for the highest-grade machines.
- Guaranteed in every minutest detail.

LEONARD MARKELS - 165 William St., New York

THE TRADE IN PHILADELPHIA AND LOCALITY

PHILADELPHIA, PA., July 6.—Another month in the talking machine business has passed, and the first half of 1918 is only a memory. It has brought with it satisfaction, foreboding and regret. Satisfaction that it was not nearly as bad as it might have been in considering that we are in the midst of a war. It leaves in its path forebodings as to the future, which will keep the dealers on edge, as it has done during most of the six months past. And regrets that the manufacturers have found themselves in such a position that they have been unable to nearly supply the demand made upon them, thus relieving the dealers and jobbers of much profit that might have been theirs had they been able to get the goods.

In the securing of stock the month has been no better or no worse than the few preceding months. The promise for a great percentage of stock did not materialize. The dealers were able to get a portion of what they need, perhaps enough to satisfy and hold their customers, but with expenses rising at all times, and with the opportunity to meet them limited, there is no wonder that the dealers feel a little bit depressed at the outcome.

Report a Satisfactory Trade for June

H. A. Weymann & Son report that their talking machine business in June has been satisfactory, in spite of the shortness of stock. They are getting their full share, they believe, and have been able to keep their dealers in line, due to the fact that they started to look out for their interests months ago. By getting the dealers to order early they have kept them supplied in a way that some firms with less foresight have been unable to do. They could have done very much more business, both wholesale and retail, and yet they claim that they have no reason to complain. They have been compelled to work with a small force, many of their men having been ordered to the army for some months past, and during June two more men were taken, Arthur Appenzeller and George E. F. Hottel, of the retail department.

Removing to the New Home

The Penn Phonograph Co. are partly at their new home, 913 Arch street, and partly at their old home on Ninth street. All their machines are shipped from the new address and the rec-

TALKING MACHINE DEALERS

can greatly increase their profits without additional overhead expense, by selling the world-famous

Weymann "KEYSTONE STATE" Musical Instruments

a combination that has proved to be an instantaneous success.

Write for catalogue

H. A. WEYMANN & SON

Manufacturers

Victor
Wholesalers

1108 Chestnut St.
Philadelphia, Pa.

Established 1864

ord racks are being moved gradually in order that their business will not be handicapped. They are taking their time in moving, as there is no reason for hurry in any of the buildings. Their business last month was quite good, and it was ahead of June a year ago.

Expanding Cheney Representation

G. Dunbar Shewell, the representative in this section of the Cheney talking machine, is very well satisfied with the business he has been doing, and the agencies he has appointed in and near Philadelphia, as well as in Washington and Baltimore, cities included in his territory. Mr. Shewell was in Washington on Monday to close an important deal. He says that he has been

able to get his machines through in fine shape, and feels that he has been very fortunate in this respect.

Death of William A. Weymann

During the month William A. Weymann, who was in charge of the wholesale department of the Weymann store, and looked after the talk-



The Late William A. Weymann

ing machine end of the business, died suddenly at Atlantic City. He had not been in the best of health and had gone to the shore to recuperate, Mrs. Weymann accompanying him. After several days he had improved so rapidly that Mrs. Weymann returned to this city, and Mr. Weymann expected to remain several days longer. One morning, while strolling on the board walk, he was fatally stricken, and within a few hours he had expired. His death was a great shock to his family, as well as to a host of trade friends.

Mr. Weymann was forty-nine years of age and is survived by a widow, a daughter, Miss Helen Weymann, three sisters and two brothers,

THE reputation that the Penn Phonograph Co. attained in the past for efficient Victor Service is the Victor dealer's guarantee that he will get through the Penn organization the finest service possible under war conditions.

Penn Phonograph Co.

17 S. NINTH STREET

PHILADELPHIA

YOUR handicaps in both securing goods and in selling prompt us to make Buehn Service this summer more intensive than ever.

We also urge you to conserve physical energy in hot weather by doubling up your mail work. Use letters, supplements, mailing cards, and the telephone more liberally.

A most satisfactory summer sales volume will accumulate by selling more Victor records, particularly the higher priced numbers. Buehn Service is doing everything in its power for your interest.

THE LOUIS BUEHN COMPANY PHILADELPHIA

BUEHN SERVICE ON VICTOR RECORDS

Harry W. Weymann, president and general manager of the company, and Albert C. Weymann, who is secretary and treasurer of the company.

It is hard for his many relatives and friends to realize that one whom they had been accustomed to see always in a cheerful mood and at all times ready to extend the hand of good fellowship should have been called away so suddenly. He was so kind and considerate and beloved by all that the trade will consider his untimely death as the loss of a very dear personal friend.

Conditions With Louis Buehn Co.

The Louis Buehn Co. report that their business—in its conditions—has been about the same in June as it had been in May. Machines and records have been coming through in about the same proportion in June as they did for the two months that preceded it. Mr. Buehn is now located at the shore with his family, their cottage being at Ocean City, N. J., where he will spend his week-ends.

Patriotic Grafonola Men

The Columbia Grafonola Shops report that they have had a very good business. Manager R. L. Perrett says: "We have only been stopped by the amount of goods we can get." The firm will care for all the men's accounts in connection with War Chest subscriptions, as will be noted in the following letter received by Manager Perrett from Horatio G. Lloyd, chairman, executive committee, of the War Welfare Council of this city, which explains itself:

"Dear Sir—I am this morning in receipt of your letter of the 1st inst., and on behalf of the committee wish to assure you of our appreciation of your willingness to keep up the War Chest pledges made by those in your employ in case they should enter Government service, or be obliged to accept other positions at reduced salaries. It is a fine thing to do and we will appreciate it. We have, of course, recognized this as one of the risks of the twelve months' pledge system, but all the members of

the committee believe that much more will be realized, even allowing for certain losses, than could have been done by insisting on one payment or having it spread over a very brief period. With the precedent established by you I think it is very likely that we will be able to get others to follow your splendid lead."

Mr. Perrett states that the firm's business in June was three times larger than it was in June of 1917.

Some Personal Items

Mr. Sowden, who for a considerable time has been connected with the talking machine department of the Gimbel store, has resigned to accept a similar position with the firm of Harry C. Kahn & Son, Eleventh and Filbert streets.

Miss Margaret Robinson has been added to the talking machine department of the Strawbridge & Clothier store. Walter Wilson, of the same department, is at present away on his vacation.

Closed Good June Business

The George D. Ornstein Co., Victor jobbers, tell of a satisfactory business, and the same is reported from the firms which they supply in their territory. They have been able to keep a fairly liberal supply of both machines and records on hand.

A. D. Proudfit, who is in charge of the talking machine department at the Presser store, and Mrs. Quinby, who is in charge at the Estey store, both report that they have been having a most satisfactory business, and are well satisfied with the amount of goods they have been able to obtain through the Ornstein Co. Mrs. Quinby has quite a force working for her, and she has introduced a number of innovations into the business which have had their effect.

Blake Has No Cause for Complaint

Manager Blake, of the Edison Shop, Eleventh and Walnut streets, says that June was a very good month—the best they ever had by about 60 per cent. "July looks good to us," added Mr. Blake. "We are getting a nice stock of records and machines are coming in in a satisfactory way, and we have all we need of the latter. We

are laying in our fall stock now. If it comes all summer as it came in June we will have no cause whatever to complain, but will be most grateful." Ralph Ziegler, one of the Blake sales force, has been drafted and left for duty on Wednesday of this week.

Edison Dealers Meet

The Edison dealers had their monthly meeting on Tuesday evening of this week, which included a banquet at the Bingham House. They talked over their advertising and other important matters. There were no set speeches. Charles Gardiner was over from the factory and made a short address, and another guest at the banquet was R. B. Cope, of the Girard Phonograph Co.

Substantial Pathé Orders Placed

The Pathé Shop report that substantial fall orders are coming in from their dealers, and that a vast majority of them are anticipating the fall shortage and are placing orders now for these records, many of them to the limit of the amount of money they can find to invest. They got in several carloads of machines last month and are not only in a condition to take care of all orders at this time, but believe that they will have a sufficient stock of Pathéphones to take care of these orders.

Manager Eckhardt has taken a cottage at Atlantic City for the summer, and has removed his family there. The Pathé exhibition machine is doing duty at present on the Garden Pier at Atlantic City.

Selecting Their Representatives

The Brunswick-Balke-Collender Co. have been going ahead in a most satisfactory way and booking many orders for immediate delivery. The retail business among the dealers has shown a little falling off in June, but they all report that business looks unusually bright for the fall. They have placed the Brunswick machine with quite a few new dealers in June, but they have been most careful in their selection, desiring only the most representative dealers. As the manager says: "We have lots of applications,

(Continued on page 40)

VAN VEEN "BED-SET" BOOTHS



Install your booths during the summer and be ready for holiday business

WRITE FOR A COPY OF OUR NEW CATALOG

Van Veen "Bed-Set" Sectional Booths can be erected as easily as a bed (no skilled labor required). Booths shipped on short notice *anywhere*. Room sizes any multiple of 3 feet. High grade finish, will match your sample if desired. Sound-proof construction. We design and build complete interiors. We also build record racks, which are described in our new catalog.

Arthur L. Van Veen & Co. 47 West 34th Street, New York
TELEPHONE - - - GREELEY 4749

TRADE NEWS FROM PHILADELPHIA

(Continued from page 39)

but are taking only the very best, deeming it advisable to be careful as to whom we take. The firm will move the phonograph department to the second floor of the building, which they are fitting up in an extensive way in order to handle their rapidly-growing business."

Giving Good Service on Records

Manager R. J. Heath, of the Columbia Co. (wholesale), reports that their business has been remarkably good in June, and is still going along at a record-breaking pace. He says: "The Grafonola shipments are mighty scarce this month, due to embargo shipments, but we have been very fortunate in giving our dealers excellent service on records. Our record service has been remarkably good, due to the company's policy of advising the dealers beforehand

as to the advance in product, and many of the dealers have taken the opportunity to buy substantially in June of the smaller type Grafonolas, which advanced in price on July 1. Records will advance on August 1 and the dealers have been advised to this effect so that they may get in a supply before the advance actually takes place. This policy has met with the hearty approval of our dealers, making them feel that we are trying to watch out for their interests at all times."

John Neldine, who has been connected with the Columbia for a number of years in the wholesale department, has enlisted in the navy. C. B. O'Donnell, who has been in charge of the Columbia's record stock department, also enlisted in the navy in June.

F. K. Pennington, sales manager of the Columbia Co., was a recent visitor to his many friends in the local trade.

TRI-STATE ASSOCIATION DISCUSSES NATIONAL BODY

Believe That Local Organizations Should Act Together But Not Expand Beyond Present Confines
—Victor Dealers Pool Repair Work—Present Officers Continue to Officiate

St. Louis, Mo., July 5.—A good many inquiries have been received by the officers of the Tri-State Victor Dealers' Association from dealers over the country asking if the association could not be extended into a national organization. This matter has been discussed by the executive committee and the leaders in the local movement do not see their way clear to do this. They believe that the effectiveness of the association would be lost when its territory is extended beyond the distance at which dealers cannot easily come to two or three meetings a year. Already the membership of the Tri-State Association has been extended beyond expectations. The inquirers usually state they learned of the association's good work through the Talking Machine World.

But in making this decision, the local committee suggests that a national organization easily can be erected on the organization begun here by organizing a number of local associations in the chief trade centers where there is a jobber who is willing to undertake the work the Koerber-Brenner Music Co. has undertaken here. If a number of these organizations were formed, they could be nationalized by annual delegate meetings and in this way accomplish much good. But the leaders of the Tri-State Association believe that the most good from association work comes from the mingling of

the various members and the good feeling that results from social intercourse. They reason that a dealer will be much less apt to cut prices against a man with whom he has enjoyed a pleasant dinner than he would against a man concerning whom he knows nothing except reports carried to him by favor seeking customers. The social end is regarded as the chief feature.

An exceedingly successful meeting was held at the Century Boat Club the last week of June, and at this meeting a rough draft of a repair cost schedule was made. It will be completed and passed on to the members very soon. This

move naturally follows the change made recently whereby all Victor dealers gave up their mechanics and pooled their repair work in one shop, conducted by one of the best talking machine mechanics in this section. This move was made with a dual purpose, economy and the releasing of as many mechanics as possible for more necessary work. It has been known for many years that guarantees by dealers and charges for repairs were not uniform. The proposed schedule will define free service, fix a reasonable charge for all ordinary repairs and endeavor to have this practice made uniform. Under present conditions when dealers are entirely independent as to sales and are picking only those that they want to put on the books, it is believed that such a rule will be enforced.

There will be no further meetings of the association until September, at which time new officers will be elected. President A. B. Magoon and his staff were elected at the organization meeting as temporary officers and continued in office when the constitution was adopted, under the title of temporary officers. It is believed that the St. Louis trade district will be well organized under their direction by September, and then a general meeting will be planned to advance the work of the association still further. In the meantime President Magoon and the executive committee will hold weekly meetings, or oftener, if need be.

Chairman Ditzell, of the exchange department, says that this work already has transferred much dead stock from discard boxes to shelves where it will be readily sold. So far, this work has been confined almost entirely to records, but it has relieved some dealers of machines which were made to special order and then left on their hands.

PLEASED WITH PATHE PRODUCTS

The Pathé Frères Phonograph Co., Brooklyn, N. Y., recently received a very interesting letter from the Swanson & Nolan Supply Co., Pathé jobbers in Denver, Colo., referring to the splendid list of Pathé records that was issued in the August supplement. During the past few months the Pathé Frères Co. has received many letters from its jobbers reflecting enthusiasm and satisfaction with their products, and the following letter is a fair example of their spirit:

"August releases were received at this office this morning. To tell you what we think of this release in the usual way would be too mild. We can only say that if you keep this kind of stuff up we will have to draw on the United States Army for more help. Yours very truly, Swanson & Nolan Supply Co. (Signed) Earl D. Dryden."

HAPPINESS AND SERVICE

Happiness is a by-product. We can't buy it because it has no price. Some people try to purchase happiness by getting drunk; others build fine houses, and some travel around the world. But the goal is as elusive as the horizon. The main issue in life is service, and happiness is incidental to service.

The Marion County Board of Review has increased the tax valuation on the property of the Kipp Phonograph Co., Edison jobbers in Indianapolis, from \$25,000 to \$50,000.



THE REGINAPHONE

A phonograph of the highest grade with many exclusive features. The new Regina Sound-box is the greatest improvement in talking machines in years, reproducing all hill and dale and lateral cut records equally well, and in a manner unsurpassed.

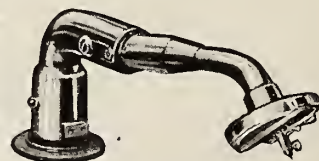

Territory arrangements with active dealers. Send for particulars.

THE REGINA CO. 47 West 34th Street, NEW YORK
209 S. Wabash Ave., CHICAGO, ILL

Manufacturers of the Regina Music Box and other musical instruments for over 25 years.



SERVICE

It has a bigger meaning today than ever before. In every walk of life we hear its appeal. We offer to our dealers dependable co-operation which takes in every branch of economy.

If our line has not already been introduced into your salesroom NOW is the time for us to become acquainted.

Each Nightingale is equipped with a Stephenson Precision-Made Motor and a Scotford Tone Arm and reproducer. We guarantee it unconditionally for a period of two years against broken or defective parts.

The selection of a phonograph is a serious matter. You must give perfect satisfaction to your customer and at the same time assure yourself of an adequate profit. On both these points the NIGHTINGALE scores big.

Your inquiry will be regarded as an opportunity to make the word NIGHTINGALE have a larger and more important meaning to your selling force.

Harry B. Wolfer
President

Nightingale Mfg. Co.
422-426 North Armour St., Chicago, Ill.

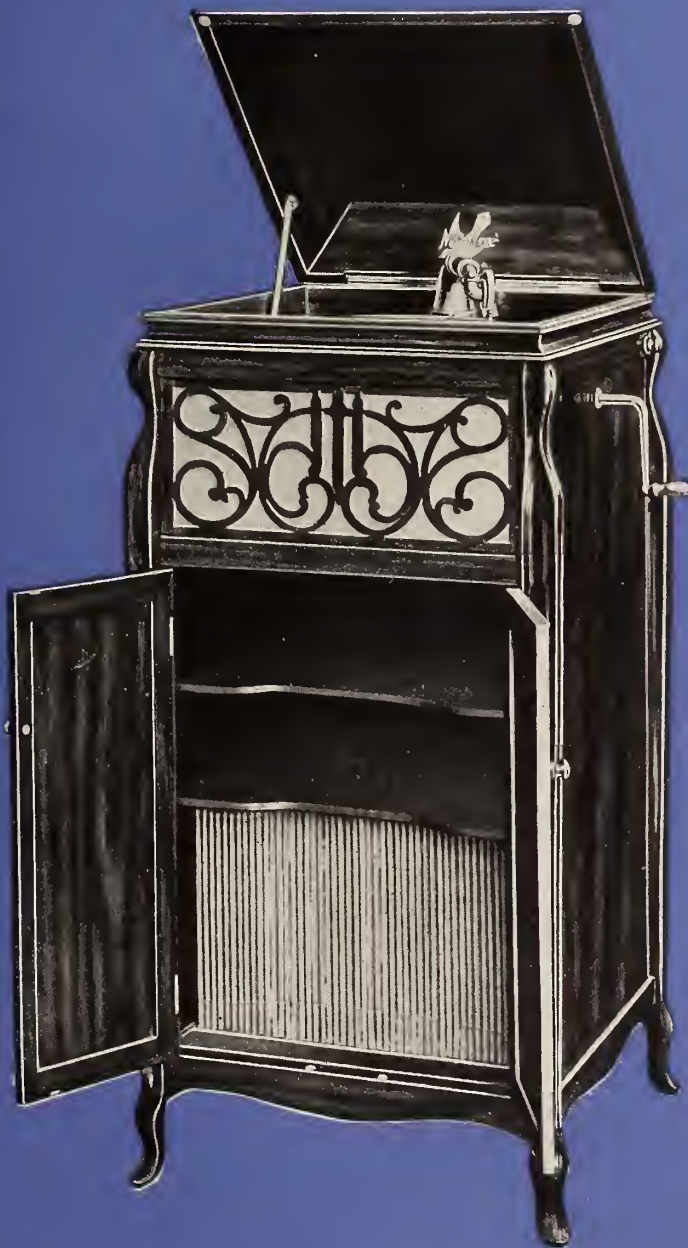

SHORTAGE OF STOCK IN TWIN CITIES

Big Demand for Victrolas Can't Be Met—Somers Co. Look for Better Pathé Shipments—Laurence Lucker Discusses the Situation

MINNEAPOLIS and ST. PAUL, MINN., July 8.—Many more talking machines could be sold in the Twin City territory than are now going out if the dealers could be supplied in accordance with their wants. But machines are not to be had, and that settles it.

George A. Mairs, head of the Victor department in W. J. Dyer & Bro., showed your correspondent a stack of letters the other day, beginning about as follows: "You may ship me at once ten Style X Victrolas" or "Please forward immediately six Style Q and six Style K." These men won't get anything except a polite note regretting that W. J. Dyer & Bro., although always attentive to the requests of their customers, are unable to supply their needs.

Harry J. Beach, who is one of the prominent men in the Victor forces, was in this vicinity last week to look over the stocks of W. J. Dyer & Bro., St. Paul, and the Beckwith-O'Neil Co. to ascertain for himself if the constant clamors for Victrolas were mere bear stories. He found the warerooms bare without any question, for there has been no chance to make any accumulation for a year.

Another big man, H. N. McMenimen, managing director of the Pathé Co., visited among the jobbers last week. He confessed to Jay H. Wheeler, manager of the phonograph department of the G. Sommers Co., that the company had not been treated any too generously, but promised to make some big shipments in the immediate future. Mr. Wheeler is doing an excellent business, much better than a year ago, but the trouble is that the orders are exhausting all his receipts and no reserve is being obtained for the inevitable rush of next fall.

"We know that the big rush is coming," said Mr. Wheeler, "and we are getting nervous already, for unless we get much heavier shipments

than of late we are going to disappoint our customers and lose some good business."

Shipments are coming fairly well for the Minnesota Phonograph Co. President Laurence H. Lucker understands fully that when grain and potatoes begin to move musical instruments will be sidetracked for indefinite periods and consequently he is straining every nerve to accumulate all the Edison phonographs he is able to lay his hands upon. He does not believe it will be possible to get any big shipments through after August 1. Mr. Lucker attended the meeting of Edison jobbers in New York last month and as usual found the gathering interesting and profitable.

SUGGEST GROUPING OF RECORDS

Talking Machine Dealers' Association of Buffalo at Recent Meeting Discuss and Act Upon Many Matters of General Interest to Trade

BUFFALO, N. Y., July 3.—At the last regular meeting of the Talking Machine Dealers' Association of Buffalo there was considerable discussion regarding ways and means for keeping mailing lists alive and up to date, and it was decided that dealers be requested to limit their mailing lists as much as possible. In the fall there will be taken up the question of sending out to all those on the mailing list a questionnaire in postcard form in order to ascertain the number who are anxious to receive the lists and other literature sent out by the dealers.

The secretary was instructed to write to the Victor Talking Machine Co. and present the following suggestions regarding the grouping of records:

1. That in grouping records in the catalog the numbers of the records be added. For instance, if one wishes to look up "Old-Time Ballads," or "Popular Songs," one must look up each song in order to get the number. In the case of "Marches" this has been done and is a great time-saver to the clerks and the public.

2. That the pages of the catalog be numbered,

ILSLEY'S GRAPHITE PHONT SPRING LUBRICANO

Ilseley's Lubricant makes the Motor make good
Is prepared in the proper consistency, will not run out, dry up, or become sticky or rancid. Remains in its original form indefinitely.
Write for special proposition to Jobbers.

MANUFACTURED BY
ILSLEY-DOUBLEDAY & CO., 229-231 Front St., New York
Established 1853

thus aiding the clerk to tell a customer just where to find a record.

3. That the German titles of records be changed into English both on the record and in the catalog as far as possible, and that they be cross-indexed in the catalog so that the German title would simply refer to the English title, for instance, under "Traumerei" see "Dreaming."

It was suggested at the meeting that the secretaries of the various associations of talking machine dealers throughout the country keep in touch with each other and exchange reports on actions taken at the various meetings in order to bring about closer co-operation between the organizations.

MAKING EXTENDED TRIP WEST

H. F. Thornell, General Sales Manager of Wilson-Laird Phonograph Co., Calling on Trade in West and Canada—Doing Well With the Phono-Lite and Other Specialties

H. F. Thornell, general sales manager of the Wilson-Laird Phonograph Co., New York, sole distributor for the Bliss reproducer, left New York the first of the month for an extended trip, which will include a visit to the leading cities in the Middle West, and also a call upon the trade in Canada. Mr. Thornell expects to spend most of his time on this trip with manufacturers and jobbers, and in view of the fact that many inquiries have been received the past few weeks regarding the use of the Bliss reproducer, he expects to close several important deals before returning to New York.

The Wilson-Laird Phonograph Co. has also made arrangements whereby it has become the distributor for two successful lighting devices; one of these being known as the Phono-Lite, and the other as the Disc-Lite. Both of these lights have proven very successful since their introduction to the trade, and Mr. Thornell expects to establish several distributing connections for these products upon his present trip.

A recent department inaugurated by this company in order to co-operate with the users of the Bliss reproducer is known as the "service department," and this department will aim to assist the manufacturers using the Bliss reproducer along practical lines. This department will be under the general supervision of Mr. Thornell, whose many years' experience in the talking machine industry will doubtless be reflected in the service rendered the manufacturers.

J. NEWCOMB BLACKMAN HONORED

J. Newcomb Blackman, president of the Blackman Talking Machine Co., New York, Victor wholesalers, has been elected a member of the executive committee of the American Fair Trade League, one of the most prominent business organizations in the country. Mr. Blackman was previously a member of the advisory committee of the league, and has been an active worker in behalf of the interests of this organization. The executive committee of the American Fair Trade League comprises some of the most successful members of the industrial world, one of its members being Louis F. Geissler, general manager of the Victor Talking Machine Co.

JOINS U. S. MARINES

Alfred C. Randolph, who has been associated with the local wholesale branch of the Columbia Graphophone Co. for the past six years, is now a member of the 157th Company of the U. S. Marines, and is stationed at present at Paris Island, S. C.

The Perfect Tone
OPEROLLO
For Every Home



MODEL "F"

Distributors
Wall-Kane
Needles

Distributors
Lyric
Records

40 inches high

18 inches deep

15 inches wide

RETAIL \$45

Write for Special Discounts of ALL our Models

Immediate Deliveries in Any Quantity

OPEROLLO-PHONOGRAPH COMPANY
54 W. Lafayette Blvd. Detroit, Mich.

Advantages of Street Car Advertising Outlined for the Benefit of the Dealer :: :: By W. Leroy Marshall

Advertising Dep't Victor Co.

"My very best salesmen, young men that I had trained for years, joined the colors. Yes, certainly, I was glad they signed up with Uncle Sam—I encouraged them, but later I found it necessary to advertise immediately for men to replace my experienced salesmen temporarily. The labor market had apparently gone dry. Then I realized that energetic, experienced sales-

ing basis." Our Uncle Sam comes first, but downhill business won't help win the war. Thrift and prosperity will.

Of all the better-known forms of publicity, street car advertising is perhaps one of the most effective methods of reaching the greatest number of people at a minimum of expense. No one will deny that our national advertising is

far reaching and influential, yet there is a gap that every Victor merchant should fill. While we can and do create the demand, you can with profit to yourself inform the people of your community that you stand ready to serve them. Years ago we concluded to assume a considerable portion of the expense of local street car advertising. Our share is

to supply attractive cards, beautifully printed or lithographed in four or more brilliant colors. Furthermore, we imprint your name and address on as many cards as you contract to use. Right now we have in stock sixteen different styles, each particular style carrying a convincing message, readable at a single glance, a message that couples your name with our national advertising, designed to catch the eye of prospective customers when they are in a most favorable position. Conditions favor in the highest degree the enterprising merchant who realizes the possibilities of advertising to the passengers on street railways very often confronted with a long, uninteresting ride with nothing to occupy their immediate attention. Furthermore, they may intend to shop in your very neighborhood, -yes, even in the store next door to you.

If you prefer to determine for yourself the value of street car advertising, start in on a small scale, probably beginning with those cars that pass your store or within a few blocks of your store. The cost in practically every case is relatively small as compared to the number of people that will read your

advertisement day by day. Street car advertising will back up the efforts of your sales organization as well as fill in the breach created by the shortage of efficient salesmen.

A postal card will bring you samples and suggestions, if you desire. If you want blank cards for your show window, they may be secured from the wholesaler. Imprinted cards may be



The Appeal to the Church-Goer men were becoming increasingly difficult to secure.

"To increase my local advertising seemed the only possible way to fill in the breach. Yes, it paid. While it's not business 'better than usual,' it's business on a most satisfactory 'paying basis.' Your street car cards helped me

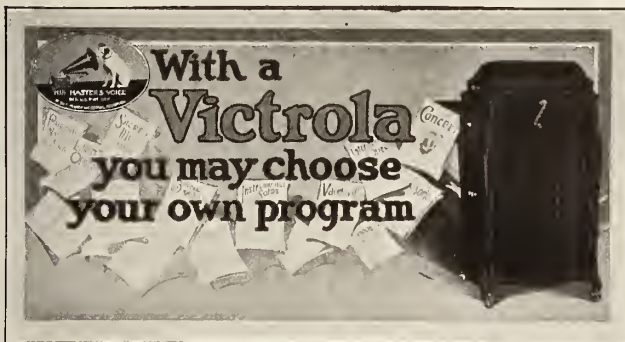

For the Interest of the Music Lover when I needed help, and I shall continue to use them."

The foregoing by an enterprising Victor merchant prompts us to bring to your attention the value of street car advertising in order that you may keep your business on the same "pay-



The Argument for the Summer Hostess

ordered direct from the Victor Co. This is in very truth the age of advertising and talking machine men must not lag behind.'

MUSIC FOR THE ITALIANS

American Red Cross Places Orders So That Music May Play Its Part on the Italian Front

Finding that twenty-five out of every hundred Italian soldiers stopping at the rolling canteens of the American Red Cross along the Italian front are able to play some instrument, Lieutenant McKay, in charge, has ordered a number of mandolins and guitars. From volunteers he has organized an orchestra to entertain the two thousand to twenty-five hundred men who daily enjoy bread, jam, hot coffee and cigarettes at the canteen. The personnel of the orchestra changes as the men come and go to the front. The talking machine, which plays when the orchestra is not on duty, has proved so popular that it will be loaded on a mule and sent to outlying batteries along the Italian front.

The Automatic Entertainers Corp., of Manhattan, was incorporated at Albany this week, for the purpose of conducting a phonograph business. Capital \$25,000. Those interested are P. J. Donohue, W. J. Kelly and W. J. Peavey.



Reproducer

The New Phonograph Phon d'Amour The New Wonder

Our patented diaphragm and reproducer give that clean, clear, snappy, mellow tone. There is no mushiness, no sharp or tinny sound. Our reproducer is suited for every purpose. It is adapted for brass band, popular song work, for violin and piano solos and for operatic sopranos, taking the high notes with such clearness and distinctness that it is the marvel of musicians and singers of renown.



Copyright, 1917, by The Fritsch Phonograph Co. Trade Mark

THE FRITZSCH PHONOGRAPH COMPANY

228-230 West 7th Street

CINCINNATI, OHIO



CLOSED

**Convenient—Compact—
Solid—Knock-proof—
Weather-proof**

Strong fibre case coated inside and out with water-proof varnish. Army Green color.

List Price \$65

No Needles to Change

The Pathé Sapphire Ball takes the place of needles. It need not be changed.

Long Life to Records

The Pathé Sapphire Ball cannot possibly cut, grind, rip or mar the record's surface.

The Pathe Controla

With the Pathé Controla you may increase or decrease the tonal volume of the Pathé Phonograph at will.

Plays All Records

Each Pathé Phonograph plays not only Pathé Records, but all other makes of disc records, and plays them perfectly.



MURATORE—Exclusive Pathé Artist

Here it is!—

the New

Pathé



Army and Navy Model

The newest portable model of the Pathé Phonograph.

The only Phonograph ready just as it stands to ship or take into an automobile. No packing to bother with at all. Just let down the cover and lock.

The first—the *only* Phonograph *entirely* suitable to sell those who want a phonograph for

- Travel or Vacation—Camp Use.
- Soldiers in Camp and Trenches.
- Sailors in Barracks or on Board Ship.

Write for Pathé Dealer Proposition.

Pathé Frères Phonograph Company

20 Grand Avenue

Brooklyn, New York

Pathé Frères Phonograph Co. of Canada, Ltd., Toronto



Some of the *New Pathe Records*

20385	{ HAWAIIAN NIGHTS—Waltzes. Louise and Ferera Hawaiian Orchestra. SOMEWHERE IN HAWAII. Louise and Ferera Hawaiian Orchestra.	10-in. 75c.	29207	{ MILITARY WALTZ. American Republic Band. WHILE THE INCENSE IS BURNING (Medley Fox-trot). Intro.: "Rose Room Fox-trot." American Republic Band.	12-in. \$1.00
20388	{ WON'T YOU BE A DEAR, DEAR DADDY? The Farber Girls. THEY WERE ALL OUT OF STEP BUT JIM. Constance Farber, Contralto.	10-in. 75c.	29208	{ TEN LITTLE BRIDESMAIDS. Jack Norworth, Baritone. I STOPPED, AND I LOOKED, AND I LISTENED! Jack Norworth, Baritone.	12-in. \$1.00
20391	{ WE STOPPED THEM AT THE MARNE. Arthur Fields and Invincible Four. IF HE CAN FIGHT LIKE HE CAN LOVE, GOOD-NIGHT GERMANY! Arthur Fields, Baritone.	10-in. 75c.	25016	{ THERE'S A LONG, LONG TRAIL. Percy Hemus and His Buddy Boys. KHAKI SAMMY. Percy Hemus, Baritone.	10-in. \$1.00
20392	{ THOSE DRAFTIN' BLUES. Arthur Collins, Baritone. IF YOU'RE CRAZY ABOUT THE WOMEN, YOU'RE NOT CRAZY AT ALL. Joe Remington, Baritone.	10-in. 75c.	71002	{ OH! LOOK! Medley Fox-trot. Intro.: "Typical Topical Tunes," "A Kiss For Cinderella," "I'm Always Chasing Rainbows." American Republic Band. SWEET LITTLE BUTTERCUP Medley One-step. Intro.: "Cleopatra" from "Sinbad." American Republic Band.	14-in. \$1.25
20393	{ YOUR LIPS ARE NO MAN'S LAND BUT MINE. Campbell and Burr. OUR COUNTRY'S IN IT NOW. Invincible Four (Male Quartet).	10-in. 75c.			

Summer

Everybody stocking up on popular records.

Buying the *most* of the Dealer with the most, newest popular hits.

Run your eye over the partial list of Pathe's "newest."

Right! You certainly should write to

Pathé Frères Phonograph Company

20 Grand Avenue Brooklyn, New York

Pathé Frères Phonograph Co. of Canada, Ltd., Toronto



Claudia Muzio

Exclusive Pathe Artist

BLUE DEVILS ENTERTAINED AT EDISON LABORATORIES

Famous French Soldiers Spend Enjoyable Day as Guests of Thomas A. Edison and Mrs. Edison—Presented With Army and Navy Model Edison Phonograph—Mrs. Edison Host at Luncheon

Monday morning, June 17, the employees of Thomas A. Edison, Inc., Orange, N. J., were thrilled with the news that a number of the Blue Devils of France would pay a visit to the Edison

ranks, marched out of the laboratory and around to a specially-constructed platform to receive the cheers of the Edison workers.

They were introduced by Mr. Meadowcroft, Mr. Edison's assistant, and then Sergeant P. A. Servet delivered a very appropriate speech, emphasizing the love of France for America, saying in part: "We men of France are aware of how much America loves our country. You people in America can have no idea of how France loves America." The cheers that greeted this remark left no doubt in the hearts or minds of these gallant fighters of America's love for France.

Master Lester Steel, an American boy of

Banner," led by the Edison band. A few more pictures were taken and then came an unexpected and delightful surprise. The Blue Devils sang one of their own battle songs, which aroused tremendous enthusiasm.

Through a densely packed crowd the Chasseurs Alpines worked their way to the waiting automobiles and were driven to Mr. Edison's home, where Mrs. Edison and members of the Women's Club of the Oranges acted as hostesses. Lunch was served on the broad green lawns; and while the soldiers of France enjoyed the famous hospitality of Llewellyn Park, the Edison Choral Society and Edison band furnished the music.

After luncheon the party returned to the storage battery building, and under the guidance of R. A. Bachman inspected the plant from roof to cellar. These soldiers know the need of storage batteries and Edison storage batteries



Characteristic Pose of Mr. Edison

Mr. Meadowcroft, His Chief Assistant, Is Explaining What Is Desired of the "Wizard"

laboratories. About 12 o'clock they arrived in automobiles driven by members of the Newark and Orange National League for Women's Service.

As these French heroes entered the gates of the old red laboratory building at Lakeside avenue and Valley road Mr. Edison appeared to personally welcome them. Each member was introduced to Mr. Edison, who presented them with an Army and Navy model and a choice selection of the new Velvet Surface Re-Creations. When these fighters return to their beloved France they will carry with them this pleasant reminder of one of the greatest Americans they have met on their visit to America.

After a number of pictures had been taken and the Mutual film man had ground out a few hundred feet of film, the Chasseurs formed



Mr. and Mrs. Edison and the Army and Navy Model Phonograph Presented to the Blue Devils

French parentage, then sang "La Marseillaise," and the crowd answered with the "Star Spangled

are well known to them. Sergeant Servet was prevailed upon to say a few words to the workers and responded as follows:

"You soldiers of the factory, we soldiers of France greet you. This war will be won by the country who has the most men, guns, ammunition and airplanes. Particularly airplanes.

"Your job here is as noble as the soldier's. You are doing a wonderful work for your country and the Allies by your hard work. The results of your labors are absolutely needed by the men at the front. The soldiers are waiting for you—waiting for your work.

"You have been informed of the impossibility of successful warfare without aviation. Every commander, before he attacks, must know all possible about what is happening with the enemy, how he is situated and the ground to be fought over. The aviators furnish this information. What you are doing here will build up aviation and aid materially in winning the war.

"If airplanes are the eyes of the army, then you are the optical nerves.

"I was amazed to learn to-day that during the first six months of the war there were 2,500 strikes in America. The war can never be won if the country is divided this way. You must all work together.

"In my travels around I have been surprised, and at times grieved, by the vast amount of material lying around and the delays. The best message I can leave for you is 'speed up.' Forget your differences, bend all your energies toward winning the war and win we shall."

After each of the Blue Devils had signed Mrs. Edison's guest book, they were driven back to New York.



One of Many Groups of "Blue Devils" Guests of Mrs. Edison at Luncheon at Llewellyn Park

SHEDDING A LITTLE SUNSHINE INTO A GLOOM RETORT

How a Wise Kid Gets Hep to a Talking Machine Problem and Takes the Morgue Out of Mortgage—Feeding Classic Acorns to the Musical Nuts and Making Them Like It—Likewise Sticking the Indian Sign on the Pessimist—Get Jerry to This Stuff, It's the Right "Talker" Dope

A couple of months ago there was a gink in a small burg in the East who kidded himself that he was a talking machine dealer, but who, when it came to the low down, was simply an apostle of gloom hanging out in a store stocked with machines and records and with his John Hancock over the door. For a live guy to stroll into this bird's headquarters even on a sunshiny day was like stepping into the morgue after a catastrophe. He cried so much over hard times and war conditions that the dampness rusted the springs on the machines and even streaked the wall paper. To hear him tell it, the world in general, and the talking machine business in particular, was tougher than a pawnbroker's heart. Naturally the kale ran low in the till. It was a case of all going out and nothing coming in. Talking machine owners who wanted to go to funerals preferred to enjoy the ride in a hack rather than to listen to the old boy cry and, therefore, bought their records somewhere else, where the purveyor managed to smile a little even if it hurt.

With no trade to encourage his agony, this near dealer amused himself by counting up his machines and trying to figure out how long they would keep him in business. Then he would look at his stock of popular records and throw a spasm that would keep him in despair for the rest of the day. Every time the mail man came he got an attack of blind staggers, for whenever he sent off an order for a case full of nice pretty new records, all he got in return was a little package of discs by mail that looked about the size of a chorus girl's wardrobe. After every delivery of mail, the only thing that kept the old bird from pulling a finale via the gas route was because the meter was locked and he used electricity to light his store. The result was that his upper structure went blooey

and he was carted away lying down in a pretty black wagon labeled "ambulance."

Naturally the wife had to eat and bring up the family, so the only thing to do was to hire a clerk until the business was wound up, or the old man again returned and completed the wreck. The error was checked up in the old lady's batting average when she happened to hire a youthful proposition who still had some pep in him. He still had a few weeks to work before the draft got him, and didn't care where he hung his hat. The new man took one look at the store and began to cry himself, more in sorrow than in anger. Then having nothing else to do he polished up the machines, took a shovel and scraped the window to let the light in, and mowed the floor. After much effort the store lost its air of antiquity.

Still having a little leisure on his hands, the kid slips on a few records to entertain himself and dissipate the gloom. A swell frail blowing by the store falls for the high brow stuff, and saunters in to find out whence comes the melody. She slips the kid the info and it's the record she's been looking for for yea these many moons and demands another set-up of the same. The answer is that she hits the sidewalk ten seeds shy, but with eight slabs of symphonies under her wing. The kid tries the cash register but it's jammed. He hides the money and rings up the sale the next day after he has soaked the keys in crude oil. The shock of having real money in it knocked four of the cash register's keys out of commission.

The kid is musical. He grabs off the classic stuff inside, because he gets sick of the jazz stuff outside the store. By and by other musical nuts blow in and get their fill of the music that made the foreigners famous. The kid had to order more records, and not a popular one

on the list, and the wholesaler was so surprised he forgot to ask for the mazuma. The first frail breezes in again with a lot of new Janes and a couple of jobbies whose chief labor consists of working the old man's check book. In about three weeks the kid was being asked out to tea and to give his advice on musical subjects. He was there with both feet and a tongue and copped off all the business there was. The kind of records he was selling was the kind that could be bought from the wholesaler any time without trouble, and the orders came through 98 per cent. clean without a slip up.

The machines started to wiggle their castors and move out and the old lady started sniffing gasoline, so she could get used to the bus she was going to buy when a little more money came in, and leave it to the kid to get his while the getting was good. He picked up some info from the trade sheets and the company's dope book and was heeled for bear. He was wise to the fact that he could sell the records he had and could get, and need not waste his time on the jazz stuff that was away below par to keep going. In short, he turned the joint upside down and kept it as crowded with class as the tango parlor on the Avenue.

Finally the old man who owns the store gets wise to himself and blows out of the nut factory for home. He walks in the store, takes one glance, then goes bugs again—the shock is too much, and the old lady might just as well have been a widow. Give the kid about one year more and he will about own that store and a few more.

Moral: There isn't any moral to it, except to sell the stock on hand instead of what you hope to get.

SECURE COLUMBIA AGENCY

The Austin Furniture Co., 540 North Cicero street, Austin, Ill., has just taken the agency for the Columbia Grafonolas and records, and has opened a large department to handle that line.

"Unlike All Other Phonographs"

The CHENEY PHONOGRAPH Plays all records—better



Style Two Sheraton

Many phonographs play all records—only the Cheney plays all records—better.

It is *different*—because it embodies an entirely new application of acoustic principles to the problem of sound reproduction (covered by new basic patents).

Different—because it is not a megaphone type instrument.

Different—because it *does* play all records better.

Different—because it reproduces the human voice, violin, piano and all other instruments so literally, that the very personality of the artist is revealed.

Different—because each individual Cabinet is a gem, executed by master

artisans of the Berkey & Gay factories, accepted leaders and creators of the world's finest furniture.

Different—because the tone and appearance of the instrument endears itself perpetually to its purchaser.

Different—because our agency proposition is more attractive.

Different—because we put behind you a liberal advertising plan which benefits you directly.

Six Cheney Models, \$60 to \$300 Art Models, \$250 to \$2,000

CHENEY TALKING MACHINE COMPANY
24 No. Wabash Ave., Chicago

We invite correspondence



LISTEN!

DID YOU HEAR THE NEW TEN INCH

Operaphone Records

Order Now From A Catalog of 300 Selections

We want every dealer who sells talking machines equipped with a Universal tone arm to sell Operaphone Records. "One sells the other."

If you are selling phonographs then you should sell records to play on them.

Why lose the extra profit that belongs to you by allowing your machine customer to go elsewhere to buy records.

Records Are the Only Excuse for Phonographs

Operaphone Records are absolutely independent and are manufactured from start to finish in our own factory at Long Island City, New York.

Operaphone Records are known from coast to coast because they are the original steel needle vertical cut records and all others are imitators.

Here Are a Few of the Latest Broadway Hits That Will Sell on Demonstration

- | | | | |
|------|--|------|--|
| 5136 | { 'N' Everything, from "Sinbad"
Winter Garden Show | 5137 | { What Are You Going To Do To Help
The Boys? |
| | { K-K-K-Katy | | { Rock-A-Bye Baby With A Dixie Melody |
| 5138 | { The Last Long Mile, "Toot, Toot"
She's The Daughter Of Rosie O'Grady | 5145 | { I'm Sorry I Made You Cry
Homeward Bound |
| 5142 | { Lorraine, My Beautiful Alsace Lorraine
Where The Morning Glories Grow | 5140 | { Good-Bye, Barney Boy
Lafayette, We Hear You Calling |

Prompt deliveries all the time. Splendid Window Display

Write at once for our proposition and get at the profits

OPERAPHONE COMPANY, Inc.

Long Island City, New York



Happenings in Dominion of Canada

TORONTO TRADE KEEPS UP A LIVELY PACE THIS SUMMER

Frank Oldfield Signs Contract With Pathé Frères Co. to Make Records—Revised Prices Announced on Columbia Grafonolas and Records—Many Members of the Trade Join Army

TORONTO, ONT., July 5.—The popular Toronto singer, Frank Oldfield, has signed an exclusive contract with the Pathé Frères Phonograph Co., of Canada, to make records for them. He has already recorded several selections from his extensive repertoire and these records will shortly be on sale at all Pathé dealers. Included in the selections is "Sussex by the Sea," the song which Mr. Oldfield made famous in Canada.

The Music Supply Co. and the Victrola Service Co. are two new companies recently registered in Toronto.

Youthful local talent was much in evidence at the Children's Hour of Music held recently in Williams' recital hall. After the introductory feature which was a description of the opera "The Flying Dutchman," accompanied by some of the outstanding numbers from the opera recreated on the Edison phonograph the remaining portion of the program was carried out almost entirely by the children attending. The Children's Musical Hours every Saturday morning proved very popular with the school children of Toronto.

Massey Hall was filled to overflowing quite lately when Mme. Galli-Curci made her second appearance in this city. Every foot of available space was occupied, it being necessary to place several hundred chairs upon the stage. Both visits have been great triumphs for the gifted singer, and needless to say His Master's Voice dealers shared in a large distribution of her records.

F. Irving Brown has just resigned the position of manager of the Victrola department of the Robert Simpson Co., Ltd., to enter the army. Soon after Mr. Brown's joining the Simpson Co. organization in the autumn of 1917 the department took on "His Master's Voice" lines exclusively and an active and extensive business has been worked up.

James T. Bradt, general manager for Canada, for the Columbia Graphophone Co., recently addressed a letter to the company's dealers advising them of the revised prices on Columbia machines and records following the Government's action in imposing the recent 10 per cent. war tax. The fact was specially emphasized that in increasing prices the company had seen to it that the dealers' percentage of profit had not been reduced.

The new prices are: Grafonola—Type A, \$27; B, \$42; C, \$65; D, \$80; E, \$125; F, \$140; G, \$160; H, \$175; K, \$240; L, \$300, and Type X, \$110; Type G, electric, \$200; H, \$210; K, \$275; L, \$335, and horn Grafonola for schools, \$100; ten-inch records, heretofore listed at 85 cents, 90 cents.

On the occasion of the recent visit to Toronto of Carolina Lazzari, the Chicago Grand Opera contralto, and Arthur Middleton, formerly of the Metropolitan Opera Co., a reception was tendered these artists by R. S. Williams & Sons Co., Ltd., at the Williams' recital hall. A select list of music lovers were asked by private invitation to meet the singers in a social way.

To R. G. Cordingly, of Brockville, distributor in Eastern Ontario of the Aeolian-Vocalion, goes the sympathy of many trade and personal friends, in the death of his wife. After a very short illness Mrs. Cordingly succumbed to an attack of pneumonia.

Word has been received that Sergeant B. A. Trestrail, of the United States Army Medical Corps, has arrived safely in England. Before enlisting he was a popular member of the R. S. Williams & Sons Co., Ltd., Toronto staff.

Brunswick phonograph trade made a material advance during the informal opening of the new art parlors and recital hall at Stanley Piano Building this month. Extra space was badly

needed, as the previous facilities were outgrown. The new floor is what was formerly the art gallery.

George L. André, well known in advertising circles "in Toronto and elsewhere," and who for several years conducted the publicity department of Mason & Risch, Ltd., has been appointed advertising manager of the Pathé Frères Phonograph Co., of Canada, Ltd., with headquarters in Toronto.

EXCLUSIVE PHONOGRAPH SHOP OPENS UP IN MONTREAL

New Retail Concern Handling Representative Line—Goodwin's, Ltd., to Handle Victrola Line—Active Trade Reported by C. W. Lindsay, Ltd.—Brunswick Advance—Other News

MONTREAL, QUE., July 5.—The Exclusive Phonograph Shop, with Geo. S. Pequegnat, the well-known phonograph expert salesman, as manager, practically guarantees the success of Montreal's latest addition to the talker field. This store was opened to the public on June 15, and has been pronounced by experts to be one of the best-equipped phonograph stores in the Dominion. No detail has been overlooked in studying the comfort and requirements of their patrons. The Pathé, Aeolian-Vocalion and Lyric machines are being featured with Pathé, Columbia, Lyric, Gennett and Aeolian-Vocalion records. Sales of both machines and records at date of writing far surpass this firm's fondest expectations, and taking into consideration the particular season of the year augur well for the future.

At the monthly meeting of the employes and sales staff of Layton Bros. held recently it was decided to donate one Army and Navy model of the New Edison phonograph to the Twenty-third Reserve Battalion of Montreal, together with a selection of records. This step was taken by the employes following the return from the New York conference of W. W. O'Hara, sales manager, and Mr. Brennan, the manager of this concern's phonograph department, who told of the Army and Navy phonograph being made by T. A. Edison for use on transports, in the trenches and every place where soldiers are.

The committee in charge of the Soldiers' Home on d'Auteuil, Quebec (le chez Nous du Soldat), have just purchased from Gauvin & Courchesne a Victor No. X machine and a fine collection of Victor records.

There were imported into Canada during 1913 phonographs and records to the value of \$723,652; in 1917 this was increased to \$1,731,380.

Goodwin's, Ltd., of Montreal, one of the largest and best-known department stores in Canada, have qualified with Berliner Gramophone Co., Ltd., as dealers of "His Master's Voice" records. Goodwin's, Ltd., have conducted a phonograph department for several years, but now confine themselves exclusively to the Victor lines. We understand that Good-

The Starr Co., of Canada, have just celebrated the first anniversary of their entering business by removing into a new store on Dundas street, London, where much larger quarters are available.

Otis C. Dorian, general manager of the Pathé Frères Phonograph Co., of Canada, Ltd., has left on an extended trip through the Canadian West.

Among the new literature issued by Musical Instruments, Ltd., Toronto, manufacturers of the Cecilian Concertphone, is a dainty two-colored folder, illustrating five different types. This is for distribution by Cecilian dealers among prospective purchasers.

win's, Ltd., are entering on an aggressive campaign to feature "His Master's Voice" products and their service in this connection.

During the recent visit to Montreal of Caroline Lazzari this famous Edison artiste called at the showrooms of Layton Bros. and presented them with an autographed photo of herself, which is now framed and hung in the Edison Salon.

"While a great many of our customers are out of town for the summer months we are handling a goodly number of Columbia Grafonolas, Pathé and Sonora machines," said C. W. Lindsay, Ltd. "A considerable number of our patrons stocked up heavily on Columbia and Pathé records before proceeding to the country which helped considerably to swell our month's total volume of business." This firm are displaying in their handsome show windows a number of Sonora portable models.

Layton Bros. are delighted with the new Velvet Surface records. W. W. O'Hara, sales manager of this firm, who attended the convention of Edison dealers and addressed that body, returned home from New York full of new ideas which he intends putting into practice at an early date.

Miss Vezina, of Almy's, Ltd., still continues to find customers for Columbia goods and quotes a number of cash sales for the higher-priced types of Columbia Grafonolas. There has not been any perceptible falling off in the demand for Columbia records as yet, she states, even if summer dulness is apparent.

Manager Rampsberger, manager of the talking machine department of J. W. Shaw & Co., reports sales to be away in advance of the corresponding month a year ago.

"The Victor line is getting a most satisfactory proportion of buyers, and we have no complaint to make," said Foisy Frères, distributors of "His Master's Voice" products.

Charles Culross is finding the Aeolian-Vocalion and Sonora representations good lines to feature and notwithstanding the summer quietness is satisfied with the amount of business offering.

(Continued on page 50)

Talking Machine Supplies and Repair Parts

SPRINGS, SOUND BOX PARTS, NEEDLES

THE RENÉ MANUFACTURING CO.
MONTVALE, NEW JERSEY



The Biggest Dance Hit Ever! Marimbaphone Band Breezing through "Cotton Picker's Ball." It's Going great these days!

Columbia Graphophone Co.
NEW YORK

TRADE CONDITIONS IN THE DOMINION OF CANADA—(Continued from page 49)

The Canadian Graphophone & Piano Co. (A. A. Gagnier) is handling to good advantage the complete Columbia line and is looked upon as one of the largest exclusive local dealers.

Goodwin's, Ltd., have taken on the complete representation of the Sonora line, and their opening announcement in this regard occupied large-sized copy in all the local dailies.

Charles Culross, the Aeolian-Vocalion and Sonora representative, recently acted as Deputy Registrar, and during the Navy League campaign was captain of one of the teams in the retail merchants' section.

Local business is designated as moving along splendidly with H. P. Labelle, Ltd., and this firm are of the opinion that this fall will see more Pathé machines sold in Montreal than ever before.

The Brunswick Shop is most optimistic as regards the outlook for future business. They state people have lots of money and are spending it musically and they are getting their full share. A vigorous advertising campaign by the makers of this machine has been productive of results to this local firm that are indeed satisfactory to them, and a widespread local demand for Brunswick machines and records has been stimulated with the more expensive cabinet models in the ascendancy.

The Canadian Graphophone Co., jobbers of Columbia products in the Province of Quebec, are making active preparations for handling a big fall business. Commenting on present-day trade conditions they stated they were being accorded a full share of recognition, and that a large number of A1 Columbia Grafonola representations had been opened during the past month, while the demand for Columbia records has been exceptionally lively.

The Berlind Phonograph Co., Ltd., are disposing of a large number of Brunswick and Columbia models, both of which lines they say give every promise of enlargement of sales in the near future.

"You can say orders for Brunswick phonographs are unusually good," said Tom Cowan, of the Cowan Piano & Music Co., "and we anticipate a steady and still greater demand for fall selling."

Layton Bros. have the past few weeks had

some splendid examples of window dressing, in one instance the Edison Trench model was given more than due prominence in a setting of realistically banked sand bags with the instrument mounted on a businesslike gun carriage. The effect obtained was most unique in window trims and served to give the fullest prominence to this newest effort of Edison. The reproduction of the dugout required thirty full-sized bags of sawdust.

The following week depicted the record "I Don't Want to Get Well," in which was shown wax figures of Red Cross nurses administering to the wants of sick soldiers, who were shown in cots in side tents. A display of Edison and Columbia models of various sizes were prominently featured.

TRADE NEWS FROM WINNIPEG

**New Concerns Enter the Talking Machine Field
—Machine and Record Outfits in the Arctic—
A Recent Removal—General Happenings**

WINNIPEG, MAN., July 1.—The Morris Music Store, 1013 Government street, Victoria, B. C., is the name of a new store just opened up with a line of pianos, organs and His Master's Voice products and records.

Kenneth A. Ross, who has just returned from a visit to the Eastern centers will continue to make his headquarters in Edmonton though he will be traveling through Alberta and British Columbia. He is enthusiastic about the New Brunswick phonograph, which agency he has just secured.

C. B. Clark, the well-known music dealer of Calgary, Alta., has removed from Seventh avenue West to 216 Eighth avenue West. In addition to the Gerhard Heintzman agency Mr. Clark is an enthusiastic "His Master's Voice" dealer and has a good following from among Calgary music lovers.

That music is indispensable in palace or shack is proved by the order placed with Heintzman & Co., Edmonton, Alta., the past month. This firm had the pleasure of sending a Victrola and a large number of Victor records almost to the Arctic Circle to the order of the Northern Fiscal Co. at House River oil well.

Reed & Robinson, Edmonton, and the Edmonton Drafting & Supply Co., of the same city, have taken on the Brunswick agency and are handling a large number of this make.

ESTABLISHES MANY NEW AGENCIES

**David Bartlestone, President of Lucky 13
Phonograph Co., New York, Tells of Important
Deals Closed—Big Delivery of Cabinets**

In a chat this week with The World David Bartlestone, president of the Lucky 13 Phonograph Co., New York, manufacturer of the Cleartone phonograph, stated that the demand for these instruments is increasing steadily, and that new agencies have been established throughout the country. A number of important deals are now pending whereby the Cleartone phonograph will be given aggressive representation in leading trade centers, and judging from the orders now on hand the factory will be obliged to work to capacity to take care of the demands of its dealers.

Mr. Bartlestone was recently advised by the Saginaw Table & Cabinet Co., Saginaw, Mich., manufacturer of the Cleartone cabinets, that fifteen carloads of the four models of Cleartone phonographs are now ready for delivery, and arrangements have been made for shipping these instruments to all parts of the country. This cabinet company is one of the best-known manufacturers in the country, and numbers among its employes expert workmen who are thoroughly proficient in their respective fields. John Herzog, well known in cabinet circles, was formerly president of the company, and the plant is equipped to turn out cabinets of exceptional quality and attractiveness.

BIG DEMAND FOR RECORD ALBUMS

**Talking Machine Manufacturers Placing Next
Season's Orders Much Earlier Than Usual,
Declares the Boston Book Co., New York**

The Boston Book Co., Inc., manufacturers of record albums, is finding the demands for the fall season to be larger than of any in the past three years. All the larger talking machine companies seem to be placing their season's orders much earlier than usual, and from the size of these orders it is easily seen that the industry is looking for one of the biggest years in the history of the trade.

J. M. Alter, president of the above company, in speaking of the volume of business now under contract with his firm, said: "While it is true we have had to enlarge several times during the past eighteen months the fact that we have constantly installed labor reducing machinery in every addition we have made has placed us in a position where we are able to meet the demands on a very large scale. Then, too, we foresaw the big demands which would be made on paper stock and prepared ourselves for the shortages which have appeared from time to time."

"MAGNET" DECALCOMANIE NAMEPLATES

FOR TALKING MACHINE
CABINETS ETC.

Pamphlets with fac-simile illustrations and prices mailed on request.

SMITH-SCHIFFLIN CO.

126 Liberty Street New York City

FROM THE
DORAN CO.
118 MICHIGAN AVE.
DETROIT

SOLD BY
HURTEAU, WILLIAMS & CO.
MONTREAL — OTTAWA

Kunkel Piano Co.
BALTIMORE

FROM
THE PHONOGRAPH CO.
1240 HURON ROAD (Interlump Road)
PHONES - PROSPECT 2100 - CENT 1406
CLEVELAND

SOLD BY
WALTER D. MOSES & CO.
Oldest Music House in VA and N.C.
RICHMOND, VA.

SOLD BY
J. E. STRATFORD
AUGUSTA, GA.



Otto Heineman Phonograph Supply Co.

INCORPORATED

25 WEST 45th STREET, NEW YORK

FACTORIES, ELYRIA, O.—NEWARK, N. J.
PUTNAM, CONN. SPRINGFIELD, MASS.



CHICAGO

ATLANTA

SEATTLE

CINCINNATI

TORONTO

THE HEINEMAN NEW No. 77 MOTOR

This motor embodies many *new* and *exclusive* features, some of which are shown in the accompanying illustration.

The **HEINEMAN NEW No. 77 MOTOR** is the

leader in its field, and is covered with the iron-clad Heineman guarantee.

This motor is warranted to give positive and lasting satisfaction to the ultimate users.

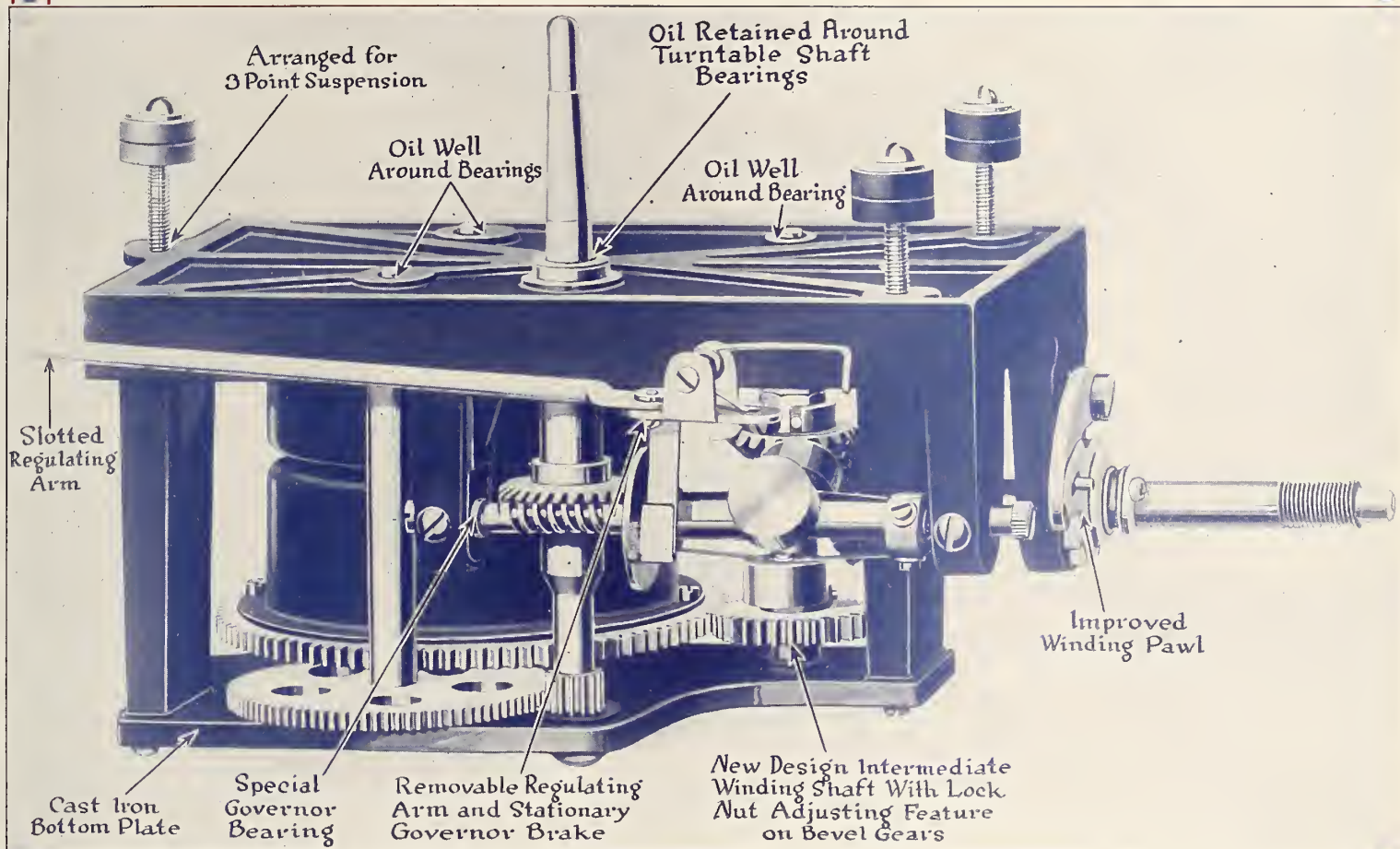

The Heineman New No. 77 Motor

Ask for our new catalogs. They are the recognized authorities of the Trade

Otto Heineman
President



MEISSELBACH



TONE ARMS

MOTORS

SOUND BOXES



TELLS OF EXPERIENCES AT FRONT

Major Noyes Writes C. N. Andrews of His Exciting Time at the War Front—Is Connected With the Motor Cycle Division of U. S. A.

BUFFALO, N. Y., July 4.—“I just returned from the American front, where I had an exciting but very interesting time. I covered all of our front except one small section.”

This is an excerpt of a letter which C. N. Andrews, of W. D. & C. N. Andrews, has just received from his former traveling representative, Major Hal H. Noyes, who is head of a motorcycle division of the American army in France.

“I was on a trip of investigation relating to road and ground conditions over which motorcycles have to operate,” continued Major Noyes. “I had a young second lieutenant named Enos with me. It was his first experience under fire and he was as curious as a village gossip. You know curiosity killed a cat once and while it didn’t get Enos, all I can say he was lucky. Perhaps I’m getting old, but when you are up there where the show is going on one feels like a kid and you do get curious in spite of instructions. You take chances enough in the regular course of events without going out of your way inviting trouble, and I was for playing safety first when possible. We got in one predicament which was warm as h—l while it lasted and it lasted from 12.30 midnight until after 4 in the morning. Some of it was funny and most of it was rather disconcerting, especially when you come out of a sound sleep and realize that big shells are bursting all around you and you don’t know where to find a nice deep dugout; well, that is what happened to us.

“We went to bed in a deserted house in a deserted old town which had been rather badly wrecked by shell fire. We had a pretty good place to lay out our bed rolls and had turned in rather early. Enos and I in one room and a young medical officer in another. As it was rather cold I didn’t undress fully, had removed my boots and coat and had rolled up in my blankets. At 12.30 I heard a h—l of a bang right outside the house and I came out of that sleep right quick. The Hun was giving us a party and he sure did have the range beautifully. They (the shells) came in bunches. You could hear the gun, then the shell coming and the bang when the shell exploded. About then some one sprung a gas alarm and we made a dive for gas masks. Well, I couldn’t find the one I wanted but had another one right handy (and you sure keep them handy), so I got into that. You see we always carry two. I looked around for the doctor and Enos. Both were all right. The doctor was sitting up in bed with a gas mask on and struggling with his breeches. Enos was trying to get on a gas mask, hold his breath and swear all at the same time, and he sure was having a busy time of it. The mask I had on permitted me to talk—his didn’t. I said to him, ‘Well, you desert rat (he is from New Mexico), how do you like war now as far as you have gone? Depends on which end of a gun you’re on, don’t it?’ He could only wave his arms. He was sure game though, and so was my driver. The first thing he did when he woke up was to come to me for any orders, and it was his first experience under fire. There wasn’t anything to do except sit there and hope to heaven one of those fast ones wouldn’t connect with the building we were in.

“Well, they didn’t. There was a lot more to it which I will tell you some other time. After the show was over we found a perfectly good dugout, the best in town right under the building we had been sleeping in. Can you beat it?”

Walter E. Bush, 109 Highland avenue, Jersey City, N. J., has recently been appointed United States buyer for one of the largest import corporations in Australia. He will be glad to hear from manufacturers who are not represented in that market.

RECEIVING ORDERS BY AEROPLANE

I. Davega, Jr., Inc., 125 West 125th street, New York, Victor distributors, report a steady increase in the number of dealers making use of “The House of Service.” A number of orders were recently received by aeroplane. It is the hope of this house that some time in the future they will be able to fill aeroplane orders in like manner and instead of the trucks which they now have a fleet of aeroplanes will rapidly deliver the filled orders.

Randall & Mayo, piano, talking machine and sewing machine dealers in Ticonderoga, N. Y., have fitted up a very attractive room in the rear of their store for the display and sale of Grafnolas and records.

NEW QUARTERS FOR H. MICKELAS

H. Mickelas, manufacturer of demonstration booths and general store interiors, has moved from 164 McKibben street, Brooklyn, to 387-389 South First street, Brooklyn, N. Y. In his new quarters Mr. Mickelas has ample room to take care of the rapid expansion of his business, and the facilities afforded will enable him to double his output in the very near future.

In a chat with The World Mr. Mickelas stated that he has several important deals pending whereby dealers in metropolitan territory will install the Mickelas system of booths. This system has several individual features, which have made a favorable appeal to dealers who are planning to enlarge their store equipment in order to handle holiday trade.

Increased Production and Advertising

Production of Converto Cabinets—for converting small “Victrolas” into beautiful Cabinet Types—has never equaled demand. However, we are succeeding in so greatly increasing facilities for making as to be able to take care of requirements of old customers and a reasonable sale to new dealers.



Patented December 11, 1917

TALKING MACHINE CABINET

With the shortage in cabinet machines and the opportunity offered in selling these cabinets to present owners of small “Victrolas” the Converto is surely a Big Thing for Dealers. Its very rapid sale to date is proof of its success for all who have stocked it.

The time for you to get particulars and prices is NOW.

The C. J. Lundstrom Mfg. Co., Little Falls, N. Y.
Branch Office, Flatiron Bldg., New York City

The Lundstrom “Converto” Cabinet converts the small “Victrola” into a handsome cabinet type, completely enclosing the machine. It takes the place of a stand and provides a dustproof record rack for 60 records. It re-vives interest in records. It helps you meet low-price competition in cabinet machines and gives you a *good profit*. It costs the customer no more than a good stand!



Setting Victrola into Cabinet

Sound Doors Open for Playing

Annie Laurie

Salesmen Wanted

The Compton-Price Co., Coshocton, O., manufacturers of Stradivara phonographs—a quality product throughout—wish to engage salesmen to cover the following territory: Illinois, Michigan, Wisconsin, Iowa-Nebraska, Indiana, Minnesota-North and South Dakota, Missouri-Kansas, Oklahoma-Texas-Arkansas-Louisiana.

The STRADIVARA

Art Phonographe

“KNOWN FOR TONE”

(PATENTED)

appeals to the better class of trade; is fully guaranteed and is so different in tone, artistic cabinets, workmanship and mechanical equipment from the ordinary standard talking machine that it invites favorable comparison. Seven models from \$60 to \$250. Elaborate catalogs, advertising service and sales assistance to dealers who are exclusive in each locality. Applications only of reliable, clean cut and aggressive gentlemen invited who wish to find a permanent and profitable connection. Address all applications to Coshocton, O.



Stradivara Grand. No. 250. \$250.00. 7 Models from \$60.00 to \$250.00



No. 95. List \$95.00. 7 Models from \$60.00 to \$250.00

DEALERS

Write for Exclusive
Agency to
The Manufacturers
The Compton-Price Co.,
Coshocton, O.,
or to
Exclusive Sales Agencies

New York, New Jersey, District of Columbia, Delaware, Maryland, Pennsylvania, Connecticut, Rhode Island, Massachusetts, New Hampshire, Maine, Vermont.

Josiah Partridge & Sons Co.
Furniture Exchange,
46th St. and Lexington Ave.,
New York

Oregon, Washington, Idaho, Montana, Wyoming, Colorado, Utah, California, Arizona, New Mexico, Nevada.

Sallstrom Corporation,
405 Morrison St.,
Portland, Ore.,
or
Sallstrom Corporation,
Southern Division,
1055 Market St.
Furniture Exchange,
San Francisco, Cal.

PRINCESS WATAHWASO IN PEORIA

New Victor Recording Artist Appears at Banquet of State Federation of Musical Clubs and Is Received Enthusiastically

PEORIA, ILL., July 5.—A recent musical event of particular interest was the appearance in this city of Princess Watahwaso, a new Victor artist, who was brought here through the efforts of Miss May N. Cloud, of the educational department of the Putnam-Page Co., local Victor wholesalers. The occasion was the banquet of the State Federation of Musical Clubs.

Princess Watahwaso appeared in native costume in a group of Indian songs and ceremonial dances, and scored a decided triumph. One of the local papers in describing the appearance of the Princess said:

"Princess Watahwaso, a Penobscot Indian, gave the most delightful entertainment of the evening. Dr. Erb, dean of music, of the University of Illinois, in introducing her spoke of the appropriateness of having a true American artist to sing at this occasion—the Princess appeared in native costume of white suede with dangling beads, and her black hair flowing about her shoulders, bound about her forehead with a band of beads.

"The charming and gracious little Indian maid walked away with a large share of the honors, being recalled many times, and was received with great interest and enthusiasm.

"She sang 'By the Waters of Minnetonka,' 'By the Weeping Water,' a characteristic Chipewewa song, 'Aooah,' a Pueblo love song, composed by Thurlow Lieurance, the noted American composer and leading authority on Indian music. In response to insistent encores she gave the 'Wedding Ceremonial Song and Dance' of her native Penobscot tribe.

"She sang with much of that poetically descriptive gesture peculiar to the aborigine. Her voice is a beautiful mezzo soprano, full of charm and richness, with adorable soft fluting inflection in it that enchanted her audience. All these songs have been recorded by the Victor Talking Machine Co., of Camden, N. J., and are sure to be much in demand after the singer's triumph last night.

"The Princess has been 'doing her bit' in this war by singing to the soldiers in various cantonments; taking an active interest in the Red Cross work and all war activities. Her friends feel that she is doing a great work in holding before the Indians the importance of retaining their traditions and in giving these traditions to the whites."

THE HAWTHORNE SYMPHONOLA

LOS ANGELES, CAL., July 1.—The Southern California Hardwood & Mfg. Co., of this city, has achieved pleasing success with its attractive line of Hawthorne Symphonola phonographs, which it introduced some time ago to the Western trade. This company is one of the leading manufacturing concerns in the West, and the fact that it manufactures all of the cabinets for the Hawthorne Symphonola line has enabled it to introduce these products to the dealers with every confidence in their ready sale.

The company recently issued to its trade an artistic booklet showing the three models of the Hawthorne Symphonola, which are in popular demand at the present time. These instruments are designated as models B, A and C; all cabinet models that cannot fail to appeal to the tastes of discriminating music-lovers. The mechanism includes a universal tone arm and a motor that has won country-wide recognition for its many qualities.

DISPLAY THE CHENEY PHONOGRAPH

The Welte-Mignon studios on Fifth avenue at Fifty-third street, New York, have on display a number of models of the Cheney phonograph. The Welte-Mignon studios form a very fitting background for the several handsome Cheney models.

INTERESTED IN MUSIC ADVANCEMENT

M. L. Parker Co., Phonograph Dealers, Take Initiative in Effort to Find Out What the National Bureau for the Advancement of Music Is Doing—Piano Men Might Copy

C. M. Tremaine, director of the National Bureau for the Advancement of Music, received the following very interesting letter from the M. L. Parker Co., Edison phonograph dealers of Davenport, Ia.:

"We are exclusive Edison dealers in Davenport, which has a population of about 70,000 and about that many people to draw from. We have two representative newspapers and a fairly live musical community.

"I have some of your literature before me and want to know more about your plan of procedure in interesting the newspapers in the work. You advocate community singing and other things in your pamphlet.

"After receiving information regarding same if I feel capable of putting the thing over in such a way that the people here will really de-

rive a musical benefit from the work, I am prepared to give a portion of my time to seeing it through.

"Being in the business of music I fully believe that music will help win the war and I want to do my bit to aid the cause in some way if possible."

The letter is particularly interesting inasmuch as the talking machine dealers have not been as yet directly solicited in support of the bureau, and the Parker Co. were impressed rather with what the bureau had done, and was doing, than by any propaganda sent directly to their store. It would seem a very fine thing if a number of piano merchants who have had fully explained to them in person and through letters for a year or more past, just what the bureau is doing and what it stands for, would show an equal willingness to take an interest in the work and to investigate its possibilities. The phonograph and talking machine men know from personal business experiences that the "Music in the Home" idea is not just a slogan, but will bring business in actual practice. It is time for certain piano men to wake up to this fact.

Conservation

REMEMBER, in ordering, that we, as all merchants, are working on a war-time basis.

Conservation of labor is essential. Plan to eliminate as much clerical work as possible and thus help us to maintain our service.

If you must know what we are shipping, send duplicate copies of your order with the request that we return one copy with the numbers filled crossed off.

C. BRUNO & SON, Inc.

(Established 1834)

Wholesale Exclusively

351-353 Fourth Avenue

NEW YORK

W. S. S.

Just forget that you get \$5 Jan. 1st, 1923, for \$4.18 invested now.

But DON'T FORGET that your country needs that \$4.18 now, and it's up to you to help.

Buy a W. S. S. today.

Do it again next Monday, and every Monday up to the limit.

CRYSTAL EDGE MICA DIAPHRAGMS

M
I
C
A

Let us send you samples *today* of our diaphragms and you will readily understand why the best talking machines are equipped with *Crystal Edge Mica* diaphragms exclusively.

We use only the very finest selected mica, the best diaphragm material in the world.

PHONOGRAPH APPLIANCE CO., 109 West Broadway, NEW YORK

SLIGHT DECLINE IN MACHINE DEMAND IN CINCINNATI

Record Business, However, Grows to Embarrassment of Dealers—P. H. Oelman New District Manager for Phonograph Co.—Introducing OkeH Records—Comments on Conditions

CINCINNATI, O., July 5.—A rather sharp decline in the demand for machines appears to have struck dealers in all lines of talking machines during the latter end of June and the first few days of July. The situation is one that the merchants are unable to account for. The record business is inclined to be satisfactory, but the merchants are finding difficulty in getting their needs in the way of old-time favorites.

P. H. Oelman, former traveling representative of the Phonograph Co. in the Middle West, running out from the Cincinnati headquarters, has been made the manager of this district. He takes the place of A. O. Peterson, who opened the Cincinnati branch and now retires from business, going to a property on the Puget Sound which he has been developing several years. Mr. Oelman's place on the road was taken by A. R. Holbrook, formerly with the John Roberts Co., Utica, N. Y.

From indications C. W. Neumeister of the Cincinnati office of the Otto Heineman Phonograph Supply Co., will have no difficulty in securing representatives to handle the OkeH records, samples of which were received here Monday. He passed around word to those who might be interested in this new phase of Heineman industry and was immediately deluged with demands for the goods. It will be a week or more before he will be able to do anything for the merchants on a large scale.

Buy early is going to be the motto of Manager Dittrich, of the Victor department of the Rudolph Wurlitzer Co., this summer. His comment on the past month's developments follows:

"We are very glad to say that while the shortage of machines and records is just as bad as ever, transportation facilities have improved to such an extent that talking machine dealers and distributors look for better times to come. Increased production is sure to follow better transportation conditions.

"Talking machine trade was fair during the last thirty days, although records were in far greater demand relatively than Victrolas. This is only natural, as a record purchase carries with it no future obligations as does a machine purchase.

"There is a well defined movement among dealers to try and educate the public to make their purchases during the summer and early fall rather than wait until the last minute before they buy their Victrolas. Every patriotic reason can be advanced to prove the necessity of early buying, while the interest of the purchaser would point to the same direction."

June business in the Vocalion department of the local Aeolian Store showed a nice increase. The new increase in price does not seem to affect the sale of the instruments in the least. The public is becoming accustomed to advanced prices and really expects them.

The new Vocalion records recently announced are experiencing a good demand and the approbation of all who hear them.

Chas. Spence, for three years in the Vocalion repair department, left the Aeolian service recently to sojourn with his parents for a few days before joining the ranks of the Pershing

Crusaders "over there." His departure means another star in the Aeolian service flag.

There continues to be a steady call for the Vitonola, made by the Vitonola Talking Machine Co., of Chicago, Ill., which is represented in this city by the E. Kleeman Co., the Dines Furniture Co. and the Sample Furniture Co.

NEW VICTOR NUMERICAL CATALOG

All Records Up to and Including May, 1918, Supplement, Found in New Volume

The Victor Talking Machine Co. has just issued a new numerical list of Victor records, embracing all records up to and including the May supplement. There is also provided on a separate sheet a list of nearly 100 records withdrawn from the May numerical catalog. It takes 248 large pages to list all the records. The catalog is heavily bound, and bears on the inside front cover some excellent suggestions on how to keep track of record stock.

INCORPORATED

The Bradbury-Santamarina Co., New York, has been incorporated with capital stock of \$30,000 to manufacture and deal in phonograph records and school supplies. The incorporators are R. Bradbury, F. L. Maguire and J. P. Santamarina.

Robt. Nietzel has taken over the management of the Victrola Shop in Muscatine, Ia. He is well and favorably known.

MORE PAY FOR EDISON MEN

Eight-Hour Day Will Mean Wage Increase of \$500,000 Per Year for Edison Employees

The Thomas A. Edison Affiliated Interests in Orange, N. J., announced recently to their 8,000 employes that, starting on Monday, they would get an eight-hour day with time and one-half for overtime, which means a wage increase of approximately \$500,000. The announcement was made at a noonday patriotic demonstration by George E. Clark, special assistant to Charles Edison, chairman of the board of directors of the Edison interests, and was greeted with cheers by the workers. They formerly worked ten hours a day.

That no dividend had been declared by the Edison interests since 1907 was announced in a statement prepared by Charles Edison, at the request of his father, Thomas A. Edison, honorary president of the Naval Consulting Board. Since that time Mr. Edison has turned back every dollar into the business to improve working conditions, to make up the loss of \$3,000,000 in the fire of 1914, and to protect the industries against a shortage of material which would have thrown thousands out of work.

DELPHÉON IN PERTH AMBOY, N. J.

New Store Opens at 185 Smith Street, With C. T. Dixon in Charge

J. D. Manton, president of the Delphéon Sales Co., distributors for the products of the Delphéon Co. in this territory, announced recently that the company would open on July 1 a new store at 185 Smith street, Perth Amboy, N. J. In addition to handling the complete Delphéon line there will also be featured at this store the Bagatelle phonograph, together with music rolls, sheet music, art pottery and floor lamps. Mr. Manton is now consummating arrangements whereby there will also be handled in this establishment a line of pianos and player-pianos.

C. T. Dixon, who has been a member of the sales force of the Delphéon Sales Co.'s store at 25 Church street, will be manager of the new store. In view of the fact that it will be located on the leading street of Perth Amboy, and will be a quality establishment in every detail, the success of the new store is practically assured.

A Victrola was recently presented to the soldiers at Fort Smallwood, Md., by the Daughters of Liberty.



Summer time—the play time—nothing sounds so sweet as a Schubert out of doors.

On the porch, in the cottage or at the camp.

Dealers do well to remember that the

SCHUBERT PHONOGRAPH

is being used more and more to furnish afternoon as well as evening entertainment—outdoors as well as in the home.

This means a steady source of income for Schubert dealers. Are you one of them?

Six Models, \$60 Up

The BELL TALKING MACHINE CORPORATION

Offices and Show Rooms:
44 West 37th Street, New York

Factory:
85 Southern Boulevard, Bronx, New York

Export Department, 498-504 Broadway, New York, N. Y., E. U. A.

Smith-Woodward Piano Co., 1018 Capitol Ave., Houston, Tex., Local Distributor



Featuring the Musical Possibilities of the Talking Machine

By William Braid White

[Note.—This is the seventeenth in a series of articles on the general subject of the musical possibilities of the talking machine. The aim of the series is to develop these possibilities from all angles, thus opening up fields for sales expansion oftentimes neglected wholly or in part.—Editor.]

FREDERIC FRANCOIS CHOPIN

Among the lovers of piano music and the talking machine records representing that instrument, no compositions transferred to the disc are greater favorites than those of Frederic Chopin.

It is a fact, perhaps as remarkable as any other that can be gleaned from the history of music, that the annual American sales of the compositions of Chopin, in sheet music form only, exceed the total sales of his music during his entire lifetime. Whatever other composer a pianist may or may not like, whatever man's work he may like especially, or dislike pointedly, it is quite certain that he will like Chopin. Nor is it less true that every pianist thinks he can play Chopin's music extremely well; although it is equally true that of all current musical delusions this one is the most absurd.

"Poet of the Piano"

Men have differed about most things, but there has been no quarrel for fifty years with the belief that Frederic Chopin is pre-eminently the poet of the piano. Although he has been under the sod these seventy years, musicians and music-lovers still find in his compositions unsurpassed beauties and richness. The piano is a queer instrument. Precious few, of all the men who year by year have ground out melodies, with and for it, have come anywhere penetrating its secret. One of the qualities of the piano which makes it most fascinating—that "liveness" of tone, neither stringy, nor twangy, but both at once, with a dash of organ pipe and a suspicion of tenor voice thrown in—is also the secret of its difficulty for the man or woman who would master it. As Paderewski once said, "everybody plays the piano—and nobody plays it."

Just here, too, is one reason why piano records were not always as good as they are getting to be. On this point I had a good deal to say a few months ago in these columns.

Chopin and Tone

But Chopin did know his piano. Not only was he a pianist himself of exquisite subtlety and mastery, with a tone production that sang like a violin, that was sustained without blurring and powerful without banging, that whispered like a dove or spoke with the majesty of the diapason, but he worked out his ideas of piano tone into his music in so thorough and masterful a shape that the two run parallel throughout his entire series of works. In a word, you cannot play Chopin to make him sound like Chopin, unless you can make the piano sing while you are playing it. If you cannot draw from the piano a tone that lives and sings, you cannot play Chopin, though you read him backwards and forwards with equal ease. You may play his notes; but that is another story.

"Chopinists"

Conversely, that is why all the great pianists, the men who really make a piano sound like a voice and not like a thump, men like Paderewski, Josef Hofmann, de Pachmann, and such fellows, are all avowed Chopinists. You know, Huneker, calls de Pachmann the "chopinzee"; which is not a bad nickname in its way, seeing that the little Russian, now retired from the bright lights of the concert stage, is at once a divine revealer of Chopinesque beauties and a veritable chimpanzee of impish temperament.

Now you, who are anxious to see the piano record come into its own, will not be sorry to get a better acquaintance with the music that

is piano music par excellence. When you consider, too, that among the comparatively few piano records as yet on the market there are already more than two dozen Chopin selections, and that all the greatest among the pianists who have recorded their art have chosen Chopin numbers in about one-half of all instances, you will realize that there must be reason for all this. Mainly this reason is as I have stated above. In any case, you cannot do better than get a line on all the Chopin records. To do this you must first get a line on Chopin, the man and his music.

Biographical

Frederic Francois Chopin was born in the year 1810 at Zelazowa-Wola, a small village near Warsaw, Poland, of a French father and a Polish mother. Discovering extraordinary talents for the piano, he studied under good masters, and in the year 1830, after an European tour, he settled in Paris and here remained until his death in 1849, teaching, playing and composing. He was known to only a limited number of artists and connoisseurs. Liszt and Schumann loved and esteemed him and their appreciation was of immense value. He was physically frail and his early death was from tuberculosis. His curious affair with George Sand was the only serious one of his career, and on her part was almost purely maternal. He never married, but was till his death the favorite of all the musical young ladies of Paris. His compositions are nearly all dedicated to one or another of the famous Parisian or Polish music-loving beauties of the day.

Such are the brief outlines of a life externally uneventful, internally most stormy and musically fruitful. Chopin's piano music made the piano a poet's instrument, drew its real voices to life and built up an entirely new and wonderful school of playing. To this day, as was remarked before, the test of a pianist's ability is found in his Chopin playing.

Chopin's contributions to the literature of the piano are not extraordinarily numerous, but they are most precious. He invented new forms, developed old ones and built up a tonal idea for the piano wholly new and original; an ideal which has led every piano maker and every

player of the piano ever since, onwards to higher and higher achievements.

Etudes

Chopin began his serious career with the composition of a book of studies, intended for pupils in higher branches of piano playing, but in fact, no more or less than little poems of passion and beauty, each a gem in itself; although each likewise includes some special technical problem. There were twelve of these Etudes and they have become world-famous. Every pianist must play them and every pianist delights in playing them. They were followed somewhat later by another set of twelve, which are equally fine and equally well known.

Records of these Etudes are fairly numerous. One of the loveliest is contributed by Wilhelm Bachaus. It is the study in double notes Opus 25, No. 6, and can only be compared, in its shimmering beauty and softened glory, to the gleam of moonlight on water. It is hugely difficult, as all passages in double notes must be when set to be played at once very rapidly and very softly.

One of the special Chopin favorites, known to everybody, is the so-called Black Key Study, Op. 10, No. 5, records of which have been made by the wizard of all Chopin players, de Pachmann. The little Russian has his peculiarities and there are those who object to his habit of talking to his audiences, to his grimacing and to his impossibly peculiar mannerisms; but those are matters of the past now, anyhow, and no one can deny his transcendent ability to play beautifully the beautiful music of Chopin. This black key study is so-called, because the key in which it is written necessitates the employment of more black than white keys. But the study itself is so brilliant, so glittering, and yet so wholly lovely, without the slightest suspicion of roughness or crudity, that by itself, without any question of its technical difficulties, it is a favorite deservedly amongst all who love Chopin's music.

Nocturnes

The Nocturnes of Chopin are love-poems every one. De Pachmann has recorded one of the loveliest, in G major, which is as warm and

(Continued on page 56)

7th Floor

229 Fulton Street

Clifford A. Wolf

MANUFACTURER OF

Diamond and Sapphire
Phonograph Points

New York City

Phone, 1678 Cortland

THE MUSICAL POSSIBILITIES OF THE TALKING MACHINE

(Continued from page 55)

gentle as a summer afternoon, while Paderewski has tried his hand at a record of the famous Nocturne in F sharp major, and Xaver Scharwenka has played the Fantaisie Impromptu, which is only a lighter and more delicate edition of such a Nocturne as the one in E flat.

Valses

The Valses of Chopin were not composed to be danced to, but are rather spiritual interpretations of the dance, or interpretations of the spirit of the dance, as you will. All the great pianists have tried their hands at them, and we have quite a nice lot of records. One of the very best is by Andre Benoist, of the Valse in A flat, which Godowsky has also recorded. Another famous Valse, in G flat, has been recorded by Godowsky, who can do incredible things with his fingers, but who is not the ideal Chopinist, such as de Pachmann always is.

Polonaises

The famous Polonaises of Chopin are represented at present in records only by the Military Polonaise so-called, although there are others, such as the one in C sharp minor, which are even better, or the great one in A flat, which might be called rightly the Heroic Polonaise. Still, the Military Polonaise is very fine. It is recorded by Paderewski and also by Josef Hofmann.

A Polonaise is a typical Polish dance measure. Rather, in fact, it is a music composed for one of those semi-barbaric, wholly magnificent, processionals in which the Polish nobility used to show their splendor and their grace at those famous revelries in their castles. It was a dance and a procession in one, a sort of modernized Theoria, a winding chain of chivalry and beauty, in which knight and lady, paired in glittering couples, wended their way, to music and laughter, through the halls and grounds of some Polish noble's ancestral castle. It is a semi-military measure, and the crash of arms, the gallop of horses and the shouts of the army are always to be heard in it. The Military Polonaise can only be played rightly by a great Chopinist. Two such have recorded it.

Ballades

The Ballades of Chopin, four in number, are musical settings of heroic Polish legends. The Ballad in A flat, which has been recorded by the inimitable de Pachmann, is the one Ballade of the lot which he would do perfectly. It is concerned with a legend of the magic Lake Switez and is a tale of a lovely princess, a faithless lover, and the terrible fate which came upon him through his lack of knightly chivalry towards his

lady. It is a lovely number from end to end.

Scherzos

The greatest of all Chopin's compositions, for force and fire, are his Scherzos. The word Scherzo means "jest," but these are bitter jests indeed. The one recorded by Arthur Friedheim, a true giant of piano playing, is the most moving, the most powerful, the wildest of all, a torrent of unrestrained emotion which seems to carry away the piano with it in an ocean of tonal grandeur. It is the overflowing of an ardent spirit chained to a frail body, crying out in tone his love for his bleeding native land, his Poland, which he could not express in deeds of battle. Chopin saw his Poland torn and bleeding;

we of this day shall see her once more free, strong, happy and united.

This Polish nobility of thought, this deathless patriotism, this national feeling that is everywhere in his music, in every bar of music he ever wrote, must be appreciated by all who would love Chopin aright. No music lover who has once been inducted into this love, will ever lose it. In these days, when we fight to make a world free, we can appreciate Chopin better than he has ever been appreciated before.

A last word: The talking machine records by great artists have for the playing of Chopin an unique value. They record perfectly the most perfect style of interpretation. It is style that most of those who undertake Chopin least can compass.

Sell piano records; and remember Chopin.

NEW MANAGER FOR GRAFONOLA SHOP, INDIANAPOLIS

J. L. Peters, Veteran of the Trade, Takes Charge of Columbia Co. Retail Store in That City—More Machines for City Recreation Centers—Pleasing Business Reports

INDIANAPOLIS, IND., July 5.—History repeated itself in more ways than one when J. L. Peters, formerly of the Wagner Music Co. and for years with the old Wulschner-Stewart Music Co., was appointed manager of the Grafonola Shop at 44 North Pennsylvania street by the Columbia Graphophone Co.

"I regard it as rather a coincidence," said Mr. Peters to a representative of The World, "that twenty-seven years ago I was in the music business in this same room and sold the Columbia talking machine—the same machine I am selling now."

Mr. Peters started out in the music business with the Wulschner music store, which was then at 42 and 44 North Pennsylvania street. The Wulschner's handled the Columbia talking machine. Mr. Peters recalled that in 1891 he had displayed the first two Edison talking machines in Indianapolis. And yet it must not be inferred that Mr. Peters is an old man—far from it!

The appointment of Mr. Peters is an outgrowth of the recent separation of the wholesale and retail branches of the Columbia Co. in Indianapolis. Ben L. Brown, the local manager of both branches, is getting things in nice shape at the wholesale department at 209-217 West Washington street, where he has his offices.

Dwight S. Ritter, city purchasing agent of Indianapolis, has bought for the recreation department three Columbia talking machines. Last year the city used one talking machine in one of the recreation centers and it was decided to increase the number this year. The

machines will supply music for physical exercise drills, folk dancing and entertainment.

Talking machine dealers say business in Indianapolis is holding up very well, the records showing in a number of instances better conditions than existed at this time a year ago.

K. Wesley Smith, of the staff of the Indianapolis News, and for several years local correspondent for the Talking Machine World and the Music Trade Review, has been "called to the colors." With five hundred other Indianapolis young men he left recently for Camp Sherman at Chillicothe, O.

NEW PARAMOUNT JOBBERS

Important Announcement Made by the New York Recording Laboratories, Inc.

PORT WASHINGTON, WIS., July 9.—The New York Record Laboratories, Inc., manufacturers of the Paramount records, with general offices in this city, have found the demand for Paramount records increasing so rapidly that they have been compelled to add several new presses to the already large equipment at the plant at Grafton, Wis., located a few miles from Port Washington. Manager M. A. Supper announces that arrangements have just been made with the Baldwin & Miller Co., Indianapolis; J. B. Orth & Co., Republic Bldg., Chicago, and the Ricks Furniture Co., Dallas, Tex., to act as jobbers for the Paramount product. All three concerns will carry ample stocks of the Paramount records and will push the business in their respective territories very vigorously.

Efficient Record Service

ECLIPSE

THE accompanying illustration shows one of the numerous efficiency systems we have installed in order to make Eclipse Victor second to none in the matter of giving prompt attention to orders.



Loading Truck Right on Stock Floor

ECLIPSE MUSICAL COMPANY
CLEVELAND OHIO

Records For

ZIG-ZAG

(Lateral Cut, and all Other Types)

Phonographs

Millions of machines—perhaps 75% of all the machines in use play only the Zig-Zag types of records.

Emerson Records are the only discs which can be used on all prevailing makes of machines without attachment.

This feature is of the greatest importance to the dealer in Phonograph records. With the Emerson product your sale of records is universal—Your market includes every owner of a phonograph, no matter what make.

Combine with this exclusive Emerson Record selling point their popular price and you have an article which completely eliminates competition.

Emerson Phonograph Company INC.
 3 West 35th Street New York City

- IF HE CAN FIGHT LIKE HE CAN LOVE,
GOOD NIGHT GERMANY. Patriotic
Solo, Orchestra Accompaniment,
Eddie Nelson
- 940 IF YOU'RE CRAZY ABOUT THE
WOMEN You're Not Crazy at All. Bari-
tone Solo, Orchestra Accompaniment,
Henry Lewis
- GOD BE WITH OUR BOYS TONIGHT.
Tenor Solo, Orchestra Accompaniment,
Frank Woods
- 939 SOUTHERN MEDLEYS. Vocal Quartet,
Liberty Quartet
- THREE WONDERFUL LETTERS FROM
HOME. Tenor Solo, Orchestra Accom-
paniment..... Frank Woods
- 942 A SOLDIER'S ROSARY. Tenor Solo, Or-
chestra Accompaniment..... Frank Woods
- I HATE TO LOSE YOU. Fox Trot,
Emerson Military Band
- 938 THERE'LL BE A HOT TIME FOR THE
OLD MEN While the Young Men Are
Away. One Step..... Emerson Military Band

Some up-to-the-
minute Hits from
the Emerson Pop-
ular Catalogue



SEND THIS COUPON AND GET THE FULL DETAILS

The Emerson Phonograph Company
 3 West 35th Street, New York

T.M.W.

Gentlemen:—
 Kindly send me full details about the Emerson 65c Records.

Name.....

Address.....

City.....



How many folks in your town go on vacations? Count 'em—then sell every one a Grafonola.

**Columbia Graphophone Co.
NEW YORK**

GETTING GOODS STILL THE BIG PROBLEM IN MILWAUKEE

Although Stocks Generally Are Larger the Demand Increases Out of Proportion—The Machines and Records That Are Popular—Association of Music Industries Meets—News of the Month

MILWAUKEE, Wis., July 6.—An unprecedented demand for records, resulting from the large sale of talking machines during the last six or eight months, is the distinct feature of business in Milwaukee at this time. Dealers find it impossible to fill more than a part of requirements, although their stocks are larger than ever before. However, the demand is such that goods are moving so rapidly that even the large stocks do not bring relief. The restriction of catalogs which makes possible a greatly increased production of individual records, has not improved the situation, and no matter how hard dealers try, they do not seem to find it possible to keep stocks up to the needed point.

So far as the supply of machines is concerned, the situation likewise is unfavorable. The retail trade is in a veritable scramble to cover requirements, not only for current sale, but to build up stocks to tide themselves over the fall and holiday period.

"We never have been so hard pressed for goods as now," said Harry A. Goldsmith, secretary of the Badger Talking Machine Co., Victor wholesaler. "This is a most unusual situation, for ordinarily the requirements of the retail trade during the June-July period are only moderate. However, stocks have been short for such a long time and the demand has grown so rapidly that the new goods we are able to obtain are little more than a drop in the bucket, figuratively speaking."

"The New Edison seems to have taken the people of the Northwest by storm, judging from the great demands upon us by our dealers," said a member of the Edison Shop, Edison jobber. "Fortunately we are able to keep fairly well supplied, but orders continue to increase in such volume that we are almost certain to be confronted by a shortage before another two months are over."

The Edison interests operate a large cabinet plant in central Wisconsin, which is an especially desirable arrangement and obviates many delays in furnishing dealers of the territory with goods. The plant is in the heart of the lumber country and is therefore favorably situated with regard to raw materials. Yet the big factory is behind on its orders.

Charles J. Orth, state distributor of the Puritan, is a jobber who is exceptionally well situated in the matter of obtaining adequate stocks, for the Puritan factories are located not far from Milwaukee and while distributors all over the country are in keen competition for goods, the nearness of the Orth headquarters to the manufacturer proves a distinct advantage.

Thomas I. Kidd, general manager of the local branch of the Brunswick-Balke-Collender Co., says business never has been so active as at this time, not even during the best holiday season since the Brunswick phonograph first was introduced here. The big demand, which creates the danger of a shortage, has made it necessary for Mr. Kidd to use an extra amount of care and discrimination in the selection of new dealers from the list of applicants. Brunswick goods are coming through in fair volume, but the requirements of dealers make it extremely difficult to maintain stocks.

A. G. Kunde, wholesaler and retailer of the Columbia, reports that while the orders for machines are unusually broad, the demand for records is still greater and he finds it almost impossible to cope with requirements. Columbia dealers are taking Mr. Kunde's "tip" to anticipate their wants for the remainder of the year, and they are rushing to get "under cover" without delay.

The Pathéphone improves its position among talking machines in the Milwaukee market every day. This territory is handled direct by the Chicago branch, and considering the big demand and relative small supplies available, local dealers are very well taken care of. Like other merchants, however, they could use a great many more machines and records than can be allotted to them under existing conditions.

The Starr phonograph is gaining more and more prestige in Wisconsin territory under the vigorous representation given by the Hoeffler Mfg. Co. Adolph Hoeffler is devoting much of his personal attention to promoting Starr sales and his unusually wide acquaintance in the territory comes in good stead.

Yahr & Lange, Wisconsin distributors of the Sonora, expressed the desire to have once again as many machines on hand. No matter how hard the firm tries to keep its stocks adequate, its growing list of dealers is taking machines

away faster than they come in. Among the dealers recently appointed is Julius Koepke, White-water, Wis. The eight Sonora dealers in Milwaukee city and county are demanding so much stock that it is likely that this list will be restricted to the present occupants for some time to come.

The Badger Talking Machine Shop, Victor retailer, continues to be the scene of exceptional activity. Manager Richard H. Zinke says that in his long experience as a Victor dealer he has never been "up against" conditions now prevailing. "This scramble for goods to fill the hungry maw of the public is enough to keep one awake nights," said Mr. Zinke.

Miss Helen Gunnis, manager of the Music Shop, representing the Starr and Columbia, is making arrangements for further enlargement of the store, which was established less than eight months ago and in this short time has become one of the busiest talking machine shops in Milwaukee. Miss Gunnis is the only woman talking machine dealer in this city and one of the few successful ones throughout the country. Miss Gunnis recently made a trip to New York to attend the National Music Show and extended her reputation as a soloist of note by accepting an assignment to sing in the Universal Music Booth every evening. While in the East, Miss Gunnis also did some recording for the Aeolian and Columbia records. She also visited the Columbia factories at Bridgeport and on her way home stopped off at Richmond, Ind., to inspect the Starr plant. Incidentally, she exercised her usual foresight and provided against a shortage of goods during the coming fall and holiday seasons.

Encouraging reports as to the future of the musical instrument business were brought from the New York conventions and presented to the Milwaukee Association of Music Industries at its monthly meeting on June 20. Paul F. Net-zow was official delegate. Edmund Gram, retiring national president, and C. L. Dennis, the new national secretary, are active in the local association and also contributed much interesting information. At this meeting resolutions on the death of George H. Eichholz, the widely known Edison and Victor dealer of Milwaukee, who died May 30, were adopted. The committee on resolutions consisted of three talking machine men, Charles J. Orth, L. C. Parker of Gimbel Bros., and Oscar C. Schefft, of Schefft's Victrola Shop.

Gustav Kleeman, a traveling representative of Charles J. Orth, 504 Grand avenue, distributor of the Puritan in Wisconsin and upper Michigan, has been appointed a member of the Milwaukee Board of Motion Picture Censors, created by the mayor of Milwaukee to keep the "movie" houses free from unsavory films.

H. J. SMITH—Jewel Manufacturer

MANUFACTURER OF—Phonograph Diamond and Sapphire Reproducing Points—Recording Laboratory Jewels—Jewel Bearings for Electrical Instruments—Rough Diamond—Diamond Powder—Experimental Work.

Telephone 2896 Market
833 BROAD STREET NEWARK, N. J.

PERSONAL SERVICE

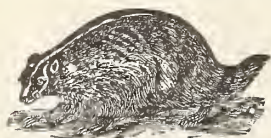

The members of our Company are always available and will gladly see you personally or write you at any time we can possibly serve you.

Why not communicate at once with us?

BADGER TALKING-MACHINE CO. 135 Second Street
MILWAUKEE, WIS.
VICTOR DISTRIBUTORS

"AT HOME" IN ITS NEW QUARTERS

Silas E. Pearsall Co. Greeting Its Friends at 10 East Thirty-ninth Street, New York—Efficiency and Co-operation the Company's Aim

The Silas E. Pearsall Co., Victor distributor, is now established in its new quarters at 10 East Thirty-ninth street, New York, and many dealers in local territory have visited the company's new home in order to acquaint themselves with the service facilities that are placed at the disposal of General Manager Green and his efficient sales staff.

In its present quarters the Silas E. Pearsall Co. is in a splendid position to render maximum co-operation and efficiency to the dealers in metropolitan territory, as the building at 10 East Thirty-ninth street is ideally located from a transportation standpoint. This is an important factor, of course, in the delivery of merchandise at this particular time, and, although it has only occupied its new home for a few weeks, the company has already received expressions of approval from its dealers regarding the service rendered. Every division of the company's forces is leaving nothing undone to cooperate with the dealers, and this spirit of harmony and efficiency is reflected in the popularity of the Pearsall organization in local talking machine trade circles.

CHEERING REPORT OF BUSINESS

KANSAS CITY, Mo., July 9.—O. D. Standke, manager of the Victrola department at Geo. B. Peck Dry Goods Co., reports an unusually good business for the month of June. There seems to be a greater demand for the higher-priced Victrolas.

Mr. Standke also reports that, judging from the large down payments and amount of cash business obtained, money seems to be more plentiful than ever. Record sales are also holding up exceptionally well with a particular demand for patriotic numbers.

Mr. Standke spent several days down on the farm harvesting during the early days, and worrying the fish towards evening. A five-pound bass was his best catch, which he succeeded in landing after a fifteen-minute tussle. He returned to his desk greatly benefited by his trip.

J. H. Hassel, salesman for Geo. B. Peck Victrola department, is spending his vacation somewhere in the Ozarks.

EMBARGO ON GRAPHITE CONTINUED

No More of That Material May Be Imported During 1918—Sufficient Supplies on Hand

The restriction upon the import of plumbago, or graphite, has been extended by the War Trade Board to be effective for the entire calendar year of 1918. The original restriction was made absolute until July 1, with the understanding that a quantity not to exceed 5,000 long tons could be imported for the remainder of the year, provided stocks in this country proved inadequate to meet the requirements. It is declared, however, that investigation has shown present stocks, together with home production, will suffice to meet home requirements until well into 1919. Supplies of graphite are particularly interesting to the talking machine trade, owing to the fact that that material is used exclusively for the lubrication of springs and talking machine motors. Graphite is also used by player-piano manufacturers for lubricating the slides of motors and other wooden surfaces where friction occurs.

BOOKED SUBSTANTIAL ORDERS

R. J. Jamieson, Sales Manager of the Fischer Co., Books Big Pathé Orders—Enthusiastic Over Business Possibilities for the Fall

CLEVELAND, O., July 8.—Ralph J. Jamieson, sales manager of the Fischer Co., of this city, Pathé distributors, returned recently from a very successful three weeks' trip, which was marked by the receipt of unusually large orders for Pathé-phones and Pathé discs. On this trip Mr. Jamieson closed an order with one well-known dealer that called for one of the largest merchandise totals that has ever been received by a representative of any jobber in this territory.

Mr. Jamieson is enthusiastic regarding the possibilities of developing Pathé business in this territory, and states that the Pathé dealers in this section of the country are making plans for a record-breaking fall trade. His keen admiration of the Pathé line and his confidence in its sales merits has enabled Mr. Jamieson to render invaluable co-operation to Pathé representatives. He has made an exhaustive study of the retailing of Pathé-phones and Pathé records, and his success may be attributed in a large measure to his intimate popularity with the dealers' problems.

DONALD MARTIN JOINS U. S. ARMY

Donald Martin has resigned his position as Edison supervisor for the Dominion of Canada, his resignation taking effect July 1. Mr. Martin relinquished this important post in order that he might enter the military service of the United States. At this writing no successor to Mr. Martin has been chosen.

INCREASE YOUR SALES
Mr. Edison Dealer, with the
KENT Attachment
and Sound Box

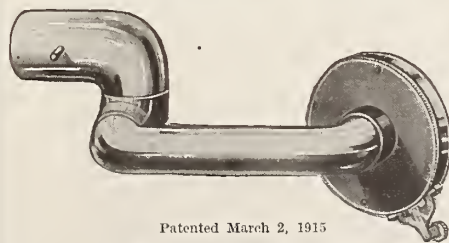

Patented March 2, 1915
SIMPLE AND ACCURATE
Made by manufacturers who have specialized in Edison attachments for years.
SEND FOR ONE TODAY
Most Edison jobbers handle our products. If yours does not send direct.
F. C. KENT & CO.
Manufacturer of Phonograph Accessories
COR. MULBERRY AND CHESTNUT STS., NEWARK, N. J.

Automatic RECORD CONTAINER
PATENTS ALLOWED



Style 5H for Victor IX

Capacity 100 records, designed especially for use with Victor IX. Of special interest to Victor dealers. Same style cabinet without the moulding around top designed for Columbia No. 50, Aeolian and other portable machines.

A Flexible File

—Expands Outside the Cabinet

No weight of records to handle
No broken or misplaced records
100% increased capacity
Every record accessible
Opens Automatically
Files all records
Sells on sight

These cabinets combine business sense with parlor style. A complete modern filing system adapted to home use. An efficient ornament to parlor or library.

Automatic Carrying Cases for Salesmen and Repairmen are ideal—constructed on the same principle as our Record Containers. Every dealer and jobber should equip his salesmen with them to increase their efficiency and multiply record sales.



MAIL THIS COUPON TODAY
Manufacturers: Write for shop-rights under our patents

AUTOMATIC CONTAINER COMPANY
209 So. State St. Chicago

AUTOMATIC CONTAINER CO.
209 So. State St., Chicago
Send me your catalog.

T.M.W.

"Globe" TRANSFER NAME PLATES



STYLE 1



STYLE 2



STYLE 3



STYLE 4



STYLE 5

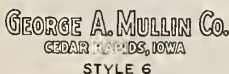

STYLE 6



STYLE 7

CUTS ARE HALF SIZE

Can be easily and quickly applied on

TALKING MACHINES, PIANOS, TYPEWRITERS, SEWING MACHINES, FURNITURE, ETC.

You can order any of the designs illustrated, Style 1 to 7, with your copy, as follows:

- 250—\$16.00
- 500—\$20.00
- 1000—\$27.50
- 2000—\$40.00
- 3000—\$50.00
- 5000—\$65.00

Complete transferring outfit included with every order.

Write for folder "You Need Decalcomanie In Your Business."

Globe Decalcomanie Co.

74 MONTGOMERY ST. JERSEY CITY, N. J.

The most wonderful Talking Machine of the present age at the price
An Instrument of Supreme Value, Tone and Quality

Cleartone

SPEAKS FOR ITSELF



No. 100—\$100

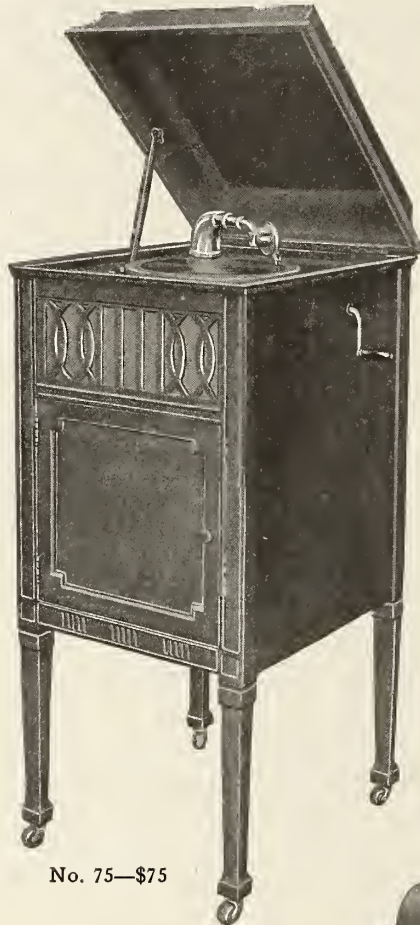

No. 75—\$75

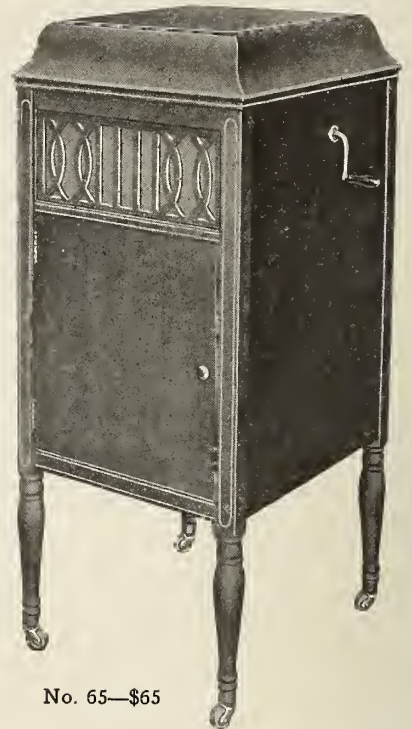

No. 65—\$65

The *Cleartone* has become very popular because of its quality, splendid value and the advertising and sales campaign that now stands in back of it. **Dealers!** Watch us grow—write for our agency and grow with us.

SUNDRY DEPARTMENT

MOTORS—No. 01, 8-in. turntable, single spring, \$1.25; same motor with 10-in. turntable, \$1.40. No. 1, 10-in. turntable, double spring, plays two 10-in. records, \$2.95. No. 6, 10-in. turntable, double spring, plays three 10-in. records, \$3.50; same motor with 12-in. turntable, \$3.85. No. 8, 12-in. turntable, cast-iron frame, double spring, plays three 10-in. records, \$4.85. No. 9, 12-in. turntable, cast-iron frame, bevel gear wind, double spring, plays three 10-in. records, \$5.85. No. 10, 12-in. turntable, cast-iron frame, bevel gear wind, double springs, plays four 10-in. records, \$6.85. No. 11, 12-in. turntable, cast-iron frame, bevel gear wind, double spring, plays seven 10-in. records, \$8.50.

TONE ARMS AND REPRODUCERS—No. 1, \$1.00; No. 2, plays all records, \$1.25; No. 4, \$2.65; No. 6, \$2.25; No. 7, \$2.25; No. 8, \$2.25; No. 9, \$2.25. (Play all records.)

MAIN SPRINGS—No. 00— $\frac{3}{4}$ -in., 23 gauge, 9-6 ft., 29c. each, 100 lots, 25c. each; No. 01, 1-in., 23 gauge, 7 ft., 25c. each, 100 lots, 20c. each; No. 0, $\frac{3}{4}$ -in., 20 gauge, 8-6 ft., 25c. each, 100 lots, 21c. each; No. 1, $\frac{3}{4}$ -in., 25 gauge, 9-6 ft., 39c. each, 100 lots, 35c. each; No. 2, 13-16-in., 25 gauge, 9-6 ft., 43c. each, 100 lots, 39c. each; No. 3, $\frac{7}{8}$ -in., 25 gauge, 11 ft., 49c. each, 100 lots, 45c. each; No. 4, 1-in., 23 gauge, 10 ft., 49c. each, 100 lots, 45c. each; No. 5, 1-in., 27 gauge, 11 ft., 65c. each, 100 lots, 59c. each; No. 6, 1 $\frac{1}{4}$ -in., 27 gauge, 11 ft., 90c. each, 100 lots, 85c. each.

RECORDS—POPULAR and GRAMMAVOX Brand, 10-

in. double face, lateral cut, all instrumental—32c. in lots of 100; 30c. in lots of 1,000; 29c. in lots of 5,000.

GOVERNOR SPRINGS—\$1.00 per hundred; \$6.00 per thousand. Special price in large quantities for Motor Manufacturers.

Genuine Diamond Points for playing Edison Records, \$1.25 each, 100 lot, \$1.15 each; Sapphire Points for playing Edison Records, 13c. each, 100 lots, 14c. each; Sapphire Balls for playing Pathé Records, 19c. each, 100 lot 16c. each. Needles—Steel in stock at all times at moderate price as per quantity.

NEEDLE CUPS—\$17.50 per M. \$16.00 per M in 5,000 lots. Covers, \$7.50 per M.

COVER STAYS—No. 1, for Table Cabinets, 6 in. long, 9c. each, 100 lot, 7 $\frac{1}{2}$ c. each; No. 2, for Floor Cabinets, 9 in. long, 17c. each, 100 lot, 13c. each; No. 3, heavy for Floor Cabinets, 10 in. long, 20c. each, 100 lot, 16c. each.

Continuous Piano Hinges, 28c. per foot; 100 feet, 21c. per foot.

We also manufacture special machine parts, such as worm gears, stampings, or any screw machine parts for motor; reproducer and part manufacturers.

Special quotations given to quantity buyers in Canada and other export points.

Write for our 84-page catalog, the only one of its kind in America, illustrating 33 different styles of talking machines and over 500 different phonographic parts, also gives description of our efficient Repair Department.



No. 85—\$85

Lucky 13 Phonograph Co., 3 East 12th St., New York

BUILDING NEW EDISON POWER HOUSE

Plant Now Under Construction Will Develop 10,000 Horse Power and Cost \$500,000

There is now under construction at the plant of Thomas A. Edison, Inc., Orange, N. J., a new power house that, when completed, will prove a substantial factor in the operation of the various departments of the big institution. The build-



Chimney for New Edison Power House

ing will be approximately 100 feet square, and the equipment will develop 10,000 horse power. The new power plant will cost about \$500,000, and is expected to be ready in seven weeks. One of the features will be a chimney 202 feet, three inches high, which has just been completed, and the imposing size of which can be gleaned by a glance at the accompanying illustration of the same.

J. P. Constable, chief engineer of the Edison interests, is supervising the construction of the new power house, and A. M. Wolf, construction engineer, is in direct charge.

TO MAKE TALKING MACHINES

TIPTON, IND., July 6.—The Deterling Mfg. Co., formerly of Muncie, Ind., are now moving into a fine new factory building recently built by the Chamber of Commerce. The company will make a full line of cabinet talking machines, among the special features of which are patented sliding doors for modifying the tone, and patented zig-zag felt filing system holding about one hundred records. Geo. P. Bower is president, R. H. Woodruff, general manager. The machinery is now being installed and the plant will be in running order in thirty days. The company will build their own cabinets.

REAL FRIENDSHIP

"He is a man of firm friendships, I know."
"How's that?"

"He has lived in the same house with a man who has been learning to play the trombone for the past three years—and he still speaks to him."

One of the Edison convention visitors to the Edison plant was Mr. Eilers, Edison dealer at Spokane, Wash. After the convention Mr. Eilers went to Boston as the guest of chairman of the convention, George Lincoln Parker.

MICA

BEAUTY OF TONE
DIAPHRAGMS OF BEAUTY
INTERNATIONAL MICA COMPANY
Offices and Factory, 37th and Brandywine Streets, WEST PHILADELPHIA, PA.

HINTS FOR THE RETAIL MAN

F. A. Mulford Tells of His Experiences in Interesting Little Book That May Help Others

F. A. Mulford, manager of the Brunswick Shop in Coasts' store, Iowa City, Ia., has just compiled a most interesting little booklet under the caption "Hints for the Retail Phonograph Man," and which contains some excellent selling advice based on Mr. Mulford's actual experience in the field. Some of the excellent material contained in the book reads:

In conducting a retail phonograph department, of course the usual rules for retail merchandising apply—such as keeping the display floor neat and attractive and in every possible way to be on the alert to create a favorable first impression. The visitor is likely to be especially critical because the phonograph and record store is a "Temple of Music," and, as music is a fine art, an artistic and scrupulously clean display room is absolutely essential.

Link up, continuously, the records with the instrument. In talking with, or writing to, a hesitating prospective customer, emphasize certain attractive musical selections that you believe he would enjoy. This puts the instrument itself into the background, and avoids danger of boring the prospect.

As much as is possible, avoid going into details as to how the instrument is made; by taking it apart and displaying the mechanical parts you divert your customer's mind from the real issue—the music that is produced by the combination—the phonograph and the records. Music is what your prospect is after. Cause him to concentrate the mind on the music.

Music is what the prospect really needs. Try to sell him music. Convince him that he needs it, and he will want it.

After demonstrating with just a few records, if you feel that a favorable impression has been made, come to the point, try to close the deal; if you tried too soon, no harm is done; you can quickly resume the demonstration. Be always alert for another chance to try to close. By persistently trying, you will usually close a sale before the high point of interest in the instru-

ment is passed. Many a sale is lost by a too prolonged effort to convince the prospect as to the actual merits of the instrument.

If you fail to close the sale at this interview, be careful to appear a good loser; express your appreciation of the visit. Write a letter emphasizing the fact that he will always be welcome in your store, whether to buy or not.

Each month, select two or three of the best records on your new list, and make these records an excuse for an especial invitation to call again—just to hear them. By addressing an instrument prospect on the subject of some unusually fine selections, from time to time, he is frequently reminded of the sales person, of the store, and of the instrument.

The letter that follows has been found quite effective:

Dear Sir:—We all enjoy music; especially in the home. Personally, my home life would be robbed of a great part of its charm, if I could not have music there.

Last evening, my wife and I enjoyed ourselves immensely, right at home—with our phonograph.

While awaiting dinner, the Hawaiian guitars tinkling "On the Beach, at Waikiki" proved an excellent appetizer.

Our dinner was unusually enjoyable with the music of the Boston Symphony Orchestra.

After dining we settled down in comfortable chairs and listened to a fine concert. The rich tenor voice of John McCormack, singing "Little Grey Home in the West" and "I Hear You Calling Me," was really more enjoyable than if we had gone to a theatre to hear him.

"Carry Me Back to Old Virginia," sung by Alma Gluck, and the "Laughing Song," by Galli-Curci, were delightful.

Gounod's "Ave Maria," sung by the great soprano, Marie Rappold, with a wonderful violin obligato by Albert Spalding, was magnificent.

Such an array of talent on one program is only possible with a phonograph.

At the close of our evening, we set the automatic stop and retired, with the distant strains of "A Perfect Day" coming from the music room.

Open your home to this delightful flood of music. Order a phonograph to-day. The greatest possession that you have is your home. Nothing can add so much to your home as music.

Your.....is at the other end of your phone. Our phone number is.....
Very truly yours.

The Edison Phonograph Shop, conducted by Robert Sell, of Knutztown, Pa., recently gave an Edison recital at which Miss Irma Seydel, violinist, and Miss Marie Morrisey, contralto, were heard.



Let Brown Do It Right

*I'll Supply Your Cabinets
—Equipped, If You Wish*

Years of experience as a cabinet builder have taught me materials from A to Z. My painstaking cabinet makers know their business too.

*The "know how" we put
into it will save you time
and trouble*

Am prepared to build phonographs for you from your blueprints, or if you wish will submit designs of my own.

Will build to fit your "selling proposition."

The easy way for you—

Let BROWN Do It

Just write me about it

CHAS. C. BROWN

350 E. Water St. Milwaukee, Wis.



People can't take their big Grafonolas away for the Summer. And yet that's the very time for music. Answer?—Portable Models for Vacationists.

**Columbia Graphophone Co.
NEW YORK**

ELABORATE PLANS FOR TALKING MACHINE MEN'S OUTING

Committee Makes Special Trip to Bear Mountain to Complete Arrangements on the Spot—Baseball Game and Other Sports for Attractive Prizes Are Scheduled for August 7

All arrangements have been completed for the annual outing of the Talking Machine Men, Inc., to be held August 7 at Bear Mountain, and, according to present arrangements, this outing will provide many attractive features for the dealers and their guests. Notwithstanding the fact that the steamboat fare has been increased during the past year, and the cost of the dinner has also been raised, the committee decided to charge only \$3 a plate, the same amount as last year; this charge including the steamboat fare in addition to the dinner. The association expects to have a deficit because of this very moderate charge, and is planning to make up this deficit from the club treasury.

Through the courtesy of B. H. Roth, of West New York, N. J., a live wire Victor dealer, the entertainment committee of the Talking Machine Men, Inc., was given a chance to motor to Bear Mountain last month, and make arrangements for the outing. The trip was thoroughly enjoyed and the accompanying photographs present the committee during their stay at Bear Mountain.

Sol Lazarus, one of the most active workers on this committee, will donate the chest protector and mask for the ball game, and Mr. Roth will donate the baseball bats and the balls for the game. The association will also give interesting prizes for the various races, the official

schedule for which will be announced at a later date.

Talking machine dealers in local territory are evincing keen interest in this outing, and it is



Messrs. Roth, Lazarus, Mielke, Galuchie and Coughlin

expected that a banner attendance will reward the efforts of the entertainment committee to make this year's event a memorable one for the dealers. Last year's outing was very success-



H. Meilke Saving "Jim" Davin for the Army. The committee in charge of the 1918 event promises to make August 7, 1918, a red letter day for the members of the local talking machine trade.

MANY "BUTTERFLY" MOTOR SALES

Leonard Markels, New York, well-known manufacturer of Markels motors, etc., has been visiting the trade in the East during the past few weeks, and has called upon many of the leading manufacturers in this territory. He states that conditions are unusually pleasing for this time of the year, and wherever he visited the manufacturers expressed optimism and confidence in the business outlook.

Mr. Markels received large orders for the well-known Markels "Butterfly" motor, which is gaining in popularity day by day. This motor has many distinctive features that have made it a prime favorite with the manufacturers, and several of the houses who placed orders with Mr. Markels on his recent trips expressed their intention of using this motor exclusively during the coming year. In order to keep pace with the demand for the Markels products, Mr. Markels is planning to augment his factory space materially in the very near future, and has already taken the necessary steps in order to secure larger quarters for manufacturing purposes.

CATALOGS IN VARIOUS LANGUAGES

Pathé dealers received this week from the foreign-language record department of the Pathé Frères Co. several catalogs featuring Pathé foreign-language records which can be utilized to advantage in developing this important branch of the record field. Among these supplements are lists presenting Italian, French, Polish and Hebrew-Jewish records, and, as the demand for this type of record is growing steadily, these lists are issued at an opportune time. All of these lists feature records that were carefully selected for their particular appeal to the different races interested in this type of record, and the Pathé Frères foreign-language record department is planning to co-operate with the dealers in every possible way in developing foreign record sales.

Here is a Booth Proposition That Will Save You Money

We are in a position to build attractive sound-proof booths from **\$100 up**. We have been building booths, record racks, and store in-

teriors for three years, and can save you money on your installations. We use the best materials available and guarantee our work in every detail.

Let us quote you prices

H. MICKELAS - 387-389 South 1st Street - Brooklyn, N.Y.

WAR HAS LITTLE EFFECT ON PACIFIC COAST BUSINESS

Public Still Shows Great Desire to Own Talking Machines and Records—Stock Question the Only Problem—New Concerns Enter the Field—General News of Interest

SAN FRANCISCO, July 3.—The talking machine business seems less affected by the war than any other branch of the music industry. Liberty Loan drives, Red Cross appeals and War Savings Stamps subscriptions have followed each other in rapid succession, but they are unable to halt the buying of talking machines and records. The trade has done its duty in each of these money demands and the people of San Francisco have gone way over the top in every event, yet there is always plenty of money for talking machine music which appeals to the public, perhaps more than music in any other form. It may be because the talking machines make their appeal to the so-called common people that their popularity shows such steadiness amid the falling off in the demand for so many articles which were previously considered perhaps even more essential than they. This is the era of the common people. The man with the hoe, the hammer and drill, in other words, the mechanic is now the man who has the money, and he is buying what he wants. San Francisco mechanics are making more than ever before in history and the ranks of well-paid laborers are being constantly swelled by accessions from other ranks of life. With the multitude receiving high wages what is to prevent the continued success of the talking machine? Manifestly, only one thing is going to keep down future sales. That is the lack of stock. This is more or less a ticklish question with the dealers, and some makes of machines are being restricted seriously, but as yet in the gross there has been no shortage of talking machines in this market. Some of the dealers are very enthusiastic over their June business and none of them has found the month's sales to show a less volume than a year ago at this time.

Conditions Good in Northwest

Andrew G. McCarthy, treasurer of Sherman, Clay & Co., and manager of the wholesale distribution of talking machines, has recently returned from the Northwest, where he visited the company's branch stores at Portland, Seattle, Tacoma and Spokane. He found that business was in good shape in that territory, especially in the cities where a great deal of shipbuilding is in progress and large payrolls prevail.

Increased Business on First Floor

Edward Humphreys, in charge of the record department of Byron Mauzy, reports that there has been a large increase in the sales of records since the talking machine department has been moved to the first floor. Mr. Humphreys has had to bring in a number of records by express from the East in order to keep up with the demands of his customers.

F. B. Travers, manager of the Phonograph Shop on Stockton street, has just returned from the southern part of the State where he signed up several new agencies for the Sonora machine. He feels that this section of the State is pretty well covered with agencies for the Sonora, and with the prospective shortage in supplies he will probably not make further effort to appoint agents in that section.

Fred A. Dennison, district manager for the Columbia Graphophone Co., says that his stock of machines is about exhausted. However, he has a good stock of records and more are constantly arriving and this is keeping business lively for him.

Large Shipment of Pathé Machines

The Stern Talking Machine Corp. has recently received a large shipment of Pathé machines, and a number of other machines are on the road to this company. A demand has arisen for the higher grade Pathé machine at this shop and a number of the cheaper grades were exchanged this month for better instruments.

The Oakland and Richmond branches of the Stern Talking Machine Corp. both report very satisfactory business for the month.

C. E. Goehr, Western branch manager for

Pathé Frères, visited the Stern shop this month and later went to Los Angeles, where it is understood he is about to close a number of Pathé agencies.

Sherman, Clay & Co. say that both the wholesale and retail talking machine departments made a much better showing during the month than might be expected under the general condition of trade and the many demands being made upon the purses of the public.

Attractive Edison Window Display

The Edison Phonograph Shops, where the Edison is retailed in this city, frequently have very attractive window displays. The most recent of these displays was a large picture of a concrete viaduct of the Lackannock railroad. The window dresser compares this striking engineering feat to the Edison machine. Both are masterpieces of skill.

James J. Black, who is one of the directors of the Wiley B. Allen Co., and has charge of the talking machine department for that music company, recently took a trip through the southern part of the State in his machine. He was joined on part of his trip by Mrs. Allen and party.

Adds New Phonograph Department

The Irvine Music Co., which was formed by R. S. Irvine, formerly connected with the Eilers Music Co. in this city, has just added a phonograph department, which Mr. Irvine predicts will be a winner. Mr. Irvine has many friends both in and out of the music trade in this city and his new music house is establishing a reputation for reliability.

The Clark, Wise Music Co. has been featuring a small phonograph for vacation purposes and says that business has been especially brisk in this machine. Mr. Wise has just returned from his own vacation, which he spent in Portland, and while he was glad to get back to San

Francisco, which has been his home for so many years, he was full of praise for the northern city and said that the music business was booming in the "city of roses."

The Emporium, which is San Francisco's largest department store, has been conducting a birthday sale, and although there were no reductions made in prices in the talking machine department, the store reports that the large crowds attracted by reductions elsewhere purchased heavily of phonograph goods, especially of records. The sale of machines was also larger than usual for the period.

Plans for Allied War Exhibit

At the Allied War Exhibit, which is to be given in this city July 7-28, is expected to draw great crowds from the entire Bay region, and the talking machine men are preparing to attract the attention of the crowds by their window displays and meetings, a number of which have been scheduled during the progress of the show. The occasion is expected to attract greater crowds to San Francisco than any other event planned for the year and the music dispensers are going to take full advantage of it.

NEW QUARTERS FOR CRAFTS-STARR

RICHMOND, VA., July 8.—A. B. Seigel, of Brooklyn, N. Y., has been appointed a member of the traveling staff of the Crafts-Starr Phonograph Co., of this city, factory distributors for Starr phonographs and Gennett records. Mr. Seigel assumed his new duties last month, and has already achieved pleasing success in his visits to the dealers in this territory.

The Crafts-Starr Phonograph Co. has leased for a term of years a three-story building at 414 East Marshall street, which will be utilized for storage purposes. This building is a new one, which has just the right kind of equipment to make it ideal for warehouse use. Stocks are being accumulated rapidly, and the company feels sure that it will be able to render its dealers reasonably satisfactory service the coming season.

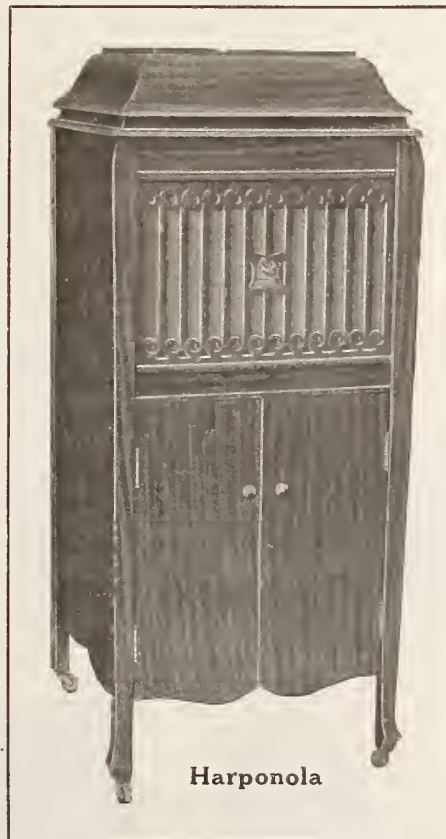

Harponola

MAKE YOUR PLANS NOW

Do not wait until the Fall season is here to secure your stock.

If you carry our line, place your order NOW.

If not, NOW is a good time to investigate.

Send for particulars.

CABINETS

Equipped or Unequipped for Manufacturers Jobbers — Dealers

Guaranteed and Manufactured by

THE CELINA FURNITURE CO.
 CELINA :: :: :: :: :: OHIO

ST. LOUIS WHOLESALERS WATCHING FICTITIOUS ORDERS

Believe That Some Dealers Are Placing Orders Beyond Their Needs on Chance of Getting Larger Proportion of Actual Deliveries—Patriotic Records in Demand—Trade Situation Reviewed

St. Louis, Mo., July 5.—According to wholesale salesmen, the easiest thing in the talking machine line just now is to write a large order for a retailer. The hardest thing to do, according to the same authority, is to get the stock to fill that order. Some of the salesmen are of the opinion that a fair percentage of the orders now being filed are fictitious, as the dealers have at last realized that there is to be a scarcity of machines and they are placing orders for a larger number than they actually want or expect, with the idea that they will be filled proportionately.

Some of the orders given, however, are to be disappointed in this for one jobber, after noting the size of an order, wrote to the customer:

"We note the order recently given to our firm by you and we thank you for it. But we would like to know what reason you may have for expecting that your business within the next three months will exceed by 100 per cent. that of last year? This expectancy appears in your recent order and, also, we note that you have added the — machine to your list. Unless we are satisfied that you have a reasonable expectancy of this increased business, we shall be compelled to distribute new stock to you proportionate to your orders of last year."

The idea of basing distribution on last year's business appears to be very general. Jobbers and assemblers here are not expecting as much stock as last year and, apparently, have little hope of meeting legitimate demands for their merchandise and they are going to do their best to see that the unfair distribution based on fictitious orders does not work injury to the dealer who is playing the game fair and ordering what he thinks he will need and who will not yell when compelled to put up with a shortage.

The retail business is quiet. There is no mistake about that, especially in the city. It may be that some prospects have got tired of trying to get just the machines that they want and have given up, but there are not as many machine inquirers visiting the various stores as there was two months ago. The slump in inquiries set in just after the Red Cross drive and the trade has not entirely recovered. Practically every retail store is short of the lines of machines most in demand—usually those running from \$50 to \$175, according to the nature of the trade catered to by the store.

Some of the assemblers still have a fair display of machines, but they are going slowly and are turning down many orders at wholesale because they believe that they can sell most of

their output at retail to drop-in customers and in this way make more money and a larger profit than by selling at wholesale.

During the last few weeks representatives of the Air Production Board have taken from the local planing mills many panels made for talking machine cabinets. The planing mills, it appears, have been left free to keep on making these panels, but deliveries to their private customers are restricted closely and the stock must be at the disposal of the government at all times. Some of the assembly plants were well fortified with motors and arms but can use these only slowly under present conditions.

"Everybody is buying records," is the way a number of the retail men express the situation, after saying that the machine market is quiet. There appears to be a never-ending demand for the records and stocks are fairly well filled and at least good substitutes for the records in demand are on hand, so the receipts are running high.

Of course the "war stuff" is the strongest in the records sales, but a good many machine owners are seeking relief from the "war" by going back to standard music. This, of course, includes the long line of operas and renewed popularity is shown by folk songs. The latter vogue is believed to be due somewhat to the recent community sings. Now almost every public meeting begins with the public joining in several songs. "America" or the "Star Spangled Banner," of course, and then one or two others. "Dixie" is used a great deal here and "Onward Christian Soldiers," "Long, Long Ago" and "Old Black Joe" are other types. Many persons are learning that there really are words to these numbers, which they have known mostly as band pieces and after singing them themselves in the crowds they buy a record and listen to them at home, appreciating the beauties that have been hidden from them during their thoughtless days as a mere listener to the instrument.

John J. Schlichter, traveler for the Silverstone Music Co., has entered the military service and Retail Salesmanager Schlude has been promoted to take his place. President Silverstone will go to San Francisco with the Ad Club delegates for the big meeting there and will then go to Los Angeles or some other point south for the rest of the summer, hoping to entirely regain his health by fall.

The Rice-Stix Drygoods Co., The Witte Hardware Co., and the Phoenix Furniture Co., dis-

tributors in this city for the Vitonola talking machine, which is manufactured in Chicago by the Vitonola Talking Machine Co., all report an active demand for this product.

Wholesale Manager Salmon of the Columbia Co. is preparing to enter the army at any time now. His position in the draft list has had its ups and downs but his ward is nearing the end of the No. 1 list, which includes Mr. Salmon. He asserts that he is going to leave his customers all well sold on patriotic records that they can play and remember him by. And as he has a host of friends he will not be forgotten by them.

At Aeolian Hall much satisfaction is expressed with the trade prospects, both wholesale and retail. Manager Guttenberger of the Vocalion department says that only stock restricts their field of operations. The jobbing business is being extended slowly and only the most desirable dealers are being put on the list.

The Fourth of July Vocalion record made a very great hit here. Two of them were used as the center of a window display and the response was immediate. Buyers were attracted by the novelty of the colors and came in to ask questions, remained long enough to listen and then bought.

The entire list of Vocalion records has made a most decided hit. The favorable impression made apparently improves with time. This is the second month and already they have established a clientele.

At the end of the fiscal year, the first of the month, the improvement of the totals over the year before at Aeolian Hall was pronounced surprising to even those whose duty it was to keep a watch on them. The recent record business has been amazing.

It was told at Aeolian Hall that C. P. Byers, Vocalion manager at Cincinnati, had reported the birth of a son, named William Kale Byers. The announcement has resulted in heartiest congratulations being extended.

Manager Cone at the Artaphone warerooms says that he has only one complaint, that the callers there want to buy too many machines. "We are doing the best we can with the materials and labor available," said Mr. Cone, "but we decline to accept orders that we cannot fill nor to entirely forget our former customers. It really is distressing to have to refuse to talk to a man ready to give you a check for merchandise, but such things must be done. The man I least want to see is the man who wants to talk about 100 machines."

Two new styles of Artaphones with spruce sound boxes have been on exhibition at the Artaphone warerooms recently and have attracted much attention.

AMERICAN

AMERICANS embody all the good qualities and special features of phonographs, clear in tone, beautiful in design, finest finish, smooth running motors.

We stand back of every American



No. 22



No. 13



No. 5



No. 8



No. 9



No. 10



No. 11

**American
Phonograph Co.**

39 Fountain Street, N. W.
GRAND RAPIDS MICH.

**Just the thing for Automobilists !
A Military Trunk Grafonola Outfit,
sturdy, light, companionable—
easy to sell.**

**Columbia Graphophone Co.
NEW YORK**



UNITED STATES TRADE BALANCE IS THREE BILLIONS

Figures for First Year of Our Participation in the War Show an Approximate Balance of \$3,000,000,000 in Our Favor—Imports Increased Nearly \$350,000,000 Over Preceding Year

WASHINGTON, D. C., July 5.—The United States closes its first fiscal year as a participant in the great war with a trade balance of approximately \$3,000,000,000. Exports for the fiscal year will total \$6,000,000,000, as compared with \$6,290,048,394 in the twelve months ended June 30, 1917. Imports increased from \$2,659,355,185 last year to about \$3,000,000,000 this year.

Such a showing was regarded as very gratifying by Government experts and no uneasiness is felt because the trade balance declined \$630,693,209 as compared with 1917. Steps are being taken, however, to retrieve the loss as fast as possible in the coming year by a fuller utilization of available tonnage in foreign trade, especially small boats not needed for transatlantic service, which can be used to carry surplus manufactures to Latin-American countries and reduce the shipments of gold made necessary by the United States becoming a debtor nation of the other pan-American republics.

Gold Flows to South America

The increasing flow of gold to South America was one of the most striking features of world trade in the last twelve months. Products of the Latin-American countries—meat, grain, rubber, hardwood, nitrates, tin, platinum—have been bought in large quantities by the Allies, which

have had less and less goods to ship in return as the war progressed. The result has been that the Latin-American countries have been paid in gold, which they hardly have been able to spend.

Imports of South American goods by the United States alone in the last twelve months have totaled nearly \$600,000,000, while exports to the same continent have been only about half as much. The United States also is a debtor to Asia, Oceania and Africa, despite the growth in sales to countries of those continents. Europe and North America, including Canada, through which is shipped much of the exports going to Great Britain, continue to look to this country as their great source of supply.

U. S. Rationed Neutrals of Europe

The European neutrals were strictly rationed by the United States during the fiscal year. Exports to Denmark, Norway, Sweden, the Netherlands and Spain were cut in some instances as much as 90 per cent. Denmark received only about \$5,000,000 worth of goods from this country, as compared with approximately \$50,000,000 in 1917.

Restrictions on shipments of many commodities had less effect on the total value of trade than on the volume, because of steadily increasing prices for almost everything.

The loss in the trade balance was due largely to decreased exports of manufactured goods.

APPRECIATES WORK OF STAFF

The staff of the Otto Heineman Phonograph Supply Co. was advised the first of the month by Otto Heineman, president of the company, that in view of the fact that June had been the biggest month in the history of the company both in sales and in the orders booked, a \$5 War Savings Stamp would be distributed to every member of the office staff and every foreman employed in the factory. In addition a \$5 bonus was also given to the members of the staff, and this tangible distribution reflected Mr. Heineman's appreciation of the efforts of his force during the month of June. Incidentally, it is interesting to note that this is the fourth War Savings Stamp that has been given to the Heineman employes, and many of the employes are also working earnestly in behalf of the War Savings Stamp movement in their social fields.

NEW BRUNSWICK CO. STORE OPENED

The Brunswick Munn Music Co., of Ft. Dodge, Ia., opened its headquarters at 1021 Central avenue last week. This store is one of four branch stores operated by the same concern in Iowa, the other branches being in Cedar Rapids, Cedar Falls and Waterloo. A. L. Adams is the manager of the new store, which will handle a full line of pianos and players, in addition to Brunswick phonographs and records.

VICTOR RECORD BY THE FLONZALEYS

Famous Quartet Plays a Mendelssohn Selection on First Recording for Victor Co.

The big feature of the Victor Co.'s record list for August is the announcement of the first record to be made by the famous Flonzaley Quartet, recognized at the present time as one of the leading, if not the leading, organizations of its kind in the country. Thus the Victor Co. adds another bright star to the galaxy of famous recording artists and organizations, whose efforts find an outlet through the medium of Victor records. The first record made by the Flonzaley Quartet is "Canzonetta" from Mendelssohn's "String Quartet in E Flat," Op. 12, No. 2, and said to be a most excellent exemplification of the musicianship of the Flonzaleys. More records by this famous quartet will shortly make their appearance in the Victor list.

MODERN MOULDING FOR WALL BOARD

MEMPHIS, TENN., July 6.—The W. R. Friedel Co., of this city, is receiving many inquiries from dealers throughout the country regarding its new system of utilizing modern moulding for wall board in the construction of demonstration booths. The company has worked out detailed schedules to tell the dealers just how to utilize these mouldings, and all of the material covered in these schedules, with the exception of the mouldings, may be purchased locally if the dealer prefers. This system, which embodies many distinctive features, has been heartily endorsed by several of the leading talking machine companies, who believe that it can be utilized to excellent advantage by the dealers in the construction of demonstration booths.

Genuine Period Styles

Authentic adaptations of Adam, Louis XVI, Sheraton and Queen Anne periods, harmonizing perfectly with the styles whose names they bear, are a feature of the case work on the Marvelous

MAGNOLA "Built by Tone Specialists"



Watching the Music Come Out

Give us the Opportunity to tell you more about this and other sales-making features of MAGNOLA construction, by sending us your name and address.

We have a handsome catalog, illustrated in colors, that tells Magnola's story—and is yours for the asking.

MAGNOLA TALKING MACHINE COMPANY
OTTO SCHULZ, President

General Offices
711 MILWAUKEE AVENUE
CHICAGO

Southern Wholesale Branch
1530 CANDLER BLDG.
ATLANTA, GA.

The BEST TALKING MACHINE NEEDLE

On the Market—Packed in Counter Salesman



50 Needles to a box and they retail at 10c. per Box.
60 Boxes to a package \$6.00.
This package costs you \$3.90 net.
Your profit is \$2.10 and your customer gets a needle that will give satisfaction.

The Fred. Gretsch Mfg. Co. 60 Broadway
Brooklyn, N.Y.
Manufacturers of Musical Instruments
Canadian Wholesale Agent, H. A. BEMISTER!
10 Victoria St., Montreal, Can.

WHOLESALE EXCLUSIVELY

from the

Two Biggest Cities in the U. S. A.

the 2
Largest Distributors

New York
Talking Machine Co.
119 W. 40th. Street,
NEW YORK

Chicago
Talking Machine Co.
12 No. Michigan Ave.
CHICAGO



FROM OUR CHICAGO HEADQUARTERS

E. P. VAN HARLINGEN,
Manager

World Office
Republic Bldg., 209 South State St., Chicago
Telephone: Wabash 5774

CHICAGO, ILL., July 10.—The record situation has seen much improvement within the past month, and as a result the wholesale trade of Chicago was partially able to satisfy the demands made upon it for standard numbers. However, the relief was not great enough in any particular instance to enable the wholesalers to entirely take care of back orders, but enough standard records of all makes came in in numbers large enough to show that the manufacturers were doing their best in order to relieve the situation.

There is still a large demand for the medium and high-priced machines, but this, as is well known to the trade, cannot be taken care of due to the lack of labor and shortage of material. The machines which are being shipped are coming through on schedule time and the wholesalers are not experiencing much trouble due to railroads. Shipments of the small table machines have been coming in in fair quantities and the demand for these instruments has been taken care of in a fine way. In general the wholesale dealers report that the demand made upon them by the Chicago retailers in no way approaches the demand made upon them by the country dealers.

In the retail trade it seems as though the demand for patriotic and popular record numbers will never be satisfied. The dealers are experiencing some difficulty in continually turning down their clientele and in trying to unload what they have in stock. As far as operas and classical numbers are concerned it is an easy matter to satisfy the local trade, but the dealers are finding it hard to get enough of the popular numbers and military dance music. This demand is being taken care of in a small way at present, more so perhaps within the past month than with any other month so far this year and from present indications the retail dealers are anticipating further relief along these lines to come gradually.

H. A. Beach Entertained

H. A. Beach, head of the Victor traveling department, accompanied by Messrs. Yeager and Browning, Victor travelers for Illinois and Ohio, were recent visitors to the Chicago trade. During the visit here Mr. Beach was entertained at a basket outing by L. C. Wiswell, manager of the Victor department of Lyon & Healy, and

Mrs. Wiswell and daughter. Mr. Wiswell took the party in his auto for a visit to the Great Lakes Naval Training Station, and from there the party motored to Hubbard Woods for luncheon. After luncheon Mr. Wiswell drove Mr. Beach back to the Great Lakes Station, where he boarded the electric car for Milwaukee. It is the intention of Mr. Beach to make a tour of the Central States territory before returning to his headquarters at Camden.

Attractive Lyon & Healy Window

The Lyon & Healy show window which faces both the corner of Wabash and Jackson is very attractively fitted out depicting a fishing camp. A figure representing the fisherman, dressed in appropriate costume, is standing in the foreground dangling his line in the bubbling brook that flows around the window wherein there are quite a number of live brook trout. The background is decoratively arranged to represent a wood and immediately in back of the fisherman there is erected a pup tent, in front of which there is a campfire burning. The conventional Victor dog is replaced by a stuffed brindle bull, which is chained to a tree stump near the tent. By the side of the camp fire there is a small table Victrola, suggesting "music in the camp" and bearing the caption, "Take a Portable 'A-Camper' Victrola Outfit and Carrying Case With You."

Had Shorter Vacation Than Usual

L. E. Noble, manager of the wholesale Victor department of Rudolph Wurlitzer Co., has just returned from a week's vacation trip to Lake Koshkonong, Wis., where he was accompanied by his wife and child. Mr. Noble was unable to stay the customary two weeks on his vacation this year, owing to business matters which needed immediate attention, but anticipates being able to return for another week's rest-up about the first of September.

Harold Huemoeller, Illinois wholesale Victor traveler for Rudolph Wurlitzer, was called to the colors the latter part of June and is now in training at Camp Grant. He was one of Manager Noble's best men and had been connected with the Wurlitzer Co. about a year.

Move Offices

Sam J. Turnes, advertising manager for Brunswick-Balke-Collender Co., has had his department removed from the general office building

at 633 South Wabash to No. 163. This is the store room formerly occupied by the retail Brunswick Shop, prior to its removal to the present location. Mr. Turnes has his new offices attractively fitted out and is very well pleased with the new location as well as the bevy of beautiful and charming young stenographers he now has as his assistants.

Increase List Prices

The Vitanola Talking Machine Co. has just announced an increase in the retail listings of their product which is now in effect. The increase embraces the entire Vitanola line, and is as follows: No. 25 is increased to \$27.50; No. 50 to \$55; No. 67 to \$85; No. 100 to \$110; No. 125 to \$135; No. 150 to \$165; No. 175 to \$190. These increases it is stated will allow a larger margin to the dealers. It is also stated that the new 175 will soon be supplied in Circassian walnut. Jeffrey B. Schiff, sales manager of the company, stated that business has been very favorable with him and both the eastern and western business is very good. "We have opened up several new accounts around the country," he continued, "and the dealers are having a very good demand for high priced goods. The growth of this demand has been very noticeable during the past six months. We will soon have ready for the trade a beautiful period model of the Louis XIV design. This is of the table type machine equipped with a large and powerful spring motor playing both lateral and vertical cut records. It is very artistically designed and will be equipped with a new style tone chamber built especially to conform with this type of machine. It can be had in any of the woods desired and looks especially beautiful when finished in either the antique or Circassian walnut. The new instrument will be known as the Vitanola Model No. 17.

New Incorporation

A new company to be known as the Illinois Talking Machine Co. has just been incorporated under the State laws of Illinois with \$5,000. The officers are Edwin Frankel, president; J. L. Isaacs, treasurer, and Garret Woodward, secretary. The new company, it is stated, will manufacture high-grade cabinet talking machines. The first model to be put upon the market will be known as the "Verdiola" grand concert. The

(Continued on page 69)

THE "WADE" FIBRE NEEDLE CUTTER

assures "20 or more" *Original New Points to each Fibre Needle*

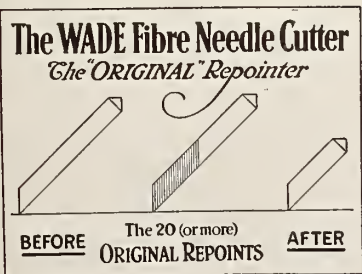

—and therefore is the most economical Fibre Needle Cutter on the market. You know the many advantages of using Fibre Needles—more natural reproduction; more tunes for one cent; no wear and tear on records, etc., etc., but, do not make the mistake of buying anything but the best Fibre Needle Cutter.

The Wade { is the oldest Fibre Needle Cutter on the market—
sells on demonstration—
never fails to give satisfaction—
is made in two styles—\$1.50 and \$2.00.

Usual trade discounts—Write for samples or Order from your regular Distributor

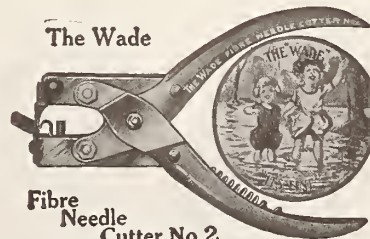

Price \$2.00

WADE & WADE, 3807 Lake Park Ave., Chicago, Ill.

Lyon & Healy



L. & H. Fibre Needle Cutters and Needles

- ☐ Increased production has enabled us at last to have on hand an adequate supply of this most popular Fibre Needle Cutter.
- ☐ It is so simple in construction as well as in operation that it has become one of the largest selling Victrola accessories.
- ☐ Fibre Needles are economical. They reduce needle cost because they can be used several times. They never injure the record.
- ☐ Send for a trial order of *Lyon & Healy Fibre Needle Cutters* and B & H Fibre Needles.

Are You Using Our New Window Card Service?

Art Window Cards (Size 14x22) featuring the best selling new Victrola Records, illustrated in colors, \$1.25 per month. Orders accepted now for the August 1st release.

Everything Known in Music

Lyon & Healy

Victrola Distributors
CHICAGO

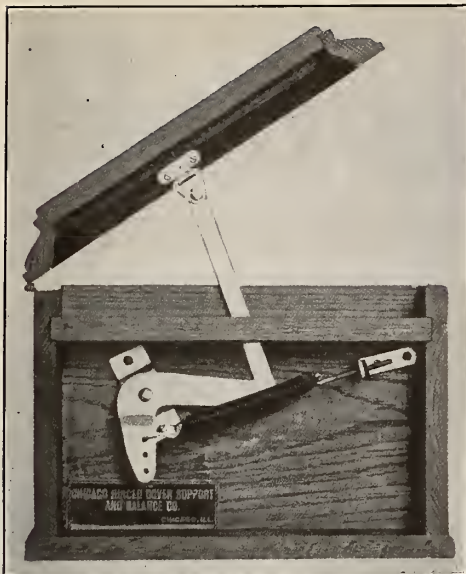

(Pat. Applied For) COVER BALANCE No. 1

What's Wrong With Your Sales?

Why is your competitor getting all of the business? Your cabinet work is just as good as his, BUT his equipment (which is 50% of the battle) is "turning the trick."

The Chicago Cover Balance

was the first cover balance in the field and has proven its worth by the fact that over 75 of the best known makes of talking machines are equipped with it.

EQUIPMENT COUNTS

The cover is "PUT" and "STAYS PUT"

WE ALSO MANUFACTURE CONTINUOUS AND EMPIRE TOP HINGES

Chicago Hinged Cover Support and Balance Co. 2242-44 W. 69th Street CHICAGO, ILLINOIS

FROM OUR CHICAGO HEADQUARTERS—(Continued from page 67)

business offices and salesroom will be maintained in suite 411, 56 West Washington street, and the factory, which is equipped with the latest and most up-to-date machinery for the manufacture of talking machines is located at 1234-36 West Van Buren street. The sales will be handled by both Mr. Frankel and Mr. Isaacs and the manufacturing end of the business will be conducted by Mr. Woodward, who by the way is well known to the talking machine trade of this city and familiar with every detail in the manufacturing of talking machines. The new company expects to have models of the line on display in their showroom in the general offices within a few weeks.

J. H. Steinmetz a Busy Traveler

J. H. Steinmetz, president of the Empire Talking Machine Co., is spending a great deal of his time in traveling lately, having but recently returned from a week's trip to New York. On his return he brought back news that will be received with much joy by Empire dealers. The good news is that he expects to be able to announce something big regarding a new edition of Empire records about August 1. Upon his return from New York Mr. Steinmetz spent a day in Chicago and then left for Culver, Ind., accompanied by his son, John, Jr., who but recently matriculated as a student in the well-known Culver Military Academy. After taking leave of his son Mr. Steinmetz went to Indianapolis, where he spent several days in looking after the Empire factory in that city and calling on the trade.

Emerson Co. in New Quarters

After much difficulty experienced, due to being held up by workmen remodeling their new suite of offices at 7 East Jackson Boulevard, the Emerson Phonograph Co. at last made the move and are now comfortably located in their new headquarters. A lengthy description of these new quarters appeared in the reading

columns of the World some time ago. Manager F. W. Clement is now in a better position to take care of his trade, owing to the increased stockroom and shipping facilities. The stockroom alone occupies about four times the space he had at his old location. The increased amount of stock and shipping facilities has enabled him to put on additional help both in the stock and shipping rooms as well as adding to the stenographic forces. Manager Clement is very well satisfied with the present business conditions and states that the business for the summer months was by far greater than he had dared anticipate. Mr. Clement recently spent several days entertaining H. L. Leeming, general manager of the Emerson Phonograph Co., who was in Chicago on a short business visit.

Gold Star on Service Flag

The Chicago office of the Columbia Graphophone Co. has placed a gold star on its service flag in memory of Gregory A. Dorian, who was killed in action with the marines on April 30. Mr. Dorian was one of the most lovable and well liked of the Columbia office force and had been connected with the billing department for quite a while. He was a son of the late John Dorian, who formerly managed the Chicago Columbia office and who, by the way, was famous for what is said to be the biggest deal ever pulled off in the annals of the phonograph history. This brave young American soldier was also a nephew of Marion Dorian, chief auditor for the Columbia Co.

Improvement in Record Situation

"We have been receiving some excellent shipments from the Victor factory lately," stated G. P. Ellis, sales manager of the Chicago Talking Machine Co., and from present indications it looks as though these good shipments will continue to come through. The standard numbers that were out of stock for several months

past came in in fairly good number and those dealers who had patience profited thereby.

However, we were not able to give entire relief to the record situation, only partly, but it helped out materially in filling back orders. The decrease in the receipt of talking machines from the Victor factory for the past six months was to be expected because of the tremendous difficulty being experienced by them due to both labor and material shortage. In spite of these difficulties, however, the shipments received during these months were wonderful. From present indications there is no telling at what rate we will be able to receive machine shipments from the factory, but we are optimistic and therefore expect that there will be a favorable increase gradually."

Good Demand for Brunswick

"Shortages of both labor and material continue to be the main factors governing the production of talking machines," stated H. B. Bibb, general manager of the phonograph division of the Brunswick-Balke-Collender Co., "and if it were not for these two factors the manufacturing trade in general would far surpass its wonderful production record of last year. It can be readily seen by those in a position to know just what the number of talking machines produced this year would amount to as based upon the number of orders that are being received. With ourselves we are away behind on orders and expect to be so for the balance of the year. We find that the demand for talking machines is inclined towards the higher priced instruments and our records show that the demand for our number 175 machines is greater than any other."

Like the B. & H. Repointer

The B. & H. Fibre Mfg. Co. report that the demand for the B. & H. Repointer for sharpening fibre needles is steadily increasing as the

(Continued on page 71)

TRANSFER NAME-PLATES

We make the Transfer Name-Plates and Trade-Marks for the largest talking machine manufacturers in this country and for dealers in every state.

YOUR NAME, Mr. Dealer, on every machine brings the owner back to you for records and his friends to you for a machine.

Samples, Suggestions and Sketches Furnished Free

THE MEYERCORD COMPANY, CHICAGO

Largest Manufacturers of **DECALCOMANIA** Transfer Name-Plates



The Brunswick

ALL PHONOGRAPHS IN ONE

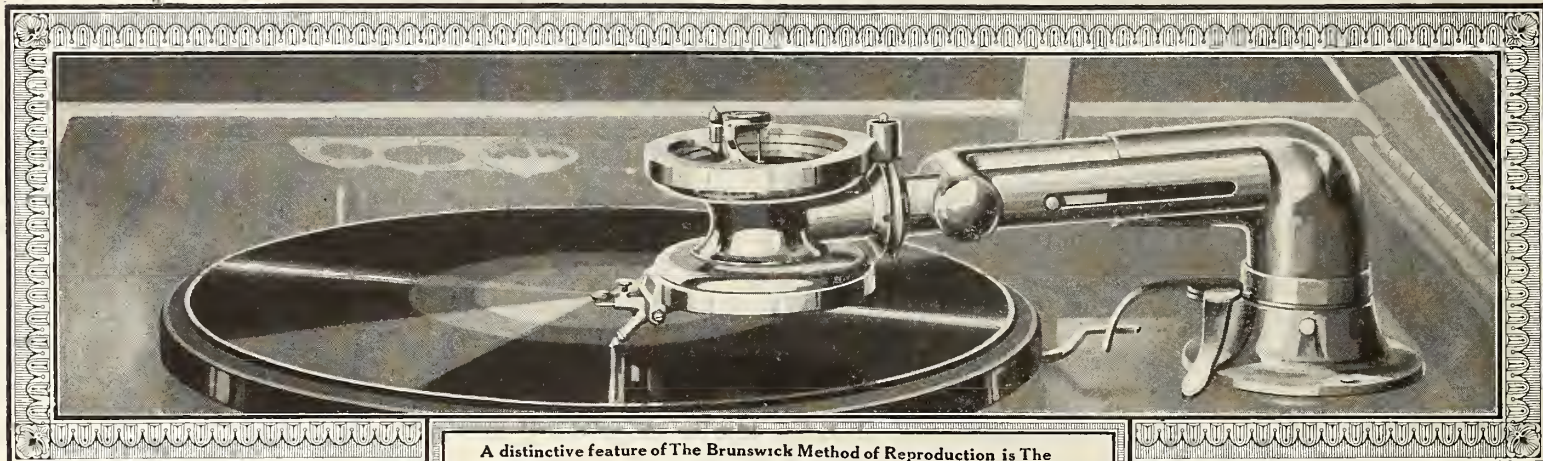

A distinctive feature of The Brunswick Method of Reproduction is The Ultona, pictured above, in position for playing a Fat's Record. The Ultona is instantly adjustable to play any record, whatever make.

Tones Hitherto Lost

Now Brought Out in Rich Clarity by
The Brunswick Method of Reproduction

ASK your customer to think of the finest toned phonograph he ever heard, the loveliest record — then think of it played infinitely better.

Tell him that such is no longer an ideal — but an accomplished creation — an actual, buyable improvement.

Once a person hears The new Brunswick Phonograph he will voluntarily discard old conceptions, old standards. Each record gains new significance!

Such a bettered instrument was inevitable. Some instrument was certain to offer the advantages now presented in The Brunswick Method of Reproduction.

This is one of the greatest achievements in phonographic history — opening a new epoch.

Brunswick Tone now commands first consideration. And people are asking themselves if

they can be content with less. Few can.

Never So True

The simplest way to prove the added charm of Brunswick tone is to choose the most difficult records of all and play them on The Brunswick. Then suggest to your customer to compare this with other reproductions.

Piano records afford the severest test. Also the records of symphony orchestras.

On The Brunswick, piano notes are piano-like. Reproduction is perfect.

There is not the slightest suggestion of the zither nor the harp, a resemblance which has often disappointed when piano records were played.

In every comparison, you can convince your customer of Brunswick superiority. Make as many tests as he wishes. He will never hear The Brunswick's equal.

The Latest Way

The Brunswick Method of Reproduction includes the playing of all records, whatever make. This is accomplished by The Ultona, an entirely new and exclusive reproducer. It is instantly adjustable, presenting to each type of record the exact needle, diaphragm and weight.

Each record is played at its best, according to its own requirements. No other phonograph offers The Ultona.

Another feature of The Brunswick Method of Reproduction is the all-wood Tone Amplifier, built like a violin. No metal is used in this delicate throat — the sound waves have an opportunity to expand and contract in a natural way. Thus metallic and harsh notes are ended.

In a dozen ways The Brunswick Method of Reproduction is far in advance. No one can afford even to think of a phonograph without hearing The Brunswick first.

The Brunswick Retails from \$32.50 to \$1,500

DEALERS: If you have not received the latest Brunswick proposition, write today. For those prepared to do a large business, we offer an unusual opportunity. Our proposition is a money-maker.

Branch Houses
In Principal Cities of United
States, Mexico and
Canada

The Brunswick-Balke-Collender Company
General Offices: Chicago

Canadian Distributors:
Musical Merchandise Sales Co.
Excelsior Life Building
Toronto

(1225)

FROM OUR CHICAGO HEADQUARTERS (Continued from page 69)

trade and through them the owners of machines become acquainted with its merits. "Once the customer learns how to use the Repointer properly he becomes very enthusiastic regarding its use," said President F. D. Hall, "and we have received many letters telling us of the improved tone produced through its use and that the needle repointed with our device reproduces the record better than when it is taken straight from the package. The principle on which this Repointer was made is becoming recognized as the correct one. It is the natural method. Anything that is to be pointed is shaved on the side like a lead pencil. The machinist in grinding a tool grinds on the side. This method not only saves the needle, but produces a most perfect point." The company's letter files are becoming crowded with letters from both dealers and users testifying to the satisfaction of the B. & H. Repointer.

Increasing Price of Magnola Talking Machines

The demand for the Magnola talking machine in all styles is not only increasing steadily, but continues to tax quite seriously the facilities of the company's large plant. Such persistent demand is of course gratifying, although the equally persistent rise in cost of production militates against the otherwise perfect happiness that would reign in the Magnola offices.

President Otto Schulz has recently been obliged to notify his dealers of increases in the retail prices of Magnola styles. Magnola 65 is now to retail at \$75, Magnola 85 now retails at \$100, Magnola 100 at \$125 and Magnola 150 at \$175. Wholesale discounts remain as liberal as before, so that this general raising of prices will enable Magnola dealers to sell at a better profit. This action is forced upon the Magnola Talking Machine Co. by pressure of actual manufacturing conditions and is quite in line with the policy of other leading manufacturers.

Magnola is now produced in seven styles, ranging from the moderate priced Magnola 75 to the elaborate and beautiful Magnola 200, in pure Adam style, with veneers, hardware and finish equal to that of the finest piano, with extra large and powerful motor, sound-box and tone chamber. All Magnola models, save the lowest priced, have the vertical filing cabinet built in, for record-filing, while all styles without exception have universal sound box playing all makes of record, tone-graduator for controlling loudness at will and tone wave deflecting system in tone chamber for assuring clear reproduction.

The handsome Magnola catalog, illustrated in colors, has proved to be a potent sales maker among prospective purchasers and copies of it will be mailed to any dealer who would like to see what good sales helps the Magnola Talking Machine Co. supplies to its retail representatives.

Magnola is now in its third year of continuous production and has been thoroughly tested in respect of all its special constructional features. The company is controlled by the stockholders of the famous M. Schulz Co., manufacturers of the famous M. Schulz Co. pianos and player-pianos, of which more than 130,000 have been made and sold. The M. Schulz Co., founded in 1869, is one of the most powerful factors in the music trade of the Middle West.

A Seasonable Cognomen

Wm. E. Cotter, manager of the talking machine department of Thos. E. Wilson & Co., is very jubilant over the advent of a new small daughter at his home last month. She will be known as "June," after the month of her birth.

A Splendid Showing

A visit to the factory of the Chicago Hinged Cover Support & Balance Co., 2242 West Sixty-ninth street, the other day, found the officers in charge of its destinies very well satisfied with the situation as viewed from their standpoint. The Chicago cover balance is the original device of the kind and its remarkable progress since it was first put on the market about two and a half years ago is shown by the fact that no less than

seventy-four manufacturers of talking machines are regularly using it on their product.

The company foresaw the present conditions in the material market and provided against them. They have a stock of steel on hand sufficient to take care of their normal demands for many months to come.

J. L. Abbott, manager, has just received the conventional post card announcing that his son, Russell Abbott, who was very recently in training at Ft. Sam Houston, San Antonio, Tex., has arrived safely in France. He is a corporal in the quartermaster's department.

Tells of Prosperity in the South

Westervelt Terhune, manager of the Columbia Graphophone Co.'s wholesale branch at Atlanta, Ga., was a caller on the Chicago trade this week. "One who has not actually studied conditions existing in the Southern trade at present," stated Mr. Terhune, "cannot conceive of the wonderful proportions to which it has grown within the past year. The tremendous amount of war work going on down South,

combined with the large crops of last year, has been a great stimulus to the Southern trade and they have plenty of money and are spending it. We anticipate a very favorable fall and winter season in the South, which is based upon the Government's statistical reports that the cotton crop will be next to the biggest one ever picked in the South. The biggest cotton crop we ever had down there was in 1914, but the increased prices that growers are getting for their cotton this year will make the coming crop far overshadow the receipts of 1914.

W. W. Wilson Visits

W. W. Wilson, manager of the educational department of the Columbia Graphophone Co., New York, was a visitor to Chicago recently. While here Mr. Wilson spent several days in conference with the salesmen of the Chicago branch and held a number of interesting meetings during which new and improved educational features were advanced for the benefit of the dealer handling the Columbia line.

(Continued on page 72)

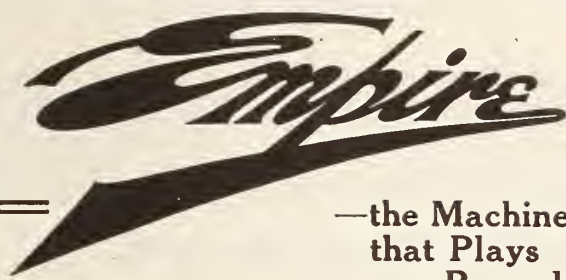

—the Machine that Plays any Record

It will pay you to look into this popular line of Talking Machines. The Empire Talking Machine has every worth while feature of all other makes in addition to several exclusive features. Dominates all others in perfection of tonal quality and sales value.



Model A 1
Price \$150.00

The Empire stands second to none in design and finish and enables you to meet the tastes and requirements of every buyer. Made in eleven models, prices at retail from \$32.50 to \$500.00.

We also make a line of Empire records which retail at popular prices. These are vertical cut records and are played with the reproducer in the vertical position. Selections consist of popular vocal and instrumental and high class grand opera numbers.

EMPIRE RECORDS
RETAIL AT
POPULAR PRICES



Ask Us
for a
"Dorothy Booklet"

Write today for our complete catalogs of Empire Machines and Empire Records, and full information regarding our Splendid Dealer Helps

Empire Talking Machine Co.

JOHN H. STEINMETZ, President

429 South Wabash Avenue

Chicago, Ill.

FROM OUR CHICAGO HEADQUARTERS—(Continued from page 71)

G. C. Vining With Columbia

Geo. C. Vining, one of the oldest members of the Chicago trade in length of service, is now connected with the Chicago branch of the Columbia Co. in the capacity of assistant to C. F. Baer. He succeeds R. C. Peere, who a few months ago was transferred from the Columbia Kansas City office to Chicago, Mr. Peere having gone back to the Kansas City branch. The change was made necessary owing to the ill health of Mr. Peere's wife. Mr. Vining is one of the "old land marks" in the Chicago trade, having started his career with the W. W. Kimball Co. in 1885.

Traveling Men on Vacation

H. L. Woodward, H. H. Michael and V. K. Tremblett, all travelers for the Chicago Talking Machine Co., are spending the month of July rusticated at Clear Lake, Iowa, where they have taken a cottage. The party was accompanied by Mrs. Woodward and golfing and swimming will be the main features of the event. Mr. Woodward travels Iowa and Wisconsin

for the company, Mr. Michael covers Michigan and Indiana, while Mr. Tremblett looks after the Illinois trade.

G. P. Ellis, sales manager of the Talking Machine Co., E. A. Garard, of Powell, Garard & Co., brokers, and Charles J. Tressler, general attorney for Swift & Co., packers, have taken the Gray cottage at Grand Beach, Mich., for several weeks. The three gentlemen, accompanied by their wives, will leave Chicago, July 20, and will indulge in golfing and bathing.

OkeH Records in Demand

S. A. Ribolla, manager of the Central States division of the Otto Heineman Supply Co., stated that the past month of business has kept him on the go continually from morning until night. "We are having an unusually heavy demand for motors, tone arms and supply parts from this division," said he, "and there is a rapidly growing demand for our new OkeH records. These new records are of the hill and dale cut, ten-inch, double-face and can be played with a steel or sapphire ball point. We have received our

Equip Your Phonographs With Perfect Automatic Brakes

Samples
\$1.00 Each
Cash with order

State make
of tone arm used



Also made
with long
brake shoe
for 1 inch
offset

Patented Aug. 28, '17

Simple construction and easily attached.
Made in four styles to fit any make of tone arm.

Write for attractive quantity price

PERFECT AUTOMATIC BRAKE CO.
Room 400, 425 S. Wabash Ave., Chicago

Phonographs and Equipment

Phonograph Value is based on the
Standard of Equipment used

Realizing the truth of this statement and what it means to the dealer and his future success,

Hiawatha Phonographs

are equipped with the highest standard of construction, of *Motor, Tone Arm and Reproducer*, which conform with the *beautiful cabinet and artistic lines* of the **Hiawatha**.

Hiawatha Phonographs enable the dealer to put his stamp of approval on each sale and be assured of only the normal percentage of mechanical trouble, which will result in a satisfied customer and increased business.

The **Hiawatha** is made in four attractive models, retail priced at \$40, \$65, \$115 and \$175.



Style 100

Hiawatha Phonograph Company

209 South State Street
CHICAGO, ILL.

advance bulletin which shows a selection of thirty numbers, and we understand from headquarters that we can expect an increase of at least fifteen numbers each month. As yet we cannot supply the trade from this office for the new records, but expect to be in a position to do so within a few weeks." P. L. Baerwold, who formerly was Eastern sales manager for the Otto Heineman Phonograph Supply Co., has been transferred to the Chicago office where he will assist Mr. Ribolla.

Adds Columbia Record Library

The talking machine department of the A. M. Rothschild department store has added a Columbia record library to its department. This store has handled Columbia machines for several years, but never handled the records. Manager George Israel stated that they are enjoying a brisk business in his department and that there is a tremendous demand for popular numbers.

Sergeant Denig to France

Sergeant Geo. F. Denig, who was formerly connected with the Chicago Talking Machine Co., sailed for France with his contingent on June 28. After enlisting in the service Sergeant Denig was stationed with Hospital Unit 14 for a period covering about four months at Camp Dodge, Ia.

"Does It Play All Records?"

Certainly **MAGNOLA** does; and without any extra attachments, too. This is only one feature, albeit a most important one, in the thoroughly up-to-date equipment of the **MARVELOUS MAGNOLA**.

MAGNOLA "Built by Tone Specialists"



Watching the Music Come Out

May we send you our *handsome illustrated catalog* chock full of information concerning the wonderful construction system of *Magnola* and the beauties of its musical results, its artistic appearance and its moderate price?

Send your name and let us tell you more!

MAGNOLA TALKING MACHINE COMPANY

OTTO SCHULZ, President

General Offices 711 MILWAUKEE AVENUE CHICAGO
Southern Wholesale Branch 1530 CANDLER BLDG. ATLANTA, GA.

FROM OUR CHICAGO HEADQUARTERS—(Continued from page 72)

In Service at the Front

Ray Orwig, Frank Johnson and Clarence Britton, three of the boys who were formerly connected with the various departments of the Talking Machine Shop, are now fighting at the front in France. In all there are seven members of the Talking Machine Shop now in the service. Four still are here in training, but only too anxious to get over with their fellow workers in order to get a crack at the Hun.

Wiswell on Trade Conditions

L. C. Wiswell, manager of the Victor department of Lyon & Healy, made a short trip to Pittsburgh last week in order to make a comparison with the business conditions of both Pittsburgh and Chicago. "I made a round of the houses in Pittsburgh and since coming home I have visited a number of places here in Chicago and I find that the conditions of both cities are very similar. The machine situation has eased a little and records are in big demand. The retail business is fair, but the wholesale is slowed down a little. There is nothing to worry about, however, as regards the business of the past month for an investigation of the records shows that the business carried on was practically the same as last year."

Makes Good Connections

G. W. Fricke, treasurer of the Lakeside Supply Co., stated that he made several excellent connections for both mica diaphragms and sapphire needles. He is now in a position to take care of the trade and supply its wants for mica diaphragms in all sizes and any quantity. The connection made for the jewel needles, which, by the way, are both sapphire and diamond point, was made with one of the largest lapidaries, making these articles in this country. Mr. Fricke also stated that they are filling a great number of orders for their new one position tone arm and that the Lakeside rotometer is in great demand.

Cash Business Only

Harry Martin, of Kohoka, Mo., who is the Victor dealer of that town and also handles a line of well-known pianos and players, was a recent Chicago visitor. Mr. Martin stated that he is enjoying a very good trade in his town and is selling his talking machines out for cash only, and has no trouble in getting away with it.

The New Hiawatha

The Hiawatha Phonograph Co. made their first shipments the latter part of last week from the new factory at Geneva, Ill. Sales Manager Moynahan states that they are highly pleased with the facilities offered by the new plant which, in many respects, are far in advance of those of the old factory at Ottawa, Ill. While the styles and models remain practically the same, there have been numerous minor changes in design, which in the aggregate add considerably to the appearance and value of the machine.

In response to the demand in their trade for a large machine built on the massive order they now have in work a new model which will be ready for shipment in ten days. It will be fifteen inches in height, exceptionally attractive design and will retail at \$175. The other Hiawatha models retail respectively at \$40, \$65, \$85 and \$115. The new addition they now have enables the dealer to supply a machine for every pocket.

Automatic Container Co.'s Display

The Automatic Container Co. have their entire line of record containers on display in the Furniture Manufacturers' Exhibition Building at 1319 Michigan avenue. The furniture manufacturers hold their exhibitions in this building semi-annually during the entire months of both July and January. These exhibits are always well attended by the furniture dealers from all over the United States, and full and complete lines of all kinds of household furniture are shown. The Automatic Container's exhibit occupies a large space on the third floor of this building, which by the way is the main one, there being two other exhibitions used in conjunction with this one, the other buildings being located a few blocks away.

Six Best Sellers for the Month

Edison announces the six best sellers for the month as follows: "Elegie" and "O Solo Mio (My Sunshine)"; "O Dry Those Tears!" and "Oft in the Stilly Night"; "Somewhere in France is the Lily" and "When Johnny Marches Away"; "Johnson 'Jazz Blues'" and "Umbrellas to Mend"; "Darktown Strutters' Ball" and "They Go Wild, Simply Wild, Over Me"; "U. S. Army Camp Songs."

The Pathé six best sellers for the month are: "Ten Little Bridesmaids" and "Stop, Look and Listen"; "Fancy You Fancying Me" and "The Further It is From Tipperary"; "His Wonderful Irish Brogue" and "Do You Want Us to Lose the War"; "Hawaiian Nights" and "Somewhere in Hawaii"; "Our Country is in it Now" and "Your Lips are No-Man's Land but Mine"; "Lights Out" and "Liberty Lads."

The six best Columbia sellers for the month are: "Just a Baby's Prayer at Twilight" and "Fancy You Fancying Me"; "Regretful Blues" and "Ev'rybody's Crazy 'Bout the Doggone

Blues but I'm Happy"; "The Story Book Ball" and "Musical Sam From Alabam"; "Just Like Washington Crossed the Delaware (General Pershing Will Cross the Rhine)" and "What Are You Going to Do to Help the Boys"; "There's a Little Blue Star in the Window" and "Mammy's Little Pansy"; "We Stopped Them at the Marne" and "Hike! Hike! Hike!"

Emerson announces the best sellers as follows: "The Russians Were Rushin'; The Yanks Started Yankin'" and "We Stopped Them at the Marne"; "They Were All Out of Step But Jim" and "'N' Everything"; "The Last Long Mile" and "A Little Bit of Sunshine from Home"; "Take Me Back to Dear Old Blighty" and "Keep the Home Fires Burning"; "There's A Long, Long Trail" and "The Missouri Waltz"; "National Emblem" and "Gate City."

The six best Victor sellers for the month are: "The War Baby's Lullaby"; "Little Mother of Mine"; "The Volunteers" (March) and "Liberty Forever" (March); "Your Lips are No
(Continued on page 74)



TONE ARM and REPRODUCER



Has Honestly Earned Its Reputation for the Exceptional Quality, Purity, Clearness and Sweetness of Its Tone.



Showing the Empire Reproducer turned back to permit insertion of needle



Showing the Empire Tone Arm set in position for playing vertical cut records

It is adjustable to any position without the use of set screws and the convenience of its throw-back position for inserting the needle will make an extra appeal to the retail purchaser.



Patent Applied For

Plays Any Make Record

The wonderful quality of its tone will add to the distinction of any machine.

The Empire Tone Arm and Reproducer can be furnished in several lengths. When ordering samples be sure to state the measurements from center of turn table to center of horn hole on motor board.

This company is directed by men who have spent years in the production and marketing of phonograph parts, and know from actual experience how to produce the kind of tone arm and reproducer most suitable from the dealer's and consumer's standpoint. Our tone arms will increase your talking machine sales as they are given preference by the consumer, which means more profits for you.

Write our Chicago Office for Descriptive Circular and Quotations

THE EMPIRE PHONO PARTS COMPANY

Sales Office: 427 So. Wabash Ave. - - Chicago, Ill.
Factory: - - - 1102 W. 9th St., Cleveland, Ohio

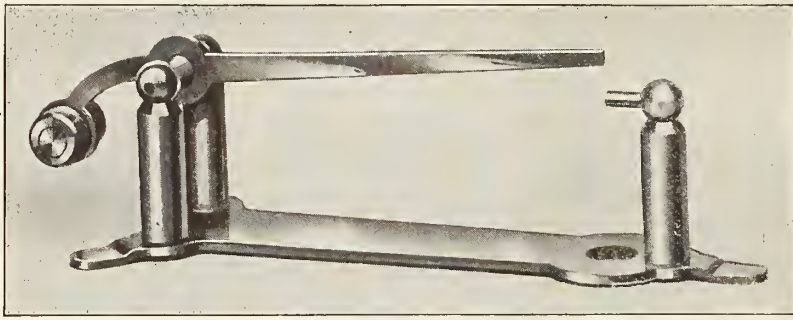

(Actual Size)

Lakeside Rotometer. Retail Price \$2.50

Calibrated so swinging arm is level with pointer at 78 or 80 revolutions per minute. Patents Pending.

We have a large quantity of both Edison and Pathe Sapphire Needles. Write for prices. We can supply you with first-grade, clear Brazilian Micas, any size, any quantity.

LAKESIDE SUPPLY CO., Inc.
202 South Clark Street Tel. Harrison 3840 CHICAGO, Ill.

NOW PLAYS ALL RECORDS IN ONE POSITION
J U M B O N A O. A R M 4

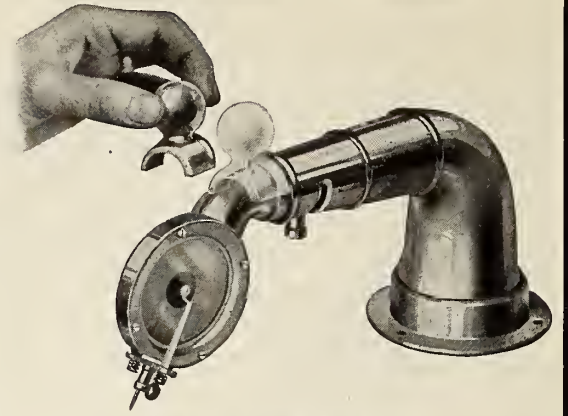

RETAIL PRICE \$7.50 EACH
Prices to Bona Fide Dealers

Sample	\$4.00 each
Lots of 6 to 11	3.75 each
Lots of 12 to 49	3.50 each
Lots of 50 to 100	3.25 each

A further slight reduction on yearly contracts in 100 minimum lot shipments
PATENTS APPLIED FOR

FROM OUR CHICAGO HEADQUARTERS—(Continued from page 73)

Man's Land But Mine" and "Our Country's In It Now"; "What Are You Going to do to Help the Boys" and "Keep Your Head Down, Fritzie Boy"; "From the North, South, East and West" (Lauder).

Will Embark for France

George B. Wiswell, secretary of the West Music House, Joliet, Ill., has offered his services as war secretary to the Y. M. C. A. for overseas duty in France, and he has been accepted. He reports at the overseas headquarters in New York for duty on August 5, and expects to leave for the war zone immediately. Mrs. Wiswell and her child will reside with her mother at Pana, Ill., until Mr. Wiswell returns.

New Puritan Sales Manager

Irving B. Tow, formerly of the Geo. P. Bent Co., is now connected with the firm of James B. Orth & Co., factory distributors of the Puritan phonographs and records as sales manager.

This company was recently made jobbers for the Paramount records and expect to have quite a large stock of these new records on hand very shortly.

John Pishotta, who also was formerly connected with the Bent Co., as secretary to Still R. Harcourt, manager of the retail piano department, is also with James B. Orth & Co. as secretary to Mr. Orth.

Visitors and Personals

Geo. Wiswell, of the West Music Co., Joliet, Ill., a brother to L. C. Wiswell, manager of both the wholesale and retail Victor departments of Lyon & Healy, was a visitor to Chicago this week.

L. R. Weager, Illinois traveler for the Victor Co., is spending about three weeks calling on the Chicago trade, after which time he will return to the Victor factory at Camden.

C. F. Baer, assistant manager of the Chicago

office of the Columbia Graphophone Co., is spending a week with his family at his summer home at Lake Catherine, Antioch, Ill. As is customary at this time of the year Mr. Baer anticipates spending the week-end vacations with his family at Lake Catherine and returning to his office each Monday morning.

H. S. Leavitt, of the Howard Furniture Co., St. Paul, Minn., called on the Chicago trade this week.

D. M. Groulx, of Green Bay, Wis., was a recent visitor here.

C. M. Crandall, of Scott & Crandall, Fremont, Mich., recently visited Chicago for several days.

Fred Sherman, of Sherman, Clay & Co., San Francisco, was a recent caller on the Chicago trade. Mr. Sherman had been in the East and was en route to headquarters at 'Frisco.

C. L. Bryant, manager of Gregory's Music House, Saginaw, Mich., spent a few days in Chicago recently.

Geo. P. Cheatt, proprietor of the Music Shop, Springfield, Ill., was in Chicago recently, having just returned from a week's Eastern trip.

Robert Elbel, of Elbel Bros., South Bend, Ind., was in Chicago last week on business.

H. H. McCLANAHAN KILLED

Victor Talking Machine Traveler Killed in Airplane Accident

MEMPHIS, TENN., July 1.—Harvey H. McClanahan, of Lewisburg, Tenn., was killed last week in an airplane accident. He had been in training for the aviation service for several months and would have received his commission as a lieutenant on the 15th of July. Mr. McClanahan had been connected with the Houck Piano Co., of Nashville, Tenn., for a number of years and later acted as manager of the Grafonola department of the Phillips & Buttorff Co. Following that he became a traveling salesman for the Victor Talking Machine Co. and was working in Tennessee territory at the time of enlistment in the aviation section. He was about 30 years of age and is survived by a widow.

BRUNSWICK MAN WRITES SONG

St. Louis, Mo., July 5.—K. McInniss, who is manager of the wholesale phonograph division of the St. Louis branch of the Brunswick-Balke-Collender Co., has just written the words and music for a patriotic war song entitled, "I Love You, Canada." It is stated that this song, which was published some time ago, has made a tremendous hit in Canada, and that this fact was brought to the attention of the Pathé Frères Phonograph Co., and they decided to make recordings of it and introduce it to the music lovers of the United States. The new song will be presented in the August issue of the Pathé records. Mr. McInniss has written other popular and classical songs, and is very well known throughout the country as a music writer.

A Tonal Wonder

The Morenus Phonograph has won widespread recognition because of its unusual tonal quality. The novel all-wood horn which enters at the bottom (not the top) of the scientifically constructed tone chamber has proven itself astonishingly efficient in securing a most pleasing tone and a remarkably faithful reproduction of the record.

The Equipment is high grade in every respect, plays both types of records, has cover support setting top at any desired angle, original tone moderator, etc.

The Morenus cases are superb productions in every respect.

The MORENUS is in 3 STYLES

- A. OAK, - - 48 inches high. Retail price, \$110
- B. MAHOGANY, 48 " " " " 125
- C. OAK and MAHOGANY, 50 inches high, Retail price, - - - - 150

*Very liberal discounts to the trade
Send for our new descriptive catalog*



Style B

The MORENUS PIANO CO.
342 West Huron St. CHICAGO, ILL.

FROM OUR CHICAGO HEADQUARTERS—(Continued from page 74)

BEAUTIFUL EMPIRE ART MODEL

Art Instrument of Queen Anne Design Made by Empire Talking Machine Co. Wins Praise

CHICAGO, ILL., July 8.—The Empire Talking Machine Co. now have on display in their ware-rooms at 429 South Wabash avenue one of their new Empire art model period style talking machines of the Queen Anne design. This new instruments, which by the way, was announced to the trade in the news columns of The World last month, is the first of the type to be produced at the Empire plant and is of genuine mahogany, the dimensions being length, 55 inches; width, 25½ inches, and height, 40 inches. The accompanying illustration shows very clearly the delicate and artistic beauty of the hand-carved decorations and grill. The workmanship is of the fine quality which is characteristic of all Empire instruments. This new model is fitted with two secret doors, which are placed above the record containers. The patent cover supports as well as all exposed metal parts are gold

plated. It is equipped with a high-grade electric motor and gold plated Empire tone arm, reproducer and automatic stop. The supplies



Art Model Empire—Queen Anne Design furnished with the Queen Anne model are a diamond jewel needle for Edison records and a sapphire ball point for playing both Pathé and

Empire records. A leather packed velvet Empire record cleaner as well as a full set of record albums are also supplied. It is announced by the Empire Co. that machines of this type will be furnished in three woods, either mahogany, walnut or oak, and can be had only upon special order. The retail list price is \$500.

ANNOUNCE THE NIGHTINGALE, JR.

Attractive Addition to Their Phonograph Line Announced by the Nightingale Mfg. Co., Chicago—Equipment Used is of the Best

CHICAGO, ILL., July 8.—The Nightingale Mfg. Co., of 422 North Armour street, this city, announce the Nightingale Junior, an attractive addition to their line of Nightingale phonographs. In design it follows the general lines of the style 200, which is illustrated in the company's page advertisement elsewhere in this issue. It is forty-four inches in height, nineteen inches wide and twenty inches deep. It can be fur-

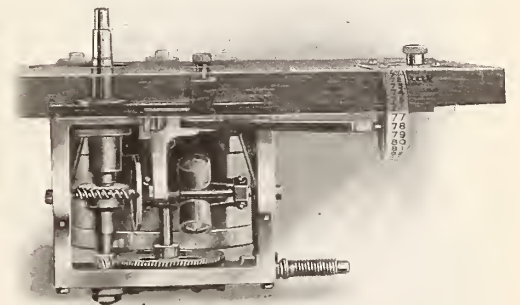

Stephenson Motor Used in the Nightingale finished either in black walnut, American Circassian walnut, regular mahogany, antique brown mahogany and the three favored oak finishes, golden, fumed and waxed oak. Like the other Nightingale models it is equipped with the Stephenson precision-made motor, a fact which assures dealers handling the line the minimum of motor troubles, and an assurance of satisfaction on the part of the dealers.

"From the commencement of our business," said Mr. Wolper, the president, in a talk with The World, "we have gone on the principle that nothing is too good for the Nightingale, and we have endeavored both in the selection of equipment and in the construction and building of the cabinets, which, by the way, are made entirely in our factory, to spare no expense in producing a machine that will add prestige to the dealer and secure for him increasing and permanently profitable patronage."

Mr. Wolper recently returned from an eastern trip during which he not only secured some excellent orders from established dealers but made some very desirable new accounts.

MUSIC HAS AN HYGIENIC VALUE

Well-Known Physician Declares Melody Is a Prophylactic Against Depression

Dr. Nathan Gordon, of Local Board No. 157, New York, is a strong advocate of plenty of music for the soldiers, and recently sent a check for \$75 with which to purchase a machine for the Tank Corps at Camp Colt, Pa. In discussing the question of music and the soldier, Dr. Gordon said:

"There is no question whatever of the great hygienic value of music to the boys at the front in their scant hours of relaxation. Music is a prophylactic against depression and the anti-septic of the soul. It would prevent and cure a great many mental and physical ills among the soldiers."

MUSIC IS A MORAL LAW

Music is a moral law. It gives a soul to the universe, wings to the mind, flight to the imagination, a charm to sadness, gaiety and life to everything. It is the essence or order, and leads to all that is good, just and beautiful, of which it is the invisible but dazzling, passionate and eternal form.—Plato.

The **VITANOLA**

Combines: Popularity and Profit



Trade Mark Registered



The increasing popularity of the Vitanola with phonograph dealers is due to two primal reasons, viz.: a machine that gives absolute satisfaction—and agency proposition that is fair and liberal. These are the two essentials of any merchant's success with a talking machine. If the machine doesn't give satisfaction the merchant can't sell it at any profit, either to himself or the manufacturer. If the agency proposition isn't fair and liberal, the merchant can't afford to handle the machine. Some of our agencies make big money considering the amount of time they give to the Vitanola; anywhere from fifteen hundred to five thousand dollars per year.

You only need to hear the Vitanola to know that your customers will buy it. In tonal purity and absence of all foreign sounds—in exceptionally accurate and life-like reproductions of voice, the Vitanola is a marvel.

Seven Vitanola Models

\$25 to \$175

Vitanola Talking Machine Co.
501-509 West 35th Street :: Chicago, Ill.

Send for complete descriptive literature and Agency proposition

Another Seeburg Triumph!!

The Phono-Grand



Height 55 inches. Width 34 inches

NOT much larger than an ordinary talking machine cabinet but a combination of both a player piano and a talking machine.

The case design of the PHONO-GRAND is highly artistic and made in a number of beautiful designs to harmonize with the most artistic parlors and music rooms.

The player piano of the PHONO-GRAND is remarkable for its tone quality. It plays all regular 88-note player rolls and is especially adapted for the Q. R. S. Expression Rolls.

The talking machine of the PHONO-GRAND is of the highest type and plays all standard records either lateral or vertical cut.

Both instruments are controlled by separate electric motors. The compactness of the PHONO-GRAND permits its use in places that do not allow space enough for both a player piano and talking machine. The PHONO-GRAND is not an experiment but a demonstrated success.

J. P. SEEBURG PIANO CO.

Leader in the Automatic Field
REPUBLIC BLDG. CHICAGO

FROM OUR CHICAGO HEADQUARTERS—(Continued from page 75)

BRUNSWICK ADVERTISING SERVICE

Unusually Artistic Posters Just Gotten Out for Trade Which Should Prove of Value

CHICAGO, ILL., July 10.—The advertising department of the phonograph division of the Brunswick-Balke-Collender Co. is working full capacity in turning out new advertising service for their dealers. The latest addition to this service is a folder which contains cuts and list prices of the entire well-known Brunswick line, as well as several cuts showing the

new Ultona reproducer and Brunswick new all-wood tone amplifier. This is printed on a large sheet of paper on one side only and in such a way that when unfolded everything will be before the reader's eye without the bother of turning the folder either around or upside-down while being read.

Since the announcement was made some time ago that the Brunswick Co. was preparing for its dealers some large steel outdoor advertising signs numerous requests have been made for samples, and quite a number have already been sold. Orders for five hundred of the Brunswick Girls have already been received and sent out. This cut-out is a portrait of a very beautiful, life-sized young lady, in an attitude of rapture with hands clasped and so made that when used as a window decoration and placed before a Brunswick phonograph she appears to be looking down on the machine and listening. It is in colors and size five feet three inches tall and the appearance is very life-like and startling. The Brunswick Co. has made arrangements with the printers of the Brunswick Girl so that the dealer may have them for three dollars, which, by the way, is but half the price, the Brunswick Co. paying the other three dollars.



Brunswick Girl Poster

The big steel signs, ten by twenty-eight inches, which are offered to the dealer at a price of twenty-five dollars a hundred, are also in demand and orders have been taken for seventy-five hundred of these at present. These signs are steel backed and lithographed, not painted, in colors with embossed lettering. The colors are baked on, thereby making the signs weather-proof and permanent. The big sign has holes punched in it so that it can be nailed on any suitable surface or fastened to a wire fence. The type is bold and can be easily read more

One of the Brunswick Steel Signs



Plays All Records

JUST YOU HEAR
The
Brunswick
ALL PHONOGRAPHS IN ONE
DEALERS NAME AND TOWN

than one hundred feet away. The dealer's name and location is printed in black at bottom.

SALESWOMAN GUESSED WRONG

Stuttering Customer Was Not Impressed With Rendition of "K-K-K-Katie"

PORTLAND, ORE., July 5.—The other day a man and a woman entered the talking machine department of the Wiley B. Allen store and when Mrs. Olga Binder, in charge of the record department, approached them the woman said they wanted some records, but would first like to hear some before making selections. The man, meantime, remained silent. Mrs. Binder asked what was preferred and the woman replied: "Something funny."

So Miss Binder put the popular trench stuttering song "K-K-K-Katie" on the machine. An ominous, disappointing silence followed the rendition of the song for a few moments. Then the man said:

"I-I-I d-d-d-don't l-l-like tha-that re-re-record."

They bought some others, however, but no stuttering ones.

TAKES CHARGE IN SPRINGFIELD

Manager Hornberger, formerly of the talking machine department at the McAlpin department stores in Cincinnati, has resigned to accept the management of the Columbia department recently installed in the Wren department store at Springfield. Mr. Hornberger is well known in talking machine circles, and has every prospect of making a good showing at Springfield. The Edw. Wren Co. conduct the largest department store in Springfield and one of the best equipped in the State.

Mary Pickford has provided eight talking machines for Y. M. C. A. huts and two for the K. of C. clubhouse at Camp Kearney, Cal.—gifts which are much appreciated.

The OROTUND and SUPERIOR

Attachments, Tone Arms and Velvet Running Jewel Points

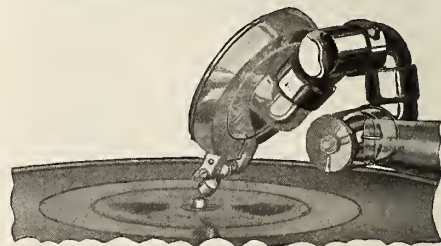

If you want to play the wonderful new Edison and Pathe records with the least amount of surface sounds and produce the best quality of music, you should use the Superior and Orotund attachments made to fit the Edison, Victor and Columbia machines.

Do not forget our attachments will not damage records when operated according to instructions. The cut shows our universal attachment used to play all makes of records on the Victor machine.

IMPORTANT

In ordering samples please state the kind of finish wanted, viz.: nickel or gold, also describe the tone arm, old or new.

Write for quantity prices and descriptive circulars.

COMBINATION ATTACHMENT CO.
20 Jackson Boulevard, East, Chicago, Ill.

MEETING OF PORTLAND ASSOCIATION

Dealers Collecting Used Records for Soldiers—Discuss Interest Question and the Benefits of the Organization—Agree to Early Closing

PORTLAND, ORE., July 5.—Twenty-seven members were present at the June meeting of the Portland Talking Machine Dealers' Association at which a business meeting and banquet brought forth some interesting trade chat and paved the way for an entirely new patriotic movement.

L. D. Heater, manager of the Columbia Graphophone Co., made the suggestion that all dealers should endeavor to obtain used records from customers for the soldiers at the Post Hospital, Vancouver Barracks, Wash. Mr. Heater told of visiting the hospital and learning from the soldiers that they are tired to death of hearing the tunes played and replayed from the few records they have and they begged for a few new ones. Mr. Heater suggested placing boxes in the windows of the stores with labels calling for donations. E. B. Hyatt, president of the association, was a warm advocate of Mr. Heater's plan and he asked all the dealers to give it their hearty support. All present said they would do everything possible to help, and since the meeting every store in Portland handling talking machines has had a window devoted to this cause and donations have been remarkable.

One of the dealers declared this week that the movement has actually resulted in a big increase in business because customers have been bringing in records of which they were tired, placing them in the box for the soldiers and then buying new ones for use at home.

Some interesting data was given on interest charges, dealers who have taken up the practice reporting that the plan is working out far better than they expected. A committee which had been appointed to interview all the dealers relative to early closing on Saturday evenings reported that the plan had been adopted by all the music dealers in Portland.

President Hyatt made a short talk on the advantages of the association, pointing out that in little more than a year the membership had grown to a point where it embraces virtually every house in Portland. He placed stress on the kindly feeling which has grown up among the various houses of the city as a result of the association. The keen, bitter rivalry of former years seems to have passed, Mr. Hyatt said, and has been replaced by a sort of get together spirit in which the trade has been greatly benefited. The monthly meetings have done much to aid the business and the president pointed out many of the material advantages which have resulted, including increase in initial payments, doing away with letting records out on approval, early closing on Saturday, interest on deferred payments, etc.

CARUSO IN MOVING PICTURE FIELD

Enrico Caruso, the great operatic tenor, whose Victor records are universally popular, has at last signed a contract with the Famous Players-Lasky Corporation and will start to work on his first picture, which is to be an Arctcraft production, about the middle of the month. Jesse L. Lasky announces that it will not be a screen version of some opera, as was supposed, but an original story written especially for the tenor. It will be filmed in New York or Fort Lee. Caruso is expected to make two pictures this summer.

RECOVERING FROM OPERATION

Adolf Heineman, assistant general manager of the Otto Heineman Phonograph Supply Co., New York, is recovering at Mt. Sinai Hospital after a series of minor operations. During his stay at the hospital Mr. Heineman has received telegrams and letters from his many friends in the trade throughout the country, who trust that this popular "veteran" will soon return to his desk and take charge of the many activities under his direction.

TALKING MACHINE AIDS GUNNERS

Popular Airs Ground Out to Cheer Men While They Fought the Foe

A despatch to the New York papers from "An Atlantic Port" under date of July 6 says: "Conducting artillery fire to the accompaniment of popular airs played on a talking machine is one of the latest stunts engaged in by the Yankees on the American front in France.

"This was the statement to-day of Lieutenant-Colonel Thomas Stanyan, of the Salvation Army, on his arrival from France, where he was sent on a special mission by Commander Booth.

"He visited and inspected every hut and dug-out occupied by Salvationists, covering 1,000 miles in an automobile in nine days.

"Commandant Hughes, of Akron, O., was in a dugout playing a machine to the six men of a gun crew," said Stanyan, "when the order came to shell the German line. The men rushed out, calling to Hughes to bring along the machine.

"Hughes complied. While the men worked the gun Hughes ground out popular airs with the machine perched on a stump. A gas shell spoiled the program. Hughes, brave, but not cautious, was gassed and is now in a hospital."

VOCALION CHANGE IN PROVIDENCE

Tilden-Thurber Corp. in That City Takes Over Local Vocalion Co. and Opens Special Department for Featuring That Line

PROVIDENCE, R. I., July 8.—The Tilden-Thurber Corp., of this city, has taken over the business of the Vocalion Co. and will open a separate department devoted exclusively to the Aeolian-Vocalion phonograph and the new Vocalion records. The Vocalion Co., which operated its branch in Providence from the main New England store in Boston, has retired from the field in this city; but the Vocalion products will receive splendid representation in the warerooms of the Tilden-Thurber Corp. This company is one of the best-known retail houses in New England, and will institute an aggressive campaign in behalf of Vocalion products.

Thos. W. Hindley, who has been manager at Vocalion Hall since last winter, will join the traveling staff of the Vocalion Co. in Boston, with headquarters in that city. The Tilden-Thurber Corp. will take over all the contracts, etc., made by the Vocalion Co., and will continue collections and the other detail work incidental to the business.

LOUISVILLE DEALERS ORGANIZE

Talking Machine Retailers Form New Association at Meeting on July 2

LOUISVILLE, KY., July 5.—The launching of the Talking Machine Dealers' Association of Louisville was accomplished with great enthusiasm at a meeting on July 2 at the Hotel Watterson, when most all the dealers in the city turned out and enjoyed a pleasant dinner together. Everyone became better acquainted and good fellowship seemed to be the spirit of the meeting, while problems of mutual interest were discussed.

The officers of the association are B. L. Loventhal, of the Grafanola Co., president; W. A. Frank, of J. Bacon & Sons, secretary; J. S. Calveard, of the La Harmonie Co., vice-president; G. A. Shafer, of Stewart Dry Goods Co., treasurer. The following appointments were made by the president: C. A. Taylor, of Taylor & Gaber Co., chairman of executive committee; H. V. Boswell, of Kaufman-Straus Co., chairman of press and publicity committee; H. Korte, of Herman-Straus Co., chairman of grievance committee.

Firms in New Albany and Jeffersonville and other adjacent localities to Louisville have come into the association, thus greatly widening its influence. These dealers have organized with a desire for friendly acquaintanceship and a free and frank interchange of ideas for the advancement and development of their respective business, so that the interests of each individual member will be promoted. It is estimated that much good is going to be derived from the many subjects that will be brought up at the next meeting to be held Tuesday, July 16, 12:30 noon, at the Hotel Watterson.

JOINS CANADIAN SALES FORCE

A. E. Landon, formerly assistant manager of the Philadelphia branch of the Columbia Co., has been appointed a member of the Columbia Canadian wholesale organization, with headquarters in Toronto. Mr. Landon will work under the direction of James P. Bradt, general manager of the Columbia Co.'s Canadian interests, and judging from his success as a member of the Columbia sales staff, he will be a welcome addition to the Canadian organization.

O. M. Adams has opened a new music store at Marysville, Kans., handling Brunswick phonographs and Holland pianos

THE VEECO WAY

Takes all the Uncertainty out of the ELECTRIC OPERATION OF TALKING MACHINES

The improved VEECO electric motor is designed primarily and exclusively for Talking Machines. It is smooth and noiseless in action and practically fool-proof. Standard models run on any voltage from 100-125, A. C. or D. C., without adjustment. Other models for any voltage from 6-250. Furnished mounted on 12 or 12½ inch mahogany board ready to install, or without board, all ready to mount on such board as used by the manufacturer.

With the VITRALOID turntable, supplied with the motor, it makes a complete motor unit for high class machines.

Send for a sample NOW and place your order at once for early fall delivery.

THE VEECO COMPANY

248 Boylston St.

Boston, Mass.

THE ORIGINAL PRODUCERS OF A COMPLETE ELECTRIC DRIVE FOR TALKING MACHINE MANUFACTURERS' USE



"Take a Grafonola with you"

—A mighty potent argument this Summer. Use it for all it is worth.

**Columbia Graphophone Co.
NEW YORK**

VISITORS EXPRESS APPRECIATION

Enthusiastic Over Merits of OkeH Records Made by Otto Heineman Phonograph Supply Co.—Hadley Symphony Orchestra to Make Records—Motor Orders Received in Large Quantities—Unusual Demand for Needles

"During the past few weeks we have received visits from many well-known talking machine jobbers and dealers in different parts of the country, who called at our offices and laboratories to investigate our 'OkeH' record," said Otto Heineman, president of the Otto Heineman Phonograph Supply Co., in a chat with The World. "These callers have included record experts and recognized authorities, who inspected every minute detail of the 'OkeH' record before passing judgment on our product.

"I am pleased to say that without a single exception, members of the trade have expressed their entire satisfaction and approval of the 'OkeH' record. They have commented particularly upon the fact that the surface noise on this record had been reduced to a minimum, and have expressed pleasure at the list of well-known artists which are recording for our library. Our record manufacturing plant is now in full operation, and judging from the orders already received this factory will be obliged to work to capacity throughout the year to keep pace with the demand.

"We have endeavored to record selections that will not only appeal to the popular taste, but will also meet with the approval of discriminating and critical music-lovers and musicians. In other words, we will strive to give the public a 75-cent record that, in addition to a library of popular music, will comprise a repertoire of standard compositions of recognized musical merit and quality. With this object in view, we have arranged to have records made by well-known string quartets, etc., and will also include in our library symphonic records made by the Hadley Symphony Orchestra conducted by Henry Hadley, who is very well known in the concert and musical worlds. Incidentally, this orchestra is under contract to make records for our company exclusively. We will also present in the 'OkeH' record lists, 'cello solos, piano solos and orchestra selections, which we are sure will meet with popular favor.

"We have received large orders during the

past fortnight for our motors, tone arms and sound boxes from phonograph manufacturers throughout the country, and in view of these orders, I believe that the phonograph business in this country is going through the same experience as England and Canada did during the early part of the present war. It seems that during wartimes there is created a tremendous



Otto Heineman at His Desk

demand for phonographs and records, which are recognized as the most satisfactory home entertainment during such days, while for the boys in the camp and in the trenches they are becoming more in demand day by day, and they are being sent abroad and to the cantonments in large quantities.

"As announced last month we have restricted the production of our motors in order to co-operate with the Government from a labor standpoint, and in order to use less raw material. We find that this curtailment has met with the general approval of our trade, and we are concentrating our activities on the production of Heineman and Meisselbach motors, tone arms and sound boxes along efficient lines that we hope will give our clients satisfactory service and at the same time enable us to co-operate with the Government's requirements.

"As far as the Dean talking-machine needle

situation is concerned, I hope that our customers will continue to be as patient and forbearing as they have been in the past, especially in view of the fact that we are turning out large quantities of textile pins, comb, faller, feeder and card pins for the United States Government. This work has been going on at the Dean factories in Putnam, Conn., since the war started,

and is continuing with unabated energy. Of course our trade understands that these Government orders take precedence over all talking-machine needle requirements, but as our Newark plant has just started operation, we hope to be able to increase our needle output materially in the near future.

"I may mention that we received in the last week in June, the largest single needle order that I believe has been received by a needle manufacturer during the past few years. This order called for a vast amount of Dean steel needles and as it was received from a talking-machine company of international prestige, we consider it an unusual tribute to their merits."

AN INTERESTING NUMBER

The July issue of the "Columbia Record," the house organ published monthly by the Columbia Graphophone Co., made its appearance this week, and as usual contains many interesting and timely items for the use of dealers throughout the country. These items are based on the practical experiences of representatives and therefore furnish invaluable information for the development of Grafonola and record business. In this issue attention is called to several new moving picture slides that were recently prepared for the use of Columbia dealers, and there are the usual number of attractive window displays prepared by dealers in different sections. The service department contributes its quota of suggestions, which contain a summer appeal for the benefit of Columbia representatives.

WALTER S. GRAY

SAN FRANCISCO

NEEDLES

Pacific Coast Jobber for the Best in Talking Machine Trade Accessories

CHRONICLE BUILDING, SAN FRANCISCO

TALKING MACHINE AIDS PATRIOTISM OF CLEVELANDERS

Dealers Well in Evidence in Fourth of July Celebration—Intern German Records—What Leading Members of the Trade Report Regarding Business—Most Popular Record Sellers of Month

CLEVELAND, O., July 5.—The Fourth of July marked a new epoch in Cleveland patriotism in which music, and particularly talking machines and dealers in them, played an important role. The Fourth pageant was one of the longest and most spectacular ever seen in the city and its leading suburbs.

Talking machine dealers were well represented on all committees and the store decorations and displays of instruments, records, music rolls and other goods were never equaled in the city. The Eclipse Musical Co. and the Collister & Sayle Co. had especially attractive window displays.

During the Wagar Park dedicatory exercises in Lakewood the May Co.'s music department furnished the instruments used during an interesting program.

Talking machine dealers are still hoping that more goods will be available later along. The demand for machines and records was never so strong. Competition is very keen, but clean business methods mark the efforts of Cleveland dealers to market their stock, due in some measure to the influence of the Talking Machine Dealers' Association of Northern Ohio.

The Brunswick-Balke-Collender Co. reports a splendid trade in Brunswick phonographs, which have met with much success locally.

The Collister & Sayle Co., retailer of Victor records, reports a splendid June business, and the July start is equally as good, considering that music lovers are away from the city.

"Going as usual" is the way Charles K. Bennett, president of the Talking Machine Dealers' Association of Northern Ohio, speaks of his own business, that of the Eclipse Musical Co., of which he is general manager. "We are doing all we can to keep business up to standard because business going and not in a stagnant condition will aid in whipping the Kaiser and his Hun soldiers."

The B. Dreher's Sons Co. is making an attractive display of talking machines and records in the firm's Euclid avenue store. Henry Dreher is a great golf player, but he keeps one eye on his firm, which is one of the oldest and most progressive in Cleveland.

Practically all of the talking machine dealers have discarded the sale of records "interned" during the war period by the action of their association some weeks ago. Records which reproduce vocal or instrumental selections in the German language and those of pro-German artists are barred from sale. While the action took out of sale stock about 1,000 titles new records have taken the place of those barred from sale.

The Fischer Co., Pathé distributor, reports a good June business and prospects for splendid trade during July.

Among the most popular records of the month, judging from the public demand, are:

Columbia—"Ballet Music From Faust," by the Metropolitan Opera Orchestra; "Fancy You Fancying Me," by Edna White Trumpet Quartet; "We'll Do Our Share," by Robert Lewis; "What'll We Do With Him, Boys?" by the Peerless Quartet, and "Hike, Hike, Hike," by the same.

Pathé—"Calm as the Night," by Katherine Howard; "Whispering Hope," by Lilian Heyward and Louise Brentwood; "If He Can Fight Like He Can Love, Good Night Germany," by Arthur Fields; "They Were All Out of Step But Jim," by Constance Farber.

Victor—"I'm Sorry I Made You Cry," by Henry Burr; "Forget-Me-Not Waltz," by McKee Orchestra; "Freedom for All Forever," by Reginald Werrenrath, and "Gems Are Going Up," by John McCormack.

Starr—"Tell Me, Beautiful Maiden," by Frida Benneche, in French; "On the Road, Home, Sweet Home," by Campbell and Burr; "Silver Heels," by Van Eps Trio, and "Bring Back My Daddy to Me," by Henry Burr.

According to Dan J. Nolan, manager of the music department of the May Co., his firm, a department store, is doing a splendid summer business in selling Victor talking machines and records.

The Muehlhauser Brothers Piano Co. is doing a good summer business in the sale of Sonora phonographs. The firm offers machines ranging in price up to \$1,000 each.

Beuscher's music store has some very attractive window displays of Victor talking machines and records, which have come in for a considerable measure of praise. This store is one of the most artistic in Cleveland.

FORM WAR SAVINGS STAMP SOCIETY

Every Employe of New York Talking Machine Co. Enrolls—Those Who Are "Over There"

The members of the staff of the New York Talking Machine Co., Victor wholesalers, have formed a War Savings Stamp Society, and are already entitled to a 100 per cent. flag for their efforts, every employe of the company being enrolled. The society is receiving the active support of Arthur D. Geissler, president of the company, and Roy J. Keith, general manager. Miss Florence Roskam is secretary and treas-

urer of the society, and her efforts are producing splendid results.

Morris Owens, formerly a popular member of the company's traveling staff, and now in the Artillery Corps of the U. S. A., has left for France to "do his bit over there." John Connolly, who is also a member of the company's staff, left for France some time ago as one of the "Fighting Sixty-ninth," and has been in active service for many months. Kenneth Moore, a brother-in-law of Arthur D. Geissler, and a lieutenant in the Aviation Corps, left Saturday for France.

VOCALION RECORDS BY CRIMI

First Records by the Noted Tenor Advertised Last Sunday by the Aeolian Co.

The Aeolian Co., New York, featured in its advertising last Sunday a Vocalion record made by the distinguished operatic tenor, Giulio Crimi. This well-known artist has recorded several selections for the Vocalion library, including numbers from "Cavalleria Rusticana" and "Pagliacci."

Giulio Crimi has won international success as a tenor and his Vocalion records have been demonstrated the past week at Aeolian Hall, winning high praise from critics and music lovers, who believe these records will meet with a ready sale throughout the country. This famous tenor will record exclusively for the Aeolian-Vocalion record library.

The Performance



OF the *Gloria Steel Needle* both in maintenance of quality and in prompt delivery, at the uniform prices in the quantities sold, insures substantial profits.

Our *special proposition* to the trade is comprehensive. It shows how you can sell a better product to your customers at pre-war prices. And it also explains how you can make bigger profits. Write us for a copy of plan K.

Gloria Phonograph Supply Co., Inc.
200 Fifth Avenue, New York

Wm. A. Condon, *Sole Agent* for

GLORIA NEEDLES



IMPORTANT NOTICE

TO THE AMERICAN TRADE

The Sterno Manufacturing Company
19 CITY ROAD LONDON, E. C. ENGLAND

Manufacturers of the world known COMPACTOPHONE—the most complete portable gramophone extant—beg to announce the conclusion of arrangements for the EXCLUSIVE SELLING RIGHTS IN THE UNITED STATES OF THE

High Grade Motors Manufactured By **Mermod Freres** St. Croix Switzerland

WONDERFUL MECHANISM

These motors represent the acme of workmanship and quality. Each part is made to the finest gauge limits and assembled to run with the precision of a watch—silent and true. Messrs. Mermod Freres is an old established Swiss manufacturer. Back of their motors are years of hard practical experience. The experimental stage was left behind a decade or more ago. Reliability and quality is therefore assured.

DIFFERENT MODELS

Mermod Freres motors comprise several types—single and double spring worm and pinion-gear drive, the very latest and scientific method of construction.

CONSULT US

Before placing your orders elsewhere consult us as to prices and terms of trading. We are out for quick shipments and prompt delivery direct from the factory to the buyer.

SPECIAL TERMS TO JOBBERS

Within the near future it is proposed to establish
A CENTRAL DISTRIBUTING DEPOT IN NEW YORK
Meanwhile trade enquiries should be directed to

THE STERNO MANUFACTURING CO.
19 CITY ROAD LONDON, E. C. ENGLAND

Sell Foreign-language Records!

**A profitable department—small investment—quick turn-over—good service.
Write for details.**

**International Record Department
Columbia Graphophone Co.
NEW YORK**



READJUSTMENT OF PRICES AND DISCOUNTS ASKED FOR

Declared That Present Margin of Profit Is Below Pre-War Standard and Not Sufficient to Meet Increased Business and Living Costs To-day—Increased List Prices Suggested

There is apparently a well-defined movement among talking machine wholesalers and dealers throughout the country looking to a general readjustment of retail prices and discounts on both machines and records, or more particularly an upward adjustment of list prices and the fixing of discounts that will permit of a larger margin of profit for both the wholesaler and the dealer.

It is maintained that through some readjustments in the past in the matter of list prices and discounts the profits of both factors in the selling branch of the trade are smaller than they were in pre-war days, despite the fact that list prices have jumped. This in the face of the fact that, owing to stock shortage, the majority of houses are handling only 75 per cent. or 80 per cent., and in some cases even less, of the business handled in normal years, that increased taxation must be met, that salaries have been increased from 20 per cent. to 40 per cent. through necessity, and that every element entering into the business overhead has advanced.

As one prominent member of the trade put it: "Every increased expense in the business, and they are many, has had to be met out of my company's income, and at the same time both gross and net profits have been decreased despite the raising of the list prices. In the first place my volume of business has decreased over 20 per cent., due to inability to get goods. Then the profits have been subjected to another cut to meet excess profits and other taxes, and on top of this the salaries of my employes during the past two years have been increased on the average of 40 per cent. At the same time my discounts as a wholesaler are smaller than they were before the war. It is a condition that will have to be remedied, and remedied at an early date.

"The solution lies in having the manufacturers increase list prices 10 per cent. or so, and then readjust the discount so that the price the wholesaler must pay for the machine or records will approximate the sum he is called upon to pay to-day. In other words, the increase in list prices should go in toto to the wholesaler, who will in turn pass a fair proportion of it to the dealer. Under the present conditions the wholesaler has been compelled to accept a smaller profit on the capital invested, and has also been compelled to impose the same condition on the retailer. The wholesalers and retailers do not want to profiteer, but they want to make a living profit on the limited volume of business they are able to do.

"The automobile manufacturers who have had their output curtailed have met the situation by increasing list prices of their cars to a point where the profit realized on the smaller number of cars produced would, in a measure, equal profits on a normal output. By increasing the list prices and giving the increase to the whole-

saler and dealer, the talking machine manufacturer can accomplish practically the same result. The action, however, will have to come from the manufacturer. It is, of course, understood that a wholesaler or retailer can, under the present interpretation of the laws, sell machines and records at any price he sees fit, but at the same time the companies publish list prices on both machines and records, and any man with a bit of business sense knows that the list price is always the maximum price. In talking machines the public has been educated to accept it as the established price. Any change in a list price on the part of the seller is always a discount from, and not in addition to, that stated price, and, therefore, a new list price must be established before wholesalers and dealers can expect any relief.

"It has taken a good many years to build up the industry, and whether those years of effort are lost or not will depend upon the manner in which the business is conducted during the strenuous period of the war. Wholesalers and retailers must increase the salaries of their assistants to keep their trained organizations intact, for otherwise the employes are going to go into other fields where the remuneration is more generous. With their staffs practically wiped out, and with wholesalers and dealers failing to make a fair living profit under present conditions, it is only natural that employers themselves will look around to find some more remunerative field for their efforts. This will mean that selling organizations will disintegrate and that the labor of years spent in building up such organization has gone for naught. This may be overdrawn a bit, but the fact is things

cannot continue as they are. There must be found a way to give the selling interests of the trade sufficient profit to carry on.

"There may be some question about increasing list prices on machines, but it must be remembered that a machine that sold for \$200 ten years ago did not in any way come up to the instruments now being offered in the neighborhood of \$100. It is therefore seen that a \$10 or \$15 raise on a machine of this type will not in any way interfere with the volume of sales, especially as machines are scarce. In the matter of records it will be remembered that ordinary, single-faced records, ten years ago when money was not so plentiful, sold readily at \$1. Why couldn't the double-sided record of greatly improved quality bring the same price to-day, and the difference be divided between the wholesaler and retailer?

In addition to the member of the trade just quoted, other wholesalers, jobbers and dealers have voiced similar opinions, and some of them have pointed out that the increase of 25 per cent. in freight rates just adds a little more to the problem. It is very probable that some definite movement will be taken at an early date to bring about a general readjustment of the list price and discount question along the lines advocated by the sales interests. Just what form the movement will take has not been announced. From reports that have come to The World office from various sections of the country, however, it would appear that the subject is being widely discussed.

NEW ENGLAND AGENTS FOR CHENEY

The Royer Talking Machine Co., of Boston, who have been appointed New England agents for the Cheney Talking Machine Co., are developing an excellent following for this instrument down East.

Bring Those Jobs Out of Hiding

The value of your "job lots" will not be increased by keeping them on your shelves.

Bring them out into the daylight. Let us sell them for you.

We are in the market to buy for cash everything in Phonograph parts, accessories, etc.

Get in touch with us at once

THE PHONOGRAPH CLEARING HOUSE, Inc.

51 EAST 42d STREET, NEW YORK CITY

Edison Message No. 24

Encourage Community Singing

A RECENT editorial in the Musical Monitor says that one outcome of the war will be "recognition of the power of the greatest of all arts—*music*." This power will be exercised in many ways, but perhaps not more effectively than in the development of community singing.

Harmony is the soul of music. Music, especially in the form of community singing, is one of the most effective mediums for welding together the miscellaneous types that go to make up the American people, and which diversity of interest keeps more or less aloof from each other.

The Edison dealer who interests himself in community singing will help to stimulate a general interest in music which cannot fail to be of benefit to his community and of profit to himself.

A singing community is a fertile field for the Edison dealer.

THOMAS A. EDISON, Inc.
ORANGE NEW JERSEY

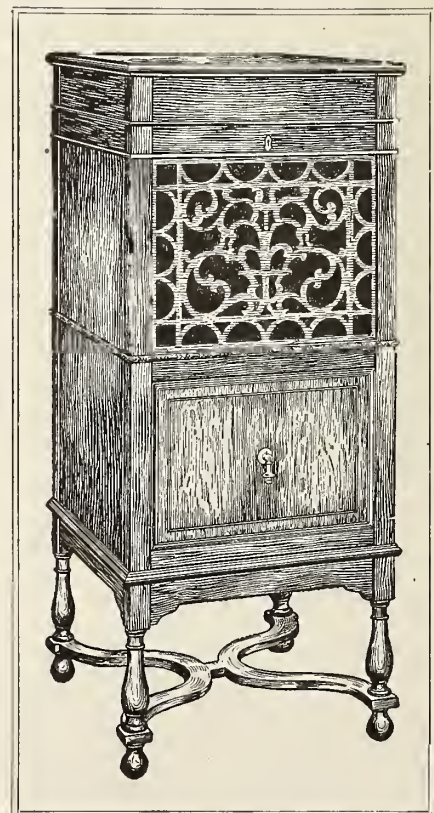

Official Laboratory Model New
Edison—William and Mary Cabinet,
executed in American Walnut.

Present Trade Situation and Its Problems Reviewed by Talking Machine Wholesalers

CONSERVATION THE WATCHWORD

By Chas. F. Bruno, C. Bruno & Son, Inc.,
New York

The watchword of the whole nation is Conservation and each day brings home to us more strongly the need for it. We are working on a wartime basis and every dealer should do likewise. This is imperative in order that the Government needs be supplied to their full measure. You all know the conditions in transportation and shortage of labor. By retrenching wherever possible and changing your methods you can eliminate much unnecessary work. Plan to help the wholesaler maintain as satisfactory service as possible during these unusual times. For instance, if it is necessary that you know what your wholesaler is shipping you, send your record order in duplicate and request him to cross off the numbers filled and mail back the copy.

In your own shop there is unlimited opportunity for Conservation. Every dealer has on his shelves records not classed with the best sellers. Make them such. Many of them are excellent records in themselves—disregarded because unknown. Study them, interest your clerks in them, get out attractive folders describing and advertising them and your supply will soon fall short of the demand. In the matter of machines, feature those you have in stock, particularly the small types. There is a market for them, but you must find it and not wait for it to find you.

Every unnecessary item of clerical labor saved for the wholesaler, every record and machine already in stock that you can sell, means that much advance toward the goal of Conservation. Conform your business to existing conditions with determination to save and serve and you will be ready to forge ahead when Liberty and Democracy have triumphed.

MUST SECURE BETTER TERMS

By John G. Corley, the Corley Co., Richmond, Va.

The music business, like other enterprises, will continue to feel the gradual curtailment due to war conditions as the Government's requirements increase for labor and raw material, which goes without saying that the music business will suffer a greater curtailment. This, however, will not be without its advantages, as the dealers will improve their terms and secure more cash business. Just as the output is decreased, terms will be increased, and we will get nearer a cash basis. These conditions, which have decreased the output, have proven a salvation to the piano business. The prices have advanced and the terms shortened. A dealer can no longer follow the old plan of selling on nothing down and anything a month, for when he goes to the manufacturer now for stock, he will be met with this question, "How do you want to pay for them?" and in many instances the manufacturer will demand cash; certainly the terms, if given, will be very short. This result has brought around desirable conditions. The piano merchant, as a general rule, is selling his goods at a uniform price. The old plan of charging Mary Smith \$50 more than Mary Jones paid is no longer in evidence, and may it please God that it will never return, but that instruments will be sold at uniform prices and on terms the dealer can pay for his stock.

Now, to the talking machine dealers. It is true that the distributors have been unable to supply sufficient stock to meet the ever-increasing demand for Victrolas and records. The trade, however, is healthy, and customers do

not make up their minds now that if they cannot get one style they will take no other, consequently this has been most helpful to the dealer, because when he does not have one style his customer will take another type.

The great shortage would not exist with the record and be so keenly felt if the sales organizations all over the country would bring to the attention of their customers the splendid numbers right in their stock. It is a little difficult to get the clerks to see this point. A customer will come in and ask for a certain number, and should it not be in stock the clerk makes no further effort to interest the customer. This must be changed to meet the general condition. Customers must be shown the stock of the dealers. The wonderful numbers in all stocks will find ready sale if they are properly shown to the customer. We very frequently hear salesmen say, "Well, we lost so many sales to-day, or this week, because we did not have them in stock." Of course, for these particular numbers the sale was lost, but the main point, as I see it, is to present and sell your customers other numbers, as this is the best way to meet the big demand for records. In other words, we must have stock conservation as well as food conservation. By carefully guarding and conserving it we help, in a way, towards winning the war.

INTERESTS OF DAY COME FIRST

By William H. Nolan, the Louis Buehn Co., Philadelphia

In these times when individual and corporate interests must be set aside for the interests of the day, the preservation of democracy and the saving of humanity, there is no time to consider personal interests at the sacrifice of the cause to which every firm and individual should be absolutely dedicated.

Nevertheless, engaged as we are in the merchandising of a product which contributes so vitally to the mental, physical and spiritual welfare of the nation, we should "carry on" our work with the realization that people, now as never before, need the inspiring, invigorating and restful influence of music.

There is no question that people are seeking places of amusement, attending concerts and lectures in greater numbers than ever before, showing clearly the need for diversion, relaxation and stimulation. This is recognized in England and the Government is calling back entertainers and musicians from the front, so that the people who must work with power and inspiration will not be denied that which contributes most to creative life.

Our own Government has realized this fact, and even though various conditions have materially lessened the production of our own product—Victrolas and Victor records—they have not by any means been classified as non-essential.

Salesmanship of the highest order, aggressiveness in the finest degree should be the rule of every person engaged in the Victor industry, selling that which we have or can get rather than bemoaning the fact that there is some merchandise we are unable to procure.

Take not only an inventory of your stock but an inventory of your present equipment and selling methods. Realize that to profit now and to insure your profits in the future you must dig deeper than ever before into the stock of the hundreds of records you are carrying on your shelves and into your community for sales opportunities.

Do not make the mistake that has been made in the past by many dealers of accepting poor instalment business; for now is the time to

realize on the good cash business which is available through wage earners making the biggest salaries they have ever enjoyed.

You will attract and get these cash sales and the steady stream of cash record trade, not by the old appeal or by pre-war methods, but by connecting up the need of the product which you are selling with the actual need of the people for it. In this way you will be doing your part and make the people realize that music is an essential and not a luxury.

The achievements of the past, the present supremacy and superiority of the Victor line, the ever forging ahead policy, cause one to trust and believe to the point of absolute loyalty in the power of the Victor Co. to weather the present conditions, coming through supreme as before in all things—perfection of product, bigness of vision, power of production and fairness in their business dealings.

CONDITIONS IN MIDDLE WEST

By Arthur A. Trostler, Schmelzer Arms Co.,
Kansas City, Mo.

I am going to dwell on "Conditions in the Middle West." Never have I seen such crops as we are having in this part of the country. I remember a few years ago when we had a bumper wheat crop of about ninety million bushels, which sold at a price of about 65 cents, when to-day we have one hundred million bushels, selling for over \$2 a bushel. Can you conceive such a condition? This is only one item. You take the corn, alfalfa, oats and other items, the prices they receive to-day and what it means for the merchants.

Victrolas are not being sold, they are simply being bought by the farmers and the people in the cities. We have been unable to build up a stock of any type of Victrola. As fast as they arrive, just so fast they are shipped to our dealers. Conditions in this territory are such as we have never experienced before. We have dealers coming in to see us every day and they say, "Ship me anything with a Victor trademark," because it can be sold.

We are enjoying a very healthy business, and if we could just get the goods, there is no telling of the volume we would be able to do. The dealers throughout this territory are optimistic. We had a great many of them in last week during the Rotary convention, and they have a different line of talk than they have had heretofore.

In conclusion, allow me to say our dealers are not in a position to build up any stock, therefore, we fear that the market on Victor goods will be very low this fall.

JOBBERS WORK TO HELP WIN WAR

By George E. Mickel, Mickel Bros. Co.,
Omaha, Neb.

This year, as never before in our nation's history on Independence Day, we do not proclaim our patriotism by fireworks and pyrotechnical display, but by going about the nation's business, and that is—to help win the war. We must each one of us get the conception that there is but ONE big business in this country, it matters not whether we are running a talking machine factory, a bank, or plowing corn, these are all subsidiary to the one main object—winning the war.

I believe that our association acted wisely when it decided not to hold the national convention this year. This requires that each executive officer make greater exertion for the good of the organization. The times require

(Continued on page 85)

Today and the Future

OWADAYS I do but little traveling and little soliciting. I make but few calls. Nowadays business problems are complex the problems of labor and of raw materials.

And it is the policy of Stephenson, Inc., to care for, to protect, their present day customers rather than to solicit new business.

But I look forward to the future with faith and confidence. I look forward to the day when, with still greater manufacturing facilities and unlimited sources of raw material supply, I can serve a greater number of manufacturers with the Stephenson Precision Made Motor.

Cordially yours,

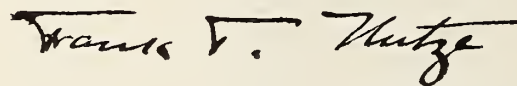

Vice-President

STEPHENSON, INC., One West 34th Street, New York

PRESENT TRADE SITUATION AND ITS PROBLEMS REVIEWED

(Continued from page 83)

that each man in his line of business must spend more thought on ways and means than ever before.

We must put on a "Tom Sawyer" front, some whitewash, with a sunny smile and a cheery word.

The Victor Talking Machine Jobbers' position is no different than that of many other lines. The tearing of hair because of shipments that are not large enough and after they HAVE been shipped do not arrive, gets us nothing. We want to continually keep in mind that we are marketing the biggest and most popular line of talking machines in the world. Futile individual efforts will accomplish but little, but abiding by and following well-defined principles will bring us ultimate success.

We can do our bit by exercising a spirit of cheerful co-operation. We grow by continually altering our views. The last word is never said, and, as conditions change, our opinions must be adjusted.

The meeting of the bigger men in our line has always inspired us with stronger purpose, higher ideals and greater enthusiasm, and we all anticipate that some time in the near future we will have the privilege of renewing these acquaintances.

MEETING WAR CONDITIONS

By J. Newcomb Blackman, President Blackman Talking Machine Co., and National Association of Talking Machine Jobbers

Those industries which are doing everything possible to voluntarily and efficiently meet the present war conditions, having always in mind the great reconstruction period which is sure to follow the war, are not only safeguarding the solid foundation on which their business has been built, but are insuring it for the future. In recommending to its membership the cancellation this year of its usual annual convention, the executive committee of the National Association of Talking Machine Jobbers did so in the spirit of meeting patriotically war conditions. Our conventions have always involved considerable expenditure of time and money, by reason of distance traveled and the usual entertainment features. Had the convention been held as ordinarily, the festivities would have been largely curtailed or eliminated.

Then, again, aside from the advantages of patriotic co-operation in the war program, there is at present little opportunity to shape constructive policies. This, of course, is owing to the fact that, starting with the factories, trade is curtailed and regulated in a manner best suited to give first consideration to war needs. The factories are not in a position to explain their relations with the Government, and such restrictions as may be necessary in carrying out their obligations for the manufacture of war munitions or general conservation of material and labor. In view of this, it seems best that any matters considered of sufficient importance to be taken up with the factory for the selling side of the business can best be presented through the executive committee, or even a special committee; and this plan has been followed, and probably will be found the wisest one for the future.

The war has been, and we hope will prove, a constructive pruning knife for all industries. In the talking machine business the pruning has taken the form of curtailed product, and enforced restrictions, which will bring about needed economies. On the other hand, the great need of labor and corresponding high prices of wages introduces a serious problem for the distributors and dealers who are not engaged in war work. The factories, no doubt, will maintain full activities, although a large percentage of production may necessarily be Government work. The present standard of excellence represented in the product and selling personnel of our industry has been brought

about by the cumulative effort of about twenty years. Patriotic merchants are willing to make any necessary temporary sacrifice through curtailed product and reduced sales as well as profits, but it is to be hoped that this process will be one of a pruning nature, which will not cut so deep as to seriously injure or kill the industrial plant. In other words, distributors and dealers have the same constantly rising costs of doing business. This, of course, means that their overhead has steadily increased. The factories have met like conditions by raising their prices, and so far such raises have been very small compared with similar merchandise; in fact, records and machines to-day, with even considerable further advance, would represent value much greater than was given only a few years back. It is customary in all lines of business to have a retail selling list price, and this has always been regarded by the buyer as the maximum price. This custom has been so uniform that it is quite impossible for a dealer to charge more than the list price without holding himself easily subject to severe criticism as exacting an unfair profit from customers.

In order that the trade can continue the efficient representation which the factories must have if we are not to deteriorate as an industry after the war, the margin of profit must be maintained. This is especially so when everything points to continued curtailment of product, which will bring about a corresponding reduction in sales—otherwise talking machines will quickly go back into the bicycle shop and among the kitchen utensils. The talking machine shop should have a special organization, trained to intelligently serve the public—therefore, cannot safely be reduced or lowered to the plane of the variety store. Future increased prices, owing to additional taxes and other war expenses, will probably be necessary. The factories will do well, in my opinion, to leave sufficient margin between the distributor's cost and the list price, to enable the distributor to sell the dealer at a price which will give him a good margin of profit when selling at list prices.

To keep the home fires burning in the talking machine business we must keep the business running. The pruning process will eliminate the drones and parasites, but when our employes, now in the service, return as "Victorious Heroes," I know of no better way to insure a welcome than to say that we are able to offer them an opportunity to resume the activity of their brains and training where they will produce the best results.

Concluding, may I say that if we can all curtail, sacrifice and adjust all business and social life during the war, spreading out the burden as thin as possible, the trying period of reorganization will not be the great problem that many fear. Labor will not have been so shifted and business so upset or ruined that resumption would be impossible for a long period of time. Our Government officials are realizing the importance of doing this, as indicated by the recent establishment of a War Labor Bureau, which will have in mind conserving labor in each locality, and avoiding the costly disorganizing effect of industries constantly bidding against each other for labor. War activities, it seems, will now be spread more evenly throughout the country, thus making the labor problem an easier one, to say nothing of that of housing labor.

The talking machine industry has made great strides to eliminate the first hasty reference to it as among the so-called "non-essentials," but there is much more that should and can be done. A large part of the money spent in advertising should be used in furthering the sale of Liberty Bonds, War Savings Stamps, and in aiding the Y. M. C. A., Red Cross and other patriotic drives for funds. Machines and records should be used to the utmost to inspire those at the front and at home. The power of

music has been felt and aided victory in the past, and with the help of the entire trade another year will show much greater strides in that direction.

DISCUSSING NEW WAR REVENUE BILL

Treasury Department Suggests 20 Per Cent. Tax on Musical Instruments—Matter Now Under Consideration by Ways and Means Committee

As The World goes to press the new War Revenue bill is still the subject of the hour before the Ways and Means Committee in the House of Representatives at Washington. The Treasury Department has made a number of suggestions in the matter of taxes to be levied on the various lines of industries, the department's figures being based, it is said, upon returns under the present law. The trade will be interested to know that the Treasury Department suggests a 20 per cent. tax on all musical instruments which, it is understood, will include talking machines and records. It is not likely, however, that any such drastic tax will be levied against this industry when the matter is finally threshed out.

At the hearings held before the Ways and Means Committee some time ago preparatory to the drafting of the new law at which representatives of various industries appeared, the talking machine trade was ably represented by Marion Dorian, of the Columbia Graphophone Co., New York. Mr. Dorian pleaded strongly for a repeal of the present tax, which he declared had had a serious effect on the industry and emphasized as a reason for leniency the part that the talking machine is playing in supplying music and entertainment for the fighting men in the army and navy, as well as maintaining the courage and patriotism of the people at home. He declared that no other musical instrument was used so extensively as the talking machine in military life.

TALKING MACHINE MEN, INC., MEET

Next Session Scheduled for July 17—Philadelphia Association Officials Invited to Be Present at the Meeting in Woolworth Building

E. G. Brown, secretary of the Talking Machine Men, Inc., is doing some excellent work in the interests of that organization, this work including the presentation of a report of what occurs at the various meetings. Mr. Brown put the report of the last meeting in rather original form by arranging it so that the first letter of each line appeared in red, and when read in sequence spelled "Talking Machine Men, Inc."

The next meeting of the organization will be held in the assembly room of the Merchants' Association in the Woolworth Building on next Wednesday afternoon, July 17, at 2.30 o'clock. An invitation has been extended to the executive committee of the Philadelphia Association to attend the meeting, and it is hoped that a delegation from the City of Brotherly Love will be present.

L. C. McCHESNEY TAKES A REST

It took the orders of a physician to make L. C. McChesney, director of advertising of Thomas A. Edison, Inc., leave his desk for a temporary rest. Mr. McChesney, therefore, has been enjoying, or rather enduring, a brief respite from business cares at his home in Orange, leaving Arthur J. Palmer at the helm during his absence.

The Yahr & Lange Drug Co., of Milwaukee, distributor of the Sonora phonograph and records in Wisconsin and Upper Michigan, has announced the appointment of Julius Koepke, Whitewater, Wis., as a new retail dealer in Walworth County. The representation in Milwaukee County is confined to eight retailers of the Sonora, six of whom are located within the city of Milwaukee.

PITTSBURGH TRADE ENGAGED IN MANY ACTIVITIES

Accomplishing Results in Featuring Standard and Foreign Records—Association Doing Good Work
—Victrola Before Educators' Association—Changes in the Various Sales Staffs

PITTSBURGH, PA., July 6.—Despite the depletion of sales organizations, due to voluntary enlistments in the military service of the country, and likewise the operation of the draft, coupled with the continued stock shortage, talking machine wholesalers and dealers in this city are doing exceedingly well, considering conditions. The main effort, of course, is concentrated in the selling of standard records and particularly of foreign records, for Pittsburgh has a foreign population that makes the handling of the latter records well worth while. Incidentally, the members of this foreign population are making plenty of money and are willing to spend it for both machines and records.

The interesting news of the month revolves around the activities of the Talking Machine Dealers' Association of Pittsburgh, which followed up its action in advising the internment of all records of German flavor for the period of the war by resolving to withdraw all advertising support from the newspapers printed in the languages of nations at war with the United States. The full text of the resolution appears in a special story in another section of *The World* this month.

Inasmuch as a number of talking machine men are already in service, or are planning to go into service, a movement is on foot to have the association keep in touch with these men, whether in this country or in France, and keep them advised regarding the happenings in the local trade, and thereby keep their interests in the industry alive.

Those attending the convention of the National Educators' Association held in this city last week had strongly impressed upon them the educational value of the Victrola and Victor records through the efforts of Miss Lillian A. Wood, who is in charge of the Victor educational department of the C. C. Mellor Co. Dur-

ing the week Miss Wood arranged a special series of folk dances by local school children to the music of the Victrola and also demonstrated the use of the talking machine in training in penmanship, history, geography, general music study and in other ways. Refreshments were served to those who attended.

The Starr Phonograph Co., of Pennsylvania, who act as distributors for Starr phonographs and Gennett records, report notable progress for those lines in the Pittsburgh district, the company securing very good supplies of both machines and records, due largely to the efforts of H. G. Niles, secretary-treasurer of the company, who keeps in close touch with the Starr factory in Richmond, Ind. A number of prominent dealers have been added to the company's list, among them being the J. M. Hoffman Co., the prominent piano house, and also the Dawson Bros. Piano Co.

The latest machine, designed particularly for the use of fighting men, which has come to the attention of the Pittsburgh trade is the army and navy style Pathéphone. This machine is built with a special view to hard service, and has made a distinct impression, and it was not long before several had been sold to military organizations, as well as to civilians who desired something of the sort for use on camping trips.

Aeolian-Vocalion records which were introduced here some time ago through the medium of the talking machine department of Kaufmann & Baer Co., of which H. C. Hornberger is manager, have met with great success. The Vocalion phonographs are already well known here, and associated with that machine and backed by the Aeolian Co.'s reputation, the new records were accorded a hearty reception. Sales of Vocalion records are on the upward trend.

P. W. Kline, manager of the talking machine department of the Rosenbaum Co., has entered

the military service, and has been succeeded by F. G. Passoth, who has long been connected with various houses in the local trade. Another member of the local trade who has entered the service of his country is W. R. Roberts, formerly connected with the wholesale talking machine department of the C. C. Mellor Co. He is now in the navy.

A unique feature recently introduced by the Columbia Music Co., under Manager John Henk, is a service department where all makes of machines may be adjusted or repaired, and where owners may procure first-hand information regarding the care and operation of their instruments.

KIMBERLEY CO. OPEN IN NEW YORK

Manufacture the Kimberley Phonographs—Act as Jobbers for Thomas Motors

The Kimberley Phonograph Supply Co. has just opened offices at 206 Broadway, New York, and, in addition to manufacturing a complete line of "Kimberley" phonographs, will also act as Eastern jobbers for the Thomas Dayton motors, tone arms and sound boxes. The company has advised the trade that it is ready to supply the dealers with a line of machines retailing from \$40 to \$200, and arrangements have been completed whereby the company will manufacture its own cabinets in a well-equipped factory up State.

W. Brand, formerly associated with the Otto Heineman Phonograph Supply Co., is general manager of the Kimberley Phonograph Supply Co. He recently visited the trade in the East, and made several deals whereby the "Kimberley" phonograph will be represented by retailers in important trade centers.

Harry Stadlmair, son of Henry Stadlmair, vice-president and general manager of C. Bruno & Son, Inc., has joined the U. S. Aeronautical Corps, which specializes in the cutting of spruce timber for aeroplane construction.

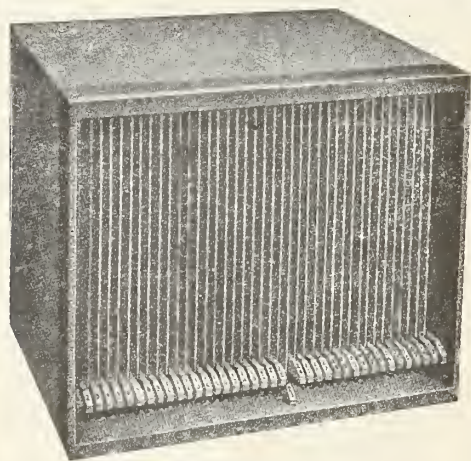

Style 70—Retail \$10.00

7 IN 1

Seven strong points in our feature is a powerful selling argument.

1. Controlled entirely by gravity. Will not get out of order.
2. Non-abrasive individual record compartments.
3. Records cannot warp, scratch or mar and are kept clean.
4. 10" and 12" records can be filed in any compartment indiscriminately.
5. In beautiful oak and mahogany finish. Polished, waxed and dull finish.
6. Automatic out signal shows "when and where" a record is missing.
7. Filing and finding a pleasure. Get the desired record when it is desired.

COLUMBIA DEALERS: Eject-o-files are built to fit the style 75 and others. Slip them in as they are wanted. Why carry that big stock of 85's, etc., when the Eject-o-file does the trick? "The Eject-o-file is Efficient" and you are in business for dollars and cents.

VOCALION DEALERS: A receptacle for records that can be slipped into your style F.-G.-H.-J.-&-K. They are "built to fit." Wonderful convenience and a powerful selling argument. Ask the Salesman.

EDISON DEALERS: Eject-o-files are built to fit the style C-150 and 100. Many dealers are reaping the benefits. Why not you?

"BUILT TO FIT" any machine and a powerful asset for any dealer. Why offer Albums, Envelopes and other antiquated methods of filing to your customer? Eject-o-files are modern and efficient. Prices are phenomenally low.

The "sectional Eject-o-file," an auxiliary cabinet, compact, large capacity. Can be conveniently placed on table, stand, etc., or stands especially adaptable can be had. Beautiful and artistic, mahogany and oak finish, polished, waxed or dull. Each section a complete unit, can be added to, one upon the other, you know, sectional bookcase idea.

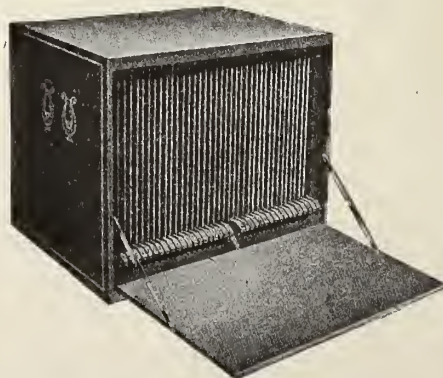

Style 60—Retail \$15.00

EJECT-O-FILE SALES CO.

216 W. Saratoga Street

Baltimore, Md.

PERSHING RECORD NOW READY

Dealers Can Now Get the Famous Message of the American Commander From the Columbia Graphophone Co.—The Nation's Forum Idea and What It Means in Developing Patriotism

Deep down in the hold of an unnamed ship that navigated the death-infested waters of the submarine zone there has come to America a document that is destined to live as long as civilization itself; a message sure to take rank as one of the conspicuous milestones in the slow and tortuous march of human liberty through the ages from the very dawn of history.

It is the clarion call of the foremost warrior of the greatest nation under the heavens—an appeal spoken amid the storm and stress and frightful carnage of Armageddon, which, through the marvels of modern science, shall echo to countless generations unborn.

This priceless object is the matrix of a phonograph record on which General Pershing registered in his own voice an appeal for unflinching support of the army, which will be thundered forth from phonographs in patriotic meetings, rallies, school, club and social gatherings, and in homes throughout the length and breadth of the land. The massive copper master record from which the thousands of phonograph discs are now being struck off by the Columbia Graphophone Co. in its Bridgeport factory will find its resting place in the national archives, where the historic documents of the country are treasured.

These records are now on sale. They are being distributed through the dealers of the Columbia Graphophone Co., every one of whom is expected to co-operate heartily in the sale of an article which every patriotic American citizen will want in his home.

To secure the Pershing message recorders were sent to France by the Nation's Forum, armed with letters from Washington and equipped with the most efficient type of voice registering apparatus. The serial battle of Picardy and Flanders was at its height when they reached American field headquarters, yet no time was lost in setting up their plant and getting to work. It is easy to imagine the difficulties encountered in recording Pershing's words with the thunder of guns wafted from the distant fighting line and the roar and clatter of military activity at hand.

When an acceptable record finally was secured the wax impress was rushed to London and given its copper shell which forms the master matrix. This was done to avoid the possibility that atmospheric conditions aboard ship might destroy the delicate wax had the latter been forwarded. As already explained, several shells were made and carefully concealed at distant European points as a further protection, and the original copper matrix was started on its perilous voyage to America.

The Columbia Graphophone Co., because of the vast patriotic value of this record, is making the duplicate records without profit, in order to assist in getting them into every home in the country.

The broadcast distribution of this Pershing record will mark the initiation of a plan long under preparation to employ the phonograph for patriotic propaganda and which has taken form in the organization of the Nation's Forum, with headquarters in Aeolian Hall, New York.

The germ of the idea out of which this movement grew had its inception in the brain of Guy Golterman, a prominent attorney of St. Louis. The value that Mr. Golterman emphasizes in preservation of these wartime addresses for posterity has the attention of the Government, and of noted educators. Immediate benefits will be derived through a nation-wide school of patriotism.

Wm. S. Parks, manager of the Columbia branch at Baltimore, was a visitor to New York recently, bringing with him optimistic reports of the business situation in his territory.

EXECUTIVE COMMITTEE TO MEET

Arrangements are now being made for a meeting of the executive committee of the National Association of Talking Machine Jobbers, with the place and date still unsettled. President J. N. Blackman of the organization has been in communication with the various members of the committee, and some important matters will be taken up and discussed at the session.

CHEERY REPORT ABOUT BUSINESS

LOUISVILLE, KY., July 10.—H. B. Boswell, manager of the talking machine department of the Kaufman-Straus Co., Inc., this city, has just returned from a trip to the South and reports a greatly increased business with the Southern Edison and Columbia dealers, who view the outlook most optimistically. Mr. Boswell states that his department has the best business in its history, for instance, the month of June showing an increase of 200 per cent. over the same month of last year. The talking machine department of the Kaufman-Straus Co. is moving into its new and larger quarters, which will undoubtedly add to the development of this business.

The Pathé line of phonographs and records is being splendidly advertised in Denver, Colo., by the Daniels & Fisher Stores Co. Albert Doan, manager of the department, recently issued some very attractive leaflets.

REPORTS BIG DEMAND FOR RECORDS

J. M. Kohner, Sales Manager of Lyraphone Co., Has Excellent Western Trip—Inaugurate New Methods of Dealer Co-operation

J. M. Kohner, sales manager of the Lyraphone Co. of America, manufacturers of the Lyric records, returned early last week after an eight weeks' trip visiting the trade in the South and Middle West. Mr. Kohner is well pleased with the results and states he found the demand for records very heavy and the prospects for both summer and early fall business to be very healthy. The distributors, he said, are making heavy shipments to the trade in their localities in both the popular records and the standard catalog.

Several new methods of co-operating with the trade and in giving their records additional publicity have been arranged for by the company. Among these is a new attractive display card with an easel back in which the monthly record releases can be inserted. This always brings the card up to date and the company feels at the same time it is more attractive than the hangers they formerly used. The monthly catalog has been entirely rearranged in style and these are sent out with the imprint of the jobber or the dealer on them when the same is arranged for.

W. C. Volk is now manager of the Edison Shop of A. F. Odell, Quincy, Ill.

**COLUMBIA DEALERS
HERE'S A MONEY MAKER**



NICKEL PLATED
25 CENTS

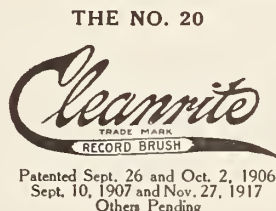

GOLD PLATED
50 CENTS

Gives
A CLEAN SWEEP

And
Leaves
A Clean
Track

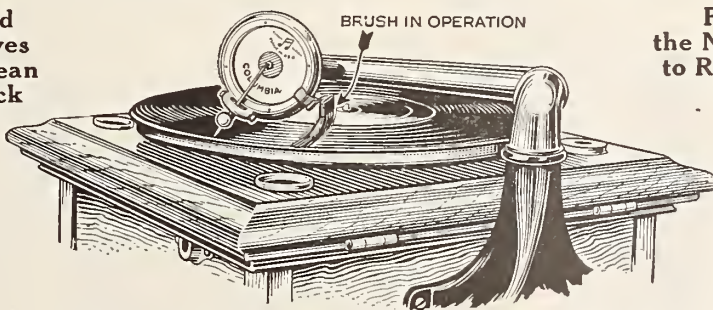

For
the Needle
to Run in

Sample Brush and price list mailed **FREE**
to authorized Columbia Dealers

Advertising matter supplied with orders

Manufactured by

Blackman
TALKING MACHINE Co.

97 CHAMBERS ST. NEAR CHURCH ST. NEW YORK

TALKING MACHINE MEN'S MEETING

Many Subjects of General Importance Discussed and Acted Upon at Recent Gathering

An interesting, and at times exciting, meeting of the Talking Machine Men, Inc., was that held in the rooms of the Merchants' Association on Wednesday, June 19, in the course of which a long pending question whether the talking machine jobbers should enjoy active or associate membership was finally settled by voting that the by-laws be amended to admit jobbers and wholesalers only as associate members. This was done, although the constitutionality of the action was strongly questioned by some.

Another event of interest at the meeting was the presentation of the resignation of Landay Bros., Inc., the Victor wholesalers, which was offered in a lengthy letter from Max Landay, president of the company, in which he condemned the resolution passed by the executive committee of the Talking Machine Men, Inc., recently endorsing the action of the New York Tribune in the criticism by that paper of Landay Bros. advertising. Mr. Landay in his letter termed the action of the executive committee a "star chamber proceeding." In the course of the meeting I. Kurtz inquired of the president why he and Max Landay, as members of the executive committee, were not notified of the meeting at which the resolution in question was adopted. The resignation of Landay Bros. was accepted, after a vote of thanks had been given to Mr. Landay for his work in behalf of the organization, and particularly in building up its membership.

The question of wholesalers operating retail stores, thereby, as it was termed, competing with the dealers while enjoying a wider margin of profit, was again brought up at the meeting, and resulted in a heated discussion, some dealers urging that orders be placed only with such wholesalers as did not sell at retail themselves. One prominent wholesaler took occasion to defend his operation of retail stores,

claiming that his retail interests had been in a large measure "wished on him" and had taken them up only to protect his own business.

In the course of the meeting a telegram from Wm. H. Richardson, of the Talking Machine Dealers' Association of Los Angeles, Cal., was read in which he made inquiries regarding wholesale discounts now in effect in the East. It was found that there was a difference in discounts in the Eastern and Western sections of the country, but it was learned that Los Angeles dealers had managed to have the matter adjusted to their satisfaction.

The communication from the Talking Machine Dealers' Association of Los Angeles brought up again the question of the organization of a national body, many members believing that the formation of a national organization was quite feasible at the present time, owing to the existence of a number of local associations which might possibly merge into one.

One of the interesting subjects of discussion were the plans for the annual outing of the organization which will be held on August 10 at

COLUMBIA RECORD INDEX ISSUED

Practical Booklet of Value to Record Owners Just Off the Press—Attractive Vacation Folder

The Columbia Graphophone Co. has just issued an attractive booklet that has considerable practical value entitled "An Index for Columbia Records and Musical Menus." In this booklet there is listed a comprehensive repertoire of Columbia records; ten records from each of the major classes of music being listed under their respective headings. The selections included are representative of everything that is worth while in music and entertainment, and were selected from the general Columbia catalog.

Following the list of each set of ten suggested records are blank spaces which can be utilized to fill in data regarding records of individual choosing. There is a right hand margin on each page for index information. In the fore-



Read the Trade Mark carefully, hear the machine, and you'll agree that it is truly

The World's Musical Instrument
Improves All Records
Send for our Special Proposition

HOFFAY TALKING MACHINE CO., Inc.
3 West 29th Street New York City

Bear Mountain. Excursionists will leave the foot of West Forty-second street on the Albany Day Line Boat at 9 a. m. A dinner will be served at the Bear Mountain Inn, and there will be games of all sorts and other entertainments.

The Jersey Talking Machine Co. was elected to membership in the organization and several applications were received.

A grievance committee, consisting of Theodore Arison, E. H. Smith and J. Schick, was appointed to take up various matters of importance not handled at the regular meeting of the association.

The secretary's salary was increased from \$150 to \$200 per year.

word of this interesting booklet there are presented several excellent suggestions regarding the filing and indexing of records, whereby the owner of a Grafonola can secure maximum efficiency in the arrangement of a record library.

A timely four-page folder has just been issued by the advertising department of the Columbia Co. featuring Columbia Grafonolas suitable for vacation use. This folder is attractively designed, and in addition to presenting illustrations of two table Grafonolas, contains a selected list of records that cannot fail to give enjoyment to music-lovers. The front cover of the folder is appropriate for vacation time, showing thumbnail illustrations in colors carrying out the idea of a Grafonola for the mountains, for the seashore and for the dance. On the last page of the folder is reproduced one of the larger models of Grafonolas, and there is sufficient room on this page for an imprint of the dealer's name and address.

Introducing The PARR CENTRAL-UNIVERSAL TONE-ARM

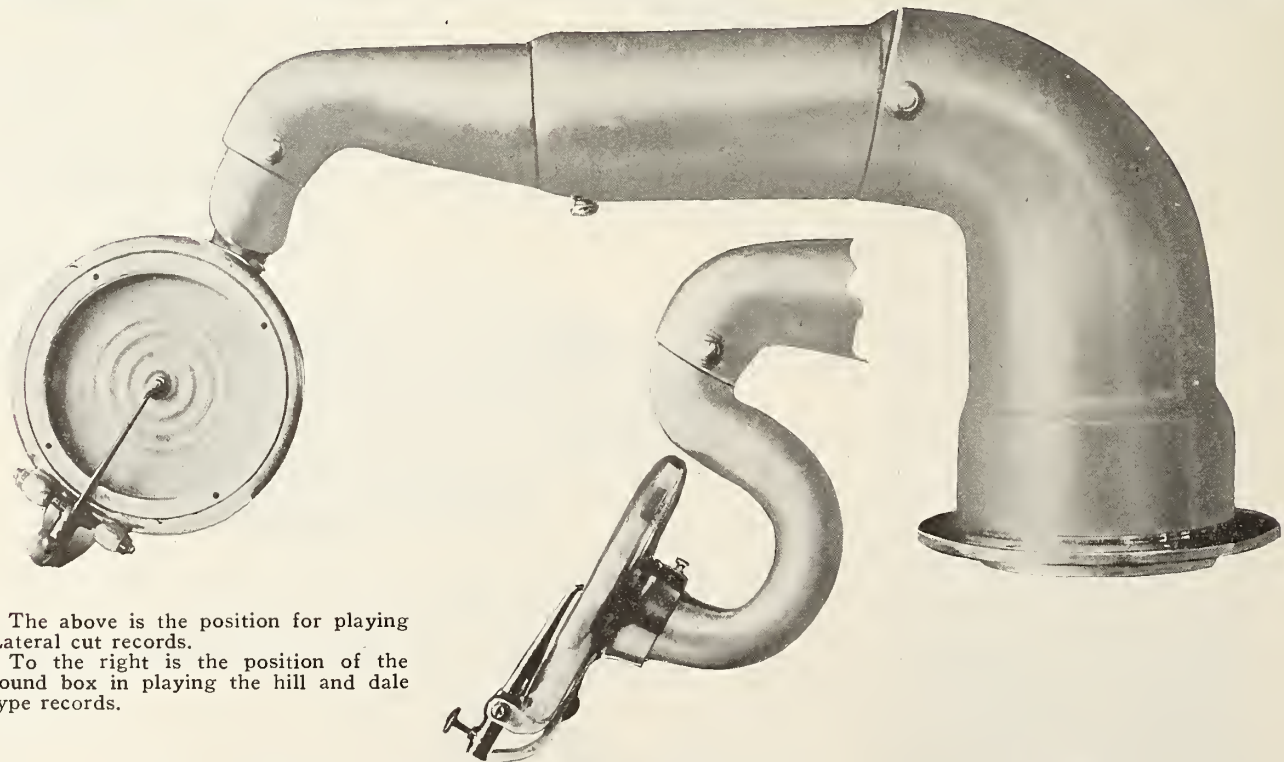

The above is the position for playing Lateral cut records.

To the right is the position of the sound box in playing the hill and dale type records.

The Parr Central-Universal Tone-Arm is offered to the manufacturers who desire a tone-arm, playing all types of records, giving perfect reproduction, and is so simple in arrangement as to be fool-proof. The Parr Central-Universal Tone-Arm, together with the Parr Magnetic Reproducer, embodies all the known principles of sound reproduction, and has in addition Parr patents to facilitate their use.

The Parr Tone-Arm is adjustable to any length required. The needle always rests at the same point, setting in the direct center

in playing either position. This has been the objective of all past tone-arm productions. Means are incorporated for taking up the wear, thereby overcoming any tendency for loose joints, which is the chief cause of "chattering."

The design of the tone-arm permits perfect playing of either type of record without additional attachments. The sound-box can be turned, allowing the needle to be changed with ease, and by a reverse movement the box returns to its normal playing position.

PARR MANUFACTURING CO. (Manufacturers of the Parr Magnetic Reproducer) **One Union Square, New York City**

SOUTHERN CALIFORNIA TRADE BUSY

**Enormous Demand for Machines and Records
Difficult to Fill—Many Changes in Sales
Force, Owing to Men Going to Front**

LOS ANGELES, CAL., July 4.—It really was astonishing how business increased during the month of June over the preceding months. The demand for both machines and records was steady during the whole month, and a great many of the larger models in all makes were sold. Of course, the local dealer is up against the same old proposition as of old, his inability to get the goods and this is certainly a great handicap. It is very discouraging to have good prospects lined up for machines and then not be able to supply them when they are ready. However, this does not seem to be merely local, but all over the country, as some of the houses have found out when trying to get goods from the Eastern jobbers, for they seem to be in as bad a condition as the ones on the Coast. There has been some talk of the dealers comparing stocks, especially records, and then trading the ones that they are long on among themselves. This has been tried out in the East and has been very successful.

A great many changes have taken place during the last six months in the sales forces of the different dealers. A great many have been called to the army or navy and still others have taken up some other branch of work.

All of the Los Angeles music houses are proud of their records during the various "drives" this year, and all without exception have gone "over the top" every time.

W. S. Gray, 530 Chronicle Building, San Francisco, has been in Los Angeles the last ten days. Mr. Gray, who for years was Coast manager for the Columbia Co., with headquarters in San Francisco, is now handling talking machine trade accessories and he reports business good in the large territory which he covers.

C. S. Ruggles, of Sherman, Clay & Co., local Victor jobbers, says that he cannot get enough goods. Both machine and record shipments seem to be moving very slowly, and he never knows when a car starts from Camden, N. J., just when it will arrive in Los Angeles. Mr. Ruggles has been remodeling his showrooms.

William Hobbs Richardson, manager of the talking machine department of the Southern California Music Co., has just returned from Camp Lewis, Wash., where he went to bid his brother, who is going to France, goodbye.

Harold Jackson, manager of the talking machine department for the Wiley B. Allen Co., has lost all of his boys, and now has to depend entirely on girls for salespeople. Mr. Jackson made several large sales during June, among them being an electric Victrola XVII and a Louis XV, Edison model 375.

Raymond G. Smith, better known to the trade as "Cy" Smith, and for many years connected with the sales force at the Southern California Music Co., has gone to join our fighting force and is now enrolled on the honor list of the United States. Mr. Smith will take a two months' course, under Government instructors, at the Normal School in this city. This class, about 650 in number, will specialize in mechanics.

O. A. Lovejoy, manager for the Edison Phonograph, Ltd., wholesale, is very well satisfied with business in general and says that the outlook

You Need This Record System

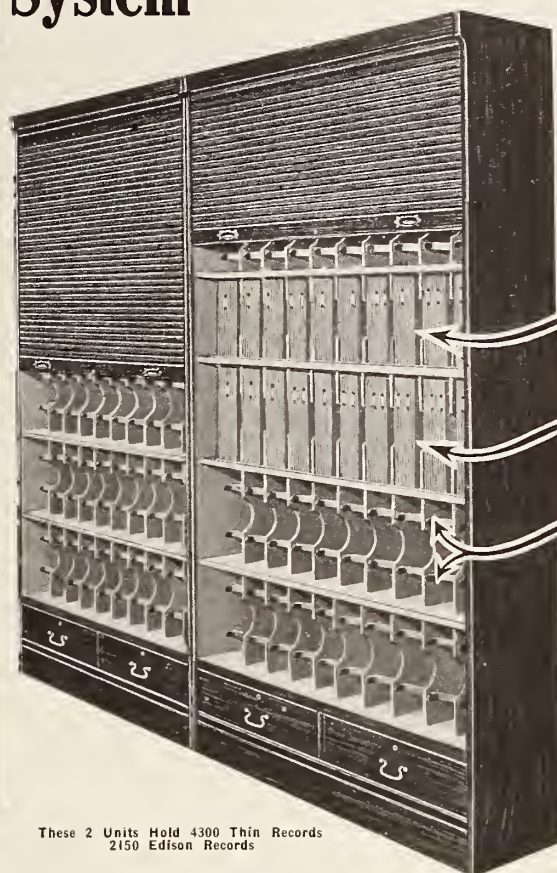

1 Clerk does the work of 2. Every Record at your finger tips. Code Signals Sell the Records you have, similar to those called for—which are out of stock. (Very important under present conditions.)

A simple Automatic Re-Order System shows what you need. The Sales Record indicates profitable sellers.

350 10" Records in Each Section.

Adjustable for 10" and 12" Records

Soft Flat Springs Hold Records Straight Up and Prevent Warping

A Locking Roll Top Prevents Dust and Theft

These 2 Units Hold 4300 Thin Records
2150 Edison Records

If it doesn't increase your sales and save you time, it is returnable for full credit.

Write for our Catalogue and list of distributors.

Regular Models for all size Records.

Immediate Shipment from stock.

OGDEN SECTIONAL CABINET CO., Inc. LYNCHBURG VA.

is fine. They have received several large shipments lately, which puts their stock in very fair condition. This company has moved from the second to the ground floor, and now have one of the best equipped jobbing houses on the Coast.

Lyon-McKinney & Smith are doing a nice business in the Brunswick line, and have lately received a shipment of new machines—among them some of the art models.

PRICE CUTTING BEING CONDEMNED

By Federal Trade Commission as Unfair Trade Practice—Comments by N. Y. Times

The question of price cutting versus price stability in the trade field was the basis for a very pertinent and timely editorial in the New York Times of Monday, July 8, which we feel sure will be read with interest by talking machine men. It read:

"The public is so in love with price cutting that the Federal Trade Commission is bold in condemnation of it as an 'unfair' trade practice. Last week the commission dismissed the complaint against a tobacco company as 'unfair' because it refused to sell to a firm which refused to maintain prices. The commission also ordered a leading mail order house to desist from advertising cut prices on the ground that the size of its business enabled it to do so. The fact was that the company sold \$780,000 of sugar at a loss of \$196,000, and looked for its profit in the degree to which the 'bait' was taken by bargain hunters. If advertisements of that sort are taboo, and if a reputation as a price cutter is enough to bar him from rank with other buyers, long steps have been taken toward the establishment of prices on a national basis.

"The action of the commission is surprising, for it has been looked to for popular action. It thus takes issue with many decision of the courts sustaining price cutting as a legitimate device to attract trade. The conflict between

the commission and the courts is no more marked than that within trade circles, there being strong factions in support both of price cutting and price maintenance. If price maintenance is stopped by local price cutting, there will be a loss of goods which will not be produced for local markets, and which cannot be produced for national markets at local cut prices. Millions are spent in establishing national markets for trade-marked goods which it would be a loss to the public to be deprived of. On the other hand, other millions are spent in attracting buyers by more or less delusive but undeniably attractive cut prices. The profits, of course, are made on other goods, and the local sellers are indifferent to the loss and embarrassment of nationalized products.

"It is a pretty quarrel, and might as well be settled by the common sense of the bargain hunters as by the action of courts and commissions. The necessity of such action suggests that bargain hunters have been deficient in price judgment, and that they have needed governmental guardianship of their interests against those who would profit by their fondness for being humbugged."

PISCATORIALLY INCLINED

W. G. Pilgrim, assistant general manager of the Otto Heineman Phonograph Supply Co., and A. S. Ribolla, manager of the Chicago branch, left Sunday for a few weeks' rest at Grand Beach, Mich. Both of these popular talking machine men took along a complete set of fishing paraphernalia, and as Mr. Pilgrim has promised to distribute the results of his fishing efforts among his associates in New York, his work is cut out for him for the next two weeks.

A petition in bankruptcy was filed last week in the Federal Court by officers of the Artofola Talking Machine Co., Springfield, Ill. The liabilities were listed at \$22,863.86 and assets at \$20,400.

**FOR SALE
25 SHARES**

**Victor Talking Machine Co.
Common Stock
at \$725**

**WILLIS O. HEARD
LAFAYETTE BUILDING PHILADELPHIA, PA.**

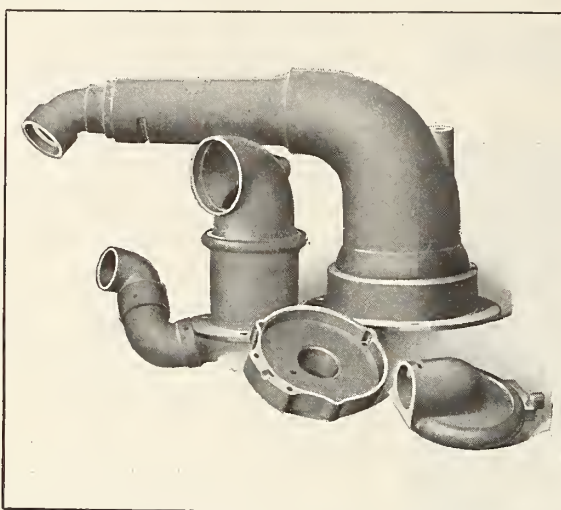

DOEHLER DIE-CASTINGS

for tone arms, sound boxes and talking machine attachments are STANDARD throughout the industry.

Of the many instruments produced to-day from the most prominent makes down, the greater number, by far, are equipped with Doehler die-cast tone arm and sound box.

The enormous output of our three large plants permits of advantages to the users of die-castings, as regards prices and deliveries, not otherwise possible.

DOEHLER DIE-CASTING CO.

MAIN OFFICE AND EASTERN PLANT
BROOKLYN, N. Y. NEW JERSEY PLANT
NEWARK, N. J.
WESTERN PLANT
TOLEDO, OHIO.

BUSINESS CONDITIONS NEVER BETTER IN PORTLAND, ORE.

Money Plentiful for Purchase of Talking Machines and Records, Owing to Growth of Shipbuilding and Thousands of Soldiers in the Camps—What Members of Trade Report

PORTLAND, ORE., July 5.—Business conditions in the talking machine field in Portland have never been better than in the last month. Dealers report sales as good as in the feverish holiday season and some of them are at a loss to account for the remarkable growth of sales as compared with the summer business of former years.

Unusual prosperity in this section, brought about, doubtless, from the enormous shipbuilding industry which in the last year has added more than 35,000 persons to the payroll in Portland and has added between 75,000 and 100,000 persons to the population, is given as the chief reason for the big growth of business. These high-paid workers are spending their money freely and talking machine dealers trace directly no little part of their increased sales to the shipbuilding industry.

Another potent factor in increasing business is the healthy condition of the lumbering industry, Portland's greatest asset. Millions of dollars are coming in each week from this source, the demand for spruce and fir lumber never having been so great.

Many thousand soldiers, it is not permitted to say how many, are stationed at Vancouver Barracks, Wash., just across the Columbia River from Portland, engaged in the work of getting out spruce for the Government airplane program. These men are paid, in addition to the \$33 from the Government as soldiers, the regular wage paid woodsmen, millworkers and lumbermen in private mills and the result is they have been spending freely of their comparative wealth. Not a barracks house at Vancouver but is supplied with its talking machine and the boys are ready purchasers of records and machines.

Still another factor which has had a noticeable effect on at least one branch of the industry is the loss of many stenographers in the big business houses. The Columbia Co. reports installing 125 dictaphones in the offices of the Oregon-Washington Railroad & Navigation Co. here to take care of the loss of stenographers. "Several of the shipyards have also ordered dictaphones," says L. C. Callahan, manager of the department at the Columbia.

Sales of Victrolas have been excellent at the

G. F. Johnson Music House and the record department, too, has been keeping up its end. Robert Callahan, manager of the Victrola department, is happy because for the first time in six months he has a complete stock of Victrolas on hand.

The Sonora phonograph continues to hold its own according to Thomas Wilkinson, manager of the Bush & Lane Co., sole agents here. Sonoras, Victors and Columbias have been selling well at the Bush & Lane house. James Loder, manager of the talking machine department, who has been suffering with a severe attack of grip, is recovering and is back at work.

The war has made further inroads into local talking machine staffs, and new material seems scarce. Patrick A. Murphy, one of the best salesmen of the Bush & Lane Co., is preparing to leave to fight for Uncle Sam. W. H. Schmidke, assistant manager of the Columbia Graphophone Co. here, has been taken in the draft, and has been replaced by Louis Older, a former member of the Canadian Army, who was wounded in service and was given an honorable discharge.

W. L. LeBanway, in charge of the phonograph department of the Graves Music Co., has gone to Camp Kearney, Cal., and has been succeeded by C. A. Newman.

B. B. Jones is now traveling for the local branch of the Columbia Co. He was formerly manager of the Spokane branch.

Several members of the Columbia Graphophone Co. staff, L. D. Heater, manager, L. C. Callahan, R. E. Haight and D. C. Kibble, went on a fishing excursion to Lewis River in Washington, and, they say, caught "lots of fish." Mr. Callahan made the biggest catch.

G. F. Johnson, head of the G. F. Johnson music house, has returned from New York City, where he attended the recent trade conventions, being the only representative from the Pacific Northwest. He visited Chicago, St. Louis, Denver and San Francisco on his way home.

Ervin Erenyi, of the G. F. Johnson music house, has severed his connections with that firm and is now with the Bush & Lane piano house. Mr. Erenyi is one of Portland's best-known salesmen.

E. B. Hyatt, proprietor of the Hyatt Talking Machine Co., says he did a splendid business in June, high-priced Victrolas, Edisons and Columbias having the preference. Miss Jessie Meighen and Miss Emma Reynolds have been kept very busy the past month in the record department. Mr. Hyatt says that business is so far ahead of that of last June that there is no chance for comparison. So good has business been that the firm has bought another fine new delivery truck.

Edison machines have been selling rapidly at the Meier & Frank store, J. H. Matney, depart-

ment manager, saying that business in talking machines has never been better than in the last month. The Meier & Frank Co. sends ten to fifteen records each month to the Red Cross, Camp Lewis, and the Spruce Division.

F. B. Travers, Northwestern manager of the Sonora Phonograph Corp., reports that business is fine all over the Pacific Coast. He is on his way to the factory in New York to push shipments to his territory.

The talking machine business has proved a big surprise to H. A. Calef, of the Calef Furniture Co. Last December Mr. Calef began selling Pathé machines and records. The big call for machines and the steady growth of the department was much more than Mr. Calef anticipated when he took a few machines at first as an experiment.

Mr. Calef says it is much easier to sell a Pathé than it is to sell furniture.

Twenty-five per cent. down is asked and obtained on all machines sold at the Seiberling & Lucas house. While fewer machines are disposed of at these terms than at the old 10 per cent. down figure. Frank Lucas says he finds the results are far more satisfactory. Sales of Brunswicks and Victrolas were unusually good in June and a great increase in the volume of records sold is reported.

Ten Brunswicks were sold in the month by the

Why Break Records? Just File Them!

That is if you have the wonderful Record filing system which is a feature of

The Marvelous MAGNOLA

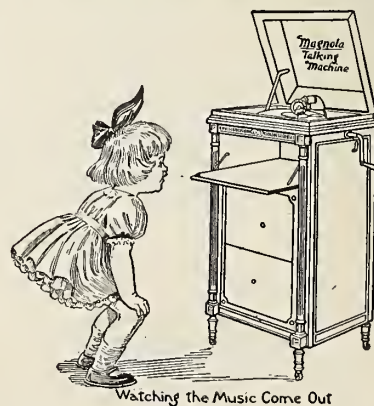

Watching the Music Come Out

This is only one feature of many that will command your interest and attention. Let us send you hand-some illustrated catalog and information as to our plans for helping you to make money with MAGNOLA.

MAGNOLA TALKING MACHINE COMPANY

OTTO SCHULZ, President

General Offices
711 MILWAUKEE AVENUE
CHICAGO

Southern Wholesale Branch
1530 CANDLER BLDG.
ATLANTA, GA.

"NICHOLSON" New Catalog Showing New Styles RECORD CABINETS

strictly high-grade construction at prices
BELOW COMPETITION

Write for a copy of the catalog and our
special free advertising help for dealers.

K. NICHOLSON FURNITURE CO., Chase City, Virginia
Sectional Bookcases and Record Cabinets

**Earl Fuller's Rector Novelty Orchestra—
Jockers Brothers—Marimbaphone Band—
Prince's Orchestra—snappy, catchy dance
hits by every one in the Columbia July
Dance Collection.**

**Columbia Graphophone Co.
NEW YORK**



Wakefield Music Co., which is mighty good for a small house with keen competition. C. Guy Wakefield, manager of the company, is making extensive alteration and enlargements, in fact, doubling the floor space.

C. B. Cordner, a prominent talking machine man of Portland, Ore., was not present at the last monthly meeting of the Portland Talking Machine Dealers' Association. The arrival of C. B. Cordner, Jr., on that evening detained the happy father. The little son is a fine, handsome boy.

The summer schools attended by teachers, which are numerous here, will have an opportunity of listening to Miss Elizabeth O'Connor, the educational representative of the Victor Co. Miss O'Connor will use the Victrola at the different schools and will endeavor to interest the teachers and show them the importance of the talking machine as an aid to the development of the practical as well as the artistic and musical studies in the Portland schools.

REPRESENTS WIDDICOMB IN EAST

P. Paul Graef Appointed This Week—Eastern Offices at 105 West Fortieth Street, New York

Announcement was made this week of the appointment of P. Paul Graef, president of the American Piano Bench Co., 105 West Fortieth street, New York, as Eastern representative for the Widdicomb phonograph, manufactured by the Widdicomb Furniture Co., Grand Rapids.

These phonographs are designed in Chippendale, Queen Anne and Adam periods, and are made in grand and upright models. They are equipped with a tone modulator and a Stephenson double spring motor.

SCARCITY OF STOCK THE GREAT PROBLEM IN DETROIT

Dealers Much Concerned About Securing Sufficient Stocks of Machines and Records to Meet Fall Demands—Purchasing Power of the People Increasing—The General Situation Reviewed

DETROIT, MICH., July 10.—The outlook for a scarcity of talking machines and even records this fall seems to be very apparent, and dealers now have become accustomed to such reports. They feel that no other condition can possibly prevail in view of the war, the tightening up of the labor and material markets for war production work. There is certainly a scarcity of certain models right at the present and this also applies to many records. Dealers do not complain because there is no demand for goods, but rather because they cannot secure the merchandise that is the greatest in demand. Every line of talking machines and phonographs has its best selling styles, and it is these styles that the manufacturers seem unable to supply in the quantities that dealers would like. From talking with dealers covering every make of talking machine we know their stock is none too big and that the chances for them getting increased shipments are most remote, unless the unexpected should happen. Of course, right now, dealers are not so worried because July and August are always the dull months of the year, but they are hoping that something could be done to assure them of merchandise next fall when business always picks up. October, November and December are the best months naturally for the talking machine dealers, and yet the jobbers are not holding out any encouraging news for those months. "We would be glad to fill your order if we had the merchandise, but under the circumstances we can simply say to you we are sorry and that we will fill your order as soon as the goods come in." These words are typical of what is contained in letter after letter written by jobbers to dealers.

C. H. Grinnell, manager of the wholesale division of Grinnell Bros. talking machine department, is one jobber who does not mince words about the situation, and he believes it would be a whole better for the industry if there was more frankness in expressions by manufacturers, jobbers and retailers regarding the seriousness of the situation.

The furniture exhibition, or exposition, at Grand Rapids in the month of July has been

attracting many hundreds of retailers from all parts of the country, and the event has proven profitable for a number of talking machine manufacturers who have displays with men in charge. Burton Colver, of the Cheney Talking Machine Co., was among those who arrived in Grand Rapids early, and whose firm, by the way, has a permanent exhibit in the furniture city.

R. B. Alling, of The Phonograph Co., is adding new retailers right along out of the Detroit territory, and anticipates a big improvement in business after the first of September.

Ed Andrew, of the J. L. Hudson talking machine department, attended the music show in New York City during the month of June. The Hudson store is short on Nos. 11 and 14 model Victrolas.

Wallace Brown, the Brunswick dealer in Detroit, says that June was actually a much better month than he had anticipated, and that in going over the books he beat June of a year ago. Mr. Brown now operates a branch in the Polish district of Detroit, which is doing a good business.

Charles Smith, of the Detroit Music Co., Columbia dealers, says that June was a better month than May, and that both machines and records sold well.

J. H. Goldberg, the Gratiot avenue, eastside dealer, is still doing a very large business in foreign records. He is the biggest customer of the local wholesale office of the Columbia Co. on foreign records. Mr. Goldberg has always made a specialty of this class of business.

This is vacation season and in making the rounds we found a great many department managers and dealers on their annual vacations.

We hope in our next letter to report more encouraging conditions in the local field. We reiterate that there is a good demand for talking machine products and that the greatest difficulty is to get them from the jobbers and manufacturers.

The cabinet-making plant of W. C. Green & Son, Loveland, Col., has been purchased by the Jackson Phonograph Co., for the purpose of manufacturing talking machines.

The Mutual
—TONE ARMS & SOUND BOXES—

**Place Your Orders
TO-DAY
for**

Mutual

**TONE ARMS AND
SOUND BOXES**

"Mutual Products Have Made Good"

Mutual Talking Machine Co., Inc.
145 West 45th Street, New York

KIMBERLEY PHONOGRAPH SUPPLY CO.

We are now ready to offer the trade a complete line of high-class machines, retailing at \$40, \$60, \$100, \$125, \$150, \$200 and \$250. Every machine is guaranteed in every detail, and this house has a recognized financial and credit standing. Immediate deliveries guaranteed. Write today for further details.

Eastern jobbers for Thomas Dayton Motors, Tone Arms and Sound Boxes. Complete stocks always on hand. Prices quoted f. o. b. New York

206 Broadway, New York

W. Brand, Manager

- ALABAMA.**
Anniston.
Birmingham.
Dotban.
Mobile.
Montgomery.
Selma.
- ARIZONA.**
Naco.
Flagstaff.
Phoenix.
Noales.
Tucson.
Yuma.
- ARKANSAS.**
Helena.
Fort Smith.
Jonesboro.
Little Rock.
North Little Rock.
Pine Bluff.
Texarkana.
- CALIFORNIA.**
Antioch.
Bakersfield.
Calexico.
Cedarville.
El Centro.
Eureka.
Fresno.
Hayward.
Hemet.
Hollister.
Indio.
Los Angeles.
Loyalton.
Oakland.
Modesto.
Monterey.
Oxnard.
Napa.
Placerville.
Sacramento.
San Bernardino.
San Diego.
San Francisco.
San Jose.
Santa Ana.
Santa Rosa.
Stockton.
Sallinas.
Susanville.
Vacaville.
Watsonville.
- CONNECTICUT.**
Bridgeport.
Hartford.
New Haven.
Waterbury.
Wilmington.
- DELAWARE.**
Dover.
Georgetown.
Wilmington.
- DIST. OF COL.**
Washington.
- FLORIDA.**
Miami.
Jacksonville.
Key West.
Pensacola.
Tampa.
- GEORGIA.**
Augusta.
Atlanta.
Brunswick.
Columbus.
Savannah.
Macon.
Rome.
- IDAHO.**
Boise.
Nascow.
Pocatello.
St. Anthony.
Twin Falls.
- ILLINOIS.**
Alton.
Aurora.
Bloomington.
Cairo.
Chicago 8.
Danville.
Decatur.
East St. Louis.
Galesburg.
Joliet.
La Salle.
Peoria.
Pontiac.
Quincy.
Rockford.
Rock Island.
Springfield.
- INDIANA.**
Evansville.
Fort Wayne.
Indianapolis.
North Bend.
Terre Haute.
- IOWA.**
Cedar Rapids.
Council Bluffs.
Creston.
Davenport.
Des Moines.
Forest City.
Marion.
Mason City.
Ottumwa.
Sioux City.
Waterloo.
- KANSAS.**
Ablene.
Dodge City.
Hutchinson.
Kansas City.
Parsons.
Topeka.
Wichita.
- KENTUCKY.**
Asbland.
Louisville.
Covington.
Henderson.
Lexington.
Newport.
Paducah.
- LOUISIANA.**
Alexandria.
Baton Rouge.
Jennings.
Monroe.
New Orleans.
Shreveport.
- MAINE.**
Augusta.
Bangor.
Portland.
- MARYLAND.**
Baltimore 4.
Cumberland.
Hagerstown.
Salisbury.
- MASSACHUSETTS.**
Boston 4.
Springfield.
Worcester.
- MICHIGAN.**
Detroit.
Grand Rapids.
Port Huron.
- MINNESOTA.**
Minneapolis.
St. Paul.
- MISSISSIPPI.**
Ackerman.
Greenwood.
Gulfport.
Hattiesburg.
Jackson.
Meridian.
Pascagoula.
Vicksburg.
West Point.
- MISSOURI.**
Hannibal.
Kansas City.
Jefferson City.
St. Charles.
St. Louis 2.
Sikeston.
- MONTANA.**
Billings.
Butte.
Glasgow.
Great Falls.
Havre.
Helena.
Lewistown.
Miles City.
Missoula.
- NEBRASKA.**
Hastings.
Lincoln.
North Platte.
Omaha.
- NEVADA.**
Gardnerville.
Reno.
- NEW HAMPSHIRE.**
Berlin.
Dover.
Franklin.
Manchester.
- NEW JERSEY.**
Atlantic City.
Camden.
Gloucester City.
Jersey City.
Newark.
Orange.
Paterson.
Trenton.
- NEW MEXICO.**
Albuquerque.
Deming.
Roswell.
Santa Fe.
- NEW YORK.**
Buffalo.
N. Y. City 16.
Rochester.
Syracuse.
- N. CAROLINA.**
Charlotte.
Elizabeth City.
Kinston.
Monroe.
Newbern.
Raleigh.
Wilmington.
- N. DAKOTA.**
Bismarck.
Fargo.
- OHIO.**
Akron.
Athens.
Canton.
Cincinnati.
Cleveland.
Columbus.
Dayton.
Hamilton.
Lima.
Mansfield.
Marietta.
Marion.
Portsmouth.
Sandusky.
Springfield.
Stuebenville.
Tiffin.
Toledo.
Washington.
C. House.
Youngstown.
Zanesville.
- OKLAHOMA.**
Ardmore.
Ehid.
Hobart.
Lawton.
McAlester.
Muskogee.
Oklahoma City.
Tulsa.
- OREGON.**
Astoria.
Eugene.
Medford.
Pendleton.
Portland.
- PENNSYLVANIA.**
Allentown.
Altoona.
Chester.
Erie.
Harrisburg.
Johnstown.
New Castle.
New Kensington.
Oil City.
Philadelphia 6.
Pittsburgh 2.
Reading.
Scranton.
Williamsport.
York.
- RHODE ISLAND.**
Providence.
- S. CAROLINA.**
Charleston.
Columbia.
Marion.
Sumter.
- S. DAKOTA.**
Huron.
- TENNESSEE.**
Chattanooga.
Clarksville.
Columbia.
Copper Hill.
Jackson.
Knoxville.
Memphis.
Nashville.
- TEXAS.**
Amarillo.
Austin.
Beaumont.
Brownsville.
Dallas.
El Paso.
Fort Worth.
Galveston.
Houston.
Laredo.
Paris.
San Antonio.
Smithville.
Waco.
- UTAH.**
Logan.
Ogden.
Salt Lake City.
- VERMONT.**
Bellows Falls.
Burlington.
Montpelier.
Rutland.
- VIRGINIA.**
Alexandria.
Danville.
Lynchburg.
Newport News.
Norfolk.
Richmond.
Roanoke.
- WASHINGTON.**
Aberdeen.
Bellingham.
Everett.
North Yakima.
Seattle.
Spokane.
Tacoma.
Walla Walla.
Wenatchee.
- W. VIRGINIA.**
Charleston.
Johnstown.
- WISCONSIN.**
Greer Bay.
La Crosse.
Madison.
Milwaukee.
Oankosh.
Superior.
- WYOMING.**
Cheyenne.



Need Men?

Let's look in these 400 Branches FIRST!

Before you make a move to hire men see what men the Government can find for you.

On the map are spotted the 400 offices that the Government has established for this one purpose of helping manufacturers find men.

They blanket the country. And in addition there are 20,000 U. S. Public Service Reserve agents who reach down into every little hamlet where there is labor to be had.

U. S. Employment Service makes no charge for its service. It is supplying the labor for the shipyards. It is supplying a daily growing number of manufacturers working on war orders. It is the one way to reduce the labor turnover and increase production. Use it when YOU need men.



United States Employment Service

U.S. Dept of Labor
W.B. Wilson Secy

Contributed through Division of Advertising

U. S. Gov't Comm. on Public Information



This space contributed for the Winning of the War by
THE TALKING MACHINE WORLD

CROIX DE GUERRE TO W. G. PORTER

Former Member of New York Talking Machine Co. Staff Covers Himself With Glory

Roy J. Keith, vice-president and general manager of the New York Talking Machine Co., Victor wholesaler, received word this week that W. G. Porter, formerly one of Mr. Keith's executive assistants, had received the Croix de Guerre for bravery under fire.

Mr. Porter left for France last year as a member of the Princeton Ambulance Unit, and since



W. G. Porter

that time has seen active service "over there." Full details regarding his winning of the Croix de Guerre have not yet been received in New York, but many of the New York Talking Machine Co.'s staff predicted long ago that "Bill" Porter would cover himself with glory if given a chance to see active service in France.

THRIFT STAMPS IN ADVERTISING

I. Riesenburger, of Flushing, Gives Thrift Stamps for Tinfoil to Be Donated to Red Cross—Gave Away 800 Stamps at Opening

I. Riesenburger, who operates two furniture stores with large Victrola departments in Flushing, N. Y., and an exclusive Victrola store in Bayside, is showing an excellent business and patriotic spirit by presenting a Thrift Stamp to every child bringing a pound of tinfoil to his store. The plan has proven most interesting to the children, and there are dozens of them engaged in collecting the foil. Incidentally, the interest of the parents has also been aroused, and the sale of machines and records has been stimulated thereby. On September 10 Mr. Riesenburger will present \$10 worth of Thrift Stamps to the child who has turned in the most pounds of tinfoil, and will also give a second prize of \$5 for the second largest amount. He expects to collect at least a ton of tinfoil, which he will donate to the Red Cross at a special Red Cross celebration to be held on September 15. Mr. Riesenburger is a great believer in the value of Thrift Stamps for advertising, and at the recent opening of his new store at 36 Main street, Flushing, he presented a Thrift Stamp to each visitor who registered; 800 stamps were given away on the opening day and an excellent prospect list thus accumulated.

Joseph F. Higgins, purchasing agent of the Otto Heineman Phonograph Supply Co., returned recently from a visit to the company's factories at Springfield, Mass., and Putnam, Conn., where the company's record, plant and Dean needle factories are located, respectively. While in New England Mr. Higgins took advantage of the opportunity to place a number of orders for materials and supplies that will be needed by his company the coming year.

INTRODUCE NEW TONE ARM

Parr Mfg. Co. Announce the Parr Central-Universal Tone Arm—Its Features

The Parr Mfg. Co., New York, manufacturers of the Parr magnetic reproducer, announce that they are now ready to send samples of a new universal tone arm of their own make which embodies a number of exclusive features. It is to be known as the Parr central-universal tone arm, and it is stated by those connected with the company that the new product will play either the lateral cut or hill and dale type of records without any additional attachments. Mr. Parr, president of the Parr Mfg. Co., in speaking of their new tone arm, said: "We decided some time ago to manufacture a tone arm of our own make, which would not only be a valuable adjunct to the Parr reproducer, but could also be used for sound boxes of other makes. However, our decision was only in answer to the large number of requests we have received from time to time from manufacturers who are now using the Parr magnetic repro-

ducers and who are desirous of getting an entirely new tone arm."

Mr. Parr stated that some of the exclusive features of their tone arm were: "The fact that it is adjustable to any length required—the position of the needle which is always at the same point in playing either type of record—and the ability of the tone arm to take up any wear, thereby overcoming the tendency for loose joints, which is one of the chief causes of chattering."

The Parr central-universal tone arm is of very artistic design and many orders have been booked from manufacturers who have been using the company's reproducers.

OGDEN SECTIONAL CABINET LIKED

Judging from the way orders are reaching J. B. Ogden, of Lynchburg, Va., there is an increasing appreciation evident of the merits of the Ogden sectional record cabinet and sales system. Despite shortage of stock and labor Mr. Ogden is filling orders without any serious delay.

LYRIC RECORDS

Are Different!

Because:

- 1. They are more musical**
- 2. Of their wonderful natural tone**
- 3. There is no scratch**

This should appeal to you, Mr. Jobber, and to you, Mr. Dealer, because these are the qualities demanded by the discriminating and up-to-date purchaser of phonograph records.

LYRIC RECORDS can be played without an attachment on all machines equipped with the universal tone-arm; and on old-style machines, by using a standard attachment.

The **LYRIC CATALOGUE** includes all that is best in the world's literature of standard songs, operatic arias, instrumental solos, band and orchestra records, etc.

New Bulletins issued monthly, giving the best of the new song hits and dances.

JOBBERS write for terms and full information.

DEALERS write for catalogue and name of the wholesale distributor for your district.

Immediate Deliveries in Any Quantity



LYRAPHONE CO. OF AMERICA
 12-14 West 37th Street - - - - New York, N. Y.

BALTIMORE A BUSY TALKING MACHINE TRADE CENTER

Business Excellent, But Trade Somewhat Retarded Through Lack of Sufficient Stock—Changes in Sales Staffs, Owing to Draft—Columbia Dealers Meet—What the Trade Reports

BALTIMORE, Md., July 5.—Talking machine business is showing to good advantage with the majority of dealers in the retail lines, but the jobbers for the most part are still sounding the "shortage of goods" story. Meanwhile the shortage of goods is getting to be more or less chronic with some of the dealers, yet despite lack of goods they are showing very good results on the ledger, and would be able to add materially to their profit and sales if they could get all of the goods they could sell.

Several of the Baltimore dealers have received word of the action of the Pittsburgh dealers' association banning all records that have any semblance of German, and some have even gone so far as to ban all records by German composers. No action will be taken by the Music Dealers' Association as a body on this line until the fall meeting, but without any concerted action dealers have boxed up their German records and interned them, as it were. So few German records are being kept by some of the firms in the stock, that customers find it difficult to procure them to-day. There has been a big run on Bohemian, Italian and Greek records here and one of the firms making a specialty in international records has been doing a very fine business.

Patriotic records have the call with most of the firms, and many of the old-time records that have been in stock for a long time are now being sold without any trouble. Those firms that are fortunate enough to carry two lines have been able to make virtually a killing in record sales, because what one line has been lacking the other has had.

W. C. Roberts, for E. F. Droop & Sons Co., Victor wholesaler, reports that June has gone 30 per cent. ahead of the same month a year ago. Both machines and records, especially the back number records, have been coming in very well recently, and Mr. Roberts says that they will continue to come in. Victrola 11, the \$115 machine, is selling very well, and Victrola 16, the \$225 machine, is having the call. Mr. Roberts spent several days at the factory during the month and was rewarded by having more machines come to him. Jack Bowen, in charge of the company's record department, made a trip to the factory for back records and evidently accomplished his mission, for stock has been coming in very good. He is now motoring in Virginia. Morris Kirch, of the sales staff, motored through Pennsylvania for his vacation and is back on the job. William Reiser, of the sales staff, is at Atlantic City, and Miss Sadie Thompson, chief bookkeeper, leaves for Atlantic City this week.

For the Columbia Graphophone Co., W. S. Parks, manager of the Baltimore and Washington branches, showed an increase over last June, but not as great as he would have liked to have it. This, he says, was due to the fact that he was not able to get as much goods as he could place. He was at the factory and at the general offices of the company in New York and made a big effort to get more goods.

O. F. Benz, of the general sales manager's office of the Columbia Co., made an address to the salesmen of the local offices, and T. J. Porsky, of the international record department,

New York, was in Baltimore for two weeks working up this department.

Mr. Parks made a trip through eastern Virginia and came back optimistic over business conditions in the section. Lyman Bryan, who for many years was identified with the sale of automobiles, has joined the city sales forces, and W. T. Sibbett is in charge of the western part of Virginia, succeeding William Korhammer, who is now in service.

Another meeting of Columbia dealers was held during the month, and Van & Schenck, who were appearing at the Maryland Theatre, spent several hours entertaining the Columbia folks at their headquarters. There were 112 persons on hand and all were made thoroughly happy. A platform that can be put up and taken down in sections has now been made, and after Van & Schenck concluded their entertainment Mr. Parks brought out some of the August records and obtained dealers' opinions on them. Later all hands took part in dancing for more than an hour. Among the visitors to the Columbia Co. during the month were J. E. Friedburg, of the Virginia Mercantile Co.; Emmet Thompson, Warsaw, Va.; B. H. Sommers, Ellicott City, O.; R. L. McDowell, of H. C. Grove, Inc., Washington, D. C.; E. K. Staley, of the Van Wickle Piano Co.; J. P. Roller, Luray, Va., and J. W. Legun, Berkeley Springs, Va.

A. P. Petit, who came into the talking machine business almost a score and a half years ago, is in charge of the Baltimore headquarters of the Brunswick-Balke-Collender Co. He is optimistic over his new line and expects big things to come out of it. He says he is only opening a few accounts and is seeking only high financial corporations to handle the line. Machines have started to come in fairly well, but he could use more than he is getting. Two new accounts have just been added by the company, these being the O'Dell Hardware Co., Greensboro, N. C., and the Phelps Armistead Co., Roanoke, Va.

I. Son Cohen, of Cohen & Hughes, Inc., reports a good retail business, but the wholesale business is being held back because of lack of goods. June this year did not reach the mark of the previous year during the same period. Mr. Cohen is just back from a two weeks' vacation in the Green and White Mountains, and is plunged into hard work. H. M. Little, in charge of the retail department of the Cohen & Hughes, says June exceeded expectations, and that the buyers were of a better class than they had been handling for some time.

Jesse Rosenstein, of the National Piano Co., Pathé distributor, reports very satisfactory business with his line with goods coming in better. The firm has just taken on another building on Howard street, across from their present showrooms. The new building will give the firm much increased space and permit of better displaying of goods.

Miss Mary Haas has been placed in charge of the talking machine department of The Leader, Columbia dealers. Miss Haas succeeds Charles Cahn, one of the sons of the proprietor of the store, who has enlisted and is now working for the Emergency Fleet Corp.

Miss Henkel has become manager of the talking machine department of the Frank J. Murphy Co., Columbia dealers, and succeeds W. C. Collins, who is now doing his bit for Uncle Sam. Business with the firm is reported as good. Harry C. Heise, manager for the Hampden branch of S. & N. Katz, jewelers, who have a large talking machine department, made a very unique sale last week. On Saturday nights he places a young man on the second floor of the store with an old type of machine, using a large horn, and the young man keeps the latest records playing continuously. A man entered the place and wanted to know what the machine was worth that he heard playing. He was told that it was an old style out of date model. "That makes no difference to me," the pros-

Yahr & Lange Drug Co.
MILWAUKEE, WIS.

Wholesale Distributors for

THE INSTRUMENT OF QUALITY
Sonora
CLEAR AS A BELL

in Wisconsin
and Upper Michigan

pect remarked, "because I'm deaf and that is the first machine that I have been able to hear." He bought the machine and carried it home, declining to have it sent for fear he would not get the same one.

M. Budazc, 1744 Eastern avenue, is the latest Columbia dealer to be signed up. This store is in the center of the Polish and Lithuanian settlement of Baltimore, which numbers about 35,000, and it is the belief of the Columbia people that it will prove an exceptionally good place for the international records.

Henry Eisenbrandt, of H. R. Eisenbrandt & Sons Co., Victor distributors, reports good trading in the retail department, but a tremendous falling off in wholesale because of his inability to obtain the necessary goods.

AN INCREASE OF 115 PER CENT.

Reported by Manager Friedl, of the New York Branch of the Columbia Graphophone Co.

In a chat this week with The World Lambert Friedl, manager of the New York branch of the Columbia Graphophone Co., stated that the sales totals of this branch for the month of June showed an increase of 115 per cent. over last year. This is all the more remarkable in view of the fact that the New York headquarters have received only a very small percentage of the Grafonolas they have ordered, and on July 1 Mr. Friedl had but nine machines in stock. He states that the demand for Columbia products in this territory is increasing by leaps and bounds, and that it is almost impossible to keep pace with the requirements of the dealers. Mr. Friedl points with pride to the fact that his branch has given the dealers 95 per cent. service in filling their record orders. An active campaign is now under process of formation, whereby the famous Pershing record will be the subject of extensive publicity in all local advertising mediums.

Through the good work of the Temple Women's Association of Cleveland more than 1,500 talking machine records have been sent to the camps in the eastern part of the country. It is planned to send machines and records to the soldier boys at widely separated points so that they may be well supplied with music.

W. F. Peaker has opened a store at Hampton, Ia., to sell talking machines and pianos.

MAESTROLA MAHOGANY CABINET MACHINES, SIZE 15 x 15 x 7½

Motor worm gear plays 2½ to 3 ten inch records, one winding. Price in dozen lots \$5.00 each, sample machine \$5.50.

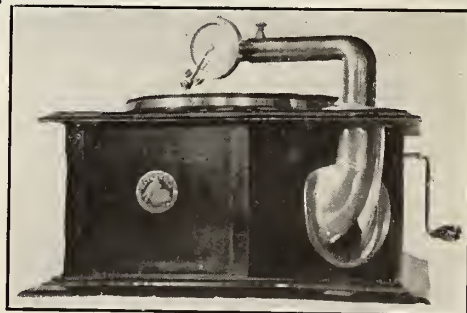

Steel needles and phonograph parts selling at the old prices during July regardless of the scarcity of these supplies. Now is the time to place your order. Be wise and save money.

FULTON TALKING MACHINE COMPANY
640 Broadway New York City, N. Y.

DEALERS EVERYWHERE ARE SELLING
QUANTITIES OF OUR

HANAIE BANJUKES

(Ukuleles in Banjo Form)

A bigger hit than the Ukulele because much louder and more pleasing in tone, and of more substantial construction. Perfect two octave scales. A thoroughly practical instrument for both solo playing and club work. Send for illustrated catalogue and price list today, as

The Banjoke Is One of the Biggest Sellers in the Musical Instrument Line.

SHERMAN, CLAY & CO.

Sole Manufacturers

163 Kearny Street San Francisco

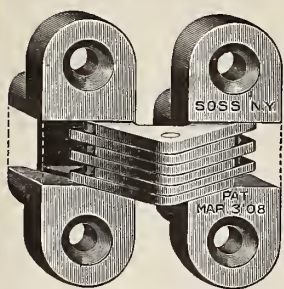

No. 103

SOSS

INVISIBLE HINGES

Preserve Beauty

In many beautifully designed, finely finished Talking Machines, Pianos, Music Cabinets, Piano Players and Benches, the elimination of the unsightly protruding Hinge is essential to preserve the beauty of the design.

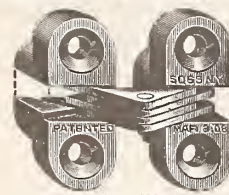

No. 100

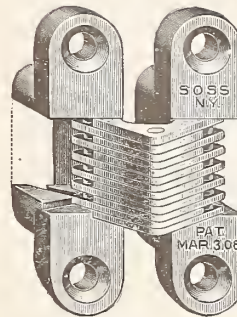

No. 101

Design and Construction

The fine cabinet work which is required in many instances to preserve the disguise of the instrument requires that the hinges be as inconspicuous as possible. SOSS Hinges are *invisible*.

WRITE FOR CATALOGUE "T"

SOSS MANUFACTURING COMPANY, 435 Atlantic Avenue, BROOKLYN, N. Y.

DETROIT—922 David Whitney Bldg.
SAN FRANCISCO—164 Hansford Bldg.

LOS ANGELES—224 Central Bldg.
CHICAGO—John C. Bold & Co., Clark and Washington Sts., Conway Bldg.

APPROVE CASH PAYMENT BASIS

Yahr & Lange Co. and Others Write Approvingly of Geo. E. Brightson's Views on Merchandising Phonographs on Cash Payment Basis

George E. Brightson, president of the Sonora Phonograph Sales Co., received this week an interesting letter from the Yahr & Lange Drug Co., Milwaukee, Wis., Sonora distributors, congratulating Mr. Brightson upon the success of his efforts to impress upon the trade and the public the importance of merchandising phonographs on a cash payment basis. Mr. Brightson has worked indefatigably in behalf of this policy, and his work is now bearing fruit.

One section of this letter read as follows: "You are certainly doing wonders to bring the phonograph business to the front in the proper way, and we have tried to exercise your cash payment plan with our dealers as much as possible, and you would be surprised to note the small quantity of instruments our dealers have out on time payment. We called on two or three of our best dealers to-day, who have sold in the neighborhood of \$5,000 to \$6,000 worth of Sonoras, and none of these dealers had over three instruments out on time payment out of their entire sales. They have advised me that they seem to have no difficulty in selling Sonoras for cash, as we have very little of the department store trade to contend with, which sells a phonograph on the \$1 down and \$1 a week plan. Keep up your good work, Mr. Brightson, as you are on the right road."

Another letter received this week by Mr. Brightson from a successful Sonora jobber will give a fair idea of the tremendous demand for Sonora phonographs in the East. This letter reads in part as follows: "Our salesman started on a little trip to give him something to do, and make up expenses for himself and wife. He started last Monday, and up until yesterday he

turned in \$8,100 net business, and all business that we could handle and ship right out. He writes that he can sell anything that can be delivered immediately, as the dealers have no stock in hand, and want the instruments at once.

"What we must have and have now and quickly, are more 'Imperials' and 'Intermezzos' on our orders—no quantity too large, as we can sell 'Imperials' without half trying at \$135, while the 'Intermezzos' are in demand everywhere. Also give us a shipment of 'Fantasies' as quickly as possible, and above all 'Baby Grands' in carload lots. This is not a jest, for we can use right this moment two hundred 'Baby Grands,' and ship every one of them out as fast as the railroads and express companies will carry them. Do the best for us you can, and rush the 'Imperials,' 'Intermezzos' and 'Fantasies,' and as many 'Baby Grands' as you can. We did not receive our share of these—at least it seemed so to us, and our many dealers are saving their money to buy these 'Babies' as soon as we get them."

SHIPPING TONS OF NEEDLES

The Brilliantone Steel Needle Co. are now measuring some of their shipments in tons. A recent order which left their headquarters in the Marbridge Building, New York City, weighed five tons. A duplicate of this order is scheduled to leave within a week. L. Unger, formerly connected with Joseph W. Stern & Co., was recently added to the sales staff of the organization and is already sending in favorable and acceptable communications from the Middle West, where he is now traveling. He sent in an order for four million needles on the first day out.

The Denver Music Co. reports an increasing demand for the Victor and Columbia machines in its territory.

FRIEDA HEMPEL ON PHONOGRAPHS

In a Recent Interview the Well-Known Artist Gave Expression to Opinions Regarding Accomplishments of That Instrument—Offers Interesting Plan to Raise Musical Taste

A most interesting and stimulating interview with Frieda Hempel, the famous opera star, and Edison artist, who recently secured American citizenship through marriage with a prominent American business man, appeared recently in the Musical Leader. In the course of the interview Miss Hempel paid high tribute to the phonograph and the re-creation of music through that means in the development of the musical traditions of the country. She pointed out that the phonograph has carried much of the message of music into the farthest corners of the country and accomplished results undreamed of a few years ago even by the most enthusiastic.

Incidentally, Miss Hempel gave an interesting suggestion looking to the taste for ragtime to Miss Lois Willoughby, who interviewed her. "Do you know how I would raise a person's taste in music?" she asked. "If he liked ragtime I would give him all he wanted—I'd give him ragtime records until he never wanted to hear one again. And I'd tuck a few of the classics in along with them—not designated as classics, please—and I'd be perfectly willing to trust to results. There is one thing about the classics and about traditions—they stand the wear and tear, even of a phonograph, and I don't care who plays it."

A. F. Meisselbach, vice-president of the Otto Heineman Phonograph Supply Co., was the subject of an interesting tribute from the pen of James R. O'Neill in the New York Sun of Sunday last. His skill as a disciple of Izaak Walton and his popularity were dwelt upon.



MODEL 100

SONA-TONE

A Phonograph of Distinction with the Tone You Can't Forget

SONA-TONE *Quality* means a resonant, full, liquid tone that comes from an especially designed, all-wood sound chamber—and superior workmanship in material, finish and equipment.

SONA-TONE *Reliability* means simplicity of mechanical construction—ease of operation—and convenience and solidity of working parts.

SONA-TONE *Service* means the immediate ability of the purchaser to play all makes of records—without attachment of any sort—and to play a library of from 250 to 1000 assorted records without further expenditure.

We believe that a Sona-Tone eliminates—to a greater extent than any other phonograph—the surface noises of the record.

We believe that it has the same quality of resonance as exists in the Stradivarius violin.

From our sales record—previous to advertising—we believe that a SONA-TONE is a superior phonograph for retail merchandising.

SONA-TONE PHONOGRAPH, Inc.

3421 Broadway, New York City

\$35, \$70, \$100, \$150, \$200, \$250

"The music is on the record—the tone is in the phonograph."

NOTED CAREER IN RECORD FIELD

John Fletcher, General Manager of the Operaphone Co., Has Had Interesting Experiences in the Musical and Recording Worlds

In a recent interview with The World John Fletcher, general manager of the Operaphone Co., Long Island City, N. Y., gave an interesting account of his experiences in the musical and recording worlds.

"My first phonographic experience," said Mr. Fletcher, "was as a player in the old Edison cylinder laboratory in Orange, N. J., when you had to get up at 5 o'clock in the morning, be on the job, in your chair, and ready to play at 8 o'clock."

"Being of a mechanical turn of mind I soon realized the difficulties that had to be surmounted in order to record high-class music. I heard considerable talk in those days about the acoustical requirements for sound recording, consequently there was not a concert hall, theatre, or large pavilion in which we played, either in America or Europe, that I did not study the acoustical principles used to promote sound amplification."

"On my return from Europe I immediately joined the New York Symphony Orchestra as a player, with the sole object of studying intimately the world's musical masterpieces and the tonal effects of the symphony orchestra. During this time I realized how imperfect were the methods then in vogue to record symphonic music with a few instruments, and I finally resolved to devote my future career to recording the various instruments comprising the grand orchestra, in sufficient numbers to produce the musical sensation caused by the combined tonality of such a large number of instruments."

"I finally succeeded in developing a steel needle up and down cutout disc record of materially the same dimensions in width and depth of cut as the steel needle lateral cut record. I applied for patents covering such improvements that had been developed, and in 1914 founded the Operaphone Co., which produced a seven-inch record that retailed for 25 cents. Soon afterward we saw the possibilities of applying this principle of cutting to a larger record, and therefore abandoned the seven-inch record, and recorded a catalog of 200 numbers in eight-inch size."

"After several years of this pioneer struggling, and after facing abnormal conditions, due to the steadily increasing prices of raw materials, the Operaphone Co. seized the psychological moment to shut down its factory, reorganize the company, and make the necessary mechanical changes incidental to manufacturing and plac-

ing on the market a standard ten-inch catalog of 300 selections. This catalog is now in the hands of the dealers throughout the country, and is helping to supply the existing and fast-growing demand for a standard sized record which will play on all Universal tone arm machines with a steel needle, for it is my firm conviction that the steel needle up and down cut produces the greatest amount of tone color with the least amount of surface noise."

"Now that we have completed this standard commercial catalog, I am planning to devote more time to the inspiration that influenced my entering the phonograph field—the recording of the entire symphonic repertoire. This appeals to me as the most fascinating and interesting means of musical expression, and it is the least understood, principally because the great music-loving public has not had sufficient opportunity to hear music's masterpieces presented in their true form. It is my hope and desire that through the medium of Operaphone records I will be able to bring the symphonic orchestra into the homes of many who have not previously had the advantage of hearing these wonderful orchestral organizations."

SUGGEST NATIONAL ASSOCIATION

Talking Machine Men, Inc., Sounds Out Other Organizations Regarding the Plan

The Talking Machine Men, Inc., the organization of retail talking machine dealers in New York, New Jersey and Connecticut, has, through its secretary, E. G. Brown, been sounding out existing associations of talking machine dealers in other sections of the country, regarding the possibility of organizing a National Association of Talking Machine Dealers. Up to the present time enough replies have not been received to warrant any predictions as to the extent of the movement.

FOREIGN RECORDS NOW AVAILABLE

The international record department of the Columbia Graphophone Co., R. F. Bolton, sales manager, has made arrangements whereby gems and novelties from the Columbia catalogs of foreign-language records will also be included in the regular domestic catalog; it being planned to offer these records with the regular "E" series green label, thereby making the record distinctive and different in appearance from the general domestic records.

The first record to be announced in this new plan will be an interesting record made by a native Serbian Tamburiza String Orchestra; a unique organization consisting of five tamburizas (a flat mandolin) and a violin. The record made by this orchestra will feature two selections, including the Kosovo waltz, which commemorates the great Serbian-Turkish battle of Kosovo, 1389, that symbolized the freedom the Serbians finally won over five hundred years later. It is played by all Serbians on the anniversary day once a year, and this record has the same tempo as the American waltz plus native atmosphere.

Judging from the tremendous demand for foreign-language records, the idea of featuring a record from this catalog each month in the general domestic catalog will doubtless meet with popular favor throughout the country. There are included in the Columbia library many well-known organizations making foreign-language records, and this additional listing will doubtless act as a marked impetus to the sale of these records.

NEW DEPARTMENT NEARLY READY

The new talking machine department of the Meiklejohn Co., Providence, R. I., under the management of A. W. Waite, is now practically completed. The new department will have several soundproof demonstrating rooms, modern record filing system, and commodious display space for the Edison and Starr machines. It will be admirably equipped in every way.



Record Cabinets
Record Envelopes



PIANO CREAM

is wonderful for Talking Machines. It is made especially for cleaning, polishing and restoring the lustre to the very best kind of a finished surface. It contains no turpentine, vinegar, linseed oil, butter of antimony, wax, coal oil, no acid or chemical to injure surface. It will make the Talking Machine look as good as new.

Write for prices

CLEMENT BEECROFT 309 W. Susquehanna Ave. PHILADELPHIA

Advertisement for record cabinets and envelopes, including a diagram of a cabinet and a list of 'Thirty desirable records' with details like 'INSTRUMENTAL' and 'VOCAL' categories.

Lots of good window-display material ready for you on the timely Vacation Grafonola Drive. Better send for some.

**Columbia Graphophone Co.
NEW YORK**



DEALERS HEAR LASHANSKA SING

New Columbia Star Entertains Columbia Dealers at Recent Monthly Gathering in New York

The June meeting of Columbia dealers in metropolitan territory was held late last month in



Mme. Hulda Lashanska

the Astor gallery of the Waldorf-Astoria Hotel under the auspices of the local Columbia wholesale branch. Lambert Friedl, manager of this branch, who was in charge of this meeting, prepared a very interesting program.

The most interesting feature of the meeting was the introduction to the dealers of Mme. Hulda Lashanska, a recent addition to the Columbia recording library, who will make records for the Columbia Co. exclusively. Mme. Lashanska has achieved success on the concert stage, having appeared as a soloist at Aeolian Hall, Carnegie Hall and the Metropolitan Opera House. She has also been heard with the Philharmonic Orchestra, New York Symphony Orchestra, Cincinnati Orchestra, and every well-known orchestra throughout the country.

At this meeting Mme. Lashanska rendered several selections which emphasized the fact that she is entitled to recognition as one of the leading sopranos now appearing on the concert stage. Her first Columbia record will be announced next month.

Two other Columbia artists who appeared at this meeting were Robert Lewis, the well-known tenor, and Evan Davies, baritone, who has also won success through his dialectic impersonations. Mr. Lewis has made many records for the Columbia library which have won great popularity with music lovers, and he was accorded an enthusiastic reception.

B. F. Morrison, of the Geo. B. Clarke Co., Bridgeport, Conn., gave an interesting and practical talk regarding the possibilities of merchandising Columbia products. He called attention to the fact that his company, which handles the Columbia line exclusively, closed more than \$1,000 worth of business on the first day that the department was opened, even though this department had only been briefly advertised.

Frank K. Pennington, assistant general sales manager of the Columbia Co., closed the meeting with one of his usual straight-from-the-

shoulder talks that was heartily applauded by the dealers. Mr. Pennington stated that the four essentials of success are product, opportunity, capital and organization, and under each of these heads pointed out how the Columbia Co. is equipped to serve the interests of its dealers. He told the dealers that every man in the Columbia organization was imbued with the spirit of "peptimism" and his definition of this word impressed the dealers with the fact that optimism plus "pep" is the nucleus of the Columbia sales organization of the present day.

NEW REPRESENTATIVE FOR LONG CO.

W. S. Eitler, formerly a manager for C. J. Heppe & Son, Philadelphia, Pa., has been appointed representative of the Geo. A. Long Cabinet Co., Hanover, Pa., for New York City, Brooklyn, the State of New Jersey, Philadelphia, Baltimore and Washington. He assumed his duties the first of the month, and is making arrangements whereby talking machine dealers will receive more efficient service and hearty co-operation.

Mr. Eitler is well known in talking machine circles, and is thoroughly conversant with the most important questions of the industry.

The Geo. A. Long Cabinet Co. have just completed a new executive building; have also installed a new and modern engine and other machinery to take care of the increased demand for their cabinets. Long cabinets are known throughout the trade for their high-class finish thoroughly in harmony with the machine.

Mr. Eitler will visit the dealers throughout the East and a series of valuable dealer's helps are in preparation.

WANTS RESTRAINING ORDER

The Sonora Phonograph Sales Co. has filed suit in the United States District Court against the Stefanograph Co., New York, asking for an injunction restraining this company from using the name "Lunora" on their phonographs. Papers in this suit were submitted on Thursday, July 11, and a decision is soon expected.

TEST offered to dealers to prove the superiority of Wall-Kane Steel Needles

Take two standard disc records of the same selection, play one ten times with the same WALL-KANE loud needle; play the other record, the same selection, ten times, but with ten, new, full tone steel needles.

You will find that the record played ten times with the same WALL-KANE needle will sound clearer, will have less surface noise, and that under the magnifying glass the grooves of the record played ten times with the ten steel needles will seem to be more disturbed.



Beware of Imitations

Package of 50 WALL-KANE needles, greater value than 500 ordinary steel needles. This handsome metal enameled display stand holds 60 packages, 2 dozen extra loud, 1 dozen medium and 2 dozen loud.

Jobbing territories open

**Progressive Phonographic Supply Co.
145 West 45th Street, New York**

ISSUE ATTRACTIVE CATALOG

The Operaphone Co., Long Island City, N. Y., manufacturer of Operaphone records, has just issued an attractive catalog featuring a complete list of these records. This catalog is



Front Cover of New Operaphone Catalog being distributed to the trade, and has won considerable commendation from the dealers because of its artistic design and distinctive arrangement.

WORLD'S CLASSIFIED ADVERTISING

Any member of the trade may forward to this office a "Situation" advertisement intended for this Department to occupy a space of four lines, agate measure, and it will be inserted free. Replies will also be forwarded without cost. Additional space will be at the rate of 25c. per line. If bold faced type is desired the cost of same will be 25c. per line.

WANTED—We want a high-class salesman to represent us in every State in the Union. Only salesman with best reference considered. This is strictly a commission proposition, but the right man can easily make \$150 to \$200 a month. We prefer men who are at present employed selling talking machines or accessories to handle our line in conjunction with their present line. We will send you full particulars, so write at once. Address R. H. Zinke, Record Needle & Mfg. Co., 407 Manhattan Building, Milwaukee, Wis.

RECORD EXPERT with twenty years' experience wants position as recorder, lateral or vertical. Would like to become associated with concern desiring to manufacture records. Address "Box 534," care The Talking Machine World, 373 Fourth Ave., New York.

A THRIVING phonograph shop on central Broadway having lost its manager, the owners find it necessary to secure an experienced manager, or else to dispose of the business. In the first case, an investment will be required as a guarantee of sincerity. From either standpoint this is an excellent proposition, inviting careful investigation. Address "Box 535," care The Talking Machine World, 373 Fourth Ave., New York.

SALESMEN WANTED—If you cover the phonograph trade in any section of the United States and are interested in a live proposition, either as a side line or as your main line, we have an interesting offer. In answering state territory now covered. Address "Box 522," care The Talking Machine World, 373 Fourth Ave., New York.

POSITION WANTED—By wholesale phonograph and piano salesman. Open for position to travel east of Chicago. Held last position 2½ years. Phonograph position preferred. Best of references. Address "Box 536," care The Talking Machine World, 373 Fourth Ave., New York.

POSITION WANTED—Salesman or tuner. Highest references. Capable branch house management or piano, talking machine or musical instrument department. Age 42. Salary and commission. Address "Box 537," care The Talking Machine World, 373 Fourth Avenue, New York.

SITUATION WANTED—By an experienced talking machine man, experience of ten years, Europe and United States. Has been doing work for some large manufacturing concern—live salesman; mechanic. Address Universal Talking Machine Co., 5021 Baltimore Ave., Philadelphia, Pa.

SITUATION WANTED—Salesman, live wire, special experience in foreign records. Knows the business from A to Z. Address: Universal Talking Machine Co., 5021 Baltimore Ave., Philadelphia, Pa.

OCCUPY NEW COLUMBIA QUARTERS

New Wholesale Department of Columbia Co. in Cincinnati Well Equipped to Meet Growing Demands of Trade in This Territory

CINCINNATI, O., July 10.—The Columbia Graphophone Co. is now located in a splendidly-equipped, six-story building at 427-429 West Fourth avenue. This new location is for the wholesale business alone. The business of the Cincinnati branch has increased to such an extent larger quarters were made imperative. The first floor is used for checking in and checking out stock as it is received from the factory, and as it is reshipped to customers. The re-

SALESMAN, experienced, wants position with phonograph house, who knows the music, piano, furniture and department store trade in the entire South and Middle West; fine reference. Address "Box G. R.," care The Talking Machine World, 373 Fourth Ave., New York.

POSITION WANTED—Talking machine salesman or manager, nine years' experience, inside position. New York or Brooklyn preferred. Can furnish best references. Address "Box 526," care The Talking Machine World, 373 Fourth Ave., New York.

POSITION WANTED—Manager of phonograph department open for place. Now employed. Can bring two good salesmen with him. Address "Box 527," care The Talking Machine World, 373 Fourth Ave., New York.

POSITION WANTED—Expert in hill and dale and lateral recording. Have sample of work that shows superior quality, also knowledge of latest methods of plating and familiar with every detail of record making. Address "Box 528," care The Talking Machine World, 373 Fourth Ave., New York.

POSITION WANTED—Sales or advertising manager with Chicago talking machine manufacturer or local representative for outside concern. Experienced. References. Address "J. N. 6," care The Talking Machine World, 209 South State St., Chicago, Ill.

POSITION WANTED—An exceptionally good talking machine repairman seeks new position. Will go anywhere. Address "Box 529," care The Talking Machine World, 373 Fourth Ave., New York.

SALESMEN wanted who are desirous of making big money selling standard records. Address "J. N. 8," care The Talking Machine World, 209 South State St., Chicago, Ill.

POSITION WANTED—Mechanic with fifteen years' experience constructing and repairing phonographs of all makes. With the largest houses in this country; desires to make a change. Capable executive, thoroughly efficient with modern methods. Can furnish best of references. Will go anywhere. Address "Mechanic," care The Talking Machine World, 373 Fourth Ave., New York.

WANTED—Salesmen, sideline to dealers, filing cabinets for phonograph records, patented, advertised, no samples, sell from photographs; liberal commission. Automatic Container Co., 506 Republic Bldg., Chicago, Ill.

POSITION WANTED—Young man, married, would like to get position anywhere in talking machine line where there is a chance for advancement. City or country. Can be used as all-around man, as I can be a shipping clerk, salesman, repair man, assembler, delivery man; willing to work, not afraid of hard work or long hours. Address "Box 520," care The Talking Machine World, 373 Fourth Ave., New York.

POSITION WANTED—Experienced cabinet factory manager and designer wishes to make a change. Thoroughly familiar with up-to-date methods. Forty years old. Highest reference. Now employed. Address "Box 521," care The Talking Machine World, 373 Fourth Ave., New York.

POSITION WANTED—Mechanic with 15 years' experience constructing and repairing phonographs of all makes, part of years with Victrola line, with one of the largest music houses in this country desires to make a change. Capable executive, thoroughly efficient with modern methods. Can furnish the very best of references. Address "Box 514," care The Talking Machine World, 373 Fourth Ave., New York.

WANTED—Position as salesman or department manager by A-1 Victor man, 26, married. At present in charge of talking machine department of large Western music house. Six years' experience in Victrola business, doing buying, newspaper advertising, window trimming. Can furnish the references you want. Prefer town west of Chicago of not less than 25,000. Address "W. N.," care The Talking Machine World, 373 Fourth Ave., New York.

POSITION WANTED—Thoroughly experienced Phonograph and Record salesman for either road or managing establishment, can vouch for seventy-five thousand dollars gross business per annum, now with leading company, highest grade credentials. Address G. H. Coryell, Saratoga Hotel, Chicago, Ill.

pair room is also on the first floor. The entire second floor is given over to offices and display room for Grafonolas and promotion ideas. The third floor is used for the record department, where they have well-equipped and properly-arranged bins for the storing and handling of three hundred and fifty thousand records. The fourth, fifth and sixth floors are used for the storage of Grafonolas. The building is equipped with electric light, elevator and complete modern fixtures. Manager Dawson seems to be quite happy in his new offices.

Many dealers from over the Cincinnati territory have been visitors to the local Columbia headquarters recently. Without exception they look forward to an unusual trade this fall and winter. They are placing heavy orders for goods in the hope that should transportation shut them off later they will be ready for it.

MAIN SPRINGS AND PHONOGRAPH PARTS

MAIN SPRINGS	
For Edison Motors, size 1½", each	\$1.75
For Columbia Motors, size 1"x0.28x11", each	0.60
" " " size 7/8"x0.23x10", each	0.38
" " " size ¾"x0.22x8½", each	0.24
GOVERNOR SPRINGS	
For Columbia Motors, bent, per 100	1.50
For Victor Motors, per 100	1.50
For Heineman, Markell, etc., per 100	0.60
THUMB SCREWS FOR STYLUS BARS	
For Victor Soundboxes, per 100	1.50
For Columbia Soundboxes, per 100	1.50
MICA DIAPHRAGMS	
For Victor Soundboxes, each	0.15
For Columbia Soundboxes, each	0.25
For all standard Soundboxes, each	0.22
NEEDLE CUPS	
Needle Cups, nickel plated, per 100	2.00
Needle Cups, per 1000	17.50
Covers to nickel cups for used needles, per 100	1.25
Covers, per 1000	10.00
Green Felt for 10" turn-tables, each	0.10
Green Felt for 12" turn-tables, each	0.15

FAVORITE PHONOGRAPH ACCESSORY CO.
1491 DeKalb Avenue Brooklyn, N. Y.

ATTENTION DEALERS
50 Double Spring latest style mahogany machines with cover, \$10; 100 Horn disc machines, \$1.75; new reversible tone arms, 50c up. Bargains in envelopes, albums, reproducers, etc. (References the Chatham Bank), The Woolworth (Est. 1886), 1065 Second Ave. (56th St.), New York.

FOR SALE
A good-paying Talking Machine business carrying Victor and Edison, in a city of 6,000 population in New Jersey. Owing to other interests, owner will sell at inventory, which totals about \$4,000.00. Address "Box 538," care The Talking Machine World, 373 Fourth Ave., New York.

Record Racks for Sale
500-foot wood vertical style. We installed horizontal style in our new wholesale store. Will sell old equipment at \$2.50 to \$6 per lineal foot, most sections 8 feet long. When painted best sections are good enough for highest class retail department. Cost to produce to-day in excess of \$12 per foot.
NEAL, CLARK & NEAL CO.,
778 Washington St., Buffalo, N. Y.

POSITION WANTED—Talking machine salesman, five years' experience. Inside position large city preferred. Familiar with all well known machines. References. Address "A. P. 2," Talking Machine World, 209 So. State St., Chicago, Ill.

WANTED—Thoroughly experienced, aggressive Edison, Victor and Columbia manager is open to manage department. Any location. Success guaranteed. Address "J. L. 8," care The Talking Machine World, 209 South State St., Chicago, Ill.

G. H. McHugh, who was for four years connected with the Church-Beinkamp Co. and for two years in charge of their Columbia department, is now connected with the Columbia Graphophone Co. He will be in charge of promotion work and will very soon make a trip visiting Columbia dealers in the Cincinnati district. His past experience has well fitted him for his work.
Business at the Columbia retail store has shown a remarkable increase in the past two or three weeks. The retail department and the Dictaphone department remained at the old location, 117 West Fourth street, while the wholesale department moved to new quarters. The outlook for the fall trade is excellent, provided sufficient stock can be procured.

SCHUBERT PHONOGRAPH RECORDS

The greatest series of 75c. records ever made.

10-INCH DOUBLE SIDED ALL STARS ALL SELLERS

New list by 15th monthly. Dealers, write for list and prices

BELL TALKING MACHINE COMPANY
44 WEST 37th STREET, NEW YORK

SHELTON ELECTRIC PHONOGRAPH MOTOR

We have increased our factory facilities to handle the demand for the Shelton Electric Motor, and are now ready to make prompt deliveries.

Write for our Special Agency Proposition

SHELTON ELECTRIC CO.
30 East 42nd Street, NEW YORK

Record Delivery Envelopes
Safe - Swift - Secure



The heavy paper means protection; the button and cord mean speed — you can wait on more customers.

Bring out YOUR OWN NAME. Every time an envelope leaves your store, let the advertisement on it take your name to the homes and bring new trade. The advertising more than pays for the envelope. Write for samples and prices.

Lewis C. Frank, 694 Book Bldg., Detroit

FROM OUR EUROPEAN HEADQUARTERS

2 GRESHAM BUILDING, BASINGHALL STREET E. C., LONDON, W. LIONEL STURDY, MANAGER.

Proposed Luxury Tax Legislation a Much Discussed Topic—The New Association of Gramophone and Musical Instrument Traders—Sympathy for Columbia Co. on Destruction of Factory by Fire—Some Interesting Record Lists—Swiss Motors for America—Music Trade Men to Meet in Convention—Information Regarding Goods Furnished to Military and Naval Forces—Other News of Interest

LONDON, ENGLAND, E. C., June 25.—The main subject of interest in gramophone trade circles during the last few weeks is that relating to the proposed luxury tax legislation. It is now pretty generally agreed that our industry will probably be included if the tax revenue therefrom is likely to be justified, cost and trouble of collection considered. The Government Committee, which has been empowered to present a report on articles that may reasonably be defined as pure luxuries, is said to be making rapid progress in the examination of data and personnel. Anyway, it is not thought likely that this impost can come into effect for some months yet, as a separate bill would have to pass the House firstly. This may read consolatory, though it is quite within the bounds of possibility that some method (difficult though it be) may be devised to render the tax partly retrospective from a given date. It is said the Government has accepted a suggestion from Sir Charles Henry providing that the luxury tax shall not be levied on articles purchased for immediate export and that a countervailing duty should be imposed on imported articles similar in character to those which are subject in this country to the tax. A most important clause, as all will agree.

A London contemporary figures on the basis of 20 per cent. as the average amount collectable under the luxury tax proposals, and reckons the contribution of the gramophone trade at this rate as somewhere in the neighborhood of £100,000. In reality, and assuming that the tax is imposed on gramophone and record sales, it is likely to be slightly less than this estimate. The actual amount proposed is one-sixth of the selling price, to be collected from the seller by means of stamps, presumably somewhat on the lines of patent medicine duty stamps. Beginning at two-pence in the shilling (articles of less than one shilling in value are exempt) the luxury duty scale of taxation will rise proportionately up to 10/— for every three pounds.

It cannot be too clearly made known that, despite all the speculation which is rife, the articles which may be liable to the luxury tax have not yet been officially defined. The value of any article for the purpose of taxation will be the price it might be expected to realize if sold in the United Kingdom to a person other than a dealer. Two or more articles of the same kind imported in one package or case are for the purpose of valuation to be reckoned as one. It is certain that the Finance bill will embody a number of exemptions, as in the case of an article imported by a dealer for sale(?), or sent out for repair and returned to the sender, or imported by someone staying in the country for not more than a month and re-exported by the same person, or purchased before the appointed date.

So many considerations enter into a matter of this kind that it were idle to speculate beyond a reasonable limit as to the effect of such a tax upon the gramophone industry. If it is

applied to our trade, it is more than probable that manufacturers will allow the dealer a rebate for the tax and increase the retail price of their records, taking into consideration the persistently meteoric cost of all materials.

The New Association of Gramophone Traders

The need for a close co-ordination of effort among musical instrument manufacturers becomes more and more apparent in view of the economic changes and developments that will certainly eventuate as a result of the general upheaval of traditional national policies throughout the world. As things are measured these days, one minor though not unimportant outcome of the war has been to mould the mentality of man along channels of thought more susceptible to liberal ideas, and to the exclusion of insular prejudice. There prevails a broader outlook—a wider appreciation of those things which only a liberal conception can possibly bring to fruition. Hence, the general recognition of pre-war commercial weaknesses, which allowed us to foster a career of petty jealousy and competitive rivalry among ourselves, to the great advantage of our present enemies. Never too late to mend, it is good to observe the gradual but sure awakening in the trade to the urgent importance of unity in thought and action. To that end the Association of Gramophone and Musical Instrument Manufacturers and Wholesale Dealers (what a terrible title it is, to be sure) has been established. Its sole aim is the interests of our industry; the development of the trade and its protection—present and post-war.

Providing—and I am glad to learn it is so—the association throws open its membership to
(Continued on page 100)



"His Master's Voice"

Copyright

'His Master's Voice'

—the trade-mark that is recognized throughout the world as the

HALL-MARK OF QUALITY

Branches

DENMARK: Skandinavisk Grammophon-Akti-
eselskab, Frihavnen, Copenhagen.

FRANCE: Cie. Française du Gramophone, 115
Boulevard Richard Lenoir, Place de la Répub-
lique, Paris.

SPAIN: Compañia del Gramofono, 56-58 Balmes,
Barcelona.

SWEDEN: Skandinaviska Grammophon-Akte-
bolaget, Drottning Gata No. 47, Stockholm.

RUSSIA: The Gramophone Co., Ltd., 45, Nevsky
Prospect, Petrograd (Petersburg); No. 1
Solyanka, Solyanol Dvor, Moscow; 9, Goloviusky
Prospect, Tiflis; Nowy-Swiat 30, Warsaw; 33,
Alexandrowskaya Ulitsa, Riga; 11 Michallovskaya
Ulitsa, Baku.

INDIA: The Gramophone Co., Ltd., 139, Bal-
lughatta Road, Calcutta; 7, Bell Lane, Fort,
Bombay.

Agencies

AUSTRALIA: S. Hoffnung & Co., Ltd., Sole
Concessionaries of The Gramophone Company,
Limited, 163, Pitt Street, Sydney.

NEW ZEALAND: Gramophoulum, Ltd., 118-120
Victoria Street, Wellington.

SOUTH AFRICA: Darter & Sons, Post Box 174,
Capetown; Mackay Bros., Post Box 251, Jobaunes-
burg; Mackay Bros. & McMahou, Post Box 419,
Durban; Ivan H. Haarburger, Post Box 105,
Bloemfontein; Franz Moeller, Post Box 108, East
London; B. J. Ewins & Co., Post Box 86, Queens-
town; Handel House, Kimberley; Laurence &
Cope, Post Box 132, Buluwayo; The Argus Co.,
Salsbury.

EAST AFRICA: Bayley & Co., Lourenzo
Marques.

HOLLAND: American Import Co., 22a, Amsterd
Veerkade, The Hague.

ITALY: A. Bossi & Co., Via Orefici 2, Milan.

**EGYPT (Also for the Soudan, Greece and the
Ottoman Empire):** K. Fr. Vogel, Post Box 414,
Alexandria.

Great Britain :

The Gramophone Company, Ltd.

HAYES - MIDDLESEX - ENGLAND

This intensely human pic-
ture stands for all that is
best in music

—it is the "His Master's Voice"
trade-mark, and it brings to you,
no matter where you are, the
very best music of every kind,
sung and played by the world's
greatest artists—the greatest
singers, pianists, violinists, or-
chestras and bands—all enshrined
in the unequalled "His
Master's Voice"
records

FROM OUR LONDON HEADQUARTERS—(Continued from page 99)

all firms, large and small, within the definition of its title, without unreasonable restrictions, this trade newspaper is out to wholeheartedly support such an excellent cause. These columns have always been open for the ventilation of important interests affecting the British musical instrument industry, and if I take a personal interest in the fortunes of the new association it is not a little due to the fact that I have consistently advocated for years past the formation of a central body along the lines of the present effort. It is, therefore, a great pleasure to learn, in conversation with one of the governing members of the association, of the intention to adopt a liberal open-door policy and not to exclude membership from any firm, however small or whatever its trading methods are—always providing those methods are straightforward—that may be rightly entitled to subscribe.

Good progress is being made, and membership is increasing to a gratifying extent. A general recognition of the important value of the aims and objects of the association will the more quickly result from publicity in the trade press. All interested must become actual students of the principle involved; thus to carry conviction and instil a rigidly determined policy, developed and co-ordinated along lines that will make for trust in one another, an honest faith to act in all circumstances open and above board, as laid down and thought desirable by the committee for the common good. If, as I believe, members will adopt the practice of taking large views, consistent with the legitimate policy of their business, in contradistinction to purely individualistic opinion, the betterment of the trade as a whole is assured, and its interests preserved, to the exclusion of foreign monopoly. The period of reconstruction is now; not to-morrow. Let us remember that, and support the new association unselfishly and liberally. There is much to be done; let us do it!

An Opening for Gramophone "Doctors"

In drawing attention to the gramophone mechanism casualties at military hospitals, rest camps, recreation huts, etc., a writer in The Daily Express says: "If there are any men or women with some knowledge of the mechanism of the gramophone, and a little spare time, they might well take up the job of repairing hospital casualties among gramophones. I know of a number lying useless in various hospitals which only need a few minor repairs by some one with the requisite knowledge and implements.

Wanted: A Short Descriptive Title

"The Association of Gramophone and Musical Instrument Manufacturers and Wholesale Dealers" is generally conceded to be unduly lengthy and cumbrous in expression. What is wanted is a concise title that will convey, if possible, not only the object but also the nature of the association. To embrace such a large thought in one short sentence is obviously difficult. Why not then a brief descriptive title for gen-

eral use by which the particular association would be easily recognized, followed by a subtitle? Subdivision certainly seems the best plan in this case, and I suggest the committee of the new association might reasonably give it consideration.

The association is for British subjects only, and its main object is the protection of British trade interests. This suggests as the chief title—"The British Music Trade Protective Association." In that title is embodied the main attributes of the nature, aims and objects of the society.

Dealers and the War

Too much importance cannot be attached to the necessity of furnishing all information asked for from dealers as to goods supplied to H. M. Forces, hospitals, etc. The record manufacturers circulate, through their factors, small forms asking for these details to be furnished each month, the forms being returnable to factors. It is imperative that dealers give the utmost attention to doing this. At any time a situation might arise when this information would be called for and serious issues might hang in the balance as a result. Dealers receiving these forms should complete and sign them regularly each month and return them to their factors. Laxity in this respect may recoil upon the heads of those responsible. We refer to this somewhat strongly, as it is evident that some dealers do not appreciate its significance, and we have heard of several cases where dealers have plaintively and stupidly asked: "Is this really necessary month after month? It is such a nuisance!"

A License to Export From America Necessary

It has been made known here that exporters in the United States who desire to send goods to the United Kingdom on private account must first obtain the approval of the British War Mission.

Disastrous Fire at the Columbia Factory

Regarding the serious fire which broke out at 1 o'clock Sunday morning, May 19, at the great Columbia factory, Bendon Valley Garratt Lane, Wandsworth, about which I cabled The World last month, it appears that the only person on the premises was the night watchman, who had made his rounds some half an hour or so before. He was in his watchman's box when the first intimation of anything wrong was the electric light failing, and a moment later a burst of flame through the door of his box. He had just time to telephone the Fire Brigade and make his escape.

It is described as London's most serious fire this year, and the first brigade call of 1918. Some 160 firemen are said to have been engaged on it. The damage is estimated at £30,000. Every part of the factory is a total wreck except, by a stroke of luck, the vault containing valuable master matrices. This, it is believed, will enable the company to resume operations as soon as arrangements can be made, and, al-

REX GRAMOPHONE CO.

are making a Specialty of

EXPORT

in

Horn, Hornless & Portable Disc Machines**REX GRAMOPHONE CO. 2 Elizabeth Place
Rivington Street, LONDON, E. C. 2**

Cable Address "Lyrecodisc, London"

Enquiries Solicited

though nothing definite can yet be stated, it is hoped that this may not be long delayed.

The trade adopted a loyal and sympathetic attitude, as was to be expected of Britishers. Generous competitors freely offered their assistance as soon as the news was known, while printers placed their whole resources at the company's disposal for reprinting record labels. For the moment, while it is impossible to say when further deliveries of records can be made, it is hoped that the company will shortly be in a position to offer a limited service, and arrangements to carry on are already well in hand. Meanwhile, we feel assured the company may rely upon the loyalty of their dealers. Factors are asked to distribute their stocks of records as evenly as possible, and pending receipt of new issues Columbia dealers will doubtless make every effort to push the sales of their present stocks.

The Gramophone at the Theatres

The almost general use of the gramophone in theatrical plays is not so widely known as one would think. "Not counting the many performances where it plays a part in view of the audience, says Leyden College in "The Voice," "I could mention fourteen productions in the West End of London, where bands 'off stage'—orchestras in the ballroom—caroling of birds—shouts of crowds, etc., are all the work of specially made records. The effects are better obtained, and, of course, there is the economical side in these times. The gramophone is a permanent property at most theatres." It would indeed be a long story to cover the many diversified characters played by this most wonderful of all musical instruments!

This Year's British Music Convention

The eighth annual convention of the British Music Industries is to be held on June 26 and 27 at the Connaught rooms, London. Owing partly to so many members of the trade being on national work, and to other circumstances for which war conditions are responsible, the period of the convention has been reduced from the customary four days to practically one day, although sectional meetings will probably be held on the second day. The program is a fairly wide one considering the limited time available, but is singularly devoid of subjects current to the interest of the trade, as, for instance, the recent legislation in connection with the luxury tax proposals, which will probably directly affect the music trade. Of immediate concern, too, are the questions of labor and the supply of raw material. These pertinent subjects

EDISON BELL**WINNER**
TRADE MARK
GRAMOPHONE RECORDSCABLE
"PHONOKINO,
LONDON"**ARE THE GREATEST VALUE FOR MONEY PRODUCED IN GREAT BRITAIN**

TEN INCH

DOUBLE SIDED

NEEDLE CUT

PLAY ON ALL GRAMOPHONES**Catalogue contains 4000 Titles by the Premier Artistes, Instrumentalists, Orchestras and Bands
of the British Empire**

DEALERS PREPARED TO DO BUSINESS ARE INVITED TO COMMUNICATE WITH

Proprietors and Manufacturers, J. E. HOUGH, Ltd., 62 Glengall Road, London, S. E. 15, England

FROM OUR LONDON HEADQUARTERS—(Continued from page 100)

ought to be down for a full debate before the largest possible meeting of traders. On the principle of free and open discussion much good might be expected from an introduction of these debatable questions, and it is a pity that they have not been included on the program.

H. J. Ryalls is to propose what appears to be the only resolution of real practical value, to the effect that "the meeting petitions the Government to prohibit the import of all German pianos (we suggest the more generic term 'musical instruments' should be adopted—Editor) into the United Kingdom, or failing that to impose a tariff of not less than 50 per cent. on all musical instruments imported into this country from enemy sources."

The Guardsman June-July Program

A finely representative list typical of Guardsman quality is that for June-July issued by the Invicta Record Co., Ltd. An exceptionally wide and choice variety of vocal and instrumental records are itemized, there being no less than sixteen ten-inch double records, and eight twelve-inch. The ten-inch vocals comprise many of the latest hits by reputable artists, and of the instrumental numbers special mention should be made of selections I and II, "Bing Boys on Broadway," magnificently rendered by the Regiment Band of R. M. Scots Guards, which well-known organization is also responsible for other leading plays, as, for instance, "Pamela," and "Bubbly" selections. In addition the Scots Guards Band give some stirring reproductions of military marches. "My Task" and "The Old Times Are Coming Back Again" should prove a favorite record; it is by Miss Bessie Lawrence, a contralto of exceptional merit. Record No. 827 carries two sentimental items as violin solos by W. G. Cooke, with pianoforte accompaniment; while last among the ten-inch series but not least is a contribution by the Band of the Honorable Artillery Co., whose brilliant playing of "Sons of the Brave" and "Forward" marches is distinctly well recorded by the Guardsman people.

The eight twelve-inch double records are of high quality, special attention having been given to both the artistic and manufacturing attributes. Let the titles and artists speak for themselves—"Casse Noisette," "Waltz of the Flowers, Dance of the Sugar Plum Fairy," by the Band of H. M. Scots Guards; "Faust," ballet music, parts 1, 2, 3, 4, 5, 6 and 7 on two double records magnificently rendered by J. H. Squire's Karsino Symphony Orchestra; the "Peu d'Amour" (sung in French), and the "Spanish Serenade"—"Lolita" (sung in Italian), by Signor Angelo Roselli, tenor; "La Traviata, Rigoletto"—"Questa O Quella," both sung in Italian by Signor Roselli; "The Lost Chord" and "The Better Land," by Miss Ethel Toms, contralto; and parts 1, 2, 3 and 4 of the "Fringes of the Fleet" (words—Rudyard Kipling; music—Sir Edward Elgar), sung by Frederick Taylor, baritone, with pianoforte accompaniment.

From the foregoing it will be appreciated that the Guardsman record has reached a very high standard of quality, and I can commend these records to all oversea traders desirous of carrying a first-class British line of gramophone records.

Swiss Motors for America

As may be generally known there are certain restrictions upon the quantity of goods that can be imported by this country. Gramophone firms are for this reason two-thirds short of the required quantity of motor supplies. I learn now that America will benefit by the exportation direct from Switzerland of large supplies of the excellent motors made by Messrs. Mermod Frères. The handling of this line has been entrusted to the Sterns Mfg. Co., 19 City road, London, E. C., who have secured the sole selling rights for the United States. In recent conversation with the writer the head of this concern, D. Sternburg, said: "We anticipate doing a large trade with this splendid line of high-grade motors, of which there are several models—single and double spring, and to this end have already opened up negotiations in the States. A central distributing depot will soon be established in New York, where we can take care of large orders on prompt dispatch. Owing to the number of ships in ballast that return to the States, no great difficulty is anticipated in the transit of large consignments, and we are now quoting accordingly on the strength of early delivery."

Mermod Frères motors are favorably known among the British trade to be highly satisfactory. Fitted with worm and pinion-gear drive, they are silent and true running, precision made and throughout of excellent workmanship. Pending the establishment of the American office, inquiries should be addressed to the Sterns Mfg. Co. as above. An announcement to the American trade appears elsewhere in this issue.

A Record Jump in Value

Owing to the general scarcity of good gramophones, it is not perhaps surprising that values have gone up to an exceptional extent. Jake Graham, one of the largest dealers in Liverpool, cites a case in point. A No. 6 "His Master's Voice" model was advertised for sale recently at a local auction mart, which he had sold three and a half years ago at the usual figure, 8 guineas. It realized the startling price of 26 guineas, with an album of records! As Mr. Graham says: "I came away with my tail between my legs, while 'the good old dog' cocked his head a little higher to know that he is held in such high esteem."

Military Endorse Importance of Music Trade

During the hearing of an appeal by the manager of G. Potter & Co., before the Aldershot Tribunal, a letter dated in September, 1916, was put in from the assistant military secretary, war office, that "The work carried out in supplying and maintaining instruments for army bands is of military importance." It was stated that if the appellant went the business would

Soundboxes

If you are after a genuine offer of soundboxes, you'll do well to communicate with us immediately. We have tens of thousands of perfect soundboxes, fitted with the best quality mica. Confidently recommended for cheaper machines, absolutely reliable and give excellent reproduction. Price to clear \$50 per gross, F. O. B. London.

Orders for less than gross lots not accepted

Wire "Knotaslepe, London".

W. H. Reynolds (1915) Ltd.
45, City Road, London, E. C.

Write for new illustrated Complete Catalogue

have to close, as the principal, Captain Potter, had been "out" since the beginning of the war. Three months' exemption was granted.

"The Decca" on Active Service

Barnett Samuel & Sons, Ltd., this city, have issued two attractive booklets containing several photographs of "the Decca" (the service portable gramophone) in actual use at the front. These splendid pictures depict as nothing else the mine of enjoyment which our war-worn soldiers obtain from a little music. It is good to see them around the Decca, their faces wreathed in smiles of boundless pleasure.

Women in the Record Factories

Apropos the replacement of men by female labor in our record and other factories, it is interesting to learn that 95 per cent. of the work in the "His Master's Voice" record-pressing departments is now performed by the fair sex. Of the men employed all are either over military age or have been rejected as unfit for service. Such a small percentage suggests that Hayes must be a very healthy place, or that the atmosphere of pressing rooms is not so unhealthy to work in as is generally thought. It speaks well for the supervision and arrangements of a modern factory where the first consideration, as practiced by this company, is to insure for the employes healthy surroundings and cleanly conditions.

"His Master's Voice" by Bart Kennedy

Under the above caption, the current issue of "The Voice" contains a most interesting and inspiring article by the well-known descriptive journalist and author, Bart Kennedy. It represents a fine eulogy of the gramophone on active (Continued on page 102)

GUARDSMAN RECORDS

REGISTERED



TRADE MARK

10 inch and 12 inch Lateral Cut

We can ship you immediately, any quantity of Records:

BANDS ORCHESTRAS INSTRUMENTAL SOLOS VOCAL

SELECTION OF AMERICAN AIRS

including, "Marching Through Georgia"—"Dixie"—"Arkansas Traveller"—"Red, White and Blue"—"Star Spangled Banner," etc., etc., Recorded by Full Regimental Band of H. M. SCOTS GUARDS. Get Ready Now for the Big Trade coming and have

THE FINEST RECORDS of THE FINEST TITLES at THE FINEST PRICES

Apply for Lists and Prices to INVICTA RECORD COMPANY, Ltd.

Cables: Duarrab, London

1 New Inn Yard, London, E. C., England



YE "POPULAR" RECORDS

LONDON'S LEADING VALUE!!!

Double-Sided
Superb Needle Cut
"Lateral"

"OUR POINTS"
SET OUT BELOW

Have Attracted Keen Overseas Houses

from SCANDINAVIA to PATAGONIA
AND THE PRINCIPAL
EAST and WEST MARKETS of the WORLD

REMEMBER **You Can Have CLOSE QUOTATIONS**
For 5,000 Lots and up Your Selection or a Sample
1,000, 75% "Bands and Orchestrals."

POINTS

- ➔ Repertoire Apprx 2,000 Titles
- ➔ Superb Selection, Bands and Orchestrals
- ➔ Lightning Shipments under Government Export License
- ➔ Packing by Experts
- ➔ **Rock Quotations "Always"**
- ➔ F. O. B. London
- ➔ We attend to all Insurances "if Requested" to Buyers A/c
- ➔ Our Shipping Services, **this Side FREE**

Address: **SOUND RECORDING CO., Ltd.** CABLES "Grammavox"
EXPORT DEPT., 18-19 Swallow Street London
Piccadilly, London, England QUOTATIONS CABLED FREE

FROM OUR LONDON HEADQUARTERS—(Continued from page 101)

service; its wonderful—almost divine—power of healing and comfort to our soldiers. "This glorious voice that contains the myriad voices! It lives with our soldiers, cheering and inspiring them. It helps them to carry on—to live through dark, strange, fateful, terrible days. It calms them when they are sad. It evokes tender memories. It brings to them pictures and visions of home. This splendid voice!" Truly, a spiritual—a national necessity!

A Good Opportunity for Oversea Buyers

For a number of years past the Sound Recording Co., Ltd., has been cultivating the suffrage of oversea traders for their "Popular" and "Grammox" series of records through the columns of this trade newspaper. An increasingly good export business is the result. It is due to the company's close study of their customers' requirements, and, in part, we might be permitted to say, to the worldwide influential circulation of this journal. Whatever the reason, the fact that this firm's records are so much in demand, is sufficient indication of the good value offered. A typical example is provided by the latest program of "Popular" records. It consists of a remarkable variety of vocal and instrumental titles of current interest. As, for instance—"Bing Boys on Broadway," "Good-bye-ee," "Roses of Picardy," "God Send You Back to Me" and dozens of others too numerous to mention. The Sound Recording Co., whose announcement will be found elsewhere in this section, invite correspondence with large buyers overseas, and for their part promise to submit close quotations, exercise care in packing, and arrange for dispatch as promptly as possible. It is, by the way, interesting to learn that consignments have for the most part found their right destination. So the Hun pirates, you see, do not have it all their own way!

J. E. Hough, Ltd., Study Welfare of Staff

During the course of a recent visit to the great Peckham works of J. E. Hough, Ltd., I was very much impressed by what I saw pertaining to the welfare of the staff, of which, as is quite the thing these days, women and girls were in the majority. The gradual change over from male to female labor creates different conditions and, of course, necessitates perhaps a closer study of the needs and interests of the workers. In this regard, Messrs. Hough have evinced a keen perception by the installation of a well-equipped canteen of decidedly homely aspect, where can be purchased a substantial meal of several courses at an extremely moderate figure.

At the same time a run round the firm's spacious showroom is decidedly interesting. Here was attractively displayed hornless, cabinet and exterior-horn instruments in goodly numbers, fitted and constructed with the best materials obtainable, and priced at reasonable figures.

In the record domain the Winner disc is as popular as ever, the only trouble experienced be-

ing the supplies which, great as is the factory output, cannot outstrip, let alone keep up with the demand. Recent issues comprise the popular "hits" and standard titles, vocal and instrumental. Oversea traders should obtain literature and all particulars of trading from J. E. Hough, Ltd., Glengall road, Peckham, London.

Louis Sterling Back From America

Looking very well after his trip across Mr. Sterling, manager of the Columbia Graphophone Co., Ltd., reached England safely on June 16. The voyage was, as things go these times, uneventful. It is good news to learn that the talking machine business in America maintains progress, and Mr. Sterling tells me that he was very much impressed by the remarkable volume of trade under way, notwithstanding the diversion of much labor and material to war work.

News Items From "His Master's Voice" Co.

Partly in order to give their dealers an opportunity for a closer concentration on the sale of some of the splendid records previously issued, and which the public are apt to overlook unless reminded, no June list has been published by this company. Most dealers have a stock of these choice old titles, and the absence of new records for once will help to considerably relieve the situation.

"Yes, Uncle," the Princess Theatre success, is listed as a special by the "His Master's Voice"

people. The series of records carrying the best musical items from this delightful play have been recorded by the original artistes exclusively on "His Master's Voice." Other recent issues comprise the cream of music from London's leading musical plays, and indeed it might truly be said that what isn't on "His Master's Voice" records is not worth hearing.

The Industrial Reconstruction Council

A press announcement makes known that application has been made to the Board of Trade for a license directing an association about to be formed under the above title to be registered with limited liability without the addition of the word "Limited" to its name.

The objects for which the association is proposed to be established are:

(a) To promote and protect the British home and overseas dominions and foreign trade and commerce and the manufacturers of the United Kingdom.

(b) To assist in the promotion of efforts, whether by the Government or otherwise, to bring together representatives of capital and labor for the advancement of trade.

The other objects of the association are set out in extenso in the memorandum of association, a copy of which may be inspected at the office of Messrs. Kimber, Bull, Howland, Clappe & Co., 6 Old Jewry, E. C., 2, London.

PERMITS LICENSING OF TALKING MACHINES FOR EXPORT

War Trade Board, in Recent Announcement, Intimates That the Sending of Talking Machines and Pianos to European and South American Neutrals Will Be Encouraged

WASHINGTON, D. C., July 3.—There has just been announced by the War Trade Board some important rulings of direct interest to the musical instrument manufacturing trade in this country, concerning the exportation of many of the less essential commodities to European neutral nations, which it is believed will accomplish much in the effort to destroy the commercial relations between Germany and these countries and at the same time have excellent effect upon America's trade balance and on the present unfavorable rate of exchange.

In the official announcement to-day containing the list of articles for which export licenses would hereafter be considered "European Holland" and "Denmark proper" are mentioned. The general program, however, is of a much wider scope. Unofficial advices have been received here that an understanding has been had with Sweden, Norway, Switzerland and Spain, whereby they also are to receive the less essential commodities contained in the list as part of general agreements which have recently been adopted.

In dealing with South American nations also, favorable consideration will be given, it is understood, to applications for license to export these less essential commodities when tonnage is available, and it is shown that the articles

are not demanded by the war program of America and its allies. Ships which bring nitrates and other war necessities from South American nations can carry such cargoes on the home trips.

By the adoption of the policy of more freedom in granting licenses for the export of less essential commodities to the European neutrals and South America, it is felt that a long step will be taken in establishing America as a leading participant in the world's commerce. New trade relations, in the case of South America, will, it is believed, be built up, which Germany will find it difficult to encroach upon after the war.

Exports must go in tonnage controlled by the neutral nations, and which will not in any way conflict with the war program of the Allies, and all trade relations will be absolutely controlled by the laws which have been adopted to prohibit trade which might aid German financial or business interests in European neutral or South American countries.

The special list of commodities for which export licenses will be considered by the War Trade Board includes musical instruments, except when composed entirely or mainly of metals. Pianos, phonographs and phonographic records are specially mentioned as acceptable.

LATEST PATENTS RELATING TO TALKING MACHINES AND RECORDS

WASHINGTON, D. C., July 8.—TALKING MACHINE MECHANISM.—Archie E. Parnall, Chicago, Ill., assignor to Frank W. Williams, same place. Patent No. 1,263,279.

This invention relates to talking machine mechanism.

One of the objects of the invention is to provide an improved connection between the tone arm and amplifier which will be simple in construction and durable, and which will permit movement of the tone arm about both vertical and horizontal axes. Figure 1 is a vertical sec-

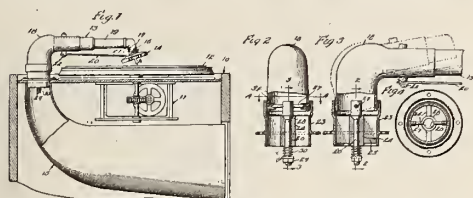

tion through a talking machine; Fig. 2 is a detail sectional view substantially on the line 2-2 of Fig. 3; Fig. 3 is a detail sectional view substantially on the line 3-3 of Fig. 2; and Fig. 4 is a horizontal sectional view on the line 4-4 of Fig. 2.

COIN-FREED GRAMOPHONE.—James W. Knights, Hammersmith, London, Eng. Patent No. 1,262,521.

This invention relates to improvements in coin-freed gramophones of the kind in which a plurality of gramophone records and tone arms are so arranged that any desired record of the plurality of records can be reproduced on the operation of the coin-freed mechanism.

Figure 1 is a diagrammatic side elevation of part of one form of improved coin-freed gramophone. Fig. 2 is an enlarged sectional side elevation of the opposite side; Fig. 3 is a part

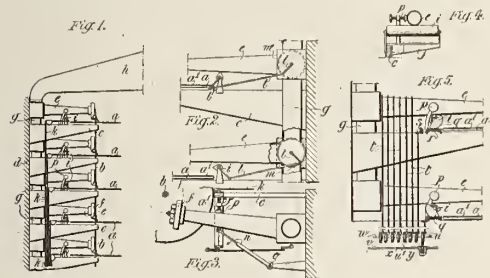

plan; Fig. 4 is a part front sectional elevation; and Fig. 5 is a front elevation of a modification.

ATTACHMENT FOR PHONOGRAPHS.—Earl W. Carlos, Richmond, Ind. Patent No. 1,261,904.

The object of the present invention, briefly stated, is to provide an attachment for phonographs or the like whereby the stylus or reproducer point or needle may be operated to lift it from the record, or to place it gradually in operative position in connection therewith without contact of one's hand with the machine proper and to place such means in the most handy and available position for the accommodation of the operator.

In the management of disk phonographs it is necessary to raise and lower the reproducer and the reproducer-point or needle by simply grasping the goose-neck and turning it up and down, but this invention contemplates means connected to said parts whereby the goose-neck may be turned as above stated but without direct contact of one's hand therewith, thereby dispensing with soiling the polished metal parts, preventing the hand of the operator from being in the way and from causing a shadow upon the needle or reproducer-point when one is making adjustments, to permit the required movements to be made more naturally, and to make the operations more easy for the operator.

Figure 1 is a perspective view of the upper portion of the mechanism of a phonograph or talking machine, showing the invention in oper-

ative position in connection therewith. Fig. 2 is a plan view of the reproducing mechanism, of the goose-neck, a portion of the taper tone arm, and showing an edge view of the attachment. Fig. 3 is a central longitudinal section of a portion of the tone arm box, or cylinder, and

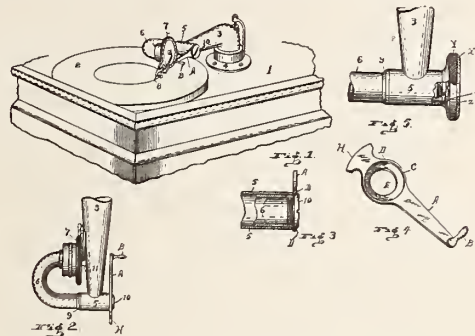

the inner end portion of the longer portion of the goose-neck, and showing the method of attaching the device in operative position. Fig. 4 is a perspective view of the attachment alone. And Fig. 5 shows a plan view of a modified form of the attachment in operative position.

TALKING MACHINE.—Martin Nystrom, Chicago, Ill., assignor to Charles E. Osborne, same place. Patent No. 1,262,592.

This invention relates to talking machines in which a diaphragm is caused to vibrate by the tracking of a needle or point upon a record, and the objects of the improvements are, first, to reproduce the recorded vibrations accurately and correctly; second, to provide a plurality of tracker devices in connection with the diaphragm to enable the use of different records; third, to enable using different kinds of records without in any way making a change in the machine; fourth, to make a simple, cheap and efficient device as well as other features.

There are two known talking machine records on the market. One has the indentations representing the sound record arranged laterally or zig-zag from side to side with relation to the line of travel of the needle, and the other has such indentations arranged up and down or longitudinally with relation to the longitudinal axis of the tracker point; therefore it is necessary to have one kind or style of machine to play or use the one kind of record and to have another kind or style of machine to play or use the other kind of record. By the use of this invention either kind of record can be played or used on the one machine without any foreign or disturbing noises being perceptible.

This invention comprises two tracker devices, one to be used on a record having the laterally arranged indentations and one to be used on a record having the shallow and deep indentations, both of said devices being properly connected to the diaphragm of the machine to vibrate the same when tracking over a record. Of course the one device has the tracker needle in proper position to vibrate the diaphragm when tracking over a record having the later-

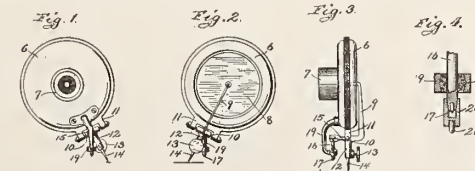

ally or zig-zag arranged indentations and the other device a point in proper position to vibrate the diaphragm when tracking over a record having the shallow and deep indentations.

Figure 1 is a view of one side of a sound box having tracker devices embodying the invention connected thereto; Fig. 2 is a view of the opposite side of the same sound box; Fig. 3 is an edge view of the same showing the construction of the two tracker devices, and Fig. 4 is a

detail sectional view showing the guide for the tracker point rod and also means for attaching a different point to the rod.

SOUND CONVEYER FOR TALKING MACHINES.—Albert A. Huseby, Chicago, Ill. Patent No. 1,261,541.

This invention relates to improvements in sound conveyers for talking machines, and the chief purpose or object of the invention is to provide a sound conveyer that shall be capable not only of playing both laterally and vertically cut records, but of playing each of the said types in the most scientifically correct manner to secure the purest and most perfect reproduction of the record by the machine.

In Letters Patent No. 1,198,636, granted September 19, 1916, there was disclosed a sound conveyer comprising a lower, generally upright portion having a downwardly and forwardly curved form, and an upper, generally horizontal tone arm portion rigidly mounted on and secured to said lower portion, the entire structure being supported, with capacity for lateral swinging movement, on a single horizontal pivot the axis of which is coincident with the center of the vertical delivery mouth of the lower portion of the conveyer. It has been found that a sound conveyer of this construction is excellently adapted to the playing of disk records of the laterally undulating groove type by reason of the fact that the point of the needle travels in a straight line radially of the record disk while the needle itself is always in a vertical plane that is substantially tangential to the groove at the point of engagement of the groove by the needle point. On the other hand it has been found

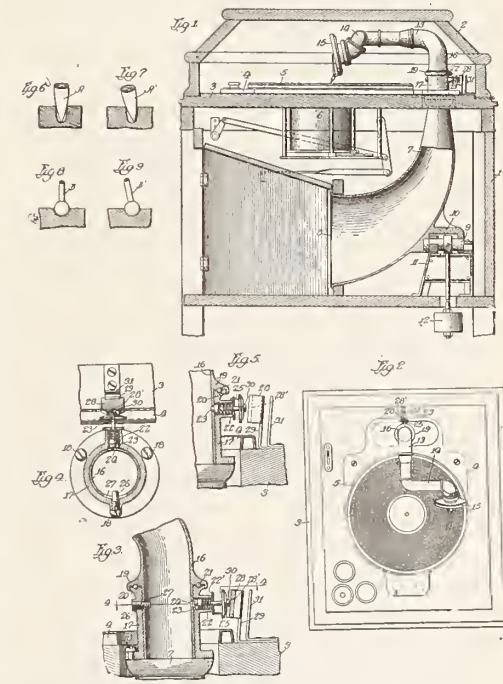

that for the playing of disk records of the vertically undulating or hill and dale type the above described construction does not yield as good results as are obtained by the generally used vertically pivoted tone arm swinging in a horizontal plane wherein the point of the needle travels in an arc of a circle across the face of the record disk. The hill and dale record, of course, imparts a vertical vibration to the whole sound box which is wholly lacking in the other type of record, and this creates a tendency for the point of the needle to jump out of the groove especially when playing records having very steep or abrupt elevations and depressions; and this tendency, as it has been found by numerous experiments, is more pronounced in the case of the construction of prior patent above referred to than in the case of the vertically pivoted tone arm.

The present invention is the result of a long effort and search to obtain, in a talking machine, a sound conveyer construction which when equipped with a convertible sound box, would play each of the two types of record in the most nearly ideal manner and would yield the most nearly perfect results.

(Continued on page 104)

LATEST PATENTS RELATING TO TALKING MACHINES AND RECORDS—(Continued from page 103)

Figure 1 is a vertical section through the upper portion of a talking machine cabinet, with certain of the interior parts appearing in section and others in elevation; Fig. 2 is a top plan view with the lid removed; Fig. 3 is a detail view on an enlarged scale in vertical section through the joint between the upper and lower sections of the sound conveyer; Fig. 4 is a horizontal section on the offset line 4—4 of Fig. 3; Fig. 5 is a fragmentary vertical section similar to Fig. 3, but illustrating the locked position of the two sections of the sound conveyer; Figs. 6 and 7 are detail views in the nature of diagrams designed to illustrate the different relations of the needle and record groove of a laterally cut record where the point of the needle moves in a radial line and where it moves in the arc of a circle over the face of the record; Figs. 8 and 9 are views similar to Figs. 6 and 7 respectively and illustrate the relations of the needle and groove of a vertically cut record where the needle moves radially and where it moves in the arc of a circle over the face of the record.

TALKING MACHINE SOUND BOX AND REPRODUCER.—Patrick B. Delany, South Orange, N. J. Patent No. 1,261,218.

This invention contemplates certain improvements in talking machine sound boxes and reproducers.

As illustrated in the accompanying drawing, Figure 1 is a face view of the sound box complete. Fig. 2 is a perspective of the vibrating arm detached. Fig. 3 is a section on line 3—3, Fig. 1. Fig. 4 differs slightly from the illustration of Fig. 3 in that it shows the threaded engagement between the cruciform vibrating arm

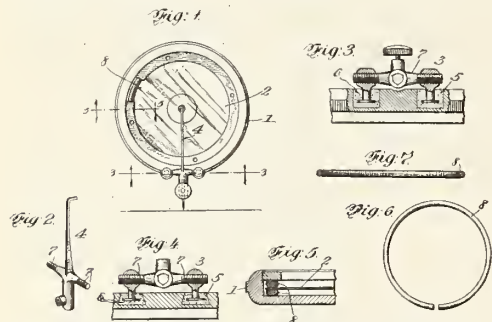

and its supports having right and left threads. Fig. 5 is a section on line 5—5, Fig. 1. Fig. 6 shows one of the gaskets between which the diaphragm is mounted. Fig. 7 is a cross section of Fig. 6.

PHONOGRAPH.—Carl Stein, Steger, Ill., assignor to Steger & Sons Piano Mfg. Co., same place. Patent No. 1,261,174.

The purpose of this invention is to provide an improved construction in a phonograph or sound reproducing instrument, particularly with respect to the amplifying and resonating devices. It consists in the elements and features of construction shown and described, as indicated in the claims.

Figure 1 is a vertical section, axial with respect to the vertically extending member of the sound conduit, of a phonograph embodying the

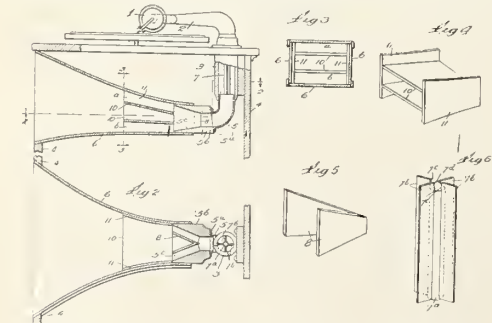

features of this invention, the reproducer and tone arm and the record carrier being shown in side elevation and conventionally—that is, without regard to details of construction. Fig. 2 is a vertical section at the line, 2—2, on Fig. 1. Fig. 3 is a section at the line, 3—3, on Fig. 1. Fig. 4 is a perspective view of a removable

resonating device adapted to be contained in the horn mouth or amplifier. Fig. 5 is a perspective view of an obstructive deflecting device, adapted to be positioned at the smaller end of the amplifier or horn mouth terminal of the conduit. Fig. 6 is a perspective view of a partitioning device employed in the sound conduit at the entrance to the amplifier or resonator.

SPLIT MANDREL.—Lotus G. Larsen, Bridgeport, Conn., assignor to the American Graphophone Co., same place. Patent No. 1,265,793.

This invention relates to talking machines, and more particularly to a support for the sound record tablets thereof. It is customary with machines employing the so-called cylindrical type of record tablet to provide a mandrel having a slightly tapered exterior surface, the bore of the tablet being correspondingly tapered to fit the mandrel with such a grip that it may be rotated thereby. In the course of manufacture slight variations occur in the dimensions of the surface of the mandrel and of the bore of the tablet, with the result that different tablets do not fit different mandrels with the same degree of accuracy, both as respects their relative taper and as respects their mean dimensions. Furthermore, as the mandrel is usually made of metal, its co-efficient of expansion and contraction is different from that of the material of which the tablet is composed. Accordingly, changes of temperature effect different degrees of expansion and contraction of the tablet and mandrel. It is of importance, particularly with machines that employ correction devices, that the tablet shall always be placed in a predetermined position with relation to the mandrel and its related mechanism. Owing to the variations arising in the course of manufacture, as above indicated, and owing to different temperature conditions, a tablet frequently cannot be properly positioned upon a mandrel without danger of breaking it.

It is an object of this invention to provide a mandrel whereby the tablet may be properly gripped for rotation, and whereby it may always be properly positioned, without danger of breakage from temperature changes or from undue pressure in attempting to force the tablet to its proper position.

A further object of this invention is to provide a mandrel which shall resiliently grip the

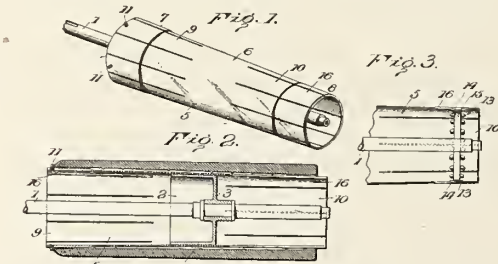

tablet only adjacent its ends, permitting ready application of the tablet upon and withdrawal of the same from the mandrel. A still further object is to provide a mandrel simple in construction, durable and easy of manufacture.

This invention comprises a mandrel provided with a rigid central portion and relatively and independently collapsible resilient end portions. While the resiliency of the end portions may be provided in a variety of ways, the embodiments of the invention selected for illustration comprise the provision of a plurality of tongues running longitudinally of the mandrel and conveniently produced by a series of saw-kerfs extending from each end of the mandrel. To provide for resiliently gripping the tablet only at its ends, the central portion of the mandrel is reduced in exterior diameter.

Referring to the accompanying drawings, Figure 1 is a perspective view of a mandrel embodying the invention. Fig. 2 is a longitudinal central sectional view of the same, showing a record tablet in position; Fig. 3 is a fragment of a mandrel illustrating a modified embodiment.

COVER SUPPORT FOR PHONOGRAPHS.—Martin Bersted, Chicago, Ill., assignor to the Brunswick-

Balke-Collender Co., same place. Patent No. 1,265,874.

This invention relates to a cover support for phonographs and has for its object the provision of means for securely holding the cover in closed or opened position as desired, the cover being readily adjustable by simply grasping and moving it without the necessity of manually disengaging latches or other parts intended to hold the cover in place.

Figure 1 is a side elevation of the device applied to a phonograph, a fragment of the latter

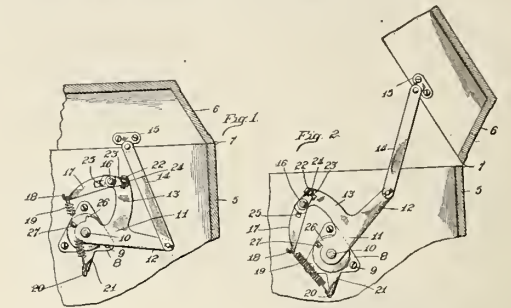

being illustrated in section, with the parts in closed position, and Fig. 2 is a similar view showing the parts in opened position.

ATTACHMENT FOR PHONOGRAPHS.—George W. Van Nortwick, Denver, Colo. Patent No. 1,266,181.

This invention relates to attachments for phonographs and its primary object resides in providing a simple appliance by which the needle-carrying element of the instrument is automatically retained in a raised position after it has been lifted to disengage the needle from the record.

By the use of this invention, accidental dropping of the needle or stylus onto the grooved zone of the record is positively avoided, and the arm bearing the needle may be moved across said zone for the purpose of returning the needle to its original position after it has traversed the zone producing groove, without danger of its coming in contact with the grooved portion of the record and without scratching or otherwise marring the same.

Figure 1 is a fragmentary elevation of a phonograph to which attachment is applied. Fig.

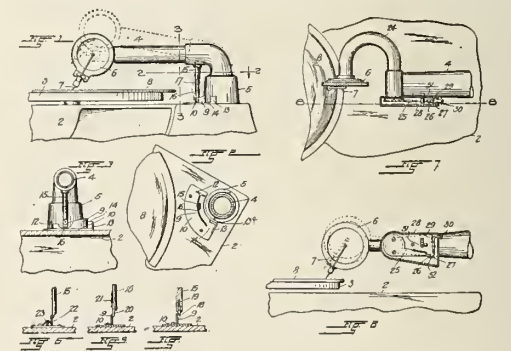

2, a section taken along the line 2—2, Fig. 1. Fig. 3, a horizontal section along the line 3—3, Fig. 1. Figs. 4, 5 and 6 sectional views showing modifications of the arm of the appliance shown in Fig. 1. Fig. 7, a fragmentary plan view of a phonograph showing the invention as applied to a tone arm on which the sound box and needle are carried through the instrumentality of a pivoted goose-neck, and Fig. 8, a section taken along the line 8—8, Fig. 7.

REPAIRS

All Makes of Talking Machines
Repaired Promptly and Efficiently

TALKING MACHINE REPAIR
AND SALES CORPORATION

ANDREW H. DODIN, President
176 Sixth Avenue New York

TELEPHONE, CHELSEA 8437

RECORD BULLETINS FOR AUGUST, 1918

VICTOR TALKING MACHINE CO.

POPULAR SONGS

- 18465 They Were All Out of Step But Jim, Billy Murray 10
We're All Going Calling on the Kaiser, William J. "Sailor" Reilly 10
18474 When I Send You a Picture of Berlin, Arthur Fields and Peerless Quartet 10
18480 We'll Do Our Share, Peerless Quartet 10
Cheer Up, Father; Cheer Up, Mother, Lewis James 10

DANCE RECORDS

- 18472 Skeleton Jangle-Fox-trot, Original Dixieland Jazz Band 10
Tiger Rag-One-step, Original Dixieland Jazz Band 10
18473 Smiles-Fox-trot, Joseph C. Smith's Orchestra 10
Rose Room-Fox-trot, Joseph C. Smith's Orchestra 10
18478 My Dough Boy-One-step, Joseph C. Smith's Orchestra 10

VOCAL AND INSTRUMENTAL RECORDS

- 70121 Granny's Laddy, Harry Lauder 12
18431 By the Waters of Minnetonka, Princess Watahwaso 10
A Sioux Serenade, Princess Watahwaso 10
55093 American Fantasie-Part I, Victor Herbert's Orchestra 12
American Fantasie-Part II, Victor Herbert's Orchestra 12
RED SEAL RECORDS
FRANCES ALDA, Soprano
64782 The Magic of Your Eyes, Arthur Penn 10
SOPHIE BRASLAU, Contralto
74577 Eili, Eili, lama sabachthani (Father, Why Hast Thou Forsaken?), M. Schalit 12
FIRST RECORD BY THE "FLONZALEY QUARTET"
64784 Canzonetta (From "String Quartet in E flat," Op. 12, No. 2), Mendelssohn 10
MABEL GARRISON, Soprano
64783 Khaki Sammy, John Alden Carpenter 10
EVAN WILLIAMS, Tenor
74571 The Song that Reached My Heart, Julian Jordan 12
The following record appears in the August, 1918, Supplement. Do not duplicate order on this number:
18479 Hello Central, Give Me No Man's Land (from N. Y. Winter Garden production, "Sinbad"), Edna Brown 10
My Belgian Rose, Elliott Shaw-Charles Hart 10

COLUMBIA GRAPHOPHONE CO.

- 49338* Annie Laurie, Hulda Lashanska 12
49350* Ave Maria (Violin obbligato by Sascha Jacobsen, Romano Romani at the piano), Nipolito Lazaro 12
49370* Qui La Voce? - Part I, Maria Bartietos
POPULAR HITS OF THE MONTH
A6051* The Man Who Put the Germ in Germany (What is in a name), Nora Bayes 12
Mammy's Chocolate Soldier, Nora Bayes 12
A2562* God Be With Our Boys Tonight, Charles Harrison 10
When You Come Home, Henry Burr 10
A2556* If He Can Fight Like He Can Lovc (Good Night, Germany), Farber Sisters 10
Where Do They Get 'Em and How Do They Get 'Em?, Van and Schenck 10
A2564* You're in Style When You're Wearing a Smile, Arthur Fields 10
I'd Like to See the Kaiser With a Lily in His Hand, Robert Lewis 10
A2567* France, We'll Rebuild Your Towns For You, Peerless Quartet 10
Paul Revere, Vernon Dalhart 10
A2563* He's Got Those Big Blue Eyes Like You, Daddy Mine, Henry Burr 10
I Miss My Daddy's Good-Night Kiss, Henry Burr 10
A2559* Belgian Rose, Campbell and Burr 10
My Daddy's Star, Robert Lewis 10
A2554 The Shannon, the Shamrock, and You, Charles Harrison 10
Mother, My Dear, Charles Harrison 10

DANCE RECORDS

- A2565* How'd You Like to Be My Daddy, from "Sinbad"-Medley Fox-trot. Intro.: (1) Just a Baby's Prayer at Twilight, (2) I Hate to Lose You, Marconi Brothers 10
Why Do They All Take the Night Boat to Albany?, from "Sinbad"-Medley One-step. Intro.: (1) The Devil Has Saved Up All the Coal, (2) I Hate to Lose You, Marconi Brothers 10
A2566* We'll Do Our Share-Medley Fox-trot. Intro.: (1) I Can't Let 'Em Suffer, Earl Fuller's Rector Novelty Orchestra 10
I Want Him Back Again-Medley One-step. Intro.: (1) I Want a Daddy Like You, (2) I Just Step in to Get Out of the Rain, Earl Fuller's Rector Novelty Orchestra 10
A6049* If They Ever Put a Tax on Love-Medley Fox-trot. Intro.: (1) I'm Just an Old Jay From the U. S. A., (2) In the Days of Auld Lang Syne, Prince's Band 12
Just Like Washington Crossed the Delaware-Medley One-step. Intro.: (1) We Stopped Them at the Marne, (2) When We Wind Up the Watch on the Rhine, Prince's Band 12
A6050* Classic Waltz. Intro.: (1) Home to Our Mountains, from "Il Trovatore," (2) Woman is Fickle, from "Rigoletto," (3) My Heart at Thy Sweet Voice, from "Samson and Delilah", Jockers Brothers 12
When You and I Were Young, Maggie-Medley Waltz. Intro.: Coming Thro' the Rye, Jockers Brothers 12
A2549 Sailing, Columbia Stellar Quartet 10
The Girl I Left Behind Me, Columbia Stellar Quartet 10

CORNET CLASSICS

- A2553 Macushla, Herbert L. Clarke 10
Killarney, Herbert L. Clarke 10
MISS FAGAN WHISTLES OLD FAVORITES
A2555 Listen to the Mocking Bird, Sybil Sanderson Fagan 10
Old Folks at Home, Sybil Sanderson Fagan 10
A2551 Up For Sentence, Golden and Heins 10
The Colored Recruit, Golden and Heins 10
JULY MID-MONTH LIST ON SALE JULY 10
A2560* Rock-a-Bye Your Baby With a Dixie Melody, from "Sinbad", Al Jolson 10
Alice, I'm in Wonderland (Since the Day That I First Met You), Sterling Trio 10
T2561* The Daughter of Rosie O'Grady, Robert Lewis 10
Bye and Bye, Campbell and Burr 10
A2557* I Wonder What They're Doing Tonight, Arthur Fields and Peerless Quartet 10
I'm Always Chasing Rainbows, from "Oh, Look," Harry Fox 10

- A2558* Cheer Up, Mother, Hugh Donovan and James Reed 10
When the War is Over I'll Return to You, Peerless Quartet 10
A2552 'A Frangesa-Intro.: Vocal Chorus, Prince's Band 10
French National Defile March, Prince's Band 10
A6046* Toujours ou Jamais (Ever or Never), Prince's Orchestra 12
Danube Waves, Prince's Orchestra 12
A2550* At the Cotton Picker's Ball-Fox-trot, Marimbaphone Band 10
There's a Lump of Sugar Down in Dixie-Medley One-step. Intro.: (1) Cleopatra, (2) 'N Ev'rything from "Sinbad," Marimbaphone Band 10
A6047* Rose Room Fox-trot, Prince's Band 12
Where Those Cotton Blossoms Grow-Medley One-step. Intro.: (1) When You Feel a Little Longing in Your Heart, from "The Love Mill," (2) The Love Mill, Prince's Band 12

*Records marked with an asterisk are all featured in the Dealers' Service August Window Display material.

PATHE FRERES PHONOGRAPH CO.

POPULAR "HITS" OF THE MONTH

- 20393 Your Lips Are No Man's Land But Mine (Empey-McCarron-Morgan), Campbell and Burr 10
Our Country's In It Now (Empey-McCarron-Morgan), Invincible Four (Male Quartet) 10
20388 Won't You Be a Dear, Dear Daddy (Creamer-Layton), The Farber Girls 10
They Were All Out of Step But Jim (Berlin), Constance Farber, Contralto 10
20391 We Stopped Them at the Marne (Lieut. Gitz Rice), Arthur Fields and Invincible Four 10
If He Can Fight Like He Can Love, Good-night Germany! (Meyer), Arthur Fields, Baritone 10
20389 Hello America, Hello (Fairman), Louis Winsch, Baritone 10
From the North, South, East and West (Lauder), William Simmons, Baritone 10
20390 I Miss That Mississippi Miss That Misses Me (Wending), Big City Four 10
My Belgian Rose (Garton), Harry McClaskey, Tenor 10
20392 Those Draftin' Blues (Pinkard), Arthur Collins, Baritone 10
If You're Crazy About the Women, You're Not Crazy At All (Ruby), Joe Remington, Baritone 10
20387 She's Not in Tipperary (Chapin), Invincible Four (Male Quartet) 10
Alice, I'm in Wonderland (Fields-Morse), Sterling Trio 10
25016 There's a Long, Long Trail (Elliott), Percy Hemus and His Buddy Boys 10
Khaki Sammy (Carpenter), Percy Hemus, Baritone 10
29208 Ten Little Bridesmaids (Watson-Lee), Jack Norworth, Baritone, Piano accomp. 12
I Stopped, and I Looked, and I Listened! (Ayer), Jack Norworth, Baritone, Piano accomp. 12

NEW STANDARD BALLADS SUNG IN ENGLISH

- 40125 Because I Love You Dear (Stanton-Hawley), James Stanley, Basso 12
Danny Boy (Weatherley), Marie Van Essen, Contralto 10
52030 An Irish Folk-Song (Foote), Alma Beck, Contralto 12
29202 Last Night (Kjerulf), Alma Beck, Contralto 12
O Canada! (Our Father's Land of Old (Laval-lee), Frank Oldfield, Baritone 12
I Love You, Canada (Manley), Frank Oldfield, Baritone 12

NEW INSTRUMENTAL RECORDS

- 60071 Thais (Massenet) "Meditation," Violin solo, Jacques Thibaud, Piano accomp. 12
Serenade (Schubert), Violin solo, Jacques Thibaud, Piano accomp. 12
20381 Where the River Shannon Flows (Russell), Cornet solo, Boliumir Kryl, Piano accomp. 10
Killarney (Balfe), Cornet solo, Bohumir Krvl, Piano accomp. 10
20382 Here Comes America (Glogau-Piantadosi), Medley One-step. Intro.: "Send Me Away With a Smile", Accordion duet, Boudini Brothers 10
Silver Heels (Moret), "Intermezzo" Banjo and Accordion, Edward Boynton and D. Boudini 10

NEW GEMS BY THE HAWAIIANS

- 20385 Hawaiian Nights (Roberts), Waltzes, Louise and Ferera Hawaiian Orchestra 10
Somewhere in Hawaii (MacMeekin), Louise and Ferera Hawaiian Orchestra 10

NEW PATHE "DE LUXE" DANCE RECORDS

- 29207 Military Waltz (Logan), American Republic Band 12
While the Incense is Burning (Smith), Medley Fox-trot, "Rose Room" Fox-trot, American Republic Band 12
71002 Oh! Look! (Carroll), Medley Fox-trot. Intro.: "Typical Topical Tunes," "A Kiss for Cinderella," "I'm Always Chasing Rainbows," American Republic Band 14
Sweet Little Buttercup (Paley), Medley One-step. Intro.: "Cleopatra" from "Sinbad," American Republic Band 14

SPECIAL LIST OF SEASONABLE SUMMER DANCE RECORDS

- 20317 The Tickle Toe, from "Going Up" (Hirsch), Medley Fox-trot, American Republic Band 10
The Moonlight Waltz (Logan), American Republic Band 10
20321 My Sweetie (Snyder-Louis-Young), Medley Fox-trot, Boudini Brothers, Accordionists 10
A Scotch High Ball (Arr. by Boudini Brothers) (Medley One-step), Boudini Brothers, Accordionists 10
20320 Going Up, from "Going Up," Medley One-step, American Republic Band 10
Midnight Valse (Holland), American Republic Band 10
20319 When You Come Back (Frey), One-step, The Story Book Ball (Montgomery-Perry), Fox-trot, American Republic Band 10
20357 A Baby's Prayer at Twilight (Jerome), One-step, American Republic Band 10
Flower of the Orient (Savino), "Waltz," American Republic Band 10
20356 Oh! Lady! Lady! (Kern), Medley Fox-trot, American Republic Band 10
Pack Up Your Troubles in Your Old Kit Bag, Medley One-step, American Republic Band 10
20328 Stockyard Blues (Pinkard), Fox-trot, Van Eps-Banta Dance Orchestra 10
Popularity (Cohan), One-step, Van Eps-Banta Dance Orchestra 10
20368 Why Do They All Take the Night Boat to Albany? One-step, Hotel Biltmore Dance Orchestra 10
When I Feel Sad and Lonely (Fuller), Fox-trot, Hotel Biltmore Dance Orchestra 10
29200 Toot Toot (Kern), Medley One-step, Hotel Biltmore Dance Orchestra 12

- The Booster (Lake), Fox-trot, Hotel Biltmore Dance Orchestra 12
71001 I'll Think of You, from "The Rainbow Girl" (Hirsch), Medley Fox-trot, Hotel Biltmore Dance Orchestra 14
Songs of the Night (James), "Waltz," Hotel Biltmore Dance Orchestra 14
NEW OPERATIC AND CLASSIC VOCAL RECORDS
Important Issue of Single Face Records, Sung by Lucien Muratore, World Famous Tenor-Chicago Opera Co.
54001 Manon (Massenet), "Ah! fuyez, douce image" (Depart! Fair Vision)-In French, Lucien Muratore, Tenor 12
54002 La Marseillaise (de l'Isle)-In French, Lucien Muratore, Tenor 12
59057 Barbieri di Siviglia (Rossini), "Cavatina," Part 1, in Italian, Tito Schipa, Tenor 12
Barbieri di Siviglia (Rossini), "Cavatina," Part 2, in Italian, Tito Schipa, Tenor 12
25017 Se Sagan Roses (When Bloom the Roses) (Ar-diti), Grace Hoffman, Soprano 10
Staccato Polka (Milder), Grace Hoffman, Soprano, Violin, Flute and Piano accomp. 10

NEW BAND AND ORCHESTRA RECORDS

- 20384 Marche Indienne (Sellenick), American Regimental Band 10
Turkish Patrol (Michaelis), American Regimental Band 10
20386 A Darkey's Dreamland, Part 1 (Bidgood), London Military Band 10
A Darkey's Dreamland, Part 2 (Bidgood), London Military Band 10
20383 The Humming Bird (Sellenick), Pathe Freres Orchestra 10
The Flower-Strewn Pathway (Gourand), Pathe Freres Orchestra 10
29206 Polonaise Militaire (Chopin), Royal Court Orchestra 12
Funeral March of a Marionette (Gounod), Royal Court Orchestra 12
40130 Demoiselle Chic (Fletcher), "Intermezzo," Imperial Symphony Orchestra 12
Handel Wakes (Morrissy), Imperial Symphony Orchestra 12

EDISON BLUE AMBEROL RECORDS

- CONCERT RECORD
28287 Le Nil (Xavier Leroux), Soprano, in French, violin obbligato and orch., Odette Le Fontenay
REGULAR LIST
3520 Alice, Where Art Thou? (J. Asher), Tenor, orch. accomp., Ralph Errolle
3529 Chimes of Normandy (Jack Wells), Contralto, orch. accomp., Helen Clark
3521 Connaugh Man-Medley of Jigs, Accordion, piano accomp., by Joe Linder, John J. Kimmel
3530 Creator's Band March (Gerardo Iasilli), Creator and His Band
3522 He Lifted Me (Chas. H. Gabriel), Mixed voices, orch. accomp., Metropolitan Quartet
3519 I'll Come Back to You When It's All Over (Kerry Mills), Baritone, orch. accomp., Edward Allen and Chorus
3511 I'm Just a Ragged Newsboy, But My Heart's True Blue (Harry D. Kerr), Tenor, orch. accomp., Walter Van Brunt
3528 Just Like Washington Crossed the Delaware, General Pershing Will Cross the Rhine (George W. Meyer), Baritone, orch. accomp., Arthur Fields and Chorus
3526 Kiss Me Again Waltz (Victor Herbert), Waikiki Hawaiian Orchestra (with Louise and Ferera)
3513 Last Long Mile-Too-Too! (Lieut. Emil Breitenfeld), Orch. accomp., Billy Murray and Chorus
3517 Lorraine (My Beautiful Alsace-Lorraine) (Fred Fisher), Tenor, orch. accomp., Vernon Dalhart and Chorus
3514 Oh! Min! (Isham Jones), Comic Song, orch. accomp., Edward Meeker
3516 On the Road to Home Sweet Home (Egbert Van Alstine), Tenor and baritone, orch. accomp., John Young and George W. Reardon (Julius Lenzberg), Jazzarimba Orchestra
3508 Rigoletto Selection, Part 1 (Verdi), American Symphony Orchestra
3509 Rigoletto Selection, Part 2 (Verdi), American Symphony Orchestra
3523 Roamin' in the Gloamin' (Harry Lauder), Orch. accomp., Glen Ellison
3531 That Grand Old Gentleman (Uncle Sam) (Gus Edwards), Baritone, orch. accomp., Arthur Fields and Chorus
3515 There's a Lump of Sugar Down in Dixie (Albert Gumble), Tenor, orch. accomp., Vernon Dalhart
3518 Three Pickaninnies (Kendis-Brockman), Orch. accomp., Collins and Harlan
3524 Three Wonderful Letters from Home (James F. Hanley), Tenor, orch. accomp., George Wilton Ballard
3512 Volunteers March (John Philip Sousa), New York Military Band
3525 We Stopped Them at the Marne (Lieut. Gitz Rice), Male voices, orch. accomp., Premier Quartet
3527 When You Feel a Little Longing in Your Heart-The Love Mill (Alfred Francis), Soprano and tenor, orch. accomp., Gladys Rice and Vernon Dalhart

A FEW SELECT RECORDINGS

- 1747 Baseball Girl, Talking, Ray Cox
2025 Is My Name Written There? (Davis), John Young and Fred Wheeler
2184 La Boheme-Rudolph's Narrative (Puccini), Charles Harrison
2068 When Dreams Come True (Hein and Webb), Thomas Chalmers
1956 When the Bell in the Lighthouse Rings (Solman), Gus Reed

THOS. A. EDISON, INC.

- 83074 Elegie (Jules Massenet), Tenor, in French, Guido Ciccolini
'O Sole Mio (My Sunshine), (Eduardo di Capua), Tenor, in Italian, Guido Ciccolini
82125 Chant Hindou (Hindoo Song), (H. Bemberg), Soprano, in French, Odette Le Fontenay
Le Nil (The Nile), (Xavier Leroux), Soprano, in French, Odette Le Fontenay
82129 O Dry Those Tears! (Teresa del Riego), Contralto, Caroline Lazzari
Oft in the Silly Night, Contralto, Caroline Lazzari
80365 Douglas! Tender and True (Lady John Scott), Contralto, Amy Ellerman
Wonderful Thing (Clare Kummer), Soprano, Betsy Lane Shepherd
80388 Down in Lily Land (F. Wallace Rega), Contralto and Tenor, Marion Evelyn Cox, John Young
Is It Nothing to You? (Edgar-Trevor), Contralto, Betsy Lane Shepherd
80389 Hold Thou My Hand-Sacred (Emelyn R. Mof-fatt), Metropolitan Quartet
Why I Love Him-Sacred (B. D. Ackley), Baritone, Robert E. Clark

(Continued on page 106)

RECORD BULLETINS FOR AUGUST (Continued from page 105)

- 80390 Zampa Overture—Part 1 (F. Hérold), American Symphony Orchestra
Zampa Overture—Part 2 (F. Hérold), American Symphony Orchestra
80391 I'll Take You Home Again, Kathleen (Thomas P. Westendorf), Violin, Violoncello, Flute and Harp...

PARAMOUNT RECORDS

- BROADWAY DANCE HITS
30046 Calicoco (Hugo Frey)—Fox-trot, Yerkes Jazarimba Band
Indianola (Henry)—One-step, Original Saxo-Jazz Band
30053 Cotton Picker's Ball—Fox-trot, Red, White and Blue Marimba Players
Will You Remember from Maytime—Waltz, Red, White and Blue Marimba Players

EMERSON PHONOGRAPH CO.

- Sixty-five Cent Records
Patriotic and Popular Songs of the Hour
940 If He Can Fight Like He Can Love, Good Night Germany (Clarke-Rogers-Meyer)—Patriotic solo, orch. accomp. Eddie Nelson
If You're Crazy About the Women, You're Not Crazy At All (Bryan-Leslie-Ruby)—Baritone Solo, orch. accomp. Henry Lewis

LYRAPHONE CO. OF AMERICA

- STANDARD SONGS
7111 Bell Song (from "Lakme"), Regina Vicarino, Soprano
Bird Song (from "Pearl of Brazil"), Regina Vicarino, Soprano
6143 Loch Lomond (Old Scotch), Ethel Leigh, Soprano
Love's Old Sweet Song (Molloy), Esther May, Contralto

- 6144 When the Roll is Called Up Yonder (Block), St. Cecilia Quartet
Still, Still With Thee (Garrish), St. Cecilia Quartet
POPULAR SONG HITS
5134 A Little Bit of Sunshine (Hanley), John McConnell, Baritone
Mammy's Little Coal Black Rose (Whiting), James Tree and Ethel Leigh

OPERAPHONE CO., INC.

- POPULAR SONGS
5136 'N Everything from "Simbad," Winter Garden (De Sylvia-Kahn-Jolson), Billy Edwards, Baritone, orch. accomp.
K-K-K-Katy (O'Hara), Arthur Courtney, Baritone, orch. accomp.
5137 What Are You Going to Do to Help the Boys? (Kahn-Van Alstyne), Robert Scarth, Baritone, orch. accomp.
Rock-a-Bye Baby With a Dixie Melody (Lewis-Young-Schwartz), James Barton, Baritone, orch. accomp.

- In the Straw," (3) "Chicken Reel" (Characteristic Medley)...Bros. Delenti, Accordion Duct
4131 The Story Book Ball (Montgomery-Perry), Fox-trot...Operaphone Dance Band
Calicoco (Frey), Fox-trot...Operaphone Band
4132 The Tickle Toe (Hirsch), from "Going Up," Intro.: "If You Look in Her Eyes," Medley
Fox-trot...Operaphone Band
The Moonlight Waltz (Logan)...Operaphone Band
4134 A Baby's Prayer at Twilight (Jerome), One-step, Operaphone Band
Oh! Lady, Lady, Intro.: "You Found Me and I Found You," "When the Ship Comes In," Medley
Fox-trot...Operaphone Band
4136 When the Saxophone Is Playing (Hirsch), from "The Grass Widow," Medley
Fox-trot, Van Eps, Banjo, Saxophone and Piano
Love Me at Twilight (Grant), Fox-trot, Operaphone Band
4137 When You Come Back (Frey), One-step, Operaphone Band
Dance With Me (Pollock-Wolf-Hirsch), Intro.; "Just You and Me," from "The Grass Widow," Operaphone Band

EMERSON PHONOGRAPH CO.

- Thirty-five Cent Records
Patriotic and Popular Song Hits
7367 If He Can Fight Like He Can Love, Good Night Germany (Clarke-Rogers-Meyer)—Patriotic solo, orch. accomp. Eddie Nelson
When I Come Back to You We'll Have a Yankee-Doodle Wedding (Tracey-Stern)—Patriotic solo, orch. accomp. Eddie Nelson
7374 Hello Central, Give Me No Man's Land (Lewis-Young-Schwartz)—Tenor solo, orch. accomp. Robert Rice
Love's Old Sweet Song (Bingham-Molloy)—Vocal quartet...Liberty Quartet
7381 We're All Going Calling on the Kaiser (Caddigan-Brennan)—Character patriotic song, orch. accomp. Harry Evans
You Belong to the U. S. A. (Hugo Emerson)—Patriotic solo, orch. accomp. Harry Evans
7380 Cheer Up Father, Cheer Up Mother (Bryan-Daley)—Patriotic solo, orch. accomp. Harry Evans
A Soldier's Rosary (Dempsey-Burke)—Tenor solo, orch. accomp. Frank Woods
7378 Three Wonderful Letters From Home (Goodwin-Macdonald-Hanley)—Tenor solo, orch. accomp. George Gordon
Southern Medleys—Vocal quartet...Liberty Quartet
7379 We Stopped Them at the Marne. It's to With Germany (Lieut. Gitz Rice)—Patriotic solo, orch. accomp. D. (Bud) Bernie
Oui, Oui Marie (Wee, Wee Marie) (Bryan-McCarthy-Fisher)—Character song, orch. accomp. Ben Linn
7375 Chimes of Normandy (Bryan-Wells)—Vocal trio, orch. accomp. Excelsior Trio
Loch Lomond, By You Bonnie Banks (Tenor solo, orch. accomp. George Gordon
7377 I May Stay Away a Little Longer (Brown-A. Von Tilzer)—Baritone solo, orch. accomp. Harry Evans
The Makin's of the U. S. A. (Bryan-H. Von Tilzer)—Patriotic solo, orch. accomp. Eddie Nelson

LATEST DANCE HITS

- 7384 There's a Lump of Sugar Down in Dixie (Gumble-McCabe)—Fox-trot...Emerson Military Band
Land of the Maple (Muir-Laurendeau)—Canadian March and One-step...Emerson Military Band
7376 Everybody's Crazy 'Bout the Dog Gone Blues (Creamer-Layton-Egan)—Medley
Fox-trot, Emerson Military Band
Sorella (L. Gallini)—Spanish March and One-step...Emerson Military Band
7383 Harry Fox Trot (Pollack)...Emerson Military Band
World Democracy (Arthur Bergh)—March and One-step...Emerson Military Band
7382 Kirmanshah (Claypoole-Eastwood)—Oriental One-step—Banjo, Piano and Saxophone, Van Eps Banta Trio
Sing Ling Ting (Cobb)—Chinese One-step—Banjo, Piano and Saxophone, Van Eps Banta Trio

The general sales department of the Columbia Graphophone Co. has announced a cut-out record list that embodies records issued since the last cut-out exchange in September, 1917. The records that are listed as cut-outs will not be included in the next catalogs, and are exchangeable on the basis of one for one.

George W. Hopkins, general sales manager of the Columbia Co., left on June 29 for San Francisco. He made several addresses at the recent annual convention of the Associated Advertising Clubs of the World.

NEEDLES WE MANUFACTURE Diamond needles for Edison Sapphire needles for Edison Sapphire needles for Pathe in stock ready for delivery MERMOD & CO., 505 5th Ave., N. Y.

SOME OF THE LEADING JOBBERS OF TALKING MACHINES IN AMERICA

1856 **WURLITZER** 1916

VICTOR
DISTRIBUTORS
VICTORS EXCLUSIVELY

We make a specialty of getting the order out on time—every time.

The Rudolph Wurlitzer Co.
CINCINNATI AND CHICAGO

Two points of supply; order from the nearer

TEST IT. 

OUR VICTOR

Record Service

has a reputation for efficiency.
Suppose you try it.

E. F. DROOP & SONS CO.
1300 G. STREET, WASHINGTON, D. C.
231 N. HOWARD STREET, BALTIMORE, MD



Chas. L. Marshall & Co.
Wholesale Distributors for Michigan of

THE INSTRUMENT OF QUALITY

Sonora
CLEAR AS A BELL 

also representing Sonora Phonograph Sales Co. of New York in State of Ohio

810 Empire Bldg., Detroit, Mich.



Where Dealers May Secure

COLUMBIA

Product

STARR Phonographs and GENNETT Records

Complete Stock and REAL Service

Crafts-Starr

PHONOGRAPH CO.
Factory Distributors
218-220 NORTH SECOND STREET, RICHMOND, VIRGINIA
Write for Dealers' Proposition

Smith, Kline & French Co.
PHILADELPHIA

Wholesale Distributors for

THE INSTRUMENT OF QUALITY

Sonora
CLEAR AS A BELL 

In PENNSYLVANIA, NEW JERSEY and DELAWARE

Ready, Full Stocks, and Prompt Deliveries from Convenient Shipping Centers all over the United States.

Southern Victor Dealers
Largest Stock VICTROLAS and RECORDS.
Prompt Shipment and Low Freight Rates.

WALTER D. MOSES & CO.
Oldest Music House in Virginia or North Carolina.
RICHMOND, VA.

- Distributors**
- Atlanta, Ga., Columbia Graphophone Co., 63 N. Pryor St.
 - Baltimore, Md., Columbia Graphophone Co., 16 South Howard St.
 - Boston, Columbia Graphophone Co., 137 Federal St.
 - Buffalo, N. Y., Columbia Graphophone Co., 737 Main St.
 - Chicago, Ill., Columbia Graphophone Co., 14 N. Michigan Ave.
 - Cincinnati, O., Columbia Graphophone Co., 117-119 W. Fourth St.
 - Cleveland, O., Columbia Graphophone Co., 1375 Euclid Ave.
 - Dallas, Tex., Columbia Graphophone Co., 1011 Elm St.
 - Denver, Colo., Columbia Stores Co., 1608 Glenarm Place.
 - Detroit, Mich., Columbia Graphophone Co., 401 Woodward Ave.
 - Indianapolis, Ind., Columbia Graphophone Co., 44 N. Pennsylvania St.
 - Kansas City, Mo., Columbia Graphophone Co., 1027 McGee St.
 - Los Angeles, Cal., Columbia Graphophone Co., 745 S. Broadway.
 - Minneapolis, Minn., Columbia Graphophone Co., 412-414 Nicollet Ave.
 - New Haven, Conn., Columbia Graphophone Co., 206 Meadow St.
 - New Orleans, La., Columbia Graphophone Co., 517-525 Canal St.
 - New York City, Columbia Graphophone Co., 55 Warren St.
 - Omaha, Neb., Schmoeller & Mueller Piano Co.
 - Philadelphia, Pa., Columbia Graphophone Co., 210 N. Broad St.
 - Pittsburgh, Columbia Graphophone Co., 632-640 Duquesne Way.
 - Portland, Me., Columbia Graphophone Co., 43 Exchange St.
 - Portland, Ore., Columbia Graphophone Co., 429-431 Washington St.
 - Salt Lake City, Utah, Columbia Stores Co., 221 South West Temple.
 - San Francisco, Cal., Columbia Graphophone Co., 130-150 Sutter St.
 - Seattle, Wash., Columbia Graphophone Co., 911 Western Ave.
 - Spokane, Wash., Columbia Stores Co., 618 Sprague Ave.
 - St. Louis, Mo., Columbia Graphophone Co., 1127 Pine St.
 - Tampa, Fla., Tampa Hardware Co.
- Headquarters for Canada:
Columbia Graphophone Co., 54-56 Wellington St., West, Toronto, Ont.

OLIVER DITSON COMPANY
BOSTON

Largest VICTOR Talking Machine Distributors East of Chicago.
Creators of "The Fastest Victor Service." Let us tell you more about our service.

W. J. DYER & BRO.
NORTHWESTERN DISTRIBUTORS OF THE

VICTOR
Machines, Records and Supplies

 Shipped Promptly to all Points in the Northwest

ROUNTREE-CHERRY
RICHMOND VIRGINIA

Wholesale Distributors for

THE INSTRUMENT OF QUALITY

Sonora
CLEAR AS A BELL 

YOU above all must be satisfied!

IN NORTH AND SOUTH CAROLINA

The Electric Supply & Equipment Co.
Exclusive Wholesale Distributors for Southern New England

THE INSTRUMENT OF QUALITY

Sonora
CLEAR AS A BELL 

Complete stocks carried in Boston and Hartford

Little Bldg. 103 Allyn St.
BOSTON, MASS. HARTFORD, CONN.

Victor Exclusively
EASTERN TALKING MACHINE CO.
177 Tremont Street, Boston
VICTOR DISTRIBUTORS

Sherman, Clay & Co.

San Francisco, Los Angeles, Portland, Seattle, Spokane
PACIFIC COAST DISTRIBUTORS OF VICTOR PRODUCTS

THIS REFERS TO YOU, MR. DEALER

Every talking machine jobber in this country should be represented in this department, no matter what line he handles or where he is located. The cost is slight and the advantage is great. Be sure to have your card in this department of The Talking Machine World each month. It will pay you a big profit on the investment.

The PERRY B. WHITSIT CO.
Distributors of
Victrolas and Victor Records
COLUMBUS, OHIO

Executive Office
COLUMBIA GRAPHOPHONE CO.
Woolworth Building New York

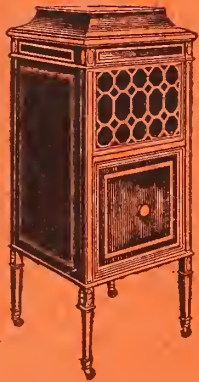

The NEW EDISON

Bears the Stamp of Edison's Genius



JOBBER'S OF THE NEW EDISON, EDISON RE-CREATIONS, THE NEW EDISON DIAMOND AMBEROLA AND BLUE AMBEROL RECORDS

CALIFORNIA
Los Angeles—Edison Phonographs, Ltd.
San Francisco—Edison Phonographs, Ltd.

COLORADO
Denver—Denver Dry Goods Co.

CONNECTICUT
New Haven—Pardee-Ellenberger Co., Inc.

GEORGIA
Atlanta—Phonographs, Inc.

ILLINOIS
Chicago—The Phonograph Co., James I. Lyons. (Amberola only.)

INDIANA
Indianapolis—Kipp Phonograph Co.

IOWA
Des Moines—Harger & Blish.
Sioux City—Harger & Blish.

LOUISIANA
New Orleans—Diamond Music Co., Inc.

MASSACHUSETTS
Boston—Pardee-Ellenberger Co.

MICHIGAN
Detroit—Phonograph Co., of Detroit.

MINNESOTA
Minneapolis—Laurence H. Lucker.

MISSOURI
Kansas City—The Phonograph Co. of Kansas City.
St. Louis—Silverstone Music Co.

MONTANA
Helena—Montana Phonograph Co.

NEBRASKA
Omaha—Shultz Bros.
NEW JERSEY
Paterson—James K. O'Dea (Amberola only.)

NEW YORK
Albany—American Phonograph Co.

New York—The Phonograph Corp. of Manhattan.

Syracuse—Frank E. Bolway & Son, Inc.
W. D. Andrews Co. (Amberola only.)

Buffalo—W. D. & C. N. Andrews Co. (Amberola only.)

OHIO
Cincinnati—The Phonograph Co.
Cleveland—The Phonograph Co.

OREGON
Portland—Edison Phonographs, Ltd.

PENNSYLVANIA
Philadelphia—Girard Phonograph Co.
Pittsburgh—Buehn Phonograph Co.
Williamsport—W. A. Myers.

RHODE ISLAND
Providence—J. A. Foster Co. (Amberola only.)

TEXAS
Dallas—Texas-Oklahoma Phonograph Co.

UTAH
Ogden—Proudfit Sporting Goods Co.

VIRGINIA
Richmond—The C. B. Haynes Co., Inc.

WISCONSIN
Milwaukee—The Phonograph Co. of Milwaukee.

CANADA
Montreal—R. S. Williams & Sons Co., Ltd.

St. John—W. H. Thorne & Co., Ltd.
Toronto—R. S. Williams & Sons Co., Ltd.

Vancouver—Kent Piano Co., Ltd.
Winnipeg—R. S. Williams & Sons Co., Ltd.

Calgary—R. S. Williams & Sons Co., Ltd.

The TALKING MACHINE WORLD

For the
makers &
sellers of
talking
machines

Published Each Month by Edward Lyman Bill, Inc., at 373 Fourth Ave., New York, August 15, 1918



The best-known trade-mark in the world

“The Victor talking machine’s design, ‘His Master’s Voice,’ has become a household word, and the quaint little fox terrier at attention before the horn is familiar to more Americans than any of the world’s great masterpieces”—*Collier’s Weekly*.

The Highest Class Talking Machine in the World

THE INSTRUMENT OF QUALITY

Sonora

CLEAR AS A BELL



Keeps your bank balances at high levels!



THE GRAND

Read this extract from a letter received from a large Sonora jobber, think it over and then write us regarding a Sonora agency:

"You are certainly doing wonders to bring the phonograph business to the front in the proper way and we have adopted your cash payment plan. You would be surprised to know the small quantity of instruments our dealers have out on time payment. We called today on a number of our best dealers who have sold over \$5000 worth of Sonoras and *none of these dealers had over three instruments out on time payment out of their entire sales.* They advised us that they have no difficulty in selling Sonoras for cash, and they are not bothered by department stores which sell phonographs at \$1 down and \$1 a week. Keep up your good work, Mr. Brightson, as you are on the right road."

SONORA is the instrument of magnificent beauty, famous as being the phonograph which won highest score for tone at the Panama-Pacific Exposition.

Sonora is the finest instrument it is possible to produce and its many exclusive and superior features make it matchless. It is purchased by those who demand the *best*. It is purchased by those who can pay *cash*. It keeps your bank balances strong and does away with the worries of large outstanding accounts. *The Sonora is the instrument bought for value and sold on a sound financial basis.*

Write us today for information

\$50	\$55	\$60	\$75	\$120	\$135	\$175
\$190	\$215	\$230	\$300	\$375	\$500	\$1000

Art Models made to special order to suit any taste

Sonora Phonograph Sales Company, Inc.

GEORGE E. BRIGHTSON, President

Executive Offices: 279 Broadway New York

Sonora operates and is licensed under BASIC PATENTS of the phonograph industry

The Talking Machine World

Vol. 14. No. 8

New York, August 15, 1918

Price Twenty-five Cents

MICKEL BROS. CO. BUY BUILDING

Purchase Structure Where Headquarters Are Now Located in Des Moines—Some Interesting Visitors—A Worthy Service Flag

DES MOINES, IA., August 5.—George E. Mickel, general manager of the Mickel Bros. Co., Victor wholesalers in this city, recently purchased the structure in which the company's business is located at 411 Court avenue. The building is a four-story and basement brick structure, 133 by 22 feet, and is located in the heart of the Des Moines wholesale district, convenient to the business center of the city and to the freight terminals and depots, and will be known hereafter as the Mickel Building.

Among the recent visitors to the Mickel Bros. Co. were Mark W. Duncab, of Albia, Ia.; L. P. Heinrich, of the Heinrich Drug Co., Osceola, Ia.; H. J. Schalekamp, of Sioux Center, Ia., and J. F. Baylor, of the Baylor Furniture Co., What Cheer, Ia. Another visitor of note was Harry Z. Swartz, manager of the Victrola department of Roshek Bros. Co., Dubuque, Ia., who reported that his company was moving the Victrola department from the third floor to the second floor of the building and installing three large demonstrating booths. Mr. Swartz reports exceptional success with the Victor Marconi wireless course.

W. P. Beale, manager of the Mickel Bros. Co., Des Moines, has returned from a business and pleasure trip through the West, visiting various points in Colorado, Wyo.

A service flag with eight stars now adorns the Mickel Bros. Building, four of the stars being credited to the local store, for E. W. Lundquist, who travels in eastern Iowa is now at an Officers' Training Camp in Kentucky; Don Peters and Roy Banta, of the company's staff, are at Camp Cody, and Harold Anderson is in France. Incidentally, Hugo Heyn, sales manager of the Omaha store, is playing with Sousa in the Great Lakes Naval Training Station Band.

GIVES A GOOD ACCOUNT OF HIMSELF

Lieut. J. A. Cromelin, Whose Family Is Well Known in the Industry, Severely Wounded

Lieut. John A. Cromelin, of 400 River street, Hackensack, N. J., an officer in the Twelfth Field Artillery, now in service in the Western front in France, is listed in recent casualty lists as severely wounded. In a letter to his mother, however, Lieutenant Cromelin describes his wounds as slight, but details have just been received from France which indicate that the lieutenant, with customary American bravery, belittled his sacrifices and injuries in order to avoid worrying those at home.

According to the official reports Lieutenant Cromelin, who is a son of Paul Cromelin, formerly vice-president of the Columbia Graphophone Co., and a nephew of John Cromelin, general sales manager of the Otto Heineman Phonograph Supply Co., was subject to an attack of German machine gunners at a distance of ten feet. Three bullets went into one of his arms side by side and two through his right leg. He is now recovering from his wounds, and is anxious to return to the firing line.

Lieutenant Cromelin was a junior at Princeton University when war was declared. He entered the First Reserve Officers' Training Camp at Fort Meyer, Va., and was assigned to the Twelfth Field Artillery, sailing for France last January. His father, Paul Cromelin, was for many years one of the most prominent members of the talking machine industry here and abroad, and at the present time is president of the Inter-Ocean Film Corp. of Manhattan.

TALKING MACHINE EXPORTS GROW

Exports, Including Records, for Eleven Months Ending May 31, Totaled \$4,363,496, as Compared With \$3,247,006 for Same Period of 1917

WASHINGTON, D. C., August 5.—In the summary of exports and imports of the commerce of the United States for the month of May, 1918 (the latest period for which it has been compiled), which has just been issued, the following figures on talking machines and records appear:

The dutiable imports of talking machines and parts during May, 1918, amounted in value to \$26,033, as compared with \$22,333 worth, which were imported during the same month of 1917. The eleven months' total ending May, 1918, showed importations valued at \$310,757, as compared with \$435,748 worth of talking machines and parts imported during the same period of 1917.

Talking machines to the number of 9,986, valued at \$337,865 were exported in May, 1918, as compared with 6,615 talking machines, valued at \$184,071 sent abroad in the same period of 1917. The eleven months' total showed that we exported 88,319 talking machines, valued at \$2,506,617, as against 69,221 talking machines, valued at \$1,797,028 in 1917, and 36,819 talking machines, valued at \$1,081,815 in 1916. The total exports of records and supplies for May, 1918, were valued at \$203,489, as compared with \$192,448 in May, 1917. For the eleven months ending May, 1918, records and accessories were exported, valued at \$1,856,879, as compared with \$1,449,987 in 1917, and \$867,795 in 1916.

PROMINENT VISITOR FROM INDIA

Valabhdas Runchordas, of the Talking Machine & Indian Record Co., Bombay, at Present in the United States in Connection With Establishment of a Record Plant in India

Valabhdas Runchordas, sole proprietor of the Talking Machine & Indian Record Co., of Bombay, India, and with branches in Calcutta and Madras, is at present in San Francisco, and plans an extensive tour of the United States for the purpose of studying the record-making situation and trade conditions generally, in the furtherance of the business plans of his house for the future.

Mr. Runchordas was one of the founders and is now sole proprietor of Valabhdas Runchordas & Co., Bombay, the importing division of the Talking Machine & Indian Record Co., being among the pioneers in the phonograph importing field in that country. Before the war the company had a practical monopoly of the products of the Beka Record Co., of Berlin, in India, Burma and Ceylon, and also featured Odeon records extensively.

It is the plan of the Talking Machine & Indian Record Co. to start a factory in India for the making of records, and Mr. Runchordas' present tour is in the furtherance of that project. Just before the outbreak of the present war Mr. Runchordas visited Switzerland and England, and on his present tour stopped in Japan for a month before coming to San Francisco. His present address in this country is care of the International Banking Corp., San Francisco.

INITIATIVE PLAYS NO FAVORITES

Initiative made of an unknown Corsican the most famous conqueror in history. Less than a century later a train-boy out in Michigan tied up to it—and the result was Edison, master of modern miracles. Initiative plays no favorites. It would just as soon transform a \$10-a-week messenger into the head of the firm as to increase the general manager's salary \$5,000 a year.

A NEW RECORD SELLING SCHEME

How One Salesman Managed to Interest Customers in Records That Ordinarily Wouldn't Be Called for or Even Listened to

An Eastern talking machine salesman has developed a little stunt for selling slow-moving records that is worthy of passing consideration. The scheme works particularly well when there is a vacant demonstrating room at hand, and is as follows: The salesman follows the usual course of ushering the customer into a booth, inquiring as to his particular desires and testing out the records. He uses the usual selling tactics and arguments, together with some of his own devising, and demonstrates as many records as possible while the customer is in the booth. When the sale is closed, however, and the customer is waiting, frequently in the passageway, for his package and change, the salesman starts playing one of the slow-selling records in the empty booth and goes about his business. Nine times out of ten the customer will stop and listen to the record, while making inquiries regarding it, the result being that frequent sales are made of records that ordinarily would not be listened to by the average customer.

The salesman in question first attempted to play slow-selling records for the customer while the latter was still in the booth, but found that the results were not satisfactory, inasmuch as the customer felt that he had finished his business for the day and was inclined to be anxious about getting his package and going on his way. Out in the corridor, however, the customer can see the package being wrapped and does not feel that in listening, apparently by accident, to another record he is wasting his time.

One of the secrets of the success of the plan, of course, lies in selecting records of a type that will appeal to the customer, judging from the selections he has already tried out and ordered. There is a psychological appeal in this kind of salesmanship that interests.

IOWA VICTOR DEALERS TO MEET

State Association Plans Annual Convention to Be Held in Des Moines August 27-28—Interesting Addresses to Be Made at Gathering

DES MOINES, IA., August 5.—Extensive plans are now being made for the annual convention of the Iowa Victor Dealers' Association, to be held in this city on August 27 and 28. The program is a most elaborate one, covering two days, and includes a demonstration by W. O. Swenker, of the Victor; a discussion on "How to Make a Record Department Profitable"; an address by C. G. Childs, director of the recording laboratories of the Victor Co.; a patriotic address by Dr. Titus Lowe, and an address on the educational value of the talking machine by C. A. Fullerton, of the Iowa State Teachers' College, Iowa Falls, Ia. Some interesting features are also planned for the business meeting of the association.

The entertainment features include a special luncheon on August 27, an informal banquet the same evening, and a trip to Camp Dodge as the final event of the convention, on the afternoon of August 28. The chairman of the official entertainment committee, reports that from present indications there will be a large number of dealers in attendance at the meeting from all parts of the State.

The officers of the association are: Charles Gaston, Gaston Music Co., Hastings, Neb., president; J. E. Gaskill, Gaskill Music Co., Nebraska City, Neb., vice-president; H. S. Thorpe, Huse Publishing Co., Norfolk, Neb., treasurer, and W. E. Mickel, Mickel Bros., Omaha, secretary.

Now Is the Time to Build Up a Cash Reserve For the Future by Proper Business Methods

Leading wholesalers and retailers in talking machines throughout the country are as one in agreeing that the thing for the retailer to do just now is to conserve his stock by selling machines only to those who are in a position to pay cash, or who are able and willing to make terms that will clean up payments within a very limited time.

In this connection a well-known wholesaler expressed himself as follows to a World representative: "With conditions such as exist at present and machines and records constantly becoming scarcer, and with little prospect of any general increase in supplies from the factories until the war is over, the dealer who has any idea of staying in business permanently must do everything in his power to conserve his stock and make every dollar invested in his business produce a cash profit within a very limited time. In many sections of the country, particularly where war industries are located, there are bound to be more prospective purchasers of machines and records than there are supplies available. This means that the retailer can practically demand his own terms of payment, and under average conditions hold out for cash. I know dealers to-day who are letting machines go out of their stores only when paid for entirely in cash, and although they are naturally refusing some orders from those who desire to open instalment accounts, they are finding enough business left to take care of available supplies of machines and records on hand, as well as supplies that they hope to obtain in the near future.

"It is very true that the old class of buyer has been trained to expect easy terms. He has had drummed into him through newspaper advertising and personal solicitation that talking machines may be purchased on terms as low as a dollar down and fifty cents a week, and has formed the opinion from advertisements in some cases that a real dyed-in-the-wool talking machine dealer would be moved to refuse cash if it were offered to him, as not being a good business practice. It may be that it will be hard to bring these people around to the new way of thinking and ask them to pay cash for a machine, or clean up the account in three or four months, but at the same time it must be remembered that there is a new class of workers coming along—a class made up of people who in

the past traveled close to the edge of poverty and who had hardly enough for food, clothing and shelter, to say nothing of the comforts of life—and many of these people are feeling the touch of wartime prosperity. They are earning two, three or four times as much as in peace times. Their forced training in economy has in a great many cases stood them in good stead, and they have cash to buy those things that they had desired, which, of course, include talk-

Substantial Selling Terms and Energetic Collection Keys to Dealers' Salvation In These War Days

ing machines of the better type. The dealer, therefore, who wants to follow a new line of business practice need not fear that he is going to lose the market. Without question he will lose more business through not being able to supply the goods than he will through refusing to tie up his investment in a machine for a year or more.

Never was cash so valuable as now. The dealer must have cash to meet his taxes, his increasing living expenses, his clerk hire and other interests of a similar nature. The Government, his landlord and his clerks are none of them going to accept instalment paper in lieu of legal tender. Then again, while in normal times the dealer might have little difficulty in borrowing from his bank on instalment paper, he is going to find under the present conditions that the banks are cutting right and left into the credit extended along that line, even with old customers, and are not at all enthusiastic about accepting new paper as collateral, all of which should make the cash customer welcome to the talking machine dealer, and worth being sought after. Meanwhile, while observing the

new trade practice in the matter of selling, the dealer should find plenty of opportunity for getting after slow and dormant accounts, cleaning them up with all possible despatch and not hesitating to repossess a machine when it looks as though there was little hope for a satisfactory financial settlement.

If the war continues much longer a second-hand talking machine is going to be a fairly salable proposition. If the average retailer does not believe this, let him try and buy a few second-hand machines from some of his fellow dealers. He will find in most cases they are being saved for emergencies and not for sale to the trade. If, with his accounts in first-class shape, and with his new sales on short time or cash, the retailer is called upon to meet a certain crisis, he will find himself in a much better position to rise to the situation and possibly save his business. Some such situations are going to arise with the coming of peace, whether it is a matter of a few months or a matter of years. With the economic reorganization of the country along the lines of business, and with supplies of machines and records getting back to normal, the dealer with a lot of slow accounts and little cash is going to find it hard sledding in competing with the fellow who has observed properly wartime practices and has cash with which to go into the market, restock his shelves, and resume again the development of business.

The whole question of the future of the individual dealer would seem at the present time to revert around the conservation of stock on hand, and the limited stock he will be able to get, and the main factor in this work of conservation is the observance of terms that are going to give the dealer a maximum of cash returns in a minimum time. If he has leisure on his hands, it is much better to spend that time selling than trying to collect on old accounts.

F. A. MULFORD WITH HOFFER BROS.

F. A. Mulford, formerly manager of the retail department of Harger & Blish, Des Moines, Ia., the prominent Edison Diamond Disc phonograph jobbers, has resigned from that position and is now in charge of the Edison department of Hoffer Bros. in Norfolk, Va.

SINCERITY

That's the slogan back of every factor in

Ditson Service

It means much just now

Oliver Ditson Co.
B O S T O N

VICTOR
Exclusively

Chas. H. Ditson & Co.
N E W Y O R K

Victrola IV-A, \$22.50
Oak

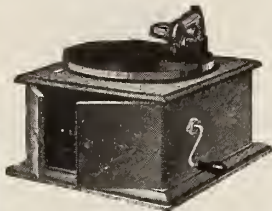

Victrola VIII-A, \$50
Oak



Victrola X-A, \$90
Mahogany or oak



Victrola XVI, \$225
Victrola XVI, electric, \$282.50
Mahogany or oak.

Victor Supremacy

Supreme as a musical instrument, the Victrola naturally stands supreme as a business proposition.

The success of Victor retailers follows Victor supremacy as a matter of course.

Victor Talking Machine Co. Camden, N. J., U. S. A.

Berliner Gramophone Co., Montreal, Canadian Wholesalers

"Victrola" is the Registered Trade-mark of the Victor Talking Machine Company designating the products of this Company only.

Warning: The use of the word Victrola upon or in the promotion or sale of any other Talking Machine or Phonograph products is misleading and illegal.

Important Notice. Victor Records and Victor Machines are scientifically co-ordinated and synchronized in the processes of manufacture, and their use, one with the other, is absolutely essential to a perfect reproduction.



Victor Wholesalers

Albany, N. Y.... Gately-Haire Co., Inc.
 Atlanta, Ga..... Elyea-Austell Co.
 Phillips & Crew Piano Co.
 Austin, Tex..... The Talking Machine Co., of
 Texas.
 Baltimore, Md.... Cohen & Hughes.
 E. F. Droop & Sons Co.
 H. R. Eisenbrandt Sons, Inc.
 Bangor, Me..... Andrews Music House Co.
 Birmingham, Ala. Talking Machine Co.
 Boston, Mass.... Oliver Ditson Co.
 The Eastern Talking Machine
 Co.
 The M. Steinert & Sons Co.
 Brooklyn, N. Y... American Talking Mch. Co.
 G. T. Williams.
 Buffalo, N. Y.... W. D. & C. N. Andrews.
 Neal, Clark & Neal Co.
 Burlington, Vt.... American Phonograph Co.
 Butte, Mont..... Orton Bros.
 Chicago, Ill..... Lyon & Healy.
 The Rudolph Wurlitzer Co.
 Chicago Talking Machine Co.
 Cincinnati, O.... The Rudolph Wurlitzer Co.
 Cleveland, O.... The W. H. Buescher & Sons
 Co.
 The Collister & Sayle Co.
 The Eclipse Musical Co.
 Columbus, O.... The Perry B. Whitsett Co.
 Dallas, Tex..... Sanger Bros.
 Denver, Colo.... The Hext Music Co.
 The Knight-Campbell Music
 Co.

Des Moines, Ia.... Mickel Bros. Co.
 Detroit, Mich.... Grinnell Bros.
 Elmira, N. Y..... Elmira Arms Co.
 El Paso, Tex..... W. G. Walz Co.
 Honolulu, T. H.... Bergstrom Music Co., Ltd.
 Houston, Tex.... Thos. Goggan & Bro.
 Indianapolis, Ind. Stewart Talking Machine Co.
 Jacksonville, Fla.. Florida Talking Machine Co.
 Kansas City, Mo.. J. W. Jenkins Sons Music Co.
 Schmelzer Arms Co.
 Lincoln, Nebr.... Ross P. Curtice Co.
 Little Rock, Ark.. O. K. Houck Piano Co.
 Los Angeles, Cal. Sherman, Clay & Co.
 Memphis, Tenn.... O. K. Houck Piano Co.
 Milwaukee, Wis... Badger Talking Machine Co.
 Minneapolis, Minn. Beckwith, O'Neill Co.
 Mobile, Ala..... Wm. H. Reynolds.
 Montreal, Can.... Berliner Gramophone Co.,
 Ltd.
 Nashville, Tenn.... O. K. Houck Piano Co.
 Newark, N. J..... Price Talking Machine Co.
 New Haven, Conn. Henry Horton.
 New Orleans, La... Philip Werlein, Ltd.
 New York, N. Y.... Blackman Talking Mach. Co.
 Emanuel Blout.
 C. Bruno & Son, Inc.
 I. Davega, Jr., Inc.
 S. B. Davega Co.
 Charles H. Ditson & Co.
 Landay Bros., Inc.
 New York Talking Mach. Co.
 Ormes, Inc.
 Silas E. Pearsall Co.

Omaha, Nebr..... A. Hospe Co.
 Mickel Bros. Co.
 Peoria, Ill..... Putnam-Page Co., Inc.
 Philadelphia, Pa.. Louis Buchn Co., Inc.
 C. J. Heppes.
 The George D. Ornstein Co.
 Penn Phonograph Co., Inc.
 The Talking Machine Co.
 H. A. Weymann & Son, Inc.
 Pittsburgh, Pa.... W. F. Frederick Piano Co.
 C. C. Mellor Co., Ltd.
 Standard Talking Machine Co.
 Portland, Me..... Cressey & Allen, Inc.
 Portland, Ore.... Sherman, Clay & Co.
 Providence, R. I... J. Samuels & Bro., Inc.
 Richmond, Va.... The Corley Co., Inc.
 W. D. Moses & Co.
 Rochester, N. Y... E. J. Chapman.
 The Talking Machine Co.
 Salt Lake City, U. Consolidated Music Co.
 The John Elliott Clark Co.
 San Antonio, Tex. Thos. Goggan & Bros.
 San Francisco, Cal. Sherman, Clay & Co.
 Seattle, Wash.... Sherman, Clay & Co.
 Sioux Falls, S. D.. Talking Machine Exchange.
 Spokane, Wash.... Sherman, Clay & Co.
 St. Louis, Mo.... Koerber-Brenner Music Co.
 St. Paul, Minn.... W. J. Dyer & Bro.
 Syracuse, N. Y.... W. D. Andrews Co.
 Toledo, O..... The Whitney & Currier Co.
 Washington, D. C. Cohen & Hughes.
 E. F. Droop & Sons Co.
 Rolt. C. Rogers Co.

AN IMPORTANT ACCESSORY—ALBUMS FOR FILING DISC RECORDS

The enormous demand for "National" Record Albums keeps pace with the ever increasing demand for machines and records, and our output capacity has been enlarged to meet the greater needed supply. Record Albums have proven themselves to be the best and most convenient, as well as economic, method of filing and keeping disc records.



MAKING THEIR SELECTION

Illustrating the daily actual usage of the Album, the most convenient and satisfactory record filing system extant.

THE ALBUM

soon pays for itself in time-saving and preserving records. The initial cost is really an investment which comes back fourfold.

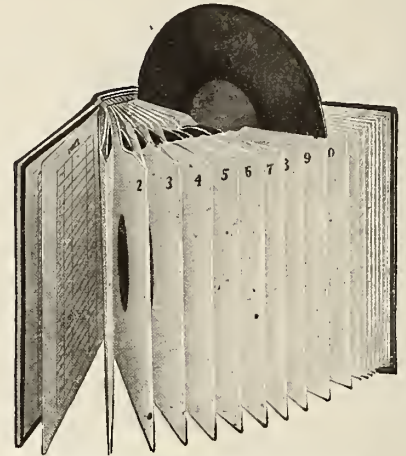

THE PERFECT PLAN

The pockets holding the records are substantially made from strong fibre stock, firmly joined together and bound in attractive covers.

A PLACE FOR EVERY RECORD AND EVERY RECORD IN ITS PLACE

Albums are an **Indispensable Requisite** in the talking machine business and wherever records are sold. An accessory that is necessary and worth while. Practical and handy. Save time and records. A **profitable adjunct** to the business. All owners of machines and records want Albums to file and preserve their records.

We manufacture disc Record Albums containing 12 pockets to fit cabinets of all sizes and styles. We also make Albums containing 17 pockets. With the indexes they are a complete system for filing all disc records.

For durability, finish and artistic design, our Albums are unsurpassed. We have unexcelled manufacturing facilities, and considering quality our prices are the lowest. Write us, giving quantity you may desire, and we will quote prices.

OUR ALBUMS ARE MADE TO CONTAIN VICTOR, COLUMBIA, EDISON, PATHÉ AND ALL OTHER DISC RECORDS

NATIONAL PUBLISHING CO. : 239 S. American Street : PHILADELPHIA, PA.

SEND-OFF FOR L. L. LEVERICH

Assistant Advertising Manager of the Columbia Co. Leaves for Camp Upton—Gets Wrist Watch From Associates Before Departure

Lester L. Leverich, assistant advertising manager of the Columbia Graphophone Co., New York, left Wednesday, July 24, for Camp Upton as a member of the contingent from his district. Mr. Leverich had been expecting this call for several weeks, and had made all the necessary arrangements to leave for camp.

On the day preceding his departure for Camp Upton Mr. Leverich was the guest of honor at a dinner tendered him by his former associates of the advertising department and other members of the publicity and sales forces. R. W. Knox, advertising manager of the Columbia Co., presided at this dinner as toastmaster, and Mr. Leverich was presented with a handsome wrist watch, which will serve as a permanent reminder of the esteem and friendship of his former associates. Among those who attended this dinner, which was held at Keen's Chop House, were the following: Lester L. Leverich, R. W. Knox, Wm. Harden, Paull Hayden, O. F. Benz, Courtland Shaw, Jr., W. A. Schreiner, Walter Bruner, Chas. Wolfe, Ray Ladue and a bevy of young ladies from the advertising department.

Lester Leverich has been associated with the Columbia Graphophone Co. for six years as a member of the company's advertising department. He is thoroughly familiar with all the details of Columbia publicity activities, and his recent promotion to the post of assistant advertising manager was a well-deserved tribute to his many years of hard work. He is anxious to "do his bit," and it is his earnest hope that he will soon be "over there," and in active service.

W. A. ANDRESEN NOW PRESIDENT

John C. Andresen, president of the Columbia Mantel Co., talking machine and cabinet manufacturers of Brooklyn, N. Y., passed away recently at the age of seventy years. He organized the present industry, of which he was the head, thirty-five years ago, and continued active in its management until five days before his death. He had a large acquaintance in the trade and enjoyed an enviable reputation for integrity among those who had business dealings with him.

At a directors' meeting held on July 16 it was voted to continue business in the usual way. W. A. Andresen, son of the deceased, was elected president of the company, with C. H. Gudegast continuing as secretary, and also directing the sales management.

WHY NOT "WILL YOU PAY FOR IT?"

Salesmen Should Ask This Question More Frequently So As to Encourage Cash Sales

The talking machine department of a retail house discovered that its charge accounts were increasing in a manner out of proportion to its cash sales increase. The proprietor did not simply take this situation for granted, but asked the reason. The credit man, after a little questioning, found the answer. It was in the way salesmen closed the order. They said, "Shall we charge it?" instead of "Will you pay cash for it?" or "Do you have an account here?" With the instructions not to suggest to a customer that he open an account for his purchase and charge it, it was soon discovered that the increase in cash sales held up in better proportion than it had to the increase in charge sales.

BLISNICK IN CHARGE AT HAHNE'S

NEWARK, N. J., August 1.—R. S. Fink, who has been in charge of the Victor department of Hahne & Co., Newark, N. J., has joined the Naval Reserves. J. S. Blisnick, who has been a member of the Hahne & Co. staff for the past twelve years, has taken charge of the above department. Hahne & Co. is one of the largest department stores in this city, and the selection of Mr. Blisnick to fill the vacancy in the Victor department promises well for its future.

LEARNING FRENCH BY "TALKER"

A recent cable from Paris says that the Knights of Columbus have arranged to give instruction in the French language to American soldiers in training camps throughout the country. Talking machines have been installed in every K. of C. clubhouse in the big cantonments, and records furnishing a complete course in conversational French have been sent to the general secretaries at the camps. French instructors have also been employed.

A really good Album at a moderate price is a money maker for the dealers. NYACCO Metal Back Albums will give the dealer and his patrons true value and the highest quality.

A complete line of Albums that stand for the best in their respective grades.



Write for samples of our three numbers

NEW YORK ALBUM & CARD CO.
23-25 LISPENARD STREET - NEW YORK

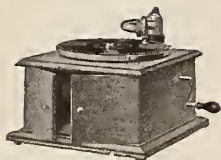

Victrola IV-A, \$22.50
Oak

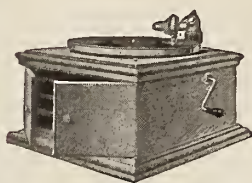

Victrola VI-A, \$32.50
Oak



Victrola VIII-A, \$50
Oak



Victrola IX-A, \$60
Mahogany or oak



Victrola X-A, \$90
Mahogany or oak



Victrola XI-A, \$115
Mahogany or oak

Victor Supremacy

The supremacy of the Victrola marks it as the greatest of all musical instruments.

And with genuine Victrolas in such splendid variety, possibilities are unlimited for every Victor retailer.

Victor Talking Machine Co.
Camden, N. J., U. S. A.

Berliner Gramophone Co., Montreal, Canadian Wholesalers

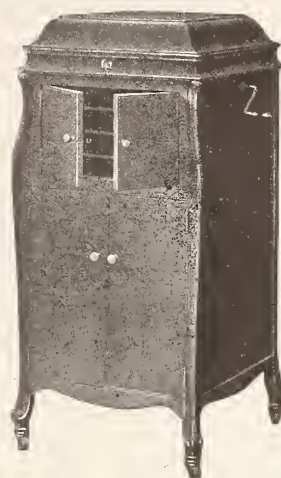

Victrola XIV, \$175
Mahogany or oak



Victrola XVI, \$225
Victrola XVI, electric, \$282.50
Mahogany or oak



Victrola XVII, \$275
Victrola XVII, electric, \$332.50
Mahogany or oak

"Victrola" is the Registered Trade-mark of the Victor Talking Machine Company designating the products of this Company only.

Warning: The use of the word Victrola upon or in the promotion or sale of any other Talking Machine or Phonograph products is misleading and illegal

Important Notice. Victor Records and Victor Machines are scientifically co-ordinated and synchronized in the processes of manufacture, and their use, one with the other, is absolutely essential to a perfect reproduction.



"HIS MASTER'S VOICE"
REG. U.S. PAT. OFF.

The TALKING MACHINE WORLD

For the makers & sellers of talking machines

PUBLISHED BY EDWARD LYMAN BILL, Inc.

President, C. L. Bill, 373 Fourth Ave., New York; Vice-President, J. B. Spillane, 373 Fourth Ave., New York; Second Vice-President, J. Raymond Bill, 373 Fourth Ave., New York; Secretary and Treasurer, August J. Timpe, 373 Fourth Ave., New York.

J. B. SPILLANE, Editor

J. RAYMOND BILL, Associate Editor

AUGUST J. TIMPE, Business Manager

Trade Representatives: B. BRITTAIN WILSON, L. M. ROBINSON, WILSON D. BUSH, C. CHACE, E. B. MUNCH, L. E. BOWERS, A. J. NICKLIN, V. D. WALSH

Boston: JOHN H. WILSON, 324 Washington Street

Chicago Office: E. P. VAN HARLINGEN, Republic Building, 209 South State Street. Telephone, Wabash 5774

London, Eng., Office: 2 Gresham Buildings, Basinghall St. W. LIONEL STURDY, Mgr. The Talking Machine World has regular correspondents located in all of the principal cities throughout America.

Published the 15th of every month at 373 Fourth Ave., New York.

SUBSCRIPTION (including postage): United States, Mexico, \$2.00 per Year; Canada, \$2.25; all other countries, \$3.75. Single copies, 25 cents.

ADVERTISEMENTS: \$4.50 per inch, single column, per insertion. On quarterly or yearly contracts a special discount is allowed. Advertising pages, \$125.00.

REMITTANCES should be made payable to Edward Lyman Bill, Inc., by check or Post Office Money Order.

NOTICE TO ADVERTISERS.—Advertising copy should reach this office by the first of each month. By following this rule clients will greatly facilitate work at the publication headquarters.

**Long Distance Telephones—Numbers 5982-5983 Madison Sq.
Cable Address: "Elbill," New York.**

NEW YORK, AUGUST 15, 1918

AS the war goes on, and as the country bends its great energies more and more to the preparation for, and conduct of, hostilities, calling upon the resources of the nation to an unprecedented extent, the problems of those in non-war industries continue to multiply. These problems are apparent in the talking machine trade, as in other lines of endeavor, and many important and serious developments have already materialized, and more promise to materialize, in the very near future, unless peace should come with unexpected suddenness. These problems have all pointed to the absolute necessity of a closer co-ordination between the various factors of the industry.

It is high time to forget petty jealousies and to meet together on a common footing. It is not a question whether the individual factor is large or small, the fact remains that the trade is considered as one industry, and that as one industry it must face the problems put up to it by the exigencies of war, and the rulings and orders of those charged with the destinies of the Government. What is needed is not simply a temporary committee, even though composed of competent men, but rather a strong, central organization, or preferably a strong representative—a man allied to no one factor in the industry, but who, being independent and viewing the situation with unbiased mind, can serve the industry in its dealings with the Washington authorities.

We have seen the need of such a man, or such a concentrated representative, in the handling of the curtailment question and more recently in the matter of the new War Revenue Bill and the steel supply. It may be that the talking machine trade will pull through uninjured, and it may, and it is hoped it will, receive favorable consideration in the matter of the allotment of supplies and in the imposing of tax levies, but until the final outcome there is, and must be, a period of uncertainty—an uncertainty that possibly would not prevail were there a representative at Washington able to get in touch with the authorities in the name of the entire industry, and reach some definite agreement on matters now pending. Other industries have followed this plan and their success has been apparent, and the quicker the talking machine trade as a whole realizes the fact and gets down to business, the better off it will be.

The new War Revenue Bill in its final analysis may be eminently fair to the industry. Supplies of steel may finally be sufficient to keep things running to a satisfactory degree in view, of course, of the general situation, but men with estab-

lished businesses at stake cannot flirt with possibilities. They must organize their forces to see that they are properly represented before the councils of the nation. We are not not dealing with the present, when things are more or less serene, but with the future, and the outlook is not one that should encourage the average manufacturer to rest easy and let things take their course without at least having a chance to present his case and have a hearing.

JUST as the question of supply and demand regulates prices in other fields where selling prices are not established or fixed, so should that same question of supply and demand at least regulate the terms upon which talking machines and records are sold during these war days. It is revealing no secret to say that supplies of both machines and records are going to become scarcer before they become more plentiful, as war conditions make themselves felt to a greater degree.

The talking machine dealer on the other hand finds that his cost of doing business is steadily on the increase; his help costs him more; he has new taxes to meet, his own cost of living is jumping upward, and every factor that goes into his overhead is away above normal and keeps getting higher. His margin of profit on the machine and record unit is practically fixed and, therefore, in order to offset his higher selling costs, he must depend upon improved methods.

The first thing that comes to mind, therefore, is to sell only for cash, or on terms that will represent cash in a very few months. This will mean that the dealer has the cash on hand to turn over his stock more quickly where possible. He is able to conserve his capital, and when the dawn of peace arrives, will find himself financially sound with actual cash, instead of notes in his bank, with which to start out again along the paths of peace—with money to restock and to begin again the building up of his business.

Make every dollar count, and this can only be accomplished by watching terms; by making every cent invested in the business bring in a profit with reasonable promptitude. It is no time for a dollar down and fifty cents a week business.

IN the figures bearing upon the exports and imports of talking machines and records which appear elsewhere in *The World*, it is rather noteworthy as emphasizing the development of the industry to bring to the attention of readers the fact that the exports of talking machines and records for the eleven months ending May 31, which amounted in value to \$4,363,496, are rapidly approaching the entire shipments of pianos, players, organs, music rolls, and, in fact, musical instruments and merchandise of all kinds, for the same period, the exports of the latter amounting in value to \$4,570,706. This is probably the first year that the exports of talking machines and records have made such a close approach to the exports of the old-time instruments, which demonstrates that the industry is becoming a real factor in the great mercantile activities of America.

A DEVELOPMENT of the labor problem that must appeal to members of the talking machine trade, as well as to men in every other industry, is that of utilizing the labor of soldiers crippled in the war and sent back into civilian life to make their living in peaceful pursuits. This question is rather new to the United States, because the cripples have not yet come home from the battlefield in any considerable number, but the French, English and Canadians have faced the problem in all its perplexities, and from their experience we know that it is something that must be prepared for seriously and carefully. There will be thousands—maybe hundreds of thousands—of men coming back from Europe unfitted through wounds or mutilations for taking up their pre-war activities. Many of them will be close to physical wrecks, but for the economic welfare of the nation they must be fitted somewhere in the industrial fabric. The talking machine industry, as well as other industries, must prepare to take its share of this work and make room for those who may be fitted to do certain work in the factories and stores. The Talking Machine World has learned of at least once instance where a returned fighter has taken up the study of repairing machines with considerable success. Shrapnel wounds left him physically unable

to lift even medium heavy weights. He still has the use of all his faculties and he has already made progress in this new field. There is no reason why partially disabled men cannot find a place in record departments, repair departments and various sections of manufacturing plants where the work is more or less mechanical, or where it is not heavy enough to require physical strain.

Taking care of the returned soldiers is going to be a big problem in this country. Making a place for war cripples is even a bigger question, and a question that should receive attention right now.

BUSINESS in the talking machine industry for the past month has shown a slight slowing-up at least in some sections of the country. Meanwhile, a shortage of stock continues to prevail in certain makes and in certain styles. As the war in Europe progresses, a greater demand is being made on manufacturers for space and equipment to make war supplies for the Government, and this activity is having its effect particularly in the curtailment of the production of accessories for the talking machine trade. The industry is especially short of steel, and this is being felt by a great many manufacturers of all kinds of supplies. Efforts are being made, however, to better conditions, to the end that steel production will be speeded so that there will be a surplus left from Government requirements for the smaller industries, where the use of steel is comparatively insignificant, nevertheless, important.

Late last month talking machine manufacturers held a meeting in New York, and decided to send out questionnaires to manufacturers so as to get the fullest information regarding the exact amount of steel needed by the industry, after which a committee will get in touch officially with the authorities in Washington and present facts for their consideration that will merit their attention so that the needs of the talking machine industry are supplied, at least, in part.

Members of the industry have been greatly interested the past month in the recommendations of the Treasury Department, which in a letter to the Ways and Means Committee suggested 20 per cent. taxes on a number of so-called "luxuries," among which were included talking machines and records. The formulation by the Treasury Department of this high tax evidently did not have weight with the Ways and Means Committee, for the first of the month Congressman Kitchin announced that a proposed tax of 10 per cent. on talking machines and records would be placed before the House of Representatives for consideration. This increase of 7 per cent. over the old tax, which was 3 per cent., is considered by members of the trade to be far too high and it is believed that a total tax of 5 per cent. should be the limit, if any increase is necessary.

It is hoped, however, when the new Revenue Bill comes up

TO OUR SUBSCRIBERS

If your copy of The Talking Machine World does not reach you on publication date, or a few days thereafter, do not assume that it has gone astray. The existing railway congestion has had a serious effect on the handling of mail, particularly second class matter, and brought about unusual delays. Kindly wait a few days longer than usual before writing to us, as the paper will probably arrive safely.

for consideration in the House of Representatives, that the facts presented by the industry will compel our legislators to give closer consideration to the fact that talking machines and records are an absolute necessity in these war days. The Government itself is recognizing this fact by its orders for musical instruments for the Army and Navy. Music is now widely recognized as a requirement in the maintenance of the morale of the Army and Navy as well as the people of this country, and there is no medium which better expresses all forms of music than the talking machine.

IT is regrettably true that there are men to-day in business who have misgivings regarding the power of advertising. Men holding such views are not clear, sound thinkers, because the house that uses advertising persistently and intelligently always scores success in the battle for business. This has been demonstrated most emphatically in the talking machine field. The houses that have reached the top notch of success are those that believe in printer's ink, and in advertising in its varied forms. In this connection it is interesting to print the views of the President of the Chamber of Commerce of the United States, who said recently:

"If there are still extant men who ask the question, 'Does it pay to advertise?' I know their thinking is of the kind which would lead them to light factories with candles and insist upon the advantages which would accrue if the residents of modern cities still drew their water supply by bucket from the town well.

"When nations in the greatest struggle of history advertise for armies; when kings and emperors and sultans come down from their thrones to seek the attention of the world and present their pleas and defenses through the press; when it has become the daily bread of a large part of the world's business, it is indeed a man of limited mentality who still questions the power of publicity.

"Its value to society has, in fact, so impressed itself that to-day publicity is the light of the world. It may be said, with little element of speculation in the assertion, that if publicity had characterized dealings between the nations of Europe during the past fifty years, and secret diplomacy had been eliminated, the present world war, with its terrorism and threat to all civilization, would not now be raging."

This is the truth; and the truth will prevail.

Ship Ahoy!

LET the skipper of this craft throw you a line on your next "short" order.

Pearsall Service sails through chartered seas, and while the delivery waves at present are rough, we may be able to layup to your wharf with surprising shipments.

From port to starboard; from bow to stern; Pearsall Service on Victor Records keeps your profits anchored.

Silas E. Pearsall Co.

Wholesale Distributors of Victrolas and Records

10 EAST 39th STREET

NEW YORK



Edison Message No. 25

Reading, 'Riting, 'Rithmetic —and Music

"I believe most fully in the value of music as an important factor in the education and life of any people, and especially of a free people with a democratic form of government. The songs of a nation may not be more important than its laws, but their influence even in determining legislation and obedience to law . . . cannot easily be estimated . . . After reading, writing and arithmetic I consider music the most important and the most practical subject taught in our schools."

ALEXANDER P. CLAXTON,
U. S. Commissioner of Education.

The Edison dealer who works in close touch with his neighborhood schools can materially assist in sowing the seeds of a love of music in the children of his community.

Music-loving children are a vital factor in the future of a community of music lovers.

THOMAS A. EDISON, Inc.
ORANGE NEW JERSEY

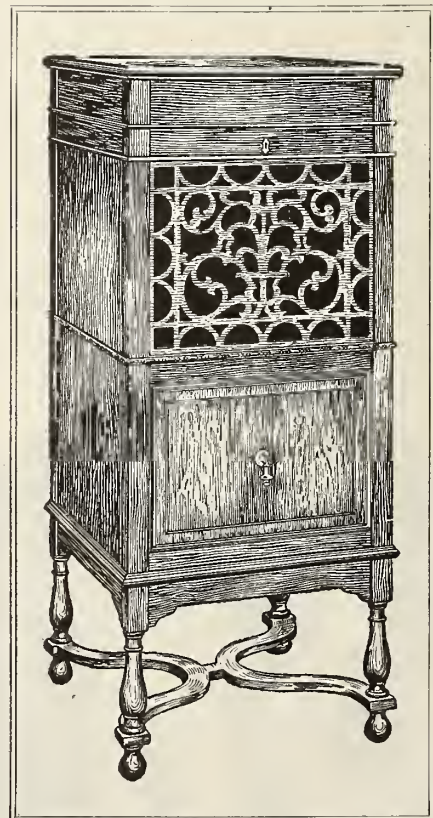

Official Laboratory Model New Edison—William and Mary Cabinet, executed in American Walnut.

Getting Away from Stereotyped Forms in the Advertising of Talking Machine Records

Cartoons by Ned C. Strouse

There are very few fields in which the individuality of the merchant can play such a large part in his success as in the talking machine trade, for by the very nature of the industry the merchant must depend upon his individuality and his originality in presenting himself and his line before the public, to distinguish himself from probably a score or more other dealers handling the same product, or a very similar product in his own particular territory. It is true that various talking machine manufacturers have spent millions of dollars during the past year in supplying their retailers with an abundance of hangers, bulletins, posters, window and street car cards, window displays and a multitude of other advertising paraphernalia, distinctly effective in its way, and for the most part to be had for the asking.

The trouble has been that too many dealers have been content to rely upon the manufacturers for their advertising ideas and to use

and selections, but it happens, particularly in the present situation, that the dealer may not have sufficient of such records to warrant any extensive exploitation, or, on the other hand,

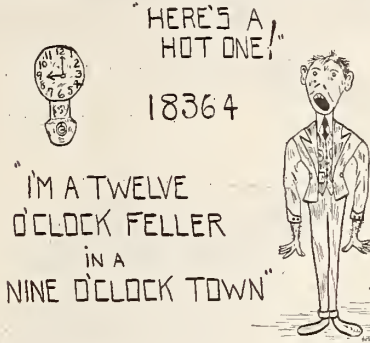

may have shelves full of other numbers that he is very desirous of moving. In this case he is thrown on his own resources, and it is here that the cultivation of individuality in advertising stands him in good stead, and pays for the attention given to it.

Each dealer knows, or should know, the type of people he desires to reach, and the sort of appeal that is most likely to bring results. He can, therefore, advertise in a most striking way and much more effectively than by the use of any general material the manufacturer sends out for use in all sections of the country. He can associate certain records with certain local events. He can bring special records to the attention of special classes of people. He can capitalize local interest in various directions in furthering the sale of records that otherwise might lie dormant on the shelves. He can inject a humorous touch into his description of certain numbers that will appeal to a certain section of his clientele and result in sales.

There have been reproduced in The World, from time to time, many publicity schemes utilized by individual dealers—schemes that have proven successful, and can thereby be considered beyond the experimental stage. A system of publicity worked in one territory may, with profit, be used in other sections of the country, where it will prove comparatively new, or the system may be altered, and changed about, to adapt it to local conditions.

The talking machine dealer who is experiencing difficulty in getting new or more popular records and still has a substantial stock of numbers that usually lie dormant must give his earnest attention to ways and means for moving those dormant numbers off his shelves, and it is a problem that only he, himself, can solve. No manufacturer can afford to give special study to his particular problem and meet it specifically. That is up to the individual, and he will often find that an introduction of the proper sort will go far to reduce his surplus of certain records. But the plan must have individuality in order that it will serve to move his records and not those of his

competitor up the street. In other words, the particular record must be associated with his store to such a degree that the prospective buyer instinctively will go to that particular shop to purchase that particular record.

As an illustration of individuality in talking machine record publicity, we reproduce here with several cards sketched by Ned C. Strouse, manager of the A. B. Clinton Co. store in Hartford, Conn., where a substantial Victrola department is maintained. Mr. Strouse, fortunately, is gifted as a cartoonist, and draws up the little sketches himself. They measure about seven by nine inches, and one is always to be found in each booth of the company's store. It frequently happens that a casual customer first begins by laughing at the humorous character of the cartoon and ends up by listening to, and finally buying, the record to which it refers. There is nothing elaborate about the sketches. They are simply in pen and ink and rely upon just a touch of comedy to make them drive home.

Mr. Strouse has followed the cartoon idea also in his local advertising in the newspapers, using space from two to three columns wide,



the material furnished them without further embellishment, and let the matter go at that. Of course, the advertising matter was, and is, of a character to attract attention, but the fact remains that possibly there are a half dozen merchants on the same street, or in the same district, handling identically the same line and using identically the same store window, newspaper and poster advertising. Under such a condition there is nothing to influence a prospective buyer to visit one store in preference to another.

Undoubtedly certain wholesalers and retailers have realized the advisability of supplementing the manufacturer's publicity with advertising creations of their own. Some jobbers have gone into this matter on a broad basis, and a large number of dealers—and they are successful dealers—have accepted the manufacturer's advertising matter simply as a means for a general introduction to the public at large, and have of their own accord issued supplementary advertising calculated to concentrate the attention of possible buyers to their particular

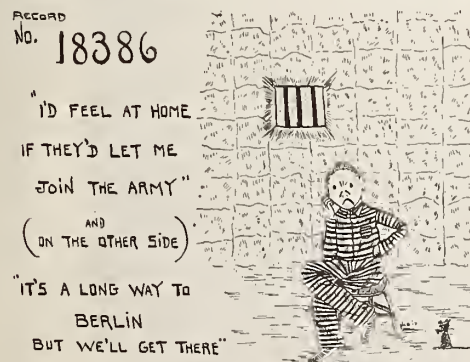

store, and to hold that attention when once obtained.

The idea has been carried out still further in many instances in the matter of record publicity. Companies have issued hangers and other material featuring special records of a popular sort, or records of better known stand-



SCHMIDT'S FUNNIGRAPHS

Being a series of advertisements appearing each Tuesday and Thursday, in which are used, as headlines, the titles of new songs. To see some of these are peculiarly humorous, while others bear a life-long sentiment.

Number 2.

"The Man Who Put Germ in Germany (What's in a Name?)"

Sung by Nora Bayes, Columbia record No. A9051. Price \$1.25. On sale after July 20

The voice of Nora Bayes is a gift. It's a character voice, one with endless changes of tone and temper.

Hear her sing this rousing, roisterous patriotic song and you will understand the meaning of the peculiar title chosen for this song.

SCHMIDT MUSIC CO.
THE QUALITY IS THE FOUNDATION OF OUR BUSINESS
11-113 W. 3rd St. Davenport, Ia.

NUMBER 4 will appear THURSDAY Page 2

An Ad That Embodies the Cartoon Idea

and four or five inches deep once, and sometimes twice, a week. Each ad consists of a timely cartoon, drawn and lettered by Mr. Strouse, and the people of Hartford soon formed the habit of looking for the cartoons and enjoying them. Naturally they associate the cartoons with the Clinton store and with the things musical to be purchased at that store. Proven results in actual business thus stimulated are most satisfactory.

Of course, not every talking machine dealer or his manager has the ability to draw cartoons, but at the same time the sketches are of a sort that can be obtained at small cost from any local sketch artist, and in cases where only one is required for display in demonstrating rooms, it will be found that the sketch will be much cheaper than special printed matter. The cartoon idea for general advertising, too, can be carried out on a comparatively inexpensive basis through the assistance of an outside artist, or in co-operation with the artists on the regular staffs of the newspapers. The idea is to get away from the beaten track, to train the public to associate instinctively these dealers' establishments with a particular product. It means more business and the building up of a following that will keep business on the increase, barring, of course, conditions over which the

(Continued on page 13)

The most wonderful Talking Machine of the present age at the price
An Instrument of Supreme Value, Tone and Quality.

Cleartone

SPEAKS FOR ITSELF



No. 100—\$100



No. 75—\$75

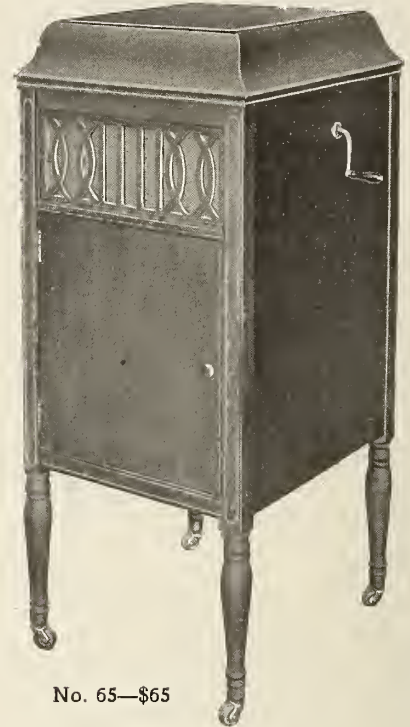

No. 65—\$65

The *Cleartone* has become very popular because of its quality, splendid value and the advertising and sales campaign that now stands in back of it. **Dealers!** Watch us grow—write for our agency and grow with us.

SUNDRY DEPARTMENT

MOTORS—No. 01, 8-in. turntable, single spring, \$1.25; same motor with 10-in. turntable, \$1.40. No. 1, 10-in. turntable, double spring, plays two 10-in. records, \$2.95. No. 6, 10-in. turntable, double spring, plays three 10-in. records, \$3.50; same motor with 12-in. turntable, \$3.85. No. 8, 12-in. turntable, cast-iron frame, double spring, plays three 10-in. records, \$4.85. No. 9, 12-in. turntable, cast-iron frame, bevel gear wind, double spring, plays three 10-in. records, \$5.85. No. 10, 12-in. turntable, cast-iron frame, bevel gear wind, double springs, plays four 10-in. records, \$6.85. No. 11, 12-in. turntable, cast-iron frame, bevel gear wind, double spring, plays seven 10-in. records, \$8.50.

TRON ARMS AND REPRDDUCERS—No. 1, \$1.00; No. 2, plays all records, \$1.25; No. 4, \$2.65; No. 6, \$2.25; No. 7, \$2.25; No. 8, \$2.25; No. 9, \$2.25. (Play all records.)

MAIN SPRINGS—No. 00— $\frac{1}{4}$ -in., 23 gauge, 9-6 ft., 20c. each, 100 lots, 25c. each; No. 01, 1-in., 23 gauge, 7 ft., 25c. each, 100 lots, 20c. each; No. 0, $\frac{1}{4}$ -in., 20 gauge, 8-6 ft., 25c. each, 100 lots, 21c. each; No. 1, $\frac{1}{4}$ -in., 25 gauge, 9-6 ft., 39c. each, 100 lots, 35c. each; No. 2, 1 $\frac{1}{2}$ -in., 25 gauge, 9-6 ft., 43c. each, 100 lots, 39c. each; No. 3, $\frac{3}{4}$ -in., 25 gauge, 11 ft., 49c. each, 100 lots, 45c. each; No. 4, 1-in., 23 gauge, 10 ft., 49c. each, 100 lots, 45c. each; No. 5, 1-in., 27 gauge, 11 ft., 65c. each, 100 lots, 59c. each; No. 6, 1 $\frac{1}{4}$ -in., 27 gauge, 11 ft., 90c. each, 100 lots, 85c. each.

RECORDS—POPULAR and GRAMMAVOX Brand, 10-

in. double face, lateral cut, all instrumental—32c. in lots of 100, 30c. in lots of 1,000, 29c. in lots of 5,000.

GOVERNOR SPRINGS—\$1.00 per hundred; \$6.00 per thousand. Special price in large quantities for Motor Manufacturers.

GENUINE DIAMOND POINTS for playing Edison Records, \$1.45 each, 100 lot, \$1.35 each; Sapphire Points for playing Edison Records, 18c. each, 100 lots, 14c. each; Sapphire Balls for playing Pathé Records, 18c. each, 100 lot 15c. each. **Needles**—Steel, 63c. per thousand in 10,000 lots, 59c. in 100,000 lots.

NEEDLE CUPS—\$17.50 per M. \$16.00 per M in 5,000 lots. Covers, \$7.50 per M.

COVER STAYS—No. 1, for Table Cabinets, 6 in. long, 9c. each, 100 lot, 7 $\frac{1}{2}$ c. each; No. 2, for Floor Cabinets, 9 in. long, 17c. each, 100 lot, 13c. each; No. 3, heavy for Floor Cabinets, 10 in. long, 20c. each, 100 lot, 16c. each.

Continuous Piano Hinges, 28c. per foot; 100 feet, 21c. per foot.

We also manufacture special machine parts, such as worm gears, stampings, or any screw machine parts for motor; reproducer and part manufacturers.

Special quotations given to quantity buyers in Canada and other export points.

Write for our 84-page catalog, the only one of its kind in America, illustrating 33 different styles of talking machines and over 500 different phonographic parts, also gives description of our efficient Repair Department.

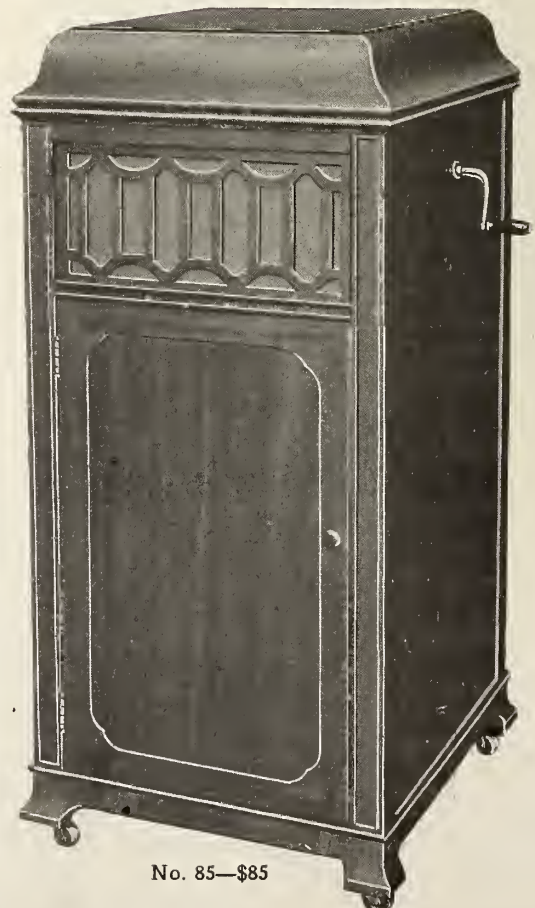

No. 85—\$85

Lucky 13 Phonograph Co., 3 East 12th St., New York

Put the first of the new model Grafonolas on exhibition—advertise their arrival—they are real *events* in the phonograph trade. Your customers will be interested.

Columbia Graphophone Co.
NEW YORK



NOVELTY IN RECORD ADVERTISING

(Continued from page 11)

men of the industry can exercise no control. Another house which has shown individuality in presenting the new songs and records through its clientele, through the medium of bi-weekly newspaper advertisements, is the

**SCHMIDT'S
FUNNIGRAPHS**

Being a series of advertisements appearing each Tuesday and Thursday, in which are used, as headlines, the titles of new songs. To us, some of these are peculiarly humorous, while others bear a life-long sentiment.

Number 4

**"Keep the Home Fires
Burning 'till the Boys
Come Home."**

made by
IVOR NOVELLO
words by
LENA OULSHENY FORD

This is not merely a song but a message of performance in our every day lives, demonstrating our allegiance to Our Country, Our Home, and most of all to "the boys over there."

If you haven't this song in your home, in some one of its forms, you should have.

Number 7
will appear
Tuesday
Page 3

SCHMIDT MUSIC CO.
RELIABILITY IS THE FOUNDATION OF OUR BUSINESS

111-113 W. 3rd St. Davenport, Ia.

Another Clever Schmidt Record Ad

Schmidt Music Co., of Davenport, Ia. A pair of the company's advertisements typical of the series are reproduced herewith. The people of Davenport look for these Schmidt Co. announcements and besides getting a good laugh occasionally out of the song titles and descriptive matter, learn on what records and music rolls they have been reproduced and are thereby moved to make purchases.

AN EDUCATIONAL CAMPAIGN

The Vallorbes Jewel Co., of Lancaster, Pa., are giving attention to an educational campaign in the trade to prove their claims that their semi-permanent needles do not wear away the records. Attractive circulars have been mailed describing the parallel shape of the Vallorbes needle points and showing how they wear down evenly and do not enlarge their diameter towards the end of the record which they claim the ordinary "one-time" needle does. Greatly enlarged photographs of the ordinary steel needle and the Vallorbes needle after a number of playings have been made. The comparison in the wear of the two needles is interesting to note.

The T. P. Pattison Music Co., of Denver, Colo., have added the Brunswick and Bush & Lane phonographs to the talking machines which they handle. Their full line now consists of the Victor, Bush & Lane, Brunswick and Stradivara.

THE MACY-VICTOR LITIGATION

Federal Court Sustains Demurrer to Answer Filed in This Suit

The latest development in the suit of R. H. Macy & Co., against the Victor Talking Machine Co. and its agents for triple damages amounting to \$570,000 for alleged violation of the Sherman Law, by seeking to limit the supply and fix the prices of its talking machines and records, occurred in the Federal Courts on July 22. In its answer to the suit the Victor Co. asked that the action be dismissed because the Clayton Act, which it is alleged was also violated, was unconstitutional by reason of exceptions in favor of horticultural, agricultural and labor organizations, and that the provisions of the law said to be violated could not become effective until after the Federal Trade Commission had exercised its jurisdiction.

The plaintiff demurred to the answer, and Federal Judge Knox sustained the demurrer in a long opinion, in which he said that the Federal Trade Commission only served as an instrumentality for doing justice to business where the remedy could not be applied by the courts.

INCREASES CAPITALIZATION

The Doehler Die Casting Co., of Brooklyn, N. Y., have certified to an increase of capital from \$500,000 to \$1,000,000.

CONGRATULATIONS FOR L. M. COLE

L. M. Cole, traveling representative for the Gibson-Snow Co., Syracuse, N. Y., Sonora distributors, and one of the most popular members of the traveling fraternity up-State, recently returned from his vacation, which gave him an opportunity of recuperating from the activities



Mr. and Mrs. L. M. Cole

of the past year. Incidentally, Mr. Cole's vacation was also a honeymoon, and he has been receiving the hearty congratulations of his associates and friends upon his departure from bachelorhood. Mr. and Mrs. Cole will reside in Syracuse, and, needless to say, one of the most important pieces of furniture in their home is a handsome Sonora phonograph.

The Stauffer Grafonola Shop recently incorporated in Harrisburg, Pa., with a capital of \$50,000, reports an excellent business.

THIS ALBUM MADE US FAMOUS
by selling it. Why don't you try?

Pat. Dec. 15, 1914.

Buy Your Albums Direct From the Manufacturer

THE BOSTON BOOK CO., Inc.
The only exclusive Record Album Factory in the world.

43-51 W. Fourth St. New York, N. Y. Chicago Office: 1470 So. Michigan Ave.



*Make A
Drive
for
Increased
Record
Sales
With
"B and H"
Fibre Needles
as
Your
Strong Ally!*



Mr. Dealer

Push the Sale
of

"B & H" Fibre Needles

For A Revival

In Your Record Sales!

Take our word for it now and your customer's pleased admission later that the tonal qualities of the only Fibre Needle licensed for sale in the United States and their absolute freedom from the scratching sound, which so often mars reproduction, caused such pleasure and satisfaction as to create the desire for new selections.



*Go Over the
Top In
Record Sales
by
Advocating
The Use of
"B and H"
Fibre Needles.
You'll Note
A Renewed
Inquiry
For Records!*



By Such a Campaign, You and Your Customers are Sure to Gain

DELAY DOESN'T PAY!

"B & H" Fibre Manufacturing Co.

33-35 West Kinzie Street

::

::

::

::

Chicago

Why the Accessory End of the Talking Machine Business Should Be Developed

By Lester E. Noble
R. Wurlitzer Co., Chicago

Manufacturing conditions in 1918 have presented a very definite problem to all talking machine retailers, depending largely on the profits accruing from their talking machine sales for the support and carrying on of their business. In previous years it has been possible for each retailer to secure a sufficient amount of machines and records to prevent actual loss of sales, provided the necessary forethought and judgment were exercised in purchasing. This year retailers have found that, due to limited factory output, and regardless of the methods used, it has been seemingly impossible for them to secure more than a set amount of machines and records, and hundreds of them have accepted the situation, assuming that their total business and profits must necessarily be limited.

Certain retailers have refused to accept the situation as it stands, determined to invent some means whereby their sales organization might be kept busy and their gross sales and profits kept at normal. Probably the most successful means used, and particularly one that does not interfere with the progress of their talking machine business nor reduce their standing with concerns

from whom they buy and on whom they are to some extent dependent for merchandise, has been the pushing of talking machine accessories. It is a known fact that the average talking machine dealer has never been obliged to put the maximum effort behind his sales, principally due to the fact that people have had the desire to own a talking machine and records instilled into them from other sources, and, therefore, the selling of talking machines and records has been largely a matter of inducing a customer to purchase one brand over another, and of placing the size instrument and the grade of records best suited to each customer's needs and resources. Now, however, this class of retailers are training their sales organization to create in their customers the desire for certain talking machine appliances of proven worth, which represent in value their retail price and on which a fair profit can be made.

There are two most excellent results of this effort that is being put forth. In the first place, each machine customer and record customer is kept "alive" by solicitation for the talking machine accessories, and each account is made to

show a tidy profit, aside from that gained by the sale of the original machine and the subsequent record sales. Certain retailers during the past six months have made each machine purchaser on their books pay as high as 5 or 6 per cent. in profit on the initial machine purchase, aside from record sales.

Another and without doubt a far greater result is the fact that the sales staffs of the talking machine establishments are being taught REAL SALESMANSHIP, the first principle of which is without doubt to create in the mind of the prospective purchaser a desire for the article to be sold. It is not impossible that this ability to create desire may be highly advantageous, and likely absolutely necessary in the future selling of talking machines and records, and in raising the standard of salesmanship in their organizations talking machine retailers are adding an attribute that has been sadly wanting in the past.

The retailer who does not go after the accessory end of his business at this time can be likened to the colored gentleman of the South who refused to earn a quarter for carrying a suit-case because he already had a quarter.

TALKS ON MUSICAL HISTORY

Miss Edith Rhetts, of the Victor Educational Department, Makes an Interesting Address at the Billings Library, Burlington, Vt.

BURLINGTON, Vt., July 30.—One of the most interesting events in musical circles here recently was the talk given by Miss Edith Rhetts, of the educational department of the Victor Talking Machine Co., Camden, N. J., at the Billings library, before the members of the summer school. She discussed musical history in a colloquial way, illustrating her remarks, both on the piano and by the use of Victor records, which were a tremendous help in displaying the music, which she referred to so admirably in her address. Miss Rhetts went away back to the beginning of music, illustrating her description of Indian music with the "Gambler's Song" and the "White Dog Song." She spoke particularly of the rhythm of this music. She said that music had three vital elements and that people went through those three stages in appreciation: First, they liked rhythm, next melody and next harmony.

As an example of the very oldest music she played some Chinese melodies, and then to show the difference played some from the music of Japan. She illustrated the quarter tone intervals in the Arabian music with another record.

Her next selection was the Grecian "Hymn to Apollo" and before playing it she explained that the present-day music comes from the Greek. She said the Greeks used the lyre and that one could trace the stage of civilization of peoples by the predominance of stringed instruments over percussion instruments.

Miss Rhetts told of the introduction of music into the church, playing a Gregorian mass, and then told how it changed as time went on. She played later masses to show the difference. She played the troubadour song, saying that was an outgrowth of music brought back by crusaders.

She described how the operas came to be written. There was very little orchestra in those days so the singer was lord and master of all he surveyed. As an illustration of operatic music she gave a record of Mme. Galli-Curci.

As an illustration of expressive music Miss Rhetts played "Symphonic Poem" and a modern brass band in Saint-Saens' "Death Dance."

Miss Rhetts during her visit also talked to the teachers of the summer school during the assembly period of the method of and material for teaching appreciation in the grades from the kindergarten to the eighth grade.

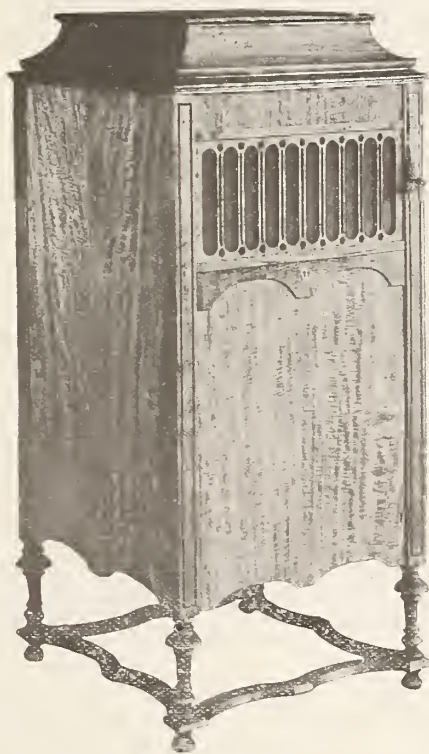

William
and
Mary
Period
Model

Delpheon
the
Incomparable

☞ A truly unusual instrument for those not content with the ordinary

THE DELPHEON COMPANY
BAY CITY :: :: MICHIGAN

Or Write to Distributors

Columbia

Announcing

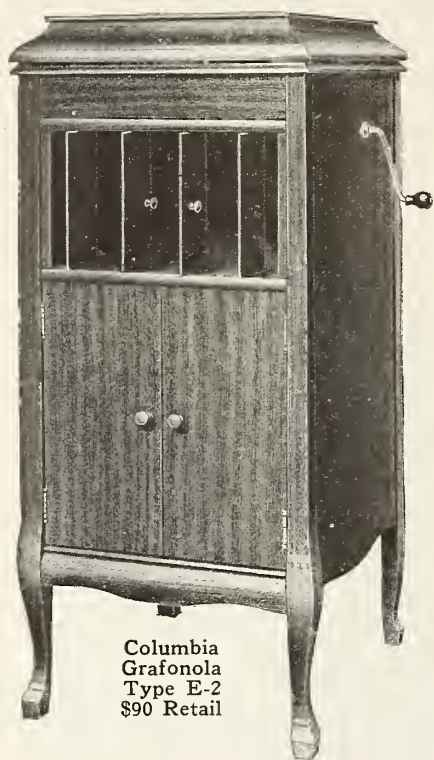

Columbia
Grafonola
Type E-2
\$90 Retail



Columbia
Grafonola
Type G-2
\$115 Retail



New Style Cabinet—New Type Motor—

Here They Are:

The kind of instruments you have wanted to sell ever since you have been in business—instruments you can offer your customers with the absolute conviction that you have the best product on the market.

The *new* Grafonolas! New in design; new in mechanism; new in the marvelous perfection of tone-quality; new in ways that make them bigger, better sellers; greater profit-makers for you.

The New Motor Unit

Strong, compact, portable—with many improvements that make for noiselessness, smooth running,

long life. The plate is hinged, permitting instantaneous changing of motors. Motors can be interchanged by simply loosening two thumb-screws. New Integral Motor Frame; Spring Barrel fitted with bayonet joint.

Columbia Non-Set Automatic Stop

The new Columbia Automatic Stop requires no setting or any attention whatever when playing a record. Start the motor in the regular way by moving the start-lever. The automatic device will stop the motor when the record is through playing, no matter what size record it may be. This does

Sell Foreign Language Records

Small Investment—quick turnover

For Information write to

International Record Dept.

Columbia Graphophone Co.

102 West 38th Street, New York

Grafonola

New Models—



Columbia
Grafonola
Type K-2
\$175 Retail



Columbia
Grafonola
Type L-2
\$225 Retail

Exclusive New Columbia Non-Set Stop

not in any way interfere with moving the start-and-stop lever by hand.

No adjustment is necessary when playing different size records, because the lever that stops the motor is connected with the tone-arm. While a record is playing it holds back the Automatic Stop until the entire record is played. At this point the tone-arm loses its power and the stop occurs infallibly.

The New Columbia Tone-Arm

The slender, symmetrical tone-arm of the Columbia Grafonola is a mechanical attainment of light-

ness, durability and sound-transmission of the highest degree of excellence.

Every tone-arm is tested by playing at the factory, at the same time its attached reproducer is put to critical trial.

It is impossible to describe these new instruments fully here. To really appreciate them, you must see them, and inspect yourself the many wonderful improvements which have been made. Among these are the new tone-arm and the perfected reproducer, advances in phonograph construction almost as important, certainly as valuable to you, as the Non-Set Stop.

Columbia Graphophone Co., New York, N. Y.

EDISONS ON EVERY TRANSPORT

Large Shipment to Hoboken Recently—Transports Will Be Kept Supplied With Velvet Surface Records Through Dealers' Generosity

This photograph was taken at the Edison laboratories, Orange, N. J., as a large shipment of Edison Army and Navy phonographs was being loaded onto trucks to be taken across

of Thomas A. Edison, Inc., was a guest aboard a United States transport and came away with a very keen realization of the need for phonographs on the big troop ships that carry our soldiers to France. A special fund to provide Army and Navy phonographs for the Transport Service was immediately started. A considerable amount was raised in various ways and finally, at the Edison dealers' convention, about \$8,000 additional was contributed by the Edison

SONORA ENJOINS "LONORA"

Suit Brought by Sonora Phonograph Co. Upheld by Supreme Court

A decision was handed down recently in the Supreme Court by Justice Ottinger, restraining the Stefanograph Co., New York, from using the word "Lonora" on their phonograph. This motion was brought by the Sonora Phonograph Sales Co., and the opinion of the court, which is very important and far-reaching, reads:

"This is a motion to restrain defendants, pendente lite, from using the word 'Lonora' upon phonographs to the injury of the plaintiff, who manufactures and markets phonographs under the name 'Sonora,' for which it has acquired a trade-mark, and which has been in use for many years. The principles regulating injunctive relief in cases of this kind, not only for the protection of the plaintiff, but in order that the public may not be deceived, are so well settled that it is unnecessary to review the authorities. There is no question in my mind from the papers presented upon this motion that the defendants are using the name 'Lonora,' and that their purpose in so doing is to deceive and defraud the public into the belief that the articles are those manufactured by the plaintiff. The similarity in names is so evident as not to require comment, and the proof is clear that it was adopted for the purpose of taking advantage of the trade name and reputation that plaintiff had acquired. The defendants do not even undertake to show how or why, out of the myriad words of the language, they selected upon an artificial word identical with, except for the first letter, that used by the plaintiff, and similar in sound. That there may, as claimed by defendants, be some slight differences in appearance and manufacture is quite immaterial if, because of the name, the public are likely to be deceived to the prejudice of the plaintiff's rights. Motion is granted."

Schechter & Lotsch appeared for the Sonora Phonograph Sales Co. as attorneys in behalf of this motion.



Army and Navy Edison Phonographs Being Shipped for the U. S. Transport Service

the Jersey meadows and delivered to the United States Transport Service at Hoboken, N. J.

The two men observing the loading operations are Charles Edison and William Maxwell. The Edison Army and Navy phonograph is one of Charles Edison's hobbies. It is specially designed for use by soldiers and sailors and is sold at a price considerably below its cost of manufacture. Thousands of these instruments have been purchased by patriotic persons and donated to various units of the army and navy. Some time ago Mr. Maxwell, vice-president

phonograph dealers and jobbers in a patriotic response to the need of our soldiers for musical entertainment aboard the crowded transports that carry them on the last leg of their journey to France. This liberal contribution on the part of the jobbers and dealers brought the total to an amount which not only provides a full equipment of Edison Army and Navy phonographs for all of the United States transports, but also sets up a fund from which the transports can be regularly supplied with Edison Velvet Surface Re-Creations for a long time.

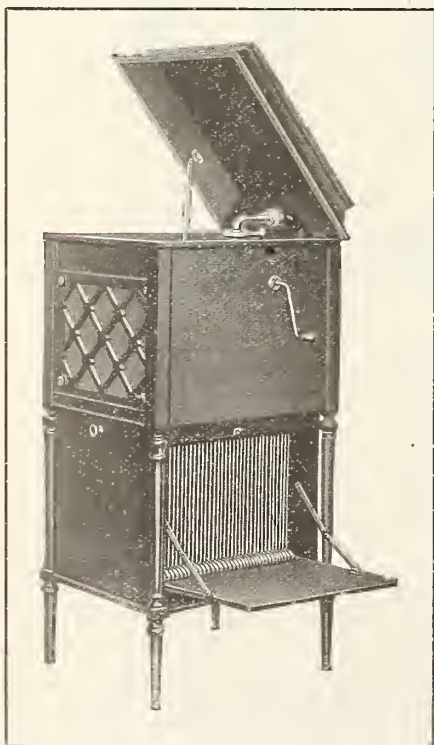

THIS is the Edison style A100, equipped with an EJECT-O-FILE. Note the beauty, as well as the simplified efficiency, in filing and finding records at will.

Please send Price List and Cuts of other Styles.

Name.....
Street.....
Town.....

The Eject-O-File Sales Co.
216 W. Saratoga Street
BALTIMORE, MD.

How Complaints Can Be Made a Business Asset and Used As a Basis for Future Sales :: By J. A. Parsons

Welcome complaints. Encourage your customers to come into the store and tell you or your salesmen about their troubles or fancied troubles with any of the goods you have sold, for a complaint is just as important as a sale, and, perhaps, more so, and should receive equal attention. A complaint, no matter how trivial, that is properly handled, can be turned into a genuine business asset, and a complaint neglected, or not given sufficient attention to satisfy the customer, can offset the good effects of several weeks of sales work.

The talking machine dealer, or his manager or salesman, who takes the stand that his line of talking machines or records can give no just cause for complaint is too narrow-minded to remain in business. The talking machine is simply the product of human hands, and workmen are always liable to make errors, no matter how skilful or careful. Then, too, there are may be unseen flaws in materials or in adjustments that first become apparent in the home of the customer. No matter how high the price or reputation of the instrument, there will always be occasions, few perhaps, when the purchaser finds some real or fancied reason for complaint, and when the complaint is filed it should be investigated courteously and honestly for the protection of the dealer's name.

A purchaser who has complained about some particular feature of the instrument must have some reason for bringing the matter to the attention of the dealer. If the customer is laboring under a delusion, then his or her mind can readily be set at rest with a proper and courteous explanation, and the customer will return home feeling that the talking machine man is desirous of dealing fair and remedying any possible er-

rors. If there is some actual reason for the complaint, the sooner the instrument is adjusted, just so much sooner will the instrument be in proper shape to be a fitting advertisement for the dealer's line among the friends of the purchaser.

If the purchaser comes into the store, or phones or writes in, as the case may be, and is then snubbed or receives scant attention, then the opportunity of making a lifelong friend for

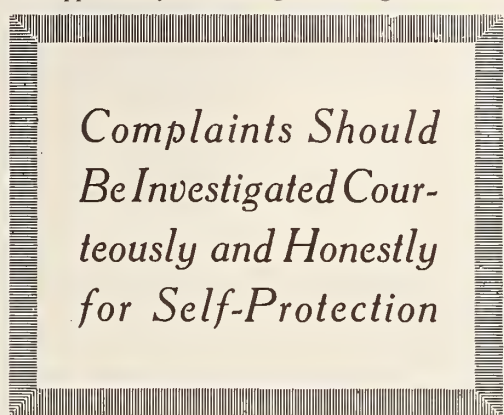

Complaints Should Be Investigated Courteously and Honestly for Self-Protection

the house is lost and, particularly if the customer is a woman, there will be no opportunity lost to tell of the treatment she received when she complained and the cause of the complaint will be pointed out with great earnestness as a warning to all friends to beware of buying at that particular store or of purchasing that particular kind of machine and suffering a similar annoying experience.

If the manager of the store appears callous to complaints, the salesman should himself see to it

that the customer is fully satisfied with the purchase, and encourage the reporting of anything that appears to be wrong. The salesman's biggest asset is the list of prospects he is able to compile through the friendliness of satisfied customers, who generally take pride in recommending their particular make of machine and the house that sells it to their friends.

Simply to follow up the complaints of instalment customers with a view to keeping them satisfied until all payments have been made and then neglecting the cash customer because there is nothing due on his instrument is a mistaken idea that, apparently, prevails in many talking machine houses even to-day, regardless of the fact that the cash customer is probably possessed of the greater number of influential and well-to-do friends who may become prospects.

Watch the complaints. They can be developed into sales later on.

MANAGERIAL CHANGE IN HOUSTON

HOUSTON, TEX., August 1.—W. B. White, who was formerly manager of the wholesale department of Thomas Goggan & Bro., of this city, is no longer with that institution. He has become manager of the talking machine department of the Schaeffer Photo Supply Co., who are handling the Columbia Grafonola exclusively. This concern have been in the talking machine business only a couple of months, but in that time they have done a very large volume of trade, due in a large measure to the character of the advertising they have indulged in, as well as the line which they handle.

It is impossible to wrong another without injuring yourself.

LONG CABINETS



No. 83

In all finishes. Specially adapted for use with Columbia 50. Front posts made to follow lines of posts on Columbia 75.

FIRST and FOREMOST

In the cabinet field.

Why? Because we've *specialized* in

**CONSTRUCTION
FINISH and
ADAPTABILITY**

Our supremacy in these essentials warrants your handling *the perfect line.*

That's why you should anticipate your wants **NOW.**



No. 79

In all finishes. Shown with top moulding and shelves. Specially adapted for use with Victrola IX-A.

Prompt deliveries on all orders. Write for Illustrated Catalogue of complete line

**THE GEO. A. LONG CABINET COMPANY
HANOVER, PA.**

We Offer An Unusual Proposition To Dealers

It doesn't matter what make of phonograph you are now handling, you owe it to yourself to investigate what we have to offer you.

We have developed a great talking machine co-operative plan—one that enables the aggressive dealer to make big money on quality talking machines.

We are staking our money and our reputation on this proposition to establish successful talking machine dealers in every community.

In this advertisement we illustrate Model No. 3—our big seller. It is stately in design, wonderful in tone, and is sold under our guaranteed service. It sells for \$125.00, and unquestionably represents greater value than was ever offered at this price.

This machine is one of the big factors in our co-operative selling plan.

Two additional models—Model No. 6 at \$90.00, and Model No. 5 at \$65.00, give the MANDEL dealer three popular priced machines, all of which embody high quality coupled with big value to the consumer.

What we offer you, Mr. Dealer, is liberal terms, liberal discounts, big profits, and our guarantee of absolute satisfaction to every ultimate purchaser of a MANDEL Phonograph.

Act quickly. Write for our complete proposition. We are closing up territory at record speed.

Mandel Manufacturing Company

General Offices:
501-511 So. Laflin Street
CHICAGO, ILLINOIS

New York Display Rooms:
41 Union Square
NEW YORK CITY, N. Y.

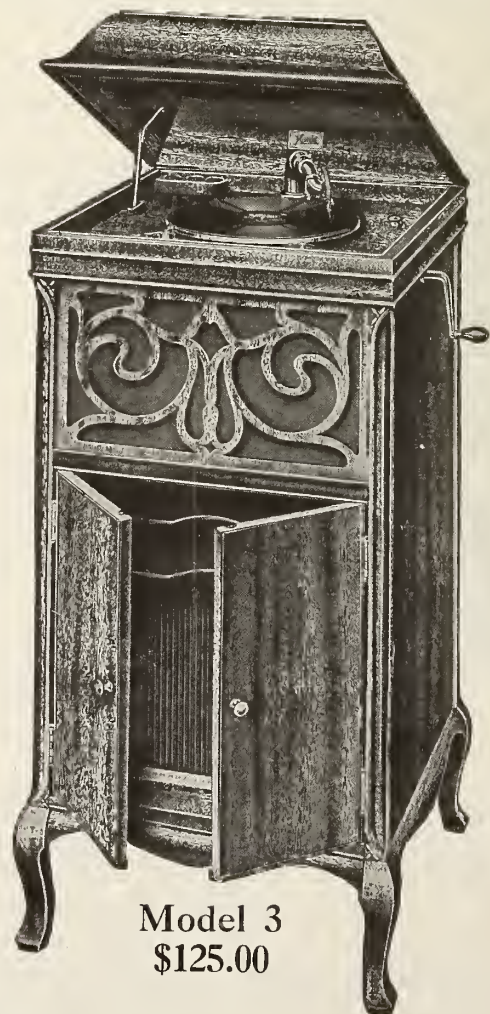

Model 3
\$125.00

Artistic Window Displays That Arouse Public Interest in Talking Machines and Records

Talking machine dealers are evidently becoming more keenly alive than ever before to the value of window display as a factor of importance in their business. They are realizing that the well-dressed window, the often-changed

Detroit. This window, which deservedly attracted a great deal of attention, was admirably conceived. Patriotic records were the principal feature of display, and these were surrounded with miniature soldiers, small tanks and other little displays, such as soldiers' hats with red, white and blue base, which, admirably arranged around the window, made a very attractive display.

In the line of summer display windows that prepared by Lyon & Healy, of Chicago, illustrated on this page, is not only most artistically conceived,

still keep well in touch with all that is latest and best in music.

We have often emphasized in these columns the value of the window as a business developer. It must always be kept in mind that at a comparatively small expense it can be made one of the most profitable features of a store. It can be made to reflect the enterprise of the owner. It conveys to the passers-by and to the people in the town that the owner of the window is a man of initiative, a man of artistic impulses, a man who desires to do things. The general public likes to deal with such an establishment, hence the value of the window as an advertising medium.

The merchant who utilizes the changing seasons and current happenings, particularly in helping the various departments of the Government in these war days, is devoting his window space to good purpose. It really matters



A Summer Window of Lyon & Healy, Chicago

window, is a silent salesman that pays a good return for the time and money spent in using this space advantageously. During the past month The World has received a large number of photographs, showing that dealers are giving the closest attention to window displays. They are giving considerable space to stimulating patriotic endeavor, as well as utilizing the summer season as a means of bringing to the notice of prospective buyers that the talking machine is an indispensable equipment during the vacation period, and that no summer home can well afford to be without it.

In the line of patriotic windows we are reproducing a very attractively arranged display made by the talking machine department of the People's Outfitting Co., 44-48 Michigan avenue,

but it represents a great deal of expense and time in its preparation. No one can look upon this window without having a desire to get away from the noise and confusion and worries of city life—to live in the open, in the woods, enjoying fishing and sports of all kinds accompanied by the ever faithful and always reliable talking machine to supply the music and comfort and necessary "atmosphere." Thus the Lyon & Healy window fulfilled a mission. It pointed out that one can rough it to-day and

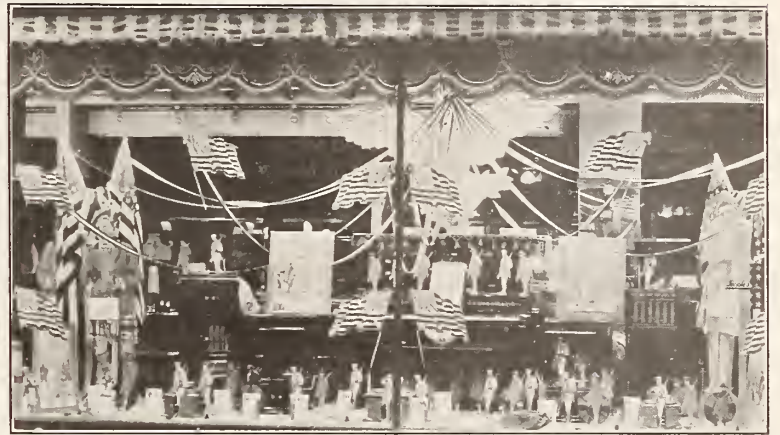

Patriotic Window of the People's Outfitting Co., Detroit

little what window space a dealer may control, if he makes the most effective display possible in the space at his disposal he will have done his duty and proclaimed himself to be a progressive and up-to-date talking machine merchant.

A VERY PERTINENT IDEA HERE

Which Some Types of Salesmen Should Consider and Properly Digest

Here is an incident which came under our notice recently which furnishes the point to an idea which should be considered by dealers.

The following conversation was recently overheard in the shop of (we are prone to believe an unsuccessful) Columbia dealer.

A gentleman came in, walked up to a clerk and said: "Have you A-2158?"

The clerk answered promptly, "No, sir, we have not. Anything else?"

To which the man replied, "I guess not," and went out.

By a strange coincidence we were in the shop of another Columbia dealer in the same town later in the day, when the same man entered and asked for the same record.

The salesman said, "I'll see at once, and while I am looking it up I would like you to hear this one," putting on A-2450, starting the instrument and stepping back to look up the record asked for. In a few moments he returned and said, "I am sorry, but we are out of the number you want."

To this the man replied, "Let me have this one you are now playing, and order the other for me."

We have nothing more to say. Have you?—The Peptimist.

The Polyphone Talking Machine Co., 3602 Park avenue, New York, has changed its name to the "B and B Talking Machine Co."

NEW IDEA IN RECORD INDEXING

HARRISBURG, PA., July 31.—The Harrisburg Book Co., of this city, have placed recently upon the market an entirely new idea in record indexing known as the "Handy Record Index." It is a conveniently indexed book in which may be listed for ready reference the records, vocal, instrumental, etc., etc. The idea was originated by George H. Dunham, head of the company, in keeping his personal records handily indexed. The system worked so well that he decided to commercialize his idea. It should make a strong appeal to record users.

THE VICTOR AT DRAKE UNIVERSITY

DES MOINES, IA., August 5.—Mrs. Heaton, of the educational department of the Victor Talking Machine Co., while passing through this city recently on her way home from a vacation, stopped long enough to give several valuable demonstrations of the Victrola in educational work at the Drake University here. She also took occasion to call upon Mickel Bros., local Victor wholesalers.

GLADVERTISING VS. SADVERTISING

A talk by Arnold Joerns, of Chicago, on "Gladvertising vs. Sadvertising" was the feature of the closing session of the Indiana Sellers' Congress recently held in Indianapolis. The seven motives of human nature, which always should be kept in mind in advertising and selling, he said, were property, self-preservation, power, reputation, affections, sentiment and taste. The question of the cost of an article, he continued, concerned a customer's property motive. In his opinion, the speaker said, too much attention often is paid by merchants to advertising the price, while too little stress is laid on the merit or quality of the goods.

Mr. Joerns also scored the merchant who advertises selling below cost, when it is impossible, on the face of the proposition, for a man to continue in business while selling his goods below the cost. In closing he said that no phase of human nature should be overlooked in advertising.

Fred N. Van Wic, of Oneonta, N. Y., is building up a good talking machine trade.

Talking Machine Hardware

We manufacture hardware for all styles of cabinets

Lid Supports
Needle Cups
Needle Rests

Door Catches
Sliding Casters
Continuous Hinges

Sockets
Tone Rods
Knobs, etc.

BEST QUALITY

LOWEST PRICES

WEBER-KNAPP COMPANY

Jamestown, N. Y.

NEW OFFICERS FOR DUO-TONE CO.

Prominent Business Men Now at Head of That Organization—Featuring New Stylus

ANSONIA, CONN., July 31.—The Duo-Tone Co., of this city, have recently elected new officers. They are as follows: President, Frank D. Terry; vice-president, C. S. Anschutz; secretary, Carleton F. Hoadley; treasurer, Chapple S. Carter. The new officers are all prominent men in this locality and are all new with the exception of Mr. Carter, who retained his office as treasurer of the company. L. P. Cornet, who is well known to the talking machine trade and who has been connected with the organization for some time, has been appointed as general sales manager of the company.

In addition to the Duo-Tone device they are now featuring the De Luxe stylus. Although they have had this new semi-permanent needle for some time they are now behind a campaign to make it known from coast to coast. They report good business and that several large jobbers have already taken on their new product and are enthusiastic over it.

FACTORS IN THE RETAIL FIELD

In the retail talking machine field the druggists seem to be figuring to a much larger extent than ever before throughout the country. The drug store is usually a center for the people of the town, or district, and talking machines and records are apt to find in these establishments a large following. At the present time there is a large army of druggists throughout the country who have taken on talking machines, and find them to be perhaps the most profitable end of their business—at least they return a very nice income on the space devoted to these instruments.

SIZING CARUSO UP

Enrico Caruso, who is soon to bust right out as a film hero, went to the Famous Players-Lasky studio the other day to have a look at things. A property man asked a camera operator who "the stocky little guy" was.

"That's Caruso, the tenor. He's going to be a film star," came the reply. The property man studied Caruso a moment and muttered: "He's a great tenor singer, all right."

Incidentally, Carolina White, grand opera star, is to make her film debut playing "opposite" Caruso in his first picture.

JOE KERR DOING "HIS BIT"

Former Representative of S. B. Davega Co. Destined to Distinguish Himself at the Front—Well Known to the New York Trade

We take pleasure in presenting this month a photograph of Joseph Kerr, who before joining the colors represented the S. B. Davega Co., Victor distributors, in New York and adjacent territory. If Mr. Kerr serves Uncle Sam—and we certainly know he will—as well as he served the interests of his multitude of



Joseph Kerr

Victor dealers in the territory which he controlled, we feel sure that he will quickly rise in the ranks, and if given the opportunity, distinguish himself, thus bringing honor on the industry, on his native city and on the nation.

FEATURING THE NEW EDISON

The Lair Co., Charleston, Mo., is carrying on an extensive campaign in that section in the interests of the New Edison. The company is advertising extensively in newspapers and through the medium of folders and sales promotion letters, and is getting excellent results in a business way.

"I AM NOT QUITE READY YET"

Under the Above Title R. Montalvo, New Brunswick, N. J., Read the Following Interesting Paper at the Recent Edison Convention

Of all the excuses given to salesmen by prospects, I think the one, "I am not quite ready yet," is probably the most camouflaged stall of all others.

Back of this the real reason may be that they are not quite convinced that the New Edison is the best or that they have not enough money; or it may be the terms are not suitable or that they wish to consult with their wives or husbands or other relatives before buying.

A salesman should never be looking for a negative attitude from his customer, or at least he should be clever enough to avoid letting the customer see that he has recognized such an attitude. There are times when it is advisable for a salesman to appear dense, and when a prospect says he is quite ready to buy, the salesman should assume that the customer has fully decided to buy a New Edison. If he doesn't know which model, he should find out immediately and arrange for delivery at a time desired. When the terms have been decided on and the sale written up, it should be an easy matter to secure the signature on the dotted line. In fact, from the time the customer says he is not quite ready yet, a salesman should proceed exactly as though the sale was made—this will either land the sale or bring out another stall.

A salesman may know to his own satisfaction that the sale has not really been closed and that he is trying to land the prospect before he has really made up his mind, but at the same time the salesman should tell the customer how well pleased he will be with his New Edison and that he will never regret having purchased the "Phonograph with a Soul."

Other legitimate reasons that may be advanced by the salesman to the prospect as to why he should buy now are the shortage of goods and the fact that there will probably be another increase in price shortly.

TALKING MACHINES FOR EXPORT

South Americans Sending in Large Orders for Talking Machines, According to Head of Large Export House in New York City

Local exporters with connections in South American markets are constantly receiving inquiries for talking machines made in this country, says the New York Times. The lines sought range all the way from the cheapest grades, made to retail at \$5 or less, up to those bringing as much as \$300. Machines priced from \$50 to \$100 are sought in the largest quantities. According to the head of one big export house, American talking machines have established themselves permanently in the various markets along the East Coast of South America. There is very little likelihood of the business in these sections reverting, he asserts, to its original source of supply—Germany, after the war is over.

SON OF EDISON IN TANK CORPS

William L. Edison Joins Section of U. S. Army That "Treats 'Em Rough"

William Leslie Edison, second son of Thomas A. Edison, president of Thomas A. Edison, Inc., enlisted last month in the Tank Corps of the United States Army, and left at once for Fort Slocum, to begin training. William Edison is a veteran of the Spanish-American war, and made his home in Morristown, N. J. He stands high in the electrical world, and decided he wanted to see action in the Tank Corps.

A certificate of incorporation was issued recently to the Smith Phonograph Corp., of the Bronx. The active capital of the new concern is \$32,500, the incorporators being C. W. Cartier, W. Heines and M. Sloane.

Ward's Khaki Moving Covers



PROTECT YOUR MACHINES FROM ALL KINDS OF WEATHER

and will enable you to deliver them free from dust, scratches, bruises and all other finish destroyers

Our covers are faced with Standard Khaki, lined with a heavy grade flannel, interlined with an exceptionally good grade of heavy cotton or felt, diagonally and closely quilted, and manufactured according to the usual superior "WARD New London" quality.

Grade "D", medium size, \$6.00
Grade "D", large size, \$6.50
Grade "K", medium size, \$8.00
Grade "K", large size, \$9.00

Carrying Straps: No. 1 \$1.00; No. 2 \$2.00; No. 3 \$3.50

ORDER SAMPLE COVER ON APPROVAL

With Name of Machine silk embroidered on any Cover; extra, 30c.
With Dealer's Name and Address, first Cover; extra, \$1.15
Same on additional Covers, each extra, 60c.

Write for booklet.

THE C. E. WARD CO.

(Well-known Lodge Regalia House)

101 William St., New London, Ohio

Also Manufacturers of Rubberized Covers and Dust Covers for the Wareroom

Grade "D" Cover with No. 3 Straps.



Otto Heineman Phonograph Supply Co.

INCORPORATED

25 WEST 45th STREET, NEW YORK

FACTORIES, ELYRIA, O.—NEWARK, N. J.—PUTNAM, CONN.

CHICAGO

ATLANTA

SEATTLE

CINCINNATI

TORONTO



Tone Reproduction

Buy only the highest grade HEINEMAN-MEISSELBACH Tone Arm Combinations.
Your machines will then be unexcelled in tone quality.



HEINEMAN TONE ARM No. 11
HEINEMAN IDEAL SOUND BOX No. 2

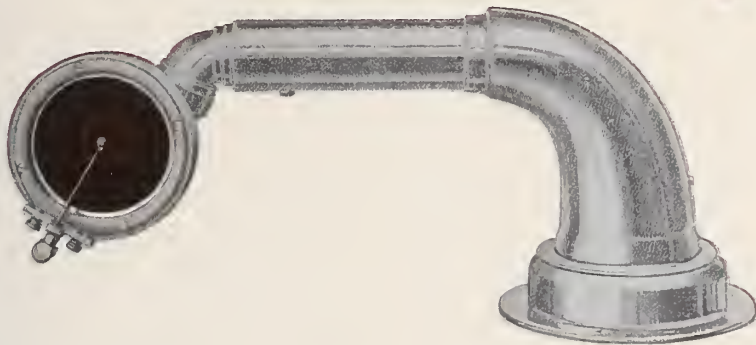

HEINEMAN TONE ARM No. 12
HEINEMAN IDEAL SOUND BOX No. 2



MEISSELBACH TONE ARM No. 97
MEISSELBACH No. 2-C SOUND BOX



MEISSELBACH TONE ARM No. 97
MEISSELBACH No. 2-C SOUND BOX



MEISSELBACH



TONE ARMS

MOTORS

SOUND BOXES

Some of the Advantages of Being a Practical Talking Machine Salesman

By Don Warner

How much knowledge should a salesman possess in order to make a more than ordinary success in the sale of talking machines? Now, selling talking machines might be a simple matter. Presumably it is, and then after the sale is made there might arise the unlooked-for difficulties that are not anticipated when the sale is being made. Your larger knowledge of the instrument itself and your more detailed grasp of the inner workings of the machine can be made a help to you in increasing your sales.

It is so simple to discuss talking machines. They are so widely known and so generally used that it seems everybody knows what they are, and there does not appear to be any very great reason why the salesman should give much of his time to the more intricate parts of the device. So some of them think. But now let us go into this matter a little and then see if there is not some value to be placed on the larger knowledge that can be had with that careful inspection and study of the art or the mechanism of the wonders that are made possible with this device.

What do we know about the sound box and about the unseen factors that enter into the wonders of this device? Can we explain to the customer just a little of the secrets that make possible this tone transmission? Can the salesman give a fair explanation of why the sound is carried from the arm of the machine, from the diaphragm into the reproducer and then to the sound box? Is it necessary to be able to explain this to the prospect? Not always of necessity, but certain it is that this knowledge will prove to be a material aid to the salesman.

Suppose that the customer asks questions, as some of them do. When the salesman is at a loss to explain some of the more simple details can he impress the customer favorably? She might want a comparison of the various talking machines. She would like to see where in they differ. If he cannot give a satisfactory explanation then there is danger that there will be a lessened number of sales to his credit. The salesman should be posted. He should be able to make some statements that are of value to the customer and of help to him in increasing the number of his sales.

This is all in the day's work, and it can be made to become of a wonderful help to the man who is going to make it a part of his future betterment. It might not be a very serious matter to him. It might be looked upon as one of the more detailed matters that can be passed by and that will not become so important that it must be given study. There are certainly some points of distinction about every machine. There are features that lend a different tone to the phonograph. There are little details that are worked out by the inventors and the manufacturers that give each machine an individuality that can be made a strong talking point, provided the salesman is aware of these things.

This is one reason for the education of the salesman along practical lines. There are others, of course, and of these let us say a word with regard to the importance of this knowledge. We might say a little mechanical ability or training, too, can be put to excellent advantage when the occasion does arise. Now the out-of-town salesman, or that man who travels about making sales of these machines, oftentimes has need for a larger detailed knowledge of the inner workings of the phonograph. Suppose he arrives at a place where there is a slight defect or a little something that has gone amiss with the phonograph. It might be remedied where this training has been inculcated. It can and will save the cost of a shipment of the machine back to the store, or

the services of a man who must travel to make the adjustment. It is by no means uncommon that such an occurrence would be met with, and the help that the salesman could render would be of great benefit. One trip of the machine back to the store or the saving of one repair man's time to the dealer will pay for this knowledge.

The salesman is not merely a man who can, like a phonograph, give voice to the words that

Ability of Salesman to Explain Hidden Features of Machine to Customer Means Closing More Orders

are repeated there by the records. He must be a man who can induce sales and can offer logical reasons for the purchase of a talking machine with intelligence and with a care and training that should place him above the commonplace salesman. He is not merely a tool that is working without a brain. He is a man who should give the matter of salesmanship study. He should give the details of the machine that he is offering particular consideration. If his machine differs from others, can he intelligently say why this is so? Can he argue with a correct knowledge that will convince the customers that he speaks with authority?

You men who are selling should study the industry and its larger possibilities with that added care that will bring to you a strong reason for success. Do not be content with merely a superficial knowledge that can never amount to anything but a poor measure of success. Make your hours of idleness count for the larger benefits that can be had with a larger grasp on the subject of talking machine technical knowledge. The industry is new, comparatively speaking, in this country. It has great possibilities and these greater possibilities are within the reach of the salesman who is looking beyond to that to-morrow and to the time when every hour will count and every argument that is sane will become to the wideawake man something that is really worth while to him and to his industry as well.

LANDAY 34TH STREET STORE CLOSES

Landay Bros., Victor wholesalers, have announced the closing of their store at 27 West Thirty-fourth street, and this store will be consolidated with the Landay establishment at 23 West Forty-second street. Under this new arrangement Landay Bros. have three exclusive Victor retail establishments in New York City, these stores being located at 563 Fifth avenue, 427 Fifth avenue and 23 West Forty-second street. The general offices of the company are located at 151 West Thirtieth street, New York.

TALKING MACHINE DEALER IN NAVY

L. L. Dunlap, proprietor of the Talking Machine Shop, in Belvidere, Ill., has enrolled as first-class machinist's mate in the Aero Division of the U. S. Navy, and has reported for duty at Pensacola, Fla. The business will be conducted during his absence by his wife, who is an experienced saleswoman.

A Word to the Phonograph Trade

The "BLISS" REPRODUCER with its treated silk diaphragm differs from the ordinary type of mica sound box, offering a latitude in reproduction that is not attained with the mica diaphragm. It reproduces with *greater volume, better articulation*, and represents the artists as they performed.



Better music is being demanded by the public, and with the "BLISS" REPRODUCER you can meet this requirement.

Other Phonograph specialties that we are featuring are the "Disk-Lite", an electric lighting attachment adaptable to any Phonograph, and the "Phono-Lite", an automatic lighting attachment for the New Edison. Also Edison Diamond Points and Edison and Sapphire Points.

Owing to the acute shortage of material and the certainty of price advances, dealers are advised to place their orders at this time to insure delivery for their fall and winter trade.

WRITE US FOR DEALERS' PRICES

WILSON-LAIRD PHONOGRAPH CO., Inc.
Factors and Distributors of the BLISS REPRODUCER
29 West 34th Street NEW YORK CITY

To The Phonograph Men Of America



Service and Price

No matter how perfect the phonograph itself might be, you would have real difficulty in selling it if service was lacking and the price exorbitant.

Wilson service does not end with the sale of the instrument to you. That point is really where our service commences. The entire giant organization of Wilson & Co., with branches in over 150 principal cities, back us up in seeing that you receive prompt delivery, efficient selling helps, co-operative advertising, and all else that goes to make service.

Wilson prices are figured to give a legitimate profit to our dealers. With the buying-power that is ours we can mark our instruments at prices that hold an irresistible appeal to the public.

*There is a Wilsonian
For Every Home*



WE ANNOUNCE six new and improved models of the Thos. E. Wilson & Co. phonograph.

The Wilsonian

Retail from \$35.00 to \$250.00

Dealers and salesmen realize more than ever before the vital importance of *quality* and *individuality* in phonographs.

The Wilsonian has many refinements and individualities of style and construction that will appeal instantly to the most critical buyer.

The Wilsonian renders the most difficult and intricate musical and vocal selections with wonderful clearness and beauty of tone.

The Wilsonian plays all makes of disc records without it being necessary to make annoying changes.

The Wilsonian is shown in six different models, all representative of their class, and each one selling at an extremely moderate price.

The Wilsonian is absolutely guaranteed. Both this firm and our parent organization—Wilson & Co.—vouch for the dependability of **The Wilsonian**.

Dealers who desire to participate in the profits that will be made on **The Wilsonian** this year are invited to write today for full information.

Main Plant
701 North
Sangamon
Street
Chicago



Eastern
Office
25 West
45th Street
New York

WILSON & CO. BRANCHES ARE IN ALL PRINCIPAL CITIES,
INCLUDING

Boston
Philadelphia
Baltimore
Buffalo

Detroit
Rochester
Cleveland
New Orleans

Salt Lake City
Los Angeles
Minneapolis
Denver

Omaha
Dallas
Atlanta
Kansas City

Charleston
Memphis
Spokane
Pittsburgh

You can offer your customers the new model Grafonolas with the absolute conviction that no other machine made today can equal them in mechanical perfection or tone-quality.

**Columbia Graphophone Co.
NEW YORK**



ENTHUSIASTIC OVER THE OUTLOOK

John Cromelin Returns From Western Front and Tells of the Splendid Reception Being Accorded the Heineman "OkeH" Records

John Cromelin, general sales manager of the Otto Heineman Phonograph Supply Co., New York, returned recently from a visit to Chicago and St. Louis, and in a chat with *The World*, commented upon the enthusiastic reception being accorded the Heineman "OkeH" record in all of the Western trade centers. He states that this record is finding a ready market with talk-



John Cromelin

ing machine manufacturers who do not manufacture records but who appreciate the desirability of placing a record line with their dealers.

While on this trip Mr. Cromelin closed arrangements whereby three well-known houses in Chicago will act as distributors for the Heineman "OkeH" record, and also closed a deal with a prominent St. Louis house, which will give this record line a strong representation.

According to present plans, the Heineman "OkeH" record will be merchandised through jobbers exclusively, but the Otto Heineman Co. will institute a campaign to create dealers who will be turned over to the most conveniently located jobber, to whom maximum co-operation will be afforded. While in Chicago Mr. Cromelin made his headquarters at the company's local branch, where he found Manager A. S. Ribolla optimistic to a degree regarding the possibilities for developing "OkeH" record business in his territory.

Paul L. Baerwald, formerly Eastern sales

manager of the Otto Heineman Phonograph Supply Co., is now a member of the Chicago sales staff, assisting Mr. Ribolla in developing the demand for the Heineman products in that part of the country. The sales totals of the Chicago branch have increased tremendously the past year, and Mr. Baerwald will be in a position to render invaluable assistance in handling the Western trade.

TRADE SWINDLER ARRESTED

Man Named Rogers With Confederate "Run Down" by Leading Talking Machine Houses

Talking machine dealers in New York and nearby territory were greatly pleased to learn of the arrest recently of John W. Rogers, who is charged with swindling numerous talking machine dealers in this city. The arrest of Rogers, who has also worked under numerous aliases, was accomplished through the united efforts of C. H. Ditson & Co., John Wanamaker and Bloomingdale's, who succeeded in developing a plan that enabled them to secure the arrest of the swindler.

It is understood that Rogers worked his swindling scheme in company with a confederate. This plan consisted of ordering a talking machine to be sent to an address on Thirty-third street, and giving as a reference a man named Smith. When the store wrote to the name given as reference, Rogers handled all the mail at this "dummy" address, and answered the letters himself. After receiving a satisfactory response from his reference, the store usually shipped the instrument to the address on Thirty-third street, where it was subsequently delivered to another address on Thirty-second street. At this latter address Rogers' confederate secured the machine, and between them sold the instruments around the city. The confederate was also arrested, and both he and Rogers are now awaiting trial.

The Crown Disc Co., of New York City, has increased its capitalization to \$75,000.

VAL REIS TEMPORARY PRESIDENT

Heads Tri-State Victor Dealers' Association, Owing to Retirement of A. M. Magoon—Officers Will Be Elected at Meeting in September

St. Louis, Mo., August 5.—Val Reis, treasurer of the Smith-Reis Piano Co., has been elected temporary president of the Tri-State Victor Dealers' Association, vice A. M. Magoon, who leaves St. Louis to return to his former home in Minneapolis.

The selection of Mr. Reis was announced by the executive board after a meeting held July 30. The election will obtain until the September meeting of the association, the date of which is not yet announced. All officers of the association are regarded as "temporary," as they were elected prior to the membership campaign and are St. Louis men. It is hoped that at the September meeting there will be a big outside representation of members and that officers representative of the scattered membership will then be elected.

The executive board announced that arrangements had been completed for the attendance at the September meeting, which will be regarded as the first annual meeting of the association, of a number of Victor artists and many prominent trade speakers. Both Victor and general trade subjects will be treated by men who know whereof they speak.

O. L. Faster, of the Faster Shops, Lafayette, Ind., was elected a member of the association.

Mr. Magoon, who has been the only president of the association, was manager of the talking machine department of the Kieselhorst Piano Co. for two years. He came here from Minneapolis, to which city he returns as manager of the Victor department of the Dayton Drygoods Co. At the meeting of the executive board of the association a resolution of regret at his departure from the association territory was adopted. He is succeeded at the Kieselhorst Co. by J. B. Sabath, who has been assistant manager since last October. Mr. Sabath came here from the East.

COTTON FLOCKS

.. FOR ..

Record Manufacturing

THE PECKHAM MFG. CO., 238 South Street, NEWARK, N. J.



AUTOMATIC STOPS

The simplest and most efficient Automatic Stop on the market. They give excellent service, are easily installed and are absolutely guaranteed.

Send 50 cents for Sample Stop

KIRKMAN ENGINEERING CORPORATION, 237 Lafayette St., New York

THE TRADE IN PHILADELPHIA AND LOCALITY

PHILADELPHIA, PA., August 8.—There is a general feeling of satisfaction all around as to the conditions in the talking machine field for the month of July. On the whole the business was considerably better in Philadelphia and vicinity during the past month than was the case during a year ago. In the early part of the month there was a boom business on, but the excessive heat that struck the city the last week of the month naturally curtailed business.

Conditions as to the receipt of machines and records form the oft-told story. All orders could only be partially filled, but the percentage was no less than in a number of previous months. There has not been the great variety in records to be had, but there seems to have been an abundance of records of certain classes, and these seemed to satisfy the dealers, and all around it looks as if the trade was going to enter the fall with excellent prospects.

There has not been any news of special interest to the trade in Philadelphia during July. No new dealers have been appointed, and no houses are making any startling changes. Cost of material and labor is so high that there is likely to be very little of this at least for some time to come.

Penn Co. Moving in New Home

The Penn Phonograph Co. are making their final move to their new home on Arch street, and have about completed the establishing of their stock in their new quarters. They expect to move their offices to Arch street by the beginning of next week. Through their arrangements with the owners of both buildings they have been able to take their time as to moving, and they have not been handicapped in any way.

Doing Well With the Pershing Record

The Columbia Graphophone Co. are advertising extensively in this city their record of "General Pershing's Own Voice," and it is having a big sale. They have secured an ample stock of these records to meet all demands, and they expect it to be the biggest seller of the year. Manager Heath, the Columbia distributor here, says: "The record is taking very well. It has immense possibilities. It should sell to every one in the United States, especially to the thousands of families who have men in the service."

TALKING MACHINE DEALERS

can greatly increase their profits without additional overhead expense, by selling the world-famous

Weymann "KEYSTONE STATE" Musical Instruments

a combination that has proved to be an instantaneous success.

Write for catalogue

H. A. WEYMANN & SON

Manufacturers

**Victor
Wholesalers**

**1108 Chestnut St.
Philadelphia, Pa.**

Established 1864

Business Is of Record-Breaking Character

Mr. Heath says that business for the Columbia and its records keeps going at a record-breaking pace. The firm have been handicapped during the month by a number of the Columbia boys going into the service, but they are making the best of things as a part of "doing their bit." Mr. Heath recently made a trip to Harrisburg, York, and other towns in that section, and says that he found things in excellent shape, and that all of the Columbia dealers at this time of the year, when things are generally dull, are reporting that there is a holiday business spirit in the air. They have been fortunate the past week in receiving a few carloads of stock to keep their dealers supplied.

They have not, during the month, received an abundance of machines, but have sufficient to take care of their dealers to a certain extent. Mr. Heath is planning to get away for a short vacation towards the end of the month.

During July the following Columbia representatives visited Philadelphia: F. R. Erisman, manager of the Dallas, Tex., store, and A. W. Roos, manager of the Cleveland branch. They were both here on their vacations.

Activity With Blake & Burkart

Mr. Blake, head of the firm of Blake & Burkart, who is the biggest handler here of the Edison phonograph, says that he has no kick coming at all. Phonographs, records and customers have all been coming through fine. He says: "We had two sets of records coming over in July, which looks very good to us." The firm cleaned up more than 100 per cent. over last July. Last week they experienced a little dullness, but the first part of the month was fine. Mr. Blake will take a vacation the last two weeks of the month, but does not expect to wander far from his luxurious home in the suburbs, where a Blake, Jr., recently arrived, which will divide his vacation interest with the vegetable and flower gardens which he takes so much pride in cultivating in his spare moments. One of the Blake & Burkart boys, Ralph Ziegler, has been sent to Camp Dix, and they were compelled to take on a lady in his place, Mrs. McElwain.

Business of Average Volume

George D. Ornstein & Co. report that Victor business at Eleventh and Chestnut streets is fair for this period of the year. George A. Lyons, Mr. Ornstein's right-hand man, has just returned from a vacation spent at the Delaware Water Gap.

Manager Proudfit Resigns

A. D. Proudfit, who has been the manager of the Victor department of the Theo. Presser store, has resigned, but no successor has as yet been appointed.

A Welcome Summer Visitor

Charles Snow, from the Cressey & Allen firm of Portland, Me., came to this city last week to pay his annual visit to the Victor factory. The combination of Snow and a temperature of 95 in the shade that existed during his visit is something unusual. But he was a

9 1 3
ARCH STREET

WE have moved our headquarters to the above address. Better write it down.

This move is to your advantage and ours, for with our increased facilities we will be able to maintain Penn Service in its highest form of efficiency. Send the next order to

Penn Phonograph Co., Inc.

913 ARCH STREET

PHILADELPHIA

Wholesale Only

BUEHN

SERVICE

on *VICTOR RECORDS*
PHILADELPHIA

7% of your year's business CAN be secured in August. In other words—April sales, May sales and August sales should be about the same. The Fall season starts with August and you can work hard this month with a feeling of being properly rewarded. Musical inspiration is necessary now, for we all want good music. And the best way of getting the world's music is through the Victrola and Victor records. Our policy is to urge you to sell MORE MUSIC. Our efforts are concentrated to maintain Buehn Service at its consistent efficiency.

The Louis Buehn Co., Philadelphia

former traveling man of the Victor, and consequently knows the climate in this section, and it was never known that Snow would melt during his entire association in Camden. And while he may be looked upon as a cold proposition in name he is anything but that in nature.

Well Satisfied With July Business

The Louis Buehn Co. had their usual business in July limited to the amount of goods they were able to receive. Mr. Buehn is spending about half of his time in Ocean City, his summer home, where he is most active in all the life at that resort. Taking everything into consideration the firm reports that they are very well satisfied with their July business. Reports from practically all of their dealers are to the effect that their business exceeded that done during the same month of last year—of course, it could be better were more stock procurable.

Many New Pathé Dealers Appointed

Manager Eckhardt reports that July was a very good month at the Pathé Shop, and that things never looked more promising and encouraging for a tremendous fall business than they do at this time. Many inquiries are coming in from all directions regarding the Pathé proposition and they closed up during the month of July a substantial number of new dealers. "The retail business here," says Mr. Eckhardt, "looks like a tremendous proposition. We are getting a great many new accounts of the real kind."

I asked Mr. Eckhardt what he thought of the outcome of the high tax on machines and records that was going to be levied by the Government, and he replied: "I feel that there is going to be a 10 per cent. tax which will be levied at the source. This will necessitate an increase in price, but unless the increase is prohibitive it will have no effect whatever on business. People purchasing luxuries, such as are musical instruments, are not governed entirely by the price. If the merchandise has merit it will sell, with a reasonable increase,

just as readily as if there were no increase." Warren Clower, of the Pathé shipping department, has joined the army and has been sent to camp at Waco, Tex. C. S. Tay, Mr. Eckhardt's right-hand man, will leave in a week for a vacation which he will spend at Frederick, Md.

Weymann & Son Optimistic Over Outlook

H. A. Weymann & Son had so laid out their plans in advance that they have been able to keep their trade very well supplied in July, and with their stock they have been able to make a good showing. Both in their retail department and as jobbers they found July a most satisfactory month. They have again been able to get their force well organized, after the inroads made upon it by the Government, and Harry Weymann says that he believes they are going to have the largest fall business they have ever enjoyed. Both of Mr. Weymann's sons are in the service, one in the army and one in the

navy, and they have already been heard from in France.

Report an Expanding Business

The Vitanola Distributors Co., 1025 Arch street, report an excellent demand for the very attractive talking machines made by the Vitanola Co., Chicago, in this territory. They are building up a very large business with splendid prospects for the fall.

Latest Brunswick Styles Much Admired

The Brunswick-Balke-Collender Co. are steadily expanding their phonograph business in this territory, and many new dealers have been appointed. The latest Brunswick styles are winning very favorable notice because of the number of distinctive features which they contain.

Prepare for Fall Business

George W. Arnold, of Glassboro, N. J., is making extensive alterations in his warerooms preparing for a big fall business.

DEATH OF MRS. A. DEISINGER

Daughter of Louis F. Geissler Killed in Automobile Accident at Stony Brook, L. I.

Mrs. Nellie Deisinger, wife of Albert Deisinger, of Philadelphia, sales manager of the Fiat Automobile Co., was instantly killed just after midnight on July 30, when a large touring car in which she was riding with her husband was overturned on a sharp curve at Stony Brook, L. I. Mr. Deisinger, who was driving the car, escaped without serious injury.

Mr. and Mrs. Deisinger had driven over from Philadelphia to call on Mrs. Deisinger's father, Louis F. Geissler, general manager of the Victor Talking Machine Co., of Camden, N. J., at his summer home, Tree Tops, Northport, L. I. They had intended to make a tour of Long Island before returning to Philadelphia, and left Tree Tops shortly before midnight. In swinging around the turn at Stony Brook the car is believed to have struck an obstruction of some kind, as it turned completely over.

Mrs. Deisinger was crushed under the heavy machine, but Mr. Deisinger was thrown free of the car and escaped with slight injuries.

Mrs. Deisinger was prominent in the younger society set in Philadelphia, where she was a noted beauty. In addition to her husband she leaves one son, aged four years, and a brother, Arthur F. Geissler, president of the New York-Chicago Talking Machine Co.

OPEN PIANO DEPARTMENT

The Kline, Eppihimer Department Store, Reading, Pa., which for some time past has conducted a very successful talking machine department, has recently installed a line of pianos.

CHANGE OF NAME IN EL PASO

Following the purchase by the Tri-State Talking Machine Co., of the talking machine department of the El Paso Piano Co., El Paso, Tex., it was decided to drop the Tri-State name and the business will in future be conducted under the name of the piano company.

MAXWELL DISCUSSES TRADE CONDITIONS AND THE WAR

Vice-President of Thos. A. Edison, Inc., Writes Most Interesting Analysis of the General Situation Which Is Also Applicable in a Very Large Degree to the Talking Machine Industry

In a lengthy article in the New York Evening Post recently William Maxwell, vice-president and general manager of Thomas A. Edison, Inc., argued most effectively and logically for the establishment of a middle ground between the "Business as Usual" and "Cut Out Luxuries" suggestions that have been so much in evidence to date.

In the opening paragraphs Mr. Maxwell took occasion to decry the existing tendency to exaggerate on the part of public speakers and the public press, particularly in the expressions of opinion regarding what may be held to constitute non-essentials. He wrote in part:

"We, which means our Allies and ourselves, must win the war, and we, meaning ourselves alone, must furnish enough men, enough food, enough arms, enough ammunition and enough equipment of every character to insure beyond all questions that the war will be won by our Allies and ourselves. Furthermore, we must not plan to do exactly enough. We must plan to do more than we really believe is necessary. In carrying out this program, if it is necessary to discontinue the manufacture of automobiles, pianos, jewelry, silverware, phonographs and the several hundred other articles which have been discussed as non-essential, there can be no question in any loyal citizen's mind as to what should be done. I attended a phonograph convention the other day and heard a prominent dealer say: 'I am ready to close my store and become a bankrupt if it will really help win the war.' Some seven hundred phonograph dealers were present, and all of them endorsed this sentiment. So it is with every decent American citizen and every decent American industry. No one wants to be ruined, but every loyal American is willing to be ruined if he must be to win the war. If our young men in uniform are willing to sacrifice their lives, business men should be willing to sacrifice their businesses. There can be no argument on that point. However, if a business man needlessly sacrifices his business, or is needlessly required to sacrifice his business, it is an injury to the nation, comparable in principle, at least, to the needless sacrifice of his life.

"So far as phonographs are concerned, I do not need to argue in their behalf. Music occupies, with literature, the fourth place among human essentials in civilian life, and the experience of army commanders in previous wars, and particularly in this war, has established that music is much more important to the morale

of an army than any form of literature. The American nation, both in and out of uniform, needs music and must have music, if it can possibly be provided. The phonograph supplies more people with music than all of the other musical instruments and musical organizations combined. Phonographs are in great demand at the present time. They are a national need,



William Maxwell

but a need subordinate to the need for ammunition and aeroplanes.

"To the extent that the manufacture of phonographs lessens the output of war equipment, the manufacture of phonographs should be curtailed and inevitably will be, if the necessity really exists. However, I do not think there is anyone in the United States to-day who is able to say what percentage of reduction, if any, should be made in the musical instrument business. I am sure that no one is able to say what increase in war munitions would result if there was a 25 per cent. decrease in the manufacture of musical instruments. Steel, although a relatively small amount of it, is used in the manufacture of phonographs. We know that for some time to come practically all the nation's steel output will be diverted to war work. Accordingly, phonograph manufactur-

ers will experience difficulty in getting steel. Therefore, no official curtailment of phonograph manufacture is required to conserve steel. The steel mills at present are reported to be working to 90 per cent. of their supposed capacity. I believe it will have a wholesome effect on the steel industry if its heads are kept continually conscious of the needs of so-called non-essential manufacturers. It has been my experience that an accumulation of unfilled orders is a potent influence in speeding up production."

Mr. Maxwell then went into a discussion of the fuel and transportation and labor problems and their relations to the business of phonograph manufacturing. He emphasized the willingness of the industry to make sacrifices for the good of the country and the fact that manufacturers in the trade have expressed their desire to aid the Government in every way by devoting sections of their plants to Government work and told of their readiness to take any necessary steps in support of the Government's war program without quibbling when there is a genuine necessity for unusual sacrifices.

ESTABLISH NEW PRICE SCHEDULE

The Progressive Phonographic Supply Co., New York, sole distributor of the Wall-Kane needle, has advised its jobbers throughout the country that, owing to the steadily increasing cost of all materials used in every phase of the manufacture of Wall-Kane needles, the company is compelled to establish a new price schedule. According to this schedule the retail list price of a package of fifty Wall-Kane needles is now 15 cents and new advertising material and display stands featuring the new prices have already been prepared for the use of jobbers and dealers.

In the letter to the trade announcing this change in price D. Tauber, president of the company, emphasized the fact that it is the company's aim to co-operate with and protect its jobbers in every possible way. The new schedule of prices accomplishes this aim in a practical way, and according to present plans the service to be rendered Wall-Kane jobbers during the coming year will even exceed the co-operation offered during the past year.

VICTROLAS FOR SCHOOLS

Harold M. Stillwell, who handles the Victor in Freehold, N. J., is having a big success in selling to schools. He said recently that he had sold Victors to eighteen rural schools, and has found that these sales have stimulated his general business considerably.

NYOIL

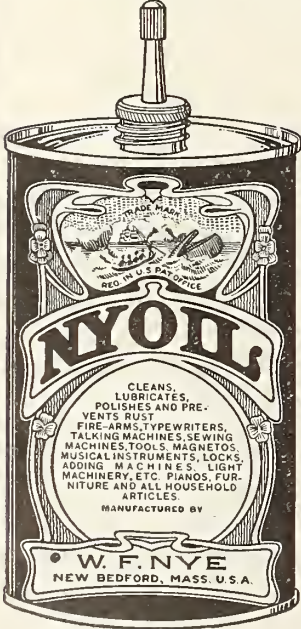

CLEANS, LUBRICATES, POLISHES AND PREVENTS RUST
FIRE-ARMS, TYPEWRITERS, TALKING MACHINES, SEWING MACHINES, TOOLS, MAGNETOS, MUSICAL INSTRUMENTS, LOCKS, ADDING MACHINES, LIGHT MACHINERY, ETC. PIANOS, FURNITURE AND ALL HOUSEHOLD ARTICLES
MANUFACTURED BY
W. F. NYE
NEW BEDFORD, MASS. U.S.A.

is the last word in the refining of high-grade oils, for every impurity is taken from it, leaving nothing but what is required to keep machines in perfect condition, being combined of four oils perfectly blended.

Will not Gum, Chill or become rancid; is free from acid. It is colorless and has no sickening smell, being absolutely odorless.

"The finest and most delicate pieces of mechanism do not prove efficient unless properly lubricated. Skill, Genius, invention and Workmanship must have the proper Oil. Stop and consider this when you have to buy an Oil for household use."

Hundreds of satisfied customers have written us that they would never use anything else for

TALKING MACHINES, GRAPHOPHONES, PHONOGRAPHS AND SEWING MACHINES

NYOIL will lubricate the machinery and polish all woodwork

and can be obtained of any "Up-to-date" Talking Machine Dealer in the world, and is manufactured by Wm. F. Nye, who for 50 years has made 80% of all the Watch, Clock and Chronometer Oil that is used in America.

WM. F. NYE, NEW BEDFORD, MASS., U. S. A.



OILS COMBINED FOR LUBRICATING, CLEANING, POLISHING AND PREVENTING RUST
THE SPORTSMAN'S FRIEND
THE MOST HIGHLY REFINED OIL THAT HAS YET BEEN PRODUCED
Resists Gum, Spring Molecules, Powering, Sticking & Leaking
WILL NOT GUM OR CHILL

NYOIL is put up in the following sizes:

No. 16 (Cans) 1 Pint
No. 32 " 1 Quart
No. 128 " 1 Gallon
No. 540 " 5 Gallon

NYOIL is put up in the following sizes:

No. 1 Bottle 1 ounce
No. 4 " 3 ounces
No. 8 " 8 ounces



UNICO

Designs and Construction
Patented

SYSTEM

THE SALES BUILDER

Unico Demonstrating Rooms
Excel from Every
Standpoint

- DESIGN Six standard styles
Special period styles
- CONSTRUCTION Patented, Interlocking
Portable Units
Sound Insulated
- FINISH All standard Oak,
Mahogany and Enamels
- EFFICIENCY Increased sales at lower
cost per sale
- ECONOMY Moderate first cost
Always an Asset
Adaptable any location
- DELIVERY Prompt shipments from
stock ready for im-
mediate use



Unico Racks and Counters
Maximum Capacity
Minimum Space

- DESIGN Patented to correspond
with Unico Rooms
- CONSTRUCTION Sectional Units adapta-
ble to any space
- FINISH All standard Oak, Ma-
hogany and Enamels
- EFFICIENCY All records always
available instantly
- ECONOMY Moderate Equipment
Cost
Lower Operating Cost
- DELIVERY Prompt shipments from
stock in all finishes

Install a
Complete Unico Department



- DEMONSTRATING ROOMS
- RECORD RACKS
- RECORD COUNTERS
- CEILING DECORATIONS
- ARCH TREATMENTS

The Unico System has
Increased Sales and Profits
for almost 1000 dealers



Send to-day dimensions of your available space. Plans and
estimates for a complete department will reach you promptly

THE UNIT CONSTRUCTION COMPANY

RAYBURN CLARK SMITH, President

Fifty-eighth Street and Grays Avenue, PHILADELPHIA, U. S. A.





Columbia steps forward again! The new model Grafonolas are ready! The highest type of phonograph made today.

Write for detailed description
of exclusive features

Columbia Graphophone Co.
NEW YORK

UNUSUAL RECORD OF ACTIVITY IN KANSAS CITY TRADE

Comparative Figures Show Business Volume for July Ahead of Same Month for 1917—Cash Sales Predominate—Many Members of Trade Join Uncle Sam's Forces—News of Month

KANSAS CITY, Mo., August 9.—The talking machine trade in Kansas City for the month of July was ahead of the month of June and also ahead of the same month in 1917. This is an unusual record, considering the many obstacles in the form of price advances and scarcity of merchandise. "We are having the biggest record business in the history of the store," said Miss E. Surendorf, manager of the Starr Piano Co. C. V. Bissell, formerly general manager of the local branch of the Starr Piano Co., was called into service a month or two ago and is now en route to the East, where he will leave for foreign service. Mr. Bissell was made corporal in the Thirty-fourth Infantry, which has been stationed at Camp McArthur, Tex. It was with mingled regret and pride that members of the firm regarded Mr. Bissell's departure. Miss Surendorf comes to Kansas City from the factory at Richmond, Ind., to take charge temporarily until a permanent manager is appointed. F. C. Comer still retains his position as retail sales manager.

Burton J. Pierce, manager of the Victrola department of the J. W. Jenkins' Sons Music Co., is also head of what is probably the "sportiest" family in the talking machine trade. Mrs. B. J. Pierce and Charles E. Thayer won the mixed

Scotch foursome play at the Meadowlake Club July 31. Their net score for the nine holes was 31. Following the round of golf, an old-fashioned picnic dinner was spread in the orchard of the clubhouse. At the Rotary Club picnic July 27 Miss Genevieve Pierce won the ladies' singles in the tennis tournament, the 75-yard dash and the potato race. Mr. Pierce was captain of the winning baseball team at the same affair.

D. M. Guthrie, retail manager of the Columbia Grafonola Shop, will leave very shortly on a two weeks' motor trip to Colorado. Mr. Blackstock, repair man for the Columbia, is visiting his old home in Mississippi.

The talking machine department of the Jones Store Co. finds business far ahead of last year, not only in volume but also in the quantity of goods sold. "We are getting terms on machines which are almost unheard of. A large part of our business is on the 50 per cent. cash basis," said Mrs. Nelle Williams, manager. A. R. Willey, salesman, who has been handling the foreign trade, was called to the colors July 22 and has left for Camp Crook, Neb. Mrs. Nelle Williams, manager, will leave shortly on a two weeks' camping trip in the Ozarks.

"There is a big demand for machines and no

goods," said B. J. Pierce, manager of the Victrola department of the J. W. Jenkins' Sons Music Co. "It is very difficult to adjust the business to conditions." C. L. Kipp, of Manhattan, Kan., and Mr. Walters, of Walters & Behrens, Atchison, Kan., were recent visitors to the Victrola department of this store.

"Business has been very good," said A. A. Trostler, Victrola department of the Schmelzer Arms Co., "and July has been ahead of the same period a year ago. Trade is keeping up nicely and the demand is still as great as ever with no prospects of a let up. Anything which looks like a Victor sells." Mr. Trostler recently returned from a week's trip to the Victor factory, where he went to see about securing merchandise. The Schmelzer Arms Co. has adopted the one-a-day delivery plan.

Miss Frick, formerly connected with the Jenkins' Victrola department, has been added to the force of the Schmelzer Arms Co. She will later replace Miss Hill as assistant to Mr. Lyman in the wholesale department.

The wholesale department of the Phonograph Co. of Kansas City finds trade conditions very good. July was ahead of last year, and the prospects for August are the best that the company has ever had. O. M. Fisk has been added to the sales force, replacing C. L. Smith, now of the national army, in southwestern Kansas and eastern Oklahoma territory.

G. H. Clevidence, of the credit department of Edison wholesale, has left for the Great Lakes Naval Training Station. Mr. Clevidence is replaced by W. C. Hall.

Roy Kroger, head of the talking machine department of Brunswick wholesale, has joined the navy and left for the Great Lakes Naval Training School. Mrs. Paul Oviatt is now in charge.

The Brunswick wholesale reports a steady business throughout the summer season. "The volume of business during July was 20 per cent. larger than during June," said Mrs. Oviatt. "In fact, the conditions have been better than we anticipated, in view of the usual slowing down in demand." B. Altman, formerly a piano salesman with the Altman Piano Co., has taken the position of assistant to Mrs. Oviatt.

L. S. Blythe, Missouri, Kansas and Oklahoma salesman for the Brunswick, has just returned from a thirty days' trip through his territory. The following firms have contracted as dealers for the Brunswick: Schrack & Son, Pratt, Kan.; M. Y. Rusk, Brookfield, Mo.; and Harry L. Hass, Milan, Mo.

Mr. Darrow, of the Darrow Music Co., Tulsa, Okla.; Lewis Megede, Richmond, Mo.; and C. L. Dosch, Mayville, Mo., were visitors at the Kansas City Brunswick headquarters.

J. W. McQueen, McQueen Bros., Carrollton, Mo., has just received word from France that his son was slightly wounded in battle.

M. M. Blackman, manager of Edison wholesale, has recently taken up golf. Judging from Mr. Blackman's enthusiasm, members of the office force prophesy that he will be able to meet "Chick" Evans to the latter's discomfiture by next season's tournament.

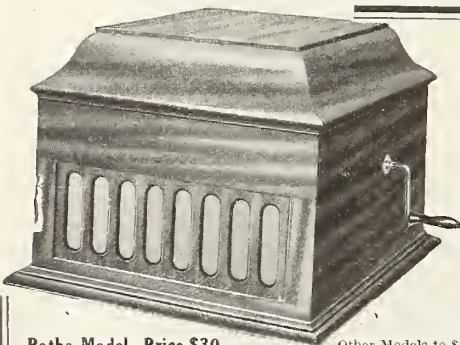

Pathe Model, Price \$30

Other Models to \$225.

No Needles to Change
The Pathe Sapphire Ball takes the place of needles. It need not be changed.

Long Life to Records
The Pathe Sapphire Ball cannot possibly cut, grind, rip or mar the record's surface.

The Pathe Controla
With the Pathe Controla you may increase or decrease the tonal volume of the Pathe Phonograph at will.

Plays All Records
Each Pathe Phonograph plays not only Pathe Records, but all other makes of disc records, and plays them perfectly.



Muratore—Exclusive Pathe Artist

Pathe

Take the Three of Them

Pathe Phonographs

Pathe Records

Fischer 24 Hour Service

And you've got an unbeatable combination working to make money for you.

THE FISCHER COMPANY

Oldest Pathe Jobber

940 to 1040 Chestnut St., Cleveland, Ohio

BELIEVES IN CASH PAYMENTS

F. E. Yahr, of the Yahr & Lange Co., Carrying on Campaign to Educate Retail Trade to Importance and Value of Cash Payment Plan

MILWAUKEE, WIS., August 3.—The Yahr & Lange Drug Co., of this city, wholesale distributor for the Sonora phonograph in this territory, has been achieving splendid success with this line, and has established successful and responsible dealers in practically all of the leading cities in its territory. Fred E. Yahr, secretary of the company, who is in active charge of the Sonora division, is an enthusiastic believer in the "cash payment" plan of selling phonographs, which forms an important part of the Yahr & Lange Sonora campaign. George E. Brightson, president of the Sonora Phonograph Sales Co., New York, has congratulated Mr. Yahr upon the success he has attained in this important work.

In a recent chat with The World Mr. Yahr commented as follows upon the progress his company is making in this direction: "We are educating our dealers to sell Sonoras on a cash basis only. They all seem to appreciate the value of this plan now that we have put them on this basis. Heretofore, they thought it impossible to sell Sonoras for cash, but they have changed their minds and are now rejoicing in the clean business they are doing.

"Some of our dealers handle two and three makes of phonographs which they sell on time payment, but they tell the customer at all times that the Sonora cannot be sold on 'easy terms,' and they find that the larger sales are of the Sonora, as the customer invariably forms a better opinion of an instrument that is sold on this basis instead of one that they can purchase on 'convenient terms.'

"As Mr. Brightson put it, 'pride of possession' is a very true saying, and I hope eventually that all merchandise will be sold on this basis. Then

dealers will be able to go home and rest in ease and not spend half of the night worrying about poor accounts and how they are going to pay their jobbers for the merchandise which they have out on time payment.

"We have in the neighborhood of 150 good live dealers handling the Sonora in the city of Milwaukee, the State of Wisconsin, and in Upper Michigan, and we have educated them all up to the cash payment plan. We have added to our list of dealers the G. W. Fischer Furniture Co., of Milwaukee, which is located in the heart of this city, and is one of the largest and finest furniture stores in the State of Wisconsin. They placed a large order last week for Sonora instruments, including a representa-

tive assortment of every model in this line. "A year ago we only had about fifteen accounts in our Sonora department. We secured one dealer during the month of June, 1917; this dealer constituting our first new account. Considering the fact that we now have 150 successful Sonora dealers on our list, we think that we have accomplished pleasing results in one year.

"The Sonora is coming to the front very fast in Wisconsin, and we are certain that we will be able to dispose of all the Sonora instruments that we will be successful in obtaining from the factory. We have now in the neighborhood of two thousand instruments on back-order with the Sonora Co."

DEATH OF JOHN M. DEAN

Founder of the Well-Known Needle Manufacturing House of That Name Passed Away Recently at His Home in Putnam, Conn.

John M. Dean, founder of John M. Dean, Inc., the well-known needle manufacturer, which was recently incorporated as a division of the Otto Heineman Phonograph Supply Co., died recently at his home in Putnam, Conn. Mr. Dean had been ill for some time, but with his customary vigor and energy had taken a keen interest in his many business and social connections notwithstanding his illness.

John M. Dean was well known throughout the country as a pioneer in the talking machine needle industry. He founded the concern of John M. Dean, Inc., many years ago, and through his intimate familiarity with the most important mechanical details of needle manufacture, succeeded in gaining for the Dean needle world-wide recognition. Dean needles steadily increased in popularity year after year, and recently John M. Dean, Inc., became one of the divisions of the Otto Heineman Phonograph Supply Co.

In addition to his prominence in the talking machine industry Mr. Dean was also well known in general industrial circles, for the concern which he founded manufactures vast quantities of textile pins, comb, faller, feeder and card pins. The house is known from coast to coast as one of the leading manufacturers of these products and since the war broke out has been handling very large Government orders.

Mr. Dean is survived by two daughters and two sons, John M. Dean, Jr., and Charles E. Dean, both of whom have been active in the executive direction of the Dean needle factory for many years. Under the able guidance of their father they obtained a thorough knowledge of every detail of the business, and since the amalgamation of John M. Dean, Inc., with the Otto Heineman Phonograph Supply Co. they have perfected many plans for expansion.

The funeral services were held August 2 from Mr. Dean's late residence in Putnam and were attended by many well-known manufacturers in the textile field and personal friends and acquaintances. W. C. Strong represented the Otto Heineman Co. and numerous floral wreaths testified to the esteem and affection in which Mr. Dean was held by all who knew him.

To Jobbers and Dealers

Especially those selling Hill-and-Dale Records

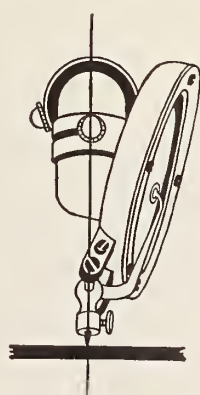

YOU can greatly increase the demand for the best Records by selling these Reproducers and Attachments applying them to standard machines.

Write for Quantity Prices Liberal Arrangement for Jobbers

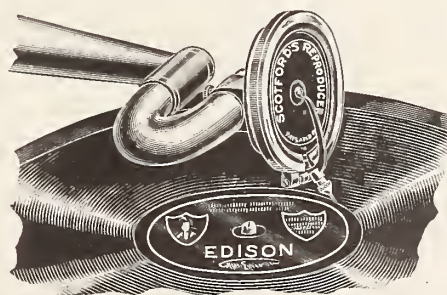

Superior Universal Reproducer

The Reproducer that pivots on its axis—taking the correct angle for all makes of Records—and the needle retains the same center in both positions

	Sample Prepaid	Retail Price
With Attachment for Victor	Nickel 4.10	Gold 5.00
With Attachment for New Victor	Nickel 3.50	Gold 4.25
With Attachment for Columbia	Nickel 3.70	Gold 4.55
With Attachment for Edison	Nickel 4.10	Gold 5.00
With Attachment for Pathe old style arm	Nickel 3.70	Gold 4.40
As is—it fits the new universal arm	Nickel 3.15	Gold 3.75

*This refers to the latest type having the enlarged Tonearm

"The Superior Universal Reproducer gives a depth of sound that is so wonderful that all other sound-boxes that I have ever heard seem obsolete. Besides this marvelous depth and warm richness of tone, it has the great advantage of a surprising musical volume. In all makes of records overtones and undertones never before heard with other Reproducers are brought out with pure, crystal-like clearness. Your Reproducer places the needle in exactly the right angle for either the Columbia and Victor or the Pathe and Edison Records. It is one of the few which safely play the Edison Diamond Disc Records without skidding across the record, which causes the jewel point to dig into the record and ruin it. Other makes slant too much, therefore there is always the tendency for them to slip from the groove and skid. All that I have said of the Superior is also true of the Scotch Model 1, that wonderful Reproducer of yours that, with its large diaphragm, plays the Pathe, Edison, Lyric and other vertical-cut records with so great and beautiful a tone. I have sixteen different Reproducers fitted to my machine, but I know that for perfect articulation, beautiful tone and volume, your sound-boxes have no equal."

Wilmington, Delaware
March 28, 1918

Alfredo L. Demorest
Vice-Consul of Paraguay

Scotford Model 1 Reproducer

The original Scotch Reproducer—plays only Hill-and-Dale Records, but plays them at their best

As is—it fits the	Sample Prepaid	Retail Price
Victor	Nickel 3.50	Gold 4.10
With Attachment for Columbia	Nickel 3.75	Gold 4.45
With Attachment for Pathe	Nickel 4.05	Gold 4.75

Can be used on the Edison with the Kent Attachment

Barnhart Brothers & Spindler
Manufacturers of Superior Specialties for Phonographs
Monroe & Throop Sts.—Chicago



Something *New* under the sun! The Columbia NON-SET Automatic Stop. The only "self-stopper" on the market.

Write for description
of the new models

Columbia Graphophone Co.
NEW YORK

RECORD TRADE OF ENORMOUS DIMENSIONS IN MILWAUKEE

Trade Problem Is to Get Sufficient Stock to Meet Demands—General Trade Very Seasonable—Machine Shortage Causing Some Concern—Advertising Campaign Along Co-operative Lines Pays

MILWAUKEE, Wis., August 12.—While the demand for talking machines is showing something of the usual midsummer slackening, due to the fact that hundreds of families which might be classed as potential prospects are in the country during the torrid spell, dealers are kept busier than ever in trying to fill the extraordinary requirements for records. Not only is the demand for these the largest it has ever been, but it is growing every day and Victor dealers particularly are at their wits' end to know how to supply all orders.

"The record situation is the most acute that is known in our experience," said Harry A. Goldsmith, secretary of the Badger Talking Machine Co., Victor jobber in Wisconsin and Upper Michigan. "We cannot get more than a part of the stocks of records which we require to meet the demand from our dealers. The main reason for this is that their wants are far and away above anything we or they have ever encountered. With a record supply that could hardly be expected to grow apace with the demand, due to the urgent needs of the Government for materials, facilities and the records themselves, the trade is illly equipped to face the constantly expanding demand.

"One reason why so many records are wanted is that the market virtually has been flooded with any number of machines of a more or less nondescript nature—machines that have no records to back them up. This throws the entire burden of furnishing records to play these machines upon the few concerns which are engaged in the manufacture of records as well as machines. Dealers everywhere report that their stocks are badly broken, and it is a constant scramble to replenish supplies."

Concerning Victor machines Mr. Goldsmith said that the situation still is very unfavorable, as not enough can be obtained to fill orders. At this time, when sales of machines are probably at the low point of the year, due to the season, foresighted dealers are taking advantage of the temporary lull in getting under cover for their requirements during the coming fall and holiday season. For this reason the demand as viewed by jobbers is perhaps just as great as ever, and the chances of providing machines are no better than before, because the

factories cannot increase production when more pressing Government requirements are being given attention.

None of the other big jobbers in Milwaukee, all of whom supply a large share of the demand from the retail trade in Wisconsin and Upper Michigan, are in much better shape than their competitors, although here and there may be found a house that is perhaps better fortified on stocks than another. These jobbers, however, regard the future with some apprehension on this point, for while they may have fairly moderate supplies of machines at this time, there is no telling what may happen when the demand is resumed early next fall.

At the Edison Shop, 213-215 Second street, Edison jobber and retailer, it was stated that while dealers' orders are being fairly well filled, there is a shortage of some styles. The company has been making a brave attempt to anticipate requirements during the last half of the year, but finds that stocks are diminishing more rapidly than expected. So far as records are concerned, hardly enough can be obtained to fill current orders, to say nothing of laying up stocks.

Thomas I. Kidd, general manager of the Brunswick-Balke-Collender Co., 275-279 West Water street, has been fairly successful in keeping his dealers stocked and is working like a beaver to give them the machines for which they are clamoring to protect themselves next fall. Mr. Kidd foresees a shortage sooner or later if the demand is anything like he expects it to be.

The Sonora is moving better this summer than last, according to Yahr & Lange, 207-215 East Water street, Sonora jobbers for Wisconsin and the Upper Peninsula. The company's dealers are exercising foresight in anticipating their wants ahead, and in addition to placing these orders in large volume, need many machines to fill immediate requirements. Under the vigorous promotion of Yahr & Lange, the Sonora has won remarkable prestige all through the territory and this is now being reflected most strongly in the demand.

A. G. Kunde, 516 Grand avenue, distributor of the Columbia, says the big demand for Columbia records is causing him even greater concern

than the matter of getting enough machines. The Columbia catalog has never been so popular as now, and old as well as new issues are being snapped up by retailers as rapidly as they become available.

"Wisconsin certainly appreciates Wisconsin products," said Charles J. Orth, 504 Grand avenue, distributor of the Puritan phonograph and Paramount records in this State and Upper Michigan. "It may be true in some things that 'A prophet is not without honor, save in his own country,' but not so with the Puritan. We have been able to offer dealers the double advantage of quick deliveries and ample stocks, and this has brought us a really enormous volume of business. The factories at Sheboygan, Port Washington and Grafton are so close to everywhere in this State that while some dealers in other machines need a couple of weeks to fill orders for certain styles of which they are out, we can deliver the goods almost the same day. We are building up a splendid record business with the Paramount line, which also is made right here in Wisconsin, both because the goods are 'right' and service is quick."

The acute shortage of labor has had its effect upon the retail as well as the jobbing trade. All dealers are lamenting the fact that it is practically impossible to get men, but at the same time they realize that the movement of the boys to the front is bringing the dawn of peace much nearer, and they are making the

"The Music Without the Blur!"

This ideal of talking machine manufacture is attained more nearly than by any other, in the construction of the

MARVELOUS MAGNOLA "Built by Tone Specialists"

"Magnola's Tone Deflector eliminates the scratch"



Watching the Music Come Out

We want to show you how to make money with MAGNOLA; and how MAGNOLA is the best buy on the Talking Machine Market to-day.

Send us your name and let us send you some real Talker Tips.

MAGNOLA TALKING MACHINE COMPANY

OTTO SCHULZ, President

General Offices
711 MILWAUKEE AVENUE
CHICAGO

Southern Wholesale Branch
1530 CANOLER BLDG.
ATLANTA, GA.



PERSONAL SERVICE

The members of our Company are always available and will gladly see you personally or write you at any time we can possibly serve you.

Why not communicate at once with us?

BADGER TALKING-MACHINE CO. 135 Second Street
MILWAUKEE, WIS.
VICTOR DISTRIBUTORS

best of the situation in a patriotic way. It is to-day not an uncommon sight to see the head of a retail store behind the wheel of a delivery car, taking the place of a young man who has answered the call to the colors and for whom no substitute can be found. Rather than destroy reputations for service, the executives are not afraid to do this class of work, and, as a matter of fact, they really enjoy getting out and coming face to face with problems and situations that are new in their experience.

The death of Walter Ruez, a popular traveling representative of the Badger Talking Machine Co., Victor jobber, on Saturday, July 20, cast a pall of gloom over the entire force, and especially over George F. Ruez, president of the company, who thus lost his only brother. Mr. Ruez was only thirty years old, but earned for himself a splendid reputation in the field and his passing caused genuine sorrow throughout the territory. The funeral was held July 24 at Fond du Lac, Wis., the former home of the Ruez family. Mr. Ruez is survived by his mother, Mrs. H. Ruez, three sisters and his brother, George.

Edward Heath, who took Mr. Ruez's place when he was stricken about four months ago, has taken the route permanently.

Miss Helen Gunnis, manager of the Music Shop, 310 Grand avenue, retailer of the Columbia and Starr, has gained new laurels as a soprano by her appearances as soloist at the free concerts under municipal auspices in the public parks of Milwaukee during the summer. Miss Gunnis is a concert soprano of wide note and at the recent National Music Show in New York sang at the Universal Music booth every evening. She has done much recording for both the Columbia and Aeolian-Vocalion records.

Gimbel Bros. are making a big hit in their soldiers' and sailors' department by the installation of recording machines of the Dictaphone Co. for the benefit of customers who desire to send records of their voices to the boys "over

there." Hundreds of people have recently taken advantage of the offer.

"Jack" Stapleton, of Watertown, Wis., a popular Edison representative in the Wisconsin territory until his resignation to enter the military service, has won a commission as second lieutenant in the aviation service, much to the gratification of a host of friends in and out of the trade. He has just completed his training course at Kelley Field, San Antonio, Tex., and for the present will be attached to Camp Dix.

Talking machine dealers of Milwaukee and Wisconsin are coming forward loyally and liberally in support of the Music Industries Preservation Fund, the campaign for which is being directed by Edmund Gram, Steinway and

Aeolian-Vocalion representative at Milwaukee.

The Milwaukee Association of Music Industries has recently concluded its second big advertising campaign along co-operative lines, and all members express themselves as more than repaid for the expense. The talking machine men are just as enthusiastic as the piano dealers over the beneficial results. Both divisions of the trade received equally forceful representation in the series of advertisements. The campaign involved an outlay of about \$1,200, making a total of \$5,000 or more expended by the Milwaukee Association during the last nine months to boom music in Milwaukee and vicinity. It is likely that a third campaign will be undertaken during the coming fall.

SECURE NEEDLE SHIPMENTS

C. Bruno & Son, Inc., Able to Supply Dealers With Their Popular Criterion and Mezzo-Tone Steel Needles—Suggest Early Orders

C. Bruno & Son, Inc., were successful recently in securing two shipments of their popular Criterion and Mezzo-Tone steel needles. These needles have been on the market for several years, and Bruno dealers have presented these needles to their customers with the absolute assurance that they will give perfect satisfaction. In view of the tremendous shortage of needles and the fact that these shipments are decidedly limited C. F. Bruno has suggested to the dealers that they place their orders at the earliest possible moment.

PLANNING LIVE FALL CAMPAIGN

P. J. Doherty, sales manager of the Language Phone Method, returned to his desk August 12, after a two weeks' vacation. Mr. Doherty is now planning the fall campaign of the company, and their language course will be featured more strongly than ever during the coming months.

TO ISSUE 1,000 MILEAGE BOOK

For Use of Travelers Rather Than 5,000-Mile Book as Originally Planned

The National Association of Piano Travelers was advised last month that the authorities in Washington had made a change regarding the issuance of a mileage book for travelers, and that instead of issuing a 5,000 mileage book, they had decided to issue only a 1,000 mileage book. This book can be used for the payment of regular fares on any railroad in the country, and can also be utilized to pay for Pullman and dining car charges. The Government authorities, however, have decided definitely that the use of this mileage book does not exempt the traveler from paying the extra charge of one-half cent per mile for riding on a Pullman.

TO ORGANIZE ASSOCIATION

OAKLAND, CAL., July 30.—The talking machine dealers of Oakland, Berkeley and Alameda met here last week for the purpose of discussing the formation of a talking machine association, the object being the general betterment of the business.

The Leonard Markels BUTTERFLY MOTOR

The Leonard Markels Jewel Bearing Butterfly Motor

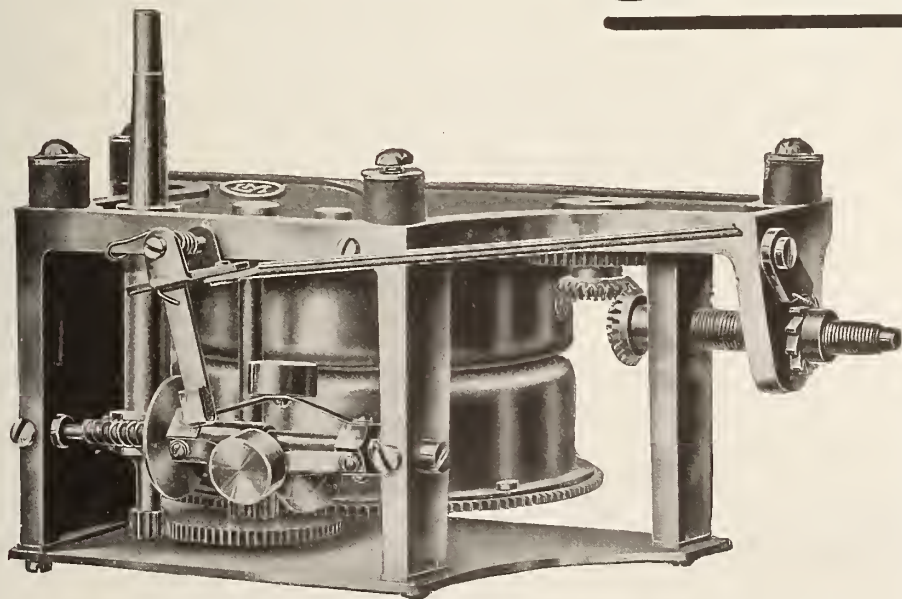

Specifications

- Beveled gear noiseless winding,
- New ratchet device that prevents clicking.
- Bakelite intermediate gear—absolutely silent.
- Plays seven 10-inch or five 12-inch records at one winding.
- Cast iron nickeled frame.
- Powerful, durable, compact, accessible.
- Built especially for the highest-grade machines.
- Guaranteed in every minutest detail.

has revolutionized the motor industry. It is silent running and silent winding and represents the acme of perfection in motor construction.

This motor has achieved phenomenal success, and is being used exclusively by leading phonograph manufacturers in all parts of this country and Canada.

Write today for a copy of our New Butterfly folder

LEONARD MARKELS - 165 William St., New York

SAN FRANCISCO TRADE ACTIVE, BUT STOCK IS SCARCE

Conditions, However, Better Than a Month Ago—New Columbia Models Interest—Changes in Personnel of Phonograph Shop—Walter S. Gray Doing Well—Hauschildt Activity

SAN FRANCISCO, CAL., August 4.—As far as the demand for talking machines and records is concerned few complaints have been registered by local dealers in the past month, as sales have held up unusually well for the summer vacation season. The wholesale distributors report the demand well up to expectations also, but in some lines the shortage of stock is a serious handicap, and more and more uneasiness is felt in regard to getting ample supplies to meet the requirements of the Western trade during the coming holiday season.

While the local branch of the Columbia Graphophone Co. is in a little better position in regard to stock than it was at the end of June, the supply of machines is still so short that it is impossible to go out after business in an aggressive manner. A shipment or two arrived during the past month, but they came on a bare market and practically all the machines contained therein were sent out again immediately on back orders. Much interest is shown in the few samples of the company's new automatic self-stop models, which have just been received here. Manager F. A. Denison considers this new feature a revelation in the talking machine business, and he looks for it to stimulate the demand for Columbia products on an extensive scale. It will be largely a question of being able to get stock during the remainder of the year in his opinion. Mr. Denison spent part of July at Santa Cruz, Cal., having had a very pleasant vacation there.

Andrew G. McCarthy, of Sherman, Clay & Co., says the demand for Victor goods is just as good if not better than ever before, but the problem of getting stock seems to grow more serious all the time. From present indications he thinks there will be many disappointments as the year advances, because of inability to get Victrolas here on the Pacific Coast.

J. W. Carson, manager of the Edison Shop on Geary street, off Union Square, which handles Edison products exclusively in a retail way, spent the first half of July vacationing in the northern part of the State. Congratulations are in order, as he was married the latter part of June and turned his vacation into a honeymoon trip. Upon his return to the store he was pleased to find that business had held up very well during his absence.

A. C. Ireton, of Edison Phonographs, Ltd., received visits recently from Mr. Marshall, who looks after the company's interests in the Northwest, with headquarters in Portland, Ore., and Mr. Lovejoy, the company's representative in southern California. Both Mr. Marshall and Mr. Lovejoy brought favorable reports from their respective territories.

After spending a few weeks at the Phonograph Shop in Stockton street, where Sonora phonographs are featured in a retail way, E. M. Bonnell, traveler for the Sonora Phonograph Co., left a few days ago for Los Angeles.

Several changes have taken place recently in the personnel of the Phonograph Shop's force. C. T. Compton has gone into another line of business, after being connected with the establishment since its beginning, and Miss Tully, another employe who had been there some time, has given up her position, it being understood she is to be married shortly. Among the new faces to be seen at this store is N. D. Dumphy, who arrived in San Francisco recently from the Northwest.

Manager F. B. Travers, of the Sonora Phonograph Co., is back on duty after an enjoyable outing in the redwoods north of here.

Walter S. Gray, who is engaged in the talking machine trade accessory business with offices in the Chronicle Building, is calling on the trade in the southern part of the State. He has been successful in making very desirable needle connections and is doing a big business in this branch of talking machine supplies, which has won for him the title of "needle king" of the Pacific Coast.

Frederick Stern, head of the Stern Talking Machine Co. at 1085 Market street, which also has branches in Oakland and Richmond, Cal., is making a strong feature of the Pathé line and reports excellent results. In Richmond the business has grown to such an extent that new quarters are necessary. The company has leased the store at 1111 Macdonald avenue and is having the place nicely fitted up for occupancy at an early date. The move will be in the nature of a celebration of the first anniversary of the business in that city.

The San Francisco trade received a pleasant visit from Geo. P. Hopkins, sales manager of the Columbia Graphophone Co., during the past

month. The principal object of his trip to the Pacific Coast was to attend the annual convention of the Associated Advertising Clubs of the World, which was held in this city, but while in the West he took advantage of the opportunity to call on various Columbia agencies and to make a general survey of trade conditions in this section of the country. He stopped in Los Angeles, Cal., on his way here, and then proceeded homeward via the Pacific Northwest.

The California Phonograph Co., of which F. A. Levy is president, has been handling quite a bit of export business, having a special license to make such shipments and special permission for its men to go aboard off-shore vessels entering this port. As each consignment of records leaving the store for a foreign destination has to be censored and bear a Government seal, the work of filling the orders and preparing the records for shipment is no small task. Mr. Levy has just returned from a long automobile trip.

The Fresno, Cal., store of Sherman, Clay & Co., under the management of E. R. Armstrong, is undergoing extensive improvements, which will provide larger and more desirable quarters for the talking machine department of the business.

Mrs. Helen Plummer Howard has made a splendid showing in increasing the sales of the talking machine department of the Hauschildt Music Co.'s store in Oakland, Cal., since taking



Joint Float of Hauschildt Co. and MacDonough Theatre in War Savings Stamp Drive

charge of that part of the business a few months ago. Her work along educational lines continues to increase in scope. During the recent War Savings Stamp campaign, through her efforts and the courtesy of the Hauschildt Co. and the MacDonough Theatre, a Brunswick talking machine did service on a truck in the streets six hours daily. She has also placed a Brunswick machine in the lobby of the MacDonough Theatre, having some one in charge to play it from 11 in the morning to 9,30 at night each day, specializing between acts on the current comic operas. Mrs. Howard reports that the gratuitous equipping with talking machines of various ships called into United States service either as training or troop ships is still going on and she is convinced that the boys in our service truly appreciate "that music will help to win the war." Her company has also sent machines to the boy scout encampments, together with records. Recently the Hauschildt Music Co. and one of the Oakland newspapers gave a theatre party at a local moving picture house to which the children of the various orphan and relief societies of Oakland were invited. A vaudeville and moving picture program was arranged, using a Brunswick talking machine for two numbers.

At the invitation of Henry Hauschildt, of the Hauschildt Music Co., the talking machine dealers of Oakland, Alameda and Berkeley, Cal., met at the company's Oakland store a few days ago for the purpose of discussing plans for co-operation and better working methods on the east side of San Francisco Bay. The meeting was well attended and will likely bring about a closer understanding among the trade in that section.

What can you do when you have come to what seems the limit of your powers, the end of your string but just—keep on. It will win.

MELOPHONE MOTOR

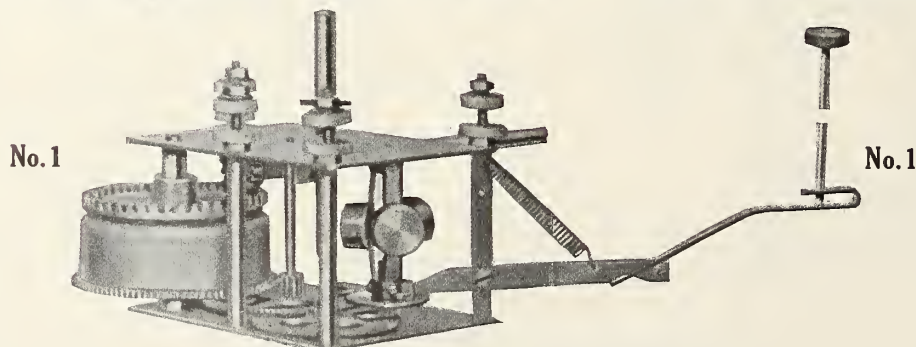

COMPLETE WITH 10-INCH TURN TABLE

Simple in construction, the most satisfactory and durable of all small motors.

Will play two ten-inch records with one winding.

Three years' successful record as the best single spring motor manufactured.

Immediate Deliveries Sample \$2.00

Write for Quantity Prices

Melophone Talking Machine Co.

380 Lafayette Street, New York

Royal Serbian Orchestra at the Waldorf Astoria



In New York all the best people visit the Waldorf Roof for their rendezvous. The Waldorf-Astoria, desirous of choosing the best kind of entertainment, picked for the summer season the celebrated Royal Serbian Orchestra.

It's the talk of the town—in fact the talk of the country—every manufacturer wanted to be the first to offer records of this orchestra.



But first out as usual, it's

Emerson Records

No. 955, the new large size Emerson disc consists of the Belovarska One-step and the Slobode Waltz, by the Royal Serbian Orchestra. This is but one of the many new popular song and dance hits from the Catalog of large discs.



The New Large Size Records Are

65c
EACH

You will hear the Tambouritza, a sort of combination between the mandolin and the guitar. Music that is novel and unique and makes you want to dance.

This first Emerson Record of the Serbian Orchestra is conducted by Zerbes, the great Serbian conductor and violinist.



EMERSON Records are the most economical buy today; the only records which can be played on any machine without attachments; and the most widely wanted discs.

FIRST OUT WITH THE BIG HITS

Emerson Phonograph Company INC

3 West 35th Street - - New York City

The Emerson Phonograph Company
3 West 35th Street, New York

Gentlemen—

Kindly send me full details and particulars about your new large size Records at 65c each.

Name

Address

City

ADVERTISING THE VOCALION RECORD

Mammoth Advertising Campaign Inaugurated by the Aeolian Co. Covering Their New Records—Artists Are Individually Featured

As announced recently in The World the Aeolian Co., New York, has completed plans for a mammoth advertising campaign in behalf of the new Aeolian-Vocalion records. This campaign has already been launched in the



Giulio Crimi

newspapers throughout the country, and judging from the enthusiastic reception accorded the first advertisements in this series, this publicity will not only produce sales for Vocalion



Miss Florence Easton

dealers, but will serve to emphasize the prestige and quality of the Vocalion records.

When this record campaign was being prepared the advertising department of the Aeolian Co. endeavored to inaugurate something distinctive, and after carefully considering various plans it was decided to introduce Vocalion records through the medium of advertising that would feature one record by one specific artist. As the Aeolian-Vocalion record library includes selections made by many famous artists who are recording exclusively for the Aeolian Co., this plan of publicity presented many attractive features.

In announcing the initial recordings by the

ILSLEY'S GRAPHITE PHONT SPRING LUBRICANO

Ilsley's Lubricant makes the Motor make good. Is prepared in the proper consistency, will not run out, dry up, or become sticky or rancid. Remains in its original form indefinitely.

Write for special proposition to Jobbers.

MANUFACTURED BY ILSLEY-DOUBLEDAY & CO., 229-231 Front St., New York Established 1853

distinguished tenor, Giulio Crimi, the Aeolian Co. featured two records presenting selections from "Cavalleria Rusticana" and "Pagliacci." This advertisement appeared in the leading newspapers in this city, and was noteworthy for its attractive illustration, which carried out the idea of the "Cavalleria Rusticana" selection, as well as for the unusual manner in which this

A Vocalion Record
of rare charm

"THREE GREEN BONNETS"
Sung by FLORENCE EASTON

ONLY a wistful little musical tale—but sung by a great artist with a heart-stirring appeal that will make this Vocalion record a cherished possession.

Three tiny maidens in quaint green bonnets who have spent the carefree days of childhood together—blue-eyed Daisy, little Dulcie of the clear grey orbs, and brown-eyed Dorothy May.

With what exquisite tenderness of soul beauty does Florence Easton, the famous soprano of the Metropolitan Opera Company, invest the name of Dorothy May—fore-shadowing in the very simplicity of her artistry the song's plaintive finale—when the angels have called home the little brown-eyed maiden.

Think of the satisfaction of being able to follow every word of Handel's charming ballad in this marvelous Vocalion record.

Through the impressive tone-realism of the Aeolian Company's new and improved system of recording, not only is the individual quality of Florence Easton's beautiful voice given amazing reproduction, but each clear-cut detail of her remarkable enunciation—enabling the listener to enjoy every syllable of this rare little musical gem to its close.

VOCALION RECORDS—representing the highest modern development of record-making and interpreted musically through the master photograph, the Aeolian-Vocalion, reveal the limitless possibilities of this exclusive method of tone reproduction.

THE AEOLIAN-VOCALION

PLAYS all standard makes of records with greater tonal naturalness than any other phonograph and bestows upon owners of these wonderful instruments the added advantage of enjoying through the most satisfying and musically medium—the new Vocalion Records.

THE AEOLIAN COMPANY
In MANHATTAN, 29 West 42nd Street
In BROOKLYN, 11 Flatbush Avenue
In THE BRONX, 101 East 149th Street
In NEWARK, 895 Broad Street



STYLE "G"
PRICE \$12

Advertising the Florence Easton Records record was introduced to the music-loving public. Mr. Crimi records exclusively for the Vocalion record library, and his records will doubtless meet with the hearty approval of Vocalion dealers everywhere.

Another advertisement in this interesting series called attention to "A Vocalion Record



Artistic Design of Head of Crimi Ad of Rare Charm," this record being "Three Green Bonnets," sung by Miss Florence Easton, of the Metropolitan Opera Co. This distinguished soprano, who also records exclusively for the Vocalion library, has made an individual place for herself in European operatic circles and has been hailed as one of the most valuable acquisitions to the Metropolitan Opera Co.'s staff in recent years. She has appeared in many important roles during the past season, and the success she has attained has definitely established her as a gifted artist of rare ability.

The text of the advertisement announcing Miss Easton's record was noteworthy for the distinctive treatment accorded the description

The Perfect Tone
OPEROLLO
For Every Home

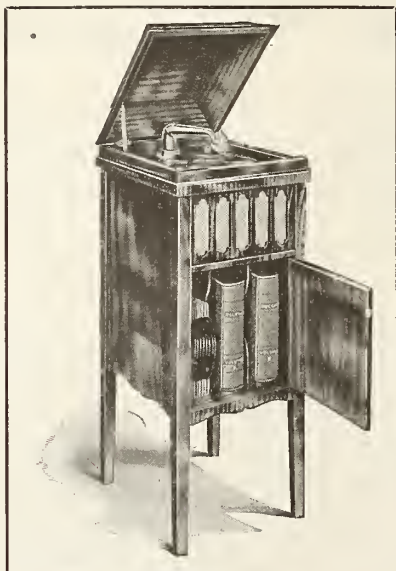

MODEL "F"

40 inches high 18 inches deep 15 inches wide

RETAIL \$45

Write for Special Discounts of ALL our Models

Immediate Deliveries in Any Quantity

OPEROLLO-PHONOGRAPH COMPANY
54 W. Lafayette Blvd. Detroit, Mich.

Distributors
Wall-Kane
Needles

Distributors
Lyric
Records

of this record. The border design of this advertisement was also unusually attractive, and as may be seen by the accompanying illustration, was well calculated to attract the attention of newspaper readers. Miss Easton's record has already achieved signal success, and her addition to the staff of Vocalion artists is welcome news for Vocalion representatives.

INTERESTING VICTOR LITERATURE

August Supplement Contains Interview With Victor Herbert—Lists of Foreign Records

The Victor Talking Machine Co. have recently sent out their August supplement, a feature of which is an exclusive interview with Victor Herbert in which he speaks of the recording of his patriotic "American Fantasia," which, given complete, excites his enthusiastic approval. He also speaks of how American music will be favorably influenced by the war. The interview as a whole is most interesting and characteristically Herbertian.

This company have also sent out a number of foreign record lists, including Victor records in Greek, Italian, Lithuanian, Norwegian, Roumanian, Serbian, Slovak, Swedish and Yiddish. In every community there is a large foreign element to whom this music from the "mother country" is of profound interest, and it makes a strong appeal where properly presented by talking machine dealers. In this connection the Victor Co. very aptly point out: "Don't forget the foreign-born Americans in your own town, for they occupy an important place in the industrial development of the nation."

LIKE THE SEEBURG PHONO-GRAND

The McKannon Piano Co., Denver, Colo., who recently took on the representation of the Phono-Grand, the combined piano and phonograph made by the J. P. Seeburg Piano Co., are quite enthusiastic about this instrument and have brought it to the attention of the local public in some very striking advertisements.

EXPERT CALCULATOR NOT ALWAYS A GOOD BUSINESS MAN

Merchant Who Measures His Business Progress by Pretty Figures Rather Than Facts Is the Sort of Fellow Who Helps to Make the Sheriff's Job Worth Fighting For

The lightning calculator is a fine thing at the bookkeeper's desk if he is honest, but as the boss, the main stem of the works, he has got to be a Hindoo on business sense to get by. As the Big Mogul he is too likely to get his figures all mixed up and put the business on the toboggan by counting for effect rather than for results.

Take Joe Smith, for instance, who deals out machines with the left hand and records with the right at his joint up the street. Joe can count so fast he can understand election returns the same night they appear on the screen. They even say he can watch a ton of coal sliding down a chute and tell you the exact number of lumps. The trouble is he figures his business accounts the same way, and they mean nothing in his young life, except figures. The result is that every time the Sheriff passes the door he throws out his chest, rubs his hands and frames a mental picture of himself standing in the doorway and acting as undertaker for the business.

Joe dopes it out that everything sold means a profit. He hustles around for a month to get a \$100 machine, then sells it to the first guy that blows in at \$1 down and \$1 when he catches him. Just to make the deal right he will slip in a couple dozen records at the same time. Then Joe sits at his desk and puts down the amount of money he expects to get from the customer sometime for the machine and records. Underneath that he puts the cost price, does a little subtracting, and the rest is profit. The rent, when he pays it, the light, the value of his time, and the interest on his money are simply little matters not worth bothering about. Then he spends another month getting a duplicate machine to sell to another wise guy on the same terms. It's fine for the buyers, but awful medicine for Joe. He is getting it in homeopathic doses, but when the dope starts to get to him, Oh, boy!

At the same time this figure hound is wondering why the pile of bills in the till is getting higher as the pile of cash is getting lower. Some day this boy is going to get wise to himself and throw the fast figuring overboard for the slow, steady count. He is going to dope out the fact that the only money he makes is what is left after he has paid for his goods, paid all his expenses and gets his money from the customers. Then he is liable to do a brodie, because he will find out that sometime there won't be any money left except on the wrong side of the ledger.

A baby with these generous propensities should not give away goods to strangers. With a disposition like that he ought to have enough clinging friends to keep the business going until the stock is cleaned out. At the same time he should break into his siesta long enough to spend a profitable hour watching Solly down the street holding out for the hard coin for his machines, telling the world fair that he had a hard time to get them and don't expect to get any more, and demanding of the same world that it come across clean with the kale or nothing doing. The only bills Solly's got in his till are greenbacks and a bunch of mortgages at 5 per cent. on other peoples' houses, which shows that Solly is a wise guy, at that.

When it's raining soup it's no time to grab a fork. The wise guy knows this and goes forth with a bucket. It's no time to let go those goods for a buck down and a promise. When the lightning calculator gets down to cases, goes back to the elementals, as it were, and begins to count slowly like a donkey on the stage, using his hoof instead of his head, then he is going to find that figures in business don't mean anything unless they have got a great big dollar sign in front of them.

MORAL: Don't take water when gravy is plentiful.

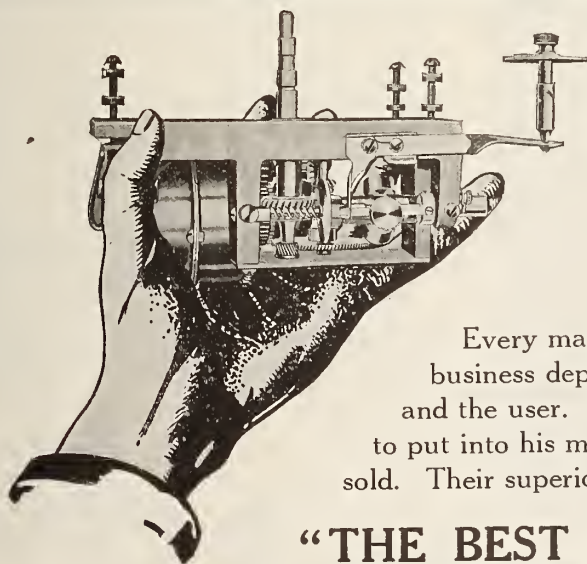

Dayton Motors

Sold all over the World
Used in all high-class Talking Machines

Every manufacturer building talking machines knows that the success of his business depends wholly upon the satisfaction his products give to the dealer and the user. Therefore, he realizes that only the best parts are good enough to put into his machines. That's the reason thousands of Dayton Motors are being sold. Their superiority makes them

"THE BEST MOTOR IN THE WORLD"

They embody the highest quality of mechanical perfection. Made in different styles and sizes; noiseless, easy-winding and durable. Build satisfaction into your products by using our Quality line. Dayton Motors, Dayton Tone Arms, Dayton Reproducers.

They will bring you more business and satisfy your customers.

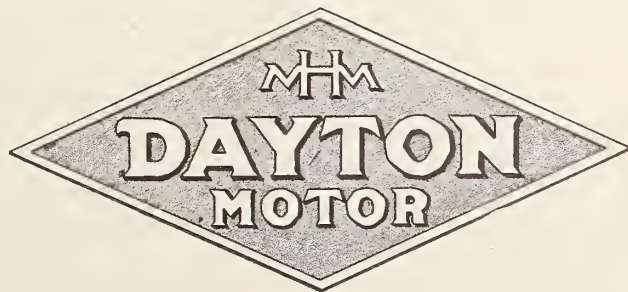

Write for full particulars

THOMAS MFG. CO., 322 Bolt St., Dayton, Ohio, U.S.A.



The New Model Grafonolas give you, Mr. Dealer, more and *better* sales arguments than any other instrument on the market.

Write for full description

Columbia Graphophone Co.
NEW YORK

CLEVER USE OF TALKING MACHINE

Machine in Canadian Hospital So Operated That Music Is Carried Through Electric Wires Direct to the Patient's Bedside

An interesting adaptation of the talking machine for the purpose of entertaining hospital patients is reported to be in use in a hospital in Ottawa, Canada. The device, it is stated, consists of a spring driven motor connected with a turntable similar to the ordinary phonograph without a horn. Attached to the cabinet is a special music-transmitter, corresponding to the tone arm and reproducer on the ordinary phonograph. The transmitter is energized by the vibrations of the needle traveling on the record, and transmits these electrical vibrations over a system of wires throughout the hospital. The wiring terminates at outlet jacks alongside of patient's beds. The patient can be furnished with a head receiver attached to a cord and plug. When the plug is inserted in the jack near the bed, the patient may hear the music by placing the receiver against the ear. The recorder is inaudible unless the receiver is held close against the ear, and consequently one patient may receive entertainment while the patient in an adjoining bed may sleep without disturbance.

The Raymond Phonograph Co. is now manufacturing talking machines in Atlanta, Ga.

Increase Your Record Sales

by forcing the owner to maintain his files

DO IT

by furnishing him a file index which he will use

Proper Index is the Secret The Handy Record Index

EASY TO MAKE
EASY TO KEEP
EASY TO USE

In Convenient Form

for the owner to hand to his friends in answer to their question of "What records have you?"

Its Use A Pleasure

inducing the proper maintenance of files and thus the

PURCHASE OF MORE RECORDS

HARRISBURG BOOK CO.
Commonwealth Trust Bldg.
HARRISBURG - - - PENN.

EDISON SUPERVISORS RECLASSIFIED

Warren F. Taylor Among Those Recently Appointed to Position of Supervisors

The following reclassification of Edison supervisors and their territories became effective August 1, 1918:

H. R. Skelton, Boston, New Haven, Albany, Syracuse, New York and Williamsport.

C. S. Gardner, Pittsburgh, Cleveland, Cincinnati, Richmond and Philadelphia.

C. W. Burgess, Des Moines, Sioux City,



Warren F. Taylor in the Laboratory
Omaha, Denver, Ogden, Helena and Kansas City.

J. A. Shearman, Dallas, Atlanta, New Orleans and St. Louis.

W. F. Taylor, Milwaukee, Minneapolis, Chicago, Indianapolis and Detroit.

Warren F. Taylor, whose appointment to supervisor has just been announced, joined Thomas A. Edison, Inc., about ten years ago as a junior clerk. Unlike most juniors, Taylor acted as though his job was the best job in the place. Naturally that prevented him from remaining an office boy very long, and by 1915 he had risen to the important position of sales

ELECTRO-PLATING of PHONOGRAPH PARTS

AND MUSICAL INSTRUMENTS
Gold, Silver, Nickel and Antique Finishes

JOSEPH MUSANTE

168 CENTRE ST. Tel. Franklin 3053 NEW YORK

correspondent. When a place on the Edison supervising staff became vacant, Taylor was chosen to fill it.

He is pictured here "absorbing," which is part of the training Edison supervisors get before they go on the road. Having spent several weeks in the laboratories learning how Edison phonographs are made, he is now ready to go out and help spread the gospel of music's recreation.

JOINS UNCLE SAM'S FORCES

Harry Schoenthal, who was formerly a member of the traveling staff of the local wholesale branch of the Columbia Graphophone Co., covering the northern part of New York State, is now in the National Army, and expects to leave for camp in the near future. Lambert Friedl, manager of this branch, states that Mr. Schoenthal's successor has already been chosen, and will be introduced to the trade next week.

DEATH OF MRS. WARBURTON

Mrs. Mary Helen L. Warburton, widow of Fred'k J. Warburton, who was formerly vice-president and a director of the Columbia Graphophone Mfg. Co., died July 26 at her home in Scarsdale, N. Y. Funeral services were held at her late residence July 27, and the interment took place at Loudon Park, Baltimore, Md., the following week.

What More Can You Ask

All the features that go to make a talking machine *Profitably Salable* you will find as regular equipment of Magnola: "Built by Tone Specialists."



Watching the Music Come Out

Complete description of all these features is to be found in our *handsome illustrated catalog*, which we should like to send you. May we? Ask us to tell you our plans for your benefit!

MAGNOLA TALKING MACHINE COMPANY

OTTO SCHULZ, President

General Offices
711 MILWAUKEE AVENUE
CHICAGO

Southern Wholesale Branch
1530 CANDLER BLDG.
ATLANTA, GA.



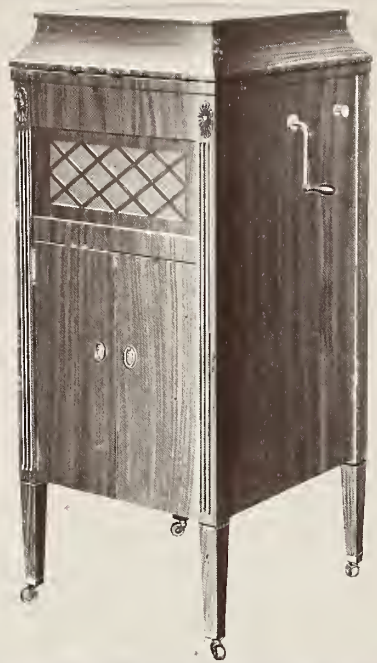

NO. 95



NO. 120



NO. 4



NO. 60

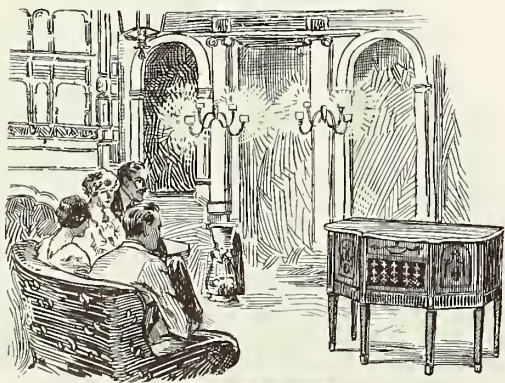

The **STRADIVARA** Art Phonograph

"KNOWN FOR TONE"
(PATENTED)

has neither concealed horn nor metal throat, nothing but a flat, life-giving sound board made out of choicest spruce. The tone is of velvety smoothness without megaphonic, metallic, or piercing effect. It reproduces tone true to life without change, but it cannot make a bad record good.

The workmanship is exquisite and the proportions are correct. Genuine mahogany, oak, and walnut are used only. The entire instrument is fully warranted, and the strong motors are as near trouble proof as possible.

The **STRADIVARA** "Known for Tone" represents a good and honestly made standard line; sold without undue bombast, but fulfilling every promise made. It repre-



15

NO. 175

NO. 200

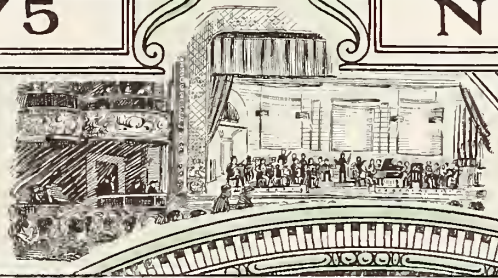

sents distinctly an advance in the science of applied phonetics.

We will ship to thoroughly responsible firms any one of these seven models upon ten days' approval, and desire one dealer only in each locality of less than fifty thousand. Our discounts are attractive and pay a good profit to our representatives. A wide range of advertising material is available to help in selling service.

Will you not write us today and may we not help you to the acquisition of a deserving line which invites favorable comparison?



NO. 250

Manufactured by

THE COMPTON-PRICE CO.
 COSHOCTON, O.





WAR PICTURES HELP DRAW BUSINESS IN INDIANAPOLIS

Views of Battle Front a Strong Display Feature at Brunswick Shop—Call to Service Disrupts Organizations—Excellent Business Prospects in Agricultural Districts—News of Month

INDIANAPOLIS, IND., August 6.—Midsummer finds business conditions among the wholesale and retail talking machine dealers in the Hoosier capital quite satisfactory. In a number of instances the business of July this year exceeded by a considerable margin the business of the same month last year. The dealers are getting a better class of business and doing more business at the same time. The policy of demanding larger payment down and larger weekly and monthly payments is in force quite generally.

George F. Standke, manager of the Brunswick Shop, believes in giving the people what they are interested in along with selling them Brunswick machines. In the Brunswick Shop window in North Pennsylvania street hangs each day a photo of some of the boys who are fighting the Huns across the water. These pictures are supplied by the Committee on Public Information.

To illustrate the extent to which the public is interested in such matters Eph Inman, a prominent Indianapolis attorney, stopped in front of the Brunswick Shop recently to look at one of these photos and found his son, Lieutenant Gilbert H. Inman, lying on a hospital cot. Needless to say he was surprised. Lieutenant Inman had notified his parents of being gassed a short time before.

Mr. Standke is posting all the photographs so received along the walls on the second floor of the shop and has invited the public to inspect the pictures at any time. There have been a number of instances where persons have recognized soldiers in these pictures.

Through the courtesy of Mr. Standke the Optimists' Club at a recent meeting at the Hotel Lincoln had the pleasure of listening to General Pershing through the medium of a Columbia record and a Brunswick machine.

Mr. and Mrs. Standke are the proud parents of George, Jr., just arrived.

Ben L. Brown, manager of the wholesale business of the Columbia Co. here, reports considerably more business in July than in the same month last year.

"The only trouble was to get the goods," said Mr. Brown. "We had enough orders to reach a very heavy increase over the same month last year but simply could not get the machines and records to fill complete orders."

The war cut into the Columbia wholesale organization recently. Louis Sayer, representing the branch in Kentucky as traveling salesman, is in the spruce forests of the Northwest as foreman of a gang of foresters. Herman Schuesler, former shipping clerk, now at Camp Taylor, Kentucky, has been promoted to a corporal.

William Daly, of Louisville, Ky., has succeeded Mr. Sayer as traveling representative in Kentucky for the Columbia Co.

Frank J. Clark, manager of the Dictaphone department of the Columbia wholesale branch here for the last four years, has left to open up branches in the northern part of the State. He will establish offices at Fort Wayne and South Bend. He has been succeeded by C. A. Wilkinson, formerly with the Globe-Wernicke Co.

Frederick Aylesworth, manager of the Vocalion department of the Aeolian Co., says that the prospect for exceptionally promising business in the country districts of the State is good because the wheat crop of the State was successful and farmers have money. Business has been brisk with the Vocalion.

A. H. Snyder, of the Edison Shop, reports business conditions very good. George W. Kadel, formerly sales manager of the Edison Shop, has joined the tank service and is in training at Gettysburg, Pa. H. L. Lewis and H. G.

Parker, former Edison Shop employe, are in the service, Lewis with the Quartermaster's Department in New York City, and Parker with the marines.

J. L. Peters, the new manager of the retail store of the Columbia Co., is getting things in shape for a big business this fall. He is having some redecorating done in the shop. July business with the Columbia retail shop was exceptionally good, Mr. Peters said, July business being almost double that of a year ago. And this was in the face of a decided shortage of machines and records.

James Stewart, who was manager of the retail store of the Stewart Talking Machine Co., which handles the Victor line, has gone to the Culver Military Academy for a course of military training. Business with the Stewart Co., both wholesale and retail, has been excellent.

DELIVERING THE "RESURRECTONE"

Joseph Hoffay, president of the Hoffay Talking Machine Co., Inc., states his firm are now delivering the "Resurrectone," their patented reproducer to the trade. Letters are being sent out to the trade notifying them that the reproducers are made in several models to fit the various makes of machines, and it is necessary when ordering to state the make of instrument. Mr. Hoffay says the trade is showing enthusiasm regarding the Hoffay sound box, and the company's earliest predictions are being met in the results obtained. He further states that the tones obtained through their product in playing operatic selections are proving valuable to dealers who use the "Resurrectone" in demonstrating their records.

Fred H. Putnam, head of the Putnam-Page Co., Peoria, Ill., Victor distributor, is receiving the congratulations of his many friends in the trade upon the arrival at his home last week of a baby girl. This young lady has been christened "Marion," and she is already giving realistic indications of a future operatic career.

SOMETHING NEW

THE FLETCHER REPRODUCER

EXACT SIZE



After years of practical experience and experimenting, we are pleased to offer a Reproducer constructed on entirely new principles. In its natural reproduction of tone, either vocal or instrumental, it astonishes and pleases beyond expression, and a Caruso, Galli Curci or Heifetz sounds as if the artists themselves were before you.

The Fletcher Reproducer is different from the ordinary sound box, not only in construction, but in results. You hear no metallic noises, but an accurate reproduction of the human voice or musical instrument as it is recorded. If used with a fibre needle it will give practically as much volume as with a steel needle and save the wear on the record. The Fletcher Reproducer brings out detail on the record that cannot be heard with the ordinary sound box.

The Fletcher Reproducer is different. Hear it and be convinced. A sample order carries with it a guarantee of satisfaction or money refunded. Samples to dealers and manufacturers \$4.00.

Write for prices and terms in quantities.

FLETCHER-WICKES CO. 6 E. LAKE STREET CHICAGO - ILL.

THE TRADE IN BOSTON AND NEW ENGLAND

JOHN H. WILSON, MANAGER, 324 WASHINGTON STREET, BOSTON, MASS.

BOSTON, MASS., August 5.—Curtailement of business through Government needs, tax embargoes and the natural shortage of goods and labor are the topics that are being most discussed these days in the trade; but to offset this is the pleasant fact that there appears to be no curtailment in the demand for machines and records on the part of the general public, and it is a perplexing problem that faces the jobbers and dealers in not being able to supply goods in the large quantities demanded. Many instances are being told of the large orders received by the distributors from out-of-town dealers who are having a heavy call for this or that record, and when allowed only a small percentage of their order are most indignant, and cannot see—at least they so express themselves—why a much larger fraction of the order cannot be filled. Were there enough goods there is no question that business in both machines and records would be very large.

Herbert L. Royer's Handsome Cheney Quarters

Having taken the New England agency for the Cheney phonograph product Herbert L. Royer has fitted up a suite of rooms at 77 Summer street, where a number of the latest models of this excellent machine may be seen by dealers. This is the first time the Cheney line has been shown here, and apart from the excellence of the cabinet work the tonal system has many unusual features which have brought it to the attention of a discriminating class of people. In fact, it is understood that it is the sound principles involved in phonographs which have been given the greatest study before this type of machine was allowed to be placed before the public. Mr. Royer has placed in charge of the Cheney department George Krumschied, who has had a wide experience in the talking machine business, and who has many friends in the trade. Another new member of this staff is F. R. Witman, who comes to Boston from New Bedford.

Studying Factory Facilities

Manager Fred E. Mann, of the Columbia, has been spending a week in New York, Springfield and Bridgeport, at the latter place making a close study of all the factory facilities and conferring with officials there and in New York as to the future of business and the factory output. Manager Mann reports business as very good and is only limited by the lack of goods. Two new concerns which have lately taken on the

Columbia line are C. H. Tilden, of Keene, N. H., and H. G. Applin, of Davis Square, Somerville. Both houses are planning to do big things with the Columbia product.

Booked Many Pathé Orders

Wholesale Manager R. O. Ainslie, of the Pathé phonograph and record department of the Hallet & Davis Co., of whom a likeness is herewith given, has been spending a month in the Middle West making a careful survey of the territory. Mr. Ainslie went from here



R. O. Ainslie

straight to Chicago, where he conferred with officials there; and then started out to get into close touch with dealers spending much time in Wisconsin, for it is Mr. Ainslie's purpose to meet in person as many Pathé dealers as is possible as by that means it is easier to do business with them later through a more complete mutual knowledge of the Pathé product and methods of doing business.

Sonora Co. in New Quarters

The Sonora Co.'s Boston headquarters have been moved from the Little Building in the downtown section to 221 Columbus avenue, where in what is known as the Pope Building it now has one-half of an upper floor entirely devoted to its uses. Southern New England Representative Richard Nelson has a private office, a salesroom, business office and large stockroom facilities, and he is in far better position

than ever before to meet the demands of the trade. Mr. Nelson has just taken on the Vocal-style player-piano rolls for which he becomes the New England distributor.

Opening of Bates & Holdsworth Store

The opening of Bates & Holdsworth establishment at Framingham was necessarily postponed until July 27 because of the fact that the establishment was not quite ready; but when the doors were opened the public had an opportunity of enjoying an unusually beautiful and comfortable graphophone department. J. F. Carr, manager of the dealers' service department of the Columbia Co., and C. E. Sheppard, one of the sales associates of the same house, whose line is featured in the Bates & Holdsworth establishment, were dinner guests at the home of one of the partners, after which they returned to the store where all the sales force was assembled, and Manager Carr gave an interesting and illuminating talk on the Columbia product and the most advantageous ways of merchandising it. Mr. Holdsworth, by the way, is now overseas in Uncle Sam's service.

New Edison Records Liked

There seems to be universal praise among all the Edison dealers for the quality of the new Edison records that are now being put out by the company and the traveling staff of the Pardee-Allenberger Co. have everywhere found the actual and prospective owners of Edison machines quite enthusiastic over the latest Edison list. For this reason a very good business is looked for this fall.

Awaiting New Brunswick Models

Manager F. H. Walter, of the Brunswick-Balke-Collender Co., says his department is awaiting the arrival of a group of new models in which he has been interesting the trade during the past few weeks. These machines are expected here any day. Manager Walter plans to start on a short vacation in about a fortnight.

Steinert Employes in Nation's Service

Robert Steinert, head of the Arch street Victor department of M. Steinert & Sons Co., has been spending several days down at the firm's New Haven, Conn., quarters. Mr. Steinert had a most enjoyable but active time attending camp as a member of the Motor Corps of the State Guard. The Steinert house has added another to its large list of employes who have gone into service. The latest is J. W. Graham, who

Behind the Co-operation

we are now extending in Eastern Victor Service lies the hope, that when the great world war has come to a victorious close we may look back on a period during which we attained a reputation among Victor dealers for giving practical help to them in the solution of their war-time problems.

EASTERN TALKING MACHINE CO.

177 TREMONT STREET

BOSTON, MASS.

THE TRADE IN BOSTON AND NEW ENGLAND—(Continued from page 40)

Send for Descriptive Circular

Curry DEMONSTRATION BOOTHS
AND RECORD CASES
IN STOCK OR TO ORDER

"SOUND PROOF"

FRANK B. CURRY
19 Wareham St. Boston, Mass.

has entered the radio school at Newport, R. I. He has been a salesman in the wholesale department of the Victor department. J. W. Mahoney, of this department, divided his vacation between Hampton Beach, N. H., and Nantasket; and Perley B. White has just left for a trip along the Maine coast.

Following are the names of the employes of the Grafonola Co. of New England who are now serving in the army and navy: Thomas McDonald, army, in France; James McDonald, Motor Department, army, in France; J. M. Harlow, Ordnance Department, army, in France; Louis Besserer, soloist, in band, army, in France; John O'Hara, navy; John Burke, navy; Frank Mills, Officers' Training School, army; Herbert Fleming, Aviation Corps, army; Stanley Bowman, navy; and Clyde Skinner, Aviation Corps, navy. In a circular making this announcement Manager Arthur Erisman says: "We are proud of them; their positions are open on their return."

One of the Alsen Brothers Injured

News was received toward the end of the month of the serious injury to John Alsen, manager of the Edison and Victor departments for George Lincoln Parker, who went overseas last September with the 101st Engineers. Mr. Alsen is a resident of Dorchester, and he was the first of three brothers to enter service. One brother, Henry C. Alsen, was with the headquarters division of the 104th Regiment when he was killed a few months ago; a third brother, Ellis Alsen, is with the Signal Corps of the 101st Field Battalion. John Alsen, it will be recalled, has been eager to have *The Talking Machine World* sent to him regularly since he has been overseas and more than once he has written of the great enjoyment he got from perusing its pages.

Stimulating War Stamp Sales

Manager Arthur Erisman, of the Grafonola Co. of New England, has perfected a system which is playing an important part in winning the war. He has each customer write his name in a book and these are numbered consecutively up to one hundred. When the hundredth name is filled in there is a drawing and the lucky winner is given a \$5 War Stamp, which is an im-

mediate incentive to start upon a war saving plan, provided the winner has not already done so. There already have been several to win these War Savings Stamps and the possession of one stamp has been the means of the recipient purchasing several more.

Joins Vocalion Co. Forces in Boston

Thomas W. Hindley, recently manager of the Vocalion Co.'s store in Providence, is now attached to the Boston warerooms of the company, where he is assisting Manager R. S. Hibshman. Mr. Hindley has had a wide experience, and before going to Providence was in New York City, where upon his arrival from the West he was engaged by Manager Hibshman for his Providence establishment. On the side Mr. Hindley is something of an architect and out in the mining sections of the West he has designed any number of the bungalow types of houses for the miners' families. A. E. Russell, of the sales force of this Boston store, is enjoying a vacation down in Maine. Manager Hibshman, who is one of the enthusiastic members of the State Guard, has been with that organization at Camp Augustus P. Gardiner at Framingham.

New Emerson Dealers Signed Up

H. L. Coombs is the manager pro tem. of the Emerson Co., and he has been on the job here in the Boston office since the middle of July, coming here first while Manager Oscar W. Ray was enjoying a vacation with Mrs. Ray in the Vermont hills which they traversed on horseback. Mr. Coombs has been associated with the Emerson long enough to become quite familiar with the company's product and its methods of doing business, and he is rapidly learning the ins and outs of Boston. Two new Emerson dealers, just signed up, are A. M. Phenney, of Hyde Park, and the C. H. Mohler Co., of Cambridge.

A Visitor From Texas

Fred Erisman, who for some time was in the graphophone business in Boston, is here from Dallas, Tex., where he says business is fine and he only regrets that the South has not some of the Northern energy and hustle. In the store of which he is the manager, he says he is constantly making sales of high-priced machines and that nearly every transaction is for cash. Mr. Erisman is visiting his brother, Fred C. Erisman, head of the Grafonola Co. of New England.

Entertain Army and Navy Men

Patrons of the army and navy Y. M. C. A. at Charleston were treated to a concert a few nights ago at which the contributing talent in-

cluded Richard Constantino, son of the famous tenor, Constantino; and Miss May Grady, these singing both solos and duets. Both Constantino and Miss Grady are on the staff of the Grafonola Co. of New England.

Returns From Vacation

Ralph Longfellow, manager of the Victor and Edison departments of Chickering & Sons, is back from his vacation spent at some of the resorts on Cape Cod. William McDonald, of this same department, is back on the job after a vacation at Barnstable, Edwin J. Hayes has been at Hyannis and John J. McCarthy is home from Martha's Vineyard.

TAKES ON THE COLUMBIA LINE

GARDNER, MASS., August 6.—George J. Carroll, of this town, whose drug store on the best corner of the city is widely known to everyone passing through this place, has taken on the Columbia line, and from the first he has been doing a very good business. The store has good facilities for demonstrating records, and Mr. Carroll is in particular having a large call for the new patriotic numbers in which his customers are greatly interested.

FORBES & WALLACE IN GREENFIELD

The Forbes & Wallace piano store is now located in new and spacious quarters in the Columbus Block, Greenfield, Mass., where a large stock of pianos, Victrolas and records are displayed. The business is under the management of A. R. Filante, with Miss Woodruff in charge of the talking machine and record department. This is a branch of the same company which has headquarters in Springfield.

NEW MANAGER FOR STEINERT

Miss Kathryn A. Cassidy is now in charge of the talking machine department of the M. Steinert & Sons Co. store in Providence, R. I., succeeding Miss Nora Cullinane, who has joined the staff of the talking machine department of the Outlet Co. Miss Cassidy is the daughter of Hugh Cassidy, manager of the Steinert store in Woonsocket, R. I.

NOTED VIOLINIST A VISITOR

Jascha Heifetz, the noted violinist and Victor artist, recently paid a visit to the M. Steinert & Sons Co., Providence, R. I., purchasing several Victor records for use at his summer home at Narragansett Pier.

— Oldest and Largest
Manufacturers of Talking
Machine Needles in the
World—There are several reasons

W. H. BAGSHAW CO., Lowell, Mass.

NORMAL SUMMER CONDITIONS PREVAIL IN BUFFALO TRADE

Business Little Better Than This Time Last Year, Dealers Say—New Brunswick Dealers—Fine Columbia Report—Pushing Pershing Records—Utley Incorporates—A Budget of Live News Items

BUFFALO, N. Y., August 6.—Buffalonians at this writing have received relief from a terrific hot wave which temporarily threatened the prosperity of the talking machine business and kindred lines for a few days. The welcome drop in temperature has now restored to the trade its normal summer activity. During the torrid spell the talking machine stores were veritable "sweat boxes," on which high-powered electric fans seemed to make little impression. "It's the humidity that gets me," was a typical statement of a local talking machine customer to a dripping-browed salesman. Of course, the local summer resort trade in machines and records was satisfactory as the mercury soared into the nineties and drove many Buffalonians to cool spots along Lake Erie and Niagara river. Even in spite of the fickleness of the weather July trade is generally reported to have surpassed the mark of a year ago.

The Hoffman Piano Co., of 696 Main street, and M. Turchin, 160 East Ferry street, have been appointed Brunswick talking machine dealers. Frank Long, a first-class mechanic and finisher, is employed at the Brunswick's Buffalo branch. He came here from the company's factory. At this branch a new "phonograph mezzanine," which is electrically lighted and has new fixtures, has been completed.

"Our July business was unduly good," said W. J. Bruehl, sales manager of the retail store of Neal, Clark & Neal, Victor dealers. He reports that the articles in the newspapers and magazines, referring to the contemplated tax on musical instruments, created quite a demand for Victrolas among those anxious to escape that tax. B. E. Neal, vice-president of the

company, has returned from a month's vacation. E. J. Dingley, representative of the Victor factory, was a Buffalo visitor. He has charge of the allotment of all Victrolas and records from the factory to the distributors.

"Our increased business in July was 75 per cent. over that of the same month a year ago," said O. M. Kiess, manager of the Columbia's Buffalo branch. "The new patriotic records have the call. We had our first car of the new type of Grafonolas equipped with the new non-set, automatic stop. We allotted the carload among as many dealers as the supply would permit and they were much pleased with the samples."

Mr. Kiess has made a deal with the Buffalo branch of the First National Film Co., lessors of the patriotic films, "Pershing's Crusaders," and "My Four Years in Germany," by Ambassador Gerard. "According to my plan," said Mr. Kiess, "the records that the Columbia Co. has just issued, by General Pershing and Ambassador Gerard, will be featured in connection with the showing of these films in the entire western half of New York State. The idea is that our local dealers will supply a Grafonola and the records to the local moving picture theatre showing these films. We expect to get valuable publicity from the plan for our dealers as well as largely increased sales on the Pershing and Gerard records."

Paul Kuehn, of Walden avenue, has sold his Victor agency to the Buffalo Music Co., 708 Swan street.

Isadore Melzer, Victor dealer of 1048 Broadway, has joined the U. S. Navy and is receiving instructions at Great Lakes, Ill.

The Utley Piano Co., Inc., capitalized at \$50,000, has been incorporated in this city. This concern handles the New Edison. The directors of the company are Mary B. Utley, Albert Stettenbenz and Thomas R. Wheeler. Mr. Stettenbenz managed the Utley store for several years. The new company will continue the business conducted by the late C. H. Utley.

Many Buffalonians have plenty of money for talking machines and records and are spending it freely for this purpose. Among the recent customers of a local store was a youth of nineteen, who is reported to be receiving \$1 an hour at construction work at a local steel plant. Many other similar cases are recorded. Even the blistering heat can hardly check the onward flow of trade. That talking machine music is a wartime necessity is clear.

Mr. and Mrs. Hoffman, of the Hoffman Piano Co., Sonora and Brunswick dealers, are summering at Wilson, N. Y. The latest addition to their sales force is John Van Norman and Mrs. Shantel.

Charles Hereth recently motored through Cattaraugus county, where he developed satisfactory business on the New Edison.

H. G. Towne, Victor manager for Robert L. Loud, is displaying striking vacation posters headed: "Take a Victrola with you this summer." He was visited recently by his former assistant, E. O. Hock, who is at Camp Upton. Lingard Loud is in the aviation department in Texas.

John McCormack, whose records are favorite sellers in Buffalo, was elated over the financial results of his concert held here recently for the benefit of the Knights of Columbus war fund.

Alvin Kaepfel, of the Kaepfel Piano Co., has enlisted in the Navy.

The Winegar Piano Corp., Columbia and Brunswick dealers, have altered their store. A new balcony, in which the business office is located, is among the improvements.

John Schuler, Sonora dealer, is a war garden enthusiast. He has a large farm under cultivation on Ellicott Creek, N. Y.

"Keep your hammer in your pocket" is the slogan of a local talking machine dealer. This merchant says he is determined not to lose sight of his early training in trade ethics, even during the stiff competition of wartime. He says "stabbing the other fellow in the back" by knocking his goods may help "put over" a sale now and then, but that it eventually spells failure.

Buffalo talking machine dealers who have covered Cattaraugus county this summer say this is a rich field for business. The farmers there are making plenty of money from their dairy farms and well-cultivated gardens.

C. A. Gifford has joined the sales force of W. Howard Webb, at 150 East Genesee street.

L. B. Adams, dealer in the Main Arcade Building, lives at Crystal Beach during the summer. Like hundreds of other local business men, he finds that the lake ride to and from business during the hot weather is a health builder.

MILITARY GRAFONOLA TRUNK

The dealer service department of the Columbia Graphophone Co., New York, announced this week the addition to the Columbia line of a military Grafonola trunk designed to accommodate the type "C" Grafonola. This trunk conforms in every respect to those already announced, and will doubtless be a welcome addition to the portable Grafonola line. These military Grafonola trunks, which were placed on the market several months ago, have enjoyed great popularity with vacationists. Men in the service and travelers use these trunks to excellent advantage, and Columbia dealers report an active demand for this product.

Some men who have climbed to the top rung of the Ladder of Success don't dare look down at their less fortunate fellows for fear they'll lose their own hold.

Manufacturers—Jobbers—Dealers

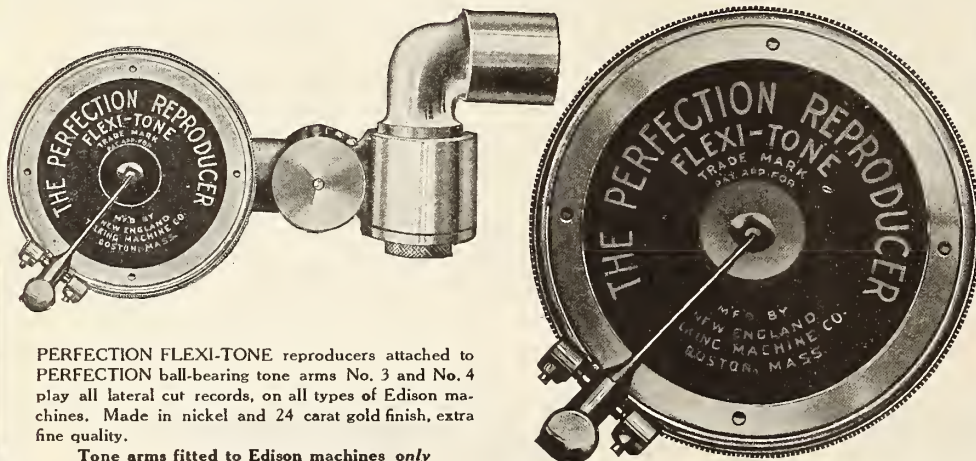

PERFECTION FLEXI-TONE reproducers attached to PERFECTION ball-bearing tone arms No. 3 and No. 4 play all lateral cut records, on all types of Edison machines. Made in nickel and 24 carat gold finish, extra fine quality.

Tone arms fitted to Edison machines only

PERFECTION FLEXI-TONE reproducers No. 3, No. 6 and No. 7 fit all types of Victor and Columbia machines. Made in nickel and 24 carat gold finish.

The only way that you can appreciate the value of this product is to have these arms and reproducers in your stock. The PERFECTION tone arms, and FLEXI-TONE reproducers are INCOMPARABLE, as the product is the very highest grade that can be manufactured. These reproducers and arms are built with the precision of a watch, carefully assembled, best of material is used, and plate is of the finest. Your customer WILL BUY a first-class tone arm, and he demands the best reproducer, for nine times out of ten, he wants and will pay for the best. Your profit is greater when you sell high grade accessories, so it is up to you to investigate the real value of this product, and if you do, you will quickly place your order for a quantity. If your jobber does not stock this product, write direct for prices, etc.

Phono. Mfrs. { Send for detailed information regarding our new Universal Tone Arm Models 9 and 10 with new Puritone Reproducers. They reproduce all makes of records with perfect amplification of sound

All accessories in stock ready for immediate shipment. Write for prices, information, etc.

NEW ENGLAND TALKING MACHINE CO.
16-18 Beach Street BOSTON, MASS.



HARVEST TIME IS HERE

YOUR sales floor should be filled to its capacity with NIGHTINGALES. The most popular line offered to-day. Our factory is running full speed to meet the demands. Dealers enjoy handling the NIGHTINGALE because it sells quickly and gives the customer *Perfect Satisfaction*.

PLAYS ALL RECORDS

You will remark its clear tone. The beautiful high notes of Galli Curci and McCormack are not shattered and lost in our tone arm.

The NIGHTINGALE is built in our own factory under the strictest supervision. Skilled hands are employed behind which is the power of *knowledge*. Equipped with Stephenson's Precision-Made Motor and the Scotford Tone Arm and Reproducer gives the dealer a *Superb* instrument. Prices from \$90 to \$150.

Your complimentary order is solicited, the result of which we know will be lasting friendship.

Get in touch with us at once regarding your needs for the coming season. Your inquiry will receive our very best attention and the *Highest Service* guaranteed.

Harry B. Wolfer
President

Nightingale Mfg. Co.
422-426 North Armour St., Chicago, Ill.

CABINETS

It makes no difference whether you are a

**Manufacturer,
Jobber or
Dealer**

You can use our line to bring money into your pockets during the fall season ahead.

CABINETS

for the jobber fully equipped with the most modern and best accessories obtainable. Your own name on the machine if you desire.

CABINETS

for the manufacturer. Cabinets that are the results of our long years of furniture building—in a variety of handsome designs.

CABINETS

that will sell themselves through their attractiveness. Send for catalogue and information.

**THIS IS AN AGE OF
SPECIALIZATION—**

**FOR CABINETS GO TO
THE CABINET
BUILDER**

For the dealer we have the **HARPONOLA**, a phonograph built by us and of exceptional merit.

The Celina Furniture Co.
CELINA OHIO

MINNEAPOLIS DEALERS MAY ORGANIZE LOCAL ASSOCIATION

Many Objects Will Be Gained by So Doing—Dealers Look for Record-Breaking Trade This Fall
—Great Prosperity Prevails in Northwest—Dealers Now Enlarging Their Lines

MINNEAPOLIS and ST. PAUL, MINN., August 7.—Dealers in talking machines and like musical devices, whatever they may be called, are prepared to take all the machines that the dealers will forward to them, for, like the farmers, they are assured of a monumental, a record-breaking fall. It will be a month before industry and trade will be up on "high," but already the talking machine dealers are complaining that they are unable to get goods and the jobbing houses, which are supposed to supply goods, are like Mother Hubbard's cupboard, while their managers are at the end of their wits.

Many retailers in this section are more than discontented and there is a disposition on the part of many to broaden out their lines so as to have more than one string to their business bow. Foster & Waldo and the New England Furniture Co. carry three lines of talking machines, the Victor, Edison and Columbia, and some other dealers have two.

There is a possibility that the talking machine dealers of Minneapolis may form a local association for the protection of their mutual interests. They have gotten together informally on one or two matters in the past and they find that there is need for a permanent association. It could accomplish much good for the craft in the way of standardizing terms for payments and other purely business details.

Jay H. Wheeler, who handles the Pathé instruments and records in the Northwest, is seeking a large stock of the \$75, \$100 and \$110 instruments for the fall trade. The medium-priced styles, he states, are disappearing so rapidly already that he has been unable to assemble what he considers a safe reserve. Of the high-priced and low-priced styles, the Sommers stock is well supplied and the raid from the rural customers is awaited with equanimity. The house claims the largest stock of records in the Northwest.

Being within a night's ride of the Dubuque factory of the Brunswick-Balke-Collender Co. and with E. L. Kern, one of the directors of the company, the Northwestern headquarters for the Brunswick machines will not be shy of instruments or supplies within the next few months. A goodly stock already has been assembled and traveling men are placing orders in every direction. Boutell Brothers, Minneapolis, will make a big drive with the Brunswick line in the near future. G. F. Gamble, for years a Brunswick traveler and widely known in the Northwest, has been made manager of the house's phonograph department and has selected an efficient staff. Costin Brothers, Huron, S. D.; Home Furniture Co., Sioux Falls, S. D.; Hagen-Newton Co., Fargo; R. B. Griffith, Grand Forks; Hart Swalstead, Minot, and other dealers have launched a big Brunswick campaign. The Hagen-Newton Co. started at the North Dakota fair a fortnight ago, and showed there a fine booth of Brunswicks.

Laurence H. Lucker left Saturday, August 3, for New York and New Jersey to get an adequate supply of Edison instruments. He thought that he had things well in hand, but a 100 per cent. increase in the number of orders from the rural dealers has completely spilled the beans. Something must be done instanter, and Mr. Lucker will strain every energy to get more Edisons. The retail sales in St. Paul and Minneapolis are running about as expected—somewhat heavier than a year ago, but not remarkably increased. The Minnesota Phonograph Co. is seriously hampered by the loss of salesmen through the war draft. It happened that nearly all the "live wires" among the sales force were of draft age and, as they could not be replaced by men, the managements had to use women. Of course, the latter are all right, after they learn the business, but in the meantime they don't know it.

Local dealers handling the Victor say that

there will be a record sale of Victors in the Northwest next fall provided the instruments can be obtained even appreciably in proportion to the demand.

ANNOUNCE NEW LINE OF MACHINES

Veritone Talking Machine Co. Plans for Country-Wide Distribution of Products

The Veritone Talking Machine Co., 145 West Forty-fifth street, New York, announce in this month's Talking Machine World their fall line of talking machines. The above company have in the past confined their efforts to the production of cabinets, having had contracts for the delivery of cabinets to several large companies. Early this year they also decided to place in addition a machine of their own on the market and during this period they have gained many agencies in the Metropolitan district. Now, having increased their production, they feel they are prepared to make their product nationally known. They are manufacturing six models ranging from the table cabinet machine at \$50 up to the more elaborate model at \$215. The sales management of the firm is in the hands of men who have long been connected with the piano and talking machine trade and they state they are in a position to give the dealer a proposition that will be interesting.

AVOID MICROBE OF DRY ROT

Business dry rot is a microbe, active, healthy, formidable, pernicious, and flourishes in all climates and under all conditions. As soon as it gets into one's system, office or work shop, its influence is immediately felt. Its victim is plainly marked for life unless heroic treatment is promptly prescribed, and rigorously followed up.

BROOKS AUTOMATIC REPEATING PHONOGRAPH



THE WONDER INSTRUMENT

Plays and repeats any kind or size record—any desired number of times—then stops automatically with the tone arm suspended off to the right in the air. Any child can operate it.

WONDERFUL TONE WONDERFUL FINISH
WONDERFUL IN ITS SIMPLICITY

The Machine Creates Interest and Discussion.
It is Self-Advertising

WONDERFUL SELLER

DEALERS—Send for Particulars, Prices, Terms.

BROOKS MFG. CO., Saginaw, Mich.

VAN VEEN "BED-SET" BOOTHS



An adequate booth equipment will mean increased record business during the holiday season

WRITE FOR A COPY OF OUR NEW CATALOG

Van Veen "Bed Set" Sectional Booths can be erected as easily as a bed (no skilled labor required). Booths shipped on short notice *anywhere*. Room sizes any multiple of 3 feet. High grade finish, will match your sample if desired. Sound-proof construction. We design and build complete interiors. We also build record racks, which are described in our new catalog.

Arthur L. Van Veen & Co. 47 West 34th Street, New York
TELEPHONE - - - GREELEY 4749

HOPKINS TALKS ON ADVERTISING

General Sales Manager of Columbia Co. a Prominent Figure at Convention of Associated Advertising Clubs of the World—Discusses Trade Conditions on the Pacific Coast

George W. Hopkins, general sales manager of the Columbia Graphophone Co., New York, returned to his desk last week after a month's trip to the Pacific Coast. While in the West Mr. Hopkins attended the fourteenth annual convention of the Associated Advertising Clubs of the World. During the course of this convention Mr. Hopkins was re-elected a vice-president of this well-known organization; his re-election being a tribute to the splendid work which he has performed in the interests of the association for many years.

During the course of this convention Mr. Hopkins gave several addresses, one of which was entitled "Standardized Merchandise—Now and After the War." This address, which was one of the most important given at the convention, was reprinted by many newspapers and trade periodicals, who proclaimed it as an address well worth the careful attention of merchandising and advertising men in all lines of the industrial world. In this address Mr. Hopkins urged advertising men to study and combat the vicious theory that bulk goods are the most economical, and set forth logical arguments that won the hearty applause of his auditors.

"Selling Merchandise to Women" was the topic of Mr. Hopkins' talk before the Women's Division of the Associated Advertising Clubs, and this address was also reprinted in various forms throughout the country. Before the Junior Advertisers' Club conference Mr. Hopkins spoke on the "Fundamentals of Salesmanship," saying in part: "A green salesman can sell goods sometimes—a blue salesman never. Optimism is the foundation for enthusiasm in selling goods. The average merchant buys discounts rather than looking upon the goods as an opportunity to resell at a profit. And the

wise salesman is the man who shows the dealer that he is offering to sell him profits. 'No' is the first word of the buyer. The salesman needs to keep a pencil in the hands of the buyer and make him a part of the demonstration—make him a part of the selling operation, and first of all, the salesman must 'sell himself.'"

While on this trip Mr. Hopkins called at the Columbia branches in Los Angeles, San Francisco, Seattle, Portland, Salt Lake City and Denver, and was enthusiastically received by Columbia branch managers everywhere. In fact, in each one of these cities, Mr. Hopkins was the guest of honor at informal luncheons and meetings, where he had an opportunity of discussing various problems with Columbia dealers. During the course of these meetings Mr. Hopkins spoke on pertinent and timely subjects, and his talks were enthusiastically received in every city.

In a chat with The World Mr. Hopkins commented as follows upon business conditions on the Pacific Coast: "The business situation in the far West is simply wonderful, due very largely to shipping activities that are general on the Pacific Coast. Los Angeles, San Francisco, Portland and Seattle are all sharing in this prosperity, which, from all indications will continue for a long time to come.

"Columbia dealers in this part of the country are closing a record-breaking business, and wherever I visited our representatives informed me that their Columbia sales were limited only by the available merchandise. They are achieving high-water sales totals, and are all making preparations for a banner fall business.

"Columbia representatives are enthusiastic regarding our new product, and are particularly gratified with the non-set automatic stop, which they believe offers them a most valuable selling

argument. Record sales this summer are exceeding the average sales totals of the winter months, and I was glad to observe that practically all Columbia dealers have adopted merchandising policies that enable them to conduct their business on a sound substantial basis, and show gratifying profits in the face of abnormal conditions."

THE EDISON IN FRANCE

Wisconsin Dealer Received Letter Telling How the Soldiers Appreciate Their Machine

Will Bardeen, Edison dealer at Edgerton, Wis., is quite proud of the Army and Navy model the Edgerton boys took along with them to France several months ago. Here is an excerpt from a letter Mr. Bardeen received from "over there" a few weeks ago:

"We are just playing the old Edison, and I want to tell you this is the best ad you ever got hold of. Our old Edison sure has seen some grief, more, probably, than you can imagine. It has been thrown around in freight cars and handled like an old dry goods box, and if you knew how they handle freight on those transports you would wonder that we had any machine left. I saw it once after we landed, on a box car among a bunch of boxes, and the last time I saw it before we got to this place was on a motor truck with a few more articles of war on top of it, such as army stoves, etc. After all this, it is now standing a few feet from me playing the 'Stars and Stripes Forever,' and two or three of the fellows are dancing their soles thin on the bottom. I'll wager the machine is just as good as it was the day we bought it."

WANTS TALKERS FOR AUSTRALIA

Arthur Haskew, of Toowoomba, Wants to Hear From Talking Machine Manufacturers and Others Regarding Agency for That Country

The World is in receipt of a letter from Arthur Haskew, Margaret street, Toowoomba, Queensland, Australia, who is desirous of making a connection with player-piano and talking machine manufacturers with the idea of taking agencies after the war. Mr. Haskew also states he contemplates making a trip to this country in the near future.

FINAL MEETING OF FRAAD CREDITORS

The final meeting of the creditors of the Fraad Talking Machine Co., bankrupt, was held at the office of the referee in bankruptcy, Harold P. Coffin, at 82 Beaver street, New York, on July 26th, when the final accounting and vouchers of the trustee in bankruptcy, Chas. A. Ogran, were inspected and passed upon. It was also decided to declare a final dividend, provided the funds were in hand to meet the claims filed.

VICTROLAS FOR SIGNAL CORPS

The spruce division of the United States Signal Corps recently placed an order with the Wiley B. Allen Co., of Portland, Ore., for ten Victor Victrolas.

The Electric Phonograph Co., Kalamazoo, Mich., which recently entered the talking machine field, is expected to turn out its first machine on or about August 15.



Geo. W. Hopkins

THE REGINAPHONE

A phonograph of the highest grade with many exclusive features. The new Regina Sound-box is the greatest improvement in talking machines in years, reproducing all hill and dale and lateral cut records equally well, and in a manner unsurpassed.



Territory arrangements with active dealers. Send for particulars.

THE REGINA CO. 47 West 34th Street, NEW YORK
209 S. Wabash Ave., CHICAGO, ILL.

Manufacturers of the Regina Music Box and other musical instruments for over 25 years.



A 12-inch double. On one side—the most faithful reproduction of instrumental tone qualities ever heard on a record. On the other—a marvelous recording of a male quartet.

Can You Sell— a \$1.25 Record at 25 cents?

That is just what you now have
the chance to sell in the new



“Special” Records

Can be played on all makes
of Talking Machines

Now you see why the price of the Pathé “Special” Record is 25c.—to start owners of other phonographs buying Pathé Records *regularly*. The Records of such great operatic stars as Muratore, Muzio, Didur and a host of others—most of them singing for Pathé Records exclusively. The Records of the old world music, celebrated European Orchestras, on Pathé Records only. The latest popular hits, *first* out on *Pathé*.

How many will you start with?

You can just as easily, just as quickly, sell twice that number.

Hear the Great French Tenor
MURATORE



This famous Chicago Opera Company
Artist sings *exclusively* for *Pathé* Records

Pathé Frères Phonograph Company

20 Grand Avenue

Brooklyn, New York

The Pathé Frères Phonograph Co. of Canada, Ltd., Toronto

An Eye for Beauty —everybody has it

That is why so many stop,
look and ask to hear



Art Model Phonographs

And the *surprisingly* low price together with the superb Pathe Tone do the rest.

Don't overlook this opportunity to make bigger, more profitable sales.

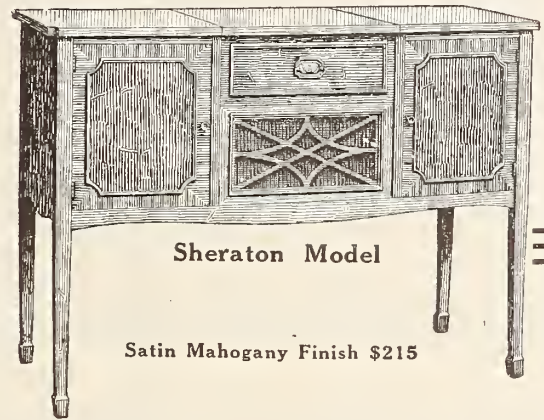

Sheraton Model

Satin Mahogany Finish \$215

No Needles to Change
The Pathé Sapphire Ball takes the place of needles. It need never be changed.

Long Life to Records
The Pathé Sapphire Ball cannot possibly cut, grind, rip or mar the record's surface.

The Pathé Controla
With the Pathé Controla you may increase or decrease the tonal volume of the Pathé Phonograph at will.

Plays All Records
Each Pathé Phonograph plays not only Pathé Records, but all other makes of records, and plays them perfectly.

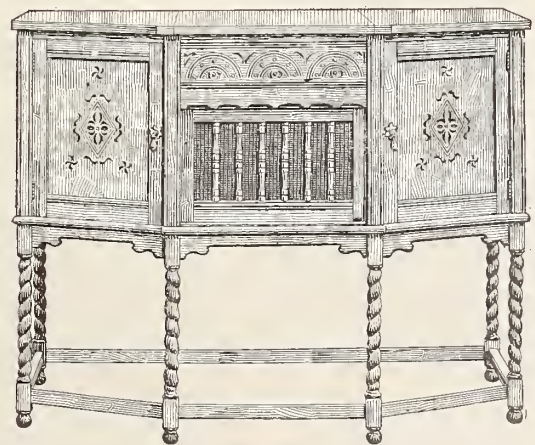

Jacobean

Antique Fumed Oak Finish \$215

Pathé Frères Phonograph Company

20 Grand Avenue

Brooklyn, New York

The Pathé Frères Phonograph Co. of Canada, Ltd., Toronto

CONDITIONS IN ST. LOUIS TRADE

Business Limited Only by Stocks Available—Country Trade Very Active—Sabath Succeeds Magoon as Manager of the Kieselhorst Department—Clever Record Ads—Other News

St. Louis, Mo., August 6.—The talking machine business in this district is limited only by the stocks available. If there is a dealer, large or small, who is satisfied with his supply of machines and records, the writer has not found him. Jobbers are especially worried about the division of their receipts. Some of the retailers say that they have enough of machines except of a few favored models and that they probably did as much business as was possible with the help available, but they always add "we just got by and we are wondering how we will get by next month." Some dealers are going easy on sales and letting some stock accumulate for later buying.

There is method in this system, if their idea of the future is correct. They reason that the

MICA

BEAUTIFUL COLOR
DIAPHRAGMS OF BEAUTY
INTERNATIONAL MICA COMPANY

Offices and Factory, 37th and Brandywine Streets, WEST PHILADELPHIA, PA.

supply of machines from the factories will get smaller before it gets larger and that the demand from the people is going to continue, so that after a while they will be able to sell any accumulated stock. To rush sales just now would be to add to overhead, while by keeping the machines for a few weeks only storage space rental can be charged, and this charge will be less than man power charge for hunting a prospect for the sale.

But a number of dealers, and there are many of them, are pushing sales as far as they can, cleaning up on all stock in sight. Some of these dealers believe that stock limitations will be extended soon and others go on the theory that the only use for merchandise is to sell it as quickly as possible.

Possibly the most urgent demand for machines comes from the country districts. Generally speaking, crops are excellent in this trade district and there never was a time when any produce could be turned into money as quickly as this year. Also the price on so many articles for sale on farms is stabilized that there is no need for holding back. So the country dealers are expecting a rush of trade. Some are having it already and the dealers are coming to town to beg for stock. They are told that they are getting a full share and that all machines arriving will be apportioned to the trade as soon as possible.

A variation in the monthly list advertising was supplied August 1 by the Famous & Barr Co., who plunged in the advertising of one particular record in the list as follows:

"We've been waiting for some time to tell you about one particular number of the August list. You'll like it just as much as we like it and you will become just as enthusiastic about it as we did when we first heard it. The title of the selection is:

SMILES

Double-Face Record No. 18473—"Smiles," Fox-Trot and Rose Room Fox-Trot—85c

This is undoubtedly one of the best dance records the Victor Co. has ever issued. It is played in fox-trot time by Joseph Smith's orchestra with a new arrangement that will surprise you. "Smiles" was composed by Lee S. Roberts and already has created a big hit in New York.

"The first day response to this advertisement was pleasing."

J. B. Sabath, assistant manager of the talking machine department of the Kieselhorst Piano Co. for several months, has been made manager in the place of A. M. Magoon, who goes to the Dayton Drygoods Co., Minneapolis, his former home. An interesting story is told as to how Manager Sabath comes to be in the Kieselhorst service. Mr. Sabath came to St. Louis from the East last October and was in town a day or two before he applied for a job, then he went to Kieselhorst. It happened that the day he applied E. A. Kieselhorst, the president of the company, had started East on an extended trip. None of those in charge felt that they had the authority to employ him, as the question had not been discussed. He was told, after some talk, that they would like to have him, but the man who did the employing was gone. "Well, I'll wait until he comes back," said Mr. Sabath. "I have looked over the talking machine stores in town and have looked up the advertising and have picked this as the place I want to work, and I will wait."

So Mr. Sabath went to the I. C. C. and got a temporary job until E. A. Kieselhorst returned. Then he went in and discussed the case with him and went on the payroll. Now he is advanced.

Manager Guttenberger, of the Vocalion department at Aeolian Hall, reports an increased machine business to the limit of the stock available and a 20 per cent. increase of record business. "We are doing all the business we can," said Mr. Guttenberger, "and our prospects appear excellent to us. Our only concern now is stock. If the factory is able to continue shipments we anticipate a very fine fall business, both in jobbing and retail."

E. C. Rauth, of the Koerber-Brenner Music Co., Victor distributors, and J. F. Ditzell, manager of the Famous & Barr talking machine department, the only exclusive Victor department downtown, made a motor trip to Michigan last month with their wives. They enjoyed ten days at a lake resort north of Muskegon, where there was nothing to do but sleep and eat and talk of talking machines. They had a good time.

J. F. Ditzell left August 1 for New York, to be gone for two weeks on business connected with the piano end of his department.

The Veritone Phonograph and A Dealer's Proposition

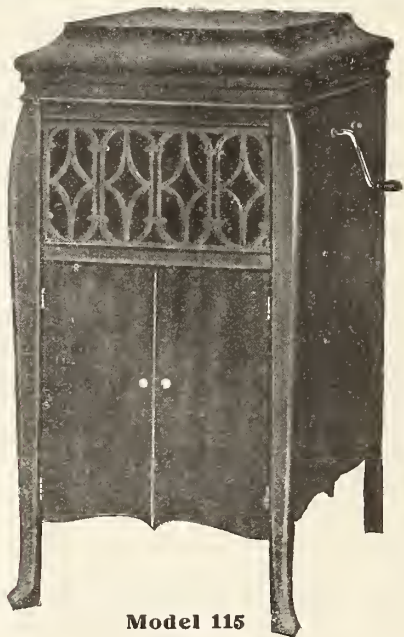

Model 115

The Veritone Phonograph is not only mechanically efficient and artistic in appearance but it assures the dealer a large margin of profit.

Built in six styles retailing from \$55.00 to \$215.00, it plays all makes of disc records and is equipped with many individual features.

TO RESPONSIBLE DEALERS

We know you are looking for a phonograph of quality combined with a profitable proposition. In order to prove to you that we have the best you have yet seen we will send you one of our machines on approval. Let us know where to send it.

VERITONE TALKING MACHINE CO.

145 West 45th Street, New York

How Intelligent Use of Manufacturers' Co-Operation Can Help Retail Trade :: By G. D. Crain, Jr.

Manufacturers know that their success lies in doing business with successful merchants. It is impossible for a manufacturer to make money unless the merchants with whom he is dealing are likewise making money.

That is why everybody in the organization of a manufacturing concern, from the president down, and with special emphasis on the traveling men, is anxious to give every possible assistance to those who are distributing their goods.

Many merchants make use of co-operation which emanates from the manufacturers, appreciating it at its full value, and realizing that while they have something to gain, the dealers themselves will profit most.

Others think that because the suggestions come from the manufacturer, the latter has "an ax to grind," and that they can best serve their own interests by disregarding these offers of friendly assistance.

I know a merchant who owes his present strong position to the aid that has been given him by traveling men. He said not long ago that on one occasion a tip from a salesman regarding a sharp rise in the price of goods enabled him to save many hundreds of dollars on a single purchase.

This merchant gives the glad hand to every traveling man who comes into his store, because he appreciates the fact that each of these visitors can, if he desires to do so, be of very definite assistance to him.

He doesn't buy of every salesman, of course; but he makes each caller feel that he got all of the consideration that he was entitled to, and each salesman becomes a booster for that merchant and that store. Isn't it worth while to have a bunch of friends like that?

Traveling salesmen keep their eyes open, as a rule, and see the good and bad points of the stores that they visit. The merchant who shows that he wants to get ideas regarding the management of his business, including the display of the merchandise, the training of salesmen, etc., will get all sorts of suggestions from the travelers, many of them of direct application to his business. These suggestions are worth money.

As indicated, the traveling man knows the markets in his own particular line, and is often in a position to give the buyer for the retail store some particularly good advice on this sub-

ject. The merchant who voluntarily closes his ears to information of this character is overlooking a big bet. He is making it just a little harder than necessary for him to buy right, and buying right is just about half the battle in the successful conduct of a retail establishment.

There are other forms of co-operation extended by the manufacturer. Most of them have what are known among advertising men as "dealer helps." These consist of window dis-

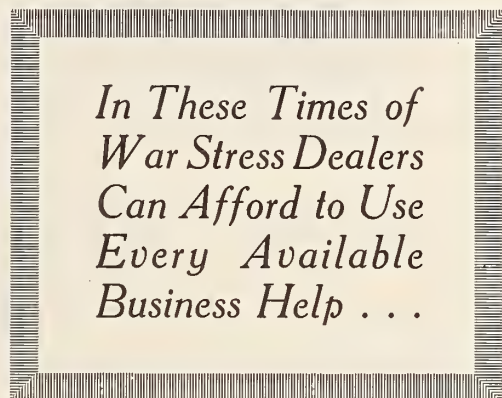

play material, store cards and other advertising matter, the use of which helps to create a demand in the store for the products of the manufacturer.

The dealer can logically argue that the use of this material benefits the manufacturer, because the brand of his product is shown on the cards, etc. But after the merchant has put the goods into stock they are his goods, and he is more concerned than anybody else, even the manufacturer, in disposing of them.

The interest of the producer is in getting the merchandise out of the store, so as to make way for additional goods. To that extent the interests of the merchant and the manufacturer are identical. That is why the retailer is justified in using every bit of advertising matter that comes to him, providing it is calculated to increase the interest of his customers in those particular goods.

Another angle on this proposition is that many of the articles carried by the dealer are likely to be advertised by the manufacturer. The latter is probably spending money to acquaint the public with the merits of his product.

The customer who has seen the manufacturer's advertising, and then sees the announcements in the store window or inside the store, connects the two, and whatever influence the manufacturer's advertising may have had thus reacts to the benefit of the dealer.

Furthermore, most stores are short-handed at present. The sale that is made with the least effort is the profitable, worth-while sale. The use of display matter helps to force a decision by the customer, so that instead of asking to be shown an assortment of goods, a particular product is called for. To that extent the utilization of the manufacturer's advertising helps is a benefit in bringing about sales in a shorter time and with less effort.

Some of the manufacturers have dealers' service bureaus, which take up specifically the inquiries that their distributors send to them with reference to retail merchandising questions. Often these bureaus can outline methods of handling the goods that will bring better results than have been experienced heretofore. The merchant is therefore justified in making use of any co-operation of this character.

The writer knows of one house that sends out a monthly bulletin to its dealers, showing methods of promoting its goods during the current month. Apparently this is an entirely selfish move, and, of course, use of the methods will increase sales of these goods. Yet the dealers frequently make use of the selling plans contained in the bulletins, because it is profitable.

The merchant, in these times of war stress, can afford to use every available help. It will be an advantage to him to use the salesman and use the house, and to avail himself of the advertising and display material which the manufacturers offer. He can be his own judge of what is best suited for use in his store and in his community, but he ought at least to pass judgment on the sales promotion matter that the houses supplying his merchandise can furnish. (Copyright, 1918, by G. D. Crain, Jr.)

SETTLES WITH CREDITORS

The Cathedral Chime Co., Inc., of 106 Reade street, New York, which recently became involved in financial difficulties, has made a composition with creditors on a 20 per cent. cash basis. The liabilities were \$35,800, and the assets \$9,462.



Reproducer

The New Phonograph

Phon d'Amour

The New Wonder

Our patented diaphragm and reproducer give that clean, clear, snappy, mellow tone. There is no mushiness, no sharp or tinny sound. Our reproducer is suited for every purpose. It is adapted for brass band, popular song work, for violin and piano solos and for operatic sopranos, taking the high notes with such clearness and distinctness that it is the marvel of musicians and singers of renown.



Copyright, 1917, by The Fritsch Phonograph Co. Trade Mark

THE FRITZSCH PHONOGRAPH COMPANY

228-230 West 7th Street

CINCINNATI, OHIO



HENRY BURR
Second Tenor

Reckoned among the foremost ballad singers of the age, a worthy rival of McCormack with a voice sweet and clear.



ARTHUR COLLINS,
Baritone

When you hear him you enjoy it, and cry for more.



BILLY MURRAY
Tenor and Comedian

William, with that grin? Never. He's just Billy Murray as known everywhere. The audience does not get enough of him.

POPULAR RECORD MAKERS

Now Booking Concerts for Fall and Winter

Appearing in Person

Henry Burr—Billy Murray—Arthur Collins—Byron G. Harlan—Albert Campbell—John Meyer—Fred Van Eps—Theo. Morse—Sterling Trio—Peerless Quartette

With a Repertoire of Old-Time Favorites and the latest popular comic and sentimental hits, records of which will be produced by the various talking machine companies this season.

Jobbers and Dealers

Make arrangements now to give your record buyers an opportunity to see and hear these famous artists.

There is no second company or connection with any other troupe of record makers.

Write for Particulars

H. H. McCLASKEY, Mgr.

102 West 38th Street

New York City

WHAT THE NEWSPAPERS SAY OF US:

"The record makers have come and gone leaving pleasing memories in the hearts of the large audience at the Victoria last night, and they vote them peerless entertainers."

"The great audience came fully expecting to be royally entertained and their expectations were fully realized. Every number on the program was a popular gem."

"With a chorus composed of 'stars' it would be difficult to make comparisons between them. Each one is a genuine artist and each more than sustained his reputation."

"It was worth a hundred dollars to my father to hear Henry Burr sing 'Just a Baby's Prayer at Twilight.'"

"A high-class concert was expected from such artists but expectations were more than realized."



BYRON G. HARLAN
Tenor

A name so familiar that it is like speaking of one's own household.



ALBERT CAMPBELL
First Tenor

A lyric tenor with a voice that threads way up above, silvery and clear and true.



JOHN H. MEYER
Basso

His voice is one of the most opulent color. It fairly glows with warmth, and is altogether delightful.



FRED VAN EPS
Banjoist

A wizard at the banjo, without a peer.



THEODORE MORSE
Pianist

A composer and accompanist who is a genius. Composer of "Mother," "Blue Bell," "Dear Old Girl," etc.

CINCINNATI TRADE SUFFERING FROM SHIPPING EMBARGOES

Need for Organization to Offset Effect on Trade—Columbia Dealers' Get-Together Meeting—Dealers Advised to Place All Orders for Fall as Early as Possible to Avoid Delay

CINCINNATI, O., August 2.—Manufacturers and shippers, the latter taking in the jobbers, are learning a real lesson in the lack of organization work about Cincinnati so far as this concerns adequate terminal facilities.

Cincinnati, it is believed, is the worst town from an embargo standpoint in the country. This condition has struck home with telling effect on dealers in talking machines. Factories simply are unable to make any shipments into the Cincinnati district. The embargo on unnecessary freight is on and off all the time so that the shipper has reached a stage where he believes the outlook to be hopeless.

The Phonograph Co., for instance, has the lowest stock for this time of the year since the opening of the Cincinnati branch. There is a fair supply of machines at the Chicago warehouse, but these cannot be shipped into the Cincinnati yards. The Baldwin Co., taking another example, finds some of its best dealers in Pennsylvania being compelled to buy from Eastern houses because of the inability of the corporation to ship out of this city. The Phonograph Co. also claims that the dealers, warned by the shortage of cars of last winter, have stocked up in advance of their usual time.

The Tucker Talking Machine Co., Sidney, O., will soon place a finished article on the market. Five models are now being prepared. The machines would have been announced sooner than this but for the death of J. B. Tucker, president of the Tucker Wood Works, of Sidney, who died early in July. The talking machine department's head is Karl Hodge.

"Don't wait for future deliveries" is the edict of C. W. Neumeister, representative of Otto Heineman Phonograph Supply Co., in talking to manufacturers and dealers whose supplies are running low.

The big thing of the past month was the Columbia dealers' "get-together" meeting. Dealers from all over the Cincinnati territory came together for a one-day convention, as it were, Monday, July 29. The meeting was held at Columbia Graphophone Co. headquarters, 427 West Fourth street, this city. More than seventy-five dealers were represented at the meeting, and all were quite enthusiastic over the result. Many of them requested another such meeting in the fall, but Manager Dawson has not indicated that another one would be held so soon.

The meeting was opened by F. F. Dawson, local manager of the Columbia Co., with an address which was received with hearty applause. Among other things Mr. Dawson said: "I want to plead with you dealers, the majority of whom have other large interests aside from your Columbia department, to make your Columbia department a positive part of your business interest. I want to cause you to awaken to the possibility tied up in the corner of your store set apart for the home of Columbia. The Columbia line is your greatest business builder. You can sell Grafonolas to a hungry public and satisfy their hunger for a time, only to find that soon their appetite is greater than ever. Columbia records to suit the taste ready to serve will build a business worthy of our greatest ambitions. This system of new records every month keeps the old instrument a matter of new interest. Make this department a positive part of your program. It has been negative long enough."

The address of Assistant General Sales Manager F. K. Pennington, of New York, was the chief address of the meeting and created great interest and strengthened the confidence of the dealers in the Columbia line and their purposes. Mr. Pennington is always a welcome visitor to the Cincinnati territory. He gives to his work a wholesouled earnestness that makes his presence strongly felt, and a wholesome influence is always left behind.

The Columbia Graphophone Co. have just

closed the best month in the history of the local branch.

P. H. Oelman, manager of the Phonograph Co., is looking forward to a series of tone test recitals in his district in October. Harold L. Lyman, of Thomas A. Edison, Inc., was in the city during the past week arranging for the route. The artists will be Marie Tiffany, of the Metropolitan Opera Co., and Glen Ellison.

The Crystola Co. is just putting into the mails a new folder, favoring Style T, price \$250. It is a high example of printing in colors.

The talking machine department of the Rudolph Wurlitzer Co. has taken over more floor space of the Wurlitzer Building. This time the additional space is being utilized entirely for office purposes. The rooms which are located on the third floor of the Wurlitzer Building are for exclusively wholesale purposes only. The

previous offices of the talking machine department proved to be inadequate to entertain the large number of dealers visiting the Wurlitzer department and the new quarters were picked out with an especial view toward providing every facility for the visiting dealers to transact their business to the best advantage.

Conditions have not changed very much in the Cincinnati territory, excepting that the record demand has increased and also the Victrola sales. Fortunately, the demand in Victrolas is running heavily towards the higher-priced machines and this is very fortunate, as it enables the dealers to make quite a few sales without the embarrassment which would follow if the demand ran too heavily toward the medium-priced instruments.

There is still a very big reserve stock of records to be had and also both cheap and high-priced Victrolas. With this stock available, there is no reason why the present shortage should not be successfully weathered and things kept moving, until factory shipments will again be normal.

BRUNO

Criterion

(Full Tone)

and

Mezzo-Tone

(Medium Tone)

Steel

NEEDLES

A Superior Quality of
Reliable American Manufacture

**These *Needles* have been our
Standard for many years**

If you desire samples, please
use the coupon below

C. BRUNO & SON, Inc.

(Established 1834)

Wholesale Exclusively

351-353 Fourth Avenue NEW YORK

C. BRUNO & SON, Inc.
351-353 Fourth Ave., N. Y. City

Please send samples of Criterion and Mezzo-Tone Needles.

I am in the market for a quantity of.....
thousand Needles.

Name

Town

State

ATLANTA SALES EQUAL JANUARY

Business Is of Unprecedented Proportions Throughout the South—Leading Houses in Atlanta Make Most Interesting Reports of Progress—Face Problems With Equanimity

ATLANTA, GA., August 6, 1918.—Trade conditions in the talking machine business in Atlanta during July were the best since January, which is always a large month.

Your correspondent called at the local store of the Cable Piano Co. recently and was surprised at the volume of sales posted on the bulletin board for the first and second salesmen. He would not have believed that such a very large volume of business was moving except for the undeniable assurance that the figures were authentic. The sales of the leading salesman were creditable for the entire business for a month of a whole store, and those of the next highest would not have been sneered at. The Cable Company are possibly the largest Victor dealers in the South, and their organization is always keyed to the top note of efficiency.

I. M. & R. D. Bame, Victor and Sonora dealers, say that their business up to the middle of July was ahead of the entire month of June, and their entire July business was equal to anything this year. Their cash sales are large, first payments and monthly terms good, and cash record business was never better.

Phillips & Crew Piano Co., the oldest Victor

WALTER S. GRAY
San Francisco
Chronicle Bldg.

**Pacific Coast Jobber
for the Best in Talking
Machine Trade Accessories**

NEEDLES

dealers in Georgia, report a most satisfactory business. The usual mid-summer dullness has not materialized, and if anything, business has grown better and increased in volume as the summer lengthened. This concern is putting forth some very high class advertising in the local papers and is reaping the benefit of their foresight.

Chamberlin-Johnson-DuBose Co., Victor and Sonora dealers, have become completely rejuvenated. Under the experienced and efficient management of Edward Brotherton, and a fine system of show windows and advertising they have quadrupled their sales in less than six months, and are moving steadily ahead to new fields of endeavor and success.

The Atlanta Talking Machine Co., Columbia and Vocalion dealers, report the sale of a period

design Grafonola to one of the leading families of the city, also a large record shipment to the naval station at Guantanamo Bay, Cuba. It speaks well for the service of this concern that they should be favored with orders for Columbia records from such a prominent customer.

Phonographs, Inc., Edison jobbers and retailers, have just had their retail store remodeled and are in better position than ever to serve the public. Their sales have held up finely all the first half of 1918, and the Edison has undoubtedly found a "home" for itself in Atlanta and vicinity.

Haverty Furniture Co., Columbia and Pathé dealers, report that their business the first half of July was larger than all June, and the month of July was the best of 1918, surpassing January, which was in itself a very fine month. The backbone of what seems to have been a period of uncertainty and dullness in the month of June is entirely broken, and dealers generally look for continued good business during the balance of 1918.

Zaban Furniture Co., Columbia dealers, state that their July business was entirely satisfactory, and that they have found the Columbia line a very fine addition to the regular furniture business. They are moving ahead and progressing at a rate that any phonograph dealer would be proud to accomplish after two years in business, and are booking an ever-increasing volume.

The Dictaphone, under the supervision of Manager Brown, say that the Atlanta office stood third in the United States last month, being ranked only by New York and Chicago, cities of from fifteen to twenty-five times the population of Atlanta, and it is thought that this is a record of sales to be very proud of.

The trade in general look forward with equanimity to the future, and while there will undoubtedly be some vexations and uncertainty, no one expects the talking machine business to "shut up shop."

AGAIN RESUMES HIS DUTIES

Lester L. Leverich, assistant advertising manager of the Columbia Graphophone Co., New York, who left July 24 for Camp Upton as a member of the draft contingent from his district, has again resumed his duties in the Columbia advertising department. Although Mr. Leverich was keen and anxious to "do his bit" in the fight across the sea, the army surgeons decided that he was not physically able to take his place on the firing line.

PROVIDE MUSIC FOR THEIR FOLKS

Thomas Edens Osborne, the enterprising merchant of Belfast, Ireland, informed The World recently that the unselfishness of the officers and men of the British Expeditionary Force, since the commencement of the war, has been much in evidence. In proof of this he points to the large number of soldiers on leave who have purchased gramophones and records at his store for their home folks' enjoyment.

MOST VALUABLE OF ALL ATTRIBUTES

Initiative is the most valuable of all attributes in helping a man to overflow his present position and thus automatically demand a larger measure of responsibility and remuneration. The world never gets enough of it. The demand to-day is greater than ever.

**COLUMBIA DEALERS
HERE'S A MONEY MAKER**

THE NO. 20



NICKEL PLATED
25 CENTS



Patented Sept. 26 and Oct. 2, 1906
Sept. 10, 1907 and Nov. 27, 1917
Others Pending



GOLD PLATED
50 CENTS

Gives

A CLEAN SWEEP

And
Leaves
A Clean
Track

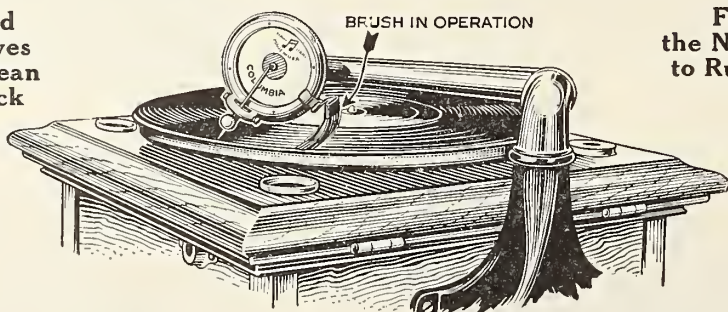

For
the Needle
to Run in

Sample Brush and price list mailed FREE
to authorized Columbia Dealers

Advertising matter supplied with orders

Manufactured by

Blackman
TALKING MACHINE Co.

97 CHAMBERS ST. NEAR CHURCH ST. NEW YORK

Happenings in Dominion of Canada

TORONTO DEALERS ARE BUSY PREPARING FOR FALL TRADE

Columbia Forces Enthusiastic Regarding New Machine Features Introduced—New Victrola Departments Opened—Leading Lines of Machines and Records in Demand

TORONTO, ONT., August 5.—In a letter to Columbia dealers, James P. Bradt, general manager for Canada of the Columbia Co., says: "Our New York executives, our Bridgeport general works manager and his assistants, and our Canadian staff believe that nothing heretofore introduced into a Columbia Grafonola will mean more in the future of Columbia dealers than the introduction of our new motor and non-set stop, which is to be installed in all Grafonola of the floor types and in type 'D.' You have been asking for a non-set stop, or even for a set stop that was satisfactory. We will, in about a month, offer you in this new mechanism an exclusive non-set stop, protected by over 700 claims, exclusively a Columbia Graphophone Co. product, and the only non-set stop on the market, and in all probability the only one that will be on the market, because of the strength of our claims.

"We will also offer you new cabinets of up-to-date design, cabinets that every dealer in furniture, every lover of good furniture in their homes, and every one interested in the furnishing of a home will declare to be instruments of beauty and irreproachable design. As to tone quality, there never has been a phonograph placed on the market equal to the tone quality of these new instruments. The motor is quiet running, more so than any motor we have put on the market. The automatic non-set stop is foolproof."

The Cecilian Co., Ltd., this city, of which John E. Hoare is the head, are now located in their new factory at 89-91 Niagara street. In addition to the manufacture of Cecilian and Farrand pianos and players the Cecilian Concertphone will also be manufactured in this factory for Musical Instruments, Ltd.

When on July 11 Remick's Song Shop, Toronto, opened up a Victrola department, in which "His Master's Voice" products are being featured exclusively, the first customer had the satisfaction of buying a record of his own composition. Morris Manly, who has many worthy works to his credit, dropping into the store for a record, jokingly suggested that it was about time some company recorded something of his. When, in reply to the obliging clerk's question as to the name of something desired, he said: "Up in the Air Over There," the record was promptly forthcoming. To mark the unusual incident an autographed dollar was handed over and is being retained as a souvenir of the opening.

In thirty-eight Ontario towns shortly there is to be conducted a Chautauqua covering a period of a week. Music will play a large part in these gatherings. Willard Osborne, the violinist, will figure in Edison tone tests.

The J. M. Greene Music Co., of Peterboro, supplied an Edison phonograph which was presented to the Protestant Home of that city. Local citizens contributed a fund for the purchase of the instrument, which the elderly inmates are now enjoying.

Among the best-known industries in Canada is that of the George McLagan Furniture Co., Ltd., at Stratford, Ont., the founder of which recently expired in his office. The sudden demise of Mr. McLagan was a severe shock to hosts of warm business and personal friends throughout Canada. His connection with the music industries was comparatively recent, dating from the introduction of the McLagan Co.'s line of lyric phonographs last year, nevertheless, the McLagan industries were known throughout the trade from coast to coast.

The Phonola Co., of Canada, Ltd., which firm take over the phonograph business of the Pollock Mfg. Co., Ltd., of Kitchener, Ont., announce

this month the first list of Phonola records. The Phonola firm, in addition to the parent factory at Kitchener, recently finally completed a transaction whereby they become owners of a factory at Elmira, especially equipped for the production of cabinets. This new addition will take care of the greatly increased demand for the Phonola.

I. Montagnes & Co., distributors of the Sonora phonograph in Canada, have recently received a supply of the "Troubadour" and "Imperial" models, made in Canada. The members of the firm are very much pleased with the work, finish and tone of these Canadian-made goods. The manufacturing of the Sonora will be further developed, making an important addition to the country's industries.

When the members of the Ursuline Convent at Windsor wished to give the Mother Superior a gift on the occasion of her jubilee, they decided on a Model Superb of the Cecilian Concertphone, which was supplied by the Maloney-Connolly Co., of Windsor.

W. B. Puckett, John E. White and F. A. Trest-rail, of the Musical Merchandise Sales Co., Toronto, distributors of the Brunswick phonograph and records, paid a visit to Chicago recently and inspected while there a number of new features

being incorporated in the Brunswick. The company are carrying on an energetic campaign in the West, and Mr. Ross, who has returned to Edmonton from Vancouver and Victoria, reports gratifying orders throughout British Columbia. Mr. Stenberg, in charge of the company's Western office, is arranging for Mr. Ross to assist in exhibiting at all the Western fairs. Brunswick advertising is appearing in the local papers during the period of the fairs and also in the farm magazines. Brunswick retail showrooms have opened in Winnipeg at 323 Portage avenue East, under the name of The Phonograph Shop, Ltd. Mr. Joy, who is in charge of the store, reports sales satisfactory for summer months.

Among recent Brunswick agencies the Musical Merchandise Sales Co. report the Ajello Piano Co., of Vancouver, a well-known music house of that city. The company also report that Johnston & Boone, with a number of branches throughout the West, have taken on the Brunswick line for their chain of stores, which will be known and advertised as the Brunswick stores.

A Brunswick Phonograph was given by War Veterans as first prize at their Dominion Day celebration in Preston, July 1.

A. E. Landon, of New York, has joined the Columbia organization in Canada, and will be the company's representative on the road. W. T. Moore, manager of the Columbia Co.'s cabinet department at Bridgeport, Conn., paid the Canadian division a visit recently.

RECENT CHANGES OF IMPORTANCE IN MONTREAL TRADE

J. J. Flynn Purchases Business of A. K. Kempton and Lays Plans for Expansion—Business Is Good With no Indication of Dropping Off—General News of Interest

MONTREAL, CAN., August 6.—J. J. Flynn has purchased the retail business of Arthur K. Kempton, who in future will confine his efforts to the wholesaling of phonographs and supplies. Mr. Flynn has opened up a fine store at 8 McGill College avenue, where he carries a full line of Gloria phonographs, and in addition maintains a library for the exchange of phonograph records, handles parts and accessories, and also does repairing.

Trade continues good and there is no indication of a change, said Manager Depocas, of the Canadian Graphophone Co., wholesale Columbia distributors for the Province of Quebec. A noticeable feature is the increasing demand and inquiries from dealers for the better class of machines and records. From present appearances it looks as though fall trade will be even better than good.

The volume of business maturing the past month in Sonora machines and Victor records is eminently satisfactory to Goodwins, Ltd.

Thos. Wright, of the Nordheimer Piano & Music Co., Toronto, in charge of the Aeolian-Vocalion end of the business, recently paid his respects to the trade in Montreal and was well satisfied that his line is being given able representation.

An influx of nice business has been noticeable of late with H. P. Labelle, Ltd., Pathé distribu-

tors. Numerous cash sales covering various models helping to swell the month's receipts.

J. W. Shaw & Co.'s phonograph trade of late is by no means diminishing, an increasing business being observable. Generous examples of the popularity of the Columbia line of Grafonolas and records being evidence the past month, said Manager Rampsberger.

The Berliner Phonograph Co. report Brunswick and Columbia sales as most gratifying for summer selling.

The annual picnic of the employes and branch offices of the Berliner Gramophone Co., Ltd., occurred on August 3, the destination being Lavaltrie by boat. Detail Sales Manager S. H. Brown, the president of the various organizing committees, had matters in shape, and this was a sufficient guarantee of the day's success.

A large number of Sousa's records, especially the new band ones, were sold by the Berliner stores during the visit of this exclusive Victor artist to Montreal. A new autographed photograph of himself was given personally by the band king to Mr. Berliner, and during his appearance here occupied a prominent position in this firm's show window, in conjunction with a notable showing featuring Sousa's records.

Trade with the Berliner Gramophone Co.'s retail stores is improving as the days go by. The

(Continued on page 54)

Talking Machine Supplies and Repair Parts

SPRINGS, SOUND BOX PARTS, NEEDLES

THE RENÉ MANUFACTURING CO. MONTVALE, NEW JERSEY

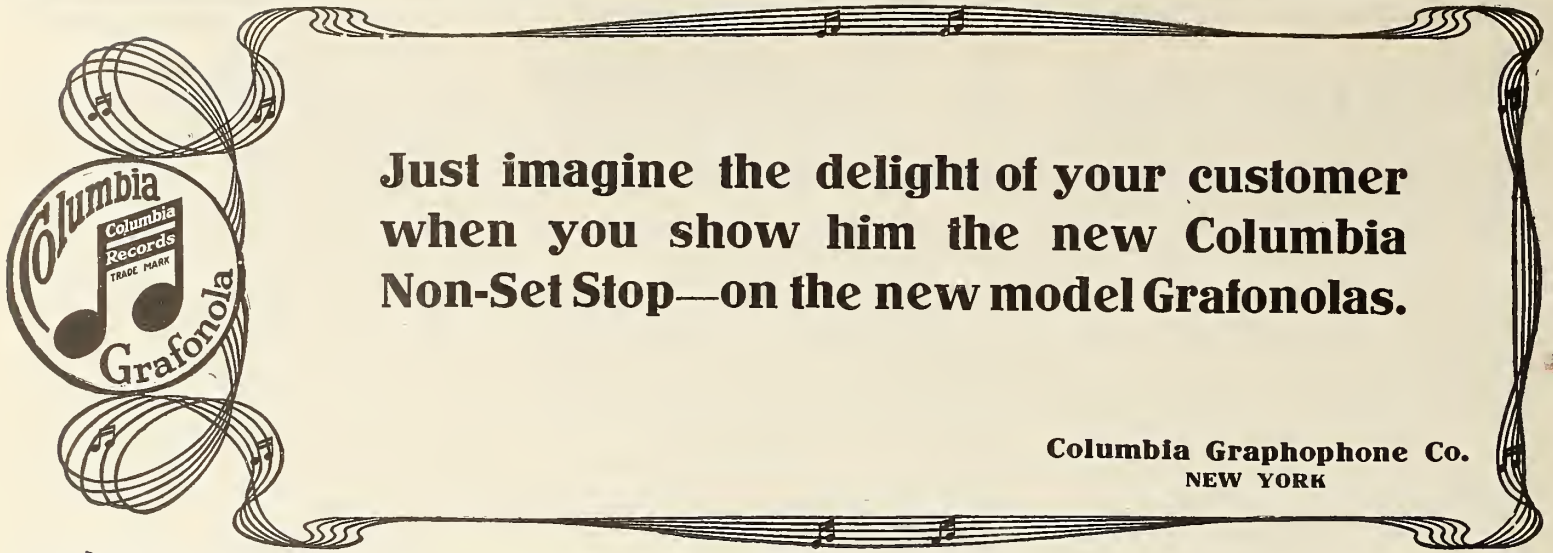

Just imagine the delight of your customer when you show him the new Columbia Non-Set Stop—on the new model Grafonolas.

**Columbia Graphophone Co.
NEW YORK**

TRADE CONDITIONS IN THE DOMINION OF CANADA—(Continued from page 53)

volume of July business being considerably ahead of the same month a year ago in actual number of Victrolas and Victor records disposed of.

The widespread and ever-increasing demand for the Columbia line in this city is in part due to the prestige these goods have been given locally by Almy's, Ltd. Miss Vezina reports trade good and predicts still better business for later on in the season.

Wm. Lee, Ltd., are doing a steady business with the new Edison Diamond Machine, and of late have sold a considerable number of Edison Amberola Cabinet models. This also applies to Columbia Grafonolas.

The Brunswick Shop report that they are satisfied with July business, and state that the Brunswick machine has undoubtedly made a decided bit with the musical people in this city.

Manager George S. Pequegnat, of the Exclusive Phonograph Shop, Reg., reports that Pathé and Aeolian-Vocalion sales have been good.

Creators' Band will shortly visit Montreal for a two weeks' engagement at Dominion Park, and in anticipation of this Columbia dealers are stocking up largely in preparation for a spirited demand of this band's recordings.

T. A. Hubley has opened up in the phonograph business at 57 Louisburg street, Halifax, N. S.

Goodwins, Ltd., the well-known department merchants of this city, are giving their phonograph department good prominence in their local advertising. In a recent announcement three types of the Sonora phonograph were shown, and of which line they carry a full range. In records they are featuring the Victor exclusively.

George H. Peate, who recently organized the Peate Musical Mfg. Co. in this city, to distribute the "York" record, of which he has secured the exclusive rights in Canada for a term of years, visited Toronto recently.

A. C. Skinner, one of the prominent jewelers of Sherbrooke, Que., has put in a stock of phonographs and records.

H. C. Wilson & Sons, Ltd., Sherbrooke, Que., are enthusiastic Victor dealers, and quite recently ran an interesting reader in the Sherbrooke Record.

The Ideal Phonograph Co., Sherbrooke, Que., have registered as a new firm.

A. Gagnery has joined the sales staff of C. W. Lindsay, Ltd. and is identified with the phonograph department.

"His Master's Voice products have been productive of good results lately, particularly in Victrola, Styles X and XI, which we find are our best sellers," said W. J. Whiteside. "One most satisfactory thing we find in handling the Victor line," said this house, "is the fact that when the machine is sold we are not quaking in our shoes for fear of the customer coming back with complaints with reference to the running of the machine, etc. The only time we find he does return is to buy and select Victor records. Victor records sold well during the visit of Sousa's Band during the past month."

"Summer business in Aeolian-Vocalion and Sonora machines is not too bad," said Chas. Culross, "and with the leads we have in view it looks as if a good fall trade is in sight."

N. G. Valiquette, Ltd., stipulated to your correspondent that it was no use to grumble as they considered they were getting a just share of trade and that Pathéphones and Pathé rec-

ords were becoming more and more easy to dispose of, the result of having given general satisfaction to the already large number of users in Montreal and vicinity.

THE BRUNSWICK IN WINNIPEG

Phonograph Shop, Ltd., Take Over Phonograph Department of Cross, Goulding & Skinner

WINNIPEG, MAN., August 3.—The Phonograph Shop, Ltd., an incorporated concern, have taken over the phonograph department of Cross, Goulding & Skinner, Ltd., at 323 Portage avenue, this city, and are handling the Brunswick phonographs and records. They are exclusively a Brunswick shop, and are now planning very extensive improvements, which will make the Brunswick Shop in Winnipeg one of the finest in Canada. They have inaugurated a heavy advertising campaign, and is under the management of Arthur G. Joy, who has been connected with local business conditions for the past fifteen years.

ENLARGED LIST SCHUBERT RECORDS

Bell Talking Machine Corp. Also Has Special Selling Plan Which Appeals to and Protects the Dealer—Special Care in Manufacture

The Bell Talking Machine Corp., 44 West Thirty-seventh street, New York City, is now putting on the market a very comprehensive list of Schubert records. For nine months this concern has been working diligently to perfect the hill and dale record of the highest quality. Besides having taken great care in the manufacture and perfection of the record, the Bell Corp. has worked out a selling plan which is of great advantage to the dealer. Through this plan the dealer can secure an entire line of Schubert records for considerably less than \$100. Besides this the plan has been formulated in such a way as to protect the dealer should he find that for some unknown reason he could not sell the records.

The Schubert records are all ten-inch double disc records and in matching up the selection for each record great care has been taken so

that they will be of a similar nature. The list as it stands to-day includes nearly seventy records, making practically 140 selections, and among them are the very latest and most up-to-date songs, marches, Hawaiian and quartet selections, as well as violin solos with piano accompaniment, violin, flute and harp, concert and symphony orchestra, regimental band, military band and others. Where part music, quartet music or band music is played, the distinctive feature of these records, it is claimed, they give the listener the power of individualizing the different voices and different instruments with ease. The list is divided into patriotic songs, popular songs, sacred, instrumental, martial music, dance and miscellaneous selections. The records have been manufactured in such a way that a most finished product in appearance has been produced.

PROGRESS OF DETERLING MFG. CO.

The Deterling Mfg. Co., of Tipton, Ind., are now well at home in their fine new factory building which was recently built by the Chamber of Commerce. This company have perfected plans for the production of a full line of cabinet talking machines, with many special constructive features that are destined to win consideration for their product. The officers of the company are: George P. Bowers, president; J. H. Woodruff, secretary and treasurer, and Phil. A. Deterling, general manager. The plant will be running in full within a very short time. The company intend to build their own cabinets, thus insuring individual creations.

The man who has a new or better way of doing a thing is the one to-day most wanted. Initiative is composed of two parts know-how and one part dare-to. It never roosts in cowards or apologists.

"MAGNET" DECALCOMANIE NAMEPLATES

FOR TALKING MACHINE CABINETS ETC.

Pamphlets with fac-simile illustrations and prices mailed on request.

SMITH-SCHIFFLIN CO.
126 Liberty Street New York City

FROM THE DORAN CO.
45 MICHIGAN AVE
DETROIT

FROM THE PHONOGRAPH CO.
1240 HURON ROAD (Entire 1st Floor)
PHONES - PROSPECT 2140 - CENT 1400
CLEVELAND

SOLD BY WALTER D. MOSES & CO.
Oldest Music House in VA and N.C.
123 E. BRAD STREET
RICHMOND, VA.

SOLD BY J. E. STRATFORD
AUGUSTA, GA.

SOLD BY HURTEAU, WILLIAMS & CO.
MONTREAL - OTTAWA

Kunkel Piano Co.
BALTIMORE

Featuring the Musical Possibilities of the Talking Machine

By William Braid White

[Note.—This is the eighteenth in a series of articles on the general subject of the musical possibilities of the talking machine. The aim of the series is to develop these possibilities from all angles, thus opening up fields for sales expansion oftentimes neglected, wholly or in part.—Editor.]

RECORDS OF THE VIOLONCELLO

It is a fact, as curious as it is unfortunate, that the larger stringed instruments played with a bow have been so little appreciated, while the violin has been so thoroughly overdone. The violin, of course, is the soprano, the prima-donna, as it were, of the stringed quartet, and its lovely voice puts into the shade the more modest tones of its brethren. Yet, in point of fact, it is none the less true that there is precious little good violin playing in the world, and a very great deal of very bad fiddling in its place. The viola, the violoncello, and even the double-bass, or bull-fiddle, are all noble instruments; and when well played are perhaps the noblest voices in all music. Some may object that the bull fiddle anyhow should not be called noble; but who that ever heard the majestic ground tones of the fourteen double-basses in the old Philharmonic Society of New York, now also gone forever, would deny sonority, nobility and compelling power to the great fiddle that plays standing up?

The 'Cello

The violoncello, however, or "cello" as we usually call it in these slangy days, is the strong member of the whole fiddle family, and it happens that its noble beauties have been recognized with fair completeness in the compilation of talking machine record catalogs. If you look through the Victor, Columbia, Edison or Pathé catalogs, or through the smaller ones, you will find a large and increased collection of fine music either in the form of violoncello solos, of songs, etc., with 'cello part written into the accompaniment as "obligato," or of quartets, trios or other combinations of instruments in which the 'cello is a member.

The strength and beauty of this instrument have always made it one of my special favorites and I think that all genuine lovers of musical beauty will be inclined to feel just the same way about it. When, in addition, one has the privilege of preserving the records of the greatest 'cello playing by the greatest cellists, the feeling of reverence for this fine instrument is sure to grow, especially if one likewise takes care to make persistent and very frequent use of as many records as one possesses.

'Cellists

The wonderful playing of Holman, the veteran, of Kronold, of that remarkable girl, Beatrice Harrison, and of Pablo Casals, the most wonderful of all, has been adequately recorded and is available to anyone who has a talking machine. Besides, there are dozens of other records of this instrument in the various catalogs. The total collection of 'cello music is quite large, and yet it is safe to say that many of the finest pieces are neglected, mainly through ignorance as to their virtues. In the present article I want to say something about, first, the fascinating story of the violoncello, and second, the beauties and attractiveness of the various pieces that are to be found in the talking machine catalogs.

The Chest of Viols!

The word violoncello simply means little violone. The Violone was the double-bass of the old family of viols from which the modern violin family springs. All these viols, the double-bass viol, the bass-viol, the tenor viol, the alto viol and the treble viol, were favorite instruments from the beginning of the sixteenth until the end of the seventeenth century, when the inventions of the great school of Italian makers of Cremona began to develop and per-

fecting the modern violin, viola, 'cello and bass.

Anyone who lives in or near New York and who has time for looking occasionally at something out of the usual, can entertain himself and at the same time gain a lot of very interesting and useful information by spending some hours looking over the wonderful Crosby-Brown collection of musical instruments at the Metropolitan Museum of Art, which is probably the finest collection of such instruments, with one exception, in the entire world. Here, among other things, such for example as one of the two known extant specimens of the pianos made by Cristofori, the inventor of that instrument, one may find several cases devoted to exhibiting complete sets of "chests" of the old viols. A chest of viols was a complete set from double bass to treble. All these old instruments were made with flat backs, strung with from five to seven strings, and had their fingerboards bound with frets made of gut, just as the fingerboards of guitars and banjos are now. They were in all other respects, however, almost the counterparts of the present violin family.

"Fiddles"

It is an interesting fact, by the way, that the names of all these instruments derive from one source and are almost the same in all modern languages. The basic word is the Latin fides, the diminutive of which is fiducula, the two meaning, respectively, string and little string. The name in time came to be applied to the stringed instrument itself, a sort of small lyre, known during the later Roman Empire. Sturdy Anglo-Saxon tongues made it fiddle, French softened it gradually from fideille to vielle and thence gradually to violon. By a parallel process the Italians developed the word viola, expanded to violone or diminished to violono, Fiddle therefore is a good, respectable old name, quite as good as violin; in fact, better, since it is closer to the original.

Viola da Gamba

Violoncello means a little violone; and that means a little bass fiddle. In the old viol days it was often called the viola da gamba or knee-fiddle, just as the tenor viol, now obsolete, was called a viola da spalla, because it was played resting on the knee with the head over one

shoulder. The alto fiddle, which we now call viola, was called viola da braccio or arm fiddle and the treble viol was known usually as violino, or little viol, which is what we call it now; violin. All the names, it will be observed, are Italian, which indicates where the fiddles were developed—and indeed Italian fiddles are the only good fiddles. Others may be pretty good; but Italian is Italian in these matters.

Makers

The violoncello, then, is the bass fiddle played between the knees. Its present form, like that of the other three, violin, viola and double-bass, was developed by the great Italian makers of the Cremonese school, Stradivari, the two Guarneri, the Amati, Gasparo de Salo, Maggini and others. It is probable that Maggini was the earliest maker who worked out violoncelli of modern dimensions and perfected tone. The other great makers followed suit, and their productions are now, of course, almost priceless. A fine old Italian 'cello is as rare as a fine old Italian violin, and as lovely to the ear.

Tones

The 'cello is about thirty to thirty-two inches long, strung with four strings, of which the lowest is tuned to C in the bass clef, while the other three are tuned at intervals of a Fifth higher. Its long fingerboard and great consequent range bring its high tones almost up to the height of the upper end of the violin, while its lower end takes it down into the region of the double-bass. Its tone in the lower registers is somber and majestic, its middle is tinged with a gentle melancholy, and in the upper regions is plaintively lovely. The 'cello is not an instrument of gayety but of tender gentleness; it does not laugh, and is perhaps almost too easily moved to tears. Only the hand of a consummate artist can produce from it tones free from all semblance of monotony and all tendency to "groan." The artists whose names have been mentioned, and whose records have been made for the great catalogs, are able always to redeem their noble instrument from the charge of monotony and make it a joy for ever.

Music

The violoncello has always been, of course,
(Continued on page 57)

7th Floor

229 Fulton Street

Clifford A. Wolf

MANUFACTURER OF

Diamond and Sapphire
Phonograph Points

New York City

Phone, 1678 Cortlandt

Ten Million Prospects!

Dealers, it is estimated that over ten million talking machines are now in use in this country. Every owner will be interested in the marvelous vibrant tube

The VIVITONE

(Patent Pending)

Here is the most wonderful Tone Controller ever produced: a simple contrivance that adds to the tone value of any instrument, no matter what the price.

You will make and hold an army of new customers by demonstrating its unique qualities and it is so reasonable in price that the demand for it is bound to be universal.

The Vivitone Controller is simply a small vibrant tube inserted into the needle-post of the sound box. It fits ALL phonographs using either ordinary steel or Tungsten needles.

Use the Vivitone and You Will Hear the Artist's Real Voice or Instrument

This will appeal to the critics and the great mass of music lovers alike.

A heavy or loud needle inserted into the vibrant tube reproduces the true value and color of tone of instrument or voice, eliminating at the same time the blasting, harsh, strident effects of steel needles. At the same time it minimizes and corrects many other faults of records and diaphragms.

To grade the tone to desired volume without sacrificing clearness simply turn the set screw in the sound-post; tightly for loud, and slightly relaxed for the softer and mellow tones.

Try the Vivitone yourself and you will become an enthusiastic advocate of this simple way to acquire the sweet and natural tone that is desired above everything else.

The majority of phonographs use the mica diaphragm because of its brilliance, but it does emit occasional strident tones and in the louder passages of the records, blasting notes. The Vivitone corrects these defects without lessening the brilliancy.

On phonographs using diaphragms made of other material, the Vivitone regulates the tone volume to get the very best musical effect without muffling the sound.

Favorite Records Take on New Richness of Tone with the use of the Vivitone

Every lover of music will thank you for demonstrating the wonders of this simple little invention. You will find the Vivitone is a Talking Machine accessory that helps you add to that valuable asset of trade—the GOOD WILL of those to whom you sell it.

Each package contains four tubes which will play thousands of records and retails for 50c. Very liberal discount to dealers.

Sample FREE to Any Dealer

So certain are we that you would be eager to sell the Vivitone if you really knew what wonders it accomplishes, we will send a sample Vivitone free to any rated dealer. Write on your letterhead for Dealers' Proposition and the free sample today.

The Vivitone Controller Company

400, 401, 402 Bell Block

Cincinnati, Ohio

New Model Grafonolas—new styles of design; new type of motor; new and improved tone-quality; many other mechanical improvements.

**Columbia Graphophone Co.
NEW YORK**



THE MUSICAL POSSIBILITIES OF THE TALKING MACHINE

(Continued from page 55)

mainly an instrument for the orchestra or for smaller aggregations of strings, and in consequence the quantity of music specially written for it is relatively not very large, though absolutely it amounts to a goodly bulk. Handel and Bach are the earliest writers who have taken the violoncello as a separate voice and treated it accordingly, as the famous six pieces of Bach, and the employment of the instrument by Handel as obligato player with the voice in his oratorios, well indicate. Beethoven wrote several sonatas for 'cello and piano, and Mozart gave much prominence to it in some of his string quartets. Golterman and Popper may be mentioned as two writers of the nineteenth century who not only composed many original works for 'cello, but arranged much other music for it from compositions originally written for other instruments. Mendelssohn's wonderful Air with variations for 'cello, with piano, remains one of the finest compositions for the instrument. Schumann, Noliue, Goldmark and others have written concertos for 'cello with orchestra and Pablo Casals plays a marvelous set of symphonic variations by Boellman. Tschaiikowsky has written some Rocco variations, and there are many other pieces of the same sort.

For various reasons, however, arrangements of music originally written for other instruments have been adapted to the 'cello. The catalogs of records will be found to contain much matter of this sort.

A First Piece

If I were going to choose one special piece for the purpose of introducing a novice to the music of the 'cello as recorded, I think perhaps I should take the Edison record of Paul Gruppe's playing of Schumann's lovely Traumerei, which, in these days, is better termed "reverie." The piece was written for piano originally but is certainly better as a violin or 'cello solo, best of all the latter. Here is melody, sweet, pure and withal simple, melody that can and must only charm and subdue, melody in which not a rough tone or fantastic chord exists to irritate the musically crude, while the most refined musical taste must always love it. No better preliminary piece than this can be imagined.

Beatrice Harrison

The very remarkable little English girl, Beatrice Harrison, daughter of a British army officer, born in India and first 'cellist to win the Mendelssohn prize in Berlin, has done some good recording for the Victor. I should especially recommend her playing of the Prize Song from Wagner's Mastersingers, as an example

of broad, fine, flowing melody, wonderfully phrased and played with wonderful tone-quality. And she is only a young girl yet! Her playing of the Russian Cesar Cui's "Orientale," an astonishing piece of virtuosity, both for the composer and for the player, is also worth hearing, but should come later.

Victor Herbert, as some people are not aware, was a 'cellist first of all, and he has recorded a scherzo and waltz of his own, played by himself. Both are more than good. Try them.

Hans Kronold has done an arrangement of the lovely E flat nocturne of Chopin, in the Edison edition and the Tollefsen Trio (piano, violin and 'cello) have made a good double record also for the same.

I might mention many others, but space-pressure forbids. It is necessary, however, to speak of the greatest artist now recording 'cello playing for the talking machine.

Casals

Pablo Casals is by all odds the greatest violoncellist of the day and no one will envy the Columbia people their good fortune in laying their

hands on him for their edition of records. It is not necessary to select any special number from the list of his records. Each is a gem in itself. Casals has been called "the greatest artist who ever drew a bow" and the title is well deserved, especially when it is remembered that the phrase was made by that great Victor artist, the master fiddle player, Fritz Kreisler. Casals is a marvel. I have heard every great 'cellist who has appeared in the United States during the last twenty years, Jean Gerardy, Elsa Ruegger, Anton Hekking, Willem Willeke, Beatrice Harrison, Pablo Casals. Casals is boss of all, without a doubt. His Columbia records are wonderful, simply wonderful! You ought to encourage your customers to have all of them.

No Boches!

Just notice, by the way, that of the above mentioned great players, the first is a Belgian, the second a Swiss, the third and fourth Hollanders, the fifth English and the sixth a Spaniard; not a German superman among them! Whatever can be the matter? Somehow I have a horrible suspicion that we shall find out lots more facts like these. Some day we may even begin to believe that musicians need not be made in Deutschland!

EFFECTIVE CARTOON ADVERTISING

Mann Piano Co. Using That Method to Advantage in Featuring Victor Records

The Mann Piano Co., 209 North Liberty street, Baltimore, Md., has been featuring the new Victor records in a distinctly individual and interesting manner through the medium of advertisements in cartoon form in the daily papers. Attention was called to the Victor record 18,474 of "Indianola," sung by Billy Murray, through the medium of a large sized two column ad, the central drawing showing an Indian on the warpath, holding the Kaiser's hair in one hand, and ready to bounce a stone hatchet off his skull with the other. The chorus of the song was also reproduced, and a number of record sales were directly traceable to the ad.

FORMAL OPENING IN TULSA, OKLA.

The Allen-Thede Music Co., Tulsa, Okla., are now located in their handsome new home in that city, and marked the occasion of their removal by holding a formal reception for the entertainment of their friends and patrons. The opening covered several days, and Victrola concerts constituted a leading feature. Prince Lei Lani, of Hawaii, who has made many successful Victor records, appeared in person and interpreted Hawaiian music for the guests.

THE VALUE OF ADVERTISING

Cutting down advertising in slack times is an example of "penny wise and pound foolish." Advertising is like a magician's bag—more comes out of it than was put in.

**INCREASE YOUR SALES
Mr. Edison Dealer, with the
KENT Attachment
and Sound Box**



Patented March 2, 1915

SIMPLE AND ACCURATE

Made by manufacturers who have specialized in Edison attachments for years.

SEND FOR ONE TODAY

Most Edison jobbers handle our products. If yours does not send direct.

F. C. KENT & CO.

Manufacturers of Phonograph Accessories
COR. MULBERRY AND CHESTNUT STS., NEWARK, N. J.

H. J. SMITH—Jewel Manufacturer

MANUFACTURER OF—Phonograph Diamond and Sapphire Reproducing Points—Recording Laboratory Jewels—Jewel Bearings for Electrical Instruments—Rough Diamond—Diamond Powder—Experimental Work.

Telephone 2896 Market

833 BROAD STREET NEWARK, N. J.

NORTHERN OHIO ASSOCIATION PLANNING ANNUAL OUTING

Arrangements Now Being Perfected for Affair—Chas. K. Bennett on Vacation in East—Pershing Record Makes a Hit—Dr. Spaulding Strong Advocate of Talking Machine for Soldiers

CLEVELAND, O., August 5.—Charles K. Bennett, president of the Talking Machine Dealers' Association of Northern Ohio, announced yesterday, before starting for a two weeks' auto trip through the East with his family, that plans are being perfected for the second annual outing and picnic of the association members.

The place has not been selected but will probably be one of the bathing beaches in or around the city. Prizes in Thrift Stamps will be awarded successful contestants in a baseball game, girls' tug of war, fat men's races, and other similar amusements.

Mr. Bennett, who is manager of the Eclipse Musical Co., said that he expected to be in the East for two or three weeks, and during his absence would visit the Victor factory in Camden, N. J.

"Business with us in the record end of the game is about 40 per cent. better than it was this time a year ago," said Mr. Bennett. "We are having difficulty in getting machines, but on the whole the members of our association are inclined to be optimistic, and I might add shipments are coming through better than might be expected under the unusual conditions. I look for better fall trade, and there is but one thing for us all to do, and that is to push ahead and not get discouraged, because our best licks must be effective in winning this war."

C. C. Lyons, assistant secretary of the talking machine dealers' organization, is in the East looking after business.

The new Pershing record, which has been widely advertised, is being royally received in Cleveland. This Columbia record makes an appeal to owners of machines having relatives in the war, particularly "over there." Dealers predict an unprecedented run on the record, which is looked upon as a "voice from France."

Probably the same reason that prompts Cleveland audiences to sometimes rise when the national air of France is played in a theatre prompts these same people to seek the splendid record "Lorraine, My Beautiful Alsace-Lorraine." "If He Can Fight Like He Can Love" is another record offering that is having a big run in this section of the country.

The Collister & Sayle Co., retailers of Victor machines, announce unusual business for the summer. This firm are also distributors for all kinds of athletic goods. Asked how this class of goods and talking machines go in a

combination the sales manager of both ends of the business said "bully." He said music and "a hankering after athletics go together nicely, particularly with the dear young girls who seek to be up to date." This firm's summer window displays of sporting goods and Victor machines and records is unusually attractive.

"The talking machine business is just in its infancy," said a member of the firm of B. Dreher's Sons Co. "We hardly realized when this new outlet for music was opened what the results will be, but now the future is as clear as daylight. The war will develop rather than retard the talking machine industry, for the war is making more music-lovers than all the teachers in the world."

Superintendent E. P. Spaulding, of the Cleveland schools, one of the best champions of good music the city has, has been granted a year's leave of absence to take charge of educational work among the American soldiers in Europe.

BRISTOL & BARBER INCORPORATE

Organize the Bristol & Barber Co., Inc., With Capital of \$100,000—Noted Men Interested

There was incorporated last week under the laws of the State of New York, the Bristol & Barber Co., Inc. This concern is capitalized at \$100,000 and will take over the business of Bristol & Barber and the Pathéphone Sales Co., of New York. The Bristol & Barber Co., Inc., will continue both the piano bench and stool business conducted by Bristol & Barber in the past and the Pathé jobbing business formerly conducted by the Pathéphone Sales Co., New York, the latter company having been dissolved.

The officers of the new concern are E., D. Bristol, president; C. L. Johnston, vice-president and general manager; N. G. Barber, secretary and treasurer. Mr. Johnston was formerly connected with Steger & Sons, the well-known piano house, in an executive capacity, and for many years has been prominent in piano circles. He will be assisted in the Pathéphone jobbing end of the business by R. B. Caldwell, who will continue to co-operate with and visit Pathé dealers in this territory, and J. G. Klein will assist Mr. Johnston in the piano bench and stool business. The company is planning to expand in various directions, and the new arrangement will enable it to give the dealers in this territory efficient service and co-operation,

Before leaving he declared in favor of the expansion of the talking machine industry.

The talking machine is making home spots in far-away battlefields for hundreds of thousands of American boys who gave up all that was dear to them before they sailed overseas to fight for their country," said Dr. Spaulding. "Wherever I go when I get to Europe I hope to see and hear a phonograph and I shall encourage those back home to send the soldiers all the records possible."

Rex Hyre, assistant secretary of the Cleveland Music Trades Association, is already planning some stunts for the annual banquet and meeting, yet months ahead.

A. L. Jackson, a talking machine dealer of St. Louis, Mo., was mixing among local houses the first of the month.

Talking machine advertising in the local papers keeps its head on the level with other lines of business. Local dealers are using much space in addition to what manufacturers or distributors are regularly buying when new records are released. The May Co. is one of the best, but buyers of local space, using the same for piano and phonograph stories.

particularly in the development of Pathéphone and Pathé disc business.

COLUMBIA MANAGERIAL CHANGES

A. W. Roos Now Acting Manager, Succeeding I. W. Reid in St. Louis—J. L. Dubreil Takes Charge in Cleveland Territory

George W. Hopkins, general sales manager of the Columbia Graphophone Co., New York, announced this week the appointment of A. W. Roos as acting manager of the company's St. Louis branch, succeeding Irby W. Reid, who has resigned from the Columbia service.

Mr. Roos was formerly manager of the Cleveland branch of the Columbia Co. and has been identified with Columbia service for a number of years. He has won the esteem and friendship of Columbia dealers in Cleveland territory and he is receiving the hearty congratulations of his co-workers upon his appointment.

J. L. Dubreil, formerly assistant manager at the Cleveland branch, has been appointed manager in place of Mr. Roos. Although he has only been associated with the Columbia Co. for the past year, Mr. Dubreil has already gained an intimate knowledge of Columbia merchandising systems and plans, and his unceasing efforts to co-operate with Columbia dealers in Cleveland territory are justly rewarded in his promotion to the post of manager.

Efficient Record Service

ECLIPSE

THE accompanying illustration shows one of the numerous efficiency systems we have installed in order to make Eclipse Victor second to none in the matter of giving prompt attention to orders.



Loading Truck Right on Stock Floor

ECLIPSE MUSICAL COMPANY
CLEVELAND OHIO

INTRODUCE VICTOR RECORD FAN

An Attractive and Seasonable Novelty for Victor Dealer Just Issued

A very attractive and seasonable advertising novelty for Victor dealers is illustrated. This fan, printed in red and black on heavy cardboard stock, is an exact facsimile of a double face Victor record, and when imprinted with the dealer's name and address makes a very effective advertisement. Displayed in the show window, with



A Reincke-Ellis Novelty

a card reading "Come in and get yours," a tastefully arranged display of these fans brings the people into the store and keeps the demonstrating booths busy. The Victor Record Fan is very reasonably priced in lots of 250 and upwards, and may be secured from the Reincke-Ellis Co., 608 South Dearborn street, Chicago, specialists in Victor dealer advertising literature and novelties.

TAKE ON TALKING MACHINES

Geo. H. Lennox, a well-known druggist, Eighteenth and Shunk streets, Philadelphia, Pa., has taken on a line of talking machines which he is finding a profitable adjunct to his business.

"Globe" TRANSFER NAME PLATES

Can be easily and quickly applied on

TALKING MACHINES, PIANOS, TYPEWRITERS, SEWING MACHINES, FURNITURE, ETC.

You can order any of the designs illustrated, Style 1 to 7, with your copy, as follows:

250—\$16.00
500—\$20.00
1000—\$27.50
2000—\$40.00
3000—\$50.00
5000—\$65.00

Complete transferring outfit Included with every order.

Write for folder "You Need Decalcomanie In Your Business."

Globe Decalcomanie Co.
74 MONTGOMERY ST. JERSEY CITY, N. J.

Style 1: SOLD BY PAYETTE MUSIC HOUSE, ABERDEEN, WASHINGTON

Style 2: FROM Mc. Donald's, CONNELLVILLE, PA.

Style 3: G. E. WALKER & CO., SPORTING GOODS & VIOLIN VICTRIAS, HOLYOKE, MASS.

Style 4: KELLER'S TEMPLE OF MUSIC, (ELEVEN ENTIRE FLOORS), 2457 O'CONNOR ST.

Style 5: SOLD BY Gaston MUSIC CO., HASTINGS, KEARNEY (GRAND ISLAND)

Style 6: GEORGE A. MULLIN Co., CEDAR RAPIDS, IOWA

Style 7: SOLD BY WHITE PIANO CO., FAIRBURY, NEBR.

STYLES 1 TO 7 CUTS ARE HALF SIZE

CLEVER RECORD SELLING PLAN

How One Edison Dealer Managed to Interest Customers in His Order Records and Incidentally Register Some Real Sales

Under the caption of "Do You Sell What You Have?" there appeared in the Edison Diamond Points for the current month a most interesting story of the success of a Philadelphia dealer in adapting a new plan for bringing to the attention of his customers records that have lain uncalled for on his shelves for a considerable period, and which might be classed generally as "stickers." The experience of the dealer is set forth as follows:

To what extent do you permit your personal preferences to interfere with your record sales? Do you ever stop to consider how many records there are piled away on your shelves that you yourself do not like, or are tired of? Is it reasonable to assume that your customers feel as you do about these records? Perhaps they would find just the sort of music they like best among those supposed "dead ones" that you have piled away as unsalable. And they may never even have heard the ones you are so tired of.

H. E. Blake, one of Philadelphia's progressive Edison dealers, gave these possibilities some consideration after he saw the slogan we printed on the cover of the April Diamond Points—"The oldest music in the world is new to the man who has never heard it." Then he dug out his old stock, dusted it off, and made up packages of records to send out to owners in his district. At the same time he advised the owners that as these packages contained some very fine numbers that he thought they had never heard he was giving them an opportunity to listen to them in their own homes, and to return any which they did not care for at his expense within three days. He sent out twenty of these packages a day until he had gone the rounds of his customers, and his old stock was enormously reduced.

He reports that the results were beyond his fondest hopes. Records, that he had lain awake nights wondering how he was to move, disappeared as if by magic, never to return, and he has the cash in the bank to account for their disappearance. His increase in business for the month of May, over that of May, 1917, is 100 per cent., largely due, he says, to the practical application of our slogan.

Moreover, Mr. Blake informs us, since most of the owners to whom he sent the records were local people, they did not take the trouble to rewrap them for parcels post, but brought them back personally to the store, giving him an opportunity to sell others in place of the ones they didn't care for.

If you will devote as much effort to moving old stock as you do to the new records that sell themselves, you will get results, precisely as did Mr. Blake. Fix this slogan in your memory: "The oldest music in the world is new to the man who has never heard it." Apply it to your business, and sell what you have.

"NEWT'S" AGAIN MAKES APPEARANCE

Clever Little Monthly Edited by Frank T. Nutze Contains Some Worth-While Thoughts

The latest edition of "Newts," that bright little monthly edited in his own peculiar, but effective way by Frank T. Nutze, vice-president of Stephenson Inc., well-known talking machine motor manufacturers, consists chiefly of two articles full of clever thoughts. The first is entitled: "The Dead Cell," and explains how a single dead cell in a chain of batteries will make ineffective the whole circuit. It is emphasized, however, that there are no dead cells in the Stephenson organization. A second article is on "Music in War and Peace," and offers some thoughts on music in this particular which should make it well worth while for the average human to procure quickly and read intently this latest issue of "Newts."

The Latest Creation in Music

The
Phono-Grand



small enough and sufficiently low priced to fit the apartment of the man of moderate means. Elegant enough for the most beautiful nook in the music room of the millionaire.

A musical instrument par excellence. The player is adapted for any regular 88-note music roll. By the use of Q. R. S. expression rolls it becomes a high grade reproducing piano—Small in size, ample in tone of perfect quality.

The talking machine embodies new and exceptionally effective acoustic.

The Phono-Grand is a novelty but a practical one—

It opens up a new field for the talking machine man.

Are you going to take advantage of this really remarkable profit making and business building opportunity?

J. P. SEEBURG PIANO CO.
209 So. State St. Chicago, Ill.

IMPORTANT NOTICE

TO THE AMERICAN TRADE

The Sterno Manufacturing Company
19 CITY ROAD LONDON, E. C. ENGLAND

Manufacturers of the world known COMPACTOPHONE—the most complete portable gramophone extant—beg to announce the conclusion of arrangements for the EXCLUSIVE SELLING RIGHTS IN THE UNITED STATES OF THE

High Grade Motors ^{Manufactured} _{By} **Mermod Freres** ^{St. Croix} _{Switzerland}

WONDERFUL MECHANISM

These motors represent the acme of workmanship and quality. Each part is made to the finest gauge limits and assembled to run with the precision of a watch—silent and true. Messrs. Mermod Freres is an old established Swiss manufacturer. Back of their motors are years of hard practical experience. The experimental stage was left behind a decade or more ago. Reliability and quality is therefore assured.

DIFFERENT MODELS

Mermod Freres motors comprise several types—single and double spring worm and pinion-gear drive, the very latest and scientific method of construction.

CONSULT US

Before placing your orders elsewhere consult us as to prices and terms of trading. We are out for quick shipments and prompt delivery direct from the factory to the buyer.

SPECIAL TERMS TO JOBBERS

Within the near future it is proposed to establish
A CENTRAL DISTRIBUTING DEPOT IN NEW YORK
Meanwhile trade enquiries should be directed to

THE STERNO MANUFACTURING CO.
19 CITY ROAD LONDON, E. C. ENGLAND

PITTSBURGH DEALERS CARRYING ON PATRIOTIC WORK

In Addition to Subscribing Liberally to Various War Funds Trade Is Sending Hundreds of Records to Fighting Men—Little Worry Over Tax—Trade Generally Quite Active

PITTSBURGH, PA., August 5.—With the loyalty that has characterized the talking machine dealers of Pittsburgh since the United States entered the war there is no note of complaint or criticism heard in the various shops relative to the proposed tax on phonographs. In fact, the dealers are a unit in stating "if the United States Government needs money to carry on the war to a successful conclusion it has got to have it somehow." The Pittsburgh talking machine fraternity have been in the forefront of every movement of a patriotic nature that has been held in the Steel City since the war started. In the Red Cross drives, the Young Men's Christian Association campaigns, the Knights of Columbus fund raisings, the Young Men's Hebrew Association's collections and the Liberty Bond sales, the talking machine men of Pittsburgh have had an important part.

In addition to this they have also arranged for the sending of hundreds of records to the soldiers overseas and to the men in the various training camps in the United States. To this, it can be added that their show windows have been freely utilized for the display of patriotic scenes, which while coupled with the exhibition of records and talking machines, nevertheless were a potent factor in increasing and sustaining the patriotic spirit of the people.

The attitude of the talking machine men here can be well stated in the words of A. R. Meyer, the manager of the Victrola department of the Joseph Horne Co. and who is also the efficient and genial secretary of the Pittsburgh Talking Machine Dealers' Association. While not speaking in an official capacity and only presenting his own views Mr. Meyer said to The Talking Machine World representative: "There is no doubt that phonographs will be taxed and we will have to do our bit. The men overseas are giving their all, and it is but the least we can do to help pay the war expenses and back them up. But it should be made to apply with equal force to all so-called luxuries and not be of a discriminatory nature and place the talking machine dealers in the position of being made to pay a tax that other trades or businesses, other things being equal, would not have to pay."

Trade conditions in the talking machine industry in Pittsburgh are reported as quite brisk by practically all of the dealers and jobbers. There is a marked scarcity of certain popular records and some of the leading makes of machines are also difficult to secure, although there is a disposition on part of the dealers to look the situation in the face in a cheerful manner and make the best of it.

The Standard Talking Machine Co., with its characteristic enterprise and far-sightedness, has issued a circular letter to their large and increasing list of dealers calling attention to the Victor record situation and assuring them full and hearty co-operation in the matter of furnishing records. Emphasis is placed in the letter on the large number of good records that are in stock and the wisdom of the retail dealer to care for the interests of his patrons by always having on hand an ample supply of records that are easily available.

J. C. Roush, president of the Standard Talking Machine Co. returned from a trip to Lake Chautauqua, N. Y., where Mrs. Roush and their two children have been spending the summer at their cottage. Mr. Roush managed to make week-end trips to the popular resort.

Wallace Russell, manager of service and advertising of the Standard Talking Machine Co., is another devotee of Lake Chautauqua and during the summer has been making week-end trips via auto to the lake, where his family are sojourning during the heated term.

John Fisher, manager of the Victrola department of the C. C. Mellor Co. with Mrs. Fisher and their son are spending several weeks in Northern Canada. T. E. Shortell, manager of

the talking machine department of Hamilton's, spent his vacation at Cambridge Springs, Pa.

A. N. Ansell, manager of the Victrola department of McCreery's returned from Louisville, Ky., his former stamping grounds, where he spent an enjoyable outing. He was accompanied by Mrs. Ansell. Mr. Ansell reports sales of Victor machines and records during July as exceptionally brisk and exceeding the trade handled during July, 1917.

G. S. Hards, manager of the Victrola department of the W. F. Frederick Piano Co., expressed himself as well pleased with the trend of business during the past few weeks and stated that while there was a scarcity of certain records and machines the firm was able to care for all trade offered in a satisfactory manner.

S. H. Nichols, manager of the wholesale department of the Columbia Graphophone Co.'s Pittsburgh offices, which are located in the Pittsburgh Plate Glass Co.'s Building on Duquesne way, was quite optimistic over the Columbia business in the Pittsburgh territory. He stated that the sales for July especially in records had far exceeded his expectations and had more than eclipsed the sales that were made in July a year ago. "We are aiming to give our patrons the best service possible," said Mr. Nichols, "and we feel that it is one of the factors that has made the Columbia machines and records so popular in this section. Our trade is increasing at a marvelous rate and the indications are that the fall business, for which we are now shaping ourselves to care for, will be the best in the history of this office." Mr. Nichols expressed himself as well pleased at the manner in which the Pittsburgh public received the Pershing record. There was a liberal use of newspaper space to notify the public of the Pershing record and the various dealers used their show windows for displays of the records, which were embellished by the very tasty background in which a life-size photograph of General Pershing and a number of American flags occupied a prominent place.

A. A. Buehn, of the Buehn Phonograph Co., Edison distributors, spoke very pleasingly of trade conditions during the past few weeks and stated that the demand for Edison machines and records showed that they were growing in popularity among the music lovers of Pitts-

burgh. The Buehn Phonograph Co. is located at 513 Wood street, right in the heart of the downtown business section. Demonstration rooms are on the first and second floors. In order to care for the local trade demands the company had placed an auto delivery car in operation.

H. J. Brennen, manager of the Pathé interests in the Pittsburgh district, stated that sales were keeping up for the summer period much better than had been anticipated. The new Pathé machine for camp or trench use is proving a very popular summer seller, he said.

The local demonstration center of the Pathé Co. is at the Pathé Shop on Liberty avenue, which is attractively fitted up with booths and a reception hall. The first floor is given over to a fine display of the Pathé styles of talking machines while the second and third floors are given over to the wholesale department. Among the new retail dealers that have taken on the Pathé line are Gately & Fitzgerald, of both Altoona and Johnstown, Pa.; B. W. Brown & Co., Canton, O.; W. S. Carter, Ashland, Ky.; Anderson & Newcomb, Huntington, W. Va.; John Haskin, Barnesboro, Pa., and the Ironton Music Shop, Ironton, O.

The Dauler & Close Furniture Co. have enjoyed a very satisfactory sale of Cheney phonographs. The firm have the demonstration rooms fitted up on the sixth floor of their building, where the various styles of the Cheney machines are shown.

J. A. Endres, sales manager for the Brunswick phonograph for the Pittsburgh and adjoining territory, stated to The Talking Machine World representative that after a six weeks' trip among his trade in western Pennsylvania, Ohio, West Virginia and southern New York he was convinced that the popularity of the Brunswick machine was fully established. "With the Ulltona, the scientific attachment that makes the Brunswick machine able to play satisfactorily all makes of records, our dealers have a lever by which they can attract and hold trade. I am asking our local dealers to buy with an eye to the future, and with this in view so far as this territory is concerned I am very reluctant to take on new customers, as I feel that due to the war conditions our present trade must be cared for."

H. C. Niles, secretary and treasurer of the Starr Phonograph Co., of Pennsylvania, has just returned from a trip to the factory at Richmond, Ind., and also from a brief visit to the New York offices, and reports that the Starr machines and Gennett records are having a very satisfactory sale.



A Dealer is Sometimes Judged by the Machine He Carries—If it's a

SCHUBERT PHONOGRAPH

the possible purchaser immediately recognizes the merchant as a man of keen discernment, and one whose word, like the Schubert Phonograph, is 100% good.

Our Phonograph; Our Name; Our Guarantee, are but three of the important things you have back of you, when selling our Instruments—There is much more. Will you become a dealer today?

SIX MODELS \$60.00 UP

SCHUBERT RECORDS

A \$30 investment starts you with complete, up-to-date list of Popular, Vocal and Instrumental selections; 20 to 30 new selections monthly; 10-Inch Double Disc. Write for details.



The BELL TALKING MACHINE CORPORATION

Offices and Show Rooms:
44 West 37th Street, New York

Factory:
85 Southern Boulevard, Bronx, New York

Export Department, 498-504 Broadway, New York, N. Y., E. U. A.
Smith-Woodward Piano Co., 1018 Capitol Ave., Houston, Tex., Local Distributor



**New Lamps for Old! Progress, always—
that's the keynote of the new model
Grafonolas with all their wonderful im-
provements.**

Write for
descriptive literature

**Columbia Graphophone Co.
NEW YORK**

DETROIT'S PROSPERITY REFLECTED IN TALKER TRADE

Well-Paid Mechanics Cleaning Out Stocks of Higher-Priced Machines—Sam Lind Resigns From Local Association—Various Concerns Preparing for Fall Demand—General News

DETROIT, MICH., August 10.—Talking machine dealers in Detroit are still inclined to feel that the coming fall is going to be the very best they ever had. They say that even July was a surprisingly good month, and that August will be up to a year ago from the way it has started out. Dealers are finding it quite easy to sell machines priced from \$75 to \$175, the only machines that are going comparatively slow being those below \$75 and those over \$175. They do not even believe that the proposed increased taxation will make any difference. It seems to be almost the unanimous opinion that "if we get the salable merchandise we can sell it regardless of the increased prices." People want talking machines now more than ever so that they can play the splendid assortment of new selections that are constantly being released. People hear the tuneful dance music and the patriotic numbers and they want instruments at home where they can play them as often as they desire. Record and machine business actually is good for August.

There are many reasons why business should be good in Detroit this fall. The town was surely never more prosperous. Orders running into millions are being filled every week and wages are nearly double what they were two years ago for skilled mechanics and those working in any of the factories producing war materials. The latest statistics show that despite war Detroit increased its population nearly 80,000 since the declaration of war and that right to-day there is scarcity of homes. With such a condition prevailing why should not dealers expect to do a good, big business in the fall? As before stated, it is simply a question of whether they will be able to get the merchandise. That's the really big question.

Sam Lind, president of the Detroit Talking Machine Dealers' Association, has resigned from the organization, both as a member and officer. His position as president has been filled by Charles Smith, vice-president, who will continue to act until the annual election about the first of the year.

Wallace Brown, who operates an exclusive Brunswick Shop, reports a very brisk July and August business, far beyond his expectations, and he is an ardent enthusiast over the prospects for fall. He toured to Chicago late in July, taking his family with him.

Max Strasburg has a large stock of goods on hand and is in excellent shape for fall business, although he still has a number of big orders placed that will further assure him of additional stock. Mr. Strasburg's hobby is golf and you can find him almost any afternoon at the golf links of the Detroit Golf Club.

Ed Andrew, of the J. L. Hudson talking machine department, spent ten days of July on a motor and fishing trip through the western part of the state. Ed is a very busy chap these days, being a member of the Michigan State troops which calls for much drilling at night. Several of the Hudson talking machine salesmen who are unmarried are apt to be lost to the firm under the proposed plan of increasing the draft ages. They have been with the firm for a number of years.

The Detroit Piano Co. has vacated the store at 73 Broadway and it is now being occupied by H. N. Ness & Co., who operate The Pathé Shop.

The General Pershing record handled by the Columbia dealers is proving a big winner.

George Cheadle, who operates a retail talking machine store in Springfield, Ill., was

recently in Detroit passing through while on a motor trip to the East. Mr. Cheadle is well known through his long affiliation with the Chicago Talking Machine Co.

Dave Herman, formerly in the record department of the J. L. Hudson talking machine department, has enlisted in the navy.

From the number of people who are daily in the thirty-seven booths of the Grinnell Bros.' store, in this city, the impression one gets is that business there, especially in the record department, is extremely brisk. This concern has not slackened up on its advertising and the minute the new records come out they see that the list gets plenty of newspaper publicity and advertising. They are doing as much advertising as ever during the month of August.

The J. L. Hudson piano store, which handles a complete line of Sonora phonographs, has advanced the \$115 models to \$135 and the \$150 models to \$175. On the other models there has been an advance of \$10. The state distributor for Sonora phonographs is the C. L. Marshall & Co., occupying attractive quarters at 810 Empire Building, this city. The Hudson company, as well as all of the Sonora dealers throughout the state, are doing an excellent business.

The Walker-Rush Co., 2114 West Jefferson avenue, recently engaged in business taking over the phonograph business which had previously been established at that address. Mr. Rush was for a number of years manager of the talking machine department of the Cable Piano Co. store in Detroit. The company is handling a complete line of Columbia goods, and specializing in foreign records. Mr. Rush reports business is very active.

The Edwin H. Jeffery Co., 1906 Gratiot avenue, is among the latest accounts to be opened by the Columbia.

Victor dealers report that they are doing a big business in the small models which people are buying for their summer homes, boats, etc.



MODEL 100

\$35, \$70, \$100, \$150, \$200, \$250

SONA-TONE

A Phonograph of Distinction with the Tone You Can't Forget

SONA-TONE *Quality* means a resonant, full, liquid tone that comes from an especially designed, all-wood sound chamber—and superior workmanship in material, finish and equipment.

SONA-TONE *Reliability* means simplicity of mechanical construction—ease of operation—and convenience and solidity of working parts.

SONA-TONE *Service* means the immediate ability of the purchaser to play all makes of records—without attachment of any sort—and to play a library of from 250 to 1000 assorted records without further expenditure.

We believe that a Sona-Tone eliminates—to a greater extent than any other phonograph—the surface noises of the record.

We believe that it has the same quality of resonance as exists in the Stradivarius violin.

From our sales record—previous to advertising—we believe that a SONA-TONE is a superior phonograph for retail merchandising.

SONA-TONE PHONOGRAPH, Inc.

3421 Broadway, New York City

"The music is on the record—the tone is in the phonograph."

QUESTIONNAIRE ON STEEL SUPPLIES SENT TO TRADE

War Service Committee of Talking Machine Industry Seeks Facts From Manufacturers Regarding Steel Supplies and Requirements for Presentation to the War Industries Board

An important meeting of the War Service Committee of the talking machine industry was held Wednesday, July 17, at the Fifth Avenue Shop of the Columbia Graphophone Co. This meeting was called by H. L. Willson, chairman of the committee, in order to take steps to have the talking machine industry placed on the preferred list in respect to the use of steel and other metals.

Recently a bulletin was issued by the United States Government indicating that new classifications will be allotted manufacturing industries wherein industries will be classified under three headings as far as the allotment of steel and other metals is concerned, these three classifications being known as a "Priority List," with classifications AA, A and B; a "Preferential List," with the classification of C and a D list, embodying all other industries. In the priority list will be included all industries essential to the war, such as munition plants, factories producing tools for munitions, shipbuilding, etc. In the class "C" schedule will be listed those industries that are considered essential to national welfare. The "D" list will comprise all other industries.

The War Service Committee of the talking machine industry at its session on July 17 gave careful consideration to the important subject under discussion, and it was decided to appoint a sub-committee, which would visit the proper authorities in Washington in order to have the talking machine industry placed on the class "C" list as an industry essential to national welfare.

H. L. Willson, chairman of the war service committee, will act as a member of this sub-committee, and will appoint two other members at some later date. According to present plans this sub-committee will make application to the secretary of the United States Chamber of Commerce for recognition as a committee representing the talking machine industry. After this recognition has been granted the committee will then make application to the War Industries Board at Washington, D. C., for a hearing.

Preceding the executive session of the committee M. H. Mathews, of the Thomas Mfg. Co., Dayton, O., accompanied by his attorney, E. E. Burkhardt, gave the committee interesting information concerning the steel situation as he viewed it after a visit to Washington.

The several members of the War Service Committee who attended the meeting were as follows: H. L. Willson, Columbia Graphophone Co. (chairman); E. A. Widmann, Pathé Frères Phonograph Co.; Chas. A. Edison, Thos. A. Edison, Inc.; J. Schechter, Sonora Phonograph Corp.; Arthur L. Cushman, Emerson Phonograph Co.; Louis Rommel, Bell Talking Machine Co., and a representative of the Mandel Mfg. Co.

The committee has since sent out a questionnaire to all concerns engaged in making, manufacturing and selling talking machines, of which the following information was asked:

- QUESTION 1.
- Are you engaged in the manufacture of complete talking machines, including mechanical parts?....
 - If your answer to "(a)" is "No," do you manufacture any of the mechanical parts, and if so, what parts do you manufacture?.....
 - If your answer to "(a)" is "No," state in detail the mechanical parts which you purchase from others, and from whom you purchase the same.....
 - State the amount (in tonnage) of material used by you during the past year, in mechanical parts of talking machines, dividing them as to the following:
 - Tonnage of cast iron.....
 - Tonnage of sheet steel.....
 - Tonnage of screw stock.....
 - State approximately the amount (in tonnage) of such material which you have on hand:
 - Cast iron.....
 - Sheet steel.....
 - Screw stock.....
 - State, as nearly as possible, the exact amount (in tonnage) of the following mechanical parts which you will need for the coming 12 months, in order to continue your production at the present rate, dividing them as to the following:
 - Cast iron.....
 - Sheet steel.....
 - Screw stock.....

- QUESTION 2.
- Are you engaged in the manufacture of mechanical parts of talking machines only?.....
 - If your answer to "(a)" is "Yes," state the mechanical parts which you manufacture.....
 - State the amount (in tonnage) of material used by you during the past year, in mechanical parts of talking machines, dividing them as to the following:
 - Tonnage of cast iron.....
 - Tonnage of sheet steel.....
 - Tonnage of screw stock.....
 - State approximately the amount (in tonnage) of such material which you have on hand:
 - Cast iron.....
 - Sheet steel.....
 - Screw stock.....
 - State, as nearly as possible, the exact amount (in tonnage) of the following mechanical parts which you will need for the coming 12 months, in order to continue your production at the present rate, dividing them as to the following:
 - Cast iron.....
 - Sheet steel.....
 - Screw stock.....
 - Are there any other kinds of iron and steel materials used by you in connection with the talking machine business, which you will require for the coming year, and if so, state the nature, and the amount (in tonnage) thereof?.....

- QUESTION 3.
- What is the value of the iron and steel products which you have on hand, but which cannot be used unless you get other materials to complete the finished product?.....
 - What is the value of the iron and steel materials which you require in order to complete the finished product?.....
 - What would be the total value of the completed talking machines, if you were able to get such additional iron and steel materials to complete the same?.....

- QUESTION 4.
- State the total number of persons employed: In your offices..... In your factories.....
- Subdivide Question 4 as follows:
- The number of females employed: In your offices..... In your factories.....
 - The number of persons under 21 employed: In your offices..... In your factories.....
 - The number of males of draft age employed: In your offices..... In your factories.....
 - The number of males over 31 employed: In your offices..... In your factories.....
- QUESTION 5.
- What are the total annual wages paid in your offices.....? In your factories.....?
- QUESTION 6.
- State the total annual rent paid for offices, factory buildings, warehouses, etc.....
- QUESTION 7.
- How much capital is invested in your business?.....
- QUESTION 8.
- What taxes have you paid during the past year, separating them as follows:
- Excise tax.....
 - Income tax.....
 - Excess profit tax.....
- QUESTION 9.
- Take, for instance, a talking machine retailing at \$100—please state the value of the iron and steel materials which go into the manufacture of such machine?.....
 - Is this a fair percentage of all machines manufactured and sold by you?.....
- QUESTION 10.
- What percentage does your export business bear to your total business?.....
- QUESTION 11.
- Are you under agreement with others obligating you to deliver your product; that is, agreements with assemblers, jobbers, dealers, or the like; and if so, how many such agreements have you, and state the average period thereof.....
- Name
- Address
- City
- State

NOTE:

Question 1 should be answered by all manufacturers or assemblers of talking machines.

Question 2 should be answered by manufacturers of mechanical parts of talking machines only. This includes manufacturers of motors, tone arms, sound boxes, mechanical devices, talking machine needles, and the like.

*This information is necessary in order to avoid duplication of tonnage.

**This information is asked in order to arrive at an understanding, in percentages, as to what is the approximate value of the iron and steel manufactured products used in talking machines, as the same bears to the total value of the completed talking machines.

Please answer each question with all detail at your command, and add any other information which, in your opinion, will aid the committee, so that all the facts relevant to the industry can be most advantageously presented to the War Industries Board in Washington.

After answering this Questionnaire, please sign the same on the lines indicated for that purpose, and immediately send it to the Secretary of the War Service Committee of the Talking Machine Industry, namely—J. Schechter, 10 Wall street, New York City, N. Y.

It is strongly suggested that the concerns in the trade who, for some reason or other have not received their questionnaire to date, either fill out the copy printed herewith, or apply to J. Schechter, at 10 Wall street, New York, for one of the regular copies without delay, as it is important that the committee have all possible information on hand at the earliest date in order to present the proper facts before the authorities at Washington and thereby secure recognition for the requirements of the trade.

Says the Fuel Administrator—**LAY COAL IN NOW**

LAY NEEDLES IN NOW *Is our advice to the dealer*

We still have on hand a fair supply of loud steel needles and can take proper care of those who **Order Early.**

No one positively knows what truth there is in the rumors about needle production. **Don't get caught in the shortage.**



IN PAPER ENVELOPES

MAGIC-TONE NEEDLES

Take advantage of present low prices

55c per thousand in lots of 500,000 and up

In lots of 100,000—60c per thousand
In lots of 10,000—65c per thousand

I. DAVEGA, Jr., Inc., 125 West 125th Street, NEW YORK

Victor Factory Wholesalers

Victrolas—Supplies—Needles

CONCENTRATING ON THE ARTISTS

Service Department of the Columbia Co. Announce a Set of Three Cut-out Figures of Columbia Artists for the Use of Dealers

The Columbia Graphophone Co.'s dealer service department has announced a set of three



Two of the Columbia Cut-Out Figures cut-out figures of popular Columbia artists. These figures are devised for the purpose of concentrating interest upon certain artists and creating a demand for their records. They have been issued at this time in order that the Columbia dealer can call attention to individual artists and individual records during the fall months.



Another Cut-Out other publicity to impress upon music-lovers the distinctive features of the past season's theatrical and concert performances. These three

window-trims will enable the dealer to create this impression as Nora Bayes during the season of 1917-18 was constantly before the public in many stage successes. Pablo Casals; the famous 'cellist, made a tour of America giving concerts in many of the large cities and in quite a number of smaller towns, and Maria Barrientos scored a remarkable triumph last season as a member of the Metropolitan Opera House. All of these well-known artists record exclusively for the Columbia library.

The cut-out figures are artistically designed in seven colors, lithographed on colored paper and mounted on 150-point cardboard stock, equipped with easel and varnished. This material is of a permanent nature, and may be used in connection with almost any window-trim. The designs and art work conform with figures and sketches used in different phases of Columbia national advertising, and form a direct tie-up with this publicity.

WILL TRADE COMMISSION CHANGE?

Manufacturers Who Believe in Price Standardization Watching With Interest Recent Decisions of the Federal Trade Commission

The manufacturer who believes in price standardization as a prime requisite for satisfactory country-wide distribution will find significance in the dismissal by the Federal Trade Commission last month of the complaint against the American Tobacco Co., says Printers' Ink. The complaint, filed April 15, 1918, involved particularly the use by this company of its large sales force to divert retailers' orders from their personally preferred jobbers and wholesalers to jobbers more ready to assist in maintaining the company's fixed retail prices.

The action of the commission in sustaining the company in its denial of the allegations of the original complaint, based on a preliminary investigation, is especially significant because of the hitherto uncompromising position this body has held on the subject of price-fixing; an attitude so strict, in view of the Supreme Court's decisions in the Victor and the Columbia Graphophone cases, that many manufacturers have written to Washington asking whether it were permissible to print the intended retail price on their wrappers and labels.

The charges against the company included agreements with jobbers and wholesalers to maintain prices; alleged refusal to sell to distributors who were not "regular" as to prices; juggling of prices to favor jobbers adhering to its price stand, and to penalize the others; and the accusation that the manufacturer compelled its jobber customers to refuse sales within the

trade, that is, accommodation sales to other wholesalers, unless the latter would maintain the resale price on goods so obtained.

Doubly interesting then was the Commission's acceptance of the American Tobacco Co.'s statement that it refused to sell the concern whose protest started the action because of, in the Commission's own words, "This concern's well known reputation as a price-cutter," as justification for throwing out the complaint.

This would seem to indicate that a clearly-established notoriety as a price-cutter is sufficient reason for a manufacturer's refusal to do business with a jobber or retailer, although members of the Federal Trade Commission have been hesitant in attempting to define the degree of persistency in cutting prices that renders a man an undesirable customer.

Nevertheless, the action of the Trade Commission in the American Tobacco case may be tangible proof that, despite all recent judicial pronouncements, a manufacturer is still free to choose his distributors to eliminate the possibilities of price-cutting.

It will, therefore, be interesting to await this body's decision in other cases that may amplify and particularize as to the principle arrived at in this case, the more so as Commissioner Fort, in charge of resale price cases, has told Printers' Ink that each such case must be considered on its individual merits.

Undoubtedly several such decisions will be necessary to define how far a manufacturer can go in selecting his customers with this end in view, although the Commissioner intimated that the Trade Commission may not look leniently upon the cutting off for price-cutting of a customer otherwise entirely satisfactory.

ONE WHO HAS TRIED AND WON

A successful man is one who has tried, not cried; who has worked, not dodged; who has shouldered responsibility, not evaded it; who has gotten under the burden, not merely stood off, looking on, giving advice and philosophizing on the situation.

The result of a man's work is not the measure of success. To go down with the ship in storm and tempest is better than to paddle away to Paradise in an Orthodox canoe.

To have worked is to have succeeded—we leave the results to time. Life is too short to gather the Harvest—we can only sow.—Elbert Hubbard.

John W. Kelly, of Salem, N. Y., Edison dealer, reports a very substantial summer trade in both the Edison Amberola and the New Edison phonograph.

AMERICAN

AMERICANS embody all the good qualities and special features of phonographs. No dealer can afford not to familiarize himself with this line composed of seven models from which he can satisfy any and all customers. The AMERICANS stay sold.

No. 22

No. 13

No. 5

No. 8

No. 9

No. 10

No. 11

American Phonograph Co.

39 Fountain Street, N. W.
GRAND RAPIDS MICH.

The Development of a Trade Campaign by Means of the Telephone Worth Consideration

Developing a trade campaign by means of the telephone is not entirely a novelty in the talking machine or music trade field, but it is safe to say that its possibilities have not been considered, nor has the campaign been sufficiently developed to realize fully how telephone salesmanship may be made a most valuable assistant to the talking machine dealer where it is intelligently and properly handled.

Telephone salesmanship requires just as much ability and tact as personal selling. Courtesy must prevail, and the salesman must give his entire attention to his selling talk on the phone, and must have his facts marshaled before him so that he will not have to hesitate. Likewise, he should pause at intervals to let the prospective customer have something to say. Moreover, the results of the telephone conversation should be kept carefully on a card index, so that there will be no duplication of effort.

Douglas Emery pointed out some of these facts in a recent article in *Printers' Ink* in which he related the experiences of a member of the retail music trade in handling the music roll business by phone. His remarks are of unusual interest to the talking machine merchant because the sale of music rolls may be considered as distinctly similar to the sale of records.

"Sometimes telephone salesmanship fits into the business scheme in such a way that it is not only profitable to the house which employs it, but to the customer it bears all the earmarks of highly appreciated service. This is the case with a great piano manufacturing house with a retail branch in New York City," says Mr. Emery. "The house keeps a careful card index

of all purchasers of player-pianos, noting the number of persons in the family, style of instrument and particularly the class of music the customer is fondest of. From time to time, as new music rolls come in, the salesman looks them over and selects some which he believes his customer will probably like. Thus a man who has expressed a preference for Beethoven's 'Moonlight Sonata' is almost sure to enjoy Chopin's 'Nocturne in G Major' or Grieg's 'An den Frühling,' while the purchaser of Liszt's 'Hungarian Rhapsodies' should, in the nature of things, be interested in 'La Papillon' or 'The Scarf Dance.'

"The salesman calls his customer on the phone, mentions the names of the new selections which have come in and asks permission to send them out for a trial. 'We have a wagon calling in your neighborhood, anyhow,' he says. 'Keep the rolls a few days and then if you don't wish them we'll have a man stop and pick them up.' Almost always the customer buys part, if not all, of the rolls left with him, and these sales, put through at the expense of only a few minutes of the salesman's time, run into thousands of dollars. A similar plan, by the way, is used successfully by a retailer who sells phonograph records, except that he follows up the leaving of the records much more quickly."

In another part of his article Mr. Emery says: "In a Chicago campaign on pianos a salesman sat down and called 100 numbers taken entirely at random from the book. Sixty people answered their phones, of whom thirty already owned instruments. Of the other thirty no less than ten expressed so much interest in buying that they could be classified as good, live prospects, well worth a personal call.

Women, by the way, usually do much better in telephone selling than men. This is particularly true when housewives are the prospective customers, the woman apparently feeling that she is less apt to be cheated by one of her own sex than by some scheming male creature. Moreover, a husband sometimes shows keen resentment if his wife is called on the phone by a male salesman, and, conversely, a woman salesman has poor luck in selling something where the wife needs to call the husband into consultation before buying."

The various trade pointers referred to by Mr. Emery can be utilized by talking machine dealers just as effectively as by members of the piano or player trade. As a matter of fact, the sales of talking machine records should find an unusually fine opportunity for expansion through the aid of the telephone, while the suggestion to utilize Uncle Sam as an outside salesman by means of prospects secured over the telephone book is also one well worth consideration and action.

NEEDLE DEMAND IN SOUTH AMERICA

The increasing demand for talking machine needles and the difficulty of getting carbon steel formed the basis of a little article by the business editor of the *New York Times* recently. He also remarked that there was a keen demand for needles in South America, which manufacturers here are unable to take advantage of under prevailing conditions.

The Marshall Music Store, Bayonne, N. J., has moved to new and larger quarters at 431 Broadway, that city.

"Cranks on Tone"

who have tried every needle are now perfectly happy with

The DeLuxe Stylus

Loud or Soft

The best semi-permanent needle on the market.

With reasonable care it plays

100 to 300 Records

Sold and endorsed by many of the big dealers and jobbers.

Does not scratch or hiss.

A perfect tone is produced because of

PERFECT POINTS

You can't afford not to carry the DeLuxe Stylus.

Write now for discounts, free samples and descriptive circulars

The Duo Tone

(Enlarged View)

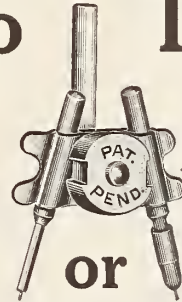

Loud or Soft

without changing needle!

THE DUO-TONE is the final refinement for all machines using a non-permanent needle. A simple, compact device containing one loud and one soft Tungsten needle which can be inserted into the needle holder of any standard machine—the DUO-TONE is a practical talking machine necessity for the following reasons:

With the DUO-TONE, one can play records requiring loud needles as well as those best played with a soft needle without the inconvenience of releasing thumb screw and removing needles after each record.

From 100 to 300 Records Per Needle. Everyone knows the better wearing qualities of the Tungsten. Few, however, know that these needles should be worn down *on one side only* to get best results. The DUO-TONE makes this possible for both loud and soft needles.

Economy—Convenience. Every phonograph user knows the greater economy of the Tungsten needle. The DUO-TONE, therefore, insures this economy *plus the convenience of no needle changes!*

It is already regarded as a practical necessity by those who are now using it. This is a most attractive opportunity for you. Write or wire us at once for our descriptive folder and details on our proposition.

The Duo-Tone Company, Ansonia, Conn.



The New Model Grafonolas are ready. They have many improvements in design and construction that mean money in your pocket. Write for details.

**Columbia Graphophone Co.
NEW YORK**

NEW HOME FOR EISENBRANDT & SONS CO. IN BALTIMORE

Victor Wholesalers Will Move on October 1 to New Building at 417 North Howard Street—
New Quarters for National Piano Co.—General Business Conditions Pleasing

BALTIMORE, Md., August 9.—Talking machine jobbers, and retailers as well, reported good business throughout the month of July, despite the lack of goods to take care of all the orders that could be had. Not alone was the quantity of business in excess of the same month of a year ago, but the cash business done exceeded by far that done in the similar period. Collections are reported as being very good.

Baltimore jobbers are being besieged with orders from all over the country, but none are taking on any new accounts. They are confining their trading to their old customers. All dealers are increasing their monthly orders, and this is probably due to the fact that they have not been able to get their allotments. Their increases, which are also cut, however, make it possible for them to get more goods than they have been receiving heretofore.

Extreme warm weather throughout the month did not in any way affect business. Patriotic records still have the call and war numbers are going very well. Many dealers have arranged patriotic displays of records and big selling of late numbers has resulted. There were many Southern visitors to the Baltimore jobbers during the month, all on the important mission of trying to obtain more goods and to prepare to handle goods for the holiday season.

One of the events of the present month is the announcement by H. R. Eisenbrandt & Sons Co., Victor distributors, of the new warehouse and salesrooms that had been obtained at 417 North Howard street, a block from the present quarters, 308 North Howard street. Henry Eisenbrandt says the new place will be 31 feet wide with a depth of 168 feet running through to Tyson street, which will give a wide thoroughfare for the receiving and shipping of goods. The new place is 9 feet wider and 48 feet deeper than the present quarters. The firm has purchased the new quarters and will not have any landlords, nor be forced to move, as has just happened. The firm reported good business considering the amount of goods received from the factory and could have sold a great deal more if they could have obtained them. The firm expect to be in their new quarters on October 1 unless something unforeseen occurs.

The National Piano Co., Pathé distributors, opened their new salesrooms on Howard street opposite their headquarters. The firm intends to run both places. Jesse Rosenstein, of the firm, reports good business for the month of July and a very liberal shipment of goods. He predicts wonderful business for the Pathé line this fall. July business showed an increase

over a year and record shipments are improving weekly.

With the Columbia Graphophone Co. the business was very good in July, but W. S. Parks, manager, would have liked to see it larger. Failure to obtain goods was the reason why it did not go higher, but the increase was a good one. This was due principally to the arrival on July 30 of five carloads of machines, which were hustled out and reshipped before the close of the month. Mr. Parks was particularly anxious to show a fine increase because July is the anniversary month of George W. Hopkins, the general sales manager of the Columbia Co. Mr. Pennington, the assistant sales manager, was in Baltimore during the month and met the salesmen and made an address. Harry B. Goodwin, of the education department of Columbia, came to Baltimore during the month and visited various educational centers and succeeded in placing a model with the Playground Association. The June visit of T. O. Posky, of the international record department, to Baltimore had a very good effect, for that department in records showed a wonderful spurt.

A. B. Creel, who looks after the Richmond and Norfolk territory, happened to come in at the close of the month and aided in the reshipping of the goods and managed to see that his trade was well taken care of. He finds business exceptionally good in his territory. W. T. Sibbett, who looks after western Maryland and the western part of Virginia, was at headquarters during the latter part of the month. He reports the outlook good, and it is only a question of getting the goods to do the business.

Harry C. Grove has purchased the Washington store of the Columbia Co. and will handle the retail business in that territory, the Columbia not maintaining a retail store there any longer. He is well satisfied with the outlook for business in the nation's capital.

Among the visitors to the Columbia headquarters during the month were: J. H. Resh, of M. M. Crockin Co., Portsmouth, Va.; W. I. Kaufman, House & Kaufman, Washington, D. C.; H. A. Garren, Washington, D. C., and Mr. Kitt, of the A. Jordan Piano Co., Washington, D. C.; Mr. Carey, Columbia Co., Inc., Norfolk, Va.; Mr. Poole, Gaithersburg, Md.; L. E. Oakley, manager of Meyers & Co., Greensboro, N. C.; Mr. Friedberg, Virginia Mercantile Corp., Norfolk; H. L. Stonesifer, Westminster, Md.; Frank LeSueur, Lightfoot-LeSueur Co., Norfolk; H. C. Bright, of H. C. Bright Co., Elizabeth City, N. C.; H. S. Legum, of J. W. Legum, Berkley, Va., and R. P. Roller, Luray, Va.

Amberg & Jorda, Columbia dealers, announce the appointment of Mrs. R. P. Casey as manager of their Grafonola department.

Miss E. M. Griffith, manager of the wholesale department of Cohen & Hughes, reports an increase in Victor business for July, although the shipment of goods from the factory was less in July than it was in the same month of 1917. This was made possible by the sale of records during the month that had not been salable in previous months. I. Son Cohen, of the firm,

Save Yourself Time and Trouble

Let Brown Do It Right



I put the "know how" into it. I know what materials to put into a phonograph case—and what to avoid. Years of experience as a cabinet builder have taught me all the troubles and the ways of overcoming them.

*Cabinets Built from Your Blue Prints
Or My Own Designs Submitted if Desired*

Prices Fitted to Your Selling Proposition. It's the Easy Way for You—and the Safest. Just write to Brown. He does it right.

CHAS. C. BROWN
350 E. Water St., Milwaukee, Wis.

spent a great deal of time at the Victor factory during the month and also looked after the field in general. He is in New York for several days just now in the hope of being able to get more goods.

At the close of the month Mr. Cohen held a sales meeting of the heads of his department and his traveling men. Among those present being Mrs. Walrath, manager of the talking machine department of Kaufman's Big Stores, Pittsburgh, Pa.; A. B. Wertheimer, Victor Taylor and Leslie Lohr; F. S. Harris, manager of the Washington store; J. F. Lens, chief accountant of the firm, and Miss Griffith. After the business meeting was over Mr. and Mrs. Cohen as hosts entertained them at dinner at the Suburban Club and later spent the evening on the roof garden of the New Southern Hotel.

The fine display of the General Pershing and other popular records at the store of William Heinekamp & Son, West Baltimore street, Co-



Artistic Pershing Record Window

lumbia dealer, has brought many sales to the firm. The display has been sent as a model to many firms. Young Heinekamp cut out the figures shown in the offing and hung them with black thread, making the support invisible.

A. P. Petit, manager of the talking machine department of the local branch of the Brunswick-Balke-Collender Co., reports fine business and the arrival of several new models. He has just closed a contract for W. H. Britt to handle his line in Greensboro and Ayden, N. C. He spent about ten days in the South and says business through the section is wonderful, and if he can only get the goods he will surely show some fine business.

W. C. Roberts, for E. F. Droop & Son Co., says that July showed a wonderful increase in business over the July of 1917. Mr. Roberts sent out special lists of records that could be furnished in liberal quantities to dealers and these special lists brought in a great deal of new business. Mr. Roberts left to-day for a trip by motor car with Mrs. Roberts that will include Bar Harbor, Thousand Islands and touring through the mountain section. Among the

visitors to Droop during the month were Messrs. Leroy and Paige, of Ferguson, Lilienfeld & Lightfoot, Norfolk, Va.; Jacob Wheatley, Easton, Md.; E. H. Harding, Norfolk, and D. W. Branch, Petersburg, Va.

W. B. Turlington, manager of Sanders & Stayman, Inc., Vocalion distributors, is highly pleased with the high-grade business being done. While machines are beginning to come in a little better they are not coming any too fast, as Mr. Turlington believes there is going to be a great demand for the instruments this fall, and he wants to get a little stock ahead. Two Art Style instruments were shipped to Connellsville, and there has been a good demand with cash sales for the Vocalions throughout the month.

W. T. Davis, the Victor territory representative, was in town several times during the month.

DEAN BASEBALL TEAM SCORES

PUTNAM, CONN., August 6.—The John M. Dean division of the Otto Heineman Phonograph Supply Co., of this city, has received considerable publicity recently, owing to the success of its baseball nine, which has met many teams in local territory and has not to date lost a single game.

The members of the team recently received from Otto Heineman, president of the Otto Heineman Phonograph Supply Co., Inc., New York, a complete baseball outfit including suits, bats, balls, etc., and R. F. Thomas, superintendent of the plant, at the request of the boys on the nine, wrote Mr. Heineman the following letter of appreciation:

"You will be glad to know that the baseball uniforms and outfit were received last week and given to the baseball team. The boys were very much pleased, and have won every game they have played. The shirts carry the letters 'D D,' meaning Dean Division. Considerable interest in the team has been shown by several well-known baseball players in this section who have expressed a desire to join our factory organization in order to try for the baseball nine. The boys appreciate this kindness which you have extended to them."

DEALERS ORDER WINDOW DISPLAY

I. Davega, Jr., Inc., Victor distributors, 125 West 125th street, report that they are receiving many orders from dealers for the Usoskin window display. This new window display is said to be endorsed by the Victor Company and is expected to be treated upon in the next issue of the "Voice of the Victor."

The Aerotone Music Co., of 121 College place, Portsmouth, Va., has opened a large store with a full line of talking machines.

SOLDIERS APPRECIATE GIFTS

Write Interesting Letters to Otto Heineman Showing How Machines and Records Are Popular in Camp of Aero Squadron

Some time ago Otto Heineman, president of the Otto Heineman Phonograph Supply Co., Inc., New York, presented the 127th Aero Squadron at Langley Field, Hampton, Va., with several Vanophones and a library of Heineman "OkeH" records. These outfits have provided the boys in camp with unlimited entertainment and amusement, and their appreciation of Mr. Heineman's generosity is reflected in the following two letters received by Mr. Heineman this week:

"If you were to enter our barracks at almost any hour during the day or evening you would hear not one but both of our phonographs entertaining groups of soldiers. For a day or two we were so greedy for music that we set both of them going at the same time and in the same place, playing different tunes, but our musical sense gradually got the better of us and we are now content to take them one at a time. The only conscientious objector in our midst is the First Sergeant, who has a little difficulty in getting the flow of music turned off when lights are off for the night. We are most grateful to you for your generous and very appropriate gift."

"Please accept my very hearty, although slightly delayed thanks, for the phonographs and records you sent us. The machines are going all day and most of the night. Music is a great incentive to keep up the spirit of the men, especially men who work as hard as ours do here. We are having great weather and are getting along fine at this field.

"Again thanking you personally as well as for all the men for your most appreciative gift, I remain, yours very truly (Signed)."

HE WAS A REAL VICTOR DOG

Reinald Werrenrath, reports overhearing the following conversation at the Grand Central Station as he was returning from his last concert engagement:

Lady to Gentleman—"Isn't that a lovely bulldog over there?"

Gentleman—"Yes, great."

Lady—"Something like mine. I have a wonderful dog. Yes, I have—and he's nearly a pure breed."

Gentleman—"Nearly?"

Lady—"Yes, he's half bulldog and half fox terrier."

Gentleman—"Well, I have a full-blooded fox terrier. He's the dead ringer for the dog that phonograph company is advertising so extensively."—New York Globe.

THE RESURRECTONE

(Trade Mark Registered)



Read the Trade Mark carefully, hear the machine, and you'll agree that it is truly

The World's Musical Instrument Improves All Records

\$100



Send for samples stating makes of machines. Money refunded if returned within five days from receipt.

Our new Models, fitting Columbia, Victor, Sonora and attachments for Edison (attachment furnished if desired) are LOUDER and CLEARER than any other reproducers. Free of blast and metallic tinge.

Its realistic sound, due to its exclusive "tuning-fork" and "double" piano-wire mounting, is a true "resurrection" of original tones. The "Resurrectone" improves any machine and increases the sale of records. Its Retail Price of \$10 Nickel-plated and \$12.50 Gold-plated (22 karats) is small considering its great merits, and makes it a worth while addition to your source of profits. Regular discounts to the trade.



Height, 44
Width, 20 1/4
Depth, 20 1/4

Other Models \$140, \$190, \$250

Send for catalogue of the complete "Hoffay" line

HOFFAY TALKING MACHINE CO., INC. 3 WEST 29TH ST. NEW YORK CITY

The World's Greatest Artists on Edison Royal Purple Amberol Records at \$1.00

THE new Edison "Royal Purple" Amberol Records made their first appearance on the July list. These super-quality records, the latest product of the "Wizard," priced at \$1.00 (\$1.50 in Canada), are the first of a library of special records of the highest musical quality, and by many of the greatest artists now before the public.

¶ Miss Frieda Hempel, leading coloratura soprano of the Metropolitan Opera Company, has joined the already large and brilliant staff of artists who make records for the



New Edison
Diamond
Amberola
Model 75

NEW EDISON DIAMOND AMBEROLA

and it is a fitting tribute to her glorious voice that it was chosen for the first of the "Royal Purple" Records.

¶ In tone quality, Edison "Royal Purple" Records surpass all talking machine records of similar character—a fact easily proven by direct comparison. And at one dollar they offer records made by artists of international fame. If marketed by any other manufacturer and in any other form records by these artists would cost several times as much.

¶ For highest quality at a low price we do not know of any line of merchandise that compares with the New Edison Diamond Amberola and Edison Amberol Records.

THOMAS A. EDISON, Inc.

AMBEROLA DEPARTMENT

Orange, New Jersey

Are you up on the points of the New Model Grafonolas? They're going BIG! People have never seen such wonderful instruments. Send for descriptive literature.



**Columbia Graphophone Co.
NEW YORK**

COLUMBIA STAFF HOLDS OUTING

Employees of Columbia Wholesale Branch Attend Enjoyable Affair at Bear Mountain as Guests of the Columbia Graphophone Co.

The members of the staff of the local wholesale branch of the Columbia Graphophone Co., 55 Warren street, were the guests of the company at a very enjoyable outing held Saturday July 27. This outing was tendered by the company as a mark of its appreciation of the support and co-operation rendered by the employees of the Warren street branch during the past year. This has achieved remarkable results under the direction of Lambert Friedl, and this outing reflected the spirit of co-operation and good-fellowship that has contributed so materially to this gratifying record.

A party of one hundred assembled Saturday morning at 9 o'clock, and boarded a Hudson River Day Line steamer to Bear Mountain. A very enjoyable luncheon was served at the Bear Mountain Inn, and preparations were made for a baseball game between teams representing the office and shipping department. After an exciting battle the office team was returned the victor on the long end of a 13 to 7 score. K. Mills, assistant manager of the New York branch, was one of the star players on the winning team, and drove in many runs through timely hitting.

After the baseball game was finished a series

of field events was next in order, and the 100-yard dash for ladies was won by Miss Story. The distance throwing event was also won by Miss Story, who incidentally is quite an athlete; Miss Gilfillan finishing second in this event.



Mr. Schreiner Winning Dept. Heads' Race

The 100-yard dash for department heads was won by Wm. A. Schreiner, head of the dealer service department. The 100-yard dash open event was won by Lieutenant Gorham, U. S. N., one of the invited guests of the day; Mr. Schreiner finishing second. The accuracy throw-



Mr. Mills Reaches Plate After Home Run
ing contest was won by Mr. Mills; Mr. Schreiner again taking second place, and winning the point prize.

One of the interesting features of the day was a race between Lambert Friedl and O. P. Grafen, of the sales staff. This race, which was over a distance of two hundred yards, was won by Mr. Friedl, who, after jockeying for rail position in the first one hundred yards, crossed the tape a few inches ahead of Mr. Grafen, whose performance was remarkable in many respects. Lieutenant Gorham won the race around the bases, covering the diamond in eighteen seconds; Mr. Schreiner being the runner-up, finishing only one second behind the winner. Miss Gilfillan won the race around the bases for ladies, covering the distance in twenty-four seconds; Miss Story finishing second, crossing the tape one second behind Miss Gilfillan.

Mountain climbing, dancing and boating contributing to the success of the day, and every member of the party thoroughly enjoyed the program that was prepared, voicing the hope that a 1919 outing would also be scheduled.

For stricter economy in the use of paper the War Industries Board has asked publishers to put into effect a number of economies. Sample or free promotion copies are not to be distributed. Advertisers are to be permitted but one copy and all free exchanges are to be discontinued.

NEBRASKA VICTOR DEALERS TO MEET

State Association Will Hold Annual Convention in Omaha on August 29 and 30

OMAHA, NEB., August 5.—Plans are now being completed for the annual convention of the Nebraska Victor Dealers' Association which will be held in this city on August 29 and 30. P. G. Spitz, who is chairman of the entertainment committee, reports that indications point to a record attendance at the meetings, at which there will be a number of special features, including addresses by Victor factory representatives and by wholesalers as well as business talks by the dealers themselves. An elaborate banquet will head the list of entertainment features planned. It is felt that prevailing conditions, due to the war, make it particularly desirable for the dealers to get together this year for the discussion of their business problems and ways and means for meeting them.

The officers of the association are: Charles Gaston, Gaston Music Co., Hastings, Neb., president; J. E. Gaskill, Gaskill Music Co., Nebraska City, Neb., vice-president; H. S. Thorpe, Huse Publishing Co., Norfolk, Neb., treasurer, and W. E. Mickel, Mickel Bros., Omaha, secretary.

JOINS NAVAL FORCE AT NEWPORT

Leon Tobias, formerly metropolitan representative for Arthur L. Van Veen & Co., New York, manufacturer of Van Veen Bed-Set booths, is now a member of the U. S. Navy, stationed at Newport, R. I. Mr. Tobias is well known in the local trade, and his many friends are sure that he will acquit himself admirably as one of Uncle Sam's Jackies.

Genuine Period Styles

Authentic adaptations of Adam, Louis XVI, Sheraton and Queen Anne periods, harmonizing perfectly with the styles whose names they bear, are a feature of the case work on the Marvelous

MAGNOLA "Built by Tone Specialists"

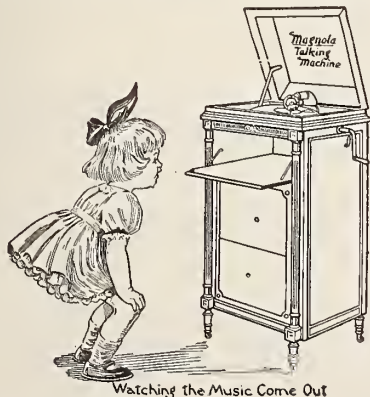

Watching the Music Come Out

Give us the Opportunity to tell you more about this and other sales-making features of MAGNOLA construction, by sending us your name and address.

We have a handsome catalog, illustrated in colors, that tells Magnola's story—and is yours for the asking.

MAGNOLA TALKING MACHINE COMPANY

OTTO SCHULZ, President

General Offices: 711 MILWAUKEE AVENUE, CHICAGO
Southern Wholesale Branch: 1530 CANDLER BLDG., ATLANTA, GA.

The BEST TALKING MACHINE NEEDLE

On the Market—Packed in Counter Salesman



50 Needles to a box and they retail at 10c. per Box.
60 Boxes to a package \$6.00.
This package costs you \$3.90 net.
Your profit is \$2.10 and your customer gets a needle that will give satisfaction.

The Fred. Gretsch Mfg. Co. 60 Broadway, Brooklyn, N.Y.
Manufacturers of Musical Instruments
Canadian Wholesale Agent, H. A. BEMISTER
10 Victoria St., Montreal, Can.

Essentials

—*all of them*

Men

Money

Machinery

Munitions

Merchant Marine

—*and*—

MUSIC

The Government Recognizes Music
As One of the Great Forces That
Will Help Win the War

THE VICTROLA IS THE MOST COMPACT,
INEXPENSIVE, PORTABLE FORM OF MUSIC
OBTAINABLE FOR THE HOME, SHIP OR FIELD

THE TWO
LARGEST EXCLU-
SIVE VICTOR
WHOLESALEERS
IN THE TWO
LARGEST CITIES

New York Talking Machine Co.
119 West 40th Street
NEW YORK

Chicago Talking Machine Co.
12 No. Michigan Avenue
CHICAGO, ILL.

FROM OUR CHICAGO HEADQUARTERS

E. P. VAN HARLINGEN,
Manager

World Office
Republic Bldg., 209 South State St., Chicago
Telephone: Wabash 5774

CHICAGO, ILL., August 10.—Although at first thought the fact may seem somewhat peculiar it is nevertheless being realized as true that our boys in the trenches have a surprising, although indirect, influence on business affairs in this country. We, of course, know that they are consuming millions of pounds of American-grown food and shooting away millions of dollars' worth of powder and shell, the supplying of which is keeping a large part of the population busy. It is known, too, that there is a great demand among the soldiers for musical instruments of all kinds, particularly talking machines, band instruments and small goods generally, but it is not alone along those lines that the influence of the fighting men is felt.

Reports that come to the Chicago office of The World from many sections of the West would indicate that the turning of the tide of the battle on the Western front has its effect on the sales of goods to civilians at home. It is a fact that in certain sections talking machine dealers and others have done more business since the big drive of the Americans along the Marne than they have done in any similar period since the beginning of the war. It is a situation worth thinking about.

Conditions in the trade at the present time are interesting, even though serious. There are many problems that confront the talking machine manufacturer and dealer, not the least of which is the provision of the new War Revenue bill, now in process of drafting, which it is expected will place new tax burdens on the trade in common with other industries. At the present time the Ways and Means Committee of the House of Representatives is said to have agreed upon a 10 per cent. tax on talking machines and records, but as was the case with the existing War Revenue law that figure may be subjected to a downward revision before the new measure becomes effective.

The next problem is that of securing sufficient supplies of steel, fuel and other supplies that will enable the manufacturers to keep their output on a fair basis and keep their manufacturing and sales organizations intact until such time as the dove of peace finds a resting place in the world. The trade is optimistic regarding the attitude of the Government in the matter of allotting metal supplies to the industry,

and feels that the results of the conferences that have been held and will be held in the future with Government officials will work out favorably.

Meanwhile, be it said that the patriotism of the trade as a whole has never wavered, and its members have been willing to take whatever came in a hopeful and earnest and truly American spirit, but it need not be disguised that they were worried. Now the feeling of confidence has been raised to so high a degree that they are not worried. Furthermore, this is true. They realize that this whole thing is only temporary and that after the war they will fall back on the music trade activities, pianos, player-pianos, small goods, band instruments or whatever it may be, therefore, they are not neglecting a future good for the present exigencies, but they have their lines out. The travelers are active. They are keeping it before the trade that they are still in business and that they are preserving the integrity of their name until the boys come home. That is good work and moreover it will happen, mark our word, as it has always happened that the actuality will not be nearly as bad as the anticipations entertained by some people. We are going ahead and we are going to do business. The whole proposition is that socially, politically and commercially we are in an interesting stage of evolution. This in spite of the truth of the ancient assertion, "Woe unto them by whom offenses come for they shall certainly get it in the neck eventually."

A Striking and Timely Advertisement

Timeliness is the keynote of the Nightingale advertisement in this issue. H. B. Wolper, president of the company, has been away on a trip and has come back with some really good orders. This progressive concern is in a sense an instance of the survival of the fittest. Many other concerns have vanished since he started, but he built with indomitable energy his splendid ideals and he is winning out.

Another Empire Success

The Empire Talking Machine Co., of this city, have scored another success in their latest Empire model of portable machines. This new Empire model following so closely to the announcement made in the columns of the July World relative to their Queen Anne period de-

sign instrument further exemplifies the activity of this company and is characteristic of their up-to-the-minute methods of doing business. The new art model Queen Anne design proved to be a very interesting feature to Empire deal-



Empire Portable Talking Machine

ers, and quite a number of requests for immediate shipment for this new model were ordered solely on the strength of the announce-

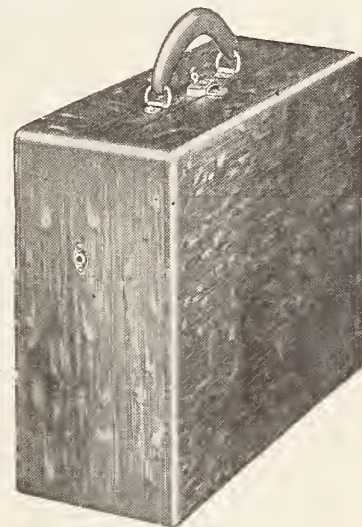

Empire Portable in Case

ment which appeared in the reading columns of The World. The new portable model which is being announced by the Empire Co. this

(Continued on page 73)

THE "WADE" FIBRE NEEDLE CUTTER

assures "20 or more" Original New Points to each Fibre Needle

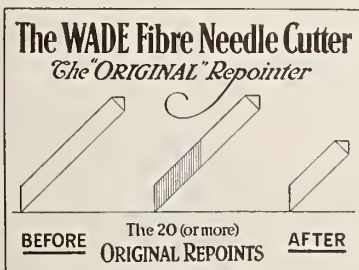

—and therefore is the most economical Fibre Needle Cutter on the market. You know the many advantages of using Fibre Needles—more natural reproduction; more tunes for one cent; no wear and tear on records, etc., etc., but, do not make the mistake of buying anything but the best Fibre Needle Cutter.

The Wade is the oldest Fibre Needle Cutter on the market—
sells on demonstration—
never fails to give satisfaction—
is made in two styles—\$1.50 and \$2.00.

Usual trade discounts—Write for samples
or Order from your regular Distributor



WADE & WADE, 3807 Lake Park Ave., Chicago, Ill.

VICTROLA ART WINDOW DISPLAY SHOW CARDS

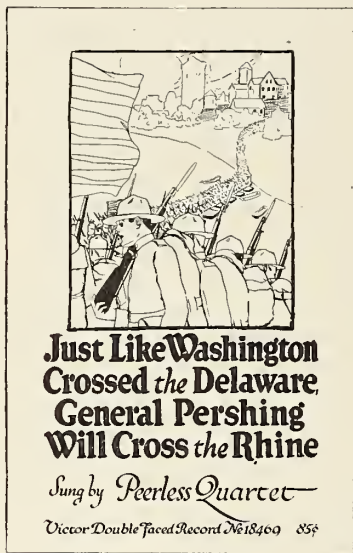
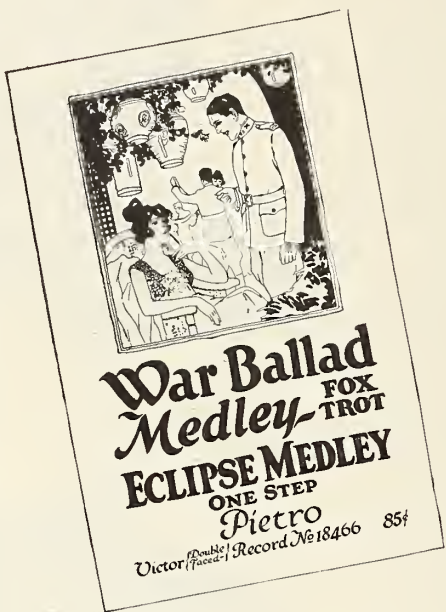

A new Lyon & Healy Service for Victor dealers. These cards are drawn especially for us by a well-known illustrator and are beautifully printed in colors. They are fourteen by twenty-two inches in size. Each month three of the best selling records are selected by our experts and are featured on these cards. They will help you popularize the new records and will add to the appearance of your windows.

\$1.25 per month

Other Advertising Helps for Music Dealers

VICTROLA NEWSPAPER ILLUSTRATIONS, 52 per year, \$8.33 per month; 26 per year, \$4.17 per month. Small instruments newspaper illustrations, 36 per year, \$4.17 per month.

ART VICTROLA FOLDERS for mailing the monthly supplements—save envelopes
Write for Prices

VICTROLA BILL BOARD POSTERS, striking designs
Write for Prices

Lyon & Healy

Victor Distributors
CHICAGO

GOD BE WITH OUR BOYS TONIGHT
Sung by JOHN McCORMACK
Victor Record No. 64775 Price \$1.00

THE LADDIES WHO FOUGHT AND WON
Sung by HARRY LAUDER
Victor Record No. 70117 Price \$1.25

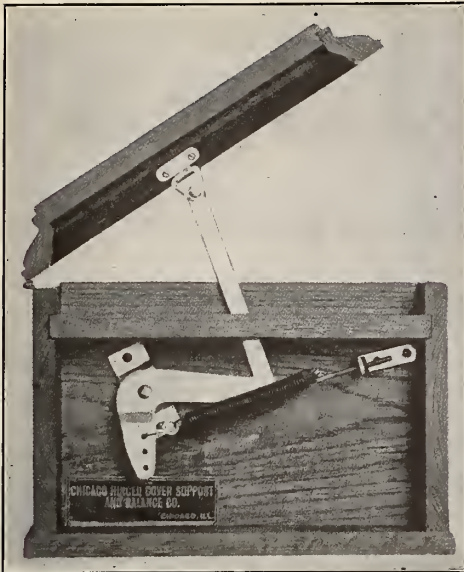

(Pat. Applied For) COVER BALANCE No. 1

ARCHIMEDES (B. C. 287? - 212)

Who discovered the working principles of the fulcrum and lever, astonished his countrymen by saying, "Give me a lever long enough and a place to stand upon, and I will lift the world."

After two thousand years we applied the Archimedes principle to

The Chicago Cover Balance Number 1

And we also astonished our countrymen by saying, "Give us a place to put it on (your talking machine) and we will lift a world of trouble off your shoulders."

We have proved it time and again.

The Chicago Cover Balance No. 1 is scientifically correct in every detail and will give perfect balance to any talking machine cover regardless of weight by means of its simple adjustment.

EQUIPMENT COUNTS

The cover is "PUT" and "STAYS PUT"

WE ALSO MANUFACTURE CONTINUOUS AND EMPIRE TOP HINGES

Chicago Hinged Cover Support and Balance Co. 2242-44 W. 69th Street
CHICAGO, ILLINOIS

FROM OUR CHICAGO HEADQUARTERS—(Continued from page 71)

month is one of the most unique talking machines ever offered to the trade and will appeal at once to a large class of people because of the fact that it is an Empire product, and it is said a new Empire product has never failed to meet with instant approval and bring immediate results. The equipment used in the manufacture of this machine is high class in every way, and the instrument has a tonal volume which particularly adapts it to outdoor or camp uses. It is finished in waxed golden oak and is very attractive. The arrangement for holding a supply of records is original and unique and insures that the records will not be scratched or damaged. One illustration on page 77 shows the new Empire portable talking machine closed ready for carrying and another one shows the working parts, such as turn table, tone arm, crank, etc., placed in their respective positions and compartments. The last illustration shows the instrument set up and ready to play any record. Each machine is packed in a separate carton and for shipping convenience three cartons are packed to the crate, and it is said that the minimum quantity requirements are one crate. It will pay dealers to make inquiry regarding this new Empire model, owing to the timeliness of the season. The retail list price is quoted at \$35, subject to the usual trade discounts.

Complaints

We often hear that there are two sides to everything, but we very seldom read about the second side, especially in a trade paper. We read about the selling and the manufacturing, but that's only one side. The other side is what happens after the machine is manufactured and sold.

Over in Lyon & Healy's retail Victor department they have a nice little room portioned off in one corner of the floor containing a regular sales counter with ordinary customer stools

placed along the counters, well lighted and a little illumined sign over the door which reads "Mechanical Adjustment and Complaint Department." This department is under the supervision of F. L. Clark and Mrs. H. Anderson, and it is up to these two able talking machine people to see the other side of the game and take care of the customers after they have passed from the hands of those who look after the first side.

According to Manager Clark it is one out of ten visits that the sales person is liable to see the customer to whom he sells the machine again. "The customer passes out of his life, so to speak, after the sale, except for an occasional meeting," says Clark. "He must explain his concern and make the delivery, but after that it is all over, so far as he is concerned, but you can't satisfy a customer by selling him a machine no matter how good or what make the machine is and let it go at that. There is always bound to be some adjustment or complaint, no matter how trivial. Then again, you can never satisfy a customer over the telephone. He will call up and make a complaint, and it is up to us to send out a man to make the repairs, if there are any, but if it is just a matter of explaining some detail, it is up to us to try and get the customer to pay us a visit, so we can talk to him in person. It is then a simple matter to straighten out the situation because from the experience in this end of the game one gets so that they can look at their customer and just about tell what the customer is going to talk about, and in that manner prepare themselves for the attack.

"It would take a book larger than The World to cover the story that could be written about this department. Mrs. Anderson says that it takes a man to handle a man's complaint and it takes a woman to handle a woman's complaint, because a man will talk mechanics and perhaps

the woman can talk mechanics better than he, but it won't be so convincing, whereas the other way around the woman can talk household effects and how to polish and clean the machine so it will harmonize with the furniture, but it won't sound so convincing when coming from the man."

Some of the most peculiar excuses were complaints one never heard of and these are gone over in this department daily. For example, one woman came in and talked to Mr. Clark recently complaining that there was a peculiar noise issuing from her machine. Mr. Clark wanted to get an idea what kind of a noise it was, so he could make a suggestion as to whether it was the motor, tone arm or what was making the noise. "What does it sound like," asked Mr. Clark. The woman hesitated for a moment, hemmed and hawed a little and then finally blurted out, "It sounds like snow sliding off the roof."

This was a poser for Mr. Clark, so he decided that one of the repair men should accompany the woman home. The man went over to the motor, inspected it and found no fault therein. The sound box was the same, but still the noise issued from the machine, and then he took the turntable off and found that there was a small ball of paper rolled up and shoved under the table, and it was making the sliding noise which the woman complained about. The repair man showed the woman just what was wrong with the machine and came back and reported what it was, saying at the same time that she remarked, "Oh, dear me," and turned around, grabbed her little boy and gave him a good spanking.

"That is only a sample of the peculiar complaints we have to deal with," stated Mrs. Anderson, "but our really active period is during the Christmas rush and anyone who could come

(Continued on page 75)

TRANSFER NAME-PLATES

We make the Transfer Name-Plates and Trade-Marks for the largest talking machine manufacturers in this country and for dealers in every state.

YOUR NAME, Mr. Dealer, on every machine brings the owner back to you for records and his friends to you for a machine.

Samples, Suggestions and Sketches Furnished Free

THE MEYERCORD COMPANY, CHICAGO

Largest Manufacturers of **DECALCOMANIA** Transfer Name-Plates

The Biggest Idea

of recent years in the phonograph world—
and what it has done for dealers

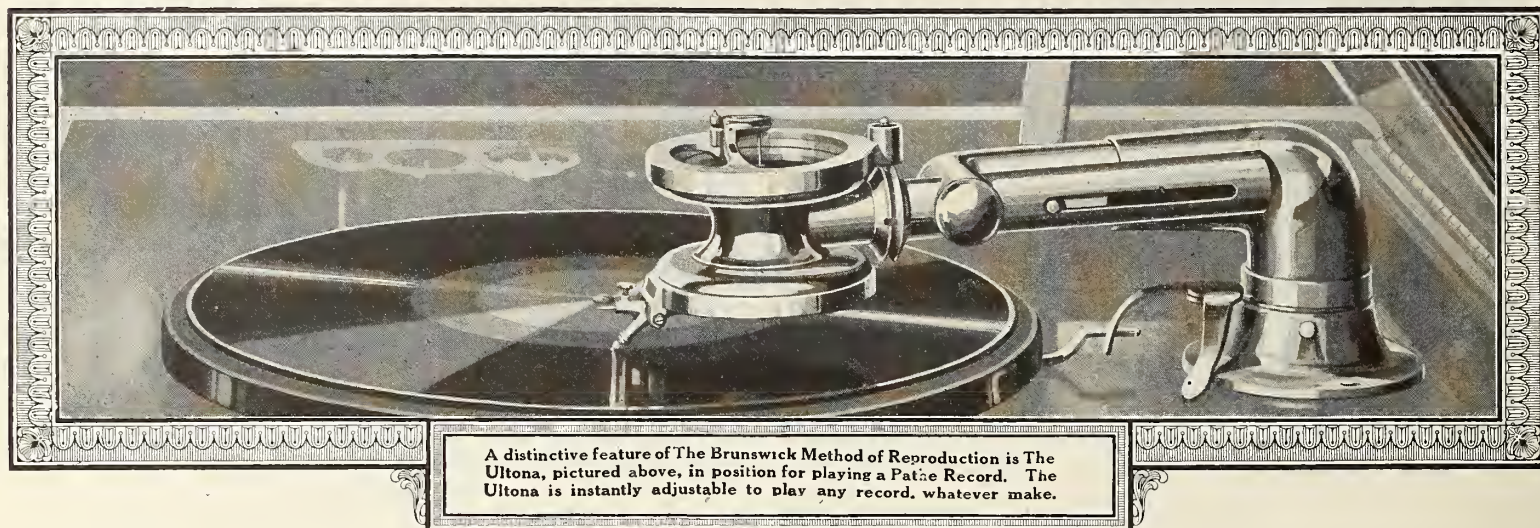

A distinctive feature of The Brunswick Method of Reproduction is The Ultona, pictured above, in position for playing a Pathe Record. The Ultona is instantly adjustable to play any record, whatever make.

The New Brunswick Method of Reproduction Wins Buyers

The most talked about feature in the phonograph field is The Ultona, one of the new ideas embodied in The Brunswick Method of Reproduction. Customers see its advantage instantly. It is an idea most people have wished for, and now that it is obtainable in The Brunswick, old-time favorites are passed by.

The Brunswick Method of Reproduction has been widely advertised in The Saturday Evening Post and other national publications. The copy has been tremendously appealing, chiefly because it created curiosity. It led people in to hear The new Brunswick, and to compare its superiorities. In every ad we urged them to visit a Brunswick shop and hear this marvelous improvement.

The result is that sales have multiplied amazingly. Our production facilities are taxed to the

limit. The Brunswick is a nation-wide success, and its popularity is ever increasing.

Buyers of The Brunswick are demonstrating its superiorities to all their friends. And so a Brunswick dealer is blessed with real "fans" whose influence cannot be underestimated.

Would you like to be associated with this great success? Would you like to become a Brunswick Dealer?

We know of some splendid openings—not many—and maybe your community is on our preferential list.

We suggest writing for the details of our profitable plan, at the same time telling us something of your facilities.

Branch Houses
In Principal Cities of United
States, Mexico and
Canada

The Brunswick-Balke-Collender Company
General Offices: Chicago and New York

Canadian Distributors:
Musical Merchandise Sales Co.
Excelsior Life Building
Toronto



The **Brunswick**
ALL PHONOGRAPHS IN ONE

FROM OUR CHICAGO HEADQUARTERS—(Continued from page 73)

and spend a day with us during that time is sure to go away after having formed an opinion that this department is a veritable mad-house."

"We, of this department," stated Mr. Clark, "always begin the day by saying, 'It is up to us to satisfy and we are going to satisfy our customers at all hazards, as we agree that the customer is always right, no matter how wrong he is.'"

New Additions to Trade

G. Harry Bent, manager of the Victor department of the Geo. P. Bent Co., became the proud father of a baby boy on Sunday, August 4. Don Elble, of Elble Bros., South Bend, Ind., ditto the same day. Both mothers and babies are doing fine. This is Mr. Bent's fourth child and Mr. Elble's first.

Griffith P. Ellis Back at Desk

Griffith P. Ellis, sales manager of the Chicago Talking Machine Co., returned to his desk this week after a two weeks' vacation at Grand Beach, Mich., where he was resting up and recovering from the effects of an automobile accident he suffered several weeks ago. Mr. Ellis and his wife had been motoring at the time of the accident in a friend's car along a dark road during a thunder shower and the machine plunged into a pillar that was being used in the elevation of some railroad tracks. The car was swung around and crashed into a similar structure and Mr. Ellis was thrown through the windshield and his face and head were terribly cut. One of the wounds, a cut on the left temple, necessitated the surgeon's taking ten stitches to close. There were several other cuts about the face which also necessitated some stitching. Mr. Ellis is still undergoing treatment for his wounds, which are not quite healed as yet.

Dan Creed, general manager of the Chicago Talking Machine Co., recently received a letter from Sergeant Geo. F. Denig from somewhere in France. Sergeant Denig is connected with base hospital No. 11, American Expeditionary Forces, and tells of some mighty interesting occurrences that have happened since he has landed in France. Sergeant Denig was formerly assistant credit manager for the Chicago Talking Machine Co.

Columbia Notes

E. C. Poore, formerly in charge of the record department of the Chicago branch of the Columbia Co., has now been placed in charge of both the stock department and stock accounting department, having succeeded Geo. L. Vining, who has resigned. Besides looking after the stock Mr. Poore has supervision over the repair department.

Wm. Link, who for the past three years has been assistant manager of the record department, succeeds Mr. Poore as manager of the record department. The change took place on August 1.

Mr. Poore has long been connected with the Columbia Co., and prior to his connection with the Chicago branch was associated with the Columbia branch at Kansas City. Mr. Link is a

very likable young fellow, ambitious and has the initiative to be just the right man to succeed Mr. Poore.

Frank Tatner, who formerly had charge of the Columbia country correspondence at the Chicago branch, is now doing clerical work for the War Department at Washington.

Undergoes Second Operation

C. L. Davidson, of the Talking Machine Shop, returned to his office August 9 for the first time in four weeks. During his absence Mr. Davidson had undergone an operation for peritoneal adhesions. The complication arose from an operation he underwent last winter for the removal of gall stones and appendicitis. After leaving the hospital last winter Mr. Davidson contracted whooping cough and, owing to the abdominal wounds being fresh at the time he was taken down with the cough, the spasms of coughing caused the raw edges of the wound to adhere to the peritoneum and the gall bladder, which necessitated another operation.

Wiley B. Allen Co. Represent Brunswick

What is perhaps one of the largest deals ever made by the Brunswick-Balke-Collender Co. is that of their new representatives, the Wiley B. Allen Co., of San Francisco. This company, which is one of the largest and best-known retail houses in the country, particularly on the Coast, operates a chain of stores in San Francisco, Oakland, Sacramento, San Jose, Los Angeles, San Diego and Portland, Ore. The transaction was recently brought about with this company to give them the entire Coast representation for the Brunswick phonograph. J. I. Black, of the W. B. Allen Co., who has charge of their various talking machine departments, it is stated, was very favorably impressed with the transaction. This deal puts the Coast representation of Brunswick on such a large basis that it is stated that the Brunswick people are refusing all other representation.

Tells Story of Expansion

F. W. Clement, manager of the Chicago branch of the Emerson Phonograph Co., is one of the members of Chicago's trade who was kept very busy during the recent hot spell in looking after his clientele. Mr. Clement stated that his monthly report showed that business at his office was 25 per cent. greater than during the month of June and that up to the present time indications were that August would be a little ahead of July. He accounts for the increase in July and the first part of August by taking into consideration two factors: first, that the vacationists' demands were taken care of during July, and, second, that the dealers are now going over their stocks and putting in their orders for after-vacation business.

"The dealers," stated Mr. Clement, "are taking the time right now in trying to dope out future business and stock up for the fall trade, and the majority of them are thirty days ahead of their usual time in their ordering. We have been receiving exceptionally heavy shipments from

the factory to this branch lately and are thereby enabled to take care of our demands promptly. In this branch, we are distributing to Indiana, Michigan, Wisconsin, Illinois, Missouri, Kansas, Nebraska, Iowa and Minnesota, and are building a great number of new agencies for our new nine-inch records. The tendency of the demand for both the nine-inch and the smaller Emerson records has been for the patriotic numbers and our books show that about 75 per cent. of the business we are doing is in filling the demand for patriotic numbers such as marches, military dances and war songs. The new nine-inch Emerson records are proving unquestionably that there is a big field for records of this character."

"The Rotometer"

The Lakeside Supply Co. have been spending a great deal of time recently in further protecting their already delicate rotometer or speed tester. This little instrument, which is novel in very many ways and one of the most simple of its kind on the market, has recently been enhanced by the use of a more delicate pivot bar. The Lakeside Co. is also doing some good work in supplying micas of all sizes and thicknesses, of which they have a large supply at present.

Gus Fricke, one of the officers of the company, is invalidated at home, owing to the effects of blood poisoning in his thumb which he received from a razor. The doctor lanced the thumb about six times and for a while he was in a very precarious condition, but thanks to the good work of the attending surgeons his recovery is now assured.

Mr. Geissler Has Sympathy of Trade

A. D. Geissler, president of the Chicago and New York Talking Machine Cos., has the sincere sympathy of the Chicago trade in the death of his sister, Mrs. Nellie Deisinger, who, as reported elsewhere in this issue, was instantly killed in an automobile in which she was riding with her husband. In swinging around the turn at Stony Brook, L. I., the car is believed to have struck an obstruction of some kind and was completely overturned. Mrs. Deisinger was the wife of Albert Deisinger, of Philadelphia, sales manager of the Fiat Automobile Co. She was also a daughter of Louis F. Geissler, general manager of the Victor Talking Machine Co. Many in the Chicago trade who know and admire A. D. Geissler as well as his father feel very deeply over the sad occurrence.

An Interesting "Priority" Letter

The Lakeside Supply Co., 202 South Clark street, this city, have received the following interesting letter under date of August 8 from the War Industries Board, Priorities Division, Washington, D. C., which was signed by Major H. H. Barbour, member. It is of wide interest: "Gentlemen: Replying to your letter of August 5, there is no classification for phonographs and piano hardware. I may say, how-

(Continued on page 76)



Universal Tone Arm



**NO SPRINGS
NOR WEIGHTS
TO ADJUST**

**MADE IN
FOUR
LENGTHS**

Patent Applied For

We have convinced many talking machine manufacturers of the superiority of the Empire Tone Arm and Sound Box and are sure that you can also use this equipment to good advantage on your machine.

There are many features embodied in the Empire Tone Arm and Sound Box that will appeal to you and there is no question but what it will enable you to increase your talking machine sales. Prices and literature sent upon request.

Address all inquiries to Chicago Office :

**PLAYS ALL
MAKES
OF RECORDS
PERFECTLY**

**WRITE
US FOR
PRICES**

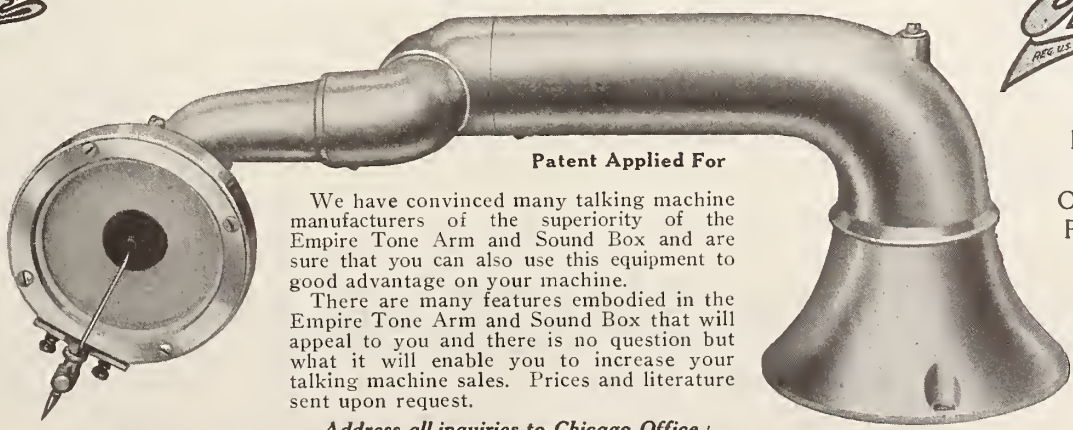

THE EMPIRE PHONO PARTS COMPANY

Sales Office: 425 SO. WABASH AVE., CHICAGO, ILL.
Factory: 1100-1108 W. 9th STREET, CLEVELAND, OHIO

FROM OUR CHICAGO HEADQUARTERS—(Continued from page 75)

ever, that Edwin B. Parker, Priorities Commissioner, is trying to make arrangements with the piano and phonograph people for a hearing in order to discuss the industry, and whatever action is taken at that time will, of course, apply to your business."

Empire Phono Parts Success

The business being conducted at the Empire Phono Parts Co., of Chicago and Cleveland, has recently grown to such proportions that it was found advisable by the heads of this concern to double the capital stock so as to be better able to take care of the rapidly-growing demand for their product, the Empire tone arms and sound boxes. This company has also added to its shipping facilities and is now in a position to make shipments more promptly than heretofore. While in New York J. H. Steinmetz, of the Empire Phono Parts Co., received many compliments on their product from manufacturers he called upon. One gentleman well known to the trade of New York made the

remark that "The man who designed the Empire tone arm and sound box is an artist and the man who is responsible for their manufacture is certainly a mechanic." Mr. Steinmetz stated that the credit for both the design and mechanical achievement went to W. J. McNamara, the president of the company, who is a pioneer in the manufacturing of talking machine equipment and has not only achieved wonderful success in its design and construction, but has also put his great store of knowledge gained through his long experience with the talking machine industry to good use in the marketing of Empire tone arms and sound boxes. Only the highest grade of materials are used in the Empire products and no part is allowed to leave the factory unless it is minutely inspected in every detail. The result is that manufacturers using Empire equipment are having no cause for complaint and are building up a large trade for their talking machines equipped with the Empire product.

Phonographs and Equipment

Phonograph Value is based on the
Standard of Equipment used

Realizing the truth of this statement and what it means to the dealer and his future success,

Hiawatha Phonographs

are equipped with the highest standard of construction, of *Motor, Tone Arm and Reproducer*, which conform with the *beautiful cabinet and artistic lines* of the **Hiawatha**.

Hiawatha Phonographs enable the dealer to put his stamp of approval on each sale and be assured of only the normal percentage of mechanical trouble, which will result in a satisfied customer and increased business.

The **Hiawatha** is made in four attractive models, retail priced at \$50, \$75, \$95, \$125 and \$175.



Style 100

Hiawatha Phonograph Company

209 South State Street
CHICAGO, ILL.

Equip Your Phonographs With Perfect Automatic Brakes

Samples
\$1.00 Each
Cash with order

State make
of tone arm used



Also made
with long
brake shoe
for 1 inch
offset

Patented Aug. 28, '17

Simple construction and easily attached.
Made in four styles to fit any make of tone arm.

Write for attractive quantity price

PERFECT AUTOMATIC BRAKE CO.
Room 400, 425 S. Wabash Ave., Chicago

Brunswick Activities

For the past two weeks A. J. Kendrick, of the Brunswick-Balke-Collender sales force, has been acting as manager of the sales department, owing to Manager H. B. Bibb's absence, Mr. Bibb during this time having been spending his vacation in Michigan, accompanied by his family. Mr. Kendrick stated that both the labor and material situation were in about the same condition as reported by Manager Bibb last month.

"We have been doubling up our territories recently," stated Mr. Kendrick, "and are only taking care of our established agencies at present. In doing this we have increased the responsibilities of our travelers, cautioning them to pay strict attention to our old dealers and solicit no new business.

"Our advertising dealers' service department is well pleased with the success of the new steel road signs, the Brunswick cut-out girl and dealers' folders and pamphlets which were announced through the columns of the World last month and we are in receipt of numerous requests from our dealers for immediate shipment of this advertising material. The dealers were especially pleased with the small envelope size, sixteen-page folders, which we announced last month, and we are taking care of this

"Does It Play All Records?"

Certainly **MAGNOLA** does; and without any extra attachments, too. This is only one feature, albeit a most important one, in the thoroughly up-to-date equipment of the **MARVELOUS MAGNOLA**.

MAGNOLA "Built by Tone Specialists"

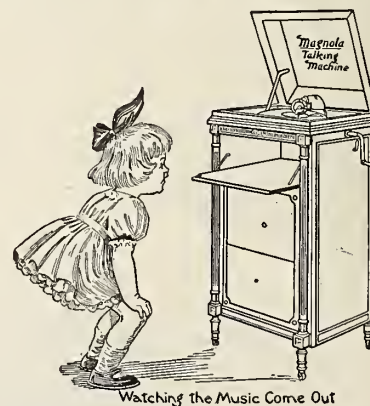

Watching the Music Come Out

May we send you our *handsome illustrated catalog* chock full of information concerning the wonderful construction system of *Magnola* and the beauties of its musical results, its artistic appearance and its moderate price?

Send your name and let us tell you more!

MAGNOLA TALKING MACHINE COMPANY

OTTO SCHULZ, President

General Offices 711 MILWAUKEE AVENUE CHICAGO
Southern Wholesale Branch 1530 CANDLER BLDG. ATLANTA, GA.

FROM OUR CHICAGO HEADQUARTERS—(Continued from page 76)

demand as rapidly as possible. These small folders found instant demand among the dealers in that they are made in a size that will enable the dealer to insert them in an ordinary envelope for mailing purposes. They contain some beautiful halftone engravings, showing every model we manufacture, as well as several views of our new Ultona reproducer and all-wood tone amplifier. On our style No. 110A Brunswick cabinet machine, we are now placing a new model Ultona single diaphragm reproducer. This, like our double diaphragm reproducer, is not a mere attachment, but a distinctly new creation and an essential part of the Brunswick new method of reproduction. By a turn of the hand it adapts itself to any of the vastly different types of records."

The Six Best Sellers

The Columbia Co. announce the six best sellers for the month as follows: "If He Can Fight Like He Can Love" and "Where Do They

Get 'Em and How Do They Get 'Em?"; "Alice, I'm in Wonderland" and "Rock-a-bye Your Baby With a Dixie Melody"; "Belgian Rose" and "My Daddy's Star"; "I Wonder What They're Doing To-night" and "I'm Always Chasing Rainbows"; "Classic Waltz" and "When You and I Were Young, Maggie"; "The Man Who Put the Germ in Germany" and "Mammy's Chocolate Soldier."

Pathé best sellers for the month are: "Your Lips Are No Man's Land But Mine" and "Our Country's in It Now"; "There's a Long, Long Trail" and "Khaki Sammy"; "Military Waltz" and "While the Incense Is Burning"; "Hawaiian Nights Waltzes" and "Somewhere in Hawaii"; "Fancy You Fancying Me" and "The Further It Is From Tipperary"; "My Belgian Rose," and "I Miss That Mississippi Miss That Misses Me."

Victor sellers are announced as follows: "Smiles," fox trot, and "Rose Room," fox trot;

"They Were All Out of Step But Jim" and "We're All Going Calling on the Kaiser"; "Skeleton Jangle," fox trot, and "Tiger Rag," one-step; "American Fantasie," Parts I and II; "My Dough Boy," one-step, and "Calicoco," fox trot; "Canzonetta," Op. 12, No. 2 (Mendelssohn).

Vocalion best sellers for the month are as follows: "Annie Laurie" (sung by May Peterson); "Liberty March"; "Pussy Willow," fox trot, and "Sally Trombone," one step; "Sweet Petootie" and "Liberty Bell"; "The Best Things in Life are Free" and "Darktown Strutter's Ball"; "A Day at West Point" and "American Fantasie."

Emerson best sellers for the month are: "God Be With Our Boys To-night" and "Southern Medleys"; "Three Wonderful Letters From Home" and "A Soldier's Rosary"; "If He Can Fight Like He Can Love" and "If You're Crazy About the Women"; "When Alexander Brings

(Continued on page 78)

THE NEW *Empire* PORTABLE

The big sensation of the phonograph industry

For the boys "over there" and "over here."

For camping parties.

For auto parties.

No summer home should be without one.

**UNIQUE—COMPACT
WELL MADE**



Dealers, get busy! Get our proposition. This wonderful little machine will be a money-maker for you.

Act Now—Today

Packed in Cartons

3 in a crate and shipped in multiples of 3 only

RETAIL PRICE \$35.00

This little machine is fitted with a universal tone arm and will play all makes of records. It is 7 inches high, 15 inches wide and 14 inches deep, and weighs only 17½ pounds. Case is made of solid quarter sawed oak, wax golden finish. Has single spring motor with cast frame. All trimmings in nickel finish. Has wood horn, and the tone volume is loud and clear, especially adapted for out doors. Note the device for holding 12 records.



Write at Once for Literature and Prices

EMPIRE TALKING MACHINE COMPANY

JOHN H. STEINMETZ, President

429 South Wabash Ave., CHICAGO, ILL.

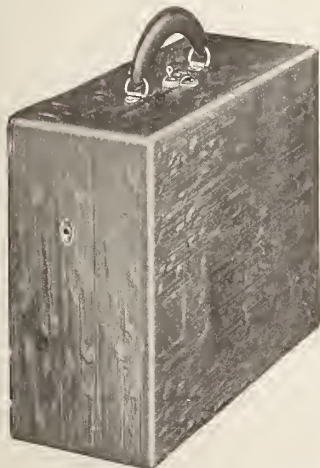

CONTINUOUS HINGES
 ROTOMETERS (SPEED TESTERS)
 MAIN SPRINGS FOR No. 3 AND No. 7
 MOTORS, HANDLES, 12" TURN TABLES
 GOVERNOR SPRINGS AND BALLS
 MICA DIAPHRAGMS, Best Grade, All Sizes
 PHONOGRAPH HARDWARE
 SAPPHIRE POINTS

LAKESIDE SUPPLY CO., Inc.

202 So. Clark Street, CHICAGO, ILL.

Tel. Harrison 3840

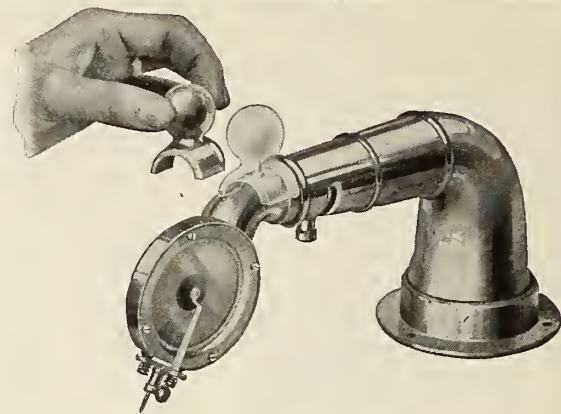

RETAIL PRICE \$7.50 EACH
 Prices to Bona Fide Dealers
 Sample \$4.00 each
 Lots of 6 to 11 3.75 each
 Lots of 12 to 49 3.50 each
 Lots of 50 to 100 3.25 each
 A further slight reduction on yearly contracts
 in 100 minimum lot shipments
 PATENTS APPLIED FOR

FROM OUR CHICAGO HEADQUARTERS (Continued from page 77)

His Ragtime Band to France" and "Cheer Up Father, Cheer Up Mother"; "There's a Lump of Sugar Down in Dixie" and "Everybody's Crazy 'Bout the Dog Gone Blues"; "They Were All Out of Step But Jim"; and "N' Everything."

Pershing Record Stirs Patriotism in Chicago

"Three thousand miles from home an American army is fighting for you. Everything you hold worth while is at stake. Only the hardest blows can win against the enemy we are fighting. Invoking the spirits of our forefathers the army asks your unflinching spirit to the end that the high ideals for which America stands may endure upon the earth."

These are the golden words, straight to the point, which were uttered by Gen. John J. Pershing upon the battlefields of France. These words were engraved upon a gold matrix by the Columbia recording staff at the American headquarters over there. The matrix was brought

to this country, where it was taken into the Columbia pressing plant and records were made for the Nation's Forum. The records were made under the supervision of Guy Golterman and now the original matrix is now safely reposing among the treasures in Washington.

On the reverse side there is a wonderful word picture by Ambassador James W. Gerard. Mr. Gerard's speech is short, sweet, subtle and to the point. He speaks of the problem we faced when America entered the war and of the problem we are facing to-day, saying that before America entered the war it was our privilege to sympathize with any warring nation, but since we are in it there are only two sides, and it is up to the German-Americans to either declare themselves as Americans or traitors.

Mr. Gerard also repeats a part of a conversation between himself and a high German official. The German said, "We have five hun-

dred thousand German reservists in America who will rise in arms if you dare to oppose us." Ambassador Gerard retaliates with the subtle remark that we have in America five hundred thousand and one lamp posts to which the reserves will be hanged the day after they rise. (The extra lamp post was probably suggested for the Kaiser's benefit.) If any German-American were so disloyal to assert himself in favor of the Kaiser he should be given the wooden shoes and the rags he wore when he landed in this country and shipped back to the Fatherland. Further he says that he in the past year has traveled through all the mountainous country of the United States, and over the great plains and prairies and has never seen an animal that would kick, bite or scratch any worse than a big fat German, were he to be hog-tied and shipped back to the Kaiser. This wonderful record is sold to dealers at a price of one dollar, the retail price being a dollar and a quarter, the proceeds of the wholesale price to be turned over to the Red Cross.

We are all in this war to win. Those who are able to fight must fight and those who are not able to fight must seek every conceivable way they can to do their bit. The dealer in pushing this record is not only doing his bit by spreading American propaganda throughout the homes containing talking machines but is also in a position to do a world of good in helping along the wonderful work of the American Red Cross and at the same time making a monetary profit. Dealers, do your bit, and don't let this golden opportunity pass. Help win the war!

Clever Advertising Literature

The Chicago Talking Machine Co. has sent out to its dealers a new set of advertising literature which has aroused considerable comment throughout the trade. The literature is sent out in a large black envelope addressed in white ink and the enclosed folder which holds the letters is also black. Upon the cover page there is printed a picture of a hand held immediately above a flower pot and in the lower corner there is another hand holding a flower pot whereon a young lady is standing. Part of the cover on which the hand at the top is printed is incised in such a manner that it appears to hold a two-cent stamp which is slipped through the slit. The caption on the cover is, "Plant a stamp and raise a customer." The six letters contained within are handsomely colored and contain some very interesting propaganda for the dealer to send direct to his customer. There is a space at the bottom of each letter for the dealer's imprint. At the bottom of each letter there is also an order blank to be filled in by the dealer's customer. This literature is known as the "prospect letter" or blank and the dealer's price for a 100 set is \$6.75 and in 500 sets, \$22.50. Additional 100 sets of over 500 are \$3.75 extra. The New York Talking Machine Co. is also sending out a set of these letters.

A Tonal Wonder

The Morenus Phonograph has won widespread recognition because of its unusual tonal quality. The novel all-wood horn which enters at the bottom (not the top) of the scientifically constructed tone chamber has proven itself astonishingly efficient in securing a most pleasing tone and a remarkably faithful reproduction of the record.

The Equipment is high grade in every respect, plays both types of records, has cover support setting top at any desired angle, original tone moderator, etc.

The Morenus cases are superb productions in every respect.

The MORENUS is in 3 STYLES

- A. OAK, - - 48 inches high. Retail price, \$110
 B. MAHOGANY, 48 " " " " 125
 C. OAK and MAHOGANY, 50 inches high,
 Retail price, - - - - - 150

Very liberal discounts to the trade
 Send for our new descriptive catalog



Style B

The MORENUS PIANO CO.

342 West Huron St.

CHICAGO, ILL.

"Let me gaze, let me gaze on the vision before me."—Faust

Gaze on this beautiful cabinet. Is it not just about what you would expect in the introductory announcement of presentation to the trade of a talking machine by

The
T
E
L
-
O
-
T
O
N
E



The
T
E
L
-
O
-
T
O
N
E

The Western News Company Chicago

BECKWITH TONE CHAMBER

This is absolutely unique, but absolutely safe, and we honestly believe it marks a revolutionary departure in tone production. The phrase we like to use in connection with the Beckwith is "it has tone personality."

There are three things about the Tel-o-Tone which, taken together, make the strongest argument in favor of its overwhelming success.

First, it has remarkable distinctive features, which are not merely talking points, but points of actual merit.

Second, we have succeeded in clothing this instrument in garments of true beauty; in other words the case represents a high standard of architectural design, cabinetmaking, veneers and finished excellence.

The third point is that the company has not, just because they have made an acoustical discovery and a wonderful case, put the price of the instrument at an exorbitant figure. This is the day of service, and, while the public is willing to pay a fair price they must get value. The line embraces six beautiful models ranging in price from \$75 to \$200.

The opportunity is big. But the opportunity may not knock twice at your door asking representation for the Tel-o-Tone in your locality. We would suggest writing or wiring at once. Tel-o-Tone representation will be carefully distributed to dealers of character, financial responsibility and dynamic energy.

THE WESTERN NEWS COMPANY
21 to 29 EAST AUSTIN AVENUE :: :: :: CHICAGO, ILLINOIS

FROM OUR CHICAGO HEADQUARTERS—(Continued from page 78)

Get Thee Behind Me, Trouble

Bathing, swimming and golfing are the only cares at present of L. C. Wiswell, manager of both the wholesale and retail Victor departments of Lyon & Healy, who is spending a two



L. C. Wiswell and His Family

weeks' vacation at South Haven, Mich., accompanied by his wife and family. As the accompanying snapshot shows the trials and tribulations of a talking machine man were left behind, as may be seen by the happy expression of Mr. Wiswell's face. The spirit of the occasion of leaving work and worry behind in Chicago may also be judged from the happy smile in Mrs. Wiswell and her children. The party left Chicago recently in Mr. Wiswell's auto and motored to the Michigan resort, where the enjoyable vacation of two weeks was spent. On the return trip the party motored to several other places in Michigan before reaching Chicago.

Vitanola Activity

There is no doubt but that the Chicago talking machine manufacturers are getting a goodly share of the talking machine business from all

The OROTUND and SUPERIOR

Attachments, Tone Arms and Velvet Running Jewel Points Are Strictly High Grade

There is only one attachment on the market that will do exactly as represented, viz.: play all makes of records safely and with perfect tone on machines which are not made to play all makes of records and that is the Orotund and Superior complete attachment.

When we make the above statement we have said something, because most other attachments are too heavy, or the position on the record is not correct, which means destruction to a record.

You must hear the Orotund and Superior attachment play a few of the high-grade Edison, Columbia, Victor or Pathé records to appreciate that which we are trying to tell you.

Play your favorite record on your machine, regardless of the make, and play it musically, not with all that surface, mechanical, nasal tone.

You have missed a rare musical treat if you have not heard some of the records of all makes which we could name, played with the Orotund and Superior outfits.

Write for prices and descriptive circulars.

COMBINATION ATTACHMENT CO.
20 Jackson Boulevard, East, Chicago, Ill.

parts of the country, as may be seen from recent increases by the Vitanola Co. This company has been running to capacity for the past few months, and in fact their demand has grown to such an extent recently that it was deemed necessary to increase their plant. With this view in mind the heads of the Vitanola Co. set about to look for additional quarters, and at present it is stated they are contemplating the purchase of a large woodworking plant that will enable them to take care of their increased business. This company also states that they will be ready to announce to the trade during either the months of October or November their new line, which embraces several new models of beautiful design. The tendency of their trade has been for the higher-priced machines and they have established many new agencies in all parts of the country. They also report that collections were never better and from present indications there will be no falling down along this line.

Big News Coming

The B. & H. Fibre Needle Mfg. Co. will shortly have an announcement of decided interest to the trade. It will mean the creation of a new system of selling service.

Death of L. V. B. Ridgeway

L. V. B. Ridgeway, general representative of Lyon & Healy's talking machine and small goods department in the West, died at the San Francisco Hospital on Monday of last week. Mr. Ridgeway was taken ill at the annual Bohemian Club's outing in the mountains, and was taken to the hospital, and in a moment of mental derangement jumped from the window. Mr. Ridgeway had been connected with the house ten years and was well known in the trade. He is survived by his brother, P. S. Ridgeway, and a sister, Mrs. Adolph Weidig, of Hinsdale. The body was brought to this city by express, and the funeral services were scheduled to be held on Saturday in Chicago.

Making Stamped Steel Sound Boxes

The Chicago Recording Scale Co., Waukegan, Wis., are reported to have perfected a new talking machine motor along unique lines that will be formally announced to the trade shortly. Meanwhile the company is engaged in stamping sound boxes out of steel in considerable quantities and declare that that method reduces production expense and enables them to deliver the boxes during the present shortage in die casting products.

Attractive Cheney Talking Machine Exhibit

Through its artistic and effective participation in both the January and July exhibits at the Grand Rapids furniture market, Grand Rapids, Mich., the Cheney Talking Machine Co. has become a recognized feature of that famous institution. A complete line of Cheney instruments of both the period design and art models was shown at the July exhibit, the showroom being on the main floor of the Keeler Building. The exhibit was under the personal direction and management of Burton Colver, Cheney sales representative for both the States of Michigan and New York. In common with many of the furniture exhibits the Cheney display had fewer callers at the July exhibit than was the case with the January show, but a remarkable feature that was noticeable by all exhibitors was that in spite of the fact that there were few callers the contracts closed during the month were proportionately larger than during any other exhibit. Among some of the

notable connections made with various dealers by the Cheney Co. during the exhibit were those of B. Altman & Co. and Lord & Taylor, these being New York houses who will represent the Cheney Co. exclusively. M. Welte & Sons and the Ludwig Baumann Co. also placed large contracts for Cheney instruments. Among the Cheney representatives who contributed to the success of the July exhibit were Geo. R. Madson, of the Cheney Phonograph Sales Co., 4400 Euclid avenue, Cleveland, who by the way is operating in Ohio, West Virginia and western Pennsylvania. E. R. Buel, president of Cleveland company; T. Buel and Prof. Forest Cheney, inventor of the instrument bearing his name, were also participants in making the exhibit a success. Other of the Cheney Co. representatives who were also present were A. C. Riine, of the Cheney factory at Grand Rapids, and R. I. Reid, of the headquarters office of the Cheney Phonograph Co., 725 Marshall Field Annex Building, Chicago.

The Cheney service department also received much favorable comment during the exhibit for the work it has been carrying on in the way of monthly bulletins. These bulletins are two-page folder type and are sent to the dealer each month. The first page is printed with the dealer's name and space left for him to print his monthly announcements to his respective clientele. The inside page is taken up with a

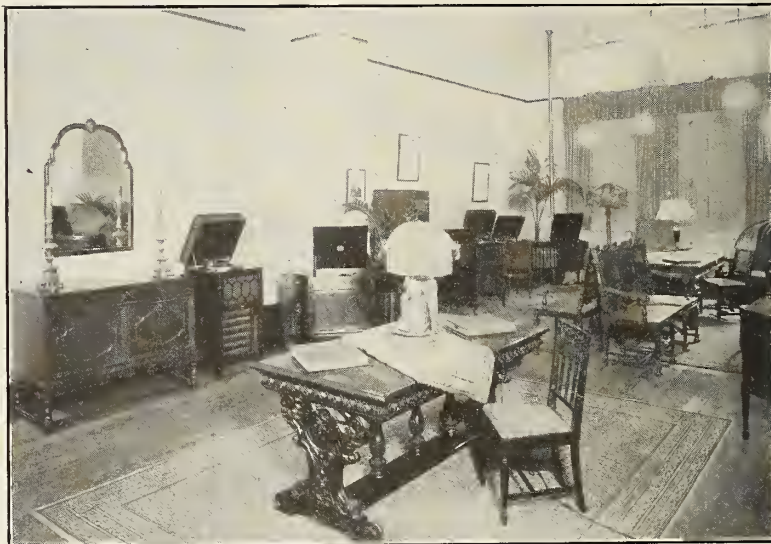

Cheney Exhibit at Grand Rapids Furniture Market

large phantom wash drawing showing the working parts of the tone arm, reproducer and amplifier and the reading matter is given over to a short comprehensive story explaining in detail the working principles of the instrument as shown in the illustration.

One of the reputable agencies established by the Cheney Phonograph Co. lately was that of the Cable Piano Co., of Michigan, which recently opened an account. The Cable Company, it is stated, will soon extend the Cheney line to its various branches throughout the State of Michigan and this account will be given the personal attention of Mr. Colver.

Death of First Lieutenant Jones

Word has been received here of the death on August 3 of First Lieutenant Edwin Llewellyn Jones, former manager of the phonograph department of the Jaeger-McKenzie Piano Co., Oconomowoc, Wis., who went to France in

We Make Stamped Steel

SOUND-BOXES

in View of Shortage in Die-Casting Market

Chicago Recording Scale Co.
WAUKEGAN ILLINOIS

FROM OUR CHICAGO HEADQUARTERS—(Continued from page 80)

February. No details or particulars of his death have yet been received in this city.

Introduce New Reproducer

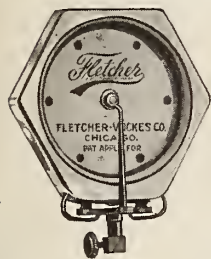

The Fletcher-Wickes Co., 6 East Lake street, this city, have recently introduced a reproducer constructed on entirely new principles for which the manufacturers present many important claims in their advertisement on page 39 of this issue. Its tone volume and quality has won high praise from

users as well as critical dealers and manufacturers who say that its future is well worth watching.

Close Vocalion Retail Store

In order to conform with the general spirit evidenced by the Government as to curtailment wherever possible, the Aeolian Co. has decided to close its Aeolian-Vocalion retail store in the Fine Arts Building, Michigan boulevard, Chicago. This move is also timely in view of the fact that the Aeolian-Vocalion line is receiving splendid retail representation in Chicago in the establishment of Mandel Bros. and other successful stores. The company believes that it can best co-operate with Vocalion dealers by conserving its resources wherever possible, and by closing its retail store in Chicago it will be in a position to enhance the value of the service rendered its dealers.

The Vocalion wholesale business in Chicago will be conducted as heretofore, and the tremendous increase in the demand for Aeolian-Vocalion products in this territory is reflected in the remarkable sales totals achieved by the wholesale division in Chicago. C. H. Addams, manager of the Vocalion store in Chicago, will join the wholesale Vocalion division with headquarters in New York.

E. C. COOK NOW GENERAL MANAGER

Elected to That Important Post in the World Phonograph Co., Chicago—New Jobbers

CHICAGO, ILL., August 10.—E. C. Cook, who has had many years' experience in marketing products in and out of the music trade, has been elected secretary and general manager of the World Phonograph Co., and since assuming his new position has succeeded in signing up over twenty new jobbers all over the country, as distributors for the World Phonograph Co.'s line. All the concerns are prominent and substantial, as will be seen by the list in the company's advertisement in The World this month. Mr. Cook is 100 per cent. American, and the policy of the company will be distinctly on that basis.

WESTERN NEWS CO. ENTERS FIELD

Great Concern Introduces Tel-o-Tone—W. Cheney Beckwith Has Achieved Unique Acoustic Features in New Designs of Talking Machines

CHICAGO, ILL., August 8.—One of the biggest announcements of the month fraught with big news of the Western talking machine industry is that of the entrance into this field of the Western News Co., a concern long known the world over for their line of newspapers and magazines and all that pertains thereto. This great house with its various ramifications represents a vast investment. The Tel-o-Tone, as the new machine is known, has not sprung into life instantly like Minerva from the brain of Jove. That was fable. This is fact. The idea had long been in the mind of W. Cheney Beckwith, an old piano man and acoustician of distinction, one who had been working faithfully and honestly along both theoretical and empirical lines for about seven years. Further details than those contained in the company's advertisement in this issue will be given later. A glance at the picture in the announcement,

however, will show that the spirit of harmony has been preserved both in the exterior and interior of the machine.

L. A. Neis, the manager of the Chicago branch, has put his whole heart and soul into the proposition, while J. W. McCormick will look after the management of the talking machine department. He is a man well equipped to direct its distribution through long flowing channels. The Tel-o-Tone is being manufactured under the supervision of the inventor. "The soul of music" is one of the aesthetic slogans used in connection with the machine.

NEW POST FOR A. W. ROOS

Appointed Acting Manager of St. Louis Branch of Columbia Graphophone Co.

George W. Hopkins, general sales manager of the Columbia Graphophone Co., New York, announced recently the appointment of A. W. Roos as acting manager of the company's St.

Louis branch, succeeding Irby W. Reid, who has recently resigned from the Cleveland service.

Mr. Roos was formerly manager of the Cleveland branch of the Columbia Co., and has been identified with Columbia service for a number of years. He has won the esteem and friendship of Columbia dealers in Cleveland territory and he is receiving the hearty congratulations of his co-workers upon his appointment.

J. L. Dubreil, formerly assistant manager at the Cleveland branch, has been appointed manager in place of Mr. Roos. Although he has only been associated with the Columbia Co. for the past year, Mr. Dubreil has already gained an intimate knowledge of Columbia merchandising systems and plans, and his unceasing efforts to co-operate with Columbia dealers in Cleveland territory are justly rewarded in his promotion to the post of manager.

The Victrola and Sonora store of Louis Balaire in Le Mars, Ia., has been purchased by the Kehrberg-Schneider Co.

The **VITANOLA**



has everything in its favor. When you take on the Vitanola agency you haven't signed up for a "white elephant"—you have entered into a contract that will make you some money.

Right now our proposition can't be beat—we're making immediate deliveries. That in itself should be sufficient notwithstanding the fact that we are producing a super-phonograph.

Get in touch with us at once and get this valuable agency while there is opportunity. It will make you some good money.



Trade Mark Registered

VITANOLA TALKING MACHINE CO.
501-509 W. 35th Street - - - CHICAGO, ILL.

**Buy the World Phonograph
You'll Confess It's the BEST**

Ernest C. Cook

Has been elected Secretary
and General Manager of the
World Phonograph Co.

Mr. Cook is 100 per cent
American and that is the
policy of this company.

Write for our beautiful illus-
trated catalogue of new
designs.

WORLD PHONOGRAPH CO.

736 TILDEN STREET, CHICAGO, ILLINOIS

We are one of a few who manufacture our Cabinets Others buy them.

SOME DISTRIBUTORS

Hibbard, Spencer, Bartlett & Co., Chicago.
Marshall, Wells Co., Duluth, Minn.
Peden Iron & Steel Co., Houston, Tex.
Janney, Semple, Hill Co., Minneapolis, Minn.
Richards & Conover Hdw. Co., Kansas City, Mo.
Wyeth Hardware Co., St. Joseph, Mo.
L. E. Lines Music Co., Springfield, Mo.
J. S. Merrill Drug Co., St. Louis, Mo.
J. W. Edgerly & Co., Ottumwa, Ia.
Crescent Music Co., Fort Dodge, Ia.
Stirtch Hardware Co., Center, Col.
Larson Hardware Co., Sioux Falls, S. Dak.

Orgill Bros. Co., Memphis, Tenn.
A. Baldwin Co., New Orleans, La.
McGowan, Lyons Co., Mobile, Ala.
Boetticher-Kellog & Co., Evansville, Ind.
Bartlett-Jennings Co., Lynchburg, Va.
Knapp & Spencer Hardware Co., Sioux City, Ia.
Ault Woodenware Co., Cincinnati, O.
Gray & Dudley Hdw. Co., Nashville, Tenn.
Louisville Tin & Stove Co., Louisville, Ky.
Lee Hardware Co., Salina, Kans.
J. D. Weed & Co., Savannah, Ga.

PROTEST WAR TAX REFERENDUM

Jobbers' Association to Make Strong Protest Against Chamber of Commerce Committee's Recommendation for Heavy Tax on Victrolas—Charges Discrimination in This and Other Matters—Willing to Bear Just Burdens

The members of the National Association of Talking Machine Jobbers are much incensed over the referendum recently sent out by the Chamber of Commerce of the United States upon the recommendation of its Committee on Financing the War, suggesting that both consumption taxes and so-called "luxury taxes" be placed upon a few articles, and that they be made heavy, rather than light taxes be put on a large number of commodities. The committee in its recommendation included in the list of articles classed as "luxuries" musical instruments and worded that section of the recommendation to include "victrolas and various other mechanical musical appliances." The talking machine jobbers, through their president, J. Newcomb Blackman, referred to the action of the committee as being vicious, eminently unjust, and savoring of bald discrimination, for, as it is pointed out, but one make of talking machine has been selected for taxation from among the many in the field, and that—and this is the sore point—the recommendation is made to apply to Victrolas and various other mechanical musical appliances instead of to musical instruments as a whole.

Talking machine men have not forgotten that in the drafting of the last War Revenue bill the burden of taxation was placed on talking machines and records and upon the music rolls and player actions only used in the player-piano, leaving pianos of all kinds, as well as dozens of other types of musical instruments, scot free. It is the plan of the jobbers and others in the industry to see that such a discrimination does not crop out again. The lively protest against the wording of, and recommendation contained in, the referendum sent out by the Chamber of Commerce of the United States is heralded as the first step in the fight to get a fair deal for the trade.

It has been pointed out by those interested that the very phrasing of the recommendation indicates that the committee was not familiar with the industry and its ramifications—despite the fact that one of its members is believed to have had sufficient experience with the trade to know what are Victrolas and what are not—and being in ignorance regarding the industry, were not qualified to, and therefore should not, have made recommendations as to its classification under the proposed Tax Law. Inasmuch as the National Association of Talking Machine Jobbers has for some years enjoyed membership in the Chamber of Commerce of the United States, its members feel that they are well within their rights in questioning the authority of the committee to make recommendations of such a radical nature. The attitude of the association has been set forth strongly by J. Newcomb Blackman, president of the National Association of Talking Machine Jobbers, to Elliot H. Goodwin, secretary of the Chamber of Commerce of the United States, in which Mr. Blackman takes exception to the attitude of the Committee on Financing the War in its recommendation for high taxes on certain classes of so-called luxuries, and particularly to the evident discrimination shown, probably through ignorance, when Victrolas were selected for special mention. (Letter appears on page 86.)

Regarding the suggestion that heavy taxes be placed upon a few articles, rather than light taxes on many, Mr. Blackman expressed the sentiment of the association as being in favor of the raising of the required War Revenue by placing small taxes on a large number of industries, and thus permitting all to stay in business, rather than by placing prohibitive taxes on a few selected industries. He pointed out that heavy revenues desired from certain lines of industry cannot be realized if the taxes

The
CHENEY
PHONOGRAPH

"Plays all records better"

Dealers

are invited to inspect this instrument which is so distinctly different from all others.

Attractive agency proposition. Liberal advertising plans.

Write for catalog and full particulars

H. L. ROYER
New England Representative

77 SUMMER STREET, Room 59 - - BOSTON

designed to produce that revenue are so heavy as to practically wipe out the industry in a comparatively short time.

It is emphasized that a 20 per cent. tax on the selling price of a talking machine, as suggested by the committee of the Chamber of Commerce, would mean on the average discount basis a tax of 40 per cent. on the manufacturer's price, or over a 1,300 per cent. increase over the present tax at one jump. The 10 per cent. tax on the manufacturer's selling price, as favored by the Ways and Means Committee of the House, is regarded in a more favorable light.

"It would be well," said Mr. Blackman, "if the excise taxes generally worked out on the basis of those taxes that apply to incomes and as they are designed to apply to clothing and other lines. On that basis the man who is making just enough to live on is exempted. Next, the man who has a more substantial income above his actual necessities is taxed a small percentage. Then there is the surtax for the man with the big income. In other words, all men do not come under one general classification, which would prove burdensome to some and extremely light to others, but each in-

FRANK K. PENNINGTON RETURNS

Frank K. Pennington, assistant general sales manager of the Columbia Graphophone Co., New York, returned to his desk Monday after a visit to the Columbia branches at Cincinnati, Cleveland, St. Louis, Chicago, Minneapolis, Kansas City, Indianapolis, and the Columbia jobber in Omaha, the Schmoller & Mueller Piano Co.

Commenting upon general conditions in this territory Mr. Pennington stated that it was very largely a question of product in practically every city he visited. The demand for Columbia product is far beyond the supply, and Columbia dealers everywhere are preparing for a banner fall trade. The present Columbia advertising campaign is meeting with the general approval of the dealers, and there is a spirit of optimism and enthusiasm regarding the future that is very encouraging.

The Pershing message upon a Columbia record, which was introduced a few weeks ago, is meeting with signal success, and the Columbia dealers state that this record will undoubtedly be included in the library of every patriotic music lover throughout the country. Crops in the West are in excellent shape, people have plenty of money, and Mr. Pennington states

dividual finds himself in a special class according to his status in the scale of incomes.

"The taxes on articles of clothing, as suggested, are also on a fair basis. If a man must buy shoes, he can spend up to \$10 for those shoes without being liable to taxation. If his income and station in life, however, demand that he spend over \$10 for shoes, then he places himself in a class that must pay taxes on that added luxury. On this basis, it is hard to understand why a \$20 Victrola should now be taxed at the rate of 3 per cent. on its wholesale price, and probably more in the near future, when pianos selling for several hundred dollars are left free from taxes of any sort. Isn't the poor man just as much entitled to his \$20 Victrola free of tax as the rich man is to his \$500 piano?"

The talking machine men make it plain that they are perfectly willing to stand an equitable tax without protest, and are ready to do their full patriotic duty towards the winning of the war, but they do feel that if musical instruments are to be taxed the burden should be divided among all musical instruments and not simply assessed on talking machines and one or two other items.

there is every reason to believe that the West will enjoy an era of prosperity that will withstand all abnormal industrial conditions.

BRUNSWICK LINE FOR BAMBERGER'S

It is announced that L. Bamberger & Co., big department store in Newark, N. J., which has for some years conducted a very successful piano and talking machine department, has taken on the Brunswick line in that city.

A MUSICAL ACCIDENT

The Deckers were entertaining callers. Suddenly there was a loud bump and a wild wail. It came from the direction of the piano.

"Oh, Earl, the baby has hurt himself!" cried Mrs. Decker. "Run quick, dear."

The young father had already dashed toward the piano. He dropped on his knees and groped under the piano for his injured offspring. Presently he returned.

"He fell down and bumped his head on one of the pedals," he reported.

"Oh, the poor darling! Is it a bad bump?" asked one of the guests.

"No," he answered, "fortunately his head hit the soft pedal!"—Harper's Magazine.

“The Stay-at-homes”



FOR some of us it is written in the order of the day that our classification is among the “stay-at-homes”; to follow our daily work and to do our bit here—here at home, rather than “over there.”

For we in this organization who have that classification, there is one compensating thought. The thought that our product is used in phonographs which are in the camps, in the Y. M. C. A. huts, by the Red Cross, and in the homes that the boys have left behind. And in this thought there is the satisfaction that we are offering an honestly built, precision-made product. One which will give maximum service with minimum attention, whether in the quiet of the home or subject to the rough usage of the camp.

Cordially yours,

A handwritten signature in cursive script that reads "Frank V. Nutze".

Vice-President

STEPHENSON, INC., One West 34th Street, New York

Manufacturers of the Stephenson Precision-Made Motor

STRADIVARA ART PHONOGRAPH

Handsome Display Made by the Compton-Price Co. in Special Advertisement in This Issue

The Compton-Price Co., of Coshocton, O., manufacturers of the Stradivara Art Phonograph, are deserving of sincere congratulations on the very artistic supplement of their beautiful line of talking machines which appears elsewhere in this issue of The Talking Machine World. They are certainly most attractive creations, admirably balanced architecturally and by reason of their individuality of tone and construction they are destined to win a large appreciation.

This company are inaugurating an active campaign for the coming fall, and have just prepared some elaborate catalogs which set forth the especial merits of these instruments in detail, and which combined with advertising service and sales assistance to dealers, who are exclusive in each locality, these instruments should win a large measure of favor from the public.

The Compton-Price Co. are believers in the potentiality of publicity and which with the merits of their instruments must unquestionably win for them a standing of importance and dignity in the industry in due course. We understand that there is some unfilled territory which will not be long open, judging from the increasing line of agents who are going on record as representatives of the Stradivara line.

JOHN McCORMACK'S WORK IN WAR

Noted Tenor in Red Cross Magazine Tells of What Music Means at the Present Time

The leading article in the Red Cross Magazine for August is in the form of an interview with John McCormack, the noted tenor, by Heywood Brown, the introduction to which pays a stirring tribute to Mr. McCormack's services in lending his voice to the cause of the Red Cross and other war movements. The singer's successful efforts in raising \$100,000 for the Red Cross on his recent tour and his further efforts in behalf of the Knights of Columbus Fund and other movements are too well known to require comment. Regarding his war work, and incidentally the essentiality of music, this noted Victor artist said in part:

"No man could hate Germany as sincerely as I do and stay out of the war, and no man could believe as I do in hard fighting, and in everybody's fighting, and not want to hit where he could hit hardest. I could have gone to a recruiting station and enlisted as a private, but I believed in music too much as a war measure to be willing to abandon it, if I could assist.

"So I took my problem to President Wilson. I told him that I offered myself unreservedly, that I would serve wherever I was placed, but that I did not think music was a non-essential, and that if I could serve in that department I would give myself as thoroughly and untiringly as any soldier in France. And the President said: 'I would far rather have you as a singer for the war than as any other kind of a soldier . . . We can't all do the same thing . . . and some one must keep the fountains of sentiment flowing. . . .'

"So that was how I enlisted. I am serving still. I am waiting for orders now. The Red Cross tour as I planned it is just finished, and I went over the hundred thousand I had set for myself. But that's only one job—there will be others.

"Nobody must feel that music is among the non-essentials. The world needs it more when it's in trouble than at any other time. And soldiers, and the mothers and wives and sweethearts and children of soldiers get more of the breath of life from it than the man in the street has any notion of."

Kimberly Phonograph Co., Inc., Manhattan, was incorporated this week with a capital of \$20,000 by M. Salter, H. C. Klonka, H. V. Kirkman, 206 Broadway.

VACATION TIME IN PORTLAND, ORE.

Members of the Various Staffs Gathering Up Energy for Lively Fall Business

PORTLAND, ORE., August 3.—Many of the employees of the Portland talking machine houses are on vacations at present, and those remaining on the job have found plenty to do, as there has been no let-up in business as usual for the summer months.

Miss Rae Holmes, of the Columbia Graphophone Co. branch, Dictaphone department, has just returned from a vacation to the Coast. Louis Older, assistant manager, and Mrs. Older, cashier, have returned from a trip to Mount Hood summit and Tom Cooney has returned from a vacation. L. H. Kebbe, of the Columbia Dictaphone department, was taken in the draft, leaving for Camp Lewis July 25.

Paul B. Norris, of the Wiley B. Allen Co. department, caught forty-eight brook trout on a recent fishing trip with a crowd of friends. He looked greatly refreshed after his outing.

W. E. Henry, representative of the foreign record department of the Columbia, has been visiting in Portland on his way South. Mr. Henry says the foreign record department is particularly good on the Pacific Coast on account of the influx of many foreigners to the shipyards. This Coast is especially strong in Scandinavian language.

Miss Jessie Meighen, of the Hyatt Talking Machine Co., has been enjoying a two weeks' vacation at Seaside, Ore. C. A. Alphones, of the Hyatt Co., is visiting Seattle, Tacoma and other Washington cities.

Portland is having the advantage of hearing Miss Lucy E. Cole, representative of the Columbia Co. Miss Cole is lecturing at the different summer schools in Portland and has lectured at Reed College, Oregon Agricultural College, Oregon State Normal School and the Y. W. C. A. She has been explaining methods and merits of using the Grafonola in school work. She leaves for San Francisco from here.

EXECUTIVE COMMITTEE TO MEET

Jobbers to Hold Sessions in Philadelphia Some Time in September

It is announced that preparations are now being made for the holding of a meeting of the executive committee of the National Association of Talking Machine Jobbers in Philadelphia some time late in September for the discussion of existing conditions and problems in the trade, and other matters that would ordinarily have come up before a general convention had there been one this year. Dates for the meeting have not yet been definitely fixed.

THREE PHONOGRAPHS AS PRIZES

Flatbush Music Co., Brooklyn, N. Y., Stimulates the Selling of War Savings Stamps

The Flatbush Music Co., Brooklyn, N. Y., have aroused much patriotic interest in their section of the city by offering three Brunswick phonographs as prizes for the three people who sell the greatest number of War Savings Stamps in Flatbush during August. The offer is not only stimulating the sale of the stamps for the benefit of their Government in the prosecution of the war, but is likewise attracting profitable attention to the store and business of the Flatbush Music Co.

VACATION DAYS IN FORCE

These are vacation days for the members of the phonograph department at the local Brunswick-Balke-Collender Co. headquarters. Although Edward Strauss, sales manager in the East, will forego his vacation, others of the staff have enjoyed, or will enjoy, a respite from business cares. S. Byerley, retail salesman, is going away for a fortnight, and H. D. Clark, Newark representative, has just returned from a two weeks' rest. Chester Abelowitz will take his vacation in calling on the trade in Connecticut.

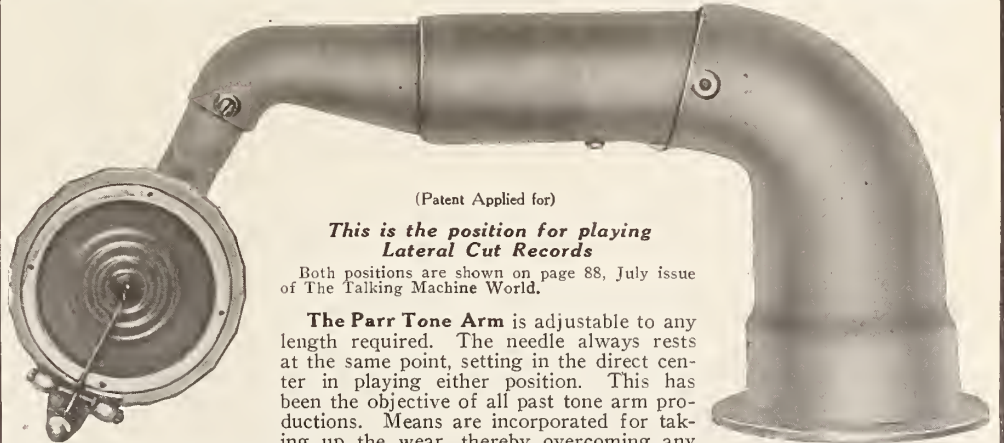
THE PARR CENTRAL UNIVERSAL TONE-ARM

(Patent Applied for)

This is the position for playing Lateral Cut Records

Both positions are shown on page 88, July issue of The Talking Machine World.

The Parr Tone Arm is adjustable to any length required. The needle always rests at the same point, setting in the direct center in playing either position. This has been the objective of all past tone arm productions. Means are incorporated for taking up the wear, thereby overcoming any

tendency for loose joints, which is the chief cause of "chattering."

The design of the tone arm permits perfect playing of either type of record without additional attachments. The sound box can be turned, allowing the needle to be changed with ease, and by a reverse movement the box returns to its normal playing position.

Parr Magnetic Reproducer fitted with the Vibratone Patent Diaphragm

The most sensitive of reproducers. The permanent magnetic device, an integral part of the reproducer, acts on the stylus box. Its possibilities in giving warmth and delicacy in the tonal reproduction of quiet passages make old-style sound boxes seem obsolete. And in fortissimo passages where ordinary reproducers create unpleasant, music destroying blasts, caused by the needle jumping and losing its grip, the Parr Magnetic Reproducer, with its marvelous flexibility, follows every wave and vibration in the record and takes everything the record holds.

The indestructible, non-crystallizing, always resilient Vibratone Patented Diaphragm

Possessing all the good points of mica diaphragms, it overcomes all mica's bad features. Guaranteed uniform in quality, free from bubbles, blisters and waves, the Vibratone Patented Diaphragm is non-porous, non-absorbent.

It has a definite function and it performs it. It improves tone; in fact it creates new tone possibilities for every reproducer of other types.

PARR MANUFACTURING CORP.
ONE UNION SQUARE . . . NEW YORK



COLUMBIA SERBIAN RECORDS

Those Made by the Serbian Native Tamburiza Orchestra Win Much Favor—More Records to Be Found in October List

Advance orders received from Columbia dealers throughout the country indicate that the record made by the Serbian Native Tamburiza Orchestra, which was introduced in the September supplement, will achieve a remarkable success. This record was originally made for the foreign language record library exclusively, but music critics after listening to it, stated that it would undoubtedly meet with popular favor if introduced in the general catalog. The record



Serbian Native Tamburiza Orchestra

was accordingly announced in the September list, and Columbia representatives are so well pleased with it that they have already requested the Columbia foreign language record division to issue additional records by this orchestra as soon as possible.

In the October supplement another foreign language record will also be announced to the general trade, this record consisting of two se-

lections made on a novelty circus organ that is popular in Holland. This circus organ record features "Puppchen" and the "Shadow Waltz," and the individual musical qualities of this instrument will undoubtedly appeal to many music lovers.

THE ART OF SELLING GOODS

Some Pointers Regarding the Basis of Salesmanship Which Are Worth Considering

Salesmanship is based on knowledge and confidence.

- Knowledge of your particular business.
- Knowledge of your goods.

Knowledge of human nature.

Confidence in yourself.
Confidence in your
house, and the goods you
sell.

Knowledge is power.
If you know more about
your business and the stuff
you are selling than your
competitor does, you have
at once placed a handicap
upon him, and should

easily succeed while he does not. Every man who is selling goods, whether it be the lawyer or the physician whose skill is his stock in trade; the farmer or the miner who markets what he raises from the soil, or digs out of the bowels of the earth; the railroad or steamship manager whose traffic is human lives and tons of commerce; or the manufacturer, jobber or retailer, who represents the class we more commonly

think of when we speak of selling goods—each and every man should make his own business his object of constant study and investigation, and it should be his pride and ambition to know more about the particular thing he is doing than any other living man.

J. NEWCOMB BLACKMAN PROTESTS

President of National Association of Talking Machine Jobbers Writes Timely Letter to United States Chamber of Commerce

NEW YORK, August 13, 1918.

Mr. Elliot H. Goodwin, Secretary,
Chamber of Commerce of the United States,
Washington, D. C.

Dear Sir: As president of the National Association of Talking Machine Jobbers I recently analyzed Referendum No. 25, containing the report of the Special Committee on Financing the War, and I am surprised that the most influential organization of business men in the United States should express themselves through a special committee as they do in recommending that Question 9 be voted in the affirmative specifically as presented on page 9, concerning luxuries "so-called."

Under date of July 19 last I expressed to our national councillor my firm belief that these recommendations are not only unwise and unfair to the talking machine industry, but to the entire allied musical instrument trade. It is without hesitancy that I state for our own association, as well as our business, represented by manufacturers and wholesale and retail dealers, that a tax of 20 per cent. levied on the retail selling price would not produce increased revenue, but curtail to the point of bankruptcy in many cases. This position can be realized when you compare the proposed tax with the present one of 3 per cent. on the manufacturer's selling price and what a tremendous advance it would mean with a tax of 20 per cent. figured on the retail selling price.

Our protest is that this proposed tax is extremely excessive and that it would not produce increased revenue, but would be very successful in killing industry. The August 10 issue of The Music Trades, on page 16, contains an article giving publicity to the protest from this paper and one of its correspondents, as well as a letter from you, in which you claim that the special committee of the Chamber of Commerce has been unfairly attacked. The exhibit headed "The Deadly Parallel" fully justifies in my mind the complaint, whereas your answer, at the best, represented by your letter addressed to the editor of The Music Trades, under date of July 30, is an attempt to hide behind an interpretation that would discriminate in favor of some musical instruments, while putting the burden of the tax on one particular type named specifically by the word "Victrolas." The editor's retort to you, in which he calls attention to the apparent lack of information on the part of the committee, is a point well taken, for "victrolas" does not represent a generic word, whereas "musical instruments" would. Victrolas are the product of one concern only—the Victor Talking Machine Co.

Furthermore, you and the committee seem to take the position that you are merely following France in handling taxation in this manner. May I, therefore, ask you to refer to page 19, and the twenty-six articles referred to, for I fail to find the word "victrolas" or "musical instruments," nor do I see introduced the qualification "mechanical." Broadly speaking, and in a spirit of fairness to all manufacturers and sellers of musical instruments, I think we can reasonably take the stand that music should not be suppressed in the manner indicated by the opinion of your special committee.

The Secretary of the Treasury, in his statement, also published in this referendum, concludes by recommending that taxation be imposed on all "luxuries." When your committee undertakes to define "luxuries" and then says "many articles which are clearly luxuries, etc.," they are assuming to be qualified to pass on and interpret this much mooted question in a manner that so far our highest Government officials have hesitated to do. Furthermore, to present, as one of the reasons for selecting a few victims among so-called luxuries, the one that "collection is simplified" is hardly a constructive reason, nor one that will be regarded as fair. In the Secretary of the Treasury's recommendations he has first in mind the urgent need of raising revenue, and that is the prime object of the new revenue bill, so when the committee disregards his recommendations by selecting a few articles, instead of a large list, the effect is to be deplored from the standpoint of failure to produce the necessary revenue, regardless of its fairness.

Referring to the word "mechanical" as defining the kind of musical instrument to be taxed, may I not call your attention to the fact that this would be discriminating against talking machines, and an educational system, the value of which is recognized to-day by the installation of Victrolas alone, with special educational records, in from 35,000 to 40,000 public schools in over 6,500 towns and cities in the United States. These instruments are teaching music and inspiring pupils through the rendition of it by the world's most famous artists. Then again, investigation will clearly disclose that there is hardly a transport, naval vessel, cantonment, base hospital, Y. M. C. A., Red Cross, Knights of Columbus, or Salvation Army headquarters or camp that is not using a talking machine as one of the necessary parts of its equipment, and appeals are being received daily for the donation of records to cheer and inspire our enlisted men. It is the mechanical operation of these instruments that makes their value for these purposes immediately available and more widely possible, without musical training or talent on the part of the operator. Therefore, it seems to me there is no "luxury" or "non-essential" represented in musical instruments so used, and an unreasonable tax would be a blow at the use of these instruments as above.

The members of our association, through its executive committee, will vote vigorously against the recommendations of your special committee, as represented in Question 10, and it is unfortunate that we will not be given an opportunity to be heard before the general membership of the Chamber of Commerce of the United States, in order that their vote might be cast, based on information which apparently the committee did not have, or they would not have treated our industry in such a discriminating manner.

Concluding, I feel justified in saying that the committee have disregarded the wishes of the Secretary of the Treasury, failed to do as they said in following the plan of our ally, France, in taxation, and have apparently, through lack of information, made recommendations which have made necessary a protest from the entire allied musical instrument industry. I hope there is yet some way to correct this error, for surely it is the desire of all to bear our just share of taxes without discrimination or protest. If you will favor me with an early reply, it will be greatly appreciated. Very truly yours,

THE NATIONAL ASSOCIATION OF TALKING MACHINE JOBBERS,
(Signed) J. NEWCOMB BLACKMAN,
President.

Operaphone Records

Ten Inch Retail 75 cents

The popular standard American catalog dealers have been waiting for.

We know you must have records.

Operaphone Records follow the line of least resistance, they play with steel needle on all universal tone arm machines with sound box facing front.

Order direct from Long Island City or from your machine jobber.

Send for our trial package assortment including window display and regulation catalog book.

Operaphone Co., Inc.
LONG ISLAND CITY, NEW YORK

PROSPERITY PREVAILS THROUGHOUT PORTLAND TRADE

Growth of Shipbuilding Industry Has Increased the Purchasing Power of the Masses—Talking Machine Merchants Feeling This Influx of Wealth—General News of Interest

PORTLAND, ORE., August 6.—Trade has been especially good in the talking machine field and dealers are looking forward to means to augment the stocks depleted by the heavy buying which they attribute to the unwonted prosperity of the city where shipbuilding has sent wages soaring, where the payroll has been increased by hundreds of thousands of dollars each week with an influx of 35,000 shipbuilders and other workers due to the sudden increase in population and labor.

Perhaps no store in Portland has benefited more by the business revival than has the Wiley B. Allen Co., which is not only doing a greatly increased piano business, but which has more than doubled its normal summer talking machine and record trade. Edison and Victor machines have been featured at this house, which has had an especially attractive window display built around a portrait of Thomas A. Edison, painted by a Portland artist. A number of Cowan Classics, recently added to this firm's list, have been on display also.

Ten Victrolas were shipped to the spruce division by the Wiley B. Allen Co. this week. Paul B. Norris, in charge of the talking machine department, says the order for the Victrolas came directly as the result of a patriotic window display. Mrs. Olga Binder, in charge of the record department for Wiley B. Allen, says she is busy getting stock in shape for fall when a big business is expected.

The Hyatt Talking Machine Co. will move into new quarters September 1. The present store has been taken by the Northwestern National Bank, which has purchased E. B. Hyatt's lease. Mr. Hyatt has leased for a period of two years a store 25 by 100 feet in the new Rialto Building. The new store has a fine basement and mezzanine floor. Eight demonstrating rooms will be installed and three machine salesrooms in addition to the office.

LOS ANGELES DEALERS FIND IT HARD TO GET RECORDS

Growth of Patriotic Sentiment Has Stimulated Sales of Records Tremendously—Small Machines Also in Favor—Taboo on Music of German Origin—H. N. McMenimen a Visitor—About Exports

LOS ANGELES, CAL., August 6.—July has fully lived up to expectations and business has been very good in Los Angeles. Of course, there is generally a slowing up in sales during the summer months and this year has been no exception.

The many outfits being sent to the soldiers and sailors by the Red Cross, etc., have been a great help to the trade in general and large orders for records are being received now from the various cantonments who have already purchased or been given a machine.

The sale of small machines has been very gratifying so far as many of these are traded in later for larger models.

Most of the local dealers are still having trouble in getting enough records. In fact, lots of selections, especially the older recordings, cannot be obtained from any jobber.

Some uneasiness has been felt in trade circles over the report from Washington, D. C., that a considerable revenue tax was to be levied on all future purchases of talking machines, but most of the merchants realize that this is a matter that cannot be helped and which will work itself out to the satisfaction of all and be of great financial benefit to our Government during the duration of the war.

The demand for music of German origin, even the compositions of the older masters, has been decreasing steadily in Los Angeles since the U. S. entered the world war, and the local Musicians' Union has even gone so far as to place a fine of \$50 on any orchestra playing a piece of music composed by a German or having a German title.

Charles Moore, traveling representative for the Ross P. Curtis Co., Victor jobbers at Lin-

The Wakefield Music Co., which sells the Brunswick talking machine and Pathé records, has been doing a good summer business. C. Guy Wakefield, manager, says many shipbuilders are buying Brunswicks as a result of his sending to the shipyards 16,000 circulars advertising this machine. Miss Flora M. Wakefield, daughter of the manager, has taken charge of the record department.

Large sales of Columbia and Victrola machines are reported from the Meier & Frank Co. J. H. Matney, proprietor, sold \$1,026 worth of machines the other day.

Miss Ruth Le Van is now connected with the record department of the Meier & Frank store.

Harold S. Gilbert, of the Gilbert Piano Co., is selling quite a number of Columbia Grafnolas. The new non-set machines have proved very popular and have sold readily. The Columbia Co.'s Portland branch is also having a big run of the new machines, which are being displayed to dealers and customers who manifest great interest.

Sonora machines are selling unusually well at the Bush & Lane store. James Loden, manager of the talking machine department, is busy rearranging his stock. He expects a shipment of Sonoras of period designs in the very near future and anticipates a large sale.

The phonograph department of the G. F. Johnson Piano Co. will be enlarged and improved in the near future. Larger display rooms on the mezzanine floor and more record rooms will be added. Robert T. Callahan is manager of the talking machine department.

L. E. Gilham, manager of the Stradivara Co., says that business is splendid with the trade unusually satisfactory. He has just sold a handsome Stradivara grand for \$250 to a prominent Portland family. Mr. Gilham is establishing a lot of new agencies through the country and is putting new men on the road.

coln, Neb., has been stopping in Los Angeles for the last week.

William Hobbs Richardson, manager of the talking machine department for the Southern California Music Co., reports an incident that may be of interest to the trade in general. They received an order for records from Mexico; the order was filled and sent out by parcel post in the usual manner, but was held up by the Customs Censor, who declared he would not pass on them until he had heard them played. One of the clerks took a Victrola to the Federal Building and played the records for the official and when finished was charged 35 cents, being for the time it took the censor to listen to them. This shows how particular the Government is in examining everything before it leaves this country.

H. N. McMenimen, managing director of the Pathé Frères Co., is on a trip of inspection to the Coast and spent several days in Los Angeles looking over the situation here. He is very enthusiastic over the future of the Pathé products and expects to establish many new agencies in this section of the country before returning East.

MUSIC AND THE FIGHTING MAN

J. K. Nichol, formerly connected with Thomas A. Edison, Inc., and now in the United States Navy, in a recent letter to the Edison people points out the wonderful value of the phonograph in navy and army camps, and says that there should be a machine in every one of the ship's quarters, as well as in training stations, and says that the phonograph is a tremendous educator and stimulator of patriotism.

"A WONDERBOX OF MUSIC"

British Correspondent Thus Describes the Talking Machine at the Front—An Excellent Editorial on Important Subject

In connection with the accompanying expressive cartoon, the Evening Express, of Los Angeles, Cal., recently published the following editorial comment that should prove of more than usual interest to members of the trade generally, as indicating a new attitude toward the talking machine:

"Whether the phonograph is regarded as a

HELP ROUT HIM

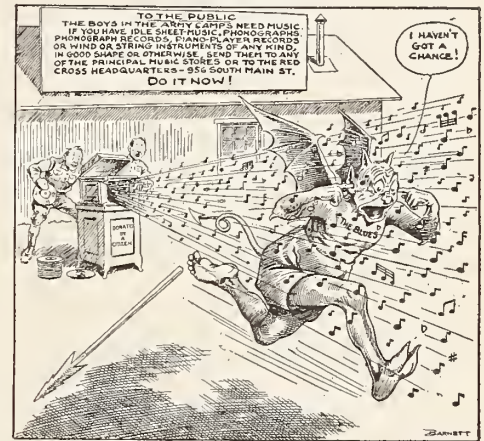

A Timely Cartoon

toy or a nuisance, it has found a place of honor in the army. Every center of recreation behind the front has its instrument and assortment of records. The canteens, the hospitals, the Y. M. C. A. huts and kindred auxiliaries all rejoice in their phonographs.

"A correspondent of the London Mail reports:

"To-day the phonograph at the front is a wonderbox of music, an inexhaustible source of good cheer and melody. Not merely that, but any padre will tell you that it is one of the greatest influences for good that can be found. It gives the boys a musical home. Never mind whether it be standard ballad or overture or the latest comic song. It is sunshine music and brings with it thoughts of home."

"There is good reason for the appeal the American Red Cross is making for contributions of talking machine records of all sorts. Not only that, but phonographs of every make are in demand and small musical instruments of every kind.

"The local organization is active in this campaign and has received the co-operation of Los Angeles music houses, that have volunteered to repair all machines or instruments and pack, with records, for transportation.

"There must be hundreds of homes in Los Angeles that can give helpful aid to this meritorious campaign. The talking machine department of any of the principal music stores will receive phonographs, records or musical instruments or they may be sent to Red Cross headquarters at 956 South Main street."

QUALITIES WORTH CULTIVATING

Professor Walter Dill Scott says that most difficulties are difficulties because complete information is not at hand to be worked on. A habit of close observation oftentimes enables one to get necessary information which, put down on paper, is then before him for reference. After securing complete information, concentration is the proper method of attacking the problem. To develop concentration do one thing at a time—the right thing. Don't allow several items to crowd the main issue. Regularity is a secret of forming habits of concentration. Do the same kind of thing in the same place at the same time each day for a period and less effort will be required to concentrate upon it. Will power is a matter of inheritance and environment, largely of environment. It can be developed. Educate it.

Have you bought a Thrift Stamp to-day?

Some Hints, Pointers, Suggestions and Valuable Facts Relative to

The instrument which provides the greatest amount of enjoyment at the most moderate outlay is the phonograph. As an entertainer and an educator it has no equal.

Many years devoted to the production of high-grade pianos has enabled the Bush & Lane Company to incorporate in the manufacture of the Cecilaphone every known feature and improvement necessary to the construction of a perfect sound reproducing instrument.

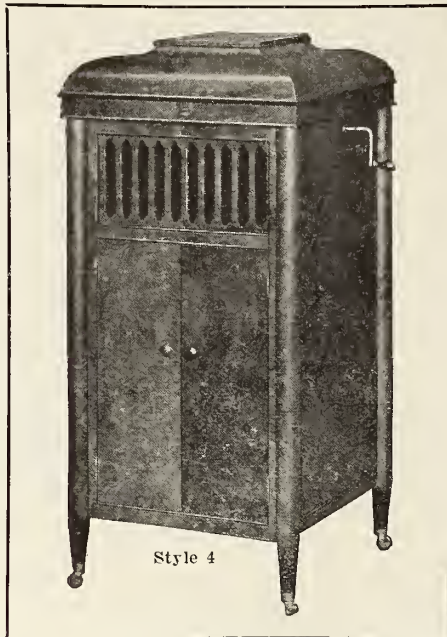

The essential parts of the Cecilaphone—sound box, tone arm, sound chamber, tone modifier and motor—have been constructed along scientific lines, with the object in view of obtaining the best and most artistic and therefore the most satisfactory reproduction of any and all records.

The Cecilaphone sound box is adapted to the reproduction of all records. In an upright position it plays lateral cut records, and by a quarter turn is adapted to the vertical cut or hill-and-dale type of records, which is but one of the advantages of this modern instrument.

The Cecilaphone Phonograph

Would it not be the part of wisdom and good judgment in the choice of a phonograph to select the instrument produced by experienced and fully equipped manufacturers—thus insuring the possession of "A Thing of Beauty and a Joy Forever"?

The tone arm of the Cecilaphone, by an ingenious process of casting, is adapted to amplify or swell the tones in their course toward the outer air. It is properly constructed and correctly balanced, enabling the busy needle to perform its work without interference.

The Cecilaphone Tone Modifier



Note the pleased expression on the fair face of the operator, as she turns a button in the side of the cabinet, by which she modifies the volume of tone, thus interpreting the selection being played in accordance with her own ideas of tone shading and expression. All models of the Cecilaphone are equipped with this original device, one of the pleasing features of this most pleasing instrument.

The Cecilaphone Tone Chamber

Limitations of space prohibit an adequate description of this most important part of the construction of the Cecilaphone. Suffice it to say, however, that in experimenting, designing and building it to fully serve its purpose, our long experience in piano manufacturing enabled us to get results undreamed of by those who lack such experience. It is made entirely of wood, the most responsive of all substances as a resonator of sound vibrations which produce musical tones.

Of greatest importance, this chamber has been scientifically shaped, and of the quality and grain of wood to best develop the proper response to vibration. The result can best be appreciated by hearing the instrument.



Can You? Could You? Would You? Will You? Take a Hint?

The Bush & Lane Piano Company
Manufacturers
Holland, Michigan

CALL ON MANY NOTED ARTISTS

E. N. Burns and Theo. Bauer Visit Summer Resorts Where Columbia Artists Are Sojourning—Toscha Seidel Greeted

Edward N. Burns, vice-president of the Columbia Graphophone Co., accompanied by Theodore Bauer, head of the company's operatic and concert department, visited several of the up-State summer resorts the early part of this



Toscha Seidel, E. N. Burns and Master Seidel month, in order to greet some of the Columbia artists who are summering in these places.

The first call was made at Lake George, N. Y., where Mr. Burns spent some time with Toscha Seidel, a young violinist, who recently arranged to record for the Columbia library exclusively, and who is accompanied by Professor



Miss Maurel, Mrs. T. Bauer, E. N. Burns, Theodore Bauer

Leopold Auer, internationally famous as a violin teacher, who is taking a keen interest in Mr. Seidel's future. Mr. Seidel has been acclaimed by critics as one of the most remarkable violinists introduced in recent years, and the Columbia Co. is planning to issue his first records in the near future. During his visit Mr. Burns prevailed upon Mr. Seidel to visit New York, in order to make additional records and to hear his first recordings.

The next call was at Schroon Lake, where Oscar Seagle, the famous operatic baritone and exclusive Columbia artist, is summering. Messrs. Burns and Bauer were accompanied to Schroon Lake by Miss Barbara Maurel, the well-known mezzo-soprano, who is also an exclusive Columbia artist, and who will make a joint tour this coming season with Oscar Seagle.

From Schroon Lake Mr. Burns and Mr. Bauer visited Lake Placid, where they met Madame Hulda Lashanska, prominent concert soprano, whose first Columbia recordings, recently introduced to the public, are meeting with pleasing success. Madame Lashanska was also prevailed upon to visit New York this month and make additional records, that will be announced very shortly.

TALKER RECORD CAUSES TROUBLE

A New York woman, who has applied to the courts for a separation from her husband, alleges in her complaint, among other things, that her spouse had the unpleasant habit of coming home and playing on the talking machine for a lengthy period of the record: "A Fool There Was," as an expression of his opinion regarding his marriage.

NEW YORK JOBBER BOUGHT OUT BY EDISON OFFICIALS

George L. Babson, Formerly General Manager of the Phonograph Corp. of Manhattan, Succeeded by Edward C. Boykin as General Manager—No Similar Action to Be Taken Elsewhere

The Phonograph Corp. of Manhattan, which has been conducting the magnificent Edison Shop at 473 Fifth avenue and for several years has jobbed the Edison line in New York City, has been taken over by individuals connected with Thomas A. Edison, Inc.

Henry B. Babson, former president, has been succeeded by William Maxwell, vice-president of Thomas A. Edison, Inc.; and Edward C. Boykin, formerly director of sales promotion for Thomas A. Edison, Inc., becomes successor to George L. Babson, as general manager. It is specifically stated by Mr. Maxwell that this change of ownership and management has no significance whatever except that the Edison Co. desires to see the New York jobbing business and the Edison Shop handled in a broader way than has hitherto been possible.

It is desired that this business will constitute an international advertisement of the Edison line, which, of course, would scarcely be possible so long as the control of the company remained in the hands of people whose interests were purely local. On this point Mr. Maxwell said recently:

"That we have had no disagreement with the Babson brothers is evidenced by the fact that they will continue to job the Edison line at Chicago, Milwaukee, Detroit and Kansas City. Nor have we any intention of eliminating our jobbers and establishing in their stead branch houses or subsidiary jobbing companies.

"We have always had covetous eyes on New York, and it was with considerable reluctance that we established an independent company as

our New York jobber. When the war is over New York is going to be pretty nearly the center of the world, and after careful consideration it seemed advisable to us to control our New York representation. New York City is visited every year by thousands of strangers whose attitude toward the Edison phonograph is largely influenced by the impressions they receive at the Edison Shop on Fifth avenue and at the wholesale headquarters down town. Naturally, we could not expect outsiders whose interests were confined largely to sales made in New York and contiguous territory to take more than a passive interest in a man from Kansas or Patagonia.

"We intend to operate the Phonograph Corp. of Manhattan not only as a New York distributor, but also as an active and painstaking ally of our jobbers and dealers throughout the United States. Our action in taking over the New York jobbing company does not signify any intention on our part of eliminating other jobbers.

"We are now handling the jobbing of the Edison line on the Pacific Coast and this with New York will make about all we care to handle. We shall be in very good shape to promote export business after the war, both to Europe and South America as well as the Orient. We have a beautiful retail store in San Francisco as well as commodious wholesale quarters at San Francisco, Portland and Los Angeles, and therefore have every facility on both coasts to receive foreign visitors and develop export business."

JOBBER VISIT EDISON FACTORY

C. B. Haynes, of the C. B. Haynes Co., Inc., Richmond, Va., and L. H. Lucker, of Minneapolis, well-known Edison jobbers, were recent visitors at the Edison factory in West Orange, N. J. Both these gentlemen had the same significant story to tell of conditions in their territory. Both reported an exceptionally good summer, owing to the consistently active canvassing engaged in by their dealers.

These identical statements, from two widely separated parts of the country, cannot fail to point a moral. They only serve to confirm the oft-reiterated statement made by officials of Thomas A. Edison, Inc., that summer is not

in itself a time of inevitably bad business. Dealers, many of them, have made it so by believing any efforts they might make to be hopeless, and consequently, through their inactivity, have created an artificial depression of trade.

The experience reported by Messrs. Haynes and Lucker shows graphically that dealers can avoid dull times in summer.

W. H. CALDWELL IN "Y" SERVICE

W. H. Caldwell, distributor of Starr phonographs and Gennett records, with offices and warerooms in Louisville and Shelbyville, Ky., announces that he will leave for France about September 15 in the interests of the Y. M. C. A.

IMMEDIATE DELIVERIES

Specials

FOR

Victrola IX



809

Mahogany. Golden Oak. Fumed Oak. Weathered Oak. Nickel-plated trimmings. Lock and key. Height, 33 inches. Top, 22 3/4 x 19 1/4 inches. Holds 192 twelve-inch records. Matches new Victrola IX. Highest type of cabinet, both in construction and finish. Average weight crated, 80 lbs.

WE have in stock other cabinets to fit all styles of machines and will be glad to send our catalog for the asking.



702

Mahogany. Golden Oak. Fumed Oak. Weathered Oak. Nickel-plated trimmings. Lock and key. Rubber-tired wheels. Height, 30 inches. Top, 17 x 20 1/2. Matches New Victrola IX. Top has countersunk holes to accommodate rubber bumpers on machine. Moulding on top securely fits base of machine. Average weight, crated, 75 lbs.

Schloss Bros.
635-37 West 55th St.
NEW YORK
Phone **Columbus 7947**

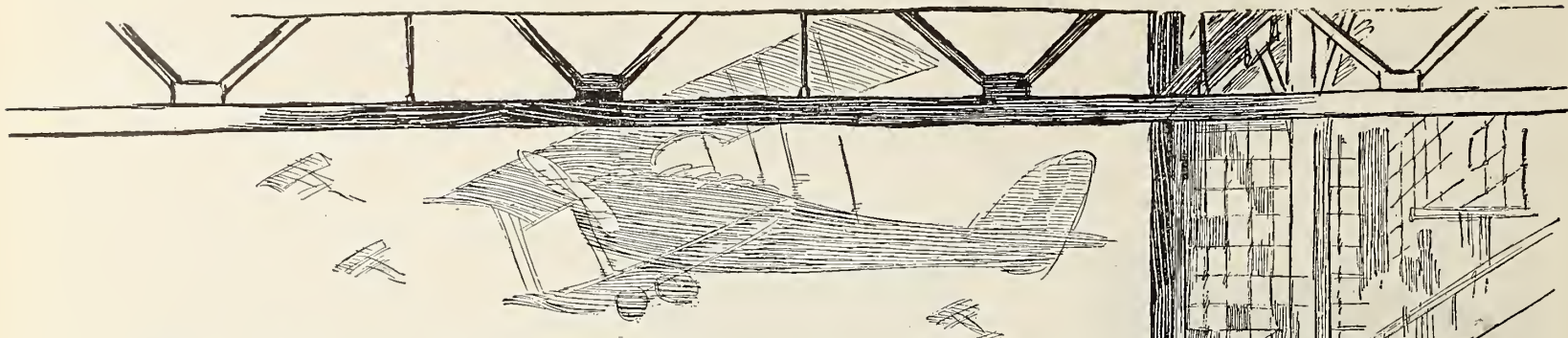

The Right Men in the Right Jobs Will Win The War

THE true American wants to work where he will help win the war. He wants to fit in. America needs the Right Men in the Right Jobs. Only when this comes about can maximum production be obtained to support our armies at the front.

The needs of all war industries can be anticipated and met by the Government if employers and laborers will avail themselves solely of the nation-wide machinery which is at hand. The length of the War depends directly on our Country's ability to supply all War Industry with the best workers the country can produce the moment they are needed.

The U. S. Employment Service is the official bureau of the Federal Government in charge of the distribution of labor. The President has declared that it is the official agency for recruiting and distributing unskilled labor for war work.

It has over 500 branches throughout the nation, and 20,000 U. S. Public Service Reserve enrollment agents. Ask the local post office or newspaper for name and address of the nearest representative, or write to the U. S. Employment Service, Washington, D. C.

PRESIDENT'S STATEMENT

"Industry plays an essential and honorable a role in this great struggle as do our military armaments. We all recognize the truth of this, but we must also see its necessary implications—namely, that industry, doing a vital task for the Nation, must receive the support and assistance of the Nation."

... ..

"Therefore, I solemnly urge all employers engaged in war work to refrain after August 1st, 1918, from recruiting unskilled labor in any manner except through this central agency [the U. S. Employment Service]. I urge labor to respond as loyally as heretofore to any calls issued by this agency for voluntary enlistment in essential industry. And I ask them both alike to remember that no sacrifice will have been in vain, if we are able to prove beyond all question that the highest and best form of efficiency is the spontaneous co-operation of a free people."

WOODROW WILSON.

Those employers in war work who seek to get labor through their own or private recruiting agencies are interfering with the Government's machinery and preferring their interests to those of the nation. Only through strict compliance with the Government's program can the constant, restless shifting of labor from one war job to another, with the consequent diminution in production and efficiency, be prevented.

Above all, the Government urges every man engaged in war work to stick to his job until the Government recommends that he change. Any man not engaged in war work should put himself at the disposal of the nation by registering with the Public Service Reserve. This is a tremendously important duty! The war worker ranks with the fighter in the trenches. He will help beat the Hun.

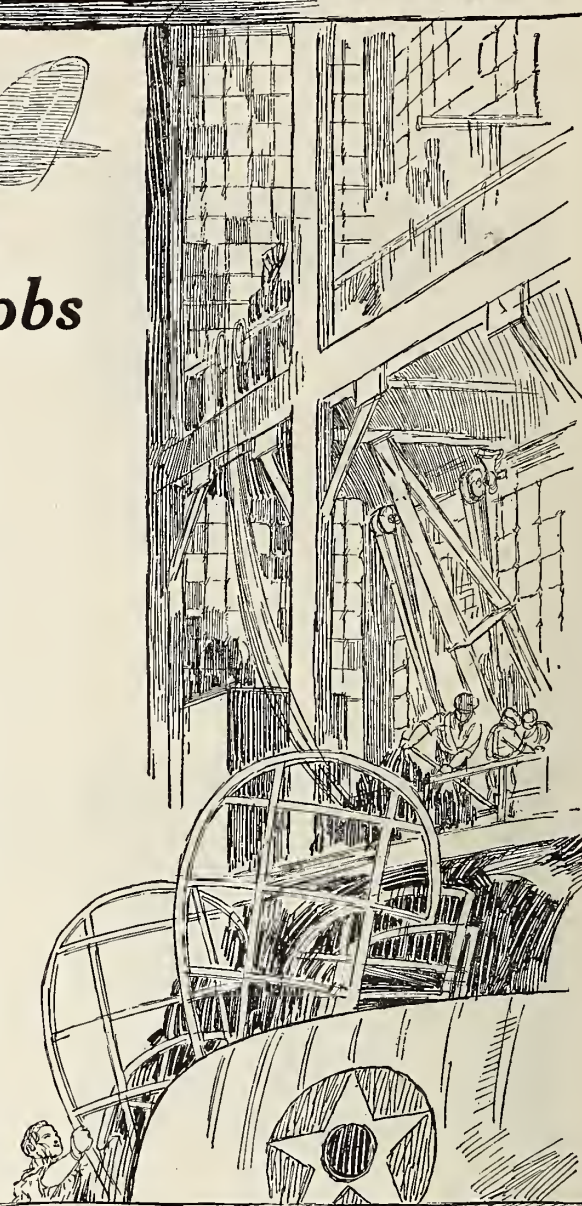

United States Employment Service
U.S. Dept of Labor W.B. Wilson Secy.



Contributed through Division of Advertising.



United States Gov't Comm. on Public Information

This space contributed for the Winning of the War by

THE TALKING MACHINE WORLD, NEW YORK

CHANGES IN EDISON EDITORIAL STAFF

Verdi E. B. Fuller Assumes Directorship of Sales Promotion—Takes Charge Editorially of House Organs Issued by Thos. A. Edison

Verdi E. B. Fuller, general supervisor for Thomas A. Edison, Inc., has recently assumed, in addition to his other duties, the directorship of sales promotion of the New Edison, until



Verdi E. B. Fuller

recently in the hands of Edward C. Boykin. This work includes the managing editorship of the house organs, "Diamond Points" and "Along Broadway," of which Miss Laura Scribner has become associate editor.

Mr. Fuller's work with the company, first as supervisor and then as general supervisor, has made him well known to every Edison jobber in America. Perhaps his most noted achievements have been in connection with the tone tests, which are so notable a feature of Edison publicity. Mr. Fuller is peculiarly qualified for his new duties because of an exhaustive knowledge of all aspects of the Edison business, especially of the selling end. He has a mind fertile in ideas, and a never-failing interest in the ideas of others.

Miss Scribner, who is to work with Mr. Fuller on both publications, graduated from Vassar College this year. She was one of the editors of the college newspaper there, and did some writing for other publications throughout her college course.

VETERAN IN REPAIR DEPARTMENT

J. B. Caldwell, Columbia Co. Repair Man in Portland, Ore., Served in 1898 and Now Has Seven Sons Fighting for the Country

PORTLAND, ORE., August 3.—L. D. Heater, manager of the Columbia Graphophone Co. branch in Portland, is proud of the man at the head of the repair department, Lieut. J. B. Caldwell, who served with distinction in the Spanish-American war and who has seven sons now in the army. Lieut. Caldwell is sixty years old, hale and hearty, a splendid mechanic and a true patriot. He has collected a number of interesting flags which are on display in the windows of the Columbia store. These windows are always surrounded by persons who show a great interest in the display.

In this particular window there is an old silk flag, torn and tattered, carried by a New York regiment during the Civil War. A flag that was raised in Oregon after the assassination of President Lincoln, again after the assassination of President Garfield and a third time at the

death of President McKinley, is another interesting relic. A Confederate flag presented to the brigade of Stonewall Jackson after the Civil War is also of interest.

A naval ensign that was found by Lieut. Caldwell in 1898 after it had been lost from the gun boat Oesta is on display.

Mr. Caldwell has many medals which were presented to him but they are not shown in this window. The sword carried by the lieutenant during the Spanish-American war forms part of the display.

James P. Bradt, general Canadian manager for the Columbia Graphophone Co., was a visitor to New York recently, bringing with him enthusiastic reports regarding the business situation in Canada.

HERZOG PLANT EXPANDING

New Shipping Department and Extension to Plant Constructed to Provide Additional Facilities for Making Sonora Cabinets

SAGINAW, MICH., August 10.—Work has been completed on the new shipping department building of the Herzog Art Furniture Co., erected to house the products of the concern, which is principally engaged in manufacturing Sonora phonograph cabinets. The new building stands opposite the main Herzog plant, on the east side of Michigan avenue. An addition to the Herzog plant is also being constructed at the rear of the present factory, to afford additional facilities for general manufacturing purposes.

The Time for the Holidays is Now!

Last season carload orders for Converto Cabinets that came late had to be turned down. Dealers who ordered a stock *early* got the cabinets and *sold them at a good profit before Christmas*. Orders for Holiday business should be placed *now!*



Patented December 11, 1917

TALKING MACHINE CABINET

This is a clearly demonstrated success. Every single Victor dealer will make money with it; in these days he can't afford not to handle it. It is our sincere advice, first to decide to try it, second to order *early*. Write or wire for prices and particulars.

The C. J. Lundstrom Mfg. Co., Little Falls, N. Y.
Branch Office, Flatiron Bldg., New York City

NOTICE: Lundstrom Converto Cabinets are broadly covered by patents. Infringement will be promptly prosecuted.



Setting Victrola into Cabinet

Sound Doors Open for Playing

The Lundstrom "Converto" Cabinet converts the small "Victrola" into a handsome cabinet type, completely enclosing the machine. It takes the place of a stand and provides a dustproof record rack for 60 records. It re-creates interest in records. It helps you meet low-price competition in cabinet machines and gives you a *good profit*. It costs the customer no more than a good stand!

J. C. ROUSH DISCUSSES TAXATION

Points Out a Certain Unfairness in Methods of Imposition—Industry Should Be Treated Fairly—No Fabulous Profits in Sale of Talkers—Burdens Should Be Distributed Impartially

PITTSBURGH, PA., August 7.—“Do you consider the proposed tax on talking machines a fair one, and do you know of any steps likely to be taken to alter it?” our representative asked Joseph C. Roush, secretary of the National Association of Talking Machine Jobbers, and president of the Standard Talking Machine Co., Pittsburgh.

“Few talking machine distributors or dealers either will have a word of complaint to offer as to the proposed additional taxes on talking machine business, I believe,” Mr. Roush answered. “Every distributor and every dealer I know is ready and willing to meet any reasonable tax, whether imposed at the source of supply, or on the volume of business done, or on the customer. If the Government needs a 10 per cent. tax, or a 20 per cent. tax even, on all commodities in that class in which talking machines are grouped, well and good. We are all ready and willing to charge off every last penny of profits when needed toward winning the war, provided the taxes are impartially imposed.”

“But right there comes the rub,” Mr. Roush continued. “Of course, we all realize that to impose any tax equitably to the very last degree is out of the question. We do have a right to expect, however, that these mammoth tax bills shall at least be drawn with that in view, and if they are not, those on whom too heavy a burden is laid have just cause of complaint.”

“It is reported that the Ways and Means Committee of the House has prepared a tax bill in which talking machines are classed as non-essential to the winning of the war and in which a most unusual method of taxation is developed. It does not contemplate a small tax on all the great number of industries which it considers in this non-essential class, as might be expected, but rather a very heavy tax on just a few commodities, such as talking machines, arguing that the collection of a big tax on a limited number of industries will be much simpler than a small tax on a great number.”

“That such a method is so obviously unfair, so contrary to all ethics of taxation and is such an apparent hardship on those few lines which must bear the burden for all those exempted, it would seem that some of the more

CRYSTAL EDGE MICA DIAPHRAGMS

M
I
C
A

Let us send you samples *today* of our diaphragms and you will readily understand why the best talking machines are equipped with *Crystal Edge Mica* diaphragms exclusively.

We use only the very finest selected mica, the best diaphragm material in the world.

PHONOGRAPH APPLIANCE CO., 109 West Broadway, NEW YORK

clear-thinking of the Ways and Means Committee must insist on a more equitable provision before the tax is presented to Congress in its final form. And yet it appears likely to go through in its present form.

“Nor can members of the trade take any active steps to argue the unwisdom of this discrimination either to the Ways and Means Committee or to Congress without encountering the criticism of being unpatriotic, if not worse.”

“The talking machine trade, therefore, seems perfectly helpless in the hands of the drafters of these great taxes without any opportunity of appeal. If it be determined to tax talking machine sales 20 per cent. and the sales of other similar commodities nothing at all, because it seems easier to collect a given amount from a few taxpayers than from many, then I can see no effective way of defense from this injustice. In this defenselessness, however, should lie the safety of the talking machine interests, because it puts upon the drafters of the tax bill the moral responsibility of defending the trade from discrimination, of seeing to it that it receives an absolutely square deal.

“Whatever effort is made by the trade I would urge be directed toward securing a fair, impartial tax on all industries not considered essential to the winning of the war, that none be taxed out of business and, incidentally, lost as a future source of revenue; that none be so favored with no taxation that they be able to expand and pre-empt the fields of those whose too heavy tax burdens have forced them to retrench.

“One impression which seems generally current regarding our trade, and which should be corrected at every opportunity, is that there are fabulous profits made in the sales of talking machines, and that to impose a good stiff tax on

talking machines is in reality taking a rap at a crowd of profiteers. Such is farthest from the facts. Probably no other great industry has advanced its prices less in proportion to rising costs of manufacture, transportation and sales than the talking machine industry. Probably no other industry has suffered more than ours in the scarcity of supplies, transportation difficulties and through shortage of labor, for in none of these things could or would we in any sense compete with industries engaged in war work. In fact, the talking machine trade is making less in gross sales and a smaller net profit on those sales to-day and has made less during the war period than before war was declared.

“No one engaged in the talking machine trade has anything to fear in the way of taxation, provided these facts are considered and the burdens are distributed impartially. We are all in this war to win—to win at all costs. Our taxes, our contributions, our very utmost efforts are available whenever and wherever they are needed. But I am urging most emphatically that members of the trade do not let this nor what I have said regarding our helplessness deter them from opposing most strenuously whenever they can create opportunity any method of taxation that will exempt any group without just cause, that will lay too great a burden on any group, or that will endanger the confidence of the country's business men at this critical time, in those who are framing these stupendous tax bills.”

ANOTHER “NATIONAL” NOVELTY

The Watch Dog Savings Bank Will Appeal to Talking Machine Merchants

BOSTON, MASS., August 9.—The announcement of an entirely new and original novelty was made by the National Co., of 273-279 Congress



The Watch Dog Savings Bank

street, this city. A few years ago the National Co. brought out the “Wireless Pup,” which met with instantaneous success and still continues in strong popularity. The new novelty which will be placed on the market during August is called the “Watch Dog Savings Bank.” It is expected that this will prove even more of an attraction than the “Wireless Pup,” as it combines a bank with the novelty of a dog that obeys a sound. A number of talking machine dealers found the “Wireless Pup” a popular side line, and it is expected that the “Watch Dog Savings Bank” will prove equally so.

The Kaiser has not invested in War Savings Stamps. Have you?

We are large manufacturers of

Cabinets—Cabinets—Cabinets

For dealers, wholesalers and jobbers or those who desire to sell their own brand, style and make of talking machines. Let us figure on what you desire. We are not too busy to build your

Cabinets

Forty-seven years of experience speaks volumes for quality, style and finish.

Chas. Passow & Sons
2121 to 2141 ALLPORT STREET CHICAGO, ILL.

Have you seen the new Columbia Non-Set Stop? Absolutely fool-proof; requires no attention whatever; found on no other instruments made except the new model Grafonolas.

**Columbia Graphophone Co.
NEW YORK**



RECORD MAKERS BOOKING DATES

Popular Record Makers Now Arranging for Concerts for Next Fall and Winter—Organization Has Proven a Very Strong Attraction

The Popular Record Makers who, during the past couple of seasons, have filled a number of successful engagements in numerous cities in the East in co-operation with various talking machine wholesalers and retailers, as well as organizations of talking machine men, are now booking concerts for the coming fall and winter under the management of M. M. McClaskey.

The appearance of the record makers in person appears to have a peculiar fascination for owners of talking machines and phonographs, who grasp eagerly the opportunity of hearing in person those whose voices they have become familiar with through hearing them for years in talking machine records of various makes, for the recordings of the Popular Record Makers are not confined to any particular make of record. Henry Burr, Collins and Harlan, Billy Murray, they have all been familiar for many years in homes throughout the land, a fact that is made quite evident through the enthusiastic reception accorded them in concert.

Those who appear under the heading "Popular Record Makers" include: Henry Burr, Byron G. Harlan, Billy Murray and Albert Campbell, tenors; Arthur Collins, baritone; John H. Meyer, basso; Fred Van Eps, banjoist, and Theodore Morse, pianist and accompanist. The members of this group of artists make up the famous Sterling Trio and Peerless Quartet.

The newspapers in the cities in which the Popular Record Makers have appeared have been most enthusiastic in their notices regarding the concert, the enthusiasm being also evident on the part of the audience and the talking machine interests who have arranged for the concerts.

During the past few months the Popular Record Makers have displayed their patriotism frequently by entertaining the soldiers in various camps and at various benefits arranged for the fighting men. On August 8, for instance, Henry Burr, Albert Campbell, John H. Meyer, Billy Murray, Frank Croxton and Theodore Morse entertained an audience of nearly 4,000 soldiers in the Y. M. C. A. Building at Camp Merritt, N. J., and declared that their efforts were more than repaid by the appreciation evidenced by the soldiers.

"COLUMBIA RECORD" FOR AUGUST

The "Columbia Record" for August features a new series of cut-outs that has been prepared for Columbia dealers by the dealer service department, together with other interesting dealer helps that are now ready for the use of Columbia representatives. This issue also calls attention to the completion of a new series of record delivery bags, and there are the usual number of timely suggestions that can be utilized to advantage by Columbia dealers.

ASSOCIATION MEETING POSTPONED

Portland, Ore., Dealers Eliminate July Session —Geo. W. Hopkins Entertained

PORTLAND, ORE., August 3.—So many of the talking machine dealers were off on summer vacations, East on buying trips or otherwise engaged that the Portland Talking Machine Dealers' Association meeting for July was postponed. L. D. Heater, manager of the local branch of the Columbia Co., who was vice-president of the association, has resigned from the association. Mr. Heater says that as he is manager of a wholesale house he considers it better to withdraw from the association which is composed of retail dealers.

Despite the fact that there was no monthly meeting of the association, dealers of many firms got together in July, when L. D. Heater gave a dinner at the Imperial Hotel in honor of George W. Hopkins, of New York City, general sales manager of the Columbia Co. To this dinner all dealers and sales people handling the Columbia line were invited.

Mr. Hopkins gave an informal but very instructive talk. A new Columbia 115, with the new automatic stop, was on exhibition and furnished music for the occasion and demonstrated the efficiency of the non-set stop.

Mr. Hopkins declared that music is as essential to the well-being of soldiers as cigarettes and he told of the thousands of Columbias now with the American soldiers in France. Officers who come back, he said, relate how the boys play their talking machines at that highly nervous time just before going over the top.

In conversation with the correspondent of The Talking Machine World Mr. Hopkins said that on this trip he had found trade exceptionally good with business increasing rapidly. He had visited Los Angeles, San Francisco and Portland and returned to New York by way of Seattle, Spokane, Salt Lake and Denver, where he will look into business conditions. He spoke in a highly complimentary way on the way in which he finds business conducted by the talking machine dealers of Portland and declared that the unusually fine window displays which he found in the local music stores are the best he has seen in any city. He expressed himself as greatly pleased at the increase in the Columbia business in Portland, which he said was 100 per cent. in the last year. Mr. Hopkins visited the cantonment at Vancouver Barracks and took in the famous Columbia Highway trip.

VICSONIA PRICES TO ADVANCE

The Vicsonia Mfg. Co., Inc., New York, manufacturers of the Vicsonia reproducer for playing Edison records on other types of machines, are urging their dealers to place orders immediately for fall deliveries in order to take advantage of existing prices. The company announces that, owing to the increased cost of all materials, the prices of the various styles of Vicsonia reproducers will be advanced on September 1.

SUGGESTS A FUND FOR FIGHTERS

Urge That Members of the Trade Contribute to a Fund to Provide Little Luxuries for Trade Members Now in Country's Service

It has been strongly suggested that there be some organized effort made in the local trade to show its appreciation for the sacrifices made by those of its members who have entered either the military or naval service of the country. It has been urged that steps be taken to raise a fund in the trade to provide for the purchase of kits or other tokens for the men in service, or to provide some entertainment for them while they are in the city on leave. It is believed that a contribution of from \$2 to \$5 from jobbers and dealers, together with small contributions from salesmen and others, should provide a fund sufficient to take care of this matter, and thereby extend various courtesies to the fighting men at a small individual expense.

It is felt that the fund thus created should be placed in the hands of either a committee or individual, who could attend to its disbursement along the desired lines, such as purchasing toilet articles, chocolates, cigarettes, etc., and perhaps dinners at intervals for the fighting men who are in the city.

The Larkatone Music Co., recently incorporated in St. Louis, are conducting a retail talking machine business at 3749 South Jefferson avenue. They intend later to add on a line of music rolls.



DEALERS

Tell your customers how their phonographs may teach them a language by the

CORTINA Phone-Method

Increase your record sales by selling them Cortina language record sets. A timely set for which there has been a great demand is the Cortina Military French-English course.

Send for full information. Advertising matter and poster-hangers free.

Cortina Academy of Languages
12 East 46th Street :: New York

TALKING MACHINE MEN HOLD THEIR ANNUAL OUTING

Despite Intensely Hot Weather Goodly Number Make the Trip to Bear Mountain on August 7 and Enjoy Excellent Dinner and a Greatly Curtailed Baseball Game

The much-heralded annual outing of the Talking Machine Men, Inc., the organization composed of talking machine dealers of New York, New Jersey and Connecticut, was held on Wednesday, August 7, at Bear Mountain-on-the-Hudson, the same place where the organization held its very successful outing about this time last year.

Although the day was the hottest that has been experienced in this section in the history of the Weather Bureau, according to reports, with the thermometer keeping well above the 100 mark, a large number of talking machine dealers and wholesalers, with their friends and women folk, braved the city's heat to report at

not ideal and that the looks of satisfaction of those seated were just camouflage.

Whether it was the inclination to take part



Getting Ready for the Game

in some sport or an effort to retrieve the expenses of the day is not known, but a little gathering reserved space in one of the staterooms and took part in the great American game, and it was announced that B. R. Forster might, with the same success on the way back, have a satisfactory day.

Arriving at Bear Mountain just before noon the party took the new jitneys up the hill and ensconced themselves in the dining hall awaiting the dinner announcement. When all were seated a chicken dinner was served and seemed to be

served to satisfy the players with the sport and give the "Davinites" three runs, which they were as proud of as if they had won a nine-inning game. At that it was a lively contest while it lasted and Lipman Kay, who was drafted by the teams as the umpire, seemed quite pleased when the game was not prolonged. The team captained by J. Davin was composed of Owens, Cassidy, Abelowitz, Bradley, Rollins, Roth, Davin, Hutchins and Schoonmacher, and the opposing team consisted of Graffen, Strauss, C. Abelowitz, Thompson, Forster, Kurtz and a number of others who refused to consent to face the opposing pitcher.

While a considerable number in the party re-



Ziegler and Bolton



B. R. Forster

turned to the city in the early afternoon the majority waited until the cool of the evening, and returned on the boat, which left at six-thirty.

After the dinner each of the ladies who attended was presented with a pound box of chocolates.

R. F. Bolton, sales manager of the foreign record division of the Columbia Graphophone Co., made the trip to Bear Mountain by automobile accompanied by his son.

James Davin seemed to be the life of the party, insisting on a ball game and succeeding in getting the players together, showing that a smile will always win under the most trying conditions.

The benches around the outer edge of the baseball diamond were at a premium. No, they did not sit on them, they lay beneath them, as that was the only place where there was shade to be found.

Owing to the intense heat it was decided to call off the various other athletic events scheduled for the afternoon, including the races of various sorts, and therefore the sprinters among the fat men will probably have to wait until next year before they will be able to test their respective abilities as runners in competition. As one dealer remarked, the only thing that had a right to run on a day like that was perspiration.

Full credit is given to the arrangements committee for the smooth manner in which the entire affair worked out according to schedule, even though under a heavy handicap. The boat trip, the dinner and the other details were handled most capably. The committee in charge of the outing consisted of Sol. Lazarus, E. Leins, J. E. Hunt, J. T. Coughlin, Saul Birns, H. Mielke and J. J. Davin.

HAS JOINED THE COLORS

Richard Augur, of the firm of Augur, Swyers & Machold, who has made a specialty of Christmas record boxes, has joined the colors and is now in training at Fort Hancock.

OPENS NEW STORE

W. F. Peker has opened a new store in Hampton, Ia., for the sale of talking machines, records and other musical instruments.



Messrs. Leins, Kay and Galuchie

the dock at the appointed hour for the sail up the river. Incidentally, be it said, the hardy ones who attended the outing had a thoroughly good time, and as a social affair it was a distinct success.

The trip up the Hudson was made on the palatial steamer "Washington Irving," which left the dock at the foot of West Forty-second street promptly at 9 a. m. On the way up the time was spent chiefly in locating the coolest spot on the boat, which proved an elusive pursuit. Although on one of the upper decks some of the members congregated in the shade, much to the discomfiture of those who were not, it was realized later that the spot was

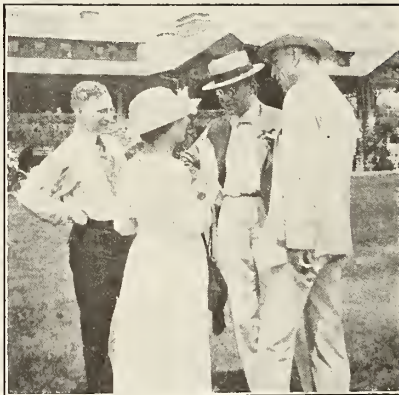

Lambert Friedl "Joshing"

the means of giving the more optimistic ones much ambition, as immediately after dinner a ball game was announced as the next number.

James Davin headed a Victor team and O. P. Graffen captained a Columbia-Brunswick team and an inning and a half, together with the heat,



Strouse and Condon



Record Cabinets

Made by Nanes Art Furniture Co. New York City

Record Envelopes



PIANO CREAM

is wonderful for restoring the lustre to Talking Machines

Thirty desirable records. You may not have all of these selections. We will gladly play any record for you.

INSTRUMENTAL		VOCAL Continued	
1001	March (Piano)	1015	Swanee Song (Soprano)
1002	March (Piano)	1016	Swanee Song (Soprano)
1003	March (Piano)	1017	Swanee Song (Soprano)
1004	March (Piano)	1018	Swanee Song (Soprano)
1005	March (Piano)	1019	Swanee Song (Soprano)
1006	March (Piano)	1020	Swanee Song (Soprano)
1007	March (Piano)	1021	Swanee Song (Soprano)
1008	March (Piano)	1022	Swanee Song (Soprano)
1009	March (Piano)	1023	Swanee Song (Soprano)
1010	March (Piano)	1024	Swanee Song (Soprano)
1011	March (Piano)	1025	Swanee Song (Soprano)
1012	March (Piano)	1026	Swanee Song (Soprano)
1013	March (Piano)	1027	Swanee Song (Soprano)
1014	March (Piano)	1028	Swanee Song (Soprano)
1015	March (Piano)	1029	Swanee Song (Soprano)
1016	March (Piano)	1030	Swanee Song (Soprano)
1017	March (Piano)	1031	Swanee Song (Soprano)
1018	March (Piano)	1032	Swanee Song (Soprano)
1019	March (Piano)	1033	Swanee Song (Soprano)
1020	March (Piano)	1034	Swanee Song (Soprano)
1021	March (Piano)	1035	Swanee Song (Soprano)
1022	March (Piano)	1036	Swanee Song (Soprano)
1023	March (Piano)	1037	Swanee Song (Soprano)
1024	March (Piano)	1038	Swanee Song (Soprano)
1025	March (Piano)	1039	Swanee Song (Soprano)
1026	March (Piano)	1040	Swanee Song (Soprano)
1027	March (Piano)	1041	Swanee Song (Soprano)
1028	March (Piano)	1042	Swanee Song (Soprano)
1029	March (Piano)	1043	Swanee Song (Soprano)
1030	March (Piano)	1044	Swanee Song (Soprano)
1031	March (Piano)	1045	Swanee Song (Soprano)
1032	March (Piano)	1046	Swanee Song (Soprano)
1033	March (Piano)	1047	Swanee Song (Soprano)
1034	March (Piano)	1048	Swanee Song (Soprano)
1035	March (Piano)	1049	Swanee Song (Soprano)
1036	March (Piano)	1050	Swanee Song (Soprano)
1037	March (Piano)	1051	Swanee Song (Soprano)
1038	March (Piano)	1052	Swanee Song (Soprano)
1039	March (Piano)	1053	Swanee Song (Soprano)
1040	March (Piano)	1054	Swanee Song (Soprano)
1041	March (Piano)	1055	Swanee Song (Soprano)
1042	March (Piano)	1056	Swanee Song (Soprano)
1043	March (Piano)	1057	Swanee Song (Soprano)
1044	March (Piano)	1058	Swanee Song (Soprano)
1045	March (Piano)	1059	Swanee Song (Soprano)
1046	March (Piano)	1060	Swanee Song (Soprano)
1047	March (Piano)	1061	Swanee Song (Soprano)
1048	March (Piano)	1062	Swanee Song (Soprano)
1049	March (Piano)	1063	Swanee Song (Soprano)
1050	March (Piano)	1064	Swanee Song (Soprano)
1051	March (Piano)	1065	Swanee Song (Soprano)
1052	March (Piano)	1066	Swanee Song (Soprano)
1053	March (Piano)	1067	Swanee Song (Soprano)
1054	March (Piano)	1068	Swanee Song (Soprano)
1055	March (Piano)	1069	Swanee Song (Soprano)
1056	March (Piano)	1070	Swanee Song (Soprano)
1057	March (Piano)	1071	Swanee Song (Soprano)
1058	March (Piano)	1072	Swanee Song (Soprano)
1059	March (Piano)	1073	Swanee Song (Soprano)
1060	March (Piano)	1074	Swanee Song (Soprano)
1061	March (Piano)	1075	Swanee Song (Soprano)
1062	March (Piano)	1076	Swanee Song (Soprano)
1063	March (Piano)	1077	Swanee Song (Soprano)
1064	March (Piano)	1078	Swanee Song (Soprano)
1065	March (Piano)	1079	Swanee Song (Soprano)
1066	March (Piano)	1080	Swanee Song (Soprano)
1067	March (Piano)	1081	Swanee Song (Soprano)
1068	March (Piano)	1082	Swanee Song (Soprano)
1069	March (Piano)	1083	Swanee Song (Soprano)
1070	March (Piano)	1084	Swanee Song (Soprano)
1071	March (Piano)	1085	Swanee Song (Soprano)
1072	March (Piano)	1086	Swanee Song (Soprano)
1073	March (Piano)	1087	Swanee Song (Soprano)
1074	March (Piano)	1088	Swanee Song (Soprano)
1075	March (Piano)	1089	Swanee Song (Soprano)
1076	March (Piano)	1090	Swanee Song (Soprano)
1077	March (Piano)	1091	Swanee Song (Soprano)
1078	March (Piano)	1092	Swanee Song (Soprano)
1079	March (Piano)	1093	Swanee Song (Soprano)
1080	March (Piano)	1094	Swanee Song (Soprano)
1081	March (Piano)	1095	Swanee Song (Soprano)
1082	March (Piano)	1096	Swanee Song (Soprano)
1083	March (Piano)	1097	Swanee Song (Soprano)
1084	March (Piano)	1098	Swanee Song (Soprano)
1085	March (Piano)	1099	Swanee Song (Soprano)
1086	March (Piano)	1100	Swanee Song (Soprano)
1087	March (Piano)	1101	Swanee Song (Soprano)
1088	March (Piano)	1102	Swanee Song (Soprano)
1089	March (Piano)	1103	Swanee Song (Soprano)
1090	March (Piano)	1104	Swanee Song (Soprano)
1091	March (Piano)	1105	Swanee Song (Soprano)
1092	March (Piano)	1106	Swanee Song (Soprano)
1093	March (Piano)	1107	Swanee Song (Soprano)
1094	March (Piano)	1108	Swanee Song (Soprano)
1095	March (Piano)	1109	Swanee Song (Soprano)
1096	March (Piano)	1110	Swanee Song (Soprano)
1097	March (Piano)	1111	Swanee Song (Soprano)
1098	March (Piano)	1112	Swanee Song (Soprano)
1099	March (Piano)	1113	Swanee Song (Soprano)
1100	March (Piano)	1114	Swanee Song (Soprano)
1101	March (Piano)	1115	Swanee Song (Soprano)
1102	March (Piano)	1116	Swanee Song (Soprano)
1103	March (Piano)	1117	Swanee Song (Soprano)
1104	March (Piano)	1118	Swanee Song (Soprano)
1105	March (Piano)	1119	Swanee Song (Soprano)
1106	March (Piano)	1120	Swanee Song (Soprano)
1107	March (Piano)	1121	Swanee Song (Soprano)
1108	March (Piano)	1122	Swanee Song (Soprano)
1109	March (Piano)	1123	Swanee Song (Soprano)
1110	March (Piano)	1124	Swanee Song (Soprano)
1111	March (Piano)	1125	Swanee Song (Soprano)
1112	March (Piano)	1126	Swanee Song (Soprano)
1113	March (Piano)	1127	Swanee Song (Soprano)
1114	March (Piano)	1128	Swanee Song (Soprano)
1115	March (Piano)	1129	Swanee Song (Soprano)
1116	March (Piano)	1130	Swanee Song (Soprano)
1117	March (Piano)	1131	Swanee Song (Soprano)
1118	March (Piano)	1132	Swanee Song (Soprano)
1119	March (Piano)	1133	Swanee Song (Soprano)
1120	March (Piano)	1134	Swanee Song (Soprano)
1121	March (Piano)	1135	Swanee Song (Soprano)
1122	March (Piano)	1136	Swanee Song (Soprano)
1123	March (Piano)	1137	Swanee Song (Soprano)
1124	March (Piano)	1138	Swanee Song (Soprano)
1125	March (Piano)	1139	Swanee Song (Soprano)
1126	March (Piano)	1140	Swanee Song (Soprano)
1127	March (Piano)	1141	Swanee Song (Soprano)
1128	March (Piano)	1142	Swanee Song (Soprano)
1129	March (Piano)	1143	Swanee Song (Soprano)
1130	March (Piano)	1144	Swanee Song (Soprano)
1131	March (Piano)	1145	Swanee Song (Soprano)
1132	March (Piano)	1146	Swanee Song (Soprano)
1133	March (Piano)	1147	Swanee Song (Soprano)
1134	March (Piano)	1148	Swanee Song (Soprano)
1135	March (Piano)	1149	Swanee Song (Soprano)
1136	March (Piano)	1150	Swanee Song (Soprano)
1137	March (Piano)	1151	Swanee Song (Soprano)
1138	March (Piano)	1152	Swanee Song (Soprano)
1139	March (Piano)	1153	Swanee Song (Soprano)
1140	March (Piano)	1154	Swanee Song (Soprano)
1141	March (Piano)	1155	Swanee Song (Soprano)
1142	March (Piano)	1156	Swanee Song (Soprano)
1143	March (Piano)	1157	Swanee Song (Soprano)
1144	March (Piano)	1158	Swanee Song (Soprano)
1145	March (Piano)	1159	Swanee Song (Soprano)
1146	March (Piano)	1160	Swanee Song (Soprano)
1147	March (Piano)	1161	Swanee Song (Soprano)
1148	March (Piano)	1162	Swanee Song (Soprano)
1149	March (Piano)	1163	Swanee Song (Soprano)
1150	March (Piano)	1164	Swanee Song (Soprano)
1151	March (Piano)	1165	Swanee Song (Soprano)
1152	March (Piano)	1166	Swanee Song (Soprano)
1153	March (Piano)	1167	Swanee Song (Soprano)
1154	March (Piano)	1168	Swanee Song (Soprano)
1155	March (Piano)	1169	Swanee Song (Soprano)
1156	March (Piano)	1170	Swanee Song (Soprano)
1157	March (Piano)	1171	Swanee Song (Soprano)
1158	March (Piano)	1172	Swanee Song (Soprano)
1159	March (Piano)	1173	Swanee Song (Soprano)
1160	March (Piano)	1174	Swanee Song (Soprano)
1161	March (Piano)	1175	Swanee Song (Soprano)
1162	March (Piano)	1176	Swanee Song (Soprano)
1163	March (Piano)	1177	Swanee Song (Soprano)
1164	March (Piano)	1178	Swanee Song (Soprano)
1165	March (Piano)	1179	Swanee Song (Soprano)
1166	March (Piano)	1180	Swanee Song (Soprano)
1167	March (Piano)	1181	Swanee Song (Soprano)
1168	March (Piano)	1182	Swanee Song (Soprano)
1169	March (Piano)	1183	Swanee Song (Soprano)
1170	March (Piano)	1184	Swanee Song (Soprano)
1171	March (Piano)	1185	Swanee Song (Soprano)
1172	March (Piano)	1186	Swanee Song (Soprano)
1173	March (Piano)	1187	Swanee Song (Soprano)
1174	March (Piano)	1188	Swanee Song (Soprano)
1175	March (Piano)	1189	Swanee Song (Soprano)
1176	March (Piano)	1190	Swanee Song (Soprano)
1177	March (Piano)	1191	Swanee Song (Soprano)
1178	March (Piano)	1192	Swanee Song (Soprano)
1179	March (Piano)	1193	Swanee Song (Soprano)
1180	March (Piano)	1194	Swanee Song (Soprano)
1181	March (Piano)	1195	Swanee Song (Soprano)
1182	March (Piano)	1196	Swanee Song (Soprano)
1183	March (Piano)	1197	Swanee Song (Soprano)
1184	March (Piano)	1198	Swanee Song (Soprano)
1185	March (Piano)	1199	Swanee Song (Soprano)
1186	March (Piano)	1200	Swanee Song (Soprano)

CLEMENT BEECROFT 309 W. Susquehanna Ave. PHILADEL

DOEHLER DIE-CASTINGS

for tone arms, sound boxes and talking machine attachments are STANDARD throughout the industry.

Of the many instruments produced to-day from the most prominent makes down, the greater number, by far, are equipped with Doehler die-cast tone arm and sound box.

The enormous output of our three large plants permits of advantages to the users of die-castings, as regards prices and deliveries, not otherwise possible.

DOEHLER DIE-CASTING CO.

MAIN OFFICE AND EASTERN PLANT
 WESTERN PLANT TOLEDO, OHIO. BROOKLYN, N.Y. NEW JERSEY PLANT NEWARK, N.J.

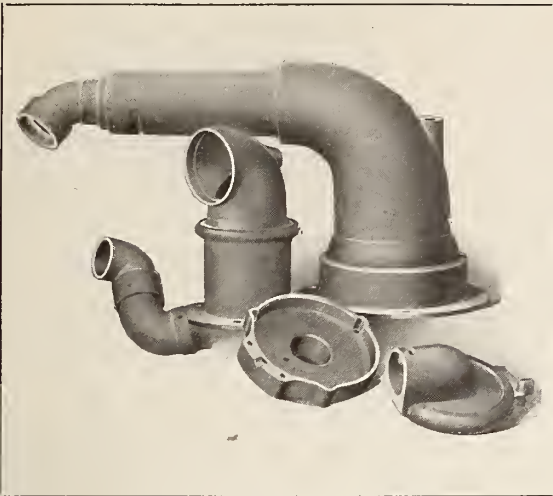

NEW COLUMBIA HOME IN BUFFALO

Beautiful New Quarters Now Completed and Occupied by Columbia Company's Buffalo Branch of Which O. M. Kiess Is Manager

BUFFALO, N. Y., August 6.—The new quarters of the Western New York distributing branch of



Manager O. M. Kiess' Private Office

the Columbia Graphophone Co. in this city have been completed and occupied since May. The offices and warehouse of the local branch now occupy the second and third floors of a modern, fireproof building at 733-5-7 Main street, most admirably adapted to the company's business. Ten thousand square feet of floor space provide ample facilities for systematic handling



Partial View of General Offices

and distribution of stock to Western New York dealers.

The entire third floor of the building is given over to Grafonola stock, while the second floor is advantageously divided, accommodating the offices, record stock room, dealers' sample rooms, repair shop and shipping department.

Plenty of sunlight and fresh air are noticeable characteristics, making the new quarters healthful as well as pleasant, and contributing greatly to the happiness and satisfaction of employees. This is as it should be; for, as Manager O. M. Kiess aptly puts it, "We all live here." Neither pains nor money has been spared in fitting up the Columbia's new home, and the result is apparent in every department,

from the manager's office to the elevator.

The offices, partially shown in the accompanying photographs, are light, airy and commodious. A completely equipped school for the training of Dicta-typists is a feature of the Dictaphone department.

The record stockroom is a model for system and efficiency. The arrangement and consecutive numbering of the record racks permit the filling of orders with a minimum of time and labor. The record department's motto is "Every order will be shipped to-day."

The arrangement and facilities of the ship-



Section of Model Record Stockroom

ping department enable it to back up the record department in its service motto. Here

again, as also in the repair department, plenty of light and air make working conditions ideal.

A three-ton elevator, large enough to accom-



School for Training of Dicta-typists

modate a truck load of Grafonolas and the truck as well, is a great time and labor saver, and solves many an otherwise serious stock handling problem. An attractive and comfortable room for the use of dealers and for the display of Grafonola samples and accessories is convenient to the offices.

The plans for the new quarters were drawn by Manager Kiess, and the construction work carried out under his direct supervision; and he takes pardonable pride in the fact that he has built for the Columbia line a worthy home.

THE VEECO WAY

Takes all the Uncertainty out of the ELECTRIC OPERATION OF TALKING MACHINES

The improved VEECO electric motor is designed primarily and exclusively for Talking Machines. It is smooth and noiseless in action and practically fool-proof. Standard models run on any voltage from 100-125, A. C. or D. C., without adjustment. Other models for any voltage from 6-250. Furnished mounted on 12 or 12½ inch mahogany board ready to install, or without board, all ready to mount on such board as used by the manufacturer.

With the VITRALOID turntable, supplied with the motor, it makes a complete motor unit for high class machines.

Send for a sample NOW and place your order at once for early fall delivery.

THE VEECO COMPANY

248 Boylston St.

Boston, Mass.

THE ORIGINAL PRODUCERS OF A COMPLETE ELECTRIC DRIVE FOR TALKING MACHINE MANUFACTURERS' USE

SONORA CO. WINS COURT VICTORY

New York Supreme Court Grants Injunction Against Infringement of Company's Trade-Mark—President Brightson's Comments

As noted on another page of this issue of The World Justice Ottinger, of the Supreme Court of the State of New York, handed down an important decision last month granting a preliminary injunction to the Sonora Phonograph Sales Co., Inc., that restrains Chas. de Stefano and Benjamin Katcher from infringing the Sonora's trade-mark.

On July 24 Justice Ottinger signed an order enjoining the defendants preliminarily from directly or indirectly infringing the plaintiff's trade name or trade-mark "Sonora" and the plaintiff's rights therein, and further preliminarily restraining the defendants and each of them, and all persons, firms or corporations acting for or on behalf of them from directly or indirectly transacting any business under the name "Lonora," as a trade name, trade-mark or otherwise, or any phonograph or talking machine, and from using in any advertisement, announcement, placard, correspondence or in any other way or manner whatsoever the word "Lonora," or any other word resembling the word "Sonora" or "Lonora" in connection with phonographs or talking machines.

George E. Brightson, president of the Sonora Phonograph Sales Co., in commenting upon this important decision, remarked as follows:

"The result is very gratifying. This is but one of a series of similar actions which we shall institute for the purpose of protecting the trade name and trade-mark 'Sonora.' We have spent hundreds of thousands of dollars in advertising 'Sonora' throughout the United States, and we cannot stand idly by and submit to the usurpation of our name and our good will. We have endeavored, by a consistent advertising policy, to impress the public with the high quality of the Sonora Co.'s products. We cannot permit that a reputation, founded upon the efforts of years, and at tremendous costs, be jeopardized by such unfair trade practices. Furthermore, as Judge Ottinger said, 'the purpose of the defendants is to deceive and defraud the public into the belief that the articles are those manufactured by the plaintiff (the Sonora).' Irrespective of such unfair trade practices, the Sonora Co. will see to it, as far as its own products are concerned, that the public will be freed from the unconscionable

acts of those who endeavor to take advantage of the trade name and reputation that the Sonora has acquired."

J. Schechter, of the firm of Schechter & Lotsch, attorneys for the Sonora Phonograph Sales Co., referring to the court's decision said:

"The decision can leave no doubt in any person's mind that unfair trade practices, such as the defendants employed, will not be tolerated by our courts. The Sonora Co. will, in all cases coming to its notice, pursue the same vigorous policy of prosecuting those guilty of such unfair business methods. There has been entirely too much forbearance upon the part of the Sonora, and other concerns whose trade names, established through years of effort and cost, have thus been invaded. Regardless of the trouble and expense, infringers of trade names, trade-marks, etc., should be vigorously prosecuted, not only for the protection of the purchasing public, but in the interests and for the welfare of sound business principles."

SOME INTERESTING LITERATURE

Recently Sent Out to Its Dealers by the New York Talking Machine Co.

The New York Talking Machine Co., Victor wholesalers, recently sent out to its dealers an interesting batch of literature, the most important feature of which was a four-page folder entitled "Essentials, All of Them," that listed the following essentials: "Men," "Money," "Machinery," "Munitions," "Merchant Marine" and "Music." There was a further notation on the front page that "The Government recognizes music as one of the great forces that will help win the war," and the timely comment that "the Victrola is the most compact, inexpensive portable form of music obtainable for the home, ship or field."

The inside pages of this interesting folder called attention to the tremendous importance of music at the present time, and emphasized the fact that notwithstanding the sacrifices made by Victor dealers and their contributions to the many war funds, etc., they can still give more by offering their patrons up-to-date Victor record lists that will provide "Food for the heart and soul, and happiness for those who need it."

The National Phonograph Co., Loveland, Cal., has arranged to begin the manufacture of talking machines in that city, having taken over the very complete plant of W. C. Green & Son, cabinet makers.

Hillman & Son Phonograph Co.

Wheeling, West Virginia

Exclusive Wholesale Distributors for West Virginia and Virginia

THE INSTRUMENT OF QUALITY
Sonora
CLEAR AS A BELL

All models shipped promptly from our large warehouse, 1126 Main Street

Diamond Needles and Sapphire Needles for Sale

ENJOYING A BRISK BUSINESS

The Celina Furniture Co., of Celina, O., report generally brisk business in all their lines. As their name implies, they are a long-established furniture house and have built into the cabinet work which they produce the combined results of their many years of experience in that field. Besides the Harponola, which they produce, they have made a specialty of producing

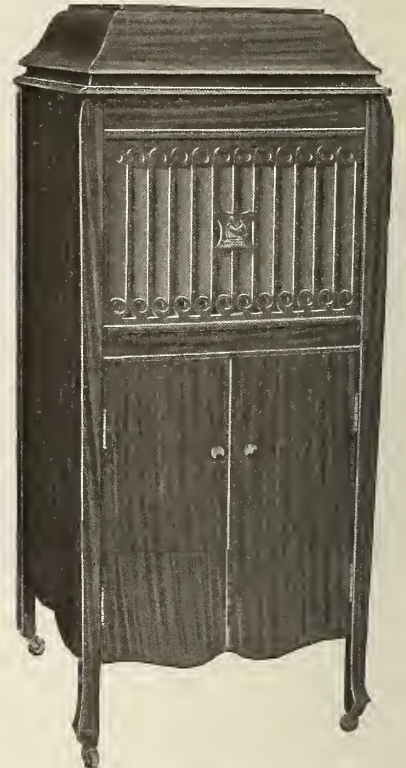

The Harponola

cabinets for other manufacturers, unequipped. Another phase of their business, which they report is very active, is the production of fully equipped cabinets for jobbers, furnished under the jobber's name. Many have already placed their fall orders and the Celina Co. expect a very busy season.

TWO NEW COLUMBIA TRAVELERS

Lambert Friedl, manager of the local wholesale branch of the Columbia Graphophone Co., 55 Warren street, announced this week the appointment of C. H. Baker and A. A. Fair as members of the company's traveling staff. Mr. Baker will visit Columbia dealers in the southern part of New York State, and Mr. Fair will call upon the trade in the northern part of the State. Columbia sales in this territory are increasing rapidly and these new travelers will endeavor to co-operate with Columbia dealers in developing still further the business in that territory.

SHELTON ELECTRIC PHONOGRAPH MOTOR

We have increased our factory facilities to handle the demand for the Shelton Electric Motor, and are now ready to make prompt deliveries.

Write for our Special Agency Proposition

SHELTON ELECTRIC CO.
30 East 42nd Street, NEW YORK

An Actual Test of THE VICSONIA

in the dealer's own store is the best argument for this wonderful Reproducer for playing Edison Records on other makes of machines.

Scientifically constructed and handsomely finished in Nickel and Gold—equipped with Floating Jewel.

Place your orders now, and at present prices, to insure prompt deliveries. Prices advance Sept. 1st

In featuring the VICSONIA you are doing your customers a favor as well as making a substantial and quick profit.

Vicsonia Manufacturing Company, Inc.
313 East 134th Street (Bronx) NEW YORK, N. Y.

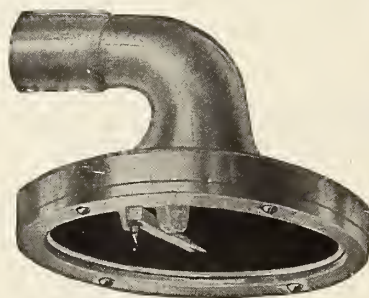

REPAIRS

TALKING MACHINE TROUBLES AND
HOW TO REMEDY THEM

Conducted by Andrew H. Dodin

[This department of The Talking Machine World is designed for the service of all classes of our readers, including those who make, and those who sell, talking machines. Andrew H. Dodin, who conducts this department, has a wide and enviable reputation as a repairer of talking machines and conducts an exclusive talking machine repair shop at 176 Sixth avenue, New York. Tell him your troubles through The World and he will help you if possible. The service is free.—Editor.]

"THE STEPHENSON MOTOR"

"The creation of a better motor" was the aim of the designers of the Stephenson motor. It is my opinion that they have succeeded in accomplishing their aim, and I think that a description of the construction of this well-made, silent-running motor will be of interest to all in the trade.

The spring drums, the governor shaft and the turntable shaft, although of larger dimensions than ordinary, are placed in such relation to each other as to still make the motor a compact unit, with no overhanging parts. This compactness is of great advantage to the phonograph manufacturer, as it permits the use of larger tone chambers.

The frame of the motor, made of cast iron,

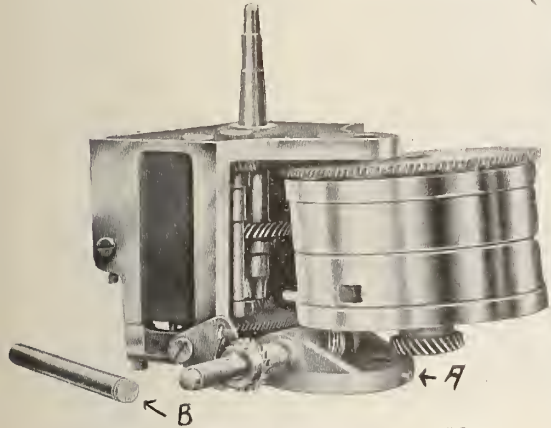

Replacing Spring in Stephenson Motor completely encases all parts, and is of such design as to permit easy access to all parts.

The two spring drums are identical and interchangeable. One of these drums assembled with a spring is a completed unit and is furnished to the manufacturer in this way. To replace a broken spring it is only necessary to unscrew the screw marked A, remove the shaft B, take out spring drums and replace the drum containing the broken spring with a new drum unit. A simple operation, which could be done by any one in about five minutes.

Of particular interest is the method used in winding and locking the springs. As can be seen in the illustration, the springs are wound by means of spiral gears, which insure a smooth, silent wind. The shaft clutch spring is employed to throw the pawl against the ratchet teeth the instant the winding key is released. This holding device is positive, noiseless and foolproof.

All vibration of the turntable shaft is eliminated by means of a taper bearing at the top of the spindle and a thrust ball at the bottom end. All wear can be taken up by means of the adjusting screw on which the thrust ball rests. This taper-bearing design is the same as that used in the manufacture of precision machinery, where all "chatter" due to vibration must be positively eliminated.

The finest degree of regulation between the worm gear on the governor shaft and the gear on the turntable shaft is obtained by means of an eccentric motion of the governor shaft as a unit. Once adjusted, the position is securely held by the two set screws on the governor bearings.

The speed regulation of the turntable is obtained by turning a small knurled thumb piece on the dial plate. A number, indicating the revolutions per minute of the turntable, shows

through a slot in the plate. A small rod connects this plate with the governor regulator. The speed relations once established the rod is secured in position by means of a set screw.

This motor will play five ten-inch records with one winding, it projects only four inches down from the motor board and weighs eight pounds.

PHOTOGRAVURES OF VICTOR ARTISTS

New Series of Handsome Portraits Offered to Dealers for Display and Decorative Purposes in Their Stores and Windows

The Victor Talking Machine Co. has sent out to its dealers throughout the country a set of miniature reproductions of the handsome photogravures of Victor artists designed for use in show window and wareroom display, and which have proven so much in demand in the past on the part of both the trade and the public. Proofs of the photogravures occupy twenty-seven separate sheets, two of the sheets each bearing four pictures. Some of the photo-

gravures are furnished in 10½ by 13½-inch size, with or without frame, as desired, while others are furnished in 20 by 26-inch sizes. A special series measuring 35 by 45 inches is also offered. The artists shown in the photogravures include Caruso, Gluck, Schumann-Heink, McCormack, Kreisler, Elmon, Homer, Farrar, Galli-Curci, Paderewski, Tetrizzini, and a score of others. The photogravures are offered to the dealers either plain or framed, at what practically represents cost price, and will go to add to the attractiveness of many a store this fall and winter.

VALUE OF "CLOSE CO-OPERATION"

It is not the guns or armanent
Or the money they can pay,
It's the close co-operation
That makes them win the day;
It is not the individual
Or the army as a whole,
But the everlastin' team-work
Of every bloomin' soul.

—KIPLING.

SALTER

Salter Talking Machine Record Cabinets have been for years prime factors in their field.

The Felt Lined Shelf was our original idea. It has done more to promote the sale of records than any other one thing in the cabinet line.

Quality has always been our watchword and our organization and factory facilities enable us to realize it.

We make music and music roll cabinets too

Salter Manufacturing Co.

337-349 NORTH OAKLEY BOULEVARD - CHICAGO, ILL.

Inspections and Tests of the Heineman Motor

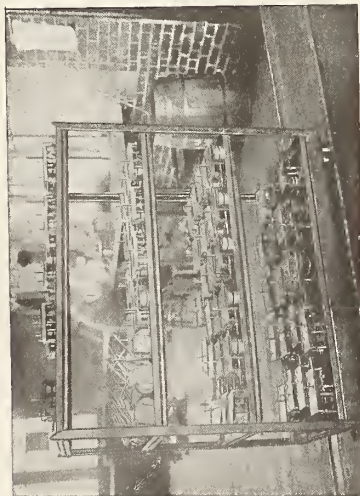

MOTORS

Cut shows motors assembled and, each part having passed through various process inspections and the motors through preliminary tests, are now ready for final assembly and initial complete inspection.

Note motors are assembled less governor and governor shaft. From this point these motors go to special sound-proof rooms for initial and final inspections.

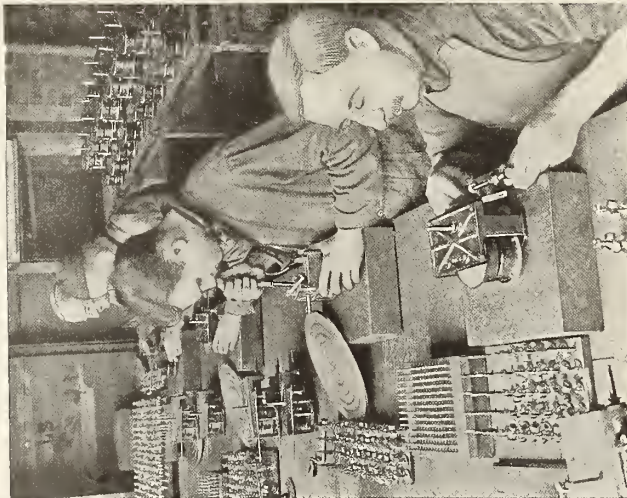

INITIAL MOTOR INSPECTION

In a specially designed sound-proof room the motors are fitted with governor, governor worm and adjusted. This room is so arranged that each operative has the best of light, special tools and the most modern equipment at his hand.

All motors are wound electrically and every one rewound to full capacity many times at this stage.

All screws are tightened and all running parts thoroughly lubricated during the process.

This work is accomplished by a trained force of highly skilled instrument makers with years of experience in this line of work.

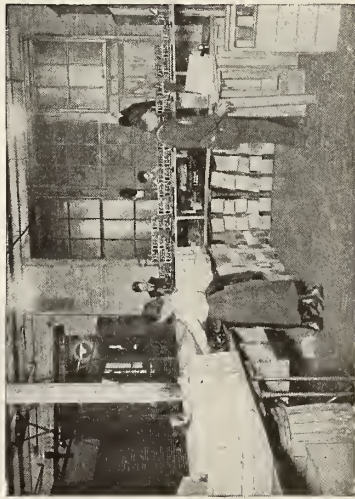

PACKING

All inspections and tests for perfect motors would be of no value if, after all, the motors were not properly packed for shipment.

Motors are carried from initial inspection room through final inspection room to packing room on trays running on tracks, as shown in above illustration.

Carefully mounted on fibre boards, using the regular mounting screws and washers, wrapped in oiled paper, to prevent dust or any foreign matter settling on the gears or, in fact, any part of the motor; placed in cartons specially designed and arranged for transporting motors in a suspended position exactly the same as when mounted in cabinets.

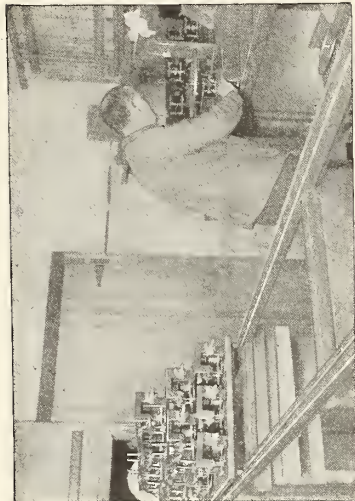

FINAL MOTOR INSPECTION

The final motor inspection is a check on all previous process inspections, every screw is tightened,—every part tested for fit and adjustment,—inspection made that each running part is thoroughly oiled and, finally, the running of the motor is tested.

The room is specially designed and sound proof,—lined with hair cloth to exclude any foreign noises, and every device known used to bring out any noise other than natural sound caused by moving parts of the motor, so that same may be corrected if in any way detrimental to a Motor of Quality.

Each motor is inspected by an expert instrument maker who tests all parts, winding device, pulling power and quietness of running. Motors passing this test are right.



RUNNING TESTS

After motors have passed the final inspection, as shown in another illustration, a certain number of each style is taken every day and given a running test. The cabinets shown above are designed to show various conditions in the motor under observation.

A careful record is kept of the number of times wound, number of revolutions at one winding and, in fact, every feature is checked that would be necessary to warrant calling each one a "Motor of Quality."

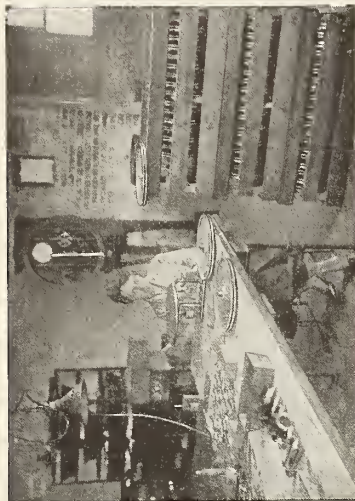

TURNTABLE TEST

All turntables used with Heineman Motors are so manufactured as to run perfectly true and felt attached so there are no irregular edges.

These turntables have the underedge trimmed and are hand balanced before the hole in the hub for the turntable shaft is drilled and tapered. Each tapered hub is tested with go and no-go gauges.

The inspection shown is the final one before packing.

The fixture on which the table turns during this operation is so arranged as to show positively any irregularity in the moving turntable.

Turntables furnished with Heineman Motors run absolutely true.



SOUND-BOX INSPECTION

Each sound box after passing all process and preliminary inspection is carefully played and tested.

The inspectors on this work are all musicians with conservatory training in music and are capable of and do reject each sound box that does not reproduce naturally and with full volume.

Combined with trained workmen and materials of selected grade, these inspections make Heineman equipment deserving of the title "Motor of Quality."

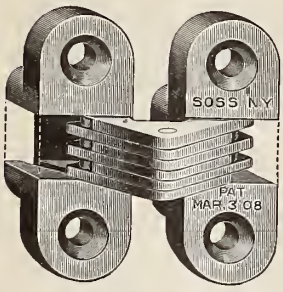

No. 103



INVISIBLE HINGES

Preserve Beauty

In many beautifully designed, finely finished Talking Machines, Pianos, Music Cabinets, Piano Players and Benches, the elimination of the unsightly protruding Hinge is essential to preserve the beauty of the design.

Design and Construction

The fine cabinet work which is required in many instances to preserve the disguise of the instrument requires that the hinges be as inconspicuous as possible. SOSS Hinges are *invisible*.

WRITE FOR CATALOGUE "T"

SOSS MANUFACTURING COMPANY, 435 Atlantic Avenue, BROOKLYN, N. Y.

DETROIT—922 David Whitney Bldg.
SAN FRANCISCO—164 Hansford Bldg.

LOS ANGELES—224 Central Bldg.
CHICAGO—John C. Bold & Co., Clark and Washington Sts., Conway Bldg.



No. 100

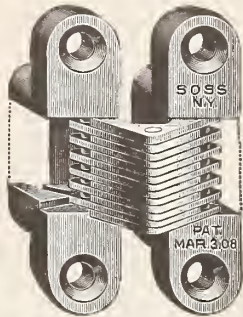

No. 101

THE KIND OF DEALER WHO WINS IN BATTLE FOR TRADE

An Illuminating Analysis of the Different Types of Dealers in Which It Is Shown How the Man Open to Ideas and Suggestions, the Balanced Man, Achieves Trade Success

[H. C. Ernst, assistant to R. J. Keith, vice-president and general manager of the New York Talking Machine Co., recently completed his first year's association with this company. Prior to joining the staff of the New York Talking Machine Co. Mr. Ernst was assistant to the president of the National Cash Register Co. and also occupied an executive position with the Stenotype Co. He is therefore a man of wide vision and unusual business acumen, and the following article which gives a brief resume of his ideas of the Victor business, after a year's connection with the industry, is worthy of more than passing attention.—Editor.]

As I see it there are four different kinds of Victor dealers:



H. C. Ernst

First, the man with vision and ability.

Second, the man with ability and no vision.

Third, the man with vision and no ability.

Fourth, the man with neither vision nor ability.

The man in class one has vision enough to see the value of proper advertising, competent help, un-

excelled service, courteous treatment of customers, drastic credit policy and, above all, absolute belief in and loyalty to Victor products.

Class one man in most cases has a DEFINITE working plan in operation. In other words, he knows what percentage of his profits he can spend for advertising each month—and he does it. He knows what percentage he can spend for his help, his deliveries and his overhead—and he does it. He knows that courtesy to his customers is a big asset—and he practices courtesy and affability. He knows that his mailing list is worth its weight in gold if it's live. He therefore works with that mailing list day in and day out, keeps on it only the names of those people who in his estimation are actually buyers. He studies constantly the trend of affairs, nationally, and takes advantage of every change in his community which will increase his business and he adjusts his mailing list accordingly. If he finds that

the working man in his community is making more money than he ever did before, he plays hard for the working man's business. If he finds that a foreign element is creeping in, he puts in foreign records. Furthermore, the class one man actually SELLS his records and machines. He knows his stock and knows the likes and dislikes of his customers. He sells 16s and 17s as well as the more expensive records because he knows how to present them. He keeps his shop neat, clean, and brings it up to the cultural standard of the merchandise which he is handling. He appreciates the value of window displays. In short, the class one man cannot help but be successful because he overlooks no opportunity whatever and he has the vision and the courage to go ahead and do things instead of waiting for some one else to show him the way.

The man in class two is unfortunate in that he can carry out what the man in class one does, but he is the kind of dealer who cannot work without direction and furthermore even with direction he would be at a disadvantage because he is fearful of results. It is this class of man who will spend \$80 on one ad and because he gets no results will stop advertising, not because he cannot devise good advertising matter but simply because he hasn't vision enough to see the value of this sort of thing and the necessity of constantly driving at the public not with one ad but with a succession of matter that will bring the customers into HIS establishment. It is this man who holds the dollar so closely to his eye that he can see nothing else. He will not invest in proper window cards, window advertising, store fixtures, etc., because he first wants to see results. He knows he should do these things, but again fear that the investment will not pay out holds him back.

The class three man—he who has plenty of vision and no ability—is as badly off as the man whose classifications are just reversed. Perhaps he is worse off. Class three man has so much vision that he never stops to figure the cost of things but allows enthusiasm to run away with him to make any investments, advertising, fixtures, etc., which cannot possibly pay out. They won't pay because after having brought customers into the store this man is unable to sell them. He is unable to impress them, probably. He has not studied his line. He is not in a position to suggest to his trade what they should have. In short, he spends his money along the right channels, but cannot produce any actual sales.

The class four man is quite overcrowded. The dealer who has neither vision nor ability may have succeeded thus far, yet he has not succeeded on account of what he has done but rather in spite of what he has done. The Vic-

tor Co. has made it possible for such a man to exist, but in these abnormal, strenuous times and in the face of the very acute shortage of goods this class four man must either pass out or sell out. The class four man cares not for the appearance of his establishment. He does not appreciate the value of a mailing list. He knows his trade perhaps, but has not a good suggestion in his make-up which would tend to make up any one customer's given library. He sells a record only because it is asked for. He hasn't the slightest conception as to how to present the higher-priced machines. He seldom reads Victor advertising. He pays little or no attention to his mail. He does not believe in spending money for advertising not because he is fearful of results but simply because things have not come easy for him and he consequently accepts his profit with the least possible effort.

The class one dealer is a man who is laying a foundation for after the war which will net him wonderful returns. It is this class of dealer who is open to ideas and suggestions and who has a strict accounting of his stock and knows exactly how his business has been running.

This enables him to order stock intelligently and to keep his stock at the highest points of efficiency in the face of a shortage. He does not buy in quantities of one and two, but rather buys for intervals of six months or a year because his books show him that he is justified in making these purchases, and naturally he need never have qualms or fears as to the salability of any of the products which he has.

The Mutual

— TONE ARMS & SOUND BOXES —

Dealers

If you want the best, be sure that the machines you handle are equipped with

MUTUAL
TONE ARMS AND
SOUND-BOXES

Mutual Talking Machine Co., Inc.
145 West 45th Street, New York

"NICHOLSON"

New Catalog Showing New Styles
RECORD CABINETS

strictly high-grade construction at prices
BELOW COMPETITION

Write for a copy of the catalog and our
special free advertising help for dealers.

K. NICHOLSON FURNITURE CO., Chase City, Virginia
Sectional Bookcases and Record Cabinets

GREAT INTEREST SHOWN IN EDISON FIELD DAY GAMES

Over One Thousand Persons Attend Successful Affair Held in Olympia Park, Irvington, N. J., Recently—Thos. A. Edison an Interested Spectator

More than four thousand persons, employees of the Edison laboratories with their families Edison handed the medals and pins to the winners from the Edison box in the grand stand.



Tug of War Between Rival Teams of Manufacturing Department "Huskies"

and friends, attended the recent Edison Field Day games at Olympic Park, Irvington, N. J. Many officials of the Thomas A. Edison industries were in the big party. Mr. and Mrs. Thomas A. Edison were inter- Music, which added zest to the athletic con-



Charles Edison Presenting Trophies to Winners of the Grand Prix relay race, 880-yard four-man relay race, firing the pistol from his box. Charles



Mr. Edison Starting Grand Prix Relay Race tests, was furnished by the Edison Employees' Band, and their harmonies added much to the day's pleasure.

GEO. E. COUGHLIN IN SERVICE

George E. Coughlin, son of J. T. Coughlin,

president of the Talking Machine Men, Inc., is a student pilot at the Naval Aviation School at Pensacola, Fla.

Bring Those Jobs Out of Hiding

The value of your "job lots" will not be increased by keeping them on your shelves.

Bring them out into the daylight. Let us sell them for you.

We are in the market to buy for cash everything in Phonograph parts, accessories, etc.

Get in touch with us at once

THE PHONOGRAPH CLEARING HOUSE, Inc.

51 EAST 42d STREET, NEW YORK CITY

DEALERS Make Big Money On Our Language Records



FRENCH, SPANISH
ITALIAN, ETC.
ALSO
F.M.C FRENCH
MILITARY
CONVERSATION

Cash in now on the

Language Phone Method and Rosenthal's Practical Linguistry

It requires no scientific salesmanship to sell our records. The courses are so simply arranged that the demonstration satisfies the prospect. The French Military Course, 5 Double Discs, and Military Manual (Retail \$10.00) is ideal for Army, Navy, Red Cross

Excellent Line for Summer Trade
Send for Particulars

THE LANGUAGE PHONE METHOD

992 Putnam · 2 West 45th Street, - New York

WANTED SOME 'UP AND DOWN' MUSIC

Berdy's Musical Knowledge Enabled Him to Meet Customer's Demand, Even Though the Description of the Record Was Puzzling

William Berdy, the well-known talking machine dealer of Brooklyn, N. Y., had a unique experience in locating a record called for by a customer who recently came to his store. The party in question had heard an instrumental selection by Mischa Elman and made up his mind to have the record; however, he was unable to name the composition and failed to adequately describe it at several stores until he reached Mr. Berdy's place of business. When he arrived he stated he wished a Mischa Elman record, and that the music of the same went "up and down." Mr. Berdy quickly judged he meant music of the cadenza type and looked up the compositions of Rossini, who is the composer of numerous works answering that description. It seems as though Elman does not play any of the Rossini works. After giving further thought to the matter he went to the record files and produced an Elman record of "Caprice Bosque," of which Sarasate was the composer and played the same much to the delight of the customer who was well pleased at finding a dealer who could understand what "up and down" meant.

The Windsor Music Co. have purchased the building in which the store has been located for some time in Tarentum, Pa. The price is said to have been \$4,000.

The Virginia Mercantile Corp., which handles talking machines on a large scale in Norfolk, Va., has changed its name to the Grafonola Shop, Inc.

MAESTROLA MAHOGANY CABINET MACHINES, SIZE 15 x 15 x 7 1/2

Motor worm gear plays 2 1/2 to 3 ten inch records, one winding. Price in dozen lots \$5.00 each, sample machine \$5.50.

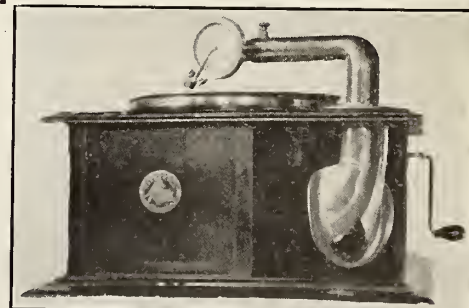

Steel needles and phonograph parts selling at the old prices during July regardless of the scarcity of these supplies. Now is the time to place your order. Be wise and save money.

FULTON TALKING MACHINE COMPANY
640 Broadway New York City, N. Y.

**The most exquisitely designed cabinets.
A new and improved type of motor unit.
And a Non-Set Automatic Stop!**

These are a few of the superiorities found in the new model Grafonolas

**Columbia Graphophone Co.
NEW YORK**



“THE IMPORTANCE AND VALUE OF MUSIC IN WARTIME”

This Subject, for Which The Music Trade Review Offered a First Prize of \$50 and a Second Prize of \$10 in Thrift Stamps, Won Respectively by A. J. Palmer and J. W. Desbecker

In order to stimulate a fuller realization of the fact that music is an essential and powerful influence in maintaining the national morale during wartime, The Music Trade Review, at the National Music Show, held in New York, June 1 to 8 inclusive, announced that a first prize of \$50 and a second prize of \$10 in Thrift Stamps would be given by this publication for the best article treating on “The Value and Importance of Music in Wartime.” Lieut. John Philip Sousa, conductor of the world-famous Sousa’s Band, and C. M. Tremaine, director of the National Bureau for the Advancement of Music, acted with the editor of The Review as judges of the various essays which were presented for consideration.

Up to the time the contest closed, June 20, a large number of articles were submitted, some of them of excellent quality, but the contest really narrowed down to about a dozen contributions from which the judges selected the article submitted by Arthur J. Palmer, assistant advertising manager of Thos. A. Edison, Inc., as entitled to the first prize of \$50 and the article of John W. Desbecker, who is in charge of plan and copy for the Redfield Advertising Agency of New York, as entitled to second prize of \$10, both of which articles recently appeared in our New York contemporary.

The Review states that the contest greatly helped to arouse interest regarding the relation of music to the great war—a topic which is certainly most pertinent to-day, when people should more fully comprehend the tremendous part music is playing and can play in augmenting not only the spirit of our fighting men but in stimulating and consoling the millions of civilians behind them.

We take pleasure in presenting these two essays to readers of The Talking Machine World:

First Prize to Arthur J. Palmer, Orange, N. J.

Food feeds the body—literature feeds the brain—music feeds the soul. To-day our souls are undergoing the greatest trial in the history of our country. Music is honey to the soul. To-day music is feeding the soul of America and vitalizing the spirit of her sons and daughters. It is helping to sweeten the bitter cup that the world now holds to its lips.

Music has become so closely woven into the fabric of

our lives that to take it away from us would tear at our very heart strings.

Music speaks in all tongues and all ears understand. It speaks to the souls of men and they respond with the noblest and purest deeds of heroism. Inspired by it they make the sublimest sacrifices with a smile on their lips. They go into battle—they go down on ships at sea singing songs.

The story of the American naval commander who coaled his ship in record time is an instance of the value of music in wartime. Though dog-tired from a long cruise which had just ended, the crew plunged into their task with a ready will and without a murmur. As the men were driving their weary, sweating bodies to the limit of endurance by sheer willpower, a happy thought struck the ship’s commander. He ordered the ship’s band to play all the while the crew were coaling. The effect was electrifying. They worked as if inspired. Faster and faster went the coaling, and when the job was done the men were completely fagged out but they had broken all time records for coaling dreadnoughts.

What an excellent illustration of the tremendous influence of music in co-ordinating the working spirit and in uplifting patriotism and sacrifice to supreme heights.

Music was never more welcome in the American home than it is to-day. At such times as the present nothing is more acceptable as the companion of our leisure hours than good music.

Not only is music in the home a great blessing now, but it is likewise an investment in future happiness and contentment. We put money into banks, we buy bonds, securities and insurance as investments against future contingencies. Why not also fortify our spiritual welfare with a constant supply of mental refreshment in the form of good music?

With music at the front, music on the seas, music in the camps and music in our homes we have a bond of spiritual strength that will defy all apprehension, disappointment and discouragement (real or fancied)—that will support to the end our resolve to purge the world of a monstrous, perverted doctrine that puts might above right—that will make unbending our determination to be stripped of all our possessions and go prematurely to our graves rather than permit the policy of the cloven-hoof to prevail on earth.

Second Prize to John W. Desbecker, New York

Music is as old as history and from the era of the first of the kings to the present time music has ever held an honored place in the life of the peoples of the earth.

When David returned from the slaughter of the Philistines “the women came out of all cities of Israel, singing and dancing to meet King Saul, with tabrets, with joy, and with instruments of music.”

The spirit of 1776 was represented by fife and drum, and to-day, headed by their pipers, the Highlanders go valiantly to the combat.

In the great hospitals, surgeons, physicians and nurses are marveling at the rapidity of recovery caused by the use of music as a daily tonic.

Music is one of the main vertebrae of human power and courage. It inspires the fighting man, it maintains the confidence and optimism of the millions behind the lines, it soothes the worried, rests the tired, and comforts the stricken.

Music appeals to the soul of mankind. It softens the hard road of existence, it brings hope and fresh vigor to the discouraged and downhearted, it revivifies, stimulates and energizes.

Music makes sweetness of sadness, lightens the weight of sorrow, encourages the weak to be strong and adds to the strength of the mighty.

At the front music causes the shell-blasted, trench-scarred landscape to vanish, and in its place, wafted by familiar, magic notes, come visions of peace and of loved ones.

In the home music keeps firm the faith, causes petty troubles to vanish, cheers those left behind, and maintains the good spirit so necessary for the utmost endeavors.

Music is needed in these war days more than ever before.

It carries us with a smile to battle; it sounds a brave and fearless song though ships go down, and hostile cannon roar, and soon, in the hour of the triumph of right—the hour of our victory—music will voice pæans of thanks to God.

Music is man’s link with the Infinite. Its powers are wonderful and are known to all.

Why is music so powerful?

This we cannot answer, but its potency for good no one can doubt.

J. H. McSHANE IN THE ARMY

J. H. McShane, formerly advertising manager of the Pathé Frères Phonograph Co., Brooklyn, N. Y., is now a member of the National Army in Camp Dix, N. J., having left for this camp as a member of the contingent from his district on July 27. Mr. McShane has passed preliminary physical tests with flying colors, and is looking forward to active service “over there” with the American Expeditionary Forces in the very near future.

TEST offered to dealers to prove the superiority of Wall-Kane Steel Needles

Take two standard disc records of the same selection, play one ten times with the same WALL-KANE loud needle; play the other record, the same selection, ten times, but with ten, new, full tone steel needles.

You will find that the record played ten times with the same WALL-KANE needle will sound clearer, will have less surface noise, and that under the magnifying glass the grooves of the record played ten times with the ten steel needles will seem to be more disturbed.

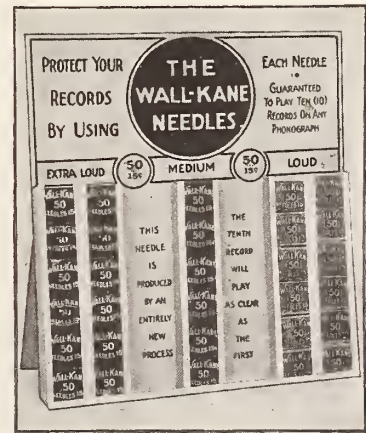

Beware of Imitations

Package of 50 WALL-KANE needles. Loud, Extra Loud and Medium, greater value than 500 ordinary steel needles, retails for 15c, cost the dealer 9½c.

Jobbing territories open

**Progressive Phonographic Supply Co.
145 West 45th Street, New York**

SCHUBERT Double Disc RECORDS

A \$30 Record Investment Starts YOU with complete, up-to-date list of Popular Vocal and Instrumental Selections

10-INCH DOUBLE DISC

20 to 30 New Selections Monthly

We guarantee you against loss of Record Investment.

Liberal Discounts Send for Details

BELL TALKING MACHINE CORPORATION

(Record Department)

44 WEST 37th STREET, NEW YORK, N. Y.

WORLD'S CLASSIFIED ADVERTISING

Any member of the trade may forward to this office a "Situation" advertisement intended for this Department to occupy a space of four lines, agate measure, and it will be inserted free. Replies will also be forwarded without cost. Additional space will be at the rate of 25c. per line. If bold faced type is desired the cost of same will be 25c. per line.

WANTED—Man between twenty-five and forty years of age with \$5,000 to invest in a corporation operating a chain of Columbia Talking Machine stores. Party must be capable of managing a branch store. Liberal salary with chance for advancement to right party. Address "Box 541," care The Talking Machine World, 373 Fourth Ave., New York.

SALESMEN WANTED—If you cover the phonograph trade in any section of the United States and are interested in a live proposition, either as a side line or as your main line, we have an interesting offer. In answering state territory now covered. Address "Box 522," care The Talking Machine World, 373 Fourth Ave., New York.

SALESMAN, experienced, wants position with phonograph house. Knows the music, piano, furniture and department store trade in the entire South and Middle West; fine reference. Address "Box G. R.," care The Talking Machine World, 373 Fourth Ave., New York.

POSITION WANTED—Talking machine salesman or manager, nine years' experience, inside position. New York or Brooklyn preferred. Can furnish best references. Address "Box 526," care The Talking Machine World, 373 Fourth Ave., New York.

POSITION WANTED—Manager of phonograph department open for place. Now employed. Can bring two good salesmen with him. Address "Box 527," care The Talking Machine World, 373 Fourth Ave., New York.

POSITION WANTED—Expert in hill and dale and lateral recording. Have sample of work that shows superior quality, also knowledge of latest methods of plating and familiar with every detail of record making. Address "Box 528," care The Talking Machine World, 373 Fourth Ave., New York.

POSITION WANTED—Sales or advertising manager with Chicago talking machine manufacturer or local representative for outside concern. Experienced. References. Address "J. N. 6," care The Talking Machine World, 209 South State St., Chicago, Ill.

POSITION WANTED—An exceptionally good talking machine repairman seeks new position. Will go anywhere. Address "Box 529," care The Talking Machine World, 373 Fourth Ave., New York.

SALESMEN wanted who are desirous of making big money selling standard records. Address "J. N. 8," care The Talking Machine World, 209 South State St., Chicago, Ill.

POSITION WANTED—By wholesale phonograph and piano salesman. Open for position to travel east of Chicago. Held last position 2½ years. Phonograph position preferred. Best of references. Address "Box 536," care The Talking Machine World, 373 Fourth Ave., New York.

POSITION WANTED—Salesman or tuner. Highest references. Capable branch house management or piano, talking machine or musical instrument department. Age 42. Salary and commission. Address "Box 537," care The Talking Machine World, 373 Fourth Avenue, New York.

SITUATION WANTED—By an experienced talking machine man, experience of ten years, Europe and United States. Has been doing work for some large manufacturing concern—live salesman; mechanic. Address Universal Talking Machine Co., 5021 Baltimore Ave., Philadelphia, Pa.

SITUATION WANTED—Salesman, live wire, special experience in foreign records. Knows the business from A to Z. Address: Universal Talking Machine Co., 5021 Baltimore Ave., Philadelphia, Pa.

DEPARTMENT MANAGER—Eight years' experience Victor, Columbia and Vocalion. Now employed. Will be open for change September 1. Address "A. U. 7," care The Talking Machine World, 209 South State St., Chicago, Ill.

SITUATION WANTED—By expert with eleven years' experience in all branches phonograph line, making, assembling and repairing. Can take complete charge of mechanical end. Had charge of some of large concerns in the manufacturing and assembling from motor to complete machine. Am a good systematizer and organizer. Address "A. U. 1," care The Talking Machine World, 209 South State St., Chicago, Ill.

SITUATION WANTED—Who can use a high-class manager, either wholesale or retail, capable of taking exclusive charge and producing results? Have had over ten years' experience, willing to locate anywhere. Address "Box 540," care The Talking Machine World, 373 Fourth Ave., New York.

SITUATION WANTED—Salesman (35) acquainted with every angle of the business. Phonographs, records and sundries. Vigorous result getter on road. Drawing account against commission. Address "Phonographs," 22 East 125th St., New York.

POSITION WANTED—Talking machine salesman, five years' experience. Inside position large city preferred. Familiar with all well known machines. References. Address "A. P. 2," Talking Machine World, 209 So. State St., Chicago, Ill.

WANTED—Thoroughly experienced, aggressive Edison, Victor and Columbia manager is open to manage department. Any location. Success guaranteed. Address "J. L. 8," care The Talking Machine World, 209 South State St., Chicago, Ill.

THRIVING VICTOR BUSINESS FOR SALE
Good, live Victor store in hustling western Pennsylvania town of 12,000, growing very rapidly, with many good industrial plants which are developing very fast. Excellent location, new equipment, booths, etc. Stock in A-1 condition. Other interests make sale imperative. Will sell for cash to quick purchaser at inventory, which totals about \$4,500. Address "Box 544," care The Talking Machine World, 373 Fourth Ave., New York.

WANTED
Main springs, governor springs, micras, fibre gears, bevel gears, screws and all parts used with Columbia motors. The Music Supply Co., Columbia distributors, 36 Welling St., East, Toronto, Canada.

FOR SALE
\$500.00 buys complete dies and tools for phonograph motor, plays one 10-inch record. Sample motor \$1.00 each. Address "Box 542," care The Talking Machine World, 373 Fourth Ave., New York.

FOR SALE
700 Master Records, consisting of all the Paroquette 7-inch Masters and all the Majestic 7-inch Masters, in good condition. These Masters cost about \$75,000 to make—will sell at exceptional bargain.
Address Box 539, care of TALKING MACHINE WORLD, 373 Fourth Ave., New York

MAIN SPRINGS AND PHONOGRAPH PARTS

Steel Needles (100 in envelope), per 1,000 needles	0.65
Sapphires, for Pathé or Edison, each	0.25
Genuine Diamonds for Edison Disc, each	1.75
MAIN SPRINGS	
For Edison Motors, size 1½", each	\$1.75
For Columbia Motors, size 1"x0.28x10", each	0.60
For Columbia Motors, size ¾"x0.23x9½", each	0.30
For Columbia Motors, size ¾"x0.22x8½", each	0.24
For Mermod Motors, size ¾"x0.22x8", each	0.35
GOVERNOR SPRINGS	
For Columbia Motors, bent, per 100	1.50
For Victor Motors, per 100	1.50
THUMB SCREWS FOR STYLUS BARS	
For Victor Soundboxes, per 100	1.50
For Columbia Soundboxes, per 100	1.50
MICA DIAPHRAGMS	
For Victor Soundboxes, each	0.15
For Columbia Soundboxes, each	0.25
For all standard Soundboxes, each	0.22
NEEDLE CUPS	
Needle Cups, nickel plated, per 100	2.00
Covers to nickel cups for used needles, per 100	1.25
Green Felt for 10" turn-tables, each	0.10
Green Felt for 12" turn-tables, each	0.15

FAVORITE PHONOGRAPH ACCESSORY CO.
1491 DeKalb Avenue Brooklyn, N. Y.

WANTED
Records in all Languages, Talking Machines and Accessories. Spot Cash Paid
Victoria Record Exchange, 2104 Third Ave. Phone 7848 Harlem NEW YORK CITY

FOR SALE
2,000 pounds best motor springs ¾"x0.16 E. H. C. grade in standard coils. Right price to quick buyer. Address "Box 543," care The Talking Machine World, 373 Fourth Ave., New York.

EDISON PHONOGRAPHS—Thirty-five "Home" models, with 2-minute attachment. Unusual opportunity for Edison dealer. Write us at once. Grinnell Bros., Victrola and record distributors, First and State streets, Detroit, Mich.

EDISON RECORDS—Assortment of 14,000 4-minute selections. Don't fail to learn of this special. Write immediately for particulars. Grinnell Bros., Victrola and record distributors, First and State streets, Detroit, Mich.

"THE REPRODUCTION OF SOUND"

There has just been published by W. B. Tattersall, Ltd., London, Eng., a most interesting volume on "The Reproduction of Sound," being a description of the mechanical appliances and technical processes employed in the art. This new volume, which is most comprehensive in character, and deals with the making of both silver and disc records, as well as the mechanics of the reproducing means and the construction of the motors, etc., has been written by Henry

Seymour, a recognized authority on the reproduction of sound by mechanical means.

The volume of over 300 pages is carefully printed on coated paper and profusely illustrated. It is bound substantially in cloth. It is believed to be the first time that all phases of sound reproduction by means of phonographs or gramophones have been treated of in one volume. The published price is 10/6.

A SIGNIFICANT LETTER

George E. Brightson, president of the Sonora Phonograph Sales Co., New York, received recently a copy of a letter sent by the Winter Piano Co., of Milwaukee, to the Yahr & Lange Drug Co., of that city, Sonora distributors. This letter, which constitutes a pleasing tribute to the salability of Sonora product, reads as follows:

"Referring to your letter of recent date regarding the Sonora and our experience with the line, would say that we have been very agreeably surprised. Putting in a new line that we have never pushed outside of a few 'ads' in the newspapers, and only small 'ads' at that, we

sold nearly worth of Sonoras in less than a month. We consider this quite remarkable, especially considering the time of the year, being right in the middle of the summer, when the music business is so very dull. What surprises us most is the kind of trade that demand the Sonora. It is always the better class, that either pay cash or make very large initial payments, making it very easy to finance the business. With best wishes, believe us to be, etc."

Record Delivery Envelopes
Safe - Swift - Secure



The heavy paper means protection; the button and cord mean speed—you can wait on more customers.
Bring out YOUR OWN NAME. Every time an envelope leaves your store, let the advertisement on it take your name to the homes and bring new trade. The advertising more than pays for the envelope. Write for samples and prices.
Lewis C. Frank, 694 Book Bldg., Detroit

NEEDLES
WE MANUFACTURE
Diamond needles for Edison
Sapphire needles for Edison
Sapphire needles for Pathe
in stock ready for delivery
MERMOD & CO., 505 5th Ave., N. Y.

FROM OUR EUROPEAN HEADQUARTERS

2 GRESHAM BUILDING, BASINGHALL STREET E. C., LONDON, W. LIONEL STURDY, MANAGER.

Organization of the Association of Gramophone and Musical Instrument Manufacturers and Wholesale Dealers Marks New Epoch in British Music Trade—Prominent Men as Executives—President Ricketts Reviews General Situation in Trade—Luxury Tax Proposals Receiving Earnest Attention—Trade Members Protest—What the New Record Lists Offer—Annual Music Trades Convention—Publicity Matter Curtailed—General Trade News

LONDON, ENGLAND, July 27.—If at any time the history of the gramophone trade is recorded in chronological order, according to the sequence of events in their degree of importance, I am inclined to believe that the outstanding feature of the greatest trade import during the last six or more years will be universally accorded to the inauguration of the Association of Gramophone and Musical Instrument Manufacturers and Wholesale Dealers, whose first general meeting took place last month. The establishment of this association is supported by powerful interests, its chosen executive officers having been selected from the more prominent firms representing each section of the music trade industry, and thereby well qualified to speak for the trade at large.

M. E. Ricketts (the Gramophone Co., Ltd.), was elected as president for the ensuing year; Frank Samuel (Barnett Samuel & Sons, Ltd.), vice-president; Walter Beare, treasurer, and C. B. Timms, honorable secretary of the committee. The gramophone trade is represented by W. Manson (British Zonophone Co., Ltd.), J. E. Hough (Edison Bell), Louis Sterling (Columbia Co.), on the manufacturing side, and the wholesale dealers' section by George Mur-

doch, E. C. Paskell (Colmore Depot, Birmingham), and H. J. Cullem.

The membership at the time of writing totals about 100 of the leading music trade houses in London and the Provinces. New members are being enrolled day by day, and as far as this consideration goes, the new association is already firmly placed on a foundation of sound and healthy prospect to enable it to carry on satisfactorily its good work.

The first general meeting, ably presided over by Frank Samuel, was very well attended and great interest evinced by all present in the subjects which came up for discussion.

Mr. Rickett's Historical Survey

A good deal of time was taken up with the election of officers and discussion on the rules of the association. This part of the proceedings I am constrained to omit from my report, owing to pressure on space, and the desire to publish as full a statement as possible of the interesting speech made by Mr. Ricketts, who (in part) said: "Mr. Chairman and Gentlemen, I think that the majority of you are aware of the conditions that have led up to the formation of this association, but it will not be amiss if we just roughly run through the difficulties to which you and the British music trades industry committee, of which your association now forms part, has acted on your behalf. The whole thing dates back to March, 1916, when we first had information from the Board of Trade that they were going to stop the imports of gramophone musical instruments and parts thereof. Therefore, we formed a committee, which approached the Board of Trade, and eventually the Board of Trade received our deputation on April 3. The result

of that deputation was not very successful to us. It was not until May 13, when we had a further interview with Sir John Bethell, and, as a result of that, permission was given to import 124 shipping tons per month from America and Canada. The committee were authorized by the Board of Trade to apportion this concession between the various manufacturers in the music trades industry. On September 16 we had that increased to 130 tons, and early in 1917 the Board of Trade considered it necessary that the original concession should be reduced. Further strong representations were made from the committee, and after an interview with Colonel Karslake on February 27 it was then decided to allow the industry to continue to import under the existing arrangements, on a reduced basis of eighty tons per month. In February of this year the Board of Trade intimated that the trans-Atlantic tonnage must be further reduced from eighty tons to forty tons per month, but this the committee ultimately got increased to fifty tons, but that has not been of very great use to us, because of the lack of shipping space. And we are now in close touch with the ministry of shipping to get the space in which to bring the goods over. Swiss tonnage the Government prohibited from coming into the country. Each time we approached them they said they could not allow that. But they were willing to allow us 50 per cent. of the orders placed before the date of their prohibition. We found that this 50 per cent. represented 700 tons dead weight. Although they would not give us the 200 tons asked, they were quite willing to give us 700 tons. They stuck to their bargain. That ran

(Continued on page 100)



"His Master's Voice"

Copyright

'His Master's Voice'

—the trade-mark that is recognized throughout the world as the

HALL-MARK OF QUALITY

Branches

DENMARK: Skandinavisk Grammophon-Aktielselskab, Frihavnen, Copenhagen.

FRANCE: Cie. Française du Gramophone, 115 Boulevard Richard Lenoir, Place de la République, Paris.

SPAIN: Compañía del Gramófono, 56-58 Balmes, Barcelona.

SWEDEN: Skandinaviska Grammophon-Aktiebolaget, Drottning Gatan No. 47, Stockholm.

RUSSIA: The Gramophone Co., Ltd., 45, Nevsky Prospect, Petrograd (Petersburg); No. 1 Solyanka, Solyanoi Dvor, Moscow; 9, Golovinsky Prospect, Tiflis; Nowy-Swiat 30, Warsaw; 33, Alexandrowskaya Ulitsa, Riga; 11 Michailovskaya Ulitsa, Baku.

INDIA: The Gramophone Co., Ltd., 139, Bal-haghatta Road, Calcutta; 7, Bell Lane, Fort, Bombay.

Great Britain:

The Gramophone Company, Ltd.
HAYES - MIDDLESEX - ENGLAND

Agencies

AUSTRALIA: S. Hoffnung & Co., Ltd., Sole Concessionaries of The Gramophone Company, Limited, 163, Pitt Street, Sydney.

NEW ZEALAND: Gramophonum, Ltd., 118-120 Victoria Street, Wellington.

SOUTH AFRICA: Darter & Sons, Post Box 174, Capetown; Mackay Bros., Post Box 251, Johannesburg; Mackay Bros. & McMahon, Post Box 419, Durban; Ivan H. Haarbuerger, Post Box 105, Bloemfontein; Franz Moeller, Post Box 108, East London; B. J. Ewins & Co., Post Box 86, Queenstown; Handel House, Kimberley; Laurence & Cope, Post Box 132, Buluwayo; The Argus Co., Salisbury.

EAST AFRICA: Bayley & Co., Lourenzo Marques.

HOLLAND: American Import Co., 22a, Amsterd Veerkade, The Hague.

ITALY: A. Bossi & Co., Via Orefici 2, Milan.

EGYPT (Also for the Soudan, Greece and the Ottoman Empire): K. Fr. Vogel, Post Box 414, Alexandria.

This intensely human picture stands for all that is best in music

—it is the "His Master's Voice" trade-mark, and it brings to you, no matter where you are, the very best music of every kind, sung and played by the world's greatest artists—the greatest singers, pianists, violinists, orchestras and bands—all enshrined in the unequalled "His Master's Voice" records

FROM OUR LONDON HEADQUARTERS—(Continued from page 99)

out about July 12 last year, and we approached the Board of Trade again, and they granted 50 per cent. of the 50 per cent. which brought it down to 350 tons. This concession is practically exhausted now, and we are just applying for it to be renewed.

Metal for Needles and Mainsprings

"As you know, the committee have dealt with the question of needle wire, and we were successful in getting the importance of this section of the industry recognized, and we secured a grant of metal through the recognition for the manufacture of needles. In the latter part of 1917 the question of steel for the manufacture of mainsprings had to be seriously considered, and after considering the matter with the advisory sub-committee and the industries committee, we were successful in securing a grant of one ton per month for the replacement of these very necessary parts. The committee also secured favorable consideration for the musical instrument manufacturer, both with regard to import and metal for manufacturing.

"The industry is now, I consider, definitely in the position of a national industry. The more we fight and band ourselves together to insist that not only the Government, but the press and people of this country, shall recognize that this is a national industry the better. You can trace the value of it from General Foch downwards. You will remember that General Foch, speaking after the wonderful defense of Verdun, said the result was mainly due to the inspiring effect of the bands that went up to the front to encourage the men. You can find letters on the files of almost every one, of the hospital, hospital ships, hospital trains, the bands that went to France and across to Italy—in every section you will find that music has had a real effect in keeping up the spirit and morale of the nations.

Concerning the Luxury Tax

"The committee has also represented your industry to the select committee of the House of Commons dealing with the luxury tax, and I do hope they have been successful in securing favorable consideration in this instance. It may be necessary for another deputation to go and see the select committee on this question, but I am certain that we have secured a fair and reasonable method of taxation. What it will be I do not know, but at any rate they were very sympathetic.

"We have been promised this association for years. We have been threatened with it almost for years, but still, as the man from Lancashire said, 'Nawt happened.' I remember Mr. Hough being present and presiding at a meeting held fourteen or fifteen years ago when he tried to form this association. Now I think it is only gracious of us to mention, at this point, the work of Mr. Samuels and Mr. Beare in bringing a concrete body to join together in our industry to work for one great end. We are here to develop the industry and to make it

as strong and as great a body as we can; so great a body that it can never be challenged from outside. If we are going to hold it and develop it we must do so to the best of our ability.

The Objects of the Association

"The aims of the association are to appoint delegates to the music trades industries committee, or any other body that may be formed to succeed that committee; to confer with any authoritative body; or to elect delegates to any other body that may be formed to succeed the British music trades industries committee. Perhaps there will be promoted a Federation of Music, which will carry on for the next fifty or sixty years, when the British music trades industries committee is abandoned. That is one of the objects of the British music trades industries committee, and you will have to elect your members to any body that may be appointed to confer with the ministry of munitions regarding supplies of raw materials during the period of the war; to confer with the ministry of reconstruction on the question of the supplies of raw material post-war; and also to make a recommendation to this ministry with regard to priority of demobilization of labor after the war. That is going to be a very great point. Priority of material we must insist on, as a national necessity, otherwise it will be impossible to secure material for post-war development. Also to confer on the question of demobilization of the army, or you may not get the labor back, and the class of labor you really want. It will also confer with the Board of Trade relative to tariffs, import and export conditions, the state of trade in foreign and Colonial markets, and the class of goods required, and earnestly to endeavor to obtain fair conditions which will permit British manufacturers and wholesale dealers to protect and secure all their interests."

A Meager Official Report

The official report supplied was very little more than a summary of the proceedings, and it is therefore only fair to acknowledge that for the main part of Mr. Rickett's speech I am indebted to the Talking Machine News, in which journal it is to be found a verbatim report.

The secretary of the association informs me that it is proposed to issue a monthly or occasional news letter containing items of special interest to members of the trades concerned.

Apropos the Luxury Tax Proposals

Most of us would experience little difficulty in arriving at an approximate idea of what might be reasonably regarded as a luxury. At least, so one would think. But from recent signs and hints of the official view, we should probably find ourselves very much wide of the mark. When it is said that such things as books, the membership of a club, etc., are believed on good authority to be included in the official definition of luxuries, it will be appre-

REX GRAMOPHONE CO.
are making a Specialty of
EXPORT
in
Horn, Hornless & Portable Disc Machines
REX GRAMOPHONE CO., 2 Elizabeth Place
Rivington Street, LONDON, E.C. 2
Cable Address "Lyreco-disc, London" Enquiries Solicited

ciated that our ideas need revision. There is no doubt that when the committee's findings are available, the result will materialize in more far-reaching conclusions than was at first generally expected. In the circumstances the gramophone and other sections of the music industry will almost certainly come under the impost, and to that view, the trade has already resigned itself, to the extent, any way, of sending a deputation to place before the Government committee the position and claims of the music industries for favorable treatment. What success has attended the deputation it is, of course, impossible to say beyond the satisfaction of knowing that fair and reasonable treatment may be expected as a direct result of the good case made out on behalf of a war-hit industry.

It will be necessary to introduce and pass a bill through Parliament before any tax can be operative, and from information received it can be said that the tax will not be retrospective, except perhaps in respect to a few cases which permit of easily traced and collectable duties. The Chancellor has stated that he is unable to make a definite pronouncement as to the intention of the Government in regard to the Luxury Tax bill, but that it would not be practical to introduce the measure until after the Parliamentary recess.

The select committee appointed to frame a proposed schedule of articles subject to the tax has now completed its inquiries, and a draft report has been prepared. Its discussion may last over a fortnight in Parliament, and the final recommendations will be embodied in the bill, which it is thought may not become seriously operative until the autumn, when its final authorization, the King's assent, will be given.

It is now definitely known that all scheduled articles from a shilling upwards shall carry a tax averaging on the basis of graduation two-pence in the shilling, approximately 17 per cent. on the selling price. On this basis and at the present volume of output it may be that the total contributions of the gramophone trade will be little short of £100,000 per annum!

London Retail Traders' Association Dissents

The following is an important resolution passed by the above association: "That this association is of opinion that the suggested luxury tax should be strongly opposed on the ground that, whatever its precise nature or incidence, the tax will have to be collected, either directly or indirectly, by the retailer, upon whom it will throw an additional burden at a

EDISON BELL

WINNER

TRADE MARK



GRAMOPHONE RECORDS

CABLE
"PHONOKINO,
LONDON"

ARE THE GREATEST VALUE FOR MONEY PRODUCED IN GREAT BRITAIN

TEN INCH

DOUBLE SIDED

NEEDLE CUT

PLAY ON ALL GRAMOPHONES

Catalogue contains 4000 Titles by the Premier Artistes, Instrumentalists, Orchestras and Bands of the British Empire

DEALERS PREPARED TO DO BUSINESS ARE INVITED TO COMMUNICATE WITH

Proprietors and Manufacturers, J. E. HOUGH, Ltd., 62 Glengall Road, London, S. E. 15, England

FROM OUR LONDON HEADQUARTERS—(Continued from page 100)

time when he is understaffed and already being asked to assist the Government in many ways; that the members are of opinion, however, that the only practical method is that, if adopted, the tax should be imposed on high priced luxury articles alone; that the tax, if adopted, should be enforced in such a manner as to insure that it is paid by the public; that the Chancellor of the Exchequer be requested to receive a deputation on the subject."

The Opposition of the Press

The Government's luxury tax proposals have by no means met with general acceptance. Resistance is offered by gramophone firms, piano houses and music publishers on the ground, mainly, that music is not a luxury these war-times, whatever it was before. The case is aptly put by the editor of the "Musical Times," who, in a letter to the Daily Telegraph, says: "The article in your issue of Wednesday last on the threatened application of the luxury tax to books will be very difficult, if not impossible, to answer. But do not all the powerful objections you advance to a tax on books apply equally (I am tempted to say in a greater degree) to musical publications, not only such as are definitely educational, but also to the kind that has brought cheer, inspiration, incomparable solace, and uplifting to every class of the community? A cloud of witnesses could show that music has been discovered to be one of the great social assets of the war. Already the art, through the amusements tax, is contributing substantially to the State, and the portentous increase in the cost of paper and production has necessarily acted as a drag on its activities. Should it be further discouraged by being branded as a luxury? One could better understand a proposal to tax it as a necessity." The same remarks apply equally anent the tax to gramophone records!

"Guardman" Record Factory in Full Swing

During a recent conversation with the Invicta Record Co., Ltd., manufacturers of the Guardman records, we were informed that the factory, which was rather seriously damaged by fire some time back, is again working normally. The necessary rebuilding and repairs were at once put in hand, and notwithstanding the many difficulties experienced the work was completed in good time. Output is now almost up to pre-fire working, and the company expect to reach maximum deliveries well ahead of the coming season's rush. To say the least, it is a matter for congratulation that such a large plant is again in satisfactory working order, especially in view of the fact that generally the record demand is greater than the supply. As mentioned in last month's report the Invicta people have issued some splendid quality new discs, twelve-inch double-sided. All oversea traders should write the company for full particulars.

The Eighth British Music Trades Convention

This year's convention was held in London,

and lasted two days, June 26 and 27. It was fairly well attended. Owing to the short time available, the speeches, reports, papers, discussions and matters generally were cut to the minimum. There arose few points of particular interest to the gramophone trade, though, of course, the convention attracted delegates from all sections of the music industry. J. A. Murdoch presided.

He said upon their deliberations now and in the immediate future depended their continued existence. August, 1914, marked the end of the trade world as they had known it. From their now federated board they hoped to link together the various musical associations in Great Britain and Ireland, and to evolve an industrial council. L. A. Paish, from the Department of Overseas Trade, spoke on the subject of co-operation, and referred to the case of a professional man who had adopted a foreign name in order the better to secure engagements on the London stage. He thought the time was going, if it had not already gone, when a man with long hair and a foreign appearance was necessarily regarded as a good musician.

Landon Ronald, speaking at the luncheon, said the status of British music had tremendously improved through the war with Germany. He wished to see in this country a Minister of Fine Arts appointed, and he desired also to see a halfpenny rate put on every ratepayer towards the music of the country. The conference directed the president to forward to the Government a request that the luxuries committee should place a tax of 50 or 60 per cent. on all German pianos and German music and on the fees of German musicians and professors.

Columbia Record Output Assured

In recent conversation with the Columbia Graphophone Co. it was ascertained that there is every expectation of reaching a normal output of records in good time for the coming season's trade. The recent destruction of the factory by fire temporarily disorganized Columbia plans for a big selling campaign, but owing to the promptness with which the situation has been handled, and a combination of fortunate circumstances in the utilization of certain resources, excellent facilities for manufacture having been found available by arrangement, the near future may witness a splendid resumption of output. To all dealers it will be good news and especially so to those who have loyally preserved the Columbia trade by the energetic maintenance of stock sales.

News of "His Master's Voice" Doings

This company's interesting little house organ "The Voice," is, as usual, this month full of chatty items anent the doings of "His Master's Voice" and its agents. For instance, it is mentioned that "the company's monthly board meeting fell on the twentieth anniversary of the day the Gramophone Co. commenced its business at 31 Maiden lane, London, W. C.

Soundboxes

If you are after a genuine offer of soundboxes, you'll do well to communicate with us immediately. We have tens of thousands of perfect soundboxes, fitted with the best quality mica. Confidently recommended for cheaper machines, absolutely reliable and give excellent reproduction. Price to clear \$50 per gross, F. O. B. London.

Orders for less than gross lots not accepted

Wire "Knotaslepe, London".

W. H. Reynolds (1915) Ltd.

45, City Road, London, E. C.

Write for new illustrated Complete Catalogue

(May 8, 1898)." Twenty years of development, and still progressing! It simply means that music—call it "mechanical" if you like—is yet capable of higher achievement as an art, and that while the depths of science have been probed deeply, the well of progressive development is by no means exhausted. May the bonds which link science and art as exemplified in the gramophone be strengthened for the good of mankind.

Curtaiment of Publicity Matter

Owing to the acute shortage of paper the Gramophone Co. has been obliged to reduce its advertising literature, circular letters, pamphlets, leaflets, posters, etc., to the absolute minimum. In future, communications with the dealers will be made only upon essential matters of vital mutual concern.

This announcement in "The Voice" is judiciously followed by a word of advice as to the necessity of retailers making selective use of all advertising matter received, exercising the utmost care in its distribution, and above all, to avoid waste. So absolutely important is the need for economy that every dealer should utilize his parcels of publicity matter with the same care and judgment as he would if it had been supplied at his own expense. Being free of all cost and knowing the present circumstances of difficulty involved in the issue of any publicity literature at all these times, the least that can be expected of dealers is that they will appreciate the friendly counsel proffered and act accordingly.

"His Master's Voice" Record New Success

The new Gaiety Theatre production, "Going (Continued on page 102)

GUARDSMAN RECORDS

REGISTERED

10 inch and 12 inch Lateral Cut



TRADE MARK

We can ship you immediately, any quantity of Records:

BANDS ORCHESTRAS INSTRUMENTAL SOLOS VOCAL

WIDE SELECTION OF CLASSICAL AND POPULAR TITLES

The Latest American and British works are promptly recorded by the best artists of the day.

Get a trial lot at once (your regular orders will follow) and secure yourself for the coming season's trade.

Apply for Lists and Prices to INVICTA RECORD COMPANY, Ltd.

Cables: Duarrab, London

1 New Inn Yard, London, E. C., England



YE "POPULAR" RECORDS

LONDON'S LEADING VALUE!!!

Double-Sided Superb Needle Cut "Lateral"
"OUR POINTS" SET OUT BELOW

Have Attracted Keen Overseas Houses

from SCANDINAVIA to PATAGONIA
 AND THE PRINCIPAL
 EAST and WEST MARKETS of the WORLD

REMEMBER **You Can Have CLOSE QUOTATIONS**
 For 5,000 Lots and up Your Selection or a Sample
 1,000, 75% "Bands and Orchestrals."

POINTS

- ➔ Repertoire Apprx 2,000 Titles
- ➔ Superb Selection, Bands and Orchestrals
- ➔ Lightning Shipments under Government Export License
- ➔ Packing by Experts
- ➔ **Rock Quotations "Always"**
- ➔ F. O. B. London
- ➔ We attend to all Insurances "if Requested" to Buyers A/c
- ➔ Our Shipping Services, **this Side FREE**

Address: SOUND RECORDING CO., Ltd.
EXPORT DEPT., 18-19 Swallow Street
Piccadilly, London, England

CABLES "Grammavox"
London

QUOTATIONS CABLED FREE

FROM OUR LONDON HEADQUARTERS—(Continued from page 101)

Up," has been pretty fully recorded on "His Master's Voice" records exclusively by the original artists of the piece. The outcome is a series of as fine a set of records as one could wish to hear, full of melody, and witty into the bargain, the words and music are throughout captivating, being exceptionally suitable for the making of good records. The bon mot of "Going Up" is generally acclaimed as "The Tickle Toe," Marjorie Gordon's new song.

By the time these lines appear the Gramophone Co.'s new lists of special instrumental records will be in full swing, and plans are under way for the usual publicity campaign during the autumn season.

The "Winner" Word Competition

An interesting little competition for users of records has recently been promulgated by the Winner Record Co. A square is formed by the words, Winner at the top and left side; the word record being at the bottom and right thereof. The intervening space has to be filled in with words making a readable sentence. For each of the best six sentences submitted a prize of one dozen twelve-inch discs is offered. Participants may apparently include both dealers and the public. Not a bad idea for stimulating one's thoughts of Winners.

The New Zonophone Records

1918 Supplement No. 3 by the British Zonophone Co. represents a wonderful diversity of vocal and instrumental numbers by picked artists of popular renown. They are all ten-inch records, the first on the list being selections from the "Gaiety" musical comedy, "Going Up." In addition to the foregoing the Black Diamond Band is also responsible for another good double carrying excerpts from popular airs as, for instance, "Somewhere in Blighty," "The Kiss That Made You Mine," "Until We Meet Again," etc. Sydney Coltham's rendering of "Genevieve" and "Roses of Picardy," accompanied by the Royal Cremona String Orchestra and piano, is truly exquisite. Zona Vevey is back in the list with two attractive items of military flavor—"If I Answer the Last Roll Call" and "The Lads From Our Village," both of which, by the way, are compositions of merit, by her husband.

There are many other really excellent records

of the quick-selling class by eminent artists like Harold Wilde, Miss Freda Fairchild, Herbert Payne, Ernest Pike, Peter Dawson, Florrie Forde, Harry Fay and Charles Penrose.

Columbia Graphophone's War Services

A unique testimony to a Columbia graphophone has been received from a captain in the R. F. A. at the front. He writes to the Columbia Co.: "The following record of services of one of your instruments purchased in 1916 at Manchester may be of interest to you; it has been in the Battery Mess all through the latter part of the Somme—actually in Mouquet Farm itself, chased in the spring of 1917—was in the Battle of Arras, on Easter Monday, 1917—at Bullecourt—through the Messines push and cheered us up throughout three months of the Ypres fighting last autumn. I cannot give particulars of the recent services, but they have been equally strenuous, the machine is still in good condition on the whole, but somewhat worn. It emerged undamaged on one occasion when the Mess received a direct hit from an eight-inch shell which blew in one end of the dug-out, and has successfully withstood three heavy gas bombardments."

London Store Installs Fifteen Audition Rooms

Those of us who have been privileged to closely inspect the music saloons of the great London stores are well acquainted with the excellent organization and up-to-date methods adopted for the convenience of patrons when trying over music or entertaining the purchase of a musical instrument. Most of the stores

have adopted the audition room principle for the gramophone side of the business, and with such success that at least in one case—Messrs. Harrods—new extensions are under way. According to "The Voice," this enterprising house have at present in hand the construction of no less than fifteen new audition rooms, sound-proof, and equipped on the latest lines!

America's "Call" to Great British Conductor

The recent invitation to Sir Henry J. Wood to take up the leadership of the famous Boston Symphony Orchestra was the occasion of many spontaneous tributes to the esteem and popularity in which he is held. We are glad to say, however, that Sir Henry has decided to stay here and continue his good work in London.

Trade Catalogs for Canada

H. M. Trade Commissioner for Canada reports that the most useful size for trade catalogs is 8½ inches by 11 inches, or 9 inches by 12 inches, these being the sizes most handy for filing purposes. A comparatively small yet important tip to manufacturers. It would be very advantageous if all catalogs were kept to a uniform standard size and thus encourage the retailer to keep a special file handy for reference purposes.

Parcel Rates to Oversea Possessions

It is announced by the Postmaster General that the rates of postage on parcels for dispatch to British East Africa, Uganda and Zanzibar are as follows: Not exceeding three pounds in weight, 1/6; seven pounds, 3/-; eleven pounds, 4/6.

TO DEVELOP FOREIGN TRADE

Manufacturers, With Sales of \$100,000,000 a Year, Begin Latin-American Campaign

Announcement was made late last month that forty-four manufacturers, whose domestic sales aggregate annually \$100,000,000, had formed a combination to develop foreign trade to be known as the Allied Industries Corp. The announcement said that Alfred I. du Pont, of Wilmington, Del., who recently purchased the Grand Central Palace, headed the new enterprise, and that the corporation would have its headquarters in the exposition building in New York.

Agents will be sent to Central and South America, Cuba, Porto Rico, Dominican Republic, Philippines, and the Straits Settlements to introduce the goods of the manufacturers represented in the combination, which was made possible by the Webb-Pomerene law signed recently by President Wilson.

In addition to pushing American goods abroad, the plan contemplates a reciprocal encouragement of foreign trade activities here, particularly for Central and South American products.

A permanent exposition, already established in this city, will exploit American manufactured articles intended for export and foreign products seeking import.

Firms so far allied with the corporation include makers of textile goods, heating and lighting systems, chemicals, leather and rubber articles, and toys. The force of field agents will start this month for the regions mentioned, and will have authority to extend long credits to responsible foreign importers.

PLACED ON RESTRICTED LIST

War Board Recently Placed Graphite Crucibles on the List of Restricted Imports

The War Trade Board have, by a new ruling (W. T. B. R. 164), placed graphite crucibles upon the list of restricted imports. All outstanding licenses for the importation of graphite crucibles have been revoked as to ocean shipments after July 15, 1918, and no licenses for the importation of this commodity for shipment after that date will be granted for the rest of the calendar year.

Imports of graphite are already prohibited, the result of this restriction having been to develop an adequate supply of graphite within the country.

The Larkatone Music Co., of St. Louis, was incorporated in Missouri with a capital stock of \$5,000 for the purpose of dealing in pianos, talking machines, etc.

J. Stead & Co., Ltd.

Manor Needle Works

SHEFFIELD, ENGLAND

MANUFACTURERS OF

Talking Machine

Main Springs

Best Prices—Best Quality
Inquiries Solicited

LATEST PATENTS RELATING TO TALKING MACHINES AND RECORDS

WASHINGTON, D. C., August 8.—SUPPORT FOR HINGED COVERS.—Isaac B. Macomber, Portsmouth, R. I. Patent No. 1,265,930.

This invention relates to supports for hinged covers, and while particularly adapted for talking machine covers, is not so limited. The object of the invention is to provide means which operates to hold the cover open, and which is overcome by the weight of the cover when the latter is closed.

Figure 1 is a longitudinal sectional view of a talking machine cabinet with the present invention applied thereto. Fig. 2 is an enlarged section on line 2—2 of Fig. 1. Fig. 3 is a frag-

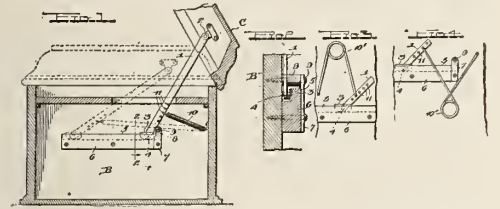

mentary side elevation showing a modified form of spring, and Fig. 4 is a similar view showing a further modified form of spring.

CORRECTION DEVICE FOR TALKING MACHINES.—Samuel Skelly, Philadelphia, Pa. Patent No. 1,266,065.

This invention relates to talking machines of the character used for dictation purposes and has for its special object the provision of simplified means for imparting information to the transcriber. Devices adapted to this purpose are known in the art. Thus it is known to provide a rotary disc operable by the traveling sound box to turn on its axis once during the travel of the sound box from one end to the other of the cylindrical record. This disc is provided with a scale and other characters, upon which, at any given point, a mark may be made which, by reference to the scale and the particular other character registering with the mark, will inform the transcriber that, at a corresponding point in the length of the record, something special must be done; for example, that a mistake has been made, or that a particular communication should be rushed, or that a certain number of carbon copies should be prepared.

This invention constitutes an improvement upon this type of correction and information device. One objection to the known devices is that their construction is more or less complicated. One of the objects of this invention is to simplify the construction so as to render the use of the device commercially practicable. Another and serious objection to the known devices is their lack of accuracy due to slight differences between the machine used for dictation and the machine used for transcribing. Ordinarily, as is well known, records are tran-

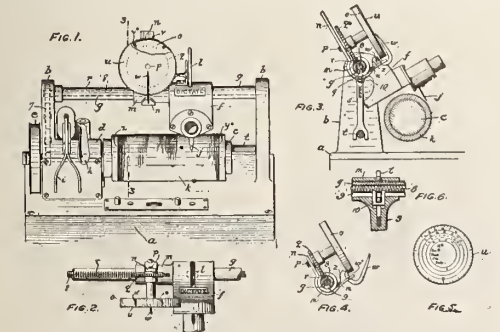

scribed from a different machine from that upon which they are dictated. The two machines, except in minor features, are essential duplicates. After a record is made on the first machine it is removed from the cylindrical holder thereof and slipped onto the cylindrical holder of the second machine, the indicator disc being also transferred from one machine to the other.

Due to the lack of exact correspondence in the dimensions of the two holders (which are tapered to facilitate the application of the record) or due to a failure on the part either of the dictator or transcriber to slip the record onto its holder to precisely the same extent, the indicator registers falsely, which is a source of confusion and error. One of the important objects of the invention is to obviate this difficulty. Another objection to the known device is that special discs (or in another type of dictating machine, special strips) must be provided, which adds to the equipment required. To avoid this, another object of this invention is to so construct the machine as to enable the cover of the box containing the record to be utilized as the indicator, thus dispensing entirely with the necessity of adding anything to the equipment required for operating machines devoid of any correction or information device.

Figure 1 is a front view of a portion of a talking machine embodying the invention. Fig. 2 is a partial top view of same. Fig. 3 is a cross sectional view on line 3—3 of Fig. 1. Fig. 4 is a section like Fig. 3 showing parts in another position. Fig. 5 is a detail face view of the indicator. Fig. 6 is a sectional view showing means by which the sound box is moved.

TONE ARM FOR TALKING MACHINE.—Charles J. Bousfield, Bay City, Mich., assignor to the Delphon Co., same place. Patent No. 1,266,096.

One object of the invention is to provide a tone arm so constructed that it may be used to reproduce sounds from either of the two types of records differing in the character of the sound undulations of the record groove. This is accomplished by providing a sound box which is arranged to assume either of two operative positions, in one of which the stylus of the sound box will co-operate with a record of the vertically undulating type to reproduce the recorded sounds, and in the other of which it will co-operate with a record of the laterally undulating type.

Another object resides in the provision of a tone arm of the nature stated, embodying among other characteristics means whereby the stylus assumes one playing position at all times, taking the groove of either the vertical undulating or lateral undulating grooved type of record on a direct line through the center of the tone arm

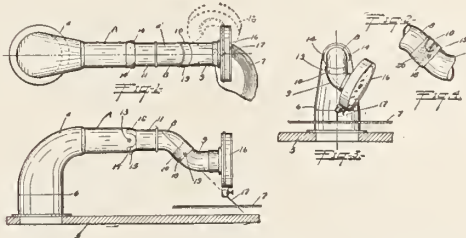

and always at the same angle with relation to the sound box, say, for instance, an angle of approximately forty-five degrees.

A still further object is to provide a talking machine having a tone arm constructed so that it may be adjusted to reproduce sounds from either the vertical undulating grooved type of records or the lateral undulating grooved type of records without adjusting or shifting the stylus from a normal playing position on a line extending through the center or longitudinal axis of the tone arm, or, in other words, providing a tone arm constructed whereby upon the substitution of one of the two types of records for the other, the stylus will assume the same playing position with relation to the tone arm when playing either record.

It is still further designed to provide a talking machine with a tone arm which may be adjusted to present the stylus of the sound box in the same playing position with relation to the sound box and the tone arm upon substitution of either of the two types of records referred

to for the other, without adjusting the stylus with relation to the sound box and without substituting one sound box for another and without adjusting an automatic stop device if the same be used on the machine.

Figure 1 is a top plan view of the invention, illustrating the reproducer in two different operative positions. Fig. 2 is a side elevation. Fig. 3 is a front elevation. Fig. 4 is a fragmentary detail view, partly in section, showing a swiveled connection between members of the tone arm.

TALKING MACHINE MECHANISM.—Archie E. Parnall, Chicago, Ill., assignor to Frank W. Williams, same place. Patent No. 1,266,307.

This invention relates to talking machine mechanism. One of its objects is to provide an improved construction whereby a machine can be easily and quickly changed for playing either a laterally undulating groove record or a hill and dale groove record, which will be simple in construction and effective.

Figure 1 is a vertical section of a talking machine showing the sound box in position for playing the laterally undulating groove record; Fig. 2 is a vertical axial section of a talking

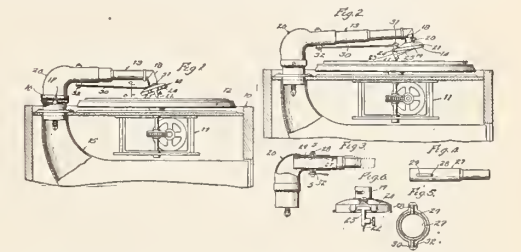

machine showing the sound box in position for playing a hill and dale groove record; Fig. 3 is a fragmentary side elevation of part of the tone arm, parts being in section to show the interior construction; Fig. 4 is a fragmentary view of part of one of the sections of the tone arm; Fig. 5 is a vertical section on the line 5—5 of Fig. 3; and Fig. 6 is a side elevation of the sound box.

AUTOMATIC RECORD SHIFTING MECHANISM FOR PHONOGRAPHS.—Edgar E. Brosius, Pittsburgh, Pa. Patent No. 1,266,767.

This invention has relation to mechanism for automatically shifting the records of a phonograph, and is designed to provide a simple mechanism of this character by means of which a phonograph may be caused to play a plurality of records in succession without the necessity for manual attention.

The invention also provides mechanism of this character which is readily adapted to existing machines. The invention is applicable to all phonographs of the disc record type.

Figure 1 is a plan view showing a phonograph equipped with the invention; Fig. 2 is a sectional elevation of the same; Fig. 3 is a section on the line III—III of Fig. 1 with the record-shifting arm swung to another position; Fig. 3^a is a detail sectional view; Figs. 4 and 5 are, respectively, a top and a front elevation of the slot plate; Fig. 6 is a sectional elevation showing the solenoid and its connections for raising the needle; Fig. 7 is a detail sectional view

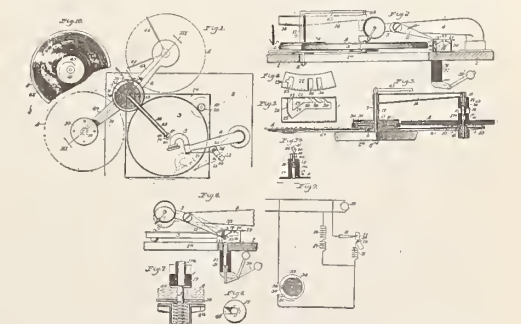

showing a portion of the record holder or magazine and the pick-up magnet; Fig. 8 is a bottom plan view of the lower pick-up magnet; Fig. 9 is a wiring diagram; Fig. 10 is a partial plan view of one of the records.

BALANCED HINGED TOP FOR CABINETS AND OTHER RECEPTACLES.—Thomas C. Linn, Jr., Salisbury, (Continued on page 104)

LATEST PATENTS RELATING TO TALKING MACHINES AND RECORDS—(Continued from page 103)

N. C., and John P. Butt, Jr., Gettysburg, Pa. Patent No. 1,266,834.

It is sometimes desirable to provide cabinets and other receptacles with a hinged or pivoted top which will remain fully open or closed or in any intermediate position without the aid of a manually operated prop. This is especially desirable in connection with graphophone or phonograph cabinet tops, where it is necessary to have the top remain in a raised position for the changing of records and needles, etc., particularly where the operator desires to use only one hand for performing these acts. Most of the devices for holding cabinet tops in a raised position with which we are familiar comprise a prop, hinged to the top, and having a slotted and notched free end which co-operates with a stop or catch on some part of the cabinet body, and in order to lower the top when such a prop is used, it is necessary to release the prop with one hand and lower the top with the other. This is sometimes inconvenient, because of one hand being occupied, as is often the case, with the manipulation of a graphophone, in holding the record which has just been removed from the machine.

The object of the invention is to eliminate the above-mentioned disadvantages, and to provide cabinet and other receptacle tops with a device which will support the top in any position without the use of a prop, such as referred to.

The invention consists in a hinged top for cabinets and other receptacles, provided with a weight-controlled lever mechanism so designed as to be capable of balancing the weight of the top to support it in fully open or closed position, or in any intermediate open position, or, when suitably adjusted, to cause the top to be automatically opened upon the release of a suitable detent, all as we will proceed now to explain and finally claim.

In the accompanying drawings, illustrating the invention, in the several figures of which like parts are similarly designated, Figure 1 is a vertical transverse section of a cabinet, such as used to contain a graphophone or phonograph, showing the top-operating device of the

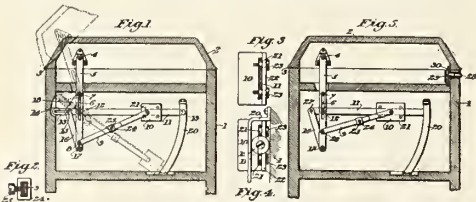

invention. Fig. 2 is a sectional elevation showing the weight adjusting means; Fig. 3 is an end view of the weight showing its roller mounting on the balance arm, and Fig. 4 is an end view of the balance arm showing its guide roller and track, all on a larger scale. Fig. 5 is a view similar to Fig. 1, showing a modification of the mechanism whereby the top may be automatically raised.

CONTINUOUS PHONOGRAPH, KINETOGRAPH, OR THE LIKE.—Orlando E. Kellum, Los Angeles, Cal. Patent No. 1,268,472.

This invention relates to the original making and reproduction of records, such as phonograph and kinetograph records, or any sound or visual or other like records; and the main object of this invention is the provision of means to make and reproduce a continuous record of indefinite length.

As applied to a phonograph, the invention embodies the following described typical elements: There are provided two distinct record driving devices adapted to drive separate records; and a constantly running motor (of any desired character) for normally driving either one or the other of the record drivers. There is a special device for initially starting either one or the other of the record drivers and for starting the corresponding record; and this starting device (preferably in the form of a motor adapted to be synchronously energized or controlled) is controlled so that it will bring

the next record up to even speed with the record being driven by the constantly running motor at a time when the preceding record is about finished. When the starting motor has brought the succeeding record up to normal speed, then the succeeding record is connected directly with the constantly running motor and may be driven synchronously with the preceding record for a short interval. The connection between the preceding record and the constantly running motor is then broken, and the succeeding record is then driven to its end. In the meantime the attendant takes the first record off the record driver and substitutes for it another record which will succeed the second record. The third record is brought into play in the same manner that the second one was brought into play, and so on indefinitely.

When the records are originally made they are made on a machine which is in all essentials a duplicate of the machine on which the records are finally reproduced. The starting of the new records, in either case, is controlled by the same control mechanism. Thus, whether the records are being made or reproduced, the preceding record will be given just so many revolutions before the succeeding record is started up and is thrown into driving relation with the constantly running motor; and the arrangements are such that, once the records have been taken under the control of the device, they will always in future match and synchronize with each other under the control of the device. In fact,

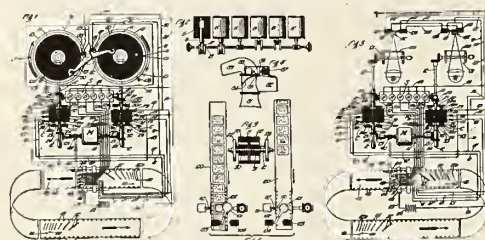

the only essential difference between a record making machine and a record reproducing machine, according to this invention, is the substitution of means for acting upon the record instead of means adapted to be operated by the record. The record herewith is meant to designate any form of visual, auditory or other record which is made at one time of events or conditions and is reproduced at another time.

Figure 1 is a diagram showing this invention as applied to a phonograph; Fig. 2 shows a preferred form of record starting motor; Fig. 3 shows a preferred form of connection means between the motor and the record drivers; Fig. 4 is a section taken on line 4—4 of Fig. 1; Fig. 5 is a diagram similar to that of Fig. 1, showing the invention applied to the kinetograph; Fig. 6 is an elevation taken as indicated by line 6—6 of Fig. 5.

PHONOGRAPH.—Samuel J. Hoexter, Kalamazoo, Mich. Patent No. 1,269,536.

This invention relates in general to phonograph construction for disc machines and has for its object to provide a more convenient construction of the phonograph housing and the mounting of the operating parts. The improvement resides essentially in the arrangement of a record support and reproducer arm so as to be movable in unison into and out of the main housing in a horizontal plane, while retaining the proper connection of the driving mechanism with the record support. To this end, the record support and reproducer arm are for example pivoted upon a vertical axis which is parallel with the turn table axis, but outside of the periphery of the turn table, the relation of the reproducer and the record therefore remaining unchanged throughout this movement from one position to the other. In this way the record receiving part is made accessible without having to raise the housing top or cover. The driving gear is connected from the turn table axis to the axis of the record support and reproducer arm through any suitable elements so that the relation of the power shaft to the driven part remains constant. The prin-

ciple of the invention may be carried out in a multiple form so that a plurality of reproducing outfits are associated within a single main housing, to permit the successive or simultaneous reproduction of a plurality of associated selections as for example in the case of operatic music exceeding the capacity of the single record, or in combining two or more reproductions simultaneously.

Figure 1 is a perspective view of a simple embodiment of the invention with the reproducing elements exposed for access. Fig. 2 is a similar view showing an example of the driving

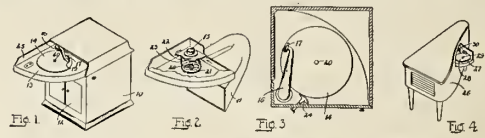

gear and the amplifier arrangement. Fig. 3 is a horizontal section of the device shown in Fig. 1, taken just beneath the cover. Fig. 4 is a perspective view of a somewhat different design of housing embodying the invention.

RADIAL SOUND AMPLIFIERS.—Carl F. W. Forssberg, Brooklyn, N. Y. Patent No. 1,270,610.

This invention relates to sound amplifiers in phonographs, and especially to that class wherein the cover of the phonograph serves as a main portion of the amplifier.

One advantage of this invention is to provide a phonograph with an amplifier which can be disassembled and stored in a recess in the pho-

graph, rendering the whole apparatus compact and portable.

Another advantage is to provide a phonograph having a storage space for records between the cover and the turntable.

Figure 1 is a perspective view of an apparatus embodying the present invention in a normal operative position. Fig. 2 is a rear view of amplifying tube 3. Fig. 3 is a side view of Fig. 1 in closed position, with portions of the sides removed to expose the interior.

Other patents issued but not illustrated and described are the following: Rotary Table for Sound Record Discs; Theo. Clifford Whiting, Philadelphia, Pa.; Patent No. 1,260,948. Talking Machine; Martin Nystrom, Chicago, Ill. (assigned to the Brunswick-Balke-Collender Co.); Patent No. 1,260,790. Phonograph Reproducer and Record Therefor; Charles D. Smith, San Jose, Cal. (assigned to Henry T. Welch); Patent No. 1,260,586. Stylus; Robert L. Gibson, Philadelphia, Pa.; Patent No. 1,260,365. Tone Modulator for Phonographs; Cheng Chih Kuo, Ithaca, N. Y.; Patent No. 1,260,001. Phonograph; Reinhold Thomas, Chicago, Ill.; Patent No. 1,259,681. Sound Box for Phonographs; John P. Westenhaver, Wheeling, W. Va.; Patent No. 1,259,815. Attachment for Talking Machines; Wm. A. Sharp, Des Moines, Ia.; Patent No. 1,259,916. Phonograph; Leslie McArthur, Kenilworth, Ill. (assigned to the Stewart Phonograph Corp.); Patent No. 1,259,645. Phonograph; George H. Underhill, Boston, Mass.; Patent No. 1,265,009.

REPAIRS

All Makes of Talking Machines Repaired Promptly and Efficiently

TALKING MACHINE REPAIR AND SALES CORPORATION

ANDREW H. DODIN, President
176 Sixth Avenue New York
TELEPHONE, CHELSEA 8437

RECORD BULLETINS FOR SEPTEMBER, 1918

VICTOR TALKING MACHINE CO.

POPULAR SONGS

- 18482 There's a Lump of Sugar Down in Dixie, Marion Harris 10
Story Book Ball, Billy Murray 10
When We Meet in the Sweet Bye and Bye, Sterling Trio 10
A Rainbow from the U. S. A., Peerless Quartet 10
18486 When Alexander Takes His Ragtime Band to France, Marion Harris 10
I'm Gonna Pin My Medal on the Girl I Left Behind, Peerless Quartet 10
18487 Garden of My Dreams, Charles Hart 10
Any Old Time At All, Helen Clark and Shannon Four 10
18488 Good-bye, Mother Machree, Harry Macdonough and Shannon Four 10
One For All and All For One, Helen Clark 10
18489 Oh, How I Hate to Get Up in the Morning, Arthur Fields 10
Oh! Frenchy, Arthur Fields 10
18477 Oh, Lady! Lady—Medley One-step, Waldorf-Astoria Dance Orchestra 10
Sinbad—Medley Fox-trot, Waldorf-Astoria Dance Orchestra 10
18483 Bluin' the Blues—Fox-trot, Original Dixieland Jazz Band 10
Sensation Rag—One-step, Original Dixieland Jazz Band 10
VOCAL AND INSTRUMENTAL RECORDS
45153 France, We Have Not Forgotten You, Lambert Murphy 10
I'll Pray for You, Olive Kline 10
35677 Gems from "The Rainbow Girl," Victor Light Opera Company 12
Gems from "Rock-a-bye-Baby," Victor Light Opera Company 12
18490 Old Dan Tucker, Victor Military Band 10
The White Cockade, Victor Military Band 10
18491 Green Mountain Volunteers, Victor Military Band 10
Speed the Plow, Victor Military Band 10
RED SEAL RECORDS
ENRICO CARUSO, Tenor—In English and French
87294 Over There (French words by Louis Delamarre), Geo. M. Cohan 10
EMILIO DE GOGORZA, Baritone
64786 Viking Song, Wright-Coleridge-Taylor 10
ELMAN STRING QUARTET
74576 Quartet in E Flat—Menuetto, Mozart 12
AMELITA GALLI-CURCI, Soprano—In Italian
74541 Barber of Seville—Uno voce poco fa (A Little Voice I Hear), Rossini 12
GIOVANNI MARTINELLI, Tenor—In Italian
74517 L'Ultima Canzone (The Last Song), F. Paolo Tosti 12
JOHN McCORMACK, Tenor
64785 Dear Old Pal of Mine, Harold Robe and Lieut. Gitz-Rice 10

COLUMBIA GRAPHOPHONE CO.

- 49339 Home Sweet Home (Payne-Bishop), Soprano solo, orch. accomp., Hulda Lashanska 12
49220 Il Trovatore. Il Balen Del Suo Sorriso. (In the Brightness of Her Glances; Tempest of the Heart) (Verdi). Baritone solo, orch. accomp., Riccardo Stracciari 12
A6057 Polish Dance (Kujawiak), Mazurka (Wienawski), Violin solo, Eddy Brown 12
Paraphrase on Paderewski's Minuet (Kreisler), Violin solo, Eddy Brown 12
A2572 My Possum Hunt (Unknown). Humorous monologue, unaccomp., Evan Davies 10
Mrs. Rastus Johnson at the Wedding (Unknown). Humorous monologue, unaccomp., Evan Davies 10
A6052 Funeral March of a Marionette (Gounod), Columbia Symphony Orchestra 12
Dragon Fly Mazurka (Strauss), Columbia Symphony Orchestra 12
A2450 Missouri Waltz and Little Alabama Coon. Hawaiian guitars and ukulele trio, Louise, Ferera and Greenus 10
A5838 Missouri Waltz and The Waltz We Love, Louise, Ferera and Greenus 12
A2358 Missouri Waltz (Hush-a-Bye, My Baby) and Sing Me Love's Lullaby, Campbell and Burr 10
DANCE RECORDS
A2576 Goulash (Hyde and Egan), Fox-trot, Jazirimba Orchestra 10
Jazzie Addie (A. Schubert), One-step, Jazirimba Orchestra 10
A2578 The Missouri Waltz (Knight, Logan and Eppel), Earl Fuller's Rector Novelty Orchestra 10
Smiles (Roberts), Medley fox-trot. Intro. "Mystery Moon" (Roberts), Earl Fuller's Rector Novelty Orchestra 10
A2577 They Were All Out of Step But Jim (Berlin), Medley fox-trot. Intro. (1) "When Alexander Takes His Ragtime Band to France" (Bryant, Hess and Leslie), (2) "Someone Else May Be There While I'm Gone" (Berlin), Piano solo, Mike Bernard 10
Blaze Away (Mike Bernard), One-step, Piano solo, Mike Bernard 10
A6058 If He Can Fight Like He Can Love (Good-night Germany) (Meyer), Medley one-step, Intro. (1) "We're All Going Calling on the Kaiser" (Brennan), (2) "I'd Like to See the Kaiser with a Lily in His Hand" (Lewis, Johnson, Frisch), Under the supervision of G. Hepburn Wilson, Prince's Band 12
Tackin' 'Em Down (Gumble), Medley fox-trot. Intro. (1) "When We Meet in the Sweet Bye and Bye" (Murphy), (2) "Wondrous Eyes of Araby" (Spencer), Under the supervision of G. Hepburn Wilson, Prince's Band 12
A6056 The Magic of Your Eyes (Penn), Waltz, Under the supervision of G. Hepburn Wilson, Prince's Band 12
Forget Me Not (McKee), Waltz, Under the supervision of G. Hepburn Wilson, Prince's Band 12
A6054 Good Morning, Mr. Zip-Zip-Zip (Lloyd), Medley fox-trot. Intro. "K-K-K-Katy" (O'Hara), Accordion trio, Marconi Brothers 12
A Little Bit of Sunshine (McDonald, Goodwin and Hanley), Medley one-step, Intro. (1) "Oh! Harry! Harry!" (Vincent and Pollack), (2) "You Can't Fool Around With a Lot of Little Girls" (Hanley and McDonald), Accordion trio, Marconi Brothers 12
A2584 The Captain of the Toy Brigade (McKenna), Male voices, orch. accomp., Sterling Trio 10
I Want to Be a Soldier Like My Dad (Morse), Tenor solo, orch. accomp., Robert Lewis 10
A2581 That Soothing Serenade (Was Just Written for Me) (De Costa), Tenor solo, orch. accomp., Robert Lewis 10
When You Feel a Little Longing in Your Heart (from "The Love Mill") (Francis), Male voices, orch. accomp., Columbia Stellar Quartet 10

- A2580 Your Lips Are No Man's Land But Mine (McCarrow and Morgan), Tenor duet, orch. accomp., Campbell and Burr 10
When I Send You a Picture of Berlin (Fay, Ryan and Dreyer), Baritone and male voices, orch. accomp., Arthur Fields and Peerless Quartet 10
A2569 We're All Going Calling on the Kaiser (Brennan), Baritone and male voices, orch. accomp., Arthur Fields and Peerless Quartet 10
Oh! Frenchy! (Conrad), Baritone solo, orch. accomp., Arthur Fields 10
A2570 Tackin' 'Em Down (Gumble), Character duet, orch. accomp., Van and Schenck 10
You'll Always Find a Lot of Sunshine in My Old Kentucky Home (Cowan and Brown), Character duet, orch. accomp., Van and Schenck 10
A2573 I Can't Let 'em Suffer (Creamer and Layton), Character duet, orch. accomp., Farber Sisters 10
I'm So Glad My Mamma Don't Know Where I'm At (Toosweet), Character duet, orch. accomp., Farber Sisters 10
A2582 After You've Gone (Creamer and Layton), Tenor duet, orch. accomp., Campbell and Burr 10
When We Meet in the Sweet Bye and Bye (Murphy), Male voices, orch. accomp., Sterling Trio 10
A2579 That Grand Old Gentleman, Uncle Sam (Edwards), Baritone solo, orch. accomp., Arthur Hall 10
I'm Just An Old Jay from the U. S. A. (H. Von Tilzer), Character song, orch. accomp., Byron G. Harlan 10
A2585 So Long, Sal, the Best of Friends Must Part (Lange) Tenor duet, orch. accomp., Campbell and Burr 10
Sweetness (Honeysuckle of Mine) (Leonard and Stern), Tenor duet, orch. accomp., Campbell and Burr 10
POPULAR HITS FROM THE MUSICAL SHOWS
A6055 Vocal Medley from "Going Up," Intro. (1) "Hip, Hooray," (2) "If You Look Into Her Eyes," (3) "Kiss Me," (4) "Going Up," (5) "Do It For Me," (6) "Tickle Toe," (7) "Down Up" (Hirsch), Orch. accomp., Columbia Light Opera Company 12
Vocal Medley from "The Rainbow Girl," Intro. (1) "You're the Finest of Them All," (2) "In a Month or Two," (3) "Beautiful Lady, Tell Me," (4) "My Rainbow Girl," (5) "I'll Think of You," (6) "Just You Alone" (Hirsch), Orch. accomp., Columbia Light Opera Company 12
A2575 Mrs. McLeod's Reel (Unknown), Violin solo, piano accomp., Don Richardson 10
The Devil's Dream Reel (Unknown), Violin solo, piano accomp., Don Richardson 10
A6053 General Pershing March (Vandersloot), Prince's band 12
Pasadena Day March (Vessella), Prince's band 12
A2574 Arahian Dreams (Maple), Hawaiian guitar, Hawaiian banjo and ukulele trio, Louise, Ferera and Greenus 10
Somewhere in Hawaii (MacMeekin), Hawaiian guitar, Hawaiian banjo and ukulele trio, Louise, Ferera and Greenus 10
A2571 When You and I Were Young, Maggie (Butterfield), Soprano solo, orch. accomp., Louise Robinson 10
Mighty Lak' a Rose (Nevin), Soprano solo, orch. accomp., Louise Robinson 10
A2583 Life in a Trench in Belgium—Part 3—(Fun in Flanders) (Rice), A series of trench records, Lt. Gitz-Rice of 1st Canadians and Henry Burr 10
Life in a Trench in Belgium—Part 4—(Fun in Flanders) (Rice), A series of trench records, Lt. Gitz-Rice of 1st Canadians and Henry Burr 10
A2568 Parted (Tosti), Tenor solo, orch. accomp., James Harrod 10
When the Corn is Waving, Annie Dear (Blamphin), Tenor solo, orch. accomp., James Harrod 10
E3910 Kosovo Waltz (waltz in memory of the battle of Kosovo), Tamburiza Serbian String Orchestra 10
Jefanovicevo Kolo (Jefanovicevo dance), Tamburiza Serbian String Orchestra 10
A3042 The Assembly March (Hager), Prince's Band 10
BattleShip Connecticut March (Fulton), Prince's Band 10
A3057 Children's Chorus, Seneca Indians 10
Funeral Chant, Seneca Indians 10
MUSIC OF HAWAII
Special Columbia Records
A2077 Kalahui's Hawaiian Medley of Hulahs, Geo. Kalahui's Hawaiians 10
Waiu Lulului, Louise, Ferera and Kainoa 10
A2016 Wailana Waltz (Drowsy Waters), Louise and Ferera 10
Hawaiian Medley, Louise and Ferera 10
A1861 Kaiwi Waltz, Palie Lua and David Kaili 10
Honolulu Rag, Palie Lua and David Kaili 10
A1814 My Old Kentucky Home, Louise and Ferera 10
Medley of Hawaiian Waltzes, Louise and Ferera 10
A2405 La Paloma, Louise, Ferera and Greenus 10
Valse Bleue, Louise, Ferera and Greenus 10
A1874 Kilima Waltz, Palie Lua and David Kaili 10
Hawaiian Hotel, Palie Lua and David Kaili 10
A1812 Hilo, Irene West Royal Hawaiian Troupe 10
Kohala March, Palie Lua and David Kaili 10
A1616 Aloha Oe, Toots Paka Hawaiian Co. 10
Hawaiian Medley, Toots Paka Hawaiian Co. 10
A2368 Smiles, Then Kisses (Waltz), Louise, Ferera and Greenus 10
Hawaiian Echoes (One-step), Louise, Ferera and Greenus 10
A1935 On the Beach of Waikiki, Louise and Ferera 10
Hapa Haole Hula Girl, Louise and Ferera 10

EDISON AMBEROL RECORDS

- CONCERT RECORDS
28288 It's a Mighty Good World After All (Geoffrey O'Hara), Baritone, orch. accomp., Arthur Middleton 10
28289 Marseillaise (French National Anthem) (Claude Joseph Rouget de Lisle), Baritone, orch. accomp., Thomas Chalmers and Chorus 10
REGULAR LIST
3547 (a) Ben Bolt (Nelson Kneass), (b) In the Gloaming (Annie E. Harrison), Cornet, Bohumir Kryl 10
3539 Bohemian Girl Selection (Michael W. Balfe), Creator and His Band 10
3549 Bring Me a Letter from My Old Home Town (Will R. Anderson), Tenor, orch. accomp., Reese Jones 10
3538 Bye an' Bye (arranged by H. T. Burleigh), Tenor, orch. accomp., Reed Miller and Chorus 10
3545 Bye and Bye (Harry Von Tilzer), Conversational duet, orch. accomp., Ada Jones and Billy Murray 10
3550 Camouflage (J. Bodewalt Lampe), One-step, for dancing, New York Military Band 10
3546 Colored Recruits, Vaudeville sketch with banjo, Billy Golden and Billy Heins 10

- 3534 Come Along Ma Honey (Down Upon the Swanee) (Harold Weeks), Contralto, orch. accomp., Helen Clark 10
3536 Dance of the Hours, Part 1—La Gioconda (Ponchielli), American Symphony Orchestra 10
3537 Dance of the Hours, Part 2—La Gioconda (Ponchielli), American Symphony Orchestra 10
3540 Day by Day the Manna Fell (arranged from L. M. Gottschalk), Mezzo-Contralto, orch. accomp., Nevada Van der Veer 10
3542 Derby Day in Dixie (Richard A. Whiting), Orch. accomp., Elaine Gordon 10
3544 Has Anybody Seen My Corinne (Lukie Johnson), Tenor, orch. accomp., Vernon Dalhart 10
3548 Homeward Bound (Geo. W. Meyer), Tenor, orch. accomp., George Wilton Ballard 10
3532 I'll Think of You (from "The Rainbow Girl") (Louis A. Hirsch), Soprano and Tenor, orch. accomp., Gladys Rice and Vernon Dalhart 10
3554 Jazbo Jazz (Earl Fuller), One-step, for dancing, Earl Fuller's Famous Jazz Band 10
3543 Put Me In My Little Bed (C. A. White), Soprano, orch. accomp., Gladys Rice and Chorus 10
3533 Rainbow Girl (Louis S. Hirsch), Fox-trot, Jazzarimba Band 10
3535 Sunshine of Your Smile (Lilian Ray), Tenor, orch. accomp., Vernon Dalhart 10
3552 Texas Fox-Frot (David W. Guion), for dancing, Jaudas' Society Orchestra 10
3541 Trumpeter's Carnival (F. H. Losey), March Militaire, New York Military Band 10
3551 We'll Do Our Sbare (While You're Over There) (Jack Egan), Mixed voices, orch. accomp., Harmony Four 10
3553 When Alexander Takes His Ragtime Band to France (Cliff Hess), Baritone, orch. accomp., Arthur Fields 10

EDISON RE-CREATIONS

- 80406 Just a Baby's Prayer at Twilight (M. K. Jerome), First soprano, second soprano and alto, Homestead Trio 10
Lorraine (My Beautiful Alsace-Lorraine) (Fred Fisher), Tenor and chorus, Vernon Dalhart 10
50472 'Round Her Neck She Wears a Yeller Ribbon (For Her Lover Who is Fur, Fur Away) (Geo. A. Norton), Byron G. Harlan and Chorus 10
Further It Is from Tipperary (Dudley-Godfrey-Burns), (From "Odds and Ends of 1917"), Billy Murray and Chorus 10
50473 I'll Take You Back to Italy (Irving Berlin) (from "Jack O' Lantern"), Conversational duet, Ada Jones and Billy Murray 10
Tickle Toe (Louis A. Hirsch) (from "Going Up"), Tenor and Chorus, Vernon Dalhart 10
50474 Dixie Volunteers (Leslie Ruby), Male voices, Premier Quartet 10
I'm Going to Follow the Boys (James V. Monaco), Conversational duet, Rachel Grant and Billy Murray 10
50475 Homeward Bound (Geo. W. Meyer), Tenor, George Wilton Ballard 10
I'll Come Back to You When It's All Over (Kerry Mills), Baritone and chorus, Edward Allen 10

PATHE FRERES PHONOGRAPH CO.

- 20411 Oh! Frenchy (Con Conrad), Boudini Bros., accordion accomp., Baritone, Arthur Fields 10
We're All Going Calling on the Kaiser (J. A. Brennan), Boudini Bros., accordion accomp., Baritone, Arthur Fields 10
20413 When I Send You a Picture of Berlin (Dreyer), Baritone, Arthur Fields 10
I'm Gonna Pin My Medal on the Girl I Left Behind (Irving Berlin), Baritone, Louis Winsch 10
20414 You're in Style When You're Wearing a Smile (E. Van Alstyne), Baritone, Louis Winsch 10
Blue Rose (Logan), Contralto, Helen Clark 10
20412 Three Pickaninnies (Brockman), Collins and Harlan 10
Thou Shalt Not Steal Thy Neighbor's Mule (C. Hess), Baritone, Arthur Collins 10
29214 Tinkle Inkle Inkle, from "Fancy Free" (A. Barratt), Contralto and Tenor, Ruth Lenox and Henry Burr 12
I Think You're Absolutely Wonderful, from "Oh, Look" (Harry Carroll), Baritone, Louis Winsch 12
40131 Favorite Army and Navy Songs (Medley No. 3), Lyric Vocal Quintet 12
An Old Time Cabaret (Medley No. 4), Lyric Vocal Quintet 12
NEW STANDARD BALLADS SUNG IN ENGLISH
20396 She Is Far from the Land (F. Lambert), Baritone, William Simmons 10
Forever Is a Long, Long Time (A. Von Tilzer), Baritone, Wm. Simmons 10
29212 Old Black Joe (Stephen C. Forster), Invincible Four 12
The Sweetest Story Ever Told (R. M. Stults), Tenor, Henry Burr 12
40133 Aloha Oe (Lihoukalani), Marie Morrissey, Contralto, and Invincible Four "Dreams" (Strelezki), Contralto, Marie Morrissey 12
20409 Cohen Phones the Real Estate Office (Bluff and Hayman) Comedian, Bernard Sternau 10
Cohen Calls His Tailor on the Phone (L. N. Leverich), Comedian, Bernard Sternau 10
20398 La Czarine (Mazurka Russe) (Louis Ganne), Broadway Saxophone Sextette 10
The Mosquito's Parade (H. Whitney), Broadway Saxophone Sextette 10
20415 Liberty Bell, intro.: Three Wonderful Letters from Home, Medley One-step (Mohr), Accordion duet, Peppino and Perry 10
I'll Take You Back to Little Italy, Intro.: When Alexander Takes His Ragtime Band to France, Fox-trot (Berlin), Accordion duet, Peppino and Perry 10
PATHE "DE LUXE" DANCE RECORDS
20416 Harry Fox Trot (Spot), American Republic Band 10
Johnny On the Spot, One-step (Roberts), American Republic Band 10
20417 Nona Waltz (Vandersloot), American Republic Band 10
Texas Fox Trot (D. Guion), American Republic Band 10
NEW OPERATIC VOCAL RECORDINGS
63025 Il Secreto Di Susanna (The Secret of Suzanne), in Italian (Wolf Ferari), Soprano, Claudia Muzio 12
La Forza Del Destino "Pace-Mio-Dio" in Italian (Verdi), Soprano, Claudia Muzio 12
ADDITIONAL ISSUE OF SINGLE PACE RECORDS
SUNG BY LUCIEN MURATORE
54012 "Paggiacci," "Vesti la Giubba" (On With the Play) in Italian (Leoncavallo), Tenor, Lucien Muratore 12
54003 "Werther," "Pourquoi me Reveiller" in French (Massenet), Tenor, Lucien Muratore 12
NEW INSTRUMENTAL RECORDS
20402 Irish Jigs—(Medley)—(1) McIntyre's Jig, (2) Carney's Fancy, (3) Donnbrook Fair, (Continued on page 106)

RECORD BULLETINS FOR SEPTEMBER

(Continued from page 105)

- Union pipes, piano accomp. Tom Ennis 10
Irish Reels—(Medley)—(1) McLeod's Reel. (2) Larry Reilly. Union pipes, piano accomp., Tom Ennis 10
29213 Parla Valse (Arditi). Whistling solo, Tom Ennis 10
Guida Girardini
Listen to the Mocking Bird (Winner). Whistling solo. Barneo Gardiner 12
40132 Reverie (Schumann). Violoncello solo, piano accomp. Joseph Hollman 12
Fleur d'Automme (Popper). Violoncello solo, piano accomp. Joseph Hollman 12
NEW BAND RECORDS
20379 Allies Patrol (March). (Arr. by H. Grant). Canadian Dominion Band 10
Canadian Patrol (March) (Arthur L. Lewellyn), Canadian Dominion Band 10
20400 Stradella Overture (Flowtow). Imperial Infantry Band 10
Tancredi Overture (Rossini). Imperial Infantry Band 10
20406 "Camp Fire" March (G. A. Carl). American Regimental Band 10
Our Boys March (Hugo Frey). American Regimental Band 10

SPECIAL NOTICE TO THE TRADE

The following three records appear in the regular September, 1918, Supplement and were previously announced in a letter to the trade, dated June 13, 1918, and for which special supplements were issued.

- 29211 His Wonderful Irish Brogue (Weston-Lee and Norworth). James A. Byrnes, piano accomp. Baritone. Jack Norworth 12
Do You Want Us to Lose the War? (Weston-Lee). James A. Byrnes, piano accomp. Baritone. Jack Norworth 12
29210 Fancy You Fancing Me, from "Odds and Ends of 1917" (Weston). James Byrnes, piano accomp. Baritone. Jack Norworth 12
The Further It Is From Tipperary, from "Odds and Ends of 1917" (Williams-Judge). James Byrnes, piano accomp. Baritone. Jack Norworth 12
29209 Moments of the Dance, from "Head Over Heels." One-step (Jerome Kern), American Republic Band 12
I Want to Learn to Dance. Intro.: The Girl I Can't Forget, from "The Kiss Burglar." Medley fox-trot (R. Hubbell), American Republic Band 12

All records in this list marked with a star () are for immediate release and sale.

EMERSON PHONOGRAPH CO.

(Sixty-five Cent Records)

- PATRIOTIC AND POPULAR SONG HITS
956 On the Level, You're a Little Devil (But I'll Soon Make an Angel of You) (Schwartz-Young). Baritone solo, orch. accomp. Eddie Nelson
Where Have You Been All These Years? (Mitchell-Cox-Kraus). Baritone solo, orch. accomp. Eddie Nelson
9454 Victory (Wilson-Barde-Kraus). Patriotic solo, orch. accomp. D. (Bud) Bernie
He's Got Those Big Blue Eyes Like You, Daddy Mine (Wilson-Dubin). Tenor solo, orch. accomp. Robert Bruce
953 Your Lips Are No Man's Lips But Mine (Empey-McCarron-Morgan). Tenor duet, orch. accomp. George Gordon and Robert Bruce
Paul Revere, Won't You Ride for Us Again? (Goodwin-Mohr). Vocal quartet, orch. accomp. George Gordon and Liberty Quartet
950 When I Send You a Picture of Berlin (Fay-Ryan-Dreyer). Patriotic solo, orch. accomp. D. (Bud) Bernie
Oh! Frenchy (Ehrlich-Conrad). Character Song, orch. accomp. Ben Linn
949 Oui, Oui, Marie (Wee, Wee, Marie) (Bryan-McCarthy-Fisher). Comic character song, orch. accomp. Ben Linn
Swat the Spy (Brice-Feiber). Patriotic character song, orch. accomp. Eddie Nelson
959 Indianola (Warren-Henry-Onivas). Indian novelty song, orch. accomp. George Beaver
Down in the Jungleland (Fields-Morse). Tenor and haritone duet, orch. accomp. Arthur Collins and Byron Harlan

LATEST DANCE AND INSTRUMENTAL RECORDS

- 960 Smiles (Callahan-Roberts). Fox-trot, Emerson Military Band
Since I Met You (Hubbell-Grant). One-step, Emerson Military Band
951 Oriental One-Step (Vincent Rose). Emerson Military Band
I Want to Learn to Dance (Hubbell-Miller). Fox-trot. Emerson Military Band
952 Jazz de Luxe (Earl Fuller). Fox-trot, Earl Fuller's Famous Jazz Band
Jazbo Jazz (Earl Fuller). One-step, Earl Fuller's Famous Jazz Band
958 Hello, Central, Give Me No Man's Land (Schwartz-Schultz). One-step, Emerson Military Band
Valse des Blondes (Ganne-Laurendeau), Emerson Military Band
957 Kee to Kee Rag (Platzman-Eastman). Fox-trot, banjo and accordion duet. Van Eps and Boudini
Down South (Myddeton). Descriptive Southern dance, banjo and accordion duet, Van Eps and Boudini
955 The Serbian Belovarska One-Step (conducted by Zerbes). Royal Serbian Orchestra
The Serbian Slobode Waltz (Liberty Waltz) (conducted by Zerbes). Royal Serbian Orchestra

SCHUBERT RECORDS

- Unless otherwise marked all vocal records are with orchestral accompaniment
All 10-inch records
PATRIOTIC SONG SELECTIONS
5157 Cheer Up, Liza, from "Cheer Up" (Hubbell), Baritone Solo
Melody Land, from "Cheer Up" (Hubbell), Baritone Solo
5149 Liberty Bell (Mohr). Male Quartet
Wait Till the Cows Come Home (Caryl) (Jack O'Lantern). Male Duet
5145 Keep the Home Fires Burning (Novello). Male Quartet
I May Be Gone for a Long Long Time (Von Tilzer). Baritone Solo
5192 It's a Long Way to Berlin (Platow). Tenor Solo
My Sweetie (Berlin). Tenor Solo
5182 I'm Writing to You, Sammy (Harriman). Tenor Solo
Never Forget to Write Home (Hanley). Tenor Solo
5200 Joan of Arc (Wells). Male Duet
I Don't Know Where I'm Going, But I'm on My Way (G. Fairman). Tenor Solo
POPULAR SONG SELECTIONS
5123 Round Her Neck She Wears a Yeller Ribbon (Norton). Male Duet

- There's Someone More Lonesome Than You (Von Tilzer). Male Duet
5183 That's What Ireland Means to Me (Hanley), Tenor Solo
Valley Rose (Lloyd). Tenor Solo
5176 Little Bit o' Honey (Jacobs-Bond). Tenor Solo
The Minstrel Boy (Moore), Irish National Song, Tenor Solo
5186 Absence Makes the Heart Grow Fonder (Dillea), Tenor Solo
A Baby's Prayer at Twilight (Jerome). Tenor Solo
5112 Aloha Oe (Farewell to Thee) (Lihoukalam), Soprano and Hawaiian accomp.
Kamawe (Shake Your Feet). Hawaiian
SACRED SELECTIONS
5193 The Church in the Wildwood (DeW. S. Pitts), Unaccomp. Male Quartet
My Faith Looks Up to Thee (Mason), Contralto, Organ accomp.
INSTRUMENTAL
5159 Patriotic Medley No. 1, intro.: The Red, White and Blue, The Girl I Left Behind Me, The Star Spangled Banner, Yankee Doodle, Concert Orchestra
Patriotic Medley No 2, intro.: Rally Round the Flag, Marching Through Georgia, Dixie, My Country 'Tis of Thee. Concert Orchestra
5170 Cavalleria Rusticana (Mascagni). Intermezzo, Symphony Orchestra
La Coquette (Onivas). Concert Orchestra
MARTIAL MUSIC
5128 Up the Street, March (Morse). Military Band
Liberty Loan March (Souza). Regimental Band
DANCE SELECTIONS THAT ARE POPULAR
5138 For the Freedom of the World (Zamecnik). One-step. Military Band
Smile and Show Your Dimple (Ruby). Intro.: Dixie Volunteers, Medley Fox-trot. Military Band
5140 Have You Seen the Ducks? (Goetz). Medley Fox-trot. Regimental Band
Paddle Addle (Snyder). Fox-trot. Regimental Band
5137 I'm Coming Back to You, Poor Butterfly (Donnelly-Hubbell). Fox-trot, intro.: Gee What a Wonderful Mate. Regimental Band
We're Going Over (Lange). One-step, intro.: There'll Be a Hot Time in the U. S. A., Regimental Band
5129 Long Boy (Hirschell-Walker). One-step, Military Band
Oh, You Daddy (Vincent). Fox-trot, Regimental Band
5172 Indianola (Onivas). Fox-trot. Regimental Band
Jack O'Lantern (Caldwell-Burnside-Caryl). Fox-trot. Military Band
5119 Hawaiian Hula Medley. Fox-trot. Hawaiian
The Glow Worm (Lencke). Hawaiian
5171 The Dream Waltz, adapted from The Tales of Hoffman (arr. by Klickman). Dance Orchestra
Send Me Away With a Smile (Glogan). One or Two-step. Dance Orchestra
5169 Yah-De-Dah (Kaufman). Fox-trot, Dance Orchestra
"Cutey" (Motzan). One or Two-step, Dance Orchestra
5202 Some Jazz Blues (Lake). Fox-trot Jazz, Dance Orchestra

- Valse Boston, Waltz. Dance Orchestra
5199 Till the Clouds Roll By (Kern). One-step, Military Band
Oh Johnny, Oh! (Ross-Olman). One-step, Dance Orchestra

EMERSON PHONOGRAPH CO.

- Thirty-five-Cent Records
PATRIOTIC AND POPULAR SONG HITS
7389 When We Meet in the Sweet Bye and Bye—Tenor duet, orch. accomp. George Gordon and Robert Bruce
Oh, Moon of the Summer Night—Vocal Quartet, orch. accomp. Liberty Quartet
7394 Your Lips Are No Man's Land But Mine—Tenor duet, orch. accomp. George Gordon and Robert Bruce
The Spirit of the U. S. A.—Patriotic solo, orch. accomp. Harry Evans
7393 Paul Revere, Won't You Ride For Us Again?—Vocal quartet, orch. accomp. George Gordon and Liberty Quartet
My Little Service Flag Has Seven Stars—Patriotic solo, orch. accomp. Edith King
7385 When Alexander Takes His Ragtime Band to France—Patriotic character song, orch. accomp. Eddie Nelson
Keep Jazzin' It Ras—Character Coon song, accomp. by piano, banjo and saxophone, Arthur Collins
7386 When I Send You a Picture of Berlin—Patriotic solo, orch. accomp. D. (Bud) Bernie
Swat the Spy—Patriotic character song, orch. accomp. Eddie Nelson
7387 We'll Do Our Share While You're Over There—Patriotic solo, orch. accomp. Harry Ellis
Oh! Frenchy—Character song, orch. accomp. Ben Linn
7390 Victory—Patriotic solo, orch. accomp. D. (Bud) Bernie
Mothers of France—Baritone solo, orch. accomp. Harry Evans
7388 He's Got Those Big Blue Eyes Like You, Daddy Mine—Tenor solo, orch. accomp. Robert Bruce
A Canoe Song—Tenor solo, orch. accomp. George Gordon
7396 Indianola—Indian novelty song, orch. accomp. George Beaver
Cheer Up, Tommy Atkins—Baritone solo, orch. accomp. Harry Evans
LATEST DANCE RECORDS
7392 Smiles (Callahan-Roberts). One-step, Emerson Military Band
7392 Down South (Myddeton). Descriptive Southern dance, banjo and accordion duet, Van Eps & Boudini
7395 Hello, Central, Give Me No Man's Land (Schwartz-Schultz). One-step, Emerson Military Band
Howdy—A Yankee "pep" step, Emerson Military Band
7391 Oriental One-step (Vincent Rose), Emerson Military Band
Valse Des Blondes (Ganne-Laurendeau), Emerson Military Band

COLUMBIA CO. STARTS CAMPAIGN ON PERSHING RECORD

Over Two Hundred Newspapers Will Carry Advertisements Calling Attention to the Record Made by General Pershing in France—Entire Issue of House Organ Devoted to This Record

The advertising department of the Columbia Graphophone Co., New York, has prepared a mammoth advertising campaign in behalf of the famous Pershing record, which is now in the

mand for this remarkable record, which was made under the supervision of the Nation's Forum.

According to present plans Columbia advertising in behalf of this record will include a five-column 280-line newspaper advertisement in more than two hundred newspapers throughout the United States. This advertising will aim to impress upon the public the fact that this Pershing record was recorded in the trenches of France, and that it gives every patriotic American an opportunity to include in their record library a message from the head of the American Expeditionary Forces abroad. This record by General Pershing has an enormous intrinsic value, and Columbia dealers predict that its sale will be limited only by the shipments from the Columbia factories.

PERSHING'S own voice speaks to you from the battlefields of France



The most remarkable Phonograph Record ever made—General Pershing's inspiring message on one side; Ambassador Gerard's address, "Loyalty" on the other

HISTORY on a phonograph record! At the height of the great offensive in Picardy, General Pershing sent his own voice across the water to America. An American Headquarters in France, this grim, iron-gray man spoke with crisp, soldierly brevity, into the horn of a recording instrument a message to the mothers, wives, fathers, children of the men who are fighting there with him on the shell-torn fields of France. Is there a home in all this great land that will not want to listen to the voice of our boys' commander?
A fac-simile of General Pershing's famous signature appears on every one of these records.
On the Other Side of this Record Ambassador Gerard speaks on "Loyalty"
Gerard—the man the Kaiser couldn't bluff; known to millions for his fearless Americanism, his splendid action in the face of emergency—
in his own ringing voice, tells what true loyalty is. He talks for four minutes and his words are history. To hear them, long years after the war, will bring again to your heart the surge and thrill of these wonderful days.
This historic record of the voices of Pershing and Gerard is the first of a series of records by the world's great leaders to be issued by the Nation's Forum as a weekly service. Each is a graphic, intimate bit of history—in the living voice of the man who is making that history today.
These records are made for the Nation's Forum by the Columbia Graphophone Company, with all of the rich clear tone and absolute fidelity to the original that distinguishes the musical records for which this Company is famous.
The Nation's Forum Records can be played upon any make of talking machine.
General Pershing's Record may be obtained here

(DEALER'S NAME HERE)

Ad Featuring Pershing Record

hands of Columbia dealers for sale. This advertising campaign will reach millions of music-lovers throughout the country, and will enable Columbia dealers to develop a tremendous de-

mand for this remarkable record, which was made under the supervision of the Nation's Forum.
According to present plans Columbia advertising in behalf of this record will include a five-column 280-line newspaper advertisement in more than two hundred newspapers throughout the United States. This advertising will aim to impress upon the public the fact that this Pershing record was recorded in the trenches of France, and that it gives every patriotic American an opportunity to include in their record library a message from the head of the American Expeditionary Forces abroad. This record by General Pershing has an enormous intrinsic value, and Columbia dealers predict that its sale will be limited only by the shipments from the Columbia factories.

In order that Columbia representatives may hitch up their local advertising with the national Columbia campaign, a series of two and three-column advertisements has been prepared. Matrices of these advertisements will be furnished to the dealers free of charge, and the accompanying illustration will give some idea of the effectiveness of this publicity.
The Nation's Forum, whose plans include a series of records by famous Americans, the first one of which is the record by General Pershing, will also lend their whole-hearted efforts to the proper introduction of the Pershing record. It is quite likely that public officials throughout the country will take due cognizance of the record, and the public will undoubtedly have their attention directed toward this record in many unusual ways.

For the benefit of Columbia dealers a special edition of the "Columbia Record," the official house organ of the Columbia Co., has just been issued, the contents of which are devoted entirely to the Pershing record. An artistic card in the company's Fifth avenue shop advises passersby along Fifth avenue that Columbia dealers everywhere have the Pershing record for sale, and many sales in the establishments of Columbia representatives will doubtless result.

Some Leading Jobbers of Talking Machines in America

1856 **WURLITZER** 1916

VICTOR
DISTRIBUTORS
VICTORS EXCLUSIVELY

We make a specialty of getting the order out on time—every time.

The Rudolph Wurlitzer Co.
CINCINNATI AND CHICAGO
Two points of supply; order from the nearer

TEST IT. 

OUR VICTOR
Record Service

has a reputation for efficiency.
Suppose you try it.

E. F. DROOP & SONS CO.
1300 G. STREET, WASHINGTON, D. C.
231 N. HOWARD STREET, BALTIMORE, MD



YAHR & LANGE DRUG CO.
MILWAUKEE, WIS.

Wholesale Distributors for

THE INSTRUMENT OF QUALITY
Sonora
CLEAR AS A BELL 

in Wisconsin
and Upper Michigan



Where Dealers May Secure

COLUMBIA

Product

STARR Phonographs
and **GENNETT Records**

Complete Stock and REAL Service

Crafts-Starr

PHONOGRAPH CO.

Factory Distributors
218-220 NORTH SECOND STREET, RICHMOND, VIRGINIA
Write for Dealers' Proposition

Smith, Kline & French Co.
PHILADELPHIA

Wholesale Distributors for

THE INSTRUMENT OF QUALITY
Sonora
CLEAR AS A BELL 

In PENNSYLVANIA, NEW JERSEY
and DELAWARE

Ready, Full Stocks, and Prompt Deliveries
from Convenient Shipping Centers
all over the United States.

Southern Victor Dealers
Largest Stock VICTROLAS and RECORDS.
Prompt Shipment and Low Freight Rates.

WALTER D. MOSES & CO.
Oldest Music House in Virginia or North Carolina.
RICHMOND, VA.

Distributors

C. L. Marshall & Co.
Wholesale Distributors
for Michigan

THE INSTRUMENT OF QUALITY
Sonora
CLEAR AS A BELL 

The Ohio Sales Company, Inc.
Wholesale Distributors
for Ohio
810-11 EMPIRE BLDG., DETROIT, MICH.

- Atlanta, Ga., Columbia Graphophone Co., 63 N. Pryor St.
- Baltimore, Md., Columbia Graphophone Co., 16 South Howard St.
- Boston, Columbia Graphophone Co., 137 Federal St.
- Buffalo, N. Y., Columbia Graphophone Co., 737 Main St.
- Chicago, Ill., Columbia Graphophone Co., 14 N. Michigan Ave.
- Cincinnati, O., Columbia Graphophone Co., 117-119 W. Fourth Ave.
- Cleveland, O., Columbia Graphophone Co., 1376 Euclid Ave.
- Dallas, Tex., Columbia Graphophone Co., 1011 Elm St.
- Denver, Colo., Columbia Stores Co., 1608 Glen-arm Place.
- Detroit, Mich., Columbia Graphophone Co., 401 Woodward Ave.
- Indianapolis, Ind., Columbia Graphophone Co., 44 N. Pennsylvania St.
- Kansas City, Mo., Columbia Graphophone Co., 1027 McGee St.
- Los Angeles, Cal., Columbia Graphophone Co., 745 S. Broadway.
- Minneapolis, Minn., Columbia Graphophone Co., 412-414 Nicollet Ave.
- New Haven, Conn., Columbia Graphophone Co., 206 Meadow St.
- New Orleans, La., Columbia Graphophone Co., 517-525 Canal St.
- New York City, Columbia Graphophone Co., 55 Warren St.
- Omaha, Neb., Schmoller & Mueller Piano Co.
- Philadelphia, Pa., Columbia Graphophone Co., 210 N. Broad St.
- Pittsburgh, Columbia Graphophone Co., 632-640 Duquesne Way.
- Portland, Me., Columbia Graphophone Co., 43 Exchange St.
- Portland, Ore., Columbia Graphophone Co., 429-431 Washington St.
- Salt Lake City, Utah, Columbia Stores Co., 221 South West Temple.
- San Francisco, Cal., Columbia Graphophone Co., 130-150 Sutter St.
- Seattle, Wash., Columbia Graphophone Co., 911 Western Ave.
- Spokane, Wash., Columbia Stores Co., 818 Sprague Ave.
- St. Louis, Mo., Columbia Graphophone Co., 1127 Pine St.
- Tampa, Fla., Tampa Hardware Co.

OLIVER DITSON COMPANY
BOSTON

Largest VICTOR Talking Machine Distributors East of Chicago.

Creators of "The Fastest Victor Service." Let us tell you more about our service.

W. J. DYER & BRO.
NORTHWESTERN DISTRIBUTORS
OF THE

VICTOR
Machines, Records and Supplies

 Shipped Promptly to all Points in the Northwest

ROUNTREE-CHERRY
RICHMOND VIRGINIA

Wholesale Distributors for

THE INSTRUMENT OF QUALITY
Sonora
CLEAR AS A BELL 

You  *above all must be satisfied!*

IN NORTH AND SOUTH CAROLINA

Headquarters for Canada:
Columbia Graphophone Co., 54-56 Wellington St., West, Toronto, Ont.

Victor Exclusively
EASTERN TALKING MACHINE CO.
177 Tremont Street, Boston
VICTOR DISTRIBUTORS

The Electric Supply & Equipment Co.
Exclusive Wholesale Distributors for
Southern New England

THE INSTRUMENT OF QUALITY
Sonora
CLEAR AS A BELL 

Complete stocks carried in Boston and Hartford

Little Bldg. 103 Allyn St.
BOSTON, MASS. HARTFORD, CONN.

Sherman, Clay & Co.

San Francisco, Los Angeles, Portland, Seattle, Spokane
PACIFIC COAST DISTRIBUTORS OF
VICTOR PRODUCTS

Executive Office
COLUMBIA GRAPHOPHONE CO.
Woolworth Building New York

The PERRY B. WHITSIT CO.
Distributors of
Victrolas and Victor Records
COLUMBUS, OHIO

THIS REFERS TO YOU, MR. DEALER

Every talking machine jobber in this country should be represented in this department, no matter what line he handles or where he is located. The cost is slight and the advantage is great. Be sure to have your card in this department of The Talking Machine World each month. It will pay you a big profit on the investment.

THE NEW EDISON



A Master Product of A Master Mind

JOBBER OF THE NEW EDISON, EDISON RE-CREATIONS,
THE NEW EDISON DIAMOND AMBEROLA AND BLUE AMBEROL RECORDS

CALIFORNIA
Los Angeles—Edison Phonographs, Ltd.
San Francisco—Edison Phonographs, Ltd.

COLORADO
Denver—Denver Dry Goods Co.

CONNECTICUT
New Haven—Pardee-Ellenberger Co., Inc.

GEORGIA
Atlanta—Phonographs, Inc.

ILLINOIS
Chicago—The Phonograph Co.
James I. Lyons. (Amberola only.)

INDIANA
Indianapolis—Kipp Phonograph Co.

IOWA
Des Moines—Harger & Blish.
Sioux City—Harger & Blish.

LOUISIANA
New Orleans—Diamond Music Co., Inc.

MASSACHUSETTS
Boston—Pardee-Ellenberger Co.

MICHIGAN
Detroit—Phonograph Co., of Detroit.

MINNESOTA
Minneapolis—Laurence H. Lucker.

MISSOURI
Kansas City—The Phonograph Co. of Kansas City.

MONTANA
Helena—Montana Phonograph Co.

NEBRASKA
Omaha—Shultz Bros.

NEW JERSEY
Paterson—James K. O'Dea (Amberola only).

NEW YORK
Albany—American Phonograph Co.

New York—The Phonograph Corp. of Manhattan.
Syracuse—Frank E. Bolway & Son, Inc.
W. D. Andrews Co. (Amberola only.)

Buffalo—W. D. & C. N. Andrews Co. (Amberola only.)

OHIO
Cincinnati—The Phonograph Co.
Cleveland—The Phonograph Co.

OREGON
Portland—Edison Phonographs, Ltd.

PENNSYLVANIA
Philadelphia—Girard Phonograph Co.
Pittsburgh—Buehn Phonograph Co.
Williamsport—W. A. Myers.

RHODE ISLAND
Providence—J. A. Foster Co. (Amberola only.)

TEXAS
Dallas—Texas-Oklahoma Phonograph Co.

UTAH
Ogden—Proudfit Sporting Goods Co.

VIRGINIA
Richmond—The C. B. Haynes Co., Inc.

WISCONSIN
Milwaukee—The Phonograph Co. of Milwaukee.

CANADA
Montreal—R. S. Williams & Sons Co., Ltd.
St. John—W. H. Thorne & Co., Ltd.
Toronto—R. S. Williams & Sons Co., Ltd.
Vancouver—Kent Piano Co., Ltd.
Winnipeg—R. S. Williams & Sons Co., Ltd.
Calgary—R. S. Williams & Sons Co., Ltd.

The TALKING MACHINE WORLD

For the
makers &
sellers of
talking
machines

Published Each Month by Edward Lyman Bill, Inc., at 373 Fourth Ave., New York, September 15, 1918

*The instrument by which
the value of all musical
instruments is measured*

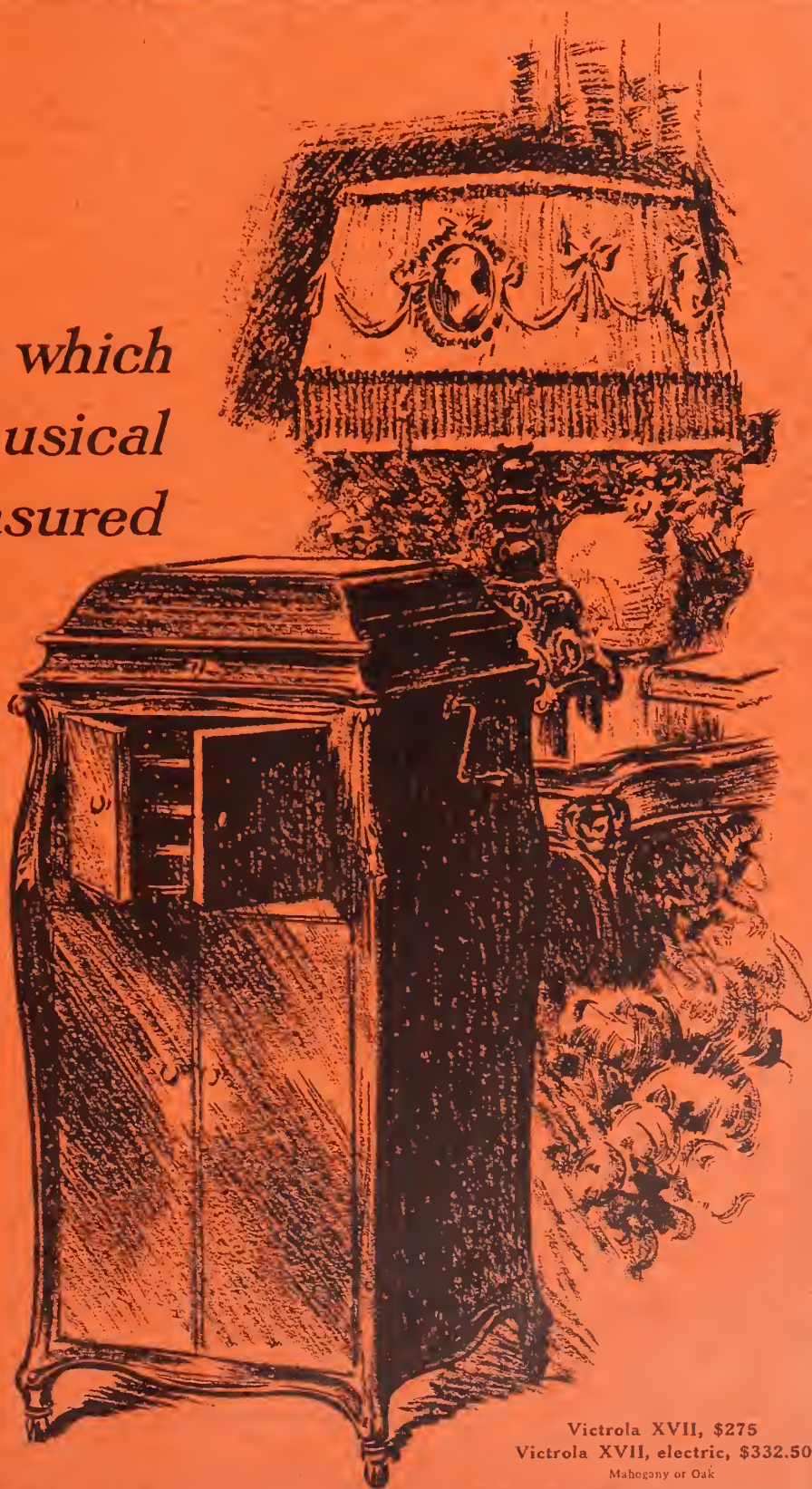

Victrola XVII, \$275
Victrola XVII, electric, \$332.50
Mahogany or Oak

THE INSTRUMENT OF QUALITY

Sonora

CLEAR AS A BELL



The Highest Class Talking Machine in the World

Maintains Its Supremacy Always

IN this era of costly materials, high-priced labor, and scarcity of skilled workers, there are temptations to substitute things not quite so good for materials and designs known to be *best*.

Sonora, however, maintains its quality through and through. You can rely on this. It is made up to meet lofty standards, *not* down to meet a low price.

For the best proof dissect a Sonora and compare its individual parts with those of other phonographs. The evidence in Sonora's favor is startling.

Handle the instrument that sells easily for *cash* because of the owner's *pride of possession*. Sonora is in popular favor, and firmly holds supremacy in the phonograph industry.

Write us today regarding the Sonora.

Period models now ready for delivery.

Sonora Phonograph Sales Company, Inc.

GEORGE E. BRIGHTSON, President

Executive Offices, 279 Broadway, New York

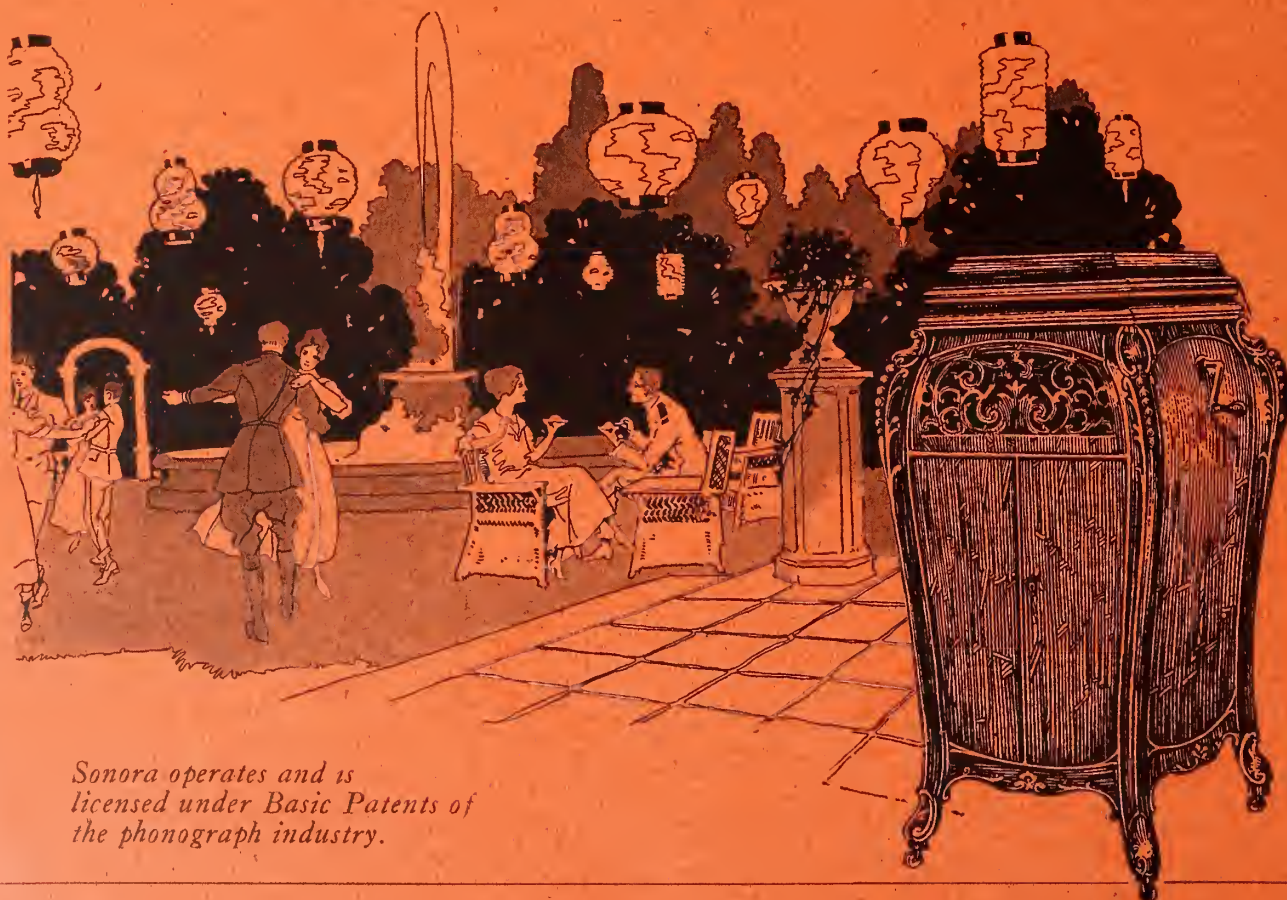

Sonora operates and is licensed under Basic Patents of the phonograph industry.

The Talking Machine World

Vol. 14. No. 9

New York, September 15, 1918

Price Twenty-five Cents

ENTHUSIASM A GREAT ASSET

The Real Secret of Salesmanship in the Talking Machine Field Is Locked Up in Energy Which Can Be Unlocked Only by Enthusiasm

Success in selling talking machines and records is up to the individual salesman. The man who fails will try to find excuses for his failure, but almost always the real reason for his failure is to be found in the fact that he did not put sufficient interest and energy into his work.

Before the ocean liner leaves her pier the agents know that the ship has plenty of energy stored in her bunkers—plenty of coal, the element that goes to make up propelling power. The ship has on board the potential energy to stem the tide of opposition.

The anchor, the searchlight, the wireless, the fog horn, are necessities—after the energy. Tact, politeness, personal appearance are necessities—after the energy.

Strength of will, measure of capacity, magnetic influence over men, the dynamic force of enthusiasm, are all the natural outcome of physical strength, good health—energy.

Men without energy are without enthusiasm. There are peddlers, there are undertakers, there are traveling men, and there are real salesmen. You can tell them by their enthusiasm.

The real secret of salesmanship is locked up in energy and unlocked by enthusiasm.

No adverse circumstances, no human power can hold back a man in selling, if he has force, courage. Give a man pluck, will power, a settled purpose, an overmastering energy, and barrels and barrels of enthusiasm, and he will sell talking machines, records, pins or pumpkins and make a success of it, too.

TALKING MACHINES ON THE PRAIRIE

Instance of How Instrument Has Brought Music Far Into the Interior of Canada

The manner in which the talking machine has penetrated far into the country districts and miles from the trade centers is indicated in the following item which appeared recently in the "Music in the Home Page" in a newspaper in Edmonton, Alta.:

A young woman called at the warerooms of a music dealer in Saskatoon to see some talking machine records. She mentioned that her home was two hundred miles from the railway, and that she had come to the city by motor car. Naturally enough the dealer began to show her some of the newer and more popular records. She was not particularly interested. "We have this one," was her invariable remark. After inquiry, the dealer learned that the family received every month the catalog of one of the leading companies, and purchased largely of the records by mail order.

When a family living on the prairie, two hundred miles from a railway, is in close touch with the trend of modern music, one may begin to realize the marvelous effect which this invention is bound to have on the general state of musical culture in Canada. It used to be that only the men and women living in the largest cities had the opportunity to hear the best music played by the best artists. Yet to-day "to earth's remotest bound" Mischa Elman, and Caruso, and McCormack, and Scotti, and the Chicago Symphony Orchestra are as well known as they are in New York or Toronto. The artists of to-morrow will find audiences all over the world, and will need to be of superb quality to hold their position against the new and wider criticism.

The Canadian Pacific Railroad has placed a Victrola and a large selection of records on each of its passenger steamships and has called attention to that fact in advertisements.

STADLMAIR NEW ASSOCIATION HEAD

President of C. Bruno & Son, Inc., Elected President of National Musical Merchandise Association Which Was Organized Recently

Henry Stadlmair, president of C. Bruno & Son, Inc., Victor wholesalers and musical merchandise importers and wholesalers, has been elected president of the National Musical Merchandise Association of the United States, an organization which was formed last month in New York. This association includes among its members all of the leading musical merchandise manufacturers and jobbers in this country, and it has been formed to promote the interests of this important branch of the musical instrument business and enable the different members of the industry to co-operate with one another along efficient and practical lines.

Mr. Stadlmair has for many years been an active figure in Victor talking machine circles, and his thorough knowledge of executive and



Henry Stadlmair

merchandising problems has won for him an enviable position in both the Victor and musical merchandise industries. His election as the first president of this new and important association, which has become a member of the Music Industries Chamber of Commerce, is a tribute to Mr. Stadlmair's indefatigable work to further the best interest of the industries with which he is associated.

HOW GODOWSKY WAS FEATURED

Decatur Dealers Gave Public an Idea of His Ability Through Columbia Records

Bachman Bros. & Martin Co., of Decatur, Ill., took splendid advantage of the recent appearance of Godowsky, the distinguished pianist, who was to play at University Auditorium of the School of Music, in that city, and sent out invitations to the public to hear the Columbia records of this artist's playing. A well-prepared newspaper campaign was conducted in this connection, as well as special window displays, with the result that not only were many Godowsky records sold, but the Bachman Bros. & Martin Co. secured an acquaintance with a number of people who, were it not for this concert, would not know the artist or the house as well as they know them now.

SUPPLIES NEEDED ENTERTAINMENT

Talking machines are becoming exceedingly popular throughout Indiana since the "dry" beer parlors have come into being. People want something more than dry beer; they want entertainment, hence talking machines fill the bill most pleasingly.

THE PHONE AS A SALES MEDIUM

Proof That the Phone Is a Profitable Sales Vehicle in Developing Talking Machine Trade if It Is Wisely and Intelligently Used

The World recently published an article on the value of the 'phone as a sales medium, and during the past month we have received no less than forty letters from dealers telling us that they have employed the 'phone in bringing their monthly lists of records to the attention of customers with splendid success. In one instance a dealer states that he got in touch by 'phone with several customers after he had received a new style of talking machine on the floor and made a sale without much difficulty. There is no question but that the 'phone is a valuable factor in sales development if intelligently and persistently utilized.

ORGANIZE \$100,000 COMPANY

Ohio Sales Co., Inc., Will Act as Sonora Distributors in the State of Ohio

DETROIT, MICH., September 4.—Charles L. Marshall & Co., 810 Empire Building, Michigan distributors for the Sonora phonograph, are closing a remarkably fine business, and Mr. Marshall stated recently that the demand for Sonora products in this territory is far outdistancing the supply. The company is endeavoring to co-operate with the Sonora representatives along practical and result-productive lines, and these efforts are meeting with gratifying success.

Mr. Marshall announced recently the incorporation of a \$100,000 company, to be known as the Ohio Sales Co., Inc., which will act as distributors for the Sonora line in the State of Ohio. According to present plans, this new company will carry warehouse stock in Canton and Dayton, O., and for the time being will have its executive offices at 810 Empire Building, in this city.

VALUABLE RECORD SALES HELP

Introduced by I. Davega, Jr., Inc., New York, Is Highly Spoken of By Dealers

I. Davega, Jr., Inc., 125 West 125th street, New York City, Victor distributors, are offering a sales help that is proving itself to be very valuable at this present time of record scarcity. It consists of a display rack for two records to be hung in the demonstration booth. The caption reads, "Play these records while you wait." The waiting customer in a demonstration booth upon this invitation is very often sold a record that he would not ordinarily buy from the reading of the title on a list. They report that many dealers are already using this new fixture to their great benefit. It has been found by them an important factor in moving records of which they have a large supply.

SOUTH AMERICAN DEMAND GROWS

WASHINGTON, D. C., September 4.—There is an enormous demand for talking machines and records at the present time in Argentina and Brazil, and large orders are being placed with American manufacturers which are not easy to fill owing to the shortage of ships. Many inquiries regarding these goods are reaching the local embassy, and, owing to the scarcity of talking machines, prices of these instruments in South America generally have appreciated more than 40 per cent. A recent report sent by the American consul says that a shipment of talking machines was forwarded from San Francisco, Cal., by Pacific Ocean Freight, landed at Valparaiso, Chile, and sent across the continent by trans-Andean railway to Rio de Janeiro and Buenos Ayres, arriving, over two months after shipment, at the latter points on July 20.

Why Quality Rather Than Price Should Govern the Salesman in Dealing with the Public

Of all the slogans which attract the interest and attention of clever salesmen, that one about "giving the public what it wants" is the most fascinating. It sounds so plausible, and is as plausible as it sounds. More than that, it really covers a deep truth of merchandising, a truth none the less true because little understood by the generality of superficial men, who neither think nor reason deeply.

Like all truths there are two aspects to this one. Or, to put it better, there are true and false aspects. The true aspect is the harder one to see rightly, and the false the easier to adopt; but in the former alone can the truth be seen.

If you stop to think of it, every piece of bad merchandising, every appeal to the lower side of public nature, feeling or desire, is invariably excused on the plea that the merchant does not exist to educate, but to supply wants; and that when he has given the public what the public wants his duty is done. But the fallacy lies in supposing that the public, in respect of most things offered for sale, has any special ideas at all. Now, if you argue consistently for the lower side of your industry, and because you can only see the poor side of everything, you conclude that talking machines can only be sold on price, you will undoubtedly find plenty of folks to come after you and buy them because they are cheap. Whence you may conclude that the public wants only the cheap; and that your duty is solely to give the public what you think the public wants.

But the man who reasons and acts in this way is playing with the facts. We often say to another, "You should not judge everybody else by yourself;" and the weakening effect on one's judgment of such a practice is evident. But it is just what we are all extremely likely to do in reasoning about business; and the effects upon our judgment are frequently disastrous. We do not know what the public wants if we imagine that the things we desire on our own lowest plane are identical with the things every one else desires.

It is not only in the cited case of bargain price inducements that the misjudgment of what the people want is common. Similar misjudgment commonly occurs in reference to public ideas of quality. It is a common assumption on the part of a man who likes noise and vulgarity to sup-

pose that all the world is noisy and vulgar. He takes you to a cabaret and supposes that he is showing you the life of the people. So it is with all that makes life worth living. The man who cares nothing for what is fine never can understand why perhaps others think differently. And he invariably is guilty of proclaiming that he speaks for the "plain people;" a particularly common and particularly nauseous hypocrisy, not the less so because it is often unconscious.

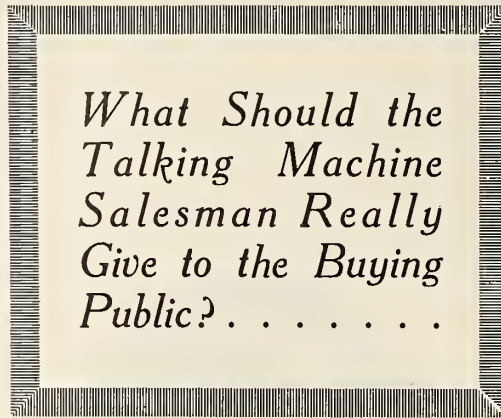

No! It is wholly wrong to suppose that popularity and success necessarily mean appealing only to the vulgar instinct of cheapness and an equally vulgar ignorance of quality. The great successes in the talking machine business, as in every other, have been made by the makers and sellers of quality goods. Look at the history, if you like, of just our own business; and see what it shows. The big permanent successes are made by the men who put quality first as their watchword and who adhere steadfastly to that watchword.

Consider for a moment. What does the public really want? In the first place, the very fact that a person comes to buy a talking machine is evidence, of itself, that a very strong desire exists on the part of that person for something which is not utilitarian, and which appeals to his higher instincts. Nobody buys a talking machine in quite the spirit manifested when one buys a bed, or a frying pan. Therefore, the presumption is always justified that the prospective purchaser, in his or her inmost heart, really desires something fine and beautiful, even if the question of price is apparently alarming.

See then what a foundation one has to build on. Comparatively few persons buy a talking machine because it is cheap. A person may buy a talking machine of low quality, at a corresponding price, because he or she feels unable to put more money into it; but that is not the same thing. That person would have bought a better one if he or she could have done so. Now, seeing that the ability or inability, in case of extended payments, is usually a matter of courage and desire combined, the salesman who does not work on this basis is neither clever nor efficient.

He is not clever because he really does not see the real state of the customer's mind. He is not efficient because he sells what is not so good instead of what is actually and positively good, when he might have encouraged the customer into taking the courageous step and so have satisfied both parties to the deal more perfectly in the end.

We need no argument, surely, to convince us that the man or woman who comes to buy a talking machine is in a state of mind predisposed to that which is excellent. Timidity, ignorance or fear may possibly produce a feeling of antagonism towards high-class goods or high-class prices; but this is a diseased condition which the salesman exists to remove. To play up to those feelings is precisely the thing not to do.

The real and right way of giving the public what it wants, in our business anyhow, is to realize that the prospect comes to the store with two ideas, one definite and the other indefinite. The indefinite one refers to the amount of money to be spent; the definite one is that a talking machine is desirable—that it should be good and must be reliable. In a word, the salesman who talks quality is talking about what the public really wants; and is preparing to give the public just that. Ninety-nine times in a hundred the prospects want just the very best they can buy and are more than half ready to go further than they would ever admit beforehand.

That is the true aspect of the question of "giving the public what it wants." It really wants quality; and the wise salesman is he who perceives this truth beneath the whole cloud of stupidities and fears, and is ready to uncover it for the benefit of his customer and himself as well.

THE FOUNDATION IS RIGHT

Conditions have changed and are changing, but the principles back of the DITSON SERVICE remain steadfast.

The Victor dealer is entitled to the best service we can give him, and he gets it without qualification and regardless of conditions.

There's a Human Touch to Ditson Service That is Particularly Valuable Just Now

Oliver Ditson Co.
BOSTON

Victor Exclusively

Chas. H. Ditson & Co.
NEW YORK

Victrola VI-A, \$32.50
Oak



Victrola IX-A, \$60
Mahogany or oak



Victrola XI-A, \$115
Mahogany or oak



Victor Supremacy

is firmly established on a basis of great things actually accomplished.

A supremacy that is growing greater every day—that insures ever-increasing prosperity to every Victor retailer.

Victor Talking Machine Co. Camden, N. J., U. S. A.

Berliner Gramophone Co., Montreal, Canadian Wholesalers

“Victrola” is the Registered Trade-mark of the Victor Talking Machine Company designating the products of this Company only.

Warning: The use of the word Victrola upon or in the promotion or sale of any other Talking Machine or Phonograph products is misleading and illegal.

Important Notice. Victor Records and Victor Machines are scientifically co-ordinated and synchronized in the processes of manufacture, and their use, one with the other, is absolutely essential to a perfect reproduction.

Victrola XVI, \$225
Victrola XVI, electric, \$282.50
Mahogany or oak



Victor Wholesalers

- Albany, N. Y.... Gately-Haire Co., Inc.
- Atlanta, Ga..... Elyea-Austell Co.
Phillips & Crew Piano Co.
- Austin, Tex..... The Talking Machine Co., of
Texas.
- Baltimore, Md.... Cohen & Hughes.
E. F. Droop & Sons Co.
H. R. Eisenbrandt Sons, Inc.
- Bangor, Me..... Andrews Music House Co.
- Birmingham, Ala. Talking Machine Co.
- Boston, Mass..... Oliver Ditson Co.
The Eastern Talking Machine
Co.
- Brooklyn, N. Y... American Talking Mch. Co.
G. T. Williams.
- Buffalo, N. Y..... W. D. & C. N. Andrews.
Neal, Clark & Neal Co.
- Burlington, Vt... American Phonograph Co.
- Butte, Mont..... Orton Bros.
- Chicago, Ill..... Lyon & Healy.
The Rudolph Wurlitzer Co.
Chicago Talking Machine Co.
- Cincinnati, O.... The Rudolph Wurlitzer Co.
- Cleveland, O..... The W. H. Buescher & Sons
Co.
- Columbus, O..... The Collister & Sayle Co.
The Eclipse Musical Co.
- Dallas, Tex..... The Perry B. Whitsit Co.
- Denver, Colo..... Sanger Bros.
The Hext Music Co.
The Knight-Campbell Music
Co.

- Des Moines, Ia.... Mickel Bros. Co.
- Detroit, Mich..... Grinnell Bros.
- Elmira, N. Y..... Elmira Arms Co.
- El Paso, Tex..... W. G. Walz Co.
- Honolulu, T. H.... Bergstrom Music Co., Ltd.
- Houston, Tex..... Thos. Goggan & Bro.
- Indianapolis, Ind. Stewart Talking Machine Co.
- Jacksonville, Fla. Florida Talking Machine Co.
- Kansas City, Mo.. J. W. Jenkins Sons Music Co.
Schmelzer Arms Co.
- Lincoln, Nebr.... Ross P. Curtice Co.
- Little Rock, Ark.. O. K. Houck Piano Co.
- Los Angeles, Cal. Sherman, Clay & Co.
- Memphis, Tenn... O. K. Houck Piano Co.
- Milwaukee, Wis... Badger Talking Machine Co.
- Minneapolis, Minn. Beckwith, O'Neill Co.
- Mobile, Ala..... Wm. H. Reynolds.
- Montreal, Can.... Berliner Gramophone Co.,
Ltd.
- Nashville, Tenn... O. K. Houck Piano Co.
- Newark, N. J..... Price Talking Machine Co.
- New Haven, Conn. The Horton-Gallo-Creamer Co.
- New Orleans, La... Philip Werlein, Ltd.
- New York, N. Y... Blackman Talking Mach. Co.
Emanuel Blout.
C. Bruno & Son, Inc.
I. Davega, Jr., Inc.
S. B. Davega Co.
Charles H. Ditson & Co.
Landy Bros., Inc.
New York Talking Mach. Co.
Ormes, Inc.
Silas E. Pearsall Co.

- Omaha, Nebr..... A. Hospe Co.
Mickel Bros. Co.
- Peoria, Ill..... Putnam-Page Co., Inc.
- Philadelphia, Pa. Louis Buehn Co., Inc.
C. J. Heppie.
The George D. Ornstein Co.
Penn Phonograph Co., Inc.
The Talking Machine Co.
H. A. Weymann & Son, Inc.
- Pittsburgh, Pa... W. F. Frederick Piano Co.
C. C. Mellor Co., Ltd.
Standard Talking Machine Co.
- Portland, Me..... Cressey & Allen, Inc.
- Portland, Ore.... Sherman, Clay & Co.
- Providence, R. I... J. Samuels & Bro., Inc.
- Richmond, Va.... The Corley Co., Inc.
W. D. Moses & Co.
- Rochester, N. Y... E. J. Chapman.
The Talking Machine Co.
- Salt Lake City, U. Consolidated Music Co.
The John Elliott Clark Co.
- San Antonio, Tex. Thos. Goggan & Bros.
- San Francisco, Cal. Sherman, Clay & Co.
- Seattle, Wash.... Sherman, Clay & Co.
- Sioux Falls, S. D.. Talking Machine Exchange.
- Spokane, Wash... Sherman, Clay & Co.
- St. Louis, Mo.... Koerber-Brenner Music Co.
- St. Paul, Minn.... W. J. Dyer & Bro.
- Syracuse, N. Y.... W. D. Andrews Co.
- Toledo, O..... The Whitney & Currier Co.
- Washington, D. C. Cohen & Hughes.
E. F. Droop & Sons Co.
Roht. C. Rogers Co.

AN IMPORTANT ACCESSORY—ALBUMS FOR FILING DISC RECORDS

The enormous demand for "National" Record Albums keeps pace with the ever increasing demand for machines and records, and our output capacity has been enlarged to meet the greater needed supply. Record Albums have proven themselves to be the best and most convenient, as well as economic, method of filing and keeping disc records.



MAKING THEIR SELECTION

Illustrating the daily actual usage of the Album, the most convenient and satisfactory record filing system extant.



THE ALBUM

soon pays for itself in time-saving and preserving records. The initial cost is really an investment which comes back fourfold.

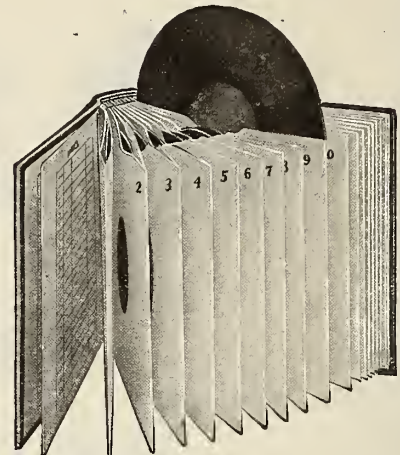

THE PERFECT PLAN

The pockets holding the records are substantially made from strong fibre stock, firmly joined together and bound in attractive covers.

A PLACE FOR EVERY RECORD AND EVERY RECORD IN ITS PLACE

Albums are an **Indispensable Requisite** in the talking machine business and wherever records are sold. An accessory that is necessary and worth while. Practical and handy. Save time and records. A **profitable adjunct** to the business. All owners of machines and records want Albums to file and preserve their records.

We manufacture disc Record Albums containing 12 pockets to fit cabinets of all sizes and styles. We also make Albums containing 17 pockets. With the indexes they are a complete system for filing all disc records.

For durability, finish and artistic design, our Albums are unsurpassed. We have unexcelled manufacturing facilities, and considering quality our prices are the lowest. Write us, giving quantity you may desire, and we will quote prices.

OUR ALBUMS ARE MADE TO CONTAIN VICTOR, COLUMBIA, EDISON, PATHÉ AND ALL OTHER DISC RECORDS

NATIONAL PUBLISHING CO. : 239 S. American Street : PHILADELPHIA, PA.

VOCAL LETTERS TO OUR SOLDIERS

Boggs & Buhl, Pittsburgh, Having Success With Department in Which Are Made Record-Messages Sent to Soldiers Overseas

PITTSBURGH, PA., September 5.—Boggs & Buhl, the large Northside department store, who are agents for the Victrola and Columbia Grafonola, were the first to introduce into Pittsburgh the plan for sending a vocal letter to soldiers overseas. This new department has been assigned to the talking machine section of the store, which is under the management of H. Wood. In making formal announcement of the new plan the firm made this statement:

"A private sound-proof room adjoining the Victrola department is at your disposal, similar to the rooms in which records are played. An attendant explains the simple method of operating the Dictaphone. The attendant withdraws, the door is shut, and as though the ears of your soldier were near you talk to him.

"In your presence the finished cylinder is sealed in an addressed container and the "talkie" is mailed. He gets this cylinder with his mail—so much warmer, so much more human than a written letter. He puts the cylinder on a Dictaphone (there will be one in his camp at Y. M. C. A. headquarters) and for four minutes he

sits beside you and hears the voice he loves. He can go back day after day and hear the voice over and over.

"And he sends you a 'talkie' in return, which you may bring to this department and hear, or which you may hear in any office or home where there is a Dictaphone. The cylinders are yours. You may keep them forever. In later life they will be the voices of your youth calling back across the years. We are glad and proud to be the first to offer the service of the Vocal Letter in Pittsburgh. Arrangements have been made for vocal letter service in all American camps."

J. D. MOORE WITH WERLEIN HOUSE

J. D. Moore, who has had long connection with the talking machine industry and who for a number of years was manager of the talking machine department of the Lion Dry Goods Co., of Toledo, O., was recently appointed manager of the talking machine department, both wholesale and retail, of Philip Werlein, Ltd., of New Orleans, La., the prominent Victor wholesalers.

Louis Bellaire has sold his talking machine business in Le Mars, Ia., to the Kehrberg-Schneider Co., but Mrs. Anna Bellaire will still continue to handle pianos at the old store.

MACARONI AND DATES AS LUXURIES

Musical Instrument Manufacturers Should Not Object to Having Their Products Classed With Food in National City Bank's List

If the foreign trade record showing imports of principal luxuries into this country during the years of 1918, 1917 and 1914 is to be accepted as a guide, manufacturers of musical instruments might have little cause for complaint about having their products classed as luxuries. Of course, the bank's list contains such articles as art works, beads, feathers, jewelry, automobiles, as well as musical instruments, and further includes macaroni, dates, figs, cheese and other foods. Personally, we should not care to explain to an Italian that macaroni was in the luxury class, or make a similar explanation to an Arab regarding dates. Perhaps bankers, being compelled to loan money at short interest, are forced to regard dates and macaroni as luxuries. It is indeed unfortunate.

MISS DOROTHY DOUGLASS MARRIED

Miss Dorothy Douglass, daughter of Leon F. Douglass, a director of the Victor Talking Machine Co. and also inventor of color motion picture appliances, was married late last month in San Rafael, Cal., to Eugene Trabucco, a son of Superior Judge J. J. Trabucco, of Mariposa County, who has qualified as a pilot in the Naval Aviation Camp in Ohio. The ceremony took place in the chapel of Dominican Convent at San Rafael, where the bride attended school. The wedding was a naval one, and the friends of the groom in the aviation service, wearing uniforms, were in attendance, and the entire affair made a very beautiful pageant. Following a brief honeymoon Mr. and Mrs. Trabucco left for New York, where the aviator rejoined his squadron.

The Talking Machine Co., of Rockford, has purchased the Victor department of the Dunlap store at Belvidere, Ill.



THE REGINAPHONE

A phonograph of the highest grade with many exclusive features. The new Regina Sound-box is the greatest improvement in talking machines in years, reproducing all hill and dale and lateral cut records equally well, and in a manner unsurpassed.

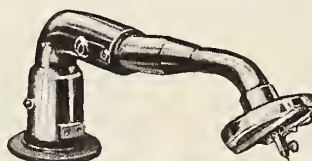

New Regina Sound-Box

Territory arrangements with active dealers. Send for particulars.

THE REGINA CO. 47 West 34th Street, NEW YORK
209 S. Wabash Ave., CHICAGO, ILL.

Manufacturers of the Regina Music Box and other musical instruments for over 25 years.

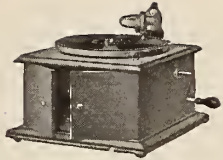

Victrola IV-A, \$22.50
Oak

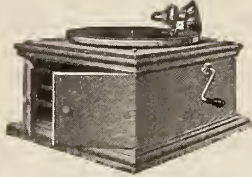

Victrola VI-A, \$32.50
Oak



Victrola VIII-A, \$50.
Oak



Victrola IX-A, \$60
Mahogany or oak

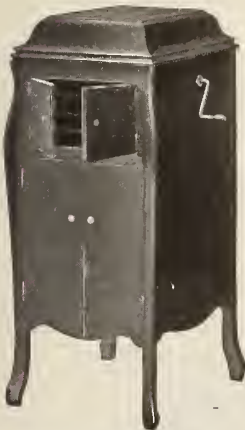

Victrola X-A, \$90
Mahogany or oak



Victrola XI-A, \$115
Mahogany or oak

Victor Supremacy is self-evident

It is the supremacy of achievement — of great things actually accomplished.

And it brings success to Victor retailers everywhere!



Victrola XIV, \$175
Mahogany or oak



Victrola XVI, \$225
Victrola XVI, electric, \$282.50
Mahogany or oak



Victrola XVII, \$275
Victrola XVII, electric, \$332.50
Mahogany or oak

Victor Talking Machine Co.

Camden, N. J., U. S. A.

Berliner Gramophone Co., Montreal, Canadian Wholesalers

"Victrola" is the Registered Trade-mark of the Victor Talking Machine Company designating the products of this Company only.

Warning: The use of the word Victrola upon or in the promotion or sale of any other Talking Machine or Phonograph products is misleading and illegal

Important Notice. Victor Records and Victor Machines are scientifically co-ordinated and synchronized in the processes of manufacture, and their use, one with the other, is absolutely essential to a perfect reproduction.



"HIS MASTER'S VOICE"
REG. U.S. PAT. OFF.

The TALKING MACHINE WORLD

For the makers & sellers of talking machines

PUBLISHED BY EDWARD LYMAN BILL, Inc.

President and Treasurer, C. L. Bill, 373 Fourth Ave., New York; Vice-President, J. B. Spillane, 373 Fourth Ave., New York; Second Vice-President, J. Raymond Bill, 373 Fourth Ave., New York; Assistant Treasurer, Wm. A. Low.

J. B. SPILLANE, Editor

J. RAYMOND BILL, Associate Editor

Trade Representatives: B. BRITAIN WILSON, L. M. ROBINSON, WILSON D. BUSH, C. CHACE, V. D. WALSH, E. B. MUNCH, L. E. BOWERS, A. J. NICKLIN

Boston: JOHN H. WILSON, 324 Washington Street

Chicago Office: E. P. VAN HARLINGEN, Republic Building, 209 South State Street. Telephone, Wabash 5774

London, Eng., Office: 2 Gresham Buildings, Basinghall St. W. LIONEL STURDY, Mgr. The Talking Machine World has regular correspondents located in all of the principal cities throughout America.

Published the 15th of every month at 373 Fourth Ave., New York.

SUBSCRIPTION (including postage): United States, Mexico, \$2.00 per Year; Canada, \$2.25; all other countries, \$3.75. Single copies, 25 cents.

ADVERTISEMENTS: \$4.50 per inch, single column, per insertion. On quarterly or yearly contracts a special discount is allowed. Advertising pages, \$125.00.

REMITTANCES should be made payable to Edward Lyman Bill, Inc., by check or Post Office Money Order.

NOTICE TO ADVERTISERS.—Advertising copy should reach this office by the first of each month. By following this rule clients will greatly facilitate work at the publication headquarters.

Long Distance Telephones—Numbers 5982-5983 Madison Sq.
Cable Address: "Elbill," New York.

NEW YORK, SEPTEMBER 15, 1918

THE death of August J. Timpe, treasurer of Edward Lyman Bill, Inc., publisher of The Talking Machine World, which is chronicled elsewhere in this issue, has brought keen sorrow to those who have been associated with him in the most intimate and closest relations for more than a decade, and who learned daily to appreciate his sterling character and well-balanced manhood.

Mr. Timpe was an earnest, unassuming and capable executive, who had made a close study of the music trade industry, and through his co-operation with the staff of The Talking Machine World assisted in winning for this publication a measure of the success which it has attained. His passing after a few days' illness was shocking in its suddenness, and a host of people who had intercourse with the business department of The Talking Machine World have written eulogistically of his very fine character, and of the pleasant relations they have always had with him. His death is a great loss to his family, to his friends and to The Talking Machine World.

THE value of organization in the talking machine trade has been very definitely demonstrated during the past month through the successful work accomplished by the War Industries Committee of the talking machine industry, which, in the person of H. L. Willson, vice-president and general manager of the Columbia Graphophone Co., presented facts so informatively and comprehensively before a sub-committee of the Ways and Means Committee, that the talking machine has now been placed in the "necessity" and not in the "luxury" class in wartime. The committee was so impressed with the information furnished that the official listing of this instrument as a "luxury" was changed, and the talking machine has been entered on the taxable list in the new Revenue Measure at 10 per cent, to be paid by the manufacturer, the same as pianos and other musical instruments, rather than in the 20 per cent. "luxury" class.

This means much, of course, for the industry, but it emphasizes more particularly what was pointed out in these columns last month, that it is high time for the industry to get together on a common footing—in a strong central organization—so that the many problems which confront it in these wartime days can be faced successfully.

The authorities in Washington do not care to deal with

individual manufacturers in any industry. They want to get in contact with an authoritative representative of the industry, and through him learn its exact needs and requirements, so that there is a minimum embarrassment to business and that it may continue as little unchanged as possible, conditional upon war requirements.

Of equal importance to the bearing of new legislation on our industry is the supply of steel and other essentials needed in the manufacture of talking machines. This subject has now been taken up by the War Industries Committee of the industry, and we feel confident that when the committee presents the full data to Washington, which will be based upon the information returned on the questionnaires sent out last month by the War Industries Committee, the needs of the industry will receive fair consideration, just as have the needs of allied industries.

We do not believe that the Government is desirous of harassing or destroying business. The successful conduct of the war is the first consideration, but, despite the tremendous and necessary demand for steel for important war purposes, we feel sure the Government will keep in mind the needs of the various industries, and work with them along co-operative, rather than destructive, lines, to the end that business of all kinds is perpetuated, for no country can keep going unless industry is maintained.

Mr. Willson is to be congratulated on the success achieved on his recent Washington visit, and his enlightenment of the members of the Ways and Means Committee proves afresh that it will be wise for the talking machine industry to have continually at the Capital a representative who knows the conditions in this industry, and who will be able to present its claims and needs to the consideration of those in authority.

Business men are facing serious conditions to-day, and it is a time when there should be a common understanding of ways and means. They can accomplish more for themselves and for the industry by forgetting petty jealousies and getting together, one and all, for the good of the trade. In every industry it is time for closer co-ordination between all factors to the end that the rights and interests of all are conserved. The time to act in this matter is now.

ALTHOUGH at the present time the second-hand business of talking machine dealers is of a negligible quantity, there is nevertheless a large number of machines taken in exchange for new and more elaborate models, or repossessed that they may be disposed of to more satisfactory customers and on better terms. It would, therefore, be well for members of the trade to keep in mind the ruling of the Federal Trade Commission that in advertising of used or second-hand machines it must be made plain that they have been used and are not new. In other words, the careless habit of offering standard machines at far less than list prices without stating that they had seen some wear and tear is not permissible. The Music Industries Better Business Bureau of Milwaukee is paying particular attention right now to all those who are violating the Federal Trade Commission's injunction, and there are enough problems to be faced at present without the talking machine dealer adding one more to the list. It must be said frankly that the legitimate talking machine dealers have not been offenders to any extent in this particular, but a word of caution nevertheless is not amiss.

THE subject of manufacturers fixing the price at which their products should be sold has been opened up afresh by a decision handed down recently in the New Jersey courts by Vice-Chancellor Lane, who held that the fixing of a standard price, if the article contained a notice of the conditions under which it might be sold by the retailer, was not a violation of the Sherman or Clayton acts. In this ruling he conditionally took issue with a decision of ex-Justice Hughes on price fixing and pointed out that "if the learned Justice meant that all restraints were void at common law, I think he was mistaken, but be that as it may, it is now well settled that restraints which are reasonable in the absence of the suit are valid. It is also well recognized that a person has a property interest in his trade name and good will, and will, even in the absence of a suit, be protected against injury to that trade name and good will. This right has in this State been, as above indicated, recognized by

statute." This suit was brought by R. H. Ingersoll & Bro., of watch fame, to restrain Hahne & Co., the well-known department store owners of Newark, N. J., from selling Ingersoll watches at less than the standard price without removing the trade name and manufacturers' guarantee.

THE big surprise of the month in trade circles is the announcement of the resignation of Louis F. Geissler as general manager of the Victor Talking Machine Co., an announcement that will be received with considerable regret by those who have been acquainted with Mr. Geissler's work on behalf of the industry. Although Mr. Geissler will relinquish his duties as general manager on January 1, 1919, it is gratifying to learn that he will still remain a member of the Board of Directors, and that the Victor Co. will, through that connection, be able to take advantage of his experience and wise judgment in matters relating to the policy of the company, and to the trade in general. During the thirteen years that Mr. Geissler has been connected with the Victor Co. he has seen the development of that institution to a point where it ranks among the great industries of the country.

Mr. Geissler was among the first to realize the tremendous possibilities of the talking machine as a leading factor in the musical world. While many others were regarding the instrument as a toy, or novelty, he had a realization of what it could accomplish in educating the public in matters musical and in bringing to them the voices of the great artists of the day. In other words, he saw in the talking machine a medium for giving to the masses music that ordinarily was reserved for the few. The result of this belief and the policy that developed therefrom is found in the fact that there is hardly an artist of wide reputation whose voice and playing is not found upon one or another of the various makes of records.

It is due to Mr. Geissler's general managership, and due in no small measure to his personal efforts, that the present Victor organization has developed. His mind was keen to grasp and his judgment was seldom faulty. With his knowledge of general trade conditions, therefore, one can accept with earnestness his prophecy made at the time of his resignation, to the effect that "after peace conditions are restored we shall all enjoy a more rapid development and expansion of business than ever before in the history of our industry."

THE further we go in our war program and the greater the demands made upon business in the prosecution of the war, the more it becomes evident that what is needed is a far better understanding between Governmental and business interests than exists at present, or has existed up to this time. This can only be brought about by an intelligent understanding of conditions.

The fact that a committee of the Chamber of Commerce of

the United States suggested a heavy tax on "Victrolas and various other mechanical musical instruments" as cited recently, shows which way the wind blows. It is not that Victrolas were mentioned, or the fact that they were selected as representative of the products of the entire industry—for it is a tribute to the Victor Co. advertising—but the phraseology does not reflect a definite knowledge on the part of those making the recommendation that should have been theirs before they took such a definite step. It is this habit of generalizing—this lack of definite knowledge—that has been in a way responsible for many of the inequalities in the existing War Revenue Law.

It has been claimed that the lawmakers in Washington are suspicious of business men, as a result of the efforts of the latter to receive special consideration in various war matters. It is not improbable that certain business interests have gone to Washington with the definite object of gaining special consideration for themselves and their industries, by any means possible. They have made exaggerated claims, presented doctored statements, and have created a very undesirable impression upon even conservative legislators, while giving to the radicals the opportunity to discredit all business interests.

Fortunately the great majority of business men are honest in their intentions, and have gone to Washington prepared to be fair and honest with the Government in the presentation of facts designed to bring about a proper consideration for their interests. It is now the duty of this majority to weed out the fakers and work to develop in Washington a confidence in what business men say and in the claims they make. With this confidence should come a willingness on the part of legislators to consult business men regarding the taxing or curtailment of their industry and base their findings upon the accurate and detailed information thus obtained. Even the most conscientious and fair-minded Congressman cannot be expected to be thoroughly familiar with every line of business in the country, and must depend for his information on outside sources.

The War Industries Board is working along the proper lines by demanding of industries that they appoint competent representatives to consult with the Board in Washington and likewise supply accurate statistics covering all factors of their trade, such as capital invested, and the labor and materials used and required. The result is that the War Industries Board can base its decisions upon an accurate knowledge of conditions in the various industries.

When the framers of the tax bill and other legislation learn to follow the same course; and show the same consideration for the opinions of men who have actual knowledge of the industrial situation, based upon experience, then it will be that much easier to carry on the burden of war. The burden has to be borne, we all know, but it can be so distributed as to cause a minimum of distress to industry or any one line of industry.



“RATIONS of Music” help to Win the War—both in the home trenches and the fighting trenches.

Go up in the woods for a week by yourself and you won't be gone a day before you'll realize that MUSIC IS ESSENTIAL. Alone in the woods is paradise compared to the muddy trenches.

That's why we should do all we can to get Records for the boys; why we should sell better music to the folks at home, and why among life's necessities must be included the Victrola.

Silas E. Pearsall Co.

Wholesale Distributors of Victrolas and Records

10 EAST 39th STREET

NEW YORK



For

**IMMEDIATE
DELIVERY**

A Limited Supply of
**BRILLIANTONE
STEEL NEEDLES**

*Orders Will Be Filled
Promptly As Received*

When this supply is exhausted, it will be impossible to tell when we will be in a position to again make Immediate Deliveries.

BRILLIANTONE STEEL NEEDLE CO. OF AMERICA INCORPORATED

Suite 655-657-659 Marbridge Building, Broadway at 34th Street

B. R. FORSTER, President

NEW YORK CITY



Artistic Window Displays That Arouse Public Interest in Talking Machines and Records

The value of the well-displayed talking machine window is becoming more fully recognized than ever before in the history of the trade. It has taken some time to awaken a great many dealers to the fact that the window is a factor of tremendous moment—a business developer, and a character indicator that makes a potential impress on the customer, prospective or actual.

It will be noticed that the successful stores in every line of business are those that give attention to the displays in their windows, concentrating original thought and effort in that direction.

While the leading talking machine companies supply material and ideas for window displays, yet the dealer with a limited display space need not rely alone upon help in this direction, for a simple background, well handled, aids in producing artistic and effective showings of records and talking machines if some ingenuity and taste are displayed in handling the material.

Recognized as the one great essential in window display advertising is the use of good judgment. The display man when in search of ideas for his displays must realize first, last and always what is best adapted for the special need of his particular store.

Oftentimes a setting is decided upon that is quite out of keeping with the line of merchandise carried by that store, or it may be quite beyond the ability of the display man to reproduce, so let us repeat that great care should be exercised in selecting ideas.

The simple background, well handled, is far better than a more elaborate one which is spoiled from lack of proper materials or poor workmanship. But, as O. Wallace Davis points out, do not think that simplicity in window displays will limit your artistic taste or handicap your designing of backgrounds. Quite the contrary will be your experience when you start to design an attractive display.

It takes a master to paint a canvas. It takes

ground than not enough. Too little color in a display is bad, but too much will prove to be infinitely worse.

Never lose sight of the fact that you are showing the public merchandise and not pretty backgrounds, and for the average store you will not go far astray from their policy of doing business.

Of course, there are exceptions to this, but usually they are of such a class that they em-



Attractive Window Prepared by Cohen & Hughes, Washington, D. C., in Which Victor Specialties Are Featured

an Alma Gluck to sing a plain plantation song and start the whole world singing "Carry Me Back to Old Virginny."

A simple scene, a simple song—yet in the hands of an artist they make the world sit up and take notice.

So with the window, simple effects well handled, rightly used settings, and careful attention to the fitness of things, will give results not to be attained by trying after things beyond our proper sphere.

More displays are spoiled by too much back-

ploy artists who make a specialty of this kind of work.

Never lose the opportunity in showing goods to emphasize any special features that may be associated with the article. A few articles with some special feature well worked out are worth more than a window full of the same article without the demonstration.

Try to put the punch in a display that is always to be found in a well-illustrated advertisement. Such things interest the public far more than a worded argument on cardboard.

ADVANCE IN EDISON PRICES

New Prices, Effective September 1, Are Formally Announced to the Jobbing Trade

Thomas A. Edison, Inc., in a bulletin to its jobbers dated August 15, makes formal announcement of the increase in Edison prices which the dealers last June at the annual Edison dealers' convention were told would be put into effect on or before September 1. The new list prices are subject to the same discounts as heretofore. The following table of comparisons shows the previous list prices and the new prices:

Edison Amberola Phonographs		
	Old Prices	New Prices
Amberola 30	\$35.00	\$ 41.00
Amberola 50	58.00	68.00
Amberola 75	82.50	100.00
Disc Phonographs		
	Old Prices	New Prices
A-100	\$106.00	\$120.00
C-150	160.00	175.00
C-200	200.00	220.00
C-250	265.00	285.00
W-250	265.00	285.00
B-275	290.00	300.00

For the time being, at least, there will be no change in the list prices of Blue Amberol records or disc re-creations. However, the discounts are being changed to conform with the discounts on the disc instruments.

The bulletin to jobbers concludes with the significant statement that should additional taxes be imposed, further changes in Edison prices will be necessary. It is believed prob-

able by the trade that any additional tax that may be levied will not be incorporated in the list prices, but will be handled as a separate item to be charged separately.

The Edison Co. did not advance its prices without exhaustive investigation of its present cost of manufacture. The first survey of costs was not satisfactory and a resurvey was made. The officials of the company have taken an uncompromising stand against any unnecessary increase in prices, and it is the opinion of William Maxwell, vice-president of the company, that the new prices will yield a smaller percentage of profit than the prices in effect last year.

"We hear on all sides," Mr. Maxwell remarked, "that the buying public is reconciled to paying high prices and that a few dollars more or less will make no difference. That may be true, but we don't intend to ask a penny more for our goods than we have to ask and whatever we lose in profits that we might have gained by boosting our prices unduly I think will be compensated by the confidence of our trade."

IOWA DEALERS POSTPONE MEETING

DES MOINES, IA., August 28.—The annual convention of the Iowa Victor Dealers' Association scheduled to be held in this city this week has been postponed until later in the year, owing to existing conditions. The executive committee will announce new dates when a decision is arrived at.

REMODEL QUARTERS IN VANCOUVER

VANCOUVER, B. C., September 1.—The Kent Piano Co., Ltd., have recently redecorated their Edison Salon and show windows. The scheme is pale gray tapestry and panels. The ten days' postal strike affected wholesale business, this firm being Edison jobbers, but the firm report retail trade quite up to expectations.

A new talking machine department has been installed in the H. Hertz store, Terre Haute, Ind., where the Victor line is handled exclusively.

Talking Machine Hardware

We manufacture hardware for all styles of cabinets

- | | | |
|--------------|-------------------|-------------|
| Lid Supports | Door Catches | Sockets |
| Needle Cups | Sliding Casters | Tone Rods |
| Needle Rests | Continuous Hinges | Knobs, etc. |

BEST QUALITY

LOWEST PRICES

WEBER-KNAPP COMPANY

Jamestown, N. Y.

Edison Message No. 26

WHEN Thomas A. Edison said "The Marseillaise is worth a million men to France" he paid the highest possible tribute to the value and importance of music in wartime.

This picturesque phrase that now is ringing over the country carries a message to every Edison dealer. Music is necessary to the morale of our armies, but it is equally vital to the mental welfare of those at home.

The Edison dealer who helps his community obtain the music it desires and needs is doing the country a service as well as himself.

THOMAS A. EDISON, Inc.

Orange, N. J.



THIS TRADE MARK
ON EVERY EDISON PHONOGRAPH
Thomas A Edison

A word to the wise dealers—make a trade-in proposition on Vacation Model Grafonolas.

**Columbia Graphophone Co.
NEW YORK**



41ST ANNIVERSARY OF THE EDIPHONE

Occasion Marked by a Sales Convention With Delegates From All Parts of the Country—Gold Ediphone Presented to Thos. A. Edison

An interesting event recently at the plant of Thomas A. Edison, Inc., Orange, N. J., was the

"I believe that my work is growing more important every day, and that it is my duty to do everything in my power to develop myself physically, mentally and spiritually so that I may become a Master Salesman and thus take my place among the Master Servants of my times.

"I believe that this organization, in convention

assembled, in bringing together men who are giving their best efforts to the bettering of American business, has helped me to see more clearly than ever before my duty to myself, my employers, my company, and to the nation of which I am a citizen, and I want to dedicate myself to the task of using all that I have learned and all that I shall learn in the work of placing the Ediphone system wherever it will best serve my fellow men.

"I believe that in Thomas A. Edison, the head of the business institution I represent, whose long life has been a life of service, the value of which no man of his own times can correctly estimate, I have before me an example that will sustain and strengthen me as I face obstacles, hardships and discouragements, and that the thought of what he has done for me will send me forward with courage in my heart and steel in my purpose to give, as he has always given, the best that is in me to make the world a better place in which to live and work.

"With this determination, I am returning to my home city and with this purpose dominating my life I shall work faithfully and efficiently during all the days of the coming year. This is the ideal toward which I am working."

VICTOR TRAVELER TRANSFERRED

B. M. Walthall, formerly Victor representative in the Pacific Coast district, has been transferred to the East and is now traveling for the company in western Massachusetts.



Gathering at Orange, N. J., That Celebrated the 41st Anniversary of the Invention of the Ediphone

celebration of the forty-first anniversary of the invention of the Ediphone, which was made the occasion of a convention of the sales forces of that division of the company. Delegates came from practically every State from Maine to California, and in addition to discussing various sales problems, they presented Thomas A. Edison with a gold Ediphone as a mark of their appreciation of his work in developing the instrument to its present point of perfection.

The convention opened on Monday, and in addition to the business sessions the delegates were entertained at luncheon at the Essex County Country Club, were conducted on a tour of the factory, were guests of the company at a performance of the "Ziegfeld Follies," and finally were given an elaborate banquet at Murray's on the final evening of the convention.

About 100 Ediphone representatives attended the convention, and during the business sessions found many matters worthy of earnest discussion, particularly regarding selling plans for the future. In the course of the convention those assembled adopted unanimously the "Edison Salesman's Creed," as follows:

"If the Government does not need me Over There, I believe that in selling the Ediphone I am rendering a service to my country because I am helping the nation to do more and better work at the cost of less time, money and energy; that everything that saves time, money and energy helps to win the war, and that to win the war is the one supreme task to which I must dedicate my life.



In September The Farmer Reaps His Harvest—the reward for months of honest toil. Dealers who handle the

SCHUBERT PHONOGRAPH

Reap a Harvest all the year; Fall and Winter months are particularly good, but you must have a Schubert Machine on your floor with which to make good. It's time now to get your order in. Let a Schubert make your harvest worth reaping. It will if you become a dealer to-day.

SIX MODELS \$60.00 UP

SCHUBERT RECORDS

The BELL TALKING MACHINE CORPORATION

Offices and Show Rooms:
44 West 37th Street, New York

Export Department, 498-504 Broadway, New York, N. Y., U. S. A.
Smith-Woodward Piano Co., 1018 Capitol Ave., Houston, Tex., Local Distributor

Factory:
85 Southern Boulevard, Bronx, New York





A \$30 investment starts you with complete, up-to-date list of Popular, Vocal and Instrumental selections; 20 to 30 new selections monthly; 10-Inch Double Disc. Write for details.



A New Interest

If you could bring about a situation that would actually improve the tone of your talking machine, and at the same time eliminate that annoying scratch, causing you to settle back in your easy chair, with something like "Oh, how fine" or "Oh, what a relief," wouldn't you hasten to do it? The "B and H" Fibre Needle will produce just such results. We sell them. Try them.

(Name of firm)

Come In and Ask Us

To reproduce your favorite record, one which you have at home, with the B and H Fibre Needle. You will note a distinct difference—the scratch will be prominently noticeable, *because of its absence*, and an improved clear tone because of its *presence*. We will be glad to point out the economy in their use, demonstrating the use of the same needle for several records, and how they may be repointed and used again.

(Name of firm)

The "Aye" of the Needle

There's the needle of the compass, the needle of the pines, the needles of commerce, and then there's that other needle through the eye of which, it is said, it would be a difficult matter for a camel to pass. A vote on the question of talking machine needles—as to the clearest and most satisfactory tone, freedom from unpleasant noise, non-injury of records and economy of use—would undoubtedly result in a large majority of "ayes" in favor of the "B and H" Fibre Needle. Come in and hear it.

(Name of firm)

Has Made Good

The "B and H" Fibre Needle has made good in every way. Artistically, because noiseless and because of the consequent clear and natural tone.

Economically, because of the positive non-injury to the record, and because each needle may be used several times, and then, by using a simple inexpensive little device, may be repointed several times, and each time with an improved tone. You'll be pleased with it. Drop in and hear it.

(Name of firm)



Mr. Dealer

*Here Is A Suggestion
To You From Us*

Supplemented by Eight Suggestions which we recommend you to submit to the owners of Talking Machines in your bailiwick, through the medium of your home newspapers.

All This

in a well-directed campaign for increased sales of records;

For, Be It Known

that the pleasure of listening to records reproduced with the

"B and H" Fibre Needle

without exasperating, rasping noises, and in beautifully clear, natural tones, will in many instances result in the determination to increase the home repertoire of selections.

The panels on the right and left contain eight reading notices for insertion in your home paper, one in each issue, whether daily or weekly, the cost of which will be merely nominal. Persisted in, such a campaign of publicity should increase your record profits and benefit your customers as well. Try it!

**"B and H" Fibre
Mfg. Co.**

**33-35 W. Kinzie Street
CHICAGO**



Needles! Needles! Needles!

It is needless to say that every good housewife knows all about sewing machine needles, but we wonder if she knows all about "B and H" Fibre talking machine needles. They reproduce records with a beautifully clear tone, eliminating entirely the irritating scratching sound, can be used for several records, then re-pointed and used again to the very best advantage, and that without injury to the record. Try them for satisfaction.

(Name of firm)

The Connecting Link

The modest talking machine needle, while the smallest individual part or accessory used in the instrument, is, nevertheless, a most essential part. In fact, without it there could be no melody, no harmony. It is, therefore, the all-important connecting link between the inanimate record and the living, pulsing, audible realization of the hieroglyphics indented thereon. That the realization may be the most pleasing and gratifying, the "B and H" Fibre Needle should be used as the connecting link. Give it a trial.

(Name of firm)

There'll Come a Time

Whether you are the happy possessor of a good talking machine, or living in anticipation of ownership, there'll come a time when you will try the "B and H" Fibre Needle. You will then get the best and most satisfactory results from the reproduction of your records.

It would be a good plan to adopt them at once, thus avoiding wear on the records. They will be found economical, as the possession of a simple device permits of re-pointing several times, to the best advantage. Drop in and hear it.

(Name of firm)

When a Needle's Needed

When you next need needles try the "B and H" Fibre Needle for your talking machine. You will find it just the needle you have been needing for a long time. You need it for tone, for a natural reproduction without that scratching noise, for non-injury to the record, and because they may be used over and over again, then re-pointed and used a number of times with the best results. Drop in for a demonstration.

(Name of firm)



AUGUST J. TIMPE PASSES AWAY FOLLOWING OPERATION

Treasurer and Business Manager of Edward Lyman Bill, Inc., Dies in St. Luke's Hospital After Operation for Appendicitis—Had a Brilliant Record in Business and Political Circles

With sincere regret we announce the death of August J. Timpe, treasurer and business manager of Edward Lyman Bill, Inc., publisher of The Music Trade Review and The Talking Machine World, who died in St. Luke's Hospital, New York, at 2.30 Wednesday morning, August 14, following an operation for appendicitis.

Mr. Timpe, who was only thirty-five years old, was apparently in the best of health, and planned on the Friday before to take a week-end trip to the seashore. He complained of some stomach trouble, which was ascribed to



August J. Timpe

the effects of the hot weather, and was finally compelled to return home. Physicians tried to give him relief, but he grew steadily worse, and on Saturday he was rushed to the hospital and was operated on immediately. Despite all efforts, however, peritonitis set in, and the patient succumbed.

Mr. Timpe's loss is severely felt by this organization, both in a business and personal sense. Entering the service of the late Edward Lyman Bill over ten years ago as bookkeeper and cashier, Mr. Timpe, through conscientious

effort and the display of keen executive ability, advanced rapidly, until upon the death of Mr. Bill he was placed in charge of the business end of the organization, which he handled capably and well.

Those associated with Mr. Timpe held him in the highest esteem for his many sterling qualities, and feel that in his death they have suffered the loss of a strong personal friend. He was a quiet, unassuming, clean living man for whom the future apparently held much both in a business and political way.

Mr. Timpe was born in New York City, his parents and family moving to West New York, N. J., when he was quite young. In that town he displayed a keen interest in civic and political affairs, and was elected to various positions of trust in its local government. At the time of his death he was councilman, to which office he was elected last November, his great personal popularity being demonstrated by the fact that he was elected on the Republican ticket in an overwhelmingly Democratic ward. He had been spoken of as the next likely Republican candidate for mayor. He was identified with the Boy Scout movement and was a member of the Scout Council.

Mr. Timpe was a member of the Junior Order of American Mechanics and other clubs and fraternal organizations, and the tributes paid his character by the New Jersey papers, and his friends in political and social spheres, afford eloquent testimony to his popularity and the esteem in which he was held.

Mr. Timpe is survived by his parents, a brother, George Timpe, now at Camp Dix, and three sisters, to all of whom The World staff tenders its sincerest sympathy.

The funeral was held from the late residence of the deceased, 164 Fifteenth street, West New York, N. J., on Saturday afternoon, August 17, and was most impressive. Owing to Mr. Timpe's prominence in West New York a great crowd attended the services at the house, which were conducted by the Rev. George Steiner, of West Hoboken, who delivered an eloquent tribute to the character and standing of the deceased. The staffs of The Music Trade Review and The Talking Machine World attended the services in a body, as did the Mayor, Councilmen and other city officials of West New York, detachments from the Police and Fire Departments, delegations from the Junior Order of American Mechanics, the Republican Club and other organizations.

The esteem in which Mr. Timpe was held was indicated by the mass of floral offerings which filled to overflowing the room in which the body lay in state. At the conclusion of the services the casket, draped in an American flag, was carried to the hearse by six pallbearers through a double line of uniformed police, firemen and city officials, who accompanied the body to the limits of the city, while thousands in the streets bared their heads in a last silent tribute. The City Hall was draped in mourning and flags throughout the city were at half mast.

The interment was in beautiful Fairview Cemetery, North Bergen, overlooking the broad expanse of the valley of the Hackensack.

SALES HELP FOR DEALERS

ANSONIA, CONN., September 3.—The Duo-Tone Co. of this city have had prepared an additional sales help for their dealers in the form of an exceptionally attractive counter display stand. This "silent salesman" contains twelve Duo-Tones and twenty-four packages of De Luxe needles. It is attractively cut out and set up on an easel and of an appearance well calculated to attract the casual passer-by.

Take care of the Thrift Stamps and the Liberty Bonds will take care of themselves!

UNCLE SAM KICKS KAISER TO MUSIC

Canned Chastisement Amusing to Sidewalk Crowds.

Uncle Sam, in front of a large and enthusiastic audience, spent most of yesterday kicking Kaiser Bill where such kicks belong. The kicking kept time with martial airs played on a phonograph.

The little "Kaiser kicking toy" is for attaching to phonographs so that when songs which have as their theme the "canning" of the Kaiser are played the hearers can visualize the "canning."

The above appeared editorially in the New York Sun.



UNCLE SAM AND KAISER BILL

Uncle Sam Boots Kaiser Bill in Vigorous Yankee Fashion and Boxes his ears to the music. Kaiser Bill is running away as fast as he can go dragging his "U-Boat Pretzel" with him. Uncle Sam attractively painted in four colors. A great novelty and attraction at this time. *Item 100E Retail \$1.50*

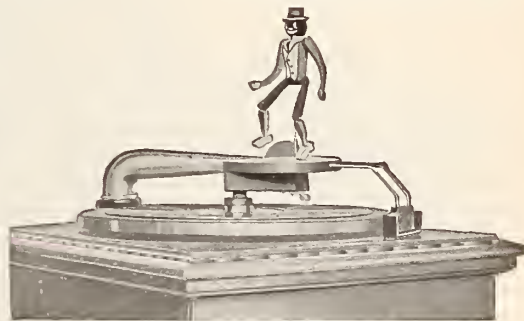

RAGTIME RASTUS
PATENTED MARCH 16, 1915.

One of the Funniest Dancing Toys ever made. Rastus is the Original Ragtime Coon—doing one hundred different steps to music. Attractively painted in four colors, dances well with any lively record and amuses children and grown people. *Item 100A Retail \$1.25*

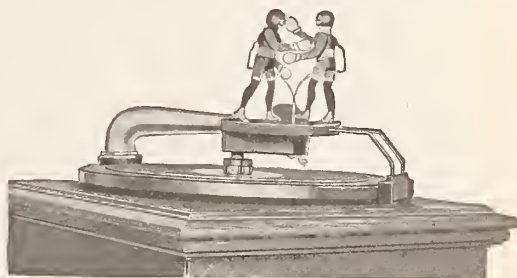

THE BOXERS
PATENTED MARCH 16, 1915.

These little fellows box merrily and heartily as the music plays, uppercuts and overhead swings, fancy footwork, all are very realistic and funny. *Item 100B Retail \$1.50*

COMBINATION RASTUS AND BOXERS

Dancing Rastus and Boxing Darkies, the two sets of figures combined with one mechanism all in one box—two toys in one.

Item 100AB Retail \$1.75 (very popular)

Wholesale and Export discount, in dozen lots of one kind or assorted, 33 1/3 per cent. In three dozen lots of one kind or assorted, 40 per cent.

NOTE.—Owing to unusual conditions, shortage of labor, fuel, possible embargoes, etc., we urge the trade to place orders for early shipment.

NATIONAL COMPANY

Mechanical Specialty Manufacturers
281 Congress St., Boston, Mass., U.S.A.

Increase Your Record Sales

by forcing the owner to maintain his files

DO IT

by furnishing him a file index which he will use

Proper Index is the Secret The Handy Record Index

EASY TO MAKE
EASY TO KEEP
EASY TO USE

In Convenient Form

for the owner to hand to his friends in answer to their question of "What records have you?"

Its Use A Pleasure

inducing the proper maintenance of files and thus the

PURCHASE OF MORE RECORDS

HARRISBURG BOOK CO.
Commonwealth Trust Bldg.
HARRISBURG - - - PENN.

Columbia

The New Cabinet Designs

Consider the sales possibilities of the new model Grafonolas as examples of beautiful furniture.

Exquisite in craftsmanship, constructed according to the highest standards of the cabinet maker's art, these new Grafonolas are so chaste, so simple, so conservative in design that they harmonize perfectly with the decorative effects of all the best known periods.

Think what this means to the architect, the interior decorator, the American home owner of taste and refinement.

Study these new designs, learn their wonderful appeal as furniture, as well as for the reproduction of music, and you will have added to your selling talk a point of inestimable value in the sale of your Grafonolas.

Columbia Graphophone Co., New York



Columbia
Grafonola
Type E-2
\$90
Retail



Columbia
Grafonola
Type G-2
\$115
Retail

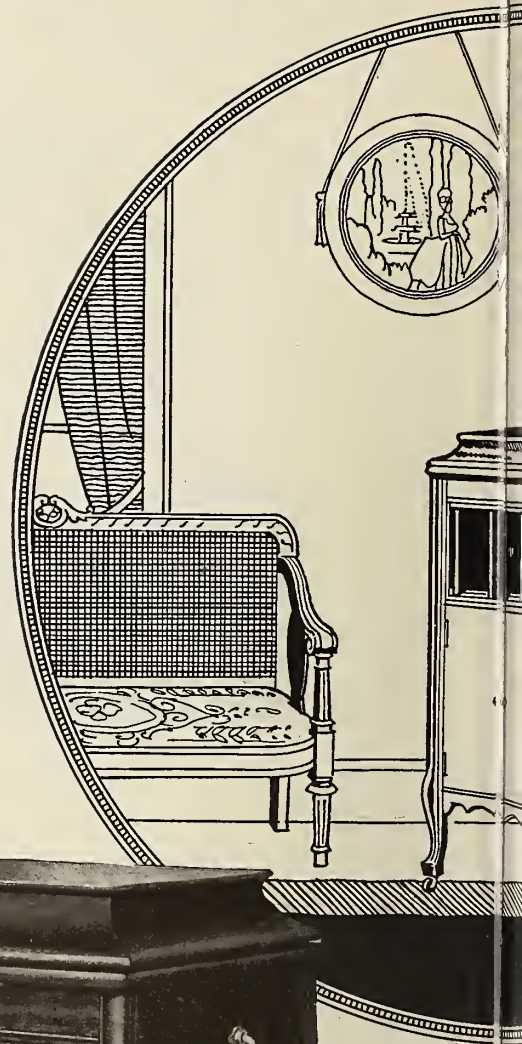

Grafonola

The Non-Set Stop

Every new model Grafonola is equipped with the Columbia Non-Set Automatic Stop!

Nothing ever introduced to the phonograph trade means so much *to the dealer* as this marvelous piece of mechanism.

It is the *only* non-set stopping device on the market. It is simple, sturdy, fool-proof—infallible in action.

It is protected by hundreds of patent claims—you are beyond competition when you feature it.

People like it. They are instantly interested in it. And that means easier sales—bigger profits for *you*.

A timely sales-hint—have your customers trade in their vacation models for Standard New Model Grafonolas with Non-Set Stop.

Columbia Graphophone Co.
New York

Sell Foreign Language Records
Full information from
International Record Department
102 West 38th Street New York

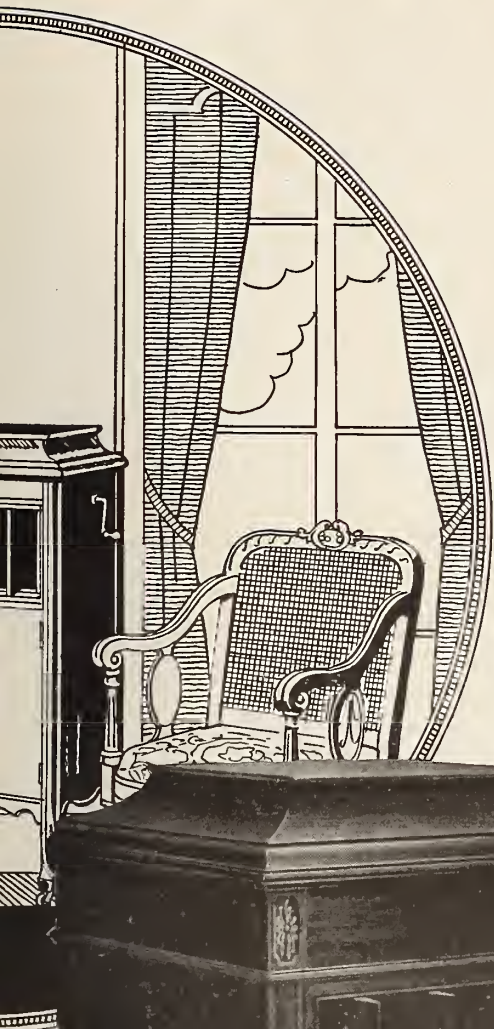

Columbia
Grafonola
Type K-2
\$175
Retail



Columbia
Grafonola
Type L-2
\$225
Retail

NEW EDISON AIDS SCENARIO WRITER

Monte M. Katterjohn Pays High Tribute to the Inspiration Producing Qualities of the New Edison Phonograph—Suggests Plots

Monte M. Katterjohn, staff author at the great Lasky motion picture studios in Los Angeles,

that the phonograph has now taken its place as the source of inspiration for many of the successful motion pictures of the day.

"The question of 'where the stories come from'," said Mr. Katterjohn, "is answered to a great degree, in my case at least, in the various selections which I have played on my Edison phonograph. I have obtained the ideas for sev-

supplies only a basis for development, the germ of the story is there, and there remains only the necessity of clothing the plot with incidents and elaborating upon the idea.

"On the other hand, a melody may inspire a mental picture, and result in a story that will have not the remotest resemblance to the theme of the song itself. It is simply that the melody suggests a train of thought, and the idea persists in spite of its conflict with the thought of the song writer.

"There is unlimited inspiration in music, and the New Edison supplies it in the handiest form in which it is available to the writer."

FRANK J. BAYLEY'S GENEROUS ACT

Detroit Piano Man Gives Use of Grounds for Patriotic Carnival of Friendship Lodge

DETROIT, MICH., August 27.—Frank J. Bayley, dealer in pianos and "talkers," displayed a commendable patriotic and Masonic spirit of generosity by turning over the spacious grounds of his residence at 99 Chicago boulevard for an elaborate patriotic lawn carnival to be conducted on August 28 and 29 under the auspices of Friendship Lodge No. 417, F. & A. M. The purpose of the carnival is to raise a war fund for the lodge to take care of the needs of the 200 members in the service of the country. In addition to giving over his lawn, Mr. Bayley is also acting as business manager for the carnival. A program of more than ordinary interest has been prepared.

A certificate of incorporation has been issued to the Palace Talking Machine Shops, Inc., of Manhattan, for the purpose of manufacturing and dealing in talking machines. The capitalization of the concern is \$25,000, the incorporators being S. Birns, A. Bendersky and M. Glossom.

No quarter for the foe, but many quarters for Thrift Stamps. Buy some to-day.



Monte M. Katterjohn Listening to the Edison

author of some of the biggest "movie productions" of the past year, recently paid high tribute to the New Edison as an aid to writing motion picture plots. Incidentally he shows the universal power of music and reveals the fact

eral of my most successful productions through simply listening to the re-creations that I have purchased for the instrument in my home.

"Very often the words of a song will suggest the basic idea for a story, and while the idea

GIVES A PURE NATURAL TONE TO YOUR RECORDS

THE FLETCHER REPRODUCER

Others CLAIM it

EXACT SIZE

WE PROVE IT

After years of practical experience and experimenting, we are pleased to offer a Reproducer constructed on entirely new principles. In its natural reproduction of tone, either vocal or instrumental, it astonishes and pleases beyond expression, and a Caruso, Galli Curci or Heifetz sounds as if the artists themselves were before you.



The Fletcher Reproducer is different from the ordinary sound box, not only in construction, but in results. You hear no metallic noises, but an accurate reproduction of the human voice or musical instrument as it is recorded. If used with a fibre needle it will give practically as much volume as with a steel needle and save the wear on the record. The Fletcher Reproducer brings out detail on the record that cannot be heard with the ordinary sound box.

The Fletcher Reproducer is different. Hear it and be convinced. A sample order carries with it a guarantee of satisfaction or money refunded. Samples to dealers and manufacturers \$4.00.

Write for prices and terms in quantities.

FLETCHER-WICKES CO. 6 E. LAKE STREET CHICAGO - ILL.

Persistent and Consistent Advertising the Greatest Protector of Business in Wartime

Advertising has well been termed the "policeman of American business," not that it hunts criminals and makes arrests directly, but it acts as a protector of the business interests of the present and future through keeping those interests in the public eye.

For manufacturers in any line to stop advertising during the period of the war just because their business is not as profitable as in peace days, or because they cannot meet demands, is equivalent to discharging a police force in the time of riots.

This is the psychological time to study advertising as never before—to study it not for immediate results, but for the effect that it will have in the maintenance and development of business after the war.

Elimination of advertising at this time indicates that the manufacturer does not expect to stay in business until the dawn of peace, and yet his whole thought should be focused on keeping things going until that welcome hour.

Advertising does two things primarily—it creates a demand for a certain product, and, more important still, it establishes a name value for that product among the public at large—a name value that is worth thousands, or millions, of dollars, as the case may be, because it cost that much to create it.

Automobile, talking machine and other manufacturers who have built up their prestige on the strength of a name and the quality back of that name are now unable, and will not be able, probably for the period of the war, to supply the current demands for their products, yet they advertise persistently and consistently and the advertising is not designed so much to secure trade as it is to keep the trade mark or name constantly fresh in the public mind, so that when the output again can keep pace with the demand the product will have lost none of its reputation or familiarity.

The Government has taken over the entire output of a number of manufacturers, yet most of those manufacturers are continuing to advertise just as much as before without being able to offer a dollar's worth of their product to the public.

Why do they advertise? Simply for this reason: the war is not going to last forever, and the Government is not going to require their entire output after the war. When peace is declared these manufacturers will again have to come to the civilian market and they do not want to go through the slow process of building up popularity and reputation all over again. In other words, it is much cheaper to continue advertising at a normal rate than it is to stop altogether for the period of the war, and then

carry on enormous publicity campaigns after peace comes to re-establish prestige, or to try and wrest that prestige from some competitor who has kept right on telling the public about his product.

The manufacturer who stops advertising will not only have to spend time, money and effort to get his market started again after the war, but will also have to face the competition of those who, possibly insignificant in his eyes now,

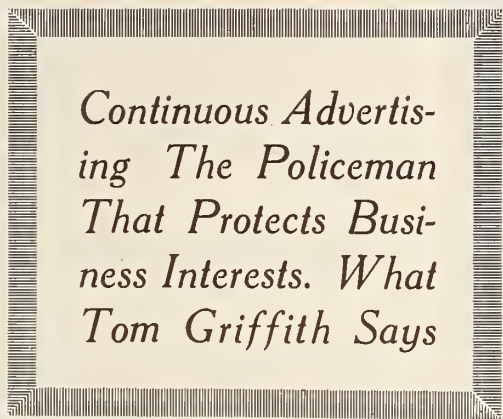

Continuous Advertising The Policeman That Protects Business Interests. What Tom Griffith Says

nevertheless had courage to plan, work and advertise for the future.

The necessity for advertising consistently and continuously during the period of the war is particularly well set forth by Tom Griffith, sales manager of the Udell Works, Indianapolis, Ind., the well-known cabinet manufacturers, who, in an interview with *The World* summed up the situation as follows:

"In a recent dispatch from the American Expeditionary Force in France, an American officer is quoted as saying to a German commander, who, because of his numerically superior force, had asked the American officer if he wanted to surrender, 'Hell, no, we are just getting ready to attack.'

"A pretty good moral here for some of us weak-kneed manufacturers. Eh, what?"

"Because they are busy and because of the labor conditions and because of inadequate raw materials, some manufacturers are letting the fire die down under their advertising boiler, which is the biggest asset they possess.

"Of course, things are upset, and, of course, it's hard to do business and unquestionably it's going to get worse before it gets better, but that is just the reason why you should everlastingly keep dishing up to your trade that real hot stuff, 'Hell, no, we are just getting ready to attack,' and show them that even the biggest war of all times is not going to cause you to

lose your identity that it has taken years to build.

"I know this country has only one job and that is to win the war, but I also know that it isn't going to be won if the manufacturing interests of this country crawl into holes and pull the holes in after them.

"That is just what it means to lose the good will that you possess with your trade, and the wise manufacturer to-day is building for the post-war, reconstruction period.

"Really there is one sane, sensible, down to earth policy and that is to keep on keeping your name before the possible buyers of your product even if you haven't a dollar's worth of merchandise to ship them. The big men with vision, the successful ones, are doing it, and it is a pretty good bet to follow the lead of the real successes.

"Cut out advertising now? Such a procedure is just plain criminal and there ought to be a city ordinance that would take care of such culprits."

BETTER BUSINESS BUREAU REPORTS

No Complaints Regarding Talking Machine Advertising Handled in July—Attention Called to Federal Trade Commission Ruling on Advertising of Used Instruments

MILWAUKEE, Wis., August 26.—The Music Industries Better Business Bureau, with headquarters in this city under the direction of C. L. Dennis, has issued a most interesting report regarding its activities during the month of July, when twenty-nine cases were investigated, all of them referring to the advertising of pianos. For the first time in some months the bureau was not called upon to take action upon the advertising of talking machines.

In perusing the report it is interesting to note that more than half the cases taken up during July involved violations of the recent ruling of the Federal Trade Commission forbidding the advertising of used, second-hand, repaired or rebuilt musical instruments, in which it was not distinctly and definitely stated and set forth that such instruments had been used and were second-hand, repaired or rebuilt. Such advertising is also in violation of the advertising laws in many States.

Although the sale of used instruments does not figure very largely in the talking machine trade at the present time, it might be well for talking machine dealers to bear in mind the Federal Trade Commission ruling in the event that they do have used instruments to offer to the public.

Dayton Motors

**Sold all over the world
Used in all high class
Talking Machines**

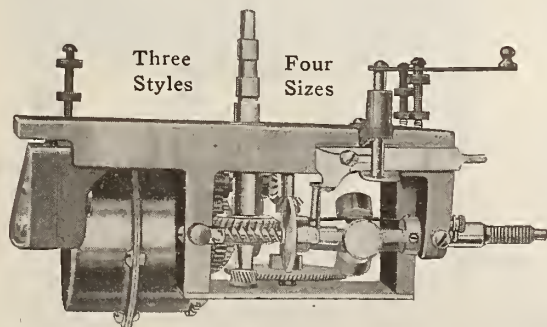

They have won wonderful and enduring popularity and embody the silent running, reliable and durable features that delight the customer and satisfy the builder. The Dayton Motor is considered by manufacturers and users as being

The Best Built Motor in the World

It has made good in Thousands of machines. Give us an opportunity to prove it.

Build satisfaction into your products by using our Quality Line—Dayton Motors, Dayton Tone Arms, Dayton Reproducers. All styles and sizes. They will bring you more business and satisfy your customers. Write for full particulars.

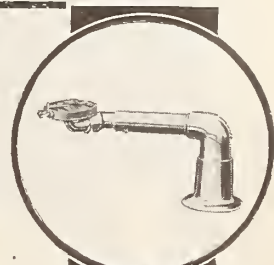

THE THOMAS MFG. CO., 322 Bolt Street, DAYTON, OHIO, U. S. A.

Mr. Dealer:

Exclusive Territory is waiting for live merchants for our Tel-O-Tone instruments. We are making prompt deliveries. You can get the goods.

(We will not take on more Customers than we can absolutely supply promptly)

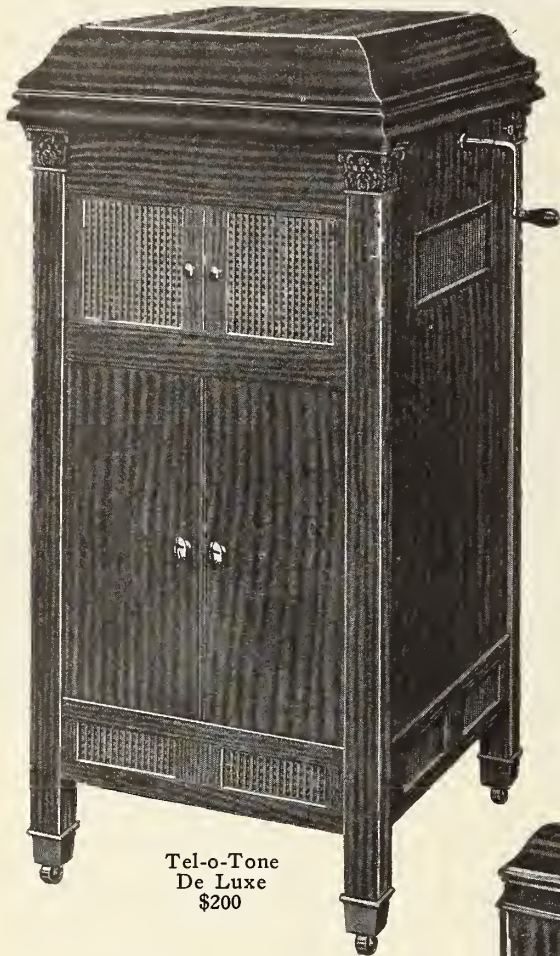

Tel-o-Tone De Luxe \$200

Entirely New to Phonographs

are the exclusive features of "Tone-Separator," "Reducto" and "Tone-Resonator" found only in the Tel-o-Tone—which is claimed to be the only facsimile reproducer of music. Full particulars and

Our 18 Page Catalog Fully Illustrated

are at your service—including booklet of "Inside Information About Phonographs and Facts About the Phonograph Not Generally Known." We will supply these free in quantities—pre-paid—to all Tel-o-Tone agents for dealers' imprint.

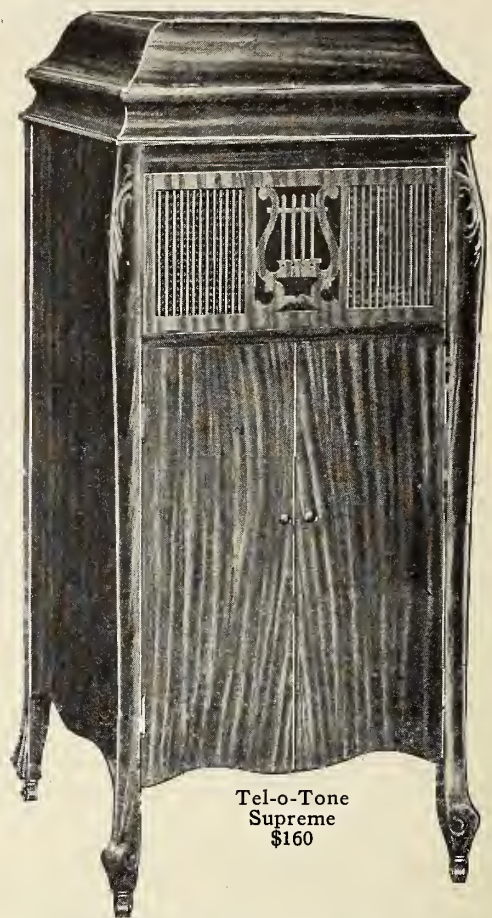

Tel-o-Tone Supreme \$160

Terms—Pleasing
Discount—Attractive Service—Satisfactory
Advertising—Co-operative

The only instrument in the world playing perfectly and equally well every make of disc records with the ordinary steel needle and absolutely no change of equipment. Investigate.

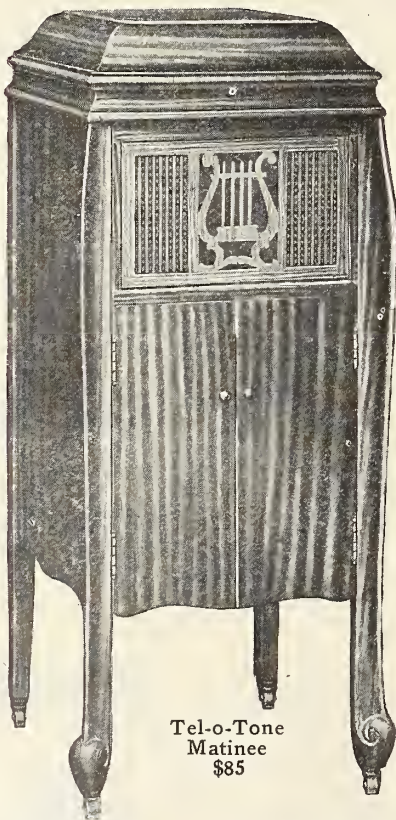

Tel-o-Tone Matinee \$85

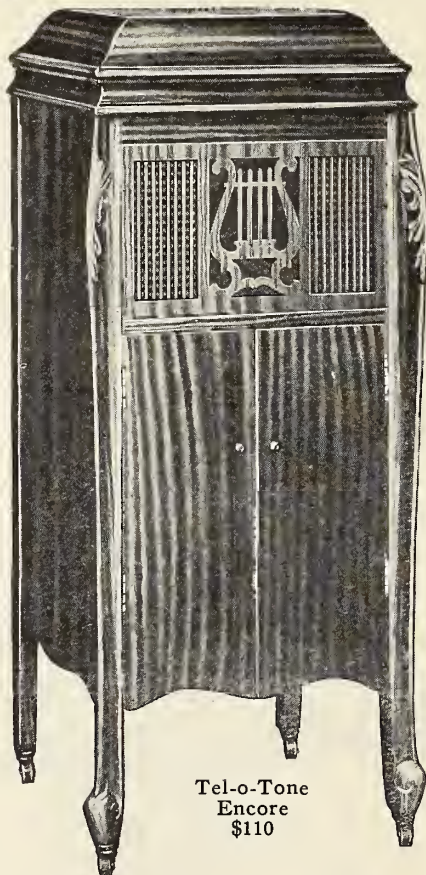

Tel-o-Tone Encore \$110

We have no competition in tone. To fully appreciate the wonderful tone effects from the Tel-o-Tone tone chamber it must be heard. Order out samples. If they do not prove beyond your expectation, instruments may be returned at our expense.

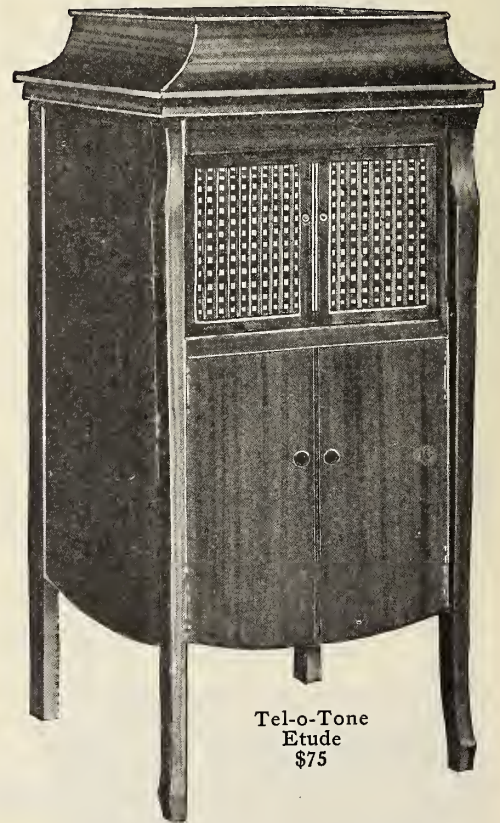

Tel-o-Tone Etude \$75

May we mail Full particulars to you?

We are manufacturers of the Tel-O-Tone and we guarantee every instrument—'Nuff Sed.

The Western News Company, 21-29 E. Austin Ave., Chicago, Ill.
RETAIL DISPLAY ROOM: 730 Republic Building, State and Adams Streets, Chicago, U. S. A.

Will you Write Us To-Day?

WHY SECOND-HAND MUSIC FOR A NEW, FIRST-CLASS WAR?

"Boys in France Don't Want Records of Music That Was Old When the 'Star Spangled Banner' was Written," Says Smith, the Talking Machine Man, and He Makes His Arguments Pay

Smith was in a pensive mood. He sat with his dogs on the counter thinking seriously while he wrecked a chiclet beyond repair with his jaws and hummed softly, "Why Do They Call Them Babies When They Mean Grown Up Ladies." His thoughts were divided between his Wednesday night date with his patootie, and whether the old man had come home with a grouch and the probable effect of the new Man Power Law, in making him work or fight. Smith was a peaceable guy and hated work, so he had cause to ponder.

Business was punk with Smith, because the new records and the popular styles of machines were as scarce as dollar bills in the poorbox. He had tried newspaper advertising on a piker basis, but the result was a flivver. He spied his head off to the customer, but couldn't get action. So far as he could see the crepe was getting nearer and nearer and the business undertaker was rubbing his hands.

Finally in blows a big blonde with a nifty little book in her hand. "Can't come across," says Smith, beating her to it. "The rest of the gang got to me first." "How d'you get that way?" quotes the frail, "I ain't asking you for nothin', all I want is a favor." "But I don't want to get married," says Smith. "Haven't asked you about your personal desires," was the comeback from the Jane. "The big idea is this. We are collecting musical instruments for the boys in the service. We want anything from a jews-harp to a grand piano, and I am trying to find places where the public can leave their presents. You seem to have plenty of room here, but not much to do with it. Why not make your store a receiving station?" "But it will take time and trouble to handle the stuff," says Smith. "Well, it takes the guys in the trenches time and trouble to wallop the Huns," was the answer, "but they ain't complainin'."

"All right," says Smith, "to save argument, put the sign up."

He gave the poster the up and down and gets a hunch he can go it one better. He puts his own sign in the other side of the window reading:

Send some records to your soldier friends.
Send them new records.
Don't give them the junk grandma bought.
Uncle Sam supplies them with the best grub he can buy, so why not feed them with the best music?
If I haven't what you want here I can get it for you.

The sign was there all right and got many a laugh, but it also got the gang to thinking and also buying. An old lady blew in with the remark: "I got two boys in France and I want some records for them." Smith asked how old they were and where they hung out before they went in the army. He doped it out that they were cabaret hounds and simply fed the old lady up on jazz. When those boys hear the music of the records in the dugout they will feel like kissing Smith.

A benevolent-looking party came trotting in one day with a bundle under his arm, which proved to be a bunch of the first records that had ever been put on the market and which bore music that was old when "The Star Spangled Banner" was written. "What are you going to do with that junk?" says Smith. "Send it to the soldiers," says the visitor. "You ain't a German, are you?" says Smith. "Certainly not," yells the benevolent party. "Well, what do you want to break a couple of good soldiers' hearts for?" says Smith. "You ain't sending over any tobacco that you smoked or chewed, are you, just because you're through with it?" "Certainly not," was the indignant answer.

"Then why send a bunch of moss-covered tunes to some of the finest boys that ever hit the pike? This is no second-hand war, but a brand-new, first-class proposition. Maybe you figure out you won't have to buy so many War Savings Stamps if the Government uses second-hand guns." The old boy rears up and swears he is insulted. Smith goes right on telling him where he is wrong, until the old gent backs up and gets out. Next day he blows in again, hangs his head, and buys a dozen records of Smith's selection.

A sweet young thing comes in struggling under the weight of a ukulele. "What are you going to do with that thing?" asks Smith. "Send it to a camp," says the skirt. "Well," says Smith, "buy a couple of records and send them along so that the boys can have some music while learning to play the uke. What's a couple of bucks at a time like this?" The chicken falls for the argument and pours out some of her pin money.

At the end of the first week Smith was doing real business. "I got the right dope on the work or fight stuff," he says. "I got to work to make 'em see the idea of the right way, and then I got to fight 'em to make 'em come across. Camps are not dumping grounds for a lot of records that owners want to throw out of the house. If they don't want them home, what good are they to a guy who is seeing things and is three jumps ahead of the fellow in the morris chair? From the bunch of 'Poor Butterfly' records that have been offered to the soldiers there must have been a lot of moths around somewhere, and who would be mean enough to sic a moth on a boy in khaki?" "Come clean" is Smith's motto. "Give them the music they like to hear, and so make the giving a sacrifice instead of an excuse for cleaning house."

Dictionaries define initiative as the ability to start or originate. It is one of the four ingredients in the prize recipe for success—the other three being imagination, industry and in-thusiasm!

LONG CABINETS



No. 83

In all finishes. Specially adapted for use with Columbia 50. Front posts made to follow lines of posts on Columbia 75.

FIRST and FOREMOST

In the cabinet field.

Why? Because we've *specialized* in

**CONSTRUCTION
FINISH and
ADAPTABILITY**

Our supremacy in these essentials warrants your handling *the perfect line.*

That's why you should anticipate your wants **NOW.**



No. 79

In all finishes. Shown with top moulding and shelves. Specially adapted for use with Victrola IX-A.

Prompt deliveries on all orders. Write for Illustrated Catalogue of complete line

THE GEO. A. LONG CABINET COMPANY
HANOVER, PA.

PITTSBURGH TRADE WARNS PROSPECTS OF PRICE RAISES

Urge Early Buying of Machines and Records as a Money-Saving Proposition—Indications of Brisk Trade for Fall—Buehn Attends Executive Committee Meeting—Other News

PITTSBURGH, Pa., September 5.—A. R. Meyer, manager of the Victrola department of the Joseph Horne Co., has sent out the following notice to the patrons of the department. It read as follows:

"About this time last year indications led us to predict an advance in Victrola prices. This prediction was conveyed to our customers by a special letter, similar to this one. A few weeks later the prediction was verified, and customers who availed themselves of the advance information were enabled to make a substantial saving on the prices of their Victrolas.

"Another increase in prices appears imminent. With the decrease in social activities since the beginning of the war, the Victrola has developed into a chief factor in home entertainment. It plays the martial airs, sings the cheering war songs, and brings the comfort and solace of music into homes made lonely by absent ones.

"If you are considering a Victrola for the indoor days ahead, it is advisable to place your order at once, to enjoy the benefit of present prices. Victrolas are priced here from \$22.50 upward. In the purchase of the larger machines, convenient terms of payment may be arranged with the department of accounts."

Mr. Meyer has under his supervision a well arranged Victrola department on the mezzanine floor of the Joseph Horne Building. The demonstration rooms are well lighted and especially well adapted for the purpose of securing the best results in demonstrating Victrolas and Victor records. Mr. Meyer has a corps of capable and efficient young women as his assistants. The past month was noted as exceptionally good and the trade was far in excess of that transacted for the same period a year ago.

A visit to the offices and showrooms of Gray & Martin, distributors of the Sonora Phonograph, found both members of the firm very enthusiastic over the outlook that the coming fall seemingly indicates a brisk trade. It was stated that there had been a number of inquiries by prospective customers the past two weeks concerning the Sonora phonograph and it was stated that sufficient sales had already been booked that would make the month of August a banner period for the summer. Gray & Martin have well-appointed demonstration rooms located in the Jenkins Arcade Building. The firm also specializes in the Emerson records,

the sales of which, it was stated, were very large and showed marked signs of increasing as their popularity became larger.

Edward A. Ferguson, formerly assistant manager of the Cleveland branch of the Columbia Graphophone Co., has arrived overseas safely with his contingent, the Second Provisional Co. of Engineers. Mr. Ferguson is a native of Pittsburgh and was trained at Camp Humphreys, Va., before being assigned to France. He was called into service May 26 last.

Manager S. H. Nichols, of the Pittsburgh wholesale branch of the Columbia Co., stated to the Talking Machine World representative that the month of August was a most notable period for business not only in Grafonolas, but in Columbia records as well. He said that the local dealers had excellent window displays and these with the aid of judicious newspaper advertising and other mediums of publicity proved to be drawing cards for business. He anticipates that fall trade as far as the Columbia Co. is concerned will be the greatest in the history of the Pittsburgh branch. A feature of the month was the special sale of the Pershing and Gerard records, which were well received by record buyers.

Dauler & Close, who are making a special campaign for the sale of the Cheney phonograph, report sales during the past month as rather brisk. The firm, which is one of the oldest furniture houses in western Pennsylvania, have a well-arranged demonstration room on the sixth floor of their building, where various styles of the Cheney phonograph are displayed. The \$150 and \$225 priced styles, it was stated, were the best sellers.

A. A. Buehn, of the Buehn Phonograph Co., Edison distributors, attended the meeting of the executive committee of the Edison jobbers which was held at Chicago, August 27, at the La Salle Hotel. The week previous Mr. Buehn was at the Edison plant at Orange, N. J., in conference with the sales department. He then went to Atlantic City and Ocean City for a brief outing, returning to New York on a business errand before coming back to Pittsburgh. Mr. Buehn predicts an excellent fall season for the Edison phonographs and is of the opinion that the Edison Co. will make every effort to supply the trade as far as is consistent with their war-time policy.

Under the direction of the Buehn Phonograph Co., a series of tone tests have been arranged at which Miss Amy Ellerman will be the soloist and Prof. Coxe the director. The dates and places arranged follow: September 9, Johnstown, Pa.; September 10, Roaring Springs, Pa.; September 11, Latrobe, Pa.; September 12, Irwin, Pa.; September 13, Uniontown, Pa.; September 16, Morgantown, W. Va.; September 17, Fairmont, W. Va.; September 18, Grafton, W. Va.; September 19, Buckhannon, W. Va.; September 20, Clarksburg, W. Va.

One of the specials offered by Manager H. J. Brennan, of the Pathé Shop, was a fine Pathé-phonograph, covered model, and equipped to play all records, with a \$13.75 record cabinet and six double-faced Pathé records for \$48.25. The sale proved highly successful and the popularity of the Pathé machine is increasing in this section.

The W. F. Frederick Piano Co. had some excellent publicity recently out of the action of the local dealers in "interning" German records, including records of German music and records by German artists, by arranging an elaborate window display showing the German records piled in a prison with a United States soldier on guard outside the bars. The display attracted much attention.

SHORTENS BUSINESS DAY

Wanamaker Store to Be Open Only From 10 a. m. to 4.30 p. m. During War

In line with the general movement to conserve energy, man power and particularly fuel during these trying times, the great store of John Wanamaker, New York, announced recently through published proclamations in the daily papers that for the period of the war the store would be open only six and a half hours each day, that is, from 10 o'clock a. m. to 4.30 p. m. These hours will naturally apply to the talking machine and piano departments, which are a big feature of this house.

Another department store, Hearn's, has also announced that business hours would be limited from 10 a. m. to 6 p. m., and it is reported that other prominent department stores and commercial establishments in the city, and for that matter in other sections of the country, will follow the same example and shorten their business day. It is felt that all buying can be done in the period fixed, and that if shoppers will arrive and leave before and after the rush hours on the transit lines, congestion there will be relieved materially. The movement is new, and as yet no exclusive music house has announced the change of hours.

STRONG VICTOR ADVERTISEMENT

Effective Two-Page Spread Appeared in the Saturday Evening Post of August 17

An unusually strong and attractive double-page advertisement of the Victor Talking Machine Co. appeared in the Saturday Evening Post of August 17, the main feature being a picture in colors spread entirely across two pages, and more than half the depth of the page, showing Lieutenant John Philip Sousa at the head of his United States Naval Reserve Band, calling forth the strains of "The Stars and Stripes Forever." The caption of the ad read: "The greatest bands of all the world parade before you—on the Victrola." The advertisement was particularly timely and effective.

EDISON GOES SOUTH ON AUTO TRIP

ORANGE, N. J., August 29.—Thomas A. Edison, John Burroughs, the naturalist; Henry Ford, Harvey Firestone, Edward N. Hurley, Director of the Shipping Board, and Prof. De Loches, of Chicago, have started on a camping trip through the South. The trip is being made by automobile, and sufficient supplies have been taken to last for several weeks. The journey south will be made by easy stages, traveling through the day and making camp at dusk.

Ward's Khaki Moving Covers



Grade "D" Cover with No. 3 Straps.

PROTECT YOUR MACHINES FROM ALL KINDS OF WEATHER

and will enable you to deliver them free from dust, scratches, bruises and all other finish destroyers

Our covers are faced with Standard Khaki, lined with a heavy grade flannel, interlined with an exceptionally good grade of heavy cotton or felt, diagonally and closely quilted, and manufactured according to the usual superior "WARD New London" quality.

Grade "D", medium size, \$6.00
Grade "D", large size, \$6.50
Grade "K", medium size, \$8.00
Grade "K", large size, \$9.00

Carrying Straps: No. 1 \$1.00; No. 2 \$2.00; No. 3 \$3.50

ORDER SAMPLE COVER ON APPROVAL

With Name of Machine silk embroidered on any Cover; extra, .30c.
With Dealer's Name and Address, first Cover; extra, \$1.15
Same on additional Covers, each extra, .60c.

Write for booklet

THE C. E. WARD CO.

(Well-known Lodge Regalia House)

101 William St., New London, Ohio

Also Manufacturers of Rubberized Covers and Dust Covers for the Wareroom

AEOLIAN VOCALION RECORDS

One of the Most Important Announcements Ever Made in the Phonograph Field

■ ■ ■

ON the two pages following is reproduced the announcement by The Aeolian Company of its latest achievement—the *NEW VOCALION RECORD*. The third page carries one of the impressive newspaper advertisements which is part of the campaign of publicity for the new Record.

The importance of this announcement may hardly be overestimated. To the music-loving public it means the opportunity to hear and in fuller measure enjoy the true performances of artist and musician.

To the music trade it means one more vital sales-feature added to the many already possessed by the most distinguished, interesting and saleable phonograph upon the market today—the Aeolian-Vocalion.

The new Vocalion Record is a super-record. Its musical quality far surpasses that of any records hitherto produced.

This record is exclusively available to the owners of the Vocalion. Moreover, due to this phonograph's Universal Tone-Arm—the simplest and most satisfactory device of its kind—*all other records are also available to the Vocalion owner*. This is a sales-appeal which no prospective purchaser will fail to grasp.

Added to the Vocalion's manifest superiority of tone, its exclusive playing device—the Graduola—its unapproached beauty and variety of case designs, and its ability to play *all records* (including this new and greater one), put the Vocalion in a class above and apart from all competitors.

AEOLIAN VOCALION RECORDS



The New

VOCALION RECORD

*A Revolutionary Phonograph Record
Produced by The Aeolian Company under an
Entirely New and Advanced System*

IN this important announcement is chronicled the second great step taken by The Aeolian Company in its development of the higher musical values of the phonograph.

First: the Aeolian-Vocalion—that wonderful phonograph which three years ago startled the musical world and leapt almost overnight into the premier position among all such instruments.

Second: The Vocalion

Record — giving the Aeolian-Vocalion, for the first time, a Record fully worthy of its extraordinary powers of reproduction.

*Product of the World's
Leading Music House*

FOR nearly half a century, the Aeolian Company has maintained its position as the foremost creative influence in the music industry. As a source of invention, progress and improvement, no other house has even re-

motely approached this Company's notable record of achievement. Today, The Aeolian Company stands without a rival in its comprehensive understanding of music and its broad and scientific knowledge of the various instruments for producing it.

The New Musical Values of the Vocalion Record

THE phonograph record itself is a marvelous invention. To hold in an inert and inarticulate disc the melodious notes of a human voice—the vibrant tones of a violin—almost baffles comprehension.

If these notes and tones have hitherto fallen a little short of nature—if some character, some richness, some of the more delicate qualities have been lost in their recording—it is no wonder. The only wonder is the marvelous nature of the results accomplished.

The new Vocalion Record comes a sympathetic step nearer to reality.

Where with the old system only the broader, stronger elements in any tone could be recorded, the new system records the tone in its entirety. The finer overtones—those subtle partials that give to every instrument and voice its final touch of individuality and beauty are, for the first time, caught and imprisoned by a far more delicate and scientific method.

Those who hear the new Vocalion Record are conscious of new impressions. To sight the phonograph remains—to hearing it is gone. The tendency to stridency—the lack of richness and of body—the vagueness of individuality—all the effects hitherto typical of even the best phonograph performances are replaced by natural varieties of sound.

AN INVITATION—At Aeolian Hall, on West 42nd Street and at The Aeolian Company's various Branches in the Metropolitan district, the new Vocalion Record is now on exhibition. The numerous owners of the Aeolian-Vocalion, the owners of phonographs of other make and all persons to whom progress in music is of interest, are cordially invited to the public informal demonstration of these Records, which for the present will be continuous throughout the city.

THE AEOLIAN COMPANY AEOLIAN HALL

NEW YORK LONDON PARIS MELBOURNE
 SYDNEY MADRID



Florence Easton
of the
Metropolitan Opera Company

THIS distinguished soprano has made an individual place for herself in European operatic circles, and has been hailed as the most valuable acquisition the Metropolitan Opera Company has had in years.

Florence Easton's characterizations during the past season in "Cavalleria Rusticana," "L'Oracolo," "Lodoletta," and in the title role of Liszt's "St. Elizabeth," have established her as a gifted artist of rare attainments.

AEOLIAN-VOCALION

Prices are \$50 to \$350.
Graduola Models from
\$115. Prevailing Period
Styles at moderate prices.
Catalogues sent upon request.



STYLE "G"
PRICE \$115

A Vocalion Record

of rare charm

"THREE GREEN BONNETS"

Sung by
FLORENCE EASTON

ONLY a wistful little musical tale—but sung by a great artist with a heart-stirring appeal that will make this Vocalion Record a *cherished possession*.

Three tiny maids in quaint green bonnets who have spent the carefree days of childhood together—blue-eyed Daisy, little Dulcie of the clear grey orbs, and brown-eyed Dorothy May.

With what exquisite tenderness of tonal beauty does Florence Easton, the famous soprano of the Metropolitan Opera Company, invest the name of Dorothy May—fore-shadowing in the very simplicity of her artistry the song's plaintive finale—when the angels have called home the little brown-eyed maiden.

Think of the satisfaction of being able to follow *every word* of d'Hardelot's charming ballad in this marvelous Vocalion Record.

Through the impressive tone-realism of The Aeolian Company's new and improved system of recording, not only is the individual quality of Florence Easton's beautiful voice given *amazing reproduction*, but each clear-cut detail of her remarkable enunciation—enabling the listener to enjoy *every syllable* of this rare little musical gem to its close.

VOCALION RECORDS

—representing the highest modern development of record-making and interpreted musically through the *master phonograph*, the *Aeolian-Vocalion*, reveal the limitless possibilities of this exclusive method of tone reproduction.

THE AEOLIAN-VOCALION

PLAYS all standard makes of records with greater tonal naturalness than any other phonograph and bestows upon owners of these wonderful instruments the added advantage of enjoying, through the most satisfying and musicianly medium—the new Vocalion Records.

THE AEOLIAN COMPANY

NEW YORK LONDON PARIS MELBOURNE
SYDNEY MADRID

Ask to hear Florence Easton's delightful records of "Three Green Bonnets" at the demonstrations of Vocalion Records held daily at all Aeolian Stores.

Vocalion Record No. 30002, 10-inch, price \$1.25

Keeping a Proper Account of Record Stock a Great Business Essential :: :: :: By Arthur H. Cushman

Director of Sales, Emerson Co.

One of the most important details, and one that has a direct and very serious influence on the profits of a talking machine record department, is the system used for keeping an account of the stock on hand, and the intelligence and promptness with which reorders for fill-in records are placed.

Many dealers who have had limited experience in the merchandising of talking machine records are inclined to neglect these most necessary details. It cannot be impressed too strongly on the mind of the manager of your record department that it should be his policy to work for minimum stocks on hand, maintained at a point, however, that will give maximum service to the consumer. That is to say, it is most important that a phonograph department carry as small a stock as possible, and yet never be out of live selling numbers. We believe we are fair in saying that many record departments which would otherwise have been a marked success and would have yielded substantial profits have proved unsatisfactory because of the lack of a carefully devised system, or failure to maintain the system effectively, when installed.

It is not our intention, at this time, to specify any particular system for keeping account of stock. It is a problem that every live store-keeper has faced in other lines of merchandise, and all competent merchants are familiar with systems which will easily take care of this feature, and produce satisfactory results, provided, as we have stated before, the system is put into careful operation and maintained at its highest point of efficiency.

The object of this article is to emphasize at this time the importance, especially at this season of the year, of not allowing the accounting of records to become lax, nor neglecting to reorder numbers which are needed so as to keep the stock at its proper point. Nothing harms a department more than an overstock, unless it be a lack of stock of numbers which the customers want.

There is not an element in the merchandising of records that so effectively turns customers to your competitor's store as to come into your department for numbers which you are unable to supply. If they find that your nearby competitor can give them these records and the service they want they immediately transfer their trade to that store. Therefore, it is the important duty of every dealer, or manager of phonograph departments, to assure himself that his stock-keeping system is:

1. A correct one.
2. Is well maintained.
3. That an intelligent placing of orders will result from the keeping of this system.

Failure in any one of these three points will have a very serious effect both on your volume of business and the size of the profits of the department.

Popular and patriotic song and dance hits comprise by far the greatest part of the volume of business done on records. Unless you have these hits when the public wants them your business suffers in a marked degree; and if you have these hits in your stock after the public has stopped buying them your profits will suffer to a very great extent. So the conclusion is definitely set forth that in order to get a volume of business you must have the records in stock, and in order to make a profit it is necessary that you do not have an overstock when the sale for these numbers has ceased.

Therefore your stock-keeping and reorder system must be so arranged that it automatically takes care of stock and reorders as the volume of business on a number slows down.

We hope if any Emerson dealers have not been giving proper care and thought to this

phase of the business, they will immediately insist that the managers of their departments install a system of the nature of the one herewith indicated so that the department may, at

UPHOLDS FIXING OF PRICE

Jersey Court Says Manufacturer of Standard Article Has Right if Article Contains Notice

Fixing by the manufacturer of standard price for an article is legal. Vice-Chancellor Lane held in a decision in Newark recently in the suit of Robert H. Ingersoll & Bro. to restrain Hahne & Co., department store owners of Newark, from selling Ingersoll watches at less than the standard price without removing the trade name and manufacturer's guarantee. He held that the fixing of a standard price, if the article contained a notice of the conditions under which it might be sold by the retailer, was not a violation of the Sherman or Clayton Acts. He said the United States Supreme Court, in his opinion, had not passed on the "precise situation presented here." He conditionally took issue with a decision of ex-Justice Hughes on price-fixing.

"If the learned Justice meant that all restraints were void at common law, I think he was mistaken," the Vice-Chancellor stated. "But, be that as it may, it is now well settled that restraints which are reasonable, in the absence of the statute, are valid. It is also well recognized that a person has a property interest in his trade name and good-will, and will, even in the absence of the statute, be protected against injury to that trade name and good-will. This right has in this State been, as above indicated, recognized by statute."

The people who influence you are people who believe in you.—Drummond.

all times, serve your customers promptly with the records they want, and the dying out of the popularity of a record will find your stock at a minimum limit.

HEAVY FIRE LOSS IN CANTON, O.

Department Store of Klein & Heffelman Co. Wiped Out in \$1,500,000 Fire August 26—Company's Own Loss Fixed at \$250,000

CANTON, O., August 26.—Fire, which started shortly before 6 o'clock last night in the big store of the Klein & Heffelman Co., destroyed the business block bounded by Tuscarawas, East Second, Walnut and Piedmont streets, causing a loss estimated at \$1,500,000. The fire burned for nearly four hours before it was gotten under control. The Klein & Heffelman Co.'s loss is estimated at \$250,000, for their building with its contents was a complete loss. The company maintained for a number of years a large and successful piano and talking machine department, which, of course, was wiped out by the fire. It is expected that the company will secure temporary quarters until the former home can be rebuilt.

IDEAL MUSIC CO. CHANGES HANDS

POUGHKEEPSIE, N. Y., August 2.—The Ideal Music Co., located on Market street, was purchased this week by Luckey, Platt & Co., of this city. The entire stock of the concern will be moved to the Luckey, Platt & Co. store, a portion of which is being remodeled to receive the pianos and Victrolas formerly belonging to the Ideal Co.

Everett B. Koontz will shortly open a talking machine store on Jefferson avenue, Wheeling, W. Va.

A Word as to Trade Conditions

The ever increasing demand upon manufacturing facilities, and the supply of metal, due to the war, has caused an acute shortage both in production and stock.

In spite of this, the indications are that the demands of the trade will be abnormal during this fall and winter. In order that you may meet the requirements of your trade we would advise that you place your orders at once for early delivery.

Anticipating these conditions, we are prepared to make immediate shipments on all of our specialties.

The "BLISS" Reproducer, with its treated silk diaphragm, is the Reproducer De Luxe—have you heard it?

Other Phonograph Specialties that we are featuring are the "Disk-Lite," an electric lighting attachment adaptable to any phonograph, and the "Phono-Lite," an automatic lighting attachment for the New Edison, also Edison Diamond Points, Edison and Pathe Sapphire Points, Lakeside Rotometers, Johnson Electric Motors, B & H Fibre Needles, and B & H Fibre Needle Repointers.

Write for Our Parcel Post Salesman to Call

WILSON-LAIRD PHONOGRAPH CO., Inc.
Factors and Distributors of the BLISS REPRODUCER
29 West 34th Street NEW YORK CITY



The Scotford Tonearm And Superior Universal Reproducer

Perfect in acoustics—affording supreme quality and volume of tone

Handsomest and most distinctive in design and finish

The Reproducer that pivots on its axis, taking the correct angle for all makes of Records—and retains the same center in both positions—which feature, as shown below, is covered by United States Letters Patent, Number 1,251,828



Sample Prepaid
Nickel \$5.25 Gold \$6.50
If not rated—remit with order
Money refunded on return of Sample in good condition within 30 days

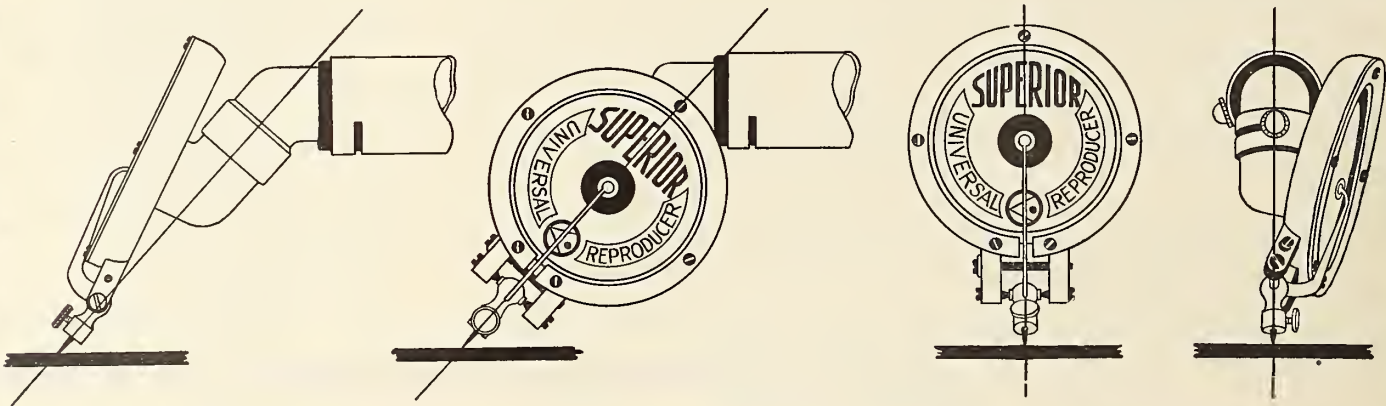

And this is but one of the Patented features which make it the Superior Universal

Mills & Cooper
Manufacturers of Mills Gramophones
2725 Calumet Avenue
Chicago

Barnhart Brothers & Spindler,
Chicago.

Sirs: We should like to have you share with us the enthusiasm that comes from hearing the Superior Reproducer at its best. We have completed our experimental work and have placed the Mills Gramophone on the market. As you know, we are using the Superior Reproducer and we consider it head and shoulders above anything made.

We have been experimenting for more than a year and have tried almost every combination under the sun. We like the Superior better than any other we tested and with it have been able to get probably the best reproduction ever attained.

It is only proper here to mention the intelligently rendered service which goes to users of your product. Your Mr. Louis K. Scotford has helped us immeasurably by his interest and suggestions. We have developed an amplifier which brings out the more subtle tones and gets the expression of the original with a character and musical ring we have never heard in another machine.

The Mills Gramophone is made in small quantity only for the higher class trade. It has made a profound impression among the music lovers who have heard it, and especially among those who do not care for the usual colorless phonographic results. It is absolutely toneless—that is it has no flavor of its own to mar the beauty of the original tones in the records. Our idea is that a phonograph has about as much business with tone as a cup has with flavor. With this idea in mind we have worked until we now have an instrument which will play every make of record better than the machines of the record manufacturers. The improvement is so marked in some cases as to be almost uncanny.

Respectfully, **Mills & Cooper.**
By G. K. Mills.

March 30, 1918

To Jobbers and Dealers in Edison, Pathe and Other Hill-and-Dale Records

You can greatly increase the demand for your Records by selling these Reproducers and Attachments applying them to various standard machines. Write for quantity prices Liberal Arrangement for Jobbers

The Superior Universal Reproducer

	Sample Prepaid	Retail Price
With Attachment for Victor	Nickel \$4.10 Gold 5.00	\$6.50 8.00
With Attachment for New Victor	Nickel 3.50 Gold 4.25	5.50 6.75
With Attachment for Columbia	Nickel 3.70 Gold 4.55	5.85 7.25
With Attachment for Edison	Nickel 4.10 Gold 5.00	6.50 8.00
With Attachment for Pathe	Nickel 3.70 Gold 4.40	5.85 7.00

*This refers to the latest type having the enlarged Tonearm

The Scotford Model I Reproducer

The original Scotford Reproducer—plays only Hill-and-Dale Records, but plays them at their best

	Sample Prepaid	Retail Price
As is—it fits the Victor	Nickel \$3.50 Gold 4.10	\$5.50 6.50
With Attachment for Columbia	Nickel 3.75 Gold 4.45	5.85 7.00
With Attachment for Pathe	Nickel 4.05 Gold 4.75	6.35 7.50

Can be used on the **Edison** with the Kent Attachment



Barnhart Brothers & Spindler Monroe and Throop Streets
Chicago
Makers of Superior Specialties for Phonographs

What the Self-starter is to the Automobile— the Columbia Non-Set Automatic Stop is to the Phonograph. And it's exclusively Columbia!

Columbia Graphophone Co.
NEW YORK



FEATURING GEN. PERSHING RECORDS

B. Lowenstein & Bros., Memphis, Get Excellent Results From Special Window Display

MEMPHIS, TENN., September 3.—B. Lowenstein & Bros., Inc., who maintain a large Columbia Grafonola department in their store here under the management of Jack Hofheinz, have been featuring the General Pershing records recently issued by the Columbia Co. with unusual success. The bulk of the sales of records is attributed to the elaborate window display recently arranged by the company, and which is illus-

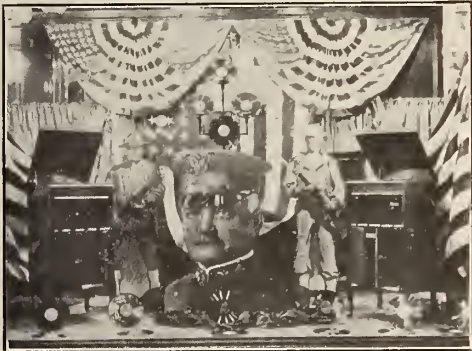

Lowenstein & Bros.' Pershing Window trated herewith. The display was arranged by the store's chief window decorator, T. J. Twentymen, with the assistance of Manager Hofheinz. A large figure of General Pershing was drawn and painted by Mr. Twentymen, as were the figures of the soldiers and sailors. The display not only featured the Pershing records, but also called attention to other hits through the medium of special posters.

Mr. Hofheinz, manager of the department, has met with considerable success here. He took charge about a year ago, coming from the Maison Blanche store in New Orleans. He is enthusiastic over fall prospects, and his chief worry is regarding a possible shortage of stock.

EDISON'S VIEWS ON RE-CREATION

Almost every member of the great Edison organization is familiar with the widely quoted statements made by Mr. Edison some months ago, which appeared in "The Etude," giving his views on the essentialness of music.

During the Edison dealers' convention in New York last June it was suggested that the company have an elocutionist make a Re-Creation of Mr. Edison's remarks. Sidney K. Powell has made such Re-Creation, and it is now available for Edison dealers at \$1 each.

There's time for everything—except the re-tailing of your uninteresting troubles.

COTTON FLOCKS

.. FOR ..

Record Manufacturing

THE PECKHAM MFG. CO., 238 South Street
NEWARK, N. J.

REPRESENTS B. & H. FIBRE NEEDLE

Wilson-Laird Phonograph Co. Appointed Eastern Jobber for the B. & H. Fibre Needle and Cutter—Also to Take On the Lakeside Rotometer and Johnson Electric Motor

H. T. Thornell, general manager of the Wilson-Laird Phonograph Co., New York, manufacturer of the "Bliss" reproducer, announced this week that the company has been appointed Eastern jobber for the B. & H. fibre needle cutter and the B. & H. fibre needle. These products have achieved remarkable success in all parts of the country, and Mr. Thornell is planning to institute an aggressive campaign that will give the dealers in the East an adequate idea of the unlimited sales possibilities for the cutter and the fibre needle.

Mr. Thornell has also completed arrangements whereby his company will act as jobber for the "Lakeside Rotometer," manufactured by the Lakeside Supply Co., Chicago, and the Johnson electric motor, manufactured by the Johnson

Electric Motor Co. of Chicago. Both of these products have won considerable praise from members of the trade, and the Wilson-Laird Phonograph Co. expects to feature them to excellent advantage in this territory this fall and winter.

Referring to his recent Western trip, Mr. Thornell stated that all the manufacturers and dealers whom he visited are enthusiastic regarding business possibilities, but are a little uncertain as to the likelihood of securing sufficient merchandise this coming fall to take care of the demands of their trade. Mr. Thornell believes that it will not be a matter of securing orders this fall, but a problem of securing sufficient merchandise.

Mr. Thornell states that the demand for the Bliss reproducer is far and beyond all expectations, and that the dealers are thoroughly satisfied with the service rendered by this reproducer. Many new accounts were opened on this trip, and there is every reason to believe that the Bliss reproducer will steadily increase in popularity this year.

THE PARR CENTRAL UNIVERSAL TONE-ARM

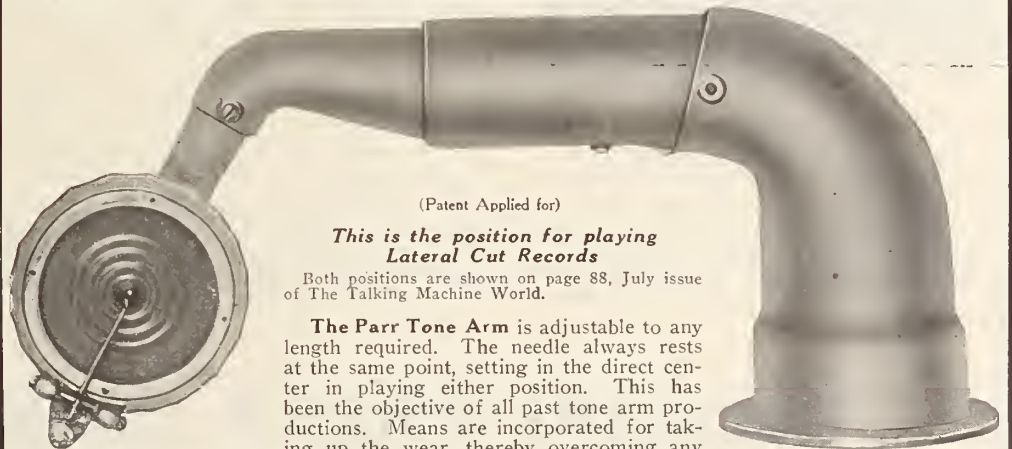

(Patent Applied for)

This is the position for playing Lateral Cut Records

Both positions are shown on page 88, July issue of The Talking Machine World.

The Parr Tone Arm is adjustable to any length required. The needle always rests at the same point, setting in the direct center in playing either position. This has been the objective of all past tone arm productions. Means are incorporated for taking up the wear, thereby overcoming any tendency for loose joints, which is the chief cause of "chattering."

The design of the tone arm permits perfect playing of either type of record without additional attachments. The sound box can be turned, allowing the needle to be changed with ease, and by a reverse movement the box returns to its normal playing position.

Parr Magnetic Reproducer fitted with the Vibratone Patent Diaphragm

The most sensitive of reproducers. The permanent magnetic device, an integral part of the reproducer, acts on the stylus box. Its possibilities in giving warmth and delicacy in the tonal reproduction of quiet passages make old-style sound boxes seem obsolete. And in fortissimo passages where ordinary reproducers create unpleasant, music destroying blasts, caused by the needle jumping and losing its grip, the Parr Magnetic Reproducer, with its marvelous flexibility, follows every wave and vibration in the record and takes everything the record holds.

The indestructible, non-crystallizing, always resilient Vibratone Patented Diaphragm

Possessing all the good points of mica diaphragms, it overcomes all mica's bad features. Guaranteed uniform in quality, free from bubbles, blisters and waves, the Vibratone Patented Diaphragm is non-porous, non-absorbent. It has a definite function and it performs it. It improves tone; in fact it creates new tone possibilities for every reproducer of other types.

PARR MANUFACTURING CORP.
ONE UNION SQUARE . . . NEW YORK



THE TRADE IN BOSTON AND NEW ENGLAND

JOHN H. WILSON, MANAGER, 324 WASHINGTON STREET, BOSTON, MASS.

BOSTON, MASS., September 4.—Now that the vacation season is practically over dealers are looking for a resumption of that halting activity that always obtains during the summer, always with the fact before them that there is a temporary barrier to good business which is not so much the fault of the dealers as of the manufacturers who are unable to supply the goods, and this in turn is not the fault of the manufacturers but because of a situation that all alike must face. Despite the general situation the sale in Boston, especially of records, has been good and everybody owning a machine seems bent on having all the war songs, and there are cases where it is not possible to fill the orders. Throughout Greater Boston outfits, rather expensive ones, too, have been installed in many homes in the past few weeks and these sales in most cases are directly traceable to a certain war prosperity. These sales do not come hard and they will be sought for with renewed vigor this fall.

T. W. Hindley New Vocalion Manager

Thomas W. Hindley, who was mentioned in this department last month as having joined the



Thomas W. Hindley

Vocalion forces in this city, is now occupying the post of manager, having succeeded R. S. Hibshman, who has been Boston manager for several years and who has now severed relations with the Aeolian-Vocalion Co. Mr. Hindley, of whom a picture is herewith given, comes from Providence and has some advanced

ideas as to the conduct of business in general which he purposes putting into operation in the interests of developing the Vocalion business. He is a man destined to make friends fast, and it is believed there is a new era ahead for the local business of the company in his hands.

Oscar W. Ray Enters New Field

There will be general regret at the departure of Oscar W. Ray, for some time manager of the Emerson Co. in this territory. Because of his ability in the field of efficiency management he has been invited by the foreign press bureau for manufacturing concerns to occupy a responsible post and he begins his new duties immediately. It is possible that he may be called upon to go with the Russian mission when it starts upon its propaganda campaign. Mr. Ray has made many friends in Boston and he has proved a valued man for the Emerson and into his campaign for business he has infused many original ideas, which dealers have eagerly subscribed to. H. L. Coombs, mentioned last month, succeeds Mr. Ray in the local management of the Emerson.

Souvenirs From Over There

Walter Gillis, manager of the Vocalion business in the Henry F. Miller Co.'s Boylston street warerooms, has been vacationizing at Cape Cod. A recent letter from his son, Walter Gillis, Jr., contained some souvenirs of a captured German, a set of epaulets, which, with some other adornments taken by another American, constituted about all that was left of the German, so Gillis wrote.

Oliver Ditson Co. Affairs

Business at the Victor department of the Oliver Ditson Co. moves along as well as a scarcity of goods will permit. Manager Winkelman with his limited staff is finding plenty to do, and outside of going back and forth to Acton he is not taking any extended vacation. Otto A. Piesendel, Mr. Winkelman's assistant, spent his vacation at Onset with his family and had fine weather all of the time.

Waiting for New Brunswick Models

As the new Brunswick models are daily looked for Manager F. H. Walter, of the Brunswick-Balke-Collender Co., has been unable to take his anticipated vacation, but later in the season he may find a little time for a rest from business duties. The new line of machines include those which are equipped with the new oval wood horn, which dealers say are going to be good

sellers. By way of making ready for these models Manager Walter has had the phonograph department considerably renovated so that it now is in every way better than ever before arranged to meet the demands of trade. Gus O'Connor, the Brunswick repair man, has left the house, having gone into service in the Merchant Marine, and in his place E. N. Moore, of Providence, has been engaged.

Something New in Apartment Furnishings

They say there is nothing new under the sun. This is possibly true, but your correspondent has found something new to him. It is the idea of building a phonographic outfit into an

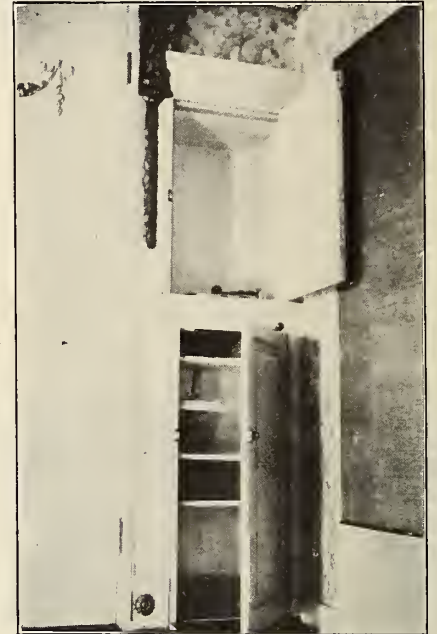

Phonographic Outfit in Apartment

apartment, making it a special feature of comfortable apartment house life. Herewith is a cut taken by the Boston representative of Musical America of a corner in a Brookline apartment wherein a Columbia outfit has been installed. One inserts the record in the upper closet while the sound emanates from the upper part of the under closet. While this is the first one installed it is planned by the owner of the block to put them in all his apartments.

Robert Steinert Enjoying Golf

Robert Steinert, head of the Arch street Victor headquarters of the M. Steinert & Sons Co.,

Behind the Co-operation

we are now extending in Eastern Victor Service lies the hope, that when the great world war has come to a victorious close we may look back on a period during which we attained a reputation among Victor dealers for giving practical help to them in the solution of their war-time problems.

EASTERN TALKING MACHINE CO.

177 TREMONT STREET

BOSTON, MASS.

Send for Descriptive Circular

Curry DEMONSTRATION BOOTHS
AND RECORD CASES
IN STOCK OR TO ORDER

"SOUND PROOF"

FRANK B. CURRY
19 Wareham St. Boston, Mass.

is spending much of his spare time these fine summer days on the golf links, and he is getting almost as proficient at the game as his distinguished father, Alexander Steinert. The Tedesco Club at Swampscott are the favorite links for Robert, who has a chance there to meet some able opponents. Wholesale Manager Kenneth Reed, of this house, has been up at Framingham training with the State Guard at Camp Augustus P. Gardiner. P. B. White, one of the floor salesmen, has returned from a two weeks' vacation spent at Wescott, Me. Business at this Victor headquarters is showing up well, but the dearth of machines is being keenly felt.

Wm. Fitzgerald Renews Energy Supply

William Fitzgerald, wholesale manager for the Eastern Talking Machine Co., has returned from his vacation spent at Camp 'Tis-Ours down on the coast of Maine and is finding enough to keep him on the jump, dividing his time between the Tremont street establishment and the company's storehouse. Elton C. Taft, son of Manager Taft, who went into service some time ago and has been at Hingham, is now at the radio school in Cambridge.

N. D. Griffin a Visitor

N. D. Griffin, of the American Phonograph Co., of Albany, N. Y., was able for a part of August to make the acquaintance of some of the local talking machine men, as he and his family were guests at the Pemberton Hotel, Hull. As Mr. Griffin was not in the best physical condition while here he was unable to accept much hospitality.

New Agencies for the Cheney

Ever since it was announced that the Cheney product was to push for recognition in this territory there has been a steady demand for literature from Herbert L. Royer besides many personal calls from dealers who were anxious to look into the merits of this fine machine. The result has been that Mr. Royer's Cheney headquarters at 77 Summer street have been well filled all of the time and his mail, too, has grown considerably. Within the past few weeks Mr. Royer has been successful in signing up a number of well-known concerns which will handle the Cheney line. Among them are the Timothy

The
CHENEY
PHONOGRAPH

"Plays all records better"

Dealers

are invited to inspect this instrument which is so distinctly different from all others.

Attractive agency proposition. Liberal advertising plans.

Write for catalog and full particulars

H. L. ROYER
New England Representative

77 SUMMER STREET, Room 59 - - BOSTON

Smith Co. in Roxbury, the C. E. Osgood Co. at the South End; the F. H. Thomas Co. in the Back Bay; C. C. Moir Co. in Cambridge; the Cushman Music Shop, Inc., of Hartford, Conn.; Knupfer & Dimmock, of Lawrence; John Z. Kelly, of Lynn; H. L. Cobb, of Stoughton; Caldwell Furniture Co., of Malden; Stoneham and Wakefield and Thomas Wardell, of Lowell.

Gets New Stock of Sonoras

Manager Richard Nelson, of the Sonora, has just got in a new stock of machines which are being eagerly sought by dealers in this product throughout Mr. Nelson's territory. It has proved a wise move to install the music rolls mentioned in last month's issue of *The World*, for dealers now have a good stock at a convenient headquarters so that the goods may be had at very short notice. A large consignment of these rolls has just been installed at the Sonora's new headquarters in Columbus avenue.

Developing Pathé Business

R. O. Ainslie, wholesale manager of the Pathé, has returned from his extended three weeks'

trip in the Middle West, during which he visited leading places in the States of Wisconsin, Illinois and Indiana. On his return he made stops at Sandusky, Cleveland and Syracuse, and everywhere he found the demand for Pathé outfits good. W. W. Radcliffe, who some time ago was with the Hallet & Davis Co., has renewed his association with this house and will give his exclusive time to the development of the Pathé business. He will be head of a specially created promotion department and will have a staff of women under him, these to go from town to town on a canvassing program. By the new system developed it is hoped to build the Pathé business, especially throughout New England, to large proportions. Three new Pathé dealers whom Manager Ainslie has lately signed up are E. B. Fox, of Waltham; A. A. Vose, of Framingham, and the Lenox Jewelry Co., of Boston and Brockton.

Chickering Manager Resigns

The Edison and Victor department of Chick-

(Continued on page 28)

**— Oldest and Largest
Manufacturers of Talking
Machine Needles in the
World—There are several reasons**

W. H. BAGSHAW CO., Lowell, Mass.

THE TRADE IN BOSTON AND NEW ENGLAND (Continued from page 27)

ering & Sons has lost its head man, as Manager Mason P. Currier has severed relations with the Chickering house. All the boys are now home from their vacations, and they are looking for a good fall business.

Fred E. Mann as a Pianist

When the Boston Rotary Club met at the Boston City Club a short time ago to give welcome to two distinguished British Rotarians who were on their way home from the Kansas City convention, Fred E. Mann, manager of the Columbia Co., was the pianist for the war songs sung at the beginning and through the luncheon; and there were many who discovered for the first time how good a pianist this modest Mann is.

C. J. Sylvester Enjoys Rest

Chester J. Sylvester, manager of the talking machine department of the C. E. Osgood Co., has been spending his fortnight's vacation in New Hampshire. His brother, Roy C. Sylvester, who for some time was with the Grafonola Co. of New England, is now manager for the C. C. Harvey Co.'s Lynn talking machine department.

George W. Hopkins a Visitor

George W. Hopkins, general sales manager of the Columbia Co., paid a flying visit to Boston a few weeks ago, and was here just long enough to say "hello" to the Columbia boys. N. P. Smith, of the general sales department, also was a local visitor, and R. W. Knox, of the advertising department, stopped over to renew acquaintances with the Columbia staff en route to his New York home from New Hampshire, where he had been spending his vacation.

Silliman Comments on Highways

Evidently Manager Fred Silliman, of Edison fame, has some opinion of Boston's highways, witness the following which was in a recent issue of the Boston Post: "Boston people do not begin to appreciate the magnificent highways for motor travel that exist in eastern Massachusetts," says Fred H. Silliman, of Chest-

nut Hill. "By taking a circular course or a series of figure eights it is possible to travel for from eighty to one hundred miles around Boston through delightful suburban country without even making the same trip a second time. In most big cities there are one or two good drives and that is all there is to it, but in Boston it is simply an endless chain of the most charming trips I have ever seen anywhere."

Mr. Silliman says he probably will not be able to get any vacation this summer, and besides he is so enjoying his new home that it is delightfully restful to remain right in Chestnut Hill.

J. F. Carr to Visit State Fairs

Manager J. F. Carr, of the dealers' service department of the Columbia, is away on a vacation, and with its conclusion it is his plan to go into Vermont and attend a number of the State fairs where the Columbia is to be featured, and develop a line of publicity on this line. Russ H. Luscomb, of the Columbia, has been rusticiating on a farm in New Hampshire.

A Vacation Auto Trip

Francis T. White, Edison and Victor manager at the C. C. Harvey Co., spent a pleasant vacation at New Found Lake, N. H., and as a part of his respite from business he took an auto trip among the White Mountains. Manager White has just added Miss Huerling to his staff of salespeople.

John Alsen in Hospital in France

Latest reports from John Alsen, of George Lincoln Parker's Victor and Edison departments, mentioned last month as having been injured at the front, are that he was gassed and has been in a hospital at Tours. Alsen is with the 101st Engineers, which has a large Boston contingent at the front.

H. R. Skelton Covers Large Field

A Boston visitor, whom the Edison dealers were glad to see, has been H. R. Skelton, of the Edison Co., who now has the large traveling

TALKING MACHINE DEALERS

—READ THIS—

"The finest and most delicate pieces of mechanism do not prove efficient unless properly lubricated. Skill, Genius, Invention and Workmanship must have the proper Oil. Stop and consider this when you have to buy an Oil for household use."

NYOIL

IS BEST

FOR ANY TALKING MACHINE



Being made in our Watch Oil Dep't, the same care given in refining as in our "Watch Oil," as all gums and impurities are extracted, leaving it Colorless, Odorless and Stainless.

BEWARE OF SCENTED OILS

Machines will not clog if oiled with NYOIL. NYOIL is used by the U. S. Gov't in Army and Navy. A trial order will make a permanent customer of you.

Ladies use NYOIL for Sewing Machines, for it is stainless.

Sportsmen find NYOIL best for Guns, for it keeps them from rusting.

NYOIL is put up in 1oz., 3 1/4 oz. and 8 oz. Bottles, and in Pint, Quart and Gallon Cans.

For Sale by all Talking Machine Supplies Dealers
WILLIAM F. NYE, New Bedford, Mass., U. S. A.

territory of New England, New York State and a part of New Jersey. He has just concluded a vacation which he spent with his family at his home at Nantasket. Mr. Skelton is not so frequent a Boston visitor as he used to be. He reports Edison business in his field as extremely good, and there has been a large sale of goods in anticipation of the increase of prices scheduled for September 1.

Harry C. Browne Enjoys Own Records

Harry C. Browne, of the "Oh, Lady! Lady!" Co., now playing at the Wilbur Theatre in this city, has been a frequent caller at the Columbia wholesale headquarters and he has enjoyed listening to some of his inimitable negro dialect records.

E. W. Keefe Makes a Change

The local trade learns that Everett W. Keefe, who was formerly with W. D. Wilmot, the dealer at Fall River, has gone over to New York, where he is associated with the Edison Shop in Fifth avenue. Mr. Keefe made the change a couple of weeks ago.

EDISON LINE FOR MEIKELJOHN

PROVIDENCE, R. I., September 4.—Meikeljohn Bros., of this city, who control two other successful shops at Pawtucket and Woonsocket, have just taken on the Edison line for their Providence and Pawtucket stores. These departments will be supervised by W. Wilbur Longfellow, who is well known in the trade and who for the past three years or more has been at the Pardee-Ellenberger Co.'s New Haven establishment, and before that was located in Boston, Mass.

HEADS ATHERTON CO. DEPARTMENT

BROCKTON, MASS., September 5.—The Atherton Furniture Co. has made a change in its personnel. Ralph Eaton, who formerly was the successful manager of the company's piano department, has turned his attention to the phonograph line and in the management of this department he is assisted by Mrs. Eaton, who has proved an adept at this line of business. A large stock of Edison goods has been installed, and William McDermott, who is familiar with the phonograph business, having been with Davis Brothers, of Plymouth, will be associated with Mr. and Mrs. Eaton. He has been provided with an automobile truck and will take care of the territory on the South Shore.

The Victory Phonograph Co., Inc., are preparing to open up a very handsome phonograph store in Atlanta, Ga., and have secured quarters in the Peachtree Arcade, a splendidly equipped building in that city.

Phonograph Dealers



Perfection Universal Tone Arm and Reproducer No. 6 set in position for playing "lateral" cut records.



Perfection Universal Tone Arm and Reproducer No. 6 set in position for playing "hill and dale" cut records.

One Tone Arm Plays All Records

THE PERFECTION UNIVERSAL TONE ARM No. 6 with new PUR-I-TONE reproducer attached will play any and all Makes of disc records, on EDISON DISC MACHINES. All records are reproduced without blast or extraneous sounds. The most valuable phonograph accessory manufactured in the world today. This arm and reproducer make the EDISON DISC the most perfect of all universal musical instruments. ORDER at once from your jobber, as no doubt he has a large quantity in stock. If he has not, write and we will supply you direct. We also have our new No. 5 arm ready for delivery. This arm plays only hill and dale records on Edison machines, and can be sold to owners of Edison machines who have our No. 4 tone arms, which play lateral cut records only. We also supply diamonds and sapphires in any quantity.

New England Talking Machine Co.

The Largest Manufacturers of Phonograph Accessories in the World

16-18 BEACH STREET

BOSTON, MASS.

New reproducers for playing ALL MAKES of hill and dale records on VICTOR, COLUMBIA and SONORA machines will be ready soon. Watch this space for announcement.

THE VALUE OF CO-OPERATION

How Morrison & Putnam, of Amsterdam, N. Y., Are Able to Continue Business Despite Serious Damage to Stock of Victrolas From Water

Not long ago Morrison & Putnam, of Amsterdam, N. Y., well-known Victor dealers, suffered quite a loss because of the breaking of a water pipe in their basement. As a direct result of this accident, practically their entire Victor machine stock was ruined.

As an example of co-operation and service to a high degree, it is interesting to note that by the following day Morrison & Putnam were in



View of Store After Water Damage

a position to continue their Victor business. This was occasioned by the joint work of the New York Talking Machine Co., Victor wholesalers, and several Victor dealers in metropolitan territory.

A few hours after the flood started, Morrison & Putnam called up the New York Talking Machine Co. by telephone, and explained the situation, expressing the hope that the company could let them have a few machines during the next few days. The New York Talking Machine Co., however, immediately started the "ball rolling" all along the line, and by nightfall of the same day had a full line of Victrolas en route to Amsterdam, N. Y. This was accomplished through the generosity and good-fellowship of the local Victor dealers, who, even though their

own stocks are abnormally short, gladly gave a machine or two to help a brother Victor dealer out of a serious predicament and their broad-minded attitude deserves high praise.

DEVELOPING EXPORT TRADE

Otto Heineman Phonograph Supply Co. Inaugurate Active Trade Campaign

In response to the encouraging attitude of the Government regarding the exporting of merchandise that is not made of raw materials which are classed as essential to the winning of the war, the Otto Heineman Phonograph Supply Co. has inaugurated an active campaign in behalf of its export trade. This campaign has proved remarkably successful, and R. C. Ackerman, manager of this department, has been working day and night in order to render efficient service to the Heineman export clientele.

In addition to using effective means of sales stimulation, the Otto Heineman Co. has conducted an educational campaign presenting the possibilities of export trade. In this connection it has sent out many letters featuring extracts from the New York Times and other well-known newspapers referring to the advisability of booming export trade during wartimes, particularly where the articles are not manufactured from materials considered essential for war purposes.

All of the Heineman products have been included in this export campaign, and Deen needles in particular have shared in this fast increasing trade. Prior to the war Germany exported billions of phonograph needles, but judging from the orders already received by the Otto Heineman Co. for Deen needles, practically all of this business has been diverted into American trade channels, and will remain here even when the war is over.

Be sure you know the difference between a fetlock and a forelock when you take time by the latter.

IN UNCLE SAM'S SERVICE

Leon Tobias, Now In the Navy, Recently Greeted His Many Friends In the Metropolitan District—In Training in Newport, R. I.

We take pleasure in presenting herewith a photograph of Leon Tobias, formerly traveling



Leon Tobias

representative for Arthur L. Van Veen & Co., New York, manufacturers of Van Veen "Bed-Set" booths. Mr. Tobias is now a member of Uncle Sam's "Jackies" in training at Newport, R. I., and judging from the enthusiastic spirit of the letters he has sent his friends in the trade, he is applying himself to his new work as diligently as he developed business for the Van Veen booths.

Mr. Tobias was a recent visitor to New York, calling upon some of the dealers and visiting the headquarters of A. L. Van Veen & Co. He expressed the belief that the boys in the U. S. Navy will be important factors in settling the disturbances abroad, and although he refused to state the actual date for his return, Mr. Tobias made several appointments with well-known dealers for the spring months in 1919.

No more graphite will be allowed to come into this country for the rest of the year, the War Trade Board rules. It has been found that stocks of graphite in this country, plus home production, will be sufficient to meet all demands until 1919.

The Leonard Markels BUTTERFLY MOTOR

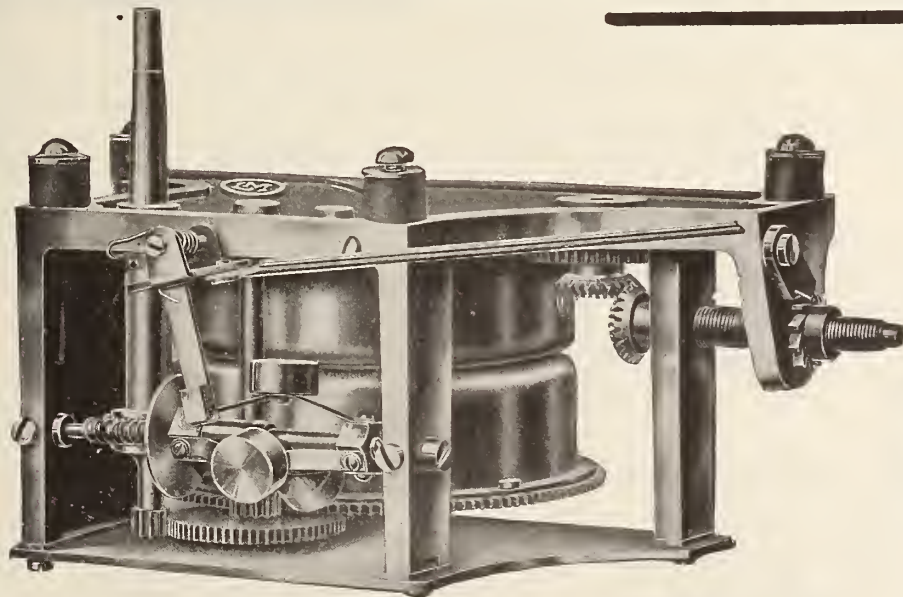

Specifications

- Beveled gear noiseless winding,
- New ratchet device that prevents clicking.
- Bakelite intermediate gear—absolutely silent.
- Plays seven 10-inch or five 12-inch records at one winding.
- Cast iron nickerled frame.
- Powerful, durable, compact, accessible.
- Built especially for the highest-grade machines.
- Guaranteed in every minutest detail.

The Leonard Markels Jewel Bearing Butterfly Motor

has revolutionized the motor industry. It is silent running and silent winding and represents the acme of perfection in motor construction.

This motor has achieved phenomenal success, and is being used exclusively by leading phonograph manufacturers in all parts of this country and Canada.

Write today for a copy of our New Butterfly folder

LEONARD MARKELS - 165 William St., New York



Tie up the beautiful new model Grafonolas with the Fall Furniture buying season. Feature them as perfect examples of well designed furniture!

**Columbia Graphophone Co.
NEW YORK**

OTTO HEINEMAN DENIES RUMORS

Otto Heineman Co. Has No Intention of Manufacturing Complete Machines—Will Continue Policy of Making Phonograph Parts Only

In an interview this week with a representative of The World, Otto Heineman, president of the Otto Heineman Phonograph Supply Co., New York, said: "I wish to deny absolutely the rumor that has been circulated in different trade centers, to the effect that this company will manufacture complete machines. We have never contemplated such a move, and have no idea of placing a complete machine on the market.

Otto Heineman

"This rumor is especially annoying at the present time, in view of the fact that we are endeavoring to co-operate with our clientele in the face of abnormal and discouraging conditions. We have left nothing undone to furnish our patrons with a necessary supply of motors, tone arms and sound boxes, and we certainly do not intend to compete with the manufacturers who have been so loyal to us during the past few years. We have restricted

our output in order to conform with the wishes of the Government, and I can state emphatically that the Otto Heineman Phonograph Supply Co. has absolutely no intention of placing a complete machine on the market."

TRADE MUST HUSBAND RESOURCES

Dealers Should Get Good Terms on Their Sales, Declares Lambert Friedl

In a chat this week with The World, Lambert Friedl, manager of the New York branch of the Columbia Graphophone Co., stated as follows: "I have a message for the Columbia dealers in this territory, which is becoming more timely day by day. I would urge them that in view of present manufacturing and transportation conditions, they husband their resources in every possible way, and not sell goods on ridiculous terms. There is no doubt but that there will be plenty of profitable business this fall for every Columbia dealer, and as the shortage of goods is certain to become worse month after month it behooves the dealers to sell their goods at a profit and not try to handle business on terms that are unprofitable.

"Our own business the past month has been excellent and has been limited only by the available supply of merchandise. The demand for Columbia products is far in advance of the supply, but we are doing our utmost to give our dealers the goods that they require."

INTERNATIONAL RECORD SECTION

Opened by Emerson Phonograph Co. of New York—Will Be Under the Management of Louis D. Rosenfield, Well Known in Trade

The Emerson Phonograph Co., New York, has advised Emerson dealers of the formation of a new department to be known as the international record department. This department is under



Louis D. Rosenfield

the management of Louis D. Rosenfield, formerly sales manager of the foreign-language record division of the Columbia Graphophone Co. Mr. Rosenfield, who is well known to the general talking machine trade, will be in complete charge of the manufacturing of Emerson nine-inch foreign records.

The first list of records produced by this department, which is now ready for distribution, presents selections which will doubtless meet with a ready sale in the Polish and Italian population of the country. Other languages, such as Russian, Ruthenian, Hebrew, Jewish, etc., will be announced very shortly; one nationality at a time.

Under the auspices of the new Emerson international record department there was recently introduced an interesting nine-inch Emerson record made by the Royal Serbian Tambouritza Orchestra. This orchestra, which appeared recently at the Waldorf-Astoria Hotel roof, New York, received a royal welcome from music-lovers and the tambouritza was the subject of many expressions of praise. This new Emerson record was recorded by the orchestra under the direction of Zerbes, a well-known conductor and violinist, who is very enthusiastic in his praises of the Emerson record made by his orchestra.

HAVE AEOLIAN-VOCALION LINE

Lansbrough & Bro., the well-known department store in Washington, D. C., is now handling the Aeolian-Vocalion, Geo. C. Maust, formerly in charge of the Grafonola department of Hecht & Co., being in charge, and reporting an excellent trade.

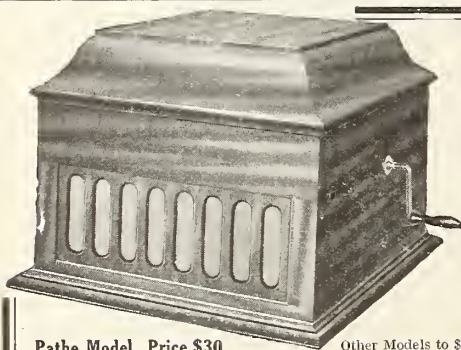

Pathe Model, Price \$30

Other Models to \$225.

- No Needles to Change**
The Pathe Sapphire Ball takes the place of needles. It need not be changed.
- Long Life to Records**
The Pathe Sapphire Ball cannot possibly cut, grind, rip or mar the record's surface.
- The Pathe Controls**
With the Pathe Controls you may increase or decrease the tonal volume of the Pathe Phonograph at will.
- Plays All Records**
Each Pathe Phonograph plays not only Pathe Records, but all other makes of disc records, and plays them perfectly.



Muratore—Exclusive Pathe Artist



Take the Three of Them

**Pathe Phonographs
Pathe Records
Fischer 24 Hour Service**

And you've got an unbeatable combination working to make money for you.

THE FISCHER COMPANY

Oldest Pathe Jobber

940 to 1040 Chestnut St., Cleveland, Ohio



Otto Heineman Phonograph Supply Co.

INCORPORATED

25 WEST 45th STREET, NEW YORK

FACTORIES, ELYRIA, O.—NEWARK, N. J.—PUTNAM, CONN.

CHICAGO

ATLANTA

SEATTLE

CINCINNATI

TORONTO



OKEH RECORDS

Music on both sides.
Sapphire or steel needle.
Popular and standard selections.

Full particulars regarding the distribution of this record will be given to any dealer or jobber upon application.

10 inches
in
Diameter



Hill-and-Dale
Cut

The first good Hill-and-Dale cut record, without a machine tied to it.
Notice how clear and distinct, how well rounded and true, the sound reproduction; yes, and the absence of scratching noises.

OKEHRECORDS our latest product, backed with our reputation, and unparalleled manufacturing facilities.

You will find your favorite artists, their voices ringing truer, and their instruments seeming more real. Write today for samples and prices.

Faithfully yours,

OTTO HEINEMAN PHONOGRAPH SUPPLY CO., Inc.

President

JOBBER'S

OKEHRECORDS are of special interest to you.
A remarkable proposition. Get in touch with us today.

OTTO HEINEMAN PHONOGRAPH SUPPLY CO., Inc.
25 West 45th Street,
New York.

Gentlemen:- I am interested in your record. Please put me on your mailing list.

Name.....
Street.....
City..... State.....

UNUSUAL VOCALION PUBLICITY

Plan of Featuring the Individual Artist and a Single Record Proves a Decided Success

Continuing its distinctive campaign featuring individual artists recording for the Vocalion



May Peterson

record library, the Aeolian Co. has been using in the local newspapers an artistic advertisement presenting a Vocalion record sung by Miss May

BUY WAR SAVINGS STAMPS REGULARLY

The Last Rose of Summer
sung by
MAY PETERSON
Prima Donna Soprano
of the
Metropolitan Opera

One of the New
VOCALION RECORDS

Advertising the Peterson Record

Peterson. As mentioned in last month's World, this advertising campaign is unusual in many

"The Music Without the Blur!"

This ideal of talking machine manufacture is attained more nearly than by any other, in the construction of the

MARVELOUS MAGNOLA
"Built by Tone Specialists"

"Magnola's Tone Deflector eliminates the scratch"



Watching the Music Come Out

We want to show you how to make money with MAGNOLA; and how MAGNOLA is the best buy on the Talking Machine Market to-day.

Send us your name and let us send you some real Talker Tips.

MAGNOLA TALKING MACHINE COMPANY

OTTO SCHULZ, President

General Offices Southern Wholesale Branch
711 MILWAUKEE AVENUE 1530 CANDLER BLDG.
CHICAGO ATLANTA, GA.

respects in the use of advertising concentrated on a single record and the individual artist. The results of this campaign to date indicate that this departure from the stereotyped form of advertising is a signal success.

Miss May Peterson, who will record exclusively for the Vocalion record library, is a young American soprano who has risen rapidly to fame in the operatic and concert field during her short but brilliant career. Miss Peterson made her debut in "Lakme" as prima donna soprano of the Paris Opera Comique. At the beginning of the war she returned to America for an extended concert tour and is, at the present time, singing important roles at the Metropolitan Opera House.

Miss Peterson's Vocalion record of "The Last Rose of Summer" has been praised by musical critics and experts as one of the finest renditions of this famous selection that has ever been presented to the music-loving public. The record has met with a ready sale throughout the country, and this advertising campaign is contributing materially to its success.

SERIES OF PROSPECT LETTERS

New York Talking Machine Co. Congratulated on Production of Trade-Stimulating Letters for Use of Their Retail Victor Dealers

The New York Talking Machine Co., Victor wholesaler, has received many letters from its dealers congratulating the company upon the production of its recent series of prospect letters. This series comprises six original and decidedly artistic letters that can be used to splendid advantage by the company's Victor dealers.

The letters are enclosed in a strikingly distinctive folder that features on its front cover the words "Plant a Stamp, and Raise a Customer." The illustration on the cover carries out this idea, and the use of a genuine stamp enhances the originality of the thought.

These six letters are entitled as follows: "Why music to-day more than ever?" "Half the people you know own a Victrola," "Not only for your pleasure, but for the children's good—you need a Victrola," "When you appreciate the Victrola most," "Why your choice should be the Victrola," "In your own home—without cost or without obligation."

The text of these letters carries out the appeal of the heading, and a distinctive illustration on each letter emphasizes the salient feature of each sales talk. At the bottom of each letter there is room for the dealer's imprint, and a remarkably striking border effect makes this letter 100 per cent. efficient from an art standpoint. The letters are offered to the dealers at nominal prices; 100 sets (six letters to each set) costing only \$6.75; 300 sets, \$15, and 500 sets \$22.50. This group of letters is the result of extended effort and expense to provide Victor dealers with effective selling arguments at this time of the year, and there is no doubt that the judicious use of this series of letters will enable the dealer to stimulate the demand for Victor products in his territory.

TWO NEW BRUNO WINDOW CARDS

C. Bruno & Son, Inc., New York, Victor wholesalers, have received a number of commendatory letters from Victor dealers in this territory, referring to the artistic conception of two new window cards recently issued by this house. These cards feature the popular hit from "Yip, Yip, Yaphank" entitled "Oh, How I Hate to Get Up in the Morning," and the successful ballad, "Dear Old Pal of Mine." The former is sung by Arthur Fields and the latter by John McCormack. The cards presenting these records are unusually attractive and can be used to excellent advantage by Victor dealers.

M. C. Conlin & Son, Victor dealers of Chicago, Ill., have occupied a handsome new store at 2322 West Madison street, that city, to be known as "Conlin's Talking Machine Shop."



No. 1410 Rim Table for Victrola IX or IXA Mahogany Holds 5 Victor Albums

Take the Buyer's Viewpoint

As a buyer you realize what a name means in inspiring confidence—in closing the sale.

Handle your Cabinet Customers from the Buyer's Viewpoint.

The UDELL Record and Music Roll Cabinets enjoy a nation-wide reputation for Supreme Quality and Dependability—backed by years of proof.

UDELL reputation will mean dollars of extra profit to you when you offer cabinets bearing that name to your trade.

And the designs are the work of artists—the sort that are bound to please.

Cabinets are going to figure prominently in this Fall's business.

Think it over Now.

A Catalog for the asking.

Watch for this Trade Mark.



TRADE MARK

1205 W. 28th St., INDIANAPOLIS, IND.

The most wonderful Talking Machine of the present age at the price
An Instrument of Supreme Value, Tone and Quality

Cleartone

SPEAKS FOR ITSELF



No. 100—\$100

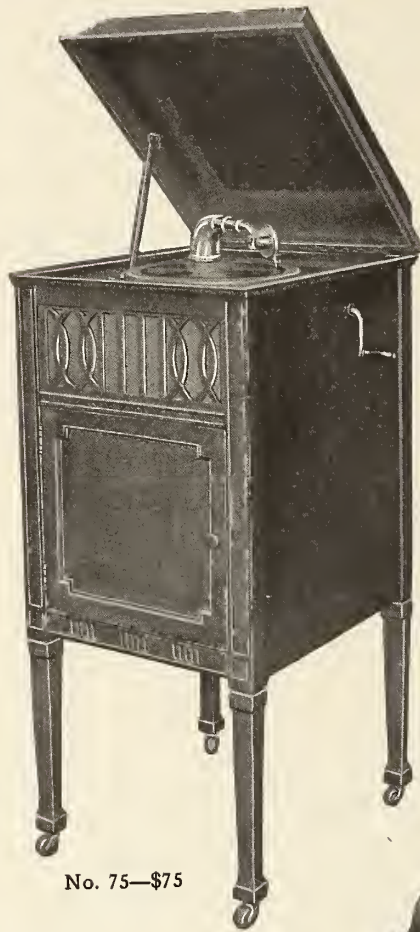

No. 75—\$75

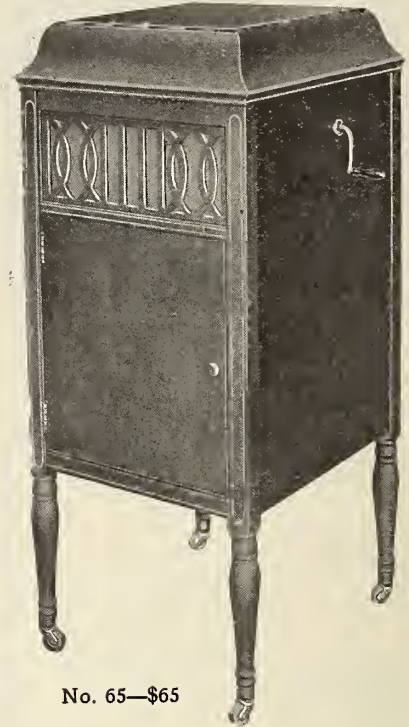

No. 65—\$65

The **Cleartone** has become very popular because of its quality, splendid value and the advertising and sales campaign that now stands in back of it. **Dealers!** Watch us grow—write for our agency and grow with us.

SUNDRY DEPARTMENT

MOTORS—No. 01, 8-in. turntable, single spring, \$1.45, same motor with 10-in. turntable, \$1.65. No. 1, 10-in. turntable, double spring, plays two 10-in. records, \$2.95. No. 6, 10-in. turntable, double spring, plays three 10-in. records, \$3.50; same motor with 12-in. turntable, \$3.85. No. 8, 12-in. turntable, cast-iron frame, double spring, plays three 10-in. records, \$4.85. No. 9, 12-in. turntable, cast-iron frame, bevel gear wind, double spring, plays three 10-in. records, \$5.85. No. 10, 12-in. turntable, cast-iron frame, bevel gear wind, double springs, plays four 10-in. records, \$6.85. No. 11, 12-in. turntable, cast-iron frame, bevel gear wind, double spring, plays seven 10-in. records, \$8.50.

TRAY ARMS AND REPRODUCERS—No. 1, \$1.10; No. 2, plays all records, \$1.35; No. 4, \$2.95; No. 6, \$2.75; No. 7, \$2.75; No. 8, \$2.75; No. 9, \$2.65. (Play all records.)

MAIN SPRINGS—No. 00— $\frac{1}{4}$ -in., 23 gauge, 9-6 ft., 29c. each, 100 lots, 25c. each; No. 01, 1-in., 23 gauge, 7 ft., 25c. each, 100 lots, 20c. each; No. 0, $\frac{3}{4}$ -in., 20 gauge, 8-6 ft., 25c. each, 100 lots, 21c. each; No. 1, $\frac{3}{4}$ -in., 25 gauge, 9-6 ft., 39c. each, 100 lots, 35c. each; No. 2, 1 $\frac{1}{2}$ -in., 25 gauge, 9-6 ft., 43c. each, 100 lots, 39c. each; No. 3, $\frac{7}{8}$ -in., 25 gauge, 11 ft., 49c. each, 100 lots, 45c. each; No. 4, 1-in., 23 gauge, 10 ft., 49c. each, 100 lots, 45c. each; No. 5, 1-in., 27 gauge, 11 ft., 65c. each, 100 lots, 59c. each; No. 6, 1 $\frac{1}{4}$ -in., 27 gauge, 11 ft., 90c. each, 100 lots, 85c. each.

RECORDS—POPULAR and GRAMMAVOX Brand, 10-

in. double face, lateral cut, all instrumental—32c. in lots of 100; 30c. in lots of 1,000; 29c. in lots of 5,000.

GOVERNOR SPRINGS—\$1.00 per hundred; \$6.00 per thousand. Special price in large quantities for Motor Manufacturers.

GENUINE DIAMOND POINTS for playing Edison Records, \$1.45 each, 100 lot, \$1.35 each; Sapphire Points for playing Edison Records, 18c. each, 100 lots, 14c. each; Sapphire Balls for playing Pathé Records, 18c. each, 100 lot 15c. each. **Needles**—Steel, 63c. per thousand in 10,000 lots, 59c. in 100,000 lots.

NEEDLE CUPS—\$17.50 per M. \$16.00 per M in 5,000 lots. Covers, \$7.50 per M.

COVER STAYS—No. 1, for Table Cabinets, 6 in. long, 9c. each, 100 lot, 7 $\frac{1}{2}$ c. each; No. 2, for Floor Cabinets, 9 in. long, 17c. each, 100 lot, 13c. each; No. 3, heavy for Floor Cabinets, 10 in. long, 20c. each, 100 lot, 16c. each.

Continuous Piano Hinges, 28c. per foot; 100 feet, 24c. per foot.

We also manufacture special machine parts, such as worm gears, stampings, or any screw machine parts for motor; reproducer and part manufacturers.

Special quotations given to quantity buyers in Canada and other export points.

Write for our 84-page catalog, the only one of its kind in America, illustrating 33 different styles of talking machines and over 500 different phonographic parts, also gives description of our efficient Repair Department.

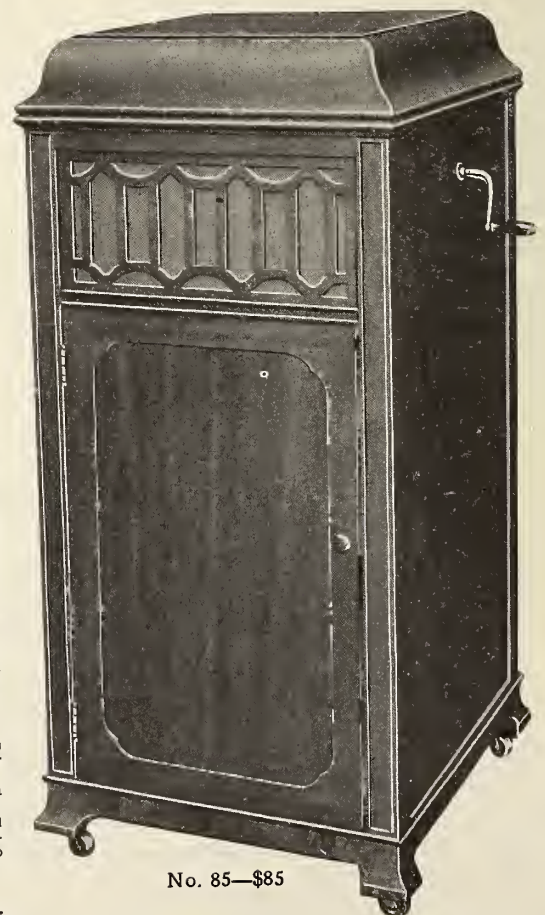

No. 85—\$85

Lucky 13 Phonograph Co., 3 East 12th St., New York

“A perfect voice!” exclaimed the veteran Head of the Reproducing Rooms, hearing Barbara Maurel—newest Columbia Star.

**Columbia Graphophone Co.
NEW YORK**



KANSAS CITY REPORTS BEST MONTH IN TRADE HISTORY

One House Reports Business 50 Per Cent. Ahead of August of Last Year—Dealers Optimistic, But Complain of Shortage of Machines and Records—Fall and Winter Outlook Gratifying

KANSAS CITY, Mo., September 4.—The month of August closes what has been an unusually good summer season in the talking machine business, according to local dealers. “This is the best August in the talking machine business we have ever experienced in the history of the store,” said D. B. Parsill, credit manager for the Wunderlich Piano Co., “and is fifty per cent. ahead of August, 1917. It is not a question of selling machines but of getting enough to supply the demand. We are anticipating an even more acute shortage as the fall and winter seasons come on.”

D. M. Guthrie, retail manager of the Columbia Grafonola Shop, has just returned from a fortnight’s motor trip through western Kansas and Colorado.

Business has been exceptionally good according to Mr. Guthrie, the only difficulty being the lack of merchandise. This shortage, however, has added materially to the cash business. The Pershing records continue to be exceptionally popular.

M. M. Blackman, manager of Edison wholesale, has left on a short business trip to Chicago. The firm reports that August has been one of the best months in a wholesale way that has been experienced since it went into business.

C. L. Smith, southeastern Kansas and eastern Oklahoma traveler for the Edison Co., out of the Kansas City office, has sailed for France. Harold Masters, formerly in the service department, is a member of the Signal Corps overseas.

The Architects and Engineers’ Supply Co. is preparing for its fall season and has secured a number of shipments of talking machines and records, according to Manager Clenny, of that department. E. B. Segerstrom, who has been associated with the piano business for a number of years in various capacities, is now with the talking machine department of the Architects and Engineers’ Supply Co.

A. A. Trostler, manager of the Victrola department of the Schmelzer Arms Co., leaves shortly on a trip to the factory at Camden, N. J., where he will attend a meeting of the executive board of the National Association of Talking Machine Jobbers, of which he is treasurer. From Camden Mr. Trostler will go to New York, Philadelphia and Washington, returning to Kansas City in about two weeks’ time.

Mr. Trostler states that business has been excellent, the only drawback being a scarcity of Victrolas. The shortage is expected to be more noticeable as the season advances.

Miss Brillings, who is in the wholesale Victrola department of Sanger Bros., Dallas, Tex., was in Kansas City for a short visit recently.

The Victrola department of the J. W. Jenkins’ Sons Music Co. is undergoing some in-

terior changes, made with the idea of increasing the efficiency of the service rendered. A new counter for accessories has been installed on the main floor and to take care of the record business in cases where the customer does not wish the record played. B. J. Pierce, manager, and his son, Willard, have recently returned from a short vacation and fishing trip spent near Pleasant Hill, Mo.

Mrs. Paul Oviatt, manager of the phonograph department of the Brunswick-Balke-Collender Co., wholesale, will leave shortly for a several weeks’ visit with her husband at Camp Funston, Kans.

A. J. Kendricks, general manager of the phonograph department of the Brunswick-Balke-Collender Co., Chicago, Ill., was in Kansas City recently on a tour of all the branches and dealers. Mr. Kendricks will leave shortly on a trip through Kansas.

W. P. Fishback, Brunswick dealer at Oak Grove, Mo., gave a concert with the machine at church services recently. This is a suggestion which should be valuable to many talking machine dealers in the smaller towns, for it is a delightful way of filling in the musical services at church Sunday evenings and bring about excellent results.

Glenn Ellison, Scotch baritone, is here giving

tone tests among the Edison dealers throughout the territory.

As proof of the assertion that August has been a record month in the wholesale Edison business, the following are a number of music dealers who have recently become representatives of the Edison Co.: C. L. Dosch, Maysville, Mo.; Bader’s Pharmacy, Canadian, Tex.; C. W. Williams, Pattonsburg, Mo.; the Corbin Drug Co., which has bought out I. E. Henry of Summerfield, Kans.; the Phillips Piano Co., Eldorado, Kans.; L. S. Grimur, Jewel City, Kans.; and the Music Emporium, Booneville, Mo., U. G. Smith, manager.

John Schaeffer, furniture dealer and Edison representative at Caldwell, Kans., is opening an Edison Shop at Anthony, Kans.

Fred Gennett, secretary of the Starr Piano Co., Richmond, Ind., was in Kansas City for a short visit to the local house. Word has just reached the Starr Piano Co. that C. V. Bissell, former manager, has arrived safely overseas.

Miss Surendorf, manager of the Starr Piano Co., reports that business has been holding up well in the talking machine business and showing heavy sales in the record department. “Everything is patriotic,” said Miss Surendorf, “and people will hardly listen to anything else. Our shipments have been coming through promptly and we find it a big item just now.”

P. R. Chapman, of the Phonograph Shop, Tulsa, Okla., spent his vacation this month in Chicago and Kansas City. Mr. Chapman was formerly with the Edison Shop here.

THIS ALBUM MADE US FAMOUS
by selling it. Why don't you try?

Pat. Dec. 15, 1914.

Buy Your Albums Direct From the Manufacturer

43-51 W. Fourth St.
New York, N. Y.

THE BOSTON BOOK CO., Inc.
The only exclusive Record Album Factory in the world.

Chicago Office:
1470 So. Michigan Ave.

STILL COMPLAIN OF STOCK SHORTAGE IN SAN FRANCISCO

Absence of Sufficient Stock to Meet Demands a Serious Setback to Business Growth—Dealers Hopeful That Requirements Will Be Met Later—Interesting Budget of News

SAN FRANCISCO, September 3.—According to reports from different talking machine distributors and dealers here, the situation in regard to stock shows no signs of improvement, and the outlook for the holiday season is far from bright, although there is still some hope that heavy shipments may be made to the Pacific Coast in the next few months, thus relieving the present shortage of machines to a considerable extent. The inability of the older manufacturers to meet the requirements of the trade is being taken full advantage of in this territory by some of the newer companies in placing their lines. By filling in with various makes the retailers in position to do so are making out somewhat better than the departments where one of the leading lines is handled exclusively.

Andrew G. McCarthy Reviews Situation

Andrew G. McCarthy, treasurer of Sherman, Clay & Co., who gives his personal attention to their Victor talking machine business, says they have no stock to sell wholesale, and don't know when they will be able to get more. Much the same condition prevails as far as their retail business is concerned. In fact, Mr. McCarthy says the stock situation is the worst it has ever been since they engaged in the talking machine business. Meanwhile Federal jury duty demands a good portion of Mr. McCarthy's time. He gets an hour or so, or half a day, off occasionally, but for several weeks he has been obliged to sit in court a good part of each week.

Columbia Demand On Increase

At the local warehouses of the Columbia Graphophone Co., Manager F. A. Denison says the amount of business done is controlled by the amount of stock received each week, the demand being greater than ever before for Columbia products in this territory, and the supply shorter. A number of dealers in this vicinity have stocked the company's foreign records re-

cently and from Mr. Denison's observations are doing very well with them. Wm. Pickering has been added to the Columbia sales force, covering northern California.

James J. Black Joins the Navy

James J. Black, treasurer of the Wiley B. Allen Co. and president of the San Francisco and Oakland Talking Machine Dealers' Association, has joined the colors. He donned the navy uniform and took up his new tasks on August 20. Being stationed in the Bay district, he still spends an hour at the store each evening. During the absence of Mr. Black, F. P. Corcoran, his able assistant for a number of years, has charge of the talking machine end of the Allen business.

Association Members Enjoy Outing

A very enjoyable outing was held early in August under the auspices of the San Francisco and Oakland Talking Machine Dealers' Association and the direct supervision of Wm. Norton, of Sherman, Clay & Co. The party, consisting of a hundred or more identified with the trade in the Bay section, their families and friends, assembled at Howard street wharf at 8:30 in the morning to board a large launch which had been chartered for the day. After cruising around the bay for three or four hours, with music and other forms of entertainment on board, a stop was made at Paradise Cove for lunch, including clam chowder, coffee, etc., made on the picnic grounds. When ravenous appetites were appeased, dancing ensued, and the afternoon was well along before the start was made on the homeward journey.

Talking Machine Man From India

Valabhdas Runchordas, head of the Talking Machine & Record Co. of Bombay, Calcutta, and Madras, India, and also of the general importing and distributing concern of Bombay, known as Valabhdas Runchordas & Co., has

ILSLEY'S GRAPHITE PHONO SPRING LUBRICANT

Ilseley's Lubricant makes the Motor make good
Is prepared in the proper consistency, will not run out, dry up, or become sticky or rancid. Remains in its original form indefinitely.
Write for special proposition to Jobbers.

MANUFACTURED BY
ILSLEY-DOUBLEDAY & CO., 229-231 Front St., New York
Established 1853

been spending some little time in San Francisco, after which he will proceed to New York and other Eastern cities for a stay of several months. The principal object of his trip to this country is to make connections with American manufacturers and distributors of various lines for handling their goods in India, replacing products received from Germany before the war.

Walter S. Gray Engages More Travelers

Walter S. Gray, jobber of talking machine needles and other trade accessories, recently put on two travelers in order to cover the Western territory more thoroughly. They are Mr. Sittenfeld, who will look after the southern part of California with headquarters in Los Angeles, and Mr. Altschuler, who will travel out of Seattle, Wash. Mr. Gray reports business well up to expectations, the demand for needles being unusually brisk. Shipments of Brilliantone needles are coming through very satisfactorily, he says.

C. T. Compton Back in the Fold

C. T. Compton, who left the Phonograph Shop a few weeks ago to engage in another line of business, has returned to his "first love," and claims to be glad to get back to selling talking machines and records.

Omer N. Kruschke, of the Western Phonograph Co., which distributes Pathé machines and records in California, Arizona and Nevada, says the principal difficulty nowadays is to get stock. At present his warehouses are practically cleaned out and future deliveries are uncertain.

Miss Dorothy Douglass a Bride

Miss Dorothy Douglass, daughter of Leon F. Douglass, of the Victor Talking Machine Co., became the bride of Joseph Trabucco, of San Francisco, who is now serving the United States as a naval aviator, in San Rafael, Cal., recently, the wedding being one of the most elaborate of the season. The ceremony was performed in the chapel of the Dominican Convent, where the bride was a former student. Earl Douglass, brother of the bride, was best man. Contrary to the regular order of things the groom's outfit attracted much attention. He was in full uniform, even to the wings, which symbol of the flying cadet he had just received. From the convent the guests were taken to the beautiful home of the Douglass family. Immediately after the wedding dinner and reception the young couple left for Akron, O., where Mr. Trabucco is stationed.

Mrs. Howard Features Pershing Record

Mrs. Helen Plummer Howard, manager of the talking machine department of the Hauschildt Music Co. in Oakland, Cal., announces that the company has added a stock of Columbia records to its line. She continues to extend her publicity work in new channels. Four times daily she has been giving an interesting talk at the Kinema Theatre, illustrating the Columbia record recorded by General Pershing on the battlefield of France. During the recent production of "Pershing's Crusaders" at one of the local picture theatres she co-operated not only with the Pershing record, but by sending a truck to the Bethlehem Shipbuilding Company's works, equipped with a talking machine playing patriotic airs, etc. It made a big hit.

JAZZ RECORDING BY FULLER'S BAND

The Emerson Phonograph Co. has called the attention of its dealers to the fact that its latest list features recordings by Earl Fuller's famous jazz band. This organization has achieved great success, and is generally recognized as the leading exponent of this popular class of music. The jazz numbers presented on the Emerson list are original compositions by Earl Fuller, and his band does ample justice to these interesting selections.

CABINETS that ARE DISTINCTIVE



Harponola

The first impression that is obtained of a talking machine is that part which is seen—the cabinet. If the cabinet appeals the sale is half made.

We have built into our cabinets our years of experience in fine furniture building. They have the distinction and pleasing lines of perfectly built furniture.

We have an interesting proposition for YOU whether you are a manufacturer, jobber or dealer. We will supply you with cabinets unequipped or equipped with the most modern accessories on the market. Write for detailed information.

Guaranteed and Manufactured by

THE CELINA FURNITURE CO.
CELINA, OHIO



UNICO

Designs and Construction
Patented

SYSTEM

THE SALES BUILDER

Unico Demonstrating Rooms
Excel from Every
Standpoint

- DESIGN Six standard styles
Special period styles
- CONSTRUCTION Patented, Interlocking
Portable Units
Sound Insulated
- FINISH All standard Oak,
Mahogany and Enamels
- EFFICIENCY Increased sales at lower
cost per sale
- ECONOMY Moderate first cost
Always an Asset
Adaptable any location
- DELIVERY Prompt shipments from
stock ready for im-
mediate use



Unico Racks and Counters
Maximum Capacity
Minimum Space

- DESIGN Patented to correspond
with Unico Rooms
- CONSTRUCTION Sectional Units adapta-
ble to any space
- FINISH All standard Oak, Ma-
hogany and Enamels
- EFFICIENCY All records always
available instantly
- ECONOMY Moderate Equipment
Cost
Lower Operating Cost
- DELIVERY Prompt shipments from
stock in all finishes

Install a
Complete Unico Department

- U** DEMONSTRATING ROOMS
- N** RECORD RACKS
- I** RECORD COUNTERS
- C** CEILING DECORATIONS
- O** ARCH TREATMENTS

The Unico System has
Increased Sales and Profits
for almost 1000 dealers



Send to-day dimensions of your available space. Plans and estimates for a complete department will reach you promptly

THE UNIT CONSTRUCTION COMPANY

RAYBURN CLARK SMITH, President

Fifty-eighth Street and Grays Avenue, PHILADELPHIA, U. S. A.

Happenings in Dominion of Canada

MANY CHANGES IN TALKING MACHINE TRADE IN TORONTO

Music Supply Co. Lease New Quarters—New Columbia Models Displayed—Phonola-Pollock Deal—New Post for R. C. Willis—E. S. Crawford Opens Up—New Home for "His Master's Voice," Ltd.

TORONTO, ONT., September 1.—Columbia dealers visiting Toronto during the exhibition will notice some very pleasing changes.

The Columbia Co. is now installed in the new factory building, with a capacity four times that of the old premises.

The Music Supply Co. (exclusive Columbia distributors) have leased the building next to their old location so that their new address is now 36 and 38 Wellington street East. They have fitted up very complete showrooms, with a display window to assist dealers in dressing windows; also demonstration booths, and all kinds of valuable sales-helpers. The Columbia period Grafonolas and other new models are on display at 36 and 38 Wellington street East; also at the exhibition grounds.

Both John A. Sabine and Charles R. Leake, proprietors of the Music Supply Co., will be in town during the Fair, and expect to meet many of their dealers.

These new models will be also on display in the Columbia tent at the exhibition grounds, where visiting dealers are invited to call. A limited quantity of the new models will be available during the next six weeks, but enough to let the various dealers get acquainted with the new motor, over which the Columbia people are very enthusiastic.

All details of the transaction have been completed whereby the phonograph business of the Pollock Mfg. Co., Ltd., is transferred to the Phonola Co. of Canada, Ltd. The latter firm is putting into immediate effect an aggressive business policy and proposes to materially enlarge the output of the Phonola Phonograph and the Phonola record.

At an early date the Pollock Mfg. Co., Ltd., anticipate announcing to the talking machine manufacturing industry of Canada their line of motors, tone arms, reproducers and other parts.

At the Flax Festival on the Ontario Government's farm, near Toronto, which was an important social function, a Sonora phonograph provided the music in the "five o'clock tea" booth.

R. C. Willis has resigned his position as manager of the Percival Piano Co. of Ottawa, and has connected himself with the Phonola Co. of Canada, Kitchener, for whom he will be wholesale representative of Phonolas and Phonola records.

R. L. Teeple, of the George McLagan Furniture Co.'s phonograph division, has returned from a successful trip through Western Canada. Mr. Teeple went through to British Columbia and was accorded a good reception for the McLagan phonograph.

Cecilian output, which was seriously interfered with by removing to the new factory, continues to improve, and J. E. Hoare, president of the Cecilian Co., Ltd., Toronto, is getting matters in more satisfactory shape to give customers better deliveries. Like all other manufacturers, Mr. Hoare is feeling the labor scarcity, which makes it impossible to get stock ahead in anticipation of fall.

Otis C. Dorian, general manager Pathé Freres Phonograph Co., has returned to Toronto from a business trip through Western Canada. Mr. Dorian visited Pathé dealers in the leading centers from Winnipeg to Vancouver. This was his initial tour of Western Canada, which in size, wealth of resources and enterprise of the people he found to be all that he had heard of it from other visitors.

The Pathé is handled by the Hudson's Bay Co. in Edmonton, Calgary, Lethridge, McLeod

and Vancouver, being the exclusive phonographic line in that corporation's Edmonton, Lethridge and McLeod stores.

As the result of his trip Mr. Dorian is more enthusiastic than ever over the business possibilities and opportunities that this country offers for the present generation as well as for future generations.

After many years' service with the firm of Heintzman & Co., six years as manager of the London branch, E. S. Crawford has tendered his resignation to enter into business for himself. Upon the occasion of his retiring the staff gathered around their popular manager and presented him with a beautiful Masonic ring, accompanied by an address. The entire staff have to part with a good friend, and the expressions of deep regret and also good will were sincerely evident. Mr. Crawford replied in feeling terms.

Mr. Crawford is entering the piano business with his father and brother. They will handle the Cecilian, Karn-Morris and Evans Bros. pianos, also Brunswick phonographs and records.

For many months the management of His Master's Voice, Ltd., have been anxiously awaiting the removal of the occupants of the building adjoining them and which they had leased. They have now secured possession and have moved in. This gives double the space occupied at 208 Adelaide street West, where the premises have been seriously cramped, to such dimensions has the business grown. The additional premises will permit the carrying of still a larger stock of Victor records needed to maintain the management's policy of one hundred per cent. deliveries of all orders.

The Grinyer Co., Ltd., Guelph, Ont., have taken on the Edison representation.

The McLaren Co., Ltd., St. Catharines, have broken into the phonograph business with a representative Edison department.

S. J. Pott, Canadian sales manager of the Otto Heineman Phonograph Supply & Music Co., Inc., paid a brief visit to his firm's head office in New York.

W. H. Alfring, manager of the wholesale Vocalion department of the Aeolian Co., New York, spent a day with the Nordheimer Piano

& Music Co., the Canadian distributors of the Vocalion.

H. Kautzman, road man with I. Montagnès & Co., distributors of the Sonora in Canada, has returned from a tour of Western Canada.

H. W. Wade, Columbia dealer, 935 Queen street East, proprietor of the River Dale Music Store, has retired from business and is spending the rest of the summer at his home at Frenchman's Bay. The Columbia agency for the Riverdale district has been taken over by Nelles Music Store, late of Danforth avenue, who have bought the property at 935 Queen street East.

Minerva Mfg. Co., Ltd., of Toronto, a newly incorporated firm, has been organized for the purpose of manufacturing the Sonora line of phonographs, of which I. Montagnès & Co. are the distributors in Canada. Of the new firm, E. H. van Gelder is president and I. Montagnès secretary-treasurer. The company's offices are in the new Ryrie Building, Yonge and Shuter streets.

A new style is being added to the Sonora range. This will be known as the "Harmony" model, and is a special design for the Canadian trade and manufactured in Canada. It has been decided that all Sonora models shall be made in this country.

In sending out a circular letter to the trade about period style Grafonolas, and describing them as the ultimate in musical instruments, James P. Bradt, general manager, said:

"While considering that magnificent display of Grafonolas, ranging in price from \$250 to \$2,100, let your mind wander back to the best that the talking machine industry could offer 25 years ago when all the business was in cylinder product and sales outfits averaged less than \$40. There was a near-sensation when a customer was landed for more than \$50. Get those pictures in your mind and your hand will start to lift your hat in recognition of the wonderful development of our enterprise."

The Columbia Co. has inaugurated new price designations for all types of Grafonolas. Types "A," "B," "C," and "D" are the table instruments listed at \$27 to \$80. Types "E" to "X" are full cabinet instruments and all of them will be equipped with the new motor and non-set automatic stop.

The company has begun to distribute samples of six new models of Grafonolas—all full cabinet instruments.

MONTREAL TRADE APPRECIATE VALUE OF WINDOW DISPLAY

Dealers Evidently in Competition With Each Other to Secure the Most Artistic Effects—Wins Favorable Notice of Public—Employees of Berliner Phonograph Co. Enjoy Outing—News of Month

MONTREAL, CAN., September 1.—One of the outstanding features in connection with local talking machine business is the development of the window display. There appears to be a competition amongst dealers, so noticeably improved are the windows of the various stores. The effects are so attractive that public comment is frequently heard and this is an asset to the trade at large. Now that the dealers realize

what an asset the window is in attracting public attention and approval, may the competition in window displays continue.

Wilder's Music Supply Co., Ltd., have enlarged their show window space in order to enable them to give more prominence to the display of their lines.

C. W. Lindsay, Ltd., recently sold a Sonora
(Continued on page 38)

Talking Machine Supplies and Repair Parts

SPRINGS, SOUND BOX PARTS, NEEDLES

THE RENÉ MANUFACTURING CO.
MONTVALE, NEW JERSEY

All Dealers May Now Sell Emerson Records

BY a decision of the United States Supreme Court, all dealers in zig-zag or lateral type records are permitted to handle other records of a similar nature.

This good news, already understood by an increasing number of progressive dealers, enables you to take on the very profitable line of the new large size Emerson records, including the patriotic popular song and dance hits released in advance of all other records.

They created the big new opportunity for supplying the increasing demand for a superior but lower priced record.

The New Large Size Records Are
65c
EACH

Just a Few of the Big Hits Now on Sale by Emerson Dealers:—



- 956 { On the Level You're A Little Devil . . . Eddie Nelson
- 956 { Where Have You Been Hiding All These Years . . . Eddie Nelson
- 960 { Smiles—Fox Trot . . . Emerson Military Band
- 960 { Since I Met Wonderful You—One Step, Emerson Military Band
- 970 { Oh! How I Hate to Get Up in the Morning . . . Eddie Nelson
- 970 { Our Country's In It Now, We've Got to Win It Now, Greek Evans
- 973 { Everything Is Peaches Down in Georgia . . . Sterling Trio
- 973 { The Sister of Rosie O'Grady . . . Frank Woods

And we can send you all the other big hits that you may want; tremendous sellers like:

- 940 If He Can Fight Like He Can Love
- 927 K-K-K-Katy
- 930 I'm Sorry I Made You Cry

FIRST OUT WITH THE BIG HITS

Emerson Phonograph Company INC.

3 West 35th Street - - New York City

The Emerson Phonograph Company

3 West 35th Street, New York

Gentlemen—

Kindly send me full details and particulars about your new large size Records at 65c each.

Name.....

Address.....

City.....



Sell Foreign Language Records. Small Investment—Big Turn-Over. Nationally Advertised—Service Guaranteed.

For Information, write to
International Record Dept.,
Columbia Graphophone Co.
102 West 38th St., New York

Columbia Graphophone Co.
NEW YORK

TRADE CONDITIONS IN THE DOMINION OF CANADA—(Continued from page 36)

portable machine to a Young Men's Club at Riviere des Prairie, Que., along with a well-selected library of records.

The Edison line is being given able representation by A. C. Skinner, of Sherbrooke, Que., who has just taken on these goods. He has to date sold a number of machines and records and is going after this business in the same manner which has characterized the success of his jewelry clientele.

Letters patent have been granted the Auditone Co., Ltd., who have incorporated at Montreal to deal in and manufacture talking machine records, etc., with a capital stock of \$20,000.

Layton Bros. report a heavy demand for Edison Creators Band records during the two weeks' visit of this band to Dominion Park.

The importance of music during wartime to help keep up spirits and morale has again been emphasized by the filling of an order for twenty-eight Columbia Grafonolas, Type A, by C. W. Lindsay, Ltd., for use aboard the Canadian patrol boats.

Employees and friends of the Berliner Gramophone Co., to the number of 1,140, were the guests of the company at a picnic on the steamer "Trois Rivieres" to Lavaltrie on a recent Saturday. The picnic marked the beginning of the annual fortnight of holidays given to the employees, with salary, the factory at St. Henry being closed down for the purpose.

Herbert S. Berliner, vice-president of the company, accompanied the picnickers, and during the afternoon festivities were marked by his presenting two gold watches, one to Leo Metivier, a seventeen-year-old lad who made 1,017 good 10-inch, double-sided records in ten hours, creating an average of 101.7 per hour. This record, which was made on March 13, 1918, was broken a week later by Marianna Rossi, who made 1,049 of the same sort of records in ten hours, an average of 104 per hour. Rossi was said to have broken the world's record.

Games and contests of various sorts served to enliven things during the afternoon, a great variety of prizes being offered to the winners of the events.

Among those present were R. L. Chilvers, general sales manager; S. Sanders, factory superintendent; George White, W. G. Davies, ad-

vertising manager; Fritz Hahn (Toronto), H. E. Wimperly (Toronto), E. Avery, S. H. Brown, J. McWilliam, purchasing agent (Toronto), and T. Nash.

Before reaching Montreal three hearty cheers were given for H. S. Berliner, and the Berliner Gramophone Co., through whose generosity such a large picnic had been successfully carried out.

The Phonograph Shop, Reg., of Montreal are

PROSPERITY RULES IN NEW ENGLAND

Great Activity in Manufacturing Lines Means Big Business for Merchants, Says Pardee

W. O. Pardee, of the Pardee-Ellenberger Co., large Edison jobber of New Haven, Conn., visited the Edison laboratories last week. He reports an unusually good summer among dealers in his territory.

Mr. Pardee gave a logical explanation of this condition. "Southern New England," he said, "is now enjoying unprecedented prosperity. This region is the center of huge manufacturing interests engaged in munitions work and other war orders. The laboring classes, particularly mechanics, have had an increase of salary frequently ranging from 100 to 200 per cent. above the normal amount these men have earned in former years."

The Pardee-Ellenberger Co. has arranged for an elaborate exhibit at the coming annual fair at Danbury, Conn., where it will have a tent seating 300 people and conduct a series of elaborate tone tests.

MAKE NICKEL-IN-SLOT PHONOGRAPH

The Electric Phonograph Co., of Kalamazoo, Mich., who recently rearranged the equipment of their new plant in that city, are now turning out a nickel-in-the-slot phonograph designed for public places. The machine is driven by electric motor and designed to play twenty-four tunes without change of records. John W. Adams is president and general manager of the business.

Truth in advertising is just as essential as truth in the news columns.

getting their full share of business and are making preparations for handling a large fall business in Pathé, Aeolian-Vocalion and Lyric machines. They report August trade as good with the demand confined principally to the better grade machines and sold to the better class of customers.

The Edwards Co., of Sherbrooke, Que., is meeting with good success with the Gerhard Heintzman phonograph.

INCREASING DEMAND FOR MICA

Great Quantity of This Material Used in This Country During the War

Sheet mica, which is used for diaphragms in the talking machine trade, has come to be an important war material through its use in electric apparatus, as well as for windows of armored cars and in the conning towers of war ships and submarines, and automobile goggles. The quantity of sheet mica produced and sold in the United States in 1917, according to experts of the United States Geological Survey, showed an increase of 41 per cent. over that sold in 1916, being 1,216,816 pounds, as compared with 865,863 pounds in 1916. No information is available to show what quantity of the domestic sheet mica produced would be suitable for any specific purpose, for the statistics include without distinction cut and uncut, clear, slightly spotted and stained, and heavily spotted and stained, as well as punch and washer mica. Sheet mica was produced in 1917 in eight States, which, grouped in the order of quantity produced, are North Carolina, New Hampshire, Virginia, South Dakota, Georgia, Alabama, Idaho and Colorado. North Carolina produced 48 per cent. of the total quantity; New Hampshire ranked second, with 39 per cent. It is said by the experts that the large producing States have done little more than hold their general average.

The prices paid for mica in 1917 continued with minor fluctuations to increase throughout the year. The prices paid for domestic mica in the South in 1917 were from 10 to 20 per cent. higher than the prices for similar mica in 1916. The greatest increase was in the price of smaller sizes. The largest sizes showed no increase in price.—Washington Star.

"MAGNET" DECALCOMANIE NAMEPLATES



SOLD BY
HURTEAU WILLIAMS & CO.
MONTREAL — OTTAWA



FOR TALKING MACHINE CABINETS ETC.

Pamphlets with fac-simile illustrations and prices mailed on request.

SMITH-SCHIFFLIN CO.

126 Liberty Street New York City



SOLD BY
WALTER D. MOSES & CO.
Oldest Music House in VA and N.C.
103 E. BRIDGEMAN STREET
RICHMOND, VA.

SOLD BY
J. E. STRATFORD
AUGUSTA, GA.

VICTOR SEPTEMBER SUPPLEMENT

The Victor record supplement for September, which has on the title page a bit of the garden scene from "Faust," also has as a feature, in addition to the interesting matter regarding the new records and the artists who make them, a special interview with Alma Gluck, handled in a most sprightly manner, and which should prove a strong attraction to the thousands of admirers of Mme. Gluck and her records.

The Empire Phono Parts Co., of Cleveland, O., has increased its capitalization from \$5,000 to \$10,000.

STRADIVARA

"KNOWN FOR TONE"

SEVEN MODELS TO RETAIL FROM \$60 TO \$250, WITH UNUSUAL TONE QUALITY AND EXQUISITE WORKMANSHIP. FULL ADVERTISING SERVICE, OF COURSE.

Manufactured by THE COMPTON-PRICE CO., COSHOCTON, O.



THE SUBTLE BEAUTIES OF ALL RECORDS ARE BROUGHT TO LIFE ONLY WHEN PLAYED ON THE STRADIVARA

THE TRADE OUTLOOK IN MILWAUKEE TERRITORY

Business Good Despite Stock Shortage—Talking Machine Jobbers and Dealers Discuss Situation—Month's News Tells Story of Progress

MILWAUKEE, Wis., September 7.—The spirit displayed by Milwaukee talking machine dealers in the face of difficulties that seem to grow in number and in the degree of restriction every day is a notable example of the splendid manner in which American business men are accepting every opportunity to serve the Government during its hour of greatest need. Every request which is promulgated because of a necessity growing out of the gigantic effort to win the war, and to win the war as quickly as possible, is meeting a quick and willing response from the talking machine trade, no matter what the cost may be.

Business during the last few weeks has been good, despite the fact that August is the real vacation month in this part of the country. Some dealers have been less fortunate than others in obtaining machines, records and supplies. Yet there is not a dealer who makes complaint, for everything that has been available has found a quick market. Cash sales have been the rule rather than the exception, and initial payments on deferred payment contracts have been larger than usual. At the same time, purchasers are more prompt in making time payments. Virtually the only drawback that can be generally noted is the inadequacy of stocks. This likewise causes some apprehension when the future is considered.

Although the shortage of machines and records has been the greatest concern of the Badger Talking Machine Co., Victor wholesaler, for several months past, its inability to get sufficient goods to supply the demands of its dealers has been accentuated during the last month. Harry A. Goldsmith, secretary of the company, sees little or no hope that production will broaden for some time to come; however, he reports that conditions in the trade are sound and doubtless will continue so.

Charles J. Orth, distributor of the Puritan phonograph and Paramount records in Wisconsin and Upper Michigan, is spending several weeks in the selection of a cottage on Crystal Lake, near Elkhart Lake, Wis., on the advice of physicians to get much-needed rest. Mr. Orth expects to return within a few days with his work for the remaining three and a half months of 1918 completely mapped out. This work embraces an extensive advertising campaign in behalf of the Puritan line, both from the jobber and retailer standpoint. Mr. Orth's publicity ideas are unique in the field and besides doing much of his own advertising, writing and planning, he constantly is urged by dealers to inject his personality into their own "copy," with the result that he never lacks for something to do. As the Puritan is made in Wisconsin, not far from Milwaukee, Mr. Orth has a sort of advantage over most jobbers in



PERSONAL SERVICE

The members of our Company are always available and will gladly see you personally or write you at any time we can possibly serve you.

Why not communicate at once with us?

BADGER TALKING-MACHINE CO. 135 Second Street
MILWAUKEE, WIS.
VICTOR DISTRIBUTORS

being able to make quick deliveries of goods.

The Brunswick continues to increase its prestige throughout Wisconsin, judging from the splendid volume of orders that are being received by Thomas I. Kidd, manager of the local branch of the Brunswick-Balke-Collender Co., 275-279 West Water street. Probably the greatest drawback at this time is the shortage of records, which is being experienced by all jobbers and retailers. Goods have been coming forward in good time, but the supply is by no means adequate, due to the constantly growing demand.

The Edison Shop, Edison jobber, finds the requirements of the trade larger than ever, in face of a supply that is dwindling rather than growing commensurately.

A. G. Kunde, a Columbia jobber and retailer, is one of the busiest talking machine men in Milwaukee, due to the enormous demand for Columbia records and machines as well. Columbia dealers some time ago heeded Mr. Kunde's warning to "get under cover" without delay and anticipate their wants for the fall and holiday season, but business has been so good that it has been almost impossible to accumulate stocks for future requirements.

The growing popularity of the Sonora, under the vigorous campaigning done by the Yahr & Lange Drug Co., is a feature of the trade. The Milwaukee house has been a distinct influence for improvement in the talking machine business by its strict adherence to the policy adopted some time ago, whereby practically all of the business is done on a cash basis and deferred or time payment business is discouraged.

The new Aeolian-Vocalion records have taken Wisconsin by storm and available supplies are far too small to meet the large demand which followed the announcement that the Aeolian Co., already famous for its instruments, would now furnish its own records. Miss Julia Wolf, manager of the Aeolian-Vocalion department of the Edmund Gram Music House, has been fairly swamped with orders for records.

Pathéphone machine and record business continues to grow by leaps and bounds and Milwaukee retailers meet much difficulty in obtaining adequate stocks. Pathé records have a splendid vogue in this territory, with a result that retailers are unable to keep their stocks in anywhere near the state of completeness demanded by their orders.

A notable contribution to the progress of community music has been made during the

last few months by Miss Helen Gunnis, manager of the Music Shop, retailing the Starr and Columbia. Miss Gunnis, as is well known, is a soprano of national reputation, and at the urgent request of the Milwaukee Board of Park Commissioners has given much of her time to singing at the free open-air park concerts during the nine weeks' season which ended August 31. In this period sixty-three concerts were given in seven of the largest parks, and the estimated aggregate attendance was 1,150,000. Community singing was introduced during the final months of the season and brought out crowds estimated as high as 30,000 at a single concert. Miss Gunnis has done much recording for Columbia and Aeolian-Vocalion records, and those who have heard these will realize why she has been in such great demand for public work.

"Jack" Stapleton, Watertown, Wis., formerly a well-known Edison traveler in Wisconsin, must now be addressed as "Lieutenant Stapleton." He won his shoulder straps in the aviation service at Kelly Field, Tex., and is now instructor at Camp Dix, N. J., but hopes soon to gratify his wish to go "over there."

The establishment of a permanent branch on the South Side of Milwaukee by the J. B. Bradford Piano Co. has given the Sonora an exceptionally high-class representation in this large and growing section of the city. This branch is located at 596 Mitchell street.

At the request of the State Fuel Administrator talking machine dealers have joined with other retail merchants throughout the city, numbering more than 2,900, in conserving fuel by closing at 6 p. m. on Monday, Tuesday, Wednesday and Thursday evenings. Inasmuch as all stores are closing, and none has any advantage over another, the request has met a general response, in spite of the fact that the volume of business doubtless is thereby restricted.

The Milwaukee Association of Music Industries is making good progress in its plan to organize a State association of talking machine, piano and other music merchants. Edmund Gram is chairman of the special committee and hopes to arrange a convention of dealers in Milwaukee some time in October, at which a State-wide organization is to be effected.

Meetings of the Milwaukee Association hereafter will not be strictly "stag" affairs, as they have been up to this time. Mrs. George H. Eichholz, widow of the Edison and Victor dealer who passed away recently, established a pleasing precedent by attending the regular monthly meeting in August as the guest of Frank Preuss, who is associated with her in the management of the Geo. H. Eichholz Co. Mrs. Eichholz was so pleased at the reception she received that she promised to bring other women members of the trade to the next meeting. Among these are Miss Helen Gunnis, manager of the Music Shop, and Mrs. Peter F. Piasecki, who is conducting the business while her husband, Colonel Piasecki, is serving with the Thirty-second Division in France.

P. RAY HAWLEY A BUSY MAN

ALBANY, N. Y., September 5.—P. Ray Hawley, familiarly referred to as "Inevitable Pete," is making an extensive tour in the interest of the Edison product for which he is a traveling manager. He is "Amberolizing" through the Adirondacks and the Catskills and also dating up tone tests on the side. Lately Hawley enjoyed a vacation at Little Meadows, Pa., where his mother resides.



AUTOMATIC STOPS

The simplest and most efficient Automatic Stop on the market. They give excellent service, are easily installed and are absolutely guaranteed.

Send 50 cents for Sample Stop

KIRKMAN ENGINEERING CORPORATION, 237 Lafayette St., New York

THE TRADE IN PHILADELPHIA AND LOCALITY

PHILADELPHIA, PA., September 4.—August was a very satisfactory month for the talking machine dealers of Philadelphia—that is, satisfactory in view of existing conditions. Dealers in most lines of instruments and records report very little improvement in the matter of delivery of stocks and naturally view the prospects for the fall and winter in this particular with no little concern. It is well known that several plants have been called upon by the Government to engage in war work to a greater or less extent, and although the manufacturers will endeavor to enlarge their working forces in order to keep up production in their regular lines, there are still prospects of a continued and more serious shortage.

More War Contracts for Victor Co.

It has just been announced that the Victor Co. has taken on a big Government contract for the making of rifle parts, and that 3,000 additional men will be employed in the Victor factory in connection with this work. It was rumored that the rifle contract amounted to \$18,000,000, but a Victor official states that, although the contract is for a big amount, it will not reach this figure. Plans are now under way to enlarge the Victor plant to care for this war work. For the past eight months the Victor Co. has been engaged in filling contracts for certain airplane parts, and an officer of the Victor Co. is quoted as saying: "Continuation of the work of manufacturing Victrolas and records is, of course, planned with the thought of caring for that business after the war, but just now the Victor Co.'s business is to help win the war."

Activity at Columbia Headquarters

A. J. Heath, the local manager for the Columbia Co., has just returned from a vacation of two weeks spent at the seashore. He enjoyed the much-needed rest after a very strenuous year. He states: "I find, in looking over results, that business was exceptionally good last month, especially our record sales, but our business would have been far greater if we had been able to secure a needed and sufficient supply of Grafonolas."

H. E. Gardiner has been made assistant manager of the Philadelphia Columbia headquar-

TALKING MACHINE DEALERS

can greatly increase their profits without additional overhead expense, by selling the world-famous

Weymann "KEYSTONE STATE" Musical Instruments

a combination that has proved to be an instantaneous success.

Write for catalogue

H. A. WEYMANN & SON

Manufacturers

**Victor
Wholesalers**

**1108 Chestnut St.
Philadelphia, Pa.**

Established 1864

ters. Mr. Gardiner was, for a time, connected with the general sales department of the Columbia in New York. With his broad experience, both in this line and other lines, it will mean an additional improvement to the Columbia retailers in the service during the coming months.

Charles R. Lamm, who was in charge of the trade and promotion department of the Columbia, has been called to the colors. He is now in one of the camps in Georgia. A. Rogers, who recently enlisted, is now in France. W. A. Quinnt, also a former Columbia man, is now on one of the cruising patrol boats in the waters off the coast of France.

Good August for Buehn Co.

Louis Buehn, of the Louis Buehn Co., reports that his business was satisfactory in August, considering conditions generally. He will bring his family home from their Ocean City cottage at the end of the week. Mr. Buehn has been elected Rear Commodore of the Ocean City Yacht Club, and he is generally saluted on the boardwalk as "Commodore."

A. L. Henricks, 3548 North Seventeenth street, has sold his business to H. B. Dunlevy, Fifty-eighth street and Willows avenue, who will continue it.

Weymann Men in the Service

H. W. Weymann notes that the Victor business of his firm has been satisfactory, but they have been seriously handicapped in the loss of valuable men who have gone into the Government service. William Wendt and A. Hyde, both from the wholesale Victor department, have recently been called and were sent to the camp. Julius Zendell, from the Victor repair department, has also gone with the draft, as has J. De Angelo, of the office force.

Thomas Cummings in France

Thomas Cummings, of the Victor department of Strawbridge & Clothier, has been heard from as having arrived safely in France, as well as Paul Henninger, and William Freeman, who has been abroad for some time, writes that he has met with an accident but is recovering. Lytle Graham, of the same department, has just paid the store his last visit, and is now on his way to France.

A. W. Loser, of the Miller Music Co., of Lebanon, Pa., has been in Philadelphia and announces that he is having eight new booths installed in his store.

Test Victor-Built Airplane

Employees of the Victor Talking Machine Co. factory last week saw a highly successful demonstration of one of the new airplanes built by that concern for the Government. Officials of the company viewed the flight from the roof of the executive offices and were delighted with the complete success of the exhibition.

With Lieutenant H. A. Pumpelly at the wheel, the plane came up from League Island, followed the course of the river and flew over the buildings of the Victor Co. It then encircled

The Latch String Hangs Out

WE ARE NOW at home in our New Quarters at 913 Arch Street, where we will be glad to welcome visiting dealers. Come and see us.

Increased facilities make possible more efficient Penn Service.

Penn Phonograph Co., Inc.

913 ARCH STREET PHILADELPHIA

Wholesale Only

BU EHN Service on Victor Records PHILADELPHIA

CUNNINGHAM sells twice as many Victrolas and Victor Records as Holmes—both the same age and equivalent years of experience. Why is this? Simply because Cunningham would rather sell than eat; selling goods is sport to him, for a sportsmanship spirit enters into every sale. He likes to meet "arguments"; he delights in proving that in this age music is the chief recreation and a most necessary part of the home's happiness. Enthusiasm carries the sale over.

For September, call on two more people a day than your regular number. Work with Cunningham's enthusiasm, and you'll get a big increase. Specialize on the higher-priced, better-music Records.

THE LOUIS BUEHN CO., PHILADELPHIA

Petty's Island and speeded back to the Navy Yard. The craft was fitted with a Liberty motor, which was the only part of the machine not constructed at the Victor plant, which has a \$15,000,000 contract for the construction of airplanes.

Meeting of Edison Dealers

The regular monthly meeting of the Edison dealers in Philadelphia was held at the Blake & Burkart warerooms on Tuesday of this week. They all told of wonderful figures for the month of August. Some of the results for the month would almost seem incredible. Next month the association will have its annual banquet.

Mr. Blake states that he was able to get all the goods he needed, and that he had the biggest August he has ever had, the biggest month he has ever had outside of December, and much bigger than any November in the past. He says that if they will be able to get the goods the Edison dealers are going to have a very profitable fall.

H. C. Trader, a Blake & Burkart representative, is spending several days this week in New York seeing what he can pick up for the advantage of the firm.

Report Good August Business

G. M. Austin, the Philadelphia representative of the Ediphonc, was in New York for a few days and then spent the rest of his vacation in southern Maryland. He reports that business in August was very good—in fact, it has been very good all through the year. His firm has been supplying large quantities of machines to the Government plants here, and is anticipating

a very active fall, both in these works and among the firms in other lines.

Mr. Dexheimer, a representative of the Edison Co., has been here for a couple of days.

Announce Price Increase

H. A. Weymann & Son, Victor wholesalers, Philadelphia, Pa., are sending an announcement to their dealers of the necessary price increase of the "Keystone State" line of musical instruments which they produce. This advance is caused by the increased cost of raw materials together with the increased labor cost. All orders are being impartially filled in the order they are received, and dealers are asked in the letter to anticipate their requirements as far in advance as possible for their own protection.

Penn Phonograph Co. in New Home

The Penn Phonograph Co. are now settled in their new home at 913 Arch street, details of which will be found in another section of The World. Stock shortage represents one of

the problems of the Penn Co., and the company also finds its organization seriously impaired by the working of the "work or fight" order of the new draft. They have already lost six men, and contemplate withdrawing all traveling men from the various territories, soliciting business entirely by correspondence. The travelers will call on dealers to handle matters requiring special attention.

H. F. Miller, of the Penn Co., has just returned from a two weeks' vacation trip. He went from here to Niagara Falls in his car, and then by way of the Thousand Islands to the Champlain and George Lake section, and home. T. W. Barnhill also recently made a vacation trip to Lake George and by way of the Berkshires and the Water Gap home.

Moving to Latrobe, Pa.

The offices and factory of the Domestic Talking Machine Co. are being moved from Philadelphia to Latrobe, Pa.

AN INTERESTING ISSUE

Latest "Columbia Record" Contains Many Articles of Interest to the Trade

The September issue of the "Columbia Record," the house organ published by the Columbia Graphophone Co., was mailed to Columbia dealers this week, and this issue contains many timely items that will undoubtedly be read with keen interest by Columbia representatives.

One article calls attention to an unusual stunt evolved by S. Hamilton & Co., Pittsburgh, to stimulate the demand for a comic record. This stunt was a signal success, and produced many sales of the record featured. Another article presents an illustration of a scene from a recent photoplay, "The Rescue," in which a Grafonola plays a prominent part. There are other interesting photographs in this issue of the "Columbia Record," indicating the popularity of Columbia products throughout the country.

Two columns are devoted to an article on "Musical Menus," a booklet published some time

ago by the Columbia Graphophone Co., which is meeting with considerable favor in the trade. This article emphasizes the value of this booklet to the dealer, calling attention to the different uses to which it can be adapted. There are the usual suggestions regarding Columbia publicity, and the reproduction of a splendid advertisement featuring the coming Fourth Liberty Loan.

The Muehlhauser Bros. Co., the prominent music house of Cleveland, O., is the latest concern in that city to take on the Pathé line of machines and records.

SHELTON ELECTRIC PHONOGRAPH MOTOR

We have increased our factory facilities to handle the demand for the Shelton Electric Motor, and are now ready to make prompt deliveries.

Write for our Special Agency Proposition

SHELTON ELECTRIC CO.
30 East 42nd Street, NEW YORK

"NICHOLSON" New Catalog Showing New Styles RECORD CABINETS

strictly high-grade construction at prices
BELOW COMPETITION

Write for a copy of the catalog and our
special free advertising help for dealers.

K. NICHOLSON FURNITURE CO., Chase City, Virginia
Sectional Bookcases and Record Cabinets

Three Big Values—Three Big Sellers

Model No. 3
\$125.00



Model No. 6
\$90.00



Model No. 5.
\$65.00

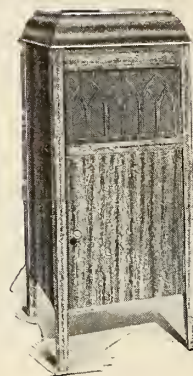

MANDEL PHONOGRAPHS—made by one maker—backed to the limit by the manufacturer, means a service that guarantees your success.

The MANDEL embodies massiveness in cabinet design, efficiency in mechanical construction and richness in tonal quality. These three factors are the making of a good talking machine. And the MANDEL is a good machine.

The three models here illustrated are producing big results for MANDEL dealers. Three popular-priced phonographs — each model giving the consumer greater value for his money than he could ordinarily obtain.

And to the dealer we offer a wonderfully attractive proposition—a co-operative plan that makes it pay him to sell MANDEL Phonographs.

Write for full details—today

A Letter from Missouri—Name and Address on Request

MANDEL MFG. CO.,
Chicago, Ill.

Gentlemen:

Please book my order for immediate shipment by freight, the following:

Two Style No. 3 MANDEL Phonographs, Oak finish.

Two Style No. 3 MANDEL Phonographs, Mahogany finish.

Each purchaser of the MANDEL is delighted with the rich tone value and each sale draws more sales. I sold the last MANDEL today, so please rush out this shipment. I want to keep the MANDEL on my floor. (A MANDEL DEALER)

MANDEL MANUFACTURING CO.

501-511 So. Laflin Street, Chicago, Illinois

INCREASED PURCHASING POWER EVIDENT IN ST. LOUIS

Prosperity of the Working Classes Big Factor in Sales of Talking Machines—Revenue Tax and Selling Cost—Silverstone Tone Test Demonstrations—Big Vocalion Demand—News of Month

St. LOUIS, Mo., September 9.—Ask any St. Louis talking machine dealer about business and he will answer by telling you of his supply of machines. The inference is, and by questioning you will find that this is what he means, that he is selling practically all of the machines he can get. Of course, he has on hand some machines, but these represent the unexpended selling energy that he is keeping in reserve.

It is a fact that the talking machine business is going forward just now with less expense and push than ever before, and that under present conditions a great many dealers are taking in more money than ever before. Of course, their main lines of machines are short of the orders they have on file and of the possibilities in selling. But usually a dealer has as a sideline a lesser known machine that he is receiving in fair quantities and he is selling these in larger quantity than ever before.

The World correspondent has not yet talked with any dealer who believed that he had in sight a Christmas stock. All are living in hope that some of the orders they have on file will be filled, but at the same time they are in doubt that such will be the case. The trade generally has arrived at the conclusion that further restrictions on supply are to be expected and must be accepted in as cheerful spirit as possible. As a rule the dealers do not seriously object to an increased selling price, due to new revenue tax. They look upon this as a part of war conditions and they do not believe that such a tax will work a great hardship on selling, but that the condition will be that most buyers will buy anyhow but will take a machine perhaps a size less than they would have bought without the tax. The customers, most of them, are receiving increased wages because of the war, so they are not objecting to taxes. In fact, a great many of the present-day customers practically admit that they are buying solely because of conditions brought to them because of the war and, whatever the cost may be, they are that much above former conditions.

Manager Guttenberg, of the Vocalion department at Aeolian Hall, reports a unique condition as regards the local situation. He says that in the two months since the end of the fiscal year of the local branch the talking machine department has showed an increase of more than 200 and 300 per cent. His supply of machines has never been quite up to selling capacity, but it has been ample to meet the demands from day to day.

During August Mr. Guttenberg made a vacation trip to the Gulf Coast, and while there made a few side trips to inquire into the talking machine business in the various centers. He found that in the cities most favored by war industries the business was running away from all expectations. These towns include Mobile, where the shipyards are sending the population figures up by jumps, and in Birmingham, where the iron industry is expanding to meet the war demands. In New Orleans, where there is little special industry, he found that trade is good, but the population is depleted because of wage attractions of nearby cities.

The jobbing business, Mr. Guttenberg says, is all that could be asked. He does not find it necessary to push the Vocalion on any one, but a town is carefully sized up and then the local representation is offered to the desirable store and it is quickly snapped up. No experiments are being made.

Acting Manager Roos, of the Columbia Co., who was transferred here from Cleveland about the first of August, is now settled in his new place and is getting acquainted with his trade. He returned from a trip to Cleveland the first of September, having completed his business there and moving his family to St. Louis. During August he spent most of his time getting things to running his way and in seeing just how the branch stood. He had received sev-

eral very good shipments and the distribution of these placed his territory in better condition to meet the extraordinary demands for machines. The record business, it was said at the Columbia branch, is running beyond all expectations, but that deliveries were being made in very fair proportion and on a basis that is much more encouraging to dealers than that which prevailed earlier in the season.

The Silverstone Music Co. has completed arrangements for a long series of tone test demonstrations in St. Louis and their trade district. Victor Dalhart will be in St. Louis and will spend considerable time in this section. Mark Silverstone, president of the company, returned the first of the month from a trip to the Pacific Coast that began with the World Advertising convention in San Francisco two months ago. He has since been visiting the noted spots and enjoying himself.

General Manager Goldberg, of the Silverstone Co., announced the arrival of a son during August.

Gus Hanschen, manager of the talking machine department of the Vandervoort Music Salon, enlisted in the engineering department of the army recently. Mr. Hanschen is a graduate engineer, but had never followed that busi-

ness. After he left school he continued his music studies, and before he entered the talking machine business he was locally famous as an exponent of ragtime music and he managed and led an orchestra that was extremely popular during the dancing revival. For the last two years his orchestra supplied music for the open air dances given by the city in the parks.

J. B. Sabbath, manager of the talking machine department of the Kieselhorst Music Co., left late in August for a motor trip to Sandusky, O., and other points of interest in that section.

Manager Stafflebach, of the Hellrung & Grimm Pathé department, has been making a series of trips into his jobbing territory to see that the dealers understood the present business conditions. He says that it is not a question of selling machines or of obtaining dealers, for both can be accomplished beyond capacity of stock available, but rather he is seeking to put his territory on the most dependable basis for the period of the war so that he may be ready to go ahead with confidence and little need of driving when restrictions are lifted.

KEEP TAB ON YOUR COMPETITORS

"In business watch your competitors. No one man or concern has a monopoly of all the best brains and methods. Let competition be an incentive to your energy and ambition. Give the other fellow a fair, square deal and beat him out on your merits."—Walter H. Cottingham.



William and Mary Period Model

Delpheon
the
Incomparable

¶ A truly unusual instrument for those not content with the ordinary

THE DELPHEON COMPANY
BAY CITY :: :: MICHIGAN

Or Write to Distributors

NEW WINDOW DISPLAYS FOR EDISON DEALERS

Four Elaborate Window Displays Designed by Ellis Hansen Now Ready for Distribution—New Displays Each Month at Nominal Cost

Thomas A. Edison, Inc., announce that they are now prepared to furnish to their dealers four elaborate window displays prepared by Ellis Hansen, the well-known expert in that line, and which were shown for the first time at the Edison dealers' convention held in New York last June. The Edison interests have always considered artistic window displays as most important adjuncts to the national advertising campaign and have encouraged both jobbers and dealers to give this matter their attention. In securing the services of Mr. Hansen for designing and arranging special window displays, the company are able to place at the service of the dealer, at nominal cost, window displays that would prove beyond his means were he to have them designed and arranged for his exclusive use.

Ellis Hansen has a national reputation as one of the leading window display men of the country, with a special ability for handling phonograph displays. Not only has his work been commented on in all of the prominent music



Cut No. 1—Ellis Hansen Display, Showing Figure of Frieda Hempel



Cut No. 2—Attractive Ellis Hansen Display, Showing Dance Figure

trade papers, but also in such advertising journals as "Printers' Ink," "The Merchant Record and Show Window" and others. His work is also described at length in the "Library of Advertising," by A. P. Johnson, a standard work on advertising. The editor of this volume, Thomas A. Bird, who is a recognized authority on the subject of window displays, refers to Mr. Hansen as the "best man in America" in displaying musical instruments.

The Hansen displays (see cuts 1 and 2) are made in three sizes: large size, 11 feet 8 inches wide by 8 feet 4 inches high; medium size, 7 feet 8 inches wide by 7 feet 6 inches high, and the third to fit in smaller windows. In most of the displays life-size figures are to be used for center pieces. Such figures are sold separately to dealers with windows too small to accommodate the regular size displays. In this way all Edison dealers with display windows, no matter how small, are able to take advantage of the Hansen service.

The permanent frame work for the largest size display consists of three well-made wood frames, enameled in ivory tint and with openings for seven panels that can easily and quickly be replaced by other panels, thereby changing the entire appearance of the window. The cost of the fixtures, to be bought only once, is:

For large size windows, 11 feet 8 inches wide\$15.00

For medium size windows, 7 feet 8 inches wide 14.00
 For smaller windows, no fixtures required.
 The cost of panels and figures is:
 For large size windows, 11 feet 8 inches wide\$16.00
 For medium size windows, 7 feet 8 inches wide 9.50
 For small windows..... 8.85
 Record display stands, 85 cents each, or \$10 per dozen.

In its bulletin to jobbers and dealers concerning these displays the Edison Co. emphasize that such a display as this if designed and purchased by a dealer individually would cost something over \$100.

Under the service plan as it is now operated these displays are manufactured each month and an entirely different design is sent out. Each display is so designed that it will fit into the original stock fixtures purchased by the dealers subscribing to the service.

The second series is for dealers who desire a less pretentious and more inexpensive form of display. This offers a complete window display service, changed monthly, at \$1.50 per month. (See cuts 3 and 4.)

The plan of distribution of this series is as follows:

Each month a complete window display out-



Cut No. 3—A Less Elaborate Form of Display Designed by Ellis Hansen

fit is designed and prepared, and jobbers are shipped as many sets as they have on order. Each display is packed separately, ready for reshipment to the dealer, and in shape to be set up as soon as it is received. There is in each monthly display one dominating display card, supplemented by several smaller cards, as shown in the accompanying illustration, ten pieces in all each month, lithographed in poster colors, on coated cardboard, die cut and eased ready

The first monthly display of this series consists of (a) a two-part cut-out of Giovanni Zentello as a centerpiece, 22 inches wide by 28 inches high. By means of an electric light placed between the two sections of this cut-out a striking footlight effect is produced; (b) a cut-out of Mr. Edison treated in novel, artistic effect, 22 inches wide by 14 inches high; (c) four novel cut-outs each 14 inches wide by 18 inches high, and each holding an actual Re-Creation, dis-

slides in front to carry any desired messages to the public. The sign is equipped with a revolving cylinder surrounding the electric light, and which flashes different colors on the sign at regular intervals, giving the effect of extreme and delicate tints constantly flowing across the sign. The sign complete with one advertising plate is offered the dealer at \$6.50, while additional glass plates, and bearing different copy, are obtainable at \$1.25 each. The company have also arranged to supply the dealers with life-size cut-outs of Edison artists, the first being that of Anna Case.



Cut No. 4—A Different Arrangement of Same Display Material as Shown in No. 3 for placing in the window. Each display is so designed as to permit of several different arrangements. How widely different and yet equally attractive these may be made is shown by two of the illustrations herewith, which show different arrangements of the same display.

SURPRISE FOR GEORGE W. HOPKINS

Portfolio Containing Photographs of Managers, Assistant Managers and Salesmen of Columbia Branches to Be Presented to General Sales Manager on His Return From the West

During the recent absence from New York of George W. Hopkins, general sales manager of the Columbia Co., who spent the month of July on the Pacific Coast, Frank K. Pennington, assistant general sales manager of the company, prepared a surprise for Mr. Hopkins that is now materializing.

In a letter to the Columbia branch managers Mr. Pennington outlined his "surprise," the letter reading in part as follows: "You and your organization expect to and will put July 'over the top' in a big way in face of and despite every obstacle. This is a task we have set for ourselves as a splendid surprise for Mr. Hopkins. In order to make the surprise complete, convincing and leave a permanent record of your accomplishment in the office of the general sales manager, I desire you to send me at as early a date as possible an autographed cabinet-sized photograph of yourself, your assistant manager and each one of your salesmen. We are having prepared group frames, in which the pictures of the managers will be displayed on the walls of Mr. Hopkins' office. Photographs of the assistant managers and salesmen will be displayed in a handsome album, so that Mr. Hopkins can have it in easy reach at all times.

"It is our purpose to attach to each manager's and assistant manager's photograph a statement of the percentage of increase the branch shows in July, 1918, over July, 1917, and a similar statement to the photograph of each salesman. This will give our chief a complete, graphic visualization of both the personnel of the sales force and the accomplishment of each man in July.

"Now, let's enter heartily into the spirit and purpose of this July campaign, backed with Columbia determination and filled with Columbia enthusiasm, to put July 'over the top.'"

It is gratifying to note that in response to Mr. Pennington's letter the members of the Columbia sales staff entered heartily into his plan, and July sales went well "over the top." In addition to showing a substantial increase over last July, the totals for the month were ahead of June of this year, maintaining the splendid record achieved by the Columbia organization in 1918, wherein each month this year has shown a gain over its predecessor.

Photographs of the managers, assistant managers and salesmen have been received by Mr. Pennington from Columbia branches in all parts of the country, and the framed group and album will soon be ready for formal presentation to Mr. Hopkins.



This Company in order to improve its models at minimum cost has decided to concentrate its efforts of production upon the making of two models retailing at \$70 and \$90.

Convince Yourself of Operollo Supremacy and Service by Ordering a Sample---NOW.

Write immediately for descriptive literature, terms and territory.

Distributors

LYRIC RECORDS

WALL KANE STEEL NEEDLES

Operollo Phonograph Company

54 West Lafayette Blvd.

Detroit, Mich.

Record Delivery Envelopes
Safe - Swift - Secure



The heavy paper means protection; the button and cord mean speed — you can wait on more customers.

Bring out YOUR OWN NAME. Every time an envelope leaves your store, let the advertisement on it take your name to the homes and bring new trade. The advertising more than pays for the envelope. Write for samples and prices.

Lewis C. Frank, 694 Book Bldg., Detroit

CLEVELAND TRADE IN AN OPTIMISTIC MOOD

Dealers in Northern Ohio Hold Annual Outing
—Goodman Co. Affairs Arouse Interest—
Watching Effect of New Draft on Trade

CLEVELAND, O., September 5.—The annual outing and picnic of the members of the Talking Machine Dealers' Association of Northern Ohio, held on August 28, was the biggest affair of the kind they have held since the custom was adopted. The affair was primarily a social stunt, yet members came together on a business basis and several phases of the trade and prospects for better conditions were looked into critically. The picnic side of the outing consisted of various athletic and similar exhibitions.

The association continues to adhere to its patriotic ideas regarding the internment of German records. Dealers admitted they had lost some business because of the absolute withdrawal of all talking machine records which have a German tinge.

The coming of the Columbia record reproducing General Pershing's plea for aid in winning the world war is looked forward to here with much interest. Dealers predict this record, made in France, will have the greatest sale of any record ever manufactured.

Just what disposition will be made of the large stock of the Goodman Piano Co., which went into receivership two weeks ago, with \$235,000 debts and assets consisting of \$31,000 in stock, \$100,000 in a realty lease and \$225,000 commercial paper taken in payment for musical instruments, has not been stated. The company carried a large line of talking machines, records, music rolls, pianos, player-pianos and accessories. Many of the talking machines are used instruments. Default on interest on \$50,000 bonds issued May 1, 1917, brought about the receivership, which was a friendly move to protect the bondholders.

The Brunswick-Balke-Collender Co.'s Cleveland office reports an unusual business for August in talking machines and the sale of the firm's new sound producer. Despite the dullness generally prevailing, the branch office manager, W. F. Young, regards business conditions as good, all things considered.

The Collister & Sayle Co., retailer of Victor machines, is featuring the Victor dogs in an attractive line of advertising in the firm's show windows. The dogs are uniquely displayed among machines and records.

The University Music Co. is making a run on Cheney talking machines, which are becoming

MICA

BEAUTIFUL EDGE

DIAPHRAGMS OF BEAUTY

THE INTERNATIONAL MICA COMPANY

Factory, 37th and Brandywine Streets Office and Sales Department, 1228 Filbert Street

PHILADELPHIA

quite popular in this vicinity. Purchasers praise the tone of these instruments.

"We are going to put over a big September business in talking machines despite the gloomy prospects caused by the war," said Dan J. Nolan, manager of the talking machine department of the May Co. "The sweeping effects of the new draft law will probably eat into our sales force, but we are going to try and keep going."

Talking machine dealers in general admit that the new draft will "clean out" some of them, or almost so, if calls for more soldiers are as fast as General Crowder indicates. The percentage of salesmen and office employes from piano and talking machine stores in Cleveland is already quite heavy. Service emblems with several stars are displayed by some of the dealers and no one of them is without at least one star in a flag.

Friends of James H. Rogers, widely known Cleveland composer and music critic, are consoling him over the tragic death of his son, Henry, an army lieutenant who killed himself at the grave of his sweetheart, in a cemetery of a Cincinnati suburb, last week. The young man was highly esteemed and popular among music and musical dealers in this city.

Trade acceptances are gaining a good foothold among talking machine dealers, who admit that this form of commercial paper is about the best and most desirable ever offered. D. C. Wills, chairman of the Cleveland Federal Reserve Bank, and other leading bankers, have been campaigning in favor of acceptances, and piano and talking machine dealers are urged to use acceptances when they can consistently do so. Mr. Wills points out that this class of paper is desired by his bank and others because of its acceptable nature in negotiating loans.

Talking machines played an important part in entertaining delegates to the meeting of the American Bar Association and that of the Retail Dealers' National Association, in Cleveland, recently. Machines provided patriotic and other music for delegates in the convention hall and at Luna Park, where outings were held. Some of the visiting delegates declared that music, next to the Red Cross and Y. M. C. A., is the biggest element in making soldiers in camps and overseas contented while away from home and friends.

The woman manager in the talking machine

field no longer is a possibility, but a fact. Mrs. Loretta Flading is now in charge of the Eclipse Musical Co.'s retail talking machine department, and, according to General Manager C. K. Bennett, she is doing good work for the house. For some time past Mrs. Flading has had her staff concentrate on patriotic records with the result that sales have mounted big—in fact, they have only been limited by the amount of Victor records procurable. In this connection she is using to very good advantage a book of soldiers' songs, which is presented to customers, and the words of the song are followed as the record is played, with the result that the customers seem to appreciate more keenly than ever the exact value of the record. The idea is one well worth emulation. Mrs. Flading plans in September to inaugurate a series of patriotic windows, which will do their share in stimulating interest in music as a factor of importance in wartime.

The talking machine department of the Bailey Co. has been represented in an advertising way three times a week in the daily papers, thanks to the far-sighted and progressive policy of E. A. Friedlander, the manager. The Bailey Co. have been featuring the Edison to good purpose, and have recently taken on the Widdicomb phonograph—a very artistically designed instrument which is admirably displayed by this house. It is intended to enlarge the talking machine department this fall, and alterations to the end will soon be started so that the entire work will be finished ere the fall trade really opens up.

The Wolfe Music Co. has added a big line of new talking machines to its stock.

SOJOURNING IN THE ADIRONDACKS

Otto Heineman, president the Otto Heineman Phonograph Supply Co., this city, accompanied by Mrs. Heineman, left last week for a well-deserved rest in the Adirondacks. Although Mr. Heineman has made no specific promises to his associates, he has taken along a considerable quantity of Meisselbach fishing paraphernalia, including "Tak-a-part" fishing reels and other incidental necessities. Mr. Heineman's skill as a fisherman is admitted by those who know him well, and he confidently expects to prove a worthy disciple of Sir Izaak Walton during his stay in the Adirondacks.

SERVICE THAT BUILDS CONFIDENCE



We work for and with the Victor Dealer both in supplying him with Victrolas and records and in helping him sell them to best advantage. Our interest in a machine or record ends only when it is in the home of the customer, and we try to help the dealer place it there. Our dealers' confidence in us makes this possible. We're partners to that extent.

ECLIPSE MUSICAL CO.
CLEVELAND OHIO



Otto Heineman Phonograph Supply Co.



INCORPORATED

25 WEST 45th STREET, NEW YORK
FACTORIES, ELYRIA, O.—NEWARK, N. J.
PUTNAM, CONN. SPRINGFIELD, MASS.

CHICAGO

ATLANTA

SEATTLE

CINCINNATI

TORONTO

MOTOR PERFECTION

The achievements and progress in phonograph motor manufacturing in recent years are emphasized in the latest designs of

HEINEMAN and MEISSELBACH MOTORS

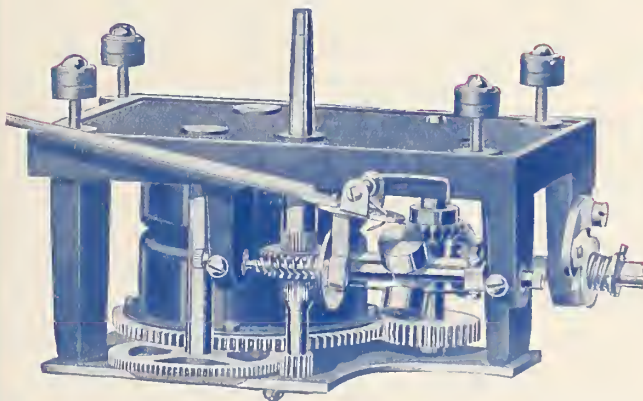

Heineman Motor No. 77

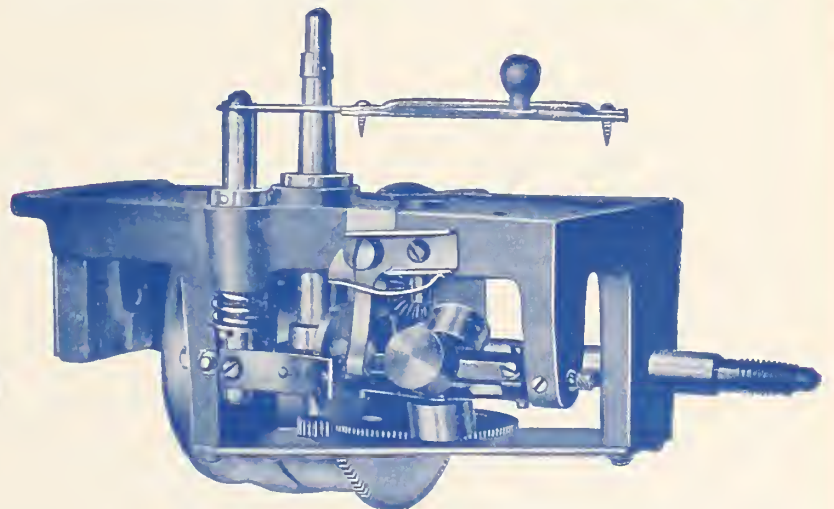

Meisselbach Motor No. 16

Q HEINEMAN and MEISSELBACH Motors are recognized the world over as the *best* horizontal and vertical spring motors that are produced.

Q They are offered to the trade with an iron-clad guarantee from the world's largest manufacturers of phonograph motors.

"We are at Your Service"

Otto Heineman
President



MEISSELBACH



TONE ARMS

MOTORS

SOUND BOXES

L. F. GEISSLER RESIGNS AS GENERAL MANAGER OF VICTOR CO.

Directors of the Company Accept His Resignation, Which Becomes Effective January 1, With Sincere Regret—Has Long Been a Figure of National Importance in Talking Machine Industry

The talking machine trade in general will learn with regret of the resignation of Louis F. Geissler as general manager of the Victor Talking Machine Co., which has been accepted with great reluctance by the directors of the company, and which becomes effective on January 1, 1919.

The resignation of Mr. Geissler was made known in an official announcement sent out to the trade by the Victor Co. under date of September 1, which read as follows:

"In the early part of the current year Mr. Louis F. Geissler, feeling that almost forty years of strenuous business service entitled him to look forward to an opportunity for rest and recuperation, advised our Board of his desire to relinquish the arduous duties of general manager at the company's convenience.

"Realizing the importance and value of Mr. Geissler's work it was with great reluctance that the Board acceded to his request and accepted his resignation to be effective at the end of the year.

"As stated in the Board's official minute acknowledging his colleagues' appreciation of Mr. Geissler's services to the company, it is a source of gratification to the directors to be able to announce that he will continue as a director after retiring as general manager and thus enable the company and its esteemed customers to enjoy the benefit of his ripe judgment and large experience.

"The office of general manager will not be immediately filled, but the functions of that office will be assumed by the executive committee. Mr. Ralph L. Freeman, a director and secretary of our company, who has been with the company in various capacities for about twelve years, will devote particular attention to and act for the executive committee in matters affecting the mutual interests of the trade and the company, assisted by Mr. Henry C. Brown as sales manager, and the selling department staff.

"The continued co-operation of the trade, so essential to a realization of our ideals of business relations and business success, is earnestly solicited."

The company's announcement was accompanied by the following statement from Mr. Geissler:

"Referring to the company's announcement of even date, which is issued now at my request, I desire to express my heartiest appreciation of your courtesy and co-operation during the thirteen years of my incumbency as general manager and to assure the trade of my continued active interest as a director in the affairs of the company, and particularly in the progress of all matters of special interest to our wholesalers and retailers.

"My prediction is that after peace conditions are restored we shall all enjoy a more rapid

development and expansion of business than ever before in the history of our industry."

Mr. Geissler, who, for the past decade or more, has been one of the most popular figures in the talking machine industry, became connected with the Victor Talking Machine Co. on October 1, 1915, after having been connected with Sherman, Clay & Co., the prominent music house of San Francisco, Victor jobbers for that territory, for twenty years as managing director. He brought with him into the company a broad viewpoint regarding the possibilities of the talking machine as an influence in the musi-



Louis F. Geissler

cal world, and it was through his efforts and through his influence as exerted upon those associated with him that the talking machine developed from what was considered a novelty and a toy to its present position in the front rank of musical instruments. Mr. Geissler has always been a firm believer in the artistic side of the instrument, and has been largely instrumental in lining up artists of world-wide renown in support of the talking machine.

Mr. Geissler's executive ability has always been of a high order, and under his management the Victor Co. developed an organization that is considered a model of its kind. Those who will assume the duties to be relinquished by Mr. Geissler are men who have long been imbued with the Victor Co. ideals, and who are thoroughly familiar and in accord with its policies.

The Reynolds News & Stationery Co., Torrington, Conn., has enlarged considerably its Columbia Grafonola department.

LENDS AID IN CONVERTING PLANTS

War Finance Corporation Extending Help to Industries Being Transformed for War Production, to Assure Firm Financial Footing

WASHINGTON, D. C., August 31.—Government financial aid was available under certain conditions to industries in the process of conversion from less essential production to manufacture of materials contributing to prosecution of the war, officials of the War Finance Corporation to-day explained. This was prompted by reports that many manufacturing concerns were threatened with bankruptcy or entire suspension during the war because they had insufficient funds to permit changes in their plants or processes necessary to transform them into essential industries.

The principal conditions for obtaining aid from the Government's half billion dollar fund established to tide war industries over critical periods are that the concern must be engaged in industry or business essential during the war period and that its credit must be of a nature to provide adequate collateral for the loan.

Bernard M. Baruch, chairman of the War Industries Board, announced to-day that curtailments of less-essential industries would become increasingly stringent as the war progressed, and that consequently the question of Government financial aid for industries under conversion promised to take on added importance. He indicated he was anxious, however, to minimize the difficulty for these industries and to prevent their wrecking or suspension for the war, and for this reason he has taken the question to the War Finance Corporation.

IT IS NOW SERGEANT MacKINNON

Emerson dealers in metropolitan territory and in New York State will be glad to know that C. D. MacKinnon, formerly traveling representative for the Emerson Phonograph Co., has recently been advanced to the rank of sergeant in the Aviation Corps of the U. S. Army. Mr. MacKinnon volunteered for service with Uncle Sam's forces, even though he had dependents, and as a member of the aviation corps was sent to Kelly Field in San Antonio, Texas. After a short while, he was promoted to the post of corporal, and now he has been appointed sergeant.

It is a coincidence that Mr. MacKinnon was succeeded in his Emerson work by another "Mac," who has the same sterling qualities as his predecessor. Bob MacMacken, who visited the local Emerson dealers before joining the U. S. Army, is now at Camp Wadsworth, S. C., and his letters are filled with enthusiasm and optimism.

Assistant General Sales Manager A. P. Burns represented the Edison laboratories at the second annual convention of Edison dealers held by the Diamond Music Co., Edison jobbers in New Orleans, in that city on August 28.

The Duo-Tone

EQUIPPED WITH TUNGSTEN NEEDLES

Soft or Loud

without changing

Thousands of talking machine owners are using the Duo-Tone and De Luxe Needles.



The De Luxe Stylus

SEMI-PERMANENT

Plays 100 to 300 Records

No Scratch or Hiss Perfect Points

Mr Dealer: Are you interested in increasing your profits and satisfying your customers? Would you invest \$11.75 to make a quick profit of \$7.45? If so, order at once our attractive Counter Display Stand or Silent Salesman, containing 12 Duo-Tones and 24 packages De Luxe Needles. *Descriptive circulars furnished.*

The Duo-Tone Company, Ansonia, Conn.

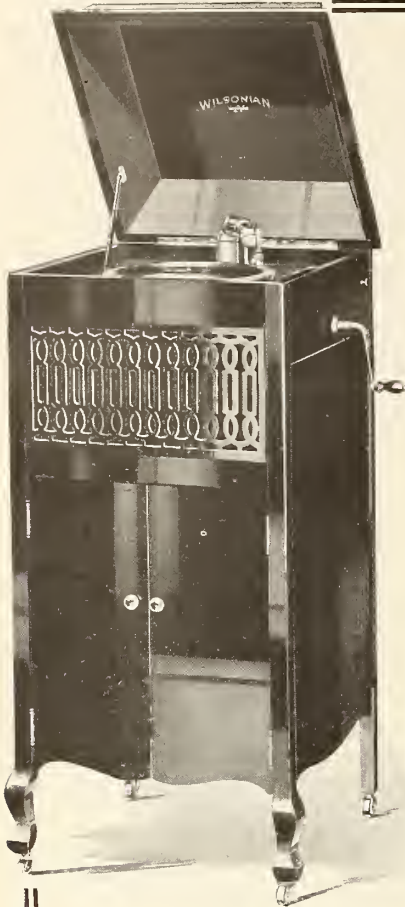

There Is A
Wilsonian
Phonograph

For Every Home

Wilsonian Phonographs are made in seven new and wonderfully improved models

Retailing at \$40.00 to \$190.00

Each instrument, regardless of its price, is of the highest quality in every detail of appearance, construction and tone refinements.

Each instrument, regardless of its price, is absolutely guaranteed by both this company and our parent concern—Wilson & Co.—the great Chicago packers.

*You Do Not Have to Turn Customers Away
 If You Handle the Wilsonian Line*

In the complete line of Wilsonian Phonographs there is a special instrument to suit every home and to fit every purse. Every prospect who enters your store can be satisfied in every particular if you have the complete assortment of Wilsonian machines ready for his inspection.

*Exclusive Wilsonian Selling Features
 Will Sell Your Customers and Keep Them Sold*

The Wilsonian has many refinements and individualities of style and construction that will appeal instantly to the most critical buyer.

The Wilsonian renders the most difficult and intricate musical and vocal selections with wonderful clearness and beauty of tone.

The Wilsonian is shown in six different models, all in conventional designs; famous for their simplicity, elegance and real piano finish.

The Wilsonian plays all makes of disc records without it being necessary to make annoying changes.

The Wilsonian is absolutely guaranteed. Both this firm and our parent organization—Wilson & Co.—vouch for the dependability of the Wilsonian.

Dealers who desire to participate in the profits that will be made on The Wilsonian this year are invited to write today for full information

Main Plant
 701 North
 Sangamon
 Street
 Chicago



Eastern
 Office
 25 West
 45th Street
 New York



A NEW SERIES OF WINDOW DISPLAYS

What the Usoskin Window Display Service Offers to the Dealer—Monthly Service Begins With the Hallowe'en Display in October

The Usoskin series of window displays which a number of talking machine jobbers have enthusiastically taken hold of is expected to make its initial appearance in the show window of the retailer at the first of October, the theme of the designs being Hallowe'en and Harvest.

The set that is furnished each month consists of twenty-three separate pieces for the window display, including card signs, price cards and record easel signs, all in colors. It is planned to have the designs and colors completely changed each month, in keeping with the seasons and happenings of the day.

This new service is owned and published by Ed. Usoskin, Inc., of New York City, a large lithographing house. They have been established for over fifteen years and have specialized entirely in the production of window and counter display cards and cutouts. The display cards of many of the large chain stores are furnished by this company.

The "men behind the guns" in the organization are Edward and Joseph Usoskin, both young men who are enthusiastic over the great undeveloped possibilities in window display. They have also just produced the new "Cardo" representations of records for all display purposes. The effect of the imitation is very good and their value in conserving the actual record is very strong in these times.

This new monthly service is a forerunner of other display services they have in mind for the dealer and jobber, and particularly solicit their co-operation as they enter the field.

They have reported that Ernest John, advertising manager of the Victor Co., said when he saw their service, "It looks pretty good to me." Many of the talking machine jobbers who have taken over the service have written their enthusiastic approval of it and have confirmed the approval of the retailers by the volume of orders that they have sent in.

NEW PATHE RECORDS WIN PRAISE

Prominent Houses Throughout the Country Write Pathé Frères Phonograph Co. Regarding the Splendid Qualities of Their Latest Records—Have Made Quite a Hit

The Pathé Frères Phonograph Co. of Brooklyn, N. Y., received recently several interesting letters from Pathé jobbers in different sections of the country, referring to the splendid tone quality of the lists of new Pathé records. These jobbers have substantiated the tenor of their letters by ordering the new records in large quantities and instilling their spirit of enthusiasm into the dealers in their territory.

An extract from the letter received from Wright & Wilhelmy, Omaha, Neb., reads as follows: "I have heard some of your new records and I certainly agree with you that they are absolutely the finest that I have ever heard and believe that if we continue to get records of such quality it will be only a matter of time when our record orders will be larger than I ever expected."

The W. W. Kimball Co., Chicago, Ill., wrote as follows: "Kindly enter our order for three hundred of No. 20428 for immediate shipment. We are advertising this number in the Chicago papers, and getting a special letter out to the trade. It is a very fine record, and you should be complimented on it."

The National Piano Co., Baltimore, Md., wrote as follows: "We have just received the October samples, and after trying them over we consider them the best ever. The way the records have been coming down has indeed been a revelation and we can not say too much for them. You can readily see by our order what we think of the October list, as this is the largest single order for one month we have ever placed."

SOME HINTS ON THE REFINISHING OF DAMAGED CABINETS

Cabinets That Are Scratched or Bruised Can Be Put in First-Class Shape Right in the Store and By the Dealer If the Proper Methods Are Pursued—Means Salable Stock

Keeping the stock in perfect and salable condition is recognized generally as one of the greatest essentials in any properly conducted store, including one devoted to the sale of talking machines. Talking machines of the better grade are highly finished and, therefore, the cases are particularly liable to be scratched by dust, or marred in other ways, and a small dent, or scratch, unless promptly remedied, will go a long way towards killing the sale of that particular machine, or at least causing the purchaser to select another and perfect instrument of the same type.

With machines as scarce as they are at the present time, the average dealer, unless he is particularly fortunate, or careless, cannot afford to have a damaged machine taking up space in his store and representing tied up capital. Of course the dealer, or salesman, sees to it that the cabinets are kept dusted and the metal parts kept clean, but dents, or scratches, inflicted during shipment, or through handling in the store, are often unattended to because no member of the sales staff has the time, or knows how to fix it, and the dealer hesitates to spend the money for an outside repair man.

As an aid to the retailer in keeping his cabinets in presentable shape and in repairing in the store at a small expense any ordinary damage that may occur, the following excellent advice on the finishing of damaged cabinets has been published in "The Voice of the Victor":

After carefully unpacking the Victrola, wipe it off with a piece of fine cheesecloth to remove all dirt and marks of packing. Then with a clean piece of cheesecloth rub the cabinet with a small portion of cleaner. Never use ready-made liquid polishes which are so extensively advertised as wonder workers. They will make the surface sticky, spotted and clouded, and destroy the finish.

By mixing three parts benzine to one part paraffin rubbing oil you will have the best possible cleaner and polisher for a Victrola cabinet. Rub briskly, always lengthwise of the grain, cleaning on all surplus polish. Brush out all the corners with a brush, preferably a soft round 3° bristle varnish brush.

If paper has become stuck to the cabinet it can easily be removed with a cloth and water. The cabinet should then be carefully dried and the surface rubbed with a 3° pumice stone, a

soft felt and paraffin oil. Care should always be taken to rub lengthwise of the grain.

Never sponge a cabinet and then expose it to the sun in the show window. The glass intensifies the heat which will blister the varnish, fade the color and ruin the whole finish. When this happens the whole finish must be removed by an expert mechanic, refinished and French polished.

Bruises or scratches should be rubbed out with a piece of soft felt, a 3-F pumice stone and paraffin rubbing oil. Go only so far as the body varnish will permit and rub only lengthwise.

If the bruise or scratch is too deep to rub out, it will have to be burned in with shellac cement, the spot leveled up with fine sandpaper and touched up to the required color. It will then be necessary to French polish it with a solution of shellac, alcohol and raw linseed oil, using a piece of cotton covered with a piece of fine linen cloth. This requires skill and experience and should never be attempted on a large flat surface by a novice.

Rubbed spots and white corners on a red mahogany cabinet can be touched up with spirit stain made from Bismarck brown, dissolved in alcohol to which a little shellac is added. For English brown finished cabinets add a little nigrosine to the above-mentioned solution. Special finishes and oak require the color adapted to the finish.

If after treating the cabinet in any or all of these ways scratches and marks still show it will be necessary to employ a skilled polisher to French polish the whole cabinet to the desired finish, which must then be dulled off with a soft brush dipped in 3-F pumice stone and cleaned up as before mentioned.

If the finish has turned gray or become spotted by being exposed to dampness or some other unusual condition, the whole finish will have to be removed by an experienced wood finisher and refinished as mentioned in detail in the above article.

INCORPORATED

Baim Bros. & Friedberg Phonograph Co., Inc., has been incorporated with a capital stock of \$60,000. The concern is a Brooklyn, N. Y., house, and the incorporators are N. Friedberg and L. and B. Baim.



Retailers:
Victor Records This Fall Will Be Scarce

We have a fairly good supply of good standard numbers.

Better mail us your order NOW.

Cabinets to match all type Victrolas. Write for quotations.

Write for information about the New Usoskin Window Display Series.

I. DAVEGA, Jr., Inc.

VICTOR FACTORY DISTRIBUTORS

125 West 125th Street

NEW YORK

How many of take nothing

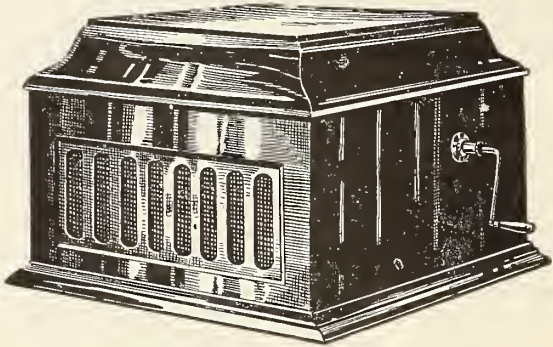

Pathé Model No. 3. Price \$40

If you are a bit tired of more "showing" than "selling" you are right where you should inquire about the

No Needles to Change

The Pathé Sapphire Ball takes the place of needles. It need never be changed.

Long Life to Records

The Pathé Sapphire Ball cannot possibly cut, grind, rip or mar the record's surface.

The Pathé Controla

With the Pathé Controla you may increase or decrease the tonal volume of the Pathé Phonograph at will.

Plays All Records

Each Pathé Phonograph plays not only Pathé Records, but all other makes of records, and plays them perfectly.

Pathé

The Quality Phonograph

Whenever there is the slightest chance of a sale, you can count on the Pathé's exclusive feature to *put that sale across*. For example, the Pathé Sapphire Ball that takes the place of needles. The beautiful, perfect Pathé Tone. And the fact that the Pathé will play all makes of records. Again and again, these Pathé features get the customer's money when nothing else would or could.

Yes, the Pathé line is *complete*—different models to meet every demand and a most liberal profit for the dealer.

Other Models to \$225



Pathé Model No. 7, \$85

Pathé Frères Phonograph Company

20 Grand Avenue

Brooklyn, New York

The Pathé Frères Phonograph Co. of Canada, Ltd., Toronto

your customers but your time?

Read—Then Write!

Read the list here of some of the new Pathé Records.



Records

See how far ahead Pathé Records are with the latest popular and patriotic hits.

And then don't stop with just reading—
Write for Pathé Dealer proposition.

Pathé Frères Phonograph Company
20 Grand Avenue Brooklyn, New York

The Pathé Frères Phonograph Co. of Canada, Ltd., Toronto

List of Records

- | | | | |
|-------|---|--|------------------|
| 20431 | { Oh, How I Hate to Get Up in the Morning
When You Come Back, and You Will Come Back | Arthur Fields
Louis Winsch | 10-in.
.75 |
| 20438 | { A Soldier's Dream
Good-bye, Mother Machree | Lots Fairman
Invincible Four | 10-in.
.75 |
| 20435 | { Everything Is Peaches Oown in Georgia
Good-bye, Alexander | The Farber Girls
Collins and Harlan | 10-in.
.75 |
| 20437 | { When I Get Back to My American Bilghty
I'm Going to Spend My Vacation | Arthur Fields
Louis Winsch | 10-in.
.75 |
| 20440 | { Ojer Kiss—Waltz
Howdy!—One-step | American Republic Band
American Republic Band | 10-in.
.75 |
| 29218 | { Sand Ounes—One-step
Watermelon Whispers—Fox-trot | American Republic Band
American Republic Band | 12-in.
\$1.00 |
| 20441 | { Beale Street Blues—Fox-trot
The Weary Blues—Fox-trot | Wadsworth's Novelty Dance Orchestra
Wadsworth's Novelty Dance Orchestra | 10-in.
.75 |
| 20430 | { The Jazz Dance
Jazzin' Around | Blake's Jazzone Orchestra
The Morso Trio | 10-in.
.75 |

MURATORE



Sings for Pathé Records Only



The *only* phonograph made with a self-stopping device that positively requires no attention whatever is the New Model Grafonola!

Columbia Graphophone Co.
NEW YORK

THE ART CRAFT CO. LINE

Six Artistic Models Which Contain Many Individual Constructive Features Being Introduced to the Trade—Win Much Praise

GRAND RAPIDS, MICH., September 3.—The Art Craft Co. of this city is placing on the market a new line of phonographs that embodies many distinctive features, and which are already meeting with a considerable measure of success. These instruments are designed to appeal to the better class of trade, and out-of-town dealers who have visited the company's offices in the Monument Building are enthusiastic regarding the sales possibilities of this phonograph.

An unusual feature in the Art Craft phonograph is the introduction of an indirect lighting system. Wires buried between layers of mahogany lead to bulbs placed under the hood. When the hood is raised, the lights reflect upon the turn table, reproducer, needle pockets, etc., and, in addition to adding to the practicability of the instrument, give it distinctiveness. The indirect lighting system is also used in the filing compartment, enabling the owner of the instrument to obtain maximum convenience when locating a record. A hinged cover balance is one of the many features of the Art Craft line, this balanced top permitting the raising of the hood to any desired height.

All parts on the Art Craft phonograph are finished in 14 karat gold, and a tone modulator permits the changing of the tone volume at will.

The company states that it is using the best motor, sound box and tone arm on the market, and thirteen records may be played with the motor without rewinding.

Six models constitute the Art Craft line at the present time and the company is making arrangements whereby representative dealers throughout the country will handle the line. The cabinets are being manufactured by one of the largest cabinet concerns in the country, and a house which is well known in the high-grade furniture trade.

THE NEW EDISON IN THE NAVY

Commanders of Four of Uncle Sam's Ships Write Letters Appreciative of What the New Edison Is Doing to Cheer Their Crews

Satisfying proof of the way the New Edison is doing its bit, through the medium of Army and Navy models placed on American warships, is indicated by the receipt of several letters recently from the officers of different ships expressing their appreciation to the company for the machines and records accompanying them. Among the ships upon which New Edisons are found, the commanding officers of which have written letters of thanks are U. S. S. "Mallory," U. S. S. "Manchuria," U. S. S. "Rijndam" and the U. S. S. "Calamares." Each of the vessels in question has two machines on board.

If you can't see the silver lining to your cloud take off your gloom-smoked glasses.

OUTING OF MEISSELBACH FORCES

Employees of This Division of the Otto Heineman Phonograph Supply Co. Have Most Enjoyable Time at Staten Island Outing

The employees of the Meisselbach division of the Otto Heineman Phonograph Supply Co., whose factory is located in Newark, N. J., held their seventh annual outing a fortnight ago, and this outing was a signal success from start to finish. Ten large motor trucks were utilized to convey the five hundred employees and friends to Fritz Grove, Staten Island; the trucks leaving the factory at 8 o'clock in the morning and reaching the picnic grounds at 11 a. m.

At 12:30 an excellent lunch was served and a



Some of the Picnickers—Supt. Vasselli in Center

program of athletic games was announced. Special prizes for these events were donated by A. F. Meisselbach, W. C. Strong, A. Vasselli and W. B. Waltzinger. The races and games were keenly contested, some of the most interesting being the fat men's race, shoe race, mile run, ladies' 100-yard dash, foot potato race and the three-legged race. Those members of the party who were not participating in the games found keen enjoyment in dancing and swimming. The music for the occasion was furnished by the Meisselbach band, conducted by A. Vasselli.

The pleasing success of the outing may be attributed in a considerable measure to the untiring efforts of Mr. Vasselli, superintendent of the Meisselbach factory, who worked out all of the details which made the day so enjoyable. Mr. Vasselli was ably assisted by the arrangements committee, who consisted of Messrs. Sharkey, Ferrari, Cataldo, Greene and Staub.

SONA-TONE CO. ACTIVITY

The Sona-Tone Phonograph Co., Inc., 3421 Broadway, New York, reports the closing of a very satisfactory business the past few months. The company has consummated arrangements whereby the Sona-Tone line will be handled by progressive dealers in different parts of the country, and according to present plans an extensive publicity campaign will be inaugurated in the near future in behalf of the Sona-Tone phonograph. The company has found it advisable to make preparations for an active fall trade, and it has every reason to believe that the factory will be oversold during the holiday season.

MELOPHONE MOTOR

No. 1

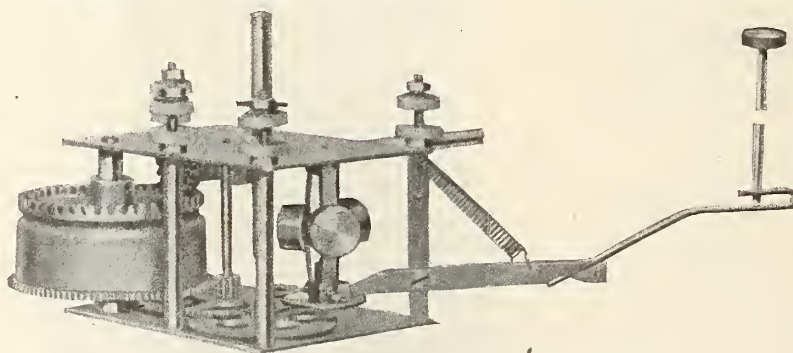

No. 1

COMPLETE WITH 10-INCH TURN TABLE

Simple in construction, the most satisfactory and durable of all small motors.

Will play two ten-inch records with one winding.

Three years' successful record as the best single spring motor manufactured.

Immediate Deliveries Sample \$2.00

Write for Quantity Prices

Melophone Talking Machine Co.

380 Lafayette Street, New York

NORTHWESTERN TRADE HAS DOUBLED WITHIN THE YEAR

Further Expansion Prevented by Shortage of Stock—Record Broken by Some Concerns—Promise of Higher Prices Stirs Both Dealers and the Public to Buying Activity

MINNEAPOLIS and ST. PAUL, MINN., September 4.—Talking machine business in the Northwest has about doubled within the year and probably could be trebled if the machines could be obtained in the quantities demanded by dealers. The outlook is the most promising that any fall has revealed and every month undoubtedly will break an old and make a new record.

With the exception of a few spots in North Dakota, the entire Northwest has been blessed with unprecedented crops, both as to quality and quantity. No crop has fallen down in any manner, and it is quite impossible to expatiate too lavishly on the agricultural wealth bestowed on the territory tributary to St. Paul and Minneapolis.

August broke all previous monthly records for the Edison Co. in the Northwest, according to Laurence H. Lucker, president of the Minnesota Phonograph Co., general distributors for the Edison goods. President Lucker went to Orange, N. J., a fortnight ago and got everything that he could clap eyes or hands on—bought absolutely everything. He had to do it, as the orders from the rural dealers had been pouring in like a flood. The shipments for the month were in excess of twenty carloads, and yet the demand is unabated. Apparently the dealers are mortally afraid that they will be caught very short just before the holidays and they are ordering much more heavily than usual. Undoubtedly the advertised advance in phonograph prices has caused the outside dealers to bestir themselves and lay in stocks while the prices were still low.

George Compton, of the famous house of Stone, Fargo, has joined the traveling staff of the Minnesota Phonograph Co., dividing the Minnesota territory with H. E. Stinchfield. Both men report the liveliest interest in the goods they purvey.

The Beckwith-O'Neill Co. find it difficult to accumulate a stock for the big fall rush for Victrolas and Victor goods, but are hopeful that stock conditions will mend before long.

Sewell D. Andrews, head of the Sonora department of the Minneapolis Drug Co., finds the outlook for his line highly promising throughout the Northwest. Several excellent accounts have been opened in South Dakota. The Williams Piano Co., Sioux Falls, S. D., has installed a complete Sonora line and will make it one of the features of its big business. Mr. Andrews states that the new Sonora at \$120, known as Fantastic, is making a decided impression with the dealers for its salable qualities.

Manager Sprague, of the Northwestern headquarters of the Columbia Graphophone Co., complains of the shortage of supplies. To-day he has orders aggregating \$60,000 which remain unfilled. Every effort is made to meet the immense call for instruments and records, but the work is still far behind. It would be possible to treble last year's trade if the shipments from the factory could be assured of sufficient quantity to warrant an aggressive sales campaign.

G. Sommers Co., distributors of the Pathé machines and records, appear to be in a commanding position for a big fall campaign. Manager Jay H. Wheeler spent a considerable period at the home office and factory and over-

looked no point whatever that would help fill his wareroom and record cases. The latter are well filled and Mr. Wheeler states that he is looking forward for the biggest Pathé season of all in the Northwest.

The Brunswick drive inaugurated by E. L. Kern, director of Brunswick-Balke-Collender Co., is meeting with success. Boutell Brothers have conducted an extensive and consistent publicity campaign in behalf of their Brunswick department. The exclusive Brunswick shop, 712 Marquette avenue, one of the daintiest and most artistic phonograph shops in the Northwest, is handling its share of the local business with much success.

SHEPARD CO.'S BIG COLUMBIA TRADE

Providence Concern Making Progress Under Management of J. D. Elliot

PROVIDENCE, R. I., August 30.—The Shepard Co., of this city, which conducts a very successful talking machine department, has closed a remarkably fine Columbia business the past few months. The company has sponsored a consistent sales and publicity campaign in behalf of the Columbia line and this campaign has produced splendid sales totals.

J. D. Elliot, manager of the Shepard Co.'s talking machine department, is a firm believer



Partial View of Shepard Warerooms

in the value of rendering efficient service to his patrons, and every member of the sales force is imbued with a spirit of co-operation that is reflected in the many expressions of approval received from the department's clientele regarding this service. Mr. Elliot is making plans for an active fall trade with the new models of Columbia Grafonolas.

HANDLING THE PHONO-GRAND

The J. P. Seeburg Piano Co. of Chicago have placed the Eastern representation of their Phono-Grand with W. B. Williams, who has taken increased quarters on the twenty-fifth floor of the new Bush Terminal Sales Building, New York City. This instrument is growing in favor throughout the country.

Misstatements in advertising often turn to be the worst kind of boomerangs.

Two popular young talking machine men left Minneapolis the last week in August for the Ensign school near Chicago. They are Paul Lundgren, manager of the Dayton Co.'s Victrola department, and John J. Roden, with the Powers Mercantile Co. These young men have been fast friends for years and even the war will not separate them. That they will earn their commissions in Uncle Sam's service goes without saying.

Mr. and Mrs. Archie Matheis are back from their annual summer automobile tour. They drove to Yellowstone Park in their new Franklin, toured the park, and then sped for Minneapolis and their numerous patrons.

Arthur Magoon, a former Minneapolis boy, for some years manager of the phonograph department of the Kieselhorst Piano Co., St. Louis, is now manager at Dayton's Co.'s phonograph department.

BUSY TIMES WITH DELPHEON CO.

Bay City, Mich., Manufacturers Working to Capacity to Keep Pace With Orders

BAY CITY, MICH., September 9.—The Delpheon Co. in this city reports the closing of a splendid summer business, and the factory is working to capacity at the present time endeavoring to keep pace with the orders received from Delpheon dealers throughout the country. The sales during the summer months were very gratifying, and the demand for Delpheon products for the first two weeks of fall indicates that these instruments are meeting with a ready sale in all sections.

Walter Verhalen, Delpheon distributor at Dallas, Tex., spent a few days at the factory recently, and before leaving for the West handed Sales Manager Gresser a good-sized order for immediate delivery. Mr. Verhalen spoke optimistically of the business situation in the Southwest and his order substantiated his optimism.

TEST offered to dealers to prove the superiority of Wall-Kane Steel Needles

Take two standard disc records of the same selection, play one ten times with the same WALL-KANE loud needle; play the other record, the same selection, ten times, but with ten new, full tone steel needles.

You will find that the record played ten times with the same WALL-KANE needle will sound clearer, will have less surface noise, and that under the magnifying glass the grooves of the record played ten times with the ten steel needles will seem to be more disturbed.



This handsome metal enameled display stand holds 60 packages, 2 doz. extra loud, 1 doz. medium and 2 doz. loud, each package containing 50 WALL-KANE needles, retailing for 15c. costs the Dealer \$5.80.

BEWARE OF IMITATIONS

Package of 50 WALL-KANE needles. Loud, Extra Loud and Medium, greater value than 500 ordinary steel needles, retails for 15c, cost the dealer 9½c.

JOBGING TERRITORIES OPEN

Progressive Phonographic Supply Co.
145 West 45th Street, New York



This Trade-Mark on a Record Album Stands for Quality

A complete line of albums—from the lowest-priced good album to the finest metal back album made.

Write for sample of our 3 grades

New York Album & Card Co., 23-25 Lispenard St., New York

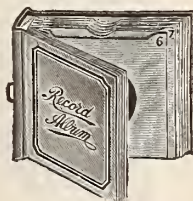

HEINEMAN FORCE AT POLICE GAMES

Entire Staff of Otto Heineman Enjoy Most Delightful Outing at Sheepshead Bay on August 24—Heineman Officials Also Attend

As a mark of his appreciation of the untiring efforts of his staff during the summer months, Otto Heineman, president of the Otto Heineman Phonograph Supply Co., extended an invitation to the members of his office force to be his guests at the police field games held at Sheepshead Bay on August 24. A week prior to the games Mr. Heineman, realizing the splendid purpose for which these games were being held, purchased several hundred tickets and used about seventy-five of these tickets for Saturday's outing.

The offices of the company were closed at 11:30 and all of the employes assembled at the executive headquarters, 25 West Forty-fifth

WALTER S. GRAY
San Francisco
Chronicle Bldg.

Pacific Coast Jobber
for the Best in Talking
Machine Trade Accessories

NEEDLES

enjoyed immensely, especially the thrilling match race between Ralph De Palma and Dario Resta. In this race De Palma broke the world's record, covering ten miles in five minutes and seven and two-fifths seconds.

After the games were over the return to the

gathering, including Otto Heineman, president and general manager of the company, accompanied by Mrs. Heineman; Adolf Heineman, assistant general manager; W. H. Pilgrim, assistant general manager; John Cromelin, general sales manager; M. E. Schechter, Eastern sales manager, and Joseph F. Higgins, purchasing agent.

INTRODUCES THE LIBERTY STYLUS

Nelson C. Ovatt, formerly president and general manager of the Duo-Tone Co. of Ansonia, Conn., resigned his position with this company recently, in order to devote his entire time to the manufacture and sale of a new stylus, which he invented. Inasmuch as the manufacturing profits are to be invested in Liberty Bonds, the new stylus has been given the name "Liberty." It is being marketed by the Liberty Stylus Co. of Detroit, Mich.

The Liberty Stylus has won considerable praise from members of the trade, who state that it has a very sweet tone, is exceptionally free of surface scratch and has several distinctive features. One of the most important sales arguments in behalf of the Liberty stylus is the fact that it is replaceable and the user may remove the stylus and replace it at will, thereby enhancing its value considerably.

The Liberty stylus is semi-permanent, playing from one hundred to three hundred records, and in some instances as many as five hundred records have been played with a single stylus. It is manufactured in full, medium and soft tone, and is marketed in packages of three needles to a package.

VISITING EDISON LABORATORIES

H. B. Stone, mechanical supervisor of the Edison Canadian jobber, W. H. Thorne & Co., Ltd., of St. John, N. B., is spending ten days at the Edison laboratories in West Orange, N. J., taking a "post graduate" course in motor construction and cabinet finishing.



Heineman Force on Way to Sheepshead Bay

street, New York, where a specially chartered Fifth Avenue bus was placed at their disposal. An interesting feature of the preliminary festivities was the appearance of an official photographer, who took the photograph that is shown herewith.

En route to Sheepshead Bay the bevy of fair young ladies from the Heineman offices acted as hostesses to several aviators from Mineola, who accepted an invitation to join the Heineman party. Track boxes had been reserved, and during the course of the games refreshments were served at timely intervals. The games were

city was the occasion for unusual speed records for an automobile bus, and, in the absence of "OkeH" records, several fair members of the party proved to the satisfaction of all present that they possessed voices of exceptional promise. The aviators joined in the choruses, and also sang their famous number, "Let's Go." The day was voted a signal success, and all members of the party expressed their appreciation of Mr. Heineman's kindness and consideration in arranging for this enjoyable outing.

In addition to the members of the office force the company's executives also attended this

AMERICAN



No. 22



No. 13



No. 5



No. 8

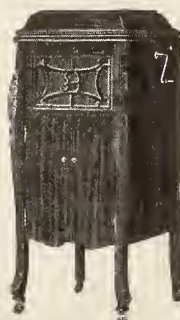

No. 9



No. 10

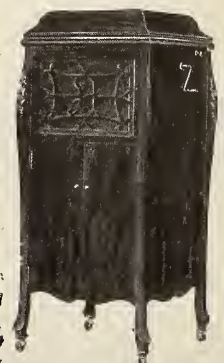

No. 11

Dealers are sometimes judged by the merchandise they sell, therefore, the name, grade and design of merchandise is an important factor. Seven models. The Americans are delivered on their merits and stay sold.

American
Phonograph Co.
39 Fountain Street, N. W.
GRAND RAPIDS MICH.

Mr. Victor Retailer

THOUSANDS OF PEOPLE PASS YOUR STORE DAILY!

WHAT ARE YOU DOING TO ATTRACT THEM?

Your windows are your best advertising opportunity to drive home to all who pass what they should know about your merchandise..

Window Displays *without* attractive show cards, that inform the public what you have to sell, are like having dummies for salesmen.

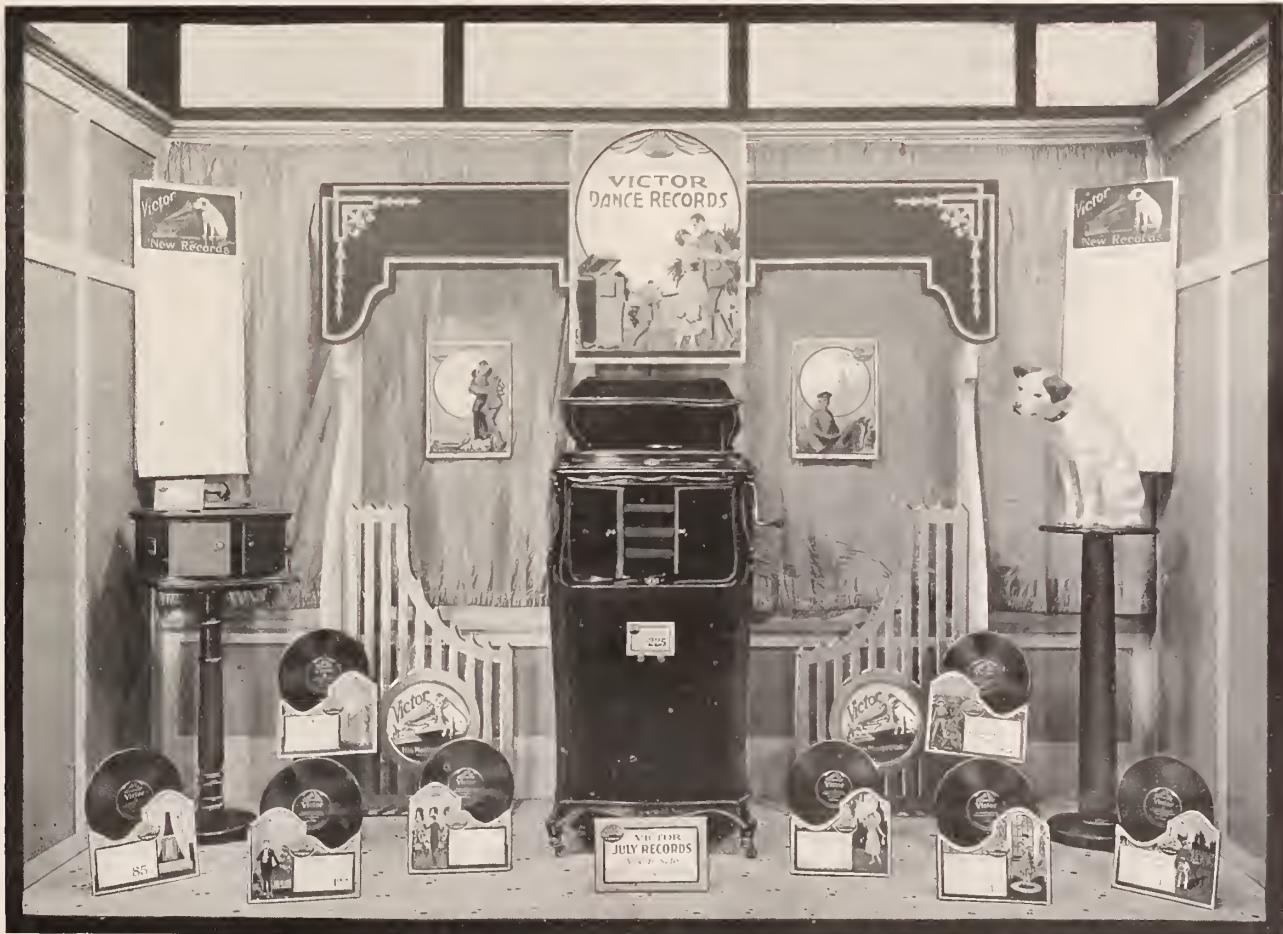

If you want a "Victor" Sign Service that is superior to others in originality, construction, quality and quantity—and retails at a wholesale price—

THE ANSWER IS ON THE FOLLOWING PAGES

ED. USOSKIN, INC., Makers of Signs and Show Cards for over 12 Years.

An Unusual

Victrola
State #225
XVI

VICTOR
JULY RECORDS
Now On Sale
We will gladly play them for you

Victrolas
Electric Models

A la luz de la luna
(In the Moonlight)
A Marvellous Melody by
Carnoso & Gogorza
No. 62033 12 inch **1.00**

Orpheus - Ballet
(Dances of the Seasons)
Phonograph by the
Philadelphia Orchestra
No. 74567 12 inch **1.50**

**There's a Little Blue Star
in the Window**
This Beautiful Melody is by Henry Russell
No. 12946 12 inch **85¢**

Two Melody Dance Numbers
Played by Victor on the Accordion
WAR BALLAD MEDLEY
ECLIPSE MEDLEY
No. 19446 12 inch **85¢**

**JUST LIKE WASHINGTON
CROSSED THE DELAWARE!**
GEN PERSHING WILL CROSS THE RHINE
The Original and Only Music by
GEN. W. M. WEAVER
The Brilliant Lyrics by
HOWARD JOHNSON
No. 12946 12 inch **85¢**

You will enjoy Dancing to the New
VICTOR
DANCE RECORDS

War Ballad Medley Fox Trot.
Eclipse Medley One Step
The Rainbow Girl Medley Fox Trot
Oh Lady! Lady! Medley Fox Trot

Come In and Hear Them

A New Record by
Arthur Guy Lempe
**YOUR LIPS ARE
NO MAN'S LAND
BUT MINE**
Music by
Charles McPherson - Lyrics by
Lester Koenig
On the Reverse Side
**OUR COUNTRY
IS IN IT NOW!**
by the Same Author
No. 6410 12 inch **85¢**

Little Mother of Mine
A Beautiful Ballad Sung by
John M. Cornack
No. 67143 12 inch **1.00**

**From North South
East and West**
The Marching Tunes of
No. 10120 12 inch **1.25**

The Rainbow Girl
The Tune of the Anniversary Show
My Rainbow Girl - Master Drummer
Victor Military Band
No. 12946 12 inch **1.00**

**Bring Back My Soldier
Boy to Me!**
A Wonderful Song Sung by
OLIVE KLINE
No. 4515 12 inch **1.00**

Offering!



SIX REASONS WHY YOU SHOULD SUBSCRIBE FOR THIS SERVICE!

The Service begins with October. You're just in time to get in on the first issue!

Your Wholesaler can supply you

and Your order in today!

- 1 INCREASE IN SALES
- 2 ATTRACTIVE WINDOWS
- 3 A REAL "VICTOR" SERVICE
- 4 MOST PRACTICAL OUTFIT MADE
- 5 BETTER CARDS FOR LESS MONEY.
- 6 ENTIRE NEW SET OF SIGNS EACH MONTH

THIS IS WHAT YOU GET EACH MONTH

- 3 {
- 1 - 22 x 28 Card Sign
 - 2 - 11 x 14 " "
 - 1 - 7 x 11 " "
 - 11 - 3 x 5 Price Cards
 - 8 - Record Easel Signs

**EVERY MONTH NEW DESIGNS!
EVERY MONTH NEW COLORS!**

FILL IN AND SEND TO YOUR WHOLESALER

.....191

Wholesaler

KINDLY ENTER OUR ORDER WITH ED. USOSKIN INC. 230 WEST 17 TH ST. NEW YORK, FOR ONE YEAR'S SUBSCRIPTION TO THEIR SPECIAL MONTHLY VICTOR SIGN SERVICE FOR WHICH WE AGREE TO PAY \$2.50 PER MONTH PLUS POSTAGE, FOR TWELVE MONTHS.

Name

Address

Town.....State.....

Don't Waste Good Records for Display Purposes!

THEY SCRATCH, WARP AND SPOIL



“CARDO” IMITATION RECORDS

FOR ALL ADVERTISING AND DISPLAY USES

ORDER THEM THROUGH YOUR WHOLESALER

Packed 24 in a Box

10 Black Labels	} \$ 3³⁵
6 Red “	
4 Blue “	
4 Purple “	

Manufactured by **ED. USOSKIN, INCORPORATED**
Mounters and Finishers
230 West 17th Street, New York

GET A SET FOR USE IN CONNECTION WITH OUR WINDOW DISPLAY SERVICE.

What Victor Wholesalers Say About Our Service.

Over twelve years of specializing in Window Cards and Displays for the Retail Trade, will enable us to give you a Victor Sign Service of exceptional merit.

DON'T FORGET, the first issue starts in October. Send your Wholesaler your order at once.

The Service you will eventually want.

ED. USOSKIN, INC.
Printers & Lithographers

230 WEST 17th STREET, NEW YORK

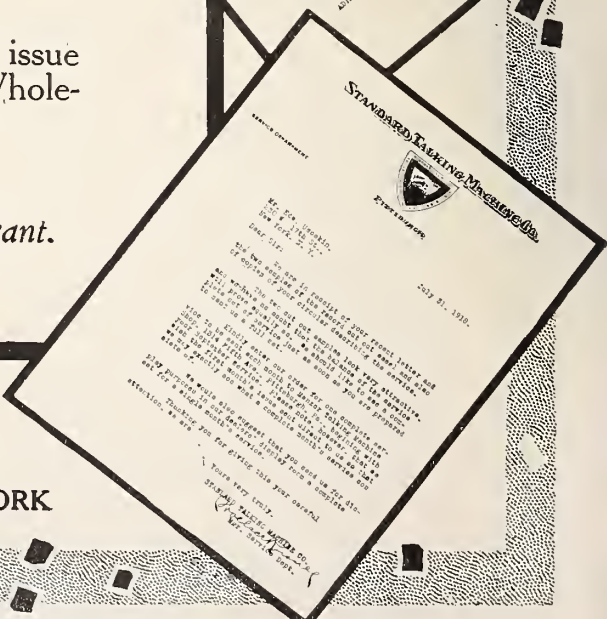
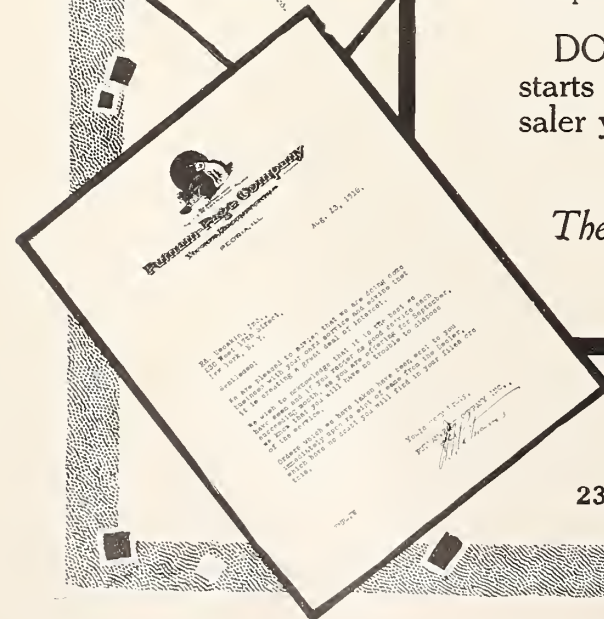
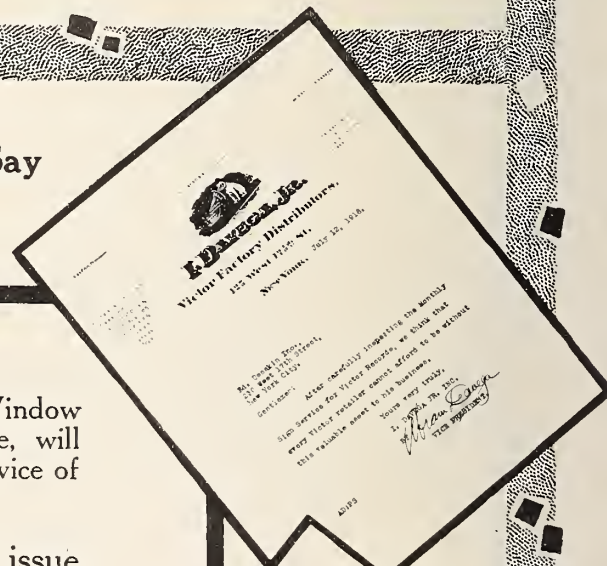
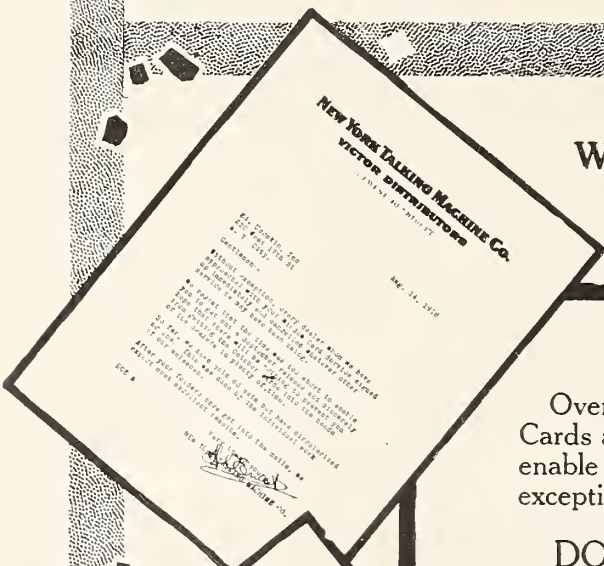

Featuring the Musical Possibilities of the Talking Machine

By William Braid White

[Note.—This is the nineteenth in a series of articles on the general subject of the musical possibilities of the talking machine. The aim of the series is to develop these possibilities from all angles, thus opening up fields for sales expansion oftentimes neglected wholly or in part.—Editor.]

THE QUESTION OF GERMAN MUSIC

When thousands and thousands of automobiles enjoyed an unwonted respite from their toil on the last Sunday in August at a simple request from the Fuel Administrator of the United States, more than one practical thinker heaved the proverbial sigh of relief and exclaimed, "Thank heaven, the country is at war at last." The implied gibe was not without an appositeness of its own. In very truth, so much is being uncovered day by day that one finds it easier and easier to bring forward for discussion, and even to secure the adoption of, ideas which even a few months ago would have been considered altogether beyond debate. We are at war; and thank the Lord we really know it now!

Music of Enemy Origin

All of which is a preliminary, more or less apt, to certain remarks we are desirous of making about the question of German music, in reference to the talking machine especially. Up till now there has been very little talk, apt or inept, about the matter, probably because it has not as yet been presented to the minds of the trade definitely enough. But the time is surely coming when the patriotic public, as represented in the national, State and local Councils of Defense, and in similar organizations, will begin to cry for some sort of a ban on the music of the Hun. What follows is written for the special purpose of preparing the talking machine dealer for an agitation regarding music of enemy origin, which is sure to come.

In the first place, it is evident that the events of the past year have had an influence enormously powerful upon the sentiments and feelings of the people towards all matters of patriotic import, whether of intimate or remote interest. The American people are at war, and are thoroughly conscious of the fact. The enemy mesmerism seems to be dissipated, and it is more and more evident that nothing is to be allowed to interfere with the ruthless and successful prosecution of the war to the utmost of American power. Now, it is becoming well known—and indeed the progress of the discovery measures the progress of American determination in the war—that the enemy of mankind has not scrupled in the least to utilize for his purposes every possible weapon of education and suggestion. He has worked very largely in past years through the medium of the arts; and in none of these so successfully or thoroughly as in the art of music. For many years the people of the United States have been patiently educated into the belief that German music is not only the best, but the only genuine music; that German musicians are the only thorough musicians, German editions the only good editions, German teachers the only good teachers. Idiotic as it may seem in the light of what we now know, the fact remains that the names German and Music had become almost synonymous in the American mind. We had become quite completely hypnotized and most of us were even boastful of our mental slavery.

Reaction

Now, any one who knows the workings of mass-suggestion knows that, when a wrong thought is exposed and the current of mental action is reversed, the reaction is always equal to the previous action. The pendulum swings in one direction just as far as it swung in the opposite direction previously. The reaction against German thought will certainly take the form of a reaction against German music; and

that will include and affect all music of German origin reproduced for the talking machine.

Modern Frightfulness

Now, it would be a calamity if the music of Mozart and of his immediate predecessors and successors were altogether cut out; but it would not in the least be a calamity if every single bit of modern German composition, everything written since Mendelssohn and Schumann, in fact, were dropped entirely. Modern German music is mostly bad and often pathologic. The ravings of Strauss, Schoenberg and Reger are often unspeakably unintelligible, and it is safe to say that they have done the world simply no good at all. On the other hand, by removing from our shelves all stocks of such stuff, we should simply be making way for an immense quantity of really first-rate "Allied music" as it might be called; music which we have never known and which we ought to begin to know from now on.

The New Demand

Talking machine dealers might, I think, begin to take action at this juncture, action that will ensure them the profit of the changes impending in public demand, while at the same time freeing their own mentalities of the cloud of mesmeric worship of the Hun and his music, which has for so long concealed the truth. In the first place, it is decidedly desirable that we should have some clear understanding of the position of the German in music and of the relation of other national schools to the German. We shall find our appreciation of our Allies, and of ourselves, too, growing greatly as a result, and we shall be able in consequence to adopt a policy for the future sale of records of artistic music, which will in every way coincide with the condition of public opinion and likewise prepare for the permanent development of a free and untrammelled American musical culture after the war.

To put it most briefly, it is worth our while, both as men and women deeply interested in the music business and as American citizens deeply interested in the total extinction of the Hun's power to harm, to learn something of the truth about the music of our Allies, and to gain enough knowledge to give us at least a

desire to acquire more knowledge of the same sort. The more we know of the music of France, Britain, Italy, Belgium and Russia, the better it will be for us.

"Scrap 'Em!"

There is another point worth our consideration before we turn to the actual facts of Allied music history. Records in the German language are really, as it happens, not so very many, and most of them are either German folk-songs or selections from the Wagnerian dramas. It is unfortunate that the good should suffer with the bad, the innocent with the guilty, but one may say without much regret that if every talking machine dealer were at once to discontinue the sale of German-language records, he would lose little or nothing by the act, while he would certainly gain much in the way of prestige.

Italy

Let us first consider very shortly the case of Italian music. Italy is our Ally and has borne with much patience and colossal energy a burden scarcely appreciated outside her borders. Her aid has been invaluable. There was a happy time during our earlier and more innocent days when we in this land loved Italian music and especially Italian opera. It speaks volumes for the good common-sense that underlies all our American thought after all the mesmerism of German suggestion, that we have never entirely lost our love for Italian music. And why should we not love it? Italy has always been the home par excellence of music. Italian is the accepted musical language, in which all musical expression is indicated. Italian technical terms are understood by musicians and music-lovers the world over and need no translation. The greatest German composers, Bach, Haydn, Mozart and Beethoven (dead and gone a hundred or more years since), all used Italian terms, signed their names in the Italian style and wrote the music for Italian libretti. As it fortunately happens, Americans have always liked Italian singers, mainly because they are the best singers in the world. Hence, Italian records by Italian singers of Italian music are the most popular records in

(Continued on page 56)

7th Floor

229 Fulton Street

Clifford A. Wolf

MANUFACTURER OF

Diamond and Sapphire

Phonograph Points

New York City

Phone, 1678 Cortlandt



The New Non-Set Record Stop is a Self-Starter for Sales. Found only on the New Model Grafonolas!

Columbia Graphophone Co.
NEW YORK

THE MUSICAL POSSIBILITIES OF THE TALKING MACHINE

(Continued from page 55)

the catalogs. So you are safe and more than safe in boosting them now more than ever and in saying over and over again that Italy is the home of music, Italian song the mother of song, and Italians the inventors of the fiddle, the piano, the organ and the musical scale. What more can you ask than that? So much for the first of our Allies.

Belgium

Now, poor Belgium, outraged, ravaged, forced to endure four years of slow death attended by unnamable horrors, Belgium is also entitled to be known as a mother-land of music. For it was in Belgium that during the middle ages church music reached its greatest heights of beauty. Counterpoint, the basis and cornerstone of all music, was taught to the German Bach by the Belgian pioneers, such as Ockeghem and his school. The great school of organ playing from which all our modern work takes its root, and whose latest genius was Bustehude, from whom Bach himself and Handel learned their first lessons of true art, was Belgian in conception and development. To-day the greatest living violinist, Ysaye, is a

Belgian. The greatest of recent composers, Cesar Franck, king and father of the modern Gallic school, died in 1894. The finest collection of wind instruments in the world is in Brussels and the curator of the museum of the Brussels Conservatory, where these instruments are found, is the greatest authority on wind instruments in the world. Belgium has turned out great musicians, great executants, great composers; she has above all maintained the beauty and glory of her wonderful carillons, those lovely bells which, from the cathedral of Malines, from Ghent, from Antwerp, from poor Liege, from murdered Ypres, have for centuries played for the people their daily and nightly hymns, floating in heavenly tones through the peaceful air. The fine art of carillon playing is peculiarly Belgian and nowhere else has its ethereal beauty been maintained with such fidelity. Boost Belgian music all you can. It is good, yes, great; and supremely beautiful.

La Belle France

What need to enlarge on lovely France, France who taught Mary Garden to sing, France of Pol Plancon, of Marcel Journet, France where the Pole, Jean deReszke, found his most gracious welcome, France which sheltered that other Pole, Chopin, the poet of the piano, France of Charpentier's lovely Louise, of Gounod's Faust, of Bizet's Carmen, France of Lully, who made opera great, of Rameau, who made modern harmony clear, France whose players of oboe, clarinet and horn are the world's masters; what shall we say of her? Who can hear that lovely voice of Garden telling the love and woe of lovely Louise, or the mystic beauty of Melisande, without wanting to love France, her language and her genius. Boost France, dear sir, and French music. It is good and great.

This has all been very sketchy and has omitted mention of Britain, or of the other nations struggling for freedom, such as Poland and Bohemia. But enough has been said to clear up the main point; and I shall return to the subject later. Remember this anyway; that Allied music is to be boosted from now on, for both patriotic and practical reasons.

B. M. ALTER NOW IN SERVICE

B. M. Alter, a former member of the staff of the Boston Book Co., and a brother of the president of the concern, was a recent visitor at the company's New York offices. He is now a member of Uncle Sam's forces and made the trip prior to his new assignment.

H. J. SMITH—Jewel Manufacturer

MANUFACTURER OF—Phonograph Diamond and Sapphire Reproducing Points—Recording Laboratory Jewels—Jewel Bearings for Electrical Instruments—Rough Diamond—Diamond Powder—Experimental Work.

Telephone 2896 Market

833 BROAD STREET NEWARK, N. J.

CHANGES IN CINCINNATI TRADE

Fritsch Talking Machine Co. Removes Retail Salesrooms—Otto Heineman Phonograph Supply Co. Discontinues Local Branch

CINCINNATI, O., September 10.—A decided shortage in talking machines of all kinds is the prospect for the trade in the Middle West for the remainder of the year. This, at least, is the prospect for the Cincinnati district.

The condition at this writing appears to be due to the lack of shipping facilities and the buying public gobbling up what was in sight. Take the Starr Piano Co.'s Cincinnati branch, which closed the month of August without a talking machine on the floor, the entire stock having been cleaned up. The prospect of getting more from the Richmond factory is not very good for the time being.

The Fritsch Talking Machine Co. has decided to close its Fourth street salesroom. This will be consolidated with the factory on West Seventh street, east of Plum, which is well located for retail trade.

The Cincinnati branch of the Otto Heineman Phonograph Supply Co. has been closed, and C. W. Neumeister, who was in charge of the Middle West district, will return to New York City. Just now he is confined to his home, suffering from the after-effects of an operation on the tonsils.

INCREASE YOUR SALES Mr. Edison Dealer, with the KENT Attachment and Sound Box



Patented March 2, 1915

SIMPLE AND ACCURATE

Made by manufacturers who have specialized in Edison attachments for years.

SEND FOR ONE TODAY

Most Edison jobbers handle our products. If yours does not send direct.

F. C. KENT & CO.

Manufacturers of Phonograph Accessories

COR. MULBERRY AND CHESTNUT STS., NEWARK, N. J.

What More Can You Ask

All the features that go to make a talking machine *Profitably Salable* you will find as regular equipment of *Magnola*: "Built by Tone Specialists."



Watching the Music Come Out

Complete description of all these features is to be found in our *handsome illustrated catalog*, which we should like to send you. May we? Ask us to tell you our plans for your benefit!

MAGNOLA TALKING MACHINE COMPANY

OTTO SCHULZ, President

General Offices
711 MILWAUKEE AVENUE
CHICAGO

Southern Wholesale Branch
1530 CANDLER BLDG.
ATLANTA, GA.

Not Merely a Phonograph or Talking Machine

But

The Final Word in Reproduction of Tone and Craftsmanship



Something New and Entirely Different

The Talking Machine Industry has always been thoroughly awake to the importance and necessity of advancement, the sanitary flush top, the balanced cover support, universal tone arm, tone modifier, automatic stop and design of cabinets all have contributed their share toward making the Talking Machine an attractive piece of furniture.

We have all these improvements and have added a lighting system which lights the entire cabinet, being indirect in the cover and the filing compartment completely lighted, YOU CAN READ THE RECORD IN THE CABINET.

A Dream Come True

Even in this day of artificiality the restless spirit of progress, with enthusiastic endeavor and love of achievement, has accomplished things heretofore dreamed of, that the reproduction of tone which would fully exemplify the artistic requirement of musical art be resonated from an exquisitely built and perfectly designed instrument.

Quality vs. Price

It being our object to build an instrument of quality, price has been a second consideration, yet we have been able to build a popular priced line due to the fact that Grand Rapids is the furniture city of the world, placing at our command the best of furniture workers and materials necessary in the proper construction of high grade furniture.

Exclusive Designs for Discriminating People

The Art Craft is the product of an inspiration to meet the demands of artistic refinement for the cultured music-loving ear, and for those who desire the harmonies which belong to "The House Beautiful"—the things that grace the surroundings in well appointed music and drawing rooms, the latest and most complete innovation presented to the music world.

Unless you are handling the Art Craft Line you are not offering your customers all that a given sum of money can buy.

▼
Attractive Proposition for Dealers and Jobbers

▼
WRITE TODAY

Are You
"PREPARED"
for the
Holiday
Business
with an
Instrument
that will
sell by
Comparison?

▼
Six
ART MODELS
\$115 to \$350

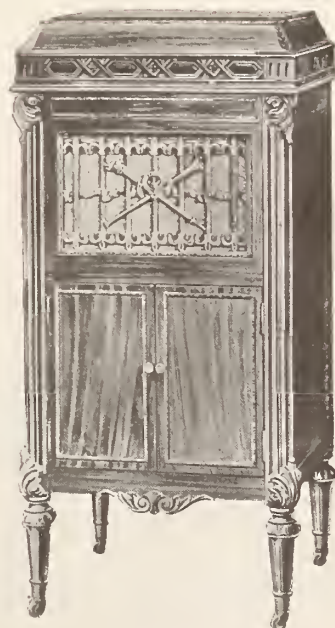

The Art Craft Company

MANUFACTURERS OF

The Art Craft Line

PHONOGRAPHS

GRAND RAPIDS, MICHIGAN

ENORMOUS TRADE LOOKED FOR AT ALL SOUTHERN POINTS

With Cotton Above Thirty Cents People of Atlanta and South Have Money to Spend and No Small Share of It Will Find Its Way for Talking Machines and Records

ATLANTA, GA., September 8.—Conditions in this city continue very satisfactory, and from the reports following it can be seen that business is progressing nicely.

The Haverly Furniture Co., Columbia and Pathé dealers, possibly the largest retailers of phonographs south of New York, having a chain of stores in Georgia, South Carolina, Alabama, Tennessee and Texas, say that their business for August was only slightly less than in July, which was the largest month with them this year. They expect a continued active business during the rest of 1918.

I. M. & R. D. Bame, Victor and Sonora dealers, report that their August sales were very fine, and that they have never seen as much cash in evidence as at the present time. They are buying all the stock that the factories will supply them with and look for a record autumn business.

Phillips & Crew Piano Co. are understood to be doing an excellent business. They are Victor jobbers, and have a retail store in connection with their warehouses, but so active is the demand for Victrolas and Victor records that they are using practically their entire wholesale stock to supply their retail demand.

This concern continues to put forth the very highest class of advertising in the daily press, and no doubt a considerable measure of their success can be traced to this.

The Atlanta Talking Machine Co., which is the original Columbia store in Atlanta, having succeeded to the original retail store of the Columbia Graphophone Co., under the efficient management of W. G. Sunderland, whom they have recently employed, is doing the largest business of any period in recent months. Immediately upon Mr. Sunderland connecting with them, their sales took a spurt, and they are more than ever an active figure in the talking machine world. They, in common with other dealers, expect a continuance of the present era of prosperity for an indefinite period.

The Cable Piano Co., Victor retailers, and the largest in this section, are enjoying a large volume of business, with no apparent decrease in sight. They are selling all they can get, and about as fast as they can get the Victrolas in and place them on the display floor they are sold, in fact, frequently they are simply remarked and expressed to some neighboring town, or at once placed on a truck and delivered locally. With the very large buying power of the Cable Company, and the unusual efforts they make to get and keep a supply of Victrolas on hand, this certainly indicates "some" business.

Mr. Purdy, manager of the Diamond Disc Shop, states that his August business was quadruple the volume in August, 1917. He reports that he received recently twenty-five of

the better grade Edisons, and sold them all in a few days. His cash business, cash on first payments and record business is far ahead of anything prior to this time. Frieda Hempel's records are selling excellently.

Chamberlin-Johnson-DuBose Co., Victor and Sonora dealers, are continuing a most satisfactory business. They have in the past ninety days sold as much as they did in the first five months of the year, and their sales volume is constantly increasing. Mr. Edward Brotherton,

manager of the talking machine department, expresses the opinion that things have just begun to "open up."

The Dictaphone, Mr. Brown, manager, report that August was the largest month they have ever known in the history of their business, the increase over last year being about 300 per cent., and they have in sight a large volume for September.

With the price of cotton far above 30 cents and still advancing, and the fact that every big shell or rifle cartridge fired in the Allied armies, uses up cotton, and every truck that moves requires cotton on the tires, there is no question but that the South is "in the saddle" in a business way as it has never been before.

TAX DISCUSSION HURTS RETAIL TRADE IN LOS ANGELES

Business Astonishing for Month Despite Vacations—New Revenue Bill Created Uneasiness for a Time—Important Meeting of Retail Talking Machine Dealers' Association—News of Month

LOS ANGELES, CAL., September 5.—Business was certainly astonishing during August and this was especially pleasing to the music houses inasmuch as it has always been considered one of the slowest months in the year, so many people being away on vacations and not returning until in September. Every house in Los Angeles, without exception, had a banner month and the only worry now is the shortage of stock. From present indications this will be a serious factor in the amount of fall business of the local merchants. A good many persons got in on the old Edison prices and secured their machines before the raise on September 1.

Many owners of talking machines at the present time have been worrying about the proposed Government revenue war tax, which has been reported as high as 25 per cent. These reports have, of course, hurt business to a certain extent, a great many persons hesitating about purchasing an instrument for fear that it will be heavily taxed after they get it home. The local Talking Machine Dealers' Association sent telegrams to the three largest factories, Victor, Edison and Columbia, asking for information on the subject and the answer from all three was practically the same—namely, that the tax would not exceed 10 per cent. in all and would be a gross tax at the factory which the consumer would ultimately have to pay, also that this tax does not apply to machines purchased prior to the passing of the Revenue bill.

The local Red Cross has been doing some excellent work during the last two or three months in supplying the soldiers and sailors with machines, records and all kinds of musical instruments. These are much appreciated by the boys in the service and bring them much enjoyment at the various camps.

Captain Frank Hanford, of the United States Medical Corps, who has just been called into service, purchased an Army and Navy Model Edison Diamond Disc from the Southern California Music Co. to be sent to whichever cantonment he is assigned to.

Earl S. Dible, for many years connected with the talking machine line in southern California, has accepted a position with Sherman, Clay & Co., of San Francisco. Mr. Dible will be either at the main store or in Oakland.

The Retail Talking Machine Dealers' Association of Southern California held their regular monthly meeting August 20 at the Starr Piano Co. on South Hill street, there being about fifteen houses represented. Samples of their new stationery were passed around to the members and the design was much admired by all present. Several important matters of business were discussed and the following schedule for trade allowances on talking machines was adopted: 1, cylinder horn machines, \$5 maximum; 2, table machines, 33½ per cent.; 3, disc horn machines, 15 per cent.; 4, cylinder Amberola covered, 25 per cent.; 5, disc, hornless, uncovered, 33½ per cent.; 5, disc, covered, obsolete style, three years, or older, 50 per cent.

One of the dealers, a member of the association, having a grievance against one of the well-known talking machine manufacturers in the East, the matter was taken up by the association and referred to a committee for adjustment. George S. Marygold, vice-president and general manager of the Southern California Music Co., made an interesting talk about the forming of a similar association in San Diego. Mr. Marygold was present when these dealers had their first meeting and said they were all very enthusiastic and immediately passed a rule to limit talking machine contracts to twelve months.

Irving Andrews, of the Andrews Music Co., has just returned from Catalina Island, where he and his family spent an enjoyable vacation.

Herman Beck, manager of the talking machine department for the George J. Birkel Music Co., reports business fine, and recently on a Saturday sold six machines, all Victrola X's.

Mr. Boothe, of Barker Brothers, is more than pleased with their summer business and says his only worry at present is where to get enough goods to run them over the holidays.

The "VANOPHONE"—RETAILS AT \$15



VANOPHONE MODEL B

Guaranteed in every detail by
a company of country-wide
prominence

☞ In design, tone quality and construction, the Model "B" Vanophone compares very favorably with the standard high priced machines.

☞ The Vanophone is noteworthy for the excellence of its reproducer—the "Artois," the durability of its motor and the artistic design of its cabinet.

Write today for trade prices. Immediate deliveries assured

The Garford Mfg. Co., Elyria, Ohio

WAR REVENUE BILL GOES TO HOUSE OF REPRESENTATIVES

Talking Machines and Records Subjected to 10 Per Cent. Excise Tax on Manufacturers' Price—Removed From Luxury Class, Thanks to Efforts of Trade Committee

WASHINGTON, D. C., September 4.—Shortly after noon yesterday the Ways and Means Committee reported to the House the new eight billion War Revenue bill, the largest revenue bill ever presented to any legislative body in the world, and it was announced by the House that consideration and debate of the bill will begin on Friday. It is hoped that the bill will be passed by the House before the end of next week, when it will go to the Senate for consideration.

On Friday the Senate Finance Committee will open hearings on the measure. The hearings will be limited to one week and will not be extended for more than ten days. At the present time no announcement has been made as to whether the talking machine interests will be represented at the Senate hearings, although it has been reported that little organized effort will be made to have changed the present paragraphs, as they relate to the excise tax on talking machines.

Due to the efforts of H. L. Willson, of the Columbia Co., representing the trade at large, attempts to include talking machines and records among luxuries and liable for a special

tax on the retail selling price were frustrated, and the bill as presented to the House provides a 10 per cent. tax on the manufacturer's price. In other words, a 7 per cent. increase over the present war excise tax. Talking machine men also declared themselves pleased with the fact that there has been no discrimination in the tax on musical instruments in the new bill, and that pianos were also included with talking machines and other instruments, as being subjected to its provisions.

Section 900 of the bill relating to excise taxes and covering musical instruments reads in part as follows:

Section 900. That there shall be levied, assessed, collected, and paid, in lieu of the taxes imposed by section 600 of the Revenue Act of 1917, upon the following articles sold or leased by the manufacturer, producer, or importer, a tax equivalent to the following percentages of the price for which so sold or leased.

(4) Pianos, pipe organs, piano players, graphophones, phonographs, talking machines and records used in connection with any musical instrument, piano player, graphophone, phonograph, or talking machine, 10 per centum.

FOUND TRADE OPTIMISTIC

J. F. Collins, General Sales Manager of the Pathé Co., Tells of Successful Trip

Joseph F. Collins, general sales manager of the Pathé Frères Phonograph Co., Brooklyn, N. Y., returned recently from an extensive trip, which included a visit to the Pathé jobbers and dealers in Michigan, Ohio, New York, Pennsylvania, Georgia and Florida. In a chat with The World Mr. Collins spoke enthusiastically of the business situation in this territory, stating that during his twenty-two years' association with the talking machine industry he has never found the trade so optimistic and encouraging in their predictions for the future.

Mr. Collins states that the dealers and jobbers are viewing the situation from the correct viewpoint, and are stocking up now in order to handle fall and holiday trade properly. The public as well as the dealers as a whole realize that phonographs and records must retail for higher prices than last year, and the dealers, recognizing the tremendous increases in the cost of labor, raw material, transportation, etc., are working in close co-operation with the manufacturers and jobbers.

JEWEL LABORATORIES ENLARGED

H. J. Smith, the well-known jewel manufacturer of Newark, N. J., recently enlarged the laboratories of his company. Several new employes were also added to the experimental department. Mr. Smith will shortly make a trip to a Western recording plant where his services are desired in the reproduction department. He has had many calls from large record companies during the past few months, and recently returned from a Canadian record factory, after spending several weeks in their recording rooms.

MULTUM IN PARVO

C. A. Hanson, factory manager of the Columbia Graphophone Co., Bridgeport, Conn., is credited with the remark, "No one's responsibility ceases this side of a satisfied customer." There is a book full of truth in these few words, and they should be read and re-read by every business man who desires to succeed, for a satisfied customer means inevitably and necessarily a large and profitable business.

DAVENPORT CABINET WORKS
Davenport, Iowa
MANUFACTURERS OF PHONOGRAPH CABINETS

REPORT LARGE SALES TOTALS

C. L. Byars, of the Aeolian Co. Branch in Cincinnati, Tells of Progress

CINCINNATI, O., September 5.—C. L. Byars, of the Aeolian Co.'s branch in this city, states that August sales totals showed a substantial gain over last year, and that September is proving equally as satisfactory. Owing to abnormal conditions, however, it is very difficult to organize an efficient sales force for the fall work, and this problem is one of the most important confronting the executives at the present time. There are plenty of prospects for instruments and the company has every reason to expect a splendid fall trade, if it can secure the salesmen to take care of it. Mr. Byars spent a few weeks recently visiting St. Louis, where he has many friends and relatives.

The Jones Drug Co., Oregon City, Ore., is remodeling and improving its quarters and arranging for the installation of a large talking machine department.

W. A. WILLSON'S NEW POST

Appointed Manager of the Columbia Co.'s Educational Department

George W. Hopkins, general sales manager of the Columbia Graphophone Co., New York, announced this week the appointment of W. A. Willson as manager of the Columbia Co.'s educational department. Mr. Willson succeeds Frederic Goodwin, who resigned from this position the first of the month.

W. A. Willson has been business manager of the Columbia Co.'s educational department for the past few years, and in this capacity has won the esteem and friendship of Columbia dealers throughout the country. He is thoroughly conversant with every phase of educational work in the talking machine field, and his intimate knowledge of the vast possibilities of this branch of the business has enabled him to render efficient and valuable co-operation to the Columbia clientele. He is planning to introduce many sales ideas and helps the coming fall that can be utilized to excellent advantage by Columbia dealers, and he will be ably assisted in this work by W. H. Gould, sales manager of the department, who has been a member of the Columbia educational staff for several years.

DEPARTMENT REPORTS HEAVY GAIN

Business in Phonograph Department of Kaufman-Straus Co. During August Practically Double the Volume Handled During August, 1917—To Put on Tone Test October 9

LOUISVILLE, KY., September 5.—The phonograph department of the Kaufman-Straus Co., big department store of this city, under the management of H. V. Boswell, is reaping great business with the new Edison and Columbia machines and records. The department on August 1 moved into new and larger quarters on the second floor of the building, and despite the slight confusion of getting settled, recorded a volume of business amounting to 200 per cent. of their business in the department for the month of August, 1917. The department is equipped in an elaborate manner and a substantial stock of both machines and records is carried. Considerable business is being done with the soldiers in Camp Taylor. The Kaufman-Straus Co. is contemplating putting on an Edison tone test on October 9 and is at present arranging the details for a most elaborate affair.

OVERCOME THE STEEL SPRING SHORTAGE

BY USING

VEECO MOTORS

THE ELECTRIC WAY

The improved VEECO electric motor is designed primarily and exclusively for Talking Machines. It is smooth and noiseless in action and practically fool-proof. Standard models run on any voltage from 100-125, A. C. or D. C., without adjustment. Other models for any voltage from 6-250. Furnished mounted on 12 or 12½ inch mahogany board ready to install, or without board, all ready to mount on such board as used by the manufacturer.

With the VITRALOID turntable, supplied with the motor, it makes a complete motor unit for high class machines.

Send for a sample NOW and place your order at once for early fall delivery.

THE VEECO COMPANY

248 Boylston St.

Boston, Mass.

THE ORIGINAL PRODUCERS OF A COMPLETE ELECTRIC DRIVE FOR TALKING MACHINE MANUFACTURERS' USE



READY A new dealers' catalog, cover page of which is reproduced herewith, is now ready for distribution. The complete line of Console types and Uprights illustrated therein is ready to meet all competition. Send for catalog, make selection of sample line and be ready to take care of the business which is sure to come to you with a showing of the incomparable Widdicomb.

Phonograph Division

The Widdicomb Furniture Co.

GRAND RAPIDS, MICHIGAN

GAINS POINT FOR TALKING MACHINES IN WAR TAX BILL

H. L. Willson Appears Before Ways and Means Committee for Industry and Convinces Members That Machines and Records Are Not Luxuries—Combats Chamber of Commerce Views

As the result of a recent visit to Washington made by H. L. Willson, vice-president and general manager of the Columbia Graphophone Co., acting as chairman of the War Committee of the Talking Machine Industry, it is pleasing to note that the new War Revenue bill, when it was introduced in the House September 3, showed talking machines and records freed from the luxury tax proposed earlier in the session, and simply subjected to an increase in the present excise tax on the manufacturer's selling price.

Mr. Willson stated to The World that he had taken up with Elliott Goodwin, secretary of the Chamber of Commerce of the United States, the referendum of the War Finance Committee of the Chamber of Commerce to the effect that a gross sales tax of 20 per cent. be levied upon "victrolas and various other mechanical musical instruments" as luxuries, and filed a strong protest against the evident discrimination shown in selecting a trade-marked term as descriptive of the products of the entire industry. Incidentally, it might be said that the discrimination was evidently due to ignorance rather than to intent.

Mr. Willson next appeared before a special committee of the Ways and Means Committee of the House and spent considerable time in bringing before that committee facts regarding the talking machine industry as gathered by its war committee.

He called attention to the number of manufacturers, dealers and their employes who were dependent upon the industry, the amount of capital invested, and the important part talking

machines and phonographs were playing in the camps and in the trenches. He declared that to enforce a 20 per cent. gross sales tax would mean practically the killing of the industry.

The members of the committee appeared much impressed with Mr. Willson's arguments, and assured him that not only would talking machines and records be removed from the special luxury class in the new bill, but that there would be no discrimination shown against them as compared with other musical instruments including pianos, in the levying of tax assessments.

Although Mr. Willson spent only a brief time in Washington, his work was so carefully arranged that he succeeded in accomplishing unexpected results in the interests of the industry as a whole.

Regarding the question of steel supplies for the industry, Mr. Willson stated this week that the war committee of the talking machine industry was awaiting confirmation by the United States Chamber of Commerce, and that as soon as this recognition was secured the steel question would be taken up with the War Industries Board. Unofficial advices received by The World indicate that the favorable confirmation of the committee will be announced in a very short while.

The questionnaire sent out by the committee to the manufacturers of talking machines and parts has brought in a vast amount of information regarding the industry to be presented in Washington in support of its arguments for consideration, in the matter of steel and fuel allotments.

BIG CARUSO CONCERT IN ST. LOUIS

Tri-State Victor Dealers' Association to Hold Banner Session When Tenor Appears on October 22—Clever Work Saves \$1,100 in Obtaining Services of Orchestra—A Big Event

St. Louis, Mo., September 5.—The visit of Caruso here to give a concert on October 22 is going to be made a great event for the Victor dealers and the Victor owners. Already an unusual demand for Caruso records is reported.

The date of the concert is to be the signal for the gathering of the members of the Tri-State Victor Dealers' Association for their first annual meeting. This association was organized about a year ago and has never held a general meeting to which out-of-town members have been urged to attend. Several from a distance have attended some of the monthly meetings and more were present at the Koerber-Brenner Music Co. formal opening, when the association idea was explained to them, but that was a social occasion, not a business session. It is believed that the Caruso concert will prove a great attraction for the Victor dealers, who look upon the great singer as their best advertising card.

Rather an amusing story is being told of the Caruso concert plans. It was desired to employ the St. Louis Symphony Orchestra for the occasion, but the orchestra management asked \$2,300 for the concert and rehearsals, and so the Caruso managers employed the eighty members of the orchestra separately at \$11.50 each for the concert and one rehearsal. The orchestra management had asked \$500 for Leader Max Zach, who is spending the summer in Boston and would not be back until November 1, but the Caruso managers obtained the services of Leader Maronzoni, of the Metropolitan Orchestra in New York, for his expenses, or about \$250, which altogether effected a saving of about \$1,100 and leaves the local managers with a lot of explaining to do.

The Caruso concert here is one of two that the great singer will give. The other will be in Ann Arbor, Mich. He is giving these concerts on his own risk and gives 80 per cent. of the receipts to war funds—20 per cent. to Italy and 60 per cent. to the U. S.

Let us not be so engrossed in our little individual business establishments that we cannot give some time and thought to aiding in the big business of 1918, the feeding, clothing and freeing of the world.

WORK OR FIGHT LAW HITS ST. LOUIS

Talking Machine Salesmen Required by Draft Boards to Find Positions in War Plants—Local Fuel Board Issues Ultimatum

St. Louis, Mo., September 8.—The question of selling staffs is beginning to interest the local talking machine dealers. Several local salesmen have been called before draft boards recently to discuss the "work or fight" phase of the draft regulations. The first case reported was that the salesman was finally classed as a traveling salesman, although he does not leave the city and was permitted to stay on his job, "for the present at least."

Last week another case came up for decision and the man was ordered to seek other work at once. This man, a salesman for a piano house, has tried to enlist and cannot because of physical requirements. He was informed that the board could find limited service for him, which he concluded would be a clerkship at \$30 a month, so he sought a job in a shipyard and left for the East September 1.

Most talking machine men believe that as rapidly as their men come before the draft boards now they will be ordered into more essential work. So far the departure of members of the staffs has not been serious. Most of the men under thirty-one enlisted or took up more active pursuits without urging. But the men who will be affected by the new draft are more settled and most of them expect to make pianos or talking machines their lifework and are loathe to quit. The local draft boards have been somewhat slow in getting to this end of the work or fight business because of the many calls on them for men, but they have now realized the great big task they have before them and are organizing for more and better work. It is believed that this will include a rapid survey of the questionnaires and quick action against the non-essentials.

Already the local Fuel Board has notified piano and talking machine warerooms that they are listed as non-essentials, and that if there is any pinch on coal next winter they will be refused deliveries. Most of the warerooms are now provided with coal for the season.

Some talking machine men believe that only executives will be left in the warerooms, but that these men can sell all of the machines that they will be able to get.

W. L. Schutz, proprietor of the El Paso Co., El Paso, Tex., is of the opinion that talking machines and records are not to be considered as side lines in the piano business, but instead constitute in themselves an important leading part of the music business. This, by the way, is in line with the views of a great many other piano dealers who have been able to finance their business through the sale of talking machines and records in times when the piano trade is unusually dull.

THE "LIBERTY" STYLUS
Semi-Permanent Needle
Plays from 100 to 300 Records

The only Stylus or semi-permanent needle on the market that can be used, removed at any time and replaced in the needle holder without lessening the tone quality or damaging the record.

- The Liberty Stylus is manufactured in full, medium and soft tone, and is marketed in packages of three needles to a package; 50 packages in a box.
- The Liberty Semi-Permanent Needle is guaranteed to reduce surface noises to a minimum, and give a thoroughly satisfactory tone quality.

Every dollar of our profits goes into Liberty Bonds.

Samples to the trade free upon request

LIBERTY STYLUS COMPANY
Detroit, Michigan

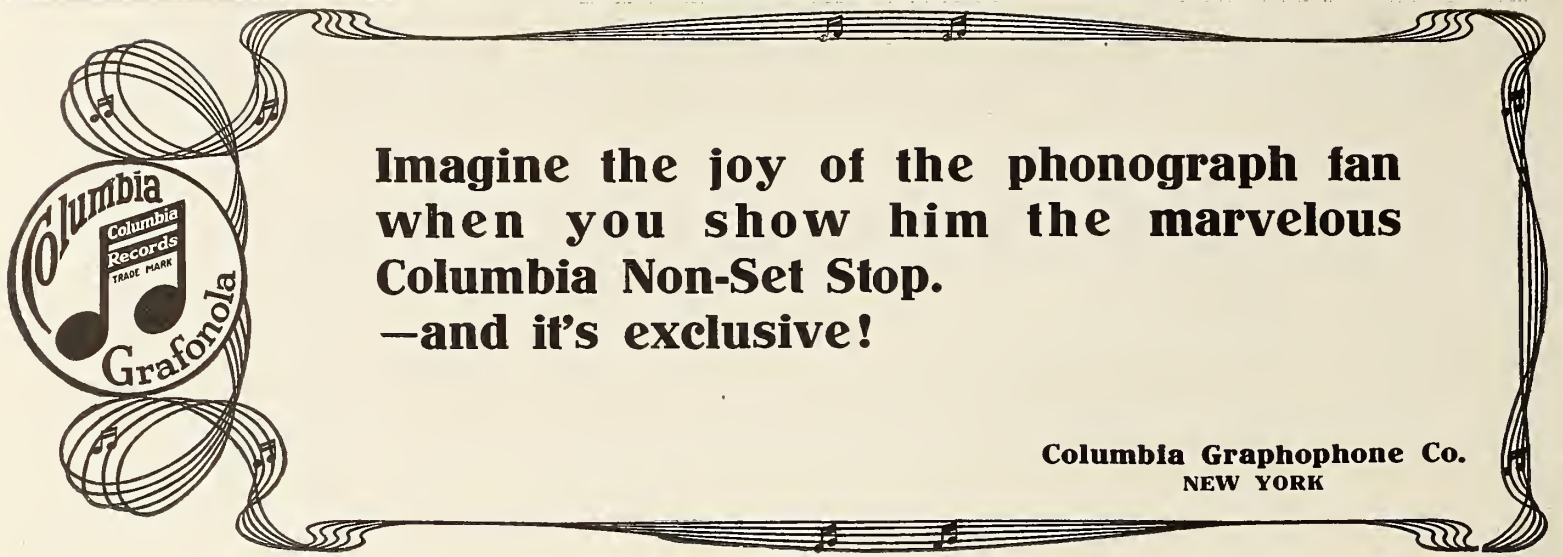

Imagine the joy of the phonograph fan
when you show him the marvelous
Columbia Non-Set Stop.
—and it's exclusive!

Columbia Graphophone Co.
NEW YORK

DETROIT REPORTS GREATEST TRADE OF ANY MONTH

Dealers Express Pleasure at Showing for August, Which Was a Profitable One—Shortage of Stock Continues to Be the Great Complaint—Association to Meet in October—Exhibitors at Fair

DETROIT, MICH., September 10.—The local talking machine dealers, based on their experience of previous years, did not look for anything but fair business during August, but it is an actual fact that of the two dozen or more retailers seen by The World representative, 100 per cent. of them stated that August was not only the best of the summer months this year, but that it was even better than any August of the past and that it went far beyond expectations. One dealer went so far as to say "it's the first month in at least four that we made a profit." Anyway, it shows that the unexpected may happen at any time and that no one can really predict what the future will bring. In telling of the big August business several dealers said "it is beyond understanding—we can't account for it—don't know why it happened to be so good." One dealer who always does a lot of advertising completely eliminated his appropriation for August, figuring that it would not do him any good, and despite his no-advertising policy in August it proved one of his best months this year.

Indications are that the coming fall and winter months will be very brisk for the talking machine dealers, only one factor counteracting this prediction and expectation—shortage of merchandise. Already this has been noticed and dealers are wondering what will happen during November and December when they will need the merchandise the most. The manufacturers and jobbers are surely doing their very best to take care of the retailers, so that if there are any disappointments no one in particular will be to blame—it will simply be a condition due entirely to the war.

The Edison Shop, on Woodward avenue, had a fine August business, according to A. B. Alling. All of the salesmen who have been

with the company since its inception are at war, so that it has been necessary for Mr. Alling to completely reorganize his staff.

Speaking for the Phonograph Co., of Detroit, who are the Edison jobbers in this section, Mr. Alling, general manager, reports that August was a very good month, and that from reports of his dealers it was a brisk month throughout the territory.

Frank Bayley, of the Bayley Music House, Edison retailer on Broadway, is anticipating the biggest fall business in his history. His talking machine business has grown to such proportions that the piano end of his business is now looked upon as a side issue—comparison by figures.

The Pathé Shop, which moved from 218 Griswold street to 73 Broadway, is still keeping a partial stock and several sales people at the former address until the new store is completely settled and all of the customers know where the new location is at. This concern, by the way, is among those who exhibited at the Michigan State Fair the ten days ending September 6.

In connection with the Michigan State Fair at Detroit, which is always one of the big events in the motor city, there were four exhibitors, Grinnell Bros., showing Victrolas and Victor records; the Starr Piano Co., showing Starr phonographs and Starr records; Bush & Lane Co., showing the Bush & Lane "Ceciphone" talking machine, and the Pathé Shop, displaying Pathé machines and Pathé records. From reports of the men in charge of the displays the actual business done far exceeded last year and other seasons.

Wallace Brown, of the Wallace Brown Brunswick Shop, says that this has been a big year with him thus far, and that if he can secure the merchandise he expects the fall and

winter seasons to result in astonishing large sales. He reports that machine business is better than the record end, the demand far exceeding the supply.

Ed Andrew, of the J. L. Hudson talking machine department, says that he has a good stock of merchandise on hand, but that he could use considerably more. The Victrola and Sonora machines are carried in large quantities, but Mr. Andrew is finding it rather difficult to keep ahead on the popular selling models. It is reported that the Hudson talking machine department may shortly add another make of machine to its stock.

The Detroit Talking Machine Association will resume its regular meetings in October and they will continue regularly throughout the fall, winter and spring seasons. The coming year promises to see a number of big changes in methods and policies, and it will be the aim of the association to work along more uniform lines than ever before. Pending the newly-elected officers Charles Smith, of the Detroit Music Co., will act as chairman of the meetings.

The Reliable Furniture Co. on Washington boulevard recently added the Pathé line of phonographs and records, and is now featuring them very strong.

All of the jobbers report that they have more orders than they can fill, and that they are constantly after the manufacturers to ship them more merchandise, and feel certain that they will be able to take pretty good care of their customers for the holiday trade. So far they are very optimistic.

LEO HENNESSEY AT CAMP MEADE

Leo Hennessey, repairman in the phonograph department of the Tilden-Thurber Corp., has entered the army and is now at Camp Meade. He is a brother of Miss Hennessey, who is manager of the department.

Make your quarters grow. Buy Thrift Stamps.



MODEL 100

\$35, \$70, \$100, \$150, \$200, \$250

SONA-TONE

A Phonograph of Distinction with the Tone You Can't Forget

SONA-TONE *Quality* means a resonant, full, liquid tone that comes from an especially designed, all-wood sound chamber—and superior workmanship in material, finish and equipment.

SONA-TONE *Reliability* means simplicity of mechanical construction—ease of operation—and convenience and solidity of working parts.

SONA-TONE *Service* means the immediate ability of the purchaser to play all makes of records—without attachment of any sort—and to play a library of from 250 to 1000 assorted records without further expenditure.

We believe that a Sonatone eliminates—to a greater extent than any other phonograph—the surface noises of the record.

We believe that it has the same quality of resonance as exists in the Stradivarius violin.

From our sales record—previous to advertising—we believe that a SONA-TONE is a superior phonograph for retail merchandising.

SONA-TONE PHONOGRAPH, Inc.

3421 Broadway, New York City

"The music is on the record—the tone is in the phonograph."

NEEDLES

Manufactured by the
DEAN DIVISION
of the
OTTO HEINEMAN PHONOGRAPH SUPPLY CO.
INCORPORATED
25 WEST 45th STREET, NEW YORK

FACTORIES: Elyria, Ohio Newark, N. J. Putnam, Conn. Springfield, Mass.
BRANCH OFFICES: Chicago, Ill. Cincinnati, O. Seattle, Wash. Toronto, Ont.

STEEL NEEDLES

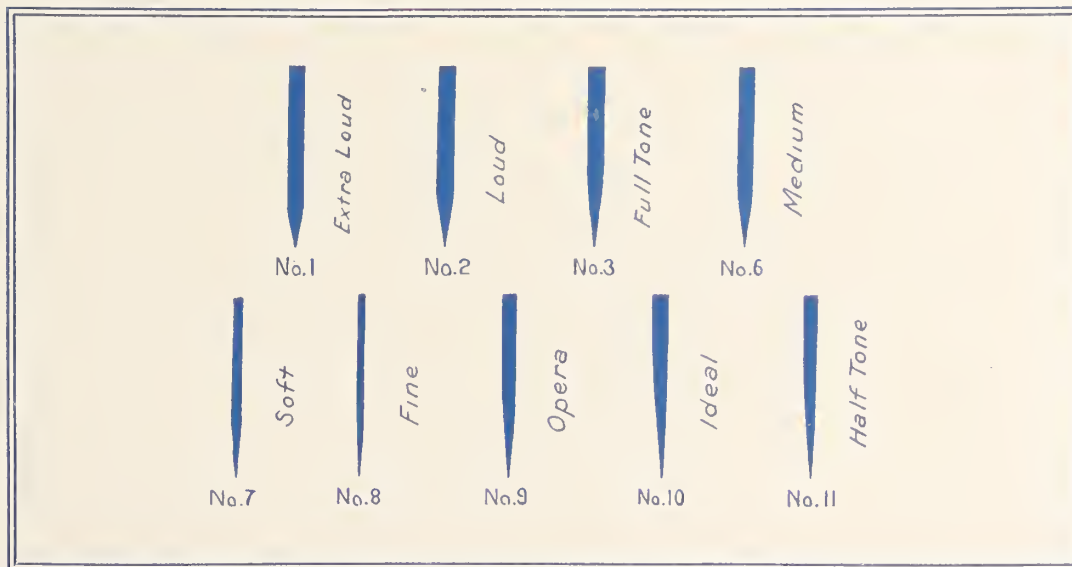

PERMANENT NEEDLES

TO PLAY PATHÉ RECORDS
Half Tone Points Full Tone Points

TO PLAY EDISON RECORDS
Sapphire Points Genuine Diamond Points



THE STOCK SITUATION SHOWS IMPROVEMENT IN BALTIMORE

Shipments Might Be Larger, But Dealers Are Thankful for What They Receive—Business Active With the Leading Concerns—Fall Outlook Is Bright Provided Stock Can Be Secured

BALTIMORE, MD., September 4.—August proved to be a good month for business with the talking machine jobbers and distributors in this city and vicinity. One of the gratifying points that has come to the dealers is the better shipment of goods, which, while not as large as the demand, still proved to be a real blessing and enabled dealers and jobbers to do a better business than they had expected.

There has been liberal advertising during the month and this has helped business. Dealers have also begun to pay more attention to their show windows, which has a tendency to attract customers and to keep business alive.

Cash sales of instruments have been reported in abundance and there is a big demand for machines over \$100. This demand shows the buying taste and also proves that there is money in circulation for musical instruments or anything musical that will bring cheer into the homes.

Patriotic and dance music appears to be in the biggest demand during the month, while there were some good selling vocal numbers. On the whole, dealers are looking forward to one of the greatest fall businesses in their experience if they are able to get the machines and records to do it with.

The Baltimore branch of the Columbia Graphophone Co. reports a big month's business, showing an increase over August of 1917. The increase was not quite as large as some of the months of the present year, but owing to the fact that shipments did not arrive promptly the month did not go ahead as much as W. S. Parks, the local manager, would like to have had it. During the month Mr. Parks made a trip to New York and also visited Washington. He managed to get goods shipped while at the New York headquarters of the company and this was the real reason for his going there.

P. W. Peck, who looks after North Carolina for the Columbia, closed a good account in J. B. Ivey, the department store, one of the most exclusive stores in Charlotte, N. C. Mr. Peck, A. B. Creel, W. T. Sibbett and Lyman Bryan, of the sales force, attended a sales meeting this week.

Two marriages take place this month, thus removing two members of the office force of Columbia. Miss Katherine Marie Carey, daughter of Mrs. Harry W. Neepier, of Govans, and who has been in charge of the information department, weds Ernest B. Kerns, of Charlotte, N. C., on September 25. The couple have al-

ready furnished their new home at Rockrose avenue, where the ceremony will take place. Miss Lettie E. Bird, one of the stenographers and the daughter of E. C. Jordan Bird, of 2206 Lynnbrook avenue, will be married on Saturday to Joseph P. Towson, son of John J. Towson, of 1731 West North avenue.

George Welzl, who is proprietor of the Highland Music Shop, the east end Columbia dealer, and William Heinekamp, the West Baltimore Columbia dealer, spent a ten-day vacation right on the Chesapeake Bay and indulged in fishing, crabbing and bathing. Jesse Nace, who looks after the troubles and straightens out the kinks at Columbia headquarters, is back after his two weeks' vacation.

Among the visitors to Columbia headquarters during the month were: H. L. Kitt, Arthur Jordan Piano Co., Washington; M. Phillips, Washington; Mr. Spencer, of Ivey Department Store, Charlotte, N. C.; H. W. Hall, Emporia, Va.; Sol. Friedberg, Grafonola Shop, Norfolk; Aaron London and M. A. Freeman, of the Hopewell Furniture Co., Hopewell, Va.; Mr. Shipley, of Storm & Shipley, Frederick, Md.; J. W. Darden, of J. W. Darden & Bro., Kenly, N. C.; Frank LeSeuer, of Lightfoot-LeSeuer Music Co., Norfolk; P. Meyers, of Meyer & Tabakin, Norfolk; Emmett Thompson, Warsaw, Va.; W. A. Bullock, of the Bullock Furniture Co., Rocky Mount, N. C.; J. J. Amerson, Wilson Furniture Co., Wilson, N. C.; W. F. Cheers, Daville; Mr. Worley, of the Worley Furniture Co., Selma, N. C.; and Mr. McDowell, H. C. Groce, Inc., Washington, D. C.

Evan Davis, one of the Columbia stars on the records, spent several days in Baltimore during the month and together with Daniel DeFoldes, visited many of the Baltimore dealers. Mr. DeFoldes is in charge of the Columbia Service Department.

W. C. Roberts, of E. F. Droop & Sons Co., Inc., Victor distributors, reports a splendid month's business for August. "It certainly was fine," said Mr. Roberts. "The business done during the month exceeded expectations. The shipments are coming in better and while not as large as we would like to have them in machines they are nevertheless satisfactory under the conditions. Record shipments are getting close to normal."

Mr. Roberts has just returned from his motoring trip and is already preparing plans for his fall and winter business. He finds the machines selling over \$100 having the big call at this time

and the record sales of "Missouri Waltz," "Sorry I Made You Cry" and "Smiles," are selling faster than it is possible to get records.

Business with the Brunswick-Balke-Cohender Co. is fine. Shipments of machines are starting to come in better and Mr. Petit, the local manager, who is just now in the South, expects to have some important announcements of new accounts to make very shortly.

W. A. Eisenbrandt, of H. R. Eisenbrandt & Son Co., Inc., Victor distributors, says business was better than they expected and there were some shipments of goods during the month. Records are coming in better, but do not equal the demand. Mr. Eisenbrandt also reports fine business in small goods, the trading in the latter being phenomenal and in a large measure due to the fitting out of many bands and orchestras for the big industrial companies about the city.

Jesse Rosenstein, for the National Piano Co., Pathé distributors, reports good business, with shipments coming in fairly liberally in both machines and records.

H. D. French, of the H. D. French Piano Co., who handle the Kimball line, reports good business with the new line and, while he has only been able to push it a little, he hopes to be able to get a better supply and says he has no trouble selling all the machines he gets hold of.

The various department stores and furniture houses with music departments all report good business and are getting ready for a busy fall.

H. W. HESS WITH G. SCHIRMER, INC.

Takes Charge as Manager of the Victor Department of This Noted New York House

H. W. Hess, formerly manager of the piano and talking machine departments of the Tilden-Thurber Co., Providence, R. I., has been appointed manager of the Victor department of G. Schirmer, Inc., 5 East Forty-third street, New York, the well-known music publishers whose Victor department is considered one of the finest in the metropolitan district. Mr. Hess succeeds Henry Broad, who resigned as manager the first of the month.

H. W. Hess is well known in piano and talking machine circles throughout the East, and his thorough knowledge of musical instrument retail merchandising will undoubtedly enable him to develop a splendid Victor business for G. Schirmer, Inc. He has a number of plans in view for the stimulation of interest in the Schirmer Victor department during the fall months, and he is enthusiastic regarding the splendid opportunities afforded for the building up of a profitable Victor department in the Schirmer institution.



Reproducer

The New Phonograph

Phon d'Amour

The New Wonder

Our patented diaphragm and reproducer give that clean, clear, snappy, mellow tone. There is no mushiness, no sharp or tinny sound. Our reproducer is suited for every purpose. It is adapted for brass band, popular song work, for violin and piano solos and for operatic sopranos, taking the high notes with such clearness and distinctness that it is the marvel of musicians and singers of renown.



Copyright, 1917, by The Fritsch Phonograph Co. Trade Mark

THE FRITZSCH PHONOGRAPH COMPANY

228-230 West 7th Street

CINCINNATI, OHIO

The VIVITONE

A Magic Little Controller That Will Add 100 Per Cent to the Tone Value of Any Phonograph

Dealers everywhere will find that the demand for this wonderful device will become universal. Why? Because no matter how little or how much a talking machine costs, this vibrant tube will sweeten the tonal qualities.

To Demonstrate the Vivitone is to Change a Prospect Into a Buyer

Every inquirer for new records may be easily won over to the Vivitone by showing them the difference in tone when the record asked for is played with and without the aid of the contrivance.

The Vivitone not only sells itself, but will *add to the demand for records.*

The VIVITONE

(Patent Pending)

A Controller That Fits All Phonographs Using Either Ordinary Steel or Tungsten Needles

Favorite Records take on New Richness of Tone with the use of the Vivitone.
Selections on the Violin, Cello, Harp, Organ, Piano and all musical instruments
are given added tone value

The Vivitone Controller produces a vivid, pure and vibrant tone. The tube is inserted into the needle-post of the sound box. Then the steel needles are inserted and may be withdrawn in the usual manner.

The Controller eliminates all blasting, harsh and strident effects of the steel needles. A heavy or loud needle is preferably used, as this reproduces the true value and color of tone of instrument or voice.

The tone is graded by the set-screw in the sound post. Set the screw tightly for loud and slightly relax it for the softer and mellow tones.

The Vivitone is unlike any other tone controller. It takes out all the "mechanics" of a record and leaves only the natural tone.

You may be sure of making new friends among your phonograph customers simply by telling them of the Vivitone. Better still, *show* them how it works. Remember, there are ten million phonograph owners who are prospective buyers of the Vivitone.

Each package contains four tubes which will play thousands of records, and retails for 50c.
Very liberal discount to dealers.

Sample FREE to Any Dealer

Hundreds of dealers who seek to sell goods that surely create Good Will have taken advantage of this offer. You, too, will find an eager response from the buying public. Write on your letterhead for Dealer's Proposition and we will send free sample at once. You'll be glad to add this easy seller to your stock of musical staples.

Vivitone Controller Company

400, 401, 402 Bell Block

Cincinnati, Ohio

NO SAD RITES FOR ARTHUR COLLINS

Prominent Recording Artist Snapped in Characteristic Mood While Bidding Farewell to His Son Bound for the Front in France

The accompanying photograph of Arthur Collins, the prominent talking machine artist, saying "good-bye" to his son, Sergeant Arthur Perry Collins, of the Medical Corps, Aviation Section, U. S. A., before leaving for France



Arthur Collins Saying Good-bye to Son

recently, indicates very strongly that partings in wartime are not always an occasion for deep grief. Mr. Collins is proud of his only son, and the smile on the faces of both in the picture indicates that the young man went into the "great adventure" with a cheerful memory of his father at home. Arthur Collins incidentally, through his records, has served to cheer up many a war-tired hero before now.

Sergeant Collins, who is not yet twenty-one years old, felt the call of duty some months ago and immediately entered the service, where he won quick promotion.

The Windsor Music Co., of Tarentum, Pa., which recently purchased for \$40,000 the building in which its store is located, reports a very excellent business in sales of Victrolas, Edison Discs and Grafonolas. Their record department is also a busy spot.

"Globe" TRANSFER NAME PLATES

SOLD BY
PAYETTE MUSIC HOUSE
ABERDEEN, WASHINGTON

STYLE 1

FROM
McC. Donald's
CONNELLSVILLE, PA.

STYLE 2

FROM
C. E. WALKER & CO.
SPORTING GOODS & VICTOR VICTROLAS
HOLYOKE, MASS.

STYLE 3

Keller's Temple of Music
(ELEVEN ENTIRE FLOORS)
EASTON, PA.

STYLE 4

SOLD BY
Easton Music Co.
HASTINGS, KEARNEY
"GRAND ISLAND"

STYLE 5

GEORGE A. MULLIN Co.
CEDAR RAPIDS, IOWA

STYLE 6

SOLD BY
WHITE PIANO CO.
FAIRBURY, NEBR.

STYLE 7

CUTS ARE HALF SIZE

Can be easily and quickly applied on

TALKING MACHINES,
PIANOS,
TYPEWRITERS,
SEWING MACHINES,
FURNITURE, ETC.

You can order any of the designs illustrated. Style 1 to 7, with your copy, as follows:

- 250—\$16.00
- 500—\$20.00
- 1000—\$27.50
- 2000—\$40.00
- 3000—\$50.00
- 5000—\$65.00

Complete transferring outfit included with every order.

Write for folder "You Need Decalcomanie in Your Business."

**Globe
Decalcomanie
Co.**

74 MONTGOMERY ST.
JERSEY CITY, N. J.

COAL OUTLOOK BETTER THAN 1917

Plenty of Fuel and More Cars for Shipping the Same, Says State Chief

If the weather next winter is not as extreme as that of last winter and if there is reasonable care taken to prevent waste and extravagance, there will be no coal shortage this coming cold season. At least so asserts D. W. Cooke, Fuel administrator for New York State, in a statement issued to-day.

In response to an inquiry Mr. Cooke reviewed the various conditions existing in the coal situation from the mine to the consumer. He reported that men are being supplied to the mines, that there is plenty of coal in the mines, that more cars are being diverted to transport coal, that there are enough barges and tow-boats, that there is a dock director, that the railroad terminals are adequate and that there are additional coal chutes as well as steaming plants for handling coal in cold weather.

The retail dealers are properly equipped to do their share and there will be no excuse for earlaps in the parlor next winter. And if the Hudson should freeze, why, there will be plenty of boats to break it up again, concludes Mr. Cooke's statement.

SOME COLUMBIA GLEANINGS

M. E. Lyle Resigns—J. P. Bradt a Visitor—Recent Visitors to Headquarters

Mervin E. Lyle, who has been associated with the Columbia Graphophone Co. for many years, and who has been connected with the company's Canadian division for the past year, resigned from the company's service this week. Mr. Lyle has accepted a splendid proposition in Baltimore, Md., where he will act as assistant to the president of one of the leading industrial concerns in that city.

James P. Bradt, general manager of the Columbia Co.'s Canadian business, was a visitor to New York this week, bringing with him optimistic reports of the business situation in Canada. The Canadian branch of the Columbia Co. is closing a phenomenal business, the volume of which is limited only by the available supply of merchandise.

J. G. Widener, who is interested in several Columbia retail establishments in the East, was a caller at the Columbia Co.'s offices on Friday. Mr. Widener is an enthusiastic believer in Columbia products, and the success that he has achieved with this line in his various stores is the result of this enthusiasm.

O. M. Kiess, manager of the Columbia Co.'s branch in Buffalo, called at the executive offices this week to plead for the delivery of Grafonolas and records to his territory. Mr. Kiess was optimistic when he spoke about business possibilities in Buffalo, but stated frankly that his visit to New York must result in the shipment of additional merchandise in order to make him perfectly happy.

J. N. BLACKMAN'S LATEST VENTURE

J. Newcomb Blackman, the prominent Victor wholesaler, who has a handsome summer home at Brightwaters, L. I., where he is one of the prominent citizens, has been instrumental in organizing the Brightwaters Holding Corp., with capital stock of \$100,000, and designed to control and protect the casino and the bathing facilities at Brightwaters for the mutual benefit of the inhabitants of that suburban resort.

TELLS STORY OF PROSPERITY

Geo. C. Hively, of the talking machine department of the Eastern Outfitting Co., San Francisco, Cal., reports a very substantial increase in business over last year, some months running over 50 per cent. This company is looking forward to an exceptionally fine holiday business and is planning accordingly to this end.

You Can Make Good Profits

in a legitimate manner and give the customer

Magnificent Value

in the



Phono-Grand

It is a splendid reproducing electric-controlled player piano and a superior

Edition DeLuxe

Phonograph

All in One

We know it's to your best interests to get full particulars and to inquire about exclusive territory—NOW!

Full descriptive literature on application.

The
**J. P. Seeberg
Piano Company**

209 South State Street
CHICAGO, ILL.

WORLD PHONOGRAPH CO.

OFFICERS

FRANK BAACKES, President
C. K. ANDERSON, Vice-Pres.
ERNEST C. COOK, Sec.-Treas.

MANUFACTURERS

The Instrument of Quality

GENERAL OFFICES AND FACTORY
736-738 TILDEN STREET
CHICAGO, ILL.

DIRECTORS

FRANK BAACKES
Vice-President American
Steel & Wire Co.
C. K. ANDERSON
President American Wire
Fabrics Co.
J. P. SHERLOCK
President Illinois Nail Co.
F. E. MORTON
Manager Acoustic Department
American Steel & Wire Co.
ERNEST C. COOK
Secretary and Treasurer

*Send for our new
design catalogue*

TRADE CONDITIONS IN SEPTEMBER

Volume of Business Will Be Gauged Largely by Amount of Machines to Be Obtained

INDIANAPOLIS, IND., September 9.—The outlook for business this fall in the Hoosier capital is regarded as very encouraging by talking machine dealers here. The only cloud on the horizon seems to be the fact that a sufficient number of machines and records will not be allotted to this territory.

"The amount of business that will be done," said one dealer, "will be gauged largely by the amount of machines we can obtain."

As the stalwart youths are going one by one to the defense of their country, the salesgirl and saleswoman are edging their way into the talking machine stores where there are few young men salesmen now.

A. H. Snyder, manager of the Edison Shop, has put on several saleswomen to take the places of young men who have gone into the service. He said the Edison Shop is anticipating one of the best seasons this fall as far as business is concerned.

The selective draft continues to step in and take a man here and there. Harry Diehl, advertising and publicity man for the Stewart

Talking Machine Co., wholesale distributors of the Victor line, has gone to Camp Taylor, Ky. Fred Fisher, of the order department of the same company, also has gone to camp.

Ben L. Brown, manager of the wholesale department of the Columbia Co., was pleased at the recent visit of Frank K. Pennington, assistant general sales manager. Cupid stepped into the Columbia and Brunswick organizations in the last few weeks. Robert D. Duffy, assistant manager of the Columbia, was married to Miss Ruth Stickler, of Louisville, Ky. On condition that she still continue her work as bookkeeper for the Brunswick Shop, George F. Standke, manager, gave his consent to Miss Rhoda Porterfield to marry H. C. Barnes, in the advertising department of the Indianapolis News. The marriage of Mr. and Mrs. Barnes follows a romance which had its inception in Mr. Barnes calling on Mr. Standke for advertising accounts.

W. E. Kipp, of the Kipp Phonograph Co., wholesale dealers in the Edison line, has returned from a trip to the Edison factory at Orange, N. J.

Frederick Aylesworth, manager of the Vocalion department of the Aeolian Co., combined a business and baseball trip to Chicago to see the opening game of the world's series.

J. L. Peters, manager of the retail branch of the Columbia Co., said he expected a good fall business—if he could get the machines.

INTRODUCE CIRCUS' ORGAN RECORD

A Novelty Record Introduced In the October Supplement Issued By the International Record Department of the Columbia Co.

The international record department of the



Illustration of Circus Organ Record

Columbia Graphophone Co. announces in the regular October supplement of new records a novelty record featuring two selections recorded by a circus organ. This is the second record introduced by this department in the regular monthly supplement, and, judging from the advance orders, this innovation is a success.

This circus organ record was made abroad, although the music is the same well-known variety which "accompanies" our own American circuses and our popular merry-go-rounds. This record will not only attract the attention of the young folks, but also bring back pleasant memories to the young "grown-ups."

Reputation is a desirable thing, but character is the real thing to seek for, and a man's inner consciousness should serve as a guide to the distinction between the two.

CRYSTAL EDGE MICA DIAPHRAGMS

**M
I
C
A**

Let us send you samples *today* of our diaphragms and you will readily understand why the best talking machines are equipped with *Crystal Edge Mica* diaphragms exclusively.

We use only the very finest selected mica, the best diaphragm material in the world.

PHONOGRAPH APPLIANCE CO., 109 West Broadway, NEW YORK

HANDSOME NEW HOME OF THE PENN PHONOGRAPH CO., INC.

Now Occupying Well-Equipped Quarters at 913 Arch Street, Philadelphia—Four Floors Efficiently Laid Out for Various Departments—A Great Organization for Wholesaling Victors

PHILADELPHIA, PA., September 5.—After twenty years of uninterrupted business at their former address, 17 South Ninth street, the Penn Phonograph Co., Inc., have moved to their new location at 913 Arch street, this city, but a short distance away. The growth of this firm has been continuous and increased space for increased business has been an absolute necessity in order that "Penn Service," which has been made to mean so much, might be kept to its high standard.

The Penn Phonograph Co., Inc., occupy four floors in this modern fireproof building on this busy thoroughfare. Previous to their occupancy each floor had been efficiently laid out with the idea in mind of handling a maximum volume of work with unnecessary labor eliminated. The basement of the new Penn Building is devoted to storage purposes entirely. The shipping department occupies the first floor, which allows the utmost convenience in receiving and shipping goods and does away with the elevator hauls to upper floors. As the Penn Phonograph Co., Inc., cater to the wholesale trade exclusively, they have no retail warerooms and are thus able to give the first floor over to shipping. It is also planned to devote the rear of this floor to the storage of cabinets.

On the third floor the offices of the company have been attractively fitted up. The executive offices at the front to be occupied by T. W. Barnhill, president and manager of the company, and Henry F. Miller, secretary, together with their assistants. The traveling sales staff will also have their headquarters on this floor, E. E. Hipple, L. P. Brown and L. Worrell constituting this staff. To the rear of these offices is the monthly record rack followed by the surplus racks to accommodate 100,000 records. At the extreme rear is the repair department.

The entire fourth floor is given over to records and is in charge of T. Ralph Clark, assisted by Victor Moore, specialist on Victor record order systems. The racks on this floor have accommodations for some 450,000 records. They are constructed and laid out with efficiency paramount and have, according to Mr. Barnhill, "the strength of Gibraltar." Several hand trucks have been put in service in this department to facilitate the gathering records to fill orders in hand. The building is modern in every respect, fireproof, and is equipped with an outside staircase for further protection. Elevator service is provided for the upper floors. When daylight wanes the building is attractively lighted by the indirect system.

In a removal announcement sent to the trade there is printed their business creed, which undoubtedly is the secret of their singular success and which we quote herewith:

"Our Creed—We believe that a strict adherence to the equitable distribution of Victor

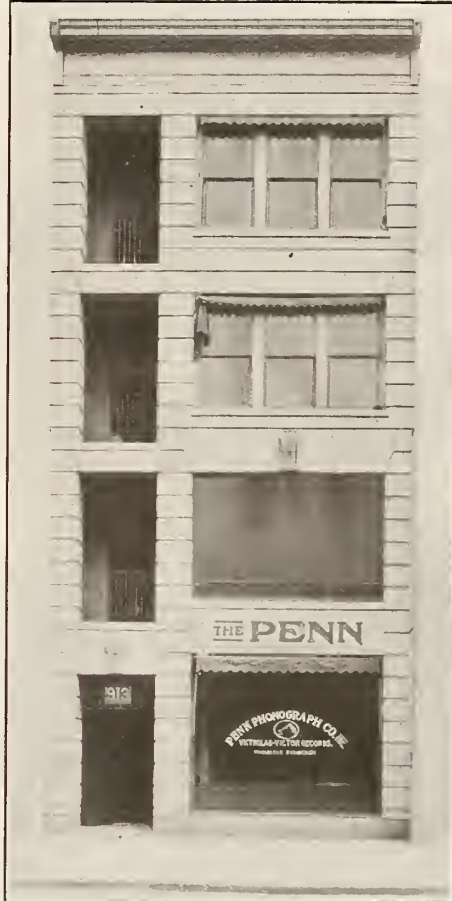

New Home of Penn Phonograph Co., Inc.

product will enable us to continue to satisfactorily serve our dealers, many of whom we have served without interruption for twenty years. Their confidence in us intensifies our obligations to them, makes us more determined to increase our efficiency and to further cement the existing bond of friendship and satisfaction, by constructive business methods. Courtesy, efficiency, integrity and ability are the powers behind our service, which we believe will justify a continuance of your confidence and dignify our relations."

Facing this creed is "The American's Creed,"

which patriotic utterance is familiar to many. Mr. Barnhill and Mr. Miller state: "We have a strong affection for our former location, where we spent twenty years in pleasant intercourse with our Victor dealers. We will endeavor to make them feel at home in our new building and want them to enjoy with us the pleasures and advantages which these quarters provide."

"FAIR SEX" IN RECORD DEPARTMENT

New York Talking Machine Co. Utilizing Women to Take Place of Men Who Are in the Service—Roy J. Keith's Chicago Visit

Roy J. Keith, vice-president and general manager of the New York Talking Machine Co., Victor wholesalers, spent a few days in Chicago recently, attending the regular quarterly meeting of the Board of Directors of the Chicago Talking Machine Co. and the New York Talking Machine Co. While in Chicago Mr. Keith was glad to have an opportunity of welcoming one of his former associates, W. C. Griffith, who was formerly assistant sales manager of the Chicago Talking Machine Co. Mr. Griffith is now a corporal in a machine gun corps of the U. S. Army and visited Chicago on his last furlough before leaving for an Eastern port and embarking for France.

In order to partially meet the unprecedented demands made upon its sales and clerical staffs by the departure of thirty-eight men for Uncle Sam's service, the New York Talking Machine Co. has engaged a number of young ladies, who act as clerks in the record stock department. The members of the "fair sex" have entered upon their new duties with vim and enthusiasm and are working indefatigably to give efficient service to the company's dealers.

W. H. Nolan, of the Louis Buehn Co., Philadelphia, Pa., Victor wholesalers, was a visitor to the offices of the New York Talking Machine Co. last week, bringing with him pleasing reports of the general business activities in the Quaker City.

NEW BAD CHECK LAW IN NEW YORK

New Statute Defines Negotiation of "Not Good" Checks as Larceny

Under the new statute designed to increase protection against bad bank drafts and checks which became effective in New York State recently, the negotiation of "not good" checks, with intent to defraud, is defined as larceny and punishable accordingly. Under this law it will not be necessary to prove that money or property was obtained in order to establish the commission of a crime. Acts similar to the New York law are now on the statute books of several other States.

THE RESURRECTONE



Read the Trade Mark carefully, hear the machine, and you'll agree that it is truly
The World's Musical Instrument
Improves All Records

(Trade Mark Registered)

\$125

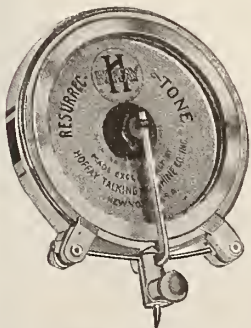

"A music lover will never hesitate to pay \$10 for a reproducer that trebles the musical value of his records."

Is the only reproducer giving sounds proper intonation and rhythm, combined with such naturalness and "warmth" of color as to make them a true *resurrection* of the original.

Using loud tone needle it gives greater clearness and volume of sound and fully 50% less surface scratch than any other reproducer; with a soft tone needle or fibre needle the beauty of the reproduction will satisfy a musical critic.

Prominent dealers, upon testing this supreme reproducer, state that they had not heard their records before. Superb in voices—colossal in instrumental, orchestras and bands. The "Resurrectone" makes your records more saleable.

One model fits Victor Victrolas, Sonoras, and attachment for Edison's. Other model fits Columbia machines exclusively. Send for samples. Unless our claims are justified, return at once. Fully guaranteed. Net dealers' prices, \$5.40 nickel plated; \$6.75 gold plated. Retail prices, \$10 and \$12.50, respectively.

Write for exclusive territory proposition.



Height, 44
Width, 20 1/4
Depth, 20 1/4

Other Models
\$175, \$225, \$275

HOFFAY TALKING MACHINE CO., INC. 3 WEST 29TH ST. NEW YORK CITY

NINETY PER CENT
of
**New Edison
Diamond Amberolas**
placed on trial are sold

An instrument on trial in the home generally has to stand comparison with at least one of its competitors. The best satisfied Amberola owners are those who purchased after such a test.

A thoroughly and permanently pleased instrument owner is a good record buyer.

Record sales mean profits for you.

THOMAS A. EDISON, Inc.
Amberola Department
ORANGE, N. J.

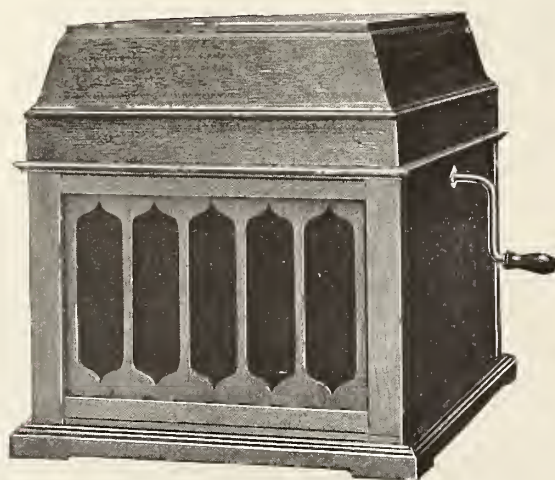

THE NEW EDISON DIAMOND AMBEROLA
MODEL 50

You can make a clean sweep with the New Columbia Non-Set Stop. Nothing like it ever seen on a phonograph.



Columbia Graphophone Co.
NEW YORK

A LIVE PUBLICITY CAMPAIGN

The Lair Co., Charleston, Mo., Adopts Clever Idea in Advertising the New Edison, Pianos and Other Lines Carried by That Concern—Gets Inspiration from Talking Machine World

The Lair Co., piano, phonograph and house-furnishing dealer, of Charleston, Mo., has built up a most substantial business through the adoption of original sales and publicity methods, a recent instance of which is the presence in local newspapers of a full page headed: "Lair's Store News," five columns of the page are given over to straight advertising, with the Apollo player-piano featured strongly. The interesting feature of the ad, however, is one column headed "Editorial Comment," in which appear small paragraphs regarding the visitors to the store, thus making purchasers of special note and news items about the various lines handled by the house. One paragraph in a recent ad, for instance, listed several purchases of Apollo player-pianos, while another paragraph advised the early purchase of New Edison phonographs in order to take advantage of present prices, bound to advance.

"Lair's Store News" appears once each week, and is sufficiently interesting to make a ready appeal to readers. The Lair Co. has ascribed much of its success in the creation of new and original publicity plans to The Talking Machine World, and took occasion to say:

"This letter is to give you a 'pat on the back' by saying that you are getting out a splendid paper and the furniture dealer who does not get enthusiasm and information from its pages that will make him a better merchant must be a fellow who does not read it.

"We try to gather the cream from the plans you publish that have been successfully used by firms in various parts of the country and have tried a number of them with success."

AN ATTRACTIVE WINDOW DISPLAY

Dealers Service Department of the Columbia Co. Arrange Display of October Records

The dealer service department of the Columbia Graphophone Co., New York, has prepared for



Attractive Columbia Window Display for October

the use of Columbia dealers a very attractive window display featuring the October records. This display is somewhat different from the series heretofore presented, as instead of using a combination of fine art work and effective poster design, the October display presents a series of outlined multi-colored figures on each card, constituting an idea with an effective sales punch. The outstanding feature of the display is the unusually large number and varied assortment of cards which are so designed and arranged as to contain the names, numbers and prices of nearly the entire October list. While in some of the windows that are available for use by the dealer in the small town the display may be too large as shown complete, it retains its effectiveness even when reduced by two or three units, which may be held and used to replace other cards of the display.

The display is lithographed on eight-ply coated cardboard in nine brilliant colors, and is complete in all details, including easels, etc. The large figure is particularly impressive, as it bears in the heading the pertinent suggestion that "Everyone Needs a Grafonola in the House." A balancing window poster lists the latest dance hits and other cards and cutouts serve to draw particular attention to individual records and individual artists represented in the October list.

LOUISIANA A LIVE TRADE CENTER

W. H. Booth, of Booth Furniture & Carpet Co., Shreveport, Doing Well With New Edison

A recent visitor to New York was W. H. Booth, of the Booth Furniture & Carpet Co., Shreveport, La., a prominent Edison dealer, who is now touring the Eastern States by automobile, accompanied by his wife and son.

Mr. Booth spoke most enthusiastically regarding business in his section of the country and declared that although a carload of new Edisons had been delivered to him recently by his jobber, the Diamond Music Co., of New Orleans, he had already wired for another carload, as he needs well over one hundred new Edisons for delivery early this month.

The Booth Furniture Co., although located in Shreveport, with only 40,000 population, is said to possess the largest and finest store of its kind in the State of Louisiana, even including New Orleans, which is ten times Shreveport's size.

The Mutual
TONE ARMS & SOUND BOXES

Dealers

If you want the best, be sure that the machines you handle are equipped with

MUTUAL

TONE ARMS AND SOUND-BOXES

Mutual Talking Machine Co., Inc.
145 West 45th Street, New York

The BEST TALKING MACHINE NEEDLE
On the Market—Packed in Counter Salesman

VIOLAPHONE
PHONOGRAPH NEEDLES
EACH NEEDLE WILL PLAY 10 RECORDS

50 Needles to a box and they retail at 10c. per Box.
60 Boxes to a package \$6.00.
This package costs you \$3.90 net.

Your profit is \$2.10 and your customer gets a needle that will give satisfaction.

The Fred. Gretsch Mfg. Co. 60 Broadway
Brooklyn, N.Y.
Manufacturers of Musical Instruments
Canadian Wholesale Agent, H. A. BEMISTER
10 Victoria St., Montreal, Can.

WAR WORKERS BUYERS OF TALKING MACHINES IN BUFFALO

Dealers Report Increased Demand From This Source—August Business of Satisfactory Volume—New War Tax Discussed—Machine Shortage Still Evident—Women Added to Sales Forces

BUFFALO, N. Y., September 3.—Buffalo dealers are sounding the warning that the Government war tax will become effective shortly and that to buy talking machines now at the present prices means a substantial saving. This warning is being heeded by many prospective customers and has a stimulating effect on the trade. The dealers are emphasizing the fact that besides an advance in prices there will be a positive shortage of machines. Reports of August trade are favorable, a dominating feature being a heavy demand for models at \$75 and upward.

The trade of munition workers flows without interruption to the stores. The business of these customers is regarded as more profitable than that of the aristocratic or so-called "carriage trade." Many laborers are earning two and three times more than store or factory workers and are proving prodigal spenders. Unlike conditions in the old days, a customer handicapped with a foreign accent, especially if he bears evidences of toil, is sure to receive courteous, snappy service from talking machine salesmen.

The Utley Piano Corp. announced an advance in the price of New Edisons on September 1. The company emphasized the advantage of buying before that date. Neal, Clark & Neal have sent broadcast the word that "genuine Victorlas will advance in the very near future."

Buffalo dealers are not regarding with smug contentment their chances of getting a sufficient supply of talking machines for their holiday trade. They are consoled with the belief that if there is a great shortage of instruments all the stores will be "in the same boat."

The office of the Hoffman Piano Co. has been removed from the front to the rear of the store. At the front phonograph demonstration and record rooms have been built. This concern handles the Sonora and Brunswick machines.

"Our August business was curtailed considerably because of the machine shortage, in particular," was the report of the Buffalo branch of the Columbia Graphophone Co. "Last month produced lots of orders but we weren't able to take care of them. We have notice of shipment of several carloads of new model machines. These will be disposed of to fill back orders in the trade. Our record business was unusually good, showing a healthy increase over August of last year. Our Pershing record continues to sell exceedingly well."

Several young women have joined the sales forces of talking machine stores in this city. It is expected the number of saleswomen will increase after the men register under the new eighteen-to-forty-five-year rule of the Government and are called to do war work.

O. M. Kiess, Buffalo manager of the Columbia, has returned from a fishing trip. On account of a rush of trade he has refrained so far from relating to his co-workers at the branch one of his promised "fish stories." With all the necessary embellishments these will come later.

John Schuler, Sonora dealer, is planning to exhibit some of his "prize vegetables" at the fall fair at Hamburg, N. Y. They were grown on his farm on Ellicott Creek, near this city.

Private Harold Verbeck, secretary and treasurer of the Verbeck Musical Sales Co. of this city, is with the Motor Mechanics at Gerstner Field, Lake Charles, La. In a recent letter he says he is in excellent health and hopes to be overseas shortly. The Verbeck Co. handles the Columbia and Delpheon talking machines. George H. Verbeck, president, and G. F. Pinzel, vice-president of this firm, have returned from their vacations.

It is said that the Buffalo office of the State employment bureau must be consulted by a young man before he applies for a position in a local talking machine store. At the bureau he is likely to be advised to do war work of some kind.

Manager Gardner, of J. N. Adam & Co.'s talking machine department, has closed his fiscal year with a considerable increase over the preceding year's trade. Ray Ottinger, head repair man for this concern, is at Cambridge, Mass. He is a member of Co. 31, U. S. Navy Radio School.

M. Truda has permanently closed his retail piano store at 238 West Ferry street.

Many talking machine records and other merchandise have been stolen from freight cars in the local railroad yards. The thieves are being rounded up and punished by the Federal authorities.

George Goold, of Goold Bros., has returned from a vacation trip. This firm has plenty of Sonoras to supplement its Victrola stock. Instead of seeking long-term business Goold Bros. are going after cash contracts.

As a believer in early buying Charles Hereth has received a heavy shipment of New Edisons for fall business.

To conserve labor several of the talking machine stores are making only one delivery a day. This is at the request of the War Industries Board at Washington, D. C.

Effective window displays for "food conservation week" were featured by Victor & Co., and Adam, Meldrum & Anderson Co., who handle the Pathéphone, and the William Hengerer Co. and J. N. Adam & Co., Victor dealers.

There is plenty of good business in sight for Niagara Falls talking machine dealers because the Government will spend \$1,250,000 there in building hundreds of new homes for war workers.

Fraudulent advertising to attract trade is becoming as scarce in the talking machine business as admirers of the Kaiser. In the past the public has paid dearly for its knowledge that despite the alluring baits offered by "get-the-money-quick" dealers, it is really impossible "to buy something for nothing."

H. W. FILDES SUCCEEDS H. W. HESS

Becomes Manager of the Piano and Talking Machine Departments of the Tilden-Thurber Co., Providence, R. I.—Capable Executive

PROVIDENCE, R. I., September 5.—Herbert W. Fildes has been appointed manager of the piano and talking machine departments of the Tilden-Thurber Co. of this city. Mr. Fildes succeeds H. W. Hess, who has left for New York to assume a managerial position in that city. The Victor and Aeolian-Vocalion lines are handled in the Tilden-Thurber department, and Mr. Fildes, who is well known in talking machine circles in the East, expects to institute an aggressive campaign in behalf of these two lines. Before joining the Tilden-Thurber staff Mr. Fildes was associated with the Vocalion Co. in this city, and is therefore thoroughly familiar with the retail situation in Providence.

"KNIGHTS" APPRECIATE GIFT

W. J. Mulligan, Chairman of K. of C. Committee on War Activities, Writes Otto Heineman

Otto Heineman, president of the Otto Heineman Phonograph Supply Co., New York, received recently an interesting letter of thanks from Wm. J. Mulligan, chairman of the Committee on War Activities of the Knights of Columbus. Mr. Heineman recently presented this committee with fifteen Vanophones, together with a supply of "OkeH" records, needles and sapphires, and Mr. Mulligan, in behalf of the committee, wrote as follows:

"This will acknowledge receipt of the fifteen Vanophones, records and sapphires for which, on behalf of the committee, I want to express sincere thanks. Respectfully yours, (Signed) Wm. J. Mulligan, Chairman."

Mr. Heineman has quite a number of letters on file from military, fraternal and social organizations throughout the country, expressing their appreciation of the generosity of the Otto Heineman Phonograph Supply Co. in providing them with machines, "OkeH" records and supplies. At the present time, the gifts presented by Mr. Heineman are in use in many points in Cuba, where the U. S. Marines are located, and also at different aviation fields in this country, as only a short while ago Mr. Heineman gave machines and a supply of records to several of the regiments in training in the aviation camps.

EASY TO MAGNIFY TRIFLES

It is easy to magnify trifles—to worry about the possibility of unkind criticism from others. It is easy to find little flaws in the amber and from a focusing of attention on these to take such a distorted view of the amber that its clear yellow light will be no longer beautiful. To be happy, be glad of the chance life offers you for work and achievement.



Hire the Man Who Can Do It Better

—That's how Carnegie says he got there

CABINETS BUILT FROM YOUR BLUE PRINTS

Or will submit designs if desired

—LET BROWN DO IT RIGHT—

—and it'll be done right for you to turn over the most profit at the least expenditure of time, trouble and producing effort.

Prices fitted to your selling proposition.

Building cabinets is my specialty—I've put all my time into it for years. I've accumulated a valuable experience that's at your command.

Why Worry Along on a Hunch—
My Knowledge is a Sure Thing
Get in Touch With Me Today

CHAS. C. BROWN

350 E. Water Street Milwaukee, Wis.

PROMPT SHIPMENTS

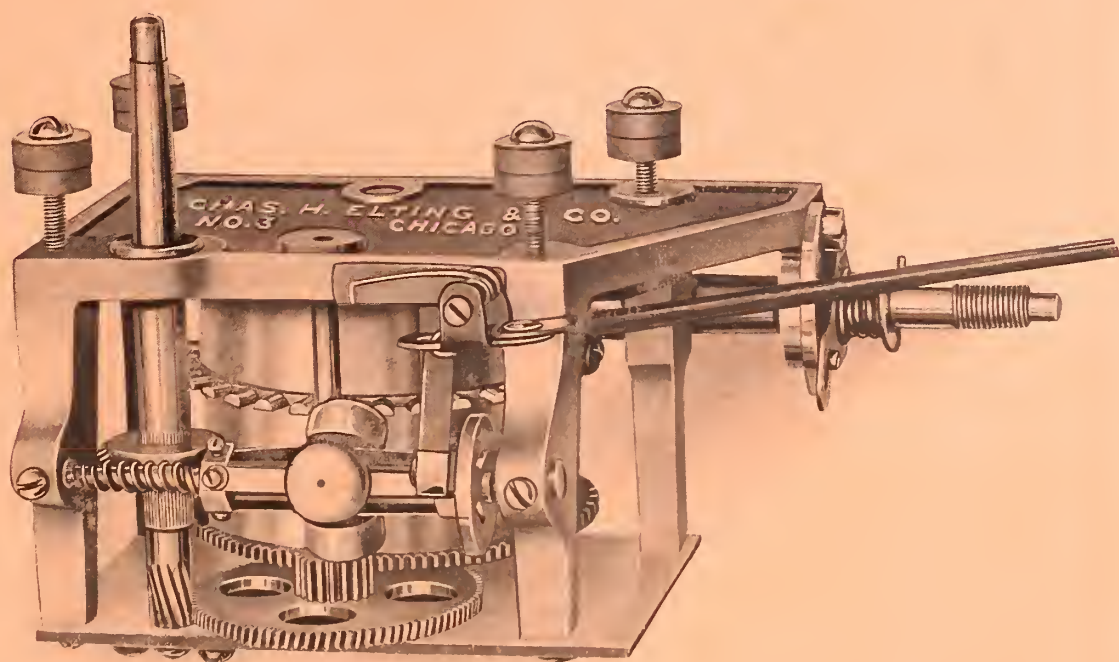

No. 3—Cast Frame, Ball Bearing, Double Spring Motor Playing about four 10" Records



No. 2—Universal Ball Bearing Tone Arm with Extra Large Reproducer

CHARLES H. ELTING & COMPANY
1516 South Wabash Avenue
CHICAGO

Canadian Distributors: Canadian Symphonola Co., Ltd., 31 to 37 Brock Ave., Toronto, Ont.

HOW MICKEL BROS. CO. ENTERTAINED

Victor Jobbers Have a Number of Dealers as Their Guests at Luncheon in Des Moines—Also Visited Iowa State Fair

DES MOINES, IA., September 8.—The regular annual Iowa Victor Dealers' convention of August 27 and 28 was postponed, owing to the opinion of the executive committee, due notice of which was sent to each member of the association by the secretary.

The executive committee expect to call a convention some time later in the fall, at which time the necessary information sought from the Victor Co. will be forthcoming as to the future output and possibility of greater deliveries of Victrolas and records, and at which time the original program instituted by the membership committee can be safely carried out. Furthermore the co-operation of the Victor Co. will be better assured later on.

Notwithstanding the fact of the postponement of this convention, Mickel Bros. Co., of this city, through the general manager, Geo. E. Mickel, extended an open invitation to each and every member of the association, as well as other dealers not members, to visit Des Moines during the Iowa State Fair week, Mickel Bros. Co. offering their office as headquarters for any of these dealers. Also an invitation was extended to each dealer and member of the association to lunch with the management of Mickel Bros. Co. Several members took advantage of this invitation, they being Chas. Bawden, Lake City, Ia.; P. K. McKee, Indianola, Ia.; Miss Laing, of John Mesing Co., Algona, Ia.; E. E. Hobbs, Peacock & Baxter, Atlantic, Ia.; Walter Bussler and assistant of the James Black Dry Goods Co., Waterloo, Ia.; Mr. Schultz, of the Schultz Drug Co., Belmond, Ia.; Mr. Strombeck, of the Strombeck Drug Co., Maxwell, Ia.; E. M. Lilves and wife, Grand Junction, Ia.; Melvin H. Porter and family, Jewell, Ia.; R. A. Nietzel, manager of Lohr & Bristol, of Muscatine, Ia.; Miss Fannie A. Nichol, Mt. Ayr, Ia.; Mr. Osborn, of Osborn Pharmacy, Knoxville, Ia., and the Audubon Music Co., of Audubon, Ia.

Quite a number of other dealers answered the invitation and stated they regretted that, owing to the shortage of labor and their inability to get away, they were not able to take advantage of the courtesy extended by Mickel Bros. Co.

HYATT CO. IN NEW QUARTERS

PORTLAND, ORE., September 6.—Twelve demonstrating and machine rooms will be ready for customers in the fine new store which the Hyatt Talking Machine Co. has secured at 350 Alder street, where the firm is now engaged in moving. Every comfort and facility will be provided. Well-lighted rooms and a system of ventilation which will change the air in each room every ten minutes will be part of the modern equipment of the new store. The firm will continue to handle the three standard lines—Victrola, Edison and Columbia. A complete and comprehensive stock of records will be carried by the store. Much interest is being evinced by the many customers who deal exclusively at Hyatt's and all the talking machine dealers, who have the highest regard and respect for E. B. Hyatt, the manager, wish him success in his fine establishment.

THE ECHO OF AN ATTRIBUTE

"A tribute is usually the echo of an attribute," says Edward Earle Puriton, who has written a great deal on salesmanship, and when you think it over, isn't there a great deal of meat in this aphorism?

"Big enough to serve you; not too big to appreciate you." With this slogan a bank in Spokane assures its customers of its adequate facilities for handling their business in a personal way.

GUTTENBERGER GOES TO MOBILE

Will Have the Management of the Talking Machine Department of the Reynolds Music House in That City—Popular in the Trade

ST. LOUIS, Mo., September 8.—Emmett W. Guttenberger, manager of the Vocalion department at Aeolian Hall, will sever his connection with that company September 15 to take the management of the talking machine department for the Reynolds Music House at Mobile. Mr. Guttenberger came here from Mobile twenty-six months ago to take the management of the department here, succeeding Harry Levy, now wholesale manager of the Chicago Vocalion department. Mr. Guttenberger began his talking machine career here with the Columbia Co. about fourteen years ago and later served the Columbia Co. at many points, leaving that service in 1912 to go with O. K. Houck at Memphis. From there he went to Mobile. He is attracted back to the Gulf town by the war industries prosperity there. At Mobile he will sell Vic-

tor machines. His successor has not been named. Harry Levy was here from Chicago the first week of the month.

HEMPEL SINGS FOR THE RED CROSS

Frieda Hempel's concert for the Red Cross brought more than \$2,200 to the Lake Placid Chapter and the Lake Placid Club Auxiliary, under whose auspices it was given. Not only the famous Edison artist herself, but her photographs and the re-creations of her exquisite "voice of gold and magic," shared in the success of the concert at the club September 1.

An autographed photograph of the Metropolitan soprano, as "Marta," holding "The Last Rose of Summer," brought \$500, and one of her signed records of the immortal melody started the \$250 receipts from that source. A small post card photograph of the singer as Marie in "The Daughter of the Regiment," brought \$25 and other copies sent the sale up to \$139. Miss Hempel was assisted by the Boston Symphony Septet.

FAULTLESS CASTERS



The Weight Rests Here

Perfect construction and inviting in appearance—**FAULTLESS** Casters are still more pleasing in actual use, in moving phonographs.

Their gentle, easy moving qualities are most essential and agreeable.

Send for Samples

"Move the **FAULTLESS** Way"

Full Size C-65

FAULTLESS CASTER COMPANY
Evansville, Indiana

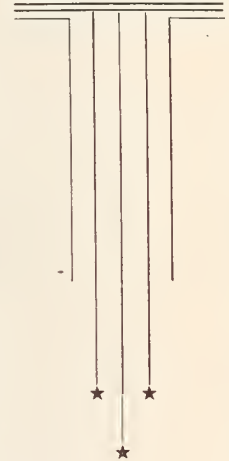

WHOLESALING EXCLUSIVELY



Victrolas-Victor Records
the 2 Largest Wholesalers
IN
the 2 Largest Cities

CHICAGO
Talking Machine Co.
12 N^o Michigan Ave.
CHICAGO

NEW YORK
Talking Machine Co.
119 W. 40th Street
NEW YORK



FROM OUR CHICAGO HEADQUARTERS

E. P. VAN HARLINGEN,
Manager

World Office
Republic Bldg., 209 South State St., Chicago
Telephone: Wabash 5774

CHICAGO, ILL., September 10.—With the opening of the big War Exposition here this week the people of this city as well as those visiting from adjacent towns are for the first time being given actual demonstration of just what is meant when "Music in the War" is spoken of. Due to an idea suggested by a representative of The Talking Machine World to Mrs. Anne Shaw Falkner Oberndorfer, manager of the Western branch of the National Bureau for the Advancement of Music, the visitors to the big Exposition were given an opportunity to see just where the player-pianos and player rolls, talking machines, records and other musical instruments that they were donating to the cause of "Music in the War" were being sent and how they were received by the boys at the front as well as in the various camps. The idea as originally set forth by a representative of The World was to construct and equip with musical instruments a replica of the dugouts in actual use on the battle fronts. This idea was not carried out according to original plans for a trench dug out, but the plan was so favorably received by the men in charge of the Exposition that they issued orders for the establishment of ten music booths throughout the showgrounds. Due to the good work of Mrs. Oberndorfer, booths were established in the Y. M. C. A., K. of C. and Salvation Army concessions as well as several other places, and as a result of this actual demonstration more music and musical instruments have been pouring into Mrs. Oberndorfer's office in room 819 Fine Arts Building than ever before.

The Trade Situation Reviewed

As for the trade situation here there is not much to speak of other than what has been said in previous issues of The World. Both the machine and record situation occupy the same position as last month, that is, the records, while coming in a little steadier than heretofore, are not being received in quantities large enough to fill the demand.

Locally there is much activity with the wholesale trade. Many new concerns are springing into existence here and as a natural result many new machines are appearing on the market. Some of the instruments are decidedly original and give every evidence of being favorably received by the public.

Griffith P. Ellis Promoted

At the annual election of officers of both the Chicago Talking Machine Co. and the New York Talking Machine Co., Griffith P. Ellis, who is sales manager of the Chicago concern, was elected secretary of both establishments. The following re-elections took place also: A. D. Geissler, president; Roy J. Keith and D. A. Creed, vice-presidents. Due to his promotion Mr. Ellis has been receiving the congratulations of his many friends in the trade who regard him as one of the hardest workers and best fellows who ever entered the talking machine game. Six years ago Mr. Ellis began with the sales department of the Musical Instrument Sales Co., of New York, and after a while was transferred to the Victor department of the Scruggs-Vandervoort & Barney Co., of St. Louis, as manager. From there he went to Louisville, Ky., to open the Victor department of the Stewart Dry Goods Co. of that city. In the meantime his work attracted the attention of A. D. Geissler, president of both the Chicago Talking Machine Co. and the New York Talking Machine Co., who offered him the position as sales manager of the Chicago concern. Mr. Ellis accepted the position offered by Mr. Geissler and was so successful in his new undertaking that two years ago he was elected a director of both companies. His present office, that of secretary, will in no way interfere with his former duties as sales manager and director, as he will continue to discharge the duties of these positions.

New Cheney Shop

A new talking machine shop which is known under the title of the Cheney Shop was formally opened to the trade of Minneapolis on Saturday, September 7. These new warerooms are said to rank among the most beautiful of any in the city and will be under the personal supervision of L. L. Lawson, as manager. Mr. Lawson, while recently paying a visit to the Chicago headquarters of the Cheney Talking Machine Co., stated that the sales of Cheney talking machines had grown to such proportions in Minneapolis that it was decided by the company to open this new branch, wherein the Cheney phonograph would have exclusive representation in a retail way. The new store is located near the corner of Fifth street and Market avenue.

Another well-known Cheney man who visited Chicago recently was G. G. Robinson, the Cheney wholesale representative who covers the territory in western Illinois and Missouri. Mr. Robinson, while a young man, is old in experience and knows the talking machine game thoroughly. At one time in his career he traveled the northern Ohio territory for the Columbia Graphophone Co. as wholesale traveler. He stated that the business in his territory was going on in a very satisfactory manner and that the trade outlook, as judged from the opinions of the various retail dealers throughout his section, is very promising.

Corporal W. C. Griffith Visits

Corporal W. C. Griffith, U. S. A., who was formerly assistant sales manager of the Chicago Talking Machine Co., while in Chicago on a short furlough recently, paid his respects to his many friends in the trade here. Since enlisting in the army Corp. Griffith has been stationed at Camp Wheeler, Macomb, Ga. After spending several days here he paid his mother and family a visit at the family home in Indianapolis. He stated that he expects to be actively engaged in overseas duty within a few weeks.

"Good-bye, Boys"

H. E. Whitman, formerly floor salesman for the Chicago Talking Machine Co., but now manager of the Victor department of the Pierson Piano Co., Indianapolis, was a Chicago visitor this week. Mr. Whitman surprised his friends of the Chicago trade by introducing a beautiful, blushing young lady, who became his bride on August 3. The cigars were on him, of course, but the congratulations were on the crowd. Bless you, my children.

Establishes Headquarters Here

L. R. Yeager, Victor Co.'s representative for Illinois and Wisconsin, has established a temporary headquarters in Chicago and will probably remain here for the next four or five months. This is the first time in the history of the Victor Co. that one of their representatives has established headquarters in Chicago for such a length of time.

L. C. Wiswell Attends Meeting

L. C. Wiswell, manager of the Victor department of Lyon & Healy, left on Monday of this week for Philadelphia, where he went to attend a meeting.

(Continued on page 75)

THE "WADE" FIBRE NEEDLE CUTTER

assures "20 or more" *Original* New Points to each Fibre Needle

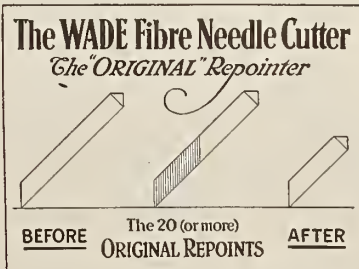

—and therefore is the most economical Fibre Needle Cutter on the market. You know the many advantages of using Fibre Needles—more natural reproduction; more tunes for one cent; no wear and tear on records, etc., etc., but, do not make the mistake of buying anything but the best Fibre Needle Cutter.

The Wade is the oldest Fibre Needle Cutter on the market—sells on demonstration—never fails to give satisfaction—is made in two styles—\$1.50 and \$2.00.

Usual trade discounts—Write for samples or Order from your regular Distributor



Fibre Needle Cutter No. 2
Price \$2.00

WADE & WADE, 3807 Lake Park Ave., Chicago, Ill.

SERVICE That Sells!

Lyon & Healy offer the Victrola dealer selling co-operation which helps to move the goods and at the same time makes yours the best advertised name in your community.



1. An exclusive newspaper advertising cut service of 52 cuts per year, \$8.33 per month.
An exclusive service, half of the above, 26 cuts per year, \$4.17 per month.



2. An exclusive art cover service which is used instead of an envelope to mail the monthly supplement. A service which cannot be duplicated. Prices on application.



3. Art Window Posters, featuring the new records. Four illustrated cards, two 14x22 inches in size, and two 14x11 inches, printed in colors, \$1.25 per month.

4. Big 24 sheet bill posters, 10x25 feet in size, lithographed in colors. *Complete with name strips.* Cheap and effective publicity.



5. "Soldier Songs," a booklet 3x6 inches. Everybody wants them, each 2c.



6. Small instruments newspaper advertising, 36 cuts per year, per month, \$4.17.



7. Piano newspaper advertising service, consisting of 48 live illustrations and copy—FREE to our dealers, write for our proposition.

LYON & HEALY

Victrola Distributors

CHICAGO

Samples of our services sent without charge

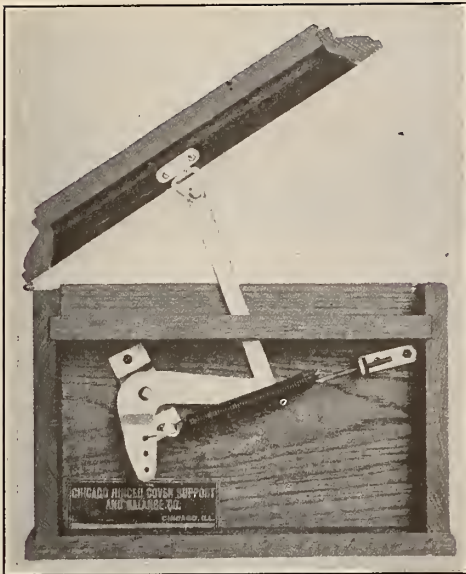

(Pat. Applied For) COVER BALANCE No. 1

ARCHIMEDES (B. C. 287? - 212)

Who discovered the working principles of the fulcrum and lever, astonished his countrymen by saying, "Give me a lever long enough and a place to stand upon, and I will lift the world."

After two thousand years we applied the Archimedes principle to

The Chicago Cover Balance Number 1

And we also astonished our countrymen by saying, "Give us a place to put it on (your talking machine) and we will lift a world of trouble off your shoulders." We have proved it time and again.

The Chicago Cover Balance No. 1 is scientifically correct in every detail and will give perfect balance to any talking machine cover regardless of weight by means of its simple adjustment.

EQUIPMENT COUNTS

The cover is "PUT" and "STAYS PUT"

WE ALSO MANUFACTURE CONTINUOUS AND EMPIRE TOP HINGES

Chicago Hinged Cover Support and Balance Co. 2242-44 W. 69th Street CHICAGO, ILLINOIS

FROM OUR CHICAGO HEADQUARTERS—(Continued from page 73)

tend the meeting of the executive board of the National Association of Talking Machine Jobbers. If business matters did not interfere, Mr. Wiswell contemplated a visit to the Victor factories at Camden.

Takes Up Training in New York

George Wiswell, who was connected with the Victor department of the West Music Co., Joliet, Ill., and brother of the well known L. C., of Lyon & Healy fame, left Chicago on Sunday, August 4, for New York, where he went to enter Columbia University to take up final training as a Y. M. C. A. secretary before leaving for the front.

Fred A. Aylesworth Visits

Fred A. Aylesworth, manager of the Vocation department of the Aeolian Company's branch at Indianapolis, is spending a few days' vacation in Chicago calling on his many friends in the trade. Mr. Aylesworth, prior to his appointment as manager of the Vocation department at Indianapolis, was manager of both the Sonora and Vocation departments of the Julius Bauer Piano Co., Chicago. Manager Aylesworth stated that he was very pleased with the business conditions now prevailing in Indianapolis and that the "Music in the Home" propaganda is broadening the field for talking machine men of the country to a great extent.

Liberty Loan Chairman

L. C. Wiswell, manager of the Victor department of Lyon & Healy, has been appointed chairman of the talking machine division of the County of Cook for the coming Liberty Loan campaign. Mr. Wiswell is at present mapping out his plans for the campaign and expects to appoint a committee of several men in the trade, each man to look after his individual company and its clientele.

W. C. Fuhri Optimistic

W. C. Fuhri, manager of the Chicago branch of the Columbia Graphophone Co., has just re-

turned to his desk after spending a few weeks' vacation in Michigan accompanied by his family. After looking over the trade situation upon resuming his duties, Mr. Fuhri became very optimistic regarding the business outlook for the coming season.

Columbia Girl Enlists

Miss Florence Bell, secretary to W. C. Fuhri, manager of the Chicago branch of the Columbia Graphophone Co., has enlisted as a stenographer in the Red Cross overseas unit which leaves for duty in France and England within a few days. Miss Bell is an exceptionally brilliant business woman and has been in the employ of the Columbia Co. for the past eight years. Her fellow employes of the company presented her with a handsome traveling bag before she left Chicago.

Another old-time employe of the Columbia Co., who left this week to take up war activities, was Scott Smith, the colored porter, who had been a Columbia employe for the past sixteen years. Mr. Smith is now employed in an ammunition factory near Chicago.

"Good Pickin's"

V. K. Tremblett, who represents the Chicago Talking Machine Co. in Indiana and Illinois, while aboard a train bound for Indianapolis recently, had the misfortune of being thoroughly "frisked" by a member of the light-fingered gentry who happened to be traveling in the same direction. Mr. Tremblett was comfortably ensconced in an upper Pullman berth, having visions of lots of orders and plenty of goods to supply the demand, numerous singing birdies, flowers and—but, when he awoke he discovered that he had been "touched" for his wallet containing \$150, Government identification card, baggage checks and other trinkets. No one aboard the train seemed to know just who the gentleman was who had such taking ways, but the railroad detectives as well as the Indian-

apolis police department have hopes of making his acquaintance at an early date.

Was a Busy Man

L. E. Noble, manager of the wholesale Victor department of the Rudolph Wurlitzer Co., is spending the remainder of his vacation in visiting his home town at Edgerton, Wis., this week. Mr. Noble was unable to spend his regular two weeks of vacation visiting his folks, owing to the shortage of help and other business reasons, and this necessitated his splitting his vacation time in two periods. He spent one week around the latter part of July vacationing and returned to his desk, awaiting a favorable opportunity when he could return and complete the "respite."

Empire Phono Parts New York Agency

C. L. Stevenson, whose headquarters are at 1133 Broadway, New York, has been appointed Eastern representative for the Empire Phono Parts Co. for New York and vicinity. Mr. Stevenson has already been successful in interesting a great number of Eastern manufacturers with the Empire tone arms, sound boxes and repair parts, and at present states that he has quite a number of new firms considering the adoption of Empire Phono Parts equipment as their standard. Mr. Stevenson is a man of much experience in the talking machine field and is well known not only to the Eastern trade but to the Central West as well. He is in a position to render valuable assistance to his clientele, owing to his vast fund of knowledge gained by long experience, and is now in a position to take care of all inquiries received from the manufacturers relative to the Empire Phono Parts products.

The Empire Phono Parts factory at Cleveland has been turning out their products in large quantities, and is at present in good position to take care of additional new business. Every

(Continued on page 77)

TRANSFER NAME-PLATES

We make the Transfer Name-Plates and Trade-Marks for the largest talking machine manufacturers in this country and for dealers in every state.

YOUR NAME, Mr. Dealer, on every machine brings the owner back to you for records and his friends to you for a machine.

Samples, Suggestions and Sketches Furnished Free

THE MEYERCORD COMPANY, CHICAGO

Largest Manufacturers of **DECALCOMANIA** Transfer Name-Plates

Telling the Public the Truth About Phonograph Values

IT is a conceded fact in the phonograph world that the coming of The Brunswick brought about a new era

both in reproduction and in selling.

Previously, the main stress had been placed on records, on exclusive artists. The record business appeared primary, the phonograph secondary.

Each make of phonograph had its own make of records.

A dealer and his customer had to make a choice, and then forego all other records.

The Brunswick Method of Reproduction created its first sensation by including an all-record player of unusual simplicity, and we called it The Ultona.

Our announcement of this advanced idea, and the subsequent advertising was on a large scale. Prospective buyers everywhere gained new standards by which to judge.

In all Brunswick Advertising we state compelling facts—and no thinking prospect can afford to ignore them. We call attention to the handicaps of the old methods, how one must be content with a limited selection of artists.

We show how The Ultona is adjustable at a turn of the hand to play any record, exactly as it should be played, with the proper diaphragm and needle.

All this creates confidence and curiosity. We have sent thousands of people to Brunswick Dealers this way.

We also spotlight another feature of The Brunswick Method of Reproduction: The Brunswick Tone Amplifier. We tell how this advanced designing in an all-wood chamber brings better tone.

Such frank arguments as these, gentlemen, are the very same arguments which thousands of Brunswick Dealers and their sales people use in their talks to customers. And so their force is doubly strong.

We intend to keep on with this successful way of helping our dealers. Forthcoming advertisements will reiterate these arguments, and we are reaching millions.

If you are interested in joining our group of money-making dealers, and if there is an opening in your town, let us hear from you. You'll be interested in our proposition

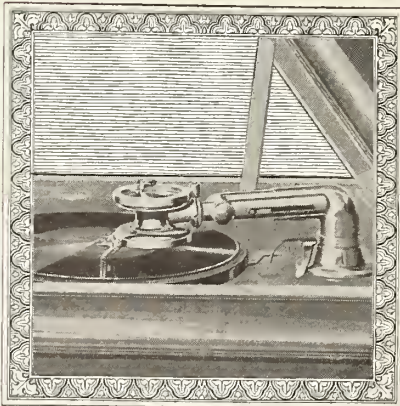

The
Brunswick
ALL PHONOGRAPHS IN ONE

THE
Brunswick-Balke-Collender Co.

General Offices: CHICAGO and NEW YORK

Branch Houses in Principal Cities of
United States, Mexico and Canada

Canadian Distributors: MUSICAL MERCHANDISE SALES CO.,
Excelsior Life Building, Toronto



FROM OUR CHICAGO HEADQUARTERS—(Continued from page 75)

department of this factory is under the personal supervision of W. J. McNamara, president of the company, and this insures not only an analytical inspection before being shipped but insures that only the highest qualities of supplies will be permitted to be shipped.

Empire Talking Machine Co. News

John A. Steinmetz, president of the Empire Talking Machine Co., has been receiving many interesting letters recently from Empire dealers, telling of their experiences in selling Empire talking machines. A letter received this week tells how one Empire dealer sold his customer.

The latter called late on Saturday night and stated that, after seeing a great number of the other machines that made their appeal by means of prices only, he was impressed by the unusual tonal qualities and workmanship as well

furnish this copy to their dealers on request.

The new Empire records, as announced elsewhere in this issue of The World, mark a new epoch in Empire achievements. These records are vertical cut and are played by either the steel or fibre needle. The composition of the material used has been perfected to such a degree that it practically eliminates the surface noise.

The company have also had designed for them a new label for these records, the label being a black background, printed in gold, and the records will be known as the Empire "Black" label. The first release contains forty numbers, embracing a wide range of subjects, such as popular and late war songs, the latter predominating. In addition some of the latest jazz band numbers and unusual selection of marimba pieces are also included in the list. The October numbers are now ready for shipment, and in connection with these records the Empire Co. have had prepared for them an exceptionally handsome wall hanger heralding the latest releases. This supplement is a very artistic example of the highest grade of printcraft, and a liberal quantity is supplied with all orders.

Open New Department

Barnhart Bros. & Spindler are rapidly completing the reorganization of their plant and from present indications expect to have their talking machine department in full operation by the fifteenth of September. This department has been equipped with entirely new machinery and arrangements have been made for a larger output of die castings which will permit of increased production. It is expected that the new plant will be able to clean up accumulated orders on hand by at least the first of October, and they will then be ready for new business.

In designing the new department the architects took into consideration the demand for the Barnhart Bros. & Spindler talking machine motor and have provided for ample space for this department to handle this part of their product.

R. N. McArthur, sales manager, stated that orders were coming in in large numbers and all the manufacturers seem to be willing to wait for a few weeks until the October delivery as they have been made aware of the reorganization of the entire plant, which makes for conservation of man power as well as space. The engineers of this company are rapidly completing the new set of multiple dies for die casting, which have a capacity six times greater than the old method and allows an additional number of castings to be made at once, where there was formerly one. The main elbow of the new cast is spherical in shape and extra weight is added to the lower end, which tends to give more balance to the tone arm and thereby eliminates any possibility of rattling. A new heavy base ring, which is practically nondestructible and makes a more substantial and

foolproof anchorage, is also a part of the new die castings being turned out.

Campaigning for War Exposition

On Thursday of last week a number of the cast of the "Oh, Look" company, which is now playing at the LaSalle Theatre in Chicago, toured the streets of the loop in a ticket-selling campaign for the benefit of the War Exposition now in progress. The members of the company who composed the party boarded a large auto truck on which was placed an upright piano and a Columbia graphophone. The tourists began at the LaSalle Theatre and made numerous stops at various of the busy loop corners and whenever a stop was made, Harry Fox, who is having such phenomenal success singing, "I'm Always Chasing Rainbows," sang in accompaniment to his record, which is just being issued by the Columbia Co. The Dolly



"Oh Look" Co. Selling War Expos. Tickets. Richard Carroll, Author at Piano—Dolly Sisters in Truck—Extreme Right, Harry Fox Dancing.

sisters helped attract the large crowds by dancing on the sidewalks. Richard Carroll, author of "Oh, Look" was kept busy a great deal of the time in supplying music for the dancing. The event proved such a success that the idea was carried out on Friday, Saturday and Sunday.

The Brunswick Dealer Service Portfolio

The Brunswick-Balke-Collender Co., manufacturers of the Brunswick phonograph, are not surpassed by any rival in the thoroughness of their preparation for assisting the retailer in carrying out successful selling campaigns. Under the direction of S. J. Turnes, their well-known advertising manager, this company has just put forth a new and entirely unique publication, which cannot fail to provide a weapon of high potency to all Brunswick retailers everywhere.

"The Brunswick Dealer Service Portfolio" is a handsome and sumptuously gotten-up collection of illustrations, specimen ads, sales arguments, descriptions and general ginger-producing matter, intended to show the Brunswick dealer in how many and how effective ways he may co-operate with the company in working up a demand for the Brunswick line.

Mr. Turnes' work in the preparation of advertisements for general dealer use is always

(Continued on page 79)



Cut of Empire Style for Use of Dealers

as materials used in the Empire and that he could see no reason why he should purchase a machine the only merits of which were counted by the cheapness of dollars and cents.

The Empire Co. have just had produced for them a number of new electrotypes, which they supply to Empire dealers for local newspaper service. The Empire Co. have been carrying out this plan of supplying new cuts to their dealers at regular intervals, and the results reported by these dealers show a very marked increase in their business. The new electros are very effective, as may be seen by the accompanying illustration, and the Empire Co. are advising their dealers to avail themselves of these cuts as soon as possible. The Empire advertising department is also getting out some very effective copy to be used in conjunction with these cuts and is also preparing at present to

UNIVERSAL TONE ARM

**NO SPRINGS
NOR WEIGHTS
TO ADJUST**

**MADE IN
FOUR
LENGTHS**

Patent Applied For

Talking machine manufacturers should anticipate their tone arm needs early to insure prompt delivery. The demand for phonographs this Fall will be very large, and it is the manufacturer who places his order early that will be given the benefit of Empire service. Get in touch with us at once and secure our quantity prices on this splendid equipment.

Address all inquiries to Chicago Office

**PLAYS ALL
MAKES
OF RECORDS
PERFECTLY**

**WRITE
US FOR
PRICES**

THE EMPIRE PHONO PARTS COMPANY

Sales Office: 425 SO. WABASH AVE., CHICAGO, ILL.
Factory: 1100-1108 W. 9th STREET, CLEVELAND, OHIO

PHONOGRAPH DEALERS ENDORSE HIAWATHA QUALITY

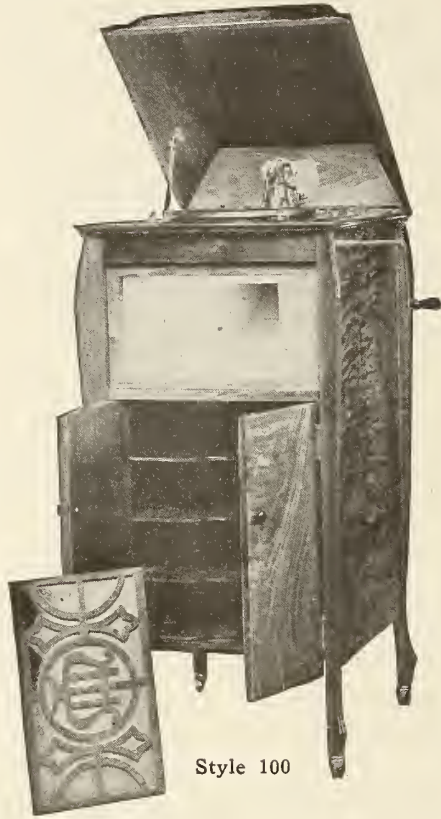

Style 100

Hiawatha Phonographs Repeat

Any phonograph you sell that will bring you repeat business is honest merchandise.

Dealers endorse the Hiawatha by their repeat business, service and satisfaction.

They can sell Hiawatha Phonographs with every confidence that they will be satisfactory in tone, finish and equipment.

FIVE HIAWATHA MODELS
\$50, \$75, \$95, \$125 and \$175

IMMEDIATE DELIVERY



Hiawatha Phonograph Company

209 South State Street
CHICAGO, ILL.

FROM OUR CHICAGO HEADQUARTERS (Continued from page 77)

clean and telling. His copy has the knack of saying something pointed always; and of saying it in a way that produces results. Among the various specimen pieces of copy offered to the Brunswick dealers in this portfolio is a series of small newspaper ads, each one featuring a single point in the Brunswick equipment or in the tonal and architectural advantages of the machine. The series is intended for successive publication at regular intervals in newspapers, and is in every sense telling and sharp-pointed.

The Brunswick machine possesses many highly interesting features, as everybody knows. Probably the one most interesting of all, to the dealer, is the remarkable Ultona sound box, which permits the use of records which take any one of the three accepted styles of reproducing stylus, diamond-point, sapphire-ball or steel needle, without detaching parts or removing needle points (save, of course, the regular Victor type steel needles, replaceable after playing one record). By means of the duplicate diaphragms the sapphire and the diamond point reproducers may remain in place permanently, each having its own proper separate socket, which is therefore always pitched at exactly the right angle. This feature of providing not a mere changeable attachment but an actual separate permanently installed reproducing equipment for each and every requirement is one of the principal Brunswick sales weapons, and naturally receives the greatest amount of attention in the very ably written advertisements built specially for the dealer and exhibited in the Dealer Service Portfolio.

At the present time, when so many talking machines of varied type, price and style are on the market, it becomes each day more necessary for dealers to become thoroughly acquainted with the exact meaning and the relative sales-promoting strength of each and every mechanical, acoustic or architectural feature of the machines they are pushing. When this education has been gained by the dealer it must be brought before the public and driven home. It is the mission of the remarkable series of advertisements contained in the Dealer Service Portfolio to put the Brunswick message across to the retailer first, and then to the consumer.

The Brunswick-Balke-Collender Co.'s advertising department has prepared and stocked matrices and cuts covering the various advertisements contained in the portfolio, in convenient sizes to suit all requirements.

Endeavoring to Supply Needs of Customers

The only complaint that has been made for some time past by W. G. Fricke, of the Lakeside Supply Co., manufacturers and jobbers of talking machine supplies, has been regarding inability to obtain sufficient stock of their various parts to supply the demands of their customers. Within the last few days, however, they have received a further shipment of one thousand of a very popular type of two-spring motor with which they have had much success, and this came in time to enable them to satisfy some specially insistent demands. The company reports being one thousand orders behind in tone arms and has been experiencing much difficulty in getting sufficiently large shipments on these items.

The questionnaire which was sent out recently by the Music Industries Chamber of Commerce, which manufacturers were invited to fill in, in order to bring out clearly before the Government the actual needs of the musical industries in the way of raw material for the winter, occupied the attention of all concerned at the Lakeside offices last week for more than a day. Mr. Fricke made a special point of turning in a model statement, hoping to give a good example to other manufacturers who have been, unfortunately, negligent.

Big Repair Part Stock

The Consolidated Talking Machine Co., 227 West Lake street, this city, who market several popular makes of talking machines of their own production, also carry in stock a very complete

line of repair parts for all makes of talking machines, new and old, current and obsolete. Mr. Fern, the genial president of the company, says that their facilities are such that if they cannot obtain a repair part for a certain machine they can make it, and make it quickly and well. The company also do repair work, and a visit to their shop convinces the caller that they are equipped for the best of service. They make a specialty of doing expert repair work for dealers.

New Wilson Manager

A. L. Spring assumed the responsible position of manager of the talking machine department of Thos. E. Wilson & Co. early last month. Mr. Spring is to be congratulated on his appointment, especially in view of the fact that Thos. E. Wilson & Co. is a direct subsidiary of Wilson & Co., the many-time-millionaire packing concern. The Thos. E. Wilson & Co. corporation devotes itself exclusively to sporting goods, gut strings and musical merchandise, such as ukuleles and talking machines. The

talking machine business has grown to very large proportions in a comparatively short time since the inception of this house.

Mr. Spring is a very experienced man. He has been for a number of years with the Aeolian Co., first on the pianos and players and for the last few years on the talking machines in the Vocalion division. He has had extensive experience both in the wholesale and retail end of this branch of the business and is therefore eminently fitted for the important position he now fills. The present Wilson line of talking machines is a very complete one and well worthy of investigation by energetic dealers.

The Fulton Alden Reproducer

The new Blood reproducer, the latest product of the Fulton Alden Co., Inc., of Waukegan, Ill., which is now being exhibited on the second floor warerooms of that company in the Athenaeum Building, Chicago, is receiving much favorable comment from members of the trade who have investigated. The new reproducer,

(Continued on page 80)

An Old Story About a

VITANOLA



8 Models
\$27.50 to \$250.00



Trade Mark Registered

LA FAYETTE, IND.

VITANOLA TALKING MACHINE Co.,
Chicago, Ill.

GENTLEMEN:—It may be an old story with you, but I want to tell you we came into competition with a \$200.00 ——— machine with a Style 100 Vitonola last Monday, in the home of one of our prominent citizens here and the Vitonola was purchased BECAUSE IT HAD A RICHER, MORE MELLOW TONE than the ——— machine.

We are frank to say we expected to lose when we found the competitor had placed such a large machine in the home alongside of ours.

The fact remains, however, that eight members of the family, all adults, agreed verbatim that the Vitonola was richer and more mellow than the competitor's gold plated product.

We are playing this up for all we can and we venture the assertion that we are going to do a big business with you.

Yours very truly, (Signed)

The Vitonola has met with this very same experience time and again.

Get in touch with us at once and get this valuable agency while there is opportunity.

It will make you some good money.

VITANOLA TALKING MACHINE CO.
501-509 W. 35th Street CHICAGO, ILL.

CONTINUOUS HINGES
 ROTOMETERS (SPEED TESTERS)
 MAIN SPRINGS FOR No. 3 AND No. 7
 MOTORS, HANDLES, 12" TURN TABLES
 GOVERNOR SPRINGS AND BALLS
 MICA DIAPHRAGMS, Best Grade, All Sizes
 PHONOGRAPH HARDWARE
 SAPPHIRE POINTS

LAKESIDE SUPPLY CO., Inc.
 202 So. Clark Street, CHICAGO, ILL. Tel. Harrison 3840

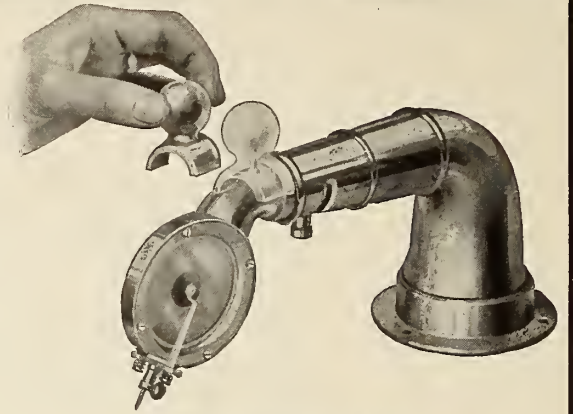

RETAIL PRICE \$7.50 EACH
 Prices to Bona Fide Dealers
 Sample\$4.00 each
 Lots of 6 to 11..... 3.75 each
 Lots of 12 to 49..... 3.50 each
 Lots of 50 to 100..... 3.25 each
 A further slight reduction on yearly contracts
 in 100 minimum lot shipments
 PATENTS APPLIED FOR

FROM OUR CHICAGO HEADQUARTERS—(Continued from page 79)

which, by the way, is the invention of B. B. Blood, is in size larger than the ordinary type, but at the same time the design is such that there is no appearance of clumsiness. The inventor lays his claims as to priority of patent rights upon the stylus bar. This part consists of a special mounting of the bar which contains a hollow space fitted with a small spring, against which plays a minute plunger held in place by a small screw. This arrangement allows for plenty of freedom and self-adjustment of the stylus bar, resulting in an unusually large range of governing tone from the high soprano voice to the deep bass. A tapered condition of the inner back plate, together with oversized diaphragm, materially helps in producing volume containing the slightest graduations of tone.

A Remarkable Instrument

Wm. Tures, head of the Combination Attachment Co., manufacturers of the well-known Oro-

tund products, has just completed a new model laboratory talking machine which has set those members of the Chicago trade who have seen it to talking as to just what the possibilities of a talking machine are. The design of the new instrument is along the lines of a high long-legged table whereon is placed the motor, tone arm, etc. The throat of the sound chamber, together with the tone amplifier, is of special design, made in such a way so as to produce an unusually large volume of tone, at the same time embracing all the modulations of the voice or musical instrument. The tone emitted is full, mellow and of a richness that is said to be truly remarkable. Mr. Tures stated that the instrument was built for demonstration purposes only and the present design is not practical for commercial purposes at present.

B. & H. Fibre Needle Service

The advertisement of the B. & H. Fibre Mfg. Co. in this issue of The World is especially in-

teresting. It outlines a campaign for the dealers and the ad itself furnishes some good ammunition for carrying on a profitable talking machine business these war days.

Hold Enjoyable Picnic

The entire advertising department of the Brunswick-Balke-Collender Co. held a fine picnic the other afternoon and evening at Lincoln Park. It was a basket picnic and there were plenty of good eats and lots of fun. Sam Turnes, who is advertising manager, said he had the time of his life with his capital young women assistants, who were very enthusiastic. Mr. Turnes has a most efficient force and is doing some excellent work for the B. B. C. phonograph and other departments.

Enter the Brownie Grand

"The talking machine with a silvery voice" is the effective slogan adopted by the Garvin-Brown Co., 2501 to 2503 North Western avenue, in a description of the Brownie grand, a very meritorious talking machine, which they are now placing on the market. The Garvin-Brown Co. have the distinction of being one of the two factories which make their own cases. Their building is a new two-story brick structure, well lighted and well equipped throughout. The first floor is devoted to the mill room and to the offices, while the second floor is given up to the varnishing, the finishing and assembling departments.

The company at the present time are concentrating on a single model. Mr. Garvin has had some seven years' experience in the talking machine trade, first as a dealer and later as a manufacturer. Mr. Brown and the president of the company, P. T. Ward, are business men of long experience. The trio constitute a fine, well-balanced team and are destined to be of much importance in this trade.

THE MOTOR TRUCK AS BUSINESS AID

Timely and Interesting Volume on This Subject
 Just Issued by the A. W. Shaw Co.

"The Motor Truck as an Aid to Business Profits" is the title of a timely, carefully compiled and interesting volume just issued by the A. W. Shaw Co., Chicago. The book, which contains 540 pages, is replete with photographs, drawings, charts, etc., and the information contained therein has been supplied by men who have had extensive and practical experience in the handling of motor truck service. The book handles in detail systems of installation, the relative efficiency of different types of trucks, costs of installation, maintenance and service, and traffic and loading information that should serve to prevent costly mistakes. S. V. Norton, the author, has been associated with the motor truck industry from its inception and has as his collaborators several men who have been and are prominent in that field. The price of the volume is \$7.50.

A Tonal Wonder

The Morenus Phonograph has won widespread recognition because of its unusual tonal quality. The novel all-wood horn which enters at the bottom (not the top) of the scientifically constructed tone chamber has proven itself astonishingly efficient in securing a most pleasing tone and a remarkably faithful reproduction of the record.

The Equipment is high grade in every respect, plays both types of records, has cover support setting top at any desired angle, original tone moderator, etc.

The Morenus cases are superb productions in every respect.

The MORENUS is in 3 STYLES

- A. OAK, - - 48 inches high. Retail price, \$110
- B. MAHOGANY, 48 " " " " 125
- C. OAK and MAHOGANY, 50 inches high,
 Retail price, - - - - - 150

*Very liberal discounts to the trade
 Send for our new descriptive catalog*



Style B

The MORENUS PIANO CO.
 342 West Huron St. CHICAGO, ILL.

FROM OUR CHICAGO HEADQUARTERS—(Continued from page 80)

TIME TO CULTIVATE TRADE OF THE FARMING ELEMENT

Agricultural Districts Offer the Real Field for Talking Machine Sales at the Present Time, Declares Arthur E. Lewis, of Salt Lake City—Bringing Music to the Farm

CHICAGO, ILL., September 10.—The Mandel Mfg. Co., makers of the Mandel talking machine, have a very aggressive and hustling representative out in Salt Lake City by the name of Arthur E. Lewis. M. B. Silverman, of the Mandel Mfg. Co., had occasion some time ago to ask Mr. Lewis to tell him something about the sales methods which the latter has so successfully carried out within his territory, and the reply is of so great interest, as well as so comprehensive and instructive, that The Talking Machine World presents it herewith in extenso. It should be mentioned that Mr. Silverman has made it his policy to seek out at all times any unusual sales methods utilized in the handling

of Mandel machines. These he values highly, and attempts to make them available to all Mandel salesmen. Mr. Lewis' letter is as follows:

"As per your request I am going to give you my opinion of the possibilities of the talking machine business and where I think the best field is, and the best way to reach it. I believe to date nine-tenths of the machines have been sold in the cities, the reason for which, in my opinion, is that the city man has been educated to it. He does not have any more money, in fact, at the present time not as much. It is only a few years ago that the automobile was owned by the city man: the farmer had not been

educated up to it; in other words, he had not been educated up to turning loose real hard-earned money for what he termed a luxury, although he had ten times the use for an automobile that the city man had for electric street cars, cabs and good bicycle roads. In any way you take it the automobile has been the greatest benefactor to the farmer. The condition was the same ten years ago, but the farmer had not been convinced of the fact. To-day I believe the majority of automobiles are owned by the country gentleman; in fact, he would not be without it.

"The phonograph, to my judgment, is identically the same proposition, only more so. Music is absolutely essential to mankind, as it brings cheer where gloom predominates, just the same as the sunbeams dispel darkness. Now then, our agencies for this inspiration naturally
(Continued on page 83)



**The Wonderful New
Empire Records Are Ready**

The October release consists of 40 splendid numbers, the selections being divided among the latest popular war songs, jazz band, instrumental and several favorite ballads. For the complete new list refer to another page in this issue.



Ten-Inch Double Face Records Retail at 85c

We pride ourselves in having produced an excellent vertical cut record which can be played with a steel needle. Each and every one of the new numbers will meet with instant favor. Dealers have an opportunity to secure a high class line of records without the necessity of investing a large amount of money in order to secure our agency.

Dealers: Write Us At Once For Our New Record Supplement and Agency Proposition

Empire
PORTABLE \$35.00

That this little machine quickly proved a big seller is shown by the fact that dealers all over the country have ordered them and the demand is becoming larger every day. If you do not handle the Empire portable as yet, write us immediately for dealers' prices and our proposition on same. Plays all makes of disc records. Weighs 17½ pounds, and when closed is 7 inches high, 14 inches wide and 15 inches deep.



Showing the Empire Portable set up ready for operation

11 Other Models Retailing from \$32.50 to \$500

EMPIRE TALKING MACHINE CO.

John H. Steinmetz, President
429 South Wabash Avenue, Chicago, Ill.

Holding Fast to the Nightingale

It is our ambition to build the *one phonograph* whose *dealers* do not change.

That ambition concentrates our thought on *quality* rather than the *sale*. We have figured that if we can build **Nightingale Phonographs** so that they stand up and stay sold, dealers surely will find it out.

If they find it out—and those who find it out do not change—sales will, of course, increase enormously in volume. The past year in particular has proved that we figured wisely, for **Nightingale Sales** have more than *doubled*. It took time to prove that the genuine *solid* wood in our cabinet, combined with the *Stephenson Precision-Made Motor, Scotford Tone Arm and Reproducer*, gives to the dealer prestige and profit, satisfaction to the user.

Two years ago, the soundness of this position we had taken could already be seen.

Now the harvest is at hand!

Dealers have discovered the truth! They are increasing in numbers steadily!

AND THEY ARE STICKING—CLOSE!!!

Write to me to-day and let me cite you facts!!!

Harry B. Wolfson
President

Nightingale Manufacturing Co.

422-26 Armour Street, CHICAGO

FROM OUR CHICAGO HEADQUARTERS—(Continued from page 81)

are from those sources that have the greatest education and talents along these lines, namely, from our great artists who have given up a lifetime to the development of this great God's gift. This we find in the city for the benefit of the city man, the city man gets this privilege, he gets all the new music through vaudeville musical sketches, operas, concerts, chautauquas and various and numerous other sources. The country man does not have these advantages: he gets a little taste of the old-time church hymn played on the church organ once a week, occasionally a melody from an ill-tuned automatic piano in the small nearby village picture show, and possibly once a year a rough imitation of Sousa's Band at the circus.

"Now then, asking ourselves how can 'Mr. Farmer' get real music? How can he get a taste of the real artists, either vocal or instrumental? Elocutionists or light enjoyable vaudeville sketches from artists in that line? The answer is, from the phonograph. He can bring through this avenue the great artists and their developments of the musical arts right into his home, where he, his wife, children and friends can enjoy them and make them and their art a part of their daily life and satisfy that natural craving that every normal man has for music.

"In my judgment, all we have to do is to get directly in touch with this fellow and convince him that the phonograph will do this very thing and not only tell them so, but put the machine right into his home and give him a real example. Put on a live vaudeville sketch for the small children, a little new popular music, one or two dance selections for the young ladies of the family and then drop in on some of the old-time melodies, with which the average farmer is familiar, and then give a selection or two of Hawaiian music, and advance to a little semi-classical operatic music, and the demonstration has been made. While you are going through this, lay aside the selections that please him the most and give him a little repetition, because music, pleasing to the ear, will always sound better the second time.

"By these means a desire to have music in the home is created. The task is then to convince him not to look on every investment from a dollars-and-cents standpoint, that there is something more in life than the silver dollar. He must be shown that music in the home is one of the things that really make life worth while, that it makes a better farmer, sheepman or cattleman out of him. It is one of the things that makes a home out of a house, brings cheer, keeps your children home, brings friends and happiness. Reference should not be made to him or his home, but you should call his attention to the practical, or rather the man with the 'Dollar God,' who has not had musical advantages and has not permitted music or any other of the better things to come into his life, excepting that which shows profit. Point out that some men would ridicule the idea of Uncle Sam sending strong, healthy men out with every regiment of soldiers with musical instruments in place of guns, thereby, in his way of thinking, risking their lives and using up some of the good Government Liberty Bond money in buying musical instruments in place of bullets and powder, and that such men do not realize that music is power, and one of the elements of good which inspires a man to do a man's work in the right direction.

"With a little of this line of reasoning you are gradually convincing your prospect that he is really justified in his own mind to turn loose the price of a cow for music in his home."

WALTER ROGERS WITH PARAMOUNT

Prominent Musical Director Will Assume Important Position in Paramount Laboratories

CHICAGO, ILL., September 7.—Walter Rogers, who for very many years was the musical director of



Walter Rogers

one of the largest Eastern talking machine companies, has been appointed to assume this position with the New York Recording Laboratories, makers of the Paramount records, with recording laboratories in New York, general offices at Pt. Washington, Wis., and pressing plant at Grafton, Wis. The Paramount company have gained a great deal of prestige on account of the excellent records they are producing, although they have only been in this field a comparatively short time. They are backed by the enormous capital which is behind the great Wisconsin Chair Co., of Port Washington. They are going about the manufacturing and marketing of Paramount records in a big, broad manner. Their acquisition of Mr. Rogers furnishes new evidence of this fact,

The "Brownie Grand"

"The Talking Machine with a Silvery Voice"



Retail Price, \$150.00

Specifications

Unusually large, massive and handsome Cabinet made from the finest selected foreign and domestic hardwoods; size, 50 inches high, 23 inches wide and 24 inches deep; finished in a genuine piano polish, mahogany only. Has finest double spring motor; universal tone arm; playing perfectly any disc record made. Equipped with the latest style tone amplifier and modifier. Special resonant sound chamber scientifically constructed on acoustic principles. Unusually large record filing space.

Unusually liberal discounts to dealers, thereby insuring unusually good profits.

Write us for full particulars—also about our exclusive agency in your territory.

Jobbers Attention

We make special machines under your own name, on contracts of sufficient size, when desired.

GARVIN-BROWN CO.
2501-2503 N. Western Avenue
CHICAGO, ILL.

The OROTUND and SUPERIOR

Attachments, Tone Arms and Velvet Running Jewel Points Are Strictly High Grade

There is only one attachment on the market that will do exactly as represented, viz.: play all makes of records safely and with perfect tone on machines which are not made to play all makes of records and that is the Orotund and Superior complete attachment.

When we make the above statement we have said something, because most other attachments are too heavy, or the position on the record is not correct, which means destruction to a record.

You must hear the Orotund and Superior attachment play a few of the high-grade Edison, Columbia, Victor or Pathé records to appreciate that which we are trying to tell you.

Play your favorite record on your machine, regardless of the make, and play it musically, not with all that surface, mechanical, nasal tone.

You have missed a rare musical treat if you have not heard some of the records of all makes which we could name, played with the Orotund and Superior outfits.

Write for prices and descriptive circulars.

COMBINATION ATTACHMENT CO.
20 Jackson Boulevard, East, Chicago, Ill.

FROM OUR CHICAGO HEADQUARTERS—(Continued from page 83)

A MAN OF EXPERIENCE AND ABILITY

Is Ernest C. Cook, Secretary and General Manager of the World Phonograph Co.

CHICAGO, ILL., September 9.—As announced in last month's World, Ernest C. Cook is now secretary and general manager of the World Phonograph Co., of this city. Mr. Cook is a man of long selling experience, the result of which is shown in the number of big houses he has landed



Ernest C. Cook

as distributors for World phonographs. These concerns range in capital from \$500,000 to several millions. Houses of this character naturally would not take up the World phonograph unless they thought it worthy of their steel. The company has just issued a new catalog showing designs of very beautiful new cabinet phonographs.

AN UNUSUAL BOOK

New History and Treatise on the Talking Machine Issued by the Western News Co.

CHICAGO, ILL., September 9.—The Western News Co., of Chicago, experts of good literature of every kind, have issued a remarkable book regarding the talking machine. It gives the history from the gestative period to the present time, traces its development through all its evo-

lutionary stages and makes a legitimate prophecy as to the future. It is written by an acoustic expert, and not only an acoustic expert, but one skilled in the practical application of acoustical principles to the talking machine industry. This really remarkable brochure is of genuine interest to the dealer and to the public with which the dealer comes in contact. That the book contains, in addition to its general acoustical and phonographic information, illustrated descriptive matter of the new aspirant for phonograph honors, the Tel-O-Tone, does not in the least detract from its value.

Another rather startling thing about it is that it is free. The Western News Co. advises everyone legitimately connected with the talking machine industry to write for a copy.

ATTRACTIVE STRADIVARA POSTER

Compton-Price Co. Issues Three-Color Display Advertisement for Window Use or Bill Posting—Catalog Another Aid to Dealers—Other Advertising Aids Coming Out Soon

The Compton-Price Co., of Coshocton, Ohio, in exploiting the Stradivara talking machine, has published a very attractive poster which may be used for either window display or bill posting purposes. The poster shows one of the popular models of the Stradivara attractively displayed, the printing being in three colors; the background in blue and the machine and outlines in buff. The Stradivara note border, a distinctive characteristic of the Stradivara advertising, is also used in this design, while the text states "The Subtle Beauties of All Records Are Brought to Life Only When Played on the Stradivara." A reduced reproduction of this poster appears in The World this month. The size of the original for window display and other purposes is seventeen inches by twenty-three inches. The contrast of colors is of that nature to attract the immediate attention of the passerby and the poster constitutes one of the forceful advertising aids to dealers which the Compton-Price Co. is now perfecting.

The new Stradivara catalog is also another piece of publicity which may be used to good advantage by Stradivara dealers. It has been prepared with great care and each style of the machine is clearly reproduced, while the details of construction as well as the various individual features incorporated in the machines are simply but clearly explained in the text. The cover

Equip Your Phonographs With Perfect Automatic Brakes

Samples \$1.00 Each
Cash with order

State make of tone arm used



Also made with long brake shoe for 1 inch offset

Patented Aug. 28, '17

Simple construction and easily attached. Made in four styles to fit any make of tone arm.

Write for attractive quantity price

PERFECT AUTOMATIC BRAKE CO.
Room 400, 425 S. Wabash Ave., Chicago

shows the Stradivara name in its usual style in gold-embossed lettering under which is the slogan "Known for Tone." The volume is in truth a gem of art.

The company is working on other advertising aids for the dealer which will be announced within the near future.

The Rudolph Wurlitzer Co., of Chicago, on September 3 discontinued the practice of sending out talking machine records on approval, explaining as one of the reasons for the action the fact that the delivery of the records utilized the services of men who could be engaged in more essential work, and likewise proved very expensive.

"Does It Play All Records?"

Certainly MAGNOLA does; and without any extra attachments, too. This is only one feature, albeit a most important one, in the thoroughly up-to-date equipment of the MARVELOUS MAGNOLA.

MAGNOLA "Built by Tone Specialists"



Watching the Music Come Out

May we send you our handsome illustrated catalog chock full of information concerning the wonderful construction system of Magnola and the beauties of its musical results, its artistic appearance and its moderate price?

Send your name and let us tell you more!

MAGNOLA TALKING MACHINE COMPANY
OTTO SCHULZ, President

General Offices 711 MILWAUKEE AVENUE CHICAGO
Southern Wholesale Branch 1530 CANOLER BLDG. ATLANTA, GA.

NEW and OLD

Repair parts for EVERY make of machine—
EVERY make of motor—new or obsolete.

We are the only concern in the United States
that specializes on this line of work.

If we haven't the repair part in stock, we will
make it QUICK—and good.

We do expert repair work for the trade.

INCORPORATED UNDER THE
LAWS OF ILLINOIS

Consolidated
Talking Machine Co.
Manufacturers of

SUCCESSORS TO:
Standard Talking Machine Co.
United Talking Machine Co.
Harmony Talking Machine Co.
O'Neill-James Co.
Aretino Co.

High Grade Talking Machines, Disc Records,
Talking Machine Supplies, Etc.

227 W. Lake Street, CHICAGO, ILL.



TRADE MARK
"CONSOLA"

CABLE ADDRESS
"CONSOLA"

We Make Stamped Steel
SOUND-BOXES

in View of Shortage in Die-
Casting Market

Chicago Recording Scale Co.
WAUKEGAN ILLINOIS

CANADIAN EDISON DEALERS MEET

Large Attendance at Third Annual Convention in Toronto This Month Where a Number of Special Features Were Presented

TORONTO, CAN., September 7.—Edison dealers from all sections of Canada were drawn to the King Edward Hotel here on Thursday and Friday of this week to attend the third annual convention of the Canadian Edison phonograph dealers. The convention was under the immediate auspices of the R. S. Williams & Sons Co., Ltd., Canadian Edison jobbers, and the company was most enthusiastic over the response of the dealers to the convention call, particularly in view of existing national and trade conditions.

A most interesting program had been prepared and was carried out to the letter. After the visiting dealers had been welcomed on Thursday morning, W. A. McIntyre, of St. Mary's, Ont., read his chairman's address, after which T. J. Leonard, general sales-manager of Thomas A. Edison, Inc., delivered the greetings from the Edison Co. Particular interest was displayed in the demonstration of the new Velvet Surface Re-Creation, the latest Edison product which aroused so much enthusiasm among the dealers at the recent general convention in New York.

Among those who read papers were: Glenn B. Petch, whose subject was "Improvement in Supply and Distribution of Re-Creations"; J. D. Ford, "The New Prices and Their Effects"; H. G. Stanton, of R. S. Williams & Sons Co., "Music and the War"; Gordon H. Gray, of the same company, "Mechanical Inspection"; James H. Imrie, advertising department of Williams & Sons Co. on "Advertising"; T. J. Leonard, Thomas A. Edison, Inc., "Records and Record Production"; D. S. Cullen, Kitchener, Ont., "An Attractive Store as an Asset to Your Business"; S. C. Thornton, Dundas, Ont., "How I Get Prospects"; Miss Laura Scribner, Thomas A. Edison, Inc., "Tone Tests," and a number of others. Practically all the papers had direct reference to selling and advertising problems of Edison dealers, and were, therefore, most pertinent and helpful, a particularly interesting paper being that on "Finance," by Harrison Durant, of the Commercial Trust and Investment Co., New York. John A. Fullerton, of Toronto, secretary of the "Music In the Home" propaganda, was asked to explain and outline what progress had been made in the campaign, which he did in his usual able manner.

On Friday there was a cornet tone test by E. E. Farringer, a motion picture theatre novelty violin act by Percy Sky, of Toronto, and the presentation of William Maxwell's latest sales comedy, "The Dotted Line," which proved the feature at the New York convention earlier this year.

Philip E. Layton, of Layton Bros., played the accompaniment for Mr. McKay, one of the Williams road men, who played Mr. Layton's latest composition, "Soon You'll Be Coming Home, Lad," which made quite a hit.

The balance of the sessions were given over to general discussions between the dealers on general business matters.

Have you bought a Thrift Stamp to-day?

Cabinets—Cabinets—Cabinets

For dealers, wholesalers and jobbers or those who desire to sell their own brand, style and make of talking machines. Let us figure on what you desire. We are not too busy to build your cabinets.

Chas. Passow & Sons
2121 to 2141 ALLPORT STREET CHICAGO, ILL.

GENERAL MANAGER OF LYRAPHONE

Maurice C. Rumsey Appointed to Important New Post With LyrAPHONE Co. of America

Maurice C. Rumsey, formerly assistant general manager of the LyrAPHONE Co. of America, has been appointed general manager of the concern. The LyrAPHONE Co. have commenced a big fall campaign featuring the records in the fall catalog as well as those from the standard lists. This includes advertising, new colored cut-out holders for the monthly lists and monthly supplements with the imprints of the dealer and jobber. J. M. Kohner, sales manager of the company, is now making a Western trip, visiting the trade in all the larger centers of the Middle West and Pacific Coast. He reports the fall sales to be very large and that the LyrAPHONE Co. expect to have one of the biggest seasons in their history. One of the records from the standard list which the company is now making popular is the "William Tell" overture, complete on a double-faced record. This record has been created with great care and the LyrAPHONE laboratories are very proud of its production.

HOFFAY DISTRIBUTOR IN UTAH

George A. Lowe, of Ogden, to Feature Hoffay Products in That Territory in Big Way

The Hoffay Talking Machine Co., Inc., have appointed the Geo. A. Lowe Co., of Ogden, Utah, distributor of the Hoffay products in that territory. The Geo. A. Lowe Co. is one of the biggest firms in the State of Utah and is well known throughout the West. Large shipments of both Hoffay talking machines as well as "Resurrectones," the patented sound box produced by the Hoffay Co., have been forwarded to their new agents. A special campaign will immediately be put forth in the local papers of Ogden and adjacent territory and the Hoffay products are to be featured in a series of advertisements over a period of many weeks. Much of this publicity will be given through the Ogden Examiner, one of the largest papers in that part of the country. Joseph Hoffay, president of the Hoffay Talking Machine Co., Inc., is well pleased with the acquisition of the Lowe Co. to the growing list of his company's agents.

IMPORTANT CORTINA MOVE

Four New Courses to Instruct Italians, Slovaks, Poles and Hebrews in English

The Cortina Academy, 12 East Forty-sixth street, New York, whose method of language instruction through sets of phonograph records is being successfully marketed by many talking machine dealers, is planning to issue shortly four new courses.

These new courses will follow the popular plan to Americanize the foreigner within our gates and will enable him to more easily break away from his mother tongue and to use the language of his adopted country. The various courses will instruct Italians, Slovaks, Poles and the Yiddish-speaking race how to speak the English language.

Reproducers

Mr. Manufacturer:

We are prepared to furnish a limited number of reproducers for immediate delivery.

Write us what tone arm you use and we shall be pleased to submit a sample ready for attaching: if, after trial, you do not pronounce our reproducer **THE VERY BEST IN QUALITY AND VOLUME YOU EVER LISTENED TO**, we ask you to return the sample at our expense, and we thank you for the granting of this hearing.

Yours very truly,
FULTON-ALDEN CO.
Waukegan, Ill.

P. S.—Ready in 30 days: our new balanced cover-lift. Will not warp cover. Easiest to attach.

Ask for sample

FULTON-ALDEN CO
INC.
WAUKEGAN, ILLINOIS

AEOLIAN-VOCALION IN CANADA

Dealers Visiting Toronto Exhibition Entertained by the Nordheimer Piano & Music Co.

TORONTO, CAN., September 9.—Assuming that many Aeolian-Vocalion dealers would be visiting the Toronto Exhibition, the Nordheimer Piano & Music Co., Ltd., Canadian representatives, tendered an informal luncheon at the National Club to all dealers and which was taken advantage of by all who were in the city at the time. The guests were received by E. C. Scythes, general manager, and Thos. C. Wright, wholesale manager of the Aeolian-Vocalion department.

The gathering was looking forward to a visit from W. H. Alfring, general manager of the Vocalion division of the Aeolian Co., but unfortunately owing to business reasons he was unable to be present. A. C. Barg, of the Vocalion wholesale department, New York, who was on hand, was immensely pleased with the enthusiasm and spirit shown by Canadian dealers. During the luncheon the guests were treated to new Vocalion records played on the Aeolian-Vocalion and listened to by all with unusual interest.

THE WISDOM OF BENNIE

"My boy Bennie is lazy, but I must say he is smart," said the musician.

"Is he going to follow in your footsteps?"

"No, I learned to play the trombone and I've got to march about eight miles every time there is a parade. Bennie is learning the harp so they will have to let him sit down."

NEW PERIOD MODEL OF NEW EDISON

Eighteenth Century English Model Just Announced Is Genuine Work of Art

A new art model of the New Edison phonograph has been announced by Thomas A. Edison, Inc. It is known as the Eighteenth Century English Model, is designated as C-450, and lists at \$450. The finish of the instrument in every particular is most artistic, and the beauty of its design cannot be shown in a black and white cut. The Wedgwood decorations are the work of capable artists in the Edison laboratories, and are distinctly rich in their effect. The new C-450 has two compartments, the one at the right containing the mechanism, and that at the left being fitted with a filing device with a capacity for sixty-eight Re-Creations. The motor is the official laboratory model—the C-250 type.

Dealers who have seen this new Edison period style are enthusiastic over its sales possibilities and expect to book large orders for it during this fall and the coming winter.

COMBINES BUSINESS WITH PLEASURE

B. R. Forster, president, and H. W. Acton, secretary of the Brilliantone Steel Needle Co., combined business with pleasure in a motor trip taken through New England. The route lay through some of the prettiest parts of Massa-



Eighteenth Century English Model New Edison

chusetts and New Hampshire and the country seemed at its best. Many calls were made en route and a large volume of orders were accumulated. B. R. Forster has closed his summer home at Atlantic City.

Operaphone Records

Ten Inch

Retail 75 cents

The popular standard American catalog dealers have been waiting for.

We know you must have records.

Operaphone Records follow the line of least resistance, they play with steel needle on all universal tone arm machines with sound box facing front.

Order direct from Long Island City or from your machine jobber.

Send for our trial package assortment including window display and regulation catalog book.

Operaphone Co., Inc.
LONG ISLAND CITY, NEW YORK

NEW LANGUAGE PHONE AGENTS

Many Dealers Now Featuring the Language Phone Method in Energetic Manner

P. J. Doherty, sales manager of the Language Phone Method, the makers of disc language records, states his firm is constantly adding well-



Language Phone Display Card

known dealers to the list of agents for their products. During the fall some of the leading houses are giving window displays featuring the language courses put out by the company. Many of these displays have recently been placed in stores in well-located parts of the city and have attracted much attention. In most of the displays a large cut-out figure, in many colors, a reproduction of the company's trade-mark, has been shown. This trade-mark has recently been changed to represent an officer of the United States Army, who is presumably studying the "French Military Course" now being featured by the company especially for our forces about to go overseas. It has a great attention-getting force.

W. H. ALFRING'S NEW POST

Appointed Manager of All the Aeolian Co.'s Domestic Wholesale Departments

The Aeolian Co. announced this week the appointment of W. H. Alfring as manager of all the company's domestic wholesale departments. Mr. Alfring has been manager of the wholesale Vocalion department for the past two years, and in his new position will be in charge of all the company's domestic wholesale activities, including Pianolas, Duo-Art Pianolas, pianos, music rolls, etc.

W. H. Alfring has been associated with the Aeolian Co. for many years, having occupied several important posts prior to his appointment as manager of the wholesale Vocalion division. He has been in charge of the Aeolian branches at Indianapolis and St. Louis, and is generally recognized throughout the country as one of the best-posted piano and talking machine men in the trade. He is admired and esteemed by the dealers and his co-workers, and friends and from coast to coast have congratulated him upon his well-deserved promotion to the important position that he now occupies.

As manager of the wholesale Aeolian-Vocalion department Mr. Alfring has been an important factor in the splendid success achieved by the Aeolian-Vocalion phonograph. He has organized a capable and efficient sales staff, and has left nothing undone to co-operate with the dealers throughout the country in profitably merchandising the Aeolian-Vocalion. He has worked indefatigably to further the interests of Vocalion representatives, and in his new post will have an opportunity to co-operate with Pianola dealers along the same intensive lines.

MEIKLEJOHN CO. OPENING

New Phonograph Department One of the Handsomest—W. W. Longfellow Is Manager

PROVIDENCE, R. I., September 5.—The Meiklejohn Co., of this city, will have a formal opening of their new phonograph department some time this month. This department, which is under the management of W. W. Longfellow, formerly of the Pardee-Ellenberger store in New Haven, Conn., is very handsomely arranged with special display rooms for Edison and Starr machines. There are attractive demonstration booths and the entire furnishings are conducive to interest and hold visitors. Mr. Longfellow will have a capable staff in his department with Allen D. Waite as outside representative. Special window displays will be a feature of the opening, and nothing will be left undone to let the people of Providence know that a live up-to-date store is in "their midst."

TALKING MACHINE EXPORTS GROW

Exports, Including Records, for Twelve Months Ending June 30, Totaled \$4,684,329

WASHINGTON, D. C., September 10.—In the summary of exports and imports of the commerce of the United States for the month of June, 1918 (the latest period for which it has been compiled), which has just been issued, the following figures on talking machines and records appear:

The dutiable imports of talking machines and parts during June, 1918, amounted in value to \$45,028, as compared with \$49,669 worth, which were imported during the same month of 1917. The twelve months' total ending June, 1918, showed importations valued at \$355,785, as com-

pared with \$485,417 worth of talking machines and parts imported during the same period of 1917.

Talking machines to the number of 2,978, valued at \$104,249, were exported in June, 1918, as compared with 9,448 talking machines, valued at \$190,850, sent abroad in the same period of 1917. The twelve months' total showed that we exported 91,297 talking machines, valued at \$2,610,866, as against 78,669 talking machines, valued at \$1,987,878, in 1917, and 42,261 talking machines, valued at \$1,198,647, in 1916. The total exports of records and supplies for June, 1918, were valued at \$216,584, as compared with \$210,461 in June, 1917. For the twelve months ending June, 1918, records and accessories were exported, valued at \$2,073,463, as compared with \$1,660,439 in 1917, and \$939,790 in 1916.

The Time for the Holidays is Now!

Last season carload orders for Converto Cabinets that came late had to be turned down. Dealers who ordered a stock *early* got the cabinets and *sold them at a good profit before Christmas*. Orders for Holiday business should be placed *now!*



Patented December 11, 1917

TALKING MACHINE CABINET

This is a clearly demonstrated success. Every single Victor dealer will make money with it; in these days he can't afford not to handle it. It is our sincere advice, first to decide to try it, second to order *early*. Write or wire for prices and particulars.

**The C. J. Lundstrom Mfg. Co., Little Falls, N. Y.
Branch Office, Flatiron Bldg., New York City**

NOTICE: Lundstrom Converto Cabinets are broadly covered by patents. Infringement will be promptly prosecuted.

The Lundstrom "Converto" Cabinet converts the small "Victrola" into a handsome cabinet type, completely enclosing the machine. It takes the place of a stand and provides a dustproof record rack for 60 records. It re-creates interest in records. It helps you meet low-price competition in cabinet machines and gives you a *good profit*. It costs the customer no more than a good stand!



Setting Victrola into Cabinet

Sound Doors Open for Playing

DEALERS

Make Big Money

On Our Language Records



**French
Spanish
Italian**

ALSO

**F.M.C FRENCH
MILITARY
CONVERSATION**

Cash in *now* on the

**Language Phone Method
and Rosenthal's Practical Linguistry**

It requires no scientific salesmanship to sell our records. The courses are so simply arranged that the demonstration satisfies the prospect. The French Military Course, 5 Double Discs, and Military Manual (Retail \$10.00) is ideal for Army, Navy, Red Cross

Excellent Line for Dealers Near War Camps
Send for Particulars

THE LANGUAGE PHONE METHOD

992 Putnam • 2 West 45th Street, • New York

FOR YOUR OWN SAKE as well as FOR OURS

Get Acquainted With

The
BUSH & LANE
 Phonograph

"Built by men who have made a life study of tone production"

The Case Designs

are worthy products of the artistic originality which has marked BUSH & LANE work at all times.

The Tone Modifier

is an original and *efficient* means for controlling tone volume.

The Motor

is extra well built and extra long-running.

The Workmanship

is as nearly perfect as such work can be.

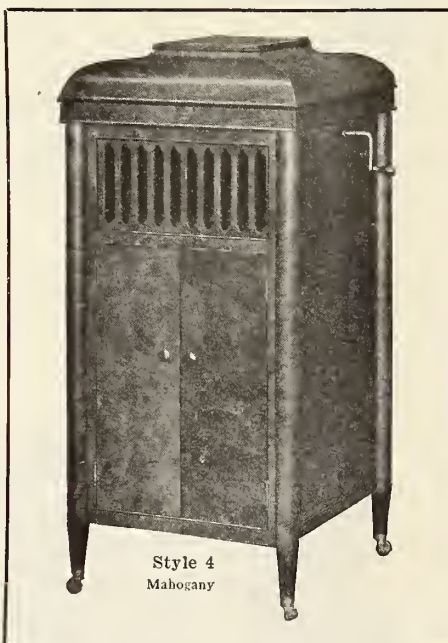

Style 4
Mahogany

The Principle of the Piano Sound-board

has been utilized in the construction of the marvelous BUSH & LANE **Tone Chamber**, which neither cracks, nor swells, which is designed on *correct* acoustic principles, and which is one of the **great features** of a great machine.

The Tone-Arm

is delicately balanced and rightly shaped.

The Reproducer

plays all makes of records, without special attachments.

Send for our handsome illustrated catalog. It describes the goods and gives a topping sales argument besides

BUSH & LANE PIANO COMPANY

HOLLAND, MICHIGAN

Get out after those Vacation Models you sold last Summer. Every one should be traded in for a New Model Grafonola with the Non-Set Stop.

Columbia Graphophone Co.
NEW YORK



REPAIRS

TALKING MACHINE TROUBLES AND HOW TO REMEDY THEM

Conducted by Andrew H. Dodin

[This department of The Talking Machine World is designed for the service of all classes of our readers, including those who make, and those who sell, talking machines. Andrew H. Dodin, who conducts this department, has a wide and enviable reputation as a repairer of talking machines and conducts an exclusive talking machine repair shop at 176 Sixth avenue, New York. Tell him your troubles through The World and he will help you if possible. The service is free.—Editor.]

SOME QUERIES AND ANSWERS

Adjustment of the Mica

Sheboygan, Wis., August 27.

Editor, Talking Machine World: Can you advise us as to the relation or the effect the distance of the mica from the back of the sound box has on the sound which the same produces? If there is any marked difference, will you kindly refer us to some book or table showing what distances the various sizes of mica should be from the back of the sound box?—U. P. C.

ANSWER—Do not know of any book or table giving this information. The distance of the mica from back of sound box should be determined by experiments. The size of the hole in the back through which the sound passes, the width and thickness of the mica and the method of tensioning the needle bar are all factors to be considered.

In "The Phonograph Book," by Lloyd Macfarlane, page 83, is the following: "The distance between the inner side of the metal casing or cup and the inner side of the diaphragm is of the utmost importance, as it is in the construction of a recording sound box. About one-sixteenth of an inch is the usual practice, although the distance between the mica and metal face of the cup varies according to the size of the sound box, the record it is adapted to be played with and other considerations, so that there is no particular rule governing the so-called 'air space.'"

A Polishing Formula

Somerville, Mass., August 26.

The Talking Machine World: Kindly send formula for a first-class all-around polish for piano and phonograph cases, with such suggestions as you may have to offer for its use. There are numberless preparations on the market, also formulas, very few of which are worth while. I want something which will do the work well and quickly, as I handle quite a few tradens and it is not always profitable to spend a great deal of time on them.—G. H. D.

ANSWER—The polish preparations on the market to-day are all of about the same formula with an added coloring matter or perfume to make them appear different from one another. Crude oil as the base, with benzine, rottenstone and lemon oil in varying proportions, a coloring matter and a perfume is a sample combination. However, these preparations only wash the dirt

off and put a temporary polish on the varnished surface. The only reliable method of cleaning and polishing the cabinet is by the usual hand-rub with pumice-oil, rottenstone, etc.

Cause of Noisy Motors

Somerville, Mass., August 26.

Talking Machine World: What is the most common cause of a noisy phonograph motor? I understand, of course, that an old worn motor would naturally be noisy, but I find this trouble in motors which have been in use a year or two. Any information you can give me on these matters will be greatly appreciated.—G. H. D.

ANSWER—The most common cause of noisy motors is the lack of graphite on the springs. The

main springs should be taken out of the cages, cleaned with gasoline, replaced, and fine flake graphite mixed with heavy oil to the consistency of molasses placed in the leaves of the springs, using about two tablespoonfuls to each spring. A worn governor drive gear and governor spindle is another cause for noise in a motor used for a year or so.

The Stephenson Motor

New Britain, Conn., August 26.

The Talking Machine World: Can you inform me where I can obtain one Stephenson motor?—J. A. L.

ANSWER—Stephenson, Inc., 1 West Thirty-fourth street, New York.

RECORD RECRUITING CORPS FORMED

People Prominent in Musical World Back of Movement to Collect Machines and Records for Distribution to Units in Service

The National Phonograph-Records Recruiting Corps has been organized in New York for the purpose of collecting talking machines and records for the men in service, and to see that they are distributed among the various camps, cantonments and ships. Major-General J. Franklin Bell, Commander of the Department of the East, is honorary president of the corps, and Vivian Burnett is chairman of the national committee, the membership of which consists of men and women of much prominence in the musical world, including Enrico Caruso, Frank Dam-

rosch, Mrs. Carrie Jacobs-Bond, Daniel Frohman, Mme. Galli-Curci, Victor Herbert, John McCormack, Lieut. John Philip Sousa and others. The corps is arranging for a recruiting week for records from October 26 to November 2.

On the back covers of the September magazines appears a most striking advertisement of the Victor Talking Machine Co. emphasizing in no uncertain manner the part played by the Victrola in cheering the lives of our fighting men on the high seas. The caption of the advertisement is "Carrying the Song of Victory Across the Seas," and the attention-commanding illustration shows a battleship in action. An insert offers a view of a group of naval officers enjoying a Victrola concert in the wardroom.

IMMEDIATE DELIVERIES

Specials

FOR

Victrola IX

WE have in stock other cabinets to fit all styles of machines and will be glad to send our catalog for the asking.

Schloss Bros.

635-37 West 55th St.
NEW YORK

Phone
Columbus 7947



809

Mahogany, Golden Oak, Fumed Oak, Weathered Oak, Nickel-plated trimmings. Lock and key. Height, 33 inches. Top, 22 3/4 x 19 1/4 inches. Holds 192 twelve-inch records. Matches new Victrola IX. Highest type of cabinet, both in construction and finish. Average weight crated, 80 lbs.



702

Mahogany, Golden Oak, Fumed Oak, Weathered Oak, Nickel-plated trimmings. Lock and key. Rubber-tired wheels. Height, 30 inches. Top, 17 x 20 1/2. Matches New Victrola IX. Top has countersunk holes to accommodate rubber bumpers on machine. Moulding on top securely fits base of machine. Average weight, crated, 75 lbs.

Our Bigger Partnership

IT MATTERS little, today, what our individual business is, yours and mine. That business may seem to us, as individuals, to be most important, but its true worth is determined by its relation to the greatest business of all—the *business of winning this war.*

We are proud of the fact that, in this great business, we are active partners with Uncle Sam *active*, because in yonder room, where yesterday skilled craftsmen were working on Stephenson Precision-made motors, today only munition parts are made.

And this influence makes itself felt in many ways on our product in reduced production, in increased difficulty in obtaining raw materials in many ways.

But we are partners, active partners, with Uncle Sam. And we are proud, and content to slack our own business until our bigger partnership is dissolved until all is over, over there.

Cordially yours,



Vice-President

STEPHENSON, INC., One West 34th Street, New York

Manufacturers of the Stephenson Precision-Made Motor

PLANNING BIG TRADE DRIVE FOR FOURTH LIBERTY LOAN

J. Newcomb Blackman, Chairman of Talking Machine Division of Allied Music Committee, With H. L. Willson, Roy J. Keith, E. N. Boykin and C. G. Child as Sub-Chairmen

The local talking machine trade is preparing to participate actively with the other branches of the allied music trades in putting the coming Fourth Liberty Loan "over the top" in a manner to surpass all previous records along this line. It will be remembered that members of the talking machine trade during the Third Loan drive rounded up subscriptions that came close to eclipsing those of any other branch of the industry, tying the piano men, through courtesy, it is said, for first place. The drive on the Fourth Liberty Loan begins on September 28.

Benjamin Strong, director of the Federal Reserve Bank, has appointed Mark P. Campbell, president of the Brambach Piano Co., chairman of the Allied Music Committee, Industrial and Professional, with J. Newcomb Blackman, president of the Blackman Talking Machine Co., as vice-chairman; Charles Jacob, of Jacob Bros.

Co., treasurer, and Albert Behning, secretary. The headquarters of the committee will be at 105 West Fortieth street, New York.

Mr. Blackman, in addition to being vice-chairman of the general committee, will also be in direct charge of the campaign in the talking machine trade, a tribute to his efforts during the last drive. Under his direction will be sub-chairmen to take care of each division of the trade, and under them in turn will be captains and lieutenants to solicit subscriptions. The entire trade has been carefully card-indexed in order to make the work most systematic and effective.

In the talking machine trade the sub-chairmen will be H. L. Willson, general manager of the Columbia Graphophone Co., in charge of the manufacturers' division; E. N. Boykin, Thomas A. Edison, Inc., sub-chairman in charge of the

talking machine dealers' division; C. G. Child, Victor Talking Machine Co., in charge of the talking machine musical artists' division, and Roy J. Keith, of the New York Talking Machine Co., in charge of the wholesalers' division. The appointments of captains in the different divisions are now being made, and the organization arrangements will be completed at a meeting of the general committee to be held shortly. It is very probable that some sort of rally similar to the wonderfully successful affair held in Carnegie Hall during the last drive will be staged in connection with the work on the Fourth Loan, but nothing definite along this line has yet been announced.

The subscriptions of the talking machine interests will go in with those of piano manufacturers, merchants, musical merchandise houses, music roll manufacturers, music publishers and the professional music interests, including teachers, band and orchestra men, etc.

IMPORTANT COLUMBIA CHANGES

Dictaphone Sales Division Placed Under the Direction of General Sales Manager Geo. W. Hopkins, Who Announces a Number of Important Appointments—Gifts for Milnor

H. L. Willson, general manager of the Columbia Graphophone Co., of New York, announced this week that beginning September 1 the activities of the Dictaphone sales division are placed under the direction and supervision of General Sales Manager Geo. W. Hopkins.

Mr. Hopkins has announced the appointment of N. F. Milnor, formerly sales manager of the Dictaphone division, as manager of the Columbia Co.'s San Francisco branch. Mr. Milnor is now en route to the Coast. C. K. Woodbridge, formerly connected with the Kellogg Food Products Co., Buffalo, N. Y., has been appointed Dictaphone sales manager. Mr. Woodbridge will assume his new duties September 16. F. A. Denison, formerly manager at San Francisco, is expected at the executive offices in New York very shortly, when he will be assigned to a managerial position which will be announced at that time.

Before leaving for the Coast Mr. Milnor was presented with a handsome solid gold watch by the New York Sales Managers' Club, of which he was one of the founders. His former associates in the Columbia Co. gave him a beautiful brass desk set, and some of his intimate friends in the Columbia executive offices presented him with a solid gold chain. Mr. Milnor was one of the most popular members of the Columbia Co.'s forces, and he leaves for the Coast with the good wishes of every one of his former associates and his many friends in the trade.

EDISON TONE TESTS IN ST. LOUIS

Vernon Dalhart Gives First of Series in Silverstone Music Co.'s Studios and His Performance Arouses Much Enthusiasm

ST. LOUIS, Mo., September 10.—Vernon Dalhart, the well-known artist, began a tone test in this Edison trade district at the studios of the Silverstone Music Co., Edison jobbers, on last Saturday night, and his performance proved a distinct success, winning high praise from various newspaper representatives, as well as from members of the audience in general. In telling the story of the tone test the St. Louis Republic said in part: "Only by watching the lips of Dalhart could one be sure when he sang and when he did not. There was a slight difference in volume when he stopped singing, but was not noticeable, for the voice which came from the cabinet was round and sweet with all the vibrant, pulsating quality of that which came directly from Dalhart's throat."

Several other tone tests will be given in the St. Louis district by Mr. Dalhart in the near future.

Talking machine men get in line for the Fourth Liberty drive—everyone together.

Western Made for Western Trade

**THE
HAWTHORNE
Phonograph**

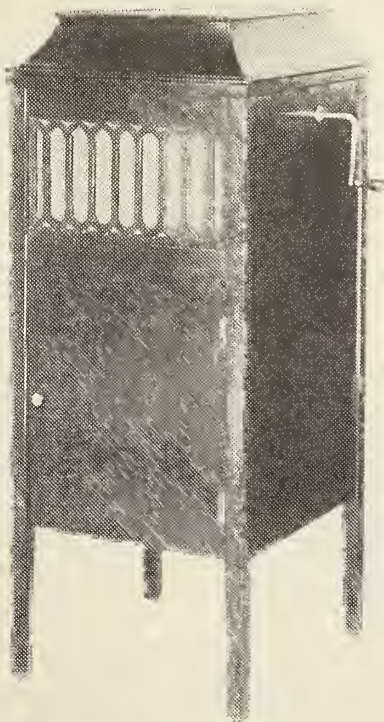

\$65 MODEL

Plays any Kind of Record—

Unexcelled Cabinet Work—

High Standard Mechanical Equipment

Send for Catalogue

Showing Other Styles and Description—

Liberal Discounts to Dealers

**SOUTHERN CALIFORNIA
HARDWOOD & MFG. CO.
1430 So. Alameda Street Los Angeles, Cal.**

Mr. Talking Machine Dealer

ARE YOU OVERLOOKING THE ONE BEST BET FOR MAKING ADDITIONAL MONEY THIS FALL? *YOU CERTAINLY ARE*—UNLESS YOU HAVE BOUGHT YOUR STOCK OF



LYRIC RECORDS



LYRIC RECORDS appeal because of their wonderful natural tone and musical quality—and because there is no surface scratch.

LYRIC RECORDS can be played without an attachment on all machines equipped with the universal tone arm; and on old-style machines, by using a standard attachment.

THE LYRIC CATALOGUE includes all that is best in the world's literature of standard songs, operatic arias, instrumental solos, band and orchestra records, etc.

NEW BULLETINS issued monthly, giving the best of the new song hits and dances.



INQUIRE OF YOUR JOBBER

OR WRITE TO

Lyraphone Company of America

Manufacturers

12-14 WEST 37th STREET

NEW YORK, N. Y.

**You've wanted it for years—
Here it is—
The Columbia Non-Set Stop!**



**Columbia Graphophone Co.
NEW YORK**

EXECUTIVES OF JOBBERS' ASSOCIATION HOLD SESSIONS

Over Two Score Members of National Association of Talking Machine Jobbers Attend Meeting in Philadelphia on September 9-10—Discuss Many Matters of Vital Importance, Including Questions of Supply and Increase in Prices—Hold Conference With Victor Co. Officials

PHILADELPHIA, PA., September 10.—The meeting of the executive committee of the National Association of Talking Machine Jobbers, which for a time threatened to reach proportions of a general convention, owing to the fact that the members in general had been invited to attend and had accepted, was held at the Hotel Adelphia, this city, yesterday and to-day.

It was a genuine wartime convention. There were serious problems to be considered and solved, and serious questions to be answered, but the wholesalers were apparently an optimistic lot, and felt that the trade situation could be trusted to work out all right in the end.

Yesterday morning the session was open to all members, and the executive committee took occasion to report to those present regarding the many developments in the trade since the last general convention, what action had been taken by the executive committee in the various cases, and what problems were confronting the talking machine men at the present time.

Discuss War Conditions

The members at large discussed the general situation and how the industry has been affected, owing to the war conditions and the curtailment of output occasioned thereby. They also talked over the best means for adjusting their respective businesses to meet the situation, how to overcome the problem of reduced production and the other developments that have already occurred or promise to occur in the near future. It was, of course, realized that the wholesalers would be obliged to act singly, and without regard to each other's actions, although it was felt that each one could profit through a general interchange of ideas.

It was the consensus of opinion of the wholesalers that an early increase in the list prices of Victrolas and records was not only desirable, but would prove necessary in order to cover coming increases in the war excise taxes and production costs. It was also emphasized that higher list prices were necessary to provide a sufficient margin between the wholesale and list prices to enable both wholesalers and retailers to finance their business successfully on a greatly decreased turnover. It was pointed out that, although the trade was going along right now, even in the face of loss of income, there was a danger point beyond which it was not safe to venture, and this danger point could be avoided only by increasing the income of those in the trade to offset decreased output.

Some Light on Legal Situation

At an open session in the afternoon the feature was the appearance of Gilbert H. Montague, attorney for the association, and counsel for the co-defendants in the suit brought against various Victor distributors in New York and vicinity by the Macy interests. Mr. Montague explained simply and unaffectedly the various

phases of the legal situation as it affects the talking machine trade, interpreted briefly the sense and scope of various recent important court decisions covering price maintenance and other matters, and cautioned the jobbers to so conduct their businesses so that they should not offer even circumstantial evidence of seeking to evade existing statutes and court rulings. The counselor explained at considerable length the rights that exist in the selection of customers by the individual, and then spent some time in answering legal questions of all sorts put to him by various members present.

At a subsequent session of the executive committee Mr. Montague was retained as association counsel, and the secretary was instructed to notify the membership that his services were available to the individual jobbers along the same lines in which his exhaustive experience had so well qualified him to act.

Following the open session the executive committee held a meeting for the consideration of matters to be brought up and discussed with the factory officials to-day, the meeting finally being adjourned until this morning.

At 1 p. m. to-day the visiting jobbers were entertained at luncheon at the Victor factory in Camden by the company officials, following which there was held a lengthy conference between the association officers and the officials and department heads of the Victor factory regarding questions of production, record exchanges and other matters of trade interest.

Victor Co. Officials Talk

Louis F. Geissler, general manager of the Victor Co., addressed the jobbers at some length regarding current conditions in the field, and explained particularly the effects of the war program in curtailing the output of Victrolas and records, as well as what might be expected along that line in the near future.

Ralph L. Freeman, secretary of the company and one of the organizers of the war committee of the talking machine industry, also addressed the jobbers regarding the situation in Washington and the attitude of the Government toward the trade. Mr. Freeman held a most optimistic viewpoint and declared that the offer of the talking machine men to co-operate with the Government in every particular had made an excellent impression on Government officials. He declared that there was apparently no desire to cripple the manufacture of talking machines and records, but that the trade was only subjected to curtailments and regulations in the matter of labor, materials and fuel to an extent found necessary in the case of all non-war industries.

Mr. Freeman stated that in the case of the Victor Co. the wishes of the Government had been anticipated and the curtailment of production was considerably beyond the official

minimum fixed, while at the same time the company was actually assisting the Government in filling contracts for war materials. During the course of the meeting it was brought out that there would probably come occasional readjustments of prices of Victrolas and records, to cover increased taxation and other higher costs of production and distribution.

Those Who Attended Meeting

Those present at the meeting included: President, J. Newcomb Blackman, Blackman Talking Machine Co., New York; vice-president, I. Son Cohen, Cohen & Hughes, Baltimore, Md.; treasurer, Arthur A. Trostler, Schmelzer Arms Co., Kansas City; secretary, J. C. Roush, Standard Talking Machine Co., Pittsburgh; E. C. Rauth, Koerber-Brenner Co., Kansas City; George E. Mickel, Mickel Bros. Co., Omaha, Neb.; James F. Bowers and L. C. Wiswell, Lyon & Healy, Chicago; W. H. Reynolds, Reynolds Music House, Mobile, Ala.; R. H. Morris, American Talking Machine Co., Brooklyn, N. Y.; C. N. Andrews, Syracuse, N. Y.; Louis Buehn, Louis Buehn Co., Inc., Philadelphia; Emanuel Blout, New York; W. H. Buescher, W. H. Buescher & Sons Co., Cleveland; Harry Goldsmith and S. E. Ruez, Badger Talking Machine Co., Milwaukee; C. F. Bruno, C. Bruno & Son, Inc., New York; Fred P. Oliver, Blackman Talking Machine Co., New York; J. G. Corley and Fred Kesnick, the Corley Co., Richmond, Va.; H. A. Winkelman, Oliver Ditson Co., Boston; T. H. Towell and C. K. Bennett, Eclipse Musical Co., Cleveland; A. A. Grinnell, Grinnell Bros., Detroit; J. F. Houck and W. S. Christian, O. K. Houck Piano Co., Memphis; Max Landay, Landay Bros., New York; E. Paul Hamilton, Frederick Loeser & Co., Brooklyn, N. Y.; C. Alfred Wagner, Musical Instrument Sales Co., New York; Jack Fisher, C. C. Mellor Co., Pittsburgh; A. D. Geissler, New York Talking Machine Co., New York; C. L. Price, Ormes, Inc., New York; T. W. Barnhill and H. F. Miller, Penn Phonograph Co., Philadelphia; Fred H. Putnam, Putnam-Page, Inc., Peoria, Ill.; Ernest Urchs, Phillips & Crew Co., Atlanta, Ga.; Thomas F. Green, Silas E. Pearsall Co., New York; Lester Burchfield, Sanger Bros., Dallas, Tex.; L. J. Gerson, John Wanamaker, New York; Perry B. Whitsit, Perry B. Whitsit Co., Columbus, O.; Rudolph Wurlitzer, Rudolph Wurlitzer Co., Cincinnati; Robert C. Rogers, Robert C. Rogers Co., Washington, D. C.; and A. Steinberger, Lit Bros., Philadelphia.

**SCHUBERT
Double Disc RECORDS**
A \$30 Record Investment Starts YOU with complete, up-to-date list of Popular Vocal and Instrumental Selections
10-INCH DOUBLE DISC
20 to 30 New Selections Monthly
We guarantee you against loss of Record Investment.
Liberal Discounts *Send for Details*
BELL TALKING MACHINE CORPORATION
(Record Department)
44 WEST 37th STREET, NEW YORK, N. Y.

Machines Will be Mighty Scarce This Fall

Build up your record business; train your sales force to understand the tremendous value of a profitable record business and be prepared to give your patrons efficient service and maximum convenience.

Van Veen Bed Set Booths

Will help you develop record business and enable you to give your customers 100% service.

*Let us show you how our booths can aid you.
Send for a copy of our catalog.*

Be a trade booster during war times; plan now for the future and your business will be in the front ranks when conditions become normal.

Arthur L. Van Veen & Co. 47 West 34th Street, New York
TELEPHONE . . . GREELEY 4749

HEARING ON STEEL FOR TALKING MACHINE TRADE

War Service Committee of the Talking Machine Industry Attend Hearing Before Priorities Committee of War Industries Board on Saturday Last to Discuss Steel Allotment

H. L. Willson, general manager of the Columbia Graphophone Co., and chairman of the War Service Committee of the Talking Machine

Industry, returned from Washington on Thursday morning of last week and reported that a hearing would be held before Judge Parker, of the Priorities Committee of the War Industries Board, on Saturday, September 14, to determine the basis upon which an allotment of steel and iron will be made to the industry for the coming six months' period. The procedure will probably be the same as that taken by the Priorities Committee in the case of other industries, including that of piano manufacturing, where a 33 1/3 per cent. allowance was made.

The members of the War Service Committee of the Talking Machine Industry who will attend the hearing on Saturday will include: H. L. Willson, chairman; Ralph L. Freeman, Victor Talking Machine Co.; E. A. Widmann, Pathé Frères Phonograph Co.; Charles A. Edison, Thomas A. Edison, Inc.; Arthur L. Cushman, Emerson Phonograph Co., and Joseph Schechter, secretary of the committee. Prospects for a fair allowance of steel and iron to meet the requirements of the industry are looked upon as being very favorable.

NEW YORK TIMES REVIEWS TRADE

Declares That There Is a Growing Demand for Machines of the Table Style

The New York Times of September 7 published the following review of conditions in the local phonograph trade, the interesting feature of which is a reference to the growing demand for table models of machines. The paragraph reads:

"Business in phonographs is becoming more active as the season develops. There has been during the last few weeks quite an increase of interest in the better quality machines. Some very expensive table cabinets in period styles have been sold. It is said that this type of cabinet, whether in period styles or in simple but artistic modern designs, is coming more and more into general favor. Though it is not anticipated that this table variety will displace the upright type of cabinet, there is every indication that it will figure prominently in the season's business."

BROOKS AUTOMATIC REPEATING PHONOGRAPH



THE WONDER INSTRUMENT

Plays and repeats any kind or size record—any desired number of times—then stops automatically with the tone arm suspended off to the right in the air. Any child can operate it.

WONDERFUL TONE **WONDERFUL FINISH**
WONDERFUL IN ITS SIMPLICITY

The Machine Creates Interest and Discussion.
It is Self-Advertising

WONDERFUL SELLER

DEALERS—Send for Particulars, Prices, Terms

BROOKS MFG. CO., Saginaw, Mich.

MAKE YOUR SHOW WINDOWS PAY YOUR RENT

Record Display Stands, Hold any Size Record Golden Oak or Mahogany Finish—5 Sizes

- No. 341. 1 Record \$1.00 ea.
- No. 342. 2 Records \$1.25 ea.
- No. 343. 3 Records \$1.50 ea.
- No. 344. 4 Records \$1.75 ea.
- No. 345. 5 Records \$2.00 ea.

THE OSCAR ONKEN CO.
No. 6651 4th St., Cincinnati, O.



INCREASE IN HOFFAY PRICES

Hoffay Talking Machine Co., Inc., Announces New Price Schedule on Machines, etc.

The Hoffay Talking Machine Co., Inc., announce the retail prices of the four types of Hoffay machines which they manufacture have been raised to \$125, \$175, \$225 and \$275 respectively. The wholesale discounts will remain the same as heretofore, but the Hoffay Co. will pay the war tax.

The retail prices of the \$10 nickel-plated and \$12.50 gold-plated "Resurrectones" remain the same, but in view of the advantages brought about by several improvements made in the new models, which means a reduction in assembling costs, the wholesale prices to dealers have been reduced, thus increasing the dealers' profits on this patented reproducer.

WANT MUSIC FOR SAILORS

Business Men Appeal for Instruments, Including Jews-harps

Many amusements which were formerly enjoyed by American sailors in the war zone are denied them now. For diversion at sea the men in the navy want mandolins, harmonicas, violins, banjos, talking machines and records, or even jews-harps.

An appeal is made to the public for such instruments by the Lower Wall Street Business Men's Association, 124 Front street, which will give them to sailors who are able to play them. Pianos, organs and melodeons will be received by special arrangement and through the Y. M. C. A. will be sent to a naval cantonment or ships in the war zone.

WANTS HIS EDISON STOCK AT ONCE

B. W. Smith, of The Phonograph Co., Cleveland and Cincinnati, Visits Edison Factory

B. W. Smith, of The Phonograph Co., of Cleveland and Cincinnati, large Edison jobber, made a special trip recently from Cleveland to the Edison factory in West Orange, N. J., to get earliest possible shipment of the Edison phonographs that he has on order.

Mr. Smith's dealers have made so heavy a demand upon him this summer that he was impelled to visit personally the Edison officials, hoping against his better judgment that he might obtain a much larger immediate shipment than he had been promised.



The Indoor Season

will be used by many for the study of languages. This spells opportunity for you, Mr. Dealer, through the

CORTINA Phone-Method

Sell them the records, the talking machine and the text books. The Cortina Military French-English course is especially adapted for those going "over there."

Send for full information. Advertising matter and window displays free.

The Cortina Academy
12 East 46th Street :: New York

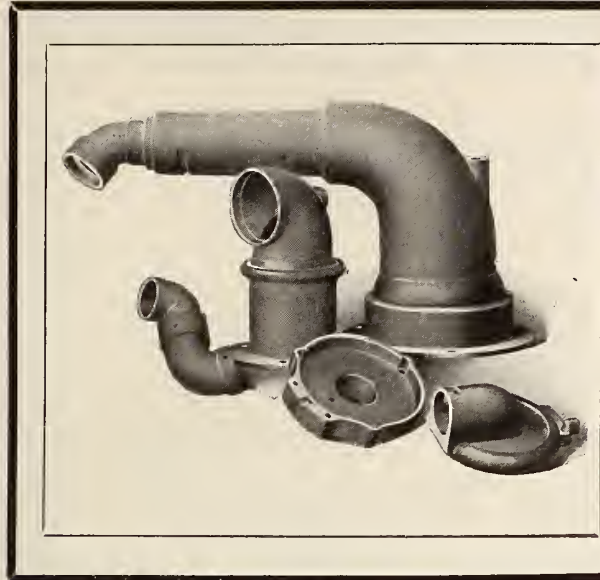

DOEHLER DIE-CASTINGS

for tone arms, sound boxes and talking machine attachments are STANDARD throughout the industry.

Of the many instruments produced to-day from the most prominent makes down, the greater number, by far, are equipped with Doehler die-cast tone arm and sound box.

The enormous output of our three large plants permits of advantages to the users of die-castings, as regards prices and deliveries, not otherwise possible.

DOEHLER DIE-CASTING CO.

MAIN OFFICE AND EASTERN PLANT
BROOKLYN, N. Y. WESTERN PLANT
TOLEDO, OHIO. NEW JERSEY PLANT
NEWARK, N. J.

DEVELOPING SALES ENERGY

A Timely Essay on a Timely Topic That Conveys a Timely Moral

There is a lot of meat in the following little essay upon developing sales energy which is well worth reading and then reading again, because it points out that to achieve we must work, and intelligent work means results. The article under the caption, "Don't be a Garabedian," appeared in the Peptimist and ran as follows:

"Garabed, you know, is the gentleman who thought—until an unkind and practical Congressional investigation dashed his hopes to bits against our ever present wall of hard facts—that he had discovered a method of summoning 'free energy' from the atmosphere.

"He hadn't. No one can.

"The energy which does things in this life isn't pulled out of air. It doesn't grow on trees. It is made out of sweat, muscle and hard work—years of them—and nothing else. Man has created energy from the powers around him—steam, electricity, fire, water—but the power was already there.

"Get the idea. You will never develop your sales energy out of nothing. You won't find it. It will not come like a rich uncle's will. You must create your own energy by seizing on all the powers around you and putting them to work. Here are a few:

"Books—read the good ones. Study biography. Learn from the records and achievements of others.

"People—associate with the successful ones. Study the methods of winners. Learn from men who know.

"Work—the one absolutely essential basis in every formula producing energy.

"And in all your generating of energy don't be a Garabed. Don't rely on luck, faith, chance or the gods. They may exist all around you but they are not the powers which create energy. You are the only power which can do that.

"YOU are your own energy maker.

"YOU are POWER."

PLAN BIG PROGRAM FOR MEETING

St. Louis, Mo., September 8.—After a meeting of the directors of the Tri-State Victor Dealers' Association it was announced that several members of the home office force of the Victor Co. would attend the annual convention of the association in this city October 23. Also that a Victor exclusive artist would be here to supply music for the convention. Caruso will sing at a concert given under his own auspices October 22.

It was stated by the directors that several members of the Victor home office staff had expressed a desire to meet the dealers when they gathered here and because so many wished to come, it would be necessary to decide who could be spared.

THE VIVITONE IN GREAT DEMAND

The New Tone Controller Introduced by the Vivitone Co., of Cincinnati, Wins Favor

CINCINNATI, O., September 6.—Talking machine dealers throughout the country are showing considerable interest in the invention of a well-known resident of this city, who has perfected a tone controller called the "Vivitone." This device has many distinctive features, and judging from the inquiries already received from the dealers, it will meet with signal success.

The Vivitone Controller Co., 400 Bell Block, is manufacturing this device, and in a recent letter to the trade it stated as follows: "There is not the slightest tendency to deaden or muffle the tone. All the harshness and mechanical stridency which so often mar fine records in their reproduction are taken away, while the richness of the natural voices and the true tones of the instruments are insured by the Vivitone. This much desired improvement in tonal quality is as marked in the machines that are costly as in the less expensive phonographs. Dealers are urged to give a practical demonstration of the device, not alone because the demonstration means a quick sale for the Vivitone, but for the added reason that records themselves take on unusual tone qualities, and therefore a greater desire for them is created."

The "Vivitone" is easily placed in the needle

post of any phonograph. It is not made of rubber, but is a tiny contrivance of fibre, specially treated for the purpose of bringing out phonograph tone quality. The Vivitone Controller Co. has been sending samples of its tone controller to established dealers in all sections of the country, and in return has received good-sized orders, together with many expressions of approval.

WILL REPRESENT VAN VEEN & CO.

Arthur L. Van Veen, president of Arthur L. Van Veen & Co., New York, manufacturers of "Bed-Set" booths, announced this week the appointment of Martin Katz as traveling representative for this company. Mr. Katz succeeds Leon F. Tobias, who is now a member of Uncle Sam's navy at Newport, R. I.

During the past month Mr. Katz has been visiting the dealers in metropolitan territory, and has assured them that he will co-operate with them in every way and endeavor to give them the same high degree of service extended by Mr. Tobias during his successful stay with the company. Mr. Katz is familiar with the dealer's problems anent store equipment, and he spent some time with Mr. Tobias visiting the trade before the latter joined the navy. Van Veen "Bed-Set" booths have been installed by dealers throughout the East, and numerous repeat orders testify to the satisfaction they are giving.



Record Cabinets

Made by
Nanes Art Furniture Co.
New York City

Record Envelopes



PIANO CREAM

is wonderful for restoring the lustre
to Talking Machines

"READY FILES" FOR RECORDS

CLEMENT BEECROFT

309 W. Susquehanna Ave.
PHILADELPHIA

Thirty desirable records. You may not have all of these selections
We will gladly play any record for you.

INSTRUMENTAL		VOCAL	
4001 [Record Title]	4002 [Record Title]	4003 [Record Title]	4004 [Record Title]
4005 [Record Title]	4006 [Record Title]	4007 [Record Title]	4008 [Record Title]
4009 [Record Title]	4010 [Record Title]	4011 [Record Title]	4012 [Record Title]
4013 [Record Title]	4014 [Record Title]	4015 [Record Title]	4016 [Record Title]
4017 [Record Title]	4018 [Record Title]	4019 [Record Title]	4020 [Record Title]
4021 [Record Title]	4022 [Record Title]	4023 [Record Title]	4024 [Record Title]
4025 [Record Title]	4026 [Record Title]	4027 [Record Title]	4028 [Record Title]
4029 [Record Title]	4030 [Record Title]	4031 [Record Title]	4032 [Record Title]
4033 [Record Title]	4034 [Record Title]	4035 [Record Title]	4036 [Record Title]
4037 [Record Title]	4038 [Record Title]	4039 [Record Title]	4040 [Record Title]
4041 [Record Title]	4042 [Record Title]	4043 [Record Title]	4044 [Record Title]
4045 [Record Title]	4046 [Record Title]	4047 [Record Title]	4048 [Record Title]
4049 [Record Title]	4050 [Record Title]	4051 [Record Title]	4052 [Record Title]
4053 [Record Title]	4054 [Record Title]	4055 [Record Title]	4056 [Record Title]
4057 [Record Title]	4058 [Record Title]	4059 [Record Title]	4060 [Record Title]
4061 [Record Title]	4062 [Record Title]	4063 [Record Title]	4064 [Record Title]
4065 [Record Title]	4066 [Record Title]	4067 [Record Title]	4068 [Record Title]
4069 [Record Title]	4070 [Record Title]	4071 [Record Title]	4072 [Record Title]
4073 [Record Title]	4074 [Record Title]	4075 [Record Title]	4076 [Record Title]
4077 [Record Title]	4078 [Record Title]	4079 [Record Title]	4080 [Record Title]
4081 [Record Title]	4082 [Record Title]	4083 [Record Title]	4084 [Record Title]
4085 [Record Title]	4086 [Record Title]	4087 [Record Title]	4088 [Record Title]
4089 [Record Title]	4090 [Record Title]	4091 [Record Title]	4092 [Record Title]
4093 [Record Title]	4094 [Record Title]	4095 [Record Title]	4096 [Record Title]
4097 [Record Title]	4098 [Record Title]	4099 [Record Title]	4100 [Record Title]

IMPORTANT NOTICE

TO THE AMERICAN TRADE

The Sterno Manufacturing Company
19 CITY ROAD LONDON, E. C. ENGLAND

Manufacturers of the world known COMPACTOPHONE—the most complete portable gramophone extant—beg to announce the conclusion of arrangements for the EXCLUSIVE SELLING RIGHTS IN THE UNITED STATES OF THE

High Grade Motors Manufactured By **Mermod Freres** St. Croix Switzerland

WONDERFUL MECHANISM

These motors represent the acme of workmanship and quality. Each part is made to the finest gauge limits and assembled to run with the precision of a watch—silent and true. Messrs. Mermod Freres is an old established Swiss manufacturer. Back of their motors are years of hard practical experience. The experimental stage was left behind a decade or more ago. Reliability and quality is therefore assured.

DIFFERENT MODELS

Mermod Freres motors comprise several types—single and double spring worm and pinion-gear drive, the very latest and scientific method of construction.

CONSULT US

Before placing your orders elsewhere consult us as to prices and terms of trading. We are out for quick shipments and prompt delivery direct from the factory to the buyer.

SPECIAL TERMS TO JOBBERS

Within the near future it is proposed to establish
A CENTRAL DISTRIBUTING DEPOT IN NEW YORK
Meanwhile trade enquiries should be directed to

THE STERNO MANUFACTURING CO.
19 CITY ROAD LONDON, E. C. ENGLAND

How Best to Keep the Prospect Interested in Your Selling Argument :: :: :: :: By Henry Jenkins

The local agent for a high-grade talking machine in a small town had a prospect with whom he had no success. The man was a weather-beaten old farmer who admitted that he was planning to buy a good talking machine for his daughter, but it was impossible to get him down to a definite selection. Perhaps he could not make up his mind to part with so much money. The general agent of the manufacturer happened into that territory and the local man brought him and the farmer together. The general agent was a super-salesman in his field.

Agent and farmer sat down in the local man's office and the high-priced salesman began on the rugged prospect. As a demonstration in scientific salesmanship, the selling talk was a wonder. The old farmer sat there, looking now at the salesman, now at the local agent

and now at the gnarled and knotty hands he was somewhat nervously twisting.

The salesman approached the culminating point in his talk. He began to unfold his order blank. The local agent got out his fountain pen and removed the cap, placing it on the other end. At the right psychological moment the general agent paused in his talk, reached out with the order blank and the old farmer spoke for the first time. "Say," said he, "d'you know of anything that'd take that wart off my thumb?"

Every salesman knows what it is to be putting forth his best efforts to interest the prospect, only to have that prospect's attention wander and his gaze turn to the window or elsewhere. That is the end of many a selling talk.

When the prospect's mind begins to wander it is the time for emphatic and immediate initiative on your part. You must start something interesting to him and important in its bearing on his interests, and you must do it right away or give up. If you have nothing up your sleeve you are not a resourceful salesman and you will not land the difficult prospect, no matter how hard you try.

If you have anything else to offer, that is the time to offer it and to bring back the wandering interest of the customer. There is no sale to be made to the man whose attention you are not keeping and it requires high tension brain work on your part to hold attention when there is a tendency for it to drift to other things. You cannot let up on your own interest and retain the prospect's interest.

SOME NEW RULES FOR EXPORTERS

Conditions Under Which Pianos and Phonographs May Be Shipped to Denmark and Holland Announced by War Trade Board

Following the announcement of the War Trade Board to the effect that certain specified articles, including phonographs, pianos and records, could be exported to European Holland and Denmark, the following regulations have been issued covering the exportation of goods to those respective countries:

Prospective importers in European Holland should obtain from the Netherlands Overseas Trust Co. an import certificate. Upon receipt of the certificate, the importer should notify the prospective exporters that such a certificate has been obtained and advise him of the serial number thereof. The exporter should thereupon apply to the War Trade Board, Bureau of Exports, Washington, D. C., for an export license, using Application Form X and such supplemental information sheets concerning the commodity as are required, and, in addition, furnish on Supplemental Sheet X-102 the gross weight of the proposed shipment and the serial number of the Import Certificate of the Netherlands Overseas Trust Co.

All shipments to European Holland, except those consigned to the Government of the Netherlands, must be consigned directly to and only to the Netherlands Overseas Trust Co. (W. T. B. R. 77, March 15, 1918).

In the case of proposed shipments to Denmark, the prospective importer abroad first should obtain an import certificate from the Merchants' Guild of Copenhagen or the Danish Chamber of Manufacturers. When this certificate is received, the prospective importer should advise the exporter in the United States of the serial number. Application for export licenses should be made on Application Form X, and the applicant should attach thereto the appropriate supplemental information sheets, and also Supplemental Information Sheet X-105, upon which should be noted the Merchants' Guild of Copenhagen, or the Danish Chamber of Manufacturers' Import Certificate Serial Number. Such shipments need not be consigned to the Merchants' Guild of Copenhagen or the Danish Chamber of Manufacturers, but may be consigned to an individual or company in that country.

Licenses will be valid only for shipment on vessels flying the flag of the country to which commodities are destined.

ALBERT NEWBAUER'S NEW POST

Albert Newbauer has been appointed manager of the dealer service department of the local wholesale branch of the Columbia Graphophone Co., 55 Warren street. Mr. Newbauer

succeeds Wm. A. Schreiner, who resigned from this position the first of the month.

The Columbia dealer service department in New York has been meeting with considerable success, and as Mr. Newbauer has been associated with the local branch for some time he

has an intimate knowledge of the dealer's requirements. This department has introduced many practical ideas during the past year, which have served to stimulate the demand for Grafonolas and Columbia records throughout local territory.



THE IMPROVED No. 10



RECORD BRUSH

Patented Sept. 26 and Oct. 2, 1906
Sept. 10, 1907, and Nov. 27, 1917
Others Pending



NICKEL PLATED 35 CENTS **GOLD PLATED 75 CENTS**

For Victor Victrolas

DOES THE WORK

Automatically Removes Every Particle of Dust and Grit from the Record Grooves

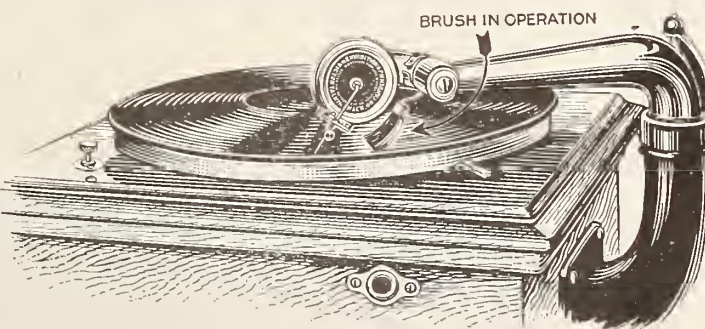

**Your Customers Need Them
You Should Have Them**

Order From Your Distributer

Manufactured by



Blackman
TALKING MACHINE CO.
97 CHAMBERS ST. NEAR CHURCH ST. NEW YORK



Victor Distributers

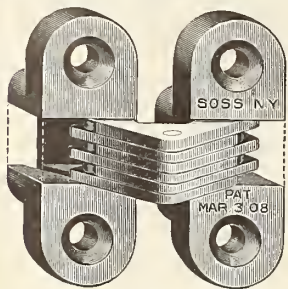

No. 103

SOSS

INVISIBLE HINGES

Preserve Beauty

In many beautifully designed, finely finished Talking Machines, Pianos, Music Cabinets, Piano Players and Benches, the elimination of the unsightly protruding Hinge is essential to preserve the beauty of the design.

Design and Construction

The fine cabinet work which is required in many instances to preserve the disguise of the instrument requires that the hinges be as inconspicuous as possible. SOSS Hinges are *invisible*.

WRITE FOR CATALOGUE "T"

SOSS MANUFACTURING COMPANY, 435 Atlantic Avenue, BROOKLYN, N. Y.

DETROIT—922 David Whitney Bldg.
SAN FRANCISCO—164 Hansford Bldg.

LOS ANGELES—600 Metropolitan Bldg.
CHICAGO—John C. Bold & Co., Clark and Washington Sts., Conway Bldg.

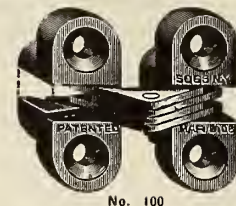

No. 100

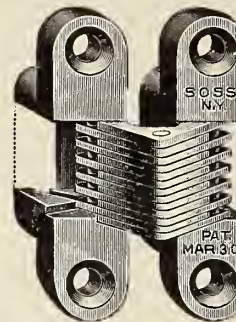

No. 101

THREE NEW BEAUTIFUL MODELS OF PERIOD GRAFONOLAS

New Styles Are Most Distinctive and Embody Many New Constructive Features Apart From Their Handsome Casings Which Will Merit the Approval of the Purchasing Public

The Columbia Graphophone Co., New York, has added to its extensive period cabinet line the three new models shown in the accompanying illustrations. These new designs have vari-

ous distinctive features, and Columbia dealers have evidenced their approval of these instruments by placing large-sized orders for immediate delivery. The company expects to have these models in the hands of the dealers October 1.

console tables from a manufacturer of the most expensive high-grade furniture. These tables were sent to the Columbia Co.'s period model factory, where they were faithfully reproduced in every detail.

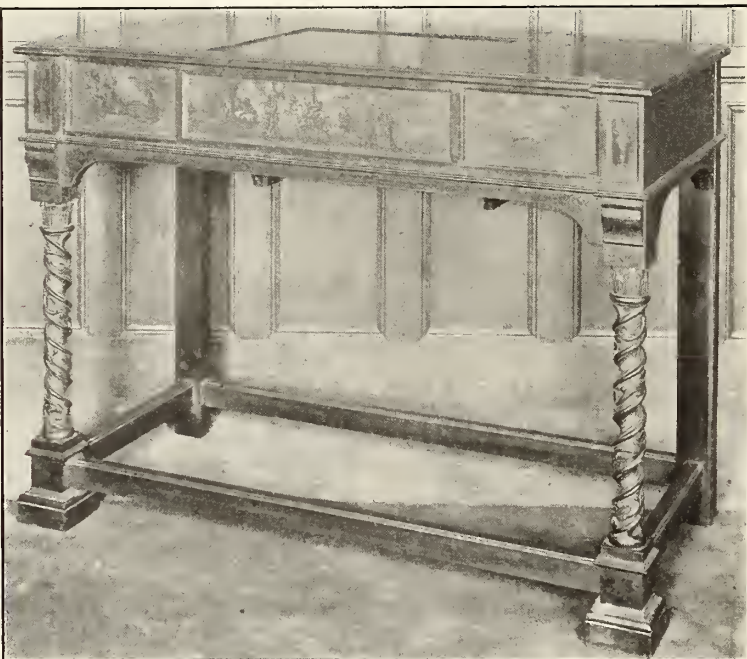

Columbia Console Model, Decorative Italian

After the models had been completed the installation of the Grafonola mechanical equipment received the attention of the Columbia experts. The tone passes through two horns and these horns are covered by panels on each end. The center panel in each model is stationary. The construction of these horns was an interesting and difficult feat, as they were built exactly like a pair of animal horns. The experiment was a decided success, and the tone quality in the console table models has won the approval of hundreds of visitors to the company's showrooms.

ders for these instruments for well-known music-lovers. In fact, the entire Columbia period model line is meeting with a ready sale,



Columbia Console Model, in Mahogany and the company has been congratulated by its dealers upon the artistic qualities and sales possibilities of these instruments.

ADVERTISING AND PROSPERITY

The Influence of Advertising Most Potential, as Pointed Out Recently by J. H. Neal

Advertising is not a luxury in which pride-puffed manufacturers indulge themselves, but is a force which has been responsible for American prosperity, declared Jesse H. Neal, of New York, executive secretary of the Associated Business Papers, Inc., in addressing the Ways and Means Committee of the House of Representatives recently on the postal zone rate law.

"More than any other one force," he said, "modern advertising is responsible for the prosperity of United States industry. The great majority of our improved manufacturing, selling and distribution methods have been the outgrowth of advertising; advertising which has scrapped obsolete machinery; advertising which has standardized production operations; advertising which has made better merchants and distributors; advertising which has provided consumer markets at a minimum of cost.

"All of this has enabled quality production, by economical processes, and has enabled us to pay higher wages than any other country and yet to be able to compete in the markets of the world, with the low-paid and oppressed workmen of less progressive countries."

ARTHUR E. NEALY GOING OVERSEAS

Arthur E. Nealy, formerly connected with the Chicago office of The Talking Machine World, and who entered the military service last September, visited The World office this week while on the last leg of his journey "over there." Private Nealy is a member of the Signal Corps, and since entering the army has been in training near Rockford, Ill.

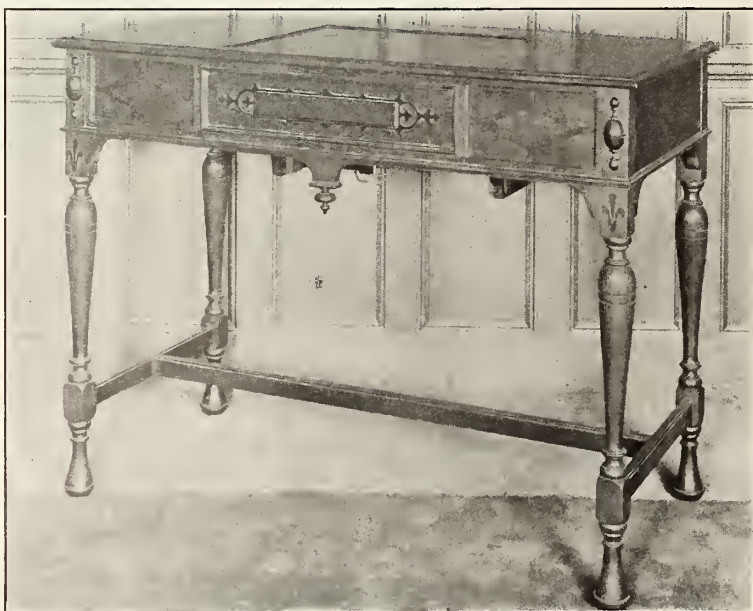

Columbia Console Model, in Oak

ous distinctive features, and Columbia dealers have evidenced their approval of these instruments by placing large-sized orders for immediate delivery. The company expects to have these models in the hands of the dealers October 1. For several months past the Columbia Co. had received requests from its dealers to include in its period cabinet line console table designs, and the company decided recently that these designs would be welcome additions to the series of Columbia art models, which have already achieved remarkable success throughout the country. In order that the new models be absolutely true in their design, arrangements were made to purchase three artistic

SONORA DEALERS IN CANADA MEET

First Annual Convention of Canadian Dealers Held Under the Auspices of I. Montagnes & Co., Sonora Jobbers for the Dominion

TORONTO, ONT., September 7.—The Sonora dealers in Canada were the guests of I. Montagnes & Co., of this city, this week to attend the first annual convention of Sonora dealers in this territory. I. Montagnes & Co. are Sonora distributors in Canada and number among their clientele some of the largest music dealers in the Dominion.

About seventy-five dealers accepted the company's invitation to attend this convention, and assembled at the King Edward Hotel on Tuesday, September 3. At luncheon an address of welcome was extended by I. Montagnes, and the opening session was marked by the reading of several interesting papers prepared by George E. Brightson, president, and Joseph Wolff, treasurer of the Sonora Phonograph Sales Co., New York. Frank J. Coupe, advertising and sales director of the Sonora Phonograph Sales Co., attended the convention personally, and gave a splendid address entitled "Special Sales Helps for Dealers." John Fullerton, publisher of the Canadian Music Trade Journal, also favored the dealers with an excellent talk under the heading of "Music in the Home." The opening day came to a close after the party had visited the Toronto Industrial Exposition.

On Wednesday afternoon the dealers heard several practical talks, among which were the following: "Romance of Advertising," by Mr. Solomon and Miss Hansler, of the Advertising Service Co., Toronto; "Repairing and Adjusting," by Mr. Farb, superintendent, Sonora Phonograph Sales Co.'s factory; "Retail Merchandising of Yesterday and To-day," H. V. Kautzmann, wholesale representative, I. Montagnes & Co.; "Methods of Securing and Following Up Prospects," H. R. Braid, manager Sonora Retail Studios, Toronto; "How Orders Should Be Placed," E. H. Van Gelder, I. Montagnes & Co.

GREAT MANUFACTURING PLANT IN SOUTHERN CALIFORNIA

LOS ANGELES, CAL., September 4.—The Southern California Hardwood & Mfg. Co., of this city, has been achieving splendid success with its line of Hawthorne phonographs. The company

The Southern California Hardwood & Mfg. Co. occupies the largest and oldest woodworking plant in the West; this plant covering eleven acres. The company has won country-wide



View of the Plant of the Southern California Hardwood & Mfg. Co.

has placed this line with some of the most successful dealers on the Coast, and judging from the orders on hand the factory will be obliged to work to capacity this fall to fill orders booked.

prominence in the woodworking field, and the success of the Hawthorne phonograph is a tribute to the prestige of this company in manufacturing circles.

On Wednesday evening a banquet at the King Edward Hotel was one of the most enjoyable events of the convention, and every dealer present expressed his appreciation of the splendid program which had been prepared for the convention and evinced keen interest in the informal addresses at the banquet.

On Thursday morning the dealers attended demonstrations of the Sonora products in the

warerooms of I. Montagnes & Co., and in the afternoon were the guests of the company at various forms of entertainment. The convention was a decided success, serving to indicate the tremendous popularity of the Sonora phonograph in Canada, and reflecting the spirit of cooperation which exists between I. Montagnes & Co. and the Sonora dealers throughout the Dominion.

TRIBUTE TO BRUNSWICK PUBLICITY

The life-size cardboard cut-out figure of the Brunswick girl has attracted attention wherever shown. In Danielson, Conn., it has attracted the attention of the daily press. The Transcript, published in that city, comments as follows: "Chicago has become famous for many things,

and among them is the large number of beautiful women who live there. One of these Western beauties is on a visit to Danielson and all who admire real perfection of face and figure should see her. Her name is Iona Brunswick, and she is visiting at 99 Main street, where she will be pleased to greet and entertain all who wish to make her acquaintance."

ADD TO YOUR FALL PROFITS

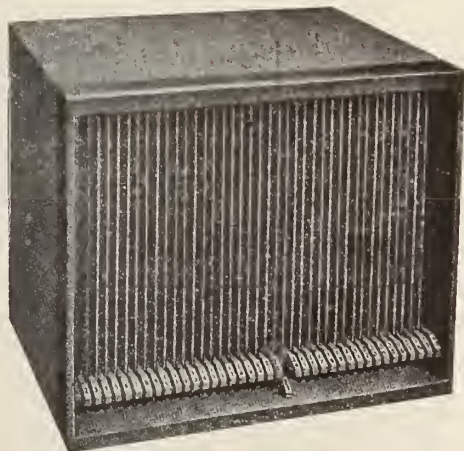

Style 70—Retail \$10.00

Figure the profits on your machines and then figure how much more could be added if an Eject-O-File was sold at the same time.

Eject-O-Files are built to fit:

- COLUMBIA Style 75
- VOCALION Styles F, G, H, I, J, K, and
- EDISON Styles C150 and 100.

A highly efficient record filing device that produces the record wanted at the touch of a finger. It appeals and very often sells itself.

Retails at \$10. In beautiful oak or mahogany finish. Polished, wax or dull finish. Write for descriptive circular and details so that you may see the opportunities this line holds for you.

EJECT-O-FILE SALES CO.

216 W. SARATOGA STREET



BALTIMORE, MD.



Competition can't touch the Columbia Dealer on the Non-Set Stop! It's protected by hundreds of claims—

Columbia Graphophone Co.
NEW YORK

PORTLAND'S EXPANDING POPULATION STIMULATES SALES

Talking Machine Men Enjoy Full Share of Increased Buying Power During Summer Months—Delays in Shipments Cause Losses—New Makes of Machines Appear in the Field

PORTLAND, ORE., September 4.—Rarely has Portland experienced such a summer as that just closing. Business in all lines has been big and the talking machine departments of the big music stores have been fairly swamped with orders which have made great inroads on the stocks of machines and records. Dealers are all wondering where they will possibly get enough stock to supply the fall trade, which is starting off with a whoop, and there is hardly a music house in town which isn't planning enlargements of space, employed force and stock to get ready for what promises to be the biggest fall and holiday trade the Pacific Northwest has ever experienced.

Recent estimates of population in Portland are 350,000, or 75 per cent. greater than the population of two years ago. The added population has been brought by 40,000-odd shipbuilders and their families, who are spending freely of the big wages, and thousands of lumber and mill workers who are in the same condition of financial ease as are the shipbuilders. This big added population has come to Portland without appreciably increasing the number of business houses, and as a result the talking machine dealers, who last year were supplying 200,000 people, are now being called on to supply a much greater number of far better paid workers. The answer is business beyond the dreams of the dealers, who find only two causes for worry—shortage of stock and scarcity of competent experienced help.

Business has been exceptionally good in the talking machine department of the Wiley B. Allen Co. Sales in August ran large with many C-250 Edisons being disposed of as well as a

large number of Brunswicks of the larger patterns. A shipment of Victrolas was received this week at this house and did something to ameliorate a severe stock shortage, but the house still falls far short of having enough Victrolas to meet the demand, in spite of recent big shipments. Paul B. Norris, manager of the Victrola department, sold fourteen machines in one day right off the floor, and he says the call for Victrolas is far in excess of the supply. Sales of Brunswicks have been a big feature of this house's business, the recently added line supplementing the Victrolas, Edisons and Cowan Classique, in all of which lines Wiley B. Allen's Portland house is now doing a splendid business. Splendid window displays have been the rule at this house for the last month, and Mr. Norris says the results have been appreciable.

Louis T. Older, assistant manager of the Columbia Graphophone Co., says his house could sell ten carloads of Columbia machines between now and Christmas if the machines could only be obtained from the factory. About all the records obtainable, too, could be disposed of, Mr. Older says. So insistent has been the call for records that all shipments are now coming by express. "The Columbia has increased its business 100 per cent. over that of a year ago," said Mr. Older. "We have interested dealers in the new non-set stop machine and the result has been a lot of business."

Sales of records dropped off a trifle in August, not quite reaching the July mark at the Columbia house, owing to stocking up by the public in July in preparation for the advance in price which had been advertised for August 1. Sales

toward the end of August, however, picked up remarkably and September business has started off in such fashion that the previous high-record month of July will probably be eclipsed.

The Columbia house received a carload of machines the first week in September, this being the first substantial shipment in six months. Nearly all these machines have already been disposed of. He reports unfilled orders in Portland of \$15,000. Stock is absolutely exhausted in many types of machines.

The G. F. Johnson Music House has been having a big run of business in its talking machine department, but has been experiencing trouble in obtaining Victor machines. The Cheney phonograph has been added to the line carried by the Johnson house and the Cowan Classique has also been put in. As a result the Johnson Music House has been able to meet calls for talking machines, but has been forced to turn down countless orders for certain makes and switch customers to other models. Robert Callahan, manager of the Victrola department, with the assistance of Miss Leda Hayes, in charge of the record department, has been busy taking an invoice of records and machines. The G. F. Johnson house has branched out and now has in operation a store at Vancouver, Wash., where pianos and Victrolas are sold. Without doubt the new store will share in the general prosperity of Vancouver, where 6,000 troops are stationed, 2,000 in the big Government cut-up plant, and where thousands of workers are engaged in the shipyards.

Bush & Lane has been having a good sale of the Sonora portable machine and the demand for this instrument is constantly increasing. An attractive display of these nifty little instruments in their leather cases in the Bush & Lane windows has attracted a great deal of attention. James Loder, manager of the Bush & Lane phonograph department, says many campers and automobile parties have been buying the portable Sonora since its appearance in Portland. A number of dancing clubs have also bought them and they are carried from house to house of different club members, who are well satisfied with the tone of the small but perfect phonograph. Bush & Lane has been feeling seriously the shortage of Victor machines. Sales during August have been large in the record department, Mr. Loder attributing much of the success of this department to the addition of Miss Beatrice Finzer to the sales and office force.

Business in the talking machine department of the Meier & Frank store has continued very good. W. J. Matney, head of the department, sold \$840 worth of instruments in one day and says that every day is good with business on the whole much better than it was at this time last year and collections far ahead of what they have ever been.

The Stradivara talking machine was not well known to the public of Portland until the recent opening of the Sahlstrom Corp. L. E. Gilham, manager of the company, says the prospects for business in September are better than any month

Bring Those Jobs Out of Hiding

The value of your "job lots" will not be increased by keeping them on your shelves.

Bring them out into the daylight. Let us sell them for you.

We are in the market to buy for cash everything in Phonograph parts, accessories, etc.

Get in touch with us at once

THE PHONOGRAPH CLEARING HOUSE, Inc.

51 EAST 42d STREET, NEW YORK CITY

since the corporation has been in business—April. Many Stradivaras are being sold, and they are becoming more popular as the Portland public is becoming acquainted with them.

Graves music store reports an excellent talking machine business. C. A. Norman, of the talking machine department, reports trouble in obtaining enough popular records to meet the demand.

C. Guy Wakefield, of the Wakefield Music House, reports the sale of fifteen Brunswick phonographs in the last month. This is a small store whose business steadily grows.

Brunswicks also have been selling well at the Soule Bros. Music House, where there is a fine stock of machines on hand.

The talking machine trade has had quite a number of changes in Portland in the last month. Recent additions to the talking machine department of the G. F. Johnson Music House are Miss Gladys Bozlie and Mrs. J. C. Myers. Both supplanted men who had been taken in the draft and both are showing the value of women in carrying out the work formerly done by men.

L. S. Geer, formerly with Calef Bros. branch store at Salem, Ore., is now with the main store in Portland and is very much interested in the sale of Pathé phonographs which the firm carries.

J. R. Haight, of the Columbia Graphophone Co., is now managing the Dictaphone department during the absence of L. C. Callahan, who is at the officers' training camp at the University of Oregon at Eugene, Ore.

A marriage of interest to the trade is that of Miss Alma Hardman, formerly with the phonograph department of the G. F. Johnson Music Co., of Portland, and Howard Van Sweringen, of Chicago, who was formerly with the Cable Company, in that city.

Another woman who has taken a position in the talking machine field supplanting a man who has gone to the war is Miss Averil Temple, who has joined the forces of the Hyatt Talking Machine Co.

L. D. Heater, manager of the Columbia Graphophone Co. branch, is on a vacation. Mr. Heater is a great fisherman and can catch fish where no one else can hook any.

The assistant auditor of the Columbia Graphophone Co., T. A. Laurie, is spending two weeks in Portland looking after the business interests of his firm.

John Monroe, seventy-two years old, who, when a resident of Portland several years ago, made records that went to all parts of the United States and to foreign countries, was a visitor in this city at the National G. A. R. encampment. Mr. Monroe's home is at Portland, Me. Back in 1898 on September 1 Mr. Monroe gave a concert in the Portland Opera House with an old style phonograph, using the records he himself made, taking in \$400 in one hour and forty minutes.

The talking machine business was well represented in the B. P. O. Elks parade in Portland August 28, many of the talking machine men being Elks.

LETTERS "FROM THE FRONT"

Roy J. Keith Receives a Number of Interesting Letters From Former Members of the New York Talking Machine Co.'s Sales Staff

Roy J. Keith, vice-president and general manager of the New York Talking Machine Co., received during the past few weeks several interesting letters from abroad, written by the former members of the New York Talking Machine Co.'s sales staff. These boys are in active service on the Western front, and their letters reflect the spirit of enthusiasm and valor which is playing such an important part in the magnificent offensive of the Allies.

One of the most interesting letters received by Mr. Keith was sent by W. G. Porter, who was recently awarded the Croix de Guerre for signal bravery under fire. In addition, Mr. Porter has just been made a top sergeant, and the following paragraph from his letter to Mr. Keith tells how this happens:

"We had a bit of hard work and luck before entering this sector. For four days and three nights in the early part of June we were in the lines with our division behind Soissons and it's a cinch that they have been the hardest days of my young life. At the time our division occupied the sector, the fighting was fierce and the bombardments more intense and terrific than I had ever imagined. Every minute of the time in the sector every man of us was on the job, with no sleep and very little to eat. To work under these conditions along roads that old Fritz peppered with his big boys was a bit hard on the nerves. We all had our narrow escapes but everything was rosy until our very last morning in the sector, when Fritz came over and advanced some eight kilometers. There were nine of us covering the outposts at the time and four of us got through and the other five didn't; two of the boys were killed and two more captured, from the fifth we have heard nothing, but we're all hoping he, too, is a prisoner. One of the captured boys' ill fortune proved to be my good fortune, for our chief hopped me into his place as top sergeant of the tribe, which pleased me no little."

Charles Mason, who is a member of the Ambulance Corps, also somewhere in France, left Camp Green in this country some five weeks ago, and describing his trip across the ocean, says as follows:

"The first half of our journey across the big puddle was very pleasant and in fact the whole trip was pretty good with the exception of a few times when the boat rolled around a bit. It was decidedly inconvenient to be seasick, so nearly everyone refrained. Toward the end of the trip the monotony was relieved by a little argument with a submarine. I was fortunate enough to see the whole party, which, by the way, was over in less than a minute. The submarine will be very peaceful from now on."

Corporal Wm. C. Griffith, formerly assistant sales manager of the Chicago Talking Machine Co., who is now at Camp Wheeler, Ga., gives Mr. Keith an interesting account of conditions down South, and a paragraph from his letter read as follows:

"Thanks a lot for your letter and particularly for the wonderful sentiment expressed in it. You certainly have the right dope on this war. Geo. Ade sums up the whole situation when he says that 'Anyone who has more money at the close of the war than before it started automatically is put in a class of porchclimbers.'"

Max Gottlieb left New York four months ago and is now at La Courtine, France. He writes optimistically and seems generally pleased with conditions abroad. Some of his comments are as follows:

"I have received just one Voice of the Victor for May since I have been over here but no World. I found this very interesting and hope the Victor Co. will continue sending it.

"We expect to leave this place shortly and I hope it is to give us a chance at the enemy. I don't think it would be very healthy for them, as our boys sure did hit the target. Our battery

is an 8-inch howitzer battery, and she sure does tear some holes."

Wilbur Fox, one of the company's packers, went to Camp Upton in November, 1917, as a private, being appointed a corporal one month later. Two months later he was promoted to the post of sergeant, which position he held when the troops left for France. Word has just been received from abroad that in a recent engagement four toes were shot off Mr. Fox's right foot, and he distinguished himself for valor and leadership. He has in consequence been appointed a second lieutenant, and is being sent back to this country to act as an instructor.

BECOMES MANAGER OF DEPARTMENT

E. G. Bryson, who was formerly connected with the New York offices of the Brunswick-Balke-Collender Co., has joined the forces of Koch & Co., New York department store, where he has been made manager of the phonograph department which carries the Brunswick line.



Where Dealers May Secure

COLUMBIA

Product

Ready, Full Stocks, and Prompt Deliveries from Convenient Shipping Centers all over the United States.

Distributors

- Atlanta, Ga., Columbia Graphophone Co., 63 N. Pryor St.
- Baltimore, Md., Columbia Graphophone Co., 16 South Howard St.
- Boston, Columbia Graphophone Co., 137 Federal St.
- Buffalo, N. Y., Columbia Graphophone Co., 737 Main St.
- Chicago, Ill., Columbia Graphophone Co., 14 N. Michigan Ave.
- Cincinnati, O., Columbia Graphophone Co., 427-429 W. Fourth Ave.
- Cleveland, O., Columbia Graphophone Co., 1375 Euclid Ave.
- Dallas, Tex., Columbia Graphophone Co., 1011 Elm St.
- Denver, Colo., Columbia Stores Co., 1608 Glenarm Place.
- Detroit, Mich., Columbia Graphophone Co., 401 Woodward Ave.
- Indianapolis, Ind., Columbia Graphophone Co., 207-217 W. Washington St.
- Kansas City, Mo., Columbia Graphophone Co., 1027 McGee St.
- Los Angeles, Cal., Columbia Graphophone Co., 745 S. Broadway.
- Minneapolis, Minn., Columbia Graphophone Co., 412-414 Nicollet Ave.
- New Haven, Conn., Columbia Graphophone Co., 206 Meadow St.
- New Orleans, La., Columbia Graphophone Co., 517-525 Canal St.
- New York City, Columbia Graphophone Co., 55 Warren St.
- Omaha, Neb., Schmolter & Mueller Piano Co.
- Philadelphia, Pa., Columbia Graphophone Co., 210 N. Broad St.
- Pittsburgh, Columbia Graphophone Co., 632-640 Duquesne Way.
- Portland, Me., Columbia Graphophone Co., 43 Exchange St.
- Portland, Ore., Columbia Graphophone Co., 429-431 Washington St.
- Salt Lake City, Utah, Columbia Stores Co., 221 South West Temple.
- San Francisco, Cal., Columbia Graphophone Co., 130-150 Sutter St.
- Seattle, Wash., Columbia Graphophone Co., 811 Western Ave.
- Spokane, Wash., Columbia Stores Co., 818 Sprague Ave.
- St. Louis, Mo., Columbia Graphophone Co., 1127 Pine St.
- Tampa, Fla., Tampa Hardware Co.

Headquarters for Canada:

Columbia Graphophone Co., 54-56 Wellington St., West, Toronto, Ont.

Executive Office

COLUMBIA GRAPHOPHONE CO. Woolworth Building New York

MAESTROLA MAHOGANY CABINET MACHINES, SIZE 15 x 15 x 7 1/2

Motor worm gear plays 2 1/2 to 3 ten inch records, one winding. Prices \$4.50 in 100 lots, in dozen lots \$5.00 each, sample machine \$5.50. Cash with order.

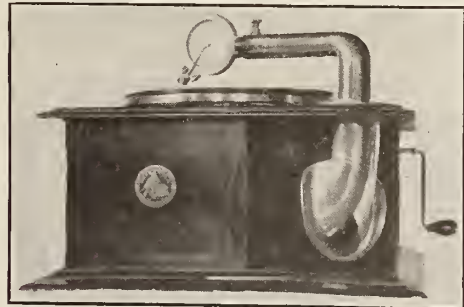

Steel needles and phonograph parts selling at the old prices during September regardless of the scarcity of these supplies. Now is the time to place your order. Be wise and save money.

FULTON TALKING MACHINE COMPANY 640 Broadway New York City, N. Y.

WORLD'S CLASSIFIED ADVERTISING

Any member of the trade may forward to this office a "Situation" advertisement intended for this Department to occupy a space of four lines, agate measure, and it will be inserted free. Replies will also be forwarded without cost. Additional space will be at the rate of 25c. per line. If bold faced type is desired the cost of same will be 25c. per line.

SALES EXECUTIVE of high caliber with a past record of things accomplished and who has recently placed on the market with signal success one of the representative talking machine lines in the trade will consider new connection. My highly specialized services will be of particular value to some big live concern ambitious to become or continue real factors in the talking machine field. Address "Box 554," care The Talking Machine World, 373 Fourth Ave., New York.

CAN PLACE SALES PERSONS—We can place a number of local phonograph sales persons in towns of from 5,000 to 15,000. Experienced in phonograph or piano sales work, compensated by salary and commission. Address "Box 545," care The Talking Machine World, 373 Fourth Ave., New York.

WANTED—Man between twenty-five and forty years of age with \$5,000 to invest in a corporation operating a chain of Columbia Talking Machine stores. Party must be capable of managing a branch store. Liberal salary with chance for advancement to right party. Address "Box 541," care The Talking Machine World, 373 Fourth Ave., New York.

SALESMEN WANTED—If you cover the phonograph trade in any section of the United States and are interested in a live proposition, either as a side line or as your main line, we have an interesting offer. In answering state territory now covered. Address "Box 522," care The Talking Machine World, 373 Fourth Ave., New York.

WANTED—Several wood wall cabinets for Edison cylinder records, horizontal styles preferred, to hold from 750 to 5,000 records. We can use several sound-proof booths, must be in A-1 shape and reasonable in price. Give size as well as finish in either case. Also disc record cabinets for Edison stock records. Address "Box 546," care The Talking Machine World, 373 Fourth Ave., New York.

WANTED—Saleswoman, records and phonographs, desires position as department head or as manager of branch shop. High reference. Address "Effective," care The Talking Machine World, Republic Building, Chicago, Ill.

WANTED—Knuckle joints used to convert Rex tone arms for playing Victor records. State price. Address "Box 363," Salamanca, N. Y.

SITUATION WANTED—Record expert with twenty years' experience wants position as recorder lateral or vertical. Would like to become associated with concern desiring to manufacture records. Address "Box 547," care The Talking Machine World, 373 Fourth Ave., New York.

EXCEPTIONAL TERRITORY for men handling pianos and have established territory to sell our line of phonographs on commission. American Phonograph Co., 39 Fountain Street, Grand Rapids, Mich.

REPAIRS

All Makes of Talking Machines
Repaired Promptly and Efficiently

TALKING MACHINE REPAIR
AND SALES CORPORATION

ANDREW H. DODIN, President
176 Sixth Avenue New York
TELEPHONE, CHELSEA 8437

EXECUTIVE, accountant and office manager with wide experience in offices of manufacturers of machines and records, is looking for suitable connection. (Draft exempt.) Highest references. Address "Box No. 552," care The Talking Machine World, 373 Fourth Ave., New York.

PURCHASING AGENT, thoroughly experienced in talking machine field will consider proposition September 15. Capable and efficient and can also take charge of phonograph factory or assembling plant. Draft exempt. First-class references. Address "Box M," care The Talking Machine World, 373 Fourth Ave., New York.

POSITION WANTED—Assistant manager of branch of America's largest phonograph supply factory, is open for executive position. Address "Box 548," care The Talking Machine World, 373 Fourth Ave., New York.

REPAIRMAN WANTED—Experienced repairman desired for permanent employment. State age and past experience. Brunswick-Balke-Collender Co., 94 Washington St., Boston, Mass.

POSITION WANTED—City salesman or department manager—by man of twelve years' experience. Best references. State particulars. Address "Box 549," care The Talking Machine World, 373 Fourth Ave., New York.

We have an opening for one or two good salesmen. Salesmen that are willing to work, hustle and bring results. Prefer man who will work on commission. Must come well recommended, send information and references in first letter. Address "Box 550," care The Talking Machine World, 373 Fourth Ave., New York.

FOR SALE—Thriving business, Columbia Agency, with full line of records, also a few pianos. Store is equipped with demonstration booths. Ideal location. Will sell to purchaser at inventory. Address "Box 551," care The Talking Machine World, 373 Fourth Ave., New York.

REPRESENTATIVE exceptionally well known on Pacific Coast, already carrying several representative lines, offers representation to one or two more non-conflicting lines in that territory. Will be glad to consider your proposition. Address "Box 553," care The Talking Machine World, 373 Fourth Ave., New York.

SITUATION WANTED—By expert with eleven years' experience in all branches phonograph line, making, assembling and repairing. Can take complete charge of mechanical end. Had charge of some of large concerns in the manufacturing and assembling from motor to complete machine. Am a good systematizer and organizer. Address "A. U. 1," care The Talking Machine World, 209 South State St., Chicago, Ill.

SITUATION WANTED—Who can use a high-class manager, either wholesale or retail, capable of taking exclusive charge and producing results? Have had over ten years' experience, willing to locate anywhere. Address "Box 540," care The Talking Machine World, 373 Fourth Ave., New York.

SITUATION WANTED—Salesman (35) acquainted with every angle of the business. Phonographs, records and sundries. Vigorous result getter on road. Drawing account against commission. Address "Phonographs," 22 East 125th St., New York.

POSITION WANTED—Talking machine salesman, five years' experience. Inside position large city preferred. Familiar with all well known machines. References. Address "A. P. 2," Talking Machine World, 209 So. State St., Chicago, Ill.

WANTED—Thoroughly experienced, aggressive Edison, Victor and Columbia manager is open to manage department. Any location. Success guaranteed. Address "J. L. 8," care The Talking Machine World, 209 South State St., Chicago, Ill.

POSITION WANTED—By wholesale phonograph and piano salesman. Open for position to travel east of Chicago. Held last position 2½ years. Phonograph position preferred. Best of references. Address "Box 536," care The Talking Machine World, 373 Fourth Ave., New York.

POSITION WANTED—Salesman or tuner. Highest references. Capable branch house management or piano, talking machine or musical instrument department. Age 42. Salary and commission. Address "Box 537," care The Talking Machine World, 373 Fourth Avenue, New York.

SITUATION WANTED—By an experienced talking machine man, experience of ten years, Europe and United States. Has been doing work for some large manufacturing concern—live salesman; mechanic. Address Universal Talking Machine Co., 5021 Baltimore Ave., Philadelphia, Pa.

INCORPORATED

The Palace Talking Machine Shop, Inc., New York, has been chartered with capital stock of \$25,000 by S. Birns, A. Bendersky and M. Glossman.

The Lorophone talking machine, made by the Lorimer-Hicks Mfg. Co., of Troy, O., is represented in Washington, D. C., by the Helbig Piano Co., Inc.

MAIN SPRINGS

AND PHONOGRAPH PARTS

Steel Needles (100 in envelope), per 1,000 needles 0.65
Sapphires, for Pathé or Edison, each..... 0.25
Genuine Diamonds for Edison Disc, each..... 1.75

MAIN SPRINGS

For Edison Motors, size 1½", each \$1.75
For Columbia Motors, size 1"x0.28x10", each... 0.60
For Columbia Motors, size ¾"x0.23x9½", each. 0.30
For Columbia Motors, size ¾"x0.22x8½", each.. 0.24
For Mermod Motors, size ¾"x0.22x8", each..... 0.35

GOVERNOR SPRINGS

For Columbia Motors, bent, per 100..... 1.50
For Victor Motors, per 100..... 1.50

THUMB SCREWS FOR STYLUS BARS

For Victor Soundboxes, per 100..... 1.50
For Columbia Soundboxes, per 100..... 1.50

MICA DIAPHRAGMS

For Victor Soundboxes, each..... 0.15
For Columbia Soundboxes, each..... 0.25
For all standard Soundboxes, each..... 0.22

NEEDLE CUPS

Needle Cups, nickel plated, per 100..... 2.00
Covers to nickel cups for used needles, per 100.. 1.25
Green Felt for 10" turn-tables, each..... 0.10
Green Felt for 12" turn-tables, each..... 0.15

FAVORITE PHONOGRAPH ACCESSORY CO.

1491 DeKalb Avenue Brooklyn, N. Y.

FOR SALE

50,000 double face 10 in. and 12 in. records, well assorted.

300 table phonographs with covers, 15 x 17 x 20 universal soundbox.

Suitable for special sale or regular line.
For particulars address P. E. Haessler, 56 Bigelow St., Newark, N. J.

FOR SALE

A balance of a large stock 5,000 Victor, Columbia and Emerson records; 500 one-inch main springs at 28c; 500 micas for Columbia sound boxes at 20c; 10 and 12 inch turn tables, 10c and 20c. Complete large covered machines 18x20 at \$6.50, 14 inches high.

A large assortment of motors, parts, etc., for Victor and Columbia machines to be disposed of at any price at

144 LUDLOW STREET, NEW YORK
Tel. 6668 Orchard Near Rivington St.

WANTED

Records in all Languages, Talking Machines and Accessories. Spot Cash Paid

Victoria Record Exchange, 2104 Third Ave.
Phone 7848 Harlem NEW YORK CITY

UNICO BOOTHS WANTED

WANTED—To purchase four Unico booths 6x9. What have you? Price must be low—good condition. F. O. B. your depot.

BOX 605 MERIDIAN, MISS.

FOR SALE

Phonograph Records, lateral cut, 10 and 12 inch, standard make, a fine assortment of vocal and instrumental selections.

I. DECKINGER

3064 Albany-Crescent Ave. New York

SITUATION WANTED—Salesman, live wire, special experience in foreign records. Knows the business from A to Z. Address. Universal Talking Machine Co., 5021 Baltimore Ave., Philadelphia, Pa.

DEPARTMENT MANAGER—Eight years' experience Victor, Columbia and Vocalion. Now employed. Will be open for change September 1. Address "A. U. 7," care The Talking Machine World, 209 South State St., Chicago, Ill.

NEEDLES

WE MANUFACTURE

Diamond needles for Edison
Sapphire needles for Edison
Sapphire needles for Pathé
in stock ready for delivery

MERMOD & CO., 505 5th Ave., N. Y.

FROM OUR EUROPEAN HEADQUARTERS

2 GRESHAM BUILDING, BASINGHALL STREET E. C., LONDON, W. LIONEL STURDY, MANAGER.

Business Prospects Despite War Conditions Are Quite Fair—Retailers, of Course, Are Suffering From Stock Shortage—The Gramophone Association Is Doing Good Work—The Bearing of the Luxury Tax on Gramophones—The Influence of Music on the War—Pathé Frères Issue Interesting Bulletin—Other Record Companies Issue Some Striking Numbers—Introducing the "Academy" Gramophone—News Budget of the Month in Detail

LONDON, E. C., ENG., September 1.—With the advent of September, traders rightly begin to look forward to what is regarded as the commencement of the season. During the war period, the line of demarcation between the busy season and the slack time, as measured in pre-war commercial periods, is somewhat less apparent, owing perhaps to the consistently large trade throughout the whole year with the military and naval forces. Our soldiers and sailors recognize no particular period as the gramophone season, for to them music is a recreation necessity all the time. Inland dealers feel the beneficent reflex of this by continuous all-the-year-round sales of gramophones and records. A great number of parcels are dispatched to the Front every day by relatives of soldiers and sailors. In the coast towns live dealers naturally experience an excellent trade, especially from ports of departure where last-minute sales are the rule. It may not be generally known that whenever an officer gets a pass for Blighty, it is a breach of an unwritten law of etiquette to return without half-a-dozen or more records of the latest songs or items from leading London plays. That accounts for quite a nice trade, and it is a byword that the fortunate West End London dealers

enjoy many sales of a substantial nature from this source. Be that as it may, there is nevertheless a speeding up of sales among the general public. The clock goes back at the end of September, summer time is o'er, and the long, dark evenings then set in with a suddenness of complete change. The average gramophonist turns to his instrument with a reawakened interest, looks up the dealer for a few new records, and gradually resumes the pleasurable habit of regular purchases. Whatever the delight of open-air music, a very small per cent. indulge themselves during the summer months. Very seldom is the gramophone taken out in the garden, and as during the fine weather the user is very seldom indoors, it is certain the instrument in too many instances is purely a winter feature of entertainment. Hence, the sales season, as we know it, is for the masses mainly when the long dark evenings prevail.

Of the business prospect much could be written. The times are peculiar; there are many precedents to build upon, and after a careful survey of all the circumstances in relation to past and present conditions, I am assured that there is no prospect of undue depression for the coming season's trade. Owing to war difficulties, too apparent to mention, but which may be regarded particularly in relation to the scarcity of labor, I am personally of opinion that we shall not experience anything in the nature of a boom. I do not know that it is, or could be, expected. There can be no doubt, however, that the manufacturers will have all their work cut out to keep pace with the almost certain big demand for records. The supply will be solely measured by the labor situation, and the factory that can run a night shift must regard itself

as very fortunate. That it may be done is conceivably possible for short periods, but the cost must be out of all proportion to the sales-price. There are in fact so many things to consider that it would be futile to embark upon any very definite forecast of the likely action of manufacturers. If they can supply the goods, the demand can be left to the dealers' activity.

On the instrument side, matters are not so bright. Outside an insignificant quantity of British-made motors, all the mechanism is imported. There are more restrictions on imports this year than last, so that this season sales must suffer proportionately. The production of gramophones at the present time is, one might truly say, entirely governed by the motor situation, as all other parts are by no means so difficult to obtain. If there be an impression that the machine situation is fairly easy, it must be due to the fact that during the past few weeks quantities of motors have been held in reserve for the season's trade. The best possible use will be made of them during the busy time when they will certainly go a long way to ease the situation.

Matters are somewhat difficult among the retailers. What with the loss of valuable employes and always the prospect of being "called," the average dealer of military age is in a quandary. Not feeling free to put ideas and business plans into effect, his interest slackens, and the business suffers accordingly. Whether or not this state of things will seriously affect the trade time alone will determine, though in any case it cannot make for stability.

The Gramophone Association at Work

To follow all the activities of our new associa-

(Continued on page 104)



"His Master's Voice"

Copyright

'His Master's Voice'

—the trade-mark that is recognized throughout the world as the

HALL-MARK OF QUALITY

Branches

DENMARK: Skandinavisk Grammophon-Aktieselskab, Frlhavnen, Copenhagen.

FRANCE: Cle. Française du Gramophone, 115 Boulevard Richard Lenolr, Place de la République, Paris.

SPAIN: Compañía del Gramofono, 56-58 Balmes, Barcelona.

SWEDEN: Skandinaviska Grammophon-Aktiebolaget, Drottning Gatan No. 47, Stockholm.

RUSSIA: The Gramophone Co., Ltd., 45, Nevsky Prospect, Petrograd (Petersburg); No. 1 Solyanka, Solyanol Dvor, Moscow; 9, Golovinsky Prospect, Tiflis; Nowy-Swiat 30, Warsaw; 33, Alexandrowskaya Ulitsa, Riga; 11 Michalovskaya Ulitsa, Baku.

INDIA: The Gramophone Co., Ltd., 139, Bal-laghatta Road, Calcutta; 7, Bell Lane, Fort, Bombay.

Agencies

AUSTRALIA: S. Hoffnung & Co., Ltd., Sole Concessionaries of The Gramophone Company, Limited, 163, Pitt Street, Sydney.

NEW ZEALAND: Gramophonum, Ltd., 118-120 Victoria Street, Wellington.

SOUTH AFRICA: Darter & Sons, Post Box 174, Capetown; Mackay Bros., Post Box 251, Johannesburg; Mackay Bros. & McMabon, Post Box 419, Durban; Ivan H. Haarburger, Post Box 105, Bloemfontein; Franz Moeller, Post Box 108, East London; B. J. Ewins & Co., Post Box 86, Queens-town; Handel House, Kimberley; Laurence & Cope, Post Box 132, Buluwayo; The Argus Co., Salisbury.

EAST AFRICA: Bayley & Co., Lourenzo Marques.

HOLLAND: American Import Co., 22a, Amsterd Veerkade, The Hague.

ITALY: A. Bossi & Co., Via Orefici 2, Milan.

EGYPT (Also for the Soudan, Greece and the Ottoman Empire): K. Fr. Vogel, Post Box 414, Alexandria.

Great Britain :

The Gramophone Company, Ltd.
HAYES - MIDDLESEX - ENGLAND

This intensely human picture stands for all that is best in music

—it is the "His Master's Voice" trade-mark, and it brings to you, no matter where you are, the very best music of every kind, sung and played by the world's greatest artists—the greatest singers, pianists, violinists, orchestras and bands—all enshrined in the unequalled "His Master's Voice" records

FROM OUR LONDON HEADQUARTERS—(Continued from page 103)

tion is a real pleasure and a matter of valuable interest to all members, of whom the total is now well over a hundred. The firms enrolled comprise the cream of the trade, each in its way out to exert a powerful influence for the common good. Much useful work has already been done, and in connection therewith we are convinced that the right men are at the helm to carry through successfully that to which they commit themselves after a full and very thorough discussion in committee. One instance of the vigor with which the association is being conducted is the preparation of a petition to the Prime Minister urging "the absolute prohibition of import from enemy countries for a period of five years after the war of any musical instrument goods and component parts thereof, including gramophones, mouth organs and accessories."

The question of economic treatment will undoubtedly be a matter for the peace conference, and will necessarily represent an important subject over which our present enemies will attempt to bargain. In this regard, therefore, and as a mirror of public opinion, the petition makes a timely appearance. The pledge of the trade must carry a big influence in official quarters, and it should be made known without delay that we will brook never again the underhanded commercial methods of our present enemies. In Russia to-day the Germans are selling British goods under well-known British names, copied and of course "made in Germany." They dare not attempt a market for goods in their own name, so, from pre-war British samples, the trickery of spurious manufacture is adopted.

The first Trade Bulletin issued by the association has made its appearance. It is decidedly interesting throughout, the following notes being typical examples of its valuable contents:

British Music Trades' Industry Committee.—A concession of transatlantic tonnage was received from the Board of Trade Department of Import Restrictions, and this is allotted by the committee to the trade, allocation being made on a percentage of 1915 imports. The committee also hold a grant up to July 11, 1919, of Swiss tonnage for distribution under specified terms of reference.

Gramophone needles.—A special monthly grant of metal has been received from the Ministry of Munitions for needle wire.

Main springs.—The committee has also obtained a monthly allowance of steel for the replacement of these parts.

Metals.—After negotiations extending over many months the committee received from the Ministry of Munitions a grant of metals for the industry. This grant is distributed through an independent rationing authority.

French Ministerial Decision.—June 4, 1918, Article 11. By remission of the regulations of the decree of December 21, 1914, and subsequent decrees, products and articles hereinafter mentioned may be exported or re-exported without

special authorization when destined to be forwarded to England, Belgium, Italy, or to extra-European countries: Cylinders, discs, and rolls for gramophones and phonographs.

The Luxury Tax and Gramophones

It is understood that the Luxury Tax Committee has reached an agreement as to its final report for presentation to the Cabinet. The proposed schedule of articles which it is recommended should be taxed has been carefully compiled under two categories, i. e., articles subject to taxation whatever the price, and articles which are considered luxuries only when they exceed a given figure. Musical instruments come within the first named class, the duty rate suggested being 2d. in the shilling. Of the second list it has been left to the government to decide whether the tax shall operate on the whole price of the article or begin only when the luxury limit is reached. A majority of the committee favor the former plan, though a very substantial minority consider the tax should only be imposed on the luxury margin.

The whole case will be thoroughly threshed out in Parliament when it reopens in October. There is very strong opposition to the principle of the proposed bill; it is a kind of legislation which is unfavorably regarded by the people, and in more than one quarter an impression prevails that the proposals will have to be so drastically amended that the cabinet may even deem it advisable to drop the measure altogether. Whatever be the outcome, the bill cannot pass through all its parliamentary stages and become law much before the end of November, and should it pass, may not in the circumstances become operative until the New Year.

There is no suggestion that it is legislation designed purely for the suppression of trades which happen to manufacture articles known as luxuries. This is certainly not the Government's intention. It is simply a war measure to assist in meeting the cost of national expenditure. The committee has decided that musical instruments bought by the people are luxuries, so that further argument on that ground is more or less useless, even were one so inclined to indulge therein. Accepting the fact, it just means that two shilling records will probably cost the buyer sixpence extra. It may or may not affect sales—personally, I do not think it will beyond a very short period, but given that it does, a little propaganda work would go a long way to minimize the first effects of the tax. Put in the light that a buyer is indulging in something that he can reasonably do without; tell him the extra sixpence is for buying aeroplanes, tanks, or guns, in order to keep inviolate his country; to protect his home, his wife and little ones from the horrors suffered by thousands of Belgian, French, and other nationalities—sure that it with many others would pass like a flash of lightning.

The proposal has been made in these columns that the Government should see fit to exempt

REX GRAMOPHONE CO.

are making a Specialty of

EXPORT

in

Horn, Hornless & Portable Disc Machines

REX GRAMOPHONE CO. 2 Elizabeth Place
Rivington Street, LONDON, E. C. 2

Cable Address "Lyrecodisc, London"

Enquiries Solicited

from taxation records and gramophones where it can be clearly shown that they are for the sole use of H. M. forces.

The Luxury Tax Committee's Report

Since writing the foregoing the report of the Select Committee, appointed to consider what articles ought to be classed as luxuries, has been published. I am precluded from making a detailed examination of the committee's findings, owing to the need for almost immediate despatch to catch the next mail, but in my next report the matter can be more fully dealt with. The chief points of interest are set out in the following paragraphs:

The schedule of the proposed taxable articles has been based upon the French lists which classify articles of absolute luxury under twenty-six heads, and articles with a price limit under seventy-seven heads.

Pianos, other than upright, player-pianos, gramophones, phonographs and records, musical boxes, and perforated music rolls, it is suggested, should be taxed whatever their price, with the exception of upright pianos below a £40 limit, harmoniums below £20, violins below £7, and all other musical instruments and accessories not specified (as above) below £1. Whether the tax will be levied upon the whole cost of the latter schedule, or only upon such amounts above the price-limit given, has yet to be settled when the Bill is dealt with in Parliament.

Exemption from the tax is suggested for musical instruments and accessories purchased by, and for, the use of students of music at any recognized college of music, or similar institution. The committee are of opinion that in such cases exemption should be confined to those who are studying music systematically, and not merely as amateurs, for amusement sake.

It is a matter for congratulation that the committee has accepted the suggestion put forth in these columns, and submitted also by the officials of The New Gramophone Association, that all musical instruments and accessories purchased by properly authorized bodies solely for the entertainment of, or use by, the forces of the Crown, shall be totally exempt from the tax.

As to the method of its collection considerable diversity of opinion exists, some favoring the use of stamps when the actual sale is made; while others put forward the alternative suggestion of opening an account with the treasury, under bond to make periodical settlements. All such proposals emanating from outside trade

EDISON BELL

WINNER
TRADE MARK
GRAMOPHONE RECORDS

CABLE
"PHONOKINO.
LONDON"

ARE THE GREATEST VALUE FOR MONEY PRODUCED IN GREAT BRITAIN

TEN INCH

DOUBLE SIDED

NEEDLE CUT

PLAY ON ALL GRAMOPHONES

Catalogue contains 4000 Titles by the Premier Artistes, Instrumentalists, Orchestras and Bands of the British Empire

DEALERS PREPARED TO DO BUSINESS ARE INVITED TO COMMUNICATE WITH

Proprietors and Manufacturers, **J. E. HOUGH, Ltd., 62 Glengall Road, London, S. E. 15, England**

FROM OUR LONDON HEADQUARTERS—(Continued from page 104)

committees have been embodied in the report in the form of an appendix.

A Fine Budget of "Popular" Records

The Sound Recording Co., makers of the "Popular" record, report the satisfactory news of an early opening of the home season's trade, retail and wholesale orders having already necessitated a considerable speeding-up of output. The company have been busily engaged during the past week or so in recording a representative number of the leading song hits, many of which by their present popularity will doubtless reach the standard required for presentation at the Pantomimes.

To oversea buyers the opportunity presents itself of being right up-to-date by the inclusion in their stock of these forthcoming Pantomime favorites, and to this end the time to investigate is now. Lists and trading terms may be obtained upon direct application to the company.

The Pathé Frères Bulletin

The American custom of issuing what is described here as a house organ has not been very much developed among British firms. The idea was certainly very much on the move before the war, but since, owing largely to the scarcity of paper and labor, it has fallen off very considerably. Nevertheless, Messrs. Pathé Frères have just embarked upon the issue of a chatty little sheet which goes under the title of The Pathé Frères Bulletin. Unlike most house organs that appeal directly to the firm's dealers, this one is more of a private character, particular to the Pathé staff. It contains many humorous notes, is brightly conceived, and will doubtless be much appreciated. We wish it all the success it so well merits.

Whilst on the subject, it is interesting to note that this firm has recently issued some splendidly recorded band and orchestral records of the leading plays, as, for instance, "Bubbly," "Arlette," "The Boy," "Yes, Uncle," "Pamela," "The Lilac Domino," "The Maid of the Mountains," and others. These records mark a distinct advance upon previous instrumental recordings; indeed, they may be characterized as at least the equal to any similar output, being in every way as perfect in balance or ensemble, and tonal quality, with the right degree of volume, as the most captious critic could wish for.

By the way, I am glad to learn that Mr. Beckett, the genial manager of the company, who has been very seriously ill with double pneumonia and its attendant complications, is now well on the road to convalescence. By the time these lines appear it is hoped he will again be in harness.

The "Academy" Gramophone Announced

Described as a new type of musical instrument, the "Academy" gramophone makes its bow to the Irish public through the columns of the Belfast and other newspapers. Its sponsor is Thomas Edens Osborne, who usually has something new to put before the great Irish

music-loving public. Put up in oak and mahogany cabinets, the Academy is of the hornless type, is equipped with cover to conceal the motor, which is of double-spring power, silent and true-running. The prices are based upon a competitive standard, and the Academy is a good selling line. Belfast trade is fairly brisk, there being a notable increase in sales as the season draws nigh.

Foreign Patent "Payments" Disallowed

It is announced that the Board of Trade have revoked the general licenses of December 7, 1915, and September 5, 1917, under which, subject to certain conditions, the payment was permitted of fees, etc., due in enemy countries in respect of the grant, registration, or renewal of patents, designs, and trade marks, and also the payment in the Dominions and Allied territory on behalf of enemies of similar fees, etc. All such payments are consequently prohibited in future.

"His Master's Voice" New Instrument List

This company's dealers are in receipt of a handy little folder containing a complete description of the season's "His Master's Voice" models, comprising horn, hornless, table and cabinet grand instruments.

All in the Family!

An amusing recording experience is given currency in "The Voice," published by the Gramophone Co., Ltd.: "A short while ago the recording department had an appointment to try the voice of an Italian artist. The day of the appointment arrived, and an artist came at the time arranged. His attempt at singing, however, was so mediocre, and even absurd—when we were expecting a fairly good Italian singer—that the artist was questioned as to why he had come. He replied that the appointment was not really for himself, but for his brother; his brother was unfortunately unable to come and therefore had sent him instead! The artist for whom the appointment was originally intended again wrote for an audition, but we decided not to grant him this request, as we feared that this time he might send his father."

The Zonophone No. 3 List

In connection with the issue of the latest program of records, this company aptly reminds dealers that there is no necessity to ration customers for Zonophone records providing a sufficient quantity of each title is ordered. Certainly there is no lack of new issues from which to choose, as the list under mention itemizes no less than sixteen double-sided ten-inch records—thirty-two titles, all up to date, and for which the cream of vocal and instrumental talent has been commandeered. It is really a wonderful program, both in choice of selections, which are of a varied nature, and artists.

How It Will Be Done—a Warning!

A Milan newspaper has gleaned information of a confidential German circular which has been prepared in the interests of post-war business. The following extract is tantamount to a clear

Soundboxes

IF you are after a genuine offer of soundboxes, you'll do well to communicate with us immediately. We have tens of thousands of perfect soundboxes, fitted with the best quality mica. Confidently recommended for cheaper machines, absolutely reliable and give excellent reproduction. Price to clear \$50 per gross, F. O. B. London.

Orders for less than gross lots not accepted

Wire "Knotaslepe, London".

W. H. Reynolds (1915) Ltd.
45, City Road, London, E. C.

Write for new illustrated Complete Catalogue

recognition on the part of our present enemies that they will be up against a big proposition when, after the war, they hope to re-establish commercial relationship in Allied and neutral markets. Forewarned is forearmed, and we shall surely be fully alive to the methods they propose to adopt. How they proposed to resume export trade is disclosed by the extract in question: "It would be wise for all German houses having large interests abroad to employ in foreign countries representatives or travelers who may be able to successfully pass themselves off as French, or British, or American. We must undoubtedly be prepared to face a considerable amount of personal prejudice."

Entertaining Items on the Winner List

A varied and carefully chosen program of titles has been issued for July-August by the Winner Record Company. Vocal numbers predominate, but a representative sprinkling of band, orchestral, and other instrumental selections are contributed by such eminent talent as H. M. Irish Guard Band, the Royal Court Orchestra, and the not unattractive Hawaiian melodies by Lady Chetwynd and Lavaun. The great Revue "star," Lee White, tops the vocal bill with record 3232, "I've Got the Sweetest Girl in Maryland" and "The Island of By-and-By," two catchy and tuneful ditties which are very popular this side.

Two good songs are contributed by Norman Griffin, a leading comedian in the popular "Yes, Uncle" production. Ernest Rutterford, exclusive to Winners, presents some wonderfully fine concertina solos, and "hits" of the day are down to the credit of the Elliots and the Two Bobs;

(Continued on page 106)

GUARDSMAN RECORDS

REGISTERED

10 inch and 12 inch Lateral Cut

We can ship you immediately, any quantity of Records:

BANDS ORCHESTRAS INSTRUMENTAL SOLOS VOCAL

WIDE SELECTION OF CLASSICAL AND POPULAR TITLES

The Latest American and British works are promptly recorded by the best artists of the day.

Get a trial lot at once (your regular orders will follow) and secure yourself for the coming season's trade.

Apply for Lists and Prices to INVICTA RECORD COMPANY, Ltd.

Cables: Duarrab, London

1 New Inn Yard, London, E. C., England



TRADE MARK



THE "POPULAR" RECORDS

Double-Sided
Superb Needle Cut
"Lateral"



LONDON'S LEADING VALUE!!!

"OUR POINTS"
SET OUT BELOW

Have Attracted Keen Overseas Houses

from SCANDINAVIA to PATAGONIA
AND THE PRINCIPAL
EAST and WEST MARKETS of the WORLD

REMEMBER  You Can Have CLOSE QUOTATIONS

For 5,000 Lots and up Your Selection or a Sample
1,000, 75% "Bands and Orchestrals."

Address: **SOUND RECORDING CO., Ltd.** CABLES "Grammavox"
EXPORT DEPT., 18-19 Swallow Street London
Piccadilly, London, England QUOTATIONS CABLED FREE

POINTS

- ➔ Repertoire Apprx 2,000 Titles
- ➔ Superb Selection, Bands and Orchestrals
- ➔ Lightning Shipments under Government Export License
- ➔ Packing by Experts
- ➔ Rock Quotations "Always"
- ➔ F. O. B. London
- ➔ We attend to all Insurances "if Requested" to Buyers A/c
- ➔ Our Shipping Services, this Side FREE

FROM OUR LONDON HEADQUARTERS—(Continued from page 105)

also Winner exclusives. The cream of the songs and musical items from two recent London productions, "Yes, Uncle" and "Bubbly," are splendidly recorded by the Royal Court Orchestra on records 3234 and 3238. The list enumerates many other first-class records of high merit. Oversea traders are invited to communicate with the Winner Record Co., London, for particulars of trading, etc.

"The Lilac Domino" Boom

The success of the Columbia series of "Lilac Domino" records by the original artists has been so phenomenal that one is tempted to wonder what might have been the result if some enterprising company had recorded the original performance of the Gilbert and Sullivan Savoy operas with the same lavish care and enterprise as the Columbia Co. have shown in "The Lilac Domino." But in those days the gramophone was unknown. The analogy, however, is a very fair one, for very few such genuinely musical works as "The Lilac Domino" have been heard since the tuneful days of the Savoy operas.

Provincial Workers' Preference for Band Music

Few people in the South of England are aware of the hold exercised by brass band music upon the people in the north, where almost every factory, mill or colliery maintains a brass band recruited from among the employes themselves.

In pre-war times large sums of money were spent in providing prizes and trophies for contests, and the keenest competition was rife year by year to decide which of the many bands could claim pre-eminence. A unique achievement was that of the Wingates Band, the members carrying off in two successive years the Crystal Palace Thousand Guineas National Trophy and the Belle Vue Champion Challenge Cup. There are some thirty selections by Wingates Band now available on Regal records and they are generally conceded to be most successful and faithful examples of brass band recording.

"His Master's Voice" Notes

It is reported in "The Voice" that on one day alone during the recent epidemic of influenza over a thousand of the company's employes were absent from work.

A new idea for local publicity is disclosed by the announcement that a very effective set of colored lantern slides has been prepared by the company and will be sent upon application to their dealers. A profitable means of advertising in local music halls and picture palaces!

Much interest and pleasure has been caused by the news that Miss Olga Haley, whose brilliant career since her debut two seasons ago has brought her into the front rank, is now under a long and exclusive contract to record her golden voice only on "His Master's Voice" records. The company will publish her first records this month, September.

Steel Plate for Parts of Gramophones

A provincial firm has submitted samples of steel plates it is in a position to supply without an official permit certificate, it not being required for war munitions work. It can be rolled to any desired gauge, and can be supplied in sizes from 3 to 18 inches in width; 4 to 6 feet in length. This plate would be useful for turntables, gear wheels, motor plates, spring box plates, and other light pressings. Those inter-

ested should write the London office of this journal, when their letters will be forwarded to the right quarter.

Columbia Descriptive Records of Military Life

A new lease of life has been given to a very excellent series of Columbia records through the new Military Service Act. We refer to those three records "On Active Service" which in six sketches takes the hearer in company with two typical soldiers through scenes of army life. In light vein they deal respectively with incidents of Leaving for the Front, In the Trenches, The Night Attack, The Big Push, "For Valour," and Back Home in Blighty. Their drama and comedy are so well blended as to give a very accurate series of snapshots, as it were, of the life of a man with the colors, and have been abundantly popular in presenting active service scenes to those at home. As a serial story on records, the set is a complete success, and it is winning wide favor.

Rationing of Timber

By the Timber Order dated July 16, the Board of Trade have prepared for the introduction of a rationing scheme of imported soft wood timber which will commence on July 22. A schedule of maximum prices for imported timber will be issued, but will not apply to existing stocks, which will still be subject to the previous regulations as to price. Stocks which under previous regulations may not be sold at prices above those ruling at January 31, 1917, are to be notified to the Controller of Timber Supplies for his decision as to the price at which they may be sold. The permit system is extended to home-grown converted timber on lines somewhat similar to those which have for over a year applied to imported soft wood. Forms of application for permits and full particulars may be had on application to the Controller of Timber Supplies, Branch 2, at 80 Newman street, Oxford street, London, W. I.

Genuine Period Styles

Authentic adaptations of Adam, Louis XVI, Sheraton and Queen Anne periods, harmonizing perfectly with the styles whose names they bear, are a feature of the case work on the Marvelous

MAGNOLA "Built by Tone Specialists"



Watching the Music Come Out

Give us the Opportunity to tell you more about this and other sales-making features of MAGNOLA construction, by sending us your name and address.

We have a handsome catalog, illustrated in colors, that tells Magnola's story—and is yours for the asking.

MAGNOLA TALKING MACHINE COMPANY

OTTO SCHULZ, President

General Offices 711 MILWAUKEE AVENUE CHICAGO
Southern Wholesale Branch 1530 CANDLER BLDG. ATLANTA, GA.

TO URGE WORLD TRADE LAW

Beaumont Alexander Will Confer With Manufacturers Abroad

Beaumont Alexander, president of the Allied Industries Corporation, will visit European countries soon to discuss with British and French manufacturers and merchants the possibility and feasibility of enacting in all allied and neutral countries what may be called a "Country of Origin Law." Such a law would require that all goods imported into the countries having it in force be stamped with the land of their origin, as, for instance, "made in the United States of America." If the goods are made in one country with capital coming from another, Mr. Alexander would have the goods stamped in this fashion: "Made in Sweden with U. S. A. capital," or "made in Switzerland with German capital." Or, to cover another case, he would have the goods stamped: "Made in Holland with 75 per cent.

Dutch capital and 25 per cent. German capital."

Mr. Alexander has considered the need of some such law for a long time.

SOME INTERESTING TESTIMONY

The Pathé Frères Phonograph Co., Brooklyn, N. Y., recently sent out a letter to Pathé dealers stating as follows:

"In a recent suit of the American Graphophone Co. (Columbia Graphophone Co.) against the Emerson Phonograph Co., an interesting piece of testimony relative to the superiority of Pathé records was given by Professor Frank L. O. Wadsworth, appearing as expert for the Columbia Co., as follows: 'Pathé records were the best samples of recording and music on the market, and in his opinion excelled everything else in quality and that he could not testify conscientiously otherwise, although he could not expect in any way to profit by this testimony.'"

LATEST PATENTS RELATING TO TALKING MACHINES AND RECORDS

WASHINGTON, D. C., September 8.—TONE ARM.—Zena Ecklebarger, Goshen, Ind. Patent No. 1,269,266.

The present invention pertains to reproducers for use in sound-reproducing machines and more particularly to the tone arm of reproducers and means for moving the same.

In the accompanying drawings:

Figure 1 is a side elevation of a tone arm embodying the present invention. Fig. 2 is a detail vertical section of the same. Fig. 3 is a cross-section on line 3—3 of Figs. 1 and 2. Fig.

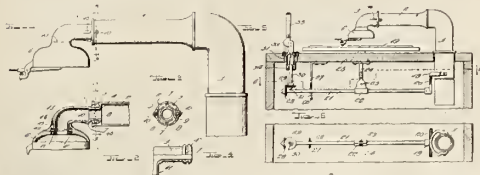

4 is a detail view of the arm section 5. Fig. 5 shows the arm and means for moving the same. Fig. 6 is a section on line 6—6 of Fig. 5.

TALKING MACHINE.—Harry T. Kingsbury and Edward J. Kingsbury, Keene, N. H. Patent No. 1,269,089.

This invention relates to improvements in talking machines. One object is to provide a miniature talking machine in which the horn is supported by the sound box and in which the needle holder and stylus can be readily removed and also providing the pivot of the reproducer arm as the stem for winding the spring motor.

Figure 1 is a perspective view of the improved talking machines; Fig. 2 is a vertical transverse sectional view of Fig. 1; Fig. 3 is a top plan view of Fig. 1 showing the motor and other interior working parts in dotted lines. Fig. 4 is an enlarged side elevation of the attaching means for the needle holder and stylus; Fig. 5 is an enlarged sectional view of the securing means between the base and the motor housing; Fig. 6 is a perspective view of the governor control lever; Fig. 7 is a perspective view of the

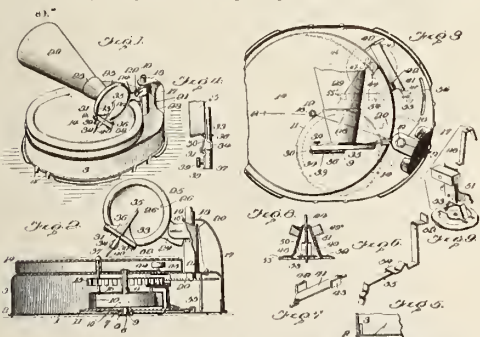

stop mechanism for the rotatable record supporting disc or table; Fig. 8 is a vertical sectional view of the governor; and Fig. 9 is a perspective view of the governor showing the several parts in their disassembled relation.

SOUND RECORD.—John Fletcher, Douglaston, N. Y., assignor to Operaphone Mfg. Corp., New York. Patent No. 1,269,696.

It is well known that the sound records, or talking machine records, now in general use, are divided into two types or classes which are known respectively as the "hill and dale" or vertically undulatory type and the "zig zag" or laterally undulatory type. Records of the "hill and dale" type are usually provided in each case with an undulatory spiral groove of uneven depth forming "hill and dale" undulations corresponding to sound waves, and records of the "zig zag" type are usually provided in each case with an undulatory spiral groove of substantially uniform depth forming "zig zag" or lateral undulations corresponding to sound waves.

In the usual process of producing commercial records of either the "hill and dale" or the

"zig zag" type, it is customary to first form a master record by cutting in a record blank of wax or other comparatively soft wax-like material a suitable spiral groove by means of a suitable cutting tool or stylus vibrated by and in accordance with sound waves. A matrix or negative is then made from the master record by an electrotyping process and the commercial records are then formed by subjecting normally comparatively hard record material, rendered temporarily plastic by heat, to the action of the matrix under great pressure, and then cooling the record material while under pressure.

It has been suggested that in recording "hill and dale" undulations in a record the actual resistance to the action of the recording stylus varies with the depth of the groove being cut whereas in recording "zig zag" undulations there is no variation in resistance due to variation in depth of cut as the depth of cut is constant.

It has also been suggested that in reproducing sound from a "hill and dale" record the bottom wall of the record groove has to perform not only the function of supporting the weight of the sound box but also the function of vibrating the stylus and diaphragm and consequently is subjected to greater wear and must be considerably broader than the bottom of a "zig zag" record which is smooth and even and has to perform only the function of supporting the sound box.

Moreover, it has been suggested that the use

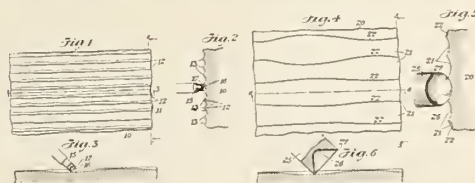

of a wide sound groove in forming a record is considered to be objectionable in that it requires the removal or displacement of a relatively large amount of material from the wax master record, and consequently causes a considerable resistance to the normal action of the recording stylus during the recording process; and that it is also objectionable in that it diminishes the number of words or the amount of sound measured in time which may be recorded upon a given area of record.

Prior to this invention, to avoid a rapid wearing away of undulatory walls of "hill and dale" records it has been customary to provide such records with much broader spiral grooves than are usually provided in records of the "zig zag" type and in an obvious effort to economize space as much as possible the spiral grooves of such "hill and dale" records have been so formed that the successive convolutions of the groove "overlap" or meet in sharp edges.

This invention provides a "hill and dale" record, having an extremely narrow undulatory groove, which may be used successfully in cooperation with an ordinary conically pointed steel needle in reproducing sound, and which has been found to be extremely durable in use and to have practically all of the advantages of a "zig zag" record.

In the accompanying drawings, Figure 1 is a greatly enlarged fragmentary top plan view of a disc sound record constructed in accordance with this invention; Fig. 2 a transverse section of the same on line 2—2 of Fig. 1; Fig. 3 a longitudinal section of the same on line 3—3 of Fig. 1; Fig. 4 a fragmentary top plan view of an old form of "hill and dale" sound record, drawn to substantially the same scale as Fig. 1; Fig. 5 a transverse section on line 5—5 of Fig. 5; and Fig. 6 a longitudinal section on line 6—6 of Fig. 4.

SOUND BOX FOR PHONOGRAPHS.—Charles P. Trundy, Boston, Mass. Patent No. 1,269,659.

The present invention relates to an improvement in sound boxes for phonographs.

The object of the present invention is to reorganize and improve the construction of sound boxes for phonographs in general and especially in the direction of preventing undesirable vibrations from being transmitted from the needle to the tone arm. To the above ends the present invention consists of the sound box.

In the accompanying drawings illustrating the preferred form of the invention, Figure 1 is a front elevation of the sound box; Fig. 2

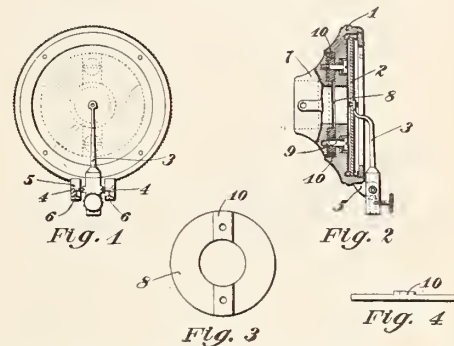

is a sectional elevation, taken at right angles to Fig. 1; Fig. 3 is a plan view of the rubber disc, and Fig. 4 is an elevation of the same.

SOUND BOX.—Charles H. Shaw, Babylon, N. Y., assignor to the Aeolian Co., New York. Patent No. 1,269,965.

The present invention relates to improvements in sound boxes, especially to means for employing a wire stylus in connection therewith and for quickly adjusting it at will to play the phonograph record with any desired degree of loudness or softness. The object and advantages of the invention will be apparent to those skilled in the art from an understanding of the following description in connection with the drawings. In these, Fig. 1 is a face view of a sound box embodying the invention; Fig. 2 is an enlarged detail view of the lower portion of Fig. 1, shown partly in vertical section

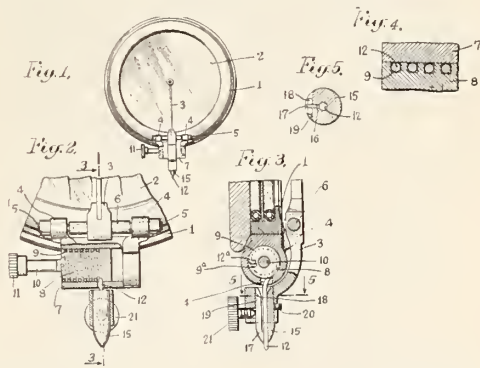

and partly in elevation; Fig. 3 is a sectional view on the line 3—3 in Fig. 2 looking in the direction of the arrows; Fig. 4 is an enlarged fragment of Fig. 2; and Fig. 5 is a horizontal section on the line 5—5 in Fig. 3 looking in the direction of the arrows.

RECORDING AND REPRODUCING PHONOGRAPH.—Ernest A. Ivatts, Paris, France, assignor to Compagnie Generale des Etablissements Pathé Frères, same place. Patent No. 1,269,607.

This invention has for its object a phonographic apparatus more particularly intended for postal correspondence, ordinary letters being replaced by phonographic discs which are recorded and sent through the post to the correspondent who hears upon his apparatus the phonic reproduction of the correspondence recorded on the disc.

In view of the special purpose for which it is more particularly intended, the novel apparatus is constructed in such a manner that it is at once possible by very simple means, either to record for dictating a letter, or to reproduce the sounds recorded for the purpose of reading over that which has been dictated, or to "read" the letter-disc received through the post. This result is obtained without the employment of

LATEST PATENTS RELATING TO TALKING MACHINES AND RECORDS—(Continued from page 107)

any complicated mechanism owing to the fact that no nut and screw mechanism is employed for driving the recording and reproducing diaphragms, a method of driving already known per se being employed; this consists in providing the sound arm carrying the diaphragm with a guiding point which moves in a spiral groove formed upon a guide plate concentric with the disc over which the usual stylus of the recording or reproducing diaphragm is displaced.

According to the invention the apparatus comprises two independent sound arms which respectively carry the recording sound box and the reproducing sound box, these two sound arms being guided by the spiral groove of one

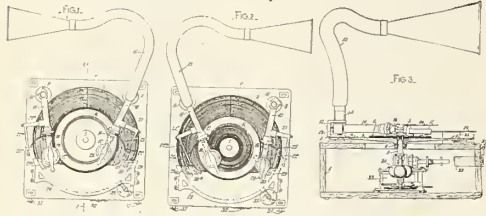

and the same guide plate. This combination of two sound boxes, one for recording and the other for reproducing, with a single guide plate capable of displacing both of them with their sound arms in accordance with an angular translatory movement for producing the record and the reproduction, has great advantages as will be readily understood, because it allows of obtaining a recording and reproducing apparatus which is of exceedingly simple construction and is very compact and in which the number of elements is reduced to the strict minimum.

The novel apparatus is also characterized by the combination with the two sound arms carrying the recording and reproducing sound boxes and the single guide plate the spiral groove of which controls the two sound arms of a special phonic disc constituted by a core of cardboard, paper or analogous material covered on its two faces with a layer of wax or suitable composition for receiving the record. For the purposes of correspondence, this phonic disc has the advantage that it can be transmitted through the post without taking special precautions and without risk of damage so that its employment in combination with the device described above renders it possible to utilize the apparatus under the best conditions for the special object in view, that is to say for correspondence.

Figure 1 is a plan of the apparatus showing the position of the parts during recording. Fig.

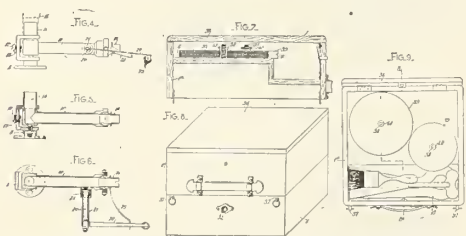

2 shows the position of the parts during reproduction. Fig. 3 is a vertical section on the line A—A in Fig. 1. Fig. 4 is an elevation of a sound arm. Fig. 5 is a vertical section thereof. Fig. 6 is a horizontal section thereof. Fig. 7 is a partial vertical section on the line B—B in Fig. 9. Fig. 8 is a perspective view of the case, containing the complete apparatus in the constructional form illustrated by way of example. Fig. 9 is a plan view with the lid of the apparatus raised.

SOUND MODIFIER FOR TALKING MACHINES.—Pinus Farb, Newark, N. J., assignor to the Sonora Phonograph Corp., New York. Patent No. 1,270,278.

This invention relates to sound modifiers for talking machines, for modifying the sound between the tone arm and the horn to any desired extent.

The object of the invention is to provide a device which will be simple and effective in operation, not likely to get out of order, and will be locked in the desired position.

In the drawings Figure 1 is a top plan view of a talking machine cabinet partly in section, the section being on the line 1—1 of Fig. 2, embodying the invention; Fig. 2 is a side elevation partly in section, the section being taken on

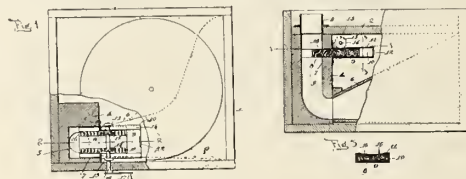

the line 2—2 of Fig. 1; and Fig. 3 is a detail sectional view on the line 3—3 of Fig. 2.

PHONOGRAPH NEEDLE.—Lewis C. Keen and John M. Klevan, Philadelphia, Pa. Patent No. 1,270,526.

This invention relates to an improved phonograph needle, and has for its primary object to provide a double pointed needle, which is of such construction that the harsh, discordant scratching noise or sound incident to the operation of the phonograph with the ordinary commercial needle now in general use will be eliminated.

And it is another object of the invention to provide a double pointed needle of great wear resisting quality, having a central cylindrical enlargement constituting a stop to limit the movement of either end of the needle into the holder on the sound box, and thus prevent possible blunting or other injury to the needle point.

It is a further general object of the invention to provide an article of the above character which will be very serviceable and efficient in practical use, requires no alterations in the con-

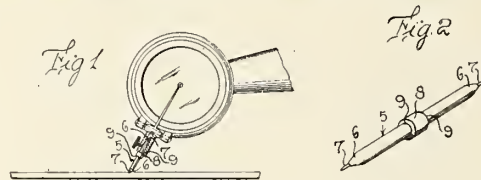

struction of the ordinary needle holder, and can be manufactured in large quantities at relatively small cost.

Figure 1 is a sectional view through the needle holder of a sound box having one of the improved needles secured therein; and Fig. 2 is a perspective view of the needle.

PHONOGRAPH.—George W. Lorimer, Piqua, O. Patent No. 1,270,534.

This invention relates to improvements in sound conducting horns and more particularly to phonograph horns.

The object of the invention is to provide a phonograph horn, the walls of which are under stress of such a character that the tone of the instrument is much improved.

A more specific object is to provide a phonograph horn of non-collapsible material, the wall at one end of which is maintained under constant tension.

In the accompanying drawings is illustrated one embodiment of the invention. Other embodiments, however, may be devised.

Figure 1 is an elevation partly in section of a

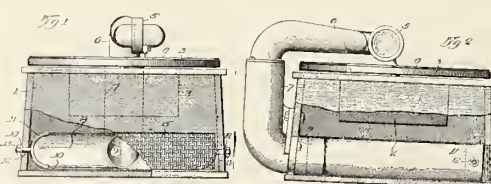

phonograph which will serve to illustrate the improvement. Fig. 2 is a side elevation thereof partly in section.

AUTOMATICALLY-ACTING MULTIPLE-RECORD SUPPORTING TABLE.—Lewis R. Gilbert, New York, assignor to George R. Webb, Baltimore, Md. Patent No. 1,269,175.

This invention relates to tables for supporting sound reproducing records, and more particularly to that type of such tables in which

one table with its record is automatically brought into operation at the time that another table and its record is thrown out of operation. The present invention contemplates a plurality of carrying tables coupled one with the other so that as one record is exhausted its table is brought to a state of rest and simultaneously another record-carrying table is automatically brought into action so that its record may be used for reproducing purposes and while being so used a new record may be placed on the other table, and so on in alternation, and thus making it possible to have practically a continuous reproduction from records without the annoyances incident to temporary cessation of sound reproduction. The present invention in its practical embodiment comprises a plurality of record carrying turntables, each constructed like the other, and one coupled to the other so that automatically one will be brought to a state of rest while the other is put in motion, each having associated with it a grooved drum calibrated to correspond with the grooves of the records and having a trigger co-operating with the drum so that when the record has reached its limit of reproduction the trigger will set parts in operation to stop the table whose record has become exhausted and simultaneously set in motion the other record carrying table whose trigger has been placed in position on its drum for action in manner similar to the trigger and drum of the other table, and so on in alternation from one table to the other. The invention furthermore contemplates the provision of a cushioning device which will absorb the shocks that otherwise might tend to disengage or shift the position of the reproducing needle in relation to the record or the position of engagement of the trigger with the calibrated drum. It furthermore contemplates a variable coupling between the record reproducing mechanism and the projector of a motion picture device so that the travel of the film of the motion picture device may be regulated or controlled to bring it into synchronism with the sound reproducing mechanism should the synchronism between the two devices be temporarily disturbed.

In the accompanying drawings Figure 1 is a plan view of the apparatus, with parts in horizontal section; Fig. 2 is a side elevation, with

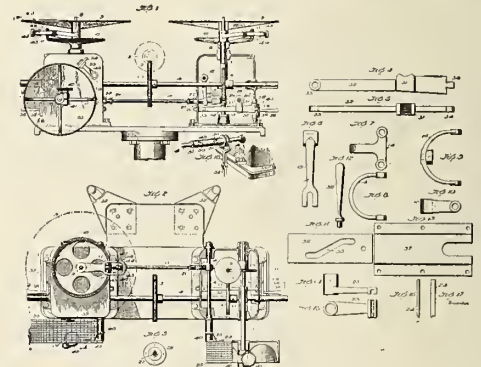

parts in vertical section; Fig. 3 is a cross section through the drum shaft with its worm gear in full lines; Fig. 4 a side view, and Fig. 5 a plan view of the arm carrying the sectional nut for the screw of the drum shaft; Fig. 6 a front view of the rock shaft arm; Fig. 7 a side view, and Fig. 8 a plan view of one of the quill lifting links; Fig. 9 a plan view, and Fig. 10 a side view of the yoke which connects the two links; Fig. 11 a side view of the cam-plate that raises and lowers the sectional nut carrying arm; Fig. 12 a side view of the handle for manipulating the cam-plate; Fig. 13 a side view of the cover for the cam-plate; Fig. 14 a plan view, and Fig. 15 a side view of the trigger; Fig. 16 an edge view and Fig. 17 a view at right angles thereto, of the trigger needle; Fig. 18 a perspective of a portion of the casing of one table with the cam sleeve coupling two sections of the projector shaft with means for shifting the sleeve to accelerate or retard the film of the projector.

RECORD BULLETINS FOR OCTOBER, 1918

VICTOR TALKING MACHINE CO.

POPULAR SONGS

- 18492 Good-bye Alexander, Good-bye Honey Boy, Marion Harris
When Uncle Joe Steps Into France, Collins and Harlan
18493 When You Sang "Hush-a-bye Baby" to Me, Sterling Trio
Mammy's Chocolate Soldier, Marion Harris
18494 For Your Boy and My Boy, Peerless Quartet
When You Come Back, Raymond Dixon and Orpheus Quartet
18495 The Yanks Are At It Again, American Quartet
When I Get Back to My American Blihty, Arthur Fields
18496 I'm Always Chasing Rainbows, Charles Harrison
I Miss That Mississippi Miss That Misses Me, Sterling Trio
DANCE RECORDS
18476 When Aunt Dinah's Daughter Hannah Bangs on That Piano, Six Brown Brothers
Chasing the Chickens, Fox-trot, Six Brown Brothers
35676 Oriental-Fox-trot, Joseph C. Smith's Orchestra
Dóda-La-Waltz, Joseph C. Smith's Orchestra
VOCAL AND INSTRUMENTAL RECORDS
45154 A Khaki Lad, Reinald Werrenrath
I Want to Go Back to "Blighly," Reinald Werrenrath
55094 A Dream of Love (Liszt), Victor Herbert's Orchestra
Madame Butterfly-Fantasia, Victor Herbert's Orchestra
18498 National Emblem March, United States Marine Band
"Lights Out" March, Arthur Pryor's Band
RED SEAL RECORDS
FRANCES ALDA, Soprano
64781 Laddie in Khaki, Ivor Novello
ENRICO CARUSO, Tenor-GIUSEPPE DE LUCA, Baritone
In Italian
89087 Force of Destiny-In segreto fu dunque violato? (Is My Secret Then Betrayed?), Verdi
ALMA GLUCK, Soprano-EREM ZIMBALIST, Violinist
88593 The Lost Chord, A. A. Proctor-Arthur Sullivan
JOHN McCORMACK, Tenor
64787 Love's Garden of Roses, Ruth Rutherford-Haydn Wood
JASCHA HEIFETZ, Violinist
(Pianoforte by André Benoist)
74570 La Ronde des Lutins (Dance of the Goblins), A. Bazzin
ERNESTINE SCHUMANN-HEINK, Contralto
87295 When the Boys Come Home, John Hay-Oley Speaks

COLUMBIA GRAPHOPHONE CO.

- A2608 Ever of Thee I'm Fondly Dreaming (Hall), Mezza soprano solo, orch. accomp., Barbara Maurel
Long, Long Ago (Bayly), Mezza soprano solo, orch. accomp., Barbara Maurel
49443 Bonnie Sweet Bessie (The Maid o' Dundee) (Gilbert), Soprano solo, orch. accomp., Hulda Lashanska
A2603 Lullaby (Brahms), Orch. accomp., Edna White Trumpet Quartet
The Old Refrain (Kreisler), Orch. accomp., Edna White Trumpet Quartet
49452 Hamlet, Brindisi (Drinking song) (Thomas), Baritone solo, George Baklanoff
A2590 Climb Up! Ye Chillum! Climb! (Kent), Baritone and male quartet, orch. accomp., Harry C. Browne and Peerless Quartet
Carve Dat Possum (Lucas), Baritone and male quartet, orch. accomp., Harry C. Browne and Peerless Quartet
A6059 Darling Nelly Gray (Hanby), Soprano solo, orch. accomp., Lucy Gates
My Old Kentucky Home (Foster), Soprano and male quartet, orch. accomp., Lucy Gates and Columbia Stellar Quartet
A2605 Songs of Your Childhood Days, Part 1, Intro, (1) "Daisy Bell" (Dacre), (2) "Because" (Bowers), (3) "When You Were Sweet Sixteen" (Thornton), Unaccomp., Signor Hurdí Gurdí Street Piano
Songs of Your Childhood Days, Part 2, Intro, (1) "Just as the Sun Went Down" (Udall), (2) "Mid the Green Fields of Virginia" (Harris), (3) "On the Banks of the Wabash Far Away" (Dresser), Unaccomp., Signor Hurdí Gurdí Street Piano
FIFE, DRUM AND BUGLE CORPS RECORD
A2592 On to Victory March, Part 1, Intro, (1) "The Campbells Are Coming" (2) "When Johnny Comes Marching Home Again," (3) "I'm Captain Jinks of the Horse Marines," (4) "Oh Carry Me Back," (5) "Coming Through the Rye," (Arr. and compiled by Charles A. Prince), Fife, Drum and Bugle Corps
On to Victory March, Part 2, Intro, (1) "The Girl I Left Behind Me," (2) "Dixie," (3) "Blue Bells of Scotland," (4) "Rally 'Round the Flag," (Arr. and compiled by Charles A. Prince), Fife, Drum and Bugle Corps
A2591 Sweet Genevieve (Tucker), Male voices, unaccomp., Columbia Stellar Quartet
You're the Flower of My Heart, Sweet Adeline (Armstrong), Male voices, unaccomp., Columbia Stellar Quartet
A6060 (a) Country Gardens (b) Shepherd's Hey (English Morris dances) (Set by Percy Grainger), Piano solo, Percy Grainger
Prelude in a Flat-(No. 17, Op. 18) (Chopin), Piano solo, Percy Grainger
A2593 Manzanillo (Mexican Dance) (Robyn), Prince's Orchestra
Shadows on the Water (Loumey), Prince's Orchestra
A6063 In Venice (Sellars), Orchestra with male voices, Gatty Sellars at the organ
Heart Throbs (Arnold), Prince's Orchestra
A2589 Abide With Me (Monk), Tenor solo, orch. accomp., Henry Burr
What a Friend We Have in Jesus (C. C. Converse), Tenor solo, orch. accomp., Henry Burr
DANCE RECORDS
A2596 Good-Bye Alexander (Creamer and Layton), Medley one-step, Intro, "Oh Frenchy," (Conrad), Wilber C. Sweatman's Original Jazz Band
The Darktown Strutters' Ball (Shelton Brooks), Medley fox-trot, Intro, "I'm Sorry I Made You Cry" (Clesi), Wilber C. Sweatman's Original Jazz Band
A2595 Mickey (Williams and Moret), Medley fox-trot, Intro, "Down in Hindustan" (Smith), Earl Fuller's Rector Novelty Orchestra

- Here Comes America (Glogau), Medley one-step, Intro, "Send Me Away With a Smile" (Piantadosi), Earl Fuller's Rector Novelty Orchestra
A6061 Maytime, Medley waltz, Intro, (1) "Sweetheart," (2) "The Road to Paradise," (3) "Selling Gowns" (S. Romberg), Jazirimba Orchestra
The Rainbow Girl, Medley, Waltz, Intro, (1) "Loves Ever New," (2) "My Rainbow Girl," (3) "In a Month or Two" (L. Hirsch), Jazirimba Orchestra
A6062 While the Incense Is Burning (Walter Smith), Medley fox-trot, Intro, (1) "I'll Take California for Mine" (Billy Frawley), (2) "In Dear Old Sunny Spain" (Jos. E. Howard), Violin and piano duet, Jockers Brothers
Tres Bien (Very Good) (Marvel), One-step, Violin and piano duet, Jockers Brothers
A6064 I'm Always Chasing Rainbows, Medley fox-trot, Intro, (1) "Typical Topical Tunes," (2) "A Kiss for Cinderella" (from "Oh! Look" (Carroll), Under the supervision of G. Hepburn Wilson, Prince's Band
Oh! Frenchy (Conrad), Medley one-step, Intro, (1) "Good-bye Alexander" (Creamer and Layton), (2) "After You've Gone" (Creamer and Layton), Under the supervision of G. Hepburn Wilson, Prince's Band

POPULAR HITS

- A2588 In the Good Old Irish Way (H. Von Tilzer), Baritone and Tenor duet, orch. accomp., Van and Schenck
My Marie (Van and Schenck), Baritone and Tenor duet, orch. accomp., Van and Schenck
A2587 Bobbie the Bomber (McCarron and Morgan), Character song, orch. accomp., Byron G. Harlan
What Yankee Doodle Says He'll Do, He'll Do (Harriman), Male voices, orch. accomp., Peerless Quartet
A2597 Cheer Up Father, Cheer Up Mother (Paley), Male voices, orch. accomp., Peerless Quartet
Bring Me a Letter From My Old Home Town (Anderson), Tenor solo, orch. accomp., Charles Harrison
A2601 It's a Long Way to Dear Old Broadway (Breuer), Tenor solo, orch. accomp., Irving Kaufman
The Last Long Mile (from "Toot! Toot!") (Breitenfeld), Baritone and male quartet, orch. accomp., Arthur Fields and Peerless Quartet
A2607 When the Sun Goes Down in Flanders (A. Von Tilzer), Tenor solo, orch. accomp., Hugh Donovan
Girls of France (Bryan, Leslie and Ruby), Tenor solo, orch. accomp., Hugh Donovan
A2599 When Uncle Joe Steps Into France (Winkler), Character song, orch. accomp., Collins and Harlan
Good-bye Alexander (Good-bye Honey-Boy) (Creamer and Layton), Character duet, orch. accomp., Farber Sisters
A2598 A Rainbow From the U. S. A. (from "Lamb's Gambol 1918" (Wenrich), Tenor and male quartet, orch. accomp., Henry Burr and Peerless Quartet
France, We Have Not Forgotten You (Anger), Tenor solo, orch. accomp., Henry Burr
A2600 Keep Your Head Down "Fritzie Boy" (Lieut. Rice and Morgan), Baritone and male quartet, orch. accomp., Arthur Fields and Peerless Quartet
Oh! You La! La! (Tush), Character song, orch. accomp., Harry Fox
A2602 Do Your Little Bitty-Bit (Right Now) (Braham), Male voices, orch. accomp., Peerless Quartet
The Beast of Berlin (We're Going to Get Him) (Calhoun), Baritone solo, orch. accomp., Arthur Hall
A2604 I Wish I Had Someone to Say Good-bye To (Mohr), Tenor solo, orch. accomp., Henry Burr
Good-bye Mother Machree (Ball), Tenor solo, orch. accomp., Henry Burr
NOVELTY HARMONICA SOLOS
A2594 The Jolly Lumber Jack (March) (Wagner), Harmonica solo, orch. accomp., Arthur Turelly
Toreador March (Unknown), Harmonica solo, orch. accomp., Arthur Turelly
FOREIGN LANGUAGE GEMS AND NOVELTY RECORDS
E2922 Puppchen, Circus organ
Shadow Walk, Circus organ
CHILDREN'S RECORDS
MUSIC OF THE BIRDS
A3016 Song of the Wood-Bird, Whistling solo, Birds in Springtime, Piccolo duet, Birds and the Brook (Stultz), Descriptive, Prince's Orchestra
A1767 Spring Blossoms (Capone), Prince's Orchestra
Birds of Spring, Mazurka, Prince's Orchestra
Canzonetta (D'Ambrosio), Prince's Orchestra
A2251 Simplicity (Lee), Whistling, Sybil Sanderson Fagan
L'Ardita (Magnetic Waltz) (Arditi), Whistling, Sybil Sanderson Fagan

EDISON AMBEROL RECORDS

- 28290 Par Toi, Divine Créatur-Le Coeur et la Main (Lecoq), Soprano and Baritone, in French, orch. accomp., Odette Le Fontenay and Orphée Langevin
REGULAR LIST
3560 Alice, I'm in Wonderland (Theodore Morse), Tenor, orch. accomp., Vernon Dalhart
3564 Any Old Place the Gang Goes (I'll Be There) (Wm. J. McKenna), Orch. accomp., Edward Meeker
3577 Bonnie Kate-Medley of Reels, Accordion, piano accomp. by Joe Linder, John J. Kimmel
3567 Blue Rose Waltz (Frederic Knight Logan), for dancing, Jaudas' Society Orchestra
3563 Clover Club (A "Fox-Trot Classic") (Felix Arndt), Imperial Marimba Band
3555 Daddy Mine (Wilson-Dubin), Contralto, orch. accomp., Helen Clark
3576 Down in the Jungle Land (Theo. Morse), Jungle song, orch. accomp., Arthur Collins and Byron G. Harlan
3574 Go Down, Moses (Let My People Go!) (Arr. by H. T. Burleigh), Tenor, orch. accomp., Reed Miller and Chorus
3559 Good and Bad, Coon Sketch, Billy Golden and Billy Heins
3570 Hearts of the World (Lee Johnson), Baritone, orch. accomp., Edward Allen
3571 Indianola (Henry-Onivas), Orch. accomp., Billy Murray

- 3572 Jazzin' Around-One-step (Earl Fuller), Earl Fuller's Famous Jazz Band
3562 Little Good for Nothing's Good for Something After All (Harry Von Tilzer), Mixed voices, orch. accomp., Harmony Four
3573 Little Old Log Cabin in the Lane (Will S. Hays), Mixed voices, orch. accomp., Metropolitan Quartet
3566 Maytime Waltz (Sigmund Romberg), Jazzirimba Orchestra
3565 Nails-Intermezzo (L. Delibes), Edison Concert Band
3538 Piccolo Pic (Walter L. Slater), Creator and His Band
3556 Poet and Peasant Overture, Part 1 (F. Von Suppé), American Symphony Orchestra
3557 Poet and Peasant Overture, Part 2 (F. Von Suppé), American Symphony Orchestra
3578 Second Mazurka (Benjamin Godard), Piano, André Benoist
3575 Somewhere in Hawaii (J. A. MacMeekin), Waikiki Hawaiian Orchestra (With Louise and Ferera)
3561 Sweetest Story Ever Told (R. M. Stults), Tenor, orch. accomp., Ralph Errolle
3568 We're All Going Calling on the Kaiser (Caddigan-Brennan), Baritone, orch. accomp., Arthur Fields and Chorus
3569 When I Send You a Picture of Berlin (You'll Know It's Over, "Over There," "I'm Coming Home") (Fay-Ryan-Dreyer), Tenor and male voices, orch. accomp., Billy Murray and Chorus

PATHE FRERES PHONOGRAPH CO.

POPULAR "HITS" OF THE MONTH

- 20423*Keep Your Head Down, Fritz Boy (Lieut. Gitz-Rice), Baritone, Arthur Fields
Uncle Sammy (Holzmann), Baritone, Arthur Fields
20424*But-After the Ball Was Over (from Ziegfeld "Follies of 1918") (Jackson), Baritone, Louis Winsch
Oui, Oui Marie (Wee Wee Marie) (Fisher), Baritone, Arthur Fields
20422*A Rainbow From the U. S. A. (Wenrich), Invincible Four
Do Your Little "Bitty Bit" (Braham), Baritone, Joe Remington
20425*I Wonder What They're Doing To-night (Egan), Baritone, Louis Winsch
Mandy and Me (Gumble), Campbell and Burr
20426*When We Meet in the Sweet Bye and Bye (Murphy), Sterling Trio
Mammy's Chocolate Soldier (Gottler), Contralto, Lois Fairman
20427*Mothers of America (You Have Done Your Share) (Porter), Invincible Four
If I Could Peep Through the Window To-night (McCarthy-Van-Schenck), Tenor, Harry McClaskey

NEW STANDARD BALLADS SUNG IN ENGLISH

- 27013 Dear Old Pal of Mine (Lieut. Gitz-Rice), Tenor, Paul Althouse
The Americans Come (Foster), Paul Althouse
25018 God Be With Our Boys To-night (Sanderson), Tenor, Craig Campbell
Roses of Picardy (Haydn Wood), Tenor, Craig Campbell
20418 The House of Memories (Aylward), Baritone, William Simmons
I'm Wearing Awa' (Arthur Foote), Baritone, William Simmons

FAMOUS CHURCH SCENE FROM "THE OLD HOME-STEAD"

- 40134 Church Scene (from "Old Homestead"), Organ accomp., Invincible Four
Songs My Mother Used to Sing (Smith), Ruth Lenox and Henry Burr

RECORDINGS BY METROPOLITAN ORCHESTRA

- 59059 Marche Slave (Tschaiakowsky), Metropolitan Opera House Orchestra, Conducted by Gennaro Papi
Jewels of the Madonna (Wolf-Ferrari) "Intermezzo," Act III, Metropolitan Opera House Orchestra, Conducted by Gennaro Papi

NEW PATHE "DE LUXE" DANCE RECORDS

- 20428*Smiles (Roberts), Fox-trot, American Republic Band
Dream True (Rose-David), Waltz, Pathé Dance Orchestra
29215*When I Hear a Syncopated Tune (from Ziegfeld "Follies of 1918") (Hirsch), Medley fox-trot, Intro, "Any Old Time at All," American Republic Band

HARRY VON TILZER'S "HIT MEDLEY," INTRO, "WHEN I SEND YOU A PICTURE OF BERLIN," "THE LITTLE GOOD FOR NOTHING'S GOOD FOR SOMETHING," "YOU'RE A BETTER MAN THAN I AM, GUNGA-DIN," "BYE AND BYE."

- 20429*Oriental (Rose), One-step-saxophone and piano duet, Wadsworth and Arden
Just Blue (Wadsworth-Arden), Fox-trot-saxophone and piano duet, Wadsworth and Arden
NEW PIANO SOLOS BY RUDOLPH GANZ
27014 The Music Box, Op. 32 (Liadow), Piano solo, Rudolph Ganz
Passacaglia (Pastoral Suite) (Scott), Piano solo, Rudolph Ganz

STANDARD SAXOPHONE SOLOS

- 20421 Al Fresco (Victor Herbert), "Intermezzo," Saxophone solo, piano accomp., Duane Sawyer
La Seduccion (Noceti) "Argentine Intermezzo," Saxophone solo, piano accomp., Duane Sawyer

GENUINE CHINESE RECORD-MADE IN CHINA AND ISSUED AS A NOVELTY

- 40136 Chinese Vocal Record, recorded in Canton, China Part 1, Chinese Vocal Record, recorded in Canton, China Part 2, AIRS OF SCOTLAND PLAYED BY BAGPIPE BAND
20403 Medley of "Scottish Airs," No. 1, Intro, "The 71st Highlanders March," "The Braes of Tullymet," "Thomson's Dirk," Lovat's Bagpipe Band of New York with Harry Lauder American Tours

Medley of "National Airs," Intro, "The Mar-seillaise," "The Maple Leaf Forever," "Rule Britannia," Lovat's Bagpipe Band of New York with Harry Lauder American Tours

- 54013 Quand Madelon (Robert) in French, Tenor, Lucien Muratore
NEW OPERATIC VOCAL RECORDINGS
54016 Madama Butterfly (Puccini) "Un bel di vedremo" (Some Day He'll Come) in Italian, Soprano, Claudia Muzio
60072 Don Giovanni (Mozart) "Nella bionda" (The Fair One) in Italian, Basso, Adamo Didur
Marriage of Figaro (Mozart) "Non piu andrai far fallone amoros" (Now Your Days of Philandering Are Over) in Italian, Basso, Adamo Didur

RECORD BULLETINS FOR OCTOBER (Continued from page 109)

- NEW INSTRUMENTAL RECORDS
20405 When You Come Home (Squire). Cornet solo, Serg. Leggett
The Garden of Your Heart (Dorel). Cornet solo, Serg. Leggett
20420 Faust Waltz (Gounod). Accordion duet, Peppino and Perry
Mazurka de Concert (A Love Thought) (Migliavacca). Accordion solo, Joseph Peppino
NEW BAND AND ORCHESTRA RECORDS
40135 Funeral March (Chopin). American Regimental Band
Marche Heroique (Saint-Saens) American Regimental Band
20419 The Elks' March (Lake). American Regimental Band
The Cruiser Harvard March (Strube). American Regimental Band
20407 Starland "Intermezzo" Pathe Salon Orchestra
Valse Sincere "Concert Valse," Pathe Salon Orchestra
59009 La Tosca (Puccini) "O dolci mani" (Gentle Hands) in Italian. Tenor, Tito Schipa
I Pagliacci (Leoncavalla) "Serenata" (Serenade) in Italian. Tenor, Tito Schipa
59011 Andrea Chenier (Giordano) "Un di m'era di gioia" (A Joyful Epoch) in Italian. Baritone, Taurino Parvis
Hamlet (Thomas) "Come il romito fior" (Pale as a Flower) in Italian. Baritone, Taurino Parvis
60056 La Tosca (Puccini) "Monologo di Scarpia" (Venal, My Enemies Call Me) in Italian. Baritone, Giacomo Rimini
Rigoletto (Verdi) "Parl' s'iamo" (We Are Equal) in Italian. Baritone, Giacomo Rimini
60055 Norma (Bellini) "Casta Diva" (Queen of Heaven) in Italian. Soprano, Rosa Raisa
L'Africana (Meyerbeer) "In grembo-a me" (Slumber Song) in Italian. Soprano, Rosa Raisa
62003 Elixir D'Amore (Donizetti) "Una furtiva lacrima" (A Furtive Tear) in Italian. Tenor, Aristodemo Giorgini
Martha (Flotow) "M'appari tutto amor" (Like a Dream) in Italian. Tenor, Aristodemo Giorgini
63019 La Gioconda (Ponchielli) "Suicidio" (Suicide Remains) in Italian. Soprano, Claudia Muzio
Otello (Verdi) "Ave Maria," in Italian. Soprano, Claudia Muzio
63022 Madama Butterfly (Puccini) "Ancora un passo" (Entrance of Butterfly, Act 1) in Italian. Soprano, Claudia Muzio
La Boheme (Puccini) "Mi chiamano Mimi" (My Name Is Mimi) in Italian. Soprano, Claudia Muzio
SINGLE FACE RECORDS
54002 La Marseillaise (de L'Isle). Tenor, Lucien Muratore

EMERSON PHONOGRAPH CO.

- Seven-inch Double Disc
Thirty-five Cent Records
PATRIOTIC AND POPULAR SONG HITS
7401 Oh! How I Hate to Get Up In the Morning (Irving Berlin). Character song, orch. accomp., Eddie Nelson
Let's Keep the Glow in Old Glory (Nesbit-Speroy). Patriotic solo, orch. accomp., Harry Evans
7398 On the Level You're a Little Devil (But I'll Soon Make an Angel of You) (Schwartz-Young). Baritone solo, orch. accomp., Eddie Nelson
Loveland Bay (Joe Davis). Tenor solo, orch. accomp., Frank Woods
7405 Everything Is Peaches Down in Georgia (Clarke-Ager-Meyer). Vocal trio, orch. accomp., Sterling Trio
The Sister of Rosie O'Grady (Henry-Warren). Tenor solo, orch. accomp., Frank Woods
7403 Our Country's In It Now (We've Got to Win It Now) (Empey-McCarron-Morgan). Patriotic solo, orch. accomp., Harry Evans
If I Could Peep Through the Window To-night (McCarthy-Van-Schenck). Tenor solo, orch. accomp., George Gordon
7402 After You've Gone (Creamer-Layton). Baritone solo, orch. accomp., Eddie Nelson
7402 My Little Rose of the Poppy Field (Joe Davis). Tenor solo, orch. accomp., Frank Woods
7404 Good-bye Alexander, Good-bye Honey Boy (Creamer-Layton). Character duet, orch. accomp., Collins and Harlan
I'm Going to Spend My Vacation With a Dear Old Relation (Wilson-Silvers). Patriotic solo, orch. accomp., D. (Bud) Bernie
7397 Mandy and Me (McKenna-Gumble). Tenor duet, orch. accomp., Rice and Rhodes
Where Have You Been Hiding All These Years? (Mitchell-Cox-Kraus). Baritone solo, orch. accomp., Eddie Nelson
7406 Uncle Sammy (Abe Holzmann). Vocal march, accompanied by Emerson Military Band, D. (Bud) Bernie
We're Bound to Win With Boys Like You (Brockman-Vincent). Patriotic solo, orch. accomp., George Gordon

DANCE AND BAND HITS

- 7407 Texas Fox-Trot (David W. Guion). Emerson Military Band
Chinese Jazz (Chris. Smith). One-step, Emerson Military Band
7399 I Want to Learn to Dance (Hubbell-Miller). Fox-trot, Emerson Military Band
Kee to Kee Rag (Platzman-Eastward). Fox-trot. Banjo and accordion duet, Van Eps and Boudini
7400 Since I Met Wonderful You (Hubbell-Grant). One-step, Emerson Military Band
April Smiles (Depret-Laurendesu). Waltz, Emerson Military Band
7408 General Pershing (Carl D. Vandersloot). March and one-step, Emerson Military Band
Walk Her (David Walker). One-step, Emerson Military Band

EMPIRE TALKING MACHINE CO.

- POPULAR PATRIOTIC SONGS OF THE DAY
6201 There's a Long, Long Trail (Elliott). Baritone solo, orch. accomp., Ben Pilgrim
Homeward Bound (Meyer). Duet, orch. accomp., Ben Pilgrim and Arthur Fields
6202 Joan of Arc (Wells). Baritone solo, orch. accomp., Willie Weston
The Star-Spangled Banner (Key). George Stewart and Male Chorus
6205 It's a Long Way to Berlin (Flatow). Tenor solo, orch. accomp., Fred Fairbanks
Over There (Cohan). Baritone solo, orch. accomp., Willie Weston

- 6204 I'm Writing to You, Sammy (Harriman). Tenor solo, orch. accomp., Arthur Fields
Tom, Dick, Harry and Jack (Ager). Tenor solo, orch. accomp., Arthur Fields
BALLADS
6205 All the World Will Be Jealous of Me (Ball). Orch. accomp., Irving Kaufman
There's Another Angel Now in Old Killarney (Bernard). Empire Male Quartet
6206 A Perfect Day (Carrie Jacobs-Bond). Sweet Little Buttercup (Paley). Orch. accomp., Empire Male Quartet
6207 Chin Chin Chinaman (Hanley). Orch. accomp., Empire Male Quartet
Yock-a-Hilo Town (Donaldson). Orch. accomp., Empire Male Quartet
6208 In the Land of Wedding Bells (Meyer). Orch. accomp., Campbell and Burr
Give Me the Moonlight, Give Me the Girl (Von Tilzer). Empire Male Quartet
6210 My Sweet Hawaiian Rose (Ray-Ruddy). Hawaiian accomp., Louis Winsch
Hawaiian Sunshine (Gilbert-Morgan). Tenor solo, Hawaiian accomp., Sam Ash
6211 There It Goes Again (Jentes). Tenor solo, orch. accomp., Ira Allen
Honest Injun (Sterling-Moran-Von Tilzer). Orch. accomp., Collins and Harlan
MUSICAL COMEDY
6209 Wait Till the Cows Come Home (Caryll). Orch. accomp., Campbell and Burr
Jack o' Lantern (Caldwell-Burnside-Caryll). Medley, Empire Military Band
INSTRUMENTAL SELECTIONS
6212 Hawaiian Dreams (Herbert-Marple). Hawaiian Guitars, Louise and Perera
The Glow Worm (Lincke). Hawaiian Guitars, Louise and Perera
6213 Mammy's Little Coal Black Rose (Whiting). Blue and White Marimba Band
Spooky Spooks (Claypoole). Blue and White Marimba Band
6214 A Bunch of Blues. (Arranged by Klaas). Accordion solo, Chas. Klaas
A Scotch Highball. (Arranged by Boudini). Accordion solo, Boudini Bros.
6215 The Sunshine of Your Smile (Ray). Violin solo, orch. accomp., Jan Rubini
Hearts and Flowers (Tobani). Violin Solo, piano accomp., Jean Ebersole
POPULAR JAZZ AND DANCE HITS
6216 Long Boy (Herschel-Walker). One-step, Empire Military Band
When You Come Back (Frey). One-step, Empire Military Band
6217 The Moonlight Waltz (Logan). Empire Band
For the Freedom of the World (Zemanick). Empire Military Band
6218 Sweet Emaline, My Gal (Creamer-Layton). One-step, Empire Dance Orchestra
Smile and Show Your Dimple (Berlin). Medley fox-trot, Empire Band
6219 Boogie Rag (Sweetman). Fox-trot, Sweetman and his Jazz Band
Hawaiian Blues (Murray). Fox-trot, Van Epps-Banta Trio
6220 Stockyard Blues (Pinkard). Piano, saxophone and banjo, Van Epps Trio
When the Saxophone Is Playing (Hirsch). Van Epps Trio

LATEST OKEH RECORDS

- DANCES
1040 That's It—Fox-trot. Jazarimba Orchestra
Peacock Strut. Xylophone and Rega's Novelty Dance Orchestra
1041 Watermelon Whispers—Fox-trot, Xylophone and Rega's Novelty Dance Orchestra
South American Fox-trot, Rega's Novelty Dance Orchestra
1042 Oriental Fox-trot. Majestic Hotel Dance Orchestra
Texas Fox-trot. Majestic Hotel Dance Orchestra
1067 Some Shape—One-step, Van Eps Quartet
Hello, Central, Give Me No-Man's Land—Fox-trot, Van Eps Quartet
1068 Lisztiana—One-step, Band
Sinbad Medley—Fox-trot, Van Eps Quartet
HUMOROUS
1066 Scheme to Enter Heaven. Golden and Heins
O'Brien's Trials and Mishaps. Geo. L. Thompson
INSTRUMENTAL
1032 Les Millions D'Arlequin. Concert Band
Tschaiakowsky's Melodies. Concert Band
1034 Faust—Ballet Music No. 1. Concert Band
Faust—Ballet Music No. 2. Concert Band
1035 Hearts and Flowers. Concert Orchestra
Schubert's Serenade. Cello and Orchestra
1036 Twinkling Star Polka. Piccolo, Xylophone and Orchestra
Schön Rosmarin. Xylophone and Orchestra
1037 Larghetto. Cello Selection
Air de J. S. Bach. Cello Selections
1038 Valse Chopin. Piano Selection
Nocturne Chopin. Piano Selection
1039 Andante Cantabile in D Major. Berkshire String Orchestra
Romanze in G Minor. Berkshire String Orchestra
MARCHES
1035 Stars and Stripes Forever—March. Military Band
Up the Street—March. Military Band
PATRIOTIC AND POPULAR SONG HITS
1057 Star-Spangled Banner. Croxton Trio
Battle Hymn of the Republic. Croxton Trio
1069 One For All, All For One. Sterling Trio
America, Here's For You. Harry Ellis
1070 We're Bound to Win With Boys Like You, Franklin Kent
While You're Away. Harry Ellis
1071 Indianola. Arthur Hall
When Uncle Joe Steps Into France, Collins and Harlan
1072 I'm Sorry I Made You Cry. Irving Kaufman
I Hate to Lose You. Elaine Gordon
1073 Hearts of the World. Charles Hart
When You Come Back. Sterling Trio
1074 Oh! How I Hate to Get Up in the Morning, Irving Kaufman
Good Morning, Mr. Zip, Zip, Zip. Arthur Fields
Cheer Up, Father, Cheer Up, Mother. Peerless Quartet
Hello, Central, Give Me No-Man's Land, Irving Kaufman
1076 Good-bye, Alexander. Collins and Harlan
Mammy's Chocolate Soldier. Harvey Hindernymer
Merrily We'll Roll Along. Sterling Trio
1058 Peach Jam Makin' Time in Dixie, Jones and Thompson
1056 Ship and Trench Song. Henry Burr
When the Great Red Dawn is Shining. Joseph Phillips
1059 Alice, I'm in Wonderland. Sterling Trio
Because You Believe in Me. Greek Evans
1060 Chimes of Normandy. Sterling Trio
When the Cows Come Home ("Jack o' Lantern"), Joseph Phillips
1061 Mothers o' America. Harry Ellis
Oh, Frenchy. Elaine Gordon
1062 There's a Lump of Sugar in Dixie, Collins and Harlan
Bye and Bye. Jones and Thompson

- 1063 We'll Do Our Share. Sterling Trio
Bobby the Bomber. Byron G. Harlan
1065 I Miss the Mississippi Miss. Collins and Harlan
Down in Jungland. Collins and Harlan
STANDARD VOCAL AND HEART SONGS
1043 Mother o' Mine. Chas. Hart
Bring Back the Sunshine. Lewis James
Somewhere a Voice is Calling. Harry McClaskey
Tell Her I Love Her So. Reed Miller
1046 Oloha Oe—Farewell to Thee. Sterling Trio
Gypsy Love Song. Frederick Wheeler
1047 Asthore. Jos. Phillips
Oh, Promise Me. Marie Morrissy
1048 Dreams. Frederick Wheeler
Kiss Me Again. Grace Kerns
1049 Anchored. Frederick Wheeler
Irish Love Song. Inez Barbour
1053 Good-bye, Sweet Day. Croxton Quartet
Angel's Serenade. Grace Kerns
1054 Morning. Lewis James
When the Bell in the Lighthouse. Frank Croxton
1055 Under the Greenwood Tree. Inez Barbour
Pirates of Penzance. Grace Kerns

EMERSON PHONOGRAPH CO.

- Sixty-five Cent Records
PATRIOTIC AND POPULAR
979 When You Come Back and You Will Come Back There's the Whole World Waiting for You (George M. Cohan). Patriotic solo, orch. accomp., Eddie Nelson
When I Get Out in No Man's Land (I Can't Be Bothered With No Mule) (Skidmore-Walker). Character song, orch. accomp., Arthur Collins
970 Oh! How I Hate to Get Up In the Morning (Irving Berlin). Character song, orch. accomp., Eddie Nelson
Our Country's In It Now (We've Got to Win It Now) (Empey-McCarron-Morgan). Patriotic solo, orch. accomp., Greek Evans
978 My Belgian Rose (Benoit-Levenson-Carton). Tenor solo, orch. accomp., Henry Burr
Mandy and Me (McKenna-Gumble). Tenor duet, orch. accomp., Burr and Campbell
973 Everything Is Peaches Down in Georgia (Clarke-Ager-Meyer). Vocal trio, orch. accomp., Sterling Trio
The Sister of Rosie O'Grady (Henry-Warren). Tenor solo, orch. accomp., Frank Woods
971 After You've Gone (Creamer-Layton). Baritone solo, orch. accomp., Eddie Nelson
Good-bye Alexander, Good-bye Honey Boy (Creamer-Layton). Character duet, orch. accomp., Collins and Harlan
974 Uncle Sammy (Abe Holzmann). Vocal march, accompanied by Emerson Military Band, Arthur Fields
A Rainbow From the U. S. A. (Mahoney-Jerome-Wenrich). Vocal quartet, orch. accomp., Peerless Quartet
972 America, He's for You (Andrew Sterling). Patriotic solo, orch. accomp., Henry Burr
Let's Keep the Glow in Old Glory (Nesbit-Speroy). Patriotic Solo, orch. accomp., Greek Evans
969 I'm Going to Spend My Vacation With a Dear Old Relation (Wilson-Silvers). Patriotic solo, orch. accomp., Arthur Fields
When Uncle Joe Steps Into France (Grossman-Winkle). Tenor and baritone duet, orch. accomp., Collins and Harlan
977 The Yanks Are At It Again (Brown-Cowan). Patriotic solo, orch. accomp., Arthur Fields
If I Could Peep Through the Window To-night (McCarthy-Van-Schenck). Tenor solo, orch. accomp., George Gordon
DANCE AND BAND HITS
980 Rose Room (Art Hickman). Fox-trot, Emerson Military Band
Chinese Jazz (Chris. Smith). One-step, Emerson Military Band
976 Texas Fox-Trot (David W. Guion). Emerson Military Band
Walk Her (David Walker). One-step, Emerson Military Band
975 General Pershing (Carl D. Vandersloot). March and one-step, Emerson Military Band
April Smiles (Depret-Laurendeau). Waltz, Emerson Military Band

LYRAPHONE CO. OF AMERICA

- CONCERT AND OPERATIC SERIES
7111 Caro Nome (from "Rigoletto") (Verdi). Orch. accomp., Regina Vicarino, Soprano
Good Night Quartet (from "Martha") (Flotow). Orch. accomp., Lyric Opera Quartet
7112 Il Bacio (The Kiss), Vocal Waltz (Arditi). Orch. accomp., Regina Vicarino, Soprano
Selections from "Cavalleria Rusticana." Lyric Symphony Orchestra
PATRIOTIC AND POPULAR SONG HITS
6139 The Americans Come (Fay Foster). Orch. accomp., John Vernon, Tenor
Yankee Doodle's Going to Berlin (Kent Perkins). Orch. accomp., John Vernon, Tenor
6140 Freedom for All Forever (Lieut. B. C. Hilliam). Orch. accomp., John Vernon, Tenor
We'll Never Let the Old Flag Fall. Orch. accomp., John Vernon, Tenor
5130 Good-bye, Mother Machree (E. R. Ball). Orch. accomp., Henry Burr, Tenor
When I Get Back to My American Blighty (Fields-Morse). Orch. accomp., Arthur Fields, Baritone
5131, Smiles (Callahan-Roberts). Orch. accomp., Henry Burr, Tenor, and Marie Morrissy, Contralto
I Miss That Mississippi Miss That Misses Me (Wendling). Orch. accomp., Lyric Male Quartet
5132 K-K-K-Katy (O'Hara). Orch. accomp., Harry Williams, Baritone
We'll Never Let the Old Flag Fall. Orch. accomp., Harry Williams, Baritone
HAWAIIAN RECORDS
4142 Aloha Oe (Likuokalani). Kalawao Hawaiian Orchestra
Ua Like No a Like (Sweet Constancy). Kalawao Hawaiian Orchestra
4143 Yaaka Hula Hickey Dula (Wendling-Younger). Kalawao Hawaiian Orchestra
Kilina Waltz. Kalawao Hawaiian Orchestra
DANCE RECORDS
4144 Calicoco—Fox-trot. Lyric Dance Band
A Baby's Prayer at Twilight—One-step, Lyric Dance Band
4145 Indianola—Fox-trot. Lyric Dance Band
Homeward Bound—Medley One-step, Lyric Dance Band
4146 The Memphis Blues—Fox-trot. Piano and Saxophone Duet, Bennett Brothers
Dolores—Waltz. Accordion Duet, Brown and Edwards

The Kaiser has not invested in War Savings Stamps. Are you like the Kaiser?

Some Leading Jobbers of Talking Machines in America

1856 **WURLITZER** 1916

VICTOR
DISTRIBUTORS
VICTORS EXCLUSIVELY

We make a specialty of getting the order out on time—every time.

The Rudolph Wurlitzer Co.
CINCINNATI AND CHICAGO
Two points of supply; order from the nearer

TEST IT. 

OUR VICTOR

Record Service

has a reputation for efficiency.
Suppose you try it.

E. F. DROOP & SONS CO.
1300 G. STREET, WASHINGTON, D. C.
231 N. HOWARD STREET, BALTIMORE, MD



YAHR & LANGE DRUG CO.
MILWAUKEE, WIS.

Wholesale Distributors for

THE INSTRUMENT OF QUALITY

Sonora 
CLEAR AS A BELL

in Wisconsin and Upper Michigan

W. J. DYER & BRO.
NORTHWESTERN DISTRIBUTORS

OF THE

VICTOR
Machines, Records and Supplies

 Shipped Promptly to all Points in the Northwest

STARR Phonographs and GENNETT Records

Complete Stock and REAL Service

Crafts-Starr
PHONOGRAPH CO.

Factory Distributors
218-220 NORTH SECOND STREET, RICHMOND, VIRGINIA
Write for Dealers' Proposition

Smith, Kline & French Co.
PHILADELPHIA

Wholesale Distributors for

THE INSTRUMENT OF QUALITY

Sonora 
CLEAR AS A BELL

In PENNSYLVANIA, NEW JERSEY and DELAWARE

Hillman & Son Phonograph Co.
Wheeling, West Virginia

Exclusive Wholesale Distributors for West Virginia and Virginia

THE INSTRUMENT OF QUALITY

Sonora 
CLEAR AS A BELL

All models shipped promptly from our large warehouse, 1126 Main Street
Diamond Needles and Sapphire Needles for Sale

Southern Victor Dealers
Largest Stock VICTROLAS and RECORDS.
Prompt Shipment and Low Freight Rates.

WALTER D. MOSES & CO.
Oldest Music House in Virginia or North Carolina.
RICHMOND, VA.

OLIVER DITSON COMPANY
BOSTON

Largest VICTOR Talking Machine Distributors East of Chicago.
Creators of "The Fastest Victor Service." Let us tell you more about our service.

C. L. Marshall & Co.
Wholesale Distributors for Michigan

THE INSTRUMENT OF QUALITY

Sonora 
CLEAR AS A BELL

The Ohio Sales Company, Inc.
Wholesale Distributors for Ohio
810-11 EMPIRE BLDG., DETROIT, MICH.

Mickel Bros. Co.

Omaha, Nebraska
Des Moines, Iowa

Victor Distributors

ROUNTREE-CHERRY
RICHMOND VIRGINIA

Wholesale Distributors for

THE INSTRUMENT OF QUALITY

Sonora 
CLEAR AS A BELL

You  *above all must be satisfied!*
IN NORTH AND SOUTH CAROLINA

Sherman, Clay & Co.

San Francisco, Los Angeles, Portland, Seattle, Spokane
PACIFIC COAST DISTRIBUTORS OF VICTOR PRODUCTS

The PERRY B. WHITSIT CO.
Distributors of
Victrolas and Victor Records
COLUMBUS, OHIO

Victor Exclusively
EASTERN TALKING MACHINE CO.
177 Tremont Street, Boston
VICTOR DISTRIBUTORS

The Electric Supply & Equipment Co.
Exclusive Wholesale Distributors for Southern New England

THE INSTRUMENT OF QUALITY

Sonora 
CLEAR AS A BELL

Complete stocks carried in Boston and Hartford
Little Bldg. 103 Allyn St.
BOSTON, MASS. HARTFORD, CONN.

Have You Noted the Growth of This Department?

Special Rates for Jobbers' Directory on Application

During the past six months this Jobbers' Directory has grown steadily in importance. It affords progressive jobbers an opportunity to keep their names before the dealers consistently and regularly, and provides representation in the Jobbers' Directory of the publication which is the recognized authority of the industry.

Join the progressive jobbers on this page next month.

THE NEW EDISON



A Master Product of A Master Mind

JOBBER'S OF THE NEW EDISON, EDISON RE-CREATIONS, THE NEW EDISON DIAMOND AMBEROLA AND BLUE AMBEROL RECORDS

CALIFORNIA
Los Angeles—Edison Phonographs, Ltd.
San Francisco—Edison Phonographs, Ltd.

COLORADO
Denver—Denver Dry Goods Co.

CONNECTICUT
New Haven—Pardee-Ellenberger Co., Inc.

GEORGIA
Atlanta—Phonographs, Inc.

ILLINOIS
Chicago—The Phonograph Co.
James I. Lyons. (Amberola only.)

INDIANA
Indianapolis—Kipp Phonograph Co.

IOWA
Des Moines—Harger & Blish.
Sioux City—Harger & Blish.

LOUISIANA
New Orleans—Diamond Music Co., Inc.

MASSACHUSETTS
Boston—Pardee-Ellenberger Co.

MICHIGAN
Detroit—Phonograph Co., of Detroit.

MINNESOTA
Minneapolis—Laurence H. Lucker.

MISSOURI
Kansas City—The Phonograph Co. of Kansas City.

MONTANA
Helena—Montana Phonograph Co.

NEBRASKA
Omaha—Shultz Bros.

NEW JERSEY
Paterson—James K. O'Dea (Amberola only).

NEW YORK
Alhany—American Phonograph Co.

New York—The Phonograph Corp. of Manhattan.

Syracuse—Frank E. Bolway & Son, Inc.

Buffalo—W. D. & C. N. Andrews Co. (Amberola only.)

OHIO
Cincinnati—The Phonograph Co.

Cleveland—The Phonograph Co.

OREGON
Portland—Edison Phonographs, Ltd.

PENNSYLVANIA
Philadelphia—Girard Phonograph Co.

Pittsburgh—Buehn Phonograph Co.

Williamsport—W. A. Myers.

RHODE ISLAND
Providence—J. A. Foster Co. (Amberola only.)

TEXAS
Dallas—Texas-Oklahoma Phonograph Co.

UTAH
Ogden—Proudfit Sporting Goods Co.

VIRGINIA
Richmond—The C. B. Haynes Co., Inc.

WISCONSIN
Milwaukee—The Phonograph Co. of Milwaukee.

CANADA
Montreal—R. S. Williams & Sons Co., Ltd.

St. John—W. H. Thorne & Co., Ltd.

Toronto—R. S. Williams & Sons Co., Ltd.

Vancouver—Kent Piano Co., Ltd.

Winnipeg—R. S. Williams & Sons Co., Ltd.

Calgary—R. S. Williams & Sons Co., Ltd.

The TALKING MACHINE WORLD

For the
makers &
sellers of
talking
machines

Published Each Month by Edward Lyman Bill, Inc., at 373 Fourth Ave., New York, October 15, 1918



The best-known trade-mark in the world

"The Victor talking machine's design, 'His Master's Voice,' has become a household word, and the quaint little fox terrier at attention before the horn is familiar to more Americans than any of the world's great masterpieces"—*Collier's Weekly*.

“LET the people’s response to the Fourth Liberty Loan express the measure of their devotion to the ideals which have guided the country from its discovery until now, and of their determined purpose to defend them and guarantee their triumph.”

—Woodrow Wilson

Only your conscience knows whether you have bought all the Liberty Bonds you can.

Have you?

This advertisement contributed by

THE INSTRUMENT OF QUALITY
Sonora
CLEAR AS A BELL 

The Highest Class Talking Machine in the World

The Talking Machine World

Vol. 14. No. 10

New York, October 15, 1918

Price Twenty-five Cents

TRADE SHOULD FIGHT NEW FLOOR TAX OF 10 PER CENT.

Clause in New Revenue Bill, Which Is Now Before the Senate, Works a Hardship to Dealers, and They Should File Protests With Their Senators at Once

Talking machine merchants generally, it appears, in perusing the clauses of the new War Revenue bill recently passed by the House of Representatives and now before the Senate for consideration, took it for granted that the 10 per cent. on the manufacturer's price on talking machines and records, as provided for in Section 900, would be all the tax of that nature they would be called upon to bear. By reading along to Section 909 of the same bill, however, it is found that upon all such articles, other than second-hand articles, enumerated in Section 900, and upon which no tax was imposed under the War Revenue Act of 1917, a special floor tax of 10 per cent. is to be levied and paid by those persons in whose possession the goods are held at the time the bill becomes a law. In other words, on every talking machine, pipe organ, piano, music roll and record in his store, when the new act becomes operative, the merchant must pay a tax of 10 per cent. on the cost price.

The unfairness of the clause lies in the fact that in the case of talking machines, piano players, music rolls and records the dealer has been called upon to pay indirectly and to the manufacturer a tax of 3 per cent. on the manufacturer's price as provided for in the Revenue Act of 1917. In other words, through ordering early and getting the goods into his store he will be forced, if the section is included in the final law, to pay an additional 10 per cent. tax,

or 13 per cent. in all as against a flat tax of 10 per cent. on the manufacturer's price should he order after the law becomes operative. There is no provision made apparently for paying the difference between the two taxes, as provided for in the case of tobacco and other articles which have been taxed.

By referring to Sections 600 and 602 of the Revenue Act of 1917, it appears that the framers of the new bill feel conscious that they overlooked a bet in the 1917 measure by not placing a floor tax on retail stocks, and seek to remedy the situation in their own point of view in the new measure.

The 1917 law, as is generally known, provided for the collection of a floor tax amounting to half the regular tax, or 1½ per cent. only upon talking machines, etc., in the hands of wholesalers, thereby leaving the retailer tax free.

It would be well for those retailers with large interests at stake to file protests as individuals with their respective Senatorial representatives, pointing out particularly the fact that they apparently will be penalized under the new law to the extent of a 3 per cent. tax at least, through the fact that in order to relieve the manufacturing and transportation situation they ordered early, and have carried as much stock as they could get hold of for several months in order to meet the coming demand with as little confusion as possible.

CONCERTS FOR THE CHILDREN

How the Youngsters of Colorado Springs Enjoy Their Open Air Pleasures Through Aid of the Victrola—Conveys Value of Music

COLORADO SPRINGS, COLO., October 3.—An interesting event recently in this city was the Victrola concert given at Prospect Lake playground by J. D. Falkenburg, manager of the Victrola department of the Knight-Campbell Music Co., which, judging from the picture herewith, demonstrates the interest that is taken by children in concerts of this character. Victrolas have



Victrola Entertains Kiddies

been installed in all the public schools of Colorado Springs, and Mr. Falkenburg has started a campaign to furnish music for the kiddies in the local playgrounds. Mr. Falkenburg, by the way, may be seen standing by the side of the Victrola in the picture. The affair was attended by a large number of children, who insisted on hearing their favorite tunes over and over again.

VILE CONSPIRACY UNEARTHED

How Silas Bent Proposes to Bring the Melodies of Tree-Toads to Harlem

One of the most entertaining columns of the New York Evening Sun is that conducted by Don Marquis, whose correspondents are always presenting startling thoughts that stimulate the mentality of readers. For instance, Silas Bent, an old friend of the column, who just returned from a sojourn among those familiar "birds" of New Jersey, whose song may be termed a bite and whose buzzing is like a war plane in full action, pours forth his soul like this in a recent issue:

"Sir: The idea came to me while spending a night at Haworth. I reflected then, as I had reflected often before, that the chief soporific in country life is the song of the tree-toads at bedtime; and in a flash, just like that! it occurred to me that the city dweller could as easily as not have this vocal narcotic if only some one would found a tree-toad farm and train the beasts to sing on window ledges. This, you must admit, was a master stroke, but it was to be still further improved. Why not make a phonograph record of the tree-toad chorus? Then one could have all the somnolent witchery of Haworth in any Harlem flat. The process greatly reduces the tree-toad overhead, if you get what I mean, and makes the serenade available for every home. It puts the kibosh on commuting. It strips concrete and asphalt of their horrors and brings the verdant voices of the countryside to the city of dreadful night. Is it not a world-shaking idea?"

This is reproduced in The Talking Machine World simply because of its very "original" and "striking" idea of bringing the "joys" of suburban life to Harlemites via the talking machine record. Harlemites are to be heard from.

John A. Hofheimer has recently taken charge of the Victrola department of the Dry-Block Mercantile Co., in Memphis, Tenn., having formerly occupied a similar position with B. Lowenstein & Bro. in the same city.

DISTRIBUTION OF MUSIC A VITAL PATRIOTIC ACTIVITY

Music as a Factor in Maintaining the Morale of the Nation and in Stimulating Activity in War, Emphasized by J. I. Carroll, Manager of Sales of the Emerson Phonograph Co.

War draws upon many sources for its successful prosecution. It is fought behind the lines vigorously, while men battle valiantly at the front.

All thinking men concede that it matters little how bravely men may fight, if the "morale" of the people at home is not kept at full strength the glorious sacrifice of the loyal sons in the trenches is dangerously impaired, if not entirely nullified.

In the public press we read much of the fast ebbing "morale" not alone among the troops of the enemy, but more particularly among their folks at home. Right now in certain of these countries the Allies see impending the collapse of the armies battling for their respective sovereigns, because of serious disturbances among their people at home—the destruction resulting from lack of moral support.

It is agreed by military authorities that moral support by those at home is of the very utmost importance; absolutely essential to ultimate victory; then:

That which will best encourage the continued and unflagging "morale" of the people is a patriotic influence which must not for an instant be allowed to diminish in the minutest degree.

What will produce that electrifying effect that ever cheers, pleases and stimulates? There is one answer all will agree on—music.

Witness the hundreds of thousands of boys who have marched away from homes of comfort and love. Note their firm, manly steps, their erect bodies, swinging stride and smiling faces—and yet they are off to battle in a cruel, trying war; and still they are happy. No depression among them, nor among the thousands of mothers, fathers, brothers, sisters, sweethearts and friends. How do we explain it? Simply by the mysterious and undeniable power of music. They are inspired by the playing of the bands that lead them.

Nothing is so soothing, comforting and in-

spiriting as the strains of sweet music. It crowds sadness from the threshold, dispels gloom and distress and fills the soul with joy and hope.

Songs bring messages of affection, bravery and success. They arouse the finest spirit of fortitude and patriotism. Throughout the land they spread the gospel of liberty, and plant deep in the hearts of men and women, old and young, patience, courage, loyalty and the indomitable purpose of victory. The influence of song penetrates to the trenches themselves, and is welcomed eagerly by our wonderful boys there.

So, I say, give the people and the boys music; happy, lively, cheerful and soulful music. Keep them in good humor. Never let them for a moment at home or abroad give way to feelings of dejection. Under all and every circumstance hold up firmly and unflinchingly the "morale" of the people and the troops. Music will do it.

Every man who aids in the preparation and distribution of music is doing a patriotic work of great force and value.

MAKE DISPLAYS AT READING FAIR

READING, PA., October 4.—Several styles of talking machines were in evidence at the annual fair recently held in this city. The Metropolitan Phonograph Co. had a fine display and gave concerts at frequent intervals, while Arthur Wittich, the well-known piano dealer, had a very fine display of talking machines and pianos. They report many sales. The fair was attended by an enormous crowd from eastern Pennsylvania.

TO HANDLE THE AEOLIAN-VOCALION

The Griswold, Richmond & Glock Co., of Meriden, Conn., have made arrangements to represent the Aeolian-Vocalion phonograph, which is manufactured in that city. Arrangements are being made to give a series of free concerts at the company's store on West Main street.

A House-to-House Selling Campaign That Brought the Desired Results at a Low Cost

Methods of getting business that are successful are always interesting. R. L. Tamplin, the Columbia dealer at Windsor, Ont., tells how he operated a campaign of house-to-house calls that brought direct business at a minimum cost and that also netted him a live list of prospects. In his own words the plan is described as follows:

"A letter (reproduced below), together with the current record supplement and four records, were inclosed in the usual record container, and a start was made in the first street on the outskirts of the city. The distributor was instructed to first inquire if any instrument was in the house; if the answer was 'Yes,' a parcel was left with a few courteous words; if 'No,' a Grafonola catalog was left and a short talk given on the merits of the Columbia. No attempt to sell was made by the distributor—that part was left for the follow-up man. The name of anyone at all interested was obtained, both of machine owners and non-machine owners. The first point is important, it being a well-known fact that human nature in the mass is flattered by the implied importance of being known by name. On the following day I personally called to collect the records, not forgetting to address them by name. In practically every case I was invited in, and was able to interest them in my store and impress its location upon them. Even when no sale was made, by unflinching courtesy I made every effort to leave a favorable impression.

"The results of a month's trial of the scheme are as follows: First, an inventory for mailing purposes of every owner in the portion of the city worked, together with the tremendous future business possibilities of the personal touch. Second, \$832 of merchandise actually sold at a cost approximately of \$55.40 for distribution. Third, enough machine prospects to keep me employed for quite a little while. One other point is of interest—600 records were used in exploiting the scheme, and six only were damaged or apparently rendered unsalable. The returned records were carefully examined each day, cleaned and sent out again. The letters and containers also, if clean, were used over and over, thus keeping down the overhead."

The letter enclosed by Mr. Tamplin was as follows:

"Dear Sir or Madam: There can be no ques-

tion that more music is needed at this time. It is an indispensable food and tonic for your spirits. It is the greatest influence in the educational world. It enriches our whole lives. We are enthusiastic about Columbia records and anxious to have you hear them and judge them. Will you play the enclosed selections on your instrument? The records selected from

our latest lists are left with you on approval and you are under no obligation to purchase, but if you care to keep any or all, our salesman who will call to-morrow is empowered to receive payment and give a receipt. It would be a pleasure for us to supply you with any of the thousands of selections covered by the catalog enclosed herewith."

LARGER QUARTERS IN MACON, GA.

Williams-Guttenberger Music Co. Hold Formal Opening of Remodeled Store in That City

MACON, GA., October 2.—The Williams-Guttenberger Music Co. recently held a formal opening of their enlarged quarters at 168 Cotton avenue, this city, and celebrated the occasion in a most fitting manner. The company spent some thousands of dollars in enlarging and improving its store, and the result made an



New Home of Williams-Guttenberger Co.

excellent impression upon those who attended the opening.

The store has two entrances, each on a live street, one being at 168 Cotton avenue, and the other at 365 Second street. The store is 150 feet long by 19 feet wide, giving plenty of room for seven record demonstrating booths, a player roll booth, offices, telephone booth, etc. A balcony provides room for the main offices, and also display space for about twenty pianos, while the piano salesrooms proper are on the second floor. The company takes full advantage of display facilities offered by four large windows, two on each street.

The main floor, as indicated by the accompanying picture, is given over chiefly to the talk-

ing machine department, which is under the management of H. P. West, who reports a steady increase in business.

The officers of the company are: F. W. Williams, president; F. E. Williams, vice-president; C. N. Guttenberger, vice-president, and R. H. Williams, secretary and general manager. The progress made by the company is indicated by the fact that the staff has been increased from five to fourteen people within the short space of two years.

A HINT FOR NEXT SUMMER

Edison Dealer Used Novel Means of Attracting Attention This Past Summer

Arthur McPherson, of Bridgeton, N. J., knows how to make capital out of the romance of water and canoes and music on a summer night. He puts an Edison Army and Navy Model in the bow of a skiff and pilots it skilfully around the Bridgeton raceway, playing dreamy melodies. He is sure of a sympathetic audience, especially on moonlight nights. And he has taken care that his fellow-townsmen know the source of the romantic strains which float out over the waters to the listeners drifting about in canoes on the still water of the lake.

Is there a lake or river near your town? Try this plan next summer.

ENTERS THE SERVICE OF UNCLE SAM

L. A. Murray, of the L. A. Murray Co., Davenport, Ia., has just left for Camp Forrest. Mr. Murray conducts an exclusive Victor store in the Harned & Von Maur department store and the management is left in the hands of his sister, Miss Dorothy Murray.

"Reputation makes profit," therefore for reputation's sake handle goods of quality and reputation.

THE FOUNDATION IS RIGHT

Conditions have changed and are changing, but the principles back of the DITSON SERVICE remain steadfast.

The Victor dealer is entitled to the best service we can give him, and he gets it without qualification and regardless of conditions.

There's a Human Touch to Ditson Service That is Particularly Valuable Just Now

Oliver Ditson Co.
BOSTON

Victor Exclusively

Chas. H. Ditson & Co.
NEW YORK

Victrola IV-A, \$22.50
Oak

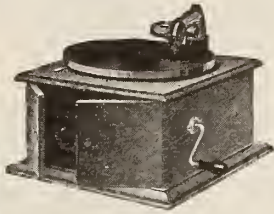

Victrola VIII-A, \$50
Oak

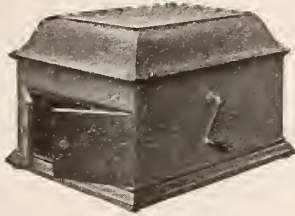

Victrola X-A, \$90
Mahogany or oak



Victrola XVI, \$225
Victrola XVI, electric, \$282.50,
Mahogany or oak

**“Will there be a
Victrola in your home
this Christmas?”**

That is the question which will again be put before the entire country through Victor advertising.

That is the question which is going to be settled in thousands of homes—and settled to your satisfaction.

So don't lose sight of the value to you of the Victor holiday advertising and “Will there be a Victrola in your home this Christmas?”

Victor Talking Machine Co.
Camden, N. J., U. S. A.

Berliner Gramophone Co., Montreal, Canadian Wholesalers

“Victrola” is the Registered Trade-mark of the Victor Talking Machine Company designating the products of this Company only.

Warning: The use of the word Victrola upon or in the promotion or sale of any other Talking Machine or Phonograph products is misleading and illegal.

Important Notice. Victor Records and Victor Machines are scientifically co-ordinated and synchronized in the processes of manufacture, and their use, one with the other, is absolutely essential to a perfect reproduction.



Victor Wholesalers

- Albany, N. Y.... Gately-Haire Co., Inc.
- Atlanta, Ga..... Elyea-Austell Co.
Phillips & Crew Piano Co.
- Austin, Tex..... The Talking Machine Co., of
Texas.
- Baltimore, Md.... Cohen & Hughes.
E. F. Droop & Sons Co.
H. R. Eisenbrandt Sons, Inc.
- Bangor, Me..... Andrews Music House Co.
- Birmingham, Ala. Talking Machine Co.
- Boston, Mass..... Oliver Ditson Co.
The Eastern Talking Machine
Co.
- Brooklyn, N. Y.... The M. Steinert & Sons Co.
- Brooklyn, N. Y.... American Talking Mch. Co.
G. T. Williams.
- Buffalo, N. Y..... W. D. & C. N. Andrews.
Neal, Clark & Neal Co.
- Burlington, Vt.... American Phonograph Co.
- Butte, Mont..... Orton Bros.
- Chicago, Ill..... Lyon & Healy.
The Rudolph Wurlitzer Co.
Chicago Talking Machine Co.
- Cincinnati, O..... The Rudolph Wurlitzer Co.
- Cleveland, O..... The W. H. Buescher & Sons
Co.
The Collister & Sayle Co.
The Eclipse Musical Co.
- Columbus, O..... The Perry B. Whitsit Co.
- Dallas, Tex..... Sanger Bros.
- Denver, Colo..... The Hext Music Co.
The Knight-Campbell Music
Co.

- Des Moines, Ia.... Mickel Bros. Co.
- Detroit, Mich..... Grinnell Bros.
- Elmira, N. Y..... Elmira Arms Co.
- El Paso, Tex..... W. G. Walz Co.
- Honolulu, T. H.... Bergstrom Music Co., Ltd.
- Houston, Tex..... Thos. Goggan & Bro.
- Indianapolis, Ind.. Stewart Talking Machine Co.
- Jacksonville, Fla.. Florida Talking Machine Co.
- Kansas City, Mo.. J. W. Jenkins Sons Music Co.
Schmelzer Arms Co.
- Lincoln, Nebr..... Ross P. Curtice Co.
- Little Rock, Ark.. O. K. Houck Piano Co.
- Los Angeles, Cal.. Sherman, Clay & Co.
- Memphis, Tenn... O. K. Houck Piano Co.
- Milwaukee, Wis... Badger Talking Machine Co.
- Minneapolis, Minn. Beckwith, O'Neill Co.
- Mobile, Ala..... Wm. H. Reynolds.
- Montreal, Can.... Berliner Gramophone Co.,
Ltd.
- Nashville, Tenn... O. K. Houck Piano Co.
- Newark, N. J..... Price Talking Machine Co.
- New Haven, Conn. The Horton-Gallo-Creamer Co.
- New Orleans, La... Philip Werlein, Ltd.
- New York, N. Y.... Blackman Talking Mach. Co.
Emanuel Blout.
C. Bruno & Son, Inc.
I. Davega, Jr., Inc.
S. B. Davega Co.
Charles H. Ditson & Co.
Landy Bros., Inc.
New York Talking Mach. Co.
Ormes, Inc.
Silas E. Pearsall Co.

- Omaha, Nebr..... A. Hospe Co.
Mickel Bros. Co.
- Peoria, Ill..... Putnam-Page Co., Inc.
- Philadelphia, Pa.. Louis Bucher Co., Inc.
C. J. Heppie.
The George D. Ornstein Co.
Penn Phonograph Co., Inc.
The Talking Machine Co.
H. A. Weymann & Son, Inc.
- Pittsburgh, Pa.... W. F. Frederick Piano Co.
C. C. Mellor Co., Ltd.
Standard Talking Machine Co.
- Portland, Me..... Cressey & Allen, Inc.
- Portland, Ore..... Sherman, Clay & Co.
- Providence, R. I... J. Samuels & Bro., Inc.
- Richmond, Va..... The Corley Co., Inc.
W. D. Moses & Co.
- Rochester, N. Y... E. J. Chapman.
The Talking Machine Co.
- Salt Lake City, U. Consolidated Music Co.
The John Elliott Clark Co.
- San Antonio, Tex. Thos. Goggan & Bros.
- San Francisco, Cal. Sherman, Clay & Co.
- Seattle, Wash..... Sherman, Clay & Co.
- Sioux Falls, S. D.. Talking Machine Exchange.
- Spokane, Wash... Sherman, Clay & Co.
- St. Louis, Mo..... Koerber-Brenner Music Co.
- St. Paul, Minn.... W. J. Dyer & Bro.
- Syracuse, N. Y.... W. D. Andrews Co.
- Toledo, O..... The Whitney & Currier Co.
- Washington, D. C. Cohen & Hughes.
E. F. Droop & Sons Co.
Roht. C. Rogers Co.

AN IMPORTANT ACCESSORY—ALBUMS FOR FILING DISC RECORDS

The enormous demand for "National" Record Albums keeps apace with the ever increasing demand for machines and records, and our output capacity has been enlarged to meet the greater needed supply. Record Albums have proven themselves to be the best and most convenient, as well as economic, method of filing and keeping disc records.



MAKING THEIR SELECTION

Illustrating the daily actual usage of the Album, the most convenient and satisfactory record filing system extant.

THE ALBUM

soon pays for itself in time-saving and preserving records. The initial cost is really an investment which comes back fourfold.

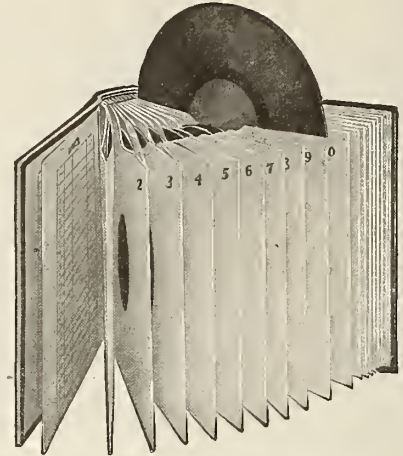

THE PERFECT PLAN

The pockets holding the records are substantially made from strong fibre stock, firmly joined together and bound in attractive covers.

A PLACE FOR EVERY RECORD AND EVERY RECORD IN ITS PLACE

Albums are an **Indispensable Requisite** in the talking machine business and wherever records are sold. An accessory that is necessary and worth while. Practical and handy. Save time and records. A profitable adjunct to the business. All owners of machines and records want Albums to file and preserve their records.

We manufacture disc Record Albums containing 12 pockets to fit cabinets of all sizes and styles. We also make Albums containing 17 pockets. With the indexes they are a complete system for filing all disc records.

For durability, finish and artistic design, our Albums are unsurpassed. We have unexcelled manufacturing facilities, and considering quality our prices are the lowest. Write us, giving quantity you may desire, and we will quote prices.

OUR ALBUMS ARE MADE TO CONTAIN VICTOR, COLUMBIA, EDISON, PATHÉ AND ALL OTHER DISC RECORDS

NATIONAL PUBLISHING CO. : 239 S. American Street : PHILADELPHIA, PA.

COLORADO SPRINGS IDEAL CITY FOR TALKING MACHINES

At Least So the Dealers Declare—Tourist Business Keeps Up Well—New Edison Shop Piling Up Sales Total—J. D. Falkenburg in Charge of Knight-Campbell Department

COLORADO SPRINGS, COLO., October 1.—Marked activity was noted on all sides in the talking machine trade in Colorado Springs the past summer. The tourist season was a very good one despite the high rates for railroad fare and the fact that transportation facilities were not as good as in former seasons. However, all of the talking machine dealers commented on the fact that their trade was good and that their customers were gradually increasing. J. D. Falkenburg, manager of the Victrola department of the Knight-Campbell Music Co., said: "We find that this has been one of our busiest seasons and that our sales of Victrolas and Victor records have shown a marked increase over the summer season of 1917." Mr. Falkenburg was formerly located at Albuquerque, N. M., and is now taking the place of Lieut. Davis Allen, who is in the United States service. Mr. Falkenburg is very enthusiastic over the Victor school room system of educational work and stated that Victrolas had been installed in all of the schools of the city and that he was directing the attention of the public to the use

of Victrolas in the public playgrounds, having given a series of Victrola concerts which were keenly enjoyed by the little folks. Miss Mary M. Burnap is the able assistant to Mr. Falkenburg.

Mrs. E. G. Paster maintains an exclusive shop for Victrolas at 22 East Kiowa street, and stated to The World representative that "Colorado Springs was an ideal town for the Victrola." Her demonstration rooms are attractively fitted up. She is a great believer in judicious advertising and has excellent results from it.

J. D. Hiltbrand and the Hext Music Co. also handle the Victrola and inquiries there elicited the information that sales were brisk.

The Grafonola Shop, under the management of Alexander McIntosh, located at 21 East Kiowa street, is admirably fitted up with a number of demonstration rooms and show-rooms for the display of the Columbia products. Mr. McIntosh is very sanguine regarding the future of the Grafonola in Colorado Springs and is anticipating a good fall and winter trade.

The New Edison Shop is located on Pike's

Peak avenue within easy access of the business center of the city. Kenneth and Lieut. H. M. Wyckoff are the proprietors. The latter is now with the colors. Kenneth Wyckoff stated that the firm was building up a large and constantly increasing trade and incidentally mentioned that over \$20,000 worth of sales had been made since the shop had been opened, it being comparatively new in Colorado Springs. The interior of the shop is tastily fitted up and can be utilized for a recital hall should the occasion require.

The Peerless Furniture Co. are the sales agents in Colorado Springs for the Brunswick phonograph. Manager Bloom, of the company, is looking for a brisk season this fall.

ELECT OFFICERS IN CEDAR RAPIDS

The Music Dealers' Association of Iowa, Recently Organized, Elect Officers for the Ensuing Year—Discuss Matters of Interest

The Cedar Rapids Music Dealers' Association of Iowa have just elected officers for the coming year, which are: President, J. J. Kuncel, of the Kuncel Co.; secretary, F. H. Garner, manager of the Geo. A. Mullin Victrola department; treasurer, F. W. Slapnicka, of the Slapnicka Music Co. The members are F. C. Miller, H. C. Waite, F. H. Drew, C. K. Emerson, E. B. Hiltbrunner, A. H. Niles, W. E. Dewell, B. D. Jansa, W. O. Stepanek, W. A. McNaughton and J. F. Miller. The association has been organized for several months and is having wonderful success as to the regulation of records on approval, time payments, etc. It has the co-operation of the Cedar Rapids Chamber of Commerce, and is represented at all of its meetings.

Thomas A. Edison made the very happy suggestion recently in connection with the Fourth Liberty Loan that business men in all their letters should put above their signatures a phrase somewhat like "Yours for the success of the Fourth Liberty Loan," or other words that will keep before the reader the importance and pertinence of subscribing to the Loan.



Style 900

THE REGINAPHONE

A phonograph of the highest grade with many exclusive features. The new Regina Sound-box is the greatest improvement in talking machines in years, reproducing all hill and dale and lateral cut records equally well, and in a manner unsurpassed.

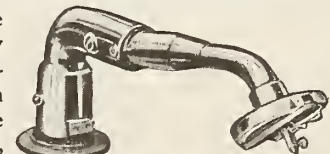

New Regina Sound-Box

Territory arrangements with active dealers. Send for particulars.

THE REGINA CO.

Manufacturers of the Regina Music Box and other musical instruments for over 25 years.

47 West 34th Street, NEW YORK
209 S. Wabash Ave., CHICAGO, ILL.

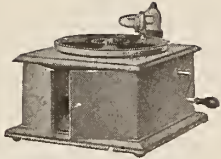

Victrola IV-A, \$22.50
Oak



Victrola VI-A, \$32.50
Oak



Victrola VIII-A, \$50
Oak



Victrola IX-A, \$60
Mahogany or oak



Victrola X-A, \$90
Mahogany or oak



Victrola XI-A, \$115
Mahogany or oak

Victor Supremacy

—all the time
and everywhere

Viewed from the standpoint of musical art, judged by the character and prestige of the stores that handle it, measured in dollars for its ability as a profit producer, the Victrola is supreme.



Victrola XIV, \$175
Mahogany or oak



Victrola XVI, \$225
Victrola XVI, electric, \$282.50
Mahogany or oak



Victrola XVII, \$275
Victrola XVII, electric, \$332.50
Mahogany or oak

Victor Talking Machine Co.
Camden, N. J., U. S. A.

Berliner Gramophone Co., Montreal, Canadian Wholesalers

"Victrola" is the Registered Trade-mark of the Victor Talking Machine Company designating the products of this Company only.

Warning: The use of the word Victrola upon or in the promotion or sale of any other Talking Machine or Phonograph products is misleading and illegal

Important Notice. Victor Records and Victor Machines are scientifically co-ordinated and synchronized in the processes of manufacture, and their use, one with the other, is absolutely essential to a perfect reproduction.



"HIS MASTER'S VOICE"

REG. U.S. PAT. OFF.

The TALKING MACHINE WORLD

For the makers & sellers of talking machines

PUBLISHED BY EDWARD LYMAN BILL, Inc.

President and Treasurer, C. L. Bill, 373 Fourth Ave., New York; Vice-President, J. B. Spillane, 373 Fourth Ave., New York; Second Vice-President, J. Raymond Bill, 373 Fourth Ave., New York; Assistant Treasurer, Wm. A. Low.

J. B. SPILLANE, Editor

J. RAYMOND BILL, Associate Editor

Trade Representatives: B. BRITAIN WILSON, L. M. ROBINSON, WILSON D. BUSH, C. CHACE, V. D. WALSH, E. B. MUNCH, L. E. BOWERS, A. J. NICKLIN

Boston: JOHN H. WILSON, 324 Washington Street

Chicago Office: E. P. VAN HARLINGEN, Republic Building, 209 South State Street. Telephone, Wabash 5774

London, Eng., Office: 2 Gresham Buildings, Basinghall St. W. LIONEL STURDY, Mgr.
The Talking Machine World has regular correspondents located in all of the principal cities throughout America.

Published the 15th of every month at 373 Fourth Ave., New York.

SUBSCRIPTION (including postage): United States, Mexico, \$2.00 per Year; Canada, \$2.25; all other countries, \$3.75. Single copies, 25 cents.

ADVERTISEMENTS: \$4.50 per inch, single column, per insertion. On quarterly or yearly contracts a special discount is allowed. Advertising pages, \$125.00.

REMITTANCES should be made payable to Edward Lyman Bill, Inc., by check or Post Office Money Order.

NOTICE TO ADVERTISERS.—Advertising copy should reach this office by the first of each month. By following this rule clients will greatly facilitate work at the publication headquarters.

Long Distance Telephones—Numbers 5982-5983 Madison Sq.
Cable Address: "Elbill," New York.

NEW YORK, OCTOBER 15, 1918

PROBABLY there is no industry of its size that will be so seriously affected by the workings of the new Draft Law as the talking machine industry, for it is essentially an industry of young men—men who entered the new field as youths.

There are, of course, very many men over forty-five in the trade, but they are far in the minority. In fact, the average age of the members of the trade, as calculated by an observance of those who attend the various meetings, might well be fixed at something between thirty and thirty-six or seven.

Of course, it will rest with the various local draft boards as to how seriously the ranks of the employes in the trade are depleted to build up the nation's man power for war work, and it is to be presumed that the executive forces will be dealt with leniently in this respect. It must be expected, however, that the sales staffs are going to be hit, particularly in certain sections, if the workings of the first draft are to be accepted as any criterion. It means that the various concerns must give serious study to the conservation of the man power that is left to them, through the rearrangement of work and the instalment of more efficiency generally where possible.

There must also be considered the more general employment of women, whose work in the trade, particularly as members of the selling forces, and even in managerial capacities, has progressed considerably beyond the experimental stage. Of course, with less goods to sell, wholesalers and retailers can get along with considerably reduced staffs, but at the same time the first draft, together with enlistments and the entrance of employes into direct war work, has made inroads that have more than offset the decreased necessity for help. The "work or fight" provision of the new Draft Law simply adds one more problem to the many that are facing the members of the industry right at the present time.

THE War Service Committee of the talking machine industry, and particularly its chairman, H. L. Willson, are to be congratulated upon the success of their efforts in representing the industry as a whole in various important matters before the authorities in Washington. The working of the committee is all the more remarkable in that it had no basis to start work on—no organization from which to draw support, but was the child of a hurried meeting, and sprang into activity almost overnight.

Urged on more than one occasion to form a definite organization the talking machine manufacturers for one reason or another hesitated until the time came when it was almost a case of organize or disintegrate. The rapidity with which the manufacturers came together—decided upon their plan of campaign—and organized their committee, will afford some idea of the excellent work that might have been done had a definite general organization been formed when there was time for a leisurely and careful building up of the association fabric. Once appointed the committee moved with a rapidity and assurance that left little to be desired.

It was found that individual members of the industry, or groups of members, were unable to secure recognition in Washington, unless they came as representatives of the entire industry. It was also found that duly authorized representatives could expect little attention unless they were prepared to submit facts, and not surmises, regarding the extent of the industry, its output and its requirements.

The committee first secured the support of the industry as a whole, and next secured the recognition of the Chamber of Commerce of the United States, and finally the Government officials. Next came the question of compiling statistics regarding the industry, a monumental task under ordinary circumstances, but one that was handled quickly under the spur of wartime necessity. In the matter of curtailment of output, as well as in the matter of steel and iron supply, the committee has accomplished really remarkable work, especially when there are considered the conditions under which its members were forced to labor.

If these trying times have done nothing else, they have at least brought the producing elements of the talking machine trade together on a common footing, and have brought forth the figures regarding production, invested capital and other vital matters that have occasioned surprise even to those who considered themselves well acquainted with the industry and its scope.

Having come together in an emergency the talking machine and supply manufacturers should find it a comparatively easy matter to effect some sort of permanent organization that will be able to handle trade problems in peace, as well as in war-times—an association that will tend to weld the various interests of the trade into one common whole for offensive and defensive purposes.

It took pressing danger to bring the members of the trade together. It seems folly to assume that a separation will occur after this particular time of trial has passed. The future holds much for the talking machine industry, and many of its opportunities can best be realized upon through organization. Stick together!

IT is a noteworthy fact that despite wartime conditions and the problems they present for the consideration of talking machine manufacturers generally, there has been no slackening in the efforts to develop both machines and records to a higher degree of perfection whenever such results are possible. During the past few months there have been introduced to the trade numerous new models of machines, improved reproducing devices and new types of records, all designed to mark a general development in the art. In other words, talking machine manufacturers, unlike the manufacturers of some other lines, have not stopped to mark time and see what is going to happen, but have kept going ahead. The result will be that when peace times come again the talking machine trade will have shown distinct development over pre-war standards, and will be better equipped than ever to profit by that foresight.

THE great Liberty Loan rally at Carnegie Hall on the evening of September 30 was without question one of the greatest, if not the greatest, musical program of its kind ever staged. Think of Galli-Curci, Caruso, McCormack and Heifetz, to say nothing of Pryor's Band, all on one stage for one concert. This galaxy of artists, whose combined appearance at their regular rates would command a price that would put a noticeable dent in the bankroll of a Rockefeller, might be said to be distinctly representative of the part taken by the talking machine interests in the local Liberty Loan drive of the Allied Music Trades. It

was through the efforts of those interests that the artists consented to appear, although credit must be given to the Victor Talking Machine Co. directly for paying the transportation and other expenses of Pryor's Band as a part of that company's contribution. Surely the talking machine industry and everyone in it can feel pride in the showing made, for it is these artists, whose names have been made household words, largely through the medium of the talking machine, that drew an audience to Carnegie Hall that filled every nook and cranny of that great auditorium, and resulted in an immense sum being subscribed for bonds to back up the good work being accomplished by the American army at the front.

SERIOUS consideration is being given by business men in all lines of industry to the development of export trade, not only now, but especially after the war. The past month forty-four manufacturers whose domestic sales aggregate annually one hundred million dollars came together in New York and formed a combination to develop foreign trade, to be known as the Allied Industries Corp. This is one of the first important moves showing co-operative effort in the matter of export trade, which is permitted under the Webb-Pomerene bill, which recently became a law.

We have not yet as a nation fully realized the opportunity which is now opening for American trade in foreign countries. The demand is literally world-wide, and is bound to increase naturally after the close of the war. The dullest mind must be stirred by the possibilities of expansion and development throughout the whole field of industrial activity.

To attain any measure of success in the exports of musical instruments or any other products co-operative effort is most essential, and manufacturers must work along constructive lines in this matter. They must get together and plan unitedly, not only to hold markets to which they are now sending musical instruments, but must create and perfect new avenues which will insure trade being developed when world competition is again supreme.

Business men to-day are facing a great many annoyances and interruptions to the development of their plans, but it is not a time for pessimism—not a time to sit down and bewail their lot, but rather is it the time for careful, deliberate planning of business advance along new lines at home and abroad. American business sagacity is on trial as never before, and if we merely assume a passive attitude and do nothing constructive we will arrive nowhere.

In the talking machine industry, as in other lines, there is a gratifying tendency among manufacturers to get together for a common interchange of thought upon the needs of the industry. Old-time prejudices have been dissipated and common sense

rules. This is certainly a most helpful sign, and it means much for the inauguration of a successful policy in the matter of supplying export demands. We can only do a limited export trade to-day. We haven't the goods. It is the future that we must keep in mind, for, as Edward N. Hurley points out, we must perfect such business plans as will enable us to utilize our great merchant marine after the war.

OF great interest to the talking machine trade throughout the country is the letter recently sent out by Louis F. Geissler, general manager of the Victor Talking Machine Co., in which he tells in detail of the position in which the Victor Co. finds itself on account of the demands made on its manufacturing resources on account of war work. It is a frank and honest statement which, from the viewpoint of the talking machine trade, is tinged with optimism, because it holds out hope for at least a modest supply of Victor goods until such time as the war comes to an end, which, judging from recent developments in Bulgaria and on the Western Front, may not be as long off as the wise ones originally estimated. In this letter Mr. Geissler says: "We have no doubt that we shall be able to continue the manufacture of machines and records in fully as large a proportion to our last year's business as any other manufacturer can hope to do."

Mr. Geissler emphasized a most important matter in this communication when he said: "In this connection it will be interesting to you to know that responsible administrative officers of the Government have expressed themselves as regarding our products as 'prime necessities of peace times, and very important to the welfare of the country in wartimes.' We are confident that the talking machine industry will not be unnecessarily discriminated against by the Government, but that its activities will be encouraged to the limit that can be done without interference with the production of ships, aeroplanes, rifles, ammunitions, and the other prime necessities of warfare."

ARE the business men of America to hold aloof when being called upon to lend their assistance in creating that class of credit instruments which is eligible above all others for purchase and rediscount by the Federal Reserve Banks? asks J. H. Tregoe, secretary of the National Association of Credit Men. Present conditions point to the un wisdom of using other paths than those indicated by the highest authorities as safest. Keep your business as liquid as circumstances will permit. By so doing you are in the best possible position to meet emergencies or sudden contingencies. The acceptance method—the method by which one indicates that his borrowings are based on the actual movement of merchandise—is the method of highest safety, because it substitutes liquid instruments for frozen accounts. It is the part of wisdom to adopt it.



SERVICE THAT BUILDS CONFIDENCE

We work for and with the Victor Dealer both in supplying him with Victrolas and records and in helping him sell them to best advantage. Our interest in a machine or record ends only when it is in the home of the customer, and we try to help the dealer place it there. Our dealers' confidence in us makes this possible. We're partners to that extent.

ECLIPSE MUSICAL CO.
CLEVELAND OHIO



JOSEPH PENNELL DEL.

THAT LIBERTY SHALL NOT PERISH FROM THE EARTH

**BUY LIBERTY BONDS
FOURTH LIBERTY LOAN**



**Lend the way they fight
Buy bonds to your utmost**

This page contributed by the



BRILLIANTONE STEEL NEEDLE CO. OF AMERICA INCORPORATED

Suite 655-657-659 Marbridge Building, Broadway at 34th Street

B. R. FORSTER, President



NEW YORK CITY

Why the Dealer Should Make His Talking Machine Department Attractive :: By J. W. Methune

Every dealer, it matters not whether he be an exclusive dealer or simply one who handles talking machines and records as a side issue, wants to increase his trade. This is the most natural thing in the world. He hopes to do this, but at times is at a loss to proceed along lines that might be called intelligent and that demand more than a commonplace effort. Can he hope to enjoy all the trade that he wants when his department or his store does not attract? Therein lies one of the real secrets for success or for its opposite.

The public might be aware of the store or the department that does cater to their wants in the sale of machines and records, but that does not signify that this fact—a mere incident—is going to act as a reason or as an argument for the prospective customer to enter and to make a purchase. The reason for this lies in a deeper and more well-founded argument. They want to be given an extra reason for seeking your store. They want to find therein a striking argument in order to induce many of them to come to you, and to pass by the other man whose place of business is nearer to them.

What is the reason if not the store that is attractive? Not alone the store, but also the department itself? Here is where the public is going to come, and where the sales are going to be made. If you can offer an inducement in this way, well, then, you can count it an argument and one that will prove its logic.

What would you deem an attractive store or department? What would appeal to you in the other man's store? Would you, if the store did not appeal to you, enter when there was another up the street that did? You would go farther and enjoy this added pleasure, and you would not feel that you had done other than the proper thing. Why then hope for the trade when there is so little incentive?

Now the store or the department that does appeal is that which teems with a life that can be made so apparent to the casual beholder. The stock is arranged in a way that will show it off to the best advantage. If there are shabby booths, and if the machines are badly displayed, and the records stored out of sight or badly arranged, how can this possibly appeal to the best class of trade? It does not. The better class of customers do not even hope to find that which will appeal to them here and they go elsewhere.

Make your talking machine department attractive. Make it alive, make it fairly teem with life. Have the talking machines placed in the best possible location to invite inspection. Keep them in trim. Make them look like new machines, not like an old stock-worn device or something that is only fit for the junk pile. Can this appeal? Does it appeal to you? No. It has its contrary effect, and the would-be prospect turns aside and seeks the store that gives this subject all the attention that it so well merits.

Where are your booths? Are they easy of access? Are they well lighted, airy, clean and fitted with a good machine and easy chairs? Does the prospective customer come here to be entertained or to be bored with all that is uninviting? There is the double opportunity here to make sales of both machines and records. But there must be an inviting appearance to bring this to mind. If the booths do not appeal then the customer is not imbued with the idea of making a purchase. These must be above the ordinary type to attract and to hold the public's attention.

Where are the records? In the front of your store, convenient to the booths, or located so that the salesman has to dig into the waste and dirt to pull them out? Are they so arranged that he can get to them without the annoyance

of a long wait? If there is a lack of this system the customers turn away with a feeling of disgust. They are looking for service. This is not service and the poor substitute is not going to help make sales.

Have you attractive signs about that tell of

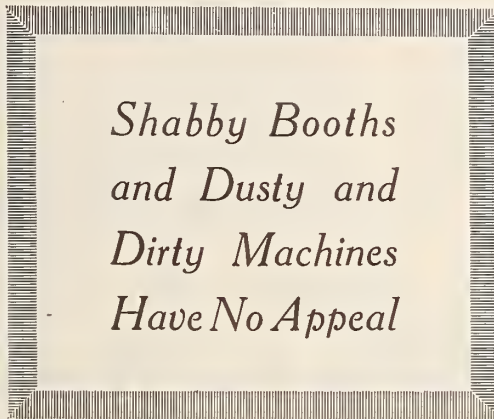

*Shabby Booths
and Dusty and
Dirty Machines
Have No Appeal*

the latest popular hits, and of the new and timely records that are just now all the rage? Can you in this way offer a hint and a helpful idea

ADOPT RECORD APPROVAL PLAN

Talking Machine Dealers of Des Moines Make Important Move in This Direction—G. E. Mickel Returns From Eastern Trip

DES MOINES, IA., October 3.—The talking machine dealers of this city, including Chase & West, S. Davidson Bros. Co., Haddorff Music Co., Heggen Furniture Co., Chapman Furniture Co. and the Ginsberg Furniture Co., have lately adopted a thirty-six-hour record approval plan on all records and of which one-third of the selection sent the customers must be purchased. All dealers report very good success so far. "This new plan," said Mr. Chase, "is bringing many people into the store who have never come before and our sales are as high as ever."

Geo. E. Mickel, general manager of Mickel Bros. Co., Des Moines, Ia., and Omaha, Neb., has just returned from a trip to the Victor fac-

tory. He also attended the meeting of the executive committee of the National Talking Machine Jobbers' Association during his visit.

When we understand that the talking machine store or department should be rather in the nature of a parlor, with the homelike atmosphere, then we come to a full realization of the part that is to be played by the man who is seeking to make sales in an intelligent manner. Selling talking machines and records is not like selling dry goods. There must be a different atmosphere. The would-be customers want to see this "homy" air about the store. They are looking for it. They want to be entertained, and it is hard to be entertained in a store that is lacking in this essential. It cannot appeal to the trade that you want to seek. It never will do so.

You must make your talking machine department a different place. You must make it a haven for the tired shopper—for the shopper who is not tired, but who nevertheless enjoys that feeling of restfulness and that comfy feeling that makes the music or the story so much more delightful.

W. F. Fries, Iowa traveler for the Victor Co., called on Mickel Bros., Des Moines, Ia., recently. Mr. Fries has established a home in Mason City, Ia., for Mrs. Fries and young "Bill" and will use this point as his headquarters for this season. Another caller was Mark W. Duncan, of Albia, Ia., who was on his way to Hot Springs for a vacation.

MANAGING LOHR & BRISTOL STORE

Robt. A. Nietzel has taken over the management of the Lohr & Bristol store in Muscatine, Ia., as both the owners have entered the service of Uncle Sam. Miles E. Bristol has just left for Camp Forrest, and Ralph G. Lohr is with one of the Aero Construction Squads in Oregon. This concern conducts an exclusive Victrola store.

OVERCOME THE STEEL SPRING SHORTAGE

BY USING

VEECO MOTORS

THE ELECTRIC WAY

The improved VEECO electric motor is designed primarily and exclusively for Talking Machines. It is smooth and noiseless in action and practically fool-proof. Standard models run on any voltage from 100-125, A. C. or D. C., without adjustment. Other models for any voltage from 6-250. Furnished mounted on 12 or 12½ inch mahogany board ready to install, or without board, all ready to mount on such board as used by the manufacturer.

With the VITRALOID turntable, supplied with the motor, it makes a complete motor unit for high class machines.

Send for a sample NOW and place your order at once for early fall delivery.

THE VEECO COMPANY

248 Boylston St.

Boston, Mass.

THE ORIGINAL PRODUCERS OF A COMPLETE ELECTRIC DRIVE
FOR TALKING MACHINE MANUFACTURERS' USE

Edison Message No. 29

General Pershing Wants Our Army Bands to Be the Best in the World

Walter Damrosch dined with General Pershing at the American General Headquarters in France only a few days before the recent big offensive at the Marne. Said Pershing, "I would like our army bands to play so well that when we march up Fifth Avenue after peace has come people will say 'Here is another proof of the justice of military training.'" During all the dinner our commanding general spoke not a word of battles—only of music.

Edison dealers will find in this incident just another proof of the essentialness of music to the war. And what is true of the firing line is doubly true here at home. The Edison dealer who talks "not of battles, only of music" stands squarely on his platform as a worker "for the welfare of the people."

THOMAS A. EDISON, Inc.

Orange, N. J.

The Application of Period Decoration to Talking Machine Cabinets—The Adam Style

Period models of talking machines are now plentiful enough to take them out of the novelty class. During the past year or two the trade has been treated to an interesting display of period models of various types of machines, vying with each other in elaborateness of design, and intended to place the talking machine, already recognized as a musical instrument of the highest type, well up in the list as a decorative adjunct to the home.

The introduction of the period model is to be accepted as a logical outgrowth, the machine itself having reached a high point of development, permitting of the paying of more attention to its housing. Period models are not to be made and sold simply because they are period models, for that in itself means nothing. The ordinary talking machine cabinet of other days placed in a Louis XVI room, for instance, might not harmonize with the general decorative scheme, but is nevertheless recognized as a talking machine and, therefore, excused on that account. When encased in a Louis XVI cabinet, however, the machine becomes an ambitious piece of furniture, as well as a musical instrument, and is to be regarded from both angles. This point must be remembered both in making and selling period styles, so that in the designing thereof a full appreciation must be had of what is being attempted and what it is desired to accomplish.

Period cabinets are either good or bad. There is no medium. Either they follow the design of the period closely and fit in well with the other furnishings of that period, or they display a lack of knowledge of the basis of period decoration and the ideals back of it, and simply serve to jar the artistic sense. Period designs should not be attempted in a haphazard manner, for faithfulness of detail is the secret of successful work along that line. A brass wreath with the letter "N" in the center attached to a cabinet does not stamp it as an Empire Style, neither does a bit of marquetry inserted at random mark it as distinctly Sheraton. In other words, one detail does not make up a period reproduction, but the whole thought must be in strict accord with the ideas of the master designer, or designers, whose style it is desired to reproduce.

We observe, for instance, that a number of designers of talking machine cabinets are admirers of the Hepplewhite style and endeavor, some of them with success, to adopt that style for talking machine cabinets. It must be remembered that with the ordinary square-cornered cabinet the adoption of these ideas would be a rather difficult task, but inasmuch as originality is now being displayed in the creation of talking machine cabinets, greater opportunities are presented to the designer to follow the lead of the masters most effectively through copying with some exactness actual models of their work. The master designers themselves frequently fail to follow definite styles in their work, although there are certain ideas predominating in the various designs that might be described as key motifs, and which gave a characteristic touch that identified the work of the individual.

An endeavor will be made in these columns to set forth some of the characteristics of the work of the most famous furniture designers, which, together with illustrations of some other authentic pieces, will serve to give the designers of the day a definite idea of the details going to make up any particular style.

Perhaps the most familiar decorative style of the average American is the Colonial, and this style can be traced directly to the work of Robert and James Adam, the English furniture designers of the middle eighteenth century. The brothers Adam in all their work showed a strong

trend toward simplicity—a simplicity that has made our own Colonial style so popular and so lasting. The Colonial style is a Greek derivative, and the Adam brothers never understood anything but the purely classic. Finally, there is hardly a detail in our Colonial houses that

work resembles the Louis XVI and Empire styles of France, this despite the fact that the Louis XVI style was not created until 1774, twenty years after Robert Adam began his work in England, and the Empire style was not created until 1804, twelve years after Robert Adam's death.

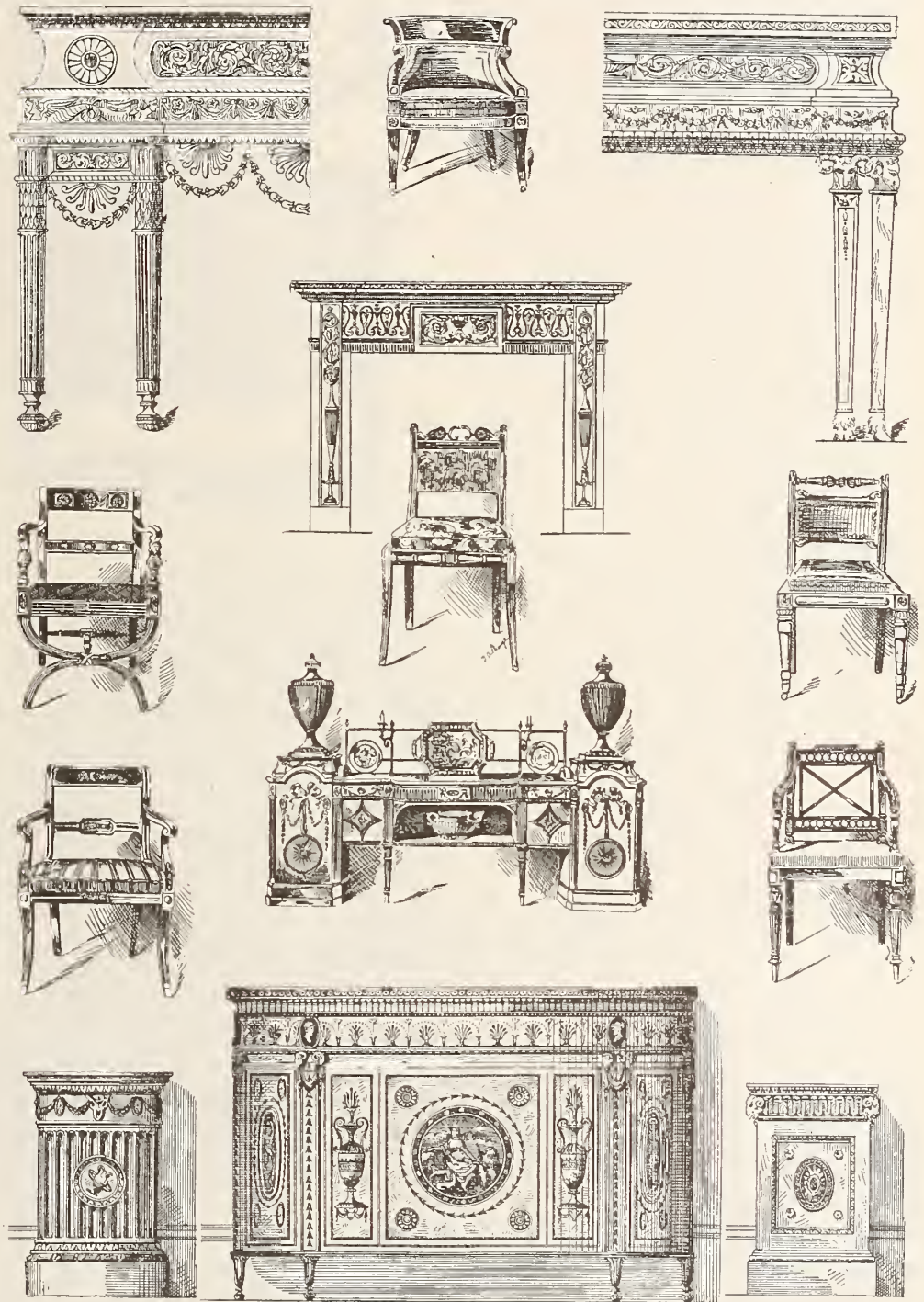

Some Dominating Details of the Adam Style

cannot be found in the Adam style in the same form. Moreover, Colonial furniture, with its highboys, its commodes and its chests of drawers, presents outlines that can be easily reproduced with success for housing talking machines.

To appreciate the greatness of the brothers Adam, it must be remembered how closely their

work resembles the Louis XVI and Empire styles of France, this despite the fact that the Louis XVI style was not created until 1774, twenty years after Robert Adam began his work in England, and the Empire style was not created until 1804, twelve years after Robert Adam's death.

(Continued on page 14)

Talking Machine Hardware

We manufacture hardware for all styles of cabinets

Lid Supports	Door Catches	Sockets
Needle Cups	Sliding Casters	Tone Rods
Needle Rests	Continuous Hinges	Knobs, etc.

BEST QUALITY LOWEST PRICES

WEBER-KNAPP COMPANY - Jamestown, N. Y.

APPLICATION OF DECORATIVE ART
(Continued from page 13)

The brothers introduced into England the use of composition ornaments applied to wood-work. Their decoration was generally in low relief. They used all the Greek details, nearly all of the Roman, and a few Renaissance scrolls. Neatness and chastity were the prevailing features. Mahogany was used almost exclusively, but toward the end of the century they used satinwood for inlays. Tables and sideboards frequently had inlaid tops, while sofas and other heavy pieces of mahogany were fitted with brass mounts. In their work the brothers had the help of some of the greatest artists of the day, Cipriani, Pergolesi, Angelica Kaufmann and others, who did beautiful work in inlay, painted panels, etc. The Adam style can be summed up in a few words. It was a light and simple classic style, with low relief, delicate slenderness of detail, and Greek grace marking every feature. If a thing was in itself massive, the Adam style covered it with delicate details until it was apparently light and graceful. Sheraton and Hepplewhite both acknowledge their indebtedness to the Brothers Adam, for both drew their charming simplicity from their work.

Some of the details of the Adam style included: acanthus, circles, cupids, caryatides, draped figures, eagles' claws, eagles, egg and dart moulding, festoons, fauns, frets, fan shapes, griffons, garlands, goats, grotesques, hexagons, honeysuckles, husks, lozenges, lions, lion claws, lunettes, medallions, octagons, ovals, ox skulls, paterae, panels, rosettes, ribbons, rams' heads, scrolls, sphinx, triglyphs, tooth mouldings, urns, wreaths, and wave bands.

The plate shown on page 13 illustrates most excellently the more important details of the Adam style, applicable to various forms of furniture and decoration.

Every dollar you put into the Liberty Loan you save twice—you save it for the country and you save it for yourself.

NEW SERIES OF LANTERN SLIDES FOR EDISON DEALERS

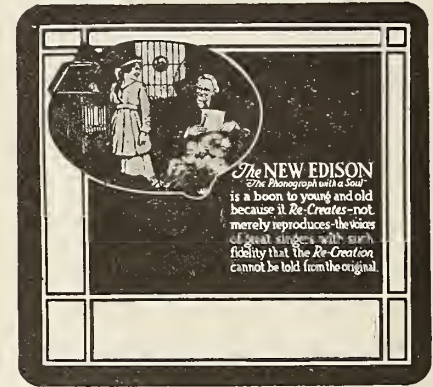
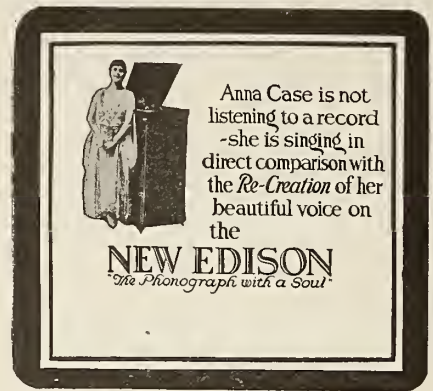

Herewith Are Shown Four of a Series of Six New Lantern Slides Prepared for the Use of Dealers by Thomas A. Edison, Inc., Which May Be Ordered From Jobbers at a Price of 25 Cents Each

LIEUT. OLSON CONVALESCING

Lieut. Arthur J. Olson, formerly Western sales manager of Jones-Motrola, Inc., New York City, has been wounded in action and is convalescing in a base hospital in Southern France. He was wounded by a bomb explosion on

August 8 while taking his troops across a bridge. In his latest letter he states that he is steadily improving and expects soon to get back to the front. He is in an American hospital run by the University of Pennsylvania. Lieutenant Olson has a good many friends in the trade who will be glad to learn of his convalescence.

**The Arrow Points in Both Directions
If You Have the Eject-O-File in Stock**

**Profits
on
Machine
Sale**

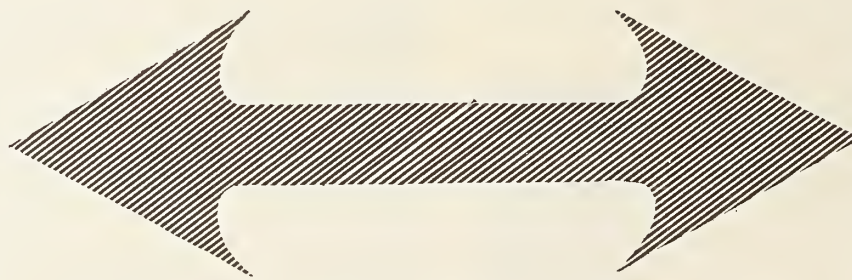

**Profits
on
Eject-O-File
Sale**

The many advantages of this highly efficient record filing device, that produces the record wanted at the touch of a finger, are so pronounced that sales are easily made

Eject-O-Files are built to fit: COLUMBIA Style 75. VOCALION Styles F, G, H, I, J, K, and EDISON Styles C150 and 100

Retails at \$10. In beautiful oak or mahogany finish. Polished, wax or dull finish. Write for descriptive circular and details so that you may see the opportunities this line holds for you.

EJECT-O-FILE SALES CO.

216 W. SARATOGA STREET



BALTIMORE, MD.

Make your windows work! That's one way you can meet the rising cost-of-doing-business.

**Columbia Graphophone Co.
NEW YORK**



NO REASON FOR VIEWING THE FUTURE WITH ALARM

Illuminating Analysis of Conditions in the Talking Machine Industry by Ernest Urchs—Importance of Maintaining One-Price Principle—Tribute to the Policies of Victor Co.

In answer to the question "What of the Future?" Ernest Urchs, treasurer of Phillips & Crew Piano Co., of Atlanta, Ga., and Clark & Jones Piano Co., of Birmingham, Ala., respectively Victor jobbers and dealers, said to the Talking Machine World:

"To prognosticate the future is of course impossible, but the industry in musical instruments is now affected from so many angles that it behooves us to give the question of the future most serious thought, and I believe that the majority of merchants who have the habit of looking ahead are doing just that. Some view the future with alarm, but I am not one of them. True, production cannot be brought back to normal until we have won the war and won it on the premises so ably laid down by President Wilson and so magnificently supported by the people.

"But with production back to normal, the principles of merchandising, I believe, will undergo some radical changes. While cost of labor and material will not be as high after the war as they are now, the pre-war basis, in my opinion, is a thing of the past. Supply and demand are, of course, always the determining factors. But compare the cost of living of our boyhood days with those, say, of 1904. Consider the increased cost of living in 1914 over 1904, and in turn to the present day, and we must arrive at the conclusion that the cost and the standard of living will be higher after the war than it was in 1914.

"We must also take into account the legislations which have been enacted, the court decisions rendered and the psychological attitude of our lawmakers and the people toward business in general. Our statesmen seem to fear that the enactment of a law, for instance, like the Stephens bill, might work injustice to the consumer. That's the present mental attitude in Washington, as I see it. The Victor Co. and the National Talking Machine Jobbers' Association have done splendid work in throwing light on the justness and advantages of that bill, and I believe their activity has not been in vain. However, its adoption is far from accomplished, if, indeed, it will ever be.

"Per contra, Washington in its wisdom is controlling prices and distribution on many articles used for war purposes. The action of Congress in thus fixing prices on what is regarded as 'essential' is in marked contrast with their refusal thus far in permitting price fixing on the so-called 'non-essentials.'

"Will the wise and far-seeing course of Congress in fixing prices on 'non-essentials' show its members 'the light' toward the end that the Stephens bill will be passed, or will Congress, with the close of the war, abrogate price fixing even on commodities now regarded as 'essential'?"

"Have we who see the justice of the one-price

system, we who know the value of a contract and who feel a contempt for anybody who does not live up to it or who acts in collusion to break it, enough force of character to bring our convictions home?"

"We must show that the unprincipled merchant who advertises cut prices is a menace to any industry because he does more harm to the army of men and women employed in that industry than the benefit which a few hundred people derive from buying at a cut price. We



Ernest Urchs

must put a quietus on secret rebates, a practice no less harmful than that of the avowed price cutter.

"And now let me say right here parenthetically, and as bearing on this discussion, that the resignation of Mr. Geissler as general manager of the Victor Talking Machine Co. has occasioned widespread regret tempered only by a sense of relief that he is to be retained on the board of directors. The talking machine trade needs men of Mr. Geissler's perspicacity, earnestness and force, and I venture to say that no man and no corporation in the music industry have given more weighty and potent consideration to the interest of the jobber, the dealer

and the consumer than Mr. Geissler and the company of which he is the managing director. Naturally, when there is so much at stake for manufacturer, jobber and dealer from the investment standpoint, both in money and brains, speculation is keen as to who will be Mr. Geissler's successor. To make no mistake in the major policies is the prerequisite. Human fallibility is a guarantee of errors, but so long as they are minor the future general manager of the Victor Talking Machine Co. will steer the ship on the same safe course as did Mr. Geissler.

"In the meantime the beneficent policies of the Victor Co. in the past give assurance of loyalty on the part of the Victor jobber and dealer. What was once a 'rule,' a 'contract' in the trade is now a principle and a privilege without a thought of compulsion because experience has taught us that Victor merchandising is safe and sane and the embodiment of the square deal.

"I have been all over this country during the past three months and the expressions of opinion were unequivocally to the effect that the Victor policies are a benefit not only to the Victor department, but every other branch of our business. We are free to do as we please—then why give up a good thing?"

"But to continue. Assuming, then, for the sake of argument, that legislation on the one-price system will be adverse to the goal which we have set for ourselves, why, then we will adjust ourselves to existing conditions and find a way that will give us the necessary protection with the approval of our lawmakers. New distributing methods will have to be created that will not affect the standing or the interest of the jobber as an entity. Means will have to be devised that will establish a wholesome co-ordination of the activities of manufacturer, jobber and dealer—and, what is no less to the point, the safeguarding of the purchasing public in the economic as well as the artistic sense.

"All this, I believe, can be done, and at the same time strictly adhering to the letter of the law. I have some well-defined ideas along these lines, but, of course, I cannot go into that now. Besides, general policy outlined, the lawyer must decide whether the layman's ideas are correct. They may be revolutionary as compared to present methods, but they must be logical and legal.

"Those are the thoughts that are agitating the minds of the meditative merchant, and ample food for thought is contained therein."



This Trade-Mark on a Record Album Stands for Quality

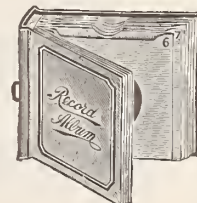

A complete line of albums—from the lowest-priced good album to the finest metal back album made.

Write for sample of our 3 grades

New York Album & Card Co., 23-25 Lispenard St., New York

and

Pointers
Repointers
On the Many
Advantageous
Features
of the
“B and H” Fibre Needle



U. S. Pat. Nov. 12, 1907

Pointers

The “B and H” Fibre Needle in its now perfected state is the result of years of research and labor for the best material and results obtainable.

The fibre of the finest bamboo wood in the world is of a texture which never can injure the indentations recorded on a record.

The oil in which each needle is steeped gives out just that degree of lubrication which will be found a help in cleaning and keeping records free from dust.

Wood is well known to be the substance most responsive to the vibrations of sound and the texture of these needles is of such a perfect grain as to develop the vibrations gathered as they enter the indentations on the record in the most perfect manner, and with the most pleasing effect.

The Only Fibre Needle
Licensed for Sale
in the U. S.



The Repointer



U. S. PATENT DECEMBER 5, 1916

Suggested Retail Price, \$2.00

Pointers

It is the high quality of the material used in the “B and H” Fibre Needle, and the scientific treatment and preparation to which it is subjected, that gives it the beautiful tonal effect so much admired.

Its rare quality of tone is most admired by those who appreciate the artistically rendered selection, rather than the harsh production which may please the few without music in their souls, and it is among the former class that the most liberal purchasers of records will be found.

Dealers can not recommend the “B and H” Fibre Needle too highly to their patrons, for a trial will substantiate our every claim, and the pleasure of having found a satisfactory needle, free from rasping noise, will be an incentive to the purchase of new records, and usually the choice and most profitable ones to sell.



**The “B and H” Repointer Is A Valuable
Adjunct to the “B and H” Fibre Needle**

By its use a needle may be repointed eight or nine times. This extended use of the same needle is not only a matter of needle economy, but it will be found that repointing appreciably improves the quality of tone.

The sale of the repointer helps the user of needles and the use of the needles helps the sale of records.

The Dealer Should be Equipped to Benefit



“B and H” Fibre Manufacturing Co.

33-35 W. Kinzie Street, Chicago, Ill.

How Business Success Is Augmented By the Handling of Collections in a Tactful Way

Success in business depends very much upon the personal relations of dealer and customer, so that a dealer in a small community is likely to suffer if he gets the reputation of being too sharp after the money. On the other hand, he certainly loses out if he is too easy, says a writer in "The Voice of the Victor." Much depends, therefore, upon the tactful handling of cases in which collection is slow.

As a general rule it will be found that slow-pay customers can be divided into three classes:

Those who have money but are slack about paying, either through carelessness or through habitually living up to the limit of their incomes.

Those who are chronic kickers and like to make trouble whatever they do.

Those who are in financial trouble of some kind and unable to pay.

The first class is by no means uncommon in spendthrift America, and people of this kind are rather dangerous to handle. Money comes easy, and therefore they do not realize its value, and have no conception of the difficulties that crop up when there is an actual shortage. They are very irritating, and one may feel like "giving them a lesson"; but is it worth it? They are usually honest enough, and will pay sooner or later, and once they have paid up they will immediately get into debt again. Moreover, if you irritate them too much they may feel like giving you a lesson—in courtesy, and deliberately put you to all the trouble they know how. And in any case, they will say to their friends, "Why on earth do you go to Blank's for your records. He's an awful Shylock, and he never has the records you want." How about it?

No; these people are inclined to be selfish, but they are human. If approached in the right way they can be persuaded to pay their bills. And what is the right way?

Well, suppose you were a careless person, of a selfish disposition, and you received a statement with the curt command on the bottom, "Please remit"—would you feel like doing it? Or, again, suppose you got a chilly letter, obviously part of a regular, standardized system: "Dear Sir: The inclosed account is very much overdue. Unless a check is received by Friday, the thirteenth of the month, we shall obtain legal redress." Would you like that? No, indeed. It would most certainly "get your goat." Very well, then, how about this?
"Dear Mr. Jones:

"In order that you may enjoy the advantage of a complete stock of Victor records from which to make your choice, we are obliged to maintain a very large quantity on hand. This means tying up a considerable amount of money. If we are to maintain the good service which we aim to have at your disposal, we cannot afford to give extended credit.

"The inclosed account has doubtless escaped your notice, but by giving it prompt attention you will enable us to simplify your shopping very considerably."

Surely it would do no harm to point out to a selfish person that by paying his account on time he is adding to his own convenience. And if selfishness is the weak spot in his armor, aim at it with your first shot; that is why we began the letter with a suggestion regarding the customer's personal enjoyment of Victor records. The chances are that along with thought of these two things will come the remembrance of his account, so that the rest of your letter will serve to strengthen the impulse to pay. If there was no impulse, a letter of this kind is far more likely to create one than a threat; and it does not irritate a customer who may have influence with other and better customers.

Customers of the second or "chronic kicker" class are much easier to handle. By chronic kickers we don't mean those sometimes very

estimable people who insist on getting value for their money, paying every bill as if it were their last—but paying. The proper way to treat a person of this kind, of course, is to make a fuss over him, listen patiently to his complaints, get him flattered with the thought that he is a mighty good judge who is hard to please—and so make him run up another bill. No; the chronic kicker is a bird of another kidney. He works up a dispute for the very purpose of get-

Approach People the Right Way and They Can be Persuaded to Pay their Bills Without Much Difficulty

ting extended credit, and goes out of his way to be disagreeable. Dealers are sometimes disposed to be overpatient, but it really doesn't pay. The chances are, moreover, that he has made himself equally objectionable to other tradespeople, and the whole community will rejoice to see him get a jolt. A prompt threat of legal proceedings will often bring him to order; if it doesn't, go straight to the legal proceedings. It won't do any harm—especially if you have built up a reputation for generosity in more deserving cases.

The third class of non-pay customers—those who are temporarily or permanently under a financial cloud—needs the utmost consideration. If after careful investigation you find that a customer actually cannot pay, the most profitable thing left to do is to be magnanimous about it. The world loves a good loser, and will often go out of its way to see that he gains by it in the end. Moreover, most people are more honest even than they know themselves to be.

The manager of a large mail-order house dealing with people all over the world in small accounts told the writer that not more than 6 or 7 per cent. has to be written off for bad debts each year, and most of this percentage is practically unavoidable—the result of sickness or other misfortune. This house is particularly generous in the matter of credit. When the Dayton floods occurred a few years ago, customers in that neighborhood were notified that accounts might stand over until a later date, or in certain cases were actually excused from payment. Did the firm suffer for its generosity? Not so as you could notice it in the dividends, which were higher than ever that year. It pays, if on investigation you find a customer has been hard hit, to go to him and say, "Look here, old man, I know you'd pay your account if you could; but I don't want to add to your troubles, so take your time." If he is any sort of man, he will see that you get paid in the long run; and he won't fail to tell his friends that "Blank is a mighty nice man to deal with."

To sum up: "Be tactful with those who can pay but don't; be strict with those who can pay but won't; and be merciful with those who would pay but cannot."

Delpheon
the
Incomparable

A tone that is ineffably exquisite—not phonographic

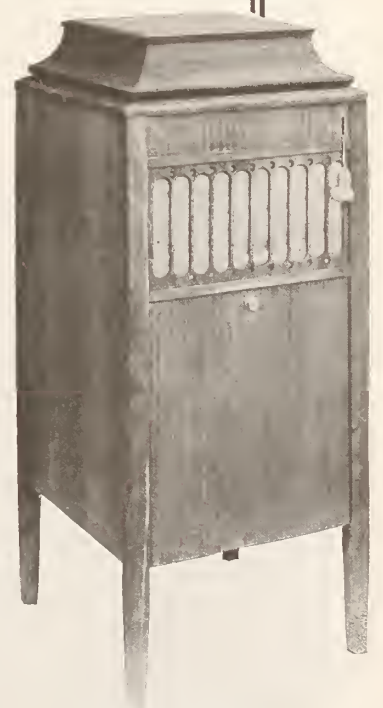

Delpheon \$75 Model

THE DELPHEON COMPANY
BAY CITY :: :: MICHIGAN
OR WRITE TO DISTRIBUTORS

VICTOR CO. ANNOUNCEMENT EXPLAINS WAR CONDITIONS

Comprehensive Statement From General Manager Geissler Tells What the Victor Talking Machine Co. Is Doing to Help the Government—Reasons for Reduction in Output

The Victor Talking Machine Co. under date of September 13 has issued over the signature of Louis F. Geissler, general manager of the company, the following comprehensive statement regarding the present status of the company's affairs in the matter of production, and what is being done at the Victor plant in the line of Government work. The statement direct from the company will no doubt be greatly appreciated by all those who are interested in the handling of Victor goods. It reads:

"Since war was declared in April, 1917, the management of this company has, without hesitancy because of the unavoidable loss to itself, devoted its full energies towards the fulfilment of two purposes, i. e., to assist the Government in every practicable way and to provide for the needs of the trade as fully as the circumstances would permit. We have several times had it in mind to address the trade on this subject, but conditions have changed so rapidly and there were so many elements of uncertainty involved that it has not heretofore seemed wise to hazard an opinion. Even now it is only possible to review developments to date, to state present conditions and indicate the probabilities for the future as we see them.

"Upon the entry of our country into the great war investigation was made to ascertain whether the facilities of the Victor plant would be required for the production of war materials. It appeared that our facilities would not be so needed and we accordingly prepared to continue and increase our own manufacturing program, with the result that during the first six months of 1917 our shipments totaled a substantial increase over 1916.

"Towards the end of 1917 we were requested to assist two branches of the country's fighting forces, in an emergency, by manufacturing small quantities of very intricate and important devices, which we are unable to specify because of the fact that the Government has not published anything concerning its efforts and results obtained along this line. The quality of the work produced by the Victor plant in these few cases evidently attracted attention, and at the beginning of 1918 we were asked to undertake larger manufacturing orders for articles of most vital importance in the prosecution of the war. We were glad to do this, not only because of the opportunity to serve the

Government in a very direct and real manner, but also because many of our skilled workmen felt it to be their patriotic duty to become engaged in war work. It was obvious that the interests of the Government, of the trade and of this company would be best served by our giving these men an opportunity to do here, rather than somewhere else, the kind of work they preferred.

"A great deal of attention has been paid to the utilization of female labor to replace that of the more than one thousand of our men who have actually entered the army and navy and the still greater number who inevitably were attracted to new industries resulting from our country's participation in the war.

"We have known of the insidious rumors circulated by competitors to the effect that the Victor Co.'s supply of materials was the cause of our reduced output, but have made no answer for the reason that we felt the trade would do us full justice in forming their opinion as to whether or not the Victor management had been far-sighted in the matter of providing for its ordinary requirements. However, we have at all times paid strict heed to the rules and the needs of the Government and have not taken advantage of any opportunity to surreptitiously acquire materials which the Government had announced should be devoted to other purposes. Short periods of embarrassment because of the fuel situation, railroad embargoes, etc., have been overcome; our situation with regard to materials is at present good and we have no doubt that we shall be able to continue the manufacture of instruments and records in fully as large a proportion to our last year's business as any other manufacturer can hope to do. In this connection it will be interesting to you to know that responsible administrative officers of the Government have expressed themselves as regarding our products as 'prime necessities of peace times and very important to the welfare of the country in war times.' We are confident that the talking machine industry will not be unnecessarily discriminated against by the Government, but that its activities will be encouraged to the limit that can be done without interference with the production of ships, aeroplanes, rifles, ammunitions and the other prime necessities of warfare.

"We shall continue to cheerfully assume the

sacrifices we are required by duty to make and we have no doubt as to the willingness of our trade to respond in fully as whole-hearted a manner. We feel that our trade is entitled to know that, in spite of all that we could, consistent with our duty, do to maintain the volume of production, our output of instruments has been reduced to less than 50 per cent. of our maximum capacity. We are very hopeful that a period of a few months will suffice to provide for the needs of the War and Navy Departments in labor and material, and that after regular production of war materials in sufficient volume has been accomplished an improvement in conditions affecting industries such as ours will be witnessed. Certainly, the next few months will be the most trying period of the war.

"Our output of records has been reduced a little more than 30 per cent., but, as the manufacture of records can be carried on by women and men who are not available for war work, we believe that we may look for some increase in the output of records.

"This plain statement of our position may or may not be wise, when viewed from the standpoint of our own interests, but we believe that the issuance of such a statement to our trade is the right thing to do and we, therefore, commend it to your thoughtful consideration.

"Looking forward to victory and the cessation of hostilities, we desire to assure you that we will reach this point with fully matured plans to lead the way in the development of our industry and to greater prosperity than the trade has ever known before."

DENOUNCE BUSINESS ALARM

Credit Men See No Reason to Fear Post-War Panic in the Business World

Under the caption "An Alarmist's Note—Does It Find an Echo?" the September letter of the National Association of Credit Men calls to task a member who recently gave it as his belief that the end of the war would witness a large number of business failures.

"We are satisfied," the letter says, "that the member who has recently been sending broadcast the alarming notice as to the large number of failures that is to be expected at the conclusion of the war might have exercised better judgment in his choice of methods.

"We urge as strongly as does our alarmist member that all be guided by principles of extreme conservatism and prudence, analyzing every proposal with extreme care. With this spirit established we believe the period of deflation can be approached with equanimity, presuming, of course, that that splendid co-operation that this war has given rise to shall continue.

"There are many tremendously important elements pervading our national and economic life which we were not in possession of at the conclusion of the Civil War. First, there has been developed a more popular understanding of economic principles, a business science has been uncovered which has made for permanence and stability; and second, we have been developing astonishingly the power of co-operation, not by sections as sixty years ago, but nationally—we may almost say internationally.

"Again, we have the Federal Reserve system, the like of which has never before been possessed by any country—a system which is proving itself not only a mighty financial factor, but has become a leader in sound business life."

REAL CAR INSURANCE

An automobile owner who fixed up his car so that the horn with a talking machine attachment uttered some very emphatic and not over-refined language when a thief tried to start off with the car is so well pleased with the invention, according to the society reporter of The Hutchinson Gazette, that he is now working to perfect a device which will hit the thief over the head with a monkey wrench. This is truly a progressive age.

Ward's Khaki Moving Covers



Grade "D" Cover with No. 3 Straps.

PROTECT YOUR MACHINES FROM ALL KINDS OF WEATHER

and will enable you to deliver them free from dust, scratches, bruises and all other finish destroyers

Our covers are faced with Standard Khaki, lined with a heavy grade flannel, interlined with an exceptionally good grade of heavy cotton or felt, diagonally and closely quilted, and manufactured according to the usual superior "WARD New London" quality.

Grade "D", medium size, \$6.00
Grade "D", large size, \$6.50
Grade "K", medium size, \$8.00
Grade "K", large size, \$9.00

Carrying Straps: No. 1 \$1.00; No. 2 \$2.00; No. 3 \$3.50

ORDER SAMPLE COVER ON APPROVAL

With Name of Machine silk embroidered on any Cover; extra, 30c.
With Dealer's Name and Address, first Cover; extra, \$1.15
Same on additional Covers, each extra, 60c.

Write for booklet

THE C. E. WARD CO.

(Well-known Lodge Regalia House)

101 William St., New London, Ohio

Also Manufacturers of Rubberized Covers and Dust Covers for the Wareroom

THE RECOGNITION AND REPRESENTATION
of the
AEOLIAN-VOCALION
and
NEW VOCALION RECORD

WHEN The Aeolian Company brought out the Aeolian-Vocalion three years ago, it marked the entrance for the first time, of a real music house into the field of phonograph manufacture.

Up to that time the development of the phonograph had been in other hands. Originally designed as a "Talking Machine," scientific inventors and clever mechanics had brought it to a high state of *mechanical* perfection.

Wonderful as it was, however, as a machine, it left much to be desired as a *musical instrument*. And its perfection as such could only be accomplished by men who were not only skillful mechanics, but *trained musicians* as well.

The staff of The Aeolian Company included such men—men whose achievements in musical instrument building had made The Aeolian Company famous throughout the world for the character and quality of its product.

From the first the Aeolian-Vocalion demonstrated that The Aeolian Company had built a new and superior type of phonograph, musically as well as mechanically, far in advance of those on the market.

Recognition from various sources came quickly. Musicians, tone experts and the public did not hesitate to accord the Vocalion

the recognition it so obviously merited.

Recognition by the music dealers of the country has also followed. The list of those handling the Vocalion today is large and rapidly increasing, and contains the names of many of the best-known and most progressive merchants in the trade.

The introduction of the new Vocalion Record—as superior and revolutionary in its way as was the Vocalion itself—together with the extension of service to include an increased number of convenient distributing centers throughout the country, has greatly increased the advantage of Vocalion representation.

The following page contains a full newspaper page announcement of one of the new dealers to take the representation of the Vocalion. The name of this house is too well-known to require explanation, and the significance of the event cannot be overlooked.

The third and fourth pages following, reproduce two of the advertisements that are part of the strong Vocalion publicity campaign running in different parts of the country.

Representative music dealers are invited to investigate the subject of Vocalion representation while territory for this valuable and increasingly important instrument and record is still available.

AEOLIAN HALL
New York
World Headquarters
of the Aeolian Company

The Aeolian Company
Announces that

Denton, Cottier & Daniels

Have taken the Representation of the
AEOLIAN-VOCALION
And the New Vocalion Record.

THE AEOLIAN COMPANY takes not only pleasure but pride in making this announcement. Any industry flourishes or languishes, depending on the power and integrity of the firms and individuals who foster it. The music industry is no exception to this law.

Denton, Cottier & Daniels have been established since 1827. Since then, the entire effort of this house has been public and institutional—immediate profit always being subservient to public confidence and permanent success.

But—Denton, Cottier & Daniels is far more than a mere music store. This famous old house is not only recognized as one of the strongest constructive forces in the music trade; but enjoys the confidence and respect of its public today, in a measure rarely equalled in the music or any other industry.

Therefore, The Aeolian Company is proud to have the Aeolian-Vocalion represented by such a house.

The AEOLIAN-VOCALION has made a success—a phenomenal success. The public—that great jury of award—has passed upon the Aeolian-Vocalion and accorded it the premiership of the phonograph world.

The same jury is now passing upon the new VOCALION RECORD—that wonderful companion of the Vocalion. Even now the verdict is rendered—for the Vocalion Record is already taking the position to which rightfully entitled, as the most musical, most perfect, and most satisfactory phonograph record ever produced.

Its success, and that of the Vocalion, is due to the will to excel, the spirit of initiative, the vast and unparalleled experience and equipment that have enabled The Aeolian Company to produce musical instruments that dominate, through sheer superiority, the markets of the world.

Denton, Cottier & Daniels
32-38 Court Street

The New Abode of the

AEOLIAN-VOCALION And the New Vocalion Record

HERE, in this splendid establishment, where the world's finest products in musical instruments such as the Steinway Piano and the wonderful Duo-Art Pianola Piano are displayed, the Aeolian-Vocalion has taken its permanent abode.

The Aeolian Company backs and pushes its products with all the power and resource of its immense organization; so that, today, in spite of its relative newness, the demand for

the Vocalion far surpasses the manufacturing capacity of its makers.

But, The Aeolian Company, as manufacturers of the Aeolian-Vocalion, make this pledge: Despite present conditions, despite the difficulties with which all manufacturers are faced, the warerooms of Denton, Cottier & Daniels will never be without an adequate representation of the best types of Vocalions within the power of The Aeolian Company to produce.

YOU ARE INVITED

The exhibition of Aeolian-Vocalions is now open. The public is cordially invited to visit the warerooms of Denton, Cottier & Daniels, to listen to a demonstration of this wonderful phonograph and record.

THE AEOLIAN COMPANY

NEW YORK LONDON PARIS SYDNEY MELBOURNE





Hear the New VOCALION RECORD of the famous "MARCHE LORRAINE"

The Favorite March of the Allies

IS there anything in the world so thrilling as a big military band sounding its martial call to patriotism and valor? Everywhere, nowadays, splendid brass bands are swinging through the streets playing, and behind them, keen-eyed, straight of shoulder, soldiers are marching, marching.

Unconsciously, as we look and listen, we square *our* shoulders; and while our feet keep time to the soul-stirring rhythm, our hearts beat fast with high and deathless resolve!

We lesser ones here at home cannot have always a great military band to fire us with the spirit of strength and sacrifice, but we may have the miracle—so used to it are we now, that the miracle of it almost escapes us—of the phonograph.

You do not know phonograph music in its perfection unless you have heard the Aeolian-Vocalion playing the new Vocalion Record.

You do not know how completely the thrill of a full brass band can be transmitted to you by means of disc and needle until you hear one of the Vocalion Band Records.

The "Marche Lorraine", played by the Vocalion Military Band, has been given daily



during the recent demonstrations of this new Record at Aeolian Hall, and hundreds of people have been amazed at the glorious realism of this great, new system of music-reproduction. So complete is the illusion that with one's eyes closed it seems as if the actual band were playing but a few feet away.

The bold, clear fanfare of horns at the beginning; the melodious beauty of the second part; the boom of drums—the crash of cymbals and brasses—every instrument, from delicate piccolo to double bass is as clearly outlined for your musical ear as it is on the retina of your eye when they pass before you.

* * * * *

The Aeolian-Vocalion plays all records and brings out beauties and depths of sonority unrevealed by other phonographs. Every artist or body of artists who has made records for any phonograph may be heard to unequalled advantage on the Vocalion. But the final perfection of phonograph music is to be found *only* in the Aeolian-Vocalion, playing the New Vocalion Record.

Come to Aeolian Hall and hear the new Vocalion Record. Your own ear for music is the best demonstration we could wish you to have. You will be able to detect at once the superiority of this latest Aeolian achievement.

THE AEOLIAN COMPANY

In MANHATTAN
29 West 42d St.

In THE BRONX
367 East 149th St.

In BROOKLYN
11 Flatbush Ave.

In NEWARK
895 Broad St.

Lend as
they fight

Buy more
Bonds now



The
VOCALION RECORD'S
*Tone Portrait of a Rich
Baritone Voice*

THE subject is Giacomo Rimini's masterly interpretation of the ever-beautiful "Eri Tu?" (Is It Thou?) from "The Masked Ball." This number, one of Verdi's great inspirations, requires vocal and dramatic ability of the first rank—and Rimini's fine voice and appealing temperament render him peculiarly well-fitted to sing the music of his famous compatriot.

As a tone-picture, the Vocalion Record of this great aria is faultless.

Every note and phrase is natural and true to life. Every shade of tone-color and expression is caught and retained by this advanced process of recording. It is recognized among musicians that such portrayals of human and instrumental tones have never before been heard.

GIACOMO RIMINI

This young Italian Baritone has already won an enviable reputation in operatic circles, both in Europe and the Americas.

For the past two years Rimini has been one of the leading baritones of the Chicago Opera Association, having been conspicuously successful in La Tosca, Aida, The Barber of Seville, Isabeau, and the Jewels of the Madouna.

Rimini's voice is of rich, sonorous quality and is reproduced with the utmost naturalness on his Vocalion Records.

Pay a visit to the Record Department, Aeolian Hall, and ask to hear "Eri Tu?" from "The Masked Ball."

THE AEOLIAN-VOCALION

Besides the opportunity to play the glorious new Vocalion Record, this versatile phonograph offers many other unusual advantages.

It plays all standard disc records—plays them with fuller, clearer tone.

The Graduola tone-control feature offers you the privilege of indulging your own fancies as to tone-color, accent and expression.



Style G
Price \$115.

The Vocalion case designs are distinctive. In appearance it has no equal.

Its mechanical features, such as the Automatic Stop, Volunome, etc., are the most effective on the market today.

The Aeolian-Vocalion is priced from \$50 upward. Models containing the Graduola from \$115. Sixteen beautiful period styles from \$240.

THE AEOLIAN COMPANY

In MANHATTAN
29 West 42nd St.

In THE BRONX
367 East 149th St.

In BROOKLYN
11 Flatbush Ave.

In NEWARK
895 Broad St.

EDISON CONVENTION AT NEW ORLEANS A GREAT SUCCESS

A. P. Burns, Assistant General Sales Manager of Thos. A. Edison, Inc., Tells of the Very Important Gathering of Edison Dealers Recently Held in the Crescent City

A. P. Burns, assistant general sales manager of Thomas A. Edison, Inc., recently represented the company at the Edison convention at New Orleans, which was referred to briefly in our last issue.

In an interview with our representative immediately after his return Mr. Burns had the following to say:

"There is something about the city of New Orleans and the people that live in and about it that radiates a spirit of cordial hospitality, noticeable to a visitor immediately upon his entrance to that charming Southern city. This

interest, and from then on to 12 o'clock there was an open discussion from which the dealers present secured very interesting information. At 12 o'clock the convention adjourned, and we had luncheon at the famous Galatoire French Restaurant in the French quarter of the city, and I don't mind saying it was some luncheon. Our photograph was then taken. During the afternoon several informal speeches were made and the business was completed by 4 o'clock.

"About 4.30 we all went sight-seeing in a Packard Rubber-Neck bus. We all had a very good time, even though the bus did break down

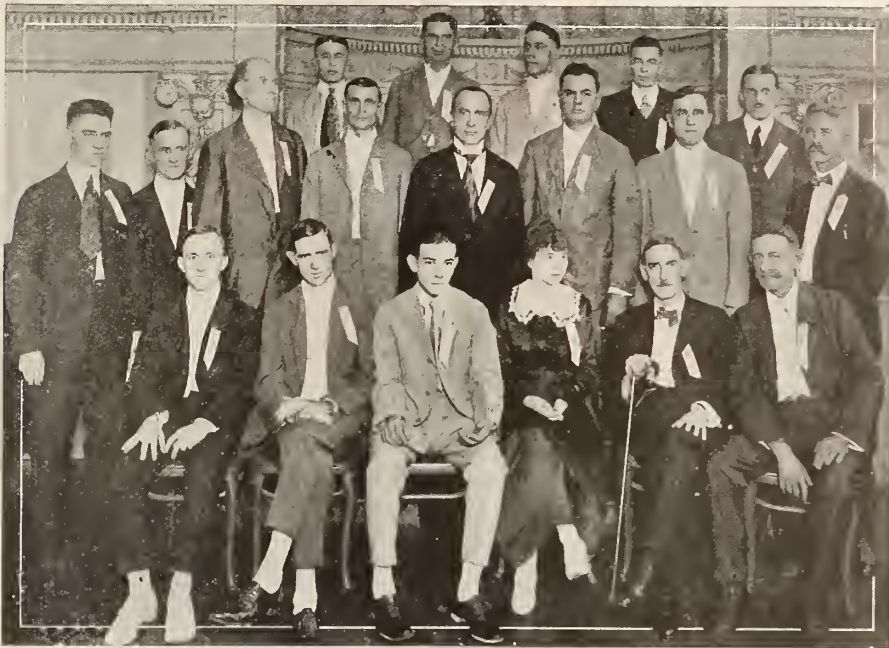

Delegates to Edison Convention in New Orleans

spirit of hospitality, combined with the spirit of co-operation, was very evident at the New Orleans convention of Edison dealers.

"The convention itself was altogether informal, like a meeting of brothers—there were no set speakers—whoever wished to emphasize or inform his brother dealers of new methods of securing business, of building up prestige, of making money with the Edison product, did so impromptu.

"The convention was opened by Mr. Donnelly, manager of the Diamond Music Co., with a message of welcome to the dealers in his zone. Then I spoke on a few subjects of pertinent in-

and could not be started. A hurry-up call was sent to a mechanic, and although he received advice from everybody present he was unable to start the machine. A second hurry-up call was sent for a couple of autos and our trip continued. We saw many interesting sights similar to those you have all seen if you have ever visited New Orleans. Then came the banquet at La Louisianne, one of the most famous restaurants on the continent. In short, the New Orleans convention was a success from start to finish."

Don't tell all you know or guess.

DISPLAY RED CROSS PHONOGRAPH

The Crafts-Starr Phonograph Co., of Richmond, Va., Show Very Beautiful Instrument

RICHMOND, VA., October 3.—The Crafts-Starr Phonograph Co., of this city, report an enormous demand for the Starr phonographs and Gennett records which they handle in a wholesale way. In fact, the demand is so great that their two traveling salesmen have discontinued soliciting trade and are only covering their territory now to see that proper service is given and to keep up acquaintances. This company supplies some of the oldest and largest music houses in Virginia, North Carolina and part of Maryland and West Virginia, who are most appreciative of the service which is given them by the establishment.

A recent feature of the window display of the Crafts-Starr Phonograph Co. at 230 North Second street was a Red Cross Starr phonograph which was made to the order of a wealthy citizen in Richmond. It is a perfect Starr instrument with a large motor and heavily gold-plated. The entire case of the phonograph is enameled white with a large red cross on the front. A gold plate bearing the name of the donor will be placed on the instrument just before it is given to the Red Cross Society. It is a most unique and attractive gift and has cost the patriotic donor a neat sum, but he wants it to be a perfect thing of its kind, and Mr. Crafts ordered every detail carried out in the best materials that could be had, and no trouble or expense has been spared. It is on display for a time and it certainly makes one of the most attractive windows in the city.

MAY NOT IMPORT MAHOGANY LOGS

War Trade Board Prohibits Further Importation for Non-War Use

By a new ruling of the War Trade Board (W. T. B. R. 222), all outstanding licenses for the importation of mahogany logs and mahogany lumber have been revoked as to ocean shipment after September 10, 1918. Hereafter no licenses for the importation of these commodities will be issued, except to cover such shipments as the Director of Lumber of the War Industries Board shall certify to be suitable and necessary for Government use.

The Hyatt Talking Machine Co., of Portland, Ore., has moved to 350 Alder street, where it will have greatly enlarged floor space, which is necessary to accommodate its constantly increasing business.

NYOIL

is the last word in the refining of high-grade oils, for every impurity is taken from it, leaving nothing but what is required to keep machines in perfect condition, being combined of four oils perfectly blended.

Will not Gum, Chill or become rancid; is free from acid. It is colorless and has no sickening smell, being absolutely odorless.

"The finest and most delicate pieces of mechanism do not prove efficient unless properly lubricated. Skill, Genius, Invention and Workmanship must have the proper Oil. Stop and consider this when you have to buy an Oil for household use."

Hundreds of satisfied customers have written us that they would never use anything else for

TALKING MACHINES, GRAPHOPHONES, PHONOGRAPHS AND SEWING MACHINES

• NYOIL will lubricate the machinery and polish all woodwork

and can be obtained of any "Up-to-date" Talking Machine Dealer in the world, and is manufactured by Wm. F. Nye, who for 50 years has made 80% of all the Watch, Clock and Chronometer Oil that is used in America.

WM. F. NYE, NEW BEDFORD, MASS., U. S. A.

NYOIL is put up in the following sizes:

No. 16 (Cans)	1 Pint
No. 32	1 Quart
No. 128	1 Gallon
No. 540	5 Gallon

NYOIL is put up in the following sizes:

No. 1 Bottle	1 ounce
No. 4	3 ounces
No. 8	8 ounces

Columbia Grafonola



THE greatest operatic music was beautiful before it was great—and Columbia Records bring you the best of that magical beauty.

Haunting melodies, exquisite catches and snatches of song, music of joy and of laughter, glorious marches, the fanfare of trumpets, majestic choruses—all that and more have Columbia Records.

SUCH great artists as Lazaro, Stracciari, Barrientos and Mardones make records exclusively for Columbia. But the music they choose for recording is always the truly great music of beautiful and inspiring melody. Beautiful melody—that is the distinguishing quality of both Columbia Records and the Columbia Grafonola. Music you really like, played as you like to hear it—that's what they give you always.



To make a good record great, play it on the Columbia Grafonola.

COLUMBIA Records on the Columbia Grafonola bring the best music of all lands and all ages into the friendly intimacy of your own home. They make good music what it ought to be in every family—an enduring source of pleasure and inspiration, a solace in time of trouble, an added joy in happy days.

A very human sort of an instrument is this Columbia Grafonola. A big, handsome, musical friend with a voice that is sweet and clear and strong, bringing good cheer to every home he enters. You need his cheerful voice in yours.

Buy War Savings Stamps

Columbia Graphophone Co., New York



Columbia Grafonolas—Standard Models up to \$300. Period Models up to \$2100. Prices in Canada plus duty.

Columbia Grafonola

Bring the Opera Season to Your Town

WITH the opening of the great opera seasons in New York, Boston and Chicago; with concerts, recitals, symphonies and philharmonic societies getting started everywhere for the winter, the thoughts of music lovers turn to the more classic in music.

That is why the Columbia full page advertisement shown on the opposite page is devoted to operatic artists who make Columbia Records. Lazaro, Barrientos, Stracciari, Mardones and other world-famous stars soon will be singing their great roles. This advertisement will bring the fact that they make Columbia Records to the attention of millions of people—thousands of whom are or should be your customers.

Bring the opera season to your people. This advertisement appears in many of the leading national magazines. Millions of people will see it. Make it work for *you!* Tie up your local publicity with these great Columbia artists—have a good assortment of the great operatic arias—and bring the opera season to your town.

Columbia Graphophone Co., New York



THE TRADE IN BOSTON AND NEW ENGLAND

JOHN H. WILSON, MANAGER, 324 WASHINGTON STREET, BOSTON, MASS.

Boston, Mass., October 1.—All the talking machine shops have more or less suffered from the prevailing epidemic the past few weeks, but at this writing it is believed that the worst is over. Not an establishment in the city but was badly hit for a time and some places were crippled for several days at a stretch because of absent employes, sufferers from the grip. During the past few days the weather has been very good and this has helped materially to stay the disease.

Liberty Loan Campaign in Full Swing

The Fourth Liberty Loan campaign is on in full force and the trade has been making plans for some time to make as good a showing in volume of subscriptions as it has on the previous loans. On one of the committees which will canvass the trade is Thomas W. Hindley, manager of the Aeolian-Vocalion's Boston headquarters. Business with the various houses has been very good of late, and September as a whole appears to have made a good showing, while the trade is optimistic over the prospects for the remainder of the year. The curtailment of product is felt everywhere and dealers are reconciling themselves to receiving only a percentage of their orders.

More Men to the Front

Robert Steinert, who is capably managing the Victor business of the M. Steinert & Sons Co., with headquarters at the Arch street store, has just lost two more men in the draft, James Graham and Herman Fleischman, both outside men. Graham has entered the navy and Fleischman has been taking a course in aeroplane engineering at the Wentworth Institute. Because of the shortage of men the house is thinking seriously of giving young women an opportunity of seeing what they can do in this particular line of work, that is, in the wholesale end of the Victrola business. A new man in the stock room is Douglas Collier, who has had a sound experience in the talking machine business before he joined the Steinert house.

Why Mr. Fitzgerald is Proud

Wholesale Manager Billy Fitzgerald, of the Eastern Talking Machine Co., is justifiably proud of one of his young nephews who is in service in France. The name of the young man is John J. McCarthy. He is a resident of Somerville, a graduate of Tufts College, and twenty-three years of age. He went overseas with the 101st Engineers and one year to the day he was

appointed an instructor in the chemical warfare service with the rank of first lieutenant. McCarthy has a medal for bravery, which he carries in his pocket, and his superior officers say he knows no such thing as fear.

Eastern Co. Men All Doing "Their Bit"

Speaking of foreign service, Billy Fitzgerald tells The World correspondent that he expects to be overseas himself within a few weeks. Just now he is busy filling out his questionnaire and is claiming no exemption. George McDonald, of the Eastern's staff, is in the aviation service, and John Dockery, another of the staff, has just been put in class 1-A. In all, the Eastern has lost about twenty-eight men and a service flag may soon tell passers-by what this popular house has done for the country by way of furnishing men for service. The Eastern's business continues good, but the scarcity of materials continues to be felt.

"Thrift Model" Aeolian-Vocalion

With the admonition to buy Fighting Fourth Liberty Bonds the Vocalion Co. announces from its Boylston street warerooms a special offer in "the beautiful new thrift model Aeolian-Vocalion with twelve record selections." This advertisement, attractively prepared by Manager Thomas W. Hindley, appeared almost simultaneously with the Liberty Bond propaganda and created a big hit with the public who were quick to "catch on" to the significance of the ad. Manager Hindley states that business has been coming along very well, for which credit is due in no small degree to the capable staff with which he has surrounded himself, each member of which is familiar with the talking machine business.

W. A. Batchelder Making Good

Warren A. Batchelder, who resigned as the Victor manager of the A. M. Hume Music Co. early in the summer to take charge of a branch of the Community Motion Picture Bureau at Newport News, Va., has been making good in his new occupation in a very marked degree. The bureau supplies motion picture films for the soldiers at the front and army cantonments on this side, and Mr. Batchelder has got right into the atmosphere of the work.

H. L. Coombs Getting Settled

H. L. Coombs, mentioned last month as the successor to Oscar W. Ray in the local management of the Emerson Co., has brought his family to Boston and is soon to establish him-

Brunswick Dealers

Our PUR-I-TONE reproducer No. 9 is fitted to machines that have tone arm, with detachable reproducer. Sell this reproducer to your machine customers, as it reproduces an extra smooth quality of sound from ALL lateral cut records. No blast or other extraneous sounds. Write for prices.

NEW ENGLAND TALKING MACHINE CO.

16-18 Beach Street

Boston, Mass.

self in the Back Bay section of the city. Mr. Coombs has just received a large consignment of goods for which he will find ample use among the dealers.

Frank S. Horning New Victor Representative

Frank S. Horning, who is not altogether a stranger to Boston, is now settled in this territory, where he is to be the Victor representative for Boston and vicinity. He succeeds James M. Frye, who is planning to enter service. Mr. Horning has had a long experience with the Victor, and has represented the company at various leading centers, lately being in Chicago, where he had a large territory to look after. For some time following his arrival in town Mr. Horning was bemoaning the loss of a trunk filled with valuable goods which got side-tracked en route, but it turned up in due time, so Mr. Horning was able to don some well-fitting new suits of clothes which he had purchased before coming to Boston.

Add New Lines of Machines

The Iver Johnson Sporting Goods Co., at 155 Washington street, which on its fourth floor conducts a fine talking machine department, is taking on a new line. This department, as the trade well knows, is managed by A. W. Chamberlain, who has been in the business for a number of years, and he is among the best-known men in the local trade and is thoroughly familiar with the technic and mechanics of the business.

Visitors to Columbia Store

R. E. Rea, assistant to the general sales manager of the Columbia Co., spent several days in Boston recently and was entertained by Manager Mann. He came to study the branch office system of this department, which is standardizing its method of handling detail work. As-

Behind the Co-operation

we are now extending in Eastern Victor Service lies the hope, that when the great world war has come to a victorious close we may look back on a period during which we attained a reputation among Victor dealers for giving practical help to them in the solution of their war-time problems.

EASTERN TALKING MACHINE CO.

177 TREMONT STREET

BOSTON, MASS.

Send for Descriptive Circular

Curry DEMONSTRATION BOOTHS
AND RECORD CASES
IN STOCK OR TO ORDER

"SOUND PROOF"

FRANK B. CURRY
19 Wareham St. Boston, Mass.

sistant Manager M. C. Perkins went over to New York this week. This is Mr. Perkins' first visit to the Columbia's executive offices since he associated himself with Manager Mann's headquarters.

Columbia Business Expanding

Manager Fred C. Mann reports the Columbia business for September as an eminently satisfactory one and on the whole his wholesale department is taking very good care of the Columbia dealers. He says that the automatic non-set stop, introduced to the public only a short time ago, is meeting with surprising success and all the dealers are placing large orders for it. Mr. Mann early in the month was away for ten days, going first to New York and then into the western part of this State and sections of New Hampshire and Vermont, where he got a cordial greeting from Victor dealers everywhere. The portions of New Hampshire and Vermont which he visited is territory which recently was turned over to this department and will henceforth be handled from Manager Mann's headquarters.

R. O. Ainslie Perfecting Sales Plans

R. O. Ainslie, of the Pathé line, has mapped out a most comprehensive plan of action for the large field of workers under him and some splendid results should be observed ere long. Lately business has taken quite a spurt and dealers report many promising Pathé prospects.

Combined Business and Pleasure

J. F. Carr, manager of the dealers' service department for the Columbia Co., combined business with pleasure while away a while ago, for, after completing a vacation spent in New York State, he started up into Vermont, where he visited the State Fair at Rutland, at which the United Talking Machine Co. had a creditable exhibit, which resulted in a number of good Columbia sales.

Cheney Phonograph Grows in Favor

The Cheney proposition which Herbert L. Royer has taken for New England has been very well received by the dealers everywhere, and it is Mr. Royer's wish that all who contemplate laying in a stock of these machines make an early application, especially as the local authorities have insisted that the stores begin

The
CHENEY
PHONOGRAPH

"Plays all records better"

Dealers

are invited to inspect this instrument which is so distinctly different from all others.

Attractive agency proposition. Liberal advertising plans.

Write for catalog and full particulars

H. L. ROYER
New England Representative

77 SUMMER STREET, Room 59 - - BOSTON

their Christmas sales earlier than usual. Davis Brothers, who have four large stores, in Boston, Brockton, Lowell and Lawrence, have taken on the Cheney line and are finding it a rather easy thing to introduce it to customers.

New Brunswick Models Admired

Some handsome new Brunswick models have been received at the warerooms of the Brunswick-Balke-Collender Co. which dealers are examining with the closest interest. F. H. Walter has severed his association with the Brunswick department, of which he has been manager, and is considering several good propositions. Mr. Walter made quite a success of the Brunswick proposition while with the house.

Demand is Greater Than the Supply

Manager Silliman, of the Pardee, Ellenberger Co., in Oliver street, says that the demand for the Edison line is far greater than the supply, and the men on the road find no difficulty in keeping the goods going out as fast as they come from the factory. H. R. Skelton, who does a good deal of traveling nowadays for the Edi-

son, is in town this week, making his headquarters at the Pardee, Ellenberger establishment.

Sympathy for C. E. Sheppard

Those in the trade who know C. E. Sheppard, of the Columbia forces, are full of sympathy for him in his bereavement. Both he and his wife and small child have been down with the epidemic, and a few days ago the wife died, and both he and the little one are still seriously ill. The family was face to face with the problem that has had to be met by so many people, the inability of securing a nurse. Mr. Sheppard is one of the valued attaches of Manager Mann's staff, and those of the Columbia force have been doing all they could to lessen Mr. Sheppard's burden.

Remodels Talking Machine Department

Henry L. Kincaide, of Henry L. Kincaide & Co., of Quincy, whose large establishment is known to everybody in that nearby city, has lately remodeled his talking machine department, and under the immediate supervision of

(Continued on page 24)

**— Oldest and Largest
Manufacturers of Talking
Machine Needles in the
World—There are several reasons**

W. H. BAGSHAW CO., Lowell, Mass.

THE TRADE IN BOSTON AND NEW ENGLAND (Continued from page 23)

Miss Mabel Swift it is better than ever before to meet the wants of customers.

Steinert Co. Buys \$50,000 Worth of Bonds

The subscriptions to the Fourth Liberty Loan were considerably enlarged by the generosity and patriotism of the M. Steinert & Sons Co. on October 2, who made a request for \$50,000 worth of the governmental securities. This large subscription immediately focuses attention on this large Boston piano and Victor house and is in line with its attitude toward previous loans.

REMODEL "TALKER" DEPARTMENT

KEENE, N. H., October 1.—G. H. Tilden & Co., of this city, have lately reconstructed their talking machine department so that to-day it is one of the most artistic and convenient places of its kind in the State. In this store there was a basement, apparently quite useless, which to the fertile imagination of the manager struck him as a most desirable place to fit up for the use of his graphophone department. What one sees to-day is little like the neglected basement of old. In one corner is a fireplace and there is everything about the interior that suggests a homey atmosphere. Under better conditions than ever before is the Columbia product brought to the attention of the public. Miss Bertha Mitchell is in charge of the department, and Mr. Kingsbury, who is head of the whole establishment, circularized the city so that everybody now knows of this Columbia headquarters.

A GO-AHEAD SPRINGFIELD DEALER

SPRINGFIELD, VT., October 1.—A talking machine dealer in this town who has rapidly come to the front recently through a clear understanding of the business and a knowledge of how to deal with his public is F. W. Wheeler, of F. H. Wheeler & Son, whose Columbia headquarters has come to be recognized as the rendezvous

of those seeking good music. Mr. Wheeler has very fully equipped his department and he is making many good sales.

CO-OPERATION IN RECORD SALES

How Denholm & McKay Co. Have Developed Their Service on Records in Worcester

The Victrola department of Denholm & McKay Co., Worcester, Mass., is having a very successful fall business, which is due in part, to the large following of record customers they have secured by guaranteeing all records new and unused. They will not exchange or sell on approval, but will gladly play in their large demonstration booths, of which they have nine, any record desired.

The manager, F. E. Russell, is endeavoring to give the best service possible by co-operating with the other dealers in Worcester, in a record exchange of special orders. Once a month each retailer sends a list of records he is unable to secure from the jobber of specials ordered by customers to each of the other retailers. These lists are checked as to what can be filled and returned, then the exchange is made, one for one. This is the only store in Worcester selling a record library plan with machine sales, and this adds practically \$1,000 to their record sales a month.

HAS EDISON AND COLUMBIA LINES

CLAREMONT, N. H., October 1.—Ray Kinne, one of the older Columbia dealers, who is manager of Wheeler's Pharmacy, has given his talking machine department unusual treatment, and the establishment is now admirably adapted to exhibiting and demonstrating both the Columbia and Edison lines, which are carried. J. M. Buzzell, the outside man for this house, is doing a rapidly increasing business.

ILSLEY'S GRAPHITE PHONO SPRING LUBRICANT

Ilsley's Lubricant makes the Motor make good
Is prepared in the proper consistency, will not run out, dry up, or become sticky or rancid. Remains in its original form indefinitely.
Write for special proposition to Jobbers.

MANUFACTURED BY
ILSLEY-DOUBLEDAY & CO., 229-231 Front St., New York
Established 1853

PROGRESSIVE LOUISVILLE STORE

Large Business Built Up by Talking Machine Department of Kaufman-Straus Co. Store—Under Management of H. V. Boswell

The Kaufman-Straus Co., of Louisville, Ky., have, under the management of H. V. Boswell, built up a very large talking machine business



Partial View of Showrooms

which is steadily expanding, thanks to the untiring efforts of all connected with this enterprise from the manager down. The photograph herewith shows only a partial view of the sales section of this establishment.

TO SECURE A REFUND OF TAXES

How to Get Relief in Payment of War Revenue Taxes on Exported Goods

The Treasury Department has recently issued the following information regarding the proper method to pursue to secure a refund of War Revenue taxes paid on goods which have been exported.

The Department says: "Articles sold in foreign commerce under Section 600, sub-division (b), Act of October 3, 1917, are not subject to tax if they are sold direct to the consignee and not through export agents located in the United States and where actually delivered to consignee located in foreign countries.

"In order to recover the amount paid as tax on articles sold in foreign commerce it will be necessary to execute claim for refund Form 46, and furnish the following evidence in connection with such sale:

"(1) An affidavit setting forth the names and addresses of the foreign consignees, together with a statement under oath, if in accordance with the fact, that the goods alleged to have been sold in foreign commerce were sold direct to the consignee mentioned and not to export agents located in the United States, and that the goods were actually delivered to consignees located in foreign countries.

"(2) Copy of invoice covering the goods sold.
"(3) Copy of true bill of lading if such exists, and either a clearing out certificate or ship's receipt showing that the goods were actually shipped for export.

"The evidence called for above should be filed within thirty days, so that the claim may be acted upon promptly."

GOING AFTER THE BUSINESS

F. F. Howard, manager of the R. W. Tyler Co.'s branch store in Clarksburg, W. Va., is featuring the Aeolian-Vocalion phonograph with great success and is using very successfully a large motor truck loaded with phonographs and pianos in order to bring them to the attention of the country folks.

A PERTINENT QUESTION

If everybody said "I'd like to buy some bonds, but—" who would win the war?

MANUFACTURERS— JOBBER—DEALERS



Perfection Universal Tone Arm and Reproducer No. 6 set in position for playing "lateral" cut records.

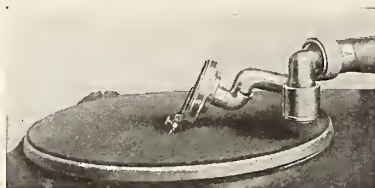

Perfection Universal Tone Arm and Reproducer No. 6 set in position for playing "hill and dale" cut records.

Our PERFECTION line of tone arms and reproducers are now complete and are attachable as follows:

No. 3 tone arm and PUR-I-TONE reproducer plays Victor and Columbia records on Edison Disc Machines.

No. 4 tone arm and Nos. 4, 7 and 8 PUR-I-TONE reproducers play Victor and Columbia records on Edison Disc Machines.

No. 5 tone arm with PUR-I-TONE reproducer plays all makes of hill and dale records on Edison Disc Machines.

No. 6 UNIVERSAL tone arm and PUR-I-TONE reproducer plays ALL makes of records on Edison Disc Machines.

Nos. 3 and 7 PUR-I-TONE reproducers are fitted to Columbia machines for playing Victor and Columbia records.

No. 7 PUR-I-TONE reproducer is fitted to Victor

machines for playing Victor and Columbia records.

No. 11 PUR-I-TONE reproducer plays all makes of hill and dale records on Victor machines.

No. 11-A PUR-I-TONE reproducer plays all makes of hill and dale records on Columbia machines. No. 11 and 11-A reproducers are especially fitted to Victor and Columbia machines, and are easily the finest built in the world. Guaranteed not to blast on any record, and will reproduce Edison Disc records with perfect clarity of sound, also with excellent volume and resonance of sound.

Nos. 9 and 10 UNIVERSAL tone arms with PUR-I-TONE reproducers are fitted to any make phonograph where arm is required that measures 8 inches from center of diaphragm to center of motor board hole.

First-class high-grade product, finely plated and carefully assembled, making this line the leading phonograph accessory line of the world.

Manufactured by

New England Talking Machine Co.

The Largest Manufacturers of Phonograph Accessories in the World
16-18 BEACH STREET BOSTON, MASS.

Write for prices and information as to how these accessories are attached and used on the leading makes of phonographs

BUSINESS IN SAN FRANCISCO IS GOVERNED BY SUPPLIES

Complaints Continue Regarding Shortage of Machines and Records—Mrs. Howard Promoted—California Men in the War—Western Phonograph Co. Expand—New Columbia Manager

SAN FRANCISCO, CAL., October 3.—Several extra holidays, rainy weather and the shortage of standard stock mitigated against business on the Pacific Coast during the month of September, yet the average for the month is fair. Unless supplies come in faster than they have been there will not be as big a fall business as was hoped for. Victor goods cannot be obtained to the full requirements no matter how far ahead the dealer orders. Other lines are not always easy to secure either. The record situation is about on a par with the machine situation. Under the circumstances no special selling campaigns can be inaugurated. There is plenty of money in circulation and no doubt the talking machine business is getting a fair share, but with judicious advertising a much greater business could be done, provided the dealers had complete stocks of machines and records. For a few weeks at least the new Liberty Loan drive will probably have the effect of curtailing purchases. San Francisco will make a great effort to go over the top in record time.

Romance is not a stranger to the business world, not business romance. The elevation of Mrs. Helen Plummer Howard, formerly manager of the talking machine department of the Hauschildt Music Co., Oakland store, to the managership of the whole store does not come as a surprise to those who know Mrs. Howard's special abilities as a business woman. She is said to be the only woman manager of a large music house in the West.

Byron Mauzy, who recently returned from an Eastern trip, and Charles Mauzy, both of whom are loyal Shriners of Islam Temple, marched with their order in the big Liberty Loan parade last week. Byron Mauzy is on the committee of directing captains for the Bond drive, and Charles Mauzy is doing his share on one of the teams also.

The Irvine Music Co. has just received large shipments of Stradivara and Pathé machines. Mr. Irvine says he is pretty well supplied now for the fall trade, but will continue to get new stock in anticipation of the holidays.

The latest representative of the California trade to distinguish himself at the front in France is John MacArthur, who is a lieutenant in the American Aviation Corps. He chased a flock of German flyers who were attacking three American airplanes and succeeded in returning without mishap. He was honored with a medal and the congratulations of General Pershing. Lieut. MacArthur was formerly connected with the talking machine department of the Oakland establishment of Sherman, Clay & Co.

R. E. Wolfinger, formerly of the Emporium talking machine department, has joined the sales force of the Wiley B. Allen talking machine department.

D. Creed, of the Chicago Talking Machine Co., has been visiting his brother at Camp Fremont the past week and has called on some of the local trade.

One of the most popular records in San Francisco at present is Caruso's "Over There." Patriotic records head the list for popularity, yet classic selections are holding their own.

Walter S. Gray is laboring assiduously toward securing needles for his trade. He left last week for a business trip in southern California.

Sinews of war in the form of a quarter of a million of dollars have been secured by the Western Phonograph Co., of San Francisco. This company is now incorporated and will carry on as usual the business of distributing Pathé merchandise to the trade of California, Nevada and Arizona. The new capital will enable the concern to do business on a far more efficient and extended scale than heretofore,

though as it was no grass was growing under the feet of Omer N. Krutsche, the manager. No change in the management is reported, though probably the force will soon be increased.

H. N. McMenimen, managing sales director for the Pathé Co., was in San Francisco during the month on business in connection with the reorganization of the Western Phonograph Co.

The Sonora Phonograph Co. has been much handicapped by employes leaving for the army or war industries. F. B. Travers, the manager, expects to spend some time in the East visiting the factories this month. Conditions at the store have delayed his trip time and again.

Between trying to conciliate customers clamoring for Victor goods and serving on the federal grand jury, Andrew G. McCarthy, treasurer of Sherman, Clay & Co., and manager of the company's talking machine business, is having his hands full. Goods are reshipped as fast as they come from the factory, but the wholesale trade on the Coast is large and the supply is always inadequate.

W. E. Henry, formerly a popular figure in the San Francisco trade, has just been visiting the city. He is now in the foreign record department of the Columbia.

The trade learns with regret that Fred Dennison, Pacific Coast manager of the Columbia Co., is leaving San Francisco. As manager of the company's office at Buffalo he will undoubtedly shed new light and exude vital energy in that quarter as he has done on the Pacific Coast. Nathan Millner, general sales manager of the Dictaphone department, has taken Mr. Dennison's place here.

SHIPS A GRAFONOLA TO AFRICA

B. G. Harriott, a music dealer of Concord, N. H., recently filled an order for a Columbia Grafonola, which he received from Montiba, Central Africa. After its long sea voyage the Grafonola will have to be carried 700 miles inland before it reaches its owner, Ray Crowell, a former Concord boy.

LONG CABINETS



No. 83

In all finishes. Specially adapted for use with Columbia 50, Model "D." Front posts made to follow lines of posts on Columbia 75, Model "F."

FIRST and FOREMOST

In the cabinet field.

Why? Because we've *specialized* in

**CONSTRUCTION
FINISH and
ADAPTABILITY**

Our supremacy in these essentials warrants your handling *the perfect line.*

That's why you should anticipate your wants **NOW.**



No. 79

In all finishes. Shown with top moulding and shelves. Specially adapted for use with Victrola IX-A.

Prompt deliveries on all orders. Write for Illustrated Catalogue of complete line

**THE GEO. A. LONG CABINET COMPANY
HANOVER, PA.**

Three Big Values—Three Big Sellers

Model No. 3
\$125.00

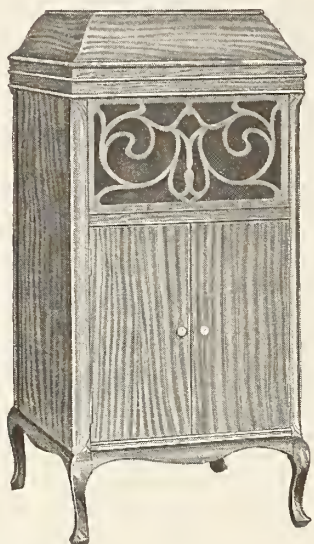

Model No. 6
\$90.00



Model No. 5.
\$75.00



MANDEL PHONOGRAPHS—made by one maker—backed to the limit by the manufacturer, means a service that guarantees your success.

The MANDEL embodies massiveness in cabinet design, efficiency in mechanical construction and richness in tonal quality. These three factors are the making of a good talking machine. And the MANDEL is a good machine.

The three models here illustrated are producing big results for MANDEL dealers. Three popular-priced phonographs—each model giving the consumer greater value for his money than he could ordinarily obtain.

And to the dealer we offer a wonderfully attractive proposition—a co-operative plan that makes it pay him to sell MANDEL Phonographs.

Write for full details—today

A Letter from Missouri—Name and Address on Request

MANDEL MFG. CO.,
Chicago, Ill.

Gentlemen:

Please book my order for immediate shipment by freight, the following:

Two Style No. 3 MANDEL Phonographs, Oak finish.

Two Style No. 3 MANDEL Phonographs, Mahogany finish.

Each purchaser of the MANDEL is delighted with the rich tone value and each sale draws more sales. I sold the last MANDEL today, so please rush out this shipment. I want to keep the MANDEL on my floor. (A MANDEL DEALER)

**MANDEL
MANUFACTURING CO.**

501-511 So. Laflin Street, Chicago, Illinois

No more Workless Windows! Send in today for the Columbia Monthly Dealer Service and put that space to work!

Columbia Graphophone Co.
NEW YORK



NEW EDISON SHOP IN COLORADO

Something of the Men Who Have Made This Colorado Springs Establishment Well Known

COLORADO SPRINGS, COLO., October 3.—The photograph herewith shows the exterior of the New Edison Shop conducted by the Wyckoff brothers at 14 Pikes Peak avenue, this city. The firm is composed of Lieut. H. M. Wyckoff and Kenneth Wyckoff. The former is now in



The Edison Shop in Colorado Springs the U. S. Army and doing special work in Roumania. The New Edison Shop is very attractively fitted up and the photograph shows Mr. and Mrs. Kenneth Wyckoff and Lowell Collins, of the sales force, standing in the doorway. Seated on the pavement is a pet Spitz dog of the firm, who is well known to all Edison customers.

FORMAL OPENING IN CANTON, O.

Klein-Heffelman Co. Open Their Two New Stores Recently Purchased in That City to Take the Place of Burned Building

CANTON, O., October 8.—On September 16 the Klein-Heffelman Co., of this city, formally opened their two new stores recently purchased. This company, it will be recalled, recently lost their entire establishment by fire and for several days were practically out of business until plans were made for the purchase of the Coakly Furniture Co.'s establishment at 125 Fourth street, N. W., and the McConnell Music Co. warerooms at 416 Market avenue. The Klein-Heffelman Co. are large furniture dealers and at their old building had a very elaborate line of pianos, talking machines and other musical instruments. It is stated that the furniture business will be carried on by them at the old Coakly store, while the music department will be represented by them at the McConnell store. Just what the purchase price of both of these stores was has not been stated.

COTTON FLOCKS

.. FOR ..

Record Manufacturing

THE PECKHAM MFG. CO., 238 South Street
NEWARK, N. J.

NEW COLUMBIA CATALOGS

One Devoted to Records and the Other to Grafonolas Just Issued—Both Are Attractively Compiled and Printed

The advertising department of the Columbia Graphophone Co., New York, has just issued two new catalogs, one catalog presenting a complete list of Columbia records and the other the full line of Columbia Grafonolas. Both of these catalogs are attractively compiled and will make welcome additions to the library of Columbia literature.

The record catalog is practically similar to the previous edition except that it contains the recordings of many new artists who have joined the Columbia library within the past year. The growth of the Columbia record library is well evidenced by the increased size of this new catalog, which contains 560 pages as compared with 480 pages in the previous edition. The records are listed and indexed conveniently, so that the dealer and the music-lover may find a particular record under several classifications. These classifications permit of the immediate location of a record where only the artist's name is known or where the class of music is the only guide for selection. The new catalog is typographically artistic and there is the usual tinted section giving a partial list of grand opera and concert selections recorded by famous operatic and concert artists who are numbered among the Columbia Co.'s recording staff.

The new machine catalog features all of the standard Grafonola models, including the following: Type L-2; Type K-2; H-2; G-2; F-2; E-2; D-2; C, B and A. This group comprises the new models that were recently introduced by the Columbia Co. and which are meeting with phenomenal success.

Several pages in this catalog are devoted to the presentation of some of the period design Grafonolas, which are meeting with a ready sale in Columbia establishments throughout the country. Among the art models that are featured in the catalog are the Queen Anne, Charles II, William and Mary and the Adam Grafonola period designs. The photographs of these models are accompanied by excellent descriptions of their distinctive characteristics and the artistic appearance of these instruments accounts for their signal success.

The text of the new Grafonola catalog gives briefly some of the most important instructive features of the Columbia Grafonola, this text calling particular attention to the tone qualities of Columbia records and the Grafonola, and mentioning briefly the needle-arm diaphragm, the non-set automatic stop, the individual record ejector, the "leaves" system of tone control, the new Columbia motor unit, the hinge motor plate, the improved motor frame and the new spring barrel.

This latest Columbia Grafonola catalog gives the story of the Grafonola in a concise and interesting form, and the text as a whole is well worthy of the closest attention.

IMMEDIATE DELIVERIES

Specials

FOR

Victrola IX



809

Mahogany, Golden Oak, Fumed Oak, Weathered Oak, Nickel-plated trimmings. Lock and key. Height, 33 inches. Top, 22 3/4 x 19 1/4 inches. Holds 192 twelve-inch records. Matches new Victrola IX. Highest type of cabinet, both in construction and finish. Average weight crated, 80 lbs.

WE have in stock other cabinets to fit all styles of machines and will be glad to send our catalog for the asking.



702

Mahogany, Golden Oak, Fumed Oak, Weathered Oak, Nickel-plated trimmings. Lock and key. Rubber-tired wheels. Height, 30 inches. Top, 17 x 20 1/2. Matches New Victrola IX. Top has countersunk holes to accommodate rubber humpers on machine. Moulding on top securely fits base of machine. Average weight, crated, 75 lbs.

Schloss Bros.

635-37 West 55th St.
NEW YORK

Phone
Columbus 7947



Time for the opera and concert seasons to begin. Folks will want Columbia operatic records. Are you ready?

**Columbia Graphophone Co.
NEW YORK**

CLEVELAND ASSOCIATION ARRANGING FOR BIG CONCERT

Artists Whose Fame Is Known Through Their Records Will Participate—Hart Piano Co. Absorbed by Harmony Music Shoppe Co.—Business on Higher Plane, Says Dreher—Buying Bonds

CLEVELAND, O., October 6.—The Talking Machine Dealers' Association of Northern Ohio is arranging for a big concert in which artists whose songs and orchestral selections are reproduced on phonograph records will participate. The concert was originally proposed by Charles K. Bennett, president of the association, and others several months ago, but owing to various entertainments given by the Knights of Columbus, the "Y" and other war working organizations the concert promoters gave up their plans.

Now they have taken new headway. At the September gathering of the dealers' association the project was brought up and Grant Smith of the Euclid Music Co., made chairman of the arrangements committee and will report at the meeting of dealers, October 17. This meeting will be the most important gathering of talking machine men since last spring, as winter business, particularly that of the holiday season, will be under discussion.

Talking machine dealers are anxious to close as many deals as possible through the slogan of "Early Shopping," and President Bennett of the association is among those foremost in preaching the doctrine of "Buy Now."

Dealers are still complaining of short shipments of stock from factories and admit that the prospects of better conditions along this line are very, very slim.

Some of the dealers are fairly well stocked, having bought liberally when the sales were not running at their best, the result being an overstock during dull months, but now that the holiday season is soon to begin these dealers consider themselves fortunate in being well supplied with machines and records.

The association members did not go into the Fourth Liberty Loan campaign as a body, but nearly every member is prominent in team work. The city is being canvassed from house to house. The loan drive was opened September 28, former President William Howard Taft being the leading speaker. The next day, Sunday, the city saw the biggest parade in its history. The industrial phase of the parade was declared by Governor James M. Cox, who reviewed it for three hours, to be "the greatest parade of its type it has been my pleasure to see, and I have seen hundreds of marvelous street parades in Washington, New York and other large cities during my public career."

Harlan H. Hart, president of the Cleveland Music Trades Association, and for a quarter of a century identified with the piano business of the city, and dealer in talking machines, has retired from the Hart Piano Co. and the Harmony Music Shoppe. The latter was recently capitalized at \$50,000 and Walter S. Raeder is the company's president, with several former Hart concern and Harmony Shoppe employes in the new concern, which is known as the Harmony Music

Shoppe Co. The quarters of the "shoppe" and the Hart concern, in The Arcade, have been greatly improved, several new talking machine booths having been equipped for patrons. The "shoppe" has taken over the business of the Hart concern and will make a specialty of Victrolas and other high-grade talking machines and records. Player-piano rolls will be a new feature of the establishment. All the officers and employes are well known to the Cleveland and Northern Ohio trade.

Fred A. Krauss, former vice-president of the Hart Piano Co., is the vice-president of the Harmony Music Shoppe Co. Two other men well known to the Cleveland trade are Jacob W. Kegel, secretary, and L. M. Tressel, treasurer of the new company.

The stock of the Goodman Piano Co., recently placed in a receiver's hands, has not yet been disposed of. Many of the \$31,000 worth of instruments listed in the receiver's inventory are talking machines and records. The Goodman concern has a \$100,000 equity in the lease on the building occupied in Huron road. The location is a desirable one, close to that of the Wurlitzer Co.

Harlan H. Hart, former president of the Hart Piano Co., has opened an office in the Permanent Building, Euclid avenue, and is selling pianos and player-pianos. He has not made any public announcement of his future plans, but dealers admit that he "will be heard from" again by the trade.

"More talking machines, pianos, and player-pianos are now being sold than ever before," said Henry Dreher, of B. Dreher's Sons Co. He declared that the recent gathering of Ohio's piano men in Cincinnati showed that their business has been placed upon a higher basis by the war. He said manufacturers of talking machines and other musical instruments are compelled

to sell their output for cash or terms which amount to about the same thing, and dealers in turn have been forced to cut out long time payments on sales.

Charles K. Bennett, manager of the Eclipse Musical Co., distributors and retailers of Victor machines, is a member of the famous "Wrecking Crew" of the Cleveland Athletic Club in the Fourth Liberty Loan campaign. This crew during the Third Loan campaign sold nearly \$2,000,000 worth of bonds, more than \$1,200,000 being sold in one evening at the Keith Hippodrome Theatre.

Caruso's singing of "Over There" has put a whirlwind dash in the sale of Victor records, reproducing his version of the famous song for which its author received \$25,000 cash.

James H. Rogers, Cleveland's leading music critic, in the Plain Dealer, last week, said of this Caruso record: "Now the gifted Italian has made it, through the Victor laboratory, a song to be preserved among the operatic aria records in the cabinets of phonograph lovers. The demand for 'Over There' a la Caruso, at local stores, dealers say, has been large."

The Collister & Sayle Co., Victor dealers, are among the Cleveland firms which have a unique show window display during the Fourth Liberty Loan campaign.

The Brunswick-Balke-Collender Co.'s Cleveland store reports an ever-increasing sale of talking machines with the firm's new reproducing instrument placed on the market last spring. Manager W. F. Young, of the Cleveland office, said the prospects for holiday business are highly encouraging.

Cleveland talking machine dealers point with some degree of pride to the fact that the war has not caused a single failure among members of their organization, if the Goodman Piano Co. be excluded, and the Cleveland Piano Co., which closed out its store September 1 and placed the stock with a concern operating retail stores in East Cleveland and Lakewood. The talking machine dealers have weathered the war period to date in fine shape.



AUTOMATIC STOPS

The simplest and most efficient Automatic Stop on the market. They give excellent service, are easily installed and are absolutely guaranteed.

Send 50 cents for Sample Stop

KIRKMAN ENGINEERING CORPORATION, 237 Lafayette St., New York



UNICO

Designs and Construction
Patented

SYSTEM

THE SALES BUILDER

Unico Demonstrating Rooms
Excel from Every
Standpoint

- DESIGN** Six standard styles
Special period styles
- CONSTRUCTION** Patented, Interlocking
Portable Units
Sound Insulated
- FINISH** All standard Oak,
Mahogany and Enamels
- EFFICIENCY** Increased sales at lower
cost per sale
- ECONOMY** Moderate first cost
Always an Asset
Adaptable any location
- DELIVERY** Prompt shipments from
stock ready for imme-
diate use



Unico Racks and Counters
Maximum Capacity
Minimum Space

- DESIGN** Patented to correspond
with Unico Rooms
- CONSTRUCTION** Sectional Units adapta-
ble to any space
- FINISH** All standard Oak, Ma-
hogany and Enamels
- EFFICIENCY** All records always
available instantly
- ECONOMY** Moderate Equipment
Cost
Lower Operating Cost
- DELIVERY** Prompt shipments from
stock in all finishes

Install a
Complete Unico Department

- U** DEMONSTRATING ROOMS
- N** RECORD RACKS
- I** RECORD COUNTERS
- C** CEILING DECORATIONS
- O** ARCHITECTURE TREATMENTS

The Unico System has
Increased Sales and Profits
for almost 1000 dealers



Send to-day dimensions of your available space. Plans and
estimates for a complete department will reach you promptly

THE UNIT CONSTRUCTION COMPANY

RAYBURN CLARK SMITH, President

Fifty-eighth Street and Grays Avenue, PHILADELPHIA, U. S. A.

A Real Accounting System for Retail Dealers

A Practical System of Accounting for the Use of Music Dealers, Which Can be Adapted to Fit the Needs of Any Business, Large or Small, and Which Will Enable the Dealer to Have Accurate Knowledge of His Stock, Overhead, Resources, Sales and Profits—Devised by Walter Engard, of London, Ohio

It is conservatively estimated that fully 90 per cent. of the business concerns of this country do not know how much money they have made during the current year, nor do they know what it has cost them to do business. The most of them have some kind of a record of receipts and expenditures, and now and then they strike a balance. But it is absolutely necessary for business men to install some accounting method whereby they shall know and not merely guess at such important facts. Keen competition, rising costs and decreasing profits, together with the rapid increase in the business death rate among retail stores, are making it necessary for the retail merchant who wishes to attain success to provide his business with an accurate system of accounting.

This system should be simple, yet accurate and easy to operate. It should be convenient and economical. It should also afford the merchant protection and give all the information necessary to the successful management of his business. The best system for any business is one that will give to the merchant all the information necessary with the least efforts.

I am having reproduced here three ruled forms which go to make up one of the most complete systems of accounting that can be installed, taking care of your business records in the smallest amount of space and requiring but little time. This system is complete in every detail, showing you at the close of each day just how your business stands, also your actual profit for the day.

The first form of this system is known as the "Daily Record of Sales by Departments." This form accommodates the record of the sales in every department of your store, whether it be one or a dozen, by days. At the top of the form on the right space is provided for entering the month for which the record is being kept. On the extreme left it is provided with columns for entering the day of the month and the day of the week. The days of the week, however, are printed right on the form at the time of printing. If the month comes in on Wednesday you start with the first Wednesday that appears on the form and number down the form as 1, 2, 3, 4, etc., skipping the 5th, as this date will be Sunday and every seventh number until you have numbered as many lines as there are working days in the month. If you wish to keep the sale of every article separate then you must provide a space upon this form for as many articles as

stance, you divide your store into six departments; pianos in department A; talking machines in department B; records in department C; sheet music in department D, etc. Now, if a clerk makes a sale of several sheets of music and some records then he will make out two sales slips, one for the music and one for the records, marking the slips for the music department D and the slip for the records department C. The same is true if you should prefer to number your departments in place of lettering them. At the end of the day the bookkeeper will add up the sales of each department and enter in the column pro-

vided for that department, then total the total sales for the store and enter this amount in the total sales column as provided on this form. This form keeps you posted on what is being done in each department every day of the year.

Under the heading "Banking Account" you enter the amount of money deposited that day in the first column and the amount withdrawn

Daily Record of Sales By Departments, Month of ---									
Date	Day	Total Sales			Sales By Departments				
		Cash	Credit	Dep't A	Dep't B	Dep't C	Dep't D		
	Mon								
	Tue								
	Wed								
	Thu								
	Fri								
	Sat								
Total for Week									

This Form Shows What Sales Each Department Is Producing

vided for that department, then total the total sales for the store and enter this amount in the total sales column as provided on this form. This form keeps you posted on what is being done in each department every day of the year.

The second form is the "Daily Record of Cash, Accounts, Profit and Expenses." This form, like the preceding one, provides for the recording of this information daily. In starting in with this form you will need to take an inventory of the amount of cash on hand, the amount of your bank balance, the amount of your accounts payable and accounts receivable; these amounts

that day in the second column. Add the amount of deposits to the balance for the day before and subtract the amount withdrawn and you have the balance of money in the bank at the close of the day. This amount is entered in the third column under this heading and keeps you posted on the condition of your bank account from day to day.

Now under the heading "Accounts Payable" you will enter the amount of goods purchased that day, or rather the total of the invoices for goods purchased which you received that day in the first column and in the second column

S T O C K R E G I S T E R									
Pianos						Talking Machines			
Date of Entry	Stock Numbr.	Make	Descrip-tion	Cost	Selling Price	Date Sold	Date of Entry	Stock Numbr.	
									Extend same rulings
									for talking machines
									as are shown for pianos,
									and continue same for
									records, rolls, or
									other items necessary
									to register for complete
									inventory

A Simple Form of Stock Register, Which Will Furnish an Accurate and Always Up-to-Date Inventory

you carry in stock, and you will have your bookkeeper take the sales of each article off of the sales slips as they come in. But if you divide your store into departments then the salesman will make out separate sales slips for articles sold from the different departments. For in-

are to be centered in their respective columns as provided on this form on the line which reads "Amount Brought Forward." At the end of each day you will enter under the heading "Cash on Hand" the amount of all cash received, including money received on accounts receivable,

you will enter the total amount paid upon these accounts payable plus the discount and any allowances. Adding your amount of accounts payable for the day to the balance for the preceding day and subtracting the amount paid you have the amount of all accounts payable for at

WORLD PHONOGRAPH CO.

MANUFACTURERS

The Instrument of Quality

The "World"

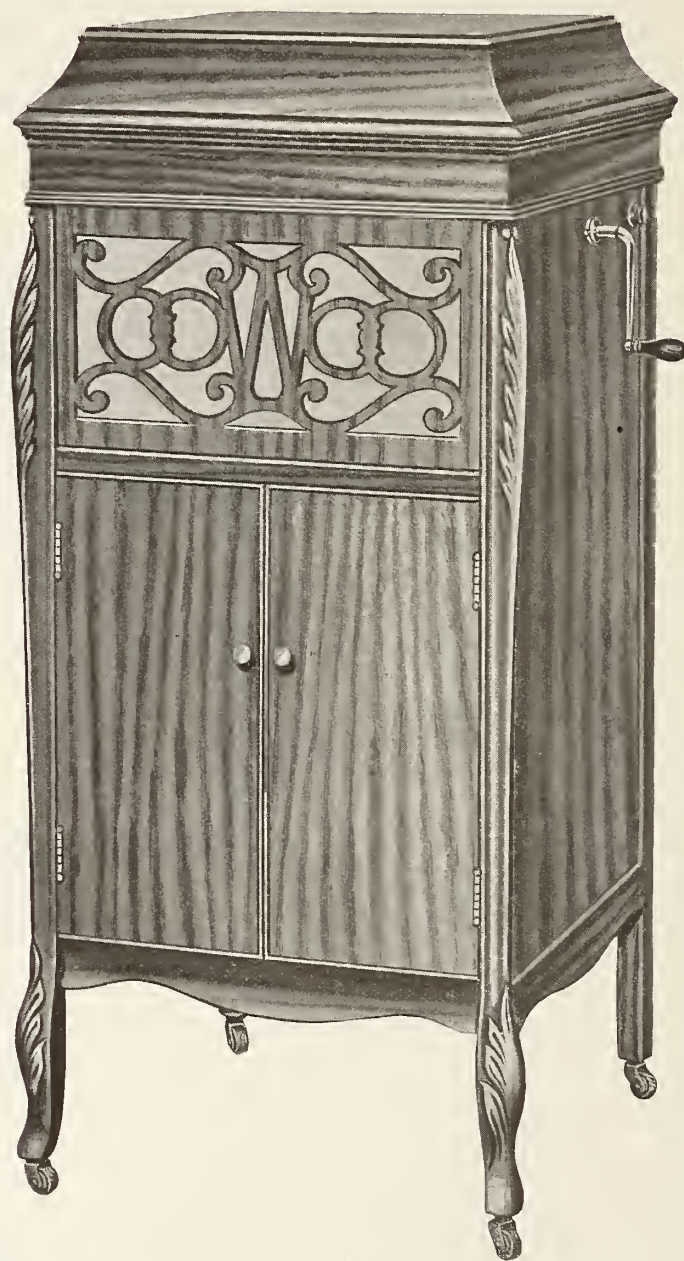

We can take
care of
immediate
wants

Send for
Catalogue

IT PLAYS ALL RECORDS

The "World" Phonograph reproduces the human voice, violin and all other instruments so distinctly that the very personality of the artist is revealed.

The tone and appearance of this instrument endear it to the purchaser so that it becomes a necessity to the home.

Every "World" Phonograph is built by master artisans in our own factory.

Correct design, high-grade construction, durability, appearance and finish are features of the "World" Phonograph.

Manufactured by

WORLD PHONOGRAPH CO.

GENERAL OFFICES AND FACTORY

736-738 TILDEN STREET

CHICAGO, ILL.

Happenings in Dominion of Canada

TALKING MACHINES IN TENTS AT TORONTO EXPOSITION

Manufacturers Display Their Products With Success Despite Unfavorable Circumstances—New Quarters for His Master's Voice, Ltd.—Some General Trade News

TORONTO, CAN., October 5.—At the recent Toronto exhibition the talking machine trade once more accepted the inevitable as far as accommodation was concerned and exhibited in tents or whatever space in a building could be secured. This, of course, does not apply to piano manufacturers who also manufacture talking machines or sell them in their retail departments. An agreement with the Canadian Piano and Organ Manufacturers' Association permitted their appearance with the piano exhibits subject to the regulation that they be demonstrated behind closed doors.

The majority of the talking machine exhibitors, however, were so dissatisfied with the tent proposition that a number of them definitely stated that they would not again so exhibit. They realize that the industry is of such importance and the line one of a status demanding more fitting accommodation than can be provided by a tent. Moreover, the tent with floor, lighting fixtures, decorations, erecting a platform, etc., is expensive. It is not secure against rainstorms as some of the exhibitors found, and the fact that goods were stolen from several of them is still another objection to the tent. A deputation of the talking machine exhibitors interviewed the exhibition management to present their claims for a building. The World understands that a building is likely to be available next year and the inference is that soundproof rooms will be a necessary part of whatever arrangement may be made with the exhibition management.

The number of firms now manufacturing talking machines is impressive evidence of the size and importance of this industry, which has grown almost without those in it realizing what an important factor the business is in the lives of the people. The war and its effects have served to accentuate the hunger of humanity for music whether in the trenches or at home, where there is so much anxiety and sorrow. This universal demand for music along with the improved financial ability of the Canadian people in spite of voluntary and forced contributions to war purposes have caused a marvelous development in public appreciation of music to which the talking machines are responding.

John E. White, a member of the Musical Merchandise Sales Co., Canadian distributors of Brunswick phonographs and records, has moved from Montreal to Toronto so as to be located at the main office. He has secured a competent phonograph man to look after the Eastern branch of the company at Montreal. Owing to the constant increase in business and additional dealers taking on the Brunswick phonograph Mr. White has found it necessary to make Toronto his headquarters.

C. J. Pott, Canadian sales manager for the Otto Heineman Phonograph Supply Co., is authority for the information that arrangements have been completed whereby the Heineman OkeH records will be marketed in Canada.

Miss Ida Gardner and Harold Lyman, Edison tone test artists, have drawn large audiences wherever they have visited and were heard with Edison Re-creations of their own performances. The newspapers in the various Canadian cities visited all gave splendid notices in favor of the New Edison phonograph.

The new Columbia models recently placed on the market have met with great success.

R. S. Williams & Sons Co., Ltd., Edison jobbers, put on a novel stunt at the Toronto Fair that gave them considerable publicity. The idea of the contest was this: You obtained a tag at the Williams exhibit, which was given to any adult. This tag was pinned on the coat

or dress with the numbered side out. As soon as the wearer located the wearer of the tag bearing the same number as his own, both returned to the Williams Edison exhibit and each was the recipient of a prize of Rogers silverware. In addition to the regular prizes, valued at from \$3 to \$5, there was a grand prize of two tea sets of Rogers silverware, each valued at \$25. These tags were distributed from their exhibit throughout the entire duration of the exhibition.

Miss Carter, well known in musical circles in Woodstock, Ont., has been placed in charge of the His Master's Voice department of Heintzman & Co., Ltd., branch in that city.

Pathé Crowlets is the title of a new house organ put out by the Pathé Frères Phonograph Co., of Canada, Ltd.

His Master's Voice, Ltd., Toronto, Ont., distributors of His Master's Voice products, have recently removed to the building a few doors east of their old address on Adelaide street. Just at present they are occupying all the space in the building they can secure, but as soon as other tenants move out in a very short time they will take over the entire three stories and basement of the building. It is most interesting to note that the employees of the statistical department alone of His Master's Voice, Ltd., number more than three times as many as the company's whole staff of seven years ago. The office staff is temporarily located on the second floor, but with the rest of the building available attractive offices and showrooms will be fitted up on the first floor. The feature of importance to His Master's Voice dealers in connection with the removal is that double the stock of records will be carried, making the service still better and still more nearly approximately

the management's ideal of 100 per cent. deliveries. Thos. Nash, manager of His Master's Voice, Ltd., and his able lieutenants are naturally very enthusiastic over the growth of record business, and that the factory output is such as to make it possible to have the stock necessary to fill orders the same day as received.

E. P. Burns, for five years on the selling staff of C. W. Lindsay, Ltd., Kingston, has gone to Ottawa in the capacity of manager of the Phonograph Shop, Ltd. (Edison dealers).

Frank Kisbey, of Prince Albert, Sask., Pathé dealer, recently visited the Pathé Frères factory at Toronto.

C. J. Pott, Canadian sales manager for the Otto Heineman Phonograph Supply Co., New York, has invested in a new Overland car. He has just paid a business visit to the Maritime Provinces.

In the early days of the talking machine the E. J. Coles Co., Woodstock, Ont., were His Master's Voice dealers, but owing to lack of proper facilities for demonstrating the line was discontinued. Now, after a lapse of many years the E. J. Cole Co. have once more taken on the Victor. The firm have established music rooms on the furniture floor of their building. Miss Coleman, a well-known local musician, is in charge.

L. L. Rawson, who for a number of years has been associated with retail houses selling phonographs and until recently with Frank Stanley's Brunswick Shop, Toronto, has been placed in charge of the Brunswick phonograph department of Thomas C. Watkins, Hamilton.

J. R. Errock has arrived in Toronto to take charge of the Canadian factory of the Columbia Graphophone Co., succeeding Mervin Lyle, who, after fifteen years' service with the Columbia Co., goes to Baltimore to take up another line of business.

J. Woods, recently of Heintzman & Co., Ltd., Toronto, has assumed charge of the phonograph department of C. W. Lindsay, Ltd., Ottawa.

MOVE IN CANADA TO HAVE PUBLIC PAY FOR CATALOGS

Rising Cost of Printed Matter Leads Manufacturers to Consider Such a Course—Pathé Artist Gives Interesting Recital—Changes Among the Managers and Salesmen

MONTREAL, CAN., October 5.—When the rising cost of printing, paper, etc., is taken into consideration, as well as the fact that the number of records issued is steadily increasing, it would not be at all unfair for manufacturers of records to ask the public to pay a small sum, say, 25 or 50 cents, for a catalog. The modern record catalog possesses considerable value for the recipient. It is not only a ready reference of records listed, but is a veritable encyclopedia of musical information that cannot be purchased in any similar form.

The time is propitious to approach the public on this matter of fixing a small price for a catalog. While the revenue obtained would in no way recompense the manufacturer for the cost of production, it would help some, and at the same time give him the satisfaction of knowing that every catalog sold would fall into

the hands of those desiring information regarding record purchases. This is a matter that is worthy of consideration by manufacturers and one that should not be overlooked.

Paul Dufault was induced to make a special trip recently to the Montreal recording laboratory of the Berliner Gramophone Co., Ltd., to render his first Victor recordings.

The Royal Piano & Phonograph Co. have opened up exclusive phonograph parlors at 1901 St. Catherine street, East, where they are representing the Columbia and Brunswick lines.

J. Donat Langelier, Ltd., Pointe-Aux Trembles, Que., have put on the market a machine of their own manufacture called the "Disc-O-Phone."

An exclusive Brunswick Shop has been opened at Moncton, N. B.

Arthur K. Kempton, 8 McGill College avenue, (Continued on page 34)

Talking Machine Supplies and Repair Parts

SPRINGS, SOUND BOX PARTS, NEEDLES

THE RENÉ MANUFACTURING CO.
MONTVALE, NEW JERSEY



George Macfarlane—big, jolly, genial George—makes his Columbia debut this month with George Cohan's great hit "When You Come Back."

**Columbia Graphophone Co.
NEW YORK**

TRADE CONDITIONS IN THE DOMINION OF CANADA—(Continued from page 33)

has taken on the Canadian representation of the Disk-Lite, Gloria Cleaner and Golden Tone needles.

Jan Rubini, who records exclusively for the Pathé Co., played a week's engagement at the Princess Theatre with enormous success. All Pathé dealers took advantage of the opportunity to link up their advertising with that of the theatre, the result being a large number of this artist's records were sold.

The visit to Montreal of Giovanni Martinelli, Giuseppe De Luca and Mme. Frances Alda in recital had a wonderful stimulus on the demand for records of these exclusive Victor artists, and all dealers handling His Master's Voice goods shared in the increased demand.

Eugen Ysaye, the Belgian violinist, exclusive Columbia artist, is booked to appear in Montreal shortly.

An interesting recital was recently given at the Phonograph Shop in this city by Jan Rubini, the exclusive Pathé artist. A number of musical people were invited to attend, and the music chamber was well filled. Mr. Rubini's program was rendered with fine effect. An interesting feature of the program was the repetition of these numbers on Pathé records, the perfection of the numbers reproduced surprising many of those present.

The Phonograph Shop has purchased the en-

tire exhibits of Pathé and McLagan phonographs at the Toronto exhibition and now have them on show in their salesroom. In their windows is shown a Pathé Gothic at \$1,200, which has been the means of bringing a lot of customers into the store. This machine was only in the window a few days when a sold sign was attached to it. Aeolian-Vocalion models are meeting with success, and a good demand exists for the records of this make.

The Record Service Library is a newly registered firm doing business in Montreal in the lending of records on a subscription basis.

W. W. Wilder, president of Wilder's Music Supply Co., Starr distributor, passed away suddenly the latter part of September.

Business has been exceptionally good, according to Retail Sales Manager S. H. Brown, of the Berliner Gramophone Co., Ltd., with a heavy percentage of the business in Victor machines being of a spot cash nature. Victor records are in great demand.

L. R. Bourgette, of the selling force of the Musical Merchandise Sales Co., is now representing the Brunswick phonograph and records for Eastern Canada, making his headquarters at Montreal. Mr. Bourgette is now on a trip through the Maritime Provinces.

W. W. O'Hara, for a number of years associated with the house of Layton Bros., latterly as sales manager, has started business for himself at 736 St. Catherine street, West, where he will handle the complete Columbia line. His many years' experience should give him a good following. He is one of the younger generation and has the ability to make good on his own account.

RECITAL IN THE PROVINCES

Miss Morrisey and Joel Belov Give Tone Test Recital in Leading Cities in New Brunswick and Nova Scotia

St. JOHN, N. B., October 2.—W. H. Thorne & Co., Ltd., Eastern Canada jobbers of the Edison line, recently arranged for a series of tone test recitals which were given by Miss Marie Morrisey, contralto, and Joel Belov, violinist, who appeared in Fredericton, St. John, New Glasgow, Sydney, Glace Bay, Halifax, Bridgewater, Windsor, Kentville and Truro, between September 23 and October 4. While in Fredericton Miss Morrisey, in addition to the regular recital, was good enough to sing for a number of returned and disabled soldiers in the hospitals there and her kindness was much appreciated. In St. John a twilight recital was given in the Imperial Theatre at 4.30, before a large and most enthusiastic audience.

"I thought you couldn't get credit any more?" "I couldn't for a while. But since scientific salesmanship came in I amble around and let the scientific salesmen sell me some delightfully large bills."—Kansas City Journal.

TRADE BRIEFLETS FROM WINNIPEG

WINNIPEG, MAN., October 4.—The Lodge Piano House in Edmonton, Alta., has been appointed agent for His Master's Voice records.

The Imperial Phonograph Co. had an exhibit of Columbia lines at the recent Calgary exhibition.

Robert Shaw, of the Grafonola department of Cassidy's, Ltd., is at present traveling in the West with a special representative of the Columbia factory. He reports business good with prospects even better for trade this season.

Babson Bros., Edison dealers, say business is looking up and the prospects are good for a normal fall trade.

The Fowler Piano Co. have taken on the Victor record representation, also the Brunswick phonograph. Mr. Fowler has been in New York on an extended purchasing trip.

The Western Gramophone Co., Ltd., report Victor business very good with a particularly good season ahead.

The Phonograph Shop, Ltd., is handling Brunswick phonographs and records as well as Columbia machines and records.

Chopin Phonographs, Ltd., Winnipeg, have enlarged their offices and plant. John Robson, a phonograph man of over twenty-six years' experience, has linked up with this organization.

VANCOUVER TRADE HAPPENINGS.

VANCOUVER, B. C., October 3.—The Vancouver Music Dealers' Association, while comparatively a young organization, has been doing some very effective work, and has among other things agreed on the retail price of talking machine needles and other matters of general trade interest.

Townley & Ward have opened up a handsome store on Hastings street, where they are showing a full Columbia line.

Fletcher Bros. report Sonora and Columbia sales as steadily expanding.

Darley Kent, of Victoria, was a recent visitor to the Edison plant at Orange, N. J. This store has recently been featuring Edison record advertising to good purpose.

EDISON LINE AT STATE FAIR

A very attractive display of the Edison Diamond Disc phonograph and the Edison Amberola was housed in a special booth in the Exposition Building at the State Fair recently held in Wheeling, W. Va. Demonstrations of both types of machines were given at frequent intervals, the display being in charge of J. C. Dilts.

YOU CAN DO YOUR BIT

You may not be able to do as much for the new Victory Loan as Foch and Pershing are, but you can do yours just the same.

"The Music Without the Blur!"

This ideal of talking machine manufacture is attained more nearly than by any other, in the construction of the

MARVELOUS MAGNOLA "Built by Tone Specialists"

"Magnola's Tone Deflector eliminates the scratch"



Watching the Music Come Out

We want to show you how to make money with MAGNOLA; and how MAGNOLA is the best buy on the Talking Machine Market to-day.

Send us your name and let us send you some real Talker Tips.

MAGNOLA TALKING MACHINE COMPANY

OTTO SCHULZ, President

General Offices Southern Wholesale Branch
711 MILWAUKEE AVENUE 1530 CANDLER BLDG.
CHICAGO ATLANTA, GA.

NEEDLES

Manufactured by the

DEAN DIVISION

of the

OTTO HEINEMAN PHONOGRAPH SUPPLY CO.

INCORPORATED

25 WEST 45th STREET, NEW YORK

FACTORIES: Elyria, Ohio	Newark, N. J.	Putnam, Conn.	Springfield, Mass.
BRANCH OFFICES:	Chicago, Ill.	Seattle, Wash.	Toronto, Ont.

STEEL NEEDLES

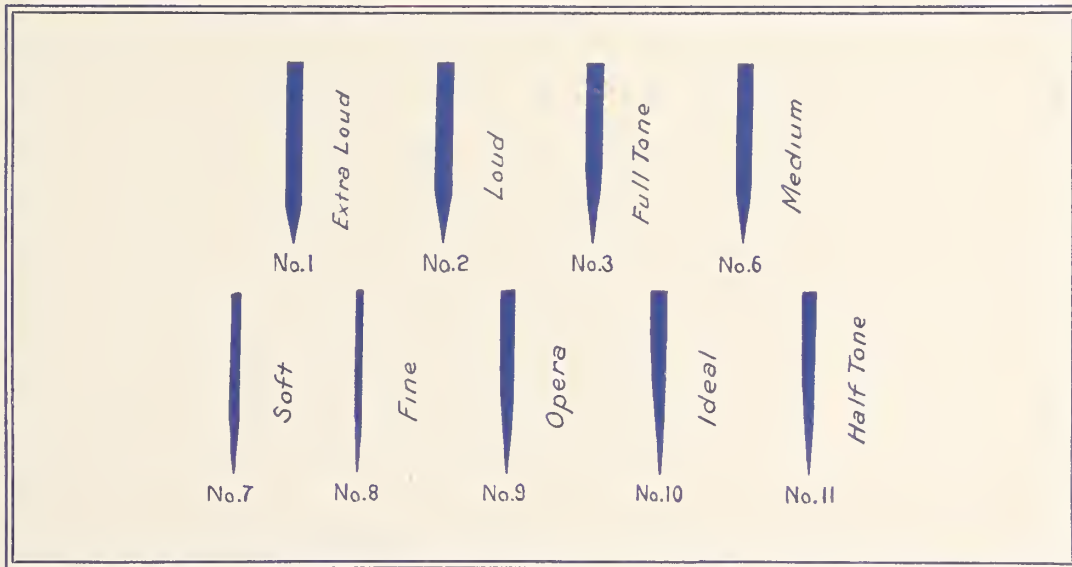

PERMANENT NEEDLES

TO PLAY PATHÉ RECORDS

Half Tone Points

Full Tone Points

TO PLAY EDISON RECORDS

Sapphire Points

Genuine Diamond Points





Featuring the Musical Possibilities of the Talking Machine

By William Braid White

[Note.—This is the twentieth in a series of articles on the general subject of the musical possibilities of the talking machine. The aim of the series is to develop these possibilities from all angles, thus opening up fields for sales expansion oftentimes neglected wholly or in part.—Editor.]

“ALLIED” MUSIC AND THE WAR

In the opinion of those who are best qualified to judge, the present time presents an opportunity unsurpassed for putting up to the American people some of the musical lessons they will have to learn during the coming years. When the unconditional surrender, which constitutes the Allied peace conditions, has been offered by the beaten Hun there will undoubtedly begin a period of much economic and political importance, during which many world-embracing policies must be carried out by the Allied nations. It will be necessary for an entente cordiale between these nations, France, Belgium, Great Britain, the British Empire, Italy, Serbia and the United States, not merely to be promulgated, but to be lived up to as cordially as the name itself implies; if, indeed, we are to bring about that reconstruction of the world upon a new and enduring basis of peace and harmony which we all profess to desire.

Amongst the most important of the tasks which will confront the world during this time will be that of inducing the Americans to reverse their previous attitude toward the other nations and co-operate cordially and sincerely with them in the general work of rebuilding.

Promoting the Entente

The difficulty will not so much refer to the intention as to the action. The American people are making great sacrifices already in the common cause, and are ready to make more, until their own have equaled those of their Allies; but this is not all. A better understanding of the French and British points of view especially, as well as of the wholly new ideas that are already being brought into view through the emergence of the long-suppressed Czechoslovak and Jugo-Slav nationalities, will be absolutely necessary to any people which takes a part in the coming reconstruction of the world. The American people are as much behind as are any other peoples in an understanding of and sympathy with their neighbors' points of view. A common culture is, however, the surest road to such understanding and sympathy. Does not music provide the simplest, most easily understood and most effective means toward the realization of such a culture?

Not to be pedantic about it, one can plainly see that those who, like the dealers in music and musical instruments, have so much responsibility for the formation of public taste, have a great and patriotic opportunity. They can now begin in a modest and unobtrusive manner without seeming to appear to educate their customers, the great task of demonstrating the desirability and attractiveness of the music which is native to our various Allies; to the British, French, Italian and Slavic peoples. Some of the finest music in the world will thus be brought to the front and made known to millions who have been strangers to it.

Our Propaganda

At the present moment everything is in train for a far-reaching and effective propaganda in favor of the music of ourselves and of our Allies. When I speak of our own music I am not referring to the kind of stuff that unhappily has come to be known as “American.” In a recent circular addressed to members the president of the National Federation of Musical Clubs asks for co-operation in the great task of supplying to the army and navy music of all sorts, instancing especially talking machine records and talking machines. In this very circular, however, the point is made that vulgar

popular music is not wanted, while it is a well-known fact that the chief worker for the National Federation of Musical Clubs in this matter of war music distribution is herself one of the principal workers for the cause of allied music.

Whilst our soldiers and sailors are learning the worth and beauty of the French, Italian and British civilizations at first hand it would not only be patriotic and wise, but eminently practical, in my opinion, for us at home to inaugurate campaigns through the medium of the talking machine for the cultivation of the music of these lands. In last month's Talking Machine World I took the liberty of pointing to some of the absurdities which have passed current in this country, as the result of German propaganda, concerning the artistic rank of the non-German peoples. It is not possible for us to teach the whole mass of the people the entire truth about the Hun lies; but it is quite possible for us to teach them the truth, to some extent, about the music of themselves and of their Allies, to the end that they may come to understand how they have consistently underestimated what is good and overestimated what has often been brutally ugly. It is a great opportunity for every talking machine man to do good patriotic and also good practical commercial work.

British Music

Only those who have been taught wrong from the first would for a moment run away with the notion that the British are not a musical people. The idea has all the earmarks of the Hun. The fact is that the British people, like the American people, are too wise to take themselves with the profound seriousness which has been the curse, and soon will have accomplished the entire ruin, of the Hun and of all his works. They take their music lightly; too lightly, indeed; but that does not mean they are unmusical. In point of fact, during the past fifty years the progress of music in the British Isles has been marvelous. Two hundred years ago a flourishing British school of composition was coming to its close, to be overwhelmed by the Germanizing tendencies and the Italian opera of the eighteenth century. Yet this school of music

is not only respectable; it was wonderful. The names of such men as Henry Purcell, Blow, Gibbons and Cook rise to the mind, and we remember that some of the noblest of songs have come from their pens, such as the setting to Milton's St. Cecilia Ode.

After all, a nation that seven hundred years ago could produce that extraordinary piece of musical composition, “Sumer is icumen in,” a work far above anything else contemporary that has yet been discovered, cannot have been so very unmusical. Nor does a fair examination of the facts as they exist today justify the supposition that the British people are compelled, through any defects of capacity, to borrow their musical ideas from abroad.

British talking machine records are not perhaps as numerous as one might wish, but at that one may find a fair number of them by searching the catalogs. It would be a very good notion to put on a series of “Allied” music days, offering a continuous recital during each day of the music appropriate to the nation represented. For the British program we might suggest a few titles as follows:

National Songs—“God Save the King”; “Rule Britannia”; “The Roast Beef of Old England”; “Sally in Our Alley”; “British Grenadiers.”

National Folk Songs—“Asleep in the Deep”; “Girl I Left Behind Me”; “Drink to Me Only with Thine Eyes”; “Under the Greenwood Tree”; “Here's to the Maiden of Sweet Sixteen,” etc.

Scottish Songs—“Ye Banks and Braes”; “Afton Water”; “My Ain Countree”; “Scots, Wha' Hae wi' Wallace Bled”; “Hail to the Chief.”

Welsh Songs—“Men of Harlech”; “All Through the Night”; “Mentra Gwen,” etc.

In addition to these songs are many splendid military marches, such as Elgar's “Pomp and Circumstance,” and others which are listed. Some of these, sprinkled through a British song recital program, would lighten things up and make a very attractive proposition altogether.

These, of course, are bare suggestions, but it should not be overlooked that they have a deeper significance. The successful outcome of

(Continued on page 37)

7th Floor

229 Fulton Street

Clifford A. Wolf

MANUFACTURER OF

Diamond and Sapphire
Phonograph Points

New York City

Phone, 1678 Cortlandt

Mr. Dealer: Have you received our special Holiday offer and our new eighteen-page Catalog?

The Soul of Music Dwells Within

Both are FREE—Each is Valuable! May we send them to you?



Tel-o-Tone De Luxe \$200

A "TEL-O-TONE" Agency is a MERCHANDISING ASSET with an established Rating.

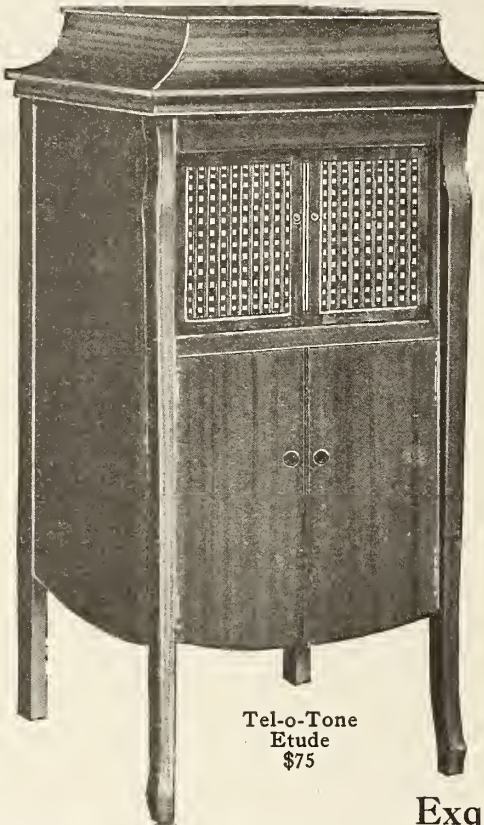

Tel-o-Tone Etude \$75

The True-to-Life Tone

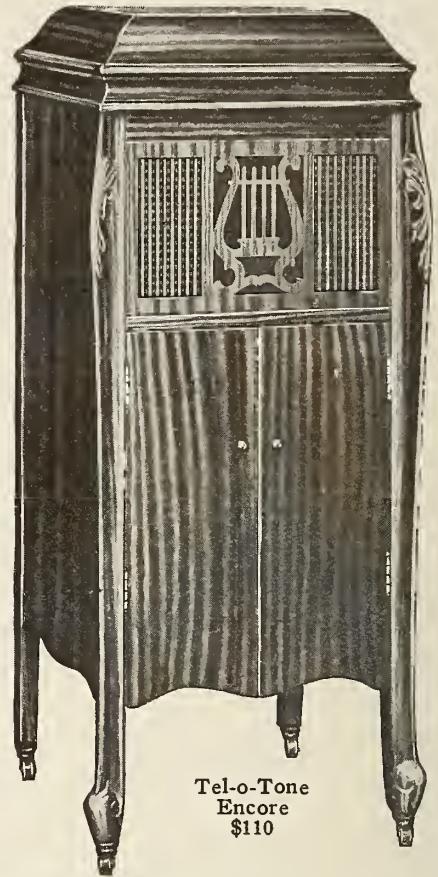

Tel-o-Tone Encore \$110

Sings "Everything in Music"

Exquisite "Tone-Personality"

HEADQUARTERS 86th DIVISION, N.A.

Camp Grant, Ill. April 19, 1915.

To Whom It May Concern:

I purchased one of the first Tel O Tone instruments placed on the market. This phonograph is still giving complete satisfaction and has had very hard use and treatment. I also secured later one of the large size instruments of the same general construction and I have never found a superior instrument either in quality of tone or construction. In my opinion, the Tel O Tone instrument ranks with any instrument on the market so far as musical producing quality is concerned, and I do not believe that there is as good an instrument for the price on the market today.

With loving remembrance Captain, Infantry, P.C.

(Former Sub-Treasurer U.S.A.-Chicago)

Now is the time to secure an Agency

The "TEL-O-TONE" is claimed to be the "WORLD'S GREATEST MUSICAL INSTRUMENT." The Tone Supreme, within Cabinets of Superb Individuality, the Superiority of which CANNOT BE CHALLENGED! We Guarantee Every Instrument.

This is a LIVE DEALER'S Proposition—ARE YOU THAT MAN?



Tel-o-Tone Matinee \$85

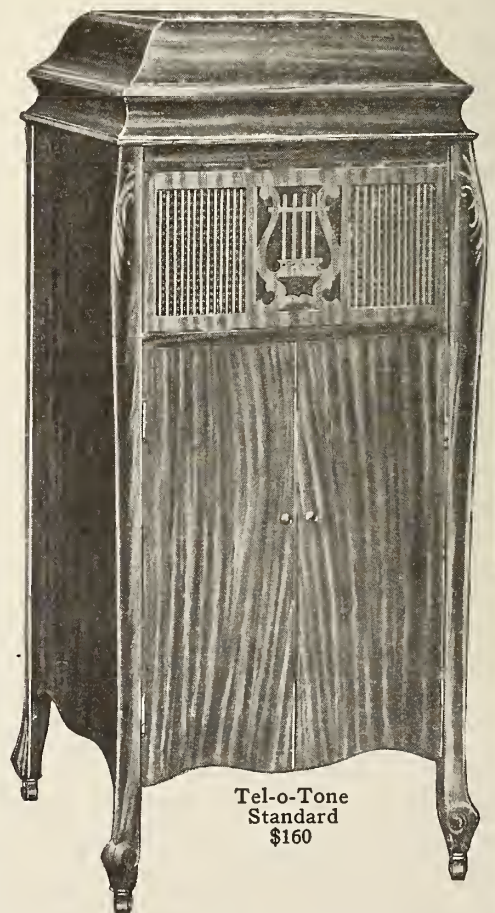

Tel-o-Tone Standard \$160

We can supply the goods, why not order our samples? (We will not take on more customers than we can supply promptly.) We are yet prepared to include a limited number of good Dealers in our out-put allotment for 1918. DON'T DELAY! Write or wire us at once.

The Western News Company, 21-29 East Austin Ave., Chicago, Ill. RETAIL DISPLAY ROOM: 730 Republic Building, State and Adams Streets, Chicago, Ill., U. S. A.

"ALLIED" MUSIC AND THE WAR
(Continued from page 35)

the war, which means the complete military defeat and unconditional surrender of the German and Austro-Hungarian Empires, is not yet attained, although it is on the road to being attained. It cannot be put aside by any conceivable combinations of circumstances, save one; and that would be any lack of co-operation and cordiality among our Allies and ourselves. The coming critical months will demand of us all we can give of such sympathy and co-operation. The more we understand and appreciate the civilization, the home life and the ideals of our British Allies, who carry the major burden of the war, the better we shall do our work. Let every talking machine man do his best to bring his circle of customers into better touch with British music.

HEINEMAN EMPLOYEES SCORE RECORD

Every Employee in Otto Heineman Phonograph Supply Co. Buys Liberty Bonds—100 Per Cent. Flag for the House Ordered

Every employe in the Otto Heineman Phonograph Supply Co. is now wearing a Fourth Liberty Loan button, indicating that this house has achieved a 100 per cent. record in the Fourth Liberty Loan drive. A 100 per cent. flag has been ordered, and Otto Heineman, president of the company, is naturally delighted to have the honor of displaying this flag.

The company, in order to evidence its appreciation of the service rendered by its employes, has made arrangements whereby the employe in purchasing these Liberty Bonds will pay a stipulated amount one week and the company will pay the same amount on alternate weeks. In other words, a \$50 bond will cost the employe only \$25, and larger bonds in proportion. This generous spirit is greatly appreciated by the Heineman employes, who subscribed to the limit and then bought more.

The Pioneer Piano House, of Eureka, Cal., is carrying some very effective publicity in the local papers in which, in addition to referring to its piano line, it says: "Music prolongs life. The more you hear it the longer you will live. It is good medicine. The doctor recommends it, be it from a piano, Victrola or Sonora."

What More Can You Ask

All the features that go to make a talking machine *Profitably Salable* you will find as regular equipment of *Magnola*: "Built by Tone Specialists."

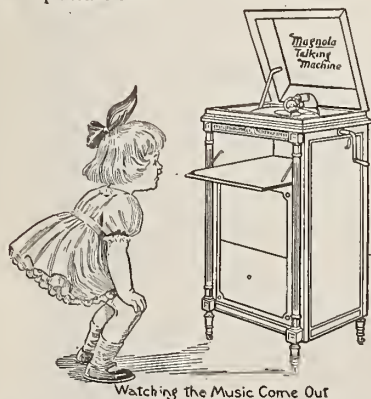

Watching the Music Come Out

Complete description of all these features is to be found in our *handsome illustrated catalog*, which we should like to send you. May we? Ask us to tell you our plans for your benefit!

MAGNOLA TALKING MACHINE COMPANY
OTTO SCHULZ, President
General Offices: 711 MILWAUKEE AVENUE CHICAGO
Southern Wholesale Branch: 1530 CANDLER BLDG. ATLANTA, GA.

LEASES FIVE-STORY BUILDING

The Lucky 13 Phonograph Co. Leases Entire Structure at 46 East Twelfth Street, New York, Where Its Executive Offices and Ware-rooms Will Be Located—Business Expanding

The Lucky 13 Phonograph Co., manufacturer of the Cleartone talking machine and distributors of phonograph parts, etc., has recently leased the entire five-story building at 46 East Twelfth street, New York, where its executive offices and warerooms will be located. For several years past the company has been located at 3 West Twelfth street, New York, but its fast growing business necessitated the leasing of new quarters in order to accommodate the demands of its clientele.

The building at 46 East Twelfth street is ideally adapted for the concern's expanding business, as it is located only one door from Broadway and affords ideal transit facilities. The company will occupy the entire building, and D. Bartelstone, president of the Lucky 13 Phonograph Co., is making plans whereby efficient service and co-operation will be an important factor in the company's plans during the coming year.

The Cleartone talking machine, although it has been on the market only a comparatively short while, is now being sold by representative dealers throughout the country, and Mr. Bartelstone, realizing that merchandise will be abnormally scarce this fall, anticipated this shortage by placing large advance orders with his cabinet factory the early part of the year. As a result of this foresight he is in a position to supply the demands of his dealers promptly, and with the new wareroom space at his disposal expects to close a record-breaking business this fall.

WILL HOLD ITS ANNUAL GATHERING

Sonora Department of the Yahr & Lange Drug Co. Will Entertain State Dealers at Convention on October 23—Big Attendance Expected

MILWAUKEE, Wis., October 5.—The Sonora department of the Yahr & Lange Drug Co., Sonora distributors in this territory, will hold its annual convention in Milwaukee on October 23. The morning session will be called at 10.30, consisting of a reception and meeting of the State dealers. At 2.30 in the afternoon a business meeting will take place, and a banquet will be held in the evening at the Milwaukee Athletic Club.

The officials of the company hope that George E. Brightson, president of the Sonora Phonograph Sales Co., or Frank E. Coupe, director of sales and publicity for this company, will visit Milwaukee this month to welcome Wisconsin and Upper Michigan dealers. The first Sonora dealers' convention held under the auspices of the Yahr & Lange Drug Co. was a signal success, and it is expected that this second convention will emphasize and reflect the spirit of co-operation and good will that exists between this successful jobber and its dealers.

NEW MURATORE WINDOW CARD

A new window card featuring Lucien Muratore, the famous tenor, has recently been prepared by the advertising department of the Pathé Frères Co. for the use of Pathé dealers. This card was mailed to Pathé representatives last week and is now on display throughout the country.

Lucien Muratore, who is one of the world's leading tenors, records exclusively for the Pathé record library, and his records have won commendation from musical critics everywhere. The Pathé Frères Co. has co-operated with its dealers in featuring the records of this famous artist, and this new window card is the latest link in this effective publicity campaign.

A promising future is almost as hard to catch up with as are our good intentions.

**The
Scotford Tonearm
and
Superior Universal
Reproducer**

*The Ideal
Combination*

*Plays All Makes of Records
as they should be played*

Price of Sample Prepaid
Nickel, \$5.25 Gold, \$6.50

Adjusted for Cabinet
measuring 8 1/2 inches from center of Tonearm
base to center of Turntable shaft

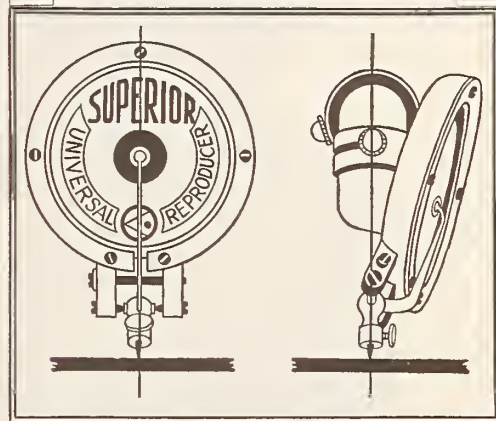

Distinctive Features

The Reproducer pivots on its axis (as illustrated above), taking the correct angle for all makes of records, and the needle retains same center in both positions.

Surface noise is less than with any other reproducer—surface scratchings being reduced to a minimum through perfect proportioning of the stylus construction, and placing the needle in the center of the groove at the correct angle.

The split construction of the frame and face ring of the Reproducer, together with the method of pivoting the stylus bar, and perfect insulation—effect a sensitive and free vibration—and prevent a pinched tone resulting at any time from natural contraction or expansion of the metal parts.

The reproduction is the mellow, natural quality of tone—absolutely getting away from the usual sharpness and metallic effect so noticeable in most reproducers.

Sound waves act upon the same principle as light waves—they travel in a straight line until they meet some obstruction, from which they are deflected at right angles. The right angle turn at the back of the Scotford Tonearm causes less breaking up and confusion of the sound waves than occurs in the curved arm.

The connection between the Reproducer and Tonearm is perfectly insulated with a hard rubber bushing. Inside diameter of the Tonearm is correct to accommodate the volume obtained from the latest records.

The right-side turn for changing needle is handier than the old style turn-back, and when in position for the Hill-and-Dale records there is no interference with lowering the cabinet cover.

The lateral movement at the base is simple, free and permanently satisfactory. Inside there is no obstruction to interfere with passage of the sound waves. There are no loose balls in the bearings, therefore no buzzing noise can occur from the great vibration on high notes.



**Barnhart Brothers
& Spindler**

Monroe and Throop Streets—Chicago

The most wonderful Talking Machine of the present age at the price
An Instrument of Supreme Value, Tone and Quality

Clearstone

SPEAKS FOR ITSELF



No. 100—\$100



No. 75—\$75

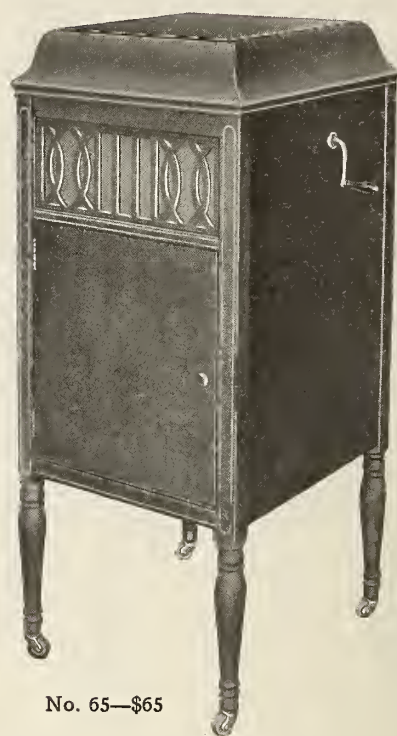

No. 65—\$65

The *Clearstone* has become very popular because of its quality, splendid value and the advertising and sales campaign that now stands in back of it. **Dealers!** Watch us grow—write for our agency and grow with us.

SUNDRY DEPARTMENT

MOTORS—No. 1, double-spring, 10-inch turntable, plays 2 10-inch records, \$3.25; No. 6, double-spring 10-inch turntable, plays 3 10-inch records, \$4.00, with 12-inch turntable, \$4.25; No. 8, double-spring, 12-inch turntable, plays 3 10-inch records, castiron frame, \$5.85; No. 9, double-spring, 12-inch turntable, plays 3 10-inch records, castiron frame, bevel gear wind, \$6.85; No. 10, double-spring, 12-inch turntable, plays 4 10-inch records, castiron frame, bevel gear wind, \$7.85; No. 11, double-spring, 12-inch turntable, plays 7 10-inch records, castiron frame, bevel gear wind, \$9.75.

TONE ARMS AND REPRODUCERS—Play all records—No. 2, \$1.45 per set; No. 4, \$3.95 per set; No. 6, \$3.75 per set; No. 7, \$3.75 per set; No. 8, \$3.75 per set; No. 9, \$3.25 per set.

MAIN SPRINGS—No. 00, 5/8 in., 9 ft., 39c. each; No. 01, 3/4 in., 7 ft., 29c. each; No. 1, 3/4 in., 10 ft., 49c. each; No. 2, 1 1/8 in., 10 ft., 49c. each; No. 3, 7/8 in., 11 ft., 59c. each; No. 4, 1 in., 10 ft., 59c. each; No. 5, 1 in., 11 ft., heavy, 75c. each; No. 6, 1 1/4 in., 11 ft., 95c. each. We also carry other size main springs to fit Victor, Columbia and all other motors at nominal prices.

RECORDS—POPULAR AND GRAMMAVOX, new 10-inch, double-disc, lateral cut, all instrumental selections 35c. each.

GOVERNOR SPRINGS—To fit VICTOR, COLUMBIA and all other motors at moderate prices. Special prices on large quantities to Motor Manufacturers.

GENUINE DIAMOND POINTS, for playing Edison records, \$1.75 each.

SAPPHIRE POINTS, for playing Edison records, 18c. each.

SAPPHIRE BALLS, for playing Pathé records, 22c. each.

NEEDLES, steel, 75c. per thousand in 10,000 lot.

We also manufacture special machine parts, such as worm gears, stampings, or any screw machine parts for motor, reproducer and part manufacturers.

Special quotations given to quantity buyers in Canada and other export points.

Write for our 84-page catalog, the only one of its kind in America, illustrating 33 different styles of talking machines and over 500 different phonographic parts, also gives description of our efficient Repair Department.



No. 85—\$85

Lucky 13 Phonograph Co., 46 East 12th St., New York

Lashanska, Maurel, Seagle, Stiles, Gates, and a host of other Columbia artists start their concerts soon. That means increased demand for their records.

**Columbia Graphophone Co.
NEW YORK**



THE VALUE OF THE WINDOW AS A FACTOR IN ADVERTISING

Dealers of Middle West Meet in Cincinnati as Guests of Phonograph Co. to Discuss Subject—Rudolph Dittrich Resigns From Wurlitzer's—Recent Additions to Vocalion Staff—Other News

CINCINNATI, O., October 5.—Live ideas in advertising, notably of the window character, in view of the times, was brought to the attention of the dealers of the Phonograph Co. in the Middle West, who assembled in Cincinnati today. The visitors, numbering more than thirty, were entertained by E. H. Oelman, Cincinnati manager of the Edison line. He explained the new regulations of the Government on the decreased production of machines and pointed out how the retailers could help the public under the new arrangement.

Mr. Fogarty, representing the Gundlach Advertising Co., Chicago, gave a talk along publicity lines. A feature of the gathering was an exhibit of window displays by Ellis Hansen & Co., also of the Windy City.

Among those present were: Richard A. McKee, Charleston, W. Va.; M. N. Billings, Chillicothe, O.; J. O. Smucker, Bellefontaine, O.; T. W. Bradley, Bluefield, W. Va.; E. J. Stevens, Middletown, O.; Adolph Lehne, Mechanicsburg, O.; Leslie I. King, Columbus, O.; Warren Spring, Eaton, O.; Sherman Balyeat, Van Wert, O.; J. T. Kackley, Maysville, Ky.; A. F. Hibbard, Athens, O.; W. E. Summers, Washington C. H., O.; Geo. Krebs, Hamilton, O.; F. R. Follis, Dayton, O.; A. T. Fitzwater, Cynthiana, Ky.; W. M. Walker, Wilmington, O.; A. F. Wheeler, Lexington, Ky.; Ferd Imfeld, Hamilton, O.; C. H. Hutchison, Ripley, O.; W. V. Tennant, Middlesboro, Ky.; Greenfield Piano Co., Greenfield, O.; W. S. Thomas, Richwood, W. Va.; J. W. Thompson, Oak Hill, W. Va.; Sawhill-Dolbeer Co., Springfield, O.; C. H. Wadlington, Shelbyville, Ky.; G. A. Frentzel, Woodmansee Piano Co., Geo. H. Link, George P. Gross, E. Henlein (Alms & Doepke), all of Cincinnati, O.

The recent convention of the Ohio Association of Piano Merchants held in Cincinnati took on quite a phonographic tinge. Dealers in these lines, more so the jobbers, took advantage of the meeting and looked up customers as well as prospects in the trade.

Rudolph Dittrich, for sixteen years at the head of the Victrola department of the Rudolph Wurlitzer Co., at last has realized his hopes of years and has become a farmer. He possessed farmland over in Kentucky, which he has been operating for some years, but always wished to give his entire time to the proposition. Mr. Dittrich has been in the talking machine field since its infancy and grew up with the Victrola's growth in the Cincinnati district. He has been succeeded by T. F. Sigman, who had been his right-hand assistant for five years. Mr. Sigman's views on the developments of the past month from a Victor standpoint follows:

"While the business for September was not quite as good as it should have been, a very creditable showing was made, both in our wholesale and retail departments, when you consider

conditions. One of the features of the month was our taking a list of 100 records that were good sellers with the exception that they had been practically lost in the large record catalog, and each week we would pick out twenty-five of these numbers, make a counter display, window display, and also put them in albums in the various record rooms. Every customer that came in could see the records on display, and the salesladies would play some of these records for every customer that came in to the store. This naturally sold a number of these records, and we expect to continue in this way for some little time until we are able to dispose of our surplus stock.

"The smaller Victrolas, such as the No. 4's and No. 6's, and the larger types, such as the No. 17's, have been selling both wholesale and retail, for these are about the only machines that we are able to get, due to the fact that the other types are very slow in coming through from the factory.

"We are working hard on the Liberty Loan here, but we believe that there will still be some room for good business during October."

C. L. Byars, of the local Aeolian store, reports a satisfactory Vocalion business for the month of September. He regrets the loss of the services of E. M. Hacker, who has been as-

sociated with him in the sale of Vocalions for the last three years, and who has recently accepted a position as inspector with the Good-year Tire & Rubber Co., Akron, O. Mr. Hacker was a very successful Vocalion salesman, and he will be missed in the Vocalion line-up.

John F. McCarthy, for three years salesman for the Union Central Life Insurance Co., of this city, has just severed his connection with that company and enlisted in the ranks of the Vocalion sales force. Daniel Stevens, formerly manager of the Victor department of the Cable Piano Co., of this city, has also hitched up to the Vocalion forces, and is ready for the big fall push. In spite of all the handicaps naturally resulting from present conditions, Mr. Byars expects the holiday business of 1918 to eclipse all previous records.

BIG ORDERS FOR MUTUAL PRODUCTS

The Mutual Talking Machine Co., New York, manufacturer of Mutual tone arms and sound boxes, has received large orders from well-known manufacturers in all parts of the country who have tested the Mutual products and who have advised the company that they will use these tone arms and sound boxes exclusively during the coming year. The Mutual factory is working to capacity at the present time to give efficient service to the manufacturers, and judging from the extent of the business on hand it will be necessary to enlarge the factory facilities in order to cope with the demand.



Retailers: Victor Records This Fall Will Be Scarce

We have a fairly good supply of good standard numbers.

Better mail us your order NOW.

Cabinets to match all type Victrolas. Write for quotations.

Write for information about the New Usoskin Window Display Series.

I. DAVEGA, Jr., Inc.

VICTOR FACTORY DISTRIBUTORS

125 West 125th Street

NEW YORK

THE TRADE IN PHILADELPHIA AND LOCALITY

PHILADELPHIA, PA., October 4.—Business conditions in this city are somewhat uneven, and it is safe to say that September was not nearly as good a month with the local dealers and jobbers as the months which preceded it. The jobbers particularly are in anything but a pleasant frame of mind, owing to their inability to supply dealers with all the stock they would like. There is as great a demand as ever for the talking machine. This is noticed on all sides, and if the jobbers and dealers were able to get the goods this would be a phenomenal fall in the way of sales. The letter issued by the Victor Co. has clarified the situation somewhat; it at least informs the trade of certain limitations in output owing to giving a great deal of their plant over to the manufacture of Government work which, of course, must have first consideration. The jobbers and dealers feel that they will receive fair treatment and as large a supply of stock as it is possible for the company to manufacture. At the present time in this city there is a greater shortage of Victor than Edison, Columbia or Sonora machines, but dealers would like to get more of all these makes and could also stand larger supplies of Victor, Columbia and Edison records.

The Penn Phonograph Co.'s New Home

The Penn Phonograph Co. have become fully established at their new home on Arch street. Their entire stock and offices have eventually been moved, and the permanent offices of this firm have been made at the front of the third floor of this new home. Here all the appointments of their former offices, which had been recently established, were brought to the new home and they look very attractive. On this floor, back in their stockroom, a number of improvements, or, I might say, innovations for the handling of records and cases of records have been incorporated. These devices are the result of a careful study of warerooms throughout the country made by members of the firm on a special trip for that purpose made several months before they moved. The fourth floor, which is given over to the record racks also, is an admirable arrangement for convenience. A floor truck system that they have introduced also tends to speed and saves much manual

labor in the distribution of the records. Altogether the Penn Co. have undoubtedly the best equipped place in Philadelphia at the present time. In spite of the shortage of machines and records the firm are well satisfied with the business they did in September. From reports they have received from the Victor factory it looks as though they would receive shipments of about 70 per cent. of last year's supply.

The Penn Co. have undertaken the handling of the Lundstrom cabinet and already have had splendid success with it, having received a large number of orders from their trade, and they anticipate a good delivery from the factory, and they expect to be able to fill all orders now in

hand in a few days. They have also taken on the handling of the Aurora Light.

On account of the great shortage of men the Penn Co. have found it advisable to withdraw all of their men from the road, and now allow them to make just such special trips as is deemed necessary.

A. H. Engle, talking machine dealer at 1710 Fairmount avenue, is adding a number of improvements to his store.

Conditions With the Columbia Co.

A. J. Heath, in charge of the local Columbia establishment, has been away from the office for several days suffering with Spanish influenza, but is much improved. H. E. Gardner, a co-worker with Mr. Heath, is in charge of the business, and he reports that it is away ahead, owing to the fact that they cannot get stock in sufficient quantities to fill their orders. Stock, however, has lately commenced to come through in better shape. They are not looking for new trade, but are bending all their efforts to take care of their regular customers. He said: "The product is so short that we feel that we must give our old Columbia dealers the preference."

George W. Hopkins, general sales manager of the Columbia, was over from New York recently.

Brunswick Line With Theo. Presser Co.

The Brunswick-Balke-Collender Co. report that they had an excellent business in September. They succeeded in placing their line during that month with Theodore Presser, the big Philadelphia music publisher and retailer, and with a number of excellent firms through the eastern section of Pennsylvania. Mr. Nystrom, superintendent of the Chicago Brunswick house, was a Philadelphia visitor recently. It is reported at the offices that they have been very fortunate in getting in several carloads of Brunswick machines recently, which they needed badly to supply their trade.

Machine Shortage Retards Business Volume

The Louis Buehn Co. report that business during the last month has fallen off to some extent, owing to the shortage of goods. The shipments from the Victor factory, both in machines and records, have been small in comparison with last year and previous months, and

(Continued on page 42)

TALKING MACHINE DEALERS

can greatly increase their profits without additional overhead expense, by selling the world-famous

Weymann "KEYSTONE STATE" Musical Instruments

a combination that has proved to be an instantaneous success.

Write for catalogue

H. A. WEYMANN & SON

Manufacturers

Victor
Wholesalers

1108 Chestnut St.
Philadelphia, Pa.

Established 1864

"PENN SERVICE"

Now that we are thoroughly at home in our new quarters at 913 Arch Street, we take the opportunity of again reminding you of "Penn Service."

Penn Service in the past has always meant much. With our new and greatly increased facilities we are enabled to maintain Penn Service at its highest possible state of efficiency.

We are wholesalers only. We have devoted our entire energy in providing Penn Service for dealers.

Penn Phonograph Co., Inc.
913 ARCH STREET PHILADELPHIA



THE WHITE HOUSE
WASHINGTON

Again the Government comes to the people of the country with the request that they lend their money, and lend it upon a more liberal scale than ever before, in order that the great war for the rights of America and the liberation of the world may be prosecuted with ever increasing vigor to a victorious conclusion. And it makes the appeal with the greatest confidence because it knows that every day it is becoming clearer and clearer to thinking men throughout the nation that the winning of the war is an essential investment. The money that is held back now will be of little use or value if the war is not won and the selfish masters of Germany are permitted to dictate what America may and may not do. Men in America, besides, have from the first until now dedicated both their lives and their fortunes to the vindication and maintenance of the great principles and objects for which our Government was set up. They will not fail now to show the world for what their wealth was intended.

Woodrow Wilson

This Space Contributed to Winning the War by

THE LOUIS BUEHN COMPANY

VICTOR VICTROLAS, VICTOR RECORDS AND SUPPLIES

LOUIS BUEHN, PRES. & TREAS.
CHAS. W. MILLER, VICE-PRES.
FRANK B. REINECK, SECY. 835 ARCH STREET PHILADELPHIA





Keep showing the new models. They are so good looking they'll almost sell themselves.

Columbia Graphophone Co.
NEW YORK

THE TRADE AROUND PHILADELPHIA (Continued from page 40)

they look for no change in October. Mr. Buehn has had an interesting letter from Ensign E. P. Bliss, now in foreign waters, but formerly one of his sales force.

Monroe M. Johnson, a talking machine dealer at 2631 West Lehigh avenue, is contemplating the adding of a number of new booths to his establishment in anticipation of a good holiday trade.

Taking on the Weymann Lines

H. A. Weymann & Son, Victor wholesalers and manufacturers and distributors of the "Keystone State" line of musical instruments, report an ever-increasing number of hitherto exclusively talking machine houses taking on their line of musical instruments. Many dealers who did not care to carry a competing line of talking machines have found musical instruments a profitable side line. The Weymann house did a very good business in September, but expect a falling off in October, due to the fact that they are unable to get Victor goods in sufficient quantities to meet demands. Their dealers throughout the country are aware of conditions, and they are showing great patience with the Weymann firm in their attempt to keep them supplied.

Placing Big Orders for Sonoras

Manager Connelly, of the local Sonora Co., has been home for several days ill with the Spanish influenza, although not with a very violent attack. The Sonora Co. had a very excellent business in September and succeeded in placing the machine with a number of dealers who have been unable to get Victors, and have been glad to avail themselves of the admirable Sonora.

Quaker City Edison Dealers Meet

Manager Blake, of Blake & Burkart, reports that while they had a very satisfactory September it was not as large as their August business in volume, but then August was the biggest month that they had so far. At the meeting of the Edison dealers, held at the Bingham House on Tuesday evening of this week, they were addressed by Charles Gardner, of the Edison factory offices. A little banquet was given to the members by the jobbers. There was a very interesting discussion as to the fall plans for the Edison, advertising and promoting, and

THE NEW EDISON USED IN MISSIONARY WORK IN CHINA

The accompanying photograph shows the New Edison in China. This instrument was shipped some time ago to the Rev. Wilbur M. Campbell, Kiung Chow, Hainan, China. The Rev. and

Sunday school teachers' class, which meets every Friday at 4 p. m. in our home. The two little ones are Mary Elizabeth Shannon and my Bible woman's little daughter. Each one of



Sunday School Class at Kiung Chow, China, Which Uses the Edison Phonograph

Mrs. Campbell are American missionaries who have been stationed in China for a number of years and have been very successful in their missionary work. Regarding the photograph Mrs. Campbell writes: "This picture shows our

these people is an efficient worker and they know their Bible! Would you believe it, I put on the 'Pussy Cat Rag' while the picture was being taken in order to get them to smile!" It was evidently very successful.

every one expressed himself as seeing a very encouraging outlook for the Edison for the remainder of the year.

Close Good Month's Business

The Pathé Shop had the biggest month in September that it has thus far enjoyed. As much business was booked as could be handled in view of the amount of goods received. Manager Eckhardt said that a shortage of popular types was felt. He added: "I believe October

is going to beat September." Mr. Eckhardt's oldest son has been drafted into the Students' Training Camp. He is just past eighteen years old, and is a student at Villa Nova College. At present he is "under the weather" with an attack of the grip.

INQUIRY FROM NEW ZEALAND

WASHINGTON, D. C., October 1.—The United States Department of Commerce states that a New Zealand firm has written them that it desires to buy "gramophones, phonographs, accessories and records, also motors, tone arms, sound boxes, needles and sapphire and diamond points." Price quotations may be made f. o. b. steamer at an American port. Payment will be made in cash against shipping documents. The bureau of Foreign and Domestic Commerce, either here or at any of its offices throughout the country, will furnish the name and address of firm if those desiring same will mention, in writing, inquiry number 27461.

All good awaits the man whose desire to serve is the dominant passion of life.

CRYSTAL EDGE MICA DIAPHRAGMS

M
I
C
A

Let us send you samples *today* of our diaphragms and you will readily understand why the best talking machines are equipped with *Crystal Edge Mica* diaphragms exclusively.

We use only the very finest selected mica, the best diaphragm material in the world.

PHONOGRAPH APPLIANCE CO., 109 West Broadway, NEW YORK

LIBERTY LOAN DRIVE HAS CENTER OF STAGE IN BUFFALO

Prominent Talking Machine Men Interested in Putting It "Over the Top"—Some Attractive Window Displays—Starting Holiday Business Campaign—Albert Stettenbenz' New Post—Other News

BUFFALO, N. Y., October 6.—In Buffalo's talking machine trade at this writing the nation's great Fourth Liberty Loan occupies the center of the stage. The talking machine and piano men have co-ordinated their efforts in the drive to exceed their quota of \$215,000. William H. Daniels, of Denton, Cottier & Daniels, Victrola dealers, is chairman of this division and has appointed the following committee of active workers: C. N. Andrews, Benjamin E. Neal, Robert L. Loud, O. M. Kiess, George A. Gould, Jacob Hackenheimer, Albert Stettenbenz, Charles H. Wood, Newton R. Luther and E. P. Erion. Liberty Loan posters of every description are conspicuously displayed in the show windows of the local talking machine stores. The employers and employes are not only buying bonds in a whole-hearted fashion, but are persistently canvassing their customers and personal friends for the same purpose. Chairman Daniels and his committee meet daily at Liberty Loan headquarters, where they are enthused regarding the vital subject of the loan by the best patriotic speakers obtainable.

The holiday sale of talking machines will be much earlier in Buffalo this year than ever before. Early Christmas buying is being advocated by the Buffalo Retail Merchants' Association, of which some of the talking machine men are members. The plan is to spread the holiday shopping over three months—October, November and early December—instead of doing it all in one month. Following the wishes of the Government the merchants will follow these rules during their holiday campaign: "No extra help. No extra hours. No extra deliveries. No 'open evenings.' No extra services of any kind."

A. F. Koenig, head of the A. F. Koenig Piano Co., Pathéphone dealers, is receiving the felicitations of his friends this week on his celebration of the eighth anniversary of his entering business for himself.

The Winegar Piano Corp., which handles the Columbia and Brunswick lines, has built a well-arranged office in the balcony of its store.

Victor & Co., Pathéphone jobbers and retailers, have a striking red, white and blue sign advertising the Fourth Liberty Loan. The sign, which is across the front of the store, bears a well-worded appeal for subscriptions. There is also a Liberty Loan booth at the front of the store. Talented newsboys and theatrical performers give selections in attracting crowds to the booth during the sale of bonds.

Albert Stettenbenz has been appointed treasurer and vice-president of the Utley Piano Co., Inc., which handles the New Edison. Bach Utley, former manager of the phonograph department of this store, is a second lieutenant in aviation at Wichita Falls, Tex., where he is training student officers to make landings.

A Liberty Loan poster, twenty by ninety feet, has been placed in front of the department store of the William Hengerer Co., Victrola dealers. The poster shows a group of Yankees in close-up action, driving the Hun to cover. The Hengerer Co. recently celebrated its eighty-second anniversary.

R. C. Schermerhorn has resigned as manager of Robert L. Loud's piano store to enter the Quartermaster's Department at Washington. E. O. Hock, formerly of the Victrola department of this store, is at Camp Upton. He was a recent visitor here. Lingard Loud, son of the proprietor of the store, will sail for France shortly. He is a lieutenant in U. S. aviation at Lonoke, Ark.

George P. Sawyer, representing the Central Y. M. C. A. of this city, has appealed to Buffalonians to supply talking machines and records to the boys overseas. He says these gifts would bring a lot of sunshine into the strenuous lives of the young warriors in France.

Three large Victrola rooms have been added to the store of Denton, Cottier & Daniels, whose

Victrola manager is C. H. Heineke. His former salesman, Frank Farrar, Jr., is now a member of the new aviation unit at Great Lakes, Ill.

Several of the talking machine jobbers and dealers of western New York attended the National American Music Festival at Lockport.

The warning that talking machines will advance in price and become scarcer is being sounded by most of the local dealers. Increased sales show that customers are heeding the warning.

Buffalo's municipal concerts and community singing, heartily backed by members of the talking machine trade, have been resumed.

PHONOGRAPHS A PAYING ADJUNCT

Two enthusiastic Brunswick phonograph dealers are the James brothers, one of whom is located in Petersburg, Va., and the other, J. S., who conducts one of the leading jewelry and optical stores in Richmond, Va. Both of them have found the talking machine a valuable adjunct to their business.

HANDLING THREE "TALKER" LINES

The Curlin Drug Co., of Waxahachie, Tex., recently took over the Columbia talking machine business conducted heretofore by Harris McIntosh. He will move the Columbia to his Edison and Victor departments at the corner of College and Main streets, thus combining the businesses and also reducing overhead costs.



Paramount Records

A Record for the Independent Dealer and Jobber

- They are 10-inch standard size records
- They play longer
- They have less surface noise
- They have up-to-the-minute popular songs and dance selections made by artists you know
- They are popular priced
- They are backed by effective advertising
- They do not advertise any phonograph

Dealers and Jobbers: Write for full information

MUSIC
ON BOTH
SIDES

NEW YORK
RECORDING
LABORATORIES
Port Washington
Wisconsin

65¢
TO
\$1.25

→ THE DAYTON MOTOR ←

*Runs Silently
Runs Evenly
Does Not Vibrate*

*Gives Lasting Service
Pleases the User
Builds New Business*

These are just a few of the many excellent features that make the **Dayton Motors** so universally popular. Sold all over the world on their merit alone. You, as a manufacturer, know that the life of every talking machine you put out depends upon the Motor installed in that machine. Faulty Motors displease the user and destroy the confidence of the consumer in your product. Therefore you can't afford to use an inferior motor.

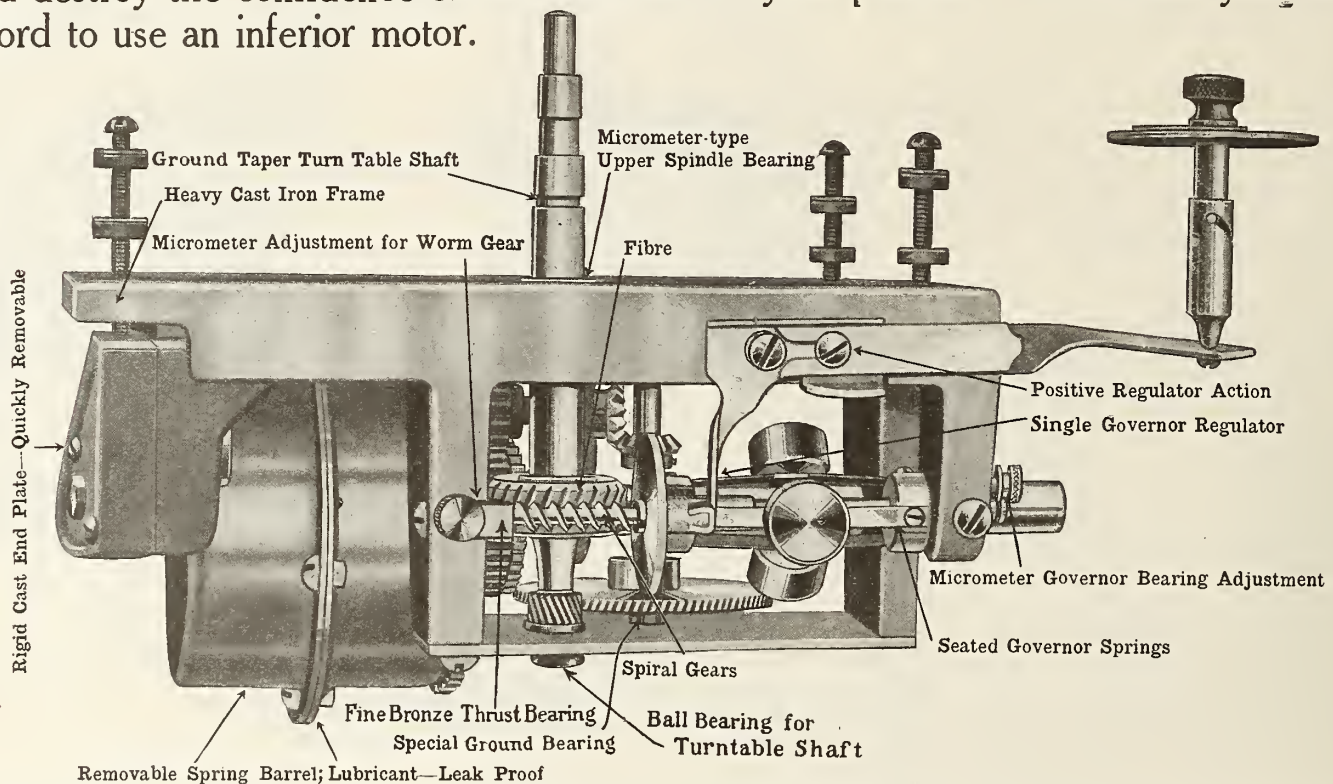

Make your machine a standard of excellence by installing the **Dayton Motor**, which is considered by manufacturers and users as being

The Best Motor in the World

They embody the highest quality of mechanical perfection. Built in "The City of Precision" where National Cash Registers, Delco Starters, Wright Airplanes and hundreds of other products developed wonderfully skilled men. Let us prove it's the best in quality, price and service.

We also manufacture the famous

Dayton Tone Arms, which are universal, playing any disc record. Five styles.

Dayton Reproducers are scientifically correct and thoroughly practical. Two sizes.

Write for full particulars today

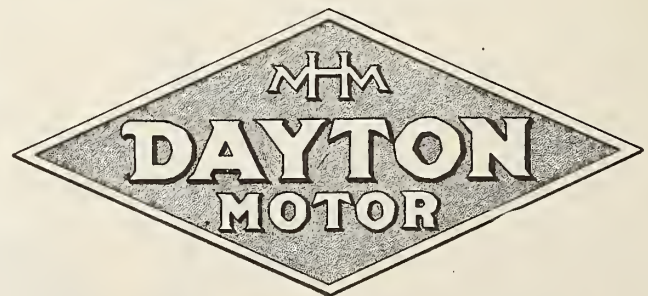

THE THOMAS MANUFACTURING CO.

322 BOLT STREET

::

::

::

DAYTON, OHIO

HOW A LITTLE JAZZ TURNED A FROST INTO A FROLIC

Henry, the Talking Machine Man, Butts Into a Lawn Party With Some Canned Music Under His Wing, and Not Only Livens It Up, But Also Extracts Some Real Coin for Himself Later on

Henry didn't have much to do in his talking machine store. He polished the machines until he had worn through the nickel on the tone arms and the veneer on the cabinets. He dusted off his records until you couldn't see which side the music was on. He cleaned the place so much it started to look worn all over, and still there was time to kill between customers. Not between customers exactly, but between the people who came in and asked him to do impossible favors like getting them certain popular records or popular types of machines.

Henry always figured out he could not keep a clerk. "It is a one-man business and you've got to know it. Put a boy in here and it will be like putting a monkey wrench into the machinery." Thus he pondered. Suddenly he glanced at his shoes, and got a happy thought. He wouldn't have to wear brogans if he wasn't going anywhere. He chirped to himself, "For all the walking I do outside the store I might as well go barefooted and save about five bucks a month. Guess I will go and use the old Douglasses a bit." Then came the question of where to go. Henry takes the "Morning Bugle" off the desk, gives the society column the O. O. and discovers that Mrs. Jones-Smith-Brown is pulling off a swell lawn fete for the Red Cross the same p. m. "Guess I'll shut up the joint and look the frails over." When he gets to the lawn party all is stillness. The dames are from thirty-five up, and are making believe they are enjoying themselves in their sweet girlish ways. But not a note of music. There is a classy dancer on the mat. Without music her actions make it appear that she is going nuts. "It's a tough world," muses Henry. "Guess I'll cheer them up a bit." And back to the shop he plods. Putting a small machine and a half dozen dance records for serious thinkers under his wing he blows back to the lawn party

and crashes in. The boss of the works meets him at the gate, perches her periscope before her eyes and chirps: "Pawdon! The tradesmen's entrance is in the rear." "Tradesmen's entrance nothing," says Henry. "I'm no tradesman, that's why I shut up the joint. I'm just a little angel of joy dressed up like a man." "I don't comprehend," says the lady of the house. "Comprehend what?" says Henry, "Me or the dance?" "Both," says the lady and laughs. "Well," remarks Henry, "I blew by a while ago to give your lawn party the O. O., and on the level from the amount of enjoyment most of the gang were having, it might as well have been exercise time at the Home for the Aged and Infirm. Was the lady who was spreading herself over the lawn, with bare legs, and very little clothes, suffering much?" "She was dancing," quoted the lady with a haughty stare. "Dancing me eye," says Henry, "Can't be done without music. That's why I came back with this stuff under my arm." "What is it?" says the lady, while deciding whether to call a cop or the dog. "Just a talking machine," says Henry. "Cawn't bear them," says the lady. "Well, I've borne this one for a good half mile under my arm," says Henry, "and I would like to let it rest awhile. Can't I sit down for a minute before I start back?" "We don't care for intruders," snapped the boss of the works, "but I suppose I'll have to let you rest a bit."

That's all there was to it. Henry started a dance record that actually made the Grecian impostor wiggle out of her veil. He put on a little jazz, aroused the young ones out of their trance, and put them into action. He started one of the good old tunes, and the crowd gathered around to relieve themselves of stray notes. The party got so lively that the girls in the booths started to do business and take in some money. From a plain intruder Henry grew into

a center of attraction, and so they would all know who he was he distributed a few cards.

A day or two afterward a couple of the Janes came in to get some of the records he had played. They were the kind that he had on hand and wanted to sell, and he made up his mind right then to put a girl in the shop and extend his social sphere. Taking in parties three or four times a week with tea and cake is rough exercise, but business is business. In a month or so ladies giving parties for charity or to sell War Savings Stamps called up Henry and asked him to come and bring his machine, and, of course, his kindness just simply could not go unrewarded. Besides those who bought because they fell for the melodies, there were almost as many who bought just to be polite, but they bought and they paid cash, and the girl in the store managed to make her salary and a few dollars more. John Henry read the war news and saw that his business was going to get back to normal in a few months, and then he went out and bought a new pair of shoes.

FIRST SOUVENIR FOR NEW YEAR

The Otto Heineman Phonograph Supply Co. has just sent out to its patrons a handsome "Humanity Flag" calendar for 1919, which is the first souvenir for the new year that has been announced by a member of the phonograph industry. This calendar has particular significance at the present time, as it features a composite flag that is destined to be one of the most popular souvenirs of the present war. The "Humanity Flag," as it has been termed by the originator, consists of "Old Glory," the "British Jack" and the Tri-Color of France. It is remarkably artistic in its conception and design and has been endorsed by Ambassador Jusserand and other prominent men in public life. The calendar featuring this flag will undoubtedly be appreciated by the Heineman clientele.

If you want the Kaiser to send you an Iron Cross, don't buy any Liberty Bonds.

SOMETHING NEW

THE FLETCHER REPRODUCER

EXACT SIZE



After years of practical experience and experimenting, we are pleased to offer a Reproducer constructed on entirely new principles. In its natural reproduction of tone, either vocal or instrumental, it astonishes and pleases beyond expression, and a Caruso, Galli Curci or Heifetz sounds as if the artists themselves were before you.

The Fletcher Reproducer is different from the ordinary sound box, not only in construction, but in results. You hear no metallic noises, but an accurate reproduction of the human voice or musical instrument as it is recorded. If used with a fibre needle it will give practically as much volume as with a steel needle and save the wear on the record. The Fletcher Reproducer brings out detail on the record that cannot be heard with the ordinary sound box.

The Fletcher Reproducer is different. Hear it and be convinced. A sample order carries with it a guarantee of satisfaction or money refunded. Samples to dealers and manufacturers \$4.00.

We are filling all orders, within the limits properly imposed upon the industry by the Government. Write for prices and terms.

FLETCHER-WICKES CO. 6 E. LAKE STREET
CHICAGO - ILL.



Pathé



The Quality Phonograph



An
Enlargement
of the
**Pathé
Sapphire
Ball**
and Pathé
Record Grooves

No Needles to Change

The Pathé Sapphire Ball takes the place of needles. It need not be changed.

Long Life to Records

(Pathé Guarantee)

We guarantee every Pathé Record to play at least *one thousand times* with the Pathé Sapphire Ball, without impairment to the unexcelled beauty of tone and without showing any perceptible wear on the record.

The Pathé Controla

With the Pathé Controla you may increase or decrease the tonal volume of the Pathé Phonograph at will.

Plays All Records

Each Pathé Phonograph plays not only Pathé Records, but all other makes of records, and plays them perfectly.

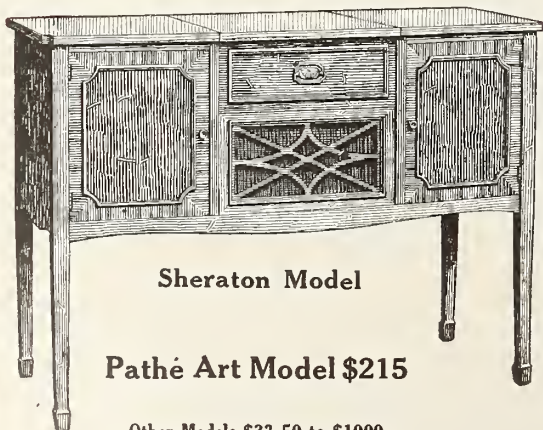

Sheraton Model

Pathé Art Model \$215

Other Models \$32.50 to \$1000

Conserve!

BECAUSE the country needs the great quantities of high quality steel and the great number of skilled men used in making all the needles. Because needles are growing higher in price and scarcer every minute.

Help conserve this precious war metal. Sell the Phonograph that takes no needles.

Ever since its origin, the Pathé Sapphire Ball has been the best phonograph selling point for the dealer. It is *exclusive*, permanent—does away with needles altogether—produces pure natural tone and gives long life to records.

Better than ever today!

Do you know what "The Other 20%" is? Write for book, "The Other 20%," and it will tell you plainly and *convincingly*.

Pathé Frères Phonograph Company

20 Grand Avenue

Brooklyn, New York

The Pathé Frères Phonograph Co. of Canada, Ltd., Toronto





Pathé



Records

—and Save!

THINK what it means to you in the making of sales, when you can say to your customers:

“Save — Records — Money. Buy Records that won't wear out.”



MURATORE—Exclusive Pathé Artist

Here's the Pathé Guarantee:

“We guarantee every Pathé Record to play at least one thousand times with the Pathé Sapphire Ball without impairing the unexcelled beauty of tone, and without showing any perceptible wear on the record.”

In the recent suit of the American Graphophone Company (Columbia Graphophone Company) against the Emerson Phonograph Company, Inc., an interesting piece of testimony was given by Prof. Frank L. O. Wadsworth, appearing as an expert for the Columbia Company, as follows:

“Pathé records were the best samples of recording and music on the market and in his opinion excelled anything else in quality, and that he could not testify conscientiously otherwise, although he did not expect in any way to profit by this testimony.”

But learn for yourself. Send for “Pathé Special Demonstration Record”—a record worth \$1.25 but selling for 35c. to demonstrate the superiority of Pathé Records. And 35c. attachment that enables Pathé Records to be played on other machines.

Pathé Frères Phonograph Company

20 Grand Avenue

Brooklyn, New York

The Pathé Frères Phonograph Co. of Canada, Ltd., Toronto



PITTSBURGH CONCERNED OVER MACHINE SUPPLY

Campaign to Place Christmas Orders Early—
Dealers' Association Elects Officers—Standard
Co.'s Stock List—Edison Tone Tests—Pathé
News—New Brunswick Agents

PITTSBURGH, PA., October 5.—The outstanding feature of the talking machine market in the Pittsburgh district is the fact that practically all of the dealers are vitally concerned over the immediate prospects for keeping an adequate supply of machines and records on hand. In Pittsburgh, as in other centers where the talking machine trade is one of the leading commercial interests of the community, it is plainly seen by visits to the various shops that sales while brisk are more or less hampered by the fact that no assurance is to be had that there will be an ample supply of machines for the usual fall and the much greater holiday trade.

Considerable stress is being placed by a number of the progressive dealers in directing the attention of their customers who are planning to give records and talking machines as Christmas gifts to place their orders early.

Manager F. G. Passoth, of the talking machine department of the Rosenbaum Co., said: "Talking machines for Christmas should be bought now, when our stocks are complete, as we can offer no assurance for last-minute deliveries." Mr. Passoth was the recipient of numerous congratulations from his fellow dealers upon the formal announcement that "the world-famous Victrolas and Victor records are now sold at the Rosenbaum store." The company for years has been selling the Columbia line, and a few weeks ago purchased the stock and good will of the Pittsburgh Talking Machine Shop on Oliver avenue. This will give them the Victor and Columbia lines.

The annual election of officers of the Pittsburgh Talking Machine Dealers' Association, which was held at the annual meeting at the Hotel Chatham, resulted in the choice of the following: President, C. L. Hamilton, of the S. Hamilton Co.; vice-president, H. H. Meyers,

MICA

BEAUTIFUL FINISH
DIAPHRAGMS OF BEAUTY
THE INTERNATIONAL MICA COMPANY

Factory, 37th and Brandywine Streets Office and Sales Department, 1228 Filbert Street
PHILADELPHIA

Sharpsburg; treasurer, Jacob Schoenberger, of Lechner & Schoenberger, and A. R. Meyer, secretary. Mr. Meyer, who is manager of the Victrola department of the Joseph Horne Co., was unanimously re-elected on the assumption that "one good term deserves another."

The Pittsburgh Talking Machine Dealers' Association is a live body of up-to-date dealers. They hold meetings monthly, at which matters that are of vital interest to the trade as a whole are discussed. Visiting representatives of the leading talking machine concerns are often guests at their monthly dinners, which precede the business sessions, and practical talks are given on various phases of the business. Frequent social meetings are held also, at which the gentle sex are guests of honor.

The Standard Talking Machine Co., Victor distributors, are sending to their dealers the "Standards in Stock List" of Victor records and calling attention to the fact that "a tremendous record demand is coming." It is also pointed out in the circular that "All talking machine authorities are agreed that this fall will undoubtedly see the biggest call for records in talking machine history. To meet this demand dealers will have to depend very largely on distributors' present stocks, and your profits will be governed in a large degree by the promptness and wisdom of your orders on such 'in stock' lists as this. This list represents only those numbers in our stock in which we are fortunately well stocked."

Sergeant L. C. Mountcastle, a former member of the road force of the Standard Co., who is now in the Signal Corps "somewhere in France," sent to the company a large helmet which he obtained on the battlefield, and which was owned by a German soldier. The helmet is on view in the showrooms of the Standard Co., with a card explaining how it landed in Pittsburgh.

H. J. Brennan, of the Pittsburgh Pathé Shop, and who also has charge of the wholesale department of the Pathé Frères Phonograph Co.'s local interests, anticipates a brisk trade for the fall and early winter. He stated that he had made ample provision for caring for the demands of the trade both in the retail and wholesale departments, but found that the sales were continuing at so brisk a rate that there was a possibility of a slight shortage in certain lines. He was of the opinion that the wise buyer would be in the market early for his needs.

J. A. Endres, manager of the local Brunswick-Balke-Collender Co.'s Brunswick phonograph agency, returned from an extended business trip through his territory, visiting dealers in eastern Ohio, West Virginia and western and northwestern Pennsylvania. He said: "I found all the Brunswick dealers well satisfied with the outlook for the fall trade and pleased at the manner in which our company has been shipping the Brunswick machines. There is every indication that the October business will far exceed that of September, which was quite large and a marked increase over September, 1917."

The Cheney phonograph is finding a ready sale in this city, and this is largely due to the fact that the agency is in the hands of the Dauler & Close Furniture Co., a concern of standing and one that has been established several decades. The company have a splendid Cheney demonstration room on the seventh floor of their building.

The Buehn Phonograph Co., Edison distributors, find ever-increasing demand for the Edison phonograph and Edison records. The series of tone tests that were held recently in Western Pennsylvania and Ohio towns proved to be a drawing card and delighted hundreds who marveled at the remarkable tone tests. The principals in the tests were Amy Ellerman, the well-known contralto soloist, and Irma Seydel, the brilliant violiniste, with Prof. Calvin Coxé as director.

The tests for the week starting September 30 were held as follows: Monday, September 30, Monongahela, Pa., Charles Nessler, dealer; October 1, test held; October 2, Butler, W. W. Steadman, dealer; October 3, New Castle, Pa., W. W. Dufford & Co.; September 4, Salem, Ohio, W. G. Fawcett & Co. The artists acquitted themselves in a creditable manner and the tests with the Edison phonograph and records were very satisfactory. The tests were held under the auspices of the Buehn Co., and attracted crowds of people.

H. C. Niles, manager and secretary-treasurer of the Starr Phonograph Co., of Pennsylvania, reports a brisk demand for Starr phonographs and Gennett records.

Miss Mae Hartnetta has joined the sales force of the Pathé Shop. Miss Ruth Dawson is the new office manager of the Starr Phonograph Co. of Pennsylvania. Miss T. Green, who for some years was connected with the Buehn Phonograph Co. in their retail department, has resigned and has entered the employ of the Pennsylvania Railroad.

Mrs. C. C. Mullen, secretary-treasurer of the Henricks Piano Co., presented the student soldiers at Schenley Barracks, Pittsburgh, with a \$150 talking machine. Her attention was directed to the starting of a fund for the purpose in the Pittsburgh Dispatch, and having just returned from a visit to her nephew, who is in camp at Cape May, she notified the Dispatch of her intention. The money that had been sent in to the newspaper for the fund will be used in buying records. While at the Cape May camp Mrs. Mullen stated that she was given ample demonstration of the need of music for the soldier boys, hence her gift.

Why Brown Quit Buying Phonograph Records

When Brown first bought his phonograph, all records sounded good to him and he bought everything.

He Was Not Musically Educated Then

In a short time Brown became more careful in his selections, and bought a better class of records.

His Education, Musically, Had Commenced

Soon Brown reached that point where he rarely played his phonograph, and ceased buying records.

Brown Was Now Musically Ahead of His Phonograph

Hearing of the BLISS REPRODUCER, with its treated silk diaphragm, Brown skeptically bought one.

Brown Now Buys New Records Weekly

There are over a million silent phonographs in the United States to-day like Brown's, but the Bliss Reproducer, if properly presented, will revive them and increase your record sales.

The Bliss Reproducer IS Different From Any Other

Other Phonograph Specialties that we are featuring are the "Disk-Lite," an electric lighting attachment adaptable to any phonograph, and the "Phono-Lite," an automatic lighting attachment for the New Edison, also Edison Diamond Points, Edison and Pathé Sapphire Points, Lakeside Rotometers, Johnson Electric Motors, B. & H. Fibre Needles, B. & H. Fibre Needle Repointers, and the Vallorbes Semi-Permanent Needles.

Write for our dealers' price list,—or
may our Parcel Post Salesman call?

WILSON-LAIRD PHONOGRAPH CO., Inc.
29 West 34th Street NEW YORK CITY



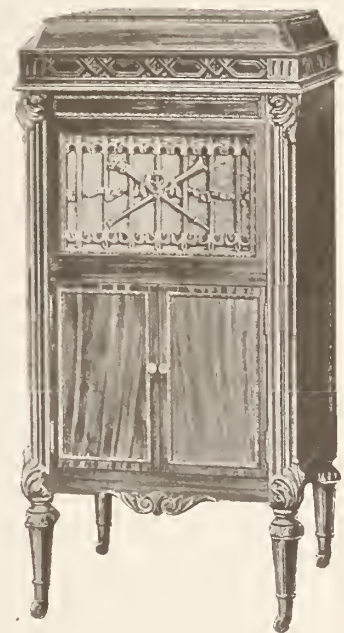
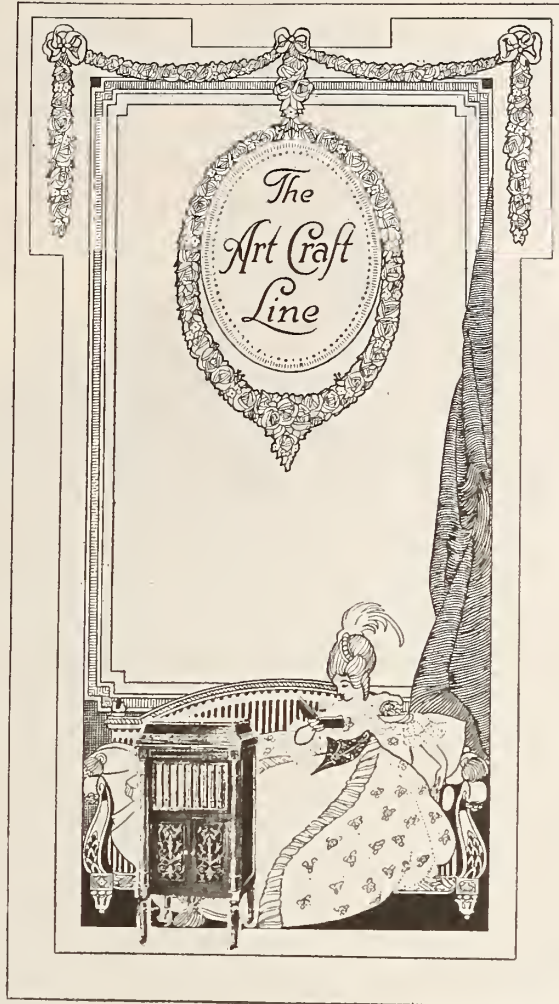

The Art Craft Line of Talking Instruments

- Superior in Design
- Superior in Quality
- Superior in Workmanship
- Superior in Tone
- Superior in Equipment
- Superior in Operator's Conveniences
- Superior Proposition

The above is a lot to say, but we are privileged to make these statements as they are facts and backed up by the Art Craft Line.

We invite comparison and correspondence which will enable us to give you detailed information that will convince the most skeptical.

Six
Art Models

\$115.00
to
\$350.00

The Art Craft Company

MANUFACTURERS OF

The Art Craft Line

PHONOGRAPHS

GRAND RAPIDS, MICHIGAN

The
Instrument
of
1928

OUTING OF J. E. DEAN EMPLOYES

Annual Event at Rocky Point Thoroughly Enjoyed by Every Member of the Party

PUTNAM, CONN., October 4.—The employes of the John E. Dean factories in this city, which



Group of Picnickers at Outing of J. E. Dean Employes

constitute a division of the Otto Heineman Phonograph Supply Co., New York, recently held their annual outing, and this event was



Ready for the Start of Race

thoroughly enjoyed by every member of the party.

Rocky Point, just below Providence, R. I., was

the pleasure resort chosen for this outing, and the employes of the Dean factories, together with their friends, were conveyed by automobile buses to this point. The trip was a pleasant one, as several members of the party had musical instruments that they considered were absolutely essential to the success of the outing.

MARIE MORRISEY STARTS TOUR

Edison Artist Giving Tone Tests in Various Parts of the Country

Marie Morrisey, the popular concert contralto and well-known Edison artist, is now being booked in a trans-continental recital tour to commence in February, 1919. Her appearance will be in joint recitals with Theodore Spiering, the well-known violinist.

Miss Morrisey has had a number of requests for concert dates during the fall, which she has



Miss Marie Morrisey

had to decline, owing to the extensive tour which she will make for Thomas A. Edison, Inc., giving tone test recitals with the New Edison phonograph.

The Edison tour started in Canada on September 23, ten concerts being given in and around Winnipeg, Man. After two weeks in Canada she will spend two weeks in New England, followed by five weeks in upper New York State and one week in the vicinity of Philadelphia. The entire tour will consume ten weeks, during which time about fifty-five concerts will be given.

On the Edison tour Miss Morrisey will be assisted by Joel Belov, assistant concert master of the Philadelphia Orchestra. Mr. Belov is an Edison artist also, having recorded recently five very interesting Re-Creations which are destined to win favorable notice.

Trouble is destined to human life. It is a noble thing to interpret it and to discover its relation to the best things of life and of hope.

At 10:30 in the morning a series of games was started with several prizes as the rewards for the leading contestants. A tug-of-war, a forty-yard dash, an obstacle race and a swimming race all contributed to the success of the sports program, and, needless to say, when luncheon was ready to be served the members of the party did ample justice to the shore dinner.

The first prize, a \$115 phonograph and twenty-five "OkeH" records, was won by C. La Mondy, and the second prize, consisting of a \$60 phonograph and twenty-five "OkeH" records, was won by A. Morin. Mr. La Mondy proved himself an efficient and all-around athlete, and his splendid showing in all of the events well justified his winning of the first prize.

ENTHUSIASM A BIG FACTOR

In Successful Salesmanship—It Implies Faith in Itself and the Goods Handled

A man who had been selling one very well known article of American manufacture in Europe with marked success for over four years was asked once before a large audience to explain how he sold his goods. Quick as a flash, and short and sweet came his speech: "Only this, I can answer any questions that anyone in all Europe can ask about the article I'm selling."

He knew his business and he knew his goods—two essentials to success.

It will pay to know human nature. Study your customer. Learn his likes and dislikes. Respect his opinions, even though you may not agree with him. Sell him what he wants; but if you know he is buying something beyond his means be man enough and honest enough to tell him frankly not to buy it.

Mark this: "A satisfied customer is worth

more than a bargain"; and this, "A satisfied customer is the best argument you can offer to secure another."—Wallace Pond.

A TRIBUTE OF WHICH TO BE PROUD

As fine a tribute as ever was paid to a concern in any industry by a competitor was paid just lately to the Otto Heineman Phonograph Supply Co. by the president of another company manufacturing a phonograph accessory.

"In my dealings with the Heineman concern," said this executive, "I have never had occasion to rebuke it for any unkept promises. The material it sold me was just as represented, in an excellent and pliable condition. From Otto Heineman himself down to the least important employe of the firm every man is a gentleman and many have often gone out of their way to emphasize the Heineman policy of satisfaction, absolute and unconditional. Together with this ethical way of doing business, the Heineman prestige is further reinforced by the innate excellence of its many products."

The Duo-Tone

EQUIPPED WITH TUNGSTEN NEEDLES

Soft or Loud

without

changing

Thousands of talking machine owners are using the Duo-Tone and De Luxe Needles.

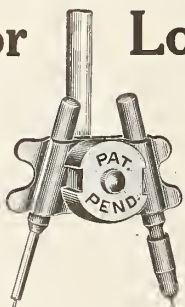

The De Luxe Stylus

SEMI-PERMANENT

Plays 100 to 300 Records

No Scratch or Hiss

Perfect Points

Mr. Dealer: Are you interested in increasing your profits and satisfying your customers? Would you invest \$11.75 to make a quick profit of \$7.45? If so, order at once our attractive Counter Display Stand or Silent Salesman, containing 12 Duo-Tones and 24 packages De Luxe Needles.

Descriptive circulars furnished. De Luxe stylus furnished separately. Write for samples and discounts.

The Duo-Tone Company, Ansonia, Conn.



Otto Heineman Phonograph Supply Co.

INCORPORATED

25 WEST 45th STREET, NEW YORK

FACTORIES, ELYRIA, O.—NEWARK, N. J.—PUTNAM, CONN.

CHICAGO

ATLANTA

SEATTLE

CINCINNATI

TORONTO



OKEH RECORDS

Music on both sides.
Sapphire or steel needle.
Popular and standard selections.

Full particulars regarding the distribution of this record will be given to any dealer or jobber upon application.

THE QUALITY RECORD

Superior in tone
Distinct and clear
Music perfectly reproduced
Unmarred by mechanical noises or "scratching"



GREAT ARTISTS

Patriotic Music, Popular Songs, Dance Hits, Musical Comedy, Grand Opera, Standard and Sacred Gems

NOW READY

NOW READY

The President's approval reads:

"OKEH—WOODROW WILSON"

If you wonder why OKEH, instead of OK, look in your dictionary.

OK—A humorous or ignorant spelling of what should be *okeh*, (Choctaw Indian), OKEH an "article pronoun", a kind of adjunct, meaning "it is so"; a use that may be compared with that of the Hebrew and European "amen", all right; correct.

You may spell your approval either way, but you will certainly put your sign of approval on the latest product of the House of Heineman.

O K E H



R E C O R D S

The Record of Quality

JOBBER
DEALERS

OKEH RECORDS are of special interest to you.

A remarkable proposition.

Get in touch with us today.

Have you heard an OKEH Record?

OTTO HEINEMAN PHONOGRAPH SUPPLY CO., Inc.
25 West 45th Street, New York.
Gentlemen:-

I am interested in your OKEH RECORDS
Please put me on your mailing list.

Name.....
DEALER OR JOBBER

Street.....

City..... State.....

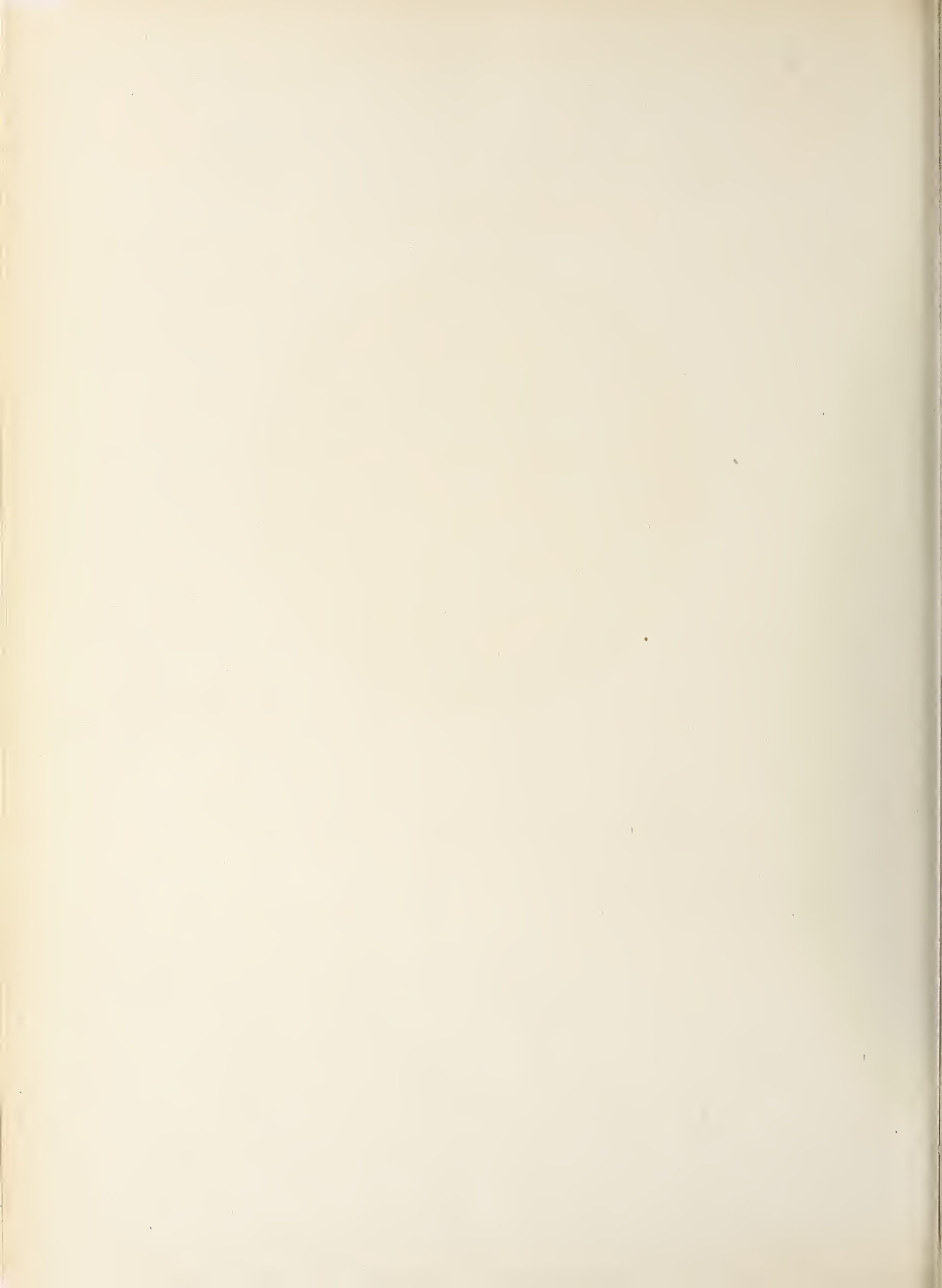

B. P. WOODWARD TO OKLAHOMA CITY FAMOUS & BARR SECURE AGENCY FOR AEOLIAN-VOCALION

Kansas City Man Will Be Manager of the Phonograph Shop, Inc., in That City

B. P. Woodward has severed his connection with the Phonograph Co., of Kansas City, with which he has been associated for some time as manager of the retail Edison Shop. Mr. Woodward's experience in the Edison business has covered a period of about ten years, and during this time he has gained the real inside knowledge of the talking machine game in its various phases. Hereafter, Mr. Woodward will be associated with A. H. Smith, a man well known in the Edison field, as manager of the Phonograph Shop, Inc., at Oklahoma City, Okla. A number of branches come under the supervision of the Oklahoma City store, including Tulsa, Ardmore, Muskogee, Okmulgee and Ada. The shop handles the Ediphone, the Edison dictating machine, in addition to the Edison phonograph. In this move Mr. Woodward is consummating plans of comparatively long standing.

TIMELY PATHE FRERES PUBLICITY

The advertising department of the Pathé Frères Phonograph Co. has prepared for the use of Pathé dealers timely literature featuring new popular hits that have been recorded for the Pathé library. These popular hits have met with a ready sale throughout the country, and this literature enables the dealer to feature them to excellent advantage.

One of the best-selling Pathé records at the present time is the selection "Oh, How I Hate to Get Up in the Morning," which achieved such remarkable success in the soldiers' play, "Yip, Yip, Yaphank." Another popular number is "Smiles," and "Everything Is Peaches Down in Georgia" is also being welcomed heartily by Pathé dealers. It may be added also that the standard selections in the Pathé list are also in demand.

Prominent St. Louis Department Store Installs Complete Aeolian-Vocalion Line in Music Department—Will Be Handled in Addition to the Victor Line—Good Stock on Hand

St. Louis, Mo., October 4.—The most notable talking machine event of the month was the installation of the Aeolian-Vocalion line in the musical department of the Famous & Barr Dry Goods Co. This was the last of the big downtown talking machine departments to deviate from the idea of handling one line exclusively, and at the present time the Victor and Aeolian-Vocalion lines will be featured in this department.

Referring to this important announcement John F. Ditzell, manager of this department, commented as follows: "As early as last July I saw that there was coming a time when the Victor Co. would not be able to supply enough of our goods to enable us to sell that line alone. So I began investigating the various machines offered, as I wanted something that had the proper musical atmosphere for our department. After making extended investigations and thorough tests along every conceivable line I finally selected the Aeolian-Vocalion as the instrument that came nearest to our ideals. It is a pleasure to look at and in them, and the music-lover who appreciates musical instruments will undoubtedly welcome these machines. We are going to present them as our first choice after the Victor."

The fact that the Aeolian Co. was going to put the Aeolian-Vocalion line for sale elsewhere than at Aeolian Hall was not generally known, and the Famous & Barr announcement was something of a surprise. Mr. Ditzell says that he is assured of a constant supply of Aeolian-Vocalion phonographs, and that he has had an ample stock to take care of anticipated needs for the immediate future transferred to his own warehouse.

Recent sales totals have passed expectations, according to Mr. Ditzell, considering the

stocks which were available. Record business especially has been good. In all lines the demand has been for higher-priced products.

"We have more prospects than we have been able to follow up," said Mr. Ditzell, "and we find that the people have money and are willing to buy. Sales are easily closed and payments are large. The only trouble experienced nowadays is that the prospect often gets a bit dazed when it comes to closing a contract. The chief idea appears to be 'Here we are buying this handsome Victrola that we have wanted for years. It cannot really be true. It seems that the good fortune is a bit too good to be true.' But, of course, such objections are more easily overcome than the old trouble of having to talk them up to making the proper payments from too slender an income."

PRaise FOR THE CORTINA METHOD

The Cortina Academy, of New York, is receiving an increasing number of letters praising its method of teaching languages with the aid of the talking machine. It is the practice to reproduce these letters faithfully where permission is granted, which provides a valuable sales help not only for them but for the dealers who carry the line as well. Among those recently received is one from Paul R. Radosavljevich, Professor of Experimental Pedagogy, in the New York University; J. E. Kennedy, of the Wisconsin Mining School, and one from the Newport branch of the Army and Navy Young Men's Christian Association. All three advise the Cortina Academy that they have found the course helpful in their various lines of endeavor. The first two have used the regular Cortina language course, and the last-named the French-English military course.

The Leonard Markels BUTTERFLY MOTOR

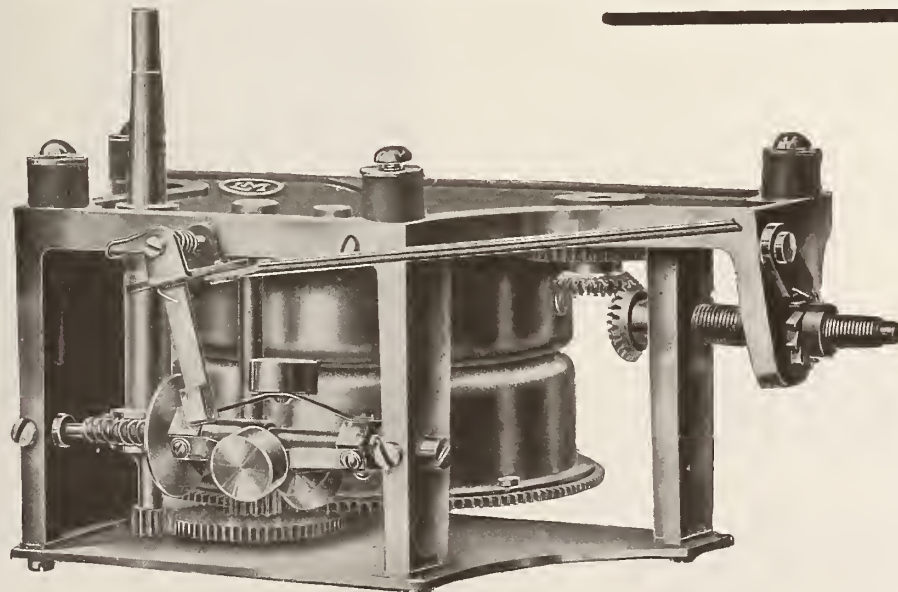

The Leonard Markels Jewel Bearing Butterfly Motor

has revolutionized the motor industry. It is silent running and silent winding and represents the acme of perfection in motor construction.

This motor has achieved phenomenal success, and is being used exclusively by leading phonograph manufacturers in all parts of this country and Canada.

Write today for a copy of our **New Butterfly folder**

- Specifications*
- Beveled gear noiseless winding,
 - New ratchet device that prevents clicking.
 - Bakelite intermediate gear—absolutely silent.
 - Plays seven 10-inch or five 12-inch records at one winding.
 - Cast iron nickered frame.
 - Powerful, durable, compact, accessible.
 - Built especially for the highest-grade machines.
 - Guaranteed in every minutest detail.

LEONARD MARKELS - 165 William St., New York



No. 250

THE phonograph of the future will be bought for Tonal Quality and aesthetic qualifications, not because of mechanical details which have in the past been widely advertised.

After all, mechanics are only by-play, although important now, and may be swept aside any day by new inventions. What remains is Beauty and Tone, the Prime Cause for the existence of the

STRADIVARA

Art Phonograph

PATENTED

“KNOWN FOR TONE”

Manufactured by

The COMPTON-PRICE COMPANY

COSHOCTON, OHIO

SEVEN MODELS TO RETAIL FROM \$60 TO \$250, WITH UNUSUAL TONE QUALITY AND EXQUISITE WORKMANSHIP. FULL ADVERTISING SERVICE, OF COURSE :: :: ::



No. 200



No. 175

KANSAS CITY TRADE BOOSTING FOURTH LIBERTY LOAN

Talking Machine Dealers Concentrate Their Energies on Work of Putting Fourth Loan Over the Top—Business Continues Excellent, With the Demand Exceeding the Supply

KANSAS CITY, Mo., October 6.—When Kansas City goes over the top by a big margin in the Fourth Liberty Loan, which started last week, it will be largely due to the concentrated efforts of the talking machine men in this territory. During the preceding drives they have never failed to respond to the call for service. Talking machine men have closed their desks and left their departments to care for themselves while they have devoted all their pep and enthusiasm to the more serious business of winning the war.

A. A. Trostler, manager of the Victrola department of the Schmelzer Arms Co., is captain of a division which has charge of the nine square blocks between Twelfth and Fifteenth streets and Walnut and Oak streets. Among his lieutenants are E. A. McMurtry, manager of the Columbia Grafonola wholesale; M. M. Blackman, manager of the Edison wholesale, and Harry Wunderlich, president of the Wunderlich Piano Co. It is the business of this team to raise \$500,000, and, according to Mr. Trostler, it is not a question of whether they can, but of how far they can go over the top. "Talking machine business has been very good," said Mr. Trostler, "considering that we have very little to sell. However, we have all reconciled ourselves to the fact that the business of the day is winning the war. When the war is won we can get all the goods we need."

B. J. Pierce, manager of the Victrola department of the J. W. Jenkins' Sons Music Co., is chairman of the four-minute singers in the Fourth Liberty Loan drive. He is devoting his entire time to booking soloists, duets, quartets and choruses, including the choruses from the four Kansas City high schools, for about sixty theatres in the city. In the moving picture theatres the national airs are thrown on the screen and the four-minute singers lead the audience in community singing.

R. S. Pier, assistant manager of the Columbia Co., wholesale, is leaving to go into the Naval Reserve Training School at Chicago. Mr. Pier will be succeeded by E. R. Smith, formerly manager of the St. Joseph branch of the National Biscuit Co.

Clayton Cunningham formerly Kansas traveler for Edison out of Kansas City, has resigned his position to take over the management of the Edison department of the Zinn Optical and Jewelry Co., Hutchinson, Kan.

M. M. Blackman, manager of the Edison wholesale, has just returned from a brief business trip to Chicago.

R. F. Bolton, manager of the international record department of the Columbia general offices in New York, was a visitor to the Kansas City branch.

Glen Ellison, Scotch baritone, has completed a five weeks' tour of the Edison dealers in this territory and has left for Detroit, Mich.

O. D. Standke, manager of the Victrola department of the Geo. B. Peck Dry Goods Co., reports unusually good business for the month of September, with a substantial increase over the same month a year ago. "We are selling a large number of machines on a cash basis," said Mr. Standke, "and collections and terms seem to be excellent."

Miss Olga Gates, formerly connected with the J. W. Jenkins' Sons Music Co., is now a record saleswoman at the Victrola department of the Geo. B. Peck Co.

D. M. Guthrie, manager of the Columbia Shop, is making preparations to enter the service very shortly. At present it is planned to leave Mr. Guthrie's position unfilled, Miss Miller having charge of the sales, and Mr. Polk having charge of the credit departments. Mr. Guthrie reports that business has been very good and the record business beyond all expectations.

Miss Connely, saleswoman for the Columbia Grafonola Shop, is leaving for Washington, D.

C., shortly. Her position will be filled by Miss Marshall, formerly connected with the J. W. Jenkins' Sons Music Co.

The Henley-Waite Music Co. reports a wonderful business in talking machines, with excellent results from the daily public recitals, which the company has been holding. Henley-Waite's now carry a complete line of Grafonolas and also handle the Artophone.

Miss Frances Hinson is now connected with the phonograph department of the Henley-Waite Music Co.

W. C. Chestnut, retail manager of the Brunswick Shop, leaves October 5 with the Seventh Regiment for two weeks' sojourn in camp at Nevada, Mo.

Ralph Wortman, of the Pioneer Music Co., Emporia, Kan., and J. E. Lindemood, of Paola, Kan., are new Brunswick dealers.

Recent visitors to Kansas City were Lester

Birchfield, manager of Sanger Brothers, Dallas, Tex.; C. L. Dosch, music dealer of Maysville, Mo.; Willard Pierce, son of J. Pierce, manager of the Victrola department of the J. W. Jenkins' Sons Music Co., who is a member of the Students' Army Training Corps; Frank Haight, president of the Pioneer Hardware & Music Co., Burlington, Kan.

CONSTRUCTING ADVERTISING 'COPY'

There is an art in constructing good advertising "copy," that is worth study.

Don't wander in your advertising arguments. Make one point follow logically after another. In this way the average man will read to the end, and the farther he goes, the greater becomes his desire to purchase, if he is at all interested in the article. Your copy will then be constructed like a well-built house. It takes thought and effort, but it brings results.

Work becomes a source of real gratification when the interest of the worker is centered on it.

How Much Would the KAISER Tax Your Business?

Think this thought twice over: "If we should fail to win this war, what would happen to my business?"

What is left of business in the invaded districts of France and Belgium? What will be left of business here, if we fail to crush the sinister power of Prussian militarism? How much would you have left after paying the taxes and levies imposed by a victorious Germany?

Defend Yourself With LIBERTY BONDS

This is not only a war for Democracy and Liberty, but a war of self-defense. Germany menaces our rights, our self-respect, our homes, and our means of livelihood.

Every citizen—every business man—has weapons of defense ready to his hand. These weapons are Liberty Bonds. We cannot all fight with guns and bayonets, but we can all fight with Liberty Bonds.

Buy to Your Utmost

Of course you have bought Liberty Bonds. Every one has. But how *many more* will you buy? The success of the Fourth Loan and of the war itself depends on your answer to that question.

Buy all the bonds you can. Go to your bank and make your arrangements. Buy more than you ever thought you could buy.

Buy to Your Utmost

This Space Contributed to Winning the War By

C. BRUNO & SON, Inc.

351-353 FOURTH AVE.

NEW YORK

Victor Wholesale Exclusively

NEW HOUSES ENTER TWIN CITY TALKING MACHINE TRADE

Great Demand for Machines Gives Opportunity for the Establishment of Two New Stores in Minneapolis—Victor Jobbers and Dealers Short of Stock—Beckwith-O'Neill Enlarging

MINNEAPOLIS and ST. PAUL, MINN., October 6.—Since the September issue of this monthly publication Minneapolis has received two new talking machine visitors. The Cheney talking machine now is permanently installed in Minneapolis after making a somewhat earlier entrance in St. Paul. In addition the Symphonola Sales Co., which formerly was located at 23 Lake street, about two miles out from the center of the city, recently has come downtown and is now ensconced at 5 Seventh street, South. C. J. Kleckner is in charge of the store and states that he has gotten away with a nice start, that the outlook is very promising, and that the Symphonola will get its share of the business.

The Cheney store, in charge of L. L. Lawson, is located at 67 Fifth street, South. This street probably has more phonograph shops than any other in the city unless it should be Nicollet. Earl C. May, an old Twin City boy, has visited the Twin Cities quite frequently of late to look after the Cheney interests, of which he is one of the chief heads.

The advent of these companies in a territory well occupied already, and with unusual conditions prevalent, tells more forcibly than the feeble words of the correspondent the actual situation with reference to talking machines in the Northwest. The companies and concerns already represented could not supply the demand and so the others came into the game.

To get a Victrola, just what one wants, a Twin City resident is compelled, figuratively, to get down on the knees and beseech. Even such humiliation will not always bring reward to a prospective purchaser, for there is not a dealer in either Minneapolis or St. Paul who has a complete line of Victor instruments. Even the big jobbing houses like the Beckwith-O'Neill Co. and W. J. Dyer & Bro. do not boast of having complete lines. Neither of them is in position to supply even a tithe of the orders showered upon them. The lot of a Victor dealer is a sad tale these days. It may be said for all of them that the only limit to their sales is the inability of the parent company or its jobbers to supply goods.

The Beckwith-O'Neill Co. is completing an addition to its record room, with a capacity of 300,000 records, raising the total capacity to 800,000. It may be added that the house never was able to keep its old record racks filled up, but why they built an addition is their business.

Two tone recital tours are under way in the Northwest under the auspices of Thos. A. Edi-

son, Inc., represented by the Minnesota Phonograph Co. Amy Ellerman is out on joint recital with Emma Seydel. These artists are touring in central Minnesota and will make the Northwestern territory. Betsy Lane Shepherd and Dorothy Hoyle are en tour in southern Minnesota. Both parties will appear in Minneapolis and St. Paul. J. W. Scott and W. H. Taylor, the latter a territorial supervisor, have been in the Twin Cities in the interests of the Edison Co.

President Laurence H. Lucker, of the Minnesota Phonograph Co., went to Chicago last week to have a heart-to-heart talk with the Edison officials in an effort to get more stock.

Passing over to the Sonora Co.'s interests, which are in the hands of the Minneapolis Drug Co., with Sewell D. Andrews in charge, it will be stated that the company and its representatives are satisfied, wholly so, with the results of their efforts for the past year. The local dealers in Minneapolis, namely, J. W. Thomas & Co., and the Watson-Marshall Piano Co., are doing a steadily increasing Sonora business. New accounts have been opened right along, the September list including the following well-known business houses: Clayton A. Deits, Groton, S. D.; C. M. Fallon, Rapid City, S. D.; Frase & Beyer Furniture Co., Fairmont, Minn.; C. W. Wilcox, Miller, S. D.; A. F. Osweiler, Marshall, Minn.; J. F. Penheiter, Minnesota Lake, Minn.; Roslyn Drug Co., Roslyn, S. D.; Wagner Drug Co., Corwith, S. D. All of the foregoing are rated as first-class business houses in their respective communities. C. H. Jaquet is covering North and South Dakota as special salesman and presumably will report a number of new accounts. The Sonora obtained an excellent introduction to South Dakota folks at the South Dakota State Fair at Huron, where N. T. Lund, the local dealer, exploited the Sonora with much success.

Brunswick phonographs are making a sure headway in the Northwest through the efforts of E. L. Kern, one of the directors of the Brunswick-Balke-Collender Co. The company has issued some exceptionally fine advertising which has caused much favorable comment. The company's headquarters in Minneapolis, Third street and Fifth avenue, South, have been rearranged so as to provide about 100 feet of window space for display purposes.

Mr. Kern permits the publication of the names of the following new Brunswick dealers in the Northwest: S. E. Spence, Cottonwood, Minn.;

M. O. Burrows Drug Co., West Concord, Minn.; C. E. Warner, Faulkton, S. D.; Fowler Drug Co., Mitchell, S. D.; Jones Bros., Clark, S. D.

The Butte branch has been closed and all shipments into Montana territory will be made from Minneapolis. However, L. S. Bacharach, the company's representative, will still have charge of the Montana territory with headquarters at Butte.

The Columbia business in this city is away beyond the ability of the manufacturers to supply goods. The unfilled orders in the Northwest office confirm Manager Sprague's assertion that he could have trebled last year's business had he been able to obtain the goods and carry on a suitable advertising.

The immense Pathé supply of instruments and records in the hands of the great house of G. Sommers & Co., St. Paul, rapidly is disappearing under the continued call from the country and the activities of the roadmen. Manager Jay H. Wheeler announced last August that he believed the house to be fairly well fortified against all onslaughts, but stated recently that he feared now that the holiday call might leave him in the air.

In conclusion it might be stated that if all the business men in the Northwest were as cheerful and as amiable and as optimistic as the talking machine folks the country would be filled with beatific joy from coast to coast.

THE NEW EDISON SURVIVES CYCLONE

Our readers will doubtless remember reading about the violent tropical storm that visited Louisiana the first week of last August, causing about two million dollars' damage at Lake Charles.

An interesting and amusing incident happened to a New Edison in that storm which is reported by the Berdon-Campbell Furniture Co., Edison dealer.

"We have a good story about the New Edison. The Official Laboratory Model was blown from a home in the country during the cyclone that hit Southwest Louisiana on the sixth of this month. The next morning it was found about a quarter of a mile from the home, with hardly a scratch; no records were broken, and the motor was in first-class shape. The wind blew it from a demolished home, it was rained upon, and still the Edison could play 'Keep the Home Fires Burning,' even though there was no home."

R. S. Peer, formerly assistant manager of the Columbia Co.'s Kansas City branch, is now in the U. S. Navy.

Freemen buy bonds, slaves wear them.

AMERICAN

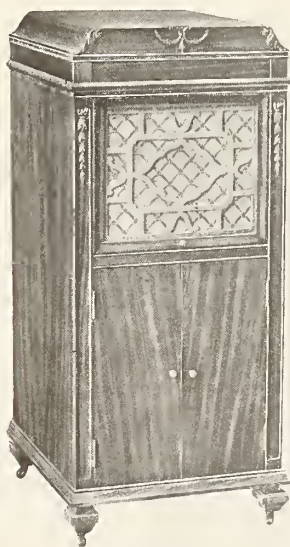

No. 22



No. 13



No. 8

Seven Models

from \$30 to \$90
wholesale

Goods that are giving
satisfaction. Guaranteed
shipment and stock for
delivery.

AMERICAN PHONOGRAPH CO., 39 Fountain St., Grand Rapids, Mich.

Buy bonds or pay taxes? Lend our capital and savings, or give them? These are the plain questions confronting us today. Our men are now where they must have munitions and supplies, which must be provided by us. We have made the main choice—that we will win this war—and there remains only the minor choice as to how we will pay the price. Bonds or taxes? Which is it to be? Your answer will be made during this Fourth Liberty Bond Campaign.

Contributed Toward Winning the War by
THE TALKING MACHINE WORLD, New York City

COLUMBIA WINDOW DISPLAY

Prepared by the Columbia Co.'s Dealer Service Department for November of Especial Interest to Members of the Industry

The November window display as prepared by the dealer service department of the Columbia Graphophone Co. for the use of its dealers embodies a timely and pertinent thought, combined with a color scheme that is striking and novel in its effect. The large central figure shows a tower clock and bears the caption heading "Longer Evenings Again," a card which is particularly appropriate to the change in time that will take place the last of this month.

Tied into the suggestion and well-balanced with the central card are two smaller ones giving a list of the new Columbia November dance and popular records. Four smaller cards feature such popular artists as Stracciari, Lashanska, Arthur Fields, Campbell and Burr, while an elongated announcement of the latest Cohan

hits by George MacFarlane lends a pleasing effect to the whole set. Eight attractively illustrated cut-out record holders featuring Seagle, Lazaro, Maurel, Baklanoff, Diero and the new



Columbia Window Display for November

Naval Reserve Band complete the display in the matter of floor material.

Of particular interest in connection with this November display is the cut-out figure showing the Serbian Tambouritza Orchestra in action, presenting their popular Columbia number "Waves of the Sea." There has been a steady demand for Serbian music that has been well taken care of by the Columbia Co.'s international record department, which has recently announced several splendid numbers by this Tambouritza Orchestra.

The Columbia monthly window display service has been conducted with gratifying results over the period of the past year, and plans are

now being made by the dealers' service department for a continuation of this service during 1919.

LANDAY BROS. IN NEWARK, N. J.

Victor Wholesalers Plan to Open Store on Broad Street, That City, the Coming Month

Landay Bros., the well-known Victor wholesalers and dealers of New York, have leased from the Prudential Insurance Co. a store on Broad street, near Market, Newark, N. J., and will open a talking machine shop there some time during the coming month. The lease calls for a record rentage of about \$900 per front foot per year.

A New and Better Reproducer used on THE "Symphone Phonograph"

PLAYS ANY MAKE of RECORDS

Gives a fine, clear and natural tone. Eliminates harsh and metallic sounds.

Write for particulars

SYMPHONE MFG. CO.
212 Telegram Bldg. TARENTUM, PA.

SEND FOR ILLUSTRATED PRICE LIST AND FREE SAMPLE

"GLOBE" TRANSFER NAME PLATES
DEALERS EVERYWHERE APPLY THEM ON PHONOGRAPHS, PIANOS, ETC.

GLOBE DECALCOMANIE CO.
JERSEY CITY, N. J.

Walter S. Gray
Chronicle Bldg., San Francisco, Cal.

NEEDLES

Pacific Coast Jobber for the Best in Talking Machine Trade Accessories



No. 100 — \$125.00

“HOFFAY”

The AIRTIGHT MACHINE
As the trade-mark reads, is

“The World’s Musical Instrument”
Increases the value of records of all makes

No. 100—\$125.00

The Home Music Leader

Unquestionably the best value on the market. Genuine mahogany, quartered or fumed oak. Metal parts nickel-plated, automatic stop, double spring motor, plays from four to five records.
Two hundred needles for Columbia and Victor Records and sapphire points for Edison. If diamond point \$5.00 extra.
Height, 44¾”, width 19”, depth 20½”.

No. 140—\$175.00

A Great Instrument

Finest construction throughout, genuine mahogany, quartered or fumed oak. Distinctive design. High class double spring motor, playing from four to five records. Metal parts heavily nickel-plated. Two hundred needles for Victor and Columbia records, one sapphire point for Edison. Diamond point \$5.00 extra. Height 47”, width 21”, depth 21”.



No. 140 — \$175.00

The Wonderful Resurrectone

With its exclusive “tuning fork” has no equal in the world. Its clearness and mellowness have the timbre and warmth of the natural voice, string or wind instruments. Forms the regular equipment for the Hoffay, but is also sold for other machines.

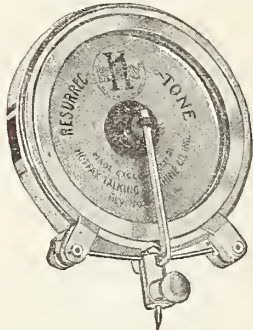

Price: Nickel-plated \$10. 22 karat gold-plated \$12.50. To fit Victors, Columbias, Sonoras, and attachments for Edison machines, etc. Money refunded if reproducer returned within 5 days from receipt.

Why and How the “HOFFAY” is Airtight

If a “string” instrument gets cracked the tone is lost. If a “singer” loses a front tooth his tone is lost. If a “cigar” gets broken the flavor is gone. The same applies to a talking machine.

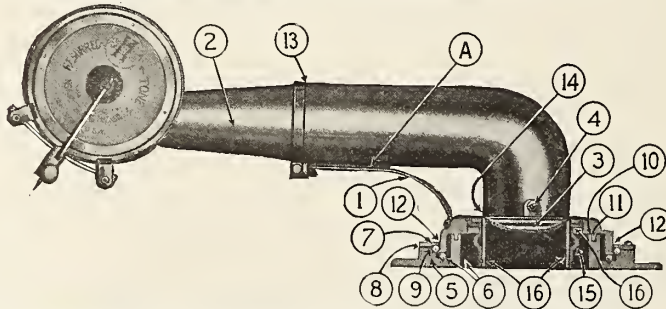

Stationary Base (5) carries double row of balls (6) and (7) upon which Revolving Base (3) turns around for the horizontal movement of tone-arm, and the joint is made airtight by Flange (10) going into groove (11) filled with yellow vaseline. Balls (6) and (7) should be kept oiled through space (12).
Space (14) permitting the up and down movement of the tone-arm is made absolutely airtight by flexible washer (15); thus a perfect anti-friction and airtight mechanism is provided with every “HOFFAY”.
Spring (1) supporting weight of tone-arm (2) is now substituted by an internal spring, the tone-arm being straight, so that no curves or joints hinder the sounds. Joint (13) is cemented and consequently airtight.

The Half-Fork

The next best reproducer. Remarkable for its clear and loud sound. It is equipped on the Hoffay wherever specially ordered. It is also sold to fit other machines.

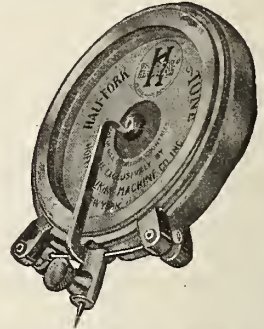

Price: Nickel-plated \$6.00. 22 kt. gold-plated \$7.50. To fit standard machines and attachments for Edisons. Money refunded if reproducer returned within 5 days.



No. 190 — \$225.00

No. 190—\$225.00

The “Second” Hoffay Choice

Elegance of style enriched by inlaid mahogany of extremely high finish, lends special charm of “finesse” to this superior instrument. Fine treble spring motor will play six or seven records. Speed regulator and automatic stop. 200 needles for Victor and Columbia records. Sapphire needle for Edison. Diamond point \$5.00 extra. Metal parts gold-plated.
Height 46½”, width 20”, depth 20½”.

No. 250—\$275.00

The Supreme Achievement in Musical Instruments

An extra smart creation, made in genuine mahogany, that symbolizes the acme of perfection. Silent treble spring motor will play six or seven records. Speed regulator and automatic stop. Metal parts are 22 karat gold-plated, 200 needles for Victor and Columbia records and one sapphire point for Edison records; diamond point \$5.00 extra.
Height 50¾”, width 20½”, depth 24¼”.

Sole Distributors for the State of Utah, Eastern Nevada,
Western Wyoming, Southern and Eastern Idaho

GEO. A. LOWE CO.
OGDEN, UTAH

Hoffay products are protected by patents granted and pending.



No. 250 — \$275.00

COMING OF FALL STIMULATES BUSINESS IN DETROIT

Cooler Weather, End of Vacation Season and Continuance of Industrial Prosperity All Have Their Effect—W. R. Woodmansee Moves and Expands—Wallace Brown's Liberty Loan Offer

DETROIT, MICH., October 7.—September was another splendid month for talking machine dealers. The cool weather, which was a complete surprise to Detroit residents, proved a big stimulant for dealers because it kept many people at home. Furthermore, the return of people from their summer homes and gasless Sundays have had a great deal to do in stimulating business. Dealers report that in their record departments they have noticed an unusual increase in their Saturday business, believing that this is accounted for by the fact that people cannot use their automobiles on Sundays and increase their number of late records for amusement. Another good reason for the splendid September business is the prosperity of Detroit and the high wages. It is true that never in the history of the city have such high wages been paid. Over 300 manufacturing plants in Detroit are now devoted to war work. Most of them work on a cost-plus basis, and it is not a question of what it costs to get out the work, but rather to get it out at any cost.

In the campaign for the Fourth Liberty Loan among those in the talking machine industry who are taking an active part are E. P. Andrew, and Ed Andrew, of the J. L. Hudson Music Co.; R. B. Alling, of the Edison Shop; E. B. Trebilcock, of the Detroit Music Co., and Sidney J. Guest, Dix avenue dealer.

The J. L. Hudson Co. starting October 1 announced to the public that it was handling three makes of talking machines—the Victrola, Sonora and Cheney. It will continue, however, to deal exclusively in Victor records. During the thirty-seventh anniversary sale of the Hudson store Manager Ed Andrew, of the talking machine department, featured a specially-made machine to sell at \$73. Mr. Andrew, by the way, who is manager of the Hudson talking machine department, spent part of September in New York City buying ammunition, explosives and war materials, for the "Battle of Viny Ridge" put on at the State Fair Grounds September 28-29 under the auspices of the Michigan State Troops, of which he has been a member since the beginning of the war with Germany.

W. R. Woodmansee has moved from 1297 Grand River avenue to 936 Grand River avenue, having purchased the stock of the Solomon & Moon Music Co., located at the latter address. Mr. Woodmansee will continue to deal in pianos, players and Columbia goods exclusively. He has been in business on Grand River avenue for the past eight years. His new location is much better than his former one, and he says himself that already he has noticed a big increase in trade.

Sam Lind, local manager for the Columbia Co., is extremely optimistic about the fall and winter business. "If the factory will stand back of all the orders we place it will prove to be the best year the Detroit branch has ever had," he said. "All of our dealers are reporting good business and are ordering more merchandise than ever. So far we have taken splendid care of our customers, and we hope to be able to do so throughout the coming fall and winter. We find a great increase in the demand for higher-priced machines, and we might add that our new period designs are taking exceptionally well."

Wallace Brown, Brunswick dealer, during the Fourth Liberty Loan, offered to pay \$10 on any \$50 or \$100 Liberty Bond for persons who would buy a phonograph priced at \$100 or over; where the purchase ran \$200 or over he offered to increase the payment to \$20. Mr. Brown says his business for the past three months has been real good, and that he is banking on a tremendous holiday business.

The Pathé Shop, formerly on Griswold street, has now officially and completely moved to its new store at 73 Broadway. This store is operated by H. N. Ness & Co.

Williams, Davis, Brooks & Hinchman Sons, Michigan jobbers for the Pathéphones and

Pathé records, are completing a very big year. During the first nine months they have gone way beyond their quota and put on some of the best furniture stores in Detroit as Pathé dealers. Having always carried immense stocks, they have been able to take good care of their customers throughout the territory. Incidentally, we might mention that every retailer of Pathé phonographs and records with whom the writer has talked recently, reports the same—"they are coming much better."

Grinnell Bros. throughout their entire circuit are doing a good Victor business, insofar as they are able to get what merchandise they can. The help situation has given them considerable trouble, especially at their main store in Detroit, where they employ so many salespeople. A great deal of the time they have been forced to close their booths on the mezzanine balcony of the first floor, owing to the lack of salespeople. Good record girls are especially hard to get.

The People's Outfitting Co., 44 Michigan avenue, recently announced having secured the exclusive Detroit agency for the Stradivara phonograph, priced at from \$95 to \$200.

AEOLIAN LIBERTY LOAN DRIVE

Through Its Windows in Aeolian Hall in Manhattan, Brooklyn, Bronx and Newark the Aeolian Co. Is Doing Great Work for the Success of the Fourth Liberty Loan

Through its windows at Aeolian Hall in Manhattan, Brooklyn, Bronx and Newark, the Aeolian Co. is co-operating with the Liberty Loan Committee in the fourth drive. For the first time the United States Government has called upon the merchants of the country for special Liberty Loan displays in their windows.

At a very patriotic and enthusiastic meeting of the National Association of Window Display Men held at the Hotel McAlpin recently, F. W. Vreeland, of the Aeolian Co.'s advertising department, tendered the co-operation of the company for this drive in arranging special window displays at the different branches. In view of the superior locations and magnitude of space afforded by the Aeolian windows, this offer received marked attention at the meeting and won expressions of special appreciation on the part of the Liberty Loan Committee.

At the present time the show windows in the



Read the Trade Mark carefully, hear the machine, and you'll agree that it is truly

The World's Musical Instrument
Improves All Records

Send for our Special Proposition
HOFFAY TALKING MACHINE CO., Inc.
3 West 29th Street New York City

For the duration of the war the semi-annual furniture exhibits at Grand Rapids will be abandoned. While there will be exhibits there will be no concerted effort along those lines. In the past quite a number of talking machine manufacturers have found these semi-annual affairs productive of good business. Some manufacturers will continue to make permanent exhibits at some of the exposition buildings.

It is expected that the Detroit Talking Machine Dealers' Association will resume their regular monthly meetings some time this month. It is likely that some action will be taken to co-operatively urge the public to do their Christmas shopping early in accordance with the request of the National Council of Defense.

The Vitrola talking machine, which is made in Chicago, Ill., and handled in this city by Weil & Co., Geo. C. Wetherbee & Co., and the Buhl Sons Co., is much in demand, according to the reports from these distributors. The latest designs are highly praised.

various Aeolian Halls throughout the city contain remarkably effective and artistic Liberty Loan displays. The window at Forty-second street in particular is surrounded daily by crowds of passers-by, who are keenly interested in the splendid display that is presented in behalf of the Loan drive. Aeolian window displays have for many years won the enthusiastic praise of professional window decorators in New York and several authorities who attended the association meeting at the McAlpin commented at length upon the artistic conception of the Aeolian displays.

THE TIME FOR THE ACID TEST

This is the psychological time to study advertising as never before—to study it not for immediate results, but for the effect that it will have in maintenance and development after the war.

Elimination of advertising at this time indicates that the manufacturer does not expect to stay in business until the dawn of peace, and yet his whole thought should be focused on keeping things going until that welcome hour.

THIS ALBUM MADE US FAMOUS
by selling it. Why don't you try?



Buy Your Albums Direct From the Manufacturer

43-51 W. Fourth St.
New York, N. Y.

THE BOSTON BOOK CO., Inc.

The only exclusive Record Album Factory in the world.



Two brilliant successes in the October Mid-Month List—"Smiles" and "How I Hate to Get Up in the Morning."

Columbia Graphophone Co.
NEW YORK

SPALDING TALKS ON MUSIC AND WAR

Former Edison Star, Now an Aviator in Italy, Tells How the War Will Make Music More of an Essential Than Ever Before—A Sensible View of German Music and Musicians

Albert Spalding, known formerly as "America's greatest violinist" and who is now a lieutenant in the American Aviation Service serving in Italy, is interestingly quoted in the New York Sun on "Music and the War." When asked to express his views in regard to musical Italy and the effect in general that the war will have on music Lieut. Spalding had the following to say in part:

"It is my belief that music will take a more prominent place in people's lives, and, in fact, is taking a more vital place now than ever before. Guglielmo Ferrero, the historian, once said 'Art is a pleasure without a need.' I wonder if he would repeat that statement to-day. Life, from a material standpoint, has during these past four years come to be made of sterner stuff than it was in the inconsequential days which preceded the great war.

"People have sacrificed and suffered to the utmost extent. Material pleasures have had to be given up one by one. Distractions, lux-

uries and manifold interests have narrowed themselves down and become merged into one great spiritual, mental and physical effort—winning the war for democracy.

"The psychological result of this will be to prepare and fit people more for the great consolation and mental uplift that art, and especially music, can give. For the pleasures of the body will be substituted the pleasures of the mind, by necessity at first and by choice afterward. Books will be read, pictures looked at

individual freedom of thought to a military cross of iron.

"A Germany that would repudiate her Hohenzollerns and Hindenburgs might some day in the future have something to say to us in art, but as they stand to-day Goethe, Beethoven and Kant would renounce and disinherit them as followers."

"What place do you think America is going to take in music? Do you think that she has a future in the art of music?" the interviewer asked.

"Most certainly," replied Lieut. Spalding. "Even before the war there was an awakening throughout America to the great need for artistic expression by the artist himself and artistic experience by the layman. And now more than ever with the sacrifices and trials and with the purification that comes by fire. American men and women will turn to music for consolation and for the expression of their thoughts and ideals. And why should we doubt that a nation that has already produced great writers, great painters and great architects should be able also to produce great musicians?"

Edison dealers and the musical public are thoroughly familiar with the art of Albert Spalding through the many Re-Creations made of his playing and they know that he speaks with authority. His entire career, both as artist and man, is one of which America can feel justly proud.



Lieut. Albert Spalding

and music listened to with greater attention, interest and concentration than ever before."

When asked what his views were on German music, Lieut. Spalding said, smiling:

"I do not believe in excluding all German music, but I believe that we should only listen to music of dead Germans. There are two reasons for this: First, because it is good music; and, second, because the Germans who wrote it are dead and a dead German is better than a living German. Bach, Beethoven, Mozart, Schubert, Schumann and Brahms have nothing to do with the hellishness of the Hohenzollerns and Hapsburgs. Their utterances are heaven storming proclamations of nature's beauties.

"We have more right to the heritage of their beauty than has war-mad Germany of to-day. We are more their followers in our ideals and aspirations than the Germans are, and why should we deny ourselves the privilege of listening to them simply because the unhappy land from which they came has since run amuck—temporarily we hope—from the poisons of Nietzsche and Bernhardt? Modern Germany has produced many clever musicians, many efficient musicians, but in my opinion their lasting value is nil.

"A nation whose avowed purpose is the triumph of materialism cannot produce spiritual results worthy of the name and the same ruthless hand that burned the library at Louvain and pointed the guns of destruction at Rheims, Paris and Venice has for forty years been nailing all true artistic effort and impulse toward

INCREASE YOUR SALES
Mr. Edison Dealer, with the
KENT Attachment
and Sound Box



Patented March 2, 1915

SIMPLE AND ACCURATE

Made by manufacturers who have specialized in Edison attachments for years.

SEND FOR ONE TODAY

Most Edison jobbers handle our products. If yours does not send direct.

F. C. KENT & CO.

Manufacturers of Phonograph Accessories

COR. MULBERRY AND CHESTNUT STS., NEWARK, N. J.

"Does It Play All Records?"

Certainly MAGNOLA does; and without any extra attachments, too. This is only one feature, albeit a most important one, in the thoroughly up-to-date equipment of the MARVELOUS MAGNOLA.

MAGNOLA "Built by Tone Specialists"



Watching the Music Come Out

May we send you our handsome illustrated catalog check full of information concerning the wonderful construction system of Magnola and the beauties of its musical results, its artistic appearance and its moderate price?

Send your name and let us tell you more!

MAGNOLA TALKING MACHINE COMPANY

OTTO SCHULZ, President

General Offices
711 MILWAUKEE AVENUE
CHICAGO

Southern Wholesale Branch
1530 CANDLER BLDG.
ATLANTA, GA.

Creating Maximum Customer Satisfaction With Minimum Merchandising Effort :: By Arthur H. Cushman

Director of Sales, Emerson Phonograph Co.

Maximum customer satisfaction with minimum effort in the sale of goods is obtained by supplying the purchaser with the merchandise he desires at the time he wants it.

When a customer enters your store and says, "Give me this list of records," naming four popular selling numbers, and your clerk goes to the shelves, promptly wraps the records, gives them to the customer and takes payment, you have made a satisfied customer with minimum sales effort.

Such a transaction seems simple enough, but for a dealer in talking machine records to perform such service regularly, and without serious interruption, means that he has accomplished the almost impossible; however, the nearer the dealer approaches this ideal situation, the more completely he has solved the problem of maximum satisfaction to his trade with minimum sales effort.

Aside from display and the advertising of the merchandise the elements entering into the successful conducting of a store may be divided into two general factors:

1. The merchandise desired by the customer on hand and ready for delivery at all times.
2. Prompt and efficient sales service.

The first one is of greatest importance, and has a very great influence on the ability to give the latter:

How may a dealer have on hand in his store a complete stock of records at all times? The average dealer will immediately say the essential requirement is prompt service by the manufacturer; but is this wholly true? It is not. The factors which bring about this condition in a store involve the co-operation of both record manufacturer and dealer. Each one is much dependent on the other. Unless the dealer, by careful system properly installed in his store and faithfully carried out, anticipates his requirements at the earliest possible moment, the manufacturer's service to him is bound to be seriously impaired.

It is my firm conviction that 50 per cent. to 75 per cent. of the dealer's inability to receive his record requirements at the time he needs them is due to lack of initiative on his own part and his failure to place orders promptly for the records needed. His needs could have been foreseen long before the orders were placed had he given sufficient consideration to intelligent stock control and reordering to replenish his stock.

I have before specifically emphasized the fact that the dealer should have a careful system by which his stocks are kept at a minimum and his service at a maximum by installing in his record department an accurate system for keep-

ing careful account of his sales and the condition of his stock.

A dealer should go a great deal further than this. He should at least once a week note not only that the records which he is selling are promptly reordered, but should adjust his "stock limits" on these records in a proper ratio to the sales.

For instance, if a dealer, when "Over There," one of the biggest selling records of recent years, was brought out, placed an initial order for 100 records and proceeded, by a proper system, to reorder from day to day, the exact amount his books showed his sales for this record would have been constantly out of this record unless he raised his "stock limit" substantially, as 100 records, with the rapidity with which "Over There" sold, would not have given a sufficient lapse of time to get orders in at the factory or the jobber, and receive them before he would have been out of stock. If, however, the dealer, seeing that the sale was daily growing harder, had raised his "stock limit" from 100 to 200, 300 or 400, as the case may be, and besides raising his "stock limit," continued to send his orders in promptly for his daily sales, he then would have had at all times sufficient leeway in stock, with reasonable co-operation in shipment on the part of the manufacturer, to take care of his trade.

My investigation, however, has shown me that very few dealers work on this principle. I am absolutely sure that no dealer can give prompt service on records to his trade regardless of how quickly the manufacturer fills his order, unless he has a system by which weekly he is able to get records of sales so that he can intelligently increase or decrease the "stock limit" on his popular selling records.

Therefore, I want to impress upon every dealer the importance of first maintaining a "stock limit" on the popular selling records in his store in a proper ratio to the sale and then keep a constant inflow of orders to the factory for replacements on these numbers, as indicated by his daily sale. That is all the dealer can do, but if he does this it will only be in rare instances that the factory will fail to keep him supplied.

Failure to maintain such a system means customers coming into the store and calling for numbers which the dealer is out of, and this is "sand in the bearings" of the sales machinery and greatly decreased customer satisfaction.

The second factor which I wish to take up is entirely within the control of the dealer, and that is service. The first detail in this is a proper arrangement of his record stock so that any record which he has in stock is immediately

available for delivery to the customer. A poorly arranged record department results in salespersons not knowing what records are in stock or where they are and is "sand in the bearings" again, and no dealer can escape the blame for this himself.

The salespersons who do not know the stock and are not familiar with the records and are therefore unable to give prompt attention to the customer add more "sand in the bearings" and the machinery is slowed up to a still greater extent, as delay is bound to occur not only in giving satisfactory service to one customer, but to others who are waiting their turn.

Proper arrangement of stock, thorough knowledge on the part of the salesperson of the stock, means the necessity of less clerk hire, which is a great essential at this period. It should be the striving of every dealer in phonograph records to get the greatest possible efficiency from his clerks. This means minimum sales effort, and minimum sales effort spells profits.

Failure to supply customers' requirements means an effort expended in convincing the prospective customer that he should buy other merchandise than that asked for, and is effort and energy unnecessarily expended unless this effort is put into effect after the customer's wants have been supplied, and then it should be applied to increasing sales, as may be legitimately done. It then becomes minimum sales effort for increasing business. A well-regulated, carefully organized store should only take up such selling after the customer has been completely satisfied as to the merchandise he knows that he desires.

If the dealers in phonograph records will operate a plan for keeping stock, as I have suggested, co-ordinate it with prompt service on the part of the clerks, together with intelligent understanding of the stocks in the store, he will, in the final analysis, create maximum customer satisfaction with minimum sales effort.

SALESMANSHIP ANALYZED

The word "salesmanship" we find has three syllables. The first is sales. Sales, taken in the sense of sail, suggests activity, life, action, a definite course, a pilot—mastery. Seek, and you will find in the word "salesmanship" all the laws and principles of success in selling. The next syllable is man. Man here suggests ability, honesty, integrity, sincerity, courage, strength, perseverance, manhood and all that measures up to 100 per cent. efficiency. The third syllable is ship, which suggests progress—success. It is a wonderful word, a magical word. Does it not live and breathe!

The "Liberty" Stylus has "Made Good"



Every Dollar of our profits goes into Liberty Bonds.

THIS semi-permanent needle, playing from 100 to 300 records, is now being sold by some of the most successful jobbers in the country.

It is the only semi-permanent needle on the market that can be used, removed at any time and replaced in the needle holder without lessening the tone quality or damaging the record.

The Liberty Stylus is manufactured in full, medium and soft tone, and is marketed in packages of three needles to a package, 50 packages in a box.

Samples to the trade free upon request

LIBERTY STYLUS COMPANY

DETROIT, MICH.



Every Dollar of our profits goes into Liberty Bonds.



Dance time is here again! Look over the new Columbia Dance Records, and go after the folks who like to dance.

**Columbia Graphophone Co.
NEW YORK**

VALUE OF WELL-DRESSED WINDOW

How a Grafonola Shop Utilizes Material Prepared by Columbia Dealer Service Department to Good Purpose—How It Is Arranged

The accompanying photograph shows the well-dressed window of a Grafonola shop in a nearby city whose proprietor evidently believes



An Excellent Columbia Display

in the efficiency of the material prepared by the Columbia dealer service department.

The principal features of the arrangement are the Grafonola K-2 and the life-sized cut-out of Pablo Casals, which forms an effective tie-up with newspaper advertising and the appearance

of this famous artist at a nearby theatre. In the central background is seen a framed photogravure of the Chicago Symphony Orchestra, a picture of considerable interest to all who have heard this successful organization either on the stage or through the medium of Columbia records.

In the center of the window is a record tree fixture holding five Columbia window display records which are such faithful reproductions of the regular product that they cannot be detected as imitations four feet from the eye. In the central foreground is a Columbia brass sign mounted on heavy mission finished oak for display in available spaces in the interior or outside of the store.

The smaller articles are a midmonth hanger in a metal easel frame and two cut-outs from the dealer service monthly window display. A Columbia monthly supplement on the floor of the window suggests that new lists of Columbia records are on sale and constitute an invitation to passers-by to enter the store and hear them.

HOW TO SAVE MONEY

The surest way to make money is to save money, and there is no surer way to do so than to buy Liberty Loan Bonds; thus you help yourself and help the nation win the war.

He who has conquered his own coward spirit has conquered the whole outside world.

DISCUSSES THE NEEDLE SITUATION

President Tauber, of Progressive Phonograph Supply Co., Tells of Price Advance—Has Just Left on Extended Western Trip

D. Tauber, president of the Progressive Phonograph Supply Co., sole distributors for the Wall-Kane steel needles, left last week for an extended Western trip, which will include a visit to the leading trade centers in the South and Middle West.

Before leaving Mr. Tauber commented upon the fact that the demand for Wall-Kane steel needles is constantly increasing and that notwithstanding the increased price for these needles, which went into effect last month, the orders received from the company's jobbers are far in advance of any period in the company's history.

Discussing the price situation, Mr. Tauber said: "Last month we announced a new price list to the trade, this being the first increase in the price of Wall-Kane steel needles since we placed our product on the market. We held up this advance until the last minute, but the tremendous increase in the cost of raw materials and labor made an advance absolutely necessary. At the same time, however, the price of the Wall-Kane steel needle is 50 per cent. lower, as compared with the average steel needle, taking into consideration the number of records that a package of Wall-Kane steel needles will play. Whereas we have only advanced our prices recently, practically every other steel needle has been increased in price two or three times during the past year. We are making plans to take care of a record-breaking fall business, and feel sure that our clientele will receive satisfactory service."

PLANS FOR A GREAT FALL TRADE

ATLANTA, GA., October 4.—The Diamond Disc Shop, at 9 West Alabama street, in this city, is closing a splendid business, and H. N. Purdy, manager of this establishment, is making plans for a record-breaking fall and holiday business. August and September sales were phenomenal, showing a gain of 250 per cent. over last December, and the store closed three times as much business in the month of August as it closed in December, 1917.

Mr. Purdy has spent several years in the retail phonograph business and is an enthusiastic admirer of the Edison Diamond Disc phonograph. He thoroughly understands and appreciates the musical and sales possibilities of this instrument, and his familiarity with this product, combined with the aggressiveness of his sales staff, has been an important factor in the success achieved by the Diamond Disc Shop.

It is easy to learn all the notes that make good music, and all the rules that make good business, but a fellow's got to add the fine curves to them himself if he wants to do any more than beat the bass drum all his life.

MELOPHONE MOTOR

No. 1

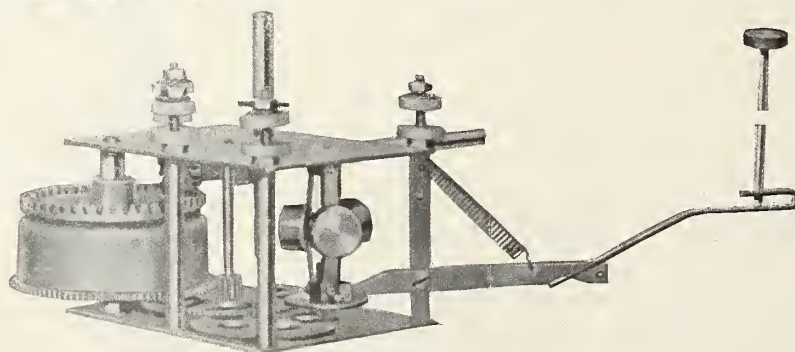

No. 1

COMPLETE WITH 10-INCH TURN TABLE

Simple in construction, the most satisfactory and durable of all small motors.

Will play two ten-inch records with one winding.

Three years' successful record as the best single spring motor manufactured.

Immediate Deliveries

Sample \$2.00

Write for Quantity Prices

Melophone Talking Machine Co.

380 Lafayette Street, New York

MORE CONVINCING PROOF OF WORLD ADVERTISING RESULTS

The Art Craft Co., Grand Rapids, Telegraphs of Unexpected Volume of Inquiries From Announcement—Indicates That Consistent and Persistent Advertising Always Wins Out

The accompanying unsolicited telegram received at the office of The World from the Art Craft Co., Grand Rapids, speaks volumes for the supremacy of The Talking Machine World

has been authorized for use in the October issue. There is no doubt but that The Talking Machine World can be used to excellent advantage by every talking machine manufacturer whose

CLASS OF SERVICE	SYMBOL
Telegram	
Day Letter	Blue
Night Message	Nite
Night Letter	N L

If none of these three symbols appears after the check (number of words) this is a telegram. Otherwise its character is indicated by the symbol appearing after the check.

WESTERN UNION TELEGRAM

NEWCOMB CARLTON, PRESIDENT GEORGE W. E. ATKINS, FIRST VICE-PRESIDENT

Form 1201

CLASS OF SERVICE	SYMBOL
Telegram	
Day Letter	Blue
Night Message	Nite
Night Letter	N L

If none of these three symbols appears after the check (number of words) this is a telegram. Otherwise its character is indicated by the symbol appearing after the check.

RECEIVED AT

M26 CPD MB 49NL 3 EX

GRANDRAPIDS MICH OCT 2 1918

TALKING MACHINE WORLD

373 4 AVE NEWYORK N Y

Our Add in Sept Issue of Talking Machine World Has Brought Unexpected Results In Such A Short Time This Experience Verifies The Belief That Good Merchandise Advertised In The Proper Way Will Bring Results You May Rest Assured That We Will Continue Space In Your Paper

The Artcraft Co.

E W Simpson

726PM

in this industry and the tremendous drawing powers of advertising in its pages. The Art Craft Co. used a full page advertisement in the September number announcing a new line of high-grade machines. As the telegram indicates, this advertisement produced unexpected results, and another full page advertisement

product is worthy of consideration by the trade. As The World reaches the progressive dealers in every part of the country, it offers the manufacturer an opportunity to keep his name before the trade month after month and build up a good will for his product that is invaluable and cannot be measured in dollars and cents.

AMBEROLA SALES IN CANADA

Increased Prices No Hindrance to Trade, Canadian Dealers Find

Coming at this time, following the recent announcement of an increase in United States prices of Edison instruments, a comparative statement of Amberola sales in Canada since that country has been at war is fraught with tremendous importance and significance to every United States Edison dealer.

Taking the total sales in Canada of Amberola instruments and records for the years 1915, 1916, 1917 and the first quarter of 1918, the following percentages of increase in volume of sales are shown:

1916 over 1915, 41 per cent. increase; 1917 over 1916, 62 8/10 per cent. increase; first quarter of 1918 over same period of 1917, 82 1/2 per cent. increase.

This increase of sales is even more striking when it is considered that in 1916 and 1917 the import duty averaged 37 1/2 per cent., whereas in 1918 this duty was raised to 50 per cent. And in spite of that the increase in volume of sales for the first quarter of 1918 was 82 1/2 per cent.

From an analysis of the foregoing it becomes evident that the higher retail price of Amberolas and Amberol records in no way hampers the sale of this merchandise. We must also consider that Canada differs from the United States in that that country has been at war since 1914, whereas we here have been in the conflict only a year and a half. It seems that these figures of actual results obtained should inspire every Edison dealer with the knowledge that an increased retail price does not interfere with the demand for the merchandise he has to offer.

WRONG TIME TO CUT DOWN

Cutting down advertising in slack times is an example of "penny wise and pound foolish." Advertising is like a magician's bag—more comes out of it than was put in.

WHEN YOU FIGHT—FIGHT!



Fight as these American soldiers fought in the streets of Fismes.

"They covered themselves with glory," the papers say. Of course they did—they are Americans.

They met the finest of the enemy troops in a terrific hand-to-hand struggle. They used their guns—their bayonets—their bare fists. Every American soldier went after his man desperately, fearlessly, persistently, with one great driving purpose—to whip that Prussian Guard, to silence its machine guns—to win!

It's a pretty good way to fight—this American way. It wins battles over there, it will win a splendid Victory over here—if we fight when we fight—if we buy Liberty Bonds to our utmost.

When you fight—FIGHT! When you buy—BUY!



PARIS, Aug 5.—The Americans covered themselves with glory in the hand-to-hand fighting in the streets of Fismes yesterday when they captured that German base. The fighting is said to have been the bitterest of the whole war, the Prussian Guards asking no quarter and being bayoneted or clubbed to death as they stood by their machine guns.



Silas E. Pearsall Co. Wholesale Distributors of Victrolas and Records 10 East 39th Street New York

Silas E. Pearsall Co. Wholesale Distributors of Victrolas and Records 10 East 39th Street New York



**If there's a problem that's bothering you—
put it up to the Dealers' Service Department.
That's what they're for.**

**Columbia Graphophone Co.
NEW YORK**

MILWAUKEE TRADE STARTS THIRD ADVERTISING CAMPAIGN

Will Concentrate on Sales of Records and Music Rolls—About \$1,500 Will Be Spent—New Association Members—Multitone Co. to Manufacture—Bradford Co. Expansion—News of Month

MILWAUKEE, Wis., October 10.—Talking machine business is due for another boom, the Milwaukee Association of Music Industries having decided to proceed with another extensive advertising campaign for the good of the trade as a whole. This will be the third campaign under association auspices, the first having been instituted during the holiday season a year ago, and the second during last spring. These campaigns were productive of splendid results, and lest the influence and prestige built up in this manner be in any way dissipated by lack of attention it has been decided to conduct a third drive, to cover the remaining three months of the year. The association took into consideration all conditions and influences of the times before deciding to go ahead, and has adopted a plan of operation that will not interfere in any possible way with the wishes of the War Economy Board of the Council of National Defense with respect to holiday business. On the other hand, the campaign is so designed that it will co-operate in every way with the Government. The public will be urged to do its buying early and with due regard to the stress of the times.

A distinct feature of the third campaign will be its appeal for business in records and music rolls. Previous campaigns made the purchase

of the instrument the principal point. Now the supply end of the business will be placed in the forefront.

The campaign, as planned, will cost about \$1,500, which is being raised by voluntary subscriptions among members of the association in proportion to their volume of business. For the purpose of the first campaign a total of \$4,000 was raised. The spring campaign cost about \$1,200. It is believed that no local dealers' association has ever entered upon so comprehensive a scale of co-operative sales effort. Previous campaigns have attracted nation-wide attention and the idea has already been copied in several large cities of the country, either by organized associations, groups of dealers, or local newspapers.

President Henry M. Steussy, who is general manager of the Milwaukee Piano Mfg. Co., representing the Brunswick phonograph, says in relation to the proposed campaign:

"We are not going to advertise because business is bad, but because business has been good and we intend that it should remain so and improve. We are firm believers in advertising. Experience has taught us that advertising is food and sustenance for good business, just as it is medicine and stimulant for bad business."

One of the results of the music dealers' co-operative advertising is the action of the Milwaukee Jewelers' Club in undertaking a similar drive at a cost of nearly \$5,000. This began late in September and will be carried through until late in January.

Three prominent women members of the local talking machine trade have become full-fledged members of the music industries association. They are Mrs. Piasecki, wife of Col. Peter F. Piasecki, 441 Mitchell street, whose extensive phonograph business is being handled by his wife during his absence on duty in France with the famous Thirty-second Division; Miss Helen Gunnis, manager of The Music Shop, 310-312 Grand avenue, representing the Columbia and Starr, and Mrs. George H. Eichholz, widow of the head of the Geo. H. Eichholz Co., 542 Twelfth street, Victor and Edison dealer. Mmes. Piasecki and Eichholz and Miss Gunnis were guests at the September meeting of the association and at its close expressed themselves as so well pleased with the constructive work being done by the organization that they applied for membership then and there. A new addition to the ranks of male members on this occasion was Harry W. Krienitz, Victor dealer, 326 Grove street. The association is making an active campaign for new members and expects to recruit all of the better class of dealers within a short time.

The latest entrant into the Wisconsin manufacturing field is the Multitone Mfg. Co., of Eau Claire, Wis., which has been organized by E. J. Sailstadt, an old-time Columbia man, and for several years a piano and talking machine dealer of that city, to manufacture a machine of his own design and incorporating numerous new and original features. The capital stock of the new company is \$50,000, all of which is Eau Claire money. A factory was opened during the early part of last month and is now in full operation. A splendid volume of business has been booked and assures continuous production for a long time ahead. Officers of the company are: President, E. J. Sailstadt; vice-president, Dr. E. T. Finucane; secretary and treasurer, L. T. Roberts. Frank Dassow, formerly of the Steger factories, Steger, Ill., is with the company as designer and superintendent.

The Hoeffler Piano Mfg. Co., 304 West Water street, this city, one of the leading automatic instrument houses in Wisconsin, is making an effective campaign in behalf of the Seeburg Phono-Grand. This combination phonograph and piano is establishing a wide popularity in this city and is being placed in some of the best homes.

"More business than we can take care of," is the succinct comment on business conditions made by the local branch of the Brunswick-Balke-Collender Co., of which Thomas I. Kidd is manager.

Charles J. Orth, 504 Grand avenue, distributor of the Puritan in Wisconsin and Upper Michigan, is earning the reputation of being the most consistent advertiser among Milwaukee talking machine men. Hardly a day passes without an



Pathe for Profits



Phonograph dealers should investigate the wonderful merits of the

Pathe Phonographs and Records

By dealing through us
you have the assurance of

**Prompt Deliveries
Real Service**

**Co-operation
Sales Help**

Write us today

THE FISCHER CO.

(Oldest Pathe Jobbers)

940 Chestnut St.

Cleveland, Ohio





PERSONAL SERVICE

The members of our Company are always available and will gladly see you personally or write you at any time we can possibly serve you.

Why not communicate at once with us?

BADGER TALKING-MACHINE CO. 135 Second Street
MILWAUKEE, WIS.
VICTOR DISTRIBUTORS

Orth display in one or more of the daily newspapers of Milwaukee. Mr. Orth writes his own "copy," and for originality and effectiveness no better run of advertising has ever appeared in this city. The steadily mounting volume of Puritan sales is ample proof that his work is bringing results.

The J. B. Bradford Piano Co., which retails the Victor in its main store at 411 Broadway, and the Sonora in its South Side store at 596 Mitchell street, is coming to be one of the most important retail talking machine interests in Milwaukee. The Mitchell street store was opened only two months ago in a permanent location, although a branch has been maintained for more than a year. It is proving to be one of the liveliest Sonora agencies under the jurisdiction of the Yahr & Lange Drug Co., Sonora distributor in Wisconsin and the Upper Peninsula. The Victrola department on Broadway has recently been remodeled and tripled in size and is now under the complete charge of S. F. Patchin as manager. Miss Ruby Knox, formerly in charge of the music roll library, has been appointed to the same position in the record department.

The Gether Piano Co., 625 Grand avenue, this city, reports a constantly growing Pathephone business. During State Fair week the company maintained a booth at the fair grounds, where it featured the regular \$90 Pathé Solophone at \$75, including new Universal tone-arm and twenty records.

The Squier Store, Rhinelander, Wis., which maintains a Victrola department in connection with its jewelry business, has moved into new quarters, in which about twice the former floor space is available. The store is conducted by Mrs. Edward G. Squier, one of the best known business women of Northern Wisconsin.

Paul Wachs, expert adjuster and repairman for Charles J. Orth, Puritan distributor, recently had the misfortune to lose his little son by accidental drowning while at play on the river banks.

The Edmund Gram Music House, 414-416 Milwaukee street, this city, has enlarged its Aeolian-

Vocalion department and record library to meet its growing business.

George Jewell, who retails the Edison at Rhinelander, Wis., has remodeled and redecorated his music store from "cellar to garret" and now has one of the most attractive establishments in any of the smaller communities.

INTEREST ON DEFERRED PAYMENTS

Universal Adoption of This Plan by the Retail Talking Machine Trade of Milwaukee—Association Gets Full Credit for Move

MILWAUKEE, Wis., October 10.—Unquestionably one of the most momentous developments in the retail talking machine trade of Milwaukee this year is the universal adoption of the plan of charging interest on all deferred payments, beginning October 1. After agitating the question for more than a year all elements of the trade finally have acknowledged the wisdom and necessity of this step, and from now on no sale of a machine on the instalment plan will be made unless the purchaser agrees to pay 6 per cent. interest.

To the Milwaukee Association of Music Industries, composed of talking machine and piano dealers, must be given full credit for bringing about this important progressive step in musical instrument merchandising. It has been successful in making the trade see that good business judgment makes the institution of an interest charge not only desirable but absolutely necessary, especially under existing conditions in the business. Thousands upon thousands of dollars which rightfully belong to the dealers have been cast to the winds each year because of the failure to make the purchaser pay for the use of money for which the merchant pays dearly at his bank. It is conservatively estimated that during the first year of the operation of the new plan not less than \$100,000 will be returned to local dealers in the aggregate.

The universal adoption of the interest charge does not mean that all Milwaukee talking machine dealers have not been making such charges up to October 1. A considerable num-

ber of merchants have had interest clauses in their contracts for several years past, and they have kept them there in spite of the fact that they have sometimes lost sales to dealers who did not charge interest. However, those who have been holding off for one reason or another finally have discerned the justice of the proposition and have come into the fold.

"I consider it one of the most important steps the talking machine trade of Milwaukee has ever taken," said Richard H. Zinke, manager of the Badger Talking Machine Shop, Victor retailer, 425 Grand avenue, and secretary of the Music Industries Association. "It is bound to exert a powerful influence for the betterment of the trade. It is only taking what rightfully belongs to us. All of us realize now that we have been unjust to ourselves."

ANDREWS IN RUNAWAY ACCIDENT

C. N. Andrews and His Father-in-Law Had Narrow Escape from Serious Accident in Syracuse—F. P. Besser in France

BUFFALO, N. Y., October 7.—Syracuse newspapers recently devoted considerable space to a runaway accident in which C. N. Andrews, of W. D. & C. N. Andrews, talking machine jobbers of Buffalo, figured. On a "gasless Sunday" Mr. Andrews and his father-in-law, W. H. Collins, 93 years old, were riding in a horse-drawn carriage to the New York Central station in Syracuse when the accident occurred. The team drawing their rig ran away in East Jefferson street, which was congested at the time, and was stopped after a lively run by Private J. Noel, of the U. S. Army. The soldier was dragged for nearly a block before he brought the horses to a standstill. The occupants of the carriage escaped injuries and were able to walk the rest of the distance to the station.

Fred P. Besser, formerly of Mr. Andrews' sales force, is attending an officers' training camp at Saumur, France. He is taking a special course in artillery. In this town there was formerly a famous French cavalry school which has been turned over to the Americans.

CLOCKS WILL MAKE RECOMPENSE

Those considerate people who are on the watch lest harm should come to their personal interests, or lacerations to their feelings, and who groaned in spirit when forced to push the hands of the clock ahead in the early days of spring, will soon find their recompense, says the Hardware Magazine. The hour they lost will be restored them, and the clock compelled to disgorge its sixty-minute loss. It has been, however, a great experiment, and a condition of affairs that will never be abandoned.



Reproducer

CERTAIN PATENTED FEATURES

found in PHON d' AMOUR exclusively make the PHON d' AMOUR a re-creation in the phonograph field.

The PHON d' AMOUR marks the first real departure in construction since phonographs were first offered to the public.

THE REPRODUCER IN PHON d' AMOUR

is an entirely new and greatly improved "sound box." It is finished throughout with the precision of a watch.

It is the patented features in PHON d' AMOUR that make the difference and which make this instrument the phonograph with the Soul of a Violin.



Copyright, 1917, by The Fritsch Phonograph Co. Trade Mark

THE FRITZSCH PHONOGRAPH COMPANY

228-230 West 7th Street

CINCINNATI, OHIO

NINETY PER CENT
of
**New Edison
Diamond Amberolas**
placed on trial are sold

An instrument on trial in the home generally has to stand comparison with at least one of its competitors. The best satisfied Amberola owners are those who purchased after such a test.

A thoroughly and permanently pleased instrument owner is a good record buyer.

Record sales mean profits for you.

THOMAS A. EDISON, Inc.
Amberola Department
ORANGE, N. J.

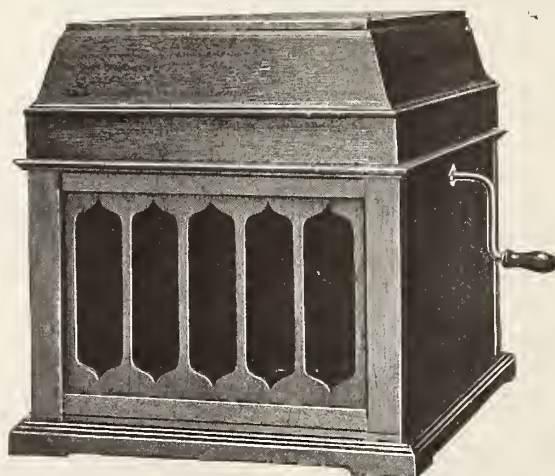

THE NEW EDISON DIAMOND AMBEROLA
MODEL 50

PHOTOGRAVURES OF ARTISTS

Framed Pictures of Columbia Artists Now Being Shipped to Dealers to Exploit Sales

Framed photogravures of Columbia artists are now being shipped to Columbia dealers by the dealer service department. The selection of subjects covers practically all the celebrities on the Columbia list, including instrumental organizations, such as the Chicago Symphony Orchestra, one of the most successful orchestras in the country.

The photogravure is eighteen inches by twenty-two inches in size, and is artistically set off



Framed Photogravures of Columbia Artists

by a highly polished mahogany finished frame with a gold border strip and glass. Each frame is equipped with screw eyes and wire for hanging, and is packed and sealed to prevent damage to the print by dust and atmospheric changes.

The display of Columbia artists' pictures is of great sales value to the Columbia dealer. Aside from their decorative value on the walls of the store they are a constant invitation to the customers to hear records and in many instances offer suggestions that would otherwise not occur.

GET THE VICTORY PUNCH

Get the victory punch into your business letters. Pessimism is more infectious than a cold. One doubter can give the chills to a room full of people. The germ of this disease often creeps into our correspondence and does more harm than the spoken word.

This war should teach us to do without many things except real loyalty.



The Indoor Season

will be used by many for the study of languages. This spells opportunity for you, Mr. Dealer, through the

CORTINA Phone-Method

Sell them the records, the talking machine and the text books. The Cortina Military French-English course is especially adapted for those going "over there."

Send for full information. Advertising matter and window displays free.

The Cortina Academy
12 East 46th Street :: New York

AID LOAN DRIVE IN INDIANAPOLIS

Geo. F. Standke and A. H. Snyder Among Officials of Marion County Liberty Loan Legion—Stewart Boys in Country's Service

INDIANAPOLIS, IND., October 10.—George F. Standke, manager of the Brunswick Shop, and A. H. Snyder, manager of the Edison Shop, won commissions in the Marion County Legion, the organization here which put over the Fourth Liberty Loan. Standke held the commission of colonel and had charge of Sector 46 with staff headquarters in the Brunswick Shop. Snyder ranked as a lieutenant. Colonel Standke had a particularly difficult sector, but he overcame the enemy in fine shape. The sector included one large manufacturing plant where a subscription was obtained from every employe in the plant.

Previously to the Liberty Loan drive "Colonel" Standke spent several days in Chicago conferring with the Brunswick maker in regard to getting machines to put on the market in Indianapolis. While there Standke ran on to Wallace Brown, Brunswick dealer of Detroit, who was in Chicago on the same mission.

Business is reported good among the dealers, but all have the same story as to goods—can't get enough to meet the demand.

Mr. Snyder announced that the Edison Shop has arranged for a tone demonstration in the Riley Room at the Claypool Hotel on the evening of October 28 with Madame Odette Le Fontenay, soprano of the Metropolitan Opera Co., as assisting artist.

Ben L. Brown, manager of the Columbia Graphophone Co.'s wholesale branch here, entertained all the local dealers handling the Columbia line at the Hotel Lincoln during the week of October 7. The new Columbia records were played. This was one of a series of meetings which Mr. Brown is holding to promote the sale of records, and he says the results more than justify the time spent at the meetings. Mr. Brown recently returned from a short trip over his territory. J. S. Reese and Guy Boyd, of the Columbia wholesale branch, have left for army service.

James E. Stewart and George E. Stewart, sons of A. M. Stewart, of the Stewart Talking Machine Co., are both in the service, James being with the Signal Corps stationed at Fort Leavenworth, and George with a radio division, which is believed to have landed in France. James Stewart formerly managed the Stewart retail store at 110 North Pennsylvania street. Emerson Knight, formerly advertising director for the Stewart Co., has arrived in France. He is attending an officers' training camp for marines there, having had his preliminary training in the United States.

GET IN TOUCH WITH THE FARMER

How the Talking Machine Man of the Town Can Help His Business Materially

If the proprietor of a good store can make it a point to go around through the surrounding country and stop and talk over the fence with a lot of the farmers he sees he can help his store more than he has any idea. If a farmer says "Can't you come in and stay to dinner?" go in and stay. The average farmer is never better pleased than when he is showing hospitality to some of his town acquaintances. He likes to be able to show you that he is not a fool. He feels at home out there among his possessions, and he has something to be proud of, though with less people to find it out than the man in town. He likes things to happen to break into the monotony of his life, and the man who can make them happen for him will be his friend. He likes the man who will fraternize with him without a shadow of patronizing. You can't patronize anyone long—at least the farmer—and retain his trade.

Advertising success depends upon three factors—space, copy and reader. Study all three and win.



No. 1410 Rim Table for Victrola IX or IXA Mahogany Holds 5 Victor Albums

Conserve Selling Energy with UDELL Cabinets

Salesmen are scarce. Their time and efforts have double or triple value. Every minute saved in a selling talk means money.

UDELL Cabinets are in designs that please. Their appearance attracts the customer, and the UDELL reputation for quality clinches the deal.

They are as near "self-selling" as a cabinet can possibly be. Get in touch with us and let us convince you.

You yourself know what UDELL means on a cabinet.



TRADE MARK

THE UDELL WORKS

1205 W. 28th Street
INDIANAPOLIS INDIANA

ISSUE COMPLETE RECORD CATALOG

Important Publication Just Issued by the Otto Heineman Phonograph Supply Co. Embraces the Entire List of "OkeH" Records

The Otto Heineman Phonograph Supply Co., New York, has just issued a complete catalog of its "OkeH" records, this publication being the first featuring this record line that has yet been introduced to the trade. The catalog, which is attractively compiled, gives a fair indication of the pleasing success achieved by this record line in the comparatively short while it has been on the market.

The "OkeH" records in the new catalog are arranged according to classes of music, the headings being distinctive and the use of small thumb-nail illustrations of the artists giving a personal touch to the pages that makes them very attractive. Among the artists whose photographs are presented are Reed Miller, Grace Kerns, Henry Burr, Paul Eisler, Byron H. Harlan, Arthur Collins, Joseph Philips, Inez Barbour, Frank Croxton and others. All of these

artists are popular with music lovers, and their "OkeH" records exemplify their ability in the recording art.

The many divisions under which the records are grouped enable the "OkeH" dealer to present this catalog to his patron with the assurance that it will afford maximum convenience and enable him to find the desired record instantly. Among the different headings under which these records are listed are dances, Hawaiian music, heart tunes, humorous, instrumental, Irish, marches, patriotic, popular songs, sacred numbers, standard and familiar operatic selections, quartets and trios, Southern melodies, etc., etc.

"OkeH" dance records have won much favor with the dealers handling this line, and among the artists recording for the dance library are the well-known Van Eps Banjo Quartet, Rega's Novelty Dance Orchestra, the Majestic Hotel Dance Orchestra and other popular organizations. The humorous selections are recorded by Collins and Harlan, George Thompson, Arthur Hall and other artists who have achieved success in recording these difficult records. The

instrumental selections are especially worthy of comment as Otto Heineman, president of the Otto Heineman Phonograph Supply Co., is devoting a considerable part of his time to supervising the recording of standard instrumental numbers that will meet with the approval of discriminating music lovers, and which can be offered to the public at nominal prices. The Berkshire String Orchestra contributes several numbers to the "OkeH" library, and there are several 'cello records made by Vladimar Dubinsky that have met with a ready sale.

AEOLIAN-VOCALION PUBLICITY

Series of Newspaper Advertisements Prepared for Dealers Just Issued

The advertising department of the Aeolian Co., New York, has prepared for the use of Aeolian-Vocalion dealers a splendid series of newspaper advertisements that can be featured to excellent advantage during the fall season. Before being offered to the dealers these advertisements were carefully tested in the local newspapers, and Aeolian-Vocalion representatives can use this series with the assurance that this publicity has "made good" under difficult conditions.

The Aeolian-Vocalion phonograph, because of its many distinctive features, adapts itself admirably to newspaper advertising, and the different advertisements offered to the trade combine prestige text with effective sales argument. Cuts are furnished free of charge to the dealers in any size that is desired, and there is no doubt but that the proper use of this advertising will act as an impetus to the sale of the Aeolian-Vocalion phonograph.

ENDORSES "MADE IN U. S. A." MARK

Merchants' Association Goes on Record as Favoring Adoption of That Marking

The Merchants' Association of New York has adopted the following resolution endorsing the proposed use of the marking, "Made in U. S. A." on all goods manufactured in the United States as urged by the Bureau of Foreign and Domestic Commerce in Washington:

"Whereas, We believe that the best interests of our country are served when all goods manufactured here can be readily identified at all times from goods manufactured elsewhere, and

"Whereas, We believe that the identification of the country of origin of any goods is facilitated by the use of a single designation of origin, and

"Whereas, We believe that the designation 'Made in U. S. A.' in plain type form, is the best means of identification of goods manufactured in the United States of America; therefore, be it

"Resolved, That the Merchants' Association of New York recommends that the designation 'Made in U. S. A.' in plain type form, be used by all of its members on all goods manufactured by them in the United States of America, and that the use of all other markings to identify the country of origin of such goods be discontinued."

MAKING 12,000-MILE TOUR

Florence Ferrell, the popular New England lyric soprano, and Grace Freeman, the well-known California violinist, are off on a twelve thousand mile tour in the interests of the New Edison. Commencing in Armour, S. D., on September 16, Madam Ferrell has been booked in Tone Test recitals continuously until the middle of December. Her route will take her through South Dakota, Nebraska, Colorado, Wyoming, Utah, Idaho, Washington, British Columbia, Oregon, California, Nevada and Arizona. Madam Ferrell covered a portion of this same territory last spring and her success was so great that she was immediately rebooked wherever she went.

Liberty Bonds speak louder than words.

A Frank Discussion



Eight Models
Retailing from \$30 to \$275

¶ There are more than a hundred phonographs that have been presented to the trade recently by different manufacturers. They ALL claim superiority of every detail—cabinet design, finish, motor, tone, etc. It is very clear that ALL these instruments cannot be BEST. Some of these manufacturers are at least mistaken.

¶ You recall many things that were seemingly satisfactory until BETTER ones appeared. That is exactly the case with phonographs—the instrument of yesterday "paved the way" and to-day

there is but ONE best in phonographs, the SONA-TONE—it is the NEW PHONOGRAPH and BETTER, just the same as America is the NEW WORLD and BETTER.

¶ Mr. Thomas Dixon, of "Birth of a Nation" fame, says: "It is the sweetest and clearest toned instrument I have ever heard."

¶ You do yourself an injustice if you do not investigate the SONA-TONE, the last and FINAL word in phonographs. The *only* Over the Top.

¶ REMEMBER, the SONA-TONE sells on sight and it STAYS SOLD; no come-backs. Liberal trade proposition, immediate deliveries, and exclusive territory.

Write us to-day.

SONA-TONE PHONOGRAPH, Inc.

Office and Sales Room, 322 Livingston Street, Brooklyn, N. Y.

Factory, 691 Bergen Street, Brooklyn, N. Y.

DALLAS TRADE BOOSTING LOAN

Local Association Urges Subscriptions in Large Advertisement in Public Press

DALLAS, TEX., October 7.—The Dallas Music Trades Association, of which J. C. Phelps is president, is lending its support to the Fourth Liberty Loan in a very practical manner. In the Dallas News of Monday, September 30, a half-page advertisement was inserted, signed by sixteen members of the local Music Trades Association, calling upon the citizens to have their subscriptions ready early in the campaign. The work of taking the subscriptions started Monday morning, and during the hours of 9 to 11 a. m., a host of canvassers covered the business section of the city, securing subscriptions. Many prominent members of the music trade in this city were among the solicitors, and latest reports indicate that Dallas will oversubscribe its quota by a very substantial amount.

The Field-Lippman piano stores also gave publicity to the Fourth Loan through the medium of a well-written advertisement, which not only boosted the loan, but also called attention to the value of music in maintaining morale.

Discretion: the act of bluffing a chap you can't lick.

AEOLIAN RECORDS BY ROSA RAISA

Leading Dramatic Soprano Will Record Exclusively for Aeolian-Vocalion Library

The Aeolian Co. announced last week through the medium of effective newspaper publicity that Miss Rosa Raisa, well-known dramatic soprano, would hereafter make records exclusively for the Aeolian-Vocalion record library. Miss

Greatest Living Dramatic Soprano



ROSA RAISA
has been followed by world critics both here and abroad—"The greatest dramatic soprano in the world."
Of Polish birth, Miss Raisa received her musical education in Italy, under the greatest masters. She has appeared in England, Continental Europe and the South American capitals in leading operatic roles, achieving everywhere the triumphs which crowned her appearance in New York last season.
Miss Raisa is now prima donna soprano with the Chicago Opera Association, where her repertoire includes "Aida," "Les Huguenots," "Jewels of the Madonna," "Cavalleria Rusticana," "Francesca di Rimini" and "Lisbon."

ROSA RAISA
makes
VOCALION RECORDS
Exclusively

It gives us much pleasure to announce that this great artist's voice (the greatest dramatic soprano of the day, according to the vast preponderance of critical opinion) will be reproduced by means of Aeolian-Vocalion Records exclusively. Here is a wonderfully gifted singer whose finished artistry upholds the standards of the best sopranos of the last century; another superb voice that you may have in your own home—the glorious beauty and richness of it kept intact through this new and revolutionary recording process!
The first of Miss Raisa's beautiful recordings to appear is the "Vio lo sapete" (Well do you know) from "Cavalleria Rusticana." A thrilling and beautiful number, nobly sung and perfectly recorded.

Rosa Raisa Vocalion Record Publicity

Raisa's first record, "Vio lo sapete," from "Cavalleria Rusticana," is now ready for presentation to the trade, and several musical critics who have visited the Vocalion studios during the past week are enthusiastic in praising this record.

Miss Raisa received her musical education in Italy under the greatest masters. She has appeared in England, Continental Europe and the South American capitals in leading operatic roles, achieving everywhere the triumphant success that crowned her appearance in New York last season. Miss Raisa is now prima donna soprano for the Chicago Opera Association, where her repertoire includes "Aida," "Les Huguenots," "Jewels of the Madonna," "Cavalleria Rusticana," and others.

Following out its custom of introducing its artists to the public through the use of attractive advertising, the Aeolian Co. is using space in all of the leading newspapers announcing the acquisition of Miss Raisa to the Vocalion record library. This advertising calls attention to the success achieved by Miss Raisa on the operatic stage, and emphasizes the fact that she is recording for the Vocalion library exclusively. Miss Raisa's international success on the operatic stage enhances the importance of her new Vocalion records, and the dealers handling this line are enthusiastic regarding the sales possibilities of her records.

A GROWING TEXAS INSTITUTION

The Texas-Oklahoma Phonograph Co., Under Management of Mr. Curry, Moving Ahead

DALLAS, TEX., October 7.—The Texas-Oklahoma Phonograph Co., with headquarters at 1300 Elm street, this city, is one of the live institutions of the South, and its "T. O. P. Tips"—a bright, interesting house organ—is always full of interesting news matter. This concern controls the Edison jobbing interests in this territory, and is steadily expanding its business to meet its growing trade. New and impressive office quarters were recently occupied by President A. H. Curry and his capable staff. The retail department of this business, which is conducted under the title of The Phonograph Shop, Inc., is under the management of C. H. Mansfield.

There is nothing like responsibility for bringing out the latent power of men and women. And power increases by exercise just as brains or muscles do. So give workers responsibility and crowd them to their limit. In time they will have new limits.

It is to YOUR Interest

whether you are a

**Dealer
Jobber
or
Manufacturer**

to write us for the special proposition we have for you in

CABINETS

Equipped or Unequipped



Harponola

As an old established furniture house we have specialized on Cabinets. We have built them right and with individuality. Our facilities allow quantity production.

Write NOW so as to be protected for the Fall and Holiday Seasons.

Guaranteed and
Manufactured by

**The Celina
Furniture Co.**
CELINA, OHIO

Important Notice to Dealers

**Why Every Dealer Should Handle
The Highest Grade Phonograph
Steel Needle in the World.**

The WALL-KANE

First—Each WALL-KANE needle is guaranteed to play 10 records on any Phonograph, the tenth playing as clear as the first.

Second—Phonograph owners will always purchase WALL-KANE needles, since they eliminate the troublesome changing of needles after each record.

Third—WALL-KANE needles are scientifically prepared, and, by reason of special composition, are beneficial to the grooves of the record, thereby adding to its life.

Fourth—WALL-KANE needles minimize the usual scratching sound of the ordinary steel needle and greatly improve the clearness and tone of reproduction.

**TEST PROPOSED TO DEALERS TO
PROVE THE SUPERIORITY OF**

Wall-Kane Steel Needles

Take two standard disc records of the same selection, play one ten times with the same WALL-KANE loud needle; play the other record, the same selection, ten times, but with ten new, full-tone steel needles.

You will find that the record played ten times with the same WALL-KANE needle will sound clearer, will have less surface noise, and that under the magnifying glass the grooves of the record played ten times with the ten steel needles will seem to be more disturbed.

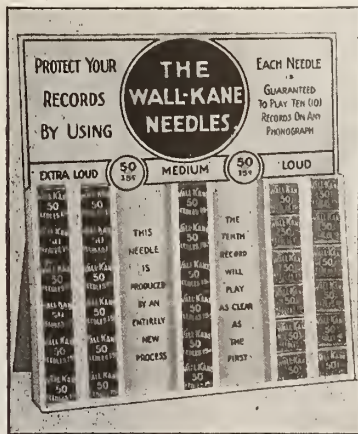

BEWARE OF IMITATIONS

Package of 50 WALL-KANE needles. Loud, Extra Loud and Medium, greater value than 500 ordinary steel needles, retails for 15c, cost the dealer 9½c.

JOBGING TERRITORIES OPEN
Progressive Phonographic Supply Co.
145 West 45th Street, New York



WILSONIAN PHONOGRAPH

Seven Superb New Models Ready for the Holiday Trade

The seven new models of the **Wilsonian** Phonograph have created a sensation wherever shown. They possess every good feature to be found in the most expensive makes, combined with remarkably moderate prices. To order now is to insure your having ample stocks on hand ready for a record breaking holiday business.

Wilsonian Features Appealing to Dealers

The **Wilsonian** sells on sight, giving a wonderfully quick turn over with no dead stock left on hand.

The **Wilsonian** sells at a generous profit to the dealer.

The **Wilsonian**, retailing at \$45.00 to \$165.00, affords a selection that insures every prospective customer finding just the style and price desired.

The **Wilsonian** keeps every customer permanently satisfied. Its superb quality guarantees that.



Wilsonian Features Appealing to Consumers

The **Wilsonian** plays all makes of disc records without it being necessary to make annoying changes.

The tone of the **Wilsonian** is superb in its clearness and felicity of reproduction. All vocal and instrumental selections are perfectly rendered.

The **Wilsonian** cabinet work, even in the least expensive model, is highly artistic and splendidly constructed.

The **Wilsonian** is absolutely guaranteed by both this firm and Wilson & Co.

The Wilsonian retails at \$45.00 to \$165.00

Dealers desiring to participate in the profits that will be made this season on the **Wilsonian** are invited to write to us regarding our dealer proposition.

Shipments are naturally uncertain. It is advisable to order as far in advance of your needs as possible in order to avoid disappointment in delivery.



25 West
45th Street
New York



701 North
Sangamon Street
Chicago

Wilson & Co. branches are in all principal cities including:

Pittsburg
Boston
Philadelphia
Baltimore
Salt Lake City

Buffalo
Detroit
Rochester
Cleveland
New Orleans

Denver
Omaha
Dallas
Atlanta
Los Angeles

Kansas City
Charleston
Memphis
Spokane
Minneapolis



DEALERS IN ST. LOUIS ARE BROADENING OUT THEIR LINES

Much Better Supply of Machines in Evidence—Good September Trade—Liberty Bond Campaign Under Way—Notable Brunswick Display—Silverstone Proud of Sale—New Aeolian Manager

St. Louis, Mo., October 7.—There appears to be a much better supply of talking machines in this market at present than there has been for several months. The conditions are so much changed that only a few dealers are complaining about not having supplies, and it does not appear that they are becoming used to a new merchandising situation, but rather that they are able to get more machines.

The exclusive dealer hardly is found any more. The older dealers all have their former lines, but nearly all of them have other lines as well. It would be a good deal like listing the advertisements in The Talking Machine World to enumerate the lines now handled. To one who recalls only a short time back when he could name all of the dealers in town readily and toll off the machines handled on his fingers, it is rather perplexing to see as many as four kinds displayed in one window, and that of a furniture company that formerly ignored the line entirely and to-day never advertises the fact that they sell talking machines.

During September trade was quite lively. More machines doubtless could have been sold, but the dealers are to a large extent selling only to persons who come to buy. The outside work is at a very low ebb. One reason for this is the low stocks that have been the rule, another is that the dealers as a whole are expecting the supply to get less before it gets more. The drop in trade is making quite a good turnover on the stocks carried and storage from now until the holidays is less expensive than prospect hunting. Apparently all dealers realize that under the present situation of the factories having to get permits for each shipment of machines they are likely to be cut off entirely at any time.

The talking machine dealers are entering into the plan of the retail merchants here of running a general advertisement urging early Christmas buying because of the restrictions placed upon retail trade by the Government. The plan is to spend about \$5,000 in this sort of ads, which will be entirely impersonal.

The talking machine dealers also are heavily interested in the plan now maturing to advertise "music in the home" by running in a local paper the Tremaine series of advertisements. It is said that this plan probably will succeed.

Early in October the prospects were that there would be rather a dull trade during the Liberty Bond drive. The chief reason for this is that all of the talking machine men and their salesmen have been enlisted as salesmen and are out on the streets selling bonds until the city is entirely canvassed. That will certainly take them one week from business and may take a part of the second week. But this is the least of their troubles, it appears, if you listen to them talk, and there is none of the spirit of making a sacrifice, but rather it is a spirit of willingness to help clear up a bad mess by hastening the end of the war. To name the men going into this work would be to run a roster of the merchants and their principal helpers. The stores are to be left in charge of the girls.

Manager Roos is beginning to feel well settled at the Columbia Co. branch here and is getting acquainted with the trade. He has built up the record stock, which he found somewhat depleted until he is filling series A orders about 90 per cent. The machines, he says, are the only worry. The retail trade is such that every one is willing to buy heavily, and when a car of machines comes in it usually brings about half enough machines to meet the orders on the books.

"The trade is exceedingly satisfactory from all angles," said Mr. Roos. "The demand is for the higher class machines and the two new models we are showing here are causing quite a commotion among our dealers and they feel that they could sell a factory output of them all by themselves."

C. R. Salmon, who left the sales force of the Columbia Co. to go to the army, has returned. He entered the army, but his feet gave out; and after spending some time in the hospital he was then given an honorable discharge. After he returned he was placed on the Illinois-Kentucky territory, but later Mr. Ivy, who came from New Orleans when the vacancy was made here, took that territory, putting Mr. Salmon back on his old run as city salesman.

"The Artophone Co. is not booking any wholesale orders at present," said R. H. Cone, Jr., "because we see no chance of delivery on all of the orders we now have. Our new models have brought such a demand for our instru-

(Continued on page 70)

Unique Incomparable is The Phono-Grand



Small; yet elegant and in perfect taste.

Moderate in price; yet musically unique and satisfying.

Combining a perfected talking machine of unusual excellence with a player-piano wholly novel and attractive in its compact beauty and tonal effectiveness, the *Phono-Grand* stands alone in its appeal to persons of all incomes and all requirements.

The *Phono-Grand* is the most salable musical instrument of the age. Everybody is delighted with it, everybody wants it. No other so perfectly hits off the taste of the day.

With the Q R S expression roll, the *Phono-Grand* becomes a perfect reproducing piano, small in bulk, indeed, but large in tone and expressive effects.

The *Phono-Grand* is the one best proposition for a big and quick seller this winter.

J.P. Seeburg Piano Co.

209 South State St. Chicago, Ill.
419 West Erie St.

A Fall and Holiday Winner



VANOPHONE MODEL B

The "Vanophone" Model "B" retails at **\$15** and guaranteed by a company of recognized prestige and standing.

The "Vanophone" has won success because of its excellent tone quality, constructional merit and artistic design.

The "Vanophone" is offered to the trade with the absolute assurance that it is warranted to give satisfaction and service.

IMMEDIATE DELIVERIES

THE GARFORD MFG. CO., Dept. B., Elyria, Ohio

ST. LOUIS TRADE BROADENING OUT

(Continued from page 69)

ment that we have had to shut off on orders and get busy on keeping our records as nearly clear as possible. With that we are behind. Our trouble in getting cabinets, which was acute some time ago, has been materially relieved."

The Brunswick branch here had a notable display during the first of the month and it attracted a good many window shoppers and not a few inquirers. The layout was a porch scene with the Brunswick girl leaning over her machine, with a reclining chair, table and other outdoor furniture about. The part that attracted the attention, however, was the records that covered the table and couch. They included all well-known makes of records and were so placed that the observer could not help noting the makes. Also there was a sign or two to call attention to them.

Mark Silverstone, who returned a few weeks ago from his extended trip to the Pacific Coast,

sold his first machine in more than six months on October 2. This is the way he tells about it:

"The woman and her husband came in looking for a \$100 machine and they had the cash. Of course I could offer them nothing less than \$120, but I showed that to them and, while they were looking, I told them that 'the talking machines got started wrong. Pianos at first cost \$1,000 up and to have a piano in your house gave you standing of being well to do, if not rich. The talking machines began at low price and have been built up to almost equal the piano in price, certainly as a musical instrument, but the people are slow to appreciate this change, but it is here.' Then I called their attention to a \$2,000 talking machine and we had a very pleasant chat while they listened to some numbers on a \$220 model. But they went out to see if they could not get something for their \$100 and after lunch came back and bought the \$220 machine, leaving their \$100 and pledging quick payments on the rest."

Mr. Silverstone says that he really enjoyed

this sale as much as he did a \$50 sale years ago, when that was considered a big one.

Mr. Silverstone says that now that he is back in the harness after his long vacation, he finds that Manager Goldberg and his helpers got along surprisingly well without him. Trade at present is better than the stocks of machines and receipts justify, he says, and he has declined to appoint any new dealers, although he has had several applications during the last month. Mr. Silverstone, however, has sent records to several jobbers during the last month, more than 4,000 going out at one time.

F. H. Brandt has been named manager of the Aeolian-Vocalion department at Aeolian Hall to succeed E. H. Guttenberger, who left September 15 to take new duties in Mobile. Mr. Brandt has been selling Vocalions, so there is little new in his new duties. He says that the last half of September, his first period as manager, was marked with excellent trade, but that October started a bit slowly, which he attributes to the Liberty Loan drive. Several of the Aeolian

The Perfectrola
REG. U.S. PAT. OFF.

Phonograph

A Good Line, a Big Seller, a Profit Maker.
More Than a Machine: A Musical Instrument.
Fully Equipped, No Extras to Buy.
Made by Experts.

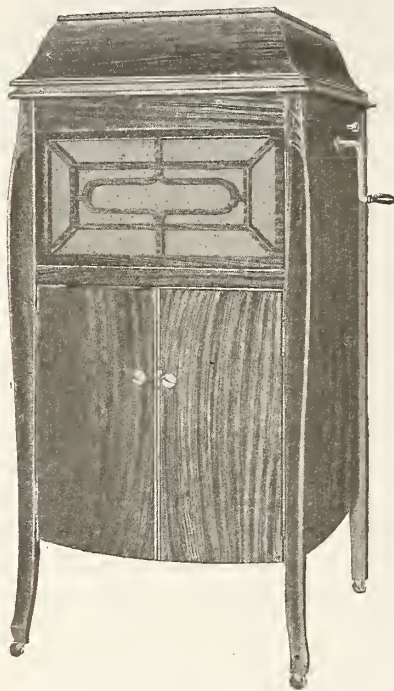

Model F—Retails \$100.00.



Model G—Retails \$125.00.

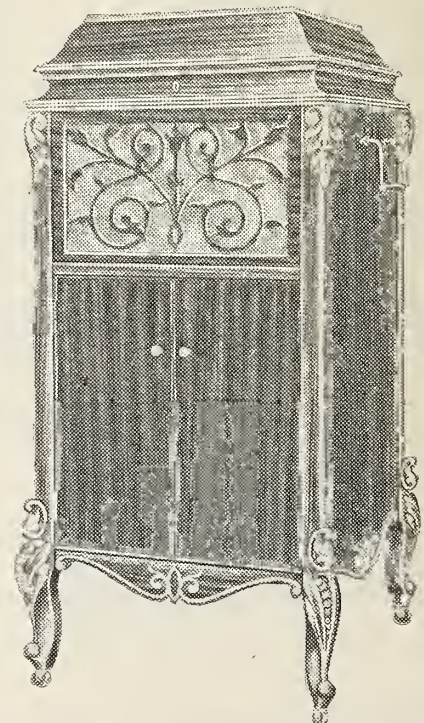

Model H—Retails \$190.00.

Cased in Mahogany
or Oak.

Triple Spring,
Worm Gear Motor. Tone Modifier,
Automatic Stop, Universal Sound Box.

Prices (Retail) range from \$25.00 to \$200.00.

Milwaukee Talking Machine Mfg. Co.

416-418 Fourth Street

Milwaukee, Wis.

Hall staff are members of the Liberty Loan Volunteer staff.

When Gus Haenschen, manager of the talking machine department of the Vandervoort Music Salon, was called to join the engineers' regiment, in which he enlisted several weeks ago, the department was placed under the management of C. E. Hammond, manager of the piano department, which now gives Mr. Hammond control of the entire activities of the Salon.

The record trade has been unusually good during the last month and it continued brisk during the start of the Liberty Loan drive. Some of the recent hits have run into amazingly heavy sales. "The Baby's Prayer at Twilight" was the first to run entirely out of bounds. Then several patriotic hits almost drove dealers to despair. Within the last few weeks it has been "Smiles." One dealer was saying—entirely without a smile—the other day that after being out of the record for several days he had been promised twenty-five when it was 2,000 that he wanted.

USOSKIN WINDOW SERVICE DISPLAY

Recently Introduced to the Trade—Wins High Compliments—Increase Line of Features

A large number of the windows of Victor dealers and distributors are trimmed this month with the new window display service originated by Ed. Usoskin, Inc., of 230 West Seventeenth street, New York City.

October marked the initial issue of this monthly service, and in accordance with their plan was entirely seasonal in its design. The theme followed was Autumn, which was well brought out in the golden browns and in the harvest of wheat design of the record easels. The large display cards featuring various numbers were produced along striking and novel lines.

The day after the October display was in the mails, Ed. Usoskin, Inc., were the recipients of many complimentary letters, both from dealers and jobbers.

In response to numerous requests this firm has added this month to their list of window display features, and in addition to their monthly Victor dealers' service, specially designed paper for floor and background panel covering. A new design will be issued each month in harmony with the display for that month. The October design is a deep blue background with fallen golden brown oak leaves, which adds

materially to the effectiveness of the October display. A descriptive circular has been prepared giving prices and full information of this added service.

Announcement has been made by the company of an increase in price effective November 1. Increased cost of materials, in addition to a change ordered by the Post Office Department regarding the mailing containers, has made this lightly increased charge an absolute necessity. Orders received up to that date will not be affected by the new rates.

FRANK DORIAN'S NEW POST

Well-Known Columbia Man Appointed Manager of Seattle Branch of Columbia Co.

George W. Hopkins, general sales manager of the Columbia Graphophone Co., New York, announced this week that Frank Dorian, formerly general manager of the company's Dictaphone department, had been appointed manager of the Seattle branch of the Columbia Graphophone Co. and will assume his new duties about November 1.



Frank Dorian

In a letter to the members of the sales staff Mr. Hopkins said: "This is Mr. Dorian's personal choice, and we feel that the company has very materially strengthened its hold on Pacific Coast business by Mr. Dorian's becoming manager. To say that our good will goes with him is hardly necessary. Activities on the Coast make it a particularly pleasing move to us, as big men are needed when a big job looms up. Mr. Williams, the present manager of Seattle, will be transferred to another important position, to be announced at a later date."

Frank Dorian is one of the best-known members of the Columbia Co.'s executive and sales organization, and during his many years' association with the company has won the esteem and friendship of the sales staff from coast to coast. He is thoroughly conversant with Columbia merchandising policies and plans, and the Seattle trade is to be congratulated upon Mr. Dorian's appointment as manager of that branch.

To-day's worry is the result of yesterday's neglect.

Reproducers

Mr. Manufacturer :

We are prepared to furnish a limited number of reproducers for immediate delivery.

Write us what tone arm you use and we shall be pleased to submit a sample ready for attaching: if, after trial, you do not pronounce our reproducer

THE VERY BEST IN QUALITY AND VOLUME YOU EVER LISTENED TO, we ask you to return the sample at our expense, and we thank you for the granting of this hearing.

Yours very truly,
FULTON-ALDEN CO.
Waukegan, Ill.

P. S.—Ready in 30 days: our new balanced cover-lift. Will not warp cover. Easiest to attach.

Ask for sample

FULTON-ALDEN CO
INC.
WAUKEGAN, ILLINOIS



It's a Pretty Good Idea to always keep in mind the fact that a



SCHUBERT PHONOGRAPH

will bear the closest inspection; its particular qualities warrant investigation, and hundreds of friends everywhere loudly extol its superiority.

SIX MODELS \$60.00 UP

SCHUBERT RECORDS

A \$30 investment starts you with complete, up-to-date list of Popular, Vocal and Instrumental selections; 20 to 30 new selections monthly; 10-Inch Double Disc. Write for details.



The BELL TALKING MACHINE CORPORATION

Offices and Show Rooms:
44 West 37th Street, New York

Factory:
85 Southern Boulevard, Bronx, New York

Export Department, 498-504 Broadway, New York, N. Y., E. U. A.
Smith-Woodward Piano Co., 1018 Capitol Ave., Houston, Tex., Local Distributor
Special Australian Representative, B. LESCHHAN, 350-2 Flinders Lane, Melbourne

Scotty has done his part



Scotty was only fifteen when war came to America. He spent his sixteenth birthday in the training area in France.

His greatest day was his last.

It fell to his lot to lie down with his beloved Sho-Sho gun at the head of a leafy, woodland path and see that not a German crossed it alive. Not one did, though thirty died in the trying before a sniper's bullet found Scotty's heart.

Now, as his comrades tell their tales of Scotty, their lips form this for his epitaph:

"He Was a Good Kid and He Died On His Gun"

Scotty did his part!!!!!!

ARE YOU DOING YOURS????

Remember—It is not what you've given, *but*

WHAT YOU STILL HAVE LEFT TO GIVE THAT COUNTS

Scotty gave all

New York Talking Machine Company
119 West Fortieth Street
NEW YORK

Chicago Talking Machine Company
12 North Michigan Avenue
CHICAGO

FROM OUR CHICAGO HEADQUARTERS

E. P. VAN HARLINGEN,
Manager

World Office
Republic Bldg., 209 South State St., Chicago
Telephone: Wabash 5774

CHICAGO, ILL., October 8.—Now that the big drive for Liberty Bonds is on, all thoughts of business, wholesale or retail, are a secondary consideration. L. C. Wiswell, manager of the Victor department of Lyon & Healy, is acting as chairman of the talking machine division of the Music Trades Liberty Loan committee, and is being supported by many of the best-known men in the Chicago trade. Nothing is being left undone by Mr. Wiswell or his men to put the Chicago trades quota over by a big margin.

With the wholesalers there is much activity and quite a bit of time is being given to pacifying dealers who are setting up a howl for more goods, primarily machines. The machine situation is becoming rather keen with the big jobbers, but the record situation is easing up somewhat. The monthly supplements are a little behind, but the standard selections are coming through in satisfactory amounts. No depression is felt at present among the trade in general, and the optimistic members are commenting upon the number of new concerns going into business here, and the merits of some of the new products. It can be easily seen, if one cares to devote some time to the subject, that there is no cause for depression, and it is likely that there will be very little of it, especially in the Chicago trade. Concerns backed with unlimited capital, who are prominent factors in other trades, have been going into the talking machine industry, and their chiefs, some of whom are "masters of industry" in other lines, are farsighted enough to see far beyond the length of their noses. They have staked their faith on coming events, and have no feeling of depression.

With the retail branch of the trade, especially in Chicago, it is not a case of salesmanship any more. It is merely a case of supplying the demand, and the demand at present is impossible to supply. This applies principally to records. As regards talking machines, Chicago's retail trade is not having a very great demand; in fact, the greatest demand coming in for talking machines is from the dealers in the outlying districts adjacent to Chicago. The newer concerns are helping in a great measure to supply this demand, not only in Illinois, but in all states; as great quantities of these new machines are being shipped to all parts of the country.

Death of William H. Guild

William H. Guild, who has represented the Edison Co. of Chicago throughout its Eastern territory for the past three years, died at his home in Wheaton, Ill., last week. Mr. Guild was well known to the trade and was one of the best liked of the wholesale talking machine travelers. He resigned a short time ago from the Edison Co. to take up the work of Y. M. C. A. secretary, and was stationed at Ft. Houston, Tex. Three weeks ago he returned to his home broken down in health, and shortly after his arrival died. He is survived by a widow, and a son aged fifteen.

An Interesting Window

The Wade Talking Machine Co. have placed in their window a Henry VIII period Grafonola which is attracting much attention. This machine is of antique wood, brightened in spots by the use of "polychrome," which gives it the effectiveness of woods turned out in the fifteenth century. The architecture of the instrument is true to form, with pointed arches, long lines, decorated posts and carved figures.

Honor Roll for Boys in Service

The Chicago Talking Machine Co. are having designed for them a beautiful honor roll for their boys in service. The roll is to be composed of metal, whereon the names will be placed. A colored star will also be placed in front of each name, which will tell a little story concerning the mentioned hero. For example, a gold star will be "He died in action," a red star, "Died of disease," etc. In the center of the tablet there will be a space whereon an extract from President Wilson's speech in honor of the boys in service will be placed. In all, the Chicago Talking Machine Co. will have thirty-eight names, honoring the boys of that company now in the service. There will be two made, one to be placed in the Chicago Talking Machine Co. office and the other to be placed in the New York Talking Machine Co. office.

Interesting Letter From Arnold Graham

One of the boys in the record department recently received a letter from Arnold Graham, who was formerly connected with the record department of the Chicago Talking Machine Co., telling of his experiences since being in the service. Private Graham tried to enlist in every branch of the U. S. service a year ago, but was

rejected, owing to an impediment in his speech. He waited a while and was one of the selects called to the examination board during the first draft, but again was rejected on account of his speech. But he had an idea he was going over to kill a few Huns, so he went down to the British recruiting station and was accepted and placed in the ranks of the famous Kilties. Five weeks from the day he was accepted he was at the front in France undergoing training. His letter, dated August 27, which was very interesting, is as follows:

"Dear Bill: I am back in England and my days in France are over. I was in that big push up Amiens way and got in the way of an iron foundry. My left leg is off just above the knee and a machine gun bullet went through my left arm, breaking it between the elbow and the shoulder, and I had an explosive bullet explode in the back part of my right leg just above the knee. Oh, I got mine, and then some.

"We went over the top two days in succession. The eighth of August we went over at 6 a. m. after a two-hour barrage, and it was like taking candy from a baby. We chased him all day and dug in at night. The next day at 1 p. m. we were ordered to take a grove of trees directly in front of us. To do this we had to cross an open space about 1,500 yards wide and this time he was prepared, for I'll swear that all the German machine guns in France opened on us when we started across that open space. You couldn't hear yourself think. Besides, his artillery opened up, too, but their range was poor. Some trucks came to our rescue from the right and the Fritzies came out of those trees by the scores, holding up their hands. Quite a few were game and died fighting.

"It was just as I started to enter the grove of trees that I got mine. I got the left arm one first and while I was lying on the ground I got the rest of my injuries, for, as I said, they didn't all surrender, and wounded men are great targets for them. It was a merry show for a while and I was lucky to come out at all. Let me hear from you, Bill. I am doing fine now. Yours, Graham."

Optimistic Over Outlook

W. G. Fricke, of the Lakeside Supply Co.,
(Continued on page 75)

THE "WADE" FIBRE NEEDLE CUTTER

assures "20 or more" *Original* New Points to each Fibre Needle

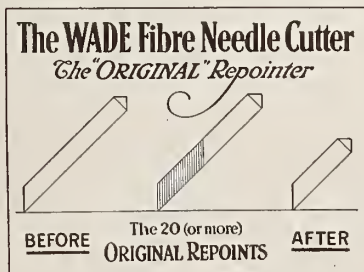

—and therefore is the most economical Fibre Needle Cutter on the market. You know the many advantages of using Fibre Needles—more natural reproduction; more tunes for one cent; no wear and tear on records, etc., etc., but, do not make the mistake of buying anything but the best Fibre Needle Cutter.

The Wade { is the oldest Fibre Needle Cutter on the market—
sells on demonstration—
never fails to give satisfaction—
is made in two styles—\$1.50 and \$2.00.

Usual trade discounts—Write for samples or Order from your regular Distributor

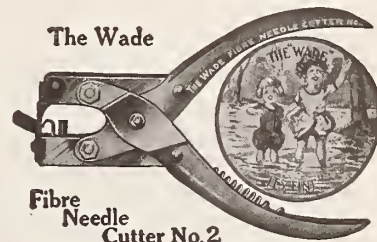

Fibre Needle Cutter No. 2
Price \$2.00

WADE & WADE, 3807 Lake Park Ave., Chicago, Ill.

DON'T SLIP!

STAY IN FIRST PLACE

¶ The indomitable national advertising of the VICTROLA has placed this instrument in a field of its own.

¶ Is this true in your home town?

¶ If not, write at once for Samples of Lyon & Healy advertising services.

They are used and indorsed by hundreds of Victor Dealers.



FREE THIS MONTH

With every order for one or more services we receive we shall send without charge six of these beautiful cut-outs. They are lithographed in full color, size 12x10, equipped with easel back. Just the thing for your window or counter.

Mail this coupon to-day. Mark (X) before service you wish.

Cut out and mail this coupon to-day.

Messrs. LYON & HEALY, Chicago:

Date

Gentlemen:—Please add our name to your subscribers' list for the services we have marked (X.)

.....
Sign your name here.

(X)

Your street address.

(X)

Your town and state here.

<input type="checkbox"/>	Victrola Newspaper Advertising Service consists of one Victrola advertisement each week, including matrix of the illustrations, proof sheet and copy. Price \$8.33 per month.	<input type="checkbox"/>	Victrola Record Fairy, 24-sheet Poster, \$2.30 each in lots of five or more. Specify quantity.
<input type="checkbox"/>	Victrola Newspaper Advertising Half Service consists of 26 advertisements per year, complete, at \$4.17 per month.	<input type="checkbox"/>	Victor Record and Knitting Bags. Made of Kraft paper with string handles, 12c each in lots of 100 or more. Specify quantity.
<input type="checkbox"/>	Victrola Art Window Posters. Printed in colors; four per month, i. e., two 14x22 inches in size; two 11x14 inches in size. They feature the new Records, \$1.25 per month.	<input type="checkbox"/>	Small Instruments Newspaper Advertising Service, thirty-six illustrations per year, \$4.17 per month.
<input type="checkbox"/>	Victrola Art Covers. Use them instead of envelopes for mailing the monthly Victor supplement; beautifully printed in colors. Tell us how many you need; we will quote prices.	<input type="checkbox"/>	Piano Newspaper Advertising Service. Forty-eight illustrations per year, free to Lyon & Healy dealers.
<input type="checkbox"/>	Victrola Galli-Curci, 24-sheet Posters. Lithographed in colors with name strip, \$2.30 each in lots of five or more. Specify quantity.	<input type="checkbox"/>	Soldier Song Books. Featuring the latest patriotic songs, 2c each; a splendid advertising novelty. Specify quantity.

LYON & HEALY

Victrola Distributors

CHICAGO, ILL.

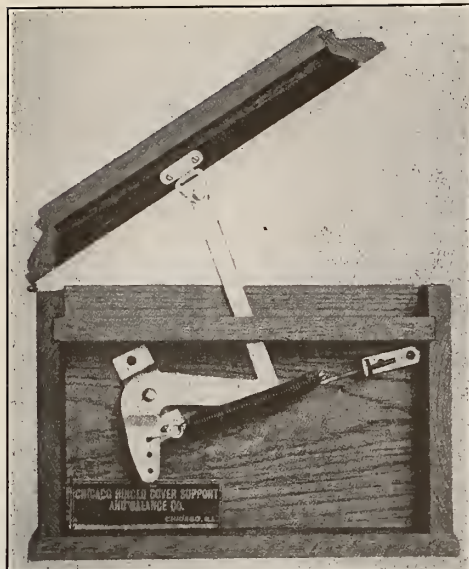

(Pat. Applied For) COVER BALANCE No. 1

Wherever You Go

You are sure to find a dealer somewhere selling a talking machine "without a kick." His business is growing steadily. Why? If you investigate the instruments he handles you will find they are rightly *Equipped*. That's what counts! *Equipment*. Look over your machine's *Equipment* a second time and then just remember that

The Chicago Cover Balance Number 1

is one equipment feature that builds a dealer's business. Can your dealers say they are selling talking machines "without a kick"? If not, write us at once and we will help put your machines on the market—"Kickless."

The cover is "PUT" and "STAYS PUT"

WE ALSO MANUFACTURE CONTINUOUS AND GRAND TOP HINGES

Chicago Hinged Cover Support and Balance Co. 2242-44 W. 69th Street CHICAGO, ILLINOIS

FROM OUR CHICAGO HEADQUARTERS—(Continued from page 73)

manufacturers and jobbers of motors, tone arms and general phonograph supplies, reports most cheerfully as to business present and prospective. Western business, says Mr. Fricke, is opening up most expansively, and he is getting inquiries from the Pacific Coast also in good numbers. The Lakeside Supply Co. has at the moment an excellent stock of motors, tone arms and sound boxes and is ready to supply the trade in all these parts without delay. This includes also hinges, hardware, etc.

Negotiations have been opened with a wood-working plant of high grade, says Mr. Fricke, whereby it will be possible, if the deal goes through, to turn out complete cabinet machines, Lakeside equipped throughout, at the rate of 150 per week. Meanwhile Mr. Fricke has closed a nice order for accessories of all sorts with Mr. Valabhdas Runchordas, of Bombay, India, one of the leading talking machine manufacturers and dealers of the Orient, who is now on an extended business trip through the United States. During his stay in Chicago Mr. Runchordas was a frequent visitor to the offices of The Talking Machine World.

Working Hard on Liberty Loan Campaign

Otto Schulz, president of the Magnola Talking Machine Co., has been, as might be expected by those who know him, extremely active during the whole of the great campaign for the Fourth Liberty Loan. He is chairman of the Seventeenth Ward Liberty Loan committee and has been giving up his time and energy to canvassing. At the end of the third day from the beginning of the drive the Seventeenth Ward of Chicago had subscribed 31 per cent., or nearly one-third of its quota. This ward is industrially populated, mainly by workers in factories, and contains a very large foreign population, mainly Polish, Slovak and Russian. This record on the part of a poor neighborhood is one which naturally is the source of much pride and gratifica-

tion to Mr. Schulz and his hard-working associates on the Loan committee. The unselfish work of all the Magnola officials, in fact, has been a feature of the drive in this section of the city. Vice-Presidents Bassett and Wolff, Wholesale Traveler Hewitt and other Magnola men have been prominent in the work. Up to the time of writing every adult male employe in the Magnola factory had subscribed for at least one Liberty Bond. The service flag now holds more than fifty stars.

The Caruso Concert

Music lovers of Chicago are to be given a treat Sunday, October 27, when for the first time in several years Enrico Caruso, the great Italian tenor, will be heard in concert at the Auditorium Theatre, Chicago. The Caruso concert will be an entirely patriotic affair, staged in the behalf of the Allied War Board, and part of the receipts will be turned over to the Italian Relief Committee and part to the U. S. Relief Committee. As this will be one of the biggest events in musical circles of Chicago that has been pulled off for a long time, it would be a good idea for local dealers to push their Caruso records in advance of the concert.

Miss Maroney on Way to Recovery

Miss Mary Maroney, in charge of the correspondence division of the Phonograph Co., was taken ill on Monday of this week. Latest reports issued by the physician in charge state that Miss Maroney is well on the way to recovery and may be able to return to her duties in a few days.

Brunswick Man an Ace

Among the thirty Americans recently mentioned as having brought down enemy planes one name in particular was that of Lieut. Reed G. Landis, son of Judge Kenesaw Mountain Landis, of the U. S. District Court. Lieutenant Landis, who was formerly in charge of the advertising department of the Brunswick-Balke-

Collender Co., but is now flying with the British air forces, was third on the list with ten victories to his credit.

Those in the trade who knew Lieutenant Landis were not surprised at the news of his victories, as they know the caliber of the illustrious family from which he comes. As the trade will remember, his father, Judge Landis, was the man who made the country sit up and take notice several years ago by fining the Standard Oil Co. twenty-nine million dollars. Those who know Lieutenant Landis know that he is a chip of the old block who isn't going to let his dad get ahead of him as an inflictor of penalties if he can help it.

Automatic Container Co. News

Chas. E. Osborne, president of the Royal Talking Machine Co., has been granted a license by F. P. Read, of the Automatic Container Co., to manufacture and sell Automatic Record Container cabinets on a royalty basis. For the purpose of carrying out this project the Royal Talking Machine Co. has established a new and completely equipped plant at 455 West Huron street, where the cabinets will be manufactured.

Under the old regime the Automatic Container cabinets were manufactured in three factories, two in Chicago and one in Buffalo; but according to the plans of the new company the cabinets will be manufactured at the new Chicago plant exclusively.

Mr. Read, the inventor of the Automatic Container and founder of the old company, has purchased land near Mt. Vernon, Ill., and is forming a stock company to recover a flinty rock, known as "Novaculite." The new company, when formed, will use this rock, which, by the way, embodies a natural cement for road building purposes, and it is estimated that there are approximately thirty million cubic

(Continued on page 77)

TRANSFER NAME-PLATES

We make the Transfer Name-Plates and Trade-Marks for the largest talking machine manufacturers in this country and for dealers in every state.

YOUR NAME, Mr. Dealer, on every machine brings the owner back to you for records and his friends to you for a machine.

Samples, Suggestions and Sketches Furnished Free

THE MEYERCORD COMPANY, CHICAGO

Largest Manufacturers of **DECALCOMANIA** Transfer Name-Plates

Two Great Selling Features Every Brunswick Dealer Appreciates

1

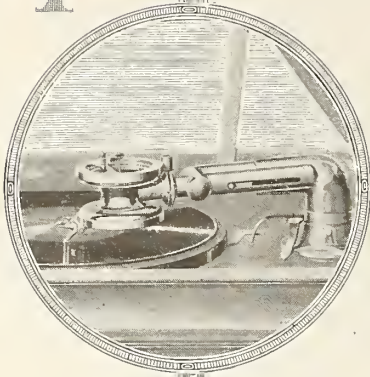

The
Ultona—

a unique feature of The Brunswick Method of Reproduction. Now you can play all makes of records at their best.

THE Brunswick Method of Reproduction has brought about an increased volume of sales. Dealers everywhere join in praising this great idea.

Most dealers realize the drawbacks to old methods of reproduction, and the public, in becoming acquainted with The Brunswick Method, is losing interest in yesterday's standards.

The House of Brunswick is educating the music-loving public to make comparisons. In its advertising in national publications The House of Brunswick is stating compelling facts—which few purchasers care to ignore.

The current advertising campaign spotlights two

features of The Brunswick Method of Reproduction: [1] The Ultona and [2] The Brunswick Amplifier.

A description of the Ultona is enough to make the average buyer anxious to see this new all-record player.

In speaking of The Brunswick Tone Amplifier, we state how The Brunswick attains superior reproduction by complying with acoustic laws, and how we avoid old conceptions.

By studying our advertising, you will note that it is pure selling copy, the exact arguments you and your salespeople can use to great advantage. It is straight from the shoulder, and presents compelling REASONS WHY.



The **Brunswick**
ALL PHONOGRAPHS IN ONE

2

This "super-phonograph," as hundreds of Brunswick Dealers will attest, has won high rank as a profit and friend-maker. And its popularity is ever increasing.

We are proud of its reception and of the fine dealer connections it has brought to The House of Brunswick. We have placed our faith and

our resources behind this phonograph and we know that an even greater future is attainable.

More and more The Brunswick is winning friends—everyone who hears it recognizes its worth. We intend to increase this appreciation of The Brunswick—and every Brunswick Dealer will profit thereby.



The
Brunswick
Amplifier

a new idea in tone reproduction, departing from old-time crudities. Tones hitherto lost are now brought out in rich clarity.

The Brunswick-Balke-Collender Company

Branch Houses in Principal
Cities of United States,
Mexico and Canada

General Offices:
Chicago and New York

Canadian Distributors
Musical Merchandise Sales Co.
Excelsior Life Building
Toronto

FROM OUR CHICAGO HEADQUARTERS—(Continued from page 75)

yards of "Novaculite" to be reclaimed from the land purchased by Mr. Read.

A. L. Spring on Tour

A. L. Spring, manager of both the wholesale and retail talking machine departments of Thos. E. Wilson & Co., is planning the itinerary of a three weeks' trip through the South and West. Immediately upon his return Mr. Spring contemplates a trip to New York and will be gone about two weeks.

"We have been getting quite a number of letters from our dealers recently, commenting upon the new model talking machines that we have added to our line," stated Mr. Spring. "Seven styles are now being made at our factory at retail prices ranging from \$45 to \$165. Thos. E. Wilson & Co. intend to enter the talking machine trade as manufacturers on a larger scale than ever before. The parent company, Wilson & Co., as is well known, is one of the largest packing houses in the world, with a capitalization of forty million dollars, and our resources are unlimited. In the retail

department, at 420 South Wabash avenue, we have made quite a change within the last few weeks, having moved this department from the second floor to the basement, where we have installed quite a number of new booths and have also increased the size of our record department for Paramount records, for which we are jobbers."

Anent Sergeant-Major Vorkeller

One of the young men formerly of the talking machine industry who is doing his share in the Liberty Loan is Sergeant-Major H. P. Vorkeller, in charge of the Base Hospital Band of Camp Grant, who, prior to his induction into the National Army, was connected with the retail Victor department of Lyon & Healy. Some time ago with other selects he was sent to Camp Grant for military training, but was placed in the Base Hospital unit instead of the infantry. While still connected with the retail forces of Lyon & Healy Sergeant-Major Vorkeller made a national reputation for himself as a saxophonist. He is said to be one of the greatest

saxophone artists in the country and a master of classic music. It didn't take long for the authorities at Camp Grant to find this out, so they put him through a grueling examination in musical matters, through which he came with flying colors. He was then ordered to select men from the other members of the Base Hospital and form a band, with the rank of assistant band leader. He started in on thirty-six buck privates and in a short while had them so that they could hold their instruments to their lips. He was then promoted to sergeant, and after some further work had his "bucks" so that they could give a fairly good account of themselves. The band is now well up on classical numbers, especially, and is considered very good on military music. His last promotion prior to being sent to Chicago with the band to take part in the Liberty Loan was to sergeant-major.

Activity in the Northwest

"There is much activity throughout the (Continued on page 79)

VITANOLA TALKING MACHINE CO. TO EXPAND ITS PLANT

Secures Tract of Land With Recently Purchased Factory Building Upon Which Six-Story Addition Will Be Erected—Modern Equipment Throughout—A Story of Quick Success

CHICAGO, ILL., October 9.—The Vitanola Talking Machine Co., of this city, which recently closed a deal for the purchase of the plant of the Lincoln Sash & Door Co. at Fifty-second avenue and Nineteenth street, near the Western Electric Co., also took over in connection therewith a three-acre tract of land on which they will erect, as soon as war conditions permit, a modernly equipped new six-story factory building. The present structures on the property

four-story cabinet factory is planned to accommodate also the assembling department and the executive offices now located in the spacious Vitanola Building at 501-509 West Thirty-fifth street.

Within a few years the Vitanola Talking Machine Co. has grown from almost nothing to one of the leaders in its field. All the trade knows the Vitanola as an instrument that contains everything desirable, but not one thing superfluous. Its success is not based upon a feature; instead the Vitanola is a perfect whole, built of parts each constructed to fit in with the others. And not only musically, but in every way the Vitanola is a work of art.

The cabinet designs of the seven 1918 models are the envy of many less fortunate manufacturers, and the seven 1919 models, which will be added to the Vitanola line, represent the very highest achievement of the woodworkers' craft. An idea of the exquisite beauty of the coming models may be obtained from the illustrations in these columns of the unique art model, No. 17, and two of the new cabinet models. Like all products of the Vitanola organization, the new models conform with the latest discoveries in the science of acoustics.

Always alert to the war demands of the Government, the Vitanola Co. also watches carefully, and protects to the full extent of its power, the interests of the dealer. For the Government's very fair decisions in matters pertaining to the industry, credit is due in a great measure to M. C. Schiff, who was untiring in his efforts to lay before the proper authorities the truth concerning the wartime necessity of talking machines, and the none too

favorable conditions which the retailer must contend with.

Perhaps it is simply a working out of the old proverb, "Like begets like," that accounts for the loyalty of the Vitanola concern's many customers, the list of which includes some of the country's highest grade, best rated firms.

The spirit of co-operation and fair dealing, which has won for the company the esteem of the trade, is not confined to any one direction, but finds expression in all of its activities, including the treatment of its employes, all of whom feel a personal interest in the welfare of the company and the quality of its product.

Approved sales helps of all kinds are the deal-



Vitanola, Style 12

Vitanola, Style 10

include a large two-story factory with dry kilns and storage sheds, and the entire property is served by a switch track with capacity for twenty-five cars.

While the present building will permit of considerably increased output, it cannot adequately meet the excess demand for Vitanolas, and a



Vitanola, Style 17

er's for the asking. Now the company is going to make Vitanola sales still easier for the dealer by a billboard campaign, for which thousands of dollars have been appropriated.

To M. C. Schiff and Samuel S. Schiff, who already devote long hours and intense effort to the business, will fall additional burdens and responsibilities with the expected early departure of the junior member, Jeffrey B. Schiff, who has enlisted in the Naval Officers' Training School, and whose many friends will wish him God-speed.

UNIVERSAL TONE ARM

**NO SPRINGS
NOR WEIGHTS
TO ADJUST**

**MADE IN
FOUR
LENGTHS**

Patent Applied For

Talking machine manufacturers should anticipate their tone arm needs early to insure prompt delivery. The demand for phonographs this Fall will be very large, and it is the manufacturer who places his order early that will be given the benefit of Empire service. Get in touch with us at once and secure our quantity prices on this splendid equipment.

Address all inquiries to Chicago Office

**PLAYS ALL
MAKES
OF RECORDS
PERFECTLY**

**WRITE
US FOR
PRICES**

THE EMPIRE PHONO PARTS COMPANY

Sales Office: 425 SO. WABASH AVE., CHICAGO, ILL.
Factory: 1100-1108 W. 9th STREET, CLEVELAND, OHIO

PHONOGRAPH DEALERS ENDORSE HIAWATHA QUALITY

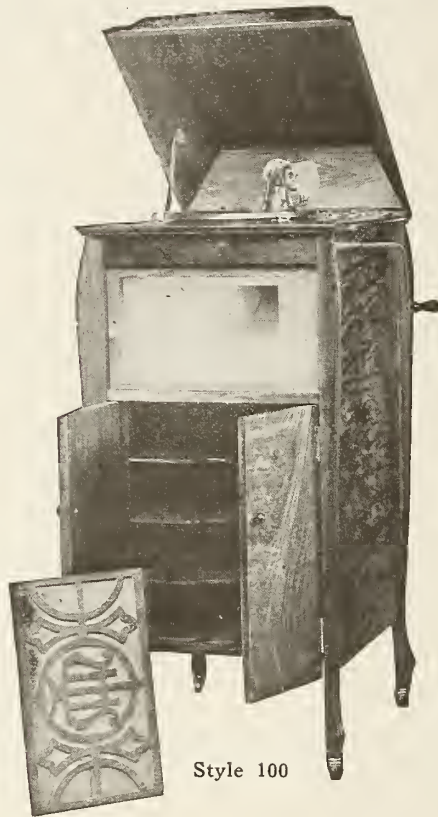

Style 100

Hiawatha Phonographs Repeat

Any phonograph you sell that will bring you repeat business is honest merchandise.

Dealers endorse the Hiawatha by their repeat business, service and satisfaction.

They can sell Hiawatha Phonographs with every confidence that they will be satisfactory in tone, finish and equipment.

FIVE HIAWATHA MODELS
\$50, \$75, \$95, \$125 and \$175

IMMEDIATE DELIVERY



Hiawatha Phonograph Company

209 South State Street
CHICAGO, ILL.

FROM OUR CHICAGO HEADQUARTERS—(Continued from page 77)

Northwest," said Paul L. Baerwald, of the Otto Heineman Phonograph Supply Co., "and a great deal more business is being done throughout that territory than here in Chicago. I am speaking of the retail trade only, and not of the wholesale. A large demand has sprung up for our OkeH records, and from present indications these are destined to become quite popular. Our policy is to place these records on the market through the jobbers only at present, and we are in a position to take care of our trade up until the first of January. After that, as is well known, everything depends upon the decision of the war board. Collections have been exceptionally good, and we are not having any trouble whatsoever from this source."

Mr. Baerwald is managing the Chicago headquarters of the Otto Heineman Co. until the return of Manager S. A. Ribolla, the first of the week, the latter having gone to New York for a conference with the officials of the company.

Shell-O-Phone Ready for Market

The Shell-O-Phone Talking Machine Co., whose offices are in the North American Building, are now ready for the market with their machine. They have been working on it for a year and now announce that they have perfected it, have conquered all acoustic problems connected with it, and are ready to consider propositions for agencies. The one feature of the Shell-O-Phone is the fact that the horn of each machine is a large conch-shell, captured on the beach of one or another South Sea Island. It is placed in the back of the instrument and connected to the "sound arm." In the words of the company's literature, "the tones reflect and expand as though from the human throat or actual musical instrument itself." The Chicago representative of The World was present at a demonstration the other day and believes the Shell-O-Phone to be a machine of excellent tone. The cases are of massive design, and the cabinet work and finish is good. The concert grand size is recommended for use in large halls, hotels, clubs and places where great volume of music is essential. The volume of tone on all sizes is naturally loud, but can be reduced at will by the use of the proper needle.

Record Knitting Bags

In order to assist their women patrons in carrying records home the retail record department of Lyon & Healy is packing records purchased by women in brown tough paper bags. These bags have a tape handle and brass fastener. They are similar to the regulation knitting bags that women are carrying nowadays, and can be used as such. The idea of these bags was conceived by L. C. Wiswell, manager of Lyon & Healy's Victor department. They have been received with much favor by women who purchase their records at Lyon & Healy's, as they enable one to carry records through the city with a minimum danger of breakage. There is a pretty picture by Nancy Beatty, the talented artist, printed on one side of the bag, while the other side is devoted to the name and address of Lyon & Healy.

Such a demand has been created in Chicago for these bags that the service department of Lyon & Healy thought it would be a good idea to offer them to the different retail houses they serve throughout the country. For this purpose a large number have been made up. The Victor record and knitting bags are made of Kraft paper with handles and are offered to the retail trade for 12 cents each in lots of one hundred or more.

Empire Records Take Well

Quite a number of new agencies have been established within the past month to handle the new Empire hill and dale cut records, which were placed upon the market for the first time last month. These new records are known as the Black-Faced Empire and are ten-inch double-disc hill and dale cut and can be played with steel needles. The surface noise has been reduced to a minimum and records can be played on any universal talking machine. The November releases consist of a library of fifteen

numbers, embracing popular and standard selections. In connection with these records the Empire Co. has had prepared for them some exceptionally handsome hangers heralding the latest releases. These are printed in colors and may be recognized by the new Empire record cut shown elsewhere in this issue. This supplement is a very artistic example of the highest grade of print craft and a goodly quantity is supplied with all orders.

The Empire talking machine is also coming up very strong and twelve Empire models retailing from \$32.50 to \$500 are having a very good demand throughout the Central West and Eastern territories, especially Pennsylvania. One of the most popular sellers in the Empire line is the Empire portable machine, a very compact and durable little instrument that plays all makes of records. John H. Steinmetz, president of the company, also stated that the demand for their new Empire art model, which was announced some time ago, has proven greater than his anticipation, and he is urging

his dealers to place their orders for these instruments early, so as to be sure to have them on the floor in time for the holiday trade.

Brown Goes Over the Top

The R. M. Brown Music House, 3018 East Ninety-first street, South Chicago, Ill., dealers in Victor, Columbia and Kimball machines, have gone over the top for the Fourth Liberty Loan, having subscribed \$1,250 to the same. This subscription represents an investment from every member of the staff, and was secured by J. V. Sill, of the talking machine division of the Allied Music Trades. The Brown concern are Kimball dealers, handling the pianos and players made by the W. W. Kimball Co. in addition to the lines of talking machines mentioned above.

Loyal to Established Dealers

H. B. Bibb, sales manager of the phonograph division of the Brunswick-Balke-Collender Co., announces that while they have been able to care for their established trade very nicely at

(Continued on page 80)

Here's Why the Talking Machine Business Is So Good

HOME has taken on a new aspect since we have entered this war. It means more to the father and mother who have boys fighting—it means more to the wife whose husband has gone away, and so on. The result is that families are spending more time in their homes.



8 Models
\$27.50 to \$250.00



Trade Mark Registered

This has its effect on retail talking machine sales. Many families who have heretofore gone outside of their homes for amusement are finding that the talking machine with its wide range of music is bringing amusement into the home.

So now is the time to push your talking machine sales—now is the time to order (for Holiday business) the machine hundreds of dealers like yourself are making from \$1,000 to \$10,000 net profit on—the

VITANOLA

Certainly there is no time like the present for making real cash money out of the Vitanolas, for lightless nights, gasolineless Sundays, and possibly fuelless days mean more talking machine sales. If you are having trouble getting standard goods you ordinarily profit on and are losing dollars because of it, order some Vitanolas now, they'll more than make up the loss in profits.

The Vitonola will make money and friends for you. It's the machine that satisfies—the machine people buy when they see and hear it. In order to insure quick delivery order now. Don't think—act.

VITANOLA TALKING MACHINE CO.
501-509 W. 35th Street - - - - CHICAGO, ILL.

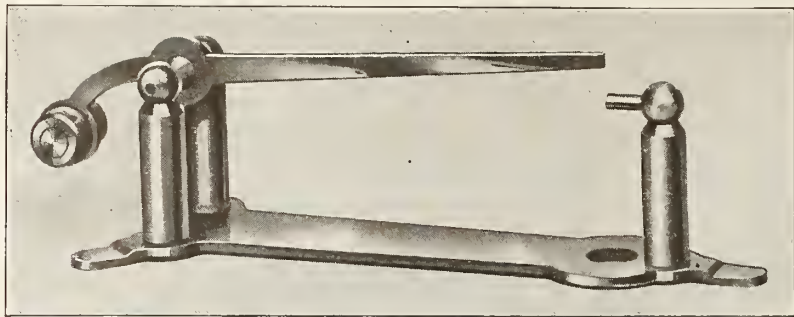

ROTOMETER—ACTUAL SIZE

PHONOGRAPH HARDWARE, MOTORS AND TONE ARMS, ETC.

WE CAN SUPPLY A LIMITED NUMBER OF CUSTOMERS ONLY. ACT QUICKLY.

Send for free sample of our door knob, seven-eighths inch diameter.

Telephone, Harrison 3840

LAKESIDE SUPPLY CO., Inc. 202 So. Clark Street, CHICAGO, ILL.

FROM OUR CHICAGO HEADQUARTERS—(Continued from page 79)

the present time, owing to the shortage of labor and other matters and a desire to conserve the interests of their loyal dealers, they are not adding any new accounts at the present time.

Brunswick Quartet

The group of handsome gentlemen shown in the accompanying photograph includes, reading



Group of Brunswick Men

left to right: A. J. Kendrick, general supervisor of branches of the phonograph department

of the Brunswick-Balke-Collender Co.; H. B. Bibb, sales manager of phonograph division; R. J. Waters, former Brunswick district manager; A. B. Libbett, in charge of Chicago city sales.

Mr. Waters was on a furlough from Camp Pike, Arkansas. He was then taking the Reserve Officers' Training Course. He has since gotten his lieutenantcy and is now training a bunch of rookies.

Wurlitzer Co. Changes

There has been a change in managerial positions at Wurlitzer's within the past week or so. L. E. Noble, formerly manager of the wholesale Victor department, has been transferred to new duty as manager of the retail department. F. A. Siemon, who formerly managed this department, has been placed in charge of the automatic department at 615 Wabash avenue, having succeeded Manager Herman, of this department, who is now on the Coast in the interests of the company.

Hans Schloessing, who formerly covered the Chicago territory for the Wurlitzer wholesale Victor department, was placed in the position vacated by Mr. Noble.

Wallace Brown, proprietor of the Brunswick Shop of Detroit, and Geo. S. Standke, manager Brunswick Shop, Indianapolis, were recent visitors.

ADJUSTING BUSINESS TO THE WAR

Interesting and Timely Chat on This Subject With J. C. Roush, Secretary of the National Association of Talking Machine Jobbers

PITTSBURGH, PA., October 10.—"The adjustment of business to war conditions," says J. C. Roush, secretary of the National Association of Talking Machine Jobbers, to The World representative, "is to-day a patriotic duty which no man, in whatever business engaged, can escape.

"The curtailment of everything which affects the business of a talking machine retailer has reached a point where it is absolutely necessary that he immediately check up his present stocks, determine in every way possible what he may expect in the way of merchandise from his wholesalers, and then make his expense budget conform rigidly to this basis.

"An overhead expense which seemed economical when goods were plentiful is likely to be grossly extravagant now. A sales force which was hardly adequate when a dealer's floor was crowded with machines and his shelves filled with record 'hits' is now probably entirely too large. Then, too, it should be remembered that the Christmas buying season is to be spread over a longer period this year, that hours of business are not to be increased, and that sales forces are not to be augmented. All of which makes it the easier for the dealer to plan a very conservative program as regards his selling force and all other overhead expenses.

"Please don't misunderstand me. I am not advising any general retrenchment, any relaxation of selling aggressiveness, any curtailment of advertising. The continuation of such efforts is essential to the maintenance of a dealer's standing, his prestige, his good will.

"But I do urge cutting out the waste. Trim every useless expense to the bone. Search out the little and the big leaks and plug them up tight. Most of us believed we were working on an economical basis already, but we were surprised at the useless expenditures we found

Repair Parts

For All and Every Motor That Was Ever Manufactured

We can supply any part. The largest and most complete assortment of repair parts—in the United States—on hand, for old, obsolete and present-day motors. If your order cannot be filled from stock, we will make it up special.

Special prices on main springs, governor springs, micas, etc., in quantity lots.

Steel needles on hand for immediate delivery in loud, medium and soft tones.

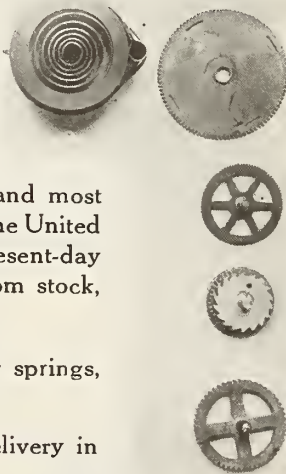
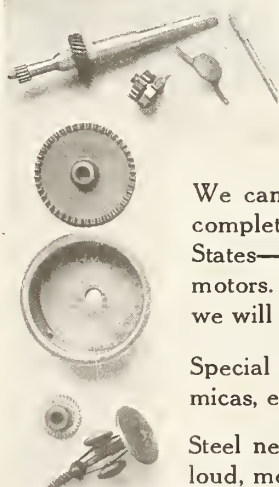

INCORPORATED UNDER THE LAWS OF ILLINOIS

Consolidated Talking Machine Co.
Manufacturers of

SUCCESSORS TO Standard Talking Machine Co. United Talking Machine Co. Harmony Talking Machine Co. O'Neill-James Co. Arctina Co.

High Grade Talking Machines, Disc Records, Talking Machine Supplies, Etc.

227 W. Lake Street, CHICAGO, ILL.



TRADE MARK "CONSOLA" CABLE ADDRESS "CONSOLA"

We Make Stamped Steel

SOUND-BOXES

in View of Shortage in Die-Casting Market

Chicago Recording Scale Co.
WAUKEGAN ILLINOIS

to trim when studying them in the light of curtailed shipments of merchandise.

"Big business is just around the corner. When the war ends talking machine dealers are coming into their own. They are to see the biggest demand for instruments and records in the trade's annals. But the wise, far-sighted dealer will so finance the lean period between now and the signing of peace that the expanding trade condition will find him ready and waiting to take advantage of them.

"Tell your readers that every business needs the closest kind of scrutiny during the months ahead—study of expenses, study of merchandise market, study of records "in stock" with distributors.

"Eliminate the sending out of records on approval, explaining to your customers in doing so that this is really a service to them, as no one wishes to place in his record library used records. Discontinue useless and extravagant deliveries of records, training your clerks to

explain the necessity of such economies at this time. Stiffen up instalment terms on machines, limiting payments to cover periods not exceeding six months. Sell records only on a cash basis.

"Merchandise to-day should be sold on terms that will enable a dealer to meet his bills promptly. Revise mailing lists, cutting out all useless expense of clerical work in mailing, postage, etc. A dealer should realize right now that all the taxes and increased costs which he must expect cannot be met by any increase in price which may be effected.

"The average dealer who is doing these things, and who is maintaining his relations with his trade, may have the assurance that he is working towards a big business expansion in the days now not so far distant."

Conlin's Talking Machine Shop, Chicago, Ill., is now located in new quarters at 2322 West Madison street, that city.

MANUFACTURE THE "STERLING"

The Compacto Phonograph Co. has succeeded the Sterling Phonograph Co., and is now manufacturing a complete line of "Sterling" phonographs. This line has been on the market for several years, and has won considerable success throughout the country. The executive offices of the company are located at 31 East Twelfth street, and the factory at 21 East Eighth street, New York. A. Sundheimer, well known in the phonograph industry, is general manager of the company and in charge of manufacturing and distribution. It is planned to manufacture a line of eight models, all equipped with a universal tone arm, and with guaranteed parts throughout. Arrangements are now being made for an effective campaign to reach the trade and the public.

Sell all the records you can, and then put some of your surplus in Liberty Bonds.



10-inch Double-face Records

Let us send you an assortment of the new Empire records. There are 15 numbers in the November release and you will find each one will sell rapidly.



Retail at 85c.

Empire records are hill-and-dale cut, and can be played with a steel needle. No surface noise, no vibration or scratching. Can be played on any universal talking machine.

Mr. Dealer—Take Our Agency—Now!

We say "now" because this is the proper time to put in the Empire line. It may be hard for you to get Talking Machines before many weeks are past, and the dealer who takes on the Empire agency now will be assured of prompt deliveries in the future. There's real profit made in Empires, and satisfied customers as well. Empire records and machines offer an unbeatable combination.

We Will Send You Our Agency Offer

Do not let another day pass without writing for our dealer proposition. We offer you a splendid line of machines at prices to fit the size of every purse. The very best material and the utmost care are used in constructing Empire machines. The wonderful Empire tone arm plays all makes of disc records perfectly.

12 Models Retailing From \$32.50 to \$500

One of the most popular sellers in the Empire line is the Empire portable. Very compact and durable and plays all makes of records. Our portable folder will explain it thoroughly. Write for it.



Model B.



Showing the Empire Portable set up ready for operation

EMPIRE TALKING MACHINE CO.

John H. Steinmetz, President

429 South Wabash Avenue, Chicago, Ill.

LINERPHONE

A Success, not an Experiment!

*Handsome
Fully Equipped
Reproduction Faultless*



Linerphone Model 300

The Linerphone Line includes 7 styles retailing from \$75.00 to \$150.00: Mahogany and Oak

*Write for Information
Prices Sent On Request*

**LINERPHONE
TALKING MACHINE CO.**

1801 Nebraska Avenue
Chicago

FULTON-ALDEN CO.'S NEW HOME

Secure New Manufacturing Quarters in Milwaukee—Controls Metal Specialties Co.

WAUKEGAN, ILL., October 10.—The Fulton-Alden Co., of this city, well known to the talking machine trade as producers of the Fulton phonograph, has completed an important new deal in-



New Plant of Fulton-Alden Co.

volving the removal of its entire plant to a much larger site in Milwaukee, Wis., and the opening of a new era in the company's business.

For some time past it has been the desire of the company's officers to turn out a phonograph entirely Fulton-made, including motor, reproducers, etc., complete. They have now consummated a deal whereby they acquire control of the Metal Specialties Co., of Benton Harbor, Mich., together with the services of W. R. Everett, who has superintended the manufacturing department of this concern. The Metal Specialties Co. plant has been devoted to the manufacture of talking machine motors, tone arms, and parts, and Mr. Everett has a national reputation as a designer and maker of such parts, especially motors.

The machinery and fixtures of the Benton Harbor plant, together with the equipment of the present Fulton-Alden factory at Waukegan, are being transferred to a new building recently purchased in Milwaukee, occupying three stories



Part of Finishing Plant

and covering an irregular plot of ground 175 feet by 300 feet. The building is fireproof, steam heated, equipped with steam power and located on a siding of the C. M. & St. P. railway.

Through this combination of interests the

Equip Your Phonographs With Perfect Automatic Brakes

Samples \$1.00 Each
Cash with order

State make of tone arm used

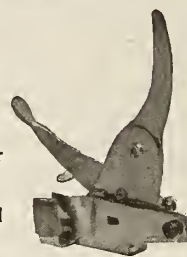

Also made with long brake shoe for 1 inch offset

Patented Aug. 28, '17

Simple construction and easily attached. Made in four styles to fit any make of tone arm.

Write for attractive quantity price

PERFECT AUTOMATIC BRAKE CO.
Room 400, 425 S. Wabash Ave., Chicago

Fulton-Alden Co. has, of course, been able greatly to increase its output, and it is expected that many improvements in the character of Fulton service will flow therefrom. There is a very distinct advantage in selling a machine wholly made under one roof in all its parts, while at the same time the company is acquiring a motor, among other things, of definite and well-established character for reliability. It is expected also that the Fulton-Alden plant will be able to furnish motors to the trade almost



View of a Manufacturing Section of the Plant immediately, as well as the well-known Fulton reproducer and other parts. With ample capital and facilities the company is certainly entering upon a new period of prosperity and progress.

Robert Fulton, president of the company, is a musician of high attainments who for twelve years past has been interesting himself in the sale and promotion of musical instruments. To him the inventor of the now characteristic Fulton system of reproduction came when the question of manufacturing an improved talking machine became practical. Starting in a small way and assisted by his own reputation for integrity, added to the banking knowledge and repute of his brother John, Robert Fulton, ably seconded likewise by Harry Howe, the company's efficient secretary, has gone on from success to success. The technical knowledge of Mr. Everett, now placed at the company's disposal, assures still more rapid development in every department.

Cabinets—Cabinets—Cabinets

For dealers, wholesalers and jobbers or those who desire to sell their own brand, style and make of talking machines. Let us figure on what you desire. We are not too busy to build your cabinets.

Chas. Passow & Sons
2121 to 2141 ALLPORT STREET CHICAGO, ILL.

STOCK SHORTAGE IMPROVES SALESMANSHIP IN PORTLAND

Clerks in Talking Machine Stores Now Actually "Selling" the Records That Are Available to Those Who Want Other Selections—Trade Working Hard in Liberty Bond Drive

PORTLAND, ORE., October 4.—While the Fourth Liberty Loan drive has somewhat affected the talking machine business in Portland for a week or two, there is little complaint from the dealers, most all taking an active part in the drive and showing more anxiety to have Portland the first to go "over the top" than to sell machines. In fact, it continues to be easier to sell machines than it is to get them. Customers are numerous, machines are scarce. The public appreciates the fact that certain records are impossible to get in large quantities and good-naturedly accept substitutes and are apparently well satisfied. The salesmanship of many young ladies in the record departments has very much improved since the war, as they have been taught how to make their customers want what they buy, instead of buying what they want.

The phonograph department of the Meier & Frank store is 100 per cent. loyal. Every employe has subscribed to the new loan. This is not surprising, as Julius Meier, head of the firm, is Lieutenant General of the Liberty Loan drive in Oregon. The store takes care of all Liberty Bonds bought. Business is very good in the big talking machine department. Records are sent out every week to Vancouver Barracks, Camp Lewis and to the Red Cross. J. H. Matney is manager of the department.

Paul B. Norris, of the Wiley B. Allen Co., had a most successful August month, September starting out in fine shape and prospects better than ever before. A number of changes have been made in the department. Mrs. Olga Binder, who has been in charge of the record department, has been promoted to the position of cashier, and Miss Serr, who assisted in the record department, has been given Miss Binder's former position. Miss Herbertina Perry, formerly of the Bush & Lane Co., is now assisting Miss Serr.

William Hodecker, who was in charge of the phonograph department of the Lucas-Seiberling Music Co., has entered the navy and is at present stationed at Bremerton.

The G. F. Johnson Piano Co. has added the Cheney phonograph to their stock. They now carry the Victor and Cheney in their admirably equipped talking machine department, which has recently been enlarged to meet the growing business.

There is a remarkable increase in sales of foreign records at the Columbia Graphophone Co. Many foreigners in the shipyards, with plenty of money, are eager to buy records of the songs and dances of their different countries. The sales people are kept busy attending to this class

of customers, which is steadily increasing. The Columbia is fortunate in having the services of Miss Olga B. Moreland, who is especially well qualified to handle the foreign custom, as she speaks French, Italian and German and can translate nearly every language satisfactorily for customers.

The Lucas-Seiberling Music Co. is doing a good talking machine business. While a number of young men employed in this store have gone to war their places have been supplied by capable young women. Miss Ruth Flannery is now in charge of the phonograph department and is filling the position very acceptably.

Okeh and Emerson records are becoming popular in Portland. The Sahlstrom Music Co. is selling great quantities of them. The Stradivara phonograph carried by this company has also been well received in Oregon. L. E. Gilham, manager, says business is very satisfactory.

A number of used talking machines which have been taken in exchange for the Sonora phonograph are offered at very reasonable prices at the removal sale of the Bush & Lane Co. The company will carry nothing but new stock to their new store in the Eilers Building, to which they will move on October 10.

Louis Older, who has been connected with the Columbia Graphophone Co. for a long time, has resigned his position as assistant manager and entered the automobile business.

L. C. Callahan, manager of the Columbia Dictaphone department, has returned from the training camp at Eugene, Ore. Mrs. Callahan is assisting him in the office, and should Mr. Callahan be called to war she will be able to keep on with the business. Mr. Callahan is waiting for a call to the officers' training camp at Camp Pike, Little Rock, Ark.

G. Guy Wakefield, of the Wakefield Piano Co., is very much gratified with the success of the Brunswick talking machines. Sales are very frequent and high-grade machines are preferred.

The Hyatt Talking Machine Co. is now occupying its handsome new store on Alder street. The store is in a most desirable location and is finely equipped and handsomely furnished. Mr. Hyatt is making arrangements for an opening very soon, which will be an event of prominence in the social and musical world of Portland.

C. A. Newman, in charge of the talking machine department of Graves Music Store, says the September business has been excellent.

Major I. Lowengart, chairman of the military relief committee of the Red Cross, Portland, Ore., has asked for phonograph records for the sailors on the "Western Coast," "Western Plain" and "West View," newly built ships. The dealers are very generous in giving records to the Red Cross for all purposes, and the citizens of Portland will no doubt supply the vessels with the desired records.

COMMISSION FOR KENNETH R. MOSES

Kenneth R. Moses, formerly sales manager for the Amberola line of Thomas A. Edison, Inc., has just received his commission as a second lieutenant in the Quartermaster Corps. Lieutenant Moses enlisted in May, 1917, as a private. He became a corporal—then a sergeant. With his appointment as a lieutenant came a transfer from Camp Wadsworth at Spartanburg, S. C., to Anniston, Ala., where he will be an assistant quartermaster at Camp McClellan.

A. J. KENDRICK IN GOTHAM

A. J. Kendrick, of the Chicago offices of the Brunswick-Balke-Collender Co., paid a visit to the New York headquarters of the company on a trip which combined business and pleasure. Mr. Kendrick was at one time a member of the New York staff.

The "Brownie Grand"

"The Talking Machine with a Silvery Voice"



Retail Price, \$150.00

Specifications

Unusually large, massive and handsome Cabinet made from the finest selected foreign and domestic hardwoods; size, 50 inches high, 23 inches wide and 24 inches deep; finished in a genuine piano polish, mahogany only. Has finest double spring motor; universal tone arm; playing perfectly any disc record made. Equipped with the latest style tone amplifier and modifier. Special resonant sound chamber scientifically constructed on acoustic principles. Unusually large record filing space.

Unusually liberal discounts to dealers, thereby insuring unusually good profits. Write us for full particulars—also about our exclusive agency in your territory.

Jobbers Attention

We make special machines under your own name, on contracts of sufficient size, when desired.

GARVIN-BROWN CO.
2501-2503 N. Western Avenue
CHICAGO, ILL.

DEALERS

Offset the Record Shortage!
Keep Your Sales-Force Busy!
Sell Our Language Records!



**French
Spanish
Italian**

ALSO

**F.M.C. FRENCH
MILITARY
CONVERSATION**

Cash in now on the

**Language Phone Method
and Rosenthal's Practical Linguistry**

It requires no scientific salesmanship to sell our records. The courses are so simply arranged that the demonstration satisfies the prospect. The French Military Course, 5 Double Discs, and Military Manual (Retail \$10.00) is ideal for Army, Navy, Red Cross

Our Display Signs Sell the Goods

Send for Particulars—Prompt Delivery

THE LANGUAGE PHONE METHOD
992 Putnam - 2 West 45th Street, - New York

Machines Will be Mighty Scarce This Fall

Build up your record business; train your sales force to understand the tremendous value of a profitable record business and be prepared to give your patrons efficient service and maximum convenience.

Van Veen Bed Set Booths



Will help you develop record business and enable you to give your customers 100% service.

Let us show you how our booths can aid you.

Send for a copy of our catalog.

Be a trade booster during war times; plan now for the future and your business will be in the front ranks when conditions become normal.

Arthur L. Van Veen & Co. 47 West 34th Street, New York
TELEPHONE - - - GREELEY 4749

EARLY CHRISTMAS BUYING BEING URGED IN LOS ANGELES

Curtailment of Sales Forces Offered as Chief Reason for Spreading Holiday Business—Swaps Music for Undertaking—Retail Dealers Hear Talk on Advertising—General News

LOS ANGELES, CAL., October 5.—That there will be a great shortage this fall in all makes of talking machines is the opinion of all Los Angeles jobbers and dealers. Not that this will be anything new to them, for there has always been a scarcity of both records and machines during the holidays and several months preceding them. Some of the dealers have made trips East to see if they could pick up a few machines and records in addition to what they expect to get from their local jobbers. However, the Eastern jobbers do not seem to be any better off than the Coast ones, and the outlook is not very bright. One good thing that the shortage has brought about is that all Los Angeles dealers are making more cash sales and demanding larger initial and monthly payments on lease sales.

Owing to the inroads that the draft has made on the sales forces in Los Angeles, the Chamber of Commerce is advising the public to do its Christmas shopping during October and No-

vember. This will be a great help to the dealers as with their present inadequate forces any kind of a holiday rush would "swamp" them. Business is good in spite of the many demands made upon the people in other ways. Fear of the revenue tax has been the means of closing many pending deals. The sale of records seems to be on the increase, although the shortage on a great many popular and standard selections has been considerable of a handicap to the dealers. Business as a rule is good in Los Angeles, and the merchants are looking forward to a normal holiday trade.

W. A. Salsbury, of the talking machine force of the George J. Birkel Music Co., is leaving the trade in the near future to engage in the undertaking business. He is one of the best-known talking machine men on the Coast.

At the last meeting of the Retail Talking Machine Dealers' Association, E. E. Powell, a Western authority on scientific salesmanship and advertising, gave an interesting talk on advertising musical goods in wartime. Mr. Powell brought up many interesting and useful points in his talk and was thoroughly enjoyed by those present.

One of the notable events of the year is to be the California Liberty Fair to be held at Exposition Park October 12 to 26. Among the interesting exhibits will be those from the Southern California Music Co. and the Burnham Phonograph Co.

Joseph Carter, with the Southern California Music Co. for the last five years, has accepted a position with Sherman, Clay & Co., of San Francisco.

The Burnham Phonograph Co., located at Nineteenth and Los Angeles streets, in this city, is one of the newest companies to enter the field as makers of talking machines. They are making six models in cabinet form. Mr. Burnham has established a considerable number of agencies in southern California.

A unique window display is being shown by the Southern California Music Co., 332 South Broadway. It is an exact replica of a dugout from information given by D. W. Griffith and members of his staff, who visited the battlefields of France in the preparation of his photo drama, "Hearts of the World." The dugout is complete in every detail, down to the famous

"buckboard" and camouflaged top. Within the dugout are found telegraph instruments, bunk and various war accoutrements, such as would be expected were one to pay a visit to the front. On the crudely fashioned table will be found copies of the "Stars and Stripes" and "Plane News," two publications gotten out by the soldiers in France. A window card also calls attention to the fact that the boys at the front need music. The local Red Cross is making a drive for musical instruments, records, sheet music, etc., and those having such articles to donate may leave them at the store, and they will be delivered to the proper authorities.

J. A. Frye, Victor factory representative from Camden, is in Los Angeles on a tour of inspection.

John Miller, road representative for Sherman, Clay & Co., of this city, has been called into service and is now stationed in San Diego.

The Stage Woman's Relief Society of Los Angeles recently purchased through the Southern California Music Co. a nice Victrola X for the U. S. "Schley," which has been lying in the harbor at San Pedro for the last two weeks. The crew were delighted with their beautiful gift. Mrs. Mason, wife of "Smiling Billy Mason," of "movie" fame, was the purchaser.

Barker Bros. have started their weekly Wednesday afternoon concerts for the season in their recital hall.

The Wilby B. Allen Music Co., 415 South Broadway, have taken the agency for the Brunswick phonograph and in the future will handle a full line of that make. Harold Jackson, their manager, reports the sale of three machines for Christmas delivery.

Through the medium of the local association of talking machine dealers an exchange has been arranged whereby a dealer with an overstock on certain numbers can exchange them with another dealer for selections that he is probably out of. This plan has worked out to advantage for all parties concerned.

All of the talking machine houses have rallied to the call for the Fourth Liberty Loan drive, and several of them have gone "over the top" already and the others will soon follow suit.

LOOKS FOR LARGE HOLIDAY DEMAND

Thomas Anderson, the enterprising furniture dealer of 717 Manhattan avenue, Brooklyn, N. Y., who represents the Sonora phonograph, reports a very active business in these instruments, and anticipates a large holiday demand. Mr. Anderson also carries a very extensive and complete stock of Pathé records and Pathé phonographs.

The more bonds you buy the fewer boys will die.

The Mutual

TONE ARMS & SOUND BOXES

Dealers

If you want the best, be sure that the machines you handle are equipped with



MUTUAL
TONE ARMS AND
SOUND BOXES

Mutual Talking Machine Co., Inc.
145 West 45th Street, New York

The BEST TALKING MACHINE NEEDLE

On the Market—Packed in Counter Salesman



50 Needles to a box and they retail at 10c. per Box.
60 Boxes to a package \$6.00.
This package costs you \$3.90 net.

Your profit is \$2.10 and your customer gets a needle that will give satisfaction.

The Fred. Gretsch Mfg. Co. 60 Broadway
Brooklyn, N. Y.
Manufacturers of Musical Instruments
Canadian Wholesale Agent, H. A. BEMISTER
10 Victoria St., Montreal, Can.

▪ The new large size ▪

Emerson

Records

TRADE

MARK

Retail at 75 cents

Emerson Phonograph Company INC.

3 West 35th Street

New York

Boston, 80 Boylston St.

Chicago, 7 E. Jackson Boulevard

Emerson
Phonograph
Company, Inc.
3 W. 35th St., N. Y.

Please send me
information about the new
large size Emerson Records.

Name

City

State

DEALERS IN BALTIMORE TAKING ON VARIOUS NEW LINES

Endeavor by That Means to Overcome Increasing Stock Shortage—Epidemic Serves to Postpone Meeting of State Dealers—Columbia Line for The Hub—Other News

BALTIMORE, Md., October 4.—August proved a good month for the retail dealers in the Baltimore district in talking machines, but not quite so good with the jobbers. This was due to but one cause, and that the lack of goods to take care of the ever-increasing demands. Dealers who have been handling certain exclusive lines for years sought other markets to obtain new lines during the past month, but did not meet with very much success. Those jobbers who had a fairly good supply of goods declined to take on any new lines unless the demand came from real high-class dealers with strong financial backing. Even then many of the jobbers insisted on first taking care of their old-established trade before looking after any new customers.

Phenomenal record business was reported in all quarters. But many sales were lost because many dealers failed to interest their callers in what they had in stock. Those dealers who sought to have their sales folks entertain and be courteous to callers when out of goods will surely benefit by this policy. Your correspondent witnessed several sales people merely reply "no" to a demand for certain records, but later saw a live and wideawake salesman entertain a customer with another record when he went to look for the record asked for, knowing at the same time that he did not have what was wanted. In this manner a number of records were sold and customers no doubt made for a firm that were lost by the other people.

The meeting of the Music Dealers' Association of Baltimore, which was scheduled for tonight, was called off because of the rapid inroads made by the Spanish influenza, which seriously crippled many of the firms during the past ten days. This meeting, which was planned to bring together all branches of the music trade, will be held at some future date. Joseph M. Mann, president of the association, was ill in bed during the entire week, and because of that fact and that other members were ill, the meeting was postponed.

Plans are already under way in Baltimore by some of the dealers to take an active part in the "Slacker Record Week," which is planned for October 26. These idle records will be gathered together and shipped to the various cantonments

in the vicinity of the city, there being close to 75,000 troops quartered within a short distance of this city at the various cantonments. Manager A. B. Feder, of the music department of Hecht Bros. Co., West Baltimore store, has already started to work on this plan. Others are expected to drop into line rapidly.

Those firms having machines are getting extraordinarily good terms and many cash sales are reported continually. The scarcity of goods has made the dealers realize that it is useless to sell anyone that desires a machine, unless they happen to be able to either pay cash, or make good payment and are of good financial standing.

An interesting announcement is that of the taking on of the Columbia line by the music department of The Hub, of which M. J. Rogers is manager. Manager Parks, of the local Columbia Co., put over a good deal in bringing this firm back in line, for this department at one time carried Columbia. Then it became an exclusive Victor dealer and now sells both the Victor and Columbia machines and records. This department has just been moved to a new section of the building, and it has plenty of booths for displaying.

Business with the Columbia Co. here during the month was phenomenal, according to William S. Parks, the local manager. When August closed there was not a single machine of any design left in the Baltimore headquarters except an old period model in the manager's office. The firm also made a large shipment of records and closed the largest month's September in the history of the branch. During the month Mr. Parks made a trip to Charlotte, Raleigh, Richmond and Washington. He also visited New York and managed to get some goods started to his branch. George W. Hopkins, general sales manager of the Columbia, was in Baltimore during the month and attended a sales meeting of the branch. He said he was well pleased with the way things were going here. W. C. Kobin, who is in charge of the Dictaphone department for Columbia, came to Baltimore, talked Dictaphones to that branch here, and September proved to be the best sales month the Baltimore office has had to date. J. C. Nace has been placed in charge of the rec-

ord department of the company and succeeds H. Z. Bangs, who resigned to enter other business.

Homer L. Kitt, of the Arthur Jordan Piano Co., Columbia and Victor dealers, was a visitor to Columbia headquarters during the month. Mr. Tesh, of Rominger Furniture Co., Winston Salem, N. C.; Henry Resch, of the M. M. Crocker Co., Inc., Portsmouth, Va.; and I. K. Hunter, Washington, were also visitors.

J. B. Ivy, of J. B. Ivy & Co., Charlotte, N. C., was in Baltimore during the month and has just signed a Columbia contract.

W. C. Roberts, of E. F. Droop & Son's Co., Victor distributors, reports a fine retail business at the Baltimore headquarters, but a falling off of the wholesale business because of lack of goods to handle the demand. Mr. Roberts made several trips to New York, Camden, N. J., and Philadelphia during the month in quest of goods, but without much success. Mr. Roberts managed to get in a good shipment of "Smiles" and "Baby's Prayer at Twilight," both of which are big sellers, and these shipments managed to keep the right side of the ledger in good shape. Visitors to the Droop salesrooms from out-of-town included D. W. Branch, Petersburg, Va.; W. Newman, Chestertown, Md.; Max Levy, Norfolk; Mr. Gewehr, of the Gewehr Piano Co., Wilmington, Del.

Cohen & Hughes, Victor distributors, report business only fair with the loss of many sales because of lack of goods to fill orders. During the month I. Son Cohen, of the firm, spent most of his time visiting Camden and other points in an effort to get goods, but without much success. Visitors to the firm included Mrs. Walrath, manager of the music department of the Kaufman stores; Mr. Caulfield, of Burk, Helm Co., Norfolk; Max Levy, Norfolk, Va.

Jesse Rosenstein, for the National Piano Co., returned this week from a visit to the Pathé headquarters and hopes to be able to get a big shipment of instruments shortly. Miss Hartung, head bookkeeper of the firm, is seriously ill with the grip. Business with the firm is good.

W. L. Loomis, manager of the Victrola department of Hochschild, Kohn & Co., has just returned to his office after a serious spell of illness.

Many members of the talking machine trade, both employers and employes, are suffering from some form of influenza these days.

For Gen. Foch and Freedom—buy Bonds.

Lyon & Healy Piano Polish and Machine Oil Have No Equal

Is especially adapted for restoring and preserving original lustre on Pianos Talking Machines Fine Furniture Automobiles and all Finished Surfaces



When Properly Applied Perfect Results Guaranteed

Safe for the Finest Finishes

Requires no Shaking of Bottle

Write for special prices in Gross and Gallon lots.

Prevents Rust Will not gum Contains no acids

Spring Bottom Spout Can



No. 76

Useful for many purposes, one dozen in a package, \$1.20 per dozen. Retail price, 20c. per can.

Indispensable for Lubricating Friction Parts on Pianos Talking Machines

Everything known in Music

Lyon & Healy

CHICAGO

Neatly packed in attractive display case containing 12 bottles, \$2.65 per dozen. Retail price, 50c. per bottle.

REST ROOM FOR MEN IN SERVICE

Edison Shop Arranges Second Floor of Edison Building for This Purpose

A rest room for soldiers, sailors and marines, under the direction of the Mayor's Committee of Women on National Defense, has been opened on the second floor of the Edison Building at 473 Fifth avenue. It is directly opposite the Public Library and is known as the "Edison Shop." Edward C. Boykin, general manager of the Edison Shop, gave the room to the Mayor's committee and has installed two Army and Navy phonographs. The latest magazines are on file. Lounges at either end of the room are equipped with reading lights. There are three writing tables.

"Observing the thousands of sailors and soldiers who visit the canteen across the way and then stroll aimlessly up and down Fifth avenue," said Mr. Boykin, "I thought they might like this room to read and write in. It will be cold soon and the men can well use a warm place of this sort."

REMOVE TO NEW QUARTERS

The Sona-Tone Phonograph, Inc., Now Located at 322 Livingston Street, Brooklyn

The Sona-Tone Phonograph, Inc., manufacturer of the Sona-Tone phonograph, has moved its executive and sales offices from 3429 Broadway, New York, to 322 Livingston street, Brooklyn, N. Y. At the latter address the company has adequate space for the presentation of its line and the salesrooms are being arranged to afford visiting dealers an opportunity to thoroughly test the constructional qualities of the Sona-Tone phonograph at their convenience. The location of the new salesrooms is very desirable, as they are located near the Nevins street subway station and can be reached from Wall street in about five minutes.

The company's factory is now located at 691 Bergen street, Brooklyn, N. Y., where the plant is working to its limit to keep pace with the demands of the dealers. Automobile delivery truck facilities have been arranged to give the New York City district quick and efficient service as well as to provide for speedy deliveries to the express offices for out-of-town shipments. Sona-Tone dealers report an active demand for this phonograph, which, judging from the letters received at the executive offices, is giving excellent service.

SOME RECENT COLUMBIA VISITORS

Among the visitors this week at the executive offices of the Columbia Co. were R. R. Sparrow, assistant manager of the Columbia Co.'s Atlanta branch, and M. C. Perkins, assistant manager of the Boston branch. Both of these visitors spoke optimistically of the business situation in their respective cities and made a unanimous plea for the shipment of merchandise.

George W. Hopkins, general sales manager of the Columbia Co., returned this week from a visit to the company's Buffalo and Toronto headquarters. The business situation in Canada is splendid and James P. Bradt, who is in charge of the Columbia Canadian business, is achieving remarkable success in putting Columbia product "over the top."

J. D. Elliot, manager of the talking machine department in the Shepard Co.'s store, Providence, R. I., was another caller at the Columbia offices this week, bringing with him pleasing reports of the business being closed by this well-known house.

George W. Hopkins, general sales manager of the Columbia Co., made a flying visit the end of last month to the Philadelphia and Baltimore branches of the company, where he attended and addressed informal meetings of the sales organizations of these two branches in his usual inspiring manner.

With Cabinet Machines Scarce—

and small "Victrolas" being strongly advertised, you have a most unusual opportunity for selling "Converto" Cabinets. It is better business for you to sell a small "Victrola" and Converto Cabinet than to try to substitute some other cabinet machine—because you know a genuine Victrola will satisfy and has the public confidence.



Patented December 11, 1917

TALKING MACHINE CABINET

This Patented cabinet is *your opportunity*. It fits present-day needs of customer and dealer as nothing else does! Write or wire your wholesaler for prices and particulars.

The C. J. Lundstrom Mfg. Co., Little Falls, N. Y.

NOTICE: Lundstrom Converto Cabinets are broadly covered by patents. Infringement will be promptly prosecuted.



Setting Victrola into Cabinet

Sound Doors Open for Playing

Converto Wholesalers

- | | | | |
|----------------------|----------------------------------|-----------------------|------------------------------|
| Austin, Tex..... | The Talking Machine Co. of Texas | Newark, N. J..... | Price Talking Machine Co. |
| Baltimore, Md..... | Cohen & Hughes | New York, N. Y..... | Emanuel Blout |
| Birmingham, Ala..... | E. F. Droop & Sons Co. | | S. B. Davega Co. |
| Boston, Mass..... | Talking Machine Co. | Omaha, Neb..... | Mickel Bros. Co. |
| Burlington, Vt..... | Oliver Ditson Co. | Peoria, Ill..... | Putnam-Page Co., Inc. |
| Butte, Mont..... | American Phonograph Co. | Philadelphia, Pa..... | The George D. Ornstein Co. |
| Chicago, Ill..... | Orton Bros. | | Penn Phonograph Co., Inc. |
| Cincinnati, O..... | Lyon & Healy | | H. A. Weymann & Son, Inc. |
| Cleveland, O..... | The Rudolph Wurlitzer Co. | Pittsburgh, Pa..... | W. F. Frederick Piano Co. |
| Columbus, O..... | The Collister & Sayle Co. | | C. C. Mellor Co., Ltd. |
| Dallas, Tex..... | The Perry B. Whitsett Co. | | Standard Talking Machine Co. |
| Denver, Colo..... | Sanger Bros. | Richmond, Va..... | The Corley Co., Inc. |
| Elmira, N. Y..... | The Knight-Campbell Music Co. | | W. D. Moses & Co. |
| El Paso, Tex..... | Elmira Arms Co. | St. Paul, Minn..... | W. J. Dyer & Bro. |
| Kansas City, Mo..... | W. G. Walz Co. | Syracuse, N. Y..... | W. D. Andrews Co. |
| | J. W. Jenkins' Sons Music Co. | Toledo, O..... | The Whitney & Currier Co. |
| | Schmelzer Arms Co. | Washington, D. C..... | Cohen & Hughes |
| Milwaukee, Wis..... | Badger Talking Machine Co. | | E. F. Droop & Sons Co. |



Otto Heineman Phonograph Supply Co.

INCORPORATED

25 WEST 45th STREET, NEW YORK

FACTORIES, ELYRIA, O.—NEWARK, N. J.
PUTNAM, CONN. SPRINGFIELD, MASS.

CHICAGO

ATLANTA

SEATTLE

TORONTO



OKEH RECORDS

NOW READY FOR IMMEDIATE DELIVERY

A straw shows the way the wind blows

The special release of the four biggest sellers on the market, and the extra big runs to supply the great public demand, show the kind of service you get on

OKEH RECORDS

These four and many other numbers ready!

1074 { **Oh! How I Hate To Get Up in the Morning!**
(Irving Berlin) Irving Kaufman
The big hit of Yip, Yip, Yaphank. One of the best war comics with a swinging marching tune.

1074 { **Good Morning, Mr. Zip, Zip, Zip**
(Lloyd) Arthur Fields
A rollicking, catching, nonsensical, enjoyable comic. You can't get it out of your head and yet it gets in your feet.

1072 { **I'm Sorry I Made You Cry** (Clesi) Irving Kaufman
Probably the best seller of the kind on the market.

1072 { **I Hate To Lose You**
(Clarke-Gottler) Elaine Gordon
If getting used to a person is love, then this is a love song.

1086 { **Smiles** (Callahan-Roberts) Ruth Lenox and Franklin Keat
"There are smiles that make you happy."—This great contralto and baritone duet is one of them. A great popular favorite and a big seller.

1086 { **Since I Met Wonderful You**
(McDonough-Hubbell) Sam Ash
Mr. Ash has one of the best recording voices and he certainly puts it over in the big hit of the "Kiss Burglar."

1073 { **When You Come Back**
(George M. Cohan) Sterling Trio
Mr. Cohan sends a great message to the boys over there—a message backed by America, One Hundred Million strong.

1073 { **Hearts of the World** (Costello-Casey) Charles Hart
A tender war ballad that introduced every performance of Griffith's great picture, "Hearts of the World."

LOOK at the list of late records shown in the back of this copy of the Talking Machine World

WRITE for complete catalog

OKEH RECORDS

NOW READY FOR IMMEDIATE DELIVERY



Otto Heineman Phonograph Supply Co.

INCORPORATED

25 WEST 45th STREET, NEW YORK

FACTORIES, ELYRIA, O.—NEWARK, N. J.
PUTNAM, CONN. SPRINGFIELD, MASS.

CHICAGO

ATLANTA

SEATTLE

TORONTO



Longer evenings now — cooler weather.
Folks are staying indoors after supper.
That spells B-U-S-I-N-E-S-S to live dealers.

Columbia Graphophone Co.
NEW YORK



TALKING MACHINE MEN FORM A LIBERTY LOAN LEGION

At Enthusiastic Meeting on October 7 Under the Auspices of the Allied Music Division Members of the Trade Pledge Themselves to Work for a New High Record in Bond Selling

More than seventy-five members of the talking machine industry assembled in the meeting rooms of the Merchants' Association on Monday afternoon, October 7, to attend a meeting which was called by the Allied Music Committee to form a volunteer army to work in behalf of the talking machine interests in the Fourth Liberty Loan. Roy J. Keith, chairman of the wholesalers' division of the Talking Machine Committee, arranged the details for the meeting, which was successful beyond expectations and which indicated that every member of the talking machine industry will work indefatigably to bring the total for the Talking Machine Committee far over the prescribed quota.

Mr. Keith presided as chairman at the meeting on Monday, and as the first speaker introduced Morris K. Parker, a member of the Central Liberty Loan Committee, who is directly responsible for the success achieved by the members of the Rainbow Division. Mr. Parker gave an interesting talk regarding the different features of the loan and emphasized the fact that the members of the industry in securing subscriptions for the Fourth Liberty Loan should "do it and do it now" and "keep the bonds sold," and that every volunteer should impress upon the purchaser of bonds in this loan the importance of keeping the bonds and not disposing of them unless absolutely necessary.

Lieutenant Gitz-Rice, of the Canadian Army, who spent three years in the trenches "over there" as a member of the First Canadian Contingent, gave an interesting talk regarding the work of the boys in the trenches. Lieutenant Gitz-Rice, who is also well known in musical and theatrical circles, made a stirring appeal in behalf of the loan and favored the audience with the rendition of his famous popular song "Keep-Your Head Down, Fritzie Boy."

Mark P. Campbell, chairman of the Allied Music Committee for the Fourth Liberty Loan, was the next talker and gave a straight-from-the-shoulder address, telling the members of the talking machine industry that the Liberty Loan Committee had adopted as a slogan "Music Maintains Morale" and suggesting that this slogan be used wherever possible. Mr. Campbell, during the course of his address, pointed out that Great Britain had listed the four essentials of life in the following order: food, shelter, clothing and music, and that this recognition by England of the importance of music is reflected in the entertainment afforded the English Tommies in camp by every form of music that is possible.

The surprise of the afternoon was the introduction of Private Shay, of the Fifty-ninth Regiment, Brooklyn, N. Y., who returned from abroad a few weeks ago in order to help the Liberty Loan Committee put this loan "over the top." Private Shay, who is one of General Pershing's veterans, participated in the fighting

at Chateau-Thierry and Soissons, and, although wounded several times, persisted in returning to the front until he was finally ordered to a base hospital, from which he left for New York to help the Liberty Loan officials. Private Shay spoke at length upon the tremendous value of music to the boys at the front, giving numerous instances which indicated that music certainly maintains morale among the fighting men and keeps the boys in good spirit. His address was enthusiastically received by the members of the industry, who, after listening to some of the atrocities committed by the Huns, were in a mood to go out and solicit subscriptions for the Fourth Liberty Loan that would complete the industry's quota within twenty-four hours.

J. Newcomb Blackman, vice-chairman of the Allied Music Committee and directly in charge of the talking machine division, gave a splendid talk on the details of the Liberty Loan work being done by the talking machine division, and asked the members of the trade to get together and co-operate efficiently in order that the industry may go on record in Washington as 100 per cent. plus in the Fourth Loan. Mr. Blackman gave full details regarding the work cut out for the volunteers and his interesting and

inspiring talk was most heartily applauded.

Harry McClaskey, well-known tenor, who records for many of the leading companies, was a guest at this meeting and favored the audience with several selections; the meeting coming to a close with the singing of the "Star Spangled Banner."

PHONOGRAPH INSPIRED HIM

MILWAUKEE, Wis., October 5.—The phonograph can inspire patriotism, it seems, for according to First Sergeant Henry W. Schwab, son of G. F. Schwab, 2229 Center street, his war enthusiasm dated back to 1904, when a phonograph first entered his home.

"I used to listen to the patriotic records and it just made me want to be a soldier," said Sergeant Schwab, who is visiting in Milwaukee. He is in charge of the marine recruiting office at Cleveland and has been in service since December, 1904, seeing action in Cuba and Porto Rico. For seven years he was in the Quartermaster's Department.

TALKING MACHINE MEN TO MEET

The regular monthly meeting of the Talking Machine Men, Inc., will be held in the assembly rooms of the Bush Terminal Building, 130 West Forty-second street, at 2 p. m. on Wednesday, October 16.

Prepare for Easy Handling

Insure Perfect
'Delivery

"Khaki" Moving
Cover, Felt-padded,
Fleece-lined, Quilted,
Strongly Sewed.

No. 804

Price \$7.00

Mention style of Machine when ordering.

JOBBERs: Write for special offer.

LYON & HEALY

::

::

CHICAGO



Heavily
Padded
with
Substantial
Felt

Days of Certainty and Uncertainty



THESE are days of certainty and, too, days of uncertainty. Certainty that we are going to win this war, cost what sacrifice it may. We are going to win it, because we have set that task for ourselves and it is not the spirit of America to leave such a job unfinished.

Uncertainty, that we do not know from day to day just how the tide of events is going to affect this, our business.

Uncertainty, because we cannot follow certain business policies, which during times of peace would be a simple course. We cannot, because of the bigger business.

But certainty, that we are going to do our best to keep our "home wheels" turning, for we believe that to be a big part of the day's programme.

And certainty again, that we feel deeply our responsibility, our part, of the bigger business and are backing it and stand ready to back it to the very limit of our strength, our ability and our resources.

Cordially yours,

Vice-President

STEPHENSON, INC., One West 34th Street, New York

Manufacturers of the Stephenson Precision-Made Motor

TREMENDOUS DRIVE FOR "SLACKER" RECORDS COMING

Members of National Phonograph Record Recruiting Corps Hope to Gather at Least 1,000,000 Records From Public for Distribution Among Soldiers and Sailors

The week of October 26 to November 2, designated as "Slacker Record Week," will mark seven red-letter days in the social and musical life of the several million soldiers and sailors who go toward making up Uncle Sam's quota of fighting strength in the great world war.

During these seven days the National Phonograph-Records Recruiting Corps will comb the country from end to end in search of slacker

ica respond with a never-ending stream of records, needles and instruments.

Indeed, the military authorities attach so much importance to the matter of music in the building up of the soldier's morale that Major-General Franklin J. Bell has accepted the honorary chairmanship of the movement to mobilize all the available phonographic music power of the country, while the Advisory Board is made up of Lee F. Hanmer, Army and Navy Department's Commission on Training Camp Activities; Chester J. Teller, Jewish Welfare Board; Orlando F. Lewis, War Camp Community Service; William J. Mulligan, Knights of Columbus; Captain George Darby, Salvation Army; J. F. Jerome, Y. M. C. A. War Work Council; and Miss Katherine Scott, Y. W. C. A. War Work Council. Its National Committee includes, besides General Bell and V. Burnett, such well-known persons as Mrs. Newton D. Baker, Mrs. Franklin K. Lane, Major-General Thomas H. Barry, Enrico Caruso, Madame Galli-Curci, John McCormack, Madame Schumann-Heink, Major-General Hugh L. Scott, Lieutenant John Philip Sousa, Miss Ida M. Tarbell, and a hundred and fifty other men and women of equal prominence in the social, military, musical and public life of the nation.



Enjoying Talking Machine Music in Camp Community House

records, idle needles, phonograph instruments that aren't working, and every one of such that is located will be promptly reported to the organization's headquarters at 21 East Fortieth street, New York, which will in turn see that it is sent into the much-needed service of its country.

For that, briefly, is the mission of the movement supported by a number of prominent people—to get every idle phonograph, disc and needle out of the homes of the country and into the camps and training stations at home and abroad; into the hospitals and battleships; into the dugouts and, yes, even into the trenches, right under the noses of the big gums themselves.

For in all these places, say the greatest military authorities, there is a crying need for canned music. And in the vast majority of these places, declare the same authorities, the dearth of the canned music commodity threatens to increase out of all proportion to the supply unless the patriotic phonograph "fans" of Amer-

In five hundred cities and towns throughout the country local committees are already at work to make "Slacker Week" a memorable occasion, not only for its resultant effects upon the morale of camp life whether at home or overseas, but as an earnest of the desire of the American public to "do its bit" if necessary ten times over.

Dealers desiring to co-operate will be heartily welcomed to the fold. Get in touch with headquarters in New York. The movement merits the support not only of the public but of the retailers who can thus find an avenue for real service.

LIBERTY LOAN ISSUE OF "NEWTS"

Frank T. Nutze, of Stephenson, Inc., Writes Touching Story to Show Why Every Man Should Do His Utmost in Subscribing for Bonds—What a Spartan Mother Is Doing

Frank T. Nutze, secretary of Stephenson, Inc., well-known motor manufacturers, who contributes much of interest to the columns of the company's house organ, "Newts," has given over the September issue to the following touching and characteristic Liberty Loan story from his own pen. It is a story that should result in substantial additions to the Liberty Loan subscription list from all those who are privileged to read it. Under the title "The Gold Over the Blue," Mr. Nutze writes:

"Frequently on my trips between the Big City and Washington—Washington, N. J.—I pass a little white house alongside a certain part of the way. It lies at the foot of a hill, and in front of it there is a brick wall and a green, velvety lawn slopes down to this wall. And always, as I pass, in the sitting room window I see a dear little gray-haired woman, and always she sits there, rocking and knitting, rocking and knitting. And in this window there hangs a service flag, with just one star in the center . . . and I know that she knits for her boy, her boy 'over there.'

"And two weeks ago I again passed along this way and passed the little white house at the foot of the hill. And I saw her there in the sitting room window, rocking and knitting, rocking and knitting. And the service flag was in the window, too, but there was a gold star over the blue and only the edges of the blue did show . . . and she sat there rocking and knitting, now for some other boy 'over there.' for hers, her boy, had made the supreme sacrifice. And I knew that her sorrow was sweetened by the thought that she had been able to make the greatest contribution of all—her boy.

"Brother, we can't all make that contribution—the greatest contribution of all. That honor is only for the comparative few. But we can help. And to-day, right now, our country calls upon us for that help. It calls upon us to lend our dollars. It called upon that little gray-haired woman to make the greatest contribution of all, her son, and she answered, faithfully and nobly. It called upon her boy to give his all, his life, and he answered bravely and fearlessly. And now it calls upon us. Answer it quickly, brother, quickly and generously. Answer it to-day with a full heart, that the curse may be driven from the land and this hell's work done for evermore."

The VIVITONE

Sample free

to any dealer. Hundreds of dealers who seek to sell goods that surely create Good Will have taken advantage of this offer. You, too, will find an eager response from the buying public. Write on your letterhead for Dealers' Proposition and we will send free sample at once. It is a staple and an easy seller.

VIVITONE

The Vivitone Controller produces a vivid, pure and vibrant tone. It is a tube inserted into the needle post of the sound box. Then the steel needles are inserted and may be withdrawn in the usual manner.

The Controller eliminates all blasting, harsh and strident effects of the steel needles. A heavy or loud needle is preferably used, as this reproduces the true color and value of the tone of instrument or voice.

Favorite records take on new Richness of tone with the use of the Vivitone. It can be used with all phonographs that use either ordinary steel or Tungsten needles.

To demonstrate it is to change a prospect into a buyer. Remember there are ten million phonograph owners who are prospective buyers.

Each package contains four tubes which will play thousands of records and retails for 50c. Very liberal discount to dealers.

Vivitone means live tone and is rightly named.
It does NOT deaden the sound if rightly used.
Victrolas, Columbias and Vocalions sound better.
Instrumental and vocal selections are improved.
The mechanical sounds disappear.
One controller plays several thousand records.
No argument is needed—just a demonstration.
Every record buyer is your prospect.

VIVITONE CONTROLLER COMPANY

400, 401, 402 BELL BLOCK

CINCINNATI, OHIO

URGES PEACE PREPARATION

Senator Weeks Proposes a Congressional Reconstruction Committee

WASHINGTON, D. C., October 8.—Creation of a special Congressional committee on after-war reconstruction is proposed in a resolution introduced to-day by Senator Weeks of Massachusetts. He said the end of the war might come sooner than many expected, and that the country should be prepared with a program to meet the situation.

"At the end of the war," said Senator Weeks, "we are likely to have a merchant fleet larger than that of any country in the world. We have constructed some of the greatest shipbuilding plants in the world, and it is probably safe to say that those will have a capacity under after-war conditions sufficient to build and repair the merchant fleets of the civilized world. What are we going to do with these shipyards?"

"What are we going to do with all the manufacturing plants and other establishments created for war purposes, the machinery for which

may or may not be available for after-war production? What are we going to do with the millions of war workers now employed and who will find themselves out of employment at once when peace has been declared? The Government must take some action to protect these war workers."

UNUSUAL TEST FOR THE NEW EDISON

That the new Edison is capable of standing up under extraordinary strain is evidenced by the performance of an instrument at McDaniel's Restaurant, Newark, O. This instrument was installed some twenty-one months ago and has been continually used, night and day, ever since. Figuring conservatively, at one hundred Re-Creations played each and every day for the full period of twenty-one months, it will be seen that over sixty-three thousand pieces have been played by this instrument. A performance like this is worthy of commendation. The instrument to-day is in perfect condition, flawless in every particular, and during the entire period it has not needed nor had repairs of any kind.



An immediate opportunity for the progressive dealer

LAY IN A STOCK OF LYRIC RECORDS

**They sell themselves
and sell your machines**

LYRIC RECORDS appeal because of their wonderful natural tone and musical quality—and because there is no surface scratch.

LYRIC RECORDS can be played without an attachment on all machines equipped with the universal tone arm; and on old-style machines, by using a standard attachment.

THE LYRIC CATALOGUE includes all that is best in the world's literature of standard songs, operatic arias, instrumental solos, band and orchestra records, etc.

NEW BULLETINS issued monthly, giving the best of the new song hits and dances.

Inquire of Your Jobber

OR WRITE TO

Lyrphone Company of America
Manufacturers

12-14 WEST 37th STREET NEW YORK, N. Y.

REPAIRS

TALKING MACHINE TROUBLES AND HOW TO REMEDY THEM

Conducted by Andrew H. Dodin

[This department of The Talking Machine World is designed for the service of all classes of our readers, including those who make, and those who sell, talking machines. Andrew H. Dodin, who conducts this department, has a wide and enviable reputation as a repairer of talking machines and conducts an exclusive talking machine repair shop at 176 Sixth avenue, New York. Tell him your troubles through The World and he will help you if possible. The service is free.—Editor.]

SOME QUERIES AND ANSWERS

September 25, 1918.

Talking Machine World Repair Column:

I have had trouble with Victrola 6 winding shafts breaking off in the winding key—is this caused by defective parts or lack of oil? Have sent motors to our distributors and had new winding shafts put in and they break off in the same way. Can you tell us anything we can do to prevent this?

M. S. G. Co., New York.

ANSWER—If you replace motor in cabinet without putting the rubber or felt washers on the motor board screws, between the cabinet lid and motor casting, the result will always be broken winding shafts. These little spacing washers bring the winding shaft and hole in winding key escutcheon into correct alignment and should never be left out in replacing a motor.—A. H. Dodin.

September 10, 1918.

Talking Machine World:

Can you tell me where to obtain a list of the sizes and lengths of main springs used in different talking machine motors?

N. Steel Co.

ANSWER—Do not know of any list other than one published by the "Voice of the Victor"—the trade paper of the Victor Talking Machine Co.—giving the lengths and widths of all Victor main springs.

September 20, 1918.

Editor Talking Machine World:

Dear Sir—Can you tell us where to get the wax preparation used on sound boxes where the needle arm touches the mica? We have tried beeswax, but it seems to be too soft. Also would like to know if it is necessary to put this wax on both sides of the mica.

L. Kremer.

ANSWER—Mix two parts of beeswax and one part rosin—heat this mixture until it will run and stir together thoroughly and the result should be a good mixture which will not be hard enough to crack or soft enough to spread when touched. It is not absolutely necessary to place wax on both sides of the mica. The wax is placed at this point to make a positive airtight connection.

ATTRACTIVE ANNA CASE WINDOW

An Anna Case window display at the Edison Shop, New York, recently, despite its simplicity, attracted an unusual amount of attention. The display consisted of one large photograph and twelve small photographs of Miss Case, set off by pieces of plush, with appropriate signs asking the public to step in and hear the Re-Creations of her voice on the New Edison.

SCHUBERT Double Disc RECORDS

A \$30 Record Investment Starts YOU with complete, up-to-date list of Popular Vocal and Instrumental Selections

10-INCH DOUBLE DISC

20 to 30 New Selections Monthly

We guarantee you against loss of Record Investment.

Liberal Discounts Send for Details

BELL TALKING MACHINE CORPORATION

(Record Department)

44 WEST 37th STREET, NEW YORK, N. Y.

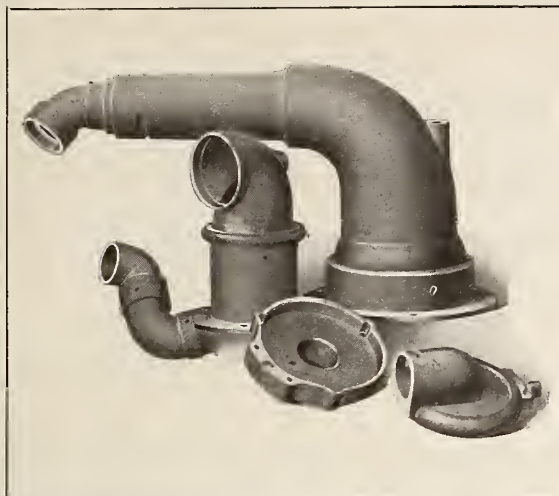

DOEHLER DIE-CASTINGS

for tone arms, sound boxes and talking machine attachments are STANDARD throughout the industry.

Of the many instruments produced to-day from the most prominent makes down, the greater number, by far, are equipped with Doehler die-cast tone arm and sound box.

The enormous output of our three large plants permits of advantages to the users of die-castings, as regards prices and deliveries, not otherwise possible.

DOEHLER DIE-CASTING CO.

MAIN OFFICE AND EASTERN PLANT
 BROOKLYN, N. Y. NEW JERSEY PLANT
 WESTERN PLANT
 TOLEDO, OHIO. NEWARK, N. J.

RAISE OVER FOUR MILLIONS AT LIBERTY LOAN RALLY

Talking Machine Men Play Prominent Part in Success of Demonstration of Allied Music Trades at Carnegie Hall, New York—Caruso, Galli-Curci, McCormack and Heifetz Appear

It took active work on an adding machine to keep track of the Liberty Loan subscriptions that poured in at the great rally and concert of the Allied Music Division, Fourth Liberty Loan, at Carnegie Hall, New York, on Monday night, September 30, and when, after an hour of excitement, the officials called a halt, a total of over \$4,000,000 in subscriptions was announced. It topped the rally last spring by over \$1,500,000, and the amount subscribed is held to be the largest ever realized at any single gathering in this country since the beginning of the war.

Individual subscriptions came so fast that it

The sum total of the concert is that the Allied Music Division succeeded in passing its quota mark of \$4,000,000 within three days after the official opening of the drive, and with nearly



John McCormack

was impossible for J. Newcomb Blackman and his valued assistants to tabulate and credit them accurately, but they ranged in amounts from \$50 up to hundreds of thousands each, subscriptions from \$25,000 to \$100,000 being so frequent they were common; the largest single subscription was that of the Victor Talking Machine Co. for \$500,000.

The announcement that four of the most prominent artists in the world—Galli-Curci, Heifetz, Caruso and McCormack—would appear on one program at the rally served naturally to fill Carnegie Hall to the limit, and everyone who was fortunate enough to receive a ticket had first to sign a Liberty Loan subscription blank for a substantial amount at the headquarters of the Allied Music Division. The larger the subscription the better the seats, and the best boxes brought \$100,000 each. This forehanded method of disposing of the seats resulted in subscriptions of something over \$2,000,000 before the doors opened.



Enrico Caruso

three weeks in which to work along ordinary lines toward the announced goal of \$6,000,000 for the music industry and profession. From an artistic standpoint the concert was a huge success, due largely to the efforts of C. G. Child, head of the recording department of the Vic-



Jascha Heifetz

tor Talking Machine Co., and chairman of the concert committee of the Allied Music Divi-

sion, who arranged the details of this event.

Arthur Pryor's American Band opened the program with the playing of a number of popular selections, and then as the spotlight fell upon a detail of marines and bluejackets with bayonets fixed crouched about the flag in its defense, John McCormack sang "The Star Spangled Banner," as few of the audience ever heard it sung before. It was a thrilling moment. Mr. McCormack then held the stage with his singing of "Dear Old Pal of Mine," by Lieut. Gitz-Rice, "Keep the Homes Fires Burning," and as an encore, his famous prayer song, "God Be With Our Boys To-night."

Jascha Heifetz played Chopin's "Nocturne in E Flat Major," and the Introduction and Tarentelle by Sarasate, and then responded to several encores. He was in splendid form.

Galli-Curci, the latest sensation in opera, sang "Caro Mio Ben," by Giordani; "The Lass With



Mme. Galli-Curci

the Delicate Air," by Dr. Arne, and the mad scene from "Lucia." The soprano aroused the greatest enthusiasm. As encores she sang "Drink to Me Only With Thine Eyes," and then "Annie Laurie" in English.

Caruso sang several light selections in his inimitable style, and then the stirring number "Victory, Victory," accompanied by Pryor's Band, the English words of which were written by his wife. It was when Caruso sang "Over There," first in English and then in French, however, that the audience jumped to its feet and gave the tenor the reception of the evening. He closed with a thrilling rendition of the "La Marseillaise" in French.

The speaker of the evening was Job E. Hedges, who was introduced by Benjamin Strong, chairman of the Liberty Loan Committee, and who made one of the best addresses of his career. Mr. Hedges led up briefly to the cause of the war, and why America was in

(Continued on page 94)

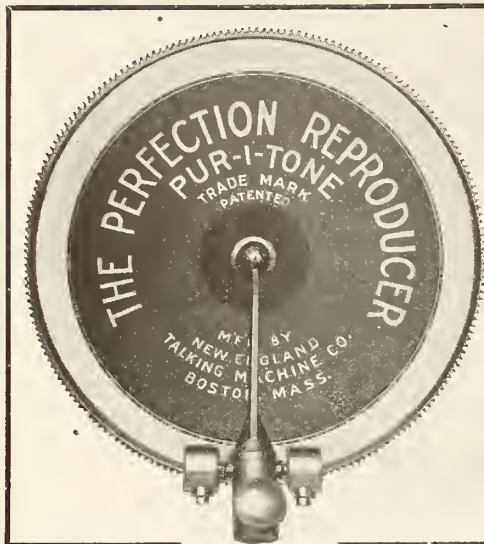

PHONOGRAPH DEALERS

Our new PUR-I-TONE reproducer No. 11 fitted to all types of Victor machines, for playing Edison disc, Pathé and all other makes of hill and dale records, is now ready for shipment. This new reproducer is easily the finest reproducer of its kind manufactured, as it reproduces ALL hill and dale records with wonderful clarity of sound, with great volume. The reproduction of Edison disc records is especially fine, and is sure to satisfy the most exacting critics. Reproducer MUST be heard to be appreciated. Gold sample sent on receipt of \$4.00; nickel, \$3.75; quantity prices on application. Money refunded if not thoroughly satisfactory.

Manufactured by

NEW ENGLAND TALKING MACHINE CO.

Largest Manufacturers of Phonograph
Accessories in the World

16-18 Beach St.

Boston, Mass.

LIBERTY LOAN RALLY A SUCCESS

(Continued from page 93)

it, and aroused great enthusiasm on several occasions. His condemnation of German kultur and German practices were of the strongest.

In urging support of the loan Mr. Hedges said: "The test of patriotic generosity is not what we give but what we have left. May we say we gave our all. The question to be answered is, whether we are to live by the grace of God, or by the favor of man."

A distinctive patriotic touch was given to the meeting by the presence on the stage of details of American soldiers, bluejackets and marines, together with eight members of the French Foreign Legion, two of whom, Capt. Druland and Lieut. Ramelet, are wearers of that coveted decoration, the Legion of Honor. A detail of Brazilian marines also appeared.

Just before Caruso sang J. Newcomb Blackman, vice-chairman of the concert committee, took the stage and in a live address told of the object of the rally, how the distribution of

tickets had been made the means of getting new subscriptions, and how it was hoped that those present would not go out without signing more subscription blanks. Mr. Blackman then took up the work of announcing subscriptions as received. The girls of the Motor Corps, and of the National League for Women's Service, then went through the audience making collections, and the announcements of the amounts came thick and fast. Over \$3,000,000 had been totaled when Caruso took the stage, and after his singing about \$1,000,000 more were turned in. There were prospects of some hundreds of thousands of dollars more to be garnered when Mr. Blackman called a halt close to midnight and asked that further subscriptions be sent to the headquarters of the committee.

From the viewpoint of patriotic fervor, for practical results, and for the caliber of the musical program, the rally proved most satisfactory and much credit is due the members of the Allied Music Division, and particularly the representatives of the talking machine industry connected therewith for their work in connec-

tion with the concert. The committee is as follows: Mark P. Campbell, chairman; J. Newcomb Blackman, vice-chairman; Charles Jacob, treasurer, and Albert Behning, secretary. The concert was under the direct supervision of C. G. Child, and a representative of the music and trade committee. Henry C. Brown directed the publicity, and Sherwood M. Hard staged the concert. Here it might be said that seldom have the stage and auditorium of Carnegie Hall been more elaborately decorated than on the night of the rally, when the national colors in stands and draperies were used in profusion.

AN INTERESTING ISSUE

October Number of the "Columbia Record" Has Many Selling Helps for Dealers

The October issue of the "Columbia Record," the house organ published monthly by the Columbia Graphophone Co., reached Columbia dealers this week, and this issue contains a number of selling helps that the dealers are utilizing to excellent advantage.

On the front page there are reproduced three photographs showing how moving picture theatres, rotary clubs and display windows are being used to feature the remarkable record made by General Pershing, which was recently announced by the Columbia Graphophone Co. On this page there are also several photographs of "Mickey," otherwise known as Mabel Normand, who will be featured in the photo play "Mickey," to be released shortly. Two special Columbia records will be introduced during the next few weeks featuring the music that has been specially written for this photo play.

On another page of this "Columbia Record" there is a list of some of the famous Columbia artists whose concert tours for the coming season will be inaugurated in the near future. The dealers are given the itineraries of these artists, in order that they may tie up their publicity effectively and efficiently with the concerts and recitals. There are also the usual number of advertising suggestions.

The BUSH & LANE Phonograph

We are making it a criterion of quality in Talking Machines

It's a remarkable *musical instrument*, that's what it is, of rich, sonorous, natural tone, *beautifully cased*.

You may well be proud to *show* the BUSH & LANE to your customers and prouder still to have them *hear* it.

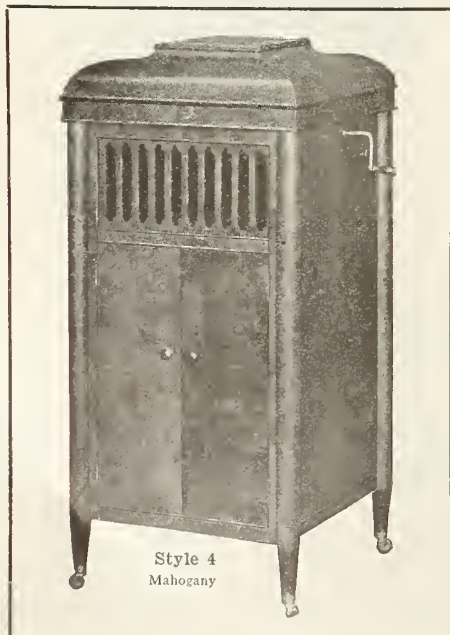

Style 4
Mahogany

It's not only a good all round, *absolutely high-grade machine*, but it has some *notable* and exclusive features—such as our *specially designed* and *rightly constructed* tone chamber, our own *graduating* modifier and other talking and result-producing points.

The BUSH & LANE is a *fully* satisfying machine for *everybody*, including the most severe and best posted critics.

WRITE FOR PICTORIAL AND TEXTUAL
INFORMATION OF THE COMPLETE LINE

BUSH & LANE PIANO CO.

HOLLAND, MICHIGAN

Lazaro—Barrientos—Stracciari—Baklanoff
—you'll be reading of their operatic
triumphs soon. So will your customers.

Columbia Graphophone Co.
NEW YORK



SEIDEL IS A COLUMBIA ARTIST

Celebrated Violinist to Make Records For Columbia Library Exclusively

G. C. Jell, general manager of the Columbia Graphophone Co.'s recording laboratories, announced this week that Toscha Seidel, the young violinist who is expected to be one of the foremost violinists of the present day, had been en-



Toscha Seidel

gaged to make records for the Columbia library exclusively. Mr. Seidel's first records will be announced in the very near future, and musical critics who have visited the Columbia laboratories during the past week are enthusiastic regarding their musical and sales possibilities.

Toscha Seidel, although only eighteen years of age, has been a student of the violin for many years. Since childhood he has been studying under Professor Leopold Auer, who has won international renown as the mentor of some of the world's most famous violinists. As a boy Toscha Seidel played in some of the leading cities in Continental Europe, where he was acclaimed as a prodigy.

Mr. Seidel appeared several times on the local concert stage last season, giving concerts at Carnegie Hall, which were attended by capacity audiences. His playing won the commendation of well-known critics, who were particularly impressed with his remarkable technique and the warmth of expression evidenced in his playing. A concert tour that will call for his appearance in the leading cities of this country will be inaugurated very shortly, and there is no doubt but that Mr. Seidel will be one of the most successful violinists on the concert stage this year.

His four Columbia records include selections

that thoroughly reflect Mr. Seidel's masterly art; among these numbers being Dvorak's "Humoresque" and Schumann's "Traumerei." An intensive campaign featuring Mr. Seidel's records will be introduced by the Columbia Co., which will co-operate with the dealers in announcing Mr. Seidel's records in their respective localities.

MICKEL BROS. CO. RED CROSS UNIT

Eighteen Feminine Members of Organization Engaged in Very Useful War Work

OMAHA, NEB., October 7.—Unique among the Red Cross Auxiliaries here is the unit made up of employes of Mickel Bros. Co., the Victor wholesalers, every member of which has a relative in the service. There are eighteen members in the Auxiliary, and they meet one evening each week. In addition to doing usual Red Cross work they are this year supporting four French orphans, and at the same time arranging to send Christmas boxes to the men of the Mickel Bros. organization in service.

Mrs. George E. Mickel and Mrs. T. L. Yard assist the girls in their work. Miss Mayme A. Jardine is chairman and the unit includes Mrs. John Gunn, Mrs. E. A. Miller, Mrs. Pauline Lynch, Mrs. O. M. Branson and Misses Esther Jacobsen, Eva Jacobsen, Honore Yard, Bess Greenberg, Sarah Givens, Eva Heffelfinger, Gwynthe Trothe, Josephine Cleaver, Effie Egert, Adalyn Solliday, Lucile Ellis, Alma Darling and Agnes Slaven.

ROBERT E. CLARK WITH Y. M. C. A.

Robert E. Clark, well-known Edison artist, is at present doing valuable work with the Y. M. C. A., as a musical director in the army camp in the Southeastern Military Department, and according to Y. M. C. A. officials is accomplishing wonderful results.

JAPANESE HAVE OWN TRADE PAPER

The Phonograph World Published in Tokyo Displays Some Excellent Yankee Ideas—The World Also Popular in Far East

The talking machine industry in Japan has a most substantial trade paper all its own, under the title of "The Phonograph World," copies of which have reached New York. Judging from the appearance of the columns, even though we do not read Japanese fluently, it would appear as though the talking machine men of the Flowery Kingdom are firm believers in advertising. There are also a plentiful number of illustrations, and a liberal supply of trade text in the fifty or more pages of the average number. Not the least interesting feature of a recent issue is the manner in which advertising illustrations from The Talking Machine World were used again by the Japanese after a native touch had been given to the costumes.

Incidentally it may be mentioned that The Talking Machine World has for many years enjoyed a wide circulation in Japan and other countries in the Far East, a fact that will be attested to by numerous advertisers who have received answers to their ads in The World from those countries.

DEMAND FOR RECORD RACKS

I. Davega, Jr., Inc., Victor wholesalers, 125 West 125th street, New York, have had remarkable success in the selling of their record racks. As a companion sales help for the demonstration booth they are now offering a record box divided in three parts, the first for records to be played, the second for those sold and the third for those rejected. The box has a capacity of twenty-four records and is already proving its value.



TEN INCH

Operaphone

PLAY WITH STEEL NEEDLE
 ON ALL UNIVERSAL TONE ARM MACHINES

Records

COMPLETE CATALOGUE SENT ON REQUEST

OPERAPHONE CO., INC., LONG ISLAND CITY, N. Y.



IMPORTANT NOTICE

TO THE AMERICAN TRADE

The Sterno Manufacturing Company
19 CITY ROAD LONDON, E. C. ENGLAND

Manufacturers of the world known COMPACTOPHONE—the most complete portable gramophone extant—beg to announce the conclusion of arrangements for the EXCLUSIVE SELLING RIGHTS IN THE UNITED STATES OF THE

High Grade Motors Manufactured By **Mermod Freres** St. Croix Switzerland

WONDERFUL MECHANISM

These motors represent the acme of workmanship and quality. Each part is made to the finest gauge limits and assembled to run with the precision of a watch—silent and true. Messrs. Mermod Freres is an old established Swiss manufacturer. Back of their motors are years of hard practical experience. The experimental stage was left behind a decade or more ago. Reliability and quality is therefore assured.

DIFFERENT MODELS

Mermod Freres motors comprise several types—single and double spring worm and pinion-gear drive, the very latest and scientific method of construction.

CONSULT US

Before placing your orders elsewhere consult us as to prices and terms of trading. We are out for quick shipments and prompt delivery direct from the factory to the buyer.

SPECIAL TERMS TO JOBBERS

Within the near future it is proposed to establish
A CENTRAL DISTRIBUTING DEPOT IN NEW YORK
Meanwhile trade enquiries should be directed to

THE STERNO MANUFACTURING CO.
19 CITY ROAD LONDON, E. C. ENGLAND

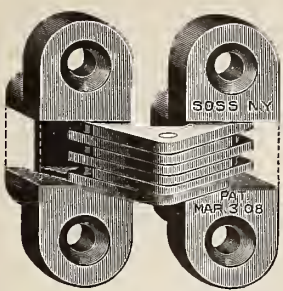

No. 103

SOSS

INVISIBLE HINGES

Preserve Beauty

In many beautifully designed, finely finished Talking Machines, Pianos, Music Cabinets, Piano Players and Benches, the elimination of the unsightly protruding Hinge is essential to preserve the beauty of the design.

Design and Construction

The fine cabinet work which is required in many instances to preserve the disguise of the instrument requires that the hinges be as inconspicuous as possible. SOSS Hinges are invisible.

WRITE FOR CATALOGUE "T"

SOSS MANUFACTURING COMPANY, 435 Atlantic Avenue, BROOKLYN, N. Y.

DETROIT—922 David Whitney Bldg. SAN FRANCISCO—164 Hansford Bldg.

LOS ANGELES—600 Metropolitan Bldg. CHICAGO—John C. Bold & Co., Clark and Washington Sts., Conway Bldg.

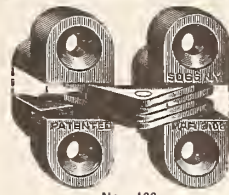

No. 100

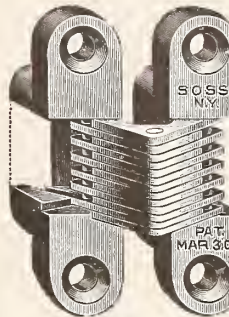

No. 101

SOME LIVE RECORD PUBLICITY

How the Local Dealers Are Featuring the New "OkeH" Records in Their Stores

The accompanying photographs will give some idea of the publicity being given the "OkeH" record by dealers handling this line. During the past few weeks the Otto Heineman



Display of Ridgely's Music House

Phonograph Supply Co., manufacturer of the "OkeH" record, has been advised by the dealers that this record is achieving signal success, and these window displays bear eloquent testimony to this fact.

C. E. Ridgley, who conducts a very successful musical instrument store at 1503 Third avenue, never handled any line of records prior to be-



Kraft's OkeH Window Display

coming interested in the "OkeH" record line. After listening to several of the new piano records included in the "OkeH" library, he gave the Otto Heineman Co. a substantial order, stating that he intended to exploit the line energetically this fall. This window display produced many sales of "OkeH" records, and Mr. Ridgley is enthusiastic regarding future possibilities for "OkeH" business.

Fred Kraft, who conducts establishments in the Hudson Terminal and in the Grand Central Terminal Concourse, is handling the "OkeH" record line in both of his stores. Mr. Kraft is well known in the retail talking machine field, and the fact that he has chosen the "OkeH" record for exploitation is a significant tribute to its selling powers.

SOME EDISON TONE TEST NEWS

Nearly 600 Recitals Already Booked by Edison Dealers for This Fall—A List of the Prominent Artists Who Are Giving Tone Tests

The unique series of recitals known as Edison tone tests are making a bigger hit this season than ever before. A total of 583 recitals have been booked for this fall. These, with the 1,742 previously given, make a total of 2,325 recitals which will have been given by this Christmas. This means that over two million people will have heard this convincing demonstration of the New Edison.

At present Miss Alcock is touring in Nebraska for Schultz Bros. Dalhart is favoring the St. Louis, New Orleans and Atlanta zones. The Ellerman-Seydel tour has finished four weeks near Pittsburgh and will be heard in Iowa and Minnesota until the holidays. Ellison has had to split up his time between five different zones. Madame Ferrell is on the Coast, after filling engagements in Iowa, Colorado and Utah. The charming Fleming Trio are spending twelve happy weeks with Harger & Blish, Edison jobbers at Des Moines and Sioux City.

Miss Gardner has been in Canada and Iowa and will finish her season in the Middle West shortly before Christmas.

Madame Le Fontenay opened in eastern Pennsylvania, after which she visits the Indianapolis and Omaha zones each for four weeks. Marie Morrissey covers New Brunswick, Canada, New England and central New York during a ten-week tour. Madame Rappold will give some big recitals in the South. Betsy Lane Shepherd is squeezing in eight weeks in the Middle West before going on a twenty-week concert tour of her own.

Marie Tiffany also gives eight weeks in the Richmond, Atlanta and Cincinnati zones before the opera season opens in November.

Alice Verlet started out in Idaho and works East via Des Moines, Chicago and Albany. Hardy Williamson favors New England.

A gratifying feature of the Edison tone test campaign is that the majority of dealers who once give recitals repeat. There are dealers who have booked as many as ten recitals since

the campaign opened three years ago. These dealers are located in various parts and in towns of varying size, and no one locality seems any more suited to the tone test than another.

RETURNS FROM EXTENDED TRIP

R. F. Bolton, Sales Manager of Columbia Co., Tells of Visit—Rosenblatt Records Popular

R. F. Bolton, sales manager of the Columbia Co.'s international record department, returned Monday from an extended trip which included a visit to the company's branches in Pittsburgh, Cleveland, Indianapolis, Chicago, Minneapolis, Omaha, Kansas City, Dallas, St. Louis and Cincinnati. At all of these branches Mr. Bolton conferred with the branch managers regarding international record business, and was gratified to learn that the sales totals for September showed a very substantial increase over last year.

The new Columbia records recently made by the Serbian Tambouritza Orchestra are meeting with an active sale everywhere, and Columbia dealers appreciate the fact that these records can be merchandised to splendid advantage through the use of effective sales arguments. Musically, the records made by the Serbian Tambouritza Orchestra have won considerable praise, and a new record by this organization will be released this month.

Columbia dealers handling the company's foreign-language records are taking a keen interest in the campaign that is being prepared in behalf of the records made by Cantor Joseph Rosenblatt. An artistic hanger featuring the records of this well-known cantor is now ready for distribution to the trade, and as Cantor Rosenblatt is starting an extended concert tour this month this hanger can be tied up very effectively with his tour. On November 20 a new Columbia record entitled "The Soldiers of Zion," sung by Cantor Rosenblatt, will be in the hands of Columbia representatives. The timely and patriotic character of this selection insures its hearty reception among lovers of this class of music.

For Foch and freedom, buy Liberty Bonds—then buy more of them.

"MAGNET" DECALCOMANIE NAMEPLATES FOR TALKING MACHINE CABINETS ETC. Pamphlets with fac-simile illustrations and prices mailed on request. SMITH-SCHIFFLIN CO. 126 Liberty Street New York City

TALKING MACHINE MEN, INC., AFTER JOBBER-RETAILERS

Following Suggestions Made at Regular Meeting Last Month, Resolutions Are Presented and Adopted at Special Session Asking That Retailing by Jobbers Be Stopped

September was a lively month for the Talking Machine Men, Inc., inasmuch as they not only held their regular meeting in the Assembly Rooms of the Merchants' Association in the Woolworth Building on September 18, but also held a special meeting and luncheon at the Cafe Boulevard on September 27, the latter for the purpose of introducing a resolution asking that steps be taken to persuade the jobbers to refrain from selling at retail during the period of the present shortage at least. At the regular meeting much attention was given to the letter sent out by one of the large talking machine manufacturers advising the trade that the output of machines would be cut down 50 per cent. or more below normal, and that there would also be a drop in record output. The dealers gave considerable thought to ways and means for overcoming this shortage in some manner.

Irwin Kurtz, M. Max and E. Leins were appointed a special committee to find ways and means of curbing price cutters, especially of the type who erase the numbers on talking machines, a particularly flagrant case of that sort being brought to the attention of the association in a recent police court trial. Some effort will again be made to have a law passed by the legislature applying to talking machines as it now applies to automobiles, in which it is a felony to mar, destroy or erase the distinguishing marks.

The committee is also authorized to publicly commend the work of a city detective who took a prominent part in bringing the above case to trial. M. Max was appointed a member of the executive committee of the association to succeed Max Landay, who recently resigned.

President Coughlin was authorized to represent the body on the Allied Music Committee for the Fourth Liberty Loan. A notification

has been forwarded to that organization informing them of Mr. Coughlin's appointment.

A letter was read from the secretary of the Tri-State Victor Dealers' Association in reply to a letter from the local body looking forward to forming a national association.

During the last year several efforts have been made to arrange some plan whereby dealers might readily exchange merchandise in which they were overstocked for other goods with which competitors might be burdened and in this way giving each other service to mutual advantage. Messrs. Kurtz, Max, Mielke and Lazarus were appointed to further plans to that effect.

Resolution Adopted at Special Meeting

At the special meeting and luncheon at the Cafe Boulevard on September 27 the local jobbers and dealers, together with representatives of the Philadelphia and Pittsburgh Dealers' Associations, and E. J. Dingley, manager of the order department of the Victor Co., were the guests of the Talking Machine Men, Inc. M. Max, manager of the talking machine department of Gimbel Bros., New York, was introduced by President Coughlin and presented the following resolution, after explaining the ideas of the retailers in presenting it.

Mr. Max explained that the shortage of stock has become so serious that the dealers viewed with alarm the fact that the jobbers could sidetrack part of the supply to their own retail departments and be frequently able thereby to offer machines and records that the dealer could not obtain. The resolution as introduced read:

"Resolved, That the Victor Talking Machine Co. of Camden, N. J., has at all times dealt fairly and justly with the jobbers and the dealers in its product and has at all times shown its equitable spirit of dealing.

"And, whereas, By the written statement of

the 13th inst. issued by its officers in which it approved the action of our Government in curtailing all industries except those deemed to be essential in the winning of the war in which it is engaged, the company has thus evidenced its spirit of patriotism which is unanimously approved by members of the Talking Machine Men, Inc., and as we believe by all patriots of this nation.

"Whereas, Though such action curtails its output, we believe it sends forth its best efforts to produce the greatest quantity of machines and records and is using its best methods to equitably distribute its product to all the jobbers in the product, who should deliver it equitably to retail dealers therein.

"Whereas, It is alleged that some of the jobbers without the sanction of the Victor Talking Machine Co. have taken the product thus delivered and instead of distributing it to the retail dealers in equitable shares, use the same by retailing it, unwarrantedly, to their own advantage, thus because of the difference in discounts taking an unfair advantage of the "regular" dealer, to whom the jobber should deliver the required merchandise when equitably required to do so; if that were done it would thus give the splendid Victor product a better opportunity to become still more popular, by its broader distribution; thus resulting in an advantage to the Victor Company, to the jobbers and the dealers therein.

"Resolved, That the Talking Machine Men, Inc., desire it to be distinctly understood that the strength of its recommendation lies in its fairness, in disapproving of the retailing of the Victor product by the jobbers therein and recommend to the Victor Talking Machine Co. that such measures as are equitable and necessary to protect the rights of the retail dealers in the Victor product be made effective as soon as may be consistent with fairness to all persons interested therein.

"Resolved, That a copy of this resolution be forwarded to the Victor Talking Machine Co. of Camden, N. J., for its consideration and action thereon."

During the course of the discussion there was a lively tilt between a well-known jobber and dealer over the charge of the latter that one of his customers had asked for a certain popular record, and that upon being told that the dealer was unable to obtain it, made a bet with him that the record could be obtained in some other store. He stated that the customer went to the jobber's retail department and secured six records of the desired title. The jobber appeared at luncheon in his own defense, and held that inasmuch as the dealer was not on his list there was no discrimination shown in the fact that he was unable to get those particular records from that particular jobber.

A member of the executive committee hastened to explain that the resolution was not based upon any specific charge made against the jobber by any dealer, but had been thought out long before such cases came up before the association.

Several jobbers and dealers discussed briefly the question of the jobber acting also as retailer, after which Edward J. Dingley, manager of the order department of the Victor Talking Machine Co., was introduced and discussed the situation simply as it referred to the Victor output of machines and records. Mr. Dingley declared that the resolution had to go to the directors of the Victor Co. for final action, and pointed out that much of the early development of the Victor business was due to the support of such jobbing organizations as Sherman, Clay & Co., the J. W. Jenkins' Sons Co., Lyon & Healy, and other concerns of like caliber, who also acted as dealers.

The adoption of the resolution as originally drafted ended the discussion, and the final results will be awaited with interest.

The Cromwell Music Co., Siloam, Ark., has taken over the Edison phonograph agency from the Benton County Hardware Co., which plans to feature that line in a big way.

THE PARR CENTRAL UNIVERSAL TONE-ARM

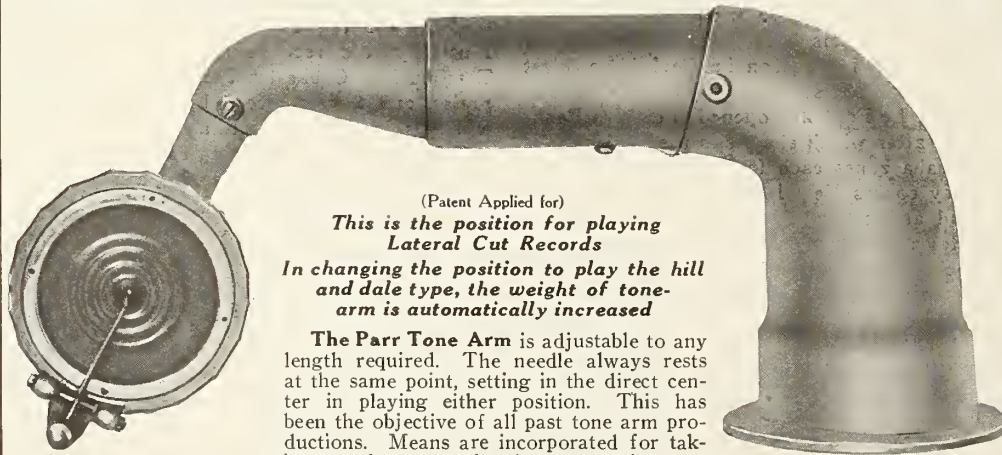

(Patent Applied for)

This is the position for playing Lateral Cut Records

In changing the position to play the hill and dale type, the weight of tone-arm is automatically increased

The Parr Tone Arm is adjustable to any length required. The needle always rests at the same point, setting in the direct center in playing either position. This has been the objective of all past tone arm productions. Means are incorporated for taking up the wear, thereby overcoming any

tendency for loose joints, which is the chief cause of "chattering."

The design of the tone arm permits perfect playing of either type of record without additional attachments. The sound box can be turned, allowing the needle to be changed with ease, and by a reverse movement the box returns to its normal playing position.

Parr Magnetic Reproducer fitted with the Vibratone Patent Diaphragm

The most sensitive of reproducers. The permanent magnetic device, an integral part of the reproducer, acts on the stylus box. Its possibilities in giving warmth and delicacy in the tonal reproduction of quiet passages make old-style sound boxes seem obsolete. And in fortissimo passages where ordinary reproducers create unpleasant, music destroying blasts, caused by the needle jumping and losing its grip, the Parr Magnetic Reproducer, with its marvelous flexibility, follows every wave and vibration in the record and takes everything the record holds.

The indestructible, non-crystallizing, always resilient **Vibratone Patented Diaphragm**

Possessing all the good points of mica diaphragms, it overcomes all mica's bad features. Guaranteed uniform in quality, free from bubbles, blisters and waves, the Vibratone Patented Diaphragm is non-porous, non-absorbent.

It has a definite function and it performs it. It improves tone; in fact it creates new tone possibilities for every reproducer of other types.

PARR MANUFACTURING CORP.
ONE UNION SQUARE - - - NEW YORK



SUBSCRIBE \$406,000 AT LUNCHEON

Allied Music Committee Fourth Liberty Loan Keeps Up Its Good Work—J. N. Blackman Urges That Everybody Buy to the Limit and Then Borrow to Buy Some More

A meeting and luncheon of the Allied Music Division Fourth Liberty Loan was held at the Hotel McAlpin on Tuesday, October 8, and was attended by practically all chairmen, vice-chairmen and captains making up the general committee. Chairman Mark P. Campbell made a most encouraging report of what had already been accomplished before, at and since the great rally at Carnegie Hall, and those in charge of the various trade and professional divisions also reported what progress had been made to date.

One of the speakers was Morris K. Parker, in charge of the work of the Rainbow Division for the Liberty Loan Committee, who told of the task that faced the division, and for that matter the country at large in going over the top with the loan.

J. Newcomb Blackman, vice-chairman, gave an inspiring talk, during the course of which he urged that everyone in the trade plunge to the limit in buying the bonds, and advised that those who had reached the limit of their cash resources should apply to their bank, and learn of the plans made by the bankers for loaning money with which to make Liberty Bond investments.

In order to keep the spirits from flagging it was suggested that the members of the committee at the luncheon should subscribe again on their own account, the result being that \$406,000 was subscribed by those around the table in a comparatively short space of time. It was also announced at the meeting that Gall-Curci, in addition to donating her services at the rally, thereby contributing in no small part to its success, had also subscribed through the Allied Music Committee for \$20,000 in bonds, and that other artists had also made generous subscriptions.

DAILY RECITALS AT EDISON SHOP

Winter Schedule Now Resumed—Helping Loan Drive on Fifth Avenue

Edward C. Boykin, manager of the Edison Fifth avenue retail showrooms, New York, reports exceptional sales during the past month. The daily recitals which have been resumed are being well attended.

During the Fourth Liberty Loan drive a figure of a traffic officer was placed on the sidewalk in front of the building. The figure was life-sized and operated one of the familiar traffic-regulating devices which read "Stop, Buy Liberty Bonds."

"CHARMAPHONE" MAKES ITS DEBUT

The R. L. Kenyon Mfg. Co., Mexico, N. Y., has just placed on the market a complete line of machines which will be merchandised as the "Charmaphone" talking machine. At the present time the line consists of five models, including two table and three floor cabinets.

The "Charmaphone" is equipped with a Universal tone arm, playing all makes of records, and the R. L. Kenyon Co. has paid particular attention to the cabinet work on these instruments. The company has delayed announcing this new machine in order to be in a position to supply its dealers with prompt deliveries, and at the present time is able to take care of the demands of its clientele for fall and holiday business.

H. J. SMITH—Jewel Manufacturer

MANUFACTURER OF—Phonograph Diamond and Sapphire Reproducing Points—Recording Laboratory Jewels—Jewel Bearings for Electrical Instruments—Rough Diamond—Diamond Powder—Experimental Work.

Telephone 2896 Market

833 BROAD STREET NEWARK, N. J.

OFFER NEW MACHINE-CABINET UNITS

Geo. A. Long Cabinet Co. Introduces Interesting Innovation to the Trade

The George A. Long Cabinet Co., Hanover, Pa., has just issued to the trade a new and interesting combination of machine and cabinet in two styles, both so designed that the machine and cabinet fit together perfectly and have the appearance of a single unit, thus carrying out the primary purpose intended. This is the first venture of the George A. Long Co. in the machine field, and has been made according to officers of the company with a view to meeting the demand of those people who desire a small machine and also a cabinet that would match it perfectly.

The specifications of the new instrument, together with wholesale prices, are to be found in the Long Co.'s ad on another page of The Talking Machine World this month.

The company has also announced a new style record cabinet made in mahogany, golden oak and other finishes, and which has been designed to fit a new type of machine shortly to be

marketed by one of the prominent companies. In this connection they have issued a very interesting folder which dealers should write for.

G. W. LYLE OFF TO PACIFIC COAST

George W. Lyle, assistant to the president of the Pathé Frères Phonograph Co., Brooklyn, N. Y., left Monday for a month's trip to the Pacific Coast. Mr. Lyle will visit the Pathé jobbers en route, and judging from the splendid business being closed by the Pathé dealers he will receive excellent reports of the business situation in the different cities he visits.

SECURE AEOLIAN-VOCALION AGENCY

PHILADELPHIA, Pa., October 7.—Gimbel Bros., who have secured the representation here of the Aeolian-Vocalion, and are advertising it extensively, are doing a very good business. They are the first of the firms here to handle this fine instrument. They are demonstrating it on the first floor of their store, as well as in the talking machine department, which is located on the seventh floor.

STICK TO YOUR TRENCH

LIKE THE BOYS AT THE FRONT

STICK TO YOUR TRENCH

Remember, you've got to stick to your trench—
Yes, stick like glue to your trench.
You dig while it's dark, and you work while it's light,
And then there's the "listening post" at night.
Though you're soaked to the skin and chilled to the bone;
Though your hands are like ice, and your feet like stone;
Though your watch is long, and your rest is brief,
And you pray like hell for the next relief;
Though the wind may howl, and the rain may drench,
Remember, you've got to stick to your trench—
Yes, stick like mud to your trench.

There's a rush and a dash, and they're at your wire,
And you open the hell of a rapid fire;
The Maxims rattle, the rifles flash;
And the bombs explode with a sickening crash.
You give them lead, and you give them steel,
Till at last they waver, and turn, and reel.
You've done your job—there was never a blench
You've given them Hell, and you've saved your trench;
BY GOD, YOU'VE STUCK TO YOUR TRENCH!

CAPT. C. W. BLACKALL,
(Fighting in France).

FIGHT TO A FINISH

SELFISHNESS — INDIFFERENCE — OVER CONFIDENCE

We CAN and MUST "Stick to our trenches," at home, by buying LIBERTY BONDS until the last drop of our financial blood is given. Then when our fighting heroes return they can say: "By God, you've stuck to your trench."

BUY LIBERTY BONDS
and HOLD THEM



Blackman
TALKING MACHINE CO.

97 CHAMBERS ST. NEAR CHURCH ST. NEW YORK

Victor Distributors



The Windsor
Phonograph

Is the Personification of

Phonograph Distinction



MUSIC

IN

ART

ART

IN

MUSIC

DON'T BUY INFRINGEMENTS THIS TYPE OF PHONOGRAPH CABINET IS PATENTED

*The Windsor Phonograph Cabinet is now Protected by U. S. Patent
Issued September 24th, 1918*

A complete line of Period Styles and Upright Models playing all disc records

WRITE FOR A CATALOG

The Windsor Furniture Co.

1420 CARROLL AVE.

CHICAGO, ILL.

EXPRESS RATE INCREASE PLANNED

McAdoo Approves Increase to Produce Nearly \$24,000,000 Per Year—Hearing on October 8

Director General McAdoo has approved the application of the American Railway Express Co. for a rate increase sufficient to yield \$23,670,000 a year, and sent the application to the Interstate Commerce Commission for final action. Public hearings on the matter began on Tuesday, October 8.

A recent advance in the rates realized \$10,000,000 a year which, it was announced, had been absorbed in increasing wages. Mr. McAdoo was sure that \$12,000,000 additional revenue would be necessary. He said the express business was being conducted at a loss, which has been borne by the Railroad Administration. He has asked the Interstate Commission to take speedy action on the matter.

Public Service Commissioner Travis H. Whitney, as a member of the Special War Committee of the State Utilities Commissioners, said the committee had made a strong protest against the increase in rates, but that it was clear before he left Washington the increase would be made.

FORMAL "OPENING" A SUCCESS

The recent formal "opening" of the new talking machine department in the Meiklejohn store in Providence, R. I., was a tremendous success. This establishment, which was described in a previous issue of The World, is one of the most complete in Rhode Island, and under the management of Mr. Longfellow promises to be one of the successful establishments in that section.

The Victor department of the Dunlap store in Belvidere, Ill., has been bought out by the Talking Machine Co., of Rockford.

The Michigan Furniture Co., Youngstown, O., has taken the agency for the Pathé line.

FOUR RULES FOR GREATER PERSONAL EFFECTIVENESS

I

If you would increase your service-rendering power, you must know yourself, through self-analysis, and having become acquainted with the service-rendering qualities possessed by you, you must so nourish them and use them that they will unfold or develop.

II

If you would increase your service-rendering power, you must become a good judge of human nature.

III

If you would increase your service-rendering power, you must know your business, and come to know it through and through.

IV

If you would increase your service-rendering power, you must so apply your developed service-rendering qualities, your knowledge of human nature and your knowledge of your business, that you will create in the minds of those with whom you deal or come in contact the effects of favorable attention, interest, desire, action, confidence and satisfaction.

HOWARD ELLIOTT.

HOW TO HELP DISABLED SOLDIERS

The Red Cross Institute for Crippled and Disabled Men, 11 Fourth avenue, New York, would be glad to hear from manufacturers who desire to co-operate in placing war veterans who have been wounded in some form and who cannot fight, in useful manufacturing fields. The talking machine industry can help by using these men in its factories, and it would be well to get in touch with this organization as soon as possible.

WAR EXCISE TAXES ARE CUT IN HALF

Senate Finance Committee Reduces Taxes on Talking Machines and Records to 5 Per Cent.—Exemption of Pianos Causes Feeling

WASHINGTON, D. C., October 10.—The Senate Finance Committee in its consideration of the various sections of the proposed new War Revenue bill as presented by the House took up yesterday Section 900, placing taxes upon musical instruments of various sorts. Heeding the various arguments put before it the committee reduced the proposed excise tax on graphophones, phonographs, talking machines and records to 5 per cent. in place of the 10 per cent. proposed by the House, and at the same time made tax free pianos and pipe organs on the plea that they were used by churches, missions and Sunday schools.

It appears that, although the talking machine interests are somewhat pleased over the fact that the proposed tax on machines and records has been cut in half, they are still disappointed over the fact that the tax has been placed only on piano players and that pianos would then get off scot free of tax, as was the case in the first bill. It is the claim of the talking machine men that by taxing all musical instruments no discrimination will be shown and the burden would be lightened on each section of the industry.

At the present time no details are available regarding the action taken on Section 909, providing for a floor tax of 10 per cent. on the musical instruments covered by war excise taxes, although it is the understanding that the floor taxes have also been cut in half, or down to 5 per cent.

E. P. Northbutt has sold his taking machine business in Walton, Ky., and opened a new store in the suburb of Cincinnati, O., which will be completely equipped.

A TIMELY OFFERING

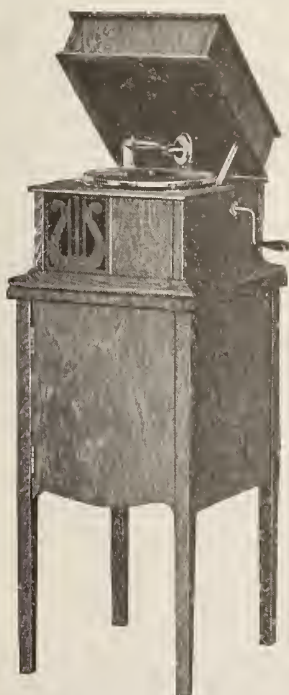

Model 1750-A

Golden Oak and Mahogany Finish only.

Dimensions 15½ x 17½
42 inches High

Price \$17.50 Net Cash
FOB Factory, plus War Tax.

HERETOFORE it has been a very serious problem for the Dealer to secure the smaller types of machines with the proper sort of disc record cabinet to make the outfit look like a complete floor type machine.

We have solved the problem, and offer the two types shown. Each outfit is offered complete as shown—Machine and Cabinet.

Specifications of Mechanical Equipment:

Powerful Double Spring Motor (Markels M-2). Plays three 10-inch records without rewinding. Worm Drive, Gray Fibre Gear. 10-inch Felt Covered Turntable, with Stop and Speed Regulator. Universal Tonearm.

Orders will not be accepted for less than ten complete outfits in proportions of 3 Mahogany finish and 7 Golden Oak.

Shipments will be made according to date of receipt of order.

Place your orders NOW.

The Geo. A. Long Cabinet Company
Hanover, Pa.



Model 1500-A

Golden Oak and Mahogany Finish only.

Dimensions 15½ x 17½
39 inches High

Price \$15.00 Net Cash
FOB Factory, plus War Tax

HOLD THEIR ANNUAL MEETINGS

Sonora Phonograph Corp. and Sonora Phonograph Sales Co. Elect Officers for Year

The Sonora Phonograph Corp. recently held its annual meeting of directors at which the following officers were re-elected for the ensuing year: George E. Brightson, president and treasurer; J. N. Beach, vice-president; Joseph Wolff, secretary; W. J. Farquhar, assistant treasurer; W. Varrin, comptroller. The directors for the coming year are the same as during the past fiscal year, being J. N. Beach, George E. Brightson, H. P. Chilton, Waldo G. Morse and Joseph Wolff.

The Sonora Phonograph Sales Co., Inc., also held its annual meeting recently and the following officers were elected: George E. Brightson, president; Lewis Cruger Hasell, vice-president; Joseph Wolff, treasurer; E. H. Jennings, secretary and assistant treasurer; J. T. Pringle, comptroller, and Frank J. Coupe, manager sales and advertising. The only change in this list of officers is the election of Mr. Jennings as secretary, succeeding J. Schechter, who resigned. Mr. Jennings was formerly assistant treasurer of the company and occupies the position of secretary in addition to his other duties.

The following directors were elected for the ensuing year: George E. Brightson, John A. Eckert, L. C. Hasell, Waldo G. Morse, Joseph W. Stinson, Joseph Wolff and Frank J. Coupe. The only change in the board of directors is the election of Mr. Coupe, who succeeds J. Schechter. Mr. Coupe is one of the most popular members of the talking machine industry, and the remarkable success he has achieved as manager of sales and advertising for the Sonora Phonograph Sales Co. has been recognized by the company in his election as a director.

A LOSS TO THE INDUSTRY

In a recent chat with a representative of The World regarding general conditions in the talking machine industry George E. Brightson, president of the Sonora Phonograph Corp., commented upon the great loss to the industry that was occasioned by the recent resignation of Louis F. Geissler as general manager of the Victor Co. Mr. Brightson stated that he firmly believed that the industry as a whole will suffer a severe loss as a result of Mr. Geissler's decision to take a less active interest in business affairs in the future.

CAPT. HASTINGS SENDS MESSAGE

Capt. Thomas W. Hastings, of New York, formerly connected with the Pease Piano Co., and likewise member of the Talking Machine Men, Inc., was one of the American officers on the firing lines in France who sent back through Lincoln Eyre, the New York World war correspondent, messages urging the liberal buying of Fourth Liberty Bonds in this country.

TRADE MARK
BEE CROFT



Record Cabinets

Made by
Nanes Art Furniture Co.
New York City

Record Envelopes



PIANO CREAM

is wonderful for restoring the lustre
to Talking Machines

Thirty desirable records. You may not have all of these selections
We will gladly play any record for you.

INSTRUMENTAL		VOCAL - Continued	
4001 (Special Records) "The King of Phoenicians" (Instrumental) 25	4002 (Special Records) "The King of Phoenicians" (Instrumental) 25	4003 (Special Records) "The King of Phoenicians" (Instrumental) 25	4004 (Special Records) "The King of Phoenicians" (Instrumental) 25
4005 (Special Records) "The King of Phoenicians" (Instrumental) 25	4006 (Special Records) "The King of Phoenicians" (Instrumental) 25	4007 (Special Records) "The King of Phoenicians" (Instrumental) 25	4008 (Special Records) "The King of Phoenicians" (Instrumental) 25
4009 (Special Records) "The King of Phoenicians" (Instrumental) 25	4010 (Special Records) "The King of Phoenicians" (Instrumental) 25	4011 (Special Records) "The King of Phoenicians" (Instrumental) 25	4012 (Special Records) "The King of Phoenicians" (Instrumental) 25
4013 (Special Records) "The King of Phoenicians" (Instrumental) 25	4014 (Special Records) "The King of Phoenicians" (Instrumental) 25	4015 (Special Records) "The King of Phoenicians" (Instrumental) 25	4016 (Special Records) "The King of Phoenicians" (Instrumental) 25
4017 (Special Records) "The King of Phoenicians" (Instrumental) 25	4018 (Special Records) "The King of Phoenicians" (Instrumental) 25	4019 (Special Records) "The King of Phoenicians" (Instrumental) 25	4020 (Special Records) "The King of Phoenicians" (Instrumental) 25
4021 (Special Records) "The King of Phoenicians" (Instrumental) 25	4022 (Special Records) "The King of Phoenicians" (Instrumental) 25	4023 (Special Records) "The King of Phoenicians" (Instrumental) 25	4024 (Special Records) "The King of Phoenicians" (Instrumental) 25
4025 (Special Records) "The King of Phoenicians" (Instrumental) 25	4026 (Special Records) "The King of Phoenicians" (Instrumental) 25	4027 (Special Records) "The King of Phoenicians" (Instrumental) 25	4028 (Special Records) "The King of Phoenicians" (Instrumental) 25
4029 (Special Records) "The King of Phoenicians" (Instrumental) 25	4030 (Special Records) "The King of Phoenicians" (Instrumental) 25	4031 (Special Records) "The King of Phoenicians" (Instrumental) 25	4032 (Special Records) "The King of Phoenicians" (Instrumental) 25
4033 (Special Records) "The King of Phoenicians" (Instrumental) 25	4034 (Special Records) "The King of Phoenicians" (Instrumental) 25	4035 (Special Records) "The King of Phoenicians" (Instrumental) 25	4036 (Special Records) "The King of Phoenicians" (Instrumental) 25
4037 (Special Records) "The King of Phoenicians" (Instrumental) 25	4038 (Special Records) "The King of Phoenicians" (Instrumental) 25	4039 (Special Records) "The King of Phoenicians" (Instrumental) 25	4040 (Special Records) "The King of Phoenicians" (Instrumental) 25
4041 (Special Records) "The King of Phoenicians" (Instrumental) 25	4042 (Special Records) "The King of Phoenicians" (Instrumental) 25	4043 (Special Records) "The King of Phoenicians" (Instrumental) 25	4044 (Special Records) "The King of Phoenicians" (Instrumental) 25
4045 (Special Records) "The King of Phoenicians" (Instrumental) 25	4046 (Special Records) "The King of Phoenicians" (Instrumental) 25	4047 (Special Records) "The King of Phoenicians" (Instrumental) 25	4048 (Special Records) "The King of Phoenicians" (Instrumental) 25
4049 (Special Records) "The King of Phoenicians" (Instrumental) 25	4050 (Special Records) "The King of Phoenicians" (Instrumental) 25	4051 (Special Records) "The King of Phoenicians" (Instrumental) 25	4052 (Special Records) "The King of Phoenicians" (Instrumental) 25
4053 (Special Records) "The King of Phoenicians" (Instrumental) 25	4054 (Special Records) "The King of Phoenicians" (Instrumental) 25	4055 (Special Records) "The King of Phoenicians" (Instrumental) 25	4056 (Special Records) "The King of Phoenicians" (Instrumental) 25
4057 (Special Records) "The King of Phoenicians" (Instrumental) 25	4058 (Special Records) "The King of Phoenicians" (Instrumental) 25	4059 (Special Records) "The King of Phoenicians" (Instrumental) 25	4060 (Special Records) "The King of Phoenicians" (Instrumental) 25
4061 (Special Records) "The King of Phoenicians" (Instrumental) 25	4062 (Special Records) "The King of Phoenicians" (Instrumental) 25	4063 (Special Records) "The King of Phoenicians" (Instrumental) 25	4064 (Special Records) "The King of Phoenicians" (Instrumental) 25
4065 (Special Records) "The King of Phoenicians" (Instrumental) 25	4066 (Special Records) "The King of Phoenicians" (Instrumental) 25	4067 (Special Records) "The King of Phoenicians" (Instrumental) 25	4068 (Special Records) "The King of Phoenicians" (Instrumental) 25
4069 (Special Records) "The King of Phoenicians" (Instrumental) 25	4070 (Special Records) "The King of Phoenicians" (Instrumental) 25	4071 (Special Records) "The King of Phoenicians" (Instrumental) 25	4072 (Special Records) "The King of Phoenicians" (Instrumental) 25
4073 (Special Records) "The King of Phoenicians" (Instrumental) 25	4074 (Special Records) "The King of Phoenicians" (Instrumental) 25	4075 (Special Records) "The King of Phoenicians" (Instrumental) 25	4076 (Special Records) "The King of Phoenicians" (Instrumental) 25
4077 (Special Records) "The King of Phoenicians" (Instrumental) 25	4078 (Special Records) "The King of Phoenicians" (Instrumental) 25	4079 (Special Records) "The King of Phoenicians" (Instrumental) 25	4080 (Special Records) "The King of Phoenicians" (Instrumental) 25
4081 (Special Records) "The King of Phoenicians" (Instrumental) 25	4082 (Special Records) "The King of Phoenicians" (Instrumental) 25	4083 (Special Records) "The King of Phoenicians" (Instrumental) 25	4084 (Special Records) "The King of Phoenicians" (Instrumental) 25
4085 (Special Records) "The King of Phoenicians" (Instrumental) 25	4086 (Special Records) "The King of Phoenicians" (Instrumental) 25	4087 (Special Records) "The King of Phoenicians" (Instrumental) 25	4088 (Special Records) "The King of Phoenicians" (Instrumental) 25
4089 (Special Records) "The King of Phoenicians" (Instrumental) 25	4090 (Special Records) "The King of Phoenicians" (Instrumental) 25	4091 (Special Records) "The King of Phoenicians" (Instrumental) 25	4092 (Special Records) "The King of Phoenicians" (Instrumental) 25
4093 (Special Records) "The King of Phoenicians" (Instrumental) 25	4094 (Special Records) "The King of Phoenicians" (Instrumental) 25	4095 (Special Records) "The King of Phoenicians" (Instrumental) 25	4096 (Special Records) "The King of Phoenicians" (Instrumental) 25
4097 (Special Records) "The King of Phoenicians" (Instrumental) 25	4098 (Special Records) "The King of Phoenicians" (Instrumental) 25	4099 (Special Records) "The King of Phoenicians" (Instrumental) 25	4100 (Special Records) "The King of Phoenicians" (Instrumental) 25
4101 (Special Records) "The King of Phoenicians" (Instrumental) 25	4102 (Special Records) "The King of Phoenicians" (Instrumental) 25	4103 (Special Records) "The King of Phoenicians" (Instrumental) 25	4104 (Special Records) "The King of Phoenicians" (Instrumental) 25
4105 (Special Records) "The King of Phoenicians" (Instrumental) 25	4106 (Special Records) "The King of Phoenicians" (Instrumental) 25	4107 (Special Records) "The King of Phoenicians" (Instrumental) 25	4108 (Special Records) "The King of Phoenicians" (Instrumental) 25
4109 (Special Records) "The King of Phoenicians" (Instrumental) 25	4110 (Special Records) "The King of Phoenicians" (Instrumental) 25	4111 (Special Records) "The King of Phoenicians" (Instrumental) 25	4112 (Special Records) "The King of Phoenicians" (Instrumental) 25
4113 (Special Records) "The King of Phoenicians" (Instrumental) 25	4114 (Special Records) "The King of Phoenicians" (Instrumental) 25	4115 (Special Records) "The King of Phoenicians" (Instrumental) 25	4116 (Special Records) "The King of Phoenicians" (Instrumental) 25
4117 (Special Records) "The King of Phoenicians" (Instrumental) 25	4118 (Special Records) "The King of Phoenicians" (Instrumental) 25	4119 (Special Records) "The King of Phoenicians" (Instrumental) 25	4120 (Special Records) "The King of Phoenicians" (Instrumental) 25
4121 (Special Records) "The King of Phoenicians" (Instrumental) 25	4122 (Special Records) "The King of Phoenicians" (Instrumental) 25	4123 (Special Records) "The King of Phoenicians" (Instrumental) 25	4124 (Special Records) "The King of Phoenicians" (Instrumental) 25
4125 (Special Records) "The King of Phoenicians" (Instrumental) 25	4126 (Special Records) "The King of Phoenicians" (Instrumental) 25	4127 (Special Records) "The King of Phoenicians" (Instrumental) 25	4128 (Special Records) "The King of Phoenicians" (Instrumental) 25
4129 (Special Records) "The King of Phoenicians" (Instrumental) 25	4130 (Special Records) "The King of Phoenicians" (Instrumental) 25	4131 (Special Records) "The King of Phoenicians" (Instrumental) 25	4132 (Special Records) "The King of Phoenicians" (Instrumental) 25
4133 (Special Records) "The King of Phoenicians" (Instrumental) 25	4134 (Special Records) "The King of Phoenicians" (Instrumental) 25	4135 (Special Records) "The King of Phoenicians" (Instrumental) 25	4136 (Special Records) "The King of Phoenicians" (Instrumental) 25
4137 (Special Records) "The King of Phoenicians" (Instrumental) 25	4138 (Special Records) "The King of Phoenicians" (Instrumental) 25	4139 (Special Records) "The King of Phoenicians" (Instrumental) 25	4140 (Special Records) "The King of Phoenicians" (Instrumental) 25
4141 (Special Records) "The King of Phoenicians" (Instrumental) 25	4142 (Special Records) "The King of Phoenicians" (Instrumental) 25	4143 (Special Records) "The King of Phoenicians" (Instrumental) 25	4144 (Special Records) "The King of Phoenicians" (Instrumental) 25
4145 (Special Records) "The King of Phoenicians" (Instrumental) 25	4146 (Special Records) "The King of Phoenicians" (Instrumental) 25	4147 (Special Records) "The King of Phoenicians" (Instrumental) 25	4148 (Special Records) "The King of Phoenicians" (Instrumental) 25
4149 (Special Records) "The King of Phoenicians" (Instrumental) 25	4150 (Special Records) "The King of Phoenicians" (Instrumental) 25	4151 (Special Records) "The King of Phoenicians" (Instrumental) 25	4152 (Special Records) "The King of Phoenicians" (Instrumental) 25
4153 (Special Records) "The King of Phoenicians" (Instrumental) 25	4154 (Special Records) "The King of Phoenicians" (Instrumental) 25	4155 (Special Records) "The King of Phoenicians" (Instrumental) 25	4156 (Special Records) "The King of Phoenicians" (Instrumental) 25
4157 (Special Records) "The King of Phoenicians" (Instrumental) 25	4158 (Special Records) "The King of Phoenicians" (Instrumental) 25	4159 (Special Records) "The King of Phoenicians" (Instrumental) 25	4160 (Special Records) "The King of Phoenicians" (Instrumental) 25
4161 (Special Records) "The King of Phoenicians" (Instrumental) 25	4162 (Special Records) "The King of Phoenicians" (Instrumental) 25	4163 (Special Records) "The King of Phoenicians" (Instrumental) 25	4164 (Special Records) "The King of Phoenicians" (Instrumental) 25
4165 (Special Records) "The King of Phoenicians" (Instrumental) 25	4166 (Special Records) "The King of Phoenicians" (Instrumental) 25	4167 (Special Records) "The King of Phoenicians" (Instrumental) 25	4168 (Special Records) "The King of Phoenicians" (Instrumental) 25
4169 (Special Records) "The King of Phoenicians" (Instrumental) 25	4170 (Special Records) "The King of Phoenicians" (Instrumental) 25	4171 (Special Records) "The King of Phoenicians" (Instrumental) 25	4172 (Special Records) "The King of Phoenicians" (Instrumental) 25
4173 (Special Records) "The King of Phoenicians" (Instrumental) 25	4174 (Special Records) "The King of Phoenicians" (Instrumental) 25	4175 (Special Records) "The King of Phoenicians" (Instrumental) 25	4176 (Special Records) "The King of Phoenicians" (Instrumental) 25
4177 (Special Records) "The King of Phoenicians" (Instrumental) 25	4178 (Special Records) "The King of Phoenicians" (Instrumental) 25	4179 (Special Records) "The King of Phoenicians" (Instrumental) 25	4180 (Special Records) "The King of Phoenicians" (Instrumental) 25
4181 (Special Records) "The King of Phoenicians" (Instrumental) 25	4182 (Special Records) "The King of Phoenicians" (Instrumental) 25	4183 (Special Records) "The King of Phoenicians" (Instrumental) 25	4184 (Special Records) "The King of Phoenicians" (Instrumental) 25
4185 (Special Records) "The King of Phoenicians" (Instrumental) 25	4186 (Special Records) "The King of Phoenicians" (Instrumental) 25	4187 (Special Records) "The King of Phoenicians" (Instrumental) 25	4188 (Special Records) "The King of Phoenicians" (Instrumental) 25
4189 (Special Records) "The King of Phoenicians" (Instrumental) 25	4190 (Special Records) "The King of Phoenicians" (Instrumental) 25	4191 (Special Records) "The King of Phoenicians" (Instrumental) 25	4192 (Special Records) "The King of Phoenicians" (Instrumental) 25
4193 (Special Records) "The King of Phoenicians" (Instrumental) 25	4194 (Special Records) "The King of Phoenicians" (Instrumental) 25	4195 (Special Records) "The King of Phoenicians" (Instrumental) 25	4196 (Special Records) "The King of Phoenicians" (Instrumental) 25
4197 (Special Records) "The King of Phoenicians" (Instrumental) 25	4198 (Special Records) "The King of Phoenicians" (Instrumental) 25	4199 (Special Records) "The King of Phoenicians" (Instrumental) 25	4200 (Special Records) "The King of Phoenicians" (Instrumental) 25

CLEMET BEECROFT 309 W. Susquehanna Ave.
PHILADELPHIA

"READY FILES" FOR RECORDS

EDISON FORCES HELPING LOAN

Taking Active Part in Making the Fourth Liberty Loan a Success

Thomas A. Edison, Inc., have been taking an active part in the Fourth Liberty Loan campaign. The three previous loans have been enthusiastically supported by every member of the Edison organization, and now that the Fourth Loan is being subscribed the Edison forces are doing their utmost to put it over the top. At the Edison factories in Orange, N. J., the campaign has been carried on by means of special meetings, public speeches, musical events, and various other publicity mediums. Thomas A. Edison himself has been busy for many months doing invaluable work for the Government, and those associated with him in his commercial enterprises are also doing their bit in their own way, as the rapidly mounting subscription list to the Fourth Loan demonstrates.

The charter of the Quincy Phonograph & Art Co., 411 Hampshire street, Quincy, Ill., has been surrendered and the corporation dissolved. Following the retirement of L. E. & J. E. Caldwell from the business, which was purchased by A. F. Odell last spring.

The Kehrberg-Schneider Co., LeMars, Ia., have purchased the talking machine business of Louis Bellaire in that city.

DEATH OF HAL DORIAN

Hal Dorian, a son of Marion Dorian, chief auditor of the Columbia Graphophone Co., New York, died last week at the home of his father in New York City, after a brief illness. Mr. Dorian, who was about thirty-three years of age at the time of his death, was formerly associated with the Columbia Co. and, until he entered the automobile business a few months ago, had been actively connected with the talking machine industry for a number of years. He was popular among his associates and co-workers, who are deeply grieved to learn of his sudden death. A widow survives Mr. Dorian.

LANGUAGE RECORDS IN SCHOOLS

Dealers are reporting good sales of Language Phone Method language records to educational institutions, especially to the schools and colleges that are preparing students for war service. The War Department's recent order, making the study of languages compulsory in the Students' Army Training Corps camps and schools, has given great stimulus to the sales of language records. The F. M. C. French Military Course is especially popular with these schools, for it covers all departments of the service.

Freemen buy bonds, slaves wear them.



YOUR GUESTS WILL BE DELIGHTED WITH THESE
NEW
Victor Dance Records

When Aunt Dinah's Daughter Hannah
Sings on the Piano "Swing"
Chasing the Chickens for Tea
Played by Six Brown Brothers

25676
Oriental Fox Trot
Dodola White Trash 135
Played by Joseph C. Scullin Orchestra

HAVE YOU SEEN OUR SET OF OCTOBER VICTOR DISPLAY CARDS?

Your Wholesaler has a complete Set.—Ask to See it! and compare with other Victor Service for Originality, Quality and Price.

IMPORTANT NOTICE!

Owing to enormous increase in cost of labor, material and stock and added detail required by the post office in arranging parcels for shipment, we are obliged to increase the price of ALL new subscriptions on and after November 1st, to \$3.00 per month, plus postage.

GET YOUR ORDER IN BEFORE THE NEW PRICE GOES INTO EFFECT.

Sold exclusively through Victor Wholesalers

ED. USOSKIN, Inc., 230 W. 17th St., NEW YORK CITY

Good things come in threes. There are three great operatic arias in the October Mid-Month. Sung by three world-famous artists for Columbia.



**Columbia Graphophone Co.
NEW YORK**

TRADE ACTIVE IN ATLANTA AND THROUGHOUT THE SOUTH

Dealers Look for Very Active Business Based Upon Their Ability to Get Goods—Leading Jobbers Are All Oversold Both in Machines and Records—News of Month

ATLANTA, GA., October 7.—The volume of business in talking machines in this city was somewhat less in September than in several months previous to that time, and this is not to be wondered at, when we take into consideration the fact that the draft set in good and strong about the middle of the month, and that every man practically, from eighteen to forty-six inclusive, was affected as a possible phonograph purchaser. However, toward the end of the month there was quite a quickening in the tone of business, and dealers are now enjoying a considerable revival over what was moving during the first three weeks of the month of September.

The Haverty Furniture Co., the largest retailers of the Columbia line in the Southern States, also Pathé dealers, say that, while their sales were not quite equal to the very large sales of August and July, they have no reason for complaint, this year's total sales to date being so far in excess of 1917 that the monthly average is very gratifying. They report an active sale of the better type Grafonolas, retailing at \$100 up, and, in fact, there are very few of the medium and low-priced instruments obtainable.

Manager Thornton, of this concern, states that

he is looking for a very satisfactory autumn and holiday business, and is making preparations to take care of it to the best of his ability. Buel Crawley, some time back connected with the Columbia line in another store in this city, has been engaged as assistant at Haverty's, and is well pleased with his new connection, and is making some fine sales.

The talking machine departments of the Haverty Co. in Savannah, Ga., Charleston and Columbia, S. C., Birmingham, Ala., Memphis, Tenn., and Dallas and Houston, Tex., all report fine business.

The Atlanta Talking Machine Co., dealers in the Columbia and Vocalion lines, are fortunate in having obtained the services of Miss Hood, formerly of the Phillips & Crew Piano Co., in their sales department. This young lady has already made a reputation for herself in the talking machine world, and her many customers and friends wish her the best success possible in her new connection.

This store report a very lively business in September. They were in an excellent strategic position, having a complete and trained sales force at a time when it is almost impossible to get and keep experienced employees.

I. M. & R. D. Bame, Victor and Sonora dealers, say that they are having a nice business on the better grade machines, retailing at \$100 up. They expect a continued activity indefinitely.

A report from eight dealers on popular records is that the six best sellers are "Just a Baby's Prayer at Twilight" in any form, "If He Could Fight Like He Can Love, Then It's Good Night Germany," "I'm Sorry I Made You Cry," "Oh, Frenchy," "K-K-K-Katy," "Belgian Rose." However, all records are in great demand with stocks considerably broken, and salable numbers short.

The demand for records is best illustrated by one Columbia dealer in Georgia who wired, "If you can't ship this year's records, ship last year's," thus indicating that anything in the nature of music is wanted.

The Cable Piano Co. are continuing an active business, with all Victrolas being sold as fast as they come in, and short stock with not much relief in sight. Their record sales are exceedingly large.

Phillips & Crew Piano Co., the oldest Victor dealers in Georgia, are in the fortunate position of having a fair stock in their wholesale Victrola department with which to "feed" their

retail store, although with their most efficient organization they would get their share of any business moving under any conditions.

Reports from the State at large and from the Southeastern territory are to the effect that all phonograph dealers are enjoying a satisfactory volume of business.

The Columbia, Victor and Edison jobbers or distributors report that they are oversold for weeks ahead and the demand for phonographs is far in excess of the supply.

The feature of the month was the advance in the price of the New Edison and the opening of the first exclusive Aeolian-Vocalion store in this territory. The Victory Phonograph Co. recently opened with the full Vocalion line and at once began booking a substantial business.

The Aeolian-Vocalion phonographs and records are now being handled in Washington, D. C., by Lamsburg & Bro., the big department store. G. C. Maust is in charge of the department.

Genuine Period Styles

Authentic adaptations of Adam, Louis XVI, Sheraton and Queen Anne periods, harmonizing perfectly with the styles whose names they bear, are a feature of the case work on the Marvelous

MAGNOLA "Built by Tone Specialists"



Watching the Music Come Out

Give us the Opportunity to tell you more about this and other sales-making features of MAGNOLA construction, by sending us your name and address.

We have a handsome catalog, illustrated in colors, that tells Magnola's story—and is yours for the asking.

MAGNOLA TALKING MACHINE COMPANY

OTTO SCHULZ, President

General Offices 711 MILWAUKEE AVENUE CHICAGO
Southern Wholesale Branch 1530 CANDLER BLDG. ATLANTA, GA.

MAKE YOUR SHOW WINDOWS PAY YOUR RENT

Record Display Stands, Hold any Size Record Golden Oak or Mahogany Finish—5 Sizes

No. 341. 1 Record \$1.00 ea.

No. 342. 2 Records \$1.25 ea.

No. 343. 3 Records \$1.50 ea.

No. 344. 4 Records \$1.75 ea.

No. 345. 5 Records \$2.00 ea.

THE OSCAR ONKEN CO. No. 6651 4th St., Cincinnati, O.



BROOKS AUTOMATIC REPEATING PHONOGRAPH



THE WONDER INSTRUMENT

Plays and repeats any kind or size record—any desired number of times—then stops automatically with the tone arm suspended off to the right in the air. Any child can operate it.

WONDERFUL TONE WONDERFUL FINISH
WONDERFUL IN ITS SIMPLICITY
The Machine Creates Interest and Discussion.
It is Self-Advertising
WONDERFUL SELLER

DEALERS—Send for Particulars, Prices, Terms.

BROOKS MFG. CO., Saginaw, Mich.

Interesting Review of the Financing of Dealers' Deferred Payment Sales :: :: :: :: By Harrison Durant

In a recent interview with Harrison Durant, financial supervisor of Thomas A. Edison, Inc., a representative of The Talking Machine World received many interesting statements that should prove of value to the trade.

"It has been six months since we inaugurated the arrangement with the Commercial Investment Trust for the financing of Edison dealers' deferred payment sales—better known as the C. I. T. Plan," said Mr. Durant. "The complete success of the plan deserves some comment. Probably every Edison dealer is more or less familiar with its history. How we spent a considerable sum to collect data which would throw light on the 'instalment problem,' and how we endeavored to make it possible for the Edison dealer to do an unlimited amount of instalment business. Our efforts were in the face of discouraging conditions, conditions which, as the war continued, certainly did not improve.

"Our initial efforts were directed along the line of trying to better the relations between individual dealers and their individual bankers: We made considerable progress and there are many dealers to-day and many banks which are enjoying more profitable relations as a result of those efforts. Certainly the proper place for the dealer to finance his business is with his local bank.

"However, it is not always possible to obtain adequate local accommodation. Comparatively few dealers are in the phonograph business exclusively. Their banks may readily enough take care of their ordinary business requirements, but when it comes to phonograph paper, well, they simply were not educated up to it. Although, as stated, we benefited many dealers and many banks by the results of our initial work, it was a slow process.

"Then came the thought that it would be best to prove our theories before placing them in practice; that is, literally, practice what we preached. The great benefit we, and indirectly our dealers, had received through our East Orange Experimental Store was sufficient excuse for this new experiment. We said: 'Let us arrange for an institution to accept Edison paper from any section of the country, including Canada, and to accept it in just the form presented—not on a specially prepared fool-proof contract. If our theory as to the manner in which phonograph instalment paper should be handled works out satisfactorily under those conditions then little argument is required to show the local banker just what Edison paper really is.'

The Experiment

"We had no way of knowing how much paper we would receive. We did not want to offer any plan which could not absorb any amount offered

The Commercial Investment Trust was the only concern which would meet our terms. By that we mean that the present charges for the C. I. T. Plan are those fixed by us, and accepted by the Commercial Investment Trust. They were terms we figured as being the highest a dealer could afford to pay—and we figured that the dealer could well afford to pay them if he was unable to obtain sufficient local accommodation. We repeat today what we stated six months ago—the C. I. T. Plan is the cheapest discounting proposition offered any phonograph dealer with which we are familiar.

"Not only that but its flexibility is an added attraction. We have approved accommodation to individual dealers from amounts ranging as low as \$75 to as high as \$25,000. We have successfully proved the safety of fixing the limit of accommodation on the value of the paper rather than on the financial worth of the dealer. The plan provides for a very simple means of keeping a check on a dealer's instalment collections—a check which enables us to recognize good paper from poor paper. There is no limit to the dealer who always meets his obligations and who always submits collateral which is up to our standard.

Making a Record

"Many thousand dollars' worth of Edison instalment paper has passed through our hands during the past few months. We are building up a record for the economical and safe handling of this class of collateral, which, when we are ready to disclose it, will open the eyes of the most conservative banks. Think of it, any kind of paper drawn on all manner of forms from all sections of the country, all being absorbed by one institution! If it is good collateral in New York City, it is 100 per cent. better in the dealer's own locality.

"So, we feel our experiment has been most successful. Our dealers can truthfully say, 'Why, Mr. Banker, surely if my paper is acceptable in New York, it should be acceptable with you.' We are grateful to the Commercial Investment Trust for the very efficient manner in which they are developing the plan, and, on our dealers' account, we are glad such a plan is possible at a time when financial accommodation is a most uncertain commodity.

"Any Edison dealer of good standing can utilize this plan with his jobber's assistance. Whether the dealer is an old friend or a new one, whether he is a big dealer or a little dealer, or whether he does business on the Pacific Coast or the Atlantic—it is all one and the same to the C. I. T. For the dealer who cannot obtain sufficient local accommodation we commend the plan. If, on the other hand, we can be of assistance in establishing better relations between a

dealer and his banker in connection with Edison instalment paper, we are only too glad to give the banker the benefit of our experience. Whether it is the C. I. T. Plan or any other plan, or whether it is a question of assisting the dealer in making similar arrangements with his own bank, our financial supervisor is here at the factory and ready at all times to assist in every way possible."

SOME SEASONABLE NOVELTIES

National Toy Co. Introducing Several Which Should Appeal to Dealers During Holidays

The National Toy Co., 273 Congress street, Boston, Mass., are receiving large demands for their various talking machine specialties. The Boxers, Ragtime Rastus and Uncle Sam and Kaiser Bill have become popular throughout the



Ragtime Rastus Window Display

country. The approaching Christmas season has given renewed interest to this line, as many dealers feature this toy in their windows upon the revolving turn table of a machine. Its attraction value is strong, and has been the subject of comment at various times in the daily press.

Although the window shown herewith appeared in Boston, this has been duplicated on Fifth avenue, New York, and in practically every town and city in the country. In view of current happenings, it is expected that the toy in which Uncle Sam administers punishment to Kaiser Bill will prove very popular.



Immediate Deliveries of the STERLING

"The Phonograph of Sterling Tone and Quality"

THE Sterling phonograph is no experiment, but an established line, having been on the market since 1914. Handle a line that is known—a product of experienced phonograph manufacturers.

Every model is equipped with a universal tone-arm playing all records. The motor is the best that can be secured and the cabinet work is exceptionally fine.

Liberal trade discounts.

Compacto Phonograph Co., 31 East 12th Street, New York City

Eight Models

Guaranteed in Every Detail

Immediate Deliveries of Any Quantity

IMPORTANT PATENT GRANTED

The Windsor Furniture Co. Secure Protection on a Most Ingenious Method of Disposing of the Records in Their Artistic Cabinets

CHICAGO, ILL., October 10.—The Windsor Furniture Co. announce that on September 24, 1918, they were granted U. S. patent protection for a new and valuable extension of the characteristic Windsor console cabinet, which they have developed so successfully. As is well known, the Windsor phonograph cabinets are of the console type and the new patent is granted on a most ingenious method for disposing of the records in vertical filing order in a special space adjoining and on a level with the part of the console which contains the machine itself. In this manner the console dimensions are faithfully preserved, as well as the characteristic lines of the design. The patent is granted on the mechanical claims involved, not merely on the design, and is the first mechanical patent, the company believes, yet granted on phonograph cabinets. Windsor machines are brought out in a variety of beautiful period styles, and their new catalog shows that they are also bringing out several upright cabinet styles. The Windsor is highly superior in all respects of design and workmanship and has already developed a large circle of enthusiastic patronage.

Hinners Organ Co. are the owners of the Pekin Music House opened recently in Pekin, Ill.



Made UP to a Standard

Not DOWN to a price



Prices Range from \$80 to \$165

Four Styles

Ready for Immediate Delivery

Territory open for Agents.

Send for details and dealers' discounts. Helpful booklets furnished to Culptone dealers free.

Culptone Phonograph Co.

240 Broadway

New York

Record Delivery Envelopes
Safe - Swift - Secure



The heavy paper means protection; the button and cord mean speed—you can wait on more customers. Bring out YOUR OWN NAME. Every time an envelope leaves your store, let the advertisement on it take your name to the homes and bring new trade. The advertising more than pays for the envelope. Write for samples and prices. Lewis C. Frank, 694 Book Bldg., Detroit

HAS BUSH & LANE AGENCY

Fred K. Kurtz to Represent This Well-Known Phonograph Line in Chicago

Fred K. Kurtz, who has spent a lifetime in the manufacturing and selling ends of the music industries, has been made Chicago representative for the Bush & Lane phonograph, made by the Bush & Lane Piano Co., Holland, Mich. He has secured downtown warerooms and occupies office space with Wyman & Babb on the sixth floor of the Republic Building for the present.

VICTOR CO. REPLIES TO RESOLUTION

The Talking Machine Men, Inc., have received from the Victor Talking Machine Co. a formal reply to the resolution adopted at the recent special meeting of that organization asking the Victor Co. to take action to have jobbers discontinue the retailing of Victor goods. The reply will be made public at the regular meeting of the Talking Machine Men, Inc., to be held on Wednesday of this week.

SWINDLERS ARE SENTENCED

Reference was made in The World for August to the arrest of a man named John W. Rogers and an accomplice named Silvia, who were charged with swindling numerous talking machine dealers in this city, the arrest being brought about through the united efforts of C. H. Ditson & Co., John Wanamaker and Bloomingdale Bros., who succeeded in developing a plan that enabled them to secure the arrest of the swindlers. This week these two parties were found guilty. Rogers was sentenced to serve thirteen months in Elmira Reformatory, and Silvia to serve not less than a year and four months, and not more than two years and eight months in jail.

INTRODUCE CULPTONE PHONOGRAPH

The Culp Phonograph Co., 240 Broadway, New York City, through their president, A. Culp, made the initial announcement of their new line of talking machines this month, known as the "Culptone." The four models comprising the line have cabinet design of exceptional merit, and are equipped with up-to-the-minute accessories and have a price range of wide latitude. An ingenious slogan has been adopted by the company, "Made UP to standard and not DOWN to price."

SECURE PURITAN AGENCY

The Kranich & Bach store in Chicago has taken on the entire line of Puritan phonographs manufactured by the United Phonographs Corp., of Sheboygan, Wis.

RECORDS FOR THE SOLDIERS

The Sharp Music Co., Denver, Colo., have been collecting records and talking machines for the soldiers and recently made a large shipment to the boys "over there." The campaign was a most successful one in every respect and won the approval of the public.

A new talking machine department has been opened on the main floor of "The Fair," the well-known department store on State street, Chicago. The Victor and Columbia lines are handled.

"NICHOLSON"
New Catalog Showing New Styles
RECORD CABINETS
strictly high-grade construction at prices
BELOW COMPETITION
Write for a copy of the catalog and our special free advertising help for dealers.
K. NICHOLSON FURNITURE CO., Chase City, Virginia
Sectional Bookcases and Record Cabinets

The Most Wonderful Talking Machine at the Price

The Charmaphone

An Instrument of Supreme Value, Tone and Quality



No. 100

Wholesale Price \$42.50 and War Tax
Terms 5%—10 days, Net 60 days.

A high class Mahogany finished Cabinet 44" high and 18" wide and 21" deep.

It is equipped with a Heineman No. 3 Motor which will play five records without rewinding and is guaranteed by the manufacturer.

The large Tone Arm and Sound Box used is the same as used by other manufacturers of machines selling as high as \$200.00.

The record cabinet has three shelves as illustrated. It is equipped with a modifier and ballbearing casters.

All parts heavily nickel plated. This machine must be seen to be appreciated.

Let us send you a Sample Machine.

We carry a line of Phonographs from \$9.50 up.

Write for Catalogue and Price List.

R. L. Kenyon Mfg. Co.
Mexico, N. Y.

WORLD'S CLASSIFIED ADVERTISING

Any member of the trade may forward to this office a "Situation" advertisement intended for this Department to occupy a space of four lines, agate measure, and it will be inserted free. Replies will also be forwarded without cost. Additional space will be at the rate of 25c. per line. If bold faced type is desired the cost of same will be 25c. per line.

SALES EXECUTIVE of high caliber with a past record of things accomplished and an intimate knowledge of manufacturing and who has recently placed on the market with signal success one of the representative talking machine lines in the trade will consider new connection. My highly specialized services will be of particular value to some big live concern ambitious to become or continue real factors in the talking machine field. Address "Box 554," care The Talking Machine World, 373 Fourth Ave., New York.

RELIABLE phonograph factory executive, experienced in motors and cabinets, and thoroughly familiar with all repair work wishes to better his position. Excellent references. Address "Box 555," care The Talking Machine World, 373 Fourth Ave., New York.

WANTED—New and second-hand Victor and Columbia talking machines and records. Spot cash paid for them. Deninger Cycle Co., Rochester, N. Y.

WANTED—An experienced man to assemble and pack phonographs. Address "Box 556," care The Talking Machine World, 373 Fourth Ave., New York.

POSITION WANTED—Assistant manager of branch of America's largest phonograph supply factory, is open for executive position. Address "Box 548," care The Talking Machine World, 373 Fourth Ave., New York.

PHONOGRAPH recorder required, thoroughly experienced and able to install and operate. Replies confidential. Address "Box 558," care The Talking Machine World, 373 Fourth Ave., New York.

POSITION WANTED—City salesman or department manager—by man of twelve years' experience. Best references. State particulars. Address "Box 549," care The Talking Machine World, 373 Fourth Ave., New York.

We have an opening for one or two good salesmen. Salesmen that are willing to work, hustle and bring results. Prefer man who will work on commission. Must come well recommended, send information and references in first letter. Address "Box 550," care The Talking Machine World, 373 Fourth Ave., New York.

FOR SALE—Thriving business, Columbia Agency, with full line of records, also a few pianos. Store is equipped with demonstration booths. Ideal location. Will sell to purchaser at inventory. Address "Box 551," care The Talking Machine World, 373 Fourth Ave., New York.

REPRESENTATIVE exceptionally well known on Pacific Coast, already carrying several representative lines, offers representation to one or two more non-conflicting lines in that territory. Will be glad to consider your proposition. Address "Box 553," care The Talking Machine World, 373 Fourth Ave., New York.

MANY SONORA VISITORS

The executive offices of the Sonora Phonograph Sales Co., Inc., were visited this week by quite a number of the company's jobbers who are attending the annual convention of the National Wholesale Druggists' Association, and who took advantage of this opportunity to visit Sonora headquarters and make a unanimous plea for immediate carload shipments of Sonora phonographs.

Among these callers were H. E. Hillman, of Wheeling, W. Va.; Fred E. Yahr, treasurer of the Yahr & Lange Drug Co., Milwaukee, Wis.;

POSITION WANTED—Young lady with several years' experience in managing Victor and Columbia phonograph and record departments, also music roll departments, and handling large sales force, is desirous of securing permanent position with large music house. Can furnish references. Address "Box 557," care The Talking Machine World, 373 Fourth Ave., New York City.

SITUATION DESIRED—Production manager and superintendent seeks position. Seventeen years' experience. Can reduce costs and increase production. Highest references. Address "S. P. 25," care The Talking Machine World, 209 South State St., Chicago, Ill.

PRODUCTION MANAGER—FACTORY SUPERINTENDENT—Expert production man seeks position. Location no special object. First-rate handler of men. Seventeen years' practical experience in talking machine manufacture. Is competent to plan, and reduce costs and increase production in all branches. Has special skill in the matters pertaining to the woodwork and cabinet-making and assembling and finishing. Can give the highest of references and demonstrate his ability. Will work for \$200 per month, and is worth it. Address "S. P. 26," Talking Machine World, 209 South State St., Chicago, Ill.

RETAIL MANAGER OPEN—Young man, married, long experience as retail manager, open for exclusive store or department executive, talking machines or pianos or both. Middle West preferred. Address "08," Talking Machine World, 209 South State St., Chicago, Ill.

SITUATION WANTED—By expert with eleven years' experience in all branches phonograph line, making, assembling and repairing. Can take complete charge of mechanical end. Had charge of some of large concerns in the manufacturing and assembling from motor to complete machine. Am a good systematizer and organizer. Address "A. U. 1," care The Talking Machine World, 209 South State St., Chicago, Ill.

SITUATION WANTED—Who can use a high-class manager, either wholesale or retail, capable of taking exclusive charge and producing results? Have had over ten years' experience, willing to locate anywhere. Address "Box 540," care The Talking Machine World, 373 Fourth Ave., New York.

SITUATION WANTED—Salesman (35) acquainted with every angle of the business. Phonographs, records and sundries. Vigorous result getter on road. Drawing account against commission. Address "Phonographs," 22 East 125th St., New York.

POSITION WANTED—Talking machine salesman, five years' experience. Inside position large city preferred. Familiar with all well known machines. References. Address "A. P. 2," Talking Machine World, 209 So. State St., Chicago, Ill.

WANTED—Thoroughly experienced, aggressive Edison, Victor and Columbia manager is open to manage department. Any location. Success guaranteed. Address "J. L. 8," care The Talking Machine World, 209 South State St., Chicago, Ill.

SITUATION WANTED—Trade builder open for position November 1. My record of sales will be of interest to manufacturers who wish to further their output. Address "Box 560," care The Talking Machine World, 373 Fourth Ave., New York.

POSITION WANTED—By wholesale phonograph and piano salesman. Open for position to travel east of Chicago. Held last position 2½ years. Phonograph position preferred. Best of references. Address "Box 536," care The Talking Machine World, 373 Fourth Ave., New York.

Sewall D. Andrews, of the Minneapolis Drug Co., Minneapolis, Minn.; G. B. Moxley, of the Kiefer-Stewart Co., Indianapolis, Ind., and Chas. Gibson and Nelson P. Snow, of the Gibson-Snow Co., at Syracuse, N. Y. All of these callers spoke most encouragingly of the business situation in their respective territories, stating that their sales of Sonora machines were limited only by the available supply of merchandise. They are all looking forward to a banner fall and holiday business, and, in a conference with the Sonora executives, emphasized the fact that they needed large shipments of instruments in order to cope with this demand.

STEEL NEEDLES

AND PHONOGRAPH PARTS

Steel needles, full tone, in envelopes, per 1,000 needles...	0.75
Sapphire needles for Edison disc, each.....	0.30
Sapphire needles for Pathé disc, each.....	0.30
Genuine Edison diamond for disc, each.....	2.25
Main springs for Edison disc, 1½", each.....	1.75
Main springs for Columbia disc, 1", each.....	0.65
Main springs, ¾" ohlong hole, each.....	0.35
Main springs for Columbia disc, ¾" round hole, each.....	0.30
Governor springs for Columbia motor, each 2c.; per 100.....	1.50
Governor springs for Victor motor, each 2c.; per 100.....	1.50
Governor screws for Columbia motor, each 1c.; per 100.....	0.75
Governor shafts for Blich or Wonder motor, each.....	0.15
Governor shafts for Heineman No. 0 or 11, each.....	0.20
Governor gear wheels, for Triton motor, each.....	0.10
Mica diaphragms, 1st for Victor soundbox, each.....	0.15
Mica diaphragms, 1st for Columbia soundbox, each.....	0.25
Mica diaphragms, 1st for all Standard soundboxes, each.....	0.22
Turn-table, felt green, 10", each.....	0.20
Turn-table, felt green, 12", each.....	0.25
Motors, double springs cpt. with 12" T. T., each.....	5.25
Motors, single spring cpt. with 10" T. T., each.....	2.25
Tonearms, universal, with mica soundbox No. K-1, each.....	2.00
Tonearms, universal, No. H2, Sonora style, each.....	3.00
Soundbox, fit Victor tonearm, No. H-1, each.....	1.75
Soundbox, fit Standard tonearm, No. K-5, each.....	0.75
Barrel, assembled, for Blich or Triton motors, each.....	0.60
Barrel, bottom gears, Blich or Triton motors, each.....	0.25
Key's Slated, Blich or Triton, each.....	0.25
Key's Thread, for Flemish, each.....	0.25
Needle cups, fit on Columbia, per 100.....	2.50
Needle cups, with covers, for used needles, per 100.....	3.75

All orders must be accompanied with remittance.
Prices subject to change without further notice.

FAVORITE PHONOGRAPH ACCESSORY CO.

1491 DeKalb Avenue

Brooklyn, N. Y.

FOR SALE

Phonograph records, lateral cut, 10 and 12 inch standard make, a fine assortment of vocal and instrumental selections. Also steel needles, finest quality, in bulk and packages.

I. DECKINGER

3064 Albany-Crescent Ave.

New York

A REAL SALESMANAGER wanted, experienced in the phonograph business. Must be a live wire and able to handle a staff of salesmen successfully. Apply to the Chopin Phonograph, Ltd., Keewadyn Building, Winnipeg, Canada.

FOR SALE

A balance of a large stock: 5,000 Victor, Columbia and Emerson records; 500 1-inch main springs at 28c.; 500 micas for Columbia sound boxes at 20c.; 10 and 12 inch turn tables, 10c. and 20c. Complete large covered machines 18x20 at \$6.50, 14 inches high.

N. WALCER

144 Ludlow St.

New York

WE are in the market to buy a laboratory plating and pressing outfit. Who has one? What is your price?

We also wish to make arrangements for commercial pressing of records. Give us deliveries, price, capacity. 10-inch, single and double face. "Box 559," care The Talking Machine World, 373 Fourth Ave., New York.

MUSIC HELPS SPEED UP WORKERS

Phonographs Installed in Cincinnati Establishment as Aid to Production

CINCINNATI, O., October 7.—The music-with-meals idea is now being supplanted by the music-with-work theory, which a local dry cleaning establishment is putting into practical effect. This enterprising firm has installed throughout its factory enough phonographs to provide lively entertainment the whole day long. It is a pleasant way of saying "speed up" and has the desired effect on the workers who have taken to the new idea with great zest. The idea has been tried out with success elsewhere.



The Most Wonderful Talking Machine

of the present age at the price, considering cabinet, tone and quality.

The name "Wegman" has been before the music-loving public since 1882.

Solid mahogany, 5 record motor, 12" turntable, tone modifier, graduated regulator, plays all records. All parts heavily nickel plated.

Write for dealers' proposition.

We are also in a position to furnish cabinets only.

Wegman Talking Machine Co.
Office, 47 Clinton Ave., So. Rochester, N. Y.

\$90

47" high
22½" deep
21" wide

NEEDLES

WE MANUFACTURE

Diamond needles for Edison

Sapphire needles for Edison

Sapphire needles for Pathe

in stock ready for delivery

MERMOD & CO., 505 5th Ave., N. Y.

THE ORIGIN AND USE OF GRAPHITE

Some Facts Concerning This Important Mineral of Which Little Is Generally Known

Although graphite is deemed practically essential in the lubrication of every talking machine motor, particularly in the lubrication of the springs thereof, there is little generally known in the trade, however, of the origin of that mineral, where it is found and the manner in which it is prepared for the mines. The following information regarding graphite, published by the U. S. Graphite Co., should therefore prove of interest:

Although graphite is used by all of us in one form or another every day of our lives, there is a surprisingly small number of people that have even a passing knowledge of its origin, its characteristics, or in fact the purposes for which it is utilized.

Graphite comes from Ceylon, Korea, Madagascar, Mexico, Europe and also occurs frequently throughout the United States and Canada.

There are two formations of graphite—crystalline or "flake," and non-structural or amorphous.

"Flake" graphite is imported into the United States principally from Ceylon and Madagascar, and this together with the high quality and close grading demanded by the nature of the finished articles into which it is developed give it a high market value. Probably the best known product of flake graphite is the crucible used so extensively by chemists and metallurgists, and in the process of manufacture in brass foundries and steel mills. A crucible must be able to withstand tremendous heat with minimum deterioration either from the heat itself or from the physical strain imposed by handling and by the molten substance being heated in it. In addition it must be capable of conducting heat quickly and efficiently.

Flake graphite is also used extensively in the manufacture of electrodes, electrical contacts, dynamo brushes, etc., and must necessarily possess high and uniform electrical carrying capacity.

The amorphous variety of graphite, which is produced throughout the United States and largely in the State of Colorado, where large deposits have recently been discovered and developed, is also imported from Korea, Canada and Mexico, and presents many physical characteristics very different from the crystalline product. It is marketed in the form of a grayish black powder, and adapts itself to service more utilitarian than scientific, and due to its larger and more general production, its monetary value is greatly below that of the flake variety. Its industrial uses are many, including for instance, foundry facing, that is, a powder applied to the face of sand molds to prevent the taking up of silica by molten metal; axle grease, a cheap but effective commodity used everywhere; paint, to protect metal surfaces from the corrosive action of climate, smoke, steam or chemical fumes; polish for locomotive front ends; greases in many varieties for use on mine cars, machines, cables, gears, chains, etc.

These of course are only a few of the uses to which graphite of both varieties is adapted, but they serve to give an idea of the range of service, the general usefulness, and the comparative values of the two formations.

The Kaiser has not invested in War Savings Stamps. Are you like the Kaiser?

SHELTON ELECTRIC PHONOGRAPH MOTOR

We have increased our factory facilities to handle the demand for the Shelton Electric Motor, and are now ready to make prompt deliveries.

Write for our Special Agency Proposition

SHELTON ELECTRIC CO.
30 East 42nd Street, NEW YORK

The CHENEY PHONOGRAPH

"Plays all records better"

Large surplus stock now in New York City for immediate deliveries in New York and Northern New Jersey.

Write for Catalog and attractive Agency proposition.

BURTON COLLVER

Rep. New York and Northern New Jersey

4 West 40th Street
NEW YORK CITY

Telephone
Murray Hill 6576

STIMULATING THE SALES FORCE

How It May Be Made to Push Your Product Intelligently—Some Pertinent Remarks That Are of General Interest to Dealers Everywhere

How to induce a sales force to handle your product, to push it intelligently—that is the problem that confronts almost every manufacturer, said the proprietor of a large establishment recently. In this connection we reproduce some quotations from a booklet on the subject which is illuminating because of its general application:

"Selling Is Knowing.—Selling the goods has certain requirements. One man we've known who tried to dodge the duty by daily talking the weather to a frazzle—letting his goods talk themselves. Another man finally decided that salesmanship consisted in a fine lot of phrases like 'It's the best,' and 'There's nothing finer.'

"Yet, as clerks they were then, so clerks they have remained. For one thing they never learned—that for a man to sell goods he must know goods.

"So study the merchandise you handle as you would your friends. KNOW their every quality, characteristic and difference. Be able to say 'This is so, because'—and prove it. For the very alphabet of selling is facts. Get these facts. Make them a part of you.

"The Sales Key to Salaries.—Many things enter into your advancement—and its visible token, the dollars. If you are prompt at work the boss smiles—loyal to the house, he appreciates—and always cheery, he gives you his confidence.

"But when it's raise-time, what does he go on? 'Figures don't lie,' some one has told him. Your sales book is going to be his evidence to convict or promote you. Character, ability and

ambition can all play their part, but it's the sales that are going to make you a higher-paid salesman; sales that are going to let you press onward. Watch your sales. Don't miss a chance to build them. Sales is the watchword of salesmanship.

"This booklet gives the few truths which are essential to every salesman of any product. If you would boost yourself upward, read it. For the dollars that lie within it, make this information yours."

JOSEPH I. CARROLL'S NEW POST

Arthur A. Cushman, director of sales, Emerson Phonograph Co., announces the appointment of Jos. I. Carroll as manager of sales for this company.

IN CHARGE IN NEW ENGLAND

W. H. Shire has been appointed New England manager of the Emerson Co. with headquarters in Boston.

OPENS NEW YORK OFFICE

Burton Collver, who now represents the wholesale interests of the Cheney Talking Machine Co., with headquarters in New York, is carrying a large surplus stock of Cheney phonographs for immediate delivery, including the Console models designed and executed by Berkey & Gay, the renowned makers of fine art furniture.

MAESTROLA MAHOGANY CABINET MACHINES, SIZE 15 x 15 x 7½

Motor worm gear plays 2½ to 3 ten inch records, one winding. Prices \$4.50 in 100 lots, in dozen lots \$5.00 each, sample machine \$5.50. Cash with order.

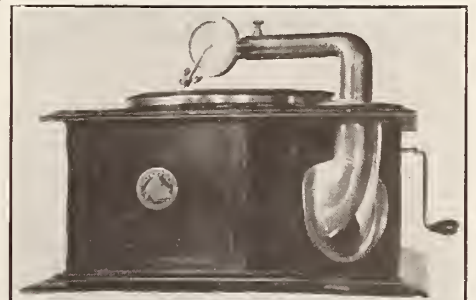

Steel needles and phonograph parts selling at the old prices during October regardless of the scarcity of these supplies. Now is the time to place your order. Be wise and save money.

FULTON TALKING MACHINE COMPANY
640 Broadway New York City, N. Y.

REPAIRS

All Makes of Talking Machines
Repaired Promptly and Efficiently

TALKING MACHINE REPAIR
AND SALES CORPORATION

ANDREW H. DODIN, President
176 Sixth Avenue New York

TELEPHONE, CHELSEA 8437

FROM OUR EUROPEAN HEADQUARTERS

2 GRESHAM BUILDING, BASINGHALL STREET E. C., LONDON, W. LIONEL STURDY, MANAGER.

Growing Feeling of Optimism Prevails Throughout the Gramophone Industry in Great Britain, Due Primarily to the Glorious Successes of the Allies on the European Battle Fields and the Confidence Aroused That Daylight Is Now Ahead and That the End of the War Is at Last in Sight—Increased Demand for Records a Notable Feature of the Month—Larger Machine Output Now Necessary to Meet Increasing Demand—News of Month

LONDON, E. C., ENGLAND, October 3.—As in the case of most industries, other than those catering to actual every-day necessities, the gramophone trade, indeed, the whole music and allied commercial undertakings, are undoubtedly very sensitive to political and economic influence, the more so these days of strife. It is therefore with no great surprise that one learns of the existence of a strong tendency towards increased sales, partly, it is true, to the bad weather conditions which have prevailed of late, but in the main attributable to the glorious successes of the Allies on the European battlefields. The recent splendid news of the first independent success of the American army has aroused a spirit of high confidence. For the first time in a period of over four years of bloodshed the people are able to see daylight ahead. The measure of our enemies has been taken, and we feel this side, thanks to the mighty assistance of the United States, that while there is yet a stern period to face before the Prussian defense is reduced, the end is at last in sight. Determination to pursue and attain an unqualified successful conclusion of this fight for the maintenance of civilization is stronger than ever. The people are animated by the will to conquer,

and in that are sustained with the significance of the magnificent part now taken by our cousins from across the wide Atlantic.

Can one then wonder that there is a spirit of relief and hope abroad? Even the predisposed pessimists are smiling. There prevails a mood of general cheerfulness. Our reservoir of gladness and hope is again unlocked to some purpose. Money is freer. There is a call for music. The gramophone dealer has "felt" it. He is selling more records, and it will be up to the manufacturers to increase their output considerably. The demand, too, from the front is greater than ever. Our soldiers want music wherever they go. And they shall have it, even though the home trade suffers.

Thus do we find that business conditions are generally excellent. Record sales are great. Efforts must be made by manufacturers to increase output, and night shifts, when labor can be found, will soon be necessary. The class of music provided is mainly of the ephemeral order, but it is, on the average, good. Anyway, it is what is wanted, and the main thing at the moment is certainly to completely satisfy the demand. The experience of dealers is that officers and men on leave prefer music of the lighter variety, and at the front the call is always for selections of the very latest of London's repertoire in presentation at the theatres, music halls, etc. Hence, in the main, record lists are compiled along these lines.

If there were available a larger output of machines, all would be well. The shortage, however, is likely to prevail during the war period, as there seems little or no possibility of any British output of motors in bulk. There is, of course, official restriction on the utilization of

machine tool capacity for this class of work, and inclination is generally averse to the employment of skilled labor thereon. It is true attempts have been made by scratch labor on comparatively worn out tools in the production of gramophone mechanism. One could not expect the result to be other than failure in view of the very great accuracy required for this output. A successful motor can only be produced by highly skilled mechanics on first-class machines. The many operations necessitated call for precision workmanship on precision tools; single-purpose machines in a good many of the operations entailed being absolutely essential. These are not available until the need for war output is canceled by the attainment of peace. Until that glorious event is possible the trade must be content to rely upon Swiss imports of motor mechanism and much other of the metal parts and accessories for talking machines. When "the day" arrives all our energies will be concentrated towards the production of all we need in the way of gramophones so as to exclude, if nothing else can, further reliance upon enemy sources. But it is to be devoutly hoped that our manufacturers will receive official protection in the re-establishment of their pre-war industries by the only certain method of strong legislation designed to prevent the dumping of enemy products on this and our colonial markets. To that end all good citizens will accord, we think, every support to the Government of the day.

"His Master's Voice" Records' Increased Price

With an almost certain imposition in view of a luxury tax upon records, there is a strong tendency to anticipate events by the prior introduction of new prices, doubtless, with the



"His Master's Voice"

Copyright

This intensely human picture stands for all that is best in music

—it is the "His Master's Voice" trade-mark, and it brings to you, no matter where you are, the very best music of every kind, sung and played by the world's greatest artists—the greatest singers, pianists, violinists, orchestras and bands—all enshrined in the unequalled "His Master's Voice" records

'His Master's Voice'

—the trade-mark that is recognized throughout the world as the

HALL-MARK OF QUALITY

Branches

DENMARK: Skandinavisk Grammophon-Akti-
eselskab, Frlhavnen, Copenhagen.

FRANCE: Cie. Française du Gramophone, 115
Boulevard Richard Lenolr, Place de la République,
Paris.

SPAIN: Compañía del Gramófono, 56-58 Balmes,
Barcelona.

SWEDEN: Skandinaviska Grammophon-Aktie-
bolaget, Drottning Gatan No. 47, Stockholm.

RUSSIA: The Gramophone Co., Ltd., 45, Nevsky
Prospect, Petrograd (Petersburg); No. 1
Solyanka, Solyanov Dvor, Moscow; 9, Golovinsky
Prospect, Tiflis; Nowy-Swiat 30, Warsaw; 33,
Alexandrowskaya Ulitsa, Riga; 11 Michalovskaya
Ulitsa, Baku.

INDIA: The Gramophone Co., Ltd., 139, Bal-
lghatta Road, Calcutta; 7, Bell Lane, Fort,
Bombay.

Great Britain:

The Gramophone Company, Ltd.

HAYES - MIDDLESEX - ENGLAND

Agencies

AUSTRALIA: S. Hoffnung & Co., Ltd., Sole
Concessionaries of The Gramophone Company,
Limited, 163, Pitt Street, Sydney.

NEW ZEALAND: Gramophonum, Ltd., 118-120
Victoria Street, Wellington.

SOUTH AFRICA: Darter & Sons, Post Box 174,
Capetown; Mackay Bros., Post Box 251, Johannes-
burg; Mackay Bros. & McMahon, Post Box 419,
Durban; Ivan H. Haarburger, Post Box 105,
Bloemfontein; Franz Moeller, Post Box 108, East
London; B. J. Ewlns & Co., Post Box 86, Queens-
town; Handel House, Kimberley; Laurence &
Cope, Post Box 132, Buluwayo; The Argus Co.,
Salisbury.

EAST AFRICA: Bayley & Co., Lourenço
Marques.

HOLLAND: American Import Co., 22a, Amsterd
Veerkade, The Hague.

ITALY: A. Bossi & Co., Via Orefici 2, Milan.

**EGYPT (Also for the Soudan, Greece and the
Ottoman Empire):** K. Fr. Vogel, Post Box 414,
Alexandria.

FROM OUR LONDON HEADQUARTERS—(Continued from page 108)

J. Stead & Co., Ltd.
Manor Needle Works
SHEFFIELD, ENGLAND
 MANUFACTURERS OF
Talking Machine
Main Springs
Best Prices—Best Quality
Inquiries Solicited

object of relieving the public of direct payment and also to avoid, if possible, the expense involved by the suggested adhesive duty stamp as a means of collection. In more ways than one it would obviously be advantageous in elimination of confusion, trouble and expense for the official accountants to check sales at the factory end, allowing rebate for returned records, and collect the duty on the spot, say, every month. Several members of the select committee were in favor of this course. It will certainly receive sympathetic consideration when the official terms of the proposed bill are debated in Parliament.

It is not suggested for one moment that the foregoing is the main guiding principle for the introduction of new record prices at this stage. It is certainly not unassociated with the coming luxury duty on records, but, apart therefrom, there is every justification for raising the retail prices of discs of all denominations. Wherever one looks to-day, production costs and values generally are unfortunately meteoric. Record ingredients, in fact, all materials are more costly each week, prices constantly fluctuate, there is no stability, and each monthly balance sheet shows a proportionate reduction of profits in comparison with its immediately preceding period. The necessary introduction of women labor has proved over-expensive, and encouragement in the shape of increased rates of payment is all too frequently essential in order to retain their services, and thus ensure a sufficient output of satisfactorily finished records.

That, in brief, is the position. It outlines a few only of the many difficulties of manufacturers. But they have all to be faced, and overcome, in which regard the principle of good finance plays the most important role. Without a reasonable margin of profit, these production troubles of war time could not be successfully met. It is a fact that manufacturers' profit has become beautifully less. And to-day there is little or no margin with which to play. It follows, therefore, that the retail price must be increased as an actual necessity in the interests of continued output. Such action was foreshadowed by your correspondent quite some time ago. And it is now *au fait accompli*.

In the march of progressive action, the Gramophone Co., Ltd, stands boldly forth as

the first to move. Announcement has been made to the trade of an all-round increase of 6s each in the price of their single and double plum, black and violet label records. All other of their records (the higher-priced variety above 5/) remain at the old figure. A form is provided for dealers to make a return of their stocks in order that in the event of a return to the old prices when normal conditions once again prevail, the company may be in a position to decide upon any reasonable adjustment in favor of those dealers who now supply the required information, which is a judiciously fair proposition in the interests of "His Master's Voice" dealers. New needle prices have also been announced. This advice to the trade is accompanied by a warning against any infringement of prices, and reads as follows: "Any sale of the above records and needles on or after the 16th of September, 1918, at less than the new retail prices will be construed as a breach of the price maintenance agreement."

As to other makes of records, especially the 2s. standard variety, there is good ground for the belief that revision of prices must be made within the near future. If, in this case, the luxury tax is not anticipated by an early increase, it will be the more difficult for manufacturers to secure their due after this measure becomes law. The time for action is now, and I confidently believe that by the time these lines reach the London reader, a declaration of policy will have been made by all the 2s. record firms. I even go so far as to anticipate the increase, at sixpence per record. It is absolutely necessary for the manufacturer, the factor, and the dealer. Were it otherwise, I should not advocate any such policy in war time; the only justification for this step is the necessity brought about by increased costs of production, and at that I leave it.

Meeting of New Association

At a recent committee meeting of the Association of Gramophone & Musical Instrument Manufacturers, those present were: M. E. Ricketts, president, in the chair; Frank Samuel, vice-president; Louis Sterling, D. J. Blaikley, H. Hinks Martin, M. F. Cooksey, A. G. Houghton, Geo. Murdoch, H. J. Cullum, E. C. Paskell, C. E. Timms, secretary.

Applications for membership from the following houses were unanimously approved and accepted: Dalton & Sons, Leicester and Derby; Stockall, Marples & Co., Ltd., Clerkenwell road; H. E. Hornby, Hills place, Oxford street; R. J. Ward & Sons, Liverpool; Wm. Moore Holloway.

The need for this association and its usefulness to members was shown in the extensive correspondence reported by the secretary as received and replied to, dealing with a variety of questions of supplies, import and export formalities, etc., matters of common knowledge to the larger houses, but presenting difficulties to the smaller firms, who are in the majority.

Soundboxes

If you are after a genuine offer of soundboxes, you'll do well to communicate with us immediately. We have tens of thousands of perfect soundboxes, fitted with the best quality mica. Confidently recommended for cheaper machines, absolutely reliable and give excellent reproduction. Price to clear \$50 per gross, F. O. B. London.

Orders for less than gross lots not accepted

Wire "Knotaslepe, London".

W. H. Reynolds (1915) Ltd.

45, City Road, London, E. C.

Write for new illustrated
Complete Catalogue

This pooling of information of general and special interest provides some of the best work for such an association and is calculated to help the trade considerably.

Supplies of main springs and needles in the gramophone section, and mouth organs in the musical wholesale section are some of the smaller troubles of the present time which are receiving the attention of the association on behalf of members.

Of the larger and most important issues, the recommendations of the Ministry of Reconstruction are having close consideration with a view to their adaptation to the needs of the industry, and an interview on the subject will shortly take place at the Ministry.

The luxury tax report was also closely criticized and discussed. The absurdity of the schedule as it affects the trades within this association is apparent, the special classification of violins at £7 and the relegation of all other musical instruments of an equally important, artistic and democratic character, such as violoncello, cornet, etc., to the £1 limit, being, to say the least of it, preposterous.

On the motion of Frank Samuel, seconded by Louis Sterling, it was unanimously resolved that the association shall deal with the whole question of the luxury tax as it affects the interests of its members and of the trades represented by the association. A special committee comprising Louis Sterling, D. J. Blaikley, M. F. Cooksey, with officers ex-officio, was appointed to go thoroughly into the matter, and a vigorous campaign will shortly be instituted, in which members will be invited, and will doubtless be only too well pleased to co-operate.

(Continued on page 110)

GUARDSMAN RECORDS

REGISTERED



TRADE MARK

10 inch and 12 inch Lateral Cut

We can ship you *immediately*, any quantity of Records:

BANDS ORCHESTRAS INSTRUMENTAL SOLOS VOCAL

WIDE SELECTION OF CLASSICAL AND POPULAR TITLES

The Latest American and British works are promptly recorded by the best artists of the day.

Get a trial lot at once (your regular orders will follow) and secure yourself for the coming season's trade.

Apply for Lists and Prices to INVICTA RECORD COMPANY, Ltd.

Cables: Duarrab, London

1 New Inn Yard, London, E. C., England

FROM OUR LONDON HEADQUARTERS—(Continued from page 109)

"Winner" Record Sales Forging Ahead

The line of demarcation between what used to be termed the season as distinct from the slack summer trade has become almost unrecognizable since the need for gramophonic music to entertain the troops stimulated trade to an abnormal extent throughout every month—every week of the year. Military requirements in this regard are continuous, the demand for machines and records being almost as great in the summertime as during winter.

It is not therefore surprising to learn that most record companies have participated to a gratifying degree in this extra trade, and in consequence it is somewhat beside the point to refer to the "coming" season's sales prospects. There is, of course, a difference, as applied to the purely civilian purchases, and in that respect only can one be permitted to express an opinion.

The Winner Record Co. is "all out" this year for a larger trade than ever. Business, I learn, has been exceptionally good throughout the summer months, and some increment thereof was not entirely unexpected at this period. To grapple with the situation output will need to be considerably augmented, if that be possible, and to that end a special effort has been made with, at the time of writing, every probability of success. This is not altogether confined to output. The artistic side has also received attention, the company being ever ready and at all times willing to put into effect any development in the direction of improved production that practical results justify. Thus, in a measure, do we find the secret of "Winner" recording quality and perfective results in productive effort.

"His Master's Voice" Special Issues

Special issues are announced by the Gramophone Co., Ltd., of records of London's two latest successes—"Tails Up" and the "Soldier Boy." We have yet to hear these productions, but from all accounts as to the attractiveness of the music are predisposed in their favor. The music is described as bright and of that character which quickly determines the success of a play. These two productions have therefore achieved an almost instantaneous popularity, and its effect is sure to enhance the value from a sales viewpoint of the excellent series of records now before the trade. "Tails Up" is drawing big audiences at the Comedy Theatre, and the "Soldier Boy" is equally busy at the Apollo. In each case there are four double "His Master's Voice" records comprising the choice of the vocal and instrumental items, all recorded by first-class artists.

Death of Sir Herbert Marshall

The musical world has heard with keen regret of the death in his sixty-seventh year of Sir Herbert Marshall, head of the great piano and player firm of Sir Herbert Marshall & Sons, Ltd., Leicester and London. The influence of his efforts for the advancement of music was

felt far beyond his native town of Leicester, where he founded the Leicester Philharmonic Society. Sir Herbert was honorary representative of the Royal Academy and Royal College of Music. In 1896 he was Mayor of Leicester, in 1905 he received the honor of Knighthood, and in the parliamentary elections of 1910 Sir Herbert twice unsuccessfully contested the Market Harboro Division. His loss will be widely felt.

Some New Board of Trade Rulings

At a recent meeting of the Association of Gramophone & Musical Instrument Manufacturers & Wholesale Manufacturers it was reported that on July 31 the Board of Trade informed the Industry Committee that the recommendation for permits would be necessary with regard to imports from the United States, and that the goods required by the gramophone trade could not be considered important enough to warrant the granting of such permits. The following protest to the Board of Trade on August 15 renewed the concession of five tons per month to cover all imports to those firms entitled to import licenses. It is, however, necessary to first apply to the Licensing Department, 17 Little Titchfield street, London, for a permit to purchase.

The Association Committee was also informed by the Board of Trade that mouth organs could not be imported from Japan and Switzerland except through the Army and Navy Canteen Board.

The ration of steel for the gramophone springs and needles expired on August 21, and a new ration has been applied for, the committee having approached the Board of Trade for permission to import needles from Japan. This matter is now under consideration.

French Prohibited Exports

The Board of Trade has recently published a list of goods, the exportation of which from France is prohibited. Among the items on the list we notice discs and rolls for gramophones and phonographs.

"Aladdin" Needles

M. Hirst & Co., of Grove road, Willesden, London, announce under the above name the issue of needles that will play for several records. Any sound introduction of this character at this period when needles are somewhat scarce will doubtless be accorded a good welcome by the trade.

The Opening of the Concert Season

The opening of the promenade concert season at the Queen's Hall draws attention to the work of the indefatigable Sir Henry J. Wood as the orchestral leader. His fine orchestra is of course the predominant attraction of the "proms," and its conductor is always looked to with unflinching confidence to provide music of a kind that will uphold the reputation of London. It is a high ideal, but Sir Henry Wood has never failed his public yet nor is he likely to do so. He gives his audiences what he knows

REX GRAMOPHONE CO.

are making a Specialty of

EXPORT

in

Horn, Hornless & Portable Disc Machines**REX GRAMOPHONE CO. 2 Elizabeth Place
Rivington Street, LONDON, E.C. 2**

Cable Address "Lyrecodisc, London"

Enquiries Solicited

they like, with a soupçon of new music. Among the works to be performed during the opening nights is Sir Henry's own impressive arrangement of Rachmaninoff's tragic Prelude in C sharp minor, and it is expected that a little later we shall be given those masterly Granados' Five Spanish Dances. It is the reflection of this same careful study of his public's tastes in the selection of works for performance that has resulted in such a stupendous success for Sir Henry Wood's records on Columbia, for which house he records exclusively.

Columbia Graphophone on a Theatrical Tour

We understand that Horace Hunter recommences a lengthy new provincial tour this month with his dramatic sketches "Under Suspicion" and "The Years Between." In the latter, it may be recalled, a tense situation hinges upon a gramophone and a record of "I Hear You Calling Me," probably the only legitimate and plausible situation of the kind ever set on the stage. For this Mr. Hunter uses, as he did before, a Columbia Graphophone, the record being sung by Miss Violet Essex specially for the production.

The War Adventures of a Decca Dulcephone

Few machines, I should imagine, have been in such tight corners as the battle-scarred Decca recently returned to the makers, Barnett Samuel & Sons, Ltd., this city, direct from service. For over two years it has been the medium of providing entertainment, an almost human link with home, for many brave fellows, some of whom have since made the great sacrifice. Its record of service is inscribed on the case, such terribly historic names as Laventie, Ypres, Somme, Cambrai, and others, testifying to the many times it has been under enemy fire. And yet, through it all, a not particularly serious bullet wound was the only result, though quite ineffective in putting it out of action. The wear and tear alone is the cause of its homecoming. It is a tribute to all Deccas, and this one in particular, that they are so splendidly constructed as to withstand for so long a period the destructive conditions of war life and usage, as did the warrior under mention, which, by the way, is still capable of an acceptable tune. It now reposes in the great British war museum, where, as the chairman said in his letter of acknowledgment, "it will be carefully preserved for all time as a national relic."

We regret to learn of the death on September 2 of J. Harris, the principal of the well-known factors, R. B. & H. Harris, of 35 South Anne street, Dublin.

EDISON BELL**WINNER**
TRADE MARK
GRAMOPHONE RECORDSCABLE
"PHONOKINO,
LONDON"**ARE THE GREATEST VALUE FOR MONEY PRODUCED IN GREAT BRITAIN**

TEN INCH

DOUBLE SIDED

NEEDLE CUT

PLAY ON ALL GRAMOPHONES**Catalogue contains 4000 Titles by the Premier Artistes, Instrumentalists, Orchestras and Bands of the British Empire**

DEALERS PREPARED TO DO BUSINESS ARE INVITED TO COMMUNICATE WITH

Proprietors and Manufacturers, J. E. HOUGH, Ltd., 62 Glengall Road, London, S. E. 15, England

LATEST PATENTS RELATING TO TALKING MACHINES AND RECORDS

WASHINGTON, D. C., October 8.—REPEATING AND STOPPING ATTACHMENT FOR DISC PHONOGRAPHS.—Frank H. Adams, Cleveland, O. Patent No. 1,275,823.

The objects of this invention are, first, to enable a disc phonograph machine to automatically repeat the playing of records indefinitely; and second, when desired, to enable the machine to automatically stop itself when the playing of a record has been completed.

In the drawing Figure 1 is a plan view of a disc phonograph machine equipped with the invention. Fig. 2 is a front elevation of so much of said machine as is necessary to show said invention. Fig. 3 is a bottom view of the track arm and connections. Fig. 4 is a side elevation thereof. Fig. 5 is a perspective view

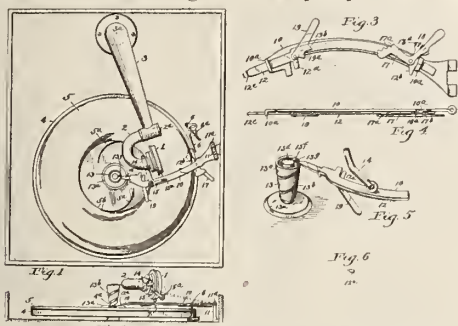

showing the track arm lifter, and a part of the track arm and its adjuncts adjacent to said lifter. Fig. 6 is an end view of the turned down end of slide 12.

SOUND BOX.—Frederick W. Schaefer, Cranford, N. J., assignor to the Aeolian Co., New York. Patent No. 1,275,764.

This invention relates to sound boxes for talking machines, and in particular to those of the so-called convertible or universal type, which may be used to play records of both the vertical and the lateral-cut forms.

Under ordinary conditions it is customary, due to the difference in the way in which the sound waves are recorded in the grooves, either to shift the sound box bodily from one position to another when changing from one type of record to a record of different type, or else to utilize a stylus bar having a shiftable stylus holder which may be moved from one position to another, according to the type of record to be played. In certain other forms of universal sound boxes, two separate stylus holders are provided, one for use in playing each type of record, each holder being furnished with its own screw or other clamp to retain the stylus in place in the socket or bore of the holder. All of these constructions require appreciable manipulation before playing can be commenced, and some of them are comparatively expensive to manufacture.

The present invention has for its primary object to simplify the construction above described, by avoiding all of the preliminary manipulation and reducing the number of neces-

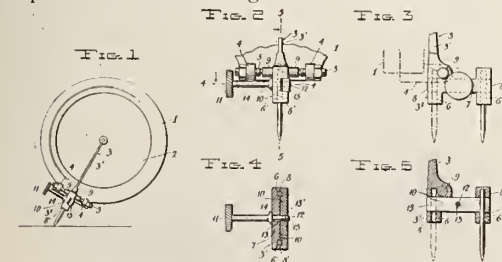

sary parts without, however, in any way impairing the effectiveness of the former constructions. According to the illustrated embodiment of the invention, a substantially right-angled stylus bar is provided, the lower arm of which is made H-shaped and is both widened and thickened to permit the formation in its vertical members of a pair of spaced, parallel sockets, one for use when playing vertical-cut records and the other

for lateral-cut records. The cross-piece of this arm has its rear face cut away, the cut extending across the rear faces of the vertical members, so as to intersect both sockets, and being designed to receive in it a cross-bar or clamp, the ends of which overlie the sockets. The bar is thereby enabled to retain a stylus in either socket, its movements incidental to the engagement or release of the stylus being effected by means of a screw which is engaged with the central portion thereof.

Figure 1 is a face view of a sound box equipped with the improved stylus bar. Figs. 2 and 3 are enlarged, fragmental detail views of the clamp portion of the bar, Fig. 2 being a face view, and Fig. 3 an edge view. Figs. 4 and 5 are enlarged horizontal and vertical sections of the clamp, taken, respectively, on lines 4—4 and 5—5 of Fig. 2.

PHONOGRAPH.—Newman H. Holland, West Orange, N. J., assignor to New Jersey Patent Co., same place. Patent No. 1,275,257.

This invention relates to phonographs and more particularly to phonographs of the business or commercial type. It has for its primary object to provide improved means whereby the reproducer stylus of the phonograph can be moved or spaced back for the purpose of causing the repetition of any portion of the record whenever the operator who is transcribing the record so desires. This object is attained by means of a construction wherein the reproducing stylus can be shifted back over a part of the record to repeat the same without the necessity of being lifted from the record, this construction greatly facilitating the rapidity and efficiency of operation of the back spacing device.

A further object of the invention is to provide an improved construction wherein the controlling means for the back spacing mechanism

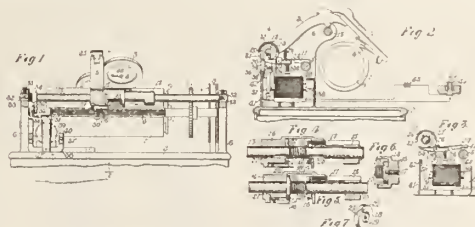

may be positioned at a convenient position for actuation by the transcriber while the latter is operating the typewriting machine, the preferred position for this purpose being adjacent the keyboard of said machine.

Figure 1 is a rear elevation partly in section of said embodiment of the invention; Fig. 2 is a transverse vertical section taken on the line 2—2 of Fig. 1; Fig. 3 is a view partly in vertical section and partly in elevation of a detail of construction; Fig. 4 is a vertical sectional view taken on the line 4—4 of Fig. 2; Fig. 5 is a view similar to Fig. 4 showing the same parts in a slightly different position; Fig. 6 is a view partly in horizontal section and partly in plan of a detail of construction; and Fig. 7 is a perspective view of one of the elements of the back spacing means.

SOUND MODIFYING MEANS.—Alcorn Rector, Cleveland, O. Patent, No. 1,275,089.

This invention relates to sound reproducing devices used with and which form a part of what are commonly known as talking machines; and the object thereof is to provide an auxiliary mechanism or device adapted to co-operate with the vibrating stylus present in sound reproducing devices of the type or kind in common use, and the purpose of which is to eliminate or reduce to a minimum the grating, scratching, and other objectionable noises foreign to the selection recorded upon the record and intended to be reproduced, but which noises are nevertheless emitted in the use of most reproducers; the elimination of the objectionable

noises, however, being accompanied by no material reduction in the volume or change in the quality of the selection reproduced.

In various prior devices designed to improve the quality of the sound reproduced by neutralizing noises foreign to the selection to be rendered, the vibratory movement of the stylus has ordinarily been opposed or dampened by a spring member acting in opposition to the movement of the stylus through a soft, yielding, or resilient member; and in such devices such modification or reduction of the objectionable noises referred to as has been secured has been accompanied by a considerable reduction of the volume of the selection intended to be reproduced, as well as also by a more or less undesirable change in the quality of the tone produced. In the device, however, the movement of the vibrating stylus is communicated to a member adapted to partake of the movement of the stylus or stylus-carrying member through a non-yielding connection, engagement, or contact between the two and, while the objectionable noises hereinbefore referred to are eliminated or reduced to a minimum, particularly those of high pitch which are the more troublesome, there is no concomitant material reduction in the volume of the sound produced, or change in the quality of the tone of the selection recorded and reproduced.

In the drawings Figure 1 is a view showing the device in end elevation and as attached to

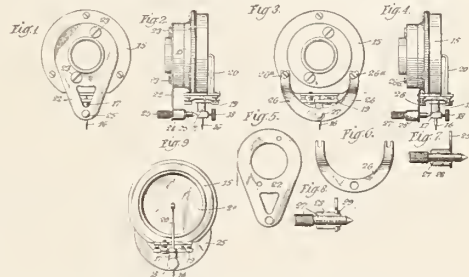

the diaphragm casing of a common type of sound reproducing device. Fig. 2 is a view showing a side elevation of the elements shown in Fig. 1; Fig. 3 is a view showing an end elevation of a modified form of the device, as seen from a position to the left of Fig. 4; Fig. 4 is a view showing the elements shown in Fig. 3 in side elevation; Fig. 5 is a view showing the resilient support of the form of the device shown in Figs. 1 and 2, detached; Fig. 6 is a similar view showing the form of resilient support employed in the form of the invention shown in Figs. 3 and 4; Figs. 7 and 8 are fragmentary sectional views showing the threaded sleeve carried by the resilient support of the device, and the adjustable member thereof carried by said sleeve; Fig. 9 is a view showing an end elevation of the form of the device shown in Figs. 3 and 4, as seen from a position to the right of Fig. 4.

TALKING MACHINE RECORD.—Thor Raje, Los Angeles, Cal. Patent No. 1,275,087.

This invention relates to talking machines and particularly to an improved form of record for use in connection with such machines and the primary object is to provide a record of such form that a greater length of groove may be provided, thus permitting the rendition of compositions of greater length than usual on other types of records.

Talking machines of the well-known types are usually adapted for playing records of the disc and cylinder type, the disc machines having grown into more general favor in the recent years. The cylinder records, which are usually employed in the cheaper machines and in offices and places of business, are relatively short and small in diameter, and the length of the compositions which may be reproduced thereon are necessarily limited. The record grooves in the disc type of records decrease in diameter gradually as the reproduction of the composition progresses and thus, the speed of the disc being always the same, it is obvious that the groove speed will be greater near the periphery of the disc than at the inside and will gradually decrease as the needle of the repro-

(Continued on page 112)

LATEST PATENTS RELATING TO TALKING MACHINES AND RECORDS—(Continued from page 111)

ducing element moves toward the center of the disc. This, of course, causes a corresponding change in the speed of the composition, and in many cases is unsatisfactory.

Referring to the drawings, Figure 1 is an end view of one of the improved records in position on the drum. Fig. 2 is a fragmentary longitudinal section of several records in position on the drum and arranged for continuous or

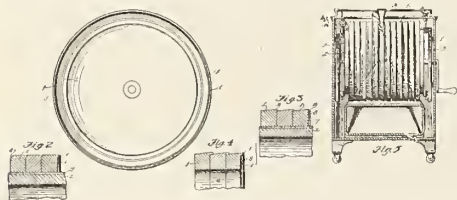

series playing. Figs. 3 and 4 are views similar to Fig. 2 but showing different forms of records and modifications thereof which may be optionally employed in some instances to greater advantage than the form shown in Fig. 2. Fig. 5 is a longitudinal sectional elevation of a talking machine arranged for playing the records set forth in this application.

PHONOGRAPH.—Harry Adams, United States Navy. Patent No. 1,274,361.

This invention relates to a toy phonograph or sound producing device and the object of the invention is to produce a toy phonograph which is novel in construction and operation, simple to operate and portable and also light in weight so that a child can readily handle and operate the device, and a further object of the invention is to produce a toy phonograph which can be manufactured at a very small cost.

Referring to the drawings Figure 1 is a side elevation of the phonograph; Fig. 2 is a front elevation of Fig. 1; Fig. 3 is a detached view

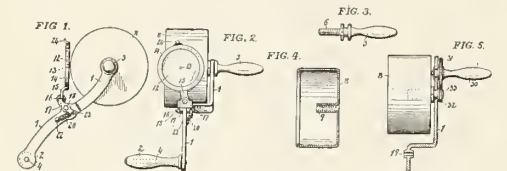

of the spindle upon which the record cylinder is mounted; Fig. 4 is a sectional view of the record cylinder; and Fig. 5 is a sectional view showing mechanism for increasing the speed of the record cylinder.

PHONOGRAPH.—John M. Waddell, Greenfield, O. Patent No. 1,274,640.

An object of this invention is to produce an improved phonograph in which improved instrumentalities are employed for modifying the intensity of the sound waves without producing muffled effects, while simultaneously serving ornamental and useful purposes in an article of furniture other than a phonograph cabinet.

Figure 1 is a front elevation of a phonograph embodying this invention. Fig. 2 is a transverse sectional elevation taken on the line 2—2 of Fig. 1. Fig. 3 is a plan view of the phono-

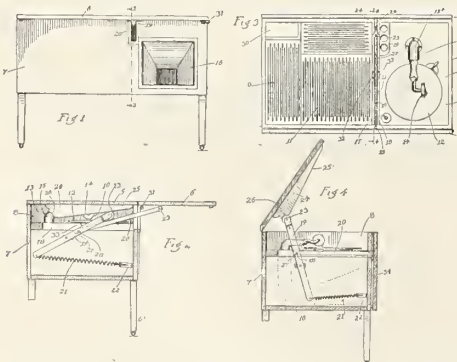

graph embodying this invention, the lid being completely raised. Fig. 4 is a transverse sectional view taken on the line 4—4 of Fig. 3, the lid being shown in normal raised position.

SOUND REPRODUCER.—Alexander N. Pierman, Newark, N. J., assignor to New Jersey Patent Co., West Orange, N. J. Patent No. 1,275,302.

This invention relates to sound reproducers of the pneumatic type, or, generally speaking, of the type in which undulations corresponding

to sound waves are impressed upon a current of any suitable moving fluid by a suitable valve operated in accordance with sound vibrations, as by connection with a reproducing stylus tracking a record groove. The principal object of the invention is to construct a reproducer having a sensitive valve of a novel character, which is operated in such a manner as to give a reproduction of sound of clear and excellent qualities and the desired degree of amplification.

Figure 1 represents a side elevation partly in section of a sound reproducer embodying the preferred form of the invention, the valve being shown in closed position; Fig. 2 is a fragmentary view similar to that of Fig. 1, showing the valve in open position; Fig. 3 is a cross section taken on line 3—3 of Fig. 1 and look-

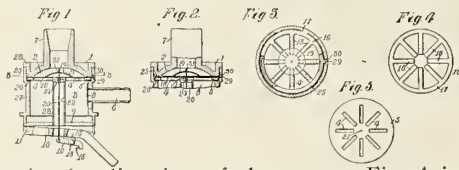

ing in the direction of the arrow; Fig. 4 is a plan view of the preferred form of valve; and Fig. 5 is a plan view of a port plate suitable for use with the valve of Fig. 4.

SOUND BOX FOR TALKING MACHINES.—Alva D. Jones, Philadelphia, Pa. Patent No. 1,275,936.

In sound boxes for talking machines as generally constructed, it is well known that the same in use frequently emit a metallic or scratchy sound accompanying the reproduction of sound from the sound reproducing tablet.

This invention consists of a novel construction of sound box wherein the principal portion thereof which co-operates with the diaphragm is constructed of a hardened and somewhat thickened wall of rubber or the like cured to a degree of hardness simulating the human throat or palate, said wall having secured thereto a metallic ring, plate or casting having thereon arms provided with bearings for the stylus bar, whereby a device is cheaply produced having peculiar recording or reproducing qualities, and wherein any surface sounds or metallic or scratchy noises are eliminated or absorbed in said hardened, thickened wall of the sound box, the resultant device having peculiar reproducing

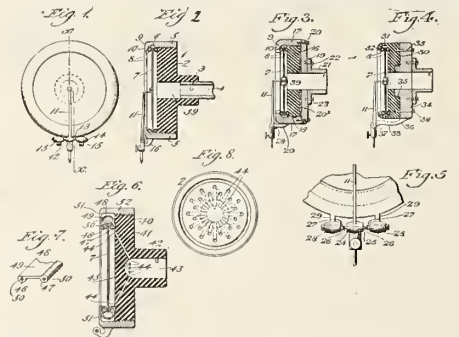

qualities which closely resemble the action of the human throat or palate in reproducing sounds.

Figure 1 represents a front elevation of a sound box embodying the invention. Fig. 2 represents a section on line x—x Fig. 1. Fig. 3 represents a sectional view of a modified form of construction embodying the principles seen in Fig. 1. Fig. 4 represents a sectional view of another embodiment of the invention. Fig. 5 represents a front elevation of Figs. 3 and 4, showing the preferred manner of mounting the stylus bar in its bearings. Fig. 6 represents a sectional view of another embodiment of the invention. Fig. 7 represents a sectional view of the gasket device seen in Fig. 6, before the same is bent into the position seen therein. Fig. 8 represents a front view of the disc of Fig. 6.

SOUND BOX.—Robert Head, New York, assignor to the Aeolian Co., same place. Patent No. 1,275,914.

This invention relates to sound boxes for talking machines, and in particular to those of the so-called convertible or universal type, which

may be used to play records of both the vertical and the lateral-cut forms.

Under ordinary conditions it is customary, due to the difference in the way in which the sound waves are recorded in the grooves, either to shift the sound box bodily from one position to another when changing from one type of record to a record of different type, or else to utilize a stylus bar having a shiftable stylus holder which may be moved from one position to another, according to the type of record to be played. In certain other forms of universal sound boxes, two separate stylus holders are provided, one for use in playing each type of record, each holder being furnished with its own screw or other clamp to retain the stylus in place in the socket or bore of the holder. All of these constructions require appreciable manipulation before playing can be commenced, and some of them are comparatively expensive to manufacture.

The present invention has for its primary object to simplify the constructions above described, by avoiding all of the preliminary manipulation and reducing the number of necessary parts without, however, in any way impairing the effectiveness of the former constructions. According to the illustrated embodiment of the invention, a substantially L-shaped stylus bar is provided, the lower arm of which

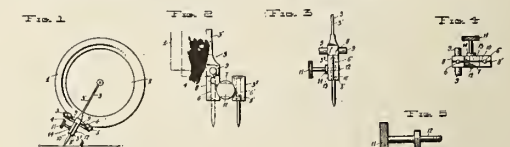

is both widened and thickened to permit the formation of a pair of spaced, parallel, vertical sockets therein, one for use when playing vertical-cut records and the other for lateral-cut records. This arm is then split vertically from end to end, so as to form two counterpart spring jaws, the plane of the split intersecting both sockets; and the arm is then fitted with a single, centrally-located clamping screw which acts to alternatively open or close the jaws, thereby releasing or securing a stylus in either playing position or both styli at the same time.

Figure 1 is a face view of a sound box equipped with the improved stylus bar. Figs. 2 and 3 are enlarged, fragmental detail views of the clamp portion of the bar, Fig. 2 being a face view, and Fig. 3 an edge view. Fig. 4 is a bottom plan view. Fig. 5 is an enlarged view of the clamping screw.

MEANS FOR RECORDING AND REPRODUCING SOUNDS.—Max Shulman, New York. Patent No. 1,278,042.

This invention consists in novel features and the objects are:

First: To provide a means for recording and reproducing sounds, which may be readily attached to the cabinets of standard sound reproducing machines.

Second: To improve the sundry details of said means for recording and reproducing sounds.

Third: To provide a ready means for producing records of sound, which may be employed for educational and other purposes.

Fourth: To have said means simple, durable and inexpensive.

In the drawings Figure 1 is a sectional elevation on the line A—B of Fig. 2 of the means

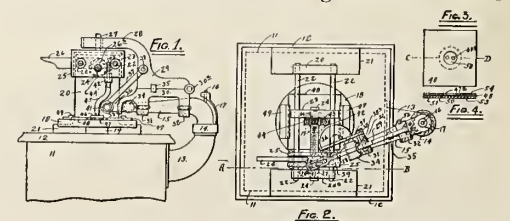

for recording and reproducing sounds, shown as connected to the cabinet of a standard machine. Fig. 2 is a plan thereof. Fig. 3 is a plan of the recording card. Fig. 4 is a cross-section of the recording card on the line C—D of Fig. 4.

RECORD BULLETINS FOR NOVEMBER, 1918

COLUMBIA GRAPHOPHONE CO.

- 7744 Ma Curly Headed Baby (Clutsm). Soprano solo, orch. accomp.
A2614 Funiculi Funicula (A Merry Heart) (Denza). Hawaiian guitar, banjo and ukulele.
A6070 Second Hungarian Rhapsody (Liszt). Philharmonic Orchestra of New York (Tschaikowsky).

MUSIC FOR THE CHILDREN'S HOUR

- A1836 Danse Macabre (Saint Saëns)...Prince's Orchestra
A1884 Dialogue For Three (J. Val Hamm). Flute, clarinet and oboe...Columbia Instrumental Trio
A7516 Father of Victory...Prince's Band
A7517 High School Cadets March...Prince's Band
A7520 Flashing Glory March...Prince's Band

VICTOR TALKING MACHINE CO.

- 18497 Everything is Peaches Down in Georgia. American Quartet
18502 Carolina, I'm Coming Back to You...Peerless Quartet
18505 Oui, Oui, Marie...Arthur Fields
18506 Oh! How I Wish I Could Sleep Until My Daddy Comes Home...Henry Burr
45155 Smiles (Roberts)...Lambert Murphy
18501 Cohen Gets Married—Humorous Monologue, Monroe Silver

EDISON AMBEROL RECORDS

- 29010 Elle ne Croyait Pas (Pure as a Flower), Mignon (Ambrose Thomas). Tenor, in French, orch. accomp.
29011 Freedom For All Forever (B. C. Hilliam). Baritone and mixed voices, orch. accomp.
29009 Kidonami la calma! (Restore Again My Peace) (F. Paolo Tosti). Baritone, in Italian, orch. accomp.
3583 Aloha Land—Hawaiian Waltz (Wallie Herzer), Waikiki Hawaiian Orch. (with Louise and Ferera)
3580 Boccaccio—Selection (Franz von Suppe). Creator and His Band
3587 Ev'rything's Funny to Me (Theo. II Northrup). Laughing song, orch. accomp.
3595 Hello, Central, Give Me No Man's Land (Jean Schwartz). Soprano, orch. accomp.
3593 If He Can Fight Like He Can Love, Good-Night Germany! (George W. Meyer). Orch. accomp.
3594 I'm Goin' to Fight My Way Right Back to Carolina (Baskette-Spiess). Tenor, orch. accomp.
3585 I'm Sorry I Made You Cry—Jazz Fox-trot (N. J. Clesi)...Earl Fuller's Famous Jazz Band
3599 In the Land o' Yamo Yamo (Funiculi Funiculi, Funicula) (Fred Fisher). Tenor and male voices, orch. accomp.
3591 Land Where the Roses Never Fade (B. D. Ackley). Baritone, orch. accomp.
3600 (a) Little Tommy Went a-Fishing (J. C. Macy); (b) The Musical Trust (Henry Hadley). Male voices, unaccomp.
3598 Mammy's Chocolate Soldier (Archie Gottler). Mixed voices, orch. accomp.
3581 Mignon Fantasia—Part I (Ambrose Thomas), American Symphony Orchestra
3582 Mignon Fantasia—Part II (Ambrose Thomas), American Symphony Orchestra
3584 Molly O Medley—Waltz for dancing, Jaudas' Society Orchestra
3590 My Old Shako (H. Trotère). Bass, orch. accomp.
3589 Nona Waltz (F. W. Vandersloot), Imperial Marimba Band
3596 Oui, Oui, Marie (Fred Fisher), Rachael Grant, Billy Murray and Chorus
3586 Rock-a-Bye Your Baby With a Dixie Melody (Jean Schwartz). Tenor, orch. accomp.
3592 Sabre and Spurs March (John Philip Sousa, Lieut. U. S. N. R. F.)...New York Military Band
3588 Sliding Sid—One-step (Abe Losch), New York Military Band
3579 There are Tears in Your Dear, Dear Eyes (William H. Perrins). Contralto, orch. accomp.
3597 When You Come Back (and You Will Come Back). There's the Whole World Waiting for You (George M. Cohan). Male voices, orch. accomp.

- 3088 Go Get 'Em—One step (Manholz), Jaudas' Society Orchestra
3089 Here Comes the Groom ("Betty") (Burt), Billy Murray
3106 Good-night, Dinny, and God Bless You (Gartlan)...George McFadden
3118 Mother ("Her Soldier Boy") (Romberg), George Wilton Ballard
3127 Sonata in C Major (Frosini). Accordion...P. Frosini

EDISON RE-CREATIONS

- 80406 Just a Baby's Prayer at Twilight (M. K. Jerome), First soprano, second soprano and alto, Homestead Trio
Lorraine (My Beautiful Alsace-Lorraine) (Fred Fisher). Tenor and Chorus...Vernon Dalhart
50472 'Round Her Neck She Wears a Yeller Ribbon (For Her Lover Who is Fur Fur Away) (Geo. Norton)...Byron G. Harlan and Chorus
50473 I'll Take You Back to Italy ("Jack o' Lantern") (Irving Berlin). Conversational duet, Ada Jones and Billy Murray
50474 Dixie Volunteers (Leslie-Ruby). Male voices, Premier Quartet
50475 Homeward Bound (Geo. W. Meyer). Tenor solo...George Wilton Ballard
I'll Come Back to You When it's All Over (Kerry Mills). Baritone and chorus.Edward Allen

PATHE FRERES PHONOGRAPH CO.

- All records in this list marked with a star (*) are for immediate release and sale.
POPULAR "HITS" OF THE MONTH
20431* Oh, How I Hate to Get Up in the Morning (Berlin). Baritone solo...Arthur Fields
20436* Smiles (Roberts). Duet, Ruth Lenox and Henry Burr
20438* A Soldier's Dream (Gay). Contralto solo, Lois Fairman
20435* Everything is Peaches Down in Georgia (Ager-Meyer)...The Farber Girls
20437* When I Get Back to My American Blighty (Fields-Morse). Baritone solo...Arthur Fields
20432 My Boy (Huhn) Contralto solo...Helen Clark
25020 Battle Hymn of the Republic (Howe). Baritone solo...Percy Hemus
52033 Sing Me to Sleep (Greene). Tenor solo, Craig Campbell
27013 Dear Old Pal of Mine (Lieut. Gitz-Rice). Tenor solo...Paul Althouse
29204 There's a Land (Allitsen) Baritone solo, Frank Oldfield
20432 My Boy (Huhn) Contralto solo...Helen Clark
25020 Battle Hymn of the Republic (Howe). Baritone solo...Percy Hemus
40137 The Trumpet Shall Sound, from "Messiah" (Handel). Baritone solo...B. Stonehill
29216 Carnival of Venice (with variations) (Arban). Cornet solo, piano accomp.
40140 Then You'll Remember Me, from "The Bohemian Girl" (Balfe)...Ackroyd Trio
20440* Djer Kiss—Waltz (Ager)...American Republic Band
29218* Sand Dunes—One-step (Gay), American Republic Band
20441* Beale Street Blues—Fox-trot (Handy), Wadsworth's Novelty Dance Orchestra
20430* The Jazz Dance—Fox-trot (Overstreet), Blake's Jazzone Orchestra
29217 The Nightingale and the Frogs (Eilenberg), Characteristic...American Regimental Band
40104 La Brabanconne—Belgian National Hymn (De-place)...Pathé Military Band
54017 The Star-Spangled Banner (Key). Tenor solo, Lucien Muratore
54018 Faust—"Salut demeure" (All Hail, Thou Dwell...Premier Quartet

(Continued on page 114)

RECORD BULLETINS FOR NOVEMBER (Continued from page 113)

ing Lowly (Gounod). Tenor solo In French, Lucien Muratore
54015 Aida—"O cieli azzurri" (Oh, Azure Sky) (Verdi). Soprano solo in Italian. Claudia Muzio
52032 Tales of Hoffman—"Doll's Song" (Offenbach). Soprano solo. Grace Hoffman
Sweet Bird that Shun't the Noise of Folly (Handel). Soprano solo. Grace Hoffman

EMERSON PHONOGRAPH CO.

THE NEW LARGE-SIZE RECORDS

Patriotic and Popular Song Hits
988 Kitchen Floor Little Me (Sgt. Irving Berlin). Baritone Solo, orch. accomp. Eddie Nelson
I Can Always Find a Little Sunshine in the Y. M. C. A. (Sgt. Irving Berlin). Tenor Solo, orch. accomp. Henry Burr
981 For Your Boy and My Boy (Van Alstyne-Kahn). Vocal Quartet, orch. accomp. Peerless Quartet
I Want to Go Back to Blighty (Walker-Davidson). Baritone Solo, orch. accomp. Greek Evans
982 Smiles (Callahan-Roberts). Baritone Solo, orch. accomp. George Beaver
You Keep Sending 'Em Over and We'll Keep Knocking 'Em Down (Mitchell-Ruby). Patriotic Solo, orch. accomp. Eddie Nelson
983 Rock-a-Bye Your Baby With a Dixie Melody (Lewis-Young-Schwartz). Baritone Solo, orch. accomp. George Beaver
Big Chief Killahun (Irving Berlin). Baritone and Tenor Duet, orch. accomp. Collins-Harlan
984 I Love to Be a Sailor (Harry Lauder). Scotch Character Song, orch. accomp. Evan Davies
I Love a Lassie (Lauder-Grafton). Scotch Polk Song, orch. accomp. Evan Davies
989 Garden of My Dreams (Buck-Stamper-Hirsch). Tenor Solo, orch. accomp. George Gordon
Till I'm Called by the Master Above (James Donahue-Ernest R. Ball). Tenor Solo, orch. accomp. Robert Bruce
990 I'm Waiting for You, Liza Jane (Creamer-Layton). Comedy Ballad, orch. accomp. Collins-Harlan
Macaroni Joe (Donahue-Dubin-Lyons-Yosco). Comic Patriotic Solo, orch. accomp. George L. Thompson
987 I Hear You Calling Me (Henry-Warren). Tenor Solo, orch. accomp. Frank Woods
Bedouin Love Song (Pinsuti-Taylor). Bass Solo, orch. accomp. Wilfred Glenn
994 The Bandolero (Leslie Stuart). Bass Solo, orch. accomp. Wilfred Glenn
Sweet and Low (Barbry). Vocal Quartet, orch. accomp. Liberty Quartet

LATEST DANCE RECORDS

991 Castle Valse Classique (Dvorak's Humoresque) (Ford T. Dabney). Xylophone Solo, orch. accomp. George Hamilton Green
Watermelon Whispers (George Hamilton Green). Fox-Trot Xylophone Solo, orch. accomp. George Hamilton Green
986 Blue Rose (Frederic Knight Logan). Waltz, Emerson Military Band
Full-O-Snap (Spencer Williams). Fox-trot, Emerson Military Band
993 When You Come Back and Bring Me a Letter From My Home Town (Medley) (Cohan-Anderson). One-step, Banjo, Piano and Saxophone. Van Eps Banta Trio
A Coon Band Contest (Arthur Pryor). One-step, Instrumental Quartet. Van Eps Banta Quartet
985 Hindustan (Wallace-Weeks). Fox-trot, Emerson Military Band
Ange D'Amour (Angel of Love) (Waldteufel-Gressinger). Waltz. Emerson Military Band
992 Sand Dunes (Byron Gay). Oriental One-step, Emerson Military Band
Shuttle Fox-Trot (C. M. Selling). Emerson Military Band

EMERSON PHONOGRAPH CO.

THE NEW SEVEN-INCH RECORDS

PATRIOTIC AND POPULAR SONG HITS
7409 When You Come Back and You Will Come Back (There's the Whole World Waiting for You) (George M. Cohan)—Patriotic solo, orch. accomp. Eddie Nelson
I Want to Be Loved by a Soldier (Fink-Silver)—Contralto solo, orch. accomp. Edith King
7410 For Your Boy and My Boy (Van Alstyne-Kahn)—Vocal quartet, orch. accomp. Peerless Quartet
I'm Going to Fight My Way Right Back to Carolina (Baskette-Spiess)—Patriotic character song, orch. accomp. Eddie Nelson
7411 A Rainbow from the U. S. A. (Mahoney-Jerome-Wenrick)—Vocal quartet, orch. accomp. Peerless Quartet
America, He's For You (Andrew B. Sterling)—Patriotic solo, orch. accomp. Robert Rice
7412 The Yanks Are At It Again (Brown-Cowan)—Patriotic solo, orch. accomp. (Bud) Bernie
When Uncle Joe Steps Into France (Grossman-Winkle)—Patriotic character song, orch. accomp. Collins and Harlan
7413 Garden of My Dreams (Buck-Stamper-Hirsch)—Tenor solo, orch. accomp. George Gordon
Good Night, Little Girl, Good Night (Hays-Macy)—Tenor solo, orch. accomp. Robert Rice
7414 I Love to Be a Sailor (Harry Lauder)—Scotch character song, orch. accomp. Jock Simpson
I Love a Lassie (Lauder-Grafton)—Scotch folk song, orch. accomp. Jock Simpson
7415 What An Army of Men We'd Have (If They Ever Drafted the Girls) (Piantadosi-Glogau)—Comedy song, orch. accomp. Ben Linn
Down in the Jungle Land (Fields-Morse)—Tenor and baritone duet, orch. accomp. Collins and Harlan

DANCE HITS

7416 Hindustan (Wallace-Weeks)—Fox-trot, Emerson Military Band
Tiger Rose Waltzes (Reid-DeRose), Emerson Military Band
7417 Rose Room (Art Hickman)—Fox-trot, Emerson Military Band
Ange D'Amour (Angel of Love) (Waldteufel-Gressinger)—Waltz. Emerson Military Band
7418 Blue Rose Waltz (Frederic-Knight-Logan), Emerson Military Band
Full-Of-Snap (Spencer-Williams)—Fox-trot, Emerson Military Band

LATEST "OKEH" RECORDS

1078 Flow Gently Sweet Afton (Burne-Spilman). Tenor solo, orch. accomp. Reed Miller
Forgotten (Wulschner-Cowles). Baritone solo, orch. accomp. Frederic Wheeler
7006 Tosca—"E lucevan le stelle" (The Stars Were Shining) (Puccini). Tenor solo, orch. ac-

comp. George Lambert
Faust—"Dio possente" (Even Bravest Heart) (Gounod). Orch. accomp. Filippo Antonio
1077 A Dream (Cory-Bartlett). Orch. accomp. George Lambert
A Perfect Day (Carrie Jacobs-Bond). Orch. accomp. Marie Morrisey
1079 I Hear You Calling Me (Harford-Marshall). Orch. accomp. Charles Hart
Happy Days (Thomson-Strelzki). Orch. accomp. Marie Morrisey
1080 In Old Madrid (Troterre). Orch. accomp. Frederic Wheeler
Thy Sentinel Am I (Oxenford-Watson). Orch. accomp. Frank Croxton
1081 The Moon Has Raised Her Lamp Above (Benedict). Orch. accomp. Hart and Phillips
Asleep in the Deep (Lamb-Petrie). Orch. accomp. Frank Croxton
1082 The Sweetest Story Ever Told (Stults). Orch. accomp. Marie Morrisey
The Skylark's Song (Bennett-Buck). Orch. accomp. Dudley Buck
1083 Where is My Boy To-night (Lowry). Orch. accomp. Frederic Wheeler
The Vacant Chair (Washburn-Boot). Orch. accomp. Meyers and Gillette
1085 I Want to Learn to Dance, from "The Kiss Burglar" (MacDonough-Hubbell). Orch. accomp. Sam Ash
When I'm Looking at You, from "Ziegfeld Follies, 1918" (Buck Stamper). Orch. accomp. Irving Kaufman
1084 Bring Me a Rose (Shisler). Orch. accomp. Harry Ellis
The Night Nursery (Kelly-Arundale). Orch. accomp. Henry Burr
1086 Smiles, from "Passing Show, 1918" (Callahan-Roberts). Orch. accomp. Lenox and Kent
Since I Met Wonderful You, from "The Kiss Burglar" (MacDonough-Hubbell). Orch. accomp. Sam Ash
1087 When I Get Back to My American Blighty (Fields-Morse). Orch. accomp. Arthur Fields
Tim Rooney's at the Fightin' (Flynn). Orch. accomp. Charles Hart
1088 Roses of Picardy (Weatherly-Wood). Orch. accomp. Joseph Phillips
When We Meet in the Sweet Bye and Bye (Murphy). Orch. accomp. Sterling Trio
1089 A Soldier's Reverie (Arthur Hadley). Orch. accomp. Joseph Phillips
When the Sun Goes Down in Flanders (Pleeson-Von Tilzer). Orch. accomp. Charles Hart
1090 A Rainbow from the U. S. A. (Mahoney-Jerome-Wenrick). Orch. accomp. Peerless Quartet
While the Incense is Burning (Smith). Orch. accomp. Joseph Phillips
1091 My Angel of the Flaming Cross (Gay). Orch. accomp. Greek Evans
There's a Picture in My Old Kit Bag (Al Sweet). Orch. accomp. Henry Burr
1092 Uncle Sammy (Holzmann). Orch. accomp. Arthur Fields
She'll Be Waiting When You Come Back Home (Rega-Farran and Chiaffarelli). Orch. accomp. Sterling Trio
1094 Good-bye, Mother Machree (Brennan-Hall). Orch. accomp. Harry McClaskey
Oh, Moon of the Summer Night (Flynn). Orch. accomp. Harry Ellis
1095 After You've Gone (Creamer-Layton). Orch. accomp. Irving Kaufman
The Pickaninny's Paradise (Ehrlich-Osborne). Orch. accomp. Sterling Trio
1096 Everything is Peaches Down in Georgia (Clarke-Ager-Meyer). Orch. accomp. Collins and Harlan
Lovin' (Warfield). Orch. accomp. Ada Jones
1097 Florida Moon (Heagney). Orch. accomp. Sterling Trio
Wondrous Eyes of Araby (Brown-Spencer). Orch. accomp. Harvey Hindermeyer
1098 Why Do They Call Them Babies (Harriman-Egan). Orch. accomp. Elaine Gordon
An East Side Restaurant Scene (Geo. L. Thompson). Trap effects. George L. Thompson
1099 I'm Gonna Pin a Medal on the Girl I Left Behind (Intro. Rock-a-Bye Baby with a Dixie Melody) (Berlin-Schwartz). Fred Van Eps Quartet
The Missouri Waltz (Logan-Eppel). Orch. accomp. F. Wheeler Wadsworth
1100 Just Bye (Wadsworth-Arden). All Star Trio
When You Come Back (Cohan-Anderson). (Intro. Bring Me a Letter from My Old Home Town). Fred Van Eps Quartet
1103 Moments Musicaux—Valse Badinage (Schubert-Liadou). Paul Eisler
Romance—Op. 45, No. 1 (Alfred Grunfeld), Paul Eisler
1104 Rubinstein Melodie—Op. 3, No. 1 (Rubinstein). Piano accomp. Vladimir Dubinsky
Polonaise (Albert Chiaffarelli). Orch. accomp. Albert Chiaffarelli
1105 The American Rose (Victor Herbert). The Park Instrumental Quartet
Melodie—Op. 18, No. 1 (Moszkowski), The Park Instrumental Quartet
1101 Smiles (Robert), from "The Passing Show, 1918". Orch. accomp. F. Wheeler Wadsworth
Djer Kiss (Dear Kiss) (Ager). Band
1102 Prestissimo in G Major, from Verdi's Strong Quartet in G Major (Verdi). Berkshire String Quartet
Minuetto in G Minor, from Hayden's String Quartet No. 34 (Haydn). Berkshire String Quartet
1093 I'm Goin' to Fight My Way Right Back to Carolina (Baskette-Spiess). Orch. accomp. Kaufman Brothers
You'll Find Old Dixieland in France (Clarke-Meyer). Orch. accomp. Arthur Fields

EMPIRE TALKING MACHINE CO.

PATRIOTIC SONGS AND POPULAR HITS

6221 Liberty Bell (Mohr). Orch. accomp. Empire Male Quartet
Keep the Home Fires Burning (Novella). Orch. accomp. Empire Male Quartet
6222 Soldier's Farewell (Kinkle). Orch. accomp. Empire Male Quartet
Good-Bye, Little Girl, Good-Bye (Edwards). Solo, orch. accomp. David Irwin
6223 Keep Your Head Down, Fritzic Boy (Gent-Gitz-Rice). Solo, orch. accomp. Arthur Fields
Frenchy (Conrad). Solo, accordion accomp. Arthur Fields
6224 I Miss That Mississippi Miss That Misses Me (Wendling). Empire Male Quartet
When We Meet in the Sweet Bye and Bye (Murphy). Orch. accomp. Sterling Trio
6225 Oui, Oui, Marie (Wee, Wee, Marie) (Fisher). Solo, orch. accomp. Arthur Fields
I Hate to Lose You (Gottler). Orch. accomp. Peerless Quartet
6226 Hush a Bye, Ma Baby (Logan-Eppel). Duet, orch. accomp. Campbell and Burr
All I Want Is a Cottage, Some Roses and You (Harris). Campbell and Burr



Where Dealers May Secure

COLUMBIA

Product

Ready, Full Stocks, and Prompt Deliveries from Convenient Shipping Centers all over the United States.

Distributors

- Atlanta, Ga., Columbia Graphophone Co., 63 N. Pryor St.
Baltimore, Md., Columbia Graphophone Co., 16 South Howard St.
Boston, Columbia Graphophone Co., 137 Federal St.
Buffalo, N. Y., Columbia Graphophone Co., 737 Main St.
Chicago, Ill., Columbia Graphophone Co., 14 N. Michigan Ave.
Cincinnati, O., Columbia Graphophone Co., 427-429 W. Fourth Ave.
Cleveland, O., Columbia Graphophone Co., 1375 Euclid Ave.
Dallas, Tex., Columbia Graphophone Co., 1011 Elm St.
Denver, Colo., Columbia Stores Co., 1608 Glenarm Place.
Detroit, Mich., Columbia Graphophone Co., 401 Woodward Ave.
Indianapolis, Ind., Columbia Graphophone Co., 207-217 W. Washington St.
Kansas City, Mo., Columbia Graphophone Co., 1027 McGee St.
Los Angeles, Cal., Columbia Graphophone Co., 745 S. Broadway.
Minneapolis, Minn., Columbia Graphophone Co., 412-414 Nicollet Ave.
New Haven, Conn., Columbia Graphophone Co., 206 Meadow St.
New Orleans, La., Columbia Graphophone Co., 517-525 Canal St.
New York City, Columbia Graphophone Co., 55 Warren St.
Omaha, Neb., Schmoller & Mueller Piano Co.
Philadelphia, Pa., Columbia Graphophone Co., 210 N. Broad St.
Pittsburgh, Columbia Graphophone Co., 632-640 Duquesne Way.
Portland, Me., Columbia Graphophone Co., 43 Exchange St.
Portland, Ore., Columbia Graphophone Co., 429-431 Washington St.
Salt Lake City, Utah, Columbia Stores Co., 221 South West Temple.
San Francisco, Cal., Columbia Graphophone Co., 130-150 Sutter St.
Seattle, Wash., Columbia Graphophone Co., 911 Western Ave.
Spokane, Wash., Columbia Stores Co., 818 Sprague Ave.
St. Louis, Mo., Columbia Graphophone Co., 1127 Pine St.
Tampa, Fla., Tampa Hardware Co.

Headquarters for Canada:

Columbia Graphophone Co., 54-56 Wellington St., West, Toronto, Ont.

Executive Office

COLUMBIA GRAPHOPHONE CO. Woolworth Building New York

6227 Way Down Home (Fröst). Orch. accomp. Empire Male Quartet
Where the Morning Glories Grow (Whiting-Kahn-Egan). Orch. accomp. Empire Quartet
STANDARD VOCAL SELECTIONS
6228 Little Grey Home in the West (Lohr). Solo, orch. accomp. Ira Allen
Can't You Hear Me Callin', Caroline? (Roma). Solo, orch. accomp. Ben Pigriuh
6229 Love's Old Sweet Song (Molloy). Contralto, Hawaiian accomp. Una Drake
Whispering Hope (Hawthorne). Duet, orch. accomp. Jean Sterling and Una Drake
HAWAIIAN SELECTIONS
6230 I Want to Go Back to Honolulu (Cunha-Warren). Solo, ukulele accomp. Alfred Alexander
On the South Sea Isle (Von Tilzer). Ukulele accomp. Sterling Trio
6231 Ua Like, Noa Like (Sweet Constaney). Hawaiian guitars. Louise and Ferera
Hula Medley. Hawaiian Guitars. Louise and Ferera
DANCE AND BAND SELECTIONS
6232 U. S. Boy Scouts Official March (Ellsworth). Empire Military Band
(Naval Reserve March (Souza). Empire Military Band
6233 Smiles (Roberts). Fox-trot. Empire Military Band
Moments of the Dance (from "Head Over Heels") (Kern). One-step. Empire Military Band
6234 The Darktown Strutters' Ball (Rossiter). Fox-trot. Empire Military Band
The Tickle Toe (from "Going Up") (Hirsch). One-step. Empire Military Band
6235 Indianola (Henry-Ovinas). Fox-trot. Empire Military Band
Have You Seen the Ducks? (from "Hi-Tchy Koo") (Goetz). One-step. Empire Military Band

Some Leading Jobbers of Talking Machines in America

1856 **WURLITZER** 1916

VICTOR
DISTRIBUTORS
VICTORS EXCLUSIVELY

We make a specialty of getting the order out on time—every time.

The Rudolph Wurlitzer Co.
CINCINNATI AND CHICAGO
Two points of supply; order from the nearer

TEST IT. 

OUR VICTOR

Record Service

has a reputation for efficiency.
Suppose you try it.

E. F. DROOP & SONS CO.
1300 G. STREET, WASHINGTON, D. C.
231 N. HOWARD STREET, BALTIMORE, MD



YAHR & LANGE DRUG CO.
MILWAUKEE, WIS.

Wholesale Distributors for

THE INSTRUMENT OF QUALITY

Sonora
CLEAR AS A BELL 

in Wisconsin
and Upper Michigan

W. J. DYER & BRO.
NORTHWESTERN DISTRIBUTORS

OF THE

VICTOR
Machines, Records and Supplies

 Shipped Promptly to all Points in the Northwest

STARR Phonographs and GENNETT Records

Complete Stock and REAL Service

Crafts-Starr
PHONOGRAPH CO.

Factory Distributors
218-220 NORTH SECOND STREET, RICHMOND, VIRGINIA
Write for Dealers' Proposition

Smith, Kline & French Co.
PHILADELPHIA

Wholesale Distributors for

THE INSTRUMENT OF QUALITY

Sonora
CLEAR AS A BELL 

In PENNSYLVANIA, NEW JERSEY
and DELAWARE

Hillman & Son Phonograph Co.
Wheeling, West Virginia

Exclusive Wholesale Distributors for West Virginia and Virginia

THE INSTRUMENT OF QUALITY

Sonora
CLEAR AS A BELL 

All models shipped promptly from our large warehouse, 1126 Main Street
Diamond Needles and Sapphire Needles for Sale

Strevell-Paterson Hdw. Co.
Wholesale Distributors

for
Utah, Idaho, Colorado, Wyoming
and New Mexico

THE INSTRUMENT OF QUALITY

Sonora
CLEAR AS A BELL 

Complete Stock on Hand at All Times
SALT LAKE CITY UTAH

C. L. Marshall & Co.
Wholesale Distributors
for Michigan

THE INSTRUMENT OF QUALITY

Sonora
CLEAR AS A BELL 

The Ohio Sales Company, Inc.
Wholesale Distributors
for Ohio

810-11 EMPIRE BLDG., DETROIT, MICH.

Mickel Bros. Co.

Omaha, Nebraska
Des Moines, Iowa

Victor Distributors

Southern Victor Dealers
Largest Stock VICTROLAS and RECORDS.
Prompt Shipment and Low Freight Rates.

WALTER D. MOSES & CO.
Oldest Music House in Virginia or North Carolina.
RICHMOND, VA.

OLIVER DITSON COMPANY
BOSTON

Largest VICTOR Talking Machine Distributors East of Chicago.
Creators of "The Fastest Victor Service." Let us tell you more about our service.

Sherman, May & Co.

San Francisco, Los Angeles, Portland, Seattle, Spokane
PACIFIC COAST DISTRIBUTORS OF
VICTOR PRODUCTS

The PERRY B. WHITSIT CO.
Distributors of
Victrolas and Victor Records
COLUMBUS, OHIO

ROUNTREE-CHERRY
RICHMOND VIRGINIA

Wholesale Distributors for

THE INSTRUMENT OF QUALITY

Sonora
CLEAR AS A BELL 

YOU
Above all must be satisfied!

IN NORTH AND SOUTH CAROLINA

The Electric Supply & Equipment Co.
Exclusive Wholesale Distributors for
Southern New England

THE INSTRUMENT OF QUALITY

Sonora
CLEAR AS A BELL 

Complete stocks carried in Boston and Hartford

Little Bldg. 103 Allyn St.
BOSTON, MASS. HARTFORD, CONN.

Have You Noted the Growth of This Department?

Special Rates for Jobbers' Directory on Application

During the past six months this Jobbers' Directory has grown steadily in importance. It affords progressive jobbers an opportunity to keep their names before the dealers consistently and regularly, and provides representation in the Jobbers' Directory of the publication which is the recognized authority of the industry.
Join the progressive jobbers on this page next month.

Victor Exclusively
EASTERN TALKING MACHINE CO.
177 Tremont Street, Boston
VICTOR DISTRIBUTORS

THE NEW EDISON



A Master Product of A Master Mind

JOBBER'S OF THE NEW EDISON, EDISON RE-CREATIONS, THE NEW EDISON DIAMOND AMBEROLA AND BLUE AMBEROL RECORDS

CALIFORNIA Los Angeles—Edison Phonographs, Ltd. San Francisco—Edison Phonographs, Ltd.	LOUISIANA New Orleans—Diamond Music Co., Inc.	MASSACHUSETTS Boston—Pardee-Ellenberger Co.	MICHIGAN Detroit—Phonograph Co., of Detroit.	MINNESOTA Minneapolis—Laurence H. Lucker.	MISSOURI Kansas City—The Phonograph Co. of Kansas City. St. Louis—Silverstone Music Co.	MONTANA Helena—Montana Phonograph Co.	NEBRASKA Omaha—Shultz Bros.	NEW JERSEY Paterson—James K. O'Dea (Amberola only).	NEW YORK Albany—American Phonograph Co.	NEW YORK New York—The Phonograph Corp. of Manhattan. Syracuse—Frank E. Bolway & Son, Inc. W. D. Andrews Co. (Amberola only.) Buffalo—W. D. & C. N. Andrews Co. (Amberola only.)	OHIO Cincinnati—The Phonograph Co. Cleveland—The Phonograph Co.	OREGON Portland—Edison Phonographs, Ltd.	PENNSYLVANIA Philadelphia—Girard Phonograph Co. Pittsburgh—Buehn Phonograph Co. Williamsport—W. A. Myers.	RHODE ISLAND Providence—J. A. Foster Co. (Amberola only.)	TEXAS Dallas—Texas-Oklahoma Phonograph Co.	UTAH Ogden—Proudfit Sporting Goods Co.	VIRGINIA Richmond—The C. B. Haynes Co., Inc.	WISCONSIN Milwaukee—The Phonograph Co. of Milwaukee.	CANADA Montreal—R. S. Williams & Sons Co., Ltd. St. John—W. H. Thorne & Co., Ltd. Toronto—R. S. Williams & Sons Co., Ltd. Vancouver—Kent Piano Co., Ltd. Winnipeg—R. S. Williams & Sons Co., Ltd. Calgary—R. S. Williams & Sons Co., Ltd.
---	---	---	--	---	--	---	---------------------------------------	---	---	--	--	--	---	---	--	--	--	--	--

The TALKING MACHINE WORLD

For the
makers &
sellers of
talking
machines

Published Each Month by Edward Lyman Bill, Inc., at 373 Fourth Ave., New York, November 15, 1918

*The instrument by which
the value of all musical
instruments is measured*

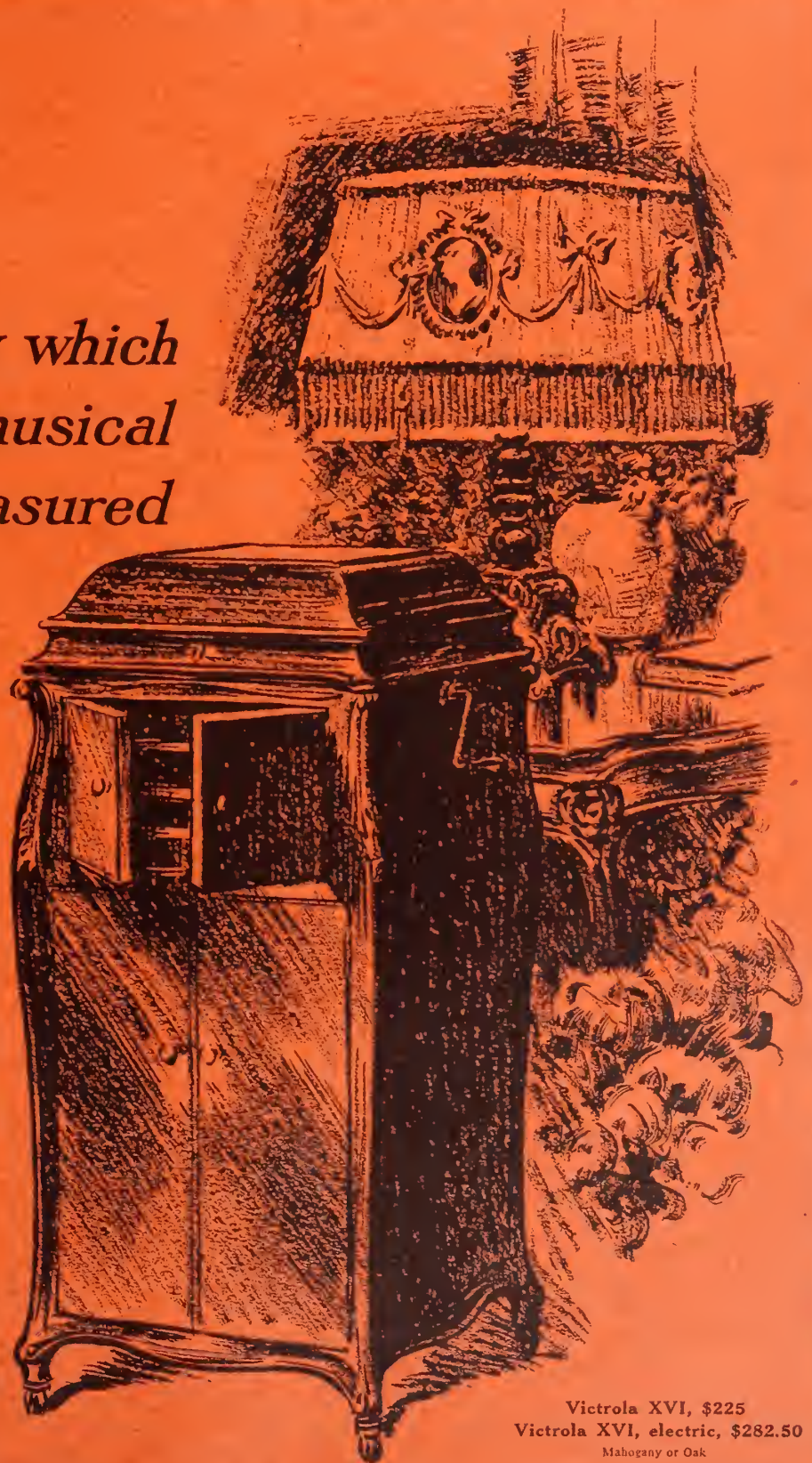

Victrola XVI, \$225
Victrola XVI, electric, \$282.50
Mahogany or Oak

Of Interest to the Entire Phonograph Trade

Sonora

Semi-Permanent, Silvered

Needles

IN line with the well known policy of Sonora to endorse and market only that which represents the highest standard of quality and efficiency, we are pleased to announce the perfection of a Semi-Permanent, Silvered Needle that possesses all the advantages possible with such a needle without carrying with it any disadvantages.

The points of superiority of these needles are sufficient to make their use permanent with every phonograph owner, and that of the Steel Needle, or other substitutes, forever undesirable.

The three strong outstanding advantages of this needle are:

Saves constant changing.

Plays from 50 to 100 times before wearing out.

Adds to the life of the records, because the record engaging point does not enlarge as it wears, retaining the same diameter throughout.

DEALERS:

Make your Needle Sales count by selling the Sonora Semi-Permanent Silvered Needle. It runs into volume quickly. These needles are put up in packages of five, and are sold for 30c retail. Attractive advertising material will be sent with each initial shipment of needles.

Suitable matter descriptive of this needle has been prepared and will be sent on request.

Send in your order for a sample shipment.

Sonora Phonograph Sales Company

Incorporated

George E. Brightson, President
279 Broadway, New York

Canadian Office: Ryrie Building, Toronto

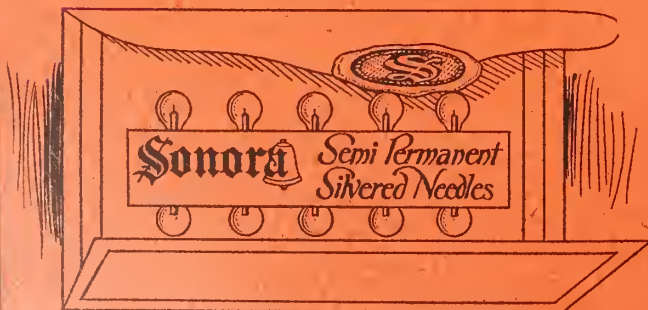

Package of five—30c

Three Grades—Loud, Medium, Soft

Sonora Semi-Permanent
Silvered Needle
After Being Used
Fifty Times

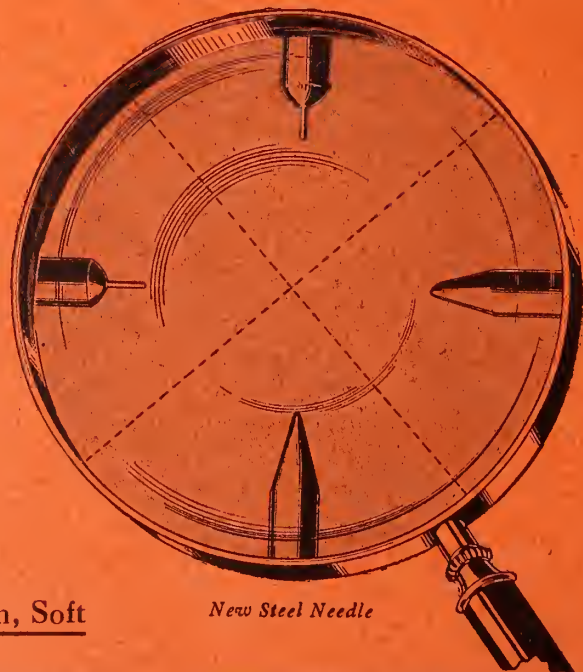

New Sonora
Semi-Permanent
Silvered
Needle

Ordinary
Steel
Needle
After
Being Used
Once
NOTE THE
BLUNT
POINT

New Steel Needle

The Talking Machine World

Vol. 14. No. 11

New York, November 15, 1918

Price Twenty-five Cents

AN INSPIRATION TO THE ARTISTS

Victor Trade-Mark Forms Basis for Two Clever and Pertinent Cartoons Which Are Founded on the Request of Germany for an Armistice

The famous Victor trade-mark rarely ever escapes the cartoonist when he wants ideas to suit great national occasions. "His Master's Voice" has been an inspiration to artists not only in this country, but throughout the world. It is so uniquely effective that it adapts itself most happily in expressing much in the hands

HE HEARS THE WILSON REPLY RECORD



A Timely Cartoon From the Montreal Star of those gifted men who discuss in a pictorial way the great questions of the day.

The recent correspondence between President Wilson and the German Government in regard to an armistice inspired the Montreal Daily Star of October 15 to put out the cartoon pictured herewith, unquestionably the very best of its kind that we have seen. Westerman, in the Ohio State Journal, also had a cartoon in that

HIS MASTER'S VOICE



Another Treatment in Ohio State Journal publication of October 21, which, while not so effective as that of his Canadian confrere, is also very pertinent.

Really, it is difficult to know what our cartoonists could do with the Victor trade-mark on great occasions.

WATCHING DEPRECIATION

Depreciation is an inevitable cost of doing business. It is felt that not until within the past decade have the grantors and receivers of credit appreciated the character and extent of this depreciation cost, but the careful student is beginning to realize that it is something which ought to be taken account of in all its angles by merchants.

INSTALL EDISON PHONOGRAPHS

G. L. Bell, manager of the phonograph department of the Kent Piano Co., Ltd., of Vancouver, B. C., advises The World that they have recently placed three new Edison phonographs on three of the steamships operated by the Canadian Pacific Railroad.

COLUMBIA SERVICE FLAG

Banner Displayed in Executive Office Has 534 Stars, With One Gold Star in Border

The Columbia Graphophone Co. are now displaying a service flag in their executive office in the Woolworth Building, New York, which tells the story that 534 of the great Columbia family have gone into the war and have been and are doing their mightiest to help Uncle Sam bring democracy and a "square deal" to those nations that have been transcending the rights of humanity and justice. In this service flag there is one gold star in the border, which signifies that one Columbia man has made the "supreme effort" and honored himself in so doing.

It may be interesting to remark that one of the stars of the 534 stands for President Francis H. Whitten, who is now in the U. S. Navy. The Columbia men represented in this service flag are serving in practically every line of activity on land and sea.

TAKES CHARGE IN BAYONNE

Samuel J. Smith, formerly connected with New York establishments, has been selected as the new manager of the Bayonne Talking Machine Co., Bayonne, N. J., succeeding the late Lewis Gurans, whose death caused such keen regret among a large army of friends and business associates. Mr. Smith intends to develop business for this house along progressive and efficient lines.

MAUD POWELL TELLS HOW THE FIGHTING MEN LOVE MUSIC

Recently Returned From Tour of Camps and Tells How the Soldiers Like the Best in Music—Sends Autographed Records to Boys at Front—Encourages This Move

Miss Maud Powell, the eminent American violinist, whose Victor records have won such wide acclaim, has been visiting the military camps of the country and is very enthusiastic over her reception, and the appreciation displayed by the soldiers for good music.

"We have been underestimating the taste, the enthusiasm, the spirit of our fighting men," declared Miss Powell as she turned from her desk to plunge wholeheartedly into a discussion of one of her favorite topics—the boys in the service. She was busy autographing talking machine records, adding to each carefully inscribed signature a little individual message, and on the last disc was written "Our hearts are with you." She might have said without egotism "my heart," for the major part of her time and practically her entire thought are given nowadays to the service of the American army.

"I wish you could see them as I have seen them," she went on, "crowding into Liberty theatres, sitting wedged together on hard benches, the men on the very ends sitting back to their neighbors to hold themselves on the narrow edge, some on the floor, others on the steps of the stage, sometimes squatting right at my feet as I play, and all of them intent to the last note: Forty minutes is what I usually plan for a program. But I rarely play less than an hour, and often it runs into an hour and forty minutes or even two hours. When men will listen that long to music which the managers scornfully call 'high brow,' under the most uncomfortable physical conditions, and beg for more and more and more when you try to stop, you may know they want more. They like the best. I play the same things I give at concerts—not long, too abstruse selections, but Bach, Beethoven, the classics of the violin. And the response! No audience is so rapt, none so completely mine. They know my repertoire and call for their favorites. I wish some of the men who have politely suggested that in my program we might insert 'something lively—a little vaude-

DISCONTINUE APPROVAL SYSTEM

Talking Machine Dealers in Louisville Place the Ban on the Sending Out of Machines and Records on Trial—Also Limit Deliveries

LOUISVILLE, KY., November 1.—The talking machine shops in Louisville at a conference held in the Hotel Henry Watterson last week contributed their mite to America's might in the nationwide movement to win the war. Leading dealers in phonographs and phonograph records attended the meeting and decided that, as an effort-saving measure, they would adhere strictly hereafter to the policy of not sending out talking machines and records on approval.

Only new machines and new records will figure in the business from now on. Further the dealers decided that beginning at once they will abide by the one-delivery-a-day plan that is being urged on merchants by the Government. These reforms in the business were made at the request of Eugene Straus, chairman of the Commercial Economy Division, Kentucky Council of National Defense. A dinner preceded the meeting at which the action was taken.

This policy of discontinuing the sending of records on approval is one that is being generally adopted throughout the country.

The concerns present that voted for the policies outlined were Herman Straus & Sons, Stewart Dry Goods Co., J. Bacon & Sons, Kaufman-Straus, Central Furniture Co., Adler Manufacturing Co., Schupp & Schmitt, Grafonola Co., and Trumbo Furniture Co.

ville act, for instance, could see the boys' faces and hear their applause. It would convince them, as it has me, that the men in service have as keen an appreciation of the best in music as any audience in the country."

Miss Powell pointed to the records before her in witness of her claim. Ever since America entered the war she has been donating talking machine records for which the boys have asked.

"By the way they ask for records, I know that their enthusiasm for good music is not feigned," Miss Powell went on. "It is one thing to applaud politely some one whom you know to have come miles over bad roads and on uncertain train schedules to play for you. It is quite another thing to request, as the talking machine record you want most to have, a violin solo of the 'high brow' type. That is why I say we have underestimated the taste of American soldiers by giving them low grade music, cheap popular stuff. For the appeal of a selection must be universal if it is to be played again and again to hundreds of men drawn from all walks of life, without growing stale or boresome. Yet you can see what they want: they have asked for these"—and she indicated the pile she had autographed, with their varying subjects of Sarasate, Beethoven and her own harmonizing of American negro melodies.

"I have stripped my own cabinet bare," went on Miss Powell, "not of 'slacker records,' as the Phonograph Record Recruiting Corps calls the idle ones most people have, but of the records I actually play and love myself. My favorites are all gone, and I can't deny there was a wrench in parting with them. Yet I believe that is the very contribution we each of us should make—the thing that we love so much ourselves that it hurts to part with it. In some way the sacrifice itself will make the contribution mean more to the boys—though they may not know the actual pull of the separation; somehow the gift that is given from the heart reaches best."

Increasing the Efficiency of Sales Force as a Means of Augmenting Sales

By W. E. Dewell

W. E. Dewell, manager of the Edison phonograph department of the Killian Co. Cedar Rapids, Ia., who handle the Edison exclusively, is a firm believer in the fact that salesmanship is the most important item in business, and holds that the successful salesman is one who makes a systematic study of his selling problems and seeks constantly to improve his methods and increase his efficiency.

"I have always maintained that the increase in sales comes from the increased efficiency of your sales people," says Mr. Dewell. "In other words the increase comes from within your store rather than from without. You can increase your volume of business very materially without an additional looker or prospect if your sales people are in the proper state of mind.

"The method used to accomplish this is shown herewith. Once every month I prepare such a bulletin, a copy to each sales person, and every morning one of the sales people calls our attention to the qualities listed so that every day in the year we are confronted with success qualities rather than thoughts that hamper our business and under this training some of my sales people have increased their sales from 60 to 80 per cent. Two of my young men in less than two years time have secured positions as department managers and are still using the success thoughts.

"Most sales people know the things that are listed on attached papers, but forget to use them, so that our monthly bulletins, with daily reference to them, keep those thoughts foremost in their minds."

A sample of Mr. Dewell's monthly bulletin reads as follows:

ANALYSIS OF PHONOGRAPH TO BE STUDIED AND USED

—QUESTIONS TO ASK OURSELVES AND BE ANSWERED

"(a) Who produced or manufactured it?"

"(b) What is the method of production?"

"(c) Where was it produced?"

"(d) Of what is it composed?"

"How does it compare as to finish, material, workmanship and price with competitive articles put out for the same purpose?"

"Can it be shown that its value to the purchaser compares favorably with its cost?"

"What is its purpose—in other words, what is it good for?"

"How can it be analyzed in such a way as to appeal by a logical process of argument to the

reason and best judgment of the customer?"

"What portions of it can be used to appeal to the emotional or spiritual nature of the customer?"

"To what class of people can it be sold? If it can be sold to several classes of people, is there a distinctive line of argument for each class?"

"We must study and apply analysis in order that we may be able to analyze all kinds of instruments, our competitors' as well as our own.

Eleven Positive Qualities to Practice for a Month

READ THEM EVERY DAY

- | | |
|-----------------|------------------|
| 1—Analysis | 6—Initiative |
| 2—Judgment | 7—Ambition |
| 3—System | 8—Enthusiasm |
| 4—Work | 9—Courtesy |
| 5—Concentration | 10—Agreeableness |
| | 11—Optimism |

What appears to be a small point of difference will often close the sale if the point is shown to be superior. Our ability then, to so analyze the instruments of all makes that our point of superiority, although it may be small, is clearly brought out, very often closes the sale.

"Everything else being equal, a customer prefers to buy from the Killian Company. Therefore, we must watch that everything is equal.

"People will not buy in a department that is dirty, or service poor, or sales people incompetent. They will not buy from a salesman who is poorly dressed, or discourteous, or a poor salesman, especially if he has a good competitor.

"We must thoroughly understand the construction of our instrument. We must learn to think the same thoughts which the man had who made it. If we can do that, if we can find out the reason for taking every step, we are getting a basic knowledge, which, after we have learned how to talk it, will fill our hearts with courage and confidence, and our mouth with words, which are not only the result of skill, but will

be skilfully put. It is a great thing to thoroughly understand every point in the talk or argument you are going to make, but it is a much greater art to be able to talk the ideas effectively.

"The salesman whose arguments are not strong, forceful, energetic, and backed up by a magnetic, healthful body, filled with pure red blood, and whose functions are not performed normally, is greatly handicapped.

"The greatest salesman is the one who is learning all the time, and thinking all the time, continually digging deeper into his subject for better ideas and better arguments.

"The cry of the hour is for a broader knowledge and more thoroughness.

"A man's personality does not come by accident. It is a natural gift, just as his mind and muscle are natural gifts, and like them it must be cultivated. Develop it by eliminating everything that is bad, and cultivating everything that is good.

"Cut out the blues as well as worry and jealousy and envy, and all their relatives. They are man's worst enemies. Fill your whole mind and lips with energy, hope, sunshine and an invincible determination to do things. Feel every minute of the day that it is the best day you ever had. Like thoughts are always attracted to each other. To think and feel enthusiasm, confidence and success, will develop in you a splendid personality, and set in motion the forces that will bring prosperity and power.

"Be in dead earnest, and your prize can be the world."

VICTOR DEALERS PLEDGE LOYALTY

The recent statement issued by the Victor Talking Machine Co., setting forth the present problems of the company in the matter of production, as well as giving an idea of the manner in which the Victor factory is being devoted in part to work for the Government, has brought pleasing response from dealers throughout the country. Hundreds of letters have been received at the Victor factory from dealers praising the company for putting its patriotism first, and expressing the intention of carrying on in the face of all difficulties until such time as the company can again meet in full the demands for its products.

LEGERDEMAIN and VICTOR SERVICE

D

ITSON

WE have no Magician's Bag of Tricks—
We Cannot Pull Machines and Records
Out of Empty Hats—But We Are Here to
Give the Victor Dealer the Best Service Pos-
sible and With the Spirit of Sincerity Always

Evident.

S

ERVICE

DITSON'S

The Wartime Service

BOSTON

VICTOR EXCLUSIVELY

NEW YORK

Victrola VI, \$32.50
Oak



Victrola IX, \$60
Mahogany or oak



Victrola XI, \$115
Mahogany or oak



Victrola XVI, \$225
Victrola XVI, electric, \$282.50
Mahogany or oak

**“Will there be a
Victrola in your home
this Christmas?”**

There's a lot in the power of sugges-
tion, and we're again using this phrase in
our advertising to suggest the Victrola for
Christmas.

We get the people thinking “Victrola”
and every Victor retailer benefits by it.

Victor Talking Machine Co.
Camden, N. J., U. S. A.

“Victrola” is the Registered Trade-mark of the Victor Talking Machine Company
designating the products of this Company only.

Warning: The use of the word Victrola upon or in the promotion or sale of
any other Talking Machine or Phonograph products is misleading and illegal.

Important Notice. Victor Records and Victor Machines are scientifically
co-ordinated and synchronized in the processes of manufacture, and their use,
one with the other, is absolutely essential to a perfect reproduction.



Victor Wholesalers

- Albany, N. Y....Gately-Haire Co., Inc.
- Atlanta, Ga.....Elyea-Austell Co.
Phillips & Crew Piano Co.
- Austin, Tex.....The Talking Machine Co., of
Texas.
- Baltimore, Md....Cohen & Hughes.
E. F. Droop & Sons Co.
H. R. Eisenbrandt Sons, Inc.
- Bangor, Me.....Andrews Music House Co.
- Birmingham, Ala.Talking Machine Co.
- Boston, Mass....Oliver Ditson Co.
The Eastern Talking Machine
Co.
- Brooklyn, N. Y...The M. Steinert & Sons Co.
- Butte, Mont.....Orton Bros.
- Chicago, Ill.....Lyon & Healy.
The Rudolph Wurlitzer Co.
Chicago Talking Machine Co.
- Cincinnati, O.....The Rudolph Wurlitzer Co.
- Cleveland, O.....The W. H. Buescher & Sons
Co.
The Collister & Sayle Co.
The Eclipse Musical Co.
- Columbus, O.....The Perry B. Whitsett Co.
- Dallas, Tex.....Sanger Bros.
- Denver, Colo.....The Hext Music Co.
The Knight-Campbell Music
Co.

- Des Moines, Ia....Mickel Bros. Co.
- Detroit, Mich.....Grinnell Bros.
- Elmira, N. Y.....Elmira Arms Co.
- El Paso, Tex.....W. G. Walz Co.
- Honolulu, T. H....Bergstrom Music Co., Ltd.
- Houston, Tex....Thos. Goggan & Bro.
- Indianapolis, Ind..Stewart Talking Machine Co.
- Jacksonville, Fla..Florida Talking Machine Co.
- Kansas City, Mo..J. W. Jenkins Sons Music Co.
Schmelzer Arms Co.
- Lincoln, Nebr....Ross P. Curtice Co.
- Little Rock, Ark..O. K. Houck Piano Co.
- Los Angeles, Cal..Sherman, Clay & Co.
- Memphis, Tenn....O. K. Houck Piano Co.
- Milwaukee, Wis...Badger Talking Machine Co.
- Minneapolis, Minn.Beckwith, O'Neill Co.
- Mobile, Ala.....Wm. H. Reynolds.
- Montreal, Can....Berliner Gramophone Co.,
Ltd.
- Nashville, Tenn....O. K. Houck Piano Co.
- Newark, N. J.....Price Talking Machine Co.
- New Haven, Conn.The Horton-Gallo-Creamer Co.
- New Orleans, La...Philip Werlein, Ltd.
- New York, N. Y....Blackman Talking Mach. Co.
Emanuel Blout.
C. Bruno & Son, Inc.
I. Davega, Jr., Inc.
S. B. Davega Co.
Charles H. Ditson & Co.
Lindsay Bros., Inc.
New York Talking Mach. Co.
Ormes, Inc.
Silas E. Pearsall Co.

- Omaha, Nebr.....A. Hospe Co.
Mickel Bros. Co.
- Peoria, Ill.....Putnam-Pace Co., Inc.
- Philadelphia, Pa..Louis Ruehn Co., Inc.
C. J. Henpe.
The George D. Ornstein Co.
Penn Phonograph Co., Inc.
The Talking Machine Co.
H. A. Weymann & Son, Inc.
- Pittsburgh, Pa....W. F. Frederick Piano Co.
C. C. Mellor Co., Ltd.
Standard Talking Machine Co.
- Portland, Me.....Cressey & Allen, Inc.
- Portland, Ors....Sherman, Clay & Co.
- Providence, R. I...J. Samuels & Bro., Inc.
- Richmond, Va....The Corley Co., Inc.
W. D. Moses & Co.
- Rochester, N. Y...E. J. Chapman.
The Talking Machine Co.
- Salt Lake City, U.Consolidated Music Co.
The John Elliott Clark Co.
- San Antonio, Tex.Thos. Goggan & Bros.
- San Francisco, Cal.Sherman, Clay & Co.
- Seattle, Wash.....Sherman, Clay & Co.
- Sioux Falls, S. D..Talking Machine Exchange.
- Spokane, Wash....Sherman, Clay & Co.
- St. Louis, Mo....Koerber-Brenner Music Co.
- St. Paul, Minn....W. J. Dyer & Bro.
- Syracuse, N. Y....W. D. Andrews Co.
- Toledo, O.....The Whitney & Currier Co.
- Washington, D. C.Cohen & Hughes.
E. F. Droop & Sons Co.
Robt. C. Rogers Co.

ALL RECORD CUSTOMERS ARE ALBUM CUSTOMERS



MAKING THEIR SELECTION

A Place for Every Record and Every Record in its Place

Albums are an **Indispensable Requisite** in the talking machine business and wherever records are sold. Practical and handy. Save time and records. A **profitable adjunct** to the business.

We manufacture disc Record Albums to fit cabinets of all sizes and styles. With the indexes they are a complete system for filing all disc records.

We have unexcelled manufacturing facilities, and considering quality our prices are the lowest. Write us, giving quantity you may desire, and we will quote prices.

OUR ALBUMS ARE MADE TO CONTAIN VICTOR, COLUMBIA, EDISON, PATHÉ AND ALL OTHER DISC RECORDS

NATIONAL PUBLISHING CO., 239 S. American St., PHILADELPHIA, PA.

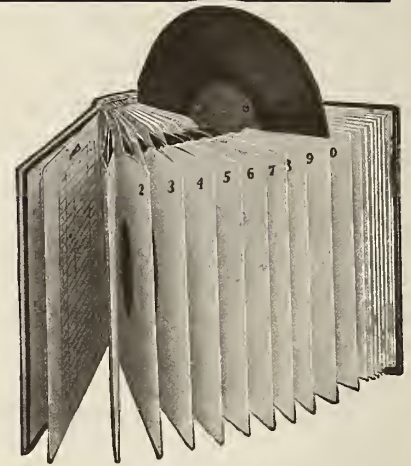

THE PERFECT PLAN

HOW TO CAPITALIZE THE CAPABILITIES OF THE SALESMAN

The Best Way to Attain This Result Is Not to Interfere with the Salesman's Policy of Handling Customers—Manager or Credit Man Should Not "Butt" In

We have all had the experience of seeing the manager of a store hover in the office as a salesman was handling a customer, and indicate by every action that he, the manager, was in a nervous sweat for fear that the salesman might not be able to handle the deal even though it consisted merely of taking a couple of clean collars out of a box and getting the thirty or forty cents therefor. We have also seen the manager deliberately butt into the transaction and simply kill the pleasing impression that was being made by the salesman. Under both situations it is not hard to imagine just what the salesman is thinking and how he feels. If his feelings and his thoughts were put into execution, the manager would probably be a pretty sick man.

For the manager to butt in and assist the salesman gives the impression to even the most casual customer that the salesman is not competent and cannot be depended upon, probably an impression just opposite to that which the manager seeks to create. The time to train and coach salesmen is during the off-hours and not in the presence of customers. On this important subject "The Voice of the Victor" for October had the following comments to make: "When a salesman is really successful in his work he is so by virtue of his own personality and his own methods. Why then take the chance of spoiling sales by having a third party butt into the game?"

"Music has been called the language of the emotions, and while it has been called a variety of other things that definition will suffice for the present. In any case, we all know that the music-loving public is made up quite largely of people who are essentially sensitive—and therefore easily offended.

"It stands to reason that if the salesman has been able to bring the customer up to the closing point he must have been able to establish some sort of sympathetic understanding and consequently it would seem that to introduce the credit man or the manager at this point would be more likely to result in a discord rather than in added harmony.

"We humans are not built according to the same specifications by a long shot. A credit man by the very nature of his business has to be of the cold type and there's something of the hard-shell crab about managers—otherwise instead of managing their business their business would soon be managing them. Neither of them will usually possess the infectious enthusiasm that is so necessary to the salesman. Circumstances compel them to be judicial rather than ardent—and there you are!

"It would seem then that the way to capitalize the capabilities of the salesman for all they are worth would be to keep the credit man in the office—with the door shut.

"The salesman is already on friendly terms

TALKING MACHINE EXPORTS GROW

Exports, Including Records, for Seven Months Ending July 31, Totaled \$2,693,868

WASHINGTON, D. C., October 31.—In the summary of exports and imports of the commerce of the United States for the month of July, 1918 (the latest period for which it has been compiled), which has just been issued, the following figures on talking machines and records appear:

The dutiable imports of talking machines and parts during July, 1918, amounted in value to \$20,209, as compared with \$45,827 worth, which were imported during the same month of 1917. The seven months' total ending July, 1918, showed importations valued at \$216,162, as compared with \$318,071 worth of talking machines and parts imported during the same period of 1917.

Talking machines to the number of 3,257, valued at \$119,021, were exported in July, 1918, as compared with 7,247 talking machines, valued at \$170,751, sent abroad in the same period of 1917. The seven months' total showed that we exported 45,229 talking machines, valued at \$1,359,798, as against 47,163 talking machines, valued at \$1,196,637, in 1917, and 31,177 talking machines, valued at \$791,093, in 1916. The total

with the customer and when it comes to the question of terms, references and so on there is a reserve fund of friendliness on both sides of the fence sufficient to withstand many jolts.

"Having progressed that far we may be pretty sure that the salesman is much less likely to put questions the wrong way, and when it comes to the real facts concerning credit—well—people don't pick up a Victrola and walk off with it, and the salesman will have ample opportunity to talk things over himself with the credit man long before the instrument in question is actually delivered to the customer.

"Selling musical instruments to music-loving people is not at all the same thing as establishing credit at a bank. Do you suppose it would add anything to the audience's enjoyment of an opera if the management put the box office on the stage?"

"Personally, we think it would result in a considerable loss of appetite."

exports of records and supplies for July, 1918, were valued at \$267,671, as compared with \$127,580, in July, 1917. For the seven months ending July, 1918, records and accessories were exported, valued at \$1,334,070, as compared with \$1,074,368, in 1917, and \$604,948, in 1916.

BOOSTING THE EDISON IN OKLAHOMA

A recent "Booster Trip" was made by the Enid Commercial Club through neighboring towns of Oklahoma. The accompanying photo-



graph was taken at Marshall, Okla., and shows the four salesmen's cars of the H. W. Lee Music Co., exclusive Edison dealers of Enid, that accompanied the members of the Enid Commercial Club and assisted them in their propaganda work.

WHERE MUSIC IS BADLY NEEDED

The medical supply base at Port Newark Terminal, N. J., is a comparatively new army post and suffers from the deficiencies of newness. There is no Y. M. C. A., no community theatre—no nothing, not even a phonograph.

If you have a talking machine and records, "low or high brow," that you feel would be doing their bit better serving in the army, send them along to Private George Liesner, Medical Corps, Port Newark Terminal, N. J.



This Trade-Mark on a Record Album Stands for Quality

A complete line of albums—from the lowest-priced good album to the finest metal back album made.

Write for sample of our 3 grades

New York Album & Card Co., 23-25 Lispenard St., New York

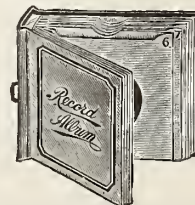

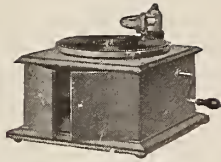

Victrola IV, \$22.50
Oak

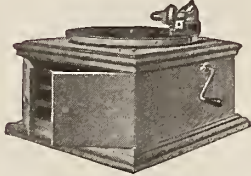

Victrola VI, \$32.50
Oak



Victrola VIII, \$50
Oak



Victrola IX, \$60
Mahogany or oak

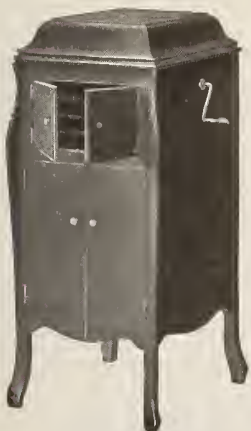

Victrola X, \$90
Mahogany or oak



Victrola XI, \$115
Mahogany or oak

“Will there be a Victrola in your home this Christmas?”

This important question will again confront the people of the whole country right on until Christmas.

It is the key-note of our nation-wide holiday advertising campaign, and its force will send thousands of customers into the stores of Victor retailers everywhere.



Victrola XIV, \$175
Mahogany or oak



Victrola XVI, \$225
Victrola XVI, electric, \$282.50
Mahogany or oak



Victrola XVII, \$275
Victrola XVII, electric, \$332.50
Mahogany or oak

Victor Talking Machine Co.

Camden, N. J., U. S. A.

“Victrola” is the Registered Trade-mark of the Victor Talking Machine Company designating the products of this Company only.

Warning: The use of the word Victrola upon or in the promotion or sale of any other Talking Machine or Phonograph products is misleading and illegal

Important Notice. Victor Records and Victor Machines are scientifically co-ordinated and synchronized in the processes of manufacture, and their use, one with the other, is absolutely essential to a perfect reproduction



“HIS MASTER'S VOICE”
REG. U.S. PAT. OFF.

The TALKING MACHINE WORLD

For the makers & sellers of talking machines

PUBLISHED BY EDWARD LYMAN BILL, Inc.

President and Treasurer, C. L. Bill, 373 Fourth Ave., New York; Vice-President, J. B. Spillane, 373 Fourth Ave., New York; Second Vice-President, J. Raymond Bill, 373 Fourth Ave., New York; Assistant Treasurer, Wm. A. Low.

J. B. SPILLANE, Editor

J. RAYMOND BILL, Associate Editor

Trade Representatives: B. BRITAIN WILSON, L. M. ROBINSON, WILSON D. BUSH, C. CHACE, V. D. WALSH, E. B. MUNCH, L. E. BOWERS, A. J. NICKLIN

Boston: JOHN H. WILSON, 324 Washington Street

Chicago Office: E. P. VAN HARLINGEN, Republic Building, 209 South State Street. Telephone, Wabash 5774

London, Eng., Office: 2 Gresham Buildings, Basinghall St. W. LIONEL STURDY, Mgr. The Talking Machine World has regular correspondents located in all of the principal cities throughout America.

Published the 15th of every month at 373 Fourth Ave., New York.

SUBSCRIPTION (including postage): United States, Mexico, \$2.00 per Year; Canada, \$2.25; all other countries, \$3.75. Single copies, 25 cents.

ADVERTISEMENTS: \$4.50 per inch, single column, per insertion. On quarterly or yearly contracts a special discount is allowed. Advertising pages, \$125.00.

REMITTANCES should be made payable to Edward Lyman Bill, Inc., by check or Post Office Money Order.

NOTICE TO ADVERTISERS.—Advertising copy should reach this office by the first of each month. By following this rule clients will greatly facilitate work at the publication headquarters.

Long Distance Telephones—Numbers 5982-5983 Madison Sq.
Cable Address: "Elbill," New York.

NEW YORK, NOVEMBER 15, 1918

EVEN in the midst of war and pestilence the talking machine trade refuses to be throttled. Proof of this statement is found in the fact that although during the past month the Spanish influenza epidemic has swept the country, practically paralyzing the industry in certain cities, to say nothing of crippling the sales staffs of the various stores, while the Liberty Loan took the patriotic away from their businesses and put them at the service of Uncle Sam, talking machine sales kept right on increasing. From every section of the country comes the same report, the volume of business being limited only by available stock. Some houses actually showed a percentage of increase during October, as compared with the same month of the previous year—this could hardly be believed were the figures not offered in support of the claims.

Each year the wiseacres declare, and have declared, that the peak of the talking machine business has been reached; that the trade will get into the normal rut just as other industries. Even though we have a first-class war on our hands business totals keep growing, and the end is not yet.

THE report of the action taken by the War Industries Board in the matter of supplies of various sorts for the talking machine manufacturing trade, as presented by the War Service Committee of the talking machine industry, should serve to set at rest the fears of many of those in the trade that their business will be irreparably crippled by the Federal orders.

There has, of course, been a curtailment ordered—curtailment that on the face of it seems rather heavy, but which under actual conditions should not prove a burden too heavy for the trade to bear. And it must be remembered that the announced regulations are effective only until January 1, after which time a readjustment will take place, based upon the progress of the war, and other matters of national and economic importance.

The trouble has been that there have been too many rumors, too much careless handling of facts, or alleged facts. Daily newspapers have seized upon any item from Washington referring to the regulation of talking machine output, and given it unwelcome prominence. These rumors and newspaper reports have naturally had their effect in disturbing men in the industry who did not know which way to turn. With the facts before them, however, they know just where they stand and can govern themselves accordingly.

With war turning so strongly in favor of the Allies, it is to be hoped that the expected victory and the peace that will come with it may be realized shortly. It may be some months in the future, but the crisis is passed. That much we know. Members of the talking machine trade must take courage and make every endeavor to "carry on" as strongly as possible during the emergency in order to be able to take advantage of the return to normal conditions.

Members of the trade must realize that as they are feeling the effects of the war and the demands it makes upon the country's resources, so is every other non-war industry. In fact, in many particulars the talking machine trade, due in no small measure to the efforts of those representing it at Washington, is in better shape than many other industries, so far as percentage of curtailment and percentage of supplies available go.

MUCH has been said and written of the necessity of shortening retail credits on talking machines by insisting upon larger down payments, as well as larger monthly instalments, in order to enable the dealer to keep a proper cash balance, to keep his books clean, and thereby be better able to meet the financial requirements of his business.

Quite as important as securing proper terms, however, is the question of collections. Every payment that is skipped means a fair percentage of loss to the dealer, and he should, therefore, see to it that no payments are skipped, that the money comes when it is due, or if not, that suitable action is taken.

This collection question applies particularly to accounts that have been running for a considerable time, and for one reason or another have become rather dormant. There are thousands of machines out on instalments at terms that, if made now, would spell ruination for the dealer. Each day such machines are out their value increases, and yet the old terms remain the same. It is only by wiping out such accounts, either by going strong on the collection end or by repossessing in cases where collections are impossible, that the dealer can expect to break even on the deal.

Cash is the biggest asset any merchant can have these days. The ability to discount his bills means that if there is any preference to be shown in the matter of stock allotment he is going to get it. It means that he will be able to meet without delay the tax bills from the Government, and the dozen and one other expenses that have cropped up during the war. It means that he has money upon which he can draw interest instead of having that money tied up in slow-paying accounts, where the interest is of a negligible quantity.

Keep the accounts paid up, or take the instrument back. This is not the time for hesitating or for tolerating the practices that in ordinary times might be winked at because competition was strong. Every machine out on instalments means one less on the floor to sell, and if it is not being paid for promptly, it is eating into the profits of the business.

Talking machine dealers—many of them—have solved the collection problem by selling machines only for cash. They find that they can get rid of all available stock on this basis, and at the same time leave the worries of the instalment accounts to the other fellow.

THE recent drive of the organization known as the Phonograph Records Recruiting Corps to gather all unused, or what are termed "slacker" records, for distribution among soldiers and sailors in camps, hospitals and ships, brought forth excellent results despite the fact that for months past various organizations in the different sections of the country, including the Red Cross and Y. M. C. A., have been soliciting records along similar lines.

The interesting fact is that the drive for "slacker" records has led to a realization that there is a genuine opportunity for providing new records for the fighting men, for it has been found that many people were inclined to turn over only records for which they had absolutely no use—records of popular songs of months or years ago, or records of songs of '61 or thereabouts, that have absolutely little appeal to the average soldier who, but a few months ago, was in civil life and in close touch with music of the day.

Even in the army these soldiers, through the medium of entertainments and through the playing of their bands, have

kept in touch with the new things in popular music, and naturally do not feel kindly toward records that are passé. As was stated in *The World* recently, the Government does not give the fighting men second-hand food or clothing, so why should they be expected to be satisfied with second-hand music?

We are glad to learn that the Phonograph Records Recruiting Corps have a campaign now on foot, in which prominent members of the trade have interested themselves, that has for its object the supplying of new records to the soldiers and sailors. The plan is to be worked through the dealers in every section of the country, who, while engaged in the patriotic work of supplying new records to men in the service, likewise find themselves in the way of making some legitimate profit in the transaction.

Many relatives and friends of soldiers, whether or not they, themselves, own machines, would be only too glad to purchase the latest records to be sent to their friends in the service, if the matter was brought to their attention in the proper manner. The new campaign has for its object the focusing of public attention on this question of supplying up-to-date music to our fighting men, and it should, without question, meet with the success it deserves.

AS *The World* goes to press, the new War Revenue bill is still in process of discussion, but not far enough advanced to permit of any satisfactory guess as to when it will be finally moulded into acceptable shape, passed and signed.

The Senate Finance Committee some time ago reached Section 900 of the bill, covering excise taxes on musical instruments, and decided to retain the 10 per cent. tax on talking machines, music boxes, hand organs and piano player mechanisms, reducing the tax from 10 per cent. to 5 per cent. on pianos and organs, other than pipe or hand organs, and entirely freeing church organs. Even after passing from the hands of the Senate Finance Committee this section of the bill, as well as the other sections, may be considered as being only in tentative form, and some sections may be entirely rewritten before the bill actually becomes a law.

The fight now being waged is directed against the floor tax provision of the law, which in the case of talking machines would mean that the dealer will be called upon to bear a tax of 10 per cent. on every instrument on record in his store at the time the law went into effect. The floor tax clause has been denounced as a most iniquitous piece of legislation, and if passed very likely will prove a burden to many dealers who, while holding sizable stocks, cannot realize the cash necessary to pay the floor tax demanded.

Meanwhile, the War Revenue bill will still bear close watching, for the trade can only be certain of its provisions when it finally leaves the President's hands. Up to that time there may

be changes that will add still further to the burdens of the industry. It is only by keeping in close touch with the situation in Washington that contemplated changes can be protested against and perhaps forestalled. Dealers everywhere should not fail to write their Senators and allow them to know how they feel on this important question.

CERTAINLY the music interests of the country, with which the talking machine trade was prominently identified, made a record that will stand out prominently in trade history in connection with the securing of subscriptions for the Fourth Liberty Loan. In the New York district alone Allied Music rounded up a total of over six and a half million dollars for the Loan, to say nothing of more than one million dollars raised in the Chicago trade, and substantial sums in every city of importance throughout the country.

Were the subscriptions to the Loan made by the music interests or made through their direct efforts brought together in one total, there is no question but that the figure would prove astounding not only to those who have been engaged in the work, but to the laymen who unfortunately frequently underrate the importance of music. It has happened, however, that only in a few districts were the music interests directly organized in support of the Loan, and in other sections of the country it is impossible to separate the subscriptions by and through musical circles from the general total. However, music both in the trade and profession has more than done its share. It has again proven conclusively its importance and its essentiality not alone in preserving the morale of the nation, but in tendering material financial support to the Government in its war program.

Although suffering severe financial loss through necessary curtailment of output, for instance, the members of the talking machine trade dug deep and often into their financial resources for the purchase of Liberty Bonds, and in a great many instances taxed their financial credit in support of the Loan. Surely the patriotism of the trade and profession has never been more clearly demonstrated.

Not only did the talking machine trade, every division of it, buy bonds till it hurt, but it was due largely to the generosity of the recording artists that the great rally at Carnegie Hall on September 30, which opened the drive, proved such an unqualified success and brought in almost enough subscriptions to cover the allied music quota in the New York district, set at \$4,350,000. At the final luncheon of the committee at the Hotel McAlpin, where nearly one and three-quarter million dollars was subscribed by those at the tables, the talking machine artists furnished the entertainment.

There is no question but that this trade did its full duty and a little bit more in making the greatest Loan in the history of nations a success.



Beans !!

Right now we're all in the trenches!

We want more goods and plenty of turkey. Necessity compels us to sell what we can get—and eat beans. But beans are rich in protein and life-sustaining.

Thanksgiving finds us all better off than last year and in 1919 we hope you and the Pearsall Kid will get the wish—plenty of turkey.

In the meantime, Pearsall Service is on a war-time schedule and doing everything in its power to serve you.

Silas E. Pearsall Co.

Wholesale Distributors of Victrolas and Records

10 East 39th Street

NEW YORK

To Purchasers of Brilliantone Steel Needles

CAUTION



**MADE IN
U.S.A.**

**MADE BY
AMERICANS**

YOU CAN

*get a sufficient quantity of Brilliantone Steel Needles
to take care of your increased holiday requirements*

IF YOU WILL ANTICIPATE

We are prepared to fill a reasonable number of orders promptly. We don't know how long our supply will last, or how soon we will have to call a halt on additional business.

THEREFORE — *If you want to be sure of an adequate supply of Brilliantone ALL-QUALITY Steel Needles, we say, ORDER TO-DAY.*

BRILLIANTONE STEEL NEEDLE CO. OF AMERICA
INCORPORATED

Suite 655-657-659 Marbridge Building, Broadway, at 34th Street

B. R. FORSTER,
President

**NEW YORK
CITY**



The Customer:

"Have you a record by So and So?" Perhaps you aren't sure. A glance at the *New Artists' Section* of the *New Catalog* tells you. Helpful.

**Columbia Graphophone Co.
NEW YORK**



NEW PATHE "ACTUELL" PRESENTS REVOLUTIONARY IDEA

Special Diaphragm, Embodying New Principle, Reproduces the Tones From the Record in Full Volume Without the Aid of Sound Box, Tone Arm or Amplifying Horn

In the Pathé "Actuell," officially announced by the Pathé Frères Phonograph Co. to a dozen or so invited guests at a luncheon at the company's factory in Brooklyn on October 28, there is found a phonograph of a distinctly revolutionary type without sound box or tone arm and entirely devoid of any form of amplifying horn. In other words, it represents a distinct new form of phonograph reproduction, representing years of experimenting and long and careful work of the Pathé experts in its final development to a point of practicability.

The fact that this new type of phonograph is now ready for presentation to the trade means that not only have the Pathé experts worked out to perfection a new process of reproducing, but they have been compelled to design an entirely new form of cabinet to hold it. The cabinet with the reproducing mechanism shown is illustrated herewith.

The "Actuell" consists principally of a large cone-shaped diaphragm of parchment fitted into a large circular aluminum frame. The center of the diaphragm is connected by a wire, under tension, with the needle holder. The sound as it comes from the record sets up vibrations in the wire, and the vibrations are released in the form of recognizable sound directly from the diaphragm. The volume of sound is controlled by a special attachment on the arm protecting the wire, for those who desire this method, but is more readily controlled by the opening and closing of the doors of the cabinet. There are two doors in front, each of which may be closed separately, and a large door on the side which also gives control to the tonal volume.

The circular frame holding the diaphragm is constructed of aluminum, heavily gold plated, as is the tube through which the wire runs from the needle to the diaphragm, as well as the other metal parts of the attachment. The simple twist of the needle holder permits the playing of either hill and dale or lateral cut records on the same machine, and it therefore makes the new reproducer practically universal in its application. It is claimed for the Pathé "Actuell" that, inasmuch as the sound comes in its full volume direct from the reproducer to the ear, it does not suffer from the overtones or conflicting vibrations that sometimes develop when the sound is carried through an amplifying current and likewise by reducing the number of factors incident to tone reproduction also reduces the chances of unsatisfactory reproduction.

At the official demonstration exhaustive tests were made of the new reproducer diaphragm on Pathé and other standard makes of machines, with a great variety of records, and it did not require an expert to testify as to the tone volume of the new reproducer or to the fact that through its use surface noise, if not entirely eliminated, is reduced to a point where it is not audible.

In introducing the "Actuell" E. A. Widmann, president of the Pathé Frères Phonograph Co., said that for over thirty years the inventive minds in the phonograph line have been experimenting to improve the small diaphragm now in general use and thereby improve tone reproduction. Innumerable experiments have also been

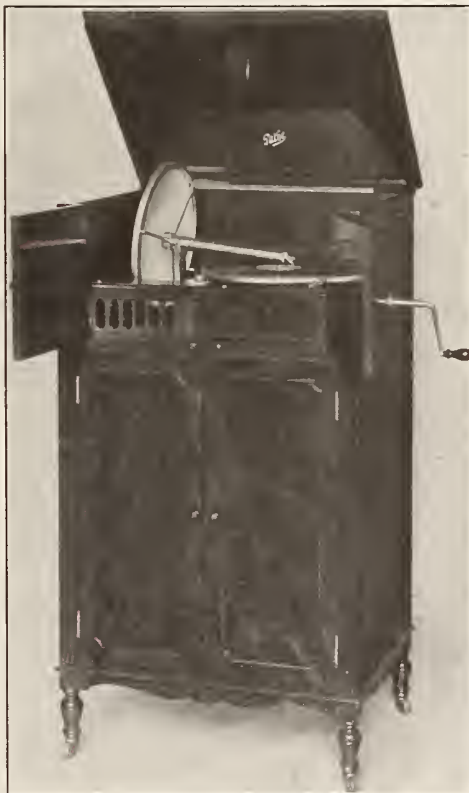

The New Pathé "Actuell"

made with various types of tone arms, horns, sound boxes, etc., and in some instances with apparent success. He stated that experiments had shown that a disc record made a number of years ago was in most respects, and particularly in the matter of tone quality, equal to the records made by the same manufacturers to-day,

indicating that improvements that have been made have been in the line of reproduction.

Through the use of the new device the tone, whether it be of the voice or a musical instrument, is thrown to every part of the room with equal intensity, and not thrown by the means of a horn in one particular direction.

"The object of this device," said Mr. Widmann, "is particularly directed to the attainment of direct propagation in free air from a record of self-sustaining sound waves, substantially corresponding to the original recorded sounds, in intensity or amplitude, as well as in pitch and timbre. The sound waves are amplified on the body of this device the same as the tone of a string is amplified on the body of a violin and faithfully transmits the vibrations of the record in a manner that the results are actual reproduction of the original voice or instrument, without change of character and without appreciable loss of energy."

For the present the phonographs embodying the new "Actuell" reproducing method will be confined to one style, similar to that illustrated. The elimination of the horn makes it possible to increase the width and decrease the depth of the cabinet, believed to be an attractive feature in the horn, and by increasing the width provides more room for the filing of records.

Those present at the luncheon, in addition to Mr. Widmann, included C. C. Conway, vice-president of the Hallet & Davis Piano Co., Boston; W. J. Craig, general manager and vice-president of the Pathé Frères Phonograph Co., Ltd., Canada; Frank L. Dyer, the well-known patent attorney, formerly actively connected with the phonograph trade; H. B. Ray, advertising manager of the company; Frank D. Lewis, chief engineer of the Pathé Co.; representatives of the trade press and others.

After an extended demonstration of the "Actuell," in which records of all types and a great variety of makes were given exhaustive comparative tests, several of the guests were taken on a tour of inspection through the big Pathé plant, observing with much interest the great activity prevailing therein.

The Coeola Phonograph & Cabinet Corp., of New York, was recently incorporated with a capital stock of \$10,000. Those interested are A. Posen, H. Rothstein and J. A. Kohn.



Style 900

THE REGINAPHONE

A phonograph of the highest grade with many exclusive features. The new Regina Sound-box is the greatest improvement in talking machines in years, reproducing all hill and dale and lateral cut records equally well, and in a manner unsurpassed.

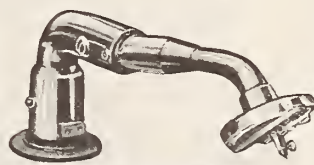

New Regina Sound-Box

Territory arrangements with active dealers. Send for particulars.

THE REGINA CO. 47 West 34th Street, NEW YORK
209 S. Wabash Ave., CHICAGO, ILL.

Manufacturers of the Regina Music Box and other musical instruments for over 25 years.

If You Do Not **SELL** Why Do You Not?

*There Are Many Reasons
Why You Should*



*If You Knew the Reasons
We Know You Would*



Some of the Reasons Why You Should



*The Reason
Of profit on their sale*

*The Reason
Of economy in their use*

*The Reason
Of their tonal qualities*

*The Reason
Of customers' satisfaction*

*The Reason
Of non-injury to
records*

*The Reason
Of increase in the
sale of records*



There Are Also Good Reasons Why You Should Sell The "B and H" Repointing Device

*The Reason
That there's a profit
in its sale.*

*The Reason
That it restores a
used needle to its
original condition.*

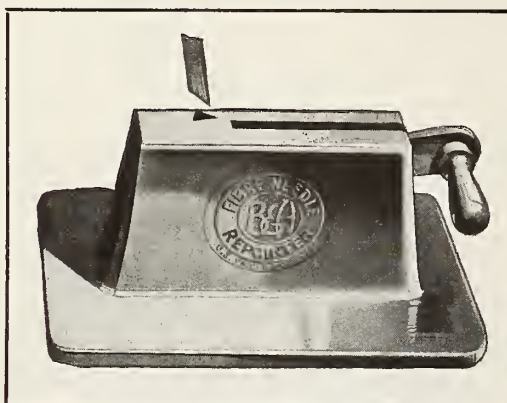

*The Reason
That each needle may
be repointed eight or
nine times.*

*The Reason
That each repointing
improves the tone.*

For the above and for
other good and suffi-
cient reasons, you

should write us at once
for further particulars
and prices.

U. S. PATENT DECEMBER 5, 1916
Retail Price, \$2.00

"B and H" FIBRE MANUFACTURING COMPANY

33-35 WEST KINZIE STREET

CHICAGO, ILL.

Customer Courtesy—Importance of its Meaning to Talking Machine Dealers :: By M. A. Morley

Gaining new and retaining old customers can be made a realization by the talking machine dealer who undertakes to solve this matter that at times becomes a problem by some simple rules. But simple as they are, they must be strictly adhered to in order to attain the ends desired. A disregard for some of the fundamentals often becomes a costly error to the man of business, and while perhaps not aware of the reason for his losses, goes forward in a blind manner that only makes his future success more difficult of attainment.

There are several qualifications that are demanded for success. Primary among these courtesy is to be considered, for the business man who is courteous has many strong arguments that will help him to increase his sales. Many of us go to the store where we know that the reception will be pleasant and the conduct of the proprietor or the salesperson marked by that extra eagerness to please. We like this kind of treatment, and though we might be in the nature of a grouch ourselves, we still look for and admire the contrary in the man who seeks to sell us either machines or records.

Realizing this, how many dealers bring this to bear with all the force and power that is implied therein? What percentage of the dealers cultivate this attribute and put into practice the little helps that will be found so much a force in its greater development? The little things count—the seeming trivial items in the day's labors that do so much to bring the sum total of the efforts that will increase our power in the community in which we live and barter and sell.

Greeting the customer with a smile, a word of cheer and an eagerness to prove yourself of service, at once arouses in the mind of the prospect a feeling of interest. He feels that you have a personal desire to see that his wants are well cared for, and that if it is possible to meet his desires this will be done. You may not be able to supply these requests, but at least your manner will imply that you are willing to do so, and this makes up for something that you may not have in stock. In case you do not have in stock the machine or record requested you can offer him something else. You have a record, for instance, that will please him, and there should be no trouble in making this evident quickly. If your actions are indifferent he will leave your store with a feeling that you are too independent to be courteous.

In addition to being courteous there are also the items of quality in the character of the machines and records offered and the service you render your customers. There is a sign that is in one store in a large city that reads, "Our Motto: Quality, Courtesy, Service." The term courtesy is practised here and its value is noted in a way that is good to see. A polite greeting, attention and a pleasant "thank you" do much to round out a purchase, and you leave a store of this kind with a feeling that the proprietors and salespeople really wish to have you call again.

Strictly speaking, customer courtesy includes quality and service, for you are there to please and how can this be possible if your stock is not the best and the kind of service you render only of the indifferent type? So the three are co-existent, and each has a part to play in the sum total that the dealer has to keep well in mind. If he overlooks any of these he will find that the neglect has been the cause of lost sales that cannot be readily made up. They are vital to his real success, and if he does not believe this is a fact let him give the matter a serious test and watch the results. The indifferent dealer is that man who soon finds out that his neglect has been costly. The public has been educated to-day to look for a great deal of consideration, and the wise dealer is the man who is going to see that this phase of his

business is given a fair and satisfactory trial.

Why not make this matter the leading idea in the conduct of your business? Perhaps you have done so in the past. If this is the case has it not been proven a profitable plan? But even if you have endeavored to do so is there still possible an idea that can be added to the list, an effort made that will prove to be a greater help? What rules have you made for the salespeople that cover this plan, and how well have they been trained in this important part of the business-getting system? If you

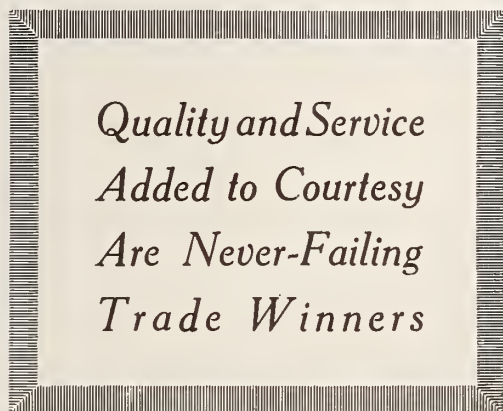

leave it to them they might not fully grasp its real value. Of course, you will try to see that all your customers are given a fair deal, and to do this demands that you resort to the most careful plans.

Some of your employes might be courteous at times, and then at another forget this unless you have been more than careful in making your rules strict. The fact that it costs nothing to be polite makes the labor one that is doubly profitable. It pays even a larger profit, for the pleased customer becomes the living advertisement for your store, and this is the kind that brings the quickest and largest returns. Others may fail at times, but the pleased customer is eager to say a good word for you, and you cannot afford to make even one enemy customer in all the trade that lies within your territory.

Every live talking machine dealer, however, fully understands the magnitude of having a

first-class stock of instruments and records to offer his trade. He understands, too, the value of making his stock display attractive. He notes the importance of making his store of such appeal by its character that it will naturally draw good customers. He combines these attributes with those of quality, service and courtesy, and then goes forward in a sea that is not beset with reefs and shoals that will wreck his industrial ship.

He is determined to make every man or woman or child (and the latter of to-day is the customer of to-morrow) welcome to his place of business. He is going to prove to them that he is there for service, and that he is not going to permit anything or anyone to stand in his way to prove his right to a hearing in the court of customer opinion and good will. Now this is going to take a great deal of care, and it is going to demand of him and his employes, everyone of them, a larger share of that extra attention to the little details that might have heretofore escaped him. Very often these little items that are passed by with a wave of the hand, and which are looked upon as of no material importance, are vital. It might be that the dealer has been neglectful of these, feeling that they were only trivial affairs that would be overlooked by the trade. So they are at times, but the repetition makes them increase in size, and in the eyes of the customer they become as mountains of neglect. They will not be tolerated for any length of time.

Give your customers every courteous consideration. Give them the best in service, in quality, in attention, in stock, in delivery, in fact, in every part of your undertaking, so that there will be no comebacks. The added cost, the increased labor and the time that you expend in bringing to perfection this larger measure of service, will be found an asset that is of the most significant value to you in making your name and success go hand in hand for greater achievements.

J. B. Scofield, formerly manager of the talking machine department of the Cable Piano Co., Toledo, O., is now fighting on the Italian front with the 332nd U. S. Infantry.

Important Announcement

Prices of Steel Needles

Have Advanced to 15c. a Package Retail

Owing to the continued scarcity of needles we have decided for the best interests of the trade to limit the shipments of no more than 50,000 to any one dealer.

MAGIC TONE NEEDLES, LOUD ONLY

70c. per 1000

Subject to change

The present offer is for your immediate acceptance.

I. DAVEGA, Jr., Inc.

VICTOR FACTORY DISTRIBUTORS

125 West 125th Street

NEW YORK

WORLD PHONOGRAPH CO.

MANUFACTURERS

The Instrument of Quality

The "World"

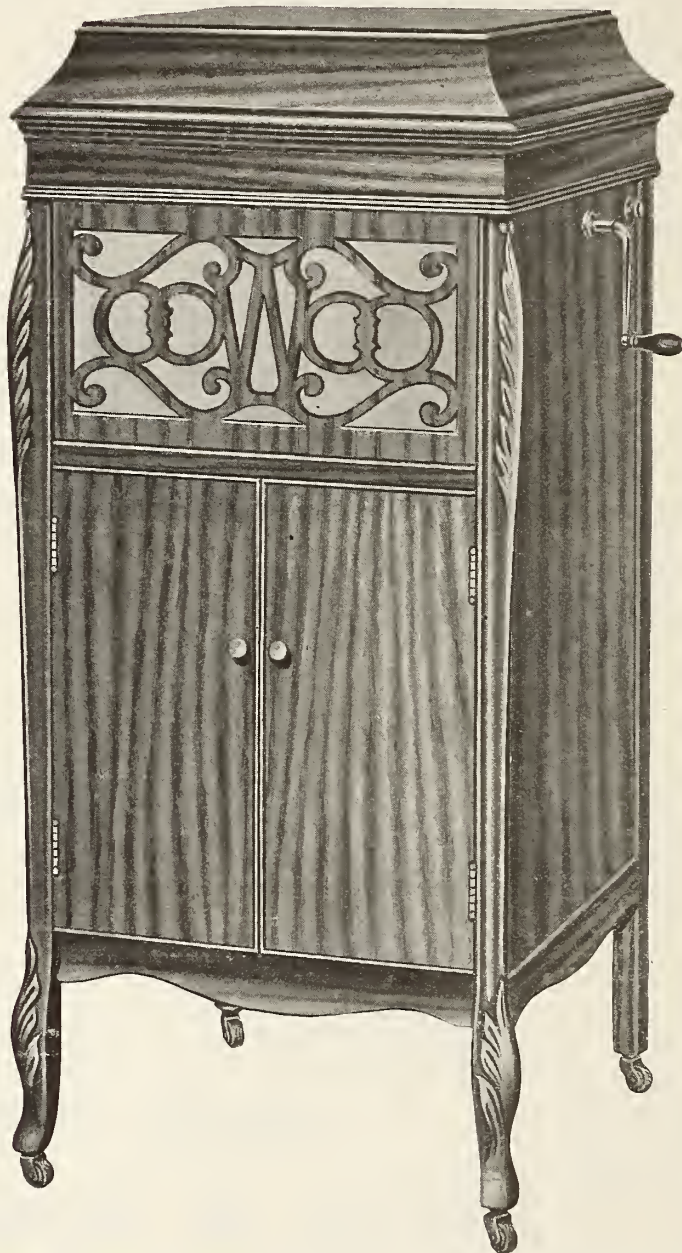

We can take
care of
immediate
wants

Send for
Catalogue

IT PLAYS ALL RECORDS

Every "World" Phonograph is built by master artisans in our own factory.

Correct design, high-grade construction, durability, appearance and finish are features of the "World" Phonograph.

Manufactured by

WORLD PHONOGRAPH CO.

GENERAL OFFICES AND FACTORY

736-738 TILDEN STREET

CHICAGO, ILL.

The Application of Period Decoration to Talking Machine Cabinets—The Hepplewhite

The talking machine designer of to-day who is giving attention to the reproduction of the English period styles will find much in the designs of Hepplewhite to gain for that style earnest consideration; for the designs of Hepplewhite, although in most every instance designed before 1788, may be used with perfect freedom to-day in adding embellishment to modern furniture.

Of all the famous cabinet makers of the eighteenth century, and they included Chippendale, Sheraton and the Adam brothers, none produced such a small number of impractical designs as Hepplewhite. Nearly every one of his designs shown in his book, "The Cabinet Maker and Upholsterer's Guide," published in 1788, can be used to-day just as it was originally created. Although formality was the rule of his time in the matter of household furniture, Hepplewhite managed to incorporate richness in his designs while still observing the general demands of the period. Of course, Hepplewhite's reputation rests most firmly upon his chairs, and in the chair he showed a distinct preference for the shield-back. However, he gave his attention

likewise to the designing of other furniture and managed to give to the various pieces a distinctiveness that has marked his work as un-

laid or painted by noted artists of the day. His furniture, as a rule, was made lighter than was that of Chippendale, and he depended for enriching his effects upon a generous use of pier glasses and mirrors. Hepplewhite was one of the few designers whose works can be observed today just as he designed them, for his book, "The Cabinet Maker and Upholsterer's Guide," published by A. Hepplewhite & Co. in 1788, is said to be found in the principal libraries and to be consulted at first hand.

The accompanying plate gives some general idea of the characteristic Hepplewhite designs as applied to various pieces of furniture.

Hepplewhite was partial to inlaid and painted designs and the inlay was always beautifully simple. His chairs and other furniture were in reality first covered with a coat of Japanese lacquer, and on this ground the delicate ornaments were painted. Gold on a black ground was a favorite combination, and the ornamentation for the most part inclined toward floral designs.

In adapting the motifs favored by Hepplewhite to talking machine cabinets of the present day, care must be used in preserving the general fitness of things. Ordinary cabinets cannot be turned into a Hepplewhite model by sticking on a few motifs at random any more than a Ford car can be turned into a Packard by changing the hubs. The design has to be either all Hepplewhite or not Hepplewhite, and the definite carrying out of the period idea must be planned with the designing of the cabinet in the beginning. For that matter the same rule holds good in the adaptation of any period design to cabinets.

Of the customers who buy cabinets in Hepplewhite design, nine out of ten will select a cabinet with some definite object in view and with some definite understanding as to what it represents. Even though the proportion of those who know were smaller, it would still be a matter of wisdom to cling to accuracy for the benefit of the sophisticated.

The new Victrola department of Geo. S. Dales, 120 Main street, Akron, O., was formally opened for public inspection the closing days of last month, and the arrangement and display of talking machines and records came in for much commendation.



Examples of Hepplewhite Designs

usual even to this day of great achievement. In his designs he favored ovals and curves of all descriptions. His table tops were in-



Reproducer

CERTAIN PATENTED FEATURES

found in PHON d' AMOUR exclusively make the PHON d' AMOUR a re-creation in the phonograph field.

The PHON d' AMOUR marks the first real departure in construction since phonographs were first offered to the public.

THE REPRODUCER IN PHON d' AMOUR

is an entirely new and greatly improved "sound box." It is finished throughout with the precision of a watch.

It is the patented features in PHON d' AMOUR that make the difference and which make this instrument the phonograph with the Soul of a Violin.



Copyright, 1917, by The Fritsch Phonograph Co. Trade Mark

THE FRITZSCH PHONOGRAPH COMPANY

228-230 West 7th Street

CINCINNATI, OHIO

Columbia Grafonola

The New Columbia Record Catalog

*An improved edition, with new sections;
new features; new ideas for the Columbia
Owner and the Columbia Dealer*



The Columbia Dealer may well be proud of the New Catalog! In binding, in style, in arrangement and in material it is far superior to any past issue. Not only has the typography been improved from the standpoint of readability, but the illustrations and the features have been greatly enlarged and improved. It is an interesting, informative book about phonograph music.

In the New Catalog are a number of innovations of real sales value to Columbia merchants. One of these is the method of making up the various sections—Part I. being a list of all artists making records for Columbia. Thus, when a customer asks, "Have you records by so and so?" you have the answer at your finger's tip.

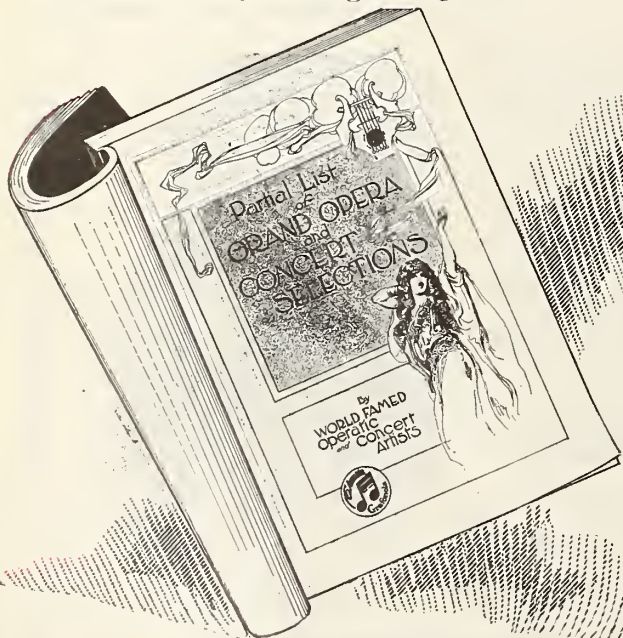
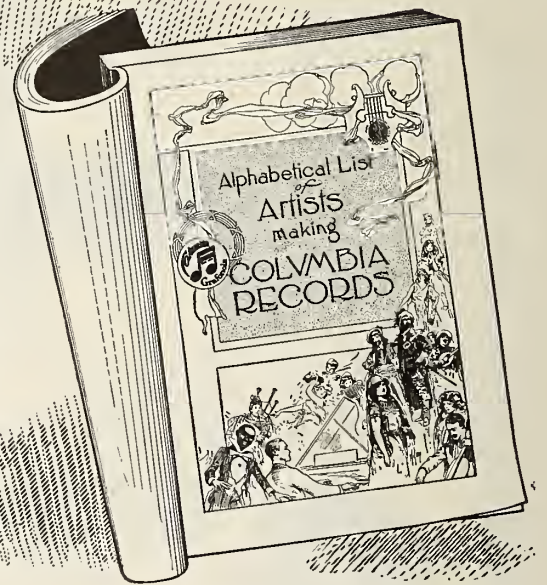

Part II., a complete alphabetical list of all Columbia Records, has been greatly improved by being broken up into familiar sub-heads.

*Your customers will want this New Catalog.
Make it an inducement for them to come to
your shop. That means business for YOU!*

COLUMBIA GRAPHOPHONE COMPANY NEW YORK



Sell Foreign Language Records, small investment—quick turnover—good profits.
International Record Dept.
102 West 38th Street New York

Columbia Grafonola

Make the New Catalog Make New Customers

*People like catalogs — particularly people
who own phonographs*

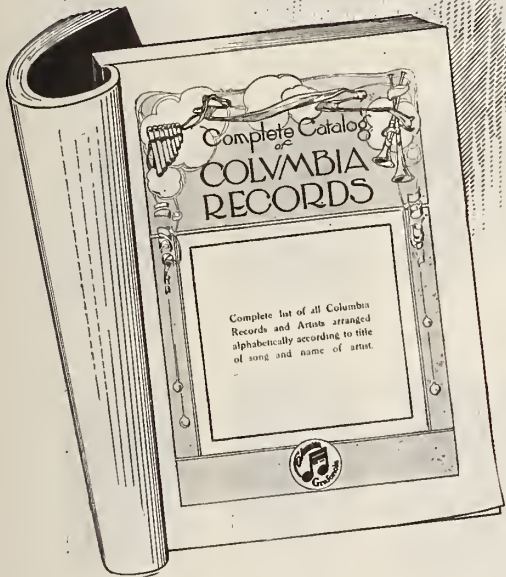
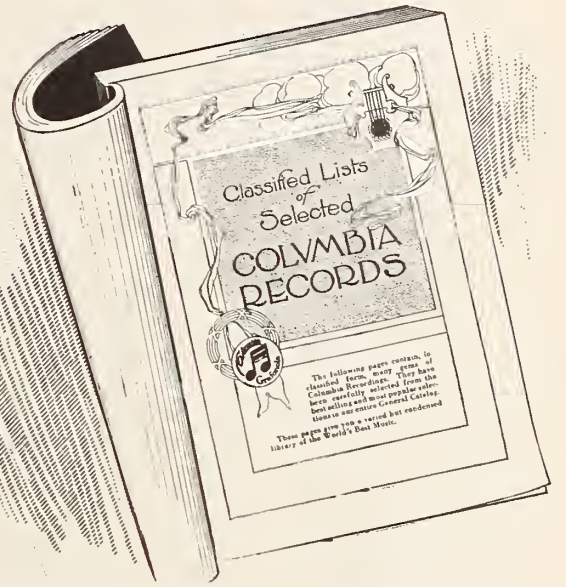

A record catalog is a source of inspiration to the music lover; a silent salesman in the home, working for the Columbia Dealer.

Put the new Columbia Catalog to work for you. Let your customers know you have it; send copies to your mailing list; display it in your windows — above all, study it and *know* what it contains.

The New Catalog is a decided improvement over any edition ever published before.

It will be a veritable encyclopædia of valuable information for the Columbia salesman, imparting a knowledge of the artists who make Columbia Records and of the records themselves that will inevitably result in increased selling capacity.

*Feature the New Catalog in your windows.
People who come in for it will often stop
to buy records.*

COLUMBIA GRAPHOPHONE COMPANY NEW YORK



Sell Foreign Language Records, small investment—quick turnover—good profits.
International Record Dept.
102 West 38th Street New York

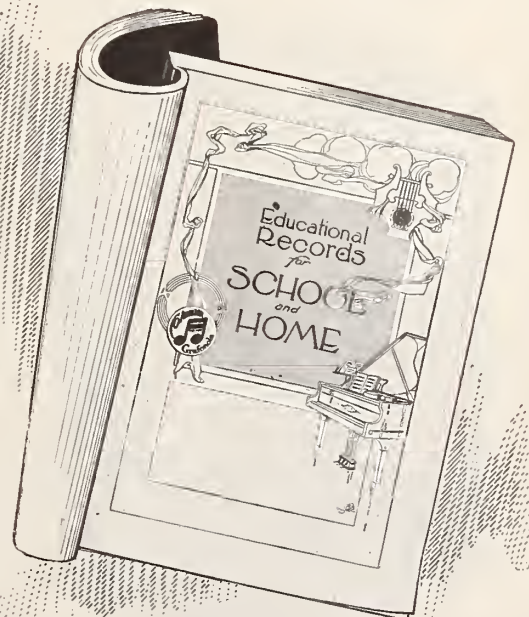

DON'T MAKE 'EM LIKE IT, GIVE 'EM WHAT THEY WANT

Play a Record for the Customer That He Knows and Likes and He'll Think You're a Great Judge of Good Music—Even the Preacher Man May Like a Little Jazz Occasionally

Sam Small as a matter of business—at least that was his alibi—took particular pains to spend several afternoons and evenings each week in the hall of the two-a-day, which is just plain vaudeville theatre, in the jazz joints on the main stem, or, if not there, listening more or less attentively to the music of some new operettas, or kidding himself that he was really getting full value for the price of a seat at the grand opera. After gathering that great variety of music into his soul, Sam just felt that he could count himself as an authority. He bulled himself into the belief that he knew it all, and the fact that he fell for his own dope proved that he was some little shoveler of the camouflage.

When some innocent prospect would wander into Sam's store for a demonstration of machines and records, he would just simply trot out a record of the latest music he heard, or next to the latest, if he did not have the latest in stock, and proceed to let it go. He didn't lose many sales, and any lack of enthusiasm on the part of the prospect was put down to ignorance, and winked at as such. The big blow-off came, however, when a big blonde dame with a purple feather in her yellow hat, and wearing number ten brogans, blew in and nodded her head in response to the inquiry as to whether she wanted to listen to how a machine played. Sam had heard an Irish tenor warble the night before and naturally slipped on the record of "Kathleen Mavourneen." The dame stood it nobly for about ten bars, and then blurted out, "That don't bane music ay lak. Ay guess ay go." Sam almost had to tie her to the chair until he could sail to the rack of Swede records and dig through the dust for something that would tickle the servant girl's heart. It was just Swede to him, but it was music to her.

Sam learned his lesson. His old slogan had been: "Make 'em like it. I know best." But, he tore up the past performance sheet, got him a new line of dope and changed the slogan to: "Find out what they want." He went into a trance and without the use of much second sight found out why an aged party had not gone into raptures over a selection from the latest "Folies." The old party hadn't seen the show and the music meant nothing to him, as Sam found out when he played over the records of another show that he, himself, had not seen.

The first rule in his little red book was then made to read: "Find out what shows they've seen and then shoot 'em the music. They'll like it because they know it." The second rule was: "Cut out the deaf and dumb signal system and get the prospect talking, and that talk will most likely give the low down on their nationality. Then give 'em the music from the old home town." "Gee," thought Sam. "If I had played Swede music for an Irishman, instead of Irish music for a Swede, what a beautiful funeral I'd have had." The third rule read: "When a sweet young thing cries for the record of a new popular song not in stock, don't just tell her you haven't got it. Tell her she will get tired of it anyhow in two weeks and sell her something for half a dollar more that will last longer.

"Even the preacher man doesn't want to hear hymns all the time. It is his business to listen to them in church, but when he is home and away from the flock, a little jazz doesn't go so rotten at that. Sell them what they like—what they understand," says Sam. "When a speaker tells an audience something they already know they think he is a wise guy. When he tells them something they don't know they generally think he is a liar. But don't make the mistake of playing them something they know too well. More than one murder has been committed because the wrong music was played at the wrong time. If you don't believe it, try playing the 'Wacht Am Rhine' in the open store for a pro-German without bolting the door and having the rear exit clear. When the mob breaks in there will be no time to waste in finding a new address."

C. H. RICHARDSON ENTERS SERVICE

Manager of Talking Machine Department of Clark Music Co., Syracuse, Joins U. S. A.

Charles H. Richardson, for some time manager of the talking machine department of the Clark Music Co., Syracuse, N. Y., has left to join the United States Tank Service. He is the tenth employe of the Clark Music Co. to enter the service, most of the men now being in France, and if he can fight like he can sell, look out Germany.

EDISON TONE TEST CAMPAIGN

Distinguished Artists Who Will Be Heard in 583 Recitals Which Have Been Booked by Edison Dealers for This Fall and Winter

In last month's World (page 97) details were given of the great Edison tone test campaign now under way, in which a total of 583 recitals have been booked by dealers for this fall. These, with the 1,742 previously given, make a total of 2,325 recitals which will have been given by the coming Christmas. This means that two million people will have heard demonstrations of the New Edison. The artists participating in this tour are pictured herewith.



HARDY WILLIAMSON
Tenor



MERLE ALCOCK
Contralto



MARIE RAPPOLD
Soprano



ALICE VERLET
Soprano



AMY ELLERMAN
Contralto



MARIE MORRISSEY
Contralto



MARIE TIFFANY
Soprano



IRMA SEYDEL
Violin



FLORENCE FERRELL
Soprano



BETSY LANE SHEPHERD
Soprano



GLEN ELLISON
Baritone



VERNON DALHART
Tenor



FLEMING TRIO



ODETTE LE FONTENAY
Soprano



IDA GARDNER
Contralto

PUSH PINS FROM OLD NEEDLES

All That is Needed Now is to Make Talking Machine Needles from Old Push Pins

One bright mind recently contributed to one of the popular magazines the description of a method for utilizing old talking machine needles in the making of push pins. According to the description, the needle is set, pointed upward in a small mould and sealing wax poured around the head of the needle, forming a button-like top. If another bright mind will come along and tell how to make good talking machine needles out of old push pins, he will be doing something that will prove of trade interest.

The Sampson Music Co., Boise, Idaho, recently purchased the entire stock of Columbia Grafonolas and records of the Kellerman Piano Co. The stock was moved to the Sampson Co. store.

Ward's Khaki Moving Covers



Grade "D," Cover with No. 3 Straps.

PROTECT YOUR MACHINES FROM ALL KINDS OF WEATHER

and will enable you to deliver them free from dust, scratches, bruises and all other finish destroyers

Our covers are faced with Standard Khaki, lined with a heavy grade flannel, interlined with an exceptionally good grade of heavy cotton or felt, diagonally and closely quilted, and manufactured according to the usual superior "WARD New London" quality.

Grade "D", medium size, \$6.00
Grade "D", large size, \$6.50
Grade "K", medium size, \$8.00
Grade "K", large size, \$9.00

Carrying Straps: No. 1 \$1.00; No. 2 \$2.00; No. 3 \$3.50

ORDER SAMPLE COVER ON APPROVAL

With Name of Machine silk embroidered on any Cover; extra, 30c.
With Dealer's Name and Address, first Cover; extra, \$1.15
Same on additional Covers, each extra, 60c.

Write for booklet

THE C. E. WARD CO.

(Well-known Lodge Regalia House)

101 William St., New London, Ohio

Also Manufacturers of Rubberized Covers and Dust Covers for the Wareroom

AEOLIAN-VOCALION PUBLICITY

ONE of the important factors in The Aeolian Company's success has been the character of its advertising. For many years this has been maintained at the highest level and has set the standard not only for advertisers in the music trade, but for practically all others using magazine and newspaper space.

Aeolian instruments are natural leaders in their various lines by right of intrinsic superiority. At the same time, Aeolian advertising has contributed essentially to the widespread and ready acceptance of this leadership.

Aeolian-Vocalion publicity is typically Aeolian. Strong, dignified and convincing, it is as far above the level of ordinary phonograph advertising as the Vocalion itself towers above ordinary phonographs.

Dealers who handle the Aeolian-Vocalion and new Vocalion Record, are aware of this. They are directly benefitted by the national publicity of the Vocalion and indirectly by the newspaper campaigns conducted in mediums with large spheres of influence outside

of their immediate environments. Likewise, the provision made by The Aeolian Company, whereby dealers may profit through participation in the national publicity is an added advantage to those who handle the Vocalion.

Reproductions of Vocalion and Vocalion Record advertisements appear on the three pages following. These reflect the general character of Vocalion publicity and are current at the moment.

The advertisement on the next page is a reproduction of one of the full pages *in color*, appearing monthly in the "Saturday Evening Post." Those following are newspaper advertisements being run in various large cities.

The unquestioned superiority of the Aeolian-Vocalion; its many advantages and selling features; the extraordinary character of the new Vocalion Record; the exceptional service rendered to dealers; and the unapproached quality of Vocalion publicity, make the representation of this instrument an invaluable asset to every progressive music merchant.

Catalog and complete information sent upon request

THE AEOLIAN COMPANY

AEOLIAN HALL, NEW YORK

A MASTERPIECE of REPRODUCTION

The New Vocalion Record—
Crimi's "On With the Play."

THIS wonderful aria from "Pagliacci" is far more than a mere song. In its beautiful melody the composer has sounded the depths of human emotion. The very notes themselves voice the anguish of the poor clown who, despite a breaking heart, must carry through his part to the end.

Giulio Crimi has outdone himself in making this record. One of the greatest tenors alive today, his talent and his art have found real inspiration in the magnificent results achieved by the Vocalion system of recording.

Those who hear Vocalion Records played upon the Aeolian-Vocalion, listen amazed to new musical effects from the phonograph. Full, rich and clear, the tones of the human voice come from the instrument with all the beauty and freshness of nature's endowment.

In perfecting this wonderful new system of recording—in making a record commensurate with the unrivalled musical character of the Vocalion—the Aeolian Company has put the musical world still further in its debt. One more notable feature of advantage it has also added to the sum of those already possessed by this instrument.

THE AEOLIAN-VOCALION is a product of the world's leading manufacturers of musical instruments. As a phonograph, it occupies the same position of distinguished leadership as this maker's other famous instruments.

The features of the Aeolian-Vocalion that give it pre-eminence, are first of all a musical quality that is unapproached. Second—a personal control of expression through its celebrated "Graduola" that no other phonograph possesses. Third—a beauty and distinctiveness of appearance that has set an entirely new standard. Fourth—a perfection of mechanical devices, such as its Automatic Stop, that bespeaks the unrivalled skill and experience of its makers. And, finally, the notable advantages it possesses in its Universal Tone-Arm, which permits the Vocalion to play *all makes* of records in addition to the exclusive privilege of playing the wonderful new Vocalion Records.



GIULIO CRIMI

THE AEOLIAN COMPANY announces the initial and exclusive voice recordings of Giulio Crimi, leading Italian tenor of the Chicago Opera Company. Signor Crimi has been the sensation of the past season with the Chicago organization. His magnificent voice has the irresistible charm and freshness of youth, to which is added a musicianly sense of artistic values capable of standing the test of comparison with other world-famous tenors.

The AEOLIAN VOCALION

Made by

The AEOLIAN COMPANY

LONDON *AEOLIAN HALL* PARIS
NEW YORK

VOCALION STYLE "I"

Illustrated, price \$225. Other conventional models, equipped with Graduola, are priced from \$115 upward; without Graduola, from \$50. Many beautiful. Period models, priced from \$240.

All prices subject to change.



ORCHESTRAL MUSIC

THE GRANDEUR AND
RICHNESS OF THE GREAT
INSTRUMENTAL CHORUS
VOICED WITH MOVING
REALISM
BY THE

AEOLIAN VOCALION

▼

TO put into the hands of music-lovers a phonograph so wonderfully constructed that it can actually reproduce the tonal sonority of the orchestra—its height and depth and breadth of voice—

To give them a phonograph on which every distinctive-voiced orchestral instrument is clearly recognizable—on which the wistful strings and pallid flutes, mellow clarinets and pealing brasses sing their parts with perfect and thrilling individualism—

And, above all, to put into their hands a conductor's baton—a wonderful new controlling device by which they may lead the orchestra—may color, shade and modify just as the orchestra conductor himself expresses his ideas in the talents of his assembled players.

This is the achievement of [the Aeolian Company in producing its extraordinary new phonograph—the Aeolian-Vocalion.

▼

“Truly the Aeolian-Vocalion is the climax of phonograph development. With distinctive beauty of exterior—with unapproached tonal richness and capacity and with its exclusive feature for personal expression control (the Graduola), the supremacy it has so quickly gained is but the measure of its manifold superiority.”

▼

THE AEOLIAN COMPANY
AEOLIAN HALL NEW YORK





Colin O'More

A great future awaits this splendid young tenor, whose voice of extraordinary beauty will be recorded exclusively on Vocalion Records. Following his recital at Aeolian Hall on Saturday, October 19th, Colin O'More is engaged for a recital tour which will cover the principal musical centers of America and will familiarize thousands of music lovers with the delightful charm of his artistry.



COLIN O'MORE

The Gifted Irish Tenor

Will Make Vocalion Records Exclusively

COLIN O'MORE possesses one of those rare voices that makes you glad or sad as the spirit of the song dictates. This talented young tenor adds new beauties of tone and interpretation to the old familiar ballads that everyone loves. His artistry is both finished and spontaneous.

Vocalion Records have reproduced Colin O'More's voice with remarkable fidelity. Through the *naturalness* of the new system of Vocalion recording, the individual quality of this unusual voice, rich in heart appeal, is brought to you with amazing realism.

The Vocalion Records of Colin O'More will be played for you at any time. You will find many favorites among the selections recorded.

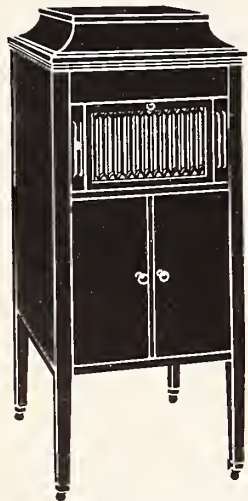

Style 500, Price \$175

Vocalion Records by Colin O'More	}	<i>At Dawning (Cadman)</i>	} 22007—10-inch—\$1.00
		<i>I Hear a Thrush at Eve (Cadman)</i>	
		<i>Bonnie Sweet Bessie (Gilbert)</i>	} 22002—10-inch—\$1.00
		<i>I Hear You Calling Me (Marshall)</i>	
		<i>Who Knows (Ball)</i>	} 22006—10-inch—\$1.00

THE AEOLIAN-VOCALION

As an unequalled medium for interpreting Vocalion and all other standard makes of records, the Aeolian-Vocalion, the world's most artistic phonograph, stands supreme.

The advantages of this wonderful instrument are manifold. Its clear beautiful tone has placed

it in an individual class, far removed from the ordinary phonograph.

By means of the Graduola, a musicianly and exclusive device, new beauties of expression-control are possible to the owners of the Aeolian-Vocalion.

Aeolian-Vocalions from \$50 upward Graduola Models from \$115
Distinctive Period Styles from \$240

THE AEOLIAN COMPANY

Makers of the famous Pianola Largest manufacturers of musical instruments in the world

In MANHATTAN
29 West 42d Street

In THE BRONX
367 E. 149th Street

In BROOKLYN
11 Flatbush Ave.

In NEWARK
895 Broad Street

INDIA SEEN FROM THE VIEWPOINT OF THE BUSINESS MAN

Why the United States Gets Only a Small Share of the Business of That Country—Present Conditions and What the Future Offers as the Result of Social Reforms—Many Interesting Facts

A most interesting visitor to New York just now is Valabhdas Runchordas, head of Valabhdas Runchordas & Co., Bombay, and sole proprietor of the Talking Machine & Indian Record Co., of Bombay, Calcutta and Madras. Mr. Runchordas is in the United States in the interests of his business as a general importer and at the same time to pay particular attention to the matter of securing talking machine and record supplies of various kinds. He has been active in the talking machine field in India for over twenty years, and states that before the war the great volume of business was done with machines and records of German make. The forced withdrawal of these products from the market has opened up a field for fresh importations with other countries.

Small American Business in India

Mr. Runchordas offered the interesting information that before the war only 7.3 of the total importations into India came from the United States, and, although European trade was almost entirely cut off by the war, especially trade with the Central Powers, in 1917 the importations from the United States were only 12.9, the greatest volume of imports, of course, being from Great Britain. When from the total volume of American export business handled in India is taken the great business of the Standard Oil Co., the Remington Typewriter Co. and the Singer Sewing Machine Co., it will be seen that there is not a very material business done in other American lines. The principal reason for the fact that American products do not figure more prominently in the Indian field, it is said, is that American manufacturers are inclined to be conservative in their methods, and put forth their efforts in endeavoring to force their standard styles and designs upon the native buyers rather than follow the example of European manufacturers and redesign their products to meet the wishes and requirements of the export trade. In more than one case this failure to meet the native demands even by making slight changes in styles has forced Indian importers to stop handling American products.

Low-Priced Records Have the Call

The reason for the large business enjoyed in German records in India before the war was due to the fact that they could be sold at a low price, approximately 40 cents for the double-sided records, and were offered in recordings of native dialects of which there are about 130, between thirty and forty having been recorded thus far. American cylinder records were sold to a considerable extent in India, while the cylinder records and machines were the vogue, but since the accession of the disc the trade has swung to Europe. When it comes to records of European or American music, especially vocal recordings, the Indian trade demands English records, as the English accent is more familiar to them.

Indian talking machine buyers appear to favor the horn machines, particularly those selling at low prices—\$6 to \$15 American money. To date American manufacturers have offered cabinet machines so popular in this country, but which command prices that prohibit their extended sale in India.

Japanese Invading Indian Field

Since the beginning of the war the Japanese have given much attention to the development of the talking machine trade in India, and are especially active in supplying machines in parts of the sort required in that country. The purchasing power of the majority of natives of India is very limited, particularly outside of the Bombay Presidency, and the large cities of the other provinces, and, although India as a whole has a population of over 350,000,000, three and one-half times that of the entire United States, the volume of business that can be handled is little, if any, larger than is taken care of under normal conditions in a city the size of San Francisco.

There are at present only something like 200,000 Europeans, mostly Englishmen, in India, and upon them the merchants must depend for the market for higher-priced talking machines and pianos. Moreover, a large proportion of the European population consists of clerks and under officials, whose financial condition does not permit them to indulge very extensively in luxuries and semi-luxuries. It is believed that if American manufacturers study the Indian field thoroughly and prepare to cater to the peculiar demands of that country in the matter of supplies and prices, they will have a good opportunity of participating in its expected commercial development.

There is at present in effect an import duty of 7½ per cent. based on trade prices of talking machines and records, and to this must be added rather heavy ocean freight rates.

The question of caste in India is a big one, the original four castes of some centuries ago having been divided and subdivided through various political and social disagreements until there are now existing something like over 3,000 distinct castes. Of these the members of the Bhattia caste are recognized as the leaders in the commercial life. The members of this caste, although centered in Bombay Presidency, are to be found in all of the various sections of India, and in recent years in other countries, particularly Japan, and are found to develop in business with greater rapidity and more success than others of their race.

Bright Prospects for Commercial Growth

Much of the slowness of India's commercial growth, it is declared, is directly traceable to the existence of the caste system. Up until a comparatively few years quite rigid caste regulations covering his method and mode of living made it practically impossible for the Bhattia to travel overseas and into foreign countries without running the risk of losing caste, considered a very grave punishment. There was started, however, a wave of social reform, with Mr. Runchordas as one of the active reformers. Many of the caste regulations were set aside, with the result that the Bhattia can now feel free to travel about at will, although still observing the chief laws of his caste.

It is expected that after the war these leaders among the Indian merchants will tend more and more to foreign travel with a view to get-

ting in personal contact with exporters in Europe and America, thus gaining at first hand an intimate knowledge of the markets. Under such conditions the development of Indian trade should be rapid and untrammelled. Numerous commercial organizations have been formed in India in the past, and particularly in the Bombay Presidency, with a view to promoting the industrial development of the country. Shortly before the war there was organized the Indian Commercial Congress, designed to promote both the domestic and foreign trade of India, but activities have practically ceased for the duration of the war.

Meanwhile, manufacturing in India has advanced at a rapid rate, a fact particularly true of the cotton industry, 1,318,810,126 yards of cotton goods having been manufactured in that country during the year 1916-1917. This industrial development is expected to enable India to prosper to a point where the country will provide a fertile field for foreign manufacturers.

Where United States Consuls Are Located

At the present time the United States has Consuls in Calcutta, Rangoon, Madras, Colombo, Bombay, Karachi and Adel, with Consular representatives in Bucrah and Chittagong. It is his belief in after-war development of Indian commerce that has moved Mr. Runchordas to make his present extended visit to the United States. It is his belief in India's commercial future that also prompted Mr. Runchordas to take an active interest as a director in the Shrikrishna Stores Co., Ltd., a chain of mercantile establishments conducted without profit for the purpose of providing a practical education in merchandising for Indian youths.

He plans to remain in New York and other Eastern cities for a month or six weeks before working his way back to the Pacific Coast.

Mr. Runchordas has been a subscriber to The Talking Machine World since its inception, and through it has become very familiar with the concerns and situation in the talking machine trade in this country. Incidentally he continued his World subscription, on a cash basis, for a number of years to come.

"INTERESTING AND VALUABLE"

The "Pathé Phono-Cinema-Chine" in a recent letter from Shanghai, China, enclosing a subscription for The World under date of September 13, writes enthusiastically about the merits of The Talking Machine World, the contents of which this institution has found most interesting and valuable.



It's a Pretty Good Idea to always keep in mind the fact that a

SCHUBERT PHONOGRAPH

will bear the closest inspection; its particular qualities warrant investigation, and hundreds of friends everywhere loudly extol its superiority.

SIX MODELS \$60.00 UP

SCHUBERT RECORDS

The BELL TALKING MACHINE CORPORATION

Offices and Show Rooms:
44 West 37th Street, New York

Factory:
85 Southern Boulevard, Bronx, New York

Export Department, 498-504 Broadway, New York, N. Y., E. U. A.
Smith-Woodward Piano Co., 1018 Capitol Ave., Houston, Tex., Local Distributor
Special Australian Representative, B. LESCHHAU, 350-2 Flinders Lane, Melbourne





Edison Message No. 31

Victory!

The music of the Allies—the music that sweeps over No Man's Land to the frightened and defeated hordes of Germany—now screams with the triumphant note of Victory.

The supreme moments of the war are approaching; and then the era of reconstruction and "Peace on earth, good will to men."

The patriotic enthusiasm of the people of America that is calling for "Unconditional Surrender" can be strengthened and enhanced by the rightly directed influence of music.

The Edison Dealer who believes in this "unnegotiated" settlement of the war and who rightly uses the musical influence he commands will help the cause of Victory—Victory on the fields of battle and Victory for himself in his own business.

THOMAS A. EDISON, Inc.

Orange, N. J.

Keeping Good Help Should Be a Prime Consideration With Live Dealers :: :: By Joseph A. Carroll

The shrewd, far-sighted merchant recognizes one all-important feature in the conduct of his business—the value of good help. But beyond simple recognition, he appreciates quality of service, and appreciating, he rewards it.

It can be accepted almost as an axiom that the superiority or inferiority of a dealer's help determines the success or failure of his store. Where there is strong competition it is practically certain.

The merchant who is abreast of the times, who is ambitious to build up a thriving trade, and is ever alert to the benefits derived from attracting the best class of customers to his store—those who buy frequently and buy in quantity and pay cash—realizes that this can be done only by devoting his thought and energy to improving his stock, its systematic arrangement, and its attractive display—but above all by giving excellent service, which means employing neat, courteous, intelligent and smart help.

It is not an easy matter to get exactly the high grade, willing worker one wishes, but it is always possible to develop to a higher point of efficiency the ability of the help one has at hand, if thought is given to the proposition.

Two Classes of Employers

One employer dominates his help too arbitrarily, and thus stifles their growth and lessens their worth. He is bent on impressing his own importance and his superiority of mind and knowledge. The other employer treats his employes with consideration; he invites suggestion, encourages initiative and arouses a lively and profitable interest in all his clerks in the success of his business. He makes of them an enthusiastic and productive part in the upbuild and expansion of his mercantile progress.

Few if any men or women fail to respond to fair treatment. They will do better, more earnest and more accurate work if their employer is less of a "boss" and more of a "human being" in his dealings with them. It is then greatly to the advantage of the employer to appeal to that side of a man's nature—and every man has such a side—which awakens in him good impulses; to draw from a man that which is best in him rather than by a harsh, overbearing and unsympathetic attitude force to the surface an indifferent, sullen and oftentimes antagonistic disposition toward an employer.

A Paying Investment

When you employ clerks you have an investment. Why not make it pay? How can you do this? Show by your interest in them that you regard them as an important factor in your business. Hold weekly meetings; discuss your merchandising problems with them; your plans for the next season; your future prospects. Be frank with them. Let them exchange ideas on policies; invite criticisms from them; show a broad, open mind and the results will amaze you. You'll receive a number of sound and valuable ideas. You'll put seriousness, ambition and enthusiastic interest where formerly existed, perhaps, frivolity, indifference and lukewarmness.

The clerk is human. He wants recognition quite as much as you and I, and once it is given he will be a better, more valuable clerk.

Developing Latent Ability

Don't despise your clerk simply because he is a clerk. He may not be one long. The clerk of to-day is the successful merchant of tomorrow. Husband the ability, cleverness and resources of your clerks. Make them an asset, not a liability. Stimulate them to think, to originate, to co-operate. The obscure fellow behind that remote counter may have the very idea that if told would solve your greatest difficulty. He's timid. He's afraid to speak. You've never inspired him to do so.

Don't belittle the office boy, the stenographer, or the man or girl behind the counter. Each has a brain; each can think. Teach them to do so. Urge them to develop.

The most dangerous man—be it the boss himself—in any outfit is the one who stifles the growth of subordinates. The most effective executive is he who takes the employes at hand and handles them in a way that will bring the

Good Help Invaluable If the Retail Merchant Has an Eye to the Future

most good out of each and rounds them all into the smoothest running, most animated and greatest producing machine.

The Big Fellows

Carnegie was not always a steel magnate. Rockefeller was not born an oil king. Marshall Field did not open his eyes in the lap of luxury, nor did F. W. Woolworth start his mercantile career with a chain of stores. Each had his humble beginning. No doubt in their very early days of clerkship some employer failed to profit by the brain and latent ability they had. Who can say there are not young men of equal talents now occupying clerkships in small stores

in cities, towns and villages throughout the country? Time will tell.

The Value of Incentive

To bring out in any progressive young man or woman his strongest, most intelligent and pains-taking efforts, merchants and storekeepers, retailers as well as wholesalers, are realizing the value of offering a special inducement—an incentive. The extra compensation will be returned many fold. A yearly or semi-annual bonus in the form of a percentage of the profits is often given, or a commission on increased sales in the clerks' department, and frequently special commissions are paid to speed up the sale of the slow-moving merchandise. There are many variations of the idea, all for the mutual benefit of the employer and employe. No progressive storekeeper will hesitate to adopt such a plan, for he will see at once that anything which will enthrall his employes to sell greater quantities of merchandise will mean largely increased profits for himself, and he'll be only too happy to allow the clerks a reasonable share of what they have produced by their additional energy and fidelity.

A Practical Suggestion

What better way to sell phonograph records, especially the earlier numbers? An extra commission on slow-moving numbers would stir up the clerks in charge to unusual activity. They would work overtime; would canvass your customers in their off hours; would seek out new customers, and would devise ingenious advertising schemes to boost the sales in their department, not alone on slow numbers, but on all numbers. Such a plan would put spirit, dash and permanency into the organization. It would advertise your store as an up-to-the-minute, progressive enterprise of the first magnitude.

This idea applies equally to the small store as well as the larger one. Try it. It cannot fail.

Delpheon
the
Incomparable

A tone that is ineffably exquisite—not phonographic



Delpheon \$75 Model

THE DELPHEON COMPANY
BAY CITY :: :: MICHIGAN
OR WRITE TO DISTRIBUTORS

THE TRADE IN BOSTON AND NEW ENGLAND

JOHN H. WILSON, MANAGER, 324 WASHINGTON STREET, BOSTON, MASS.

BOSTON, MASS., November 5.—The Liberty Loan and the epidemic of influenza, which have monopolized public attention for several weeks, each in its own way to be sure, have not overlooked Boston. So far as the loan is concerned the talking machine industry came to the front in good shape, and every house in the city has made quite a record for itself in the number and amount of subscriptions. Now comes the big drive for the allied welfare interests and this, too, will find many friends among the same industry.

In the meantime, the epidemic was an unwelcome visitor in Boston's midst. It hit business pretty hard here, and in some cases badly crippled the jobbers and dealers, who had to work with lessened volume of labor. While many persons were out ill for short or long periods of time the fatalities happily were very few.

Secure Records for the Fighters

The week just ended was designated "Records-for-Fighters Week," and was devoted, as in other places, to a campaign for records for the use of enlisted men in various branches of the service. A number of the Boston talking machine dealers featured the campaign in their advertisements, and one could not pass some of the windows without having his or her attention attracted to the campaign into which the stores threw themselves with great vigor. The sum total of records promises to be a notable contribution to the welfare of the soldiers in service.

Some Brunswick Phonograph News

The Brunswick-Balke-Collender Co. has just had a carload of machines arrive, and there is no difficulty experienced in disposing of them, for business in general with this headquarters is very good. F. J. Smith, who has been associated with the company for eight years in other of its departments, is now devoting his time to the Brunswick line of machines as the successor to F. H. Walter. Mr. Smith was up to Pittsfield, in the western part of the State, a while ago giving a demonstration of the Brunswick at the headquarters of Rice & Kelly, talking machine dealers, and there were so many inquiries about the Brunswick proposition because of the good impression that it made that the house has a number of good prospects ahead. M. J. Graff, who was with the Brunswick's Boston house for a time, coming here from the Western factory, is now in service and is at

the Great Lakes Naval Training Station. Mr. Walter, who went into service last month, has been heard from at Pelham Bay, N. Y.

Escaped Ravages of the Grip

When the Pardee-Ellenberger Co. gets a consignment of Edison goods at its Oliver street quarters it is a case of shaking the dice to see what dealer gets the goods. That's how Manager Frederick Silliman facetiously puts it. This headquarters was most fortunate in being able to escape the ravages of the grip, but Manager Silliman took the precaution to have the women bring their lunches and at the same time he kept the traveling men in, for in the meantime there was work enough for them to do right inside. A wise step!

Business Coming Along Pretty Swift

H. L. Coombs, of the Boston offices of the Emerson Co., is getting rapidly acclimated to Boston, and is finding everything to his liking, especially now that he has got pleasantly located in Brookline. Business is coming along pretty swift these days, and Mr. Coombs has been obliged to rearrange his suite of offices so as to get larger stock quarters. The new issues of Emerson records are finding favor with all the dealers, so reports Mr. Coombs.

Vocalion Co. Activity

The Vocalion Co. is sending out 1,000 letters to prospective customers calling attention to the merits of the instrument, and those receiving these letters cannot but be impressed with the handsome letter head which adorns the paper, for it is both artistic and striking. Manager Hindley did a very clever stroke the other day when he was able to get a Vocalion machine installed into the third act of "Billeted," which Miss Margaret Anglin is playing at the Hollis Street Theatre. The machine is used to great advantage and plays an important part in the development of the final minutes of the scene. Manager Hindley has added to his staff Frank B. Lincoln, who was the manager of the talking machine department of Timothy Smith Co. in Roxbury. Mr. Lincoln comes to Manager Hindley as a Vocalion enthusiast, for he had become acquainted with the instrument while with the Roxbury house, which carried it.

Emphasize the Importance of Music

In the Boylston street window of the C. C. Harvey Co. there is a series of low panels stretching around from side to side which are attracting considerable attention. There are

ten of these panels and they are a part of the National Child Welfare Exhibit, which is now touring the country. These panels, which are in colors, indicate the importance of music to the growing child and every phase of youthful development is incorporated in some pleasing manner. This house features the Victor and the Edison lines, and for both of these Manager White reports there is a good demand.

General Trend of Business Pleases

Frank S. Horning, the Victor factory representative mentioned last month as having lately come upon the scene, tells The World correspondent that he is well satisfied with the general trend of Victor business in this territory. He has made the acquaintance of all the Victor dealers hereabouts, is enthusiastic over the type of men that handle the company's product here and finds an eager disposition to boost the business in every legitimate manner possible. Particularly is he impressed with the uniform courtesy to help brother dealers in these days when there is a recognized shortage of goods. As for Boston, he is getting to like the old town the longer he stays here, he says.

To Distribute the OkeH Records

Richard Nelson, local manager of the Sonora Co., has been over in New York the past few days making final arrangements for the receipt of large quantities of the OkeH records, which are being put out by the Otto Heineman Co. everywhere with great success. Mr. Nelson has had these records for distribution among dealers for the past three weeks, and he reports that there has been a wide demand for them throughout this territory. Joseph H. Burke, associate manager of the Sonora, who has been making his headquarters for the most part in Hartford, Conn., for the past few months, is now dividing his time between there and the local office, as there is much work for him to do on this end.

It Is Now Lieut. Chas. F. Simes

The Veeco Co., manufacturers of the Veeco electric motors for talking machines, 248 Boylston street, of this city, report that from inquiries and orders now being received, manufacturers are very much interested in the Veeco motor. Existing conditions prevent the filling of orders as promptly as the company would like, but it is hoped that the situation will be relieved shortly.

Charles F. Simes, formerly sales manager of

Behind the Co-operation

we are now extending in Eastern Victor Service lies the hope, that when the great world war has come to a victorious close we may look back on a period during which we attained a reputation among Victor dealers for giving practical help to them in the solution of their war-time problems.

EASTERN TALKING MACHINE CO.

177 TREMONT STREET

BOSTON, MASS.

Send for Descriptive Circular

Curry DEMONSTRATION BOOTHS
AND RECORD CASES
IN STOCK OR TO ORDER

"SOUND PROOF"

FRANK B. CURRY
19 Wareham St. Boston, Mass.

the Veeco Co., who enlisted in the 102nd Field Artillery as a private as soon as war was declared, has just been made a second lieutenant of Artillery in France, according to advices received this week. The 102nd Field Artillery was a part of the 26th Division that has fought almost continuously from January to July. Mr. Simes was wounded in action and spent some time in a Base Hospital. He worked his way up through the various non-commissioned grades, and was finally sent to a school of instruction for officers where he won his commission.

Leaves on a Sad Errand

Ricardo Constantino, in charge of the foreign record department of the Grafonola Co. of New England, has hurried across the continent to be with his father, Florencio Constantino, the Spanish tenor, who is said to be dying at Los Angeles, Cal. The son has been with the Grafonola Co., under Manager Arthur C. Erisman, for some time and is highly esteemed by the trade.

An Attractive Window Background

In the large show window of the Vocalion Co. in Boylston street is a fivefold screen which serves as a background for the Vocalion



Novel Window Arrangement

exhibit. The paintings in each panel are thoroughly warlike and they are the work of Miss E. Tremaine, of the Massachusetts Normal Art School. The central panel, which is more than six feet high, shows an American soldier and sailor listening to the strains of "The Star Spangled Banner," which float from a nearby Vocalion. In the background the national colors are suggested in the sky effect, but this is not brought out in the photograph. In the other panels one sees a British soldier, an Ital-

The
CHENEY
PHONOGRAPH

"Plays all records better"

Large surplus stock now in New York City for immediate deliveries in New York and Northern New Jersey.

Write for Catalog and attractive Agency proposition.

BURTON COLLVER
Rep. New York and Northern New Jersey

4 West 40th Street
NEW YORK CITY

Telephone
Murray Hill 6576

ian, a French and a Belgian, each listening to his own native air. The body of the panels is of a cream white. The screen has attracted a great deal of attention from passers-by.

Featuring the Edison Line

The F. H. Thomas Co., whose headquarters in the Back Bay are admirably located to meet a select class of customers within a limited zone, is featuring the Edison Diamond Disc phonograph. The official laboratory model is specifically mentioned in the company's literature, and this model is finding many purchasers.

Increasing Call for Cheney Phonographs

H. L. Royer continues to meet with marked success in exploiting the merits of the Cheney phonograph, and he is constantly getting inquiries from leading dealers and heads of homes who are anxious to possess what appeals to them as a leading type of talking machine. Two dealers who have recently taken on the Cheney line are A. E. Phenny, of Hyde Park, and John J. Kelley, of Lynn, the latter having placed a large order for machines. George J. Krum-

scheid, who, as Mr. Royer's outside man, is meeting with marked success in interesting dealers in the Cheney, could get around better if only his Maxwell wouldn't balk so. His car is not acting half so well as Mr. Royer's little Dodge, which gets him everywhere in short order.

Thos. W. Hindley to Marry

Thomas W. Hindley, manager of the Vocalion Co., is soon to become a benedict. Within a few weeks probably he will marry Miss Ethel Hudson Hayden, of Watertown, who has been his secretary and cashier at the Boston store. It is Mr. Hindley's purpose to find a home either in Watertown or Belmont, either of which is quite convenient to the downtown business section of the city.

Issue Attractive Booklet

The New England Talking Machine Co., 16-18 Beach street, manufacturers of the well-known "Perfection" line of phonograph accessories, have recently issued a very attractive booklet on their line of "Perfection" Flexitone re-

(Continued on page 24)

**— Oldest and Largest
Manufacturers of Talking
Machine Needles in the
World—There are several reasons**

W. H. BAGSHAW CO., Lowell, Mass.

THE TRADE IN BOSTON AND NEW ENGLAND (Continued from page 23)

producers, and "Pur-I-Tone" reproducers and "Perfection" ball bearing tone arms. Adequate space is given in the description to the qualities and accomplishments of each individual number and the booklet is well illustrated throughout.

Manager Mann Sees Better Future

Manager Fred Mann sees a better future for the Columbia line as well as for the talking machine business in general than in some time past. Dealers with whom he comes closely in contact everywhere report a steadily increasing demand for Columbia products and owners of machines eagerly look forward to the appearance of the new record lists. It is not easy these days to keep dealers in a happy frame of mind when orders usually far exceed a company's ability to fill, but Manager Mann and his large and well-ordered staff exercise the utmost fairness in dealing with dealers, and in the long run there is little complaint.

Pathé Supply Improving

The supply of Pathé goods is coming along considerably better these past few weeks, which has enabled Manager R. O. Ainslie to make a fairly liberal provision to the trade. The staff of demonstrators, mentioned a couple of months ago as having undertaken the job of enlisting the attention of the public in the outlying sections, has been able to gather in an encouraging number of prospects.

Pittsburgh Columbia Manager in Town

A visitor to the wholesale department of the Columbia the latter part of October was S. H. Nichols, manager of the Pittsburgh, Pa., office of the company. He came over to discuss some business matters with Manager Mann. C. E. Sheppard, of this company, mentioned last month as having passed through a terrible ordeal because of the epidemic, is back at work, but has not yet fully regained his strength. Both the anxiety incident to the death of both his wife and brother and the serious illness of his child and himself told upon him consider-

ably. All his Columbia associates, however, with whom Mr. Sheppard is very popular, are glad to again have him with them.

Business Good With Ditson Co.

Business continues good at the Oliver Ditson Co.'s Victor headquarters, where Henry A. Winkelman, the manager, is able to keep his trade sufficiently supplied with Victor goods to meet all pressing needs. The October business here was very satisfactory, the house experiencing the response to the general request of the

WM. J. FITZGERALD, BUSINESS MANAGER OF EASTERN CO.

Takes Charge of Well-Known Boston House Following the Death of President Elton F. Taft, Whose Passing Has Caused Universal Regret in the Trade

BOSTON, MASS., November 4.—The Boston talking machine trade was shocked about the middle of October to learn of the death of Elton F. Taft, president and general manager of the Eastern Talking Machine Co. at his home in Brookline. Mr. Taft had been ill only a short time and because of a weak heart could not survive the shock following an operation. Because of the prevalence of the epidemic the funeral was private, but there were floral offerings from many friends and business associates, one tribute coming from the Victor Co. The burial was in Forest Hills Cemetery.

Mr. Taft was a native of Providence, R. I., and was forty-five years of age. Before coming to this city he was employed by J. A. Foster & Co., talking machine dealers in Providence. For a time he traveled for Thomas A. Edison through New England and during this period he made a host of friends in the territory, and with many of these he continued to have close business relations the rest of his life. When the late W. H. Beck was the president of the Eastern Talking Machine Co. he brought Mr. Taft into the concern. That was eighteen years ago. He made Mr. Taft general manager, and when Mr. Beck died four years ago Mr. Taft

authorities that the public begin their Christmas shopping early. It looks like a busy November for this house.

Secures the Pathé Agency

M. J. Sullivan, Inc., of Lawrence, Mass., who recently secured the exclusive agency for the Pathé phonograph and records in this city, inaugurated the opening of their Pathé department last week with great success. The Pathé department was crowded all day and far into the evening of the opening day, and prospects for an excellent business during the coming season are very bright.

was selected to succeed him, and he had held that position ever since. Mr. Taft belonged to no organizations and was essentially a home



Wm. J. Fitzgerald

man. He always paid the strictest attention to business, but the trade at large got a glimpse of him now and then on the occasion of the large talking machine gatherings which he found time to attend. He is survived by his widow and one son, Elton C. Taft, now in the navy.

It was fortunate for the Eastern Talking Machine Co. that in the death of Mr. Taft there is an experienced man to succeed him. This man is William J. Fitzgerald, who learned the business under the watchful eye of Mr. Taft, who always regarded him most highly. Mr. Fitzgerald is to be business manager, and he assumes his new post following a seventeen years' association with the company. For two years and a half Mr. Fitzgerald traveled for the company and was thus brought into intimate relations with the leading men in the trade, the Victor in particular. For some time past he has been wholesale manager. He has often been sought by other houses, but he has been faithful to the Eastern Co. and Mr. Taft, with whom his relations have always been most pleasant. In his travels he has gone off on special missions for Mr. Taft and to his credit it may be said that during the long period of a scarcity of goods due to war conditions probably few jobbers have so well satisfied their clientele as has Mr. Fitzgerald, as he has been able to purchase records from points as far as the distant South, and in this way he has been able to keep his company in the foreground. Mr. Fitzgerald possesses rare tact, good judgment and an even disposition, qualifications that have played a conspicuous part in bringing him and the company, of which he now is business manager, to its present high standard.

A. Cohn has opened a new store in Bakersfield, Cal., for the handling of Brunswick phonographs and Pathé records.

When you refuse to recognize your opponent's ability, you do yourself, as well as him, an injustice.

MANUFACTURERS— JOBBER—DEALERS



Perfection Universal Tone Arm and Reproducer No. 6 set in position for playing "lateral" cut records.

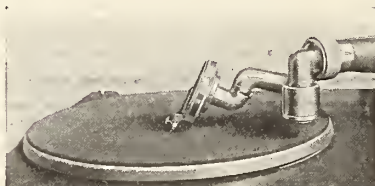

Perfection Universal Tone Arm and Reproducer No. 6 set in position for playing "hill and dale" cut records.

Our PERFECTION line of tone arms and reproducers are now complete and are attachable as follows:

No. 3 tone arm and PUR-I-TONE reproducer plays Victor and Columbia records on Edison Disc Machines.

No. 4 tone arm and Nos. 4, 7 and 8 PUR-I-TONE reproducers play Victor and Columbia records on Edison Disc Machines.

No. 5 tone arm with PUR-I-TONE reproducer plays all makes of hill and dale records on Edison Disc Machines.

No. 6 UNIVERSAL tone arm and PUR-I-TONE reproducer plays ALL makes of records on Edison Disc Machines.

Nos. 3 and 7 PUR-I-TONE reproducers are fitted to Columbia machines for playing Victor and Columbia records.

No. 7 PUR-I-TONE reproducer is fitted to Victor

machines for playing Victor and Columbia records.

No. 11 PUR-I-TONE reproducer plays all makes of hill and dale records on Victor machines.

No. 11-A PUR-I-TONE reproducer plays all makes of hill and dale records on Columbia machines. No. 11 and 11-A reproducers are especially fitted to Victor and Columbia machines, and are easily the finest built in the world. Guaranteed not to blast on any record, and will reproduce Edison Disc records with perfect clarity of sound, also with excellent volume and resonance of sound.

No. 9 PUR-I-TONE Reproducers fitted to Brunswick machines that have tone arms with detachable reproducers.

First-class high-grade product, finely plated and carefully assembled, making this line the leading phonograph accessory line of the world.

Manufactured by

New England Talking Machine Co.

The Largest Manufacturers of Phonograph Accessories in the World
16-18 BEACH STREET BOSTON, MASS.

Write for prices and information as to how these accessories are attached and used on the leading makes of phonographs

▪ The new large size ▪



Retail at 75 cents

Emerson Phonograph Company INC.

3 West 35th Street

New York

Boston, 80 Boylston St.

Chicago, 7 E. Jackson Boulevard

Emerson
Phonograph
Company, Inc.
3 W. 35th St., N. Y.

Please send me
information about the new
large size Emerson Records.

Name

City

State



"Traviata"

Barrientos and Lazaro in their *first* concerted number—this month. It's "Parigi O Cara," the tremendous climax of Verdi's most dramatic opera.

Columbia Graphophone Co.
NEW YORK

DAMBOIS WITH THE AEOLIAN CO.

Distinguished Belgian 'Cellist to Make Vocalion Records Exclusively—A Valuable Acquisition

Maurice Dambois, the famous Belgian 'cellist, has consummated arrangements with the Aeolian Co., whereby he will make Vocalion records exclusively. This famous 'cellist is noted for the quality of his tone, which is unsurpassed in its purity and depth, and his interpretations are characterized by a wealth of poetic feeling. The company makes the claim "that the Vocalion records of his (Maurice Dambois) art are the most beautiful phonograph reproductions of 'cello music ever heard. Appealing and sympathetic as the 'cello is always, the Dambois Vocalion records bring out in perfection the natural beauty of the instrument and present a wonderful tone-picture of the playing of this master 'cellist."

A POPULAR PLACE TO VISIT

Large Demonstrating Room at Lord & Taylor's Victrola Department Fitted Up as Nursery

There is no more popular place in the vast Lord & Taylor establishment in New York than the Victrola department. Children as well as grownups are to be found there, for one of the spacious demonstrating rooms has been fitted up as a nursery with games and toys, and more especially a small-sized Victrola, on which is always heard interesting children's records, both educational and entertaining. While their parents shop, the children have a great time enjoying their games and the Victrola music. It is a great idea and one that will doubtless appeal to other big stores throughout the country.

CURTAIL NEEDLE PRODUCTION

The War Industries Board has just issued an order curtailing the production of sixteen industries for the purpose of saving fuel, labor, capital, material and transportation for essential war work. Among those enumerated are the manufacture of talking machine needles, the curtailment being 50 per cent. of the 1917 production.

SECURED RECORDS FOR SOLDIERS

The talking machine department of the Outlet Co. in Providence, R. I., was a busy spot the closing week of October, being headquarters for the campaign conducted by the National Record Recruiting Corps of New York for the securing of records for the soldiers. A goodly number was secured.

IMPORT REGULATION ON JEWELS

WASHINGTON, D. C., October 21.—According to a ruling just issued by the War Industries Board, the New General Import License Regulation No. 27 does not include jewels for phonograph needles, which may therefore be imported under the old form of license.

VICTOR TRADE-MARK SHOW CARD

Very Artistic Presentation of the Victor Trade-Mark in Colors Issued for the Use of Dealers—Accompanying Letter Explains Its Value

The Victor Talking Machine Co. have issued a very handsome card in colors of the Victor trade-mark for display in show windows, below which appears the following text: "The famous trade-mark of the Victor Talking Machine Co. is on all genuine Victor instruments and records. 'Victrola' is also the registered trade-mark of this company, designating its products only. Such genuine Victor products are on sale in this store." In this connection the company states:

"The best-known trade-mark in the world—familiar to more Americans than any of the world's great masterpieces.' That is how Collier's Weekly described 'His Master's Voice.' It is a true statement of facts which every Victor dealer has ample reason to contemplate with justifiable pride.

"Publicity alone won't make a trade-mark famous, but quality merchandise backed by the right kind of publicity will, and 'His Master's Voice' owes its popularity to the fact that it has always stood for all that's best in music. The importance of this trade-mark and of our trade-mark word, 'Victrola,' is not perhaps fully realized, and we suggest that you give these cards the greatest possible display.

"The public to-day knows that it pays to seek the trade-mark of the manufacturer as the surest and safest method of identifying quality products. These cards positively identify you as a Victor merchant engaged in marketing the best quality merchandise that human skill and ingenuity can produce. It will pay you to display prominently this 'hall mark of quality' in your show windows."

Germany has proved itself absolutely super-efficient in one way. It has secured the enmity of the whole civilized world.

OFFERING NEW CRYSTOLA STYLES

The Crystola Co., of Cincinnati, Report an Excellent Demand for Their Products, Which Are Steadily Growing in Favor

CINCINNATI, O., November 4.—The Crystola Co., of this city, are placing on the market a number of their latest styles of phonographs, which not only reflect the highest skill of the designer's art, but musically they represent a very high standard. The members of this company have paid particular attention to the matter of tone reproduction and the acoustic properties of their cabinets, with the result that the Crystola phonograph to-day stands as a worthy example of reliable construction in the domain of talking machines.

Business with the company is very brisk, and there is evident an increasing appreciation of the attractiveness of their products. In their advertisement elsewhere the Crystola Co. wish it to be distinctly noted that they manufacture the original Crystola and desire further that it should not be confused with any similar sounding name or combination of names. The Crystola as it is made today is a creation that stands absolutely on its merits and commands support on that basis.

INSTALL SEVEN UNICO BOOTHS

Seven of the latest types of Unico demonstrating booths, made by the Unit Construction Co., Philadelphia, have been installed by the Wilson Avenue Piano & Talking Machine Co., of Chicago. The equipment in connection with these booths is most artistic, and it is conceded that there are few establishments as attractive as the Victor department controlled by this company.

The Unit Construction Co. have won a national reputation for the character of their goods, and are kept as busy as can be filling orders for their equipment from all parts of the country.



AUTOMATIC STOPS

The simplest and most efficient Automatic Stop on the market. They give excellent service, are easily installed and are absolutely guaranteed.

Send 50 cents for Sample Stop

KIRKMAN ENGINEERING CORPORATION, 237 Lafayette St., New York

DON'T BUY—DON'T SELL—DON'T MAKE INFRINGEMENTS

T
H
E

O
R
I
G
I
N
A
L



O
T
H
E
R
S

A
R
E

C
O
P
I
E
S

THE ONLY MECHANICAL PATENT EVER ISSUED

in this country on a Phonograph Cabinet as far as we know

Any Phonograph Cabinet that has the record compartment alongside the instrument as shown in the above illustration is an infringement on the Windsor Patent

DO NOT BE MISLED BY INTERESTED PARTIES

but have a competent patent attorney give you his opinion on this patent

Write the Commissioner of Patents at Washington, D. C., enclosing five cents in currency, for an official copy of Patent No. 1279743 which covers this type of Phonograph Cabinet

WRITE FOR A CATALOGUE

The Windsor Furniture Co.

1420 CARROLL AVE.

ESTABLISHED 1885

CHICAGO, ILL.

EDISON "ROYAL PURPLE" ARTISTS

Taurino Parvis and P. A. Asselin Make First of a Series of Records for the Edison Amberola—Both Have Achieved Wide Fame

In the November supplement of Edison Amberol records are two "Royal Purple" numbers



Taurino Parvis, Italian Baritone sung by artists new to Thomas A. Edison, Inc. Taurino Parvis, the prominent Italian oper-



P. A. Asselin, French Tenor atic baritone, has had a wonderful musical history. He is now singing at the Metropolitan

Opera House in New York City and looks back upon his long and successful engagements at Covent Garden, London, La Scala, Milan, for six seasons, Teatro Colon, Buenos Aires, and seven seasons in Petrograd.

P. A. Asselin was born in Canada. After finishing his musical education he entered upon a concert career and made a brilliant success.

It is the Edison policy to present only the most famous voices on the Royal Purple records. The selections this month are quite in line with this purpose.

GERMAN RECORDS INTERNED

Executive Committee of Talking Machine Dealers' Association of Kentucky Takes Action

LOUISVILLE, Ky., November 3.—The following resolution was unanimously adopted and the list of records below was selected at a meeting of the executive committee of the Talking Machine Dealers' Association of Louisville, Ky., held at Hotel Watterson recently:

"Whereas, Edison, Columbia and Victor record stocks now on hand in the trade generally include vocal selections in the German language and instrumental records of German airs, and

"Whereas, traffic in these German records, or the playing of them is not consistent with our conception of true Americanism.

"Be it Resolved that there be prepared at once a list of all Victor, Edison and Columbia records in any essential respect German, including other records of a pacifist nature or by organizations or artists of known pro-German tendencies; and that such list be supplied to our membership and the trade, with the recommendation of this committee that the records named therein be immediately withdrawn from stock and interned for the period of the war."

The following are the numbers of records that were interned by all dealers who handle the following lines: Edison, 50; Columbia, 260, and Victor, 575.

On Saturday, October 19, all firms who are members of the Talking Machine Dealers' Association of this city, had on display in their windows these records, featuring them with a ball and chain around them, and had them in a jail, or something around them, to show that they were interned for the duration of the war.

KEEP EVERLASTINGLY AT IT

More Necessary Than Ever Now to Keep Your Name Before the Public

In sending out their wonderfully well selected budget of window hangers and streamers, as well as magazine, educational and agricultural advertising for November, the Victor Talking Machine Co. very succinctly point out: "Keeping everlastingly at it" is a mighty good slogan for any advertiser even in normal times. Today it's more necessary than ever if the advertiser hopes to keep his name before the public and thus retain the prestige and good will it has required years to build."

TALKING MACHINE DEALERS — READ THIS —

"The finest and most delicate pieces of mechanism do not prove efficient unless properly lubricated. Skill, Genius, Invention and Workmanship must have the proper Oil. Stop and consider this when you have to buy an Oil for household use."

NYOIL IS BEST

FOR ANY TALKING MACHINE



Being made in our Watch Oil Dep't, the same care given in refining as in our "Watch Oil," as all gums and impurities are extracted, leaving it Colorless, Odorless and Stainless.

BEWARE OF SCENTED OILS

Machines will not clog if oiled with NYOIL. NYOIL is used by the U. S. Gov't in Army and Navy. A trial order will make a permanent customer of you.

Ladies use NYOIL for Sewing Machines, for it is stainless. Sportsmen find NYOIL best for Guns, for it keeps them from rusting.

NYOIL is put up in 1oz., 3/4 oz. and 8 oz. Bottles, and in Pint, Quart and Gallon Cans.

For Sale by all Talking Machine Supplies Dealers

WILLIAM F. NYE, New Bedford, Mass., U. S. A.

WM. A. SCHREINER GOES TO SPOKANE

Well-Known Dealer Service Man for Columbia Co. Goes With Eilers Music House

William A. Schreiner, long associated with the Columbia Graphophone Co. in New York, most recently as local dealer service man, has recently affiliated himself with the Eilers Music House, Spokane, Wash., where he will have charge of the publicity work for that well-known chain of Grafonola retail stores. Mr. Schreiner's intimate knowledge of service requirements gained by his long experience should insure him success in his new position. Mr. Schreiner was at one time connected with the old Twenty-third street store of the Columbia Co., then went with the F. G. Smith Co. and C. Bauer & Sons, Brooklyn, before occupying his last position with the Columbia Co.

UDELL WORKS VERY ACTIVE

INDIANAPOLIS, IND., November 2.—The Udell Works, this city, report that they are at present enjoying a splendid cabinet business and that owing to existing conditions the chief problem right now is to fill orders and get shipments in the hands of talking machine dealers who have long featured Udell products.

One of the officials of the company states that the Government's order against the introduction of new styles has not affected the company to any degree, and says: "We, of course, have had to confine ourselves to the old patterns, but the truth of the matter is that these have been tried and not found wanting, which is proven by the fact that the trade buys them, sells them and then comes back for more."

EXACT SIZE



WHY NOT ORDER A SAMPLE

FLETCHER Reproducer and **HEAR** the improvement it makes in tone and detail of your records? :: ::

Samples \$4.00. Satisfaction guaranteed or money refunded

FLETCHER-WICKES CO.
6 E. LAKE STREET CHICAGO, ILL.



Magnificent!
“Il Trovatore” and “Carmen” played by the Metropolitan Opera Orchestra! The biggest classic instrumental ever put on a Columbia Record.

Columbia Graphophone Co.
NEW YORK

THREE NEW VICTROLAS

Victor Co. Announces Styles IV, VI and XXV Containing Exclusive Victor Features

The Victor Talking Machine Co. recently issued literature announcing three new Victrolas, IV, VI and XXV.

The new Victrola IV is equipped with sound-ing boards at the aperture of the amplifying compartment; this, with the decided improve-ment in the appearance of cabinet, will serve as a distinct identifying mark in comparison with the Victrola IV-A.

The new Victrola VI is equipped with a re-movable motor board while the improvement in cabinet design is immediately apparent. The new Victrola VI will be supplied in mahogany or oak, and as the need of a mahogany instru-ment of this type has long been recognized this instrument will find a ready market awaiting its public announcement.

The new Victrola XXV is equipped with an enlarged tapering tone arm and new tapering sound box tube.

Shipments of these new styles will soon go forward to wholesalers, and it is very probable that they will reach warerooms in about three to six weeks, according to the distance from the factory.

NEW PATHE RECORD BULLETIN

December List of Pathé Records Presented in Folder of Simplified Design in Keeping With Government's Conservation Plan

In keeping with the Government's request for the conservation of paper and printing mate-rials, the Pathé Frères Phonograph Co. have presented their list of records for December in much simplified form as compared with previous bulletins. The entire bulletin, printed in the form of an eight-page folder, is devoid of any color but black, but is nevertheless attractively arranged and laid out and does not in any sense suggest overeconomy. For the convenience of the dealer the bottom half of the last page has space for the name and address for mailing pur-poses, together with room for the dealer's im-print. When folded over once and fastened with a specially designed Pathé rooster label, the new bulletin may be sent by post most con-veniently.

The front, or title page, bears a portrait of Muratore, and the announcement of his two latest records, namely, “Le Régiment de Sambre et Meuse,” the national marching song of France, and the aria from “Monna Vanna,” both being compositions which will undoubtedly make a wide appeal.

PORTLAND ASSOCIATION MEETS

Oregon Dealers Consider the Plans for Forming a National Association in Trade

PORTLAND, ORE., November 5.—The first meet-ing of the season of the Talking Machine Deal-ers' Association of Portland was held at the Im-perial Hotel recently. The attendance was not as large as at former meetings, owing to the fact that there had been a mistake in sending out the invitations. After dinner the president, E. B. Hyatt, called the meeting to order, and C. A. Althouse read the minutes of the last meeting and then read some letters received from dealers in other cities in the East. The first letter was from the Talking Machine Men, Inc., of New York, in regard to forming a national association of talking machine dealers. The communication was received with great favor and referred to the secretary, C. A. Al-thouse, with instructions to see what action can be taken that may assist in forming a national association. A letter containing resolutions adopted by the Talking Machine Men, Inc., in which they condemned action of Eastern job-bers handling both retail and wholesale trade, was also received. The local association laid the resolutions on the table for the time being until there was a better representation of the Portland dealers present.

L. D. Heater, manager of the Columbia Graphophone Co., tendered his resignation, as he was in wholesale business and didn't think it fair to the other dealers to remain a member of

the association which is composed of retail dealers. The resignation was not accepted and a committee was appointed to wait upon Mr. Heater and ask him to reconsider the matter, as his resignation would be regretted by all the dealers, who considered him a valuable and ef-ficient member of the local association.

A committee was appointed to secure new members and to see that measures be taken to make these meetings enjoyable and profitable to the entire membership.

USES PHONOGRAPH TO LURE SEALS

Voices of Prima Donnas Attract Seals to Within Range of Hunter's Rifle

PORTLAND, ORE., November 2.—A new use has been found for the phonograph by Edward Corfee, a hunter employed by the Washington State Fish and Game Commission, in making it the means to lure the destructive hair seals to their doom. Mr. Corfee, under instructions from the commission, spent several months at Useless, Mutiny and Cultus Bay on the Lower Puget Sound hunting these destructive animals, who prey upon the salmon. It is said that one seal destroys more than a thousand dollars' worth of salmon in a single season.

The phonograph was taken to the beach and the seals no sooner hear the sweet strains of some prima donna than they come above the surface of the water to listen. Then the hunter's rifle would speak and there would be one less seal to diminish the salmon pack.

Have You Suffered from the Needle Shortage?

HERE IS THE REMEDY

The LIBERTY STYLUS, a semi-permanent needle play-ing from 100 to 300 records, will enable you to forget the needle shortage, for *we guarantee prompt deliveries.*

This Stylus is the only semi-permanent needle on the market that can be used, removed at any time, and re-placed in the needle holder, without lessening the tone quality or damaging the record.

The LIBERTY STYLUS is manufactured in full, medium and soft tone, and is marketed in packages of three needles to a package, 50 packages in a box.

Free Samples to the Trade

LIBERTY STYLUS CO., 149 Kirby Avenue, West
 DETROIT, MICHIGAN

COTTON FLOCKS

.. FOR ..

Record Manufacturing

THE PECKHAM MFG. CO., 238 South Street
 NEWARK, N. J.

Three Big Values—Three Big Sellers

Model No. 3
\$125.00

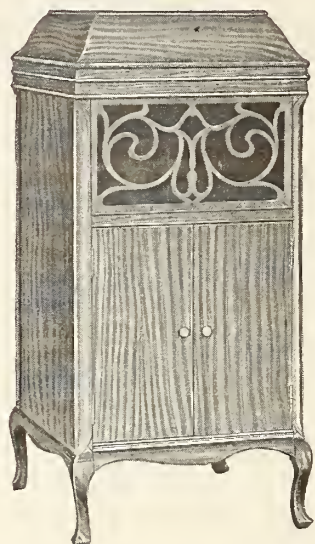

Model No. 6
\$90.00



Model No. 5.
\$75.00

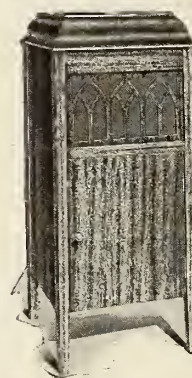

MANDEL PHONOGRAPHS—made by one maker—backed to the limit by the manufacturer, means a service that guarantees your success.

The MANDEL embodies massiveness in cabinet design, efficiency in mechanical construction and richness in tonal quality. These three factors are the making of a good talking machine. And the MANDEL is a good machine.

The three models here illustrated are producing big results for MANDEL dealers. Three popular-priced phonographs—each model giving the consumer greater value for his money than he could ordinarily obtain.

And to the dealer we offer a wonderfully attractive proposition—a co-operative plan that makes it pay him to sell MANDEL Phonographs.

Write for full details—today

A Letter from Missouri—Name and Address on Request

MANDEL MFG. CO.,
Chicago, Ill.

Gentlemen:

Please book my order for immediate shipment by freight, the following:

Two Style No. 3 MANDEL Phonographs, Oak finish.

Two Style No. 3 MANDEL Phonographs, Mahogany finish.

Each purchaser of the MANDEL is delighted with the rich tone value and each sale draws more sales. I sold the last MANDEL today, so please rush out this shipment. I want to keep the MANDEL on my floor. (A MANDEL DEALER)

**MANDEL
MANUFACTURING CO.**

501-511 So. Laflin Street, Chicago, Illinois

The Spirit of Service and Co-operation is Developing in the Talking Machine Industry

The spirit of service, or co-operation, has been developing steadily in all branches of industry. In fact, every day we are realizing how much one leans upon the other. The war in Europe has demonstrated most vividly how Government and business must work hand in hand, each aiding the other, in order to secure the colossal results aimed at in winning the war.

Fighting methods in business will always exist, but they will be along fairer lines, for a reformation is well under way, and the spirit underlying this movement is far stronger than many people imagine. In every-day business we find that the merchant and the manufacturer are working hand in hand to achieve the desired results.

"Service" is the foundation on which a greater and more successful business structure is being built. The manufacturer to-day is spending thousands of dollars preparing suitable advertising matter in the form of catalogs, window display cards, circulars, in fact, all kinds of printed matter most attractively arranged, whereby the talking machine dealer's business is helped, and his path toward success made more easy.

It would seem that this generous offer of co-operation on the part of the manufacturer would be seized upon with avidity by talking machine dealers, and eagerly utilized. Yet we hear of complaints from manufacturers of talking machines who are sending out suitable literary matter in the way of helps and hints to the trade, that their suggestions are not accepted or utilized as they should be. In other

words, there is a lack of that co-operation which is essential to the success of this service plan.

This attitude is somewhat surprising, for the closer the intercourse between the manufacturer and the dealer the better for all concerned. When suggestions are sent out by manufacturers which do not appeal to the dealer he ought to make it a point to write and tell why, and if he can see a better way of handling the



Dealers Should Adopt Every New Idea That Will Enable Them to Meet Competition

subject his suggestions will certainly be received by the manufacturer in the proper spirit. For it takes real co-operation on the part of both manufacturer and dealer to put any suggestion into practice.

It takes time and money on the part of the manufacturer to produce ideas which are distinctly aimed to aid the dealer and to help him

to sell his goods. It should be the duty of the dealer handling the goods of the manufacturer to co-operate enthusiastically so as to put these ideas into use unless they are faulty or can be improved upon.

Manufacturers to-day are giving serious consideration to any and every plan that will tend to help their own and their dealers' business. Many of them have opened bureaus for this purpose under the management of capable men, where special literature is prepared and plans outlined to help dealers promote business in their locality. This is a most commendable plan; it is along those progressive lines that help to build up great enterprises.

But all these efforts are a waste of time unless dealers are alive to the necessity for action. It is certainly disheartening to spend time and money in setting forth ways and means of helping the business of a dealer when he treats with apparent indifference the various sales helps sent out by manufacturers.

Conditions at present render it imperative for the dealer to discard all old-fashioned, antiquated methods of doing business, and to adopt every new idea and method which will help him to meet successfully the keener competition which has developed since the beginning of the war, and the dealer who deliberately disregards and neglects to use those aids which the manufacturers offer him is certainly not conducting his business efficiently, or with a view to securing maximum results in his sales and profits columns.

THE VICTOR TRAVELING FORCE

The Men Who Now Form the Connecting Link Between the Factory and the Dealer

As soon as this country declared war on Germany, the traveling department of The Victor Co., in common with the other important departments of the organization, began to lose men—men who were among the first to answer their country's call and won commissions or enlisted in various branches of the service. With a dozen men of the department in service it became necessary to reorganize the traveling force, which as now constituted is as follows: H. A. Beach, manager; C. Lloyd Enger, assistant manager; L. M. Willis, Texas; Thomas McCreehy, New York City; F. S. Horning, Boston; H. D. Smith, Western New England; J. A. Frye, California and Northwest; H. A. Lamor, New York State; J. E. Dunham, Indiana and Michigan; L. R. Yeager, Chicago; W. F. Fries, Iowa, Minnesota, North and South Dakota; H. A. Brennan, Northern New Jersey and Brook-

lyn; F. McGalliard, Kansas and Missouri; R. S. Cron, Georgia, Florida and Alabama; P. F. Murray, Pittsburgh and Western Pennsylvania; Ben Whitlin, Philadelphia and Eastern Pennsylvania; W. T. Davis, Baltimore, and P. A. Ware, Ohio.

A GREAT EDUCATIONAL FACTOR

The Brooklyn Citizen in a recent article pointed out that the talking machine as an educational factor has tremendous value. Through this means the children can become familiar with all that is best in music, either vocal or instrumental; they can learn not only the music but about the composers, and the great men and women who sing and play various instruments.

VICTROLA FOR THE SOLDIERS

The recreation hall at Ft. St. Philip, which was built in one day as a gift by the Elks Club of New Orleans to the soldiers, is now boasting of a beautiful Victrola, which has been installed by the Philip Werlein Co., Inc.

WARNS OF CREDIT ABUSE

Harding Declares Too Free Use Will Increase Cost of War

W. P. G. Harding of the Federal Reserve Board, in an article in the November number of System on "The Abuse and Use of Credit," says that "too free use of credit will affect us in at least four ways:

"It will make credit for war purposes more difficult to obtain, and consequently higher in price. It will tend to force prices to greater heights, because civilian business will then be able to compete with the Government, and they will bid against each other. This will increase the cost of living, and also the cost of the war. It will impair the strength of our gold reserve, which must be maintained, as we are to remain upon a gold basis.

"Our gold will be one of our strongest assets after the war, and any course which now affects that reserve will hamper us in getting back to a normal peace basis."

The Duo-Tone

EQUIPPED WITH TUNGSTEN NEEDLES

Soft or Loud

without

changing

Thousands of talking machine owners are using the Duo-Tone and De Luxe Needles.

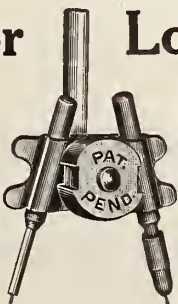

The De Luxe Stylus

SEMI-PERMANENT

Plays 100 to 300 Records

No Scratch or Hiss

Perfect Points

Mr. Dealer: Are you interested in increasing your profits and satisfying your customers? Would you invest \$11.75 to make a quick profit of \$7.45? If so, order at once our attractive Counter Display Stand or Silent Salesman, containing 12 Duo-Tones and 24 packages De Luxe Needles. Descriptive circulars furnished. De Luxe stylus furnished separately. Write for samples and discounts.

The Duo-Tone Company, Ansonia, Conn.

The *Crystola*

is Musically and Scientifically Correct

The Horn is made of Glass. Strange? Not at all.—The Horn should be a REFLECTOR and *not* a sounding board.

On pages 157 and 158 of "The Science of Musical Sounds" appears the following:

"The Horn of itself cannot originate any component tone and hence cannot add anything to the composition of the sound. . . . The Horn is an air resonator and not a sound-board. . . . The walls of the Horn should be *smooth* and *rigid*."

—PROF. DAYTON C. MILLER, D. Sc.
Case School of Applied Science,
Cleveland, Ohio.

Beveled-edge Mirrors — New Diaphragm—Ball-bearing needle finger—etc., etc., are essential and exclusive features that distinguish the CRYSTOLA and make it an instrument of Surpassing Excellence.

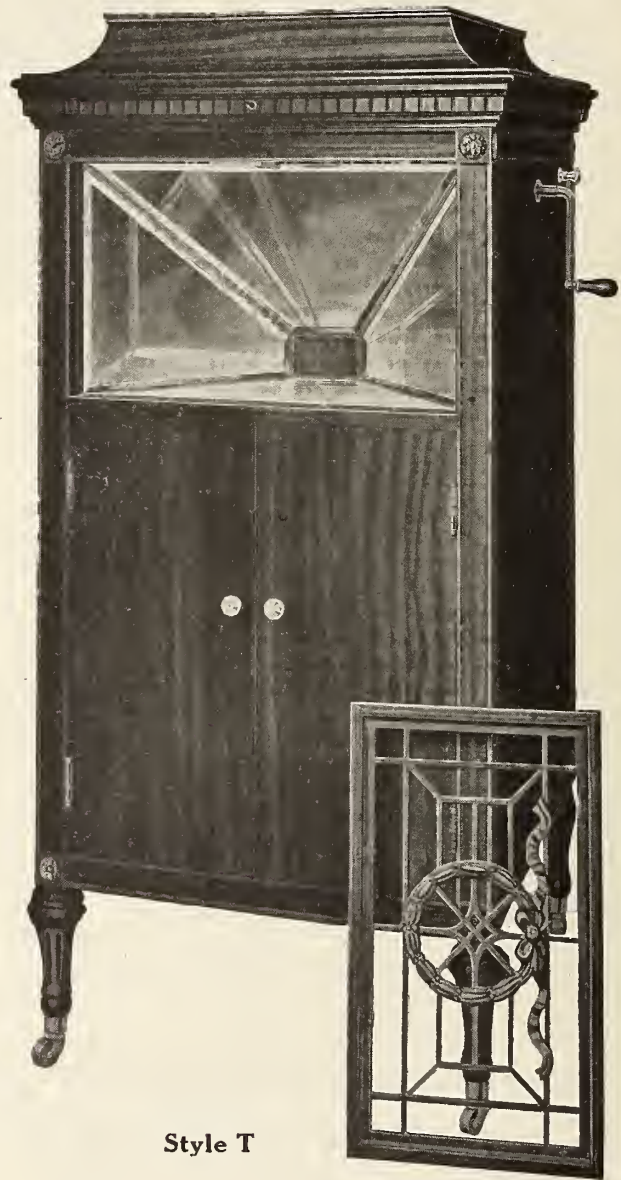

Style T

Your inquiry for New Proposition to Dealers will be welcomed.

The CRYSTOLA COMPANY
Elm and McFarland Streets, Cincinnati, Ohio

Note:— We manufacture the original Crystola. Do not confuse it with any similiar sounding name or combination of names.

Happenings in Dominion of Canada

INFLUENZA EPIDEMIC DISTURBS BUSINESS IN MONTREAL

Regulation of Business Hours in Retail Establishments Hurts Sales—Numerous New Stores Opened—Changes Among the Salesmen—General News Worth Recording

MONTREAL, CAN., November 4.—The commercial situation has been greatly disturbed by the worst epidemic that has ever visited this city. The retail trade are compelled to close their doors early and open up at 10.30 a. m. As a consequence sales have fallen off very materially. Manufacturing in almost every line of industry is curtailed, owing to the large number of employes that are laid up; this applies as well to the retail as well as wholesale and manufacturing industries. This is a very bad season of the year to have business upset, as it is, owing to the rush of orders that are still to be completed for interior points before the season of navigation closes.

C. O. B. O'Brien's many friends in the trade will undoubtedly be pleased to learn that he is now with C. W. Lindsay, Ltd., as salesman in their phonograph salons. Miss D. H. Faucher, late of Layton Bros., is also connected with Lindsay's in their main store.

Layton Bros. advertise the fact that they have 20,000 records on hand to select from, which include Columbia and Edison makes.

For the convenience of patrons the United Globe Exchange, Geo. J. Lifton, manager, is opening joint branch stores in different districts of Montreal for the exchange and the sale of records. The new store at the corner of Guy and Notre Dame street is now in full operation. The head office is at 204 St. Catherine street, West.

TORONTO DEALERS GOING STRONGLY AFTER PROSPECTS

One Dealer Declares That Only 4 Per Cent. of His Business Came Unsolicited—Describes Methods of Prospect Getting—Some Recent Changes in the Trade—Walter F. Evans a Visitor

TORONTO, CAN., November 3.—“Less than 4 per cent. of my phonograph sales have been to people whom I did not solicit,” said S. C. Thornton, of Dundas, Ont., at the recent convention of Edison dealers in this city. This was over a period of three and one-half years in a town of 5,000 people. Mr. Thornton was addressing the convention on “How I Get Prospects,” and he declared that the town dealer's prospect list is his most valuable asset. In getting prospects he told of two methods: First, from the town assessment rolls he secured the name of every resident, age, occupation, religion, owner or tenant, value of property, number of children and their ages. Worthless names were discarded, the others card indexed with the information. A canvassing campaign was mapped out, the town being worked by wards. For three successive weeks the people were circularized with good live literature. The third one, an Amberola on three days' trial, was offered. At the same time Mr. Thornton conducted an advertising campaign by newspaper, concert programs, etc., and slides in the movie. The show window displays and cards were linked up with the campaign.

The personal canvass then commenced. Out of 200 names selected from the first ward Mr. Thornton stated that he secured between 140 and 150 prospects to 30 per cent. of whom sales were made within a few months. “The rest I followed up in the usual manner and many have since developed into sales,” said Mr. Thornton. “Besides, I secured a good number of piano prospects, also record customers, orders for piano tunings and repair work. The piano tunings paid the cost of advertising and circularizing.

“Second method.” Did it ever occur to you that these days every factory has a large percentage of employes who are earning big wages, and if you could secure their names you would

Quite a number of the local talking machine and piano dealers during the recent “flu” epidemic when the theatres and places of amusement were closed by order of the Board of Health advertised: “Don't be without music because the theatres are closed.” “Sickness does not prevent you having music at home,” etc.

The Ideal Phonograph Co., Sherbrooke, Que., has dissolved partnership and a new firm formed under the same style.

Cassavant Freres, the well-known organ builders of St. Hyacinthe, Que., are now manufacturing talking machines and cabinets.

The Parlor Furniture Mfg. Co., Ltd., Pointe aux Trembles, Que., is manufacturing phonograph cabinets in addition to its regular line of furniture.

The Playola Co., Ltd., Toronto, has opened a Montreal office at 248 St. James street.

V. H. Hopper, who was for some time associated with the Western Gramophone Co., Ltd., Calgary, Alta., branch, has joined the sales staff of the Brunswick Shop, Montreal.

J. Donat Langelier, Ltd., are manufacturing the Disc-O-Phone at their factory in Pointe aux Trembles, Que., and are meeting with success with the placing of this machine in various Canadian centers.

A. T. Pike, late of the Cecilian Co., Toronto, has joined the selling force of Layton Bros., replacing W. W. O'Hara, who resigned to go into business on his own account.

have a valuable list of A-1 prospects? Through a friend I obtained 100 or more names of munition workers making from \$5 to \$10 a day, these I circularized and followed up as I did in former method. I secured even more prospects from this list and eventually sold 50 per cent. of them.”

The Canadian Symphonola Co., Ltd., have been appointed Canadian distributors for Charles H. Elting & Co., Chicago manufacturers of springs, motors and tone arms.

Caroline Lazzari, contralto, of the Chicago Opera Co., Edison artiste, received a warm reception at Massey Hall recently. The R. S. Williams & Sons Co., Ltd., report a good demand for her entire repertoire of Edison recordings.

I. Montagnes has returned to Toronto from a week's combined business and pleasure trip to New York, where he conferred with the Sonora Corp. and arranged for regular deliveries of the models that are not yet being manufactured in Canada.

A. L. E. Davies, who returned to Toronto a short while ago to take charge of the Robert Simpson Co.'s talking machine department, is greatly pleased with the musical progress of his

home city as evidenced by the regular demand for the better class of music. “His Master's Voice” Red Seal records he finds in regular request by homes formerly addicted almost exclusively to popular songs.

Walter F. Evans, head of the well-known music house of Vancouver, B. C., bearing his name, was a recent trade visitor to Eastern points, including Montreal and Toronto. Mr. Evans, who is an aggressive distributor of “His Master's Voice” lines, which he has featured for years, and who is well known in connection with the Heintzman & Co. district agency, had no note of pessimism in his interviews with the Easterners. In Vancouver general business conditions and prospects are better, and altogether the Sunset City continues an attractive residential and business city, the people growing more musical each year and more appreciative of the place of music in individual and national life. Mr. Evans is himself a gifted musician and has contributed largely of his talent toward the musical advancement of this city.

SOME TRADE CHANGES IN WINNIPEG

The Phonograph Shop, Ltd., Marks a New Development in the Local Trade—New Type of Talking Machine Demonstrated by Inventor

WINNIPEG, CAN., November 3.—A tangible proof of the invasion of the phonograph is to be found locally in the fact that the city of Winnipeg now has a shop selling talking machines and records exclusively. A few months ago a company known as the Phonograph Shop, Ltd., of which Arthur G. Joy is the manager, purchased the phonograph business of Cross, Goulding & Skinner and since then have conducted an exclusive phonograph shop in the same premises. They have the franchise in Winnipeg for the Brunswick phonograph and records and also act as selling agents for Columbia Grafonolas and Columbia records.

An unusual program was recently heard at the regular Men's Musical Club recital in this city. A local inventor, S. R. Seabrook, demonstrated to the members of the M. M. C. his newly perfected talking machine in a lengthy lecture recital. The writer was privileged to hear the machine at a private demonstration and was decidedly impressed with certain features of the invention. Mr. Seabrook has been bending all of his efforts of late on the construction of a large machine designed for theatre, public halls and public parks, which he claims will carry three miles and even farther than that over water. It was principally this machine that was used at the lecture recital, although four machines in all were utilized in the demonstration. An exhaustive program of instrumental and vocal numbers was given, and Mr. Seabrook thoroughly explained the new and original features of his machine. Chief among these, it would appear, is a system of forced draught, which intensifies and increases the volume of sound as well as emphasizing the undertones. The elliptical shape of the horn is also, it is

(Continued on page 34)

Talking Machine Supplies and Repair Parts

SPRINGS, SOUND BOX PARTS, NEEDLES

THE RENÉ MANUFACTURING CO.
MONTVALE, NEW JERSEY



Songs at Twilight

Longer evenings now. More time at home for music. That's an idea that brings business—properly pushed.

Columbia Graphophone Co.
NEW YORK

TRADE CONDITIONS IN CANADA

(Continued from page 33)

claimed, an improvement, having the effect of straightening out the sound waves and projecting them in a concentrated area. The composition with which the horn is lined is still another novel feature, and is responsible for the increased clarity obtained. The novelty of the event doubtlessly accounted for the large attendance of people at the lecture recital who seemed greatly interested.

Reinald Werrenrath, the Victor artist, will give a recital in Winnipeg the latter part of November.

The Russian Symphony Orchestra is billed to visit Winnipeg shortly. All Columbia dealers and the Phonograph Shop in particular are using printer's ink most freely, announcing the fact that the only records obtainable of the Russian Symphony Orchestra and Florence Macbeth, the coloratura soprano of the company, are made by the Columbia Co.

Marie Morrissey, contralto, of the Edison staff of artists, with Theodore Speering, violinist, gave a series of ten recitals in Manitoba points recently.

The opera, "Have a Heart," was recently heard here, and J. J. H. McLean & Co., Ltd., report a large call for Victor records of this score.

A BUSY ESTABLISHMENT

The Music Shop, exclusive agents for the Aeolian-Vocalion at 124 South Hill street, Griffin, Ga., report an excellent demand for these instruments; they are making a strong appeal to the people of that territory.

The Mutual
TONE ARMS & SOUND BOXES

Dealers

If you want the best,
be sure that the machines you handle
are equipped with

MUTUAL
TONE ARMS AND
SOUND BOXES

Mutual Talking Machine Co., Inc.
145 West 45th Street, New York

COLUMBIA DEALERS HOLD MEETING

First Gathering of the Fall Season Well Attended—Toscha Seidel Introduced—Mark P. Campbell and G. W. Hopkins Speak

More than 150 Columbia dealers in the metropolitan territory, accompanied by the members of their sales staffs, accepted the invitation of the Columbia Graphophone Co. to be present at the first monthly meeting of the 1918 fall season to be held under the auspices of the local Columbia branch. This meeting,



Toscha Seidel

which was held in the Waldorf Apartments at the Waldorf-Astoria Hotel, was a signal success, and Lambert Friedl, manager of the Columbia Co.'s New York branch, was heartily congratulated by the dealers on the interesting program that he had prepared for their entertainment.

These monthly meetings were inaugurated by Mr. Friedl the early part of 1918, and although their prime purpose was to introduce the mid-month records in order to give the dealers an opportunity to place their orders after receiving an actual demonstration of the records, these meetings have also served to introduce to Columbia representatives many of the new artists who are now making records for the Columbia library. In other words, the dealers were given an opportunity to meet these artists and become personally acquainted with them, thereby welding a personal bond that is invaluable.

At the last meeting Mr. Friedl presided, and in his opening remarks paid a tribute to the loyalty of the Columbia dealers, thanking them for their splendid support during the past year in the face of discouraging conditions. His address contained a timely note of patriot-

ism with an interesting resumé of business conditions as they exist at the present time, and the outlook for the future.

The November mid-month records were then played by O. F. Benz, of the general sales department, and they were enthusiastically received.

Mr. Friedl then introduced Mark P. Campbell, chairman of the Allied Music Trades Committee, Fourth Liberty Loan, who made one of his usual stirring addresses in behalf of the Loan. As a mark of their appreciation of Mr. Campbell's address, and his untiring efforts in behalf of the Loan, the dealers presented him with a handsome total of additional subscriptions which was turned in to the Fourth Liberty Loan through his committee.

The next speaker on the program was George W. Hopkins, general sales manager of the Columbia Graphophone Co., and one of the recognized authorities in the world of wholesale and retail merchandising, who delivered an effective discourse on Columbia Grafonola and Columbia record merchandising, in which he advanced suggestions and ideas that were heartily applauded by everyone present. Mr. Hopkins has been associated with some of the leading mercantile organizations in the country, and his familiarity with every detail of retail merchandising has enabled him to give Columbia representatives invaluable ideas whenever he has an opportunity of addressing them. On Wednesday, for example, he submitted a thought which, if carried out, will undoubtedly increase their record sales 100 per cent. This suggestion is especially opportune at the present time in view of the shortage of machines, and the fact that there is no immediate relief in sight. It therefore behooves the dealers to concentrate on the development of record sales in order to show satisfactory sales totals.

The "star" event of the afternoon was the introduction of Toscha Seidel, the young Russian violinist, who was recently added to the Columbia recording library, and who will make Columbia records exclusively. Mr. Seidel was introduced by Theodore H. Bauer, director of the Columbia Co.'s concert and operatic department, who is responsible in a considerable measure for Mr. Seidel's acquisition to the Columbia recording staff.

Mr. Seidel was enthusiastically received by the Columbia dealers, and his rendition of several standard selections served to emphasize the fact that this young artist, who has been acclaimed by musical critics as one of the leading violinists of the present day, well deserves the praise bestowed upon him in Europe and this country. His Columbia records, which go on sale immediately, were also played for the dealers, and each record was a faithful reproduction of Mr. Seidel's remarkable technique and warmth of expression. This violinist, who inaugurated his 1918 concert season last week, will undoubtedly add to his laurels this year.

Make your quarters grow. Buy Thrift Stamps



KEH RECORDS

WHY WAIT FOR MERCHANDISE?

Waiting Does Not Pay Rent

You Have to Sell Hot Cakes While They Are Hot, and
Hits While They Are Hits

We Will Make Immediate Delivery on the Latest Broadway Hits

1101 { **Smiles—Dance**
Djer Kiss

1074 { **Oh, How I Hate to Get Up in the
Morning—Vocal**
Good Morning, Mr. Zip, Zip, Zip.

1072 { **I'm Sorry I Made You Cry—Vocal**
I Hate to Lose You

1096 { **Everything Is Peaches Down in
Georgia—Vocal**
Lovin'

1107 { **Tell That to the Marines—Vocal**
Ring Out Liberty Bell

1110 { **My Belgian Rose—Vocal**
Dreaming of Home, Sweet Home

1086 { **Smiles—Vocal Duet**
Since I Met Wonderful You

1073 { **When You Come Back—Vocal**
Hearts of the World

1099 { **The Missouri Waltz—Dance**
I'm Gonna Pin a Medal on the Girl
I Left Behind

1106 { **I Ain't Got Weary Yet—Vocal**
K-K-K-Katy

1108 { **Oh, How I Wish I Could Sleep Until
My Daddy Comes Home—Vocal**
What a Wonderful Message from
Home

1112 { **Dear Old Pal of Mine—Vocal**
I'm Gonna Pin a Medal on the Girl
I Left Behind

and others

*Send in Your Order and Cash in on the Popularity of
These Big Numbers*



CHICAGO

Otto Heineman Phonograph Supply Co.

INCORPORATED

25 WEST 45th STREET, NEW YORK

FACTORIES, ELYRIA, O.—NEWARK, N. J.
PUTNAM, CONN. SPRINGFIELD, MASS.

ATLANTA

SEATTLE



TORONTO



CONSERVATION RULES FOR TALKING MACHINE INDUSTRY

Government, Through War Industries Board, Issues Formal Program for Guidance of Manufacturers—Number of Styles Limited, as Is the Use of Metal for Certain Parts and Trimmings—Record Cut-Out System to Be Discontinued and Size of Monthly Lists Reduced 50 Per Cent.

Numerous rumors and many plain guesses have been circulated in the trade as to the curtailment orders that have been issued, or would be issued, covering the manufacture of talking machines and parts. Members of the trade can now rest easy, however, owing to the fact that under date of October 28 the Conservation Division of the War Industries Board at Washington issued its formal notice of curtailment as applied to the talking machine trade. The official notice addressed to manufacturers of talking machines is most plain in its wording, and with introductory comments reads in full as follows:

Records and Needles

In order to meet war requirements and other essential needs it is of primary importance that the country's resources be used to full advantage and that we husband our supplies of material, equipment, labor and capital.

The Conservation Division, in co-operation with numerous industries, is putting into effect plans for saving essential material and equipment, for simplifying manufacturing operation and for reducing the amount of capital tied up in manufacturers', wholesalers' and retailers' stock.

It appears that manufacturers of talking machines are making a greater variety than is necessary in time of war, and that it will be entirely practicable to effect a material reduction as a measure of conservation. It is particularly desirable to eliminate every unnecessary use of steel, which is urgently required for war purposes.

The enclosed program has been drawn up with the assistance and advice of representatives of your industry. It will be made effective, as it is now issued, unless substantial reasons are immediately presented to show that by some modifications the needs of the Government can be met more effectually. If you have any suggestion whereby greater economy can be secured we shall be glad to receive them.

CONSERVATION DIVISION, WAR INDUSTRIES BOARD.

The Conservation Program

Schedule for Manufacturers of Talking Machines, Records and Needles.

Talking Machines

No. 1. Models: Each manufacturer to restrict his production to not more than six standard models or types, but in no case to exceed the number of models or types that he made in 1917. A different cabinet construction constitutes a change in model. Each manufacturer to file with the Miscellaneous Product Section of the War Industries Board specifications of the models he proposes to continue. No change thereafter to be made in models, or new models or types to be introduced or manufactured during the period of the war.

No. 2. Finish: Each manufacturer to restrict the number of finishes in his line to three as follows: one mahogany, either red or brown, as each manufacturer may elect; one golden oak and one fumed oak.

No. 3. Electric Motors: The manufacture of talking machines with electric motors to be discontinued.

No. 4. Name Plates: The use of metals other than zinc for name plates to be discontinued.

No. 5. Casters: The use of casters with metal wheels to be discontinued.

No. 6. Wheels: The use of wheels other than casters to be discontinued.

No. 7. Horns: The manufacture of metal horns to be discontinued.

No. 8. Needle Cups: Metal needle cups to be eliminated.

No. 9. Locks and Keys: Locks and keys to be eliminated.

No. 10. Metal Knobs: Metal knobs on doors or top covers to be eliminated.

No. 11. Record ejector for filing of records to be eliminated.

Records

No. 12. The so-called cut-out system, providing for the return of records by the dealers to manufacturers monthly or annually to be discontinued. This does not apply to records purchased by dealers previous to the date of this schedule.

No. 13. The monthly issue of new records by each manufacturer not to exceed 50 per cent. of his average month's issue during 1917.

No. 14. Record catalogs to be issued not more than one a year and to be as condensed as possible. Each manufacturer now issuing a monthly supplement to reduce it at least 50 per cent.

Needles

No. 15. Each manufacturer to confine his production of metal needles to not more than two styles, size or weight.

No. 16. Needles to be put up in envelopes only.

General

No. 17. Each manufacturer when the supply now on hand is exhausted to discontinue the distribution of metal stands for displaying records.

No. 18. This schedule to be made effective immediately.

B. M. BARUCH, Chairman.
315-650, October 28, 1918.

CHRISTINE MILLER SINGS AT CAMPS

Christine Miller, the prominent Edison star, has been called to Washington, D. C., by the National War Work Council to make arrangements for a tour of about twenty army camps in the Eastern and Southeastern States. Miss Miller's first engagement was at Camp Lee, Va., where she sang before an audience of about 3,000 enthusiastic soldiers. It will take her some weeks to complete the tour as outlined by the National War Work Council.

STEADY GROWTH IN FRENCH TRADE

In a table of imports into France covering the years 1916-17, prepared by Consul-General Thackara in Paris, and designed to show the trend of French trade with the United States during those years, it is found that musical instruments to the value of \$234,822 were imported into France from the United States in 1917, as compared to a total of \$183,345 imported for the year 1916, a gain of something over 25 per cent.

The
Scotford Tonearm
and
Superior Universal Reproducer
The Ideal
Combination
Plays All Makes of Records
as they should be played
Price of Sample Prepaid
Nickel, \$5.25 Gold, \$6.50
Adjusted for Cabinet
measuring 8 1/2 inches from center of Tonearm
base to center of Turntable shaft

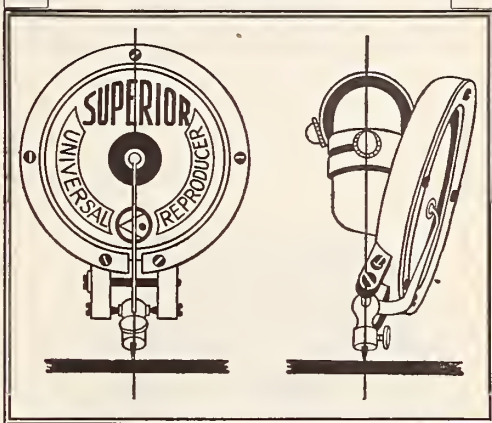

Distinctive Features

- The Reproducer pivots on its axis (as illustrated above), taking the correct angle for all makes of records, and the needle retains same center in both positions.
- Surface noise is less than with any other reproducer—surface scratchings being reduced to a minimum through perfect proportioning of the stylus construction, and placing the needle in the center of the groove at the correct angle.
- The split construction of the frame and face ring of the Reproducer, together with the method of pivoting the stylus bar, and perfect insulation—effect a sensitive and free vibration—and prevent a pinched tone resulting at any time from natural contraction or expansion of the metal parts.
- The reproduction is the mellow, natural quality of tone—absolutely getting away from the usual sharpness and metallic effect so noticeable in most reproducers.
- Sound waves act upon the same principle as light waves—they travel in a straight line until they meet some obstruction, from which they are deflected at right angles. The right angle turn at the back of the Scotford Tonearm causes less breaking up and confusion of the sound waves than occurs in the curved arm.
- The connection between the Reproducer and Tonearm is perfectly insulated with a hard rubber bushing. Inside diameter of the Tonearm is correct to accommodate the volume obtained from the latest records.
- The right-side turn for changing needle is handier than the old style turn-back, and when in position for the Hill-and-Dale records there is no interference with lowering the cabinet cover.
- The lateral movement at the base is simple, free and permanently satisfactory. Inside there is no obstruction to interfere with passage of the sound waves. There are no loose balls in the bearings, therefore no buzzing noise can occur from the great vibration on high notes.

Barnhart Brothers & Spindler
Monroe and Throop Streets—Chicago

"MAGNET" DECALCOMANIE NAMEPLATES

FOR TALKING MACHINE CABINETS ETC.

Pamphlets with fac-simile illustrations and prices mailed on request.

SMITH-SCHIFFLIN CO.
126 Liberty Street New York City

From the
DORAN CO.
115 HURON AVE.
DETROIT

SOLD BY
HURTEAU, WILLIAMS & CO.
MONTREAL — OTTAWA

Kunkel Piano Co.
BALTIMORE

FROM
THE PHONOGRAPH CO.
1240 HURON ROAD (East Side Ave.)
PHONES - 4-1000 4-1001 4-1002
CLEVELAND

SOLD BY
WALTER D. MOSES & CO.
103 E. BROAD STREET
RICHMOND, VA.

SOLD BY
J. E. STRATFORD
AUGUSTA, GA.

Wholesale Representation Desired in Large Distributing Centers

Very advantageous connections can be made at this time. WRITE NOW!

The **Tel-O-Tone** has a number of new and strong talking and selling points not to be found in any other phonograph. Let us tell you more!

We have passed and left behind the days of experimentation

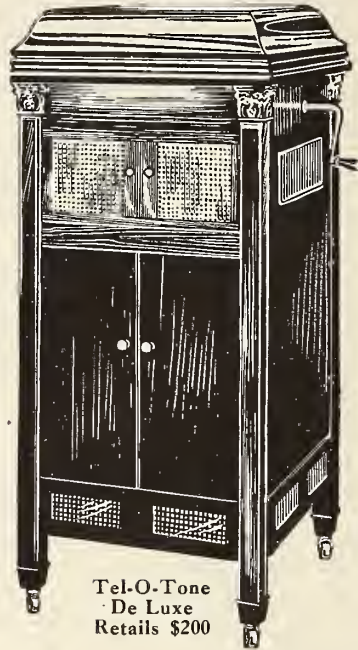

Tel-O-Tone
De Luxe
Retails \$200

Our guarantee affords, as few others can, unlimited insurance to wholesaler and retailer alike.



Tel-O-Tone
Standard
Retails \$160

Tel-O-Tone

(Reg. U. S. Pat. Off.)

*"The Soul of Music
Dwells Within"*



Tel-O-Tone
Encore
Retails \$110

Our specifications are absolutely standard throughout; equipment, material and workmanship of highest obtainable quality

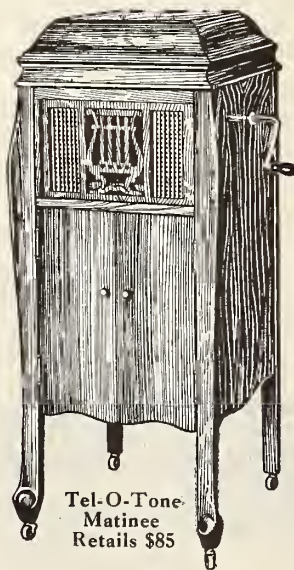

Tel-O-Tone
Matinee
Retails \$85

We claim unequalled clearness of reproduction and challenge comparisons.

The Western News Company, 21-29 East Austin Ave., Chicago, Ill.

Retail Display Room, 730 Republic Building, Chicago, Ill., U. S. A.

TALKING MACHINE BEING FEATURED

Milwaukee Association of Music Industries Wins Praise for the Quality and Excellence of the Page Advertising Now Being Issued

MILWAUKEE, Wis., November 2.—The Milwaukee Association of Music Industries, originator of the co-operative method of music advertising, which began its third campaign on October 18 by the publication of a full-page advertisement dealing mainly with the value of the musical instrument in the home under present-day conditions, is arousing the enthusiasm of its members as the subsequent advertisements appear.

The advertising drive embraces a period of ten weeks, during which an average of two full pages will be published each week. The second advertisement told of "The Magic of the Phonograph" in suiting every mood with music, and as may be seen from the illustration herewith was confined purely to a talking machine sales talk. The third was devoted to music roll advertising, and the others which will follow, treating of various phases of the industry, will be of like interest.

The expense of this, as well as previous campaigns, is borne by the association, which raises such special funds by the voluntary subscriptions of its members, who are asked to contribute according to the volume of business they do. In this manner \$4,000 was raised a year ago; \$1,200 last spring, and \$1,200 during the past month, or a total of nearly \$6,500 to cover three drives. The names of all members of the association are published in connection with each advertisement under the trade-mark and corporate title of the organization.

Individual members of the association find it exceedingly profitable to re-enforce the co-operative ads with smaller ones of their own, effectively linking up the general campaign with their particular stores. This plan also has produced some very excellent "copy." The as-

sociation campaign is being conducted through the medium of the Milwaukee Journal, which has by far the largest circulation of any local newspaper. The advertising department of this paper is giving the association and individual

Music to Suit Your Mood



AT THE TIPS of your fingers you have the music that you love, whenever it suits your pleasure, through the magic of the phonograph. Within this wonder-working cabinet is confined the whole realm of music—yours to release at will. Whether it be vocal or instrumental music, opera or folk song, patriotic or sentimental, ragtime or classic, you have it faithfully reproduced at your command by the talking machine.

Without stepping from your door you are entertained by great singers, thrilled by stirring marches, filled by sweet melodies, inspired by patriotic airs, or brought to your feet by impetuous dance music. No matter what your mood, there is music to fit. If you want to dance, you have the quiet dreamy waltz, or the snappy fox-trot. The favorite selections of every member of the family are recorded on the discs, ready for all to enjoy.

Not for a long time, and perhaps never again, will you be able to buy that Phonograph at the price you can buy it today. The terms of payment make it easy for you to have music in your home.

MILWAUKEE ASSOCIATION OF MUSIC INDUSTRIES INC.

Music Dealers Who Make It Easy for You to Buy with Confidence

Table listing various music dealers and their addresses across different cities like Chicago, Milwaukee, and St. Paul.

Association Ad on Talking Machines members as well the benefit of its planning and production service without charge.

There is no question that the sales of talking machines, pianos, rolls and records will be stimulated to a higher degree by this publicity

campaign, and Paul F. Netzow, chairman, and C. L. Dennis, secretary of the National Association of Piano Merchants, who are actively interested in this work, are to be complimented on the success so far achieved.

VICTOR SUPPLEMENT FOR DECEMBER

List of "Best Sellers" Contained in December Supplement—No New Records Listed

The Victor Talking Machine Co. has recently issued an announcement to the trade calling attention to the December Supplement which has just been issued, and which contains a selected list of records for which there has been so great a demand that it has been impossible to keep dealers supplied with adequate stocks of the same. No new records are to be listed for December, this being the first time that the established precedent of issuing new records at the first of the month has not been followed. All of the record manufacturing facilities of the company have been concentrated on the records listed in the December Supplement, and the Victor Co. is endeavoring to catch up with the demand for these records this month. The January Supplement will offer new records in accordance with the usual custom, and in addition a supplement will be issued containing foreign-language record listings.

COLUMBIA CO. DIVIDEND

The Columbia Graphophone Co. has declared its regular semi-annual dividend of 3 1/2 per cent. on its common and preferred stock, payable November 15 to stock of record November 1.

INCORPORATED

The Royal Talking Machine Corp., Chicago, has been incorporated with a capital stock of \$100,000, with Chas. Hanson, Andrew Olson and E. Robinson.

The Leonard Markels BUTTERFLY MOTOR

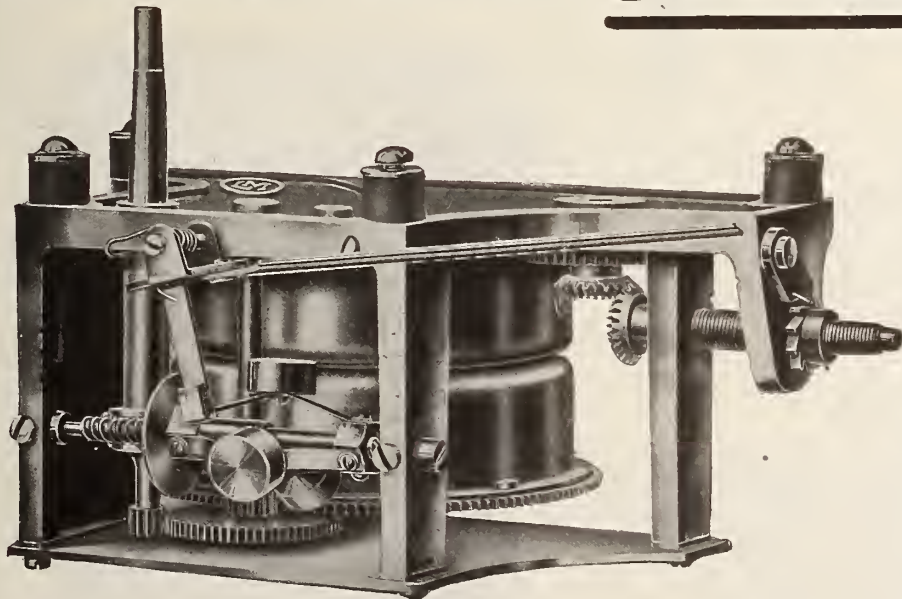

Specifications

- Beveled gear noiseless winding, New ratchet device that prevents clicking. Bakelite intermediate gear—absolutely silent. Plays seven 10-inch or five 12-inch records at one winding. Cast iron nickeled frame. Powerful, durable, compact, accessible. Built especially for the highest-grade machines. Guaranteed in every minutest detail.

The Leonard Markels Jewel Bearing Butterfly Motor

has revolutionized the motor industry. It is silent running and silent winding and represents the acme of perfection in motor construction.

This motor has achieved phenomenal success, and is being used exclusively by leading phonograph manufacturers in all parts of this country and Canada.

Write today for a copy of our New Butterfly folder

LEONARD MARKELS - 165 William St., New York

The most wonderful Talking Machine of the present age at the price
An Instrument of Supreme Value, Tone and Quality

Cleartone

SPEAKS FOR ITSELF



No. 100—\$100



No. 75—\$75



No. 65—\$65

The *Cleartone* has become very popular because of its quality, splendid value and the advertising and sales campaign that now stands in back of it. **Dealers!** Watch us grow—write for our agency and grow with us.

SUNDRY DEPARTMENT

MOTORS—No. 1, double-spring, 10-inch turntable, plays 2 10-inch records, \$3.25; No. 6, double-spring, 10-inch turntable, plays 3 10-inch records, \$4.00, with 12-inch turntable, \$4.25; No. 8, double-spring, 12-inch turntable, plays 3 10-inch records, castiron frame, \$5.85; No. 9, double-spring, 12-inch turntable, plays 3 10-inch records, castiron frame, bevel gear wind, \$6.85; No. 10, double-spring, 12-inch turntable, plays 4 10-inch records, castiron frame, bevel gear wind, \$7.85; No. 11, double-spring, 12-inch turntable, plays 7 10-inch records, castiron frame, bevel gear wind, \$9.75.

TONE ARMS AND REPRODUCERS—Play all records—No. 2, \$1.45 per set; No. 4, \$3.95 per set; No. 6, \$3.75 per set; No. 7, \$3.75 per set; No. 8, \$3.75 per set; No. 9, \$3.25 per set.

MAIN SPRINGS—No. 00, $\frac{3}{8}$ in., 9 ft., 39c. each; No. 01, $\frac{3}{8}$ in., 7 ft., 29c. each; No. 1, $\frac{3}{4}$ in., 10 ft., 49c. each; No. 2, $\frac{1}{2}$ in., 10 ft., 49c. each; No. 3, $\frac{3}{8}$ in., 11 ft., 59c. each; No. 4, 1 in., 10 ft., 59c. each; No. 5, 1 in., 11 ft., heavy, 75c. each; No. 6, $1\frac{1}{4}$ in., 11 ft., 95c. each. We also carry other size main springs to fit Victor, Columbia and all other motors at nominal prices.

RECORDS—POPULAR AND GRAMMAVOX, new 10-inch, double-disc, lateral cut, all instrumental selections 35c. each.

GOVERNOR SPRINGS—To fit VICTOR, COLUMBIA and all other motors at moderate prices. Special prices on large quantities to Motor Manufacturers.

GENUINE DIAMOND POINTS, for playing Edison records, \$1.75 each.

SAPPHIRE POINTS, for playing Edison records, 18c. each.

SAPPHIRE BALLS, for playing Pathé records, 22c. each.

NEEDLES, steel, 75c. per thousand in 10,000 lot.

We also manufacture special machine parts, such as worm gears, stampings, or any screw machine parts for motor; reproducer and part manufacturers.

Special quotations given to quantity buyers in Canada and other export points.

Write for our 84-page catalog, the only one of its kind in America, illustrating 33 different styles of talking machines and over 500 different phonographic parts, also gives description of our efficient Repair Department.

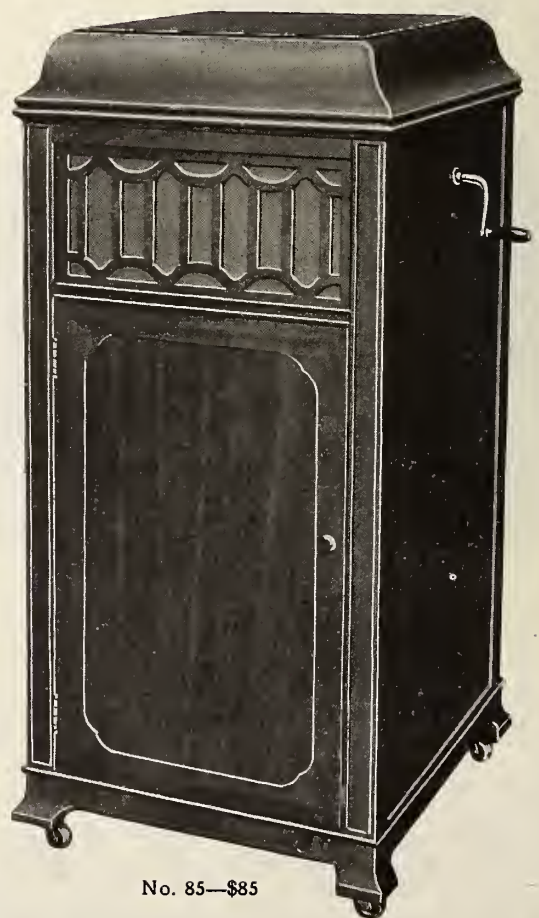

No. 85—\$85

Lucky 13 Phonograph Co., 3 and 46 East 12th St., New York

12-15-25

Do your Christmas selling early. Get your Fall Advertising Campaign going full speed ahead now—you'll be ready for the big spurt of December 15-25.

**Columbia Graphophone Co.
NEW YORK**



LOOK FOR ACTIVE EARLY-HOLIDAY BUSINESS IN BUFFALO

Business Normal Following Lifting of Influenza Ban—Vocalion Line With Denton, Cottier & Daniels—New Business Organization Formed—Help Gather Talking Machines for Soldiers

BUFFALO, N. Y., November 3.—By proclamation of Mayor Buck, of this city, the quarantine laid on Buffalo on account of the Spanish influenza has been lifted. The disease played havoc with the selling forces of the talking machine dealers and jobbers. While no deaths in the trade were recorded several members were tied up at home for a time on account of illness. The opening of all theatres, schools and various other places since the checking of the influenza epidemic and the settlement of the strike have helped to put the early-holiday business in talking machines at full speed. This rush promises to continue right through November and the early part of December, when, according to the advertised wishes of the merchants of Buffalo, most of the Christmas purchases will have been completed.

What is said to be the most extensive advertising campaign ever conducted in Buffalo in connection with the sale of talking machines is now being handled by Denton, Cottier & Daniels, who announce that they "have taken the representation of the Aeolian-Vocalion and the new Vocalion record." This feature news is being heralded broadcast in page ads in the Buffalo newspapers, which are also using columns of news stories about the event. The setup of the ad is similar to that which recently appeared in *The Talking Machine World*, referring to the same subject. The advertisement reiterates what Buffalonians for several generations have known "that Denton, Cottier & Daniels is not only recognized as one of the strongest constructive forces in the music trade, but enjoys the confidence and respect of its public to-day, in a measure rarely equaled in the music or any other industry."

The completion of several specially selected lists of Victor records is announced by Neal, Clark & Neal. These include "patriotic music, dance music and Christmas music."

William H. Daniels, of Denton, Cottier & Daniels; Ralph C. Hudson, president of J. N. Adam & Co., and Edward Hengerer, president of the William Hengerer Co., all of which firms handle talking machines, have been appointed leaders of a new business men's organization, known as the All-for-Buffalo Committee. This was formed to safeguard Buffalo's industrial and commercial life and prevent any further interruption of street car service.

"Caruso Sings HERE" was a sign recently used in the show window of Robert L. Loud, Victrola dealer. This was especially effective at the time of the cancelation of the Caruso concert scheduled for this city. The quarantine was responsible for the closing order. Clifford Ford has been appointed general floor manager of the Loud store.

William H. Rielly, salesman for the Utlej Piano Co., Inc., New Edison dealers, has turned over worth-while contributions to the Soldiers'

Smoke Fund. They were furnished by those whom Mr. Rielly carried in his automobile during the street car strike. Contributions were stimulated by a sign at the side of his car.

"We could use several carloads of Sonoras if we could get them," was the comment of L. M. Cole, Sonora representative, who recently visited Buffalo.

A large holiday order for Pathé talking machines was recently given by the Koenig Piano Co. to A. D. Ogden, New York State representative of the Hallet & Davis Piano Co.

Talking machine dealers who are booming the plan for the purchase of Christmas gifts this month include A. Victor & Co., J. N. Adam & Co., Walbridge & Co., William Hengerer Co., Bing & Nathan, Bricka & Enos, Household Outfitting Co. and Adam, Meldrum & Anderson Co.

Peace that will come from the complete surrender of Germany is advocated by R. C. Schermerhorn, who recently expressed that sentiment in a letter to a Buffalo friend. Mr. Schermerhorn, former manager of the store of Robert L. Loud, Victrola dealer, is now in the Quartermaster's Department at Washington.

The newsboys' booth established in front of the store of A. Victor & Co., Pathéphone jobbers, during the Fourth Liberty Loan campaign, was responsible for the sale of several

thousand dollars' worth of bonds. Entertainment and four-minute speakers were furnished daily at the booth.

While on a recent visit to Buffalo, where she filled an engagement, Mme. Amelita Galli-Curci visited the store of Denton, Cottier & Daniels. There she listened to a few of her records on the Victrola.

Talking machines and other musical instruments for the soldiers at Fort Porter, Buffalo, are being collected by the Chromatic Club.

PLAY VICTROLA AND KEEP HEALTH

That Is the Advice Offered by Omaha Newspaper During Recent Influenza Epidemic

Evidently the Victrola stands high in the opinion of the people of Omaha, Neb. In a recent newspaper story suggesting precautions against catching Spanish influenza it was advised on the authority of the Health Commissioner to "stay at home and don't have any visitors." After pointing out the danger of getting into crowds, or even having a half dozen guests at home, the story reads:

"So the cautious ones will stay at home, keep the windows open, read the religious books or Sunday papers, or play the Victrola. It is also advised by Dr. Manning to go out and take long walks in the open air."

From the stimulated demand for records of all types it is apparent that many people in Omaha took the advice to play the Victrola.

Phonograph Dealers—Attention!

The Fourth Liberty Loan went over big

**"Hook Up" to the Pathe Line and
"Go Over" With Us**

A few desirable territories still open

Write Today

The Fischer Company

(Oldest Pathe Jobbers)

940 CHESTNUT AVENUE

CLEVELAND, O.

THE TRADE IN PHILADELPHIA AND LOCALITY

PHILADELPHIA, Pa., November 6.—The talking machine business in Philadelphia in October showed about the same conditions as the previous month, and was somewhat disappointing in the limited supply of goods that the many dealers were able to maintain. They sold everything they could get, and how much more they could have sold is a question, but they were only able to get about half the amount of stock of October a year ago, and consequently business showed an equal falling off. They do not look for any material change in the coming months—in fact, until the end of the war—but they do not seem discouraged, for they expect to get the business some time.

Columbia Had Good October

The Columbia branch report that they had an excellent business in October. Manager A. J. Heath says: "We have been able to keep our people well supplied with records—especially the popular selling numbers for which there has been a big demand. There has been quite a shortage on machines, although we have received a few shipments which have enabled us to keep our dealers partially supplied." Mr. Heath went to New York hoping that he would be able to speed up shipments. The influenza epidemic played havoc with the Columbia organization, but every one is back again to work with the exception of E. A. Manning, the credit manager, who has been lying at the point of death the past two weeks.

Among the recent Columbia visitors were F. W. Zerker, of York, Pa., and Mr. MacDowell, of the Lauter Co., of Easton, Pa. C. R. Lamm, who was in charge of the trade promotion department of the Columbia, was assigned to one of the Georgia cantonments and was made a sergeant within two months. W. A. Quinn, a former employe, is now in the Naval Reserves.

At the Dictaphone offices the reports are most encouraging. C. K. Woodbridge, the new service manager, has just paid the local offices a visit. Last month was the largest month the Dictaphone has ever had in the volume of sales.

New Brunswick Distributors

Manager C. B. Chew, of the Brunswick phonograph headquarters, spent several days up the State this week. This firm is making big inroads in the business in all sections of the east-

ern part of the State. They report that their business has been very fine. They have been getting in machines promptly the past week, receiving two carloads of Brunswick from Dubuque, Ia., one car containing 183 machines. The J. C. Bright Co., of Lansdale, Pa., one of the largest distributors in this State, have taken on the Brunswick, and are introducing it through their chain of stores. Among the recent Brunswick visitors was P. L. Deutsch, secretary of the company.

Have Felt the Influenza Epidemic

The Penn Phonograph Co. have felt the influenza epidemic and the curtailment of stock, which has sent their business off considerably.

E. Hipple, of their sales force, returned on Monday of this week after an absence of several weeks with the influenza. Among the visitors at the offices was F. K. Dolbeer, well known for a number of years in talking machine circles, but now associated with the Overland Automobile Co. The firm received a postal card this week from one of their former men from the firing line in France—Corporal J. B. Iannarella. He is in the Tank Corps.

Why Louis Buehn Is Optimistic

The Louis Buehn Co. have a very attractive window at present. Mr. Buehn says: "We are selling all the goods we get, and that is not many." But he takes an optimistic view of the situation, and believes that this condition is only temporary. "I am not disgusted nor discouraged," he said, "I know this is not going to last, and later on we will do a better business than ever. Probabilities are that there will be a slight improvement the coming month."

Doing Satisfactory Business

The firm of Blake & Burkart, the largest dealers here in the Edison, report that they had a very satisfactory October, and that they were able to get goods in sufficient quantities to meet their demands. They have been handicapped during the month somewhat on account of the illness of so many of their men. H. C. Trader, of the office force, was at home ill with the influenza for two weeks, and C. J. Levering, one of the salesmen, was also away for the same length of time.

Business in the Edison dictating machine in Philadelphia in October was very good, and considerably ahead of last year. Nelson C. Durand was a visitor in Philadelphia the first week in November.

New Pathé Accounts

Walter Eckhardt, head of the Philadelphia Pathéphone Co., was in an exuberant mood over the business of his firm in October and said: "Business in October was so good I hate to tell about it. We had in October our greatest month in spite of the influenza by more than 63 per cent."

The Pathé Co. during October connected with some very important accounts, including the well-known firm of Braunsteen-Blatt Co. at At-

TALKING MACHINE DEALERS

can greatly increase their profits without additional overhead expense, by selling the world-famous

Weymann "KEYSTONE STATE" Musical Instruments

a combination that has proved to be an instantaneous success.

Write for catalogue

H. A. WEYMANN & SON

Manufacturers

Victor
Wholesalers

1108 Chestnut St.
Philadelphia, Pa.

Established 1864

A Good Time To Lay In Your Supply of Accessories

Lundstrom Cabinets—One of the best selling propositions in the Talking Machine business today.

Record Cleaner Brushes—A neat plush brush, leather back—finds a ready sale.

Record Lites—A necessity for every talking machine with a lid. Makes a fine Christmas gift.

Needle Cutters—Lyon & Healy and the Record Lite Fibre Needle Cutters. Best cutters on the market.

His Master's Voice—A Plaster Paris Miniature. Four inches high. Sells like hot cakes. Order a sample dozen.

Penn Phonograph Co., Inc.

913 ARCH STREET

PHILADELPHIA

Victor Wholesalers Exclusively

Sell Wisely During November

THE shortage of goods dictates that every care should be used in your Credit Department to give preference, first, to cash customers; second, to charge customers; third, to customers paying large down-payments and terms, and fourth, to regular terms customers.

This policy will strengthen your financial position and put you in excellent shape to take care of the predicted new era for 1919.

Meanwhile, rest assured that every energy back of Buehn Service is being utilized for your progress.

The Louis Buehn Company, Philadelphia
Victor Wholesalers

lantic City, where they opened a very fine department, and are doing a whale of a business.

H. A. Weymann & Son Activity

H. A. Weymann & Son have reported a number of new dealers for their Keystone State line of musical instruments. This line is proving very valuable to numbers of Victor dealers throughout the country, as it is the means of adding additional profit, but is at the same time entirely non-conflicting to their regular line. The co-operation of the dealers in sending in their orders as far in advance as possible has enabled H. A. Weymann & Sons to make satisfactory distribution of these goods.

During the Fourth Liberty Loan the window of H. A. Weymann & Son on Chestnut street attracted much comment on its timeliness and

patriotism. Much attention is always given by this house to their window display. Favorable comment on the same is not alone limited to Philadelphia, but one of their recent displays was reproduced and commented upon in the "Voice of the Victor."

DIAMOND DISC PRICES ADVANCE

New Prices for Edison Re-Creations Which Go Into Force on November 15

In a general bulletin to its jobbers Thomas A. Edison, Inc., announces an advance in prices of its Diamond Disc re-creations. The advance is made effective November 15, 1918, and until further notice applying to all shipments made on that date and thereafter irrespective of when orders were placed. The following is a comparison of the present and future list prices on which its discount to jobbers is figured:

Class	List Present Prices	List Price Effective Nov. 15
No. 50001 and up.....	\$1.00	\$1.15
No. 80010 and up.....	1.50	1.70
No. 82031 and up.....	2.00	2.25
No. 82510 and up.....	2.50	2.75
No. 83004 and up.....	3.00	3.25
No. 84001 and up.....	4.00	4.25

In its bulletin Thomas A. Edison, Inc., lays stress upon the fact that these advances are the result of careful consideration and reflect the extreme of moderation. Referring to the forthcoming Federal excise taxes the bulletin says:

"At the moment we do not know what tax will be imposed on phonograph records by the pending Revenue bill, and accordingly cannot

include such tax in our increased prices. Furthermore, while recognizing the convenience of such action we are opposed to it as unfair to the ultimate consumer, and we believe the practice is one that is looked on with disfavor by various Governmental authorities.

"When the new Revenue bill becomes effective we shall bill the excise tax to jobbers as a separate charge."

Provisions also are made for an adequate return allowance to dealers to cover re-creation overstocks and the details of such re-creation returns are arranged as to simplify the procedure now in effect for the dealer and to save transportation.

ENLARGING SPACE FOR RECORDS

The C. F. Murray-Smith Co., of Wilkes-Barre, Pa., are finding their Amberol record trade expanding to such an extent that it has become necessary to use much of the space formerly devoted to the disc line, and to take additional space for the disc. The contemplated addition will make the department some fifty feet in length with two booths on each side and a disc and Amberola display in the center.

The Anthony Furniture Co., of Providence, R. I., has adopted the following slogan for its talking machine department: "The cosiest Victrola rooms in Providence."

The pessimist always hears the katydid announcing the coming of winter first.

The BEST TALKING MACHINE NEEDLE

On the Market—Packed in Counter Salesman



50 Needles to a box and they retail at 10c. per Box.
60 Boxes to a package \$6.00.
This package costs you \$3.90 net.
Your profit is \$2.10 and your customer gets a needle that will give satisfaction.

The Fred. Gretsch Mfg. Co. 60 Broadway Brooklyn, N.Y.
Manufacturers of Musical Instruments
Canadian Wholesale Agent, H. A. BEMISTER
10 Victoria St., Montreal, Can.

WESTERN VENEER PRODUCTS CO.
3900 CHOUTEAU AVENUE, ST. LOUIS, MO.

Largest Manufacturers of 3-ply Veneer Phonograph Shipping Cases

Ask for Prices and Samples



"Send for Catalog"

More sales are snared by that phrase than any other trick in the ad-man's bag. Are you featuring *your* new catalogs with your trade?

Columbia Graphophone Co.
NEW YORK

SAN FRANCISCO TRADE IS ACTIVE DESPITE CONDITIONS

Brighter Outlook Held for Business Now That Epidemic Is Conquered—Welcome for N. F. Milnor—New Machine Makes Its Debut—California Phonograph Co.'s New Quarters—Other News

SAN FRANCISCO, CAL., October 28.—Business has not been all that might have been desired here during the month of October, but sales are considered well up to expectations in view of the circumstances. During the first half of the month, or, to be more exact, during the period of the Fourth Liberty Loan campaign, the selling of talking machines, records, etc., took secondary place to the securing of bond subscriptions, and then the Spanish influenza came along, causing business generally to slump even more than it had under the pressure of the loan drive. All schools, theatres and other public meeting places were ordered closed, people were advised to avoid crowds, and when appearing away from home to wear masks, all of which has had a strong tendency to keep people off the street and out of the stores. From present indications the ban will soon be lifted, however, and then the music stores, as well as other lines of business, hope to make up for lost time.

New Columbia Manager Welcomed

The Western trade bade farewell to Fred A. Dennison as Pacific Coast manager of the Columbia Graphophone Co. during the past month, and welcomed his successor, Nathan F. Milnor, into their midst. Mr. Milnor has, as he puts it, just been getting acquainted thus far, and incidentally putting some finishing touches on the company's handsome new offices and salesrooms on the second floor of the Daylight Building in Sutter street. Lack of stock has a tendency to curb aggression, he says, in seeking new business.

George W. Lyle a Welcome Visitor

A welcome visitor to the local trade about the middle of October was George W. Lyle, general manager of the Pathé Frères Phonograph Co., while making a tour of the country. He had visited in southern California before reaching the Golden Gate City, and after spending a few days in this vicinity continued his travels to the Pacific Northwest. With the introduction of new capital into the Western Phonograph Co. and the incorporation of the business Mr. Lyle expects "big things" in this territory in

the way of increased business for the Pathé line. This company has the distributing agency for Pathé machines and records in the States of California, Arizona and Nevada, and is branching out in a very promising manner.

New Wholesale Quarters Opened

A new talking machine has just made its appearance in San Francisco. It is The Lois, offered by the United Talking Machine Co. R. F. Bowles is manager. He has opened an office and sample room at 417 Montgomery street, and from here will cover the territory west of Denver. In addition to The Lois line of talking machines Mr. Bowles has the Western distributing agency for Operaphone records, also a new line here. The two in his estimation make a very strong combination.

G. E. Morton Joins the Colors

Another San Francisco talking machine man has given heed to the call for men to serve the colors. G. E. Morton, manager of the Emporium talking machine department, is the man in question. He has made arrangements to enter the Artillery Officers' Training Camp at Camp Taylor, Ky., and expects to be called very shortly. Meanwhile he is continuing his regular duties, and a successor has not been named to take his place.

Larger Quarters for California Phonograph Co.

The California Phonograph Co., of which F. A. Levy is president and general manager, has fitted up extra space in the basement of its store on Market street, above Sixth, in order to take care of a larger reserve stock of records. Other facilities have been improved also, tending to keep pace with the growth of the business. Mr. Levy comments particularly on the big gain in the demand for records in the last few months, which he attributes largely to the increased interest in patriotic music. At present things are quiet, but Mr. Levy looks for normal selling to return as soon as the epidemic passes over.

Muratore Records Help Loan Drive

The Stern Talking Machine Co., according to Frederick Stern, has experienced a tremendous

call for the records of Lucien Muratore, since his appearance here during the Fourth Liberty Loan campaign. The attractive advertising done by the Pathé Co. has helped out wonderfully, he says. Mr. Stern is now anxiously awaiting a large shipment of Pathé records.

Now Comes the Lady Traveler

In keeping with the spirit of the times Walter S. Gray, jobber of talking machine trade accessories, has employed a lady traveler. She is Miss Hazel Layton, who has had quite a bit of experience in the retail end of the game, and is making a very good initial showing in booking wholesale orders. At present she is out on a Southern trip. To provide more office space and also more room for displaying his lines Mr. Gray has taken another office in the Chronicle Building, and is using his old quarters for showing bulky goods only.

Brunswick Line for Wiley B. Allen Co.

The Wiley B. Allen Co. has put in a stock of Brunswick phonographs and is conducting a strong campaign in their behalf, which George W. Hughes says is bringing very good results.

Kohler & Chase have again added talking machines, after confining their attention to pianos, players and sheet music for some time. The Pathé lines is featured.

PUBLICITY CAMPAIGN IN DALLAS

Music Dealers Combine in Advertising Drive in Which the Talking Machine is Featured

The Dallas Music Industries Association has been conducting a very active campaign in the daily newspapers of that live Texas city in which page ads have been used to splendid advantage. In this publicity the talking machine has come in for a large share of consideration, and one advertisement in particular shows the value of music in the workroom and factory, as well as in the home. It points out that talking machine music is a tonic and relaxation and eases the load and increases the pleasure of every human being—man, woman or child. The concerns jointly interested in this campaign are the Bush & Gerts Piano Co., Brooks Mays & Co., Field Lippman Piano Stores, W. A. Green Co., G. H. Jackson, Leyhe Piano Co., The Edison Shop, Sanger Bros., Thos. Goggan & Bros., Titcher-Goettinger Co., Will A. Watkin Co., Western Automatic Music Co., and the Adam Schaaf Piano Co.

A MUCH TRAVELED GRAFONOLA

CONCORD, N. H., November 5.—The Harriott Music Co., Columbia dealers here, recently made a sale of a Columbia Grafonola which Mr. Harriott believes will establish a record. The sale was made to a missionary who is stationed at Monteaba, Africa. The Grafonola will travel from Concord and New York to the West Indies, thence to Cape Town and Mombasa, thence inland 1700 miles, the greater part of this distance being covered by native porters. It is expected that the Grafonola will not reach its destination for nearly six months.

CRYSTAL EDGE MICA DIAPHRAGMS

M
I
C
A

Let us send you samples *today* of our diaphragms and you will readily understand why the best talking machines are equipped with *Crystal Edge Mica* diaphragms exclusively.

We use only the very finest selected mica, the best diaphragm material in the world.

PHONOGRAPH APPLIANCE CO., 109 West Broadway, NEW YORK



Otto Heineman Phonograph Supply Co.

INCORPORATED

25 WEST 45th STREET, NEW YORK

FACTORIES, ELYRIA, O.—NEWARK, N. J.
PUTNAM, CONN. SPRINGFIELD, MASS.



CHICAGO

ATLANTA

SEATTLE

TORONTO

MOTOR PERFECTION

The achievements and progress in phonograph motor manufacturing in recent years are emphasized in the latest designs of

HEINEMAN and MEISSELBACH MOTORS

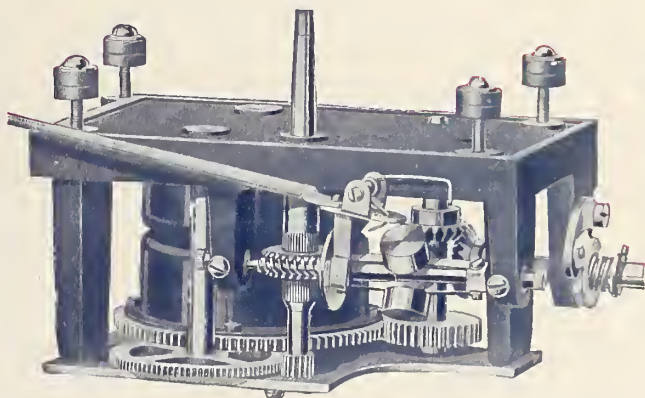

Heineman Motor No. 77

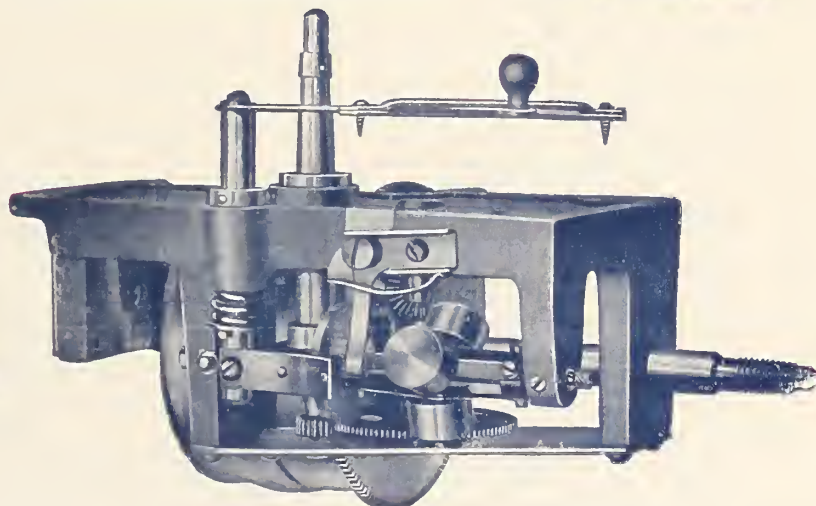

Meisselbach Motor No. 16

- Q** HEINEMAN and MEISSELBACH Motors are recognized the world over as the *best* horizontal and vertical spring motors that are produced.
- Q** They are offered to the trade with an iron-clad guarantee from the world's largest manufacturers of phonograph motors.

GIVE! GIVE!! GIVE!!!

The Boys are still "Over There" and will be for some time to come—they need the comfort the *United War Work* can provide.

Through sheer joy for the Peace that has come at last

GIVE! GIVE!! GIVE!!!

to the UNITED WAR WORK DRIVE—NOVEMBER 11-18th

Otto Heineman
President



MEISSELBACH



TONE ARMS

MOTORS

SOUND BOXES



FAVORABLE TRADE REPORTS FROM PITTSBURGH DISTRICT

Home Entertainment During Influenza Epidemic Helped Sales of Records—Standard Co. Booming "In Stock" Records—Rotary Club Donates Grafonolas—Many New Representatives Recorded

PITTSBURGH, PA., November 4.—The talking machine trade in this section has not apparently suffered to any great degree as a result of the Spanish influenza and the quarantines enforced by the health authorities in efforts to stamp out the disease. Due to the prohibition of public gatherings, and the closing of theatres and picture houses, the thoughts of many home people turn to entertainments within their own houses, and record sales jumped accordingly.

A. B. Smith, assistant manager of the Columbia Co. branch, stated that the sales of records for last month far exceeded similar sales for October, 1917. He said: "We are more than gratified with the sales of Columbia records. Our dealers have been very energetic in advertising and giving publicity to the records that were issued during October, and as a result sales have been far in excess of what we had anticipated." Mr. Smith also indicated that Grafonolas were moving satisfactorily.

At the Standard Talking Machine Co. offices it was learned that the company, through its service department, is making laudable efforts to bring to the attention of its clients the use of "In Stock" records. Very attractive posters, with lists of "In Stock" records, are printed. These posters are for the use of dealers and to be displayed in the shops or show window. By "In Stock" records are meant records that can be supplied at any time in reasonable quantities, and they include many excellent numbers. The Standard Co. has just added a new press and other equipment in its printing department.

A. N. Ansell, manager of the Victrola department of McCreery & Co., who returned a few days ago from a business trip to New York, is prepared for a brisk Christmas trade. The Victrola department under his direction is one of the largest in the city and the demonstration rooms are attractively fitted up. Owing to the war all of the male members of the sales force in the department have been called to the colors and their places have been taken by young women, who are proving very acceptable salespersons. Mr. Ansell reported excellent sales for October. On the last day of the month he sold two Victor machines, each priced at \$225, and an additional order of \$100 worth of Victor records for each within a half hour.

George S. Hards, manager of the Victrola department of the W. F. Frederick Co., and A. R. Meyer, manager of the Victrola department of the Joseph Horne Co., both active members of the Talking Machine Dealers' Association of Pittsburgh, were ill for some time during the past month, but are now back "on the job."

The Rotary Club of Pittsburgh in order to furnish music to the soldiers in the camps in this vicinity have thus far donated eight \$60 Grafonolas and a number of Columbia records. They were purchased through the S. Hamilton Co.'s talking machine department, which is under the direction of T. E. Shortell.

H. J. Brennan, manager of the Pittsburgh Pathé Shop, is very optimistic concerning the holiday business outlook in Pathé machines and Pathé records. He said: "We have made ample provision for providing for the demands of our retail dealers as well as the retail sales in our local branch. Our road men who have covered, within the past few days, territory in western Pennsylvania, eastern Ohio and West Virginia, have booked many orders for early Christmas delivery. We have just arranged for the opening of a new Pathé shop in Youngstown, O., where the Michigan Furniture Co. has been given the agency for Pathé machines and records."

The J. M. Hoffman Co., a leading music house, has taken the agency for the Brunswick phonograph. They also handle the Starr phonograph and Gennett records.

A. A. Buehn, manager of the Buehn Phonograph Co., Edison jobbers, reported very excel-

lent sales for October, and is anticipating a brisk holiday sale of Edison machines and records.

Gray & Martin, who handle the Sonora line, have very fine and spacious quarters in the Jenkins Arcade. Their demonstration rooms are attractively fitted up. Sales of the Sonora machines were said to be very satisfactory, and it was stated that all machines that could be shipped in time for Christmas delivery would be disposed of. The Household Furniture Co. also sell the Sonora machine, and last week had a fine display of the Sonora styles in their large show windows.

The Dauler-Close Furniture Co. for some time past have been conducting an advertising campaign on behalf of the Cheney phonograph with excellent results.

Miss Lillian A. Wood, in charge of the Victor educational department of the C. C. Mellor

Co., gave a very successful demonstration of the Victor methods in a pleasing talk and Victrola recital before the pupils and faculty of the Western Pennsylvania Institution of the Blind. The program included folk and Indian songs and was well received. Miss Grazella Puliver, of the Victor staff of educational supervisors, spent several days in Pittsburgh on professional work. She then left for Madison, Wis.

P. W. Simon, the well-known Victor dealer of Uniontown, Pa., was a recent Pittsburgh visitor.

S. H. Nichols, manager of the Columbia Phonograph Co.'s local office, is spending several weeks in Boston on business.

The Kaufmann & Baer Co., who have the local agency for the Aeolian-Vocalion, as well as the Vocalion records, have made a special announcement concerning Christmas buying of those instruments, advising that selections and purchases be made as soon as possible. At the present time the company has an excellent assortment of machines on hand.

J. A. Endres, sales manager in the Pittsburgh district for the Brunswick phonograph, reports a very brisk demand from the dealers.

The Phonograph You Will Eventually Handle

TO improve our models at the minimum cost we have decided to concentrate our efforts of production upon the marketing of but *T-W-O* popular-priced models. This we feel is the most advisable course in face of the difficult manufacturing conditions to-day.



Model I

Height 42 inches, Width 17 inches, Depth 19 inches.

Retail Price, \$70.00

Model Number II is similar to model Number I in construction differing in dimensions only, the same being: height 46½ inches—depth 21 inches—width 19 inches.

Retail Price, \$85.00

We positively believe that the fruits of our efforts are absolutely the best that can be produced for the money. We do not offer our product to the trade as a "bargain," but as greater value for the price than any other machine on the market. We invite the most careful and deliberate inspection and comparison.

Our stock is so complete at all times as to insure prompt and immediate shipments. However, transportation is so uncertain it is advisable to order as far in advance of your needs as possible to avoid delay and disappointment.

Distributors of Lyric Records
and Wall-Kane Steel Needles

Write Immediately for Unusual Liberal Discounts and Territory

ORDER YOUR SAMPLE NOW

OPEROLLO PHONOGRAPH COMPANY

54 W. Lafayette Blvd.

DETROIT, MICH.

NOT

Just Another
"Machine"



It's Not a
Machine
at All

It's a *Supreme Musical Instrument*

THE FULTON FONOGRAF

Artistically and Acoustically RIGHT

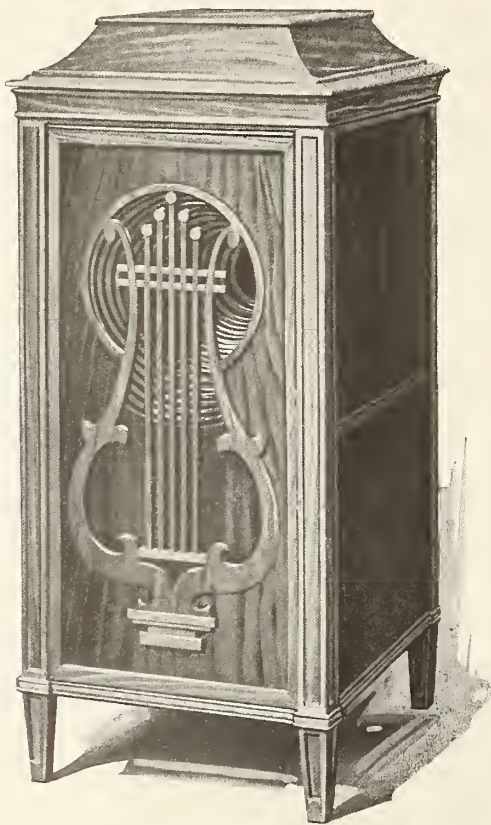

Style A Closed

There's our big absolutely exclusive feature, the **spun metal vibratory horn**. It gets a clear, resonant, soft, penetrating, beautiful tone and aids and abets *our own* exclusive, acoustically perfect, **thin model sound box** in accurately reproducing the voice or instrument of the recording artist.

The **motor**, made in *our own* plant, under the personal supervision of the inventor, is a mechanical wonder and never causes the slightest variation of pitch because of uneven operation.

The **Fulton Cover Support** is a delight. A touch raises the cover. It stops at any desired position, does not warp the lid and cannot fall, injuring sensitive fingers.

We make *our own* cases and they are models of artistic cabinet work.

In other words the **Fulton Fonograf** is made by us in its entirety. We stand behind it in every respect.

The **Fulton Fonograf** *looks* different and *is* different.

It's a natural leader and with it you cannot fail to capture the best trade and the best paying trade in your community.

Better write for full information today. Agencies are being established rapidly and you cannot afford to miss the one best bet in the talking machine field today.

FULTON-ALDEN COMPANY

Factory and General Offices, WAUKEGAN, ILL.

Chicago Warerooms : 305-309 E. Jackson Blvd.

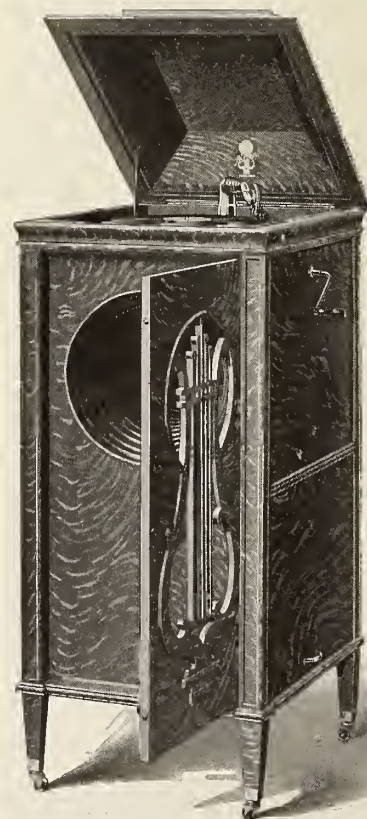

Style A Open

INFLUENZA EPIDEMIC DEMORALIZES CLEVELAND TRADE

Dealers Pleased at Better Outlook—Death of Henry N. Brainard—The Wamelink Sale—Talking Machine Dealers' Association to Meet Late This Month—Records for Soldiers—Other News

CLEVELAND, O., November 4.—Cleveland's talking machine dealers were hard hit during the last two weeks of October and the first few days of November because of the epidemic of influenza, which caused the health authorities to close retail stores at 5 p. m. daily, Saturday included.

The closing order kept thousands of people employed away from music and other stores. The short noon hour did not afford time for shopping. The early store closing Saturdays and other days barred these people from stores during work hours, so retailers of talking machines as well as concerns offering other lines of goods found themselves without patrons.

Talking machine dealers took the new turn of ill-events as a part of conditions.

The closing ban hit hard the slogan for early holiday shopping being sounded by all talking machine dealers, but the ban of the health moguls will probably be lifted in a week and members of the Talking Machine Dealers' Association of Northern Ohio say they will then get into the fight for early holiday orders with a vim.

The Brunswick-Balke-Collender Co.'s Huron road store reports a good run of business in its talking machines during October. "Business has been hard hit by the epidemic," said Manager W. F. Young, "but we are preparing for an unusually large holiday trade and are booking many orders for Christmas delivery."

Charles K. Bennett, president of the Talking Machine Dealers' Association of Northern Ohio, announces that the concert proposed by the organization has been postponed on account of the "flu" epidemic. The concert was originally scheduled for about the middle of November. No date has been set, although steps had been taken by a committee to make the concert an interesting one.

The epidemic also knocked out the October meeting of the association members. The November meeting has been fixed for the third Thursday at 6 p. m. Dealers are urged to attend to discuss ways and means of getting early holiday trade.

The Conrad-Baisch-Krohle Co., Euclid avenue furniture dealers, are using talking machines as trade attractions. The firm's present window

display of machines and records is almost equal to that of any talking machine dealer in the city.

"We find these machines excellent trade producers," said a member of the firm, "and our sales of machines are constantly increasing. Often in fitting out homes we include a talking machine and several records. Machines are now regarded by many persons as household furnishings, and newly weds accept this new condition and buy accordingly."

H. L. Garford, the head of the Garford Mfg. Co., makers of talking machines, in Elyria, O., has given most of his time to the district draft board in Cleveland during the past year. Mr. Garford's financial sacrifice has been heavy, but he has entered no complaint. His usual midwinter trips to his Pacific Coast home have been cut out for two winters and he is still on the job at the old court house, this city, almost daily. Few Ohio men of his means have been more self-sacrificing in the cause of winning the war.

The Harmony Music Shoppe Co., which recently took over the piano, player-piano and talking machine business of the Hart Piano Co., has added a novel and attractive show window booth to the "shoppe" in the Arcade. President W. S. Raeder, of the company, reports good business and an expansion of the talking machine features of his business.

Because "music is a war weapon" Mayor Harry L. Davis has named a committee consisting of James A. Taylor, Joe Folkman, William H. Krippendorf, Charles Henderson and John A. Doan to take steps to collect as many talking machines and records as possible to be sent to training camps for soldiers. This action was taken in response to the national movement to provide more music for soldiers and others engaged in war activities. Talking machine dealers of the city have promised their co-operation in this new movement.

Henry M. Brainard, seventy-four, for over fifty years the head of the Brainard Sons Co. music store, died October 27. The store was founded by his father, Silas Brainard, one of the city's pioneers. The store was well patronized.

The Collister & Sayle Co., Victor retailers, staged one of the best Hallowe'en window decorations of the city. The night, however, was not observed on account of the epidemic, which caused a cessation of all public meetings in the city.

"Let this Christmas be one of good music and good cheer" is the message the music department of the May Co. is sending to patrons this year. Manager Dan J. Nolan, of the company's big music department, is pushing the early sale of talking machines, records, player-pianos and other musical instruments. He reports an unusually large number of early bookings for Christmas delivery.

The purchase recently of the entire stock of the J. T. Wamelink & Sons Piano Co. by the Starr Piano Co. caused the passing of a music house established by J. T. Wamelink in 1835. The Huron road store of the Wamelink house was also taken over by the Starr Co., whose district manager is E. G. Taylor, who came to Cleveland twelve years ago from Johnstown, Pa. He now has charge of four stores in Cleveland, the main house, in Huron road, that of the Wamelink concern, a new branch in Prospect avenue, and another at Woodland and East Fifty-fifth street, besides stores in Elyria, Akron and elsewhere in northern Ohio. Eugene Wamelink has gone with the Starr people. The stock includes a large number of talking machines, records and other instruments which are being disposed of at special sales.

Buescher's store is pushing Victrola war records through local advertising and otherwise getting a fair share of business.

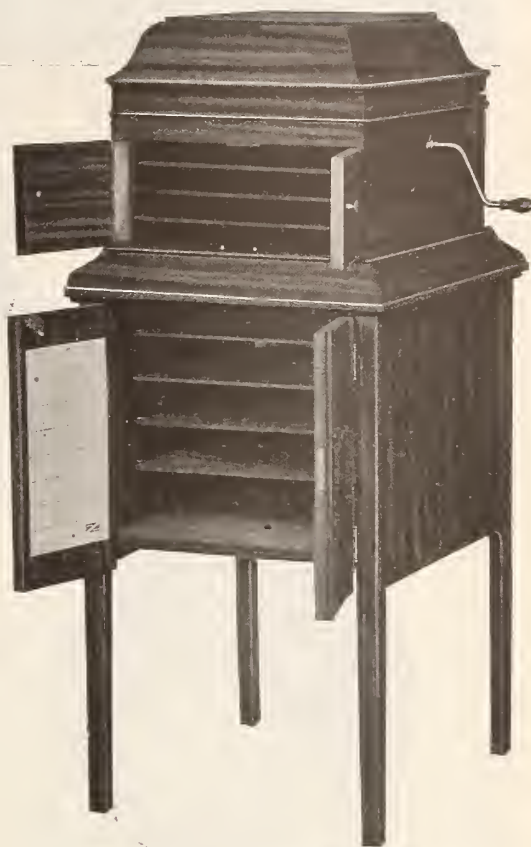

No. 1410 Rim Table for Victrola IX or IXA Mahogany Holds 5 Victor Albums

INCREASE RECORD SALES WITH UDELL CABINETS

AN attractive, solidly built, efficiently fitted cabinet encourages machine owners to buy more and better records, and protects those records. It doubles the practical value of the machine.

It takes little salesmanship to convince a customer of the facts and every cabinet sale means a two way profit on the cabinet itself and on the new records sold.

Make UDELL Cabinets keep up your profit average.

A catalog—free on request—will help you decide.



TRADE MARK

THE UDELL WORKS
1205 W. 28th Street
INDIANAPOLIS INDIANA

"The Music Without the Blur!"

This ideal of talking machine manufacture is attained more nearly than by any other, in the construction of the

MARVELOUS MAGNOLA "Built by Tone Specialists"

"Magnola's Tone Deflector eliminates the scratch"



Watching the Music Come Out

We want to show you how to make money with MAGNOLA; and how MAGNOLA is the best buy on the Talking Machine Market to-day.

Send us your name and let us send you some real Talker Tips.

MAGNOLA TALKING MACHINE COMPANY

OTTO SCHULZ, President

General Offices 711 MILWAUKEE AVENUE CHICAGO
Southern Wholesale Branch 1530 CANDLER BLDG. ATLANTA, GA.



"The Quality Phonograph"



An Enlargement of the Pathé Sapphire Ball and Pathé Record Grooves

The best selling point is better than ever today!

EVER since its origin, the Pathe Sapphire Ball has been the best phonograph selling point for the dealer. Because it is *exclusive*, permanent—does away with needle changing altogether—produces pure natural tone and gives long life to records.

Today, with needles rising in price by the minute and rapidly disappearing from the market, this big exclusive Pathe feature is not alone a better selling point than ever before. It insures the dealers against a possible future stoppage of his phonograph sales.

Right now, when we can assure you immediate and full deliveries of Pathe Phonographs, get in your orders.

Do you know what "The Other 20%" is? Write for book "The Other 20%" and it will tell you plainly and convincingly.

No Needles to Change

The Pathé Sapphire Ball takes the place of needles. It need not be changed.

Long Life to Records

(Pathé Guarantee)

We guarantee every Pathé Record to play at least *one thousand times* with the Pathé Sapphire Ball, without impairment to the unexcelled beauty of tone and without showing any perceptible wear on the record.

The Pathé Controla

With the Pathé Controla you may increase or decrease the tonal volume of the Pathé Phonograph at will.

Plays All Records

Each Pathé Phonograph plays not only Pathé Records, but all other makes of records, and plays them perfectly.

Pathé Frères Phonograph Company

20 Grand Avenue

Brooklyn, N. Y.

The Pathé Frères Phonograph Co. of Canada, Ltd., Toronto

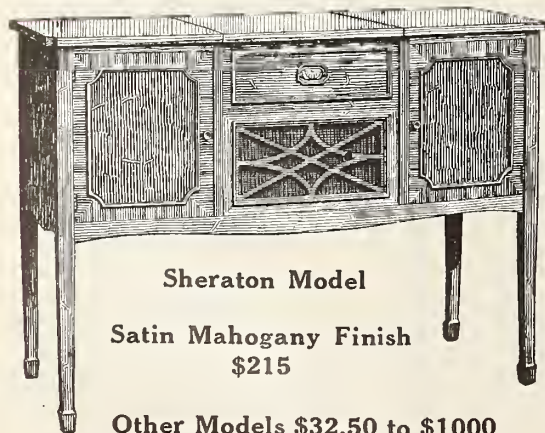

Sheraton Model

Satin Mahogany Finish
\$215

Other Models \$32.50 to \$1000



MURATORE

Principal Tenor
Chicago Opera Company

Pathé



Records

At Least one thousand times

“What! *Guaranteed* Records?”

Well, that certainly means “easier to sell” Records, doesn't it?

Especially when—

It further means the latest American music before out on other records and a complete selection of the “old world's” music never out on other records.



ALL MURATORE'S
Records are Pathe Records

Read the Pathé Guarantee :

“We guarantee every Pathe Record to play at least *one thousand times* with the Pathe Sapphire Ball, without impairment to the unexcelled beauty of tone and without showing any perceptible wear on the record.”

And don't miss any more of the sales this Guarantee alone makes for the dealer. Write for Pathé Dealer's proposition today!

Pathé Frères Phonograph Company

20 Grand Avenue

Brooklyn, N. Y.

The Pathé Frères Phonograph Co. of Canada, Ltd., Toronto



An Enlargement of the **Pathé Sapphire Ball** and Pathé Record Grooves

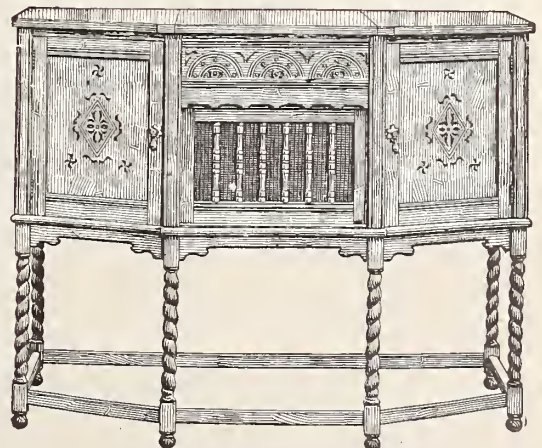

Jacobean Model

SUBSCRIBE \$6,632,550 TO FOURTH LIBERTY LOAN

Talking Machine Industry Helps New York's Allied Music Division Go Over the Top by 50 Per Cent.—How Talking Machine Men Worked to Roll Up the Tremendous Total

Music again came to the forefront in New York and vicinity during the recent drive for the Fourth Liberty Loan, when the Allied Music Division, in which the talking machine industry was strongly represented, went "over the top" with a total of \$6,632,550, more than 50 per cent. over the quota of \$4,350,000 set for the division.

Inasmuch as all divisions of the music trade and profession combined in rolling up the record for Allied Music, it was not regarded as a matter of policy to announce the subscriptions from any one section and thereby provide opportunities for comparison, but it can be said that the talking machine industry, which subscribed something like \$1,000,000 to the Third Liberty Loan, observed strictly the injunction to double up the Third Loan subscription for the Fourth Loan, and then went a little bit further. There is at least one subscription of \$500,000, and another for \$400,000 from talking machine companies that were credited to the Allied Division, and subscriptions of \$100,000 or \$200,000 were surprisingly plentiful, despite the fact that war with its consequent effect upon production has been a severe strain on the finances of the trade.

To single out any of those working on committees who garnered the talking machine men's subscriptions and who were most largely responsible for the result would prove a somewhat difficult task because everyone put forth a maximum of effort for the common end. Although Mark P. Campbell was chairman of the Allied Music Division, J. Newcomb Blackman was vice-chairman of the division, and in direct charge of the campaign in the talking machine trade, those assisting him being H. L. Willson, who looked after the subscriptions for the manufacturers; Roy J. Keith, who had charge of the jobbers and wholesalers' section; Edward L. Boykin, who was responsible for the

MICA

NO STAINS IN OUR
DIAPHRAGMS OF BEAUTY
THE INTERNATIONAL MICA COMPANY
Factory, 37th and Brandywine Streets Office and Sales Department, 1228 Filbert Street
PHILADELPHIA

subscriptions of the dealers, and C. G. Child, through whose efforts Galli-Curci, Caruso, McCormack and Heifetz were secured for the great rally at Carnegie Hall on September 29, the details of which were given in *The World* last month.

As vice-chairman of the entire division Mr. Blackman had a big job on his hands, and realizing the fact thoroughly, simply forgot his regular business for the three weeks' period and gave all his thoughts and energies to helping Uncle Sam. In the talking machine trade proper the sub-chairmen and captains also forgot business for the nonce, and enlisted their selling abilities in the cause of the loan, with results that speak for themselves.

ORGANIZATION IS MOST TIMELY

President Reis, of the Tri-State Victor Dealers' Association, Speaks of Postponement of Their Regular Meeting and Also Why Dealers Should Get Together and Work Together

St. LOUIS, Mo., November 3.—The Tri-State Victor Dealers' Association, announced to meet in this city October 23, was a victim of the influenza quarantine. President Val Reis and Secretary J. F. Ditzell have announced that the meeting will be held later, probably some time during November, and that they will make every effort to arrange a more elaborate program than they had in mind for the October meeting.

This greater program idea is partially due to the fact that for the October meeting the Caruso concert was a strong attraction. This was to have taken place on the evening of October 22, and the officers of the association believed that every Victor dealer would be greatly interested in this concert and would come a day ahead to hear Caruso, who has done so much for their record list. But the Caruso concert has gone

over to April or May, because of opera engagements, so it cannot well figure in the Tri-State annual meeting.

"We must hold this meeting as soon as possible," said President Reis, "or the members will begin to think that this is sort of a private association for the benefit of the St. Louisans who happen to be officers. Nothing is further from our minds. We want every dealer interested and helping to solve the many problems that confront every Victor dealer, as well as other talking machine dealers. We feel that it is up to the Victor dealers to take the first step in this line, as they always have been the leaders in the trade and should maintain that position.

"Further than that, we believe that this is the proper time to cement organizations. Just now the trade is on a higher plane as to credits, cash payments, abolition of free service and freedom from other evils than ever before, and we feel that if we can get all the members together now, we can take important steps toward holding dealers of the country in line when machines become more plentiful, and the old evils are again likely to arise in the trade.

"I have been thinking much of late about these things, and it appears to me that the musical instrument trade is making a serious mistake at present by not taking up the matter of local organizations now while practically everybody is falling in line with the best ideas of credits and limit of free service. Now, while all hands can agree, would be the time to talk it over and get together and there would be a much better opportunity of keeping these agreements. All dealers now know the advantage of having business done in a businesslike way, and it is not hard to bring them together on almost any reasonable proposition.

"Here in St. Louis I happen to know that the man who formerly was the freest with credit now is getting even higher payments than some of his competitors. He boasts now of this. It would be much easier to get them all in line now and after they get in practice while there are no temptations they might stick indefinitely."

"I have been thinking much of late about these things, and it appears to me that the musical instrument trade is making a serious mistake at present by not taking up the matter of local organizations now while practically everybody is falling in line with the best ideas of credits and limit of free service. Now, while all hands can agree, would be the time to talk it over and get together and there would be a much better opportunity of keeping these agreements. All dealers now know the advantage of having business done in a businesslike way, and it is not hard to bring them together on almost any reasonable proposition.

"Here in St. Louis I happen to know that the man who formerly was the freest with credit now is getting even higher payments than some of his competitors. He boasts now of this. It would be much easier to get them all in line now and after they get in practice while there are no temptations they might stick indefinitely."

TALKING MACHINE MAN MURDERED

D. P. Proodian, who has conducted for the past five years a thriving business in talking machines at 158 North Main street, Providence, R. I., was recently murdered in his store by a man who attempted robbery. The assailant has been captured and will face a murder charge.

M. Welte & Sons, Inc., who a short time ago took on the Cheney talking machine in their studios on Fifth avenue at Fifty-third street, report much success with the line. The tone value and attractive cabinet designs of these talking machines provide a fitting side line for the particularly high-grade line of pianos and autograph pianos produced by this company.

The Wide Awake Phonograph Dealer

Knowing that the diverting of raw materials by the government for war purposes has curtailed the output of all Phonograph Manufacturers, is concentrating his effort on other sources of revenue than the selling of new Phonographs.

He is Increasing His Record Sales

The "BLISS" Reproducer, with its treated silk diaphragm, affords an incomparable aid to the dealer in selling Phonograph records.

The "BLISS" Reproducer eliminates that unnatural sharpness of mica—it reproduces with better articulation, tone quality, and volume.

Phonograph owners who have become tired of the unnatural reproduction of their phonograph records would again become enthusiastic purchasers if the merits of the "BLISS" Reproducer were brought to their attention.

Every standard make of Phonograph can be improved if fitted with a "BLISS" Reproducer.

Other Phonograph Specialties that we are featuring are the "Disk-Lite," an electric lighting attachment adaptable to any phonograph, and the "Phono-Lite," an automatic lighting attachment for the New Edison; also Diamond and Sapphire Points, Pathé Sapphire Points, Lakeside Rotometers, Johnson Electric Motors, B & H Fibre Needles, B & H Fibre Needle Repointers, and the Vallorbes Semi-Permanent Needles.

Write for our dealers' price list,—or
may our Parcel Post Salesman call?

WILSON-LAIRD PHONOGRAPH CO., Inc.
29 West 34th Street NEW YORK CITY

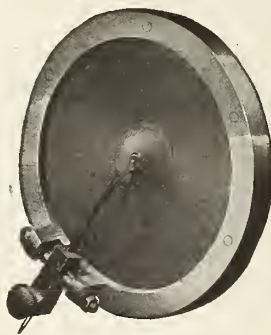



UNICO

Designs and Construction
Patented

SYSTEM

THE SALES BUILDER

Unico Demonstrating Rooms
Excel from Every
Standpoint

- DESIGN** Six standard styles
Special period styles
- CONSTRUCTION** Patented, Interlocking
Portable Units
Sound Insulated
- FINISH** All standard Oak,
Mahogany and Enamels
- EFFICIENCY** Increased sales at lower
cost per sale
- ECONOMY** Moderate first cost
Always an Asset
Adaptable any location
- DELIVERY** Prompt shipments from
stock ready for imme-
diate use



Unico Racks and Counters
Maximum Capacity
Minimum Space

- DESIGN** Patented to correspond
with Unico Rooms
- CONSTRUCTION** Sectional Units adapta-
ble to any space
- FINISH** All standard Oak, Ma-
hogany and Enamels
- EFFICIENCY** All records always
available instantly
- ECONOMY** Moderate Equipment
Cost
Lower Operating Cost
- DELIVERY** Prompt shipments from
stock in all finishes

Install a
Complete Unico Department

- UNICO** DEMONSTRATING ROOMS
- RECORD RACKS
- RECORD COUNTERS
- CEILING DECORATIONS
- ARCH TREATMENTS

The Unico System has
Increased Sales and Profits
for almost 1000 dealers



Send to-day dimensions of your available space. Plans and
estimates for a complete department will reach you promptly

THE UNIT CONSTRUCTION COMPANY

RAYBURN CLARK SMITH, President

Fifty-eighth Street and Grays Avenue, PHILADELPHIA, U. S. A.

A STRIKING COLUMBIA WINDOW DISPLAY FOR DECEMBER

The dealer service department of the Columbia Graphophone Co. has prepared a December window display which will amply fulfil dealers' Christmas requirements this year. With a Grafonola or two, and a set of brilliantly lithographed cards and cut-outs, a complete holiday offering is covered, and the dealer's store front rendered an attractive spot which reflects the Christmas spirit and makes the passer-by realize

window, comprise this set. The large window streamer worded, "Which Grafonola Will You Buy," may be affixed to the glass slightly above the eye, while the "Dance Hits" and "Song Hits" cards will balance it on either side, also pasted to the glass. The two half-sheet cards, "Songs of Yuletide" and "Barrientos and Lazaro Duet," can be placed at either side of the window as shown, while the four smaller cards and five



A Holiday Window Prepared by the Dealer Service Department of the Columbia Co.

what is the most seasonable of gifts. The central figure in the window is the Columbia magazine ad for December, which points out to the public that the dealer's store is the market place for the extensively advertised Grafonola. Here an opportunity is afforded the dealer of becoming an active part of the vast publicity campaign, and cash in on the big expenditure of the Columbia Co. in newspaper and magazine mediums.

The display is technically described as follows: Fifteen cards and cut-outs, all equipped with easels and ready to be exhibited in the

record cut-outs may be artistically arranged in the foreground.

Five record display holders, each listing one of the new Columbia December records and illustrated by means of a flap attached, offer a novelty which is pleasing to the eye and quite unusual. In connection with these holders the Columbia metal window display records may be used to excellent advantage, and the commercial product spared from damage by the sun, which is liable to occur at this season of the year, when awnings are not used.

A popular E series record has been allotted

ILSLEY'S GRAPHITE PHONO SPRING LUBRICANT

—Ilsley's Lubricant makes the Motor make good
Is prepared in the proper consistency, will not run out, dry up, or become sticky or rancid. Remains in its original form indefinitely.
Put up in 1, 5, 10, 25 and 50-pound cans for dealers.

This lubricant is also put up in 4-ounce cans to retail at 25 cents each under the trade name of

EUREKA NOISELESS TALKING MACHINE LUBRICANT

Write for special proposition to jobbers.

ILSLEY-DOUBLEDAY & CO., 229-231 Front St., New York

a cut-out for a prominent place in the display. "The Gold and Silver Waltz," combined with "While I Am Crying for You," by the Gypsy Orchestra, is a record of great interest, and its prominence in the window display material is an indication of how the public is receiving this new form of music which bids fair to rival the Hawaiian craze of a few years ago.

The Columbia monthly window display service will be continued through the year 1919 along even more elaborate lines.

PROPOSED FLOOR TAX CONDEMNED

Executive Committee of Talking Machine Men, Inc., Passes Resolution Protesting Against Floor Tax Clause in New War Revenue Bill

A meeting of the executive committee of the Talking Machine Men, Inc., was held on October 25, 1918, at the office of the president, James T. Coughlin, 487 Eighth avenue, New York City. A motion was made and seconded that a resolution in regard to the new floor tax be adopted, which read as follows:

"Whereas, The new floor tax, Sections 909-910, as now contemplated is unfair, unjust and detrimental to the interest of our members and that the legal committee be instructed to continue their efforts with the Senate Finance Committee in order to have this new impost eliminated; inasmuch as a tax has already been paid on the goods; further

"The proposed tax would work a grievous injustice on nearly every talking machine dealer, who in order to do business must of necessity carry a complete catalog of records, many of which are slow sellers and almost dead stock; furthermore for the reason that

"The trade is at present laboring under severe difficulties occasioned by reduced discounts and a serious shortage of stock. This association, however, favors a tax which can be collected at the factory or source of supply."

The executive committee also recommended that the association apply for membership in the Music Industries Chamber of Commerce.

The session of the association was a short but highly important one.

AMERICAN



No. 22



No. 5

The AMERICAN gives satisfaction, and stays sold when delivered. We are able to supply our dealers for some months to come. The name, the design and the grade of merchandise are important factors, and a line of six models in two woods demands your attention. The AMERICANS go entirely on their merits.

American
Phonograph Co.

39 Fountain Street
GRAND RAPIDS MICH.



No. 8



No. 9



No. 10



No. 11



Otto Heineman Phonograph Supply Co.

INCORPORATED

25 WEST 45th STREET, NEW YORK

FACTORIES, ELYRIA, O.—NEWARK, N. J.—PUTNAM, CONN.

CHICAGO

ATLANTA

SEATTLE

CINCINNATI

TORONTO



OKEH RECORDS

Music on both sides.
Sapphire or steel needle.
Popular and standard selections.

Full particulars regarding the distribution of this record will be given to any dealer or jobber upon application.

SUPPLY
THE DEMAND

For
Latest
Broadway
Hits
85c.
In Canada
90c.



SUPPLY
THE DEMAND

With
The
Record
of
Quality
Hill-and-Dale
Cut

IMMEDIATE DELIVERY OF THE BIG SELLERS

Your customers are asking for Smiles, Belgian Rose, and other big Broadway hits.

Can you supply the demand? Turning customers away does not help build up your business. Handle OKEH Records, and give your customers what they ask for, when they ask for it.

The American public wants what it wants when it wants it.

O K E H



R E C O R D S

The Record of Quality

JOBBER
DEALERS

OKEH RECORDS are of special interest to you.

A remarkable proposition.

Get in touch with us today.

LET YOUR EAR BE YOUR JUDGE

OTTO HEINEMAN PHONOGRAPH SUPPLY CO., Inc.
25 West 45th Street, New York.

Gentlemen:-

I am interested in your OKEH RECORDS

Please put me on your mailing list.

Name.....
DEALER OR JOBBER

Street.....

City..... State.....

Featuring the Musical Possibilities of the Talking Machine

By William Braid White

[Note.—This is the twenty-first in a series of articles on the general subject of the musical possibilities of the talking machine. The aim of the series is to develop these possibilities from all angles, thus opening up fields for sales expansion oftentimes neglected wholly or in part.—Editor.]

MUSIC STUDENTS AS PROSPECTS

We may resist the truth as much as we will, but we cannot stay its progress. We may pretend to ourselves that the next few years will be as past years have been, that the world will wake from its dream of torture to go back to old ways and ideals without a spasm of change, but we know when we say it that we are talking nonsense. The world can never go back, and it would be a most unfortunate thing for the world indeed if it could.

Business

Now, among other things, which will never be again as once they were, is undoubtedly the business of selling musical instruments, especially those elaborate and relatively expensive embodiments known as the talking machine, the piano and the player-piano. The talking machine or phonograph, whatever one calls it, is at the moment passing through a very grave and very important crisis in its adventurous career. The days of promotion are decidedly past. The days of public indifference are gone for good. The days of blind acceptance are gone, too. In a word, the formative period has been left behind and we find ourselves facing a public grown strangely critical yet strangely desirous. We find before us a demand for music such as the world has never known before, and along with it a critical taste and judgment, which, with all it must yet learn before it is approved perfect, is nevertheless daily becoming more acute and exacting.

New Ideas

Such notices as that of the new reproducer which the Pathé people have just announced, such improving, refining and developing as we see all round us indicated in the advertising columns of this paper, point alike to the opening of a new and splendid era. They point also to a recognition by the trade of the need for higher and more critical standards, to support and meet the needs of a more exigent public.

It is evident indeed that we have much to learn. We are faced with the necessity for bringing before the public a more convincing story. We must have a new tale to tell and one which shall charm minds no longer fascinated by any sort of sounds ground out from any sort of machine. We have to find new and better retail methods, and find them now.

An Objection

But is it not true, some one will say, that the great difficulty just now is to get the goods? Is there the slightest difficulty in selling such machines and records as we can get? Assuredly not. There is no difficulty to-day, but things may be quite different to-morrow. However long the last stretch of the road to victory may be, the end is actually now calculable. Victory is coming. And with victory will come the manifold problems of demobilization, of reconstruction and of readaptation to ways of peace. It will therefore be more than ordinarily necessary for us to have in preparation for these times new and better machines, new and better records, new and better methods of selling.

A New Field

Much could be said on this subject that belongs better to articles on salesmanship, but there is one special point to which I should like to direct attention. When you come to think of it, the musical possibilities of the talking machine should always furnish the basis for any selling scheme whatever. Already the far-sighted and enterprising work of the Victor Co., to take one prominent example, has brought the message of the talking machine's musical

values to the attention of the people through the schools, those gardens of our social relations, and it now remains for us to carry on this work in even more intensive ways. Among the many possibilities which have not as yet been cultivated to any extent, but which are worthy of the closest investigation nevertheless, is that of linking up the talking machine with the definite and serious study of music. As yet, indeed, the details are not completely clear in my own mind, but I do not speak at random. The subject has been before the attention of musicians and of practical talking machine men and has the utmost importance and value.

For the moment it is possible only to lay down certain general ideas, from which perhaps may be evolved later more specific rules. But if the general principle can be established there will be no trouble about working out the details in due course.

For the Student

The point I should wish to press to the utmost is that the talking machine can be promoted, advertised and sold as a definite aid to the definite and serious study of music; an aid which is quite unique and which stands quite by itself, neither taking the place of any other method or implement or susceptible of supersession by any other. The assertion is also made here that by taking up and working out this idea in practical form, the retailing of the talking machine may be put into a stronger position for the strenuous times which we shall have to expect during the post-victory period. It is not, and is not asserted to be, the only new idea needed, but it is asserted to be one of the good and practical ideas needed by the trade.

Consider a few broad aspects of the question. We have all the elements and nothing is lacking save their due correlation. The study of music may be considered under two aspects, as professional work and as work in appreciation. Nine persons in every ten will be more interested in the second branch of the subject. But the tenth person will, of course, be the more serious one relatively and keenly interested. What can the talking machine give to the serious student of music?

The Question of Style

Whether the subject of study be voice, vio-

lin, 'cello or piano, the talking machine can always give one thing in unlimited quantity. It can give an unlimited number of examples of style. To the vocal student the opportunities for comparison of styles, of delivery, of phrasing and of general artistic conception are very numerous indeed, and become more numerous every month. Almost any branch of vocal study and vocal art can now be subjected, through the talking machine and its records, to close comparative study. It is literally as if one had the opportunity to take lessons in the art of singing from a whole regiment of the best singers.

The Student as a Sales Field

It seems to me that this side of the question has not yet been handled with sufficient intensity. The general public have heard much about having Caruso at home and all that sort of thing, all of which has been good and useful in its way. But the music student has not yet been made the object of definite sales work designed to bring him or her into close vital contact with the talking machine as with an improved weapon for his study and improvement. It seems to me that we are neglecting the enormous number of music students and their teachers.

What is true of the vocal student is also true of the violinist or 'cellist. The recording of the 'cello is one of the triumphs of the art and the same may be said to-day of violin records, which are now more than ever true to life and faithful representation of the loveliest musical instrument of all. More and more, the art of recording begins to approach complete fidelity. More and more, therefore, it is up to us to take advantage of every situation and of every strong point that is brought forward. These strong points multiply as the records and the machines improve and as the list of great artists becomes ever greater in size and importance. We are missing great opportunities if we fail to seek out, develop and enlarge every field of sales opened up as new fields always will be opened up with every improvement in manufacture. One of these opportunities is sketched out here. I shall hope to set it forth in complete detail during some subsequent articles in this paper.

7th Floor

229 Fulton Street

Clifford A. Wolf

MANUFACTURER OF

Diamond and Sapphire
Phonograph Points

New York City

Phone, 1678 Cortlandt

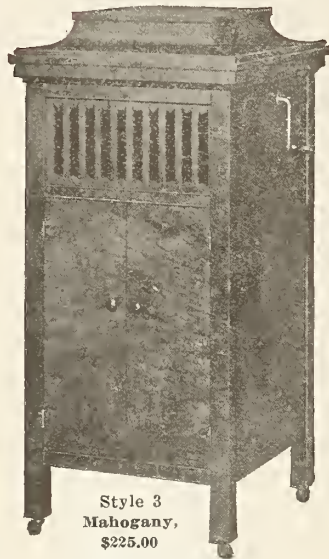

Style 3
Mahogany,
\$225.00

Walnut, \$245.00
Height, 51 inches.
Depth, 25 3/4 inches.
Width, 24 inches.

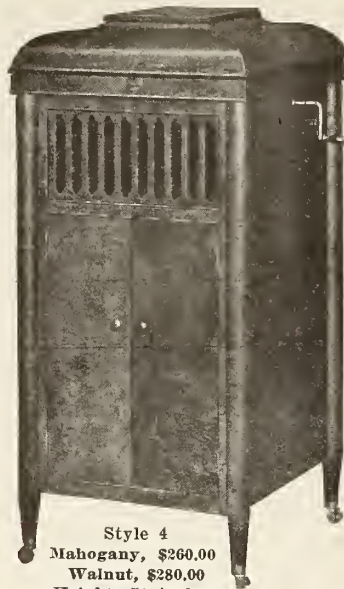

Style 4
Mahogany, \$260.00
Walnut, \$280.00
Height, 51 inches.
Depth, 25 3/4 inches.
Width, 24 inches.



Style 2
Mahogany,
\$155.00
Walnut, \$170.00
Height, 46 3/4 inches.
Depth, 24 inches.
Width, 21 3/4 inches.

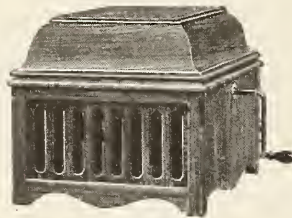

Style 00
Retail at \$60.00
Mahogany or Oak



Style 1
Oak, \$130.00
Walnut,
\$145.00
Mahogany, \$130.00
Height, 46 1/2 inches. Depth,
21 1/2 inches. Width,
19 1/2 inches.

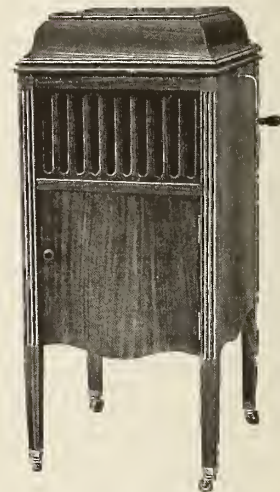

Style 0
Mahogany, \$95.00
Oak, \$95.00

THE BUSH & LANE PHONOGRAPH

BUILT by men who have made a life-study of tone-production, the Bush & Lane Phonograph combines the principles of the piano's sound-board with the highest ideal of case architecture and of constructional workmanship. It is an instrument of **UNIQUE**, not of ordinary or usual, good qualities. It stands in a class by itself; for it is among **PHONOGRAPHS** what its famous **NAMESAKE** is among **PIANOS**.

For prices, and *pertinent compelling facts*, get in touch with

BUSH & LANE PIANO COMPANY

HOLLAND, MICHIGAN

AN IMPORTANT U. S. COURT DECISION ON PRICE FIXING

In Dismissing Federal Indictment Against Colgate & Co., Charged With Violating Sherman Law, U. S. Circuit Court Expresses Valuable Opinions on Price Maintenance

The members of the talking machine trade who are involved in, or who have some direct interest in, cases now in the courts regarding the rights of a manufacturer to fix retail prices, as well as to refuse to sell to dealers who fail to maintain prices, have received with considerable satisfaction the announcement that Federal Judge Waddill, in the United States Circuit Court for the Eastern District of Virginia, sitting in Norfolk, Va., on October 29, dismissed an indictment returned against Colgate & Co., the soap and toilet powder manufacturers, for alleged violation of the Sherman Law. This action was on a demurrer by the company, which the Court sustained.

Judge Waddill sustained the contention of Colgate & Co. that a manufacturer, provided he is not in conspiracy with other manufacturers of similar products, has the right to fix and enforce the maintenance of reasonable and fair prices and that such a manufacturer is violating no law in refusing to sell again to a retailer who fails to maintain such a fixed price.

Price cutting demoralizes business, the Court declared, and the public is not always benefited by temporary reductions in prices if the article is not a necessity and if no monopoly exists in its manufacture.

It is expected that the action of Judge Waddill will have a material effect upon other cases of a similar nature now in the courts.

In analyzing the decision, Charles Wesley Dunn and Mason Trowbridge, of counsel for Colgate & Co., first referred to the fact that after the courts had pronounced illegal the old system of price maintenance contract between manufacturers and distributors, the manufacturers were forced to adopt other means, one of the plans being to attach a notice to a copyrighted book or patented article prescribing the price at which it could be resold, another plan being to license the use of the article by the dealer and by his customers as well. Authority to adopt both of these plans is held to be vested in the manufacturer under the Patent Law, but both methods were held to be illegal by the courts and therefore had to be abandoned, the most famous case under the licensing method being that of the Victor Talking Machine Co., with which the trade is familiar.

After reviewing the failure of various attempts to fix resale prices, the Colgate & Co. counsel said in part:

"This left but one remedy to a manufacturer still unforbidden by the courts. He might simply refuse to sell to any dealer who would not charge the prices the manufacturer suggested. Various concerns had adopted this policy, but probably none of them had employed it so long as Colgate & Co. or had stuck to it so consistently. This company maintained it continuously in some of its lines for forty years or more. The policy has become so far identified with them as to be very generally known in the trade as the 'Colgate plan.'

"In 1917 Federal District courts—in three cases between private litigants in which they passed upon this sales plan as used by other companies—instructed juries that this, too, created a combination in restraint of trade, and was contrary to the Sherman act. Thereupon the Attorney General informed Colgate & Co. that they would be indicted if they did not abandon the policy. It was not an agreeable thing to invite a criminal prosecution, especially in the face of these adverse rulings, but the company felt that they were fighting for a principle and that it was due to themselves and their customers to see the thing through.

"They stood for the fundamental right of all owners of property to sell or not as they please. The right of a dealer to resell Colgate products which he had bought and paid for, at any price he saw fit, was recognized fully by the company. But it claimed for itself a similar right with respect to goods it had not yet parted with;

the right to dispose of them as it saw fit, or, if it chose, not to dispose of them at all to merchants whose methods were injurious to itself, its distributors and the public.

"The company, therefore, accepted the indictment, and filed a demurrer to it, asking that it be dismissed. This demurrer has now been sustained and the indictment quashed in a sweeping decision upholding all of the company's contentions.

"The opinion states the vital issue raised by the indictment to be 'how far one may control and dispose of his own property,' and affirms the right of any owner of goods to sell them or not as he sees fit.

"The court recognizes the vital interest which a manufacturer has in the prices at which his goods are resold and the injurious effect upon his business which may be caused by price-cutting. It notes that the public is not by any means necessarily benefited by price cutting, but that a price cutter, after he has demoralized

the market for a product, may raise the price upon it again and individually profit by the operation. The court says: 'What the public is interested in is that only reasonable and fair prices shall be charged for what it buys, and it is not claimed that the defendant's manner of conducting its business has otherwise resulted.

"Pending this decision the Federal Trade Commission had adopted the view of the Attorney General and in a large number of proceedings before it held that a refusal to sell to dealers who do not adhere to indicated prices violates the Sherman Law, although it has also expressly ruled that selling below cost is an unfair and unlawful method of competition.

"Between these various conflicting rulings the law will not be finally established until the matter comes before the Supreme Court. The present case is the only proceeding of any kind before a Federal tribunal, squarely presenting this issue, in which any opinion has yet been handed down, and stands as the most carefully considered and deliberate expression of judicial opinion thus far uttered. The company is confident that it will be sustained by the Supreme Court."

FINE NEW QUARTERS IN PORTLAND

Hyatt Talking Machine Co. Now Settled In Fine New Home In That City

PORTLAND, ORE., November 4.—The Hyatt Talking Machine Co. are now permanently located in their handsome new quarters at 350 Adler street, where no expense has been spared in making the establishment one of the finest in the city, if not in the State, devoted exclusively to the sale of talking machines.

The equipment includes twelve soundproof booths for the demonstration of machines and records, all of them arranged with a view to both general attractiveness and convenience of both employes and patrons. Ample record space is provided and the record department is readily accessible from any of the booths. The booths are furnished with handsome rugs and draperies to match and supplied with commodious upholstered wicker chairs and tables. The display rooms have a capacity of about seventy-five machines.

The Hyatt Co. handle a well diversified line, including the Victrolas, Edison Diamond Discs, Edison Amberolas, Grafonolas and Brunswick phonographs, as well as a large stock of records for the various types of machines.

NEW "CONVERTO" MODEL

Just Announced by the Lundstrom Mfg. Co. to Accommodate Latest Victrola "VI"

The C. J. Lundstrom Mfg. Co., of Little Falls, N. Y., manufacturer and patentee of the well-known "Converto" cabinets for the small Victrolas, have announced a new model in the mahogany finish to accommodate the latest mahogany Victrola "VI" just out.

The Lundstrom Co. has also recently announced a new policy of distributing these cabinets through the jobbers only to the retail trade for the protection of both its wholesale and retail contingents.

The large representative list of wholesalers now handling the "Converto" cabinets is strong evidence of the merits of this unique cabinet. They have proven a tremendous success wherever introduced and offer an exceptional opportunity for Victor dealers in these times when cabinet machines are almost unobtainable.

The Chicago Talking Machine Co., who have been sending folders to their dealers, listing every record in their stock which they can ship at once, have received appreciative letters regarding this move.

PRESS THE BUTTON—

THE MOTOR STARTS

No Winding, No Noise, No Spring Trouble
THAT IS

THE VEECO WAY

The improved VEECO electric motor is designed primarily and exclusively for Talking Machines. It is smooth and noiseless in action and practically fool-proof. Standard models run on any voltage from 100-125, A. C. or D. C., without adjustment. Other models for any voltage from 6-250. Furnished mounted on 12 or 12½ inch mahogany board ready to install, or without board, all ready to mount on such board as used by the manufacturer.

With the VITRALOID turntable, supplied with the motor, it makes a complete motor unit for high class machines.

Send for a sample NOW and place your order at once for early delivery.

THE VEECO COMPANY

248 Boylston St.

Boston, Mass.

THE ORIGINAL PRODUCERS OF A COMPLETE ELECTRIC DRIVE
FOR TALKING MACHINE MANUFACTURERS' USE



Over There

Are given a few of the facts pertaining to a very remarkable opportunity.

If you wish to greatly increase your business this winter, with profits increased in proportion—

Sign the coupon printed below and mail same to us at once.

THOS. E. WILSON & CO.,
701 North Sangamon St.,
Chicago, Illinois

Gentlemen:—

Please send me particulars pertaining to your special proposition on Wilsonian Phonographs. I understand that this request places me under no obligation whatsoever.

Signed.....

Address.....

Sign This Coupon
And Mail It
To Us
To-day



A Complete Line

Backed By One Of The World's Greatest Trade Marks

WILSONIAN PHONOGRAPH

Seven Superb Models

Each of the seven instruments included in the Wilsonian line is designed and priced to appeal to a distinct buying class.

You will have a phonograph for each prospect if you handle the complete Wilsonian line

Wilsonian Prices Range

- \$ 45.00
- 55.00
- 80.00
- 100.00
- 115.00
- 135.00
- 165.00

There is a Wilsonian for every home.

Plays Any Record

The Wilsonian plays all makes of disc records with wonderful clearness and beauty of tone. It is not necessary to make annoying mechanical changes when varying styles of records are being played.

We are also National Distributors for, and always carry a complete Stock of, Paramount Records

Write To-day For Our Dealer Proposition

It Means Money To You



25 West
45th Street
New York

701 North
Sangamon Street
Chicago

Wilson & Co. branches are in all principal cities including:

Pittsburgh
Boston
Philadelphia
Baltimore
Salt Lake City

Buffalo
Detroit
Rochester
Cleveland
New Orleans

Denver
Omaha
Dallas
Atlanta
Los Angeles

Kansas City
Charleston
Memphis
Spokane
Minneapolis

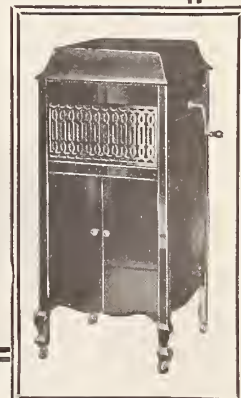



NEW!

The Columbia Record Catalog is out—the New one! And it's new all through—typography, pictures, material, arrangement. New and better.

**Columbia Graphophone Co.
NEW YORK**

BIG DEMAND CAUSES EMBARRASSMENT IN MILWAUKEE

Stock Shortage Makes Dealer's Problem One of Allotment Rather Than of Selling—Looking Forward to Post-War Period—Badger Co. President Honored—General News

MILWAUKEE, Wis., November 9.—The talking machine trade of Milwaukee is convinced that it is an unerring law of the business world that at a time when the demand is best the supply is shortest. That seems to be the outstanding feature of the situation at this time. In the face of probably the broadest and most urgent demand for talking machines and phonographs that has ever been known, not only are stocks in the hands of retailers low, but jobbers and wholesalers have practically nothing on their floors, and, to cap the climax, manufacturers have been requested to make a further curtailment of production.

This is not a rosy outlook on its face, but the prospect that within a short time the war-torn world will be delivered from great evil offers such encouragement that talking machine men are glad to make further sacrifices at the moment with the knowledge that they are on the threshold of a new wonderful era for their business.

The demand that has been created is not going to be dissipated very soon, in the opinion of local dealers and jobbers as well. There is every indication that it will far outlast the present period of short stocks and will manifest itself when that day comes when manufacturers again find themselves able to return to normal production. Therefore there is no gloom in the talking machine trade in Milwaukee.

"The demand for Victors unquestionably is the best and broadest in our experience," said Harry A. Goldsmith, secretary of the Badger Talking Machine Co., Victor jobber. "Supplies are perhaps the lowest they ever have been. On top of that we received notice a few days ago of further curtailment of production. That makes it a question merely of distributing such stocks as we can get in the most equitable manner. Our dealers must be satisfied to get delivery in the proportion that we are supplied. All of them, I think, understand the situation."

Mr. Goldsmith, like other keen students of conditions, looks forward to a post-war period of the greatest development of the talking machine business since this form of musical instrument was invented.

"Brunswick business is splendid" is the comment of Thomas I. Kidd, manager of the Brun-

wick-Balke-Collender Co.'s local branch. "If we had the goods I believe we could sell twice as many machines. Our dealers throughout Wisconsin and Upper Michigan report the largest sales ever known."

Charles J. Orth, distributor of the Puritan in Wisconsin and Upper Michigan, is conducting one of the most striking advertising campaigns this city has ever known. Mr. Orth is looking after the retail interests of the Puritan in Milwaukee and immediate vicinity and scarcely a day passes without the appearance of an Orth-Puritan ad. Mr. Orth is personally responsible for the "copy," which is distinctly new and attractive. He is co-operating with his retail representatives throughout the territory and furnishing them with similar "copy" suited to their peculiar local needs.

Frank H. Hochmuth, Victor dealer, 347 Third street, is receiving the sympathy of the talking machine trade at the death of his eldest son, Hans W. Hochmuth, who succumbed to pleuropneumonia, the outgrowth of Spanish influenza, at the base hospital at Camp Custer, Mich., on October 21. Mr. Hochmuth spent nearly three weeks at the bedside of his son to minister to his wants. The young man was thirty-two years of age and entered the military service in September, 1917. Previously he was his father's chief assistant in the store.

George F. Ruez, president of the Badger Talking Machine Co., Victor jobber, has been honored by Bishop Henni Assembly, Fourth Degree, Knights of Columbus, by election as faithful purser, or treasurer. Mr. Ruez is an active worker in the ranks of the K. of C. and has done some particularly effective work in the war camp activities of the order.

Many Milwaukee talking machine dealers located in the outlying sections are entering enthusiastically into the work now being done to co-ordinate the various neighborhood business men's associations into a central body known as the Milwaukee Federation of Local Commercial Associations. Community clubs to the number of eighteen already have joined the new body. This will greatly facilitate the administration and enforcement of rules and regulations issued by Governmental authorities to promote conservation of light, fuel, man-power and other

economies during the remainder of the war period and the era of readjustment and reconstruction afterward.

The new Aeolian-Vocalion records issued by the Aeolian Co. are becoming increasingly popular in Milwaukee under the vigorous representation given by the Edmund Gram Music House. Miss Julia Wolf, manager of the Aeolian-Vocalion department at Gram's, is doing splendid work in the promotion of both machine and record sales.

WISCONSIN SONORA DEALERS MEET

Seventy-five Sonora Retailers Guests of Yahr & Lange Drug Co. at Second Annual Convention Held in Milwaukee Recently

MILWAUKEE, Wis., November 2.—The second annual convention of Sonora dealers of Wisconsin and Upper Michigan was held in Milwaukee on October 23, at the invitation of the Yahr & Lange Drug Co., wholesale representative in this territory. Because of the ban placed upon public assemblages of all kinds by the health authorities to combat the spread of the epidemic of Spanish influenza, the convention was planned along less elaborate lines than originally intended, before the disease gained such a foothold as to virtually "close up" the entire city and State. Nevertheless, about seventy-five dealers were present and profited by the business sessions and enjoyed themselves at a dinner party. Frank E. Coupe, director of sales and advertising for the Sonora Co., was the guest of honor and contributed much to the success of the convention.

Business meetings were held at the Yahr & Lange wholesale house, and the dinner at the new Milwaukee Athletic Club. Fred E. Yahr, secretary of the company, who is giving his personal attention to the Sonora department, acted as toastmaster. H. M. Hahn, Sonora sales manager, was master of ceremonies. At the dinner Mme. Marie Yahr, wife of a brother to Mr. Yahr; Edna Boddin-Hahn, and Miss Audrey Eisendrath, all of Milwaukee, were soloists. Accompaniments and solos were given on the Sonora. Fleetwood Diefenthaler accompanied Mme. Yahr, who is a soprano of national note, in her principal selections. The convention was voted a great success, and every one who attended returned to his home much enthused and even more aggressive a booster for the Sonora than when he came. The gathering emphasized once more the good will existing between the Yahr & Lange Co. and its dealers, and the splendid spirit of co-operation that is making the Sonora known in every part of the Badger State.

PERSONAL SERVICE

The members of our Company are always available and will gladly see you personally or write you at any time we can possibly serve you.

Why not communicate at once with us?

BADGER TALKING-MACHINE CO. 135 Second Street
MILWAUKEE, WIS.
VICTOR DISTRIBUTORS

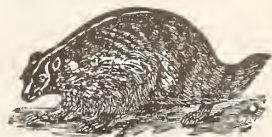

SEND FOR ILLUSTRATED PRICE LIST
AND FREE SAMPLE

"GLOBE" TRANSFER NAME PLATES

DEALERS EVERYWHERE APPLY THEM
ON PHONOGRAPHS, PIANOS, ETC.

GLOBE DECALCOMANIE CO.
JERSEY CITY, N. J.

ONE GERMAN SOLDIER IS HATLESS

L. C. Mountcastle, Formerly a Talking Machine Man in Pittsburgh, Sends Back the Helmet of a Prussian Guard as Souvenir

PITTSBURGH, PA., November 4.—The Standard Talking Machine Co. has just received a most interesting Boche souvenir from its former road man, L. C. Mountcastle, now a sergeant in the 103rd Field Signal Corps in France. The helmet is particularly interesting, inasmuch as it was worn by one of the Prussian guards, the crack German military organization, which re-

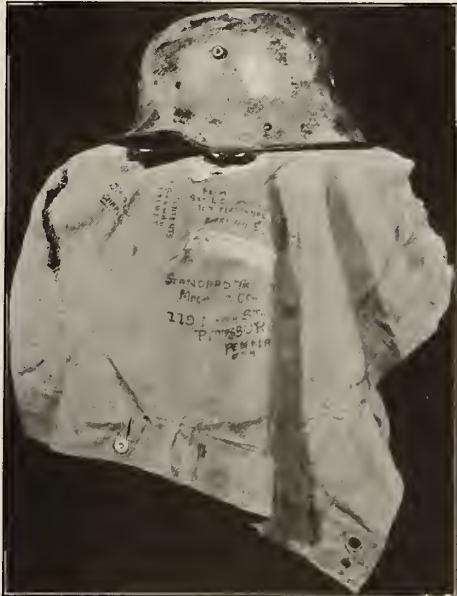

Sergt. Mountcastle's Souvenir

cently received such rough treatment at the hands of the American soldiers.

In sending the helmet Mr. Mountcastle wrote: "Thought maybe the office would like a German souvenir, so I am sending to-day a helmet worn by one who at one time belonged to the famous Prussian guards, the Kaiser's crack troop. Bill sent them against the boys from Pennsylvania and we showed 'em a new road to hell. You will notice the helmet is camouflaged, and it has the Prussian guard insignia on the side. Officers and men wear the same helmet these days. Only the most valuable troops are given helmets at all. Suppose Fritz is shy on metal.

"Never had so much money in my life. They pay us regular, but we have nothing to spend money on. Oui! if I ever hit Paris with all these francs, what a time I'll have!"

The new J. H. Remick Co. store in Cleveland will handle the Columbia line.

UNSOLICITED BUSINESS IN ATLANTA

Many Sales of High-Priced Instruments Made to People Who Close Deals on First Visit to Stores—What the Leading Houses Report

ATLANTA, GA., November 8.—The talking machine business in Atlanta and the Southeastern territory for the month of October was very satisfactory. The shortage of goods in all leading lines is affecting business to some extent, but at the same time sales are more easily made than ever before in the history of the industry. The purchases are made spontaneously, the case of one dealer being typical. He sold seven \$100 grade talking machines in one morning, and he had never heard of nor seen any of his customers before. Another dealer also sold a \$200 instrument and a \$115 instrument for cash to persons whom he had not solicited nor pressed to buy.

The Haverty Furniture Co., Grafonola and Pathé dealers, say that their business for October was indeed gratifying. Mr. Wilson, the manager, states that as fast as he can get Grafonolas opened and on display they are sold, placed on a truck and delivered. Practically all sales are from \$100 up. He states that the record business is large and growing all the time. The Haverty Co. report that all of their stores in Georgia, South Carolina, Alabama, Tennessee and Texas are doing a nice volume of business.

The Atlanta Talking Machine Co., Columbia and Aeolian dealers, report business as substantial in volume and satisfactory as to cash sales, first payments and monthly terms. They expect a continued large volume of business. There is an inclination to stiffen first payments and monthly terms all along the line. Geo. P. Howard, president of this company, is very optimistic for the future.

The Atlanta Phonograph Co., of whom it was recently announced in these columns that they had taken on the Columbia line, are reported as doing a fine business. They are fortunately located in a section of the city where there has never before been an aggressive, active dealer in any make of talking machine, and have an excellent location from a strategic standpoint. Mr. Riley, proprietor of the store, is highly pleased with his success with the Columbia line, and is looking forward to a most satisfactory winter and holiday trade.

The Cable Piano Co., exclusive Victor dealers, are doing as much business as they can with the amount of goods they are able to get. It is stated that they could in all probability sell any quantity of Victrolas that could be secured. Their record business is very large and all records are in active demand, the popular selections at 85 cents going literally like "hotcakes." Their business in Red Seal records is possibly the largest in the city.

Your correspondent in passing along the streets can see almost every day some new dealer in talking machines. All the old line companies are not qualifying any new dealers, but there are any number of new makes on the market, and some of them are of merit.

The Atlanta district went several million over the quota in the last Liberty Loan campaign, the city of Atlanta being about \$2,000,000 over.

At a recent meeting held in Atlanta there was formulated a plan for materially strengthening the stand retail merchants are making for large cash payments and greatly shortened terms on retail sales. Many merchants (talking machine dealers as well) have been for some months selling on shorter terms, and if the talking machine dealer could sell, as most other merchants do, on thirty, sixty and ninety days' time, it would possibly be the greatest step forward in the recent history of the industry, for the time has passed when the phonograph was a curiosity and those long years of approvals, cut-throat terms, and almost impossible competitive conditions, even for the largest and strongest dealers, have practically passed. It is very generally hoped that the new idea will take root and grow.

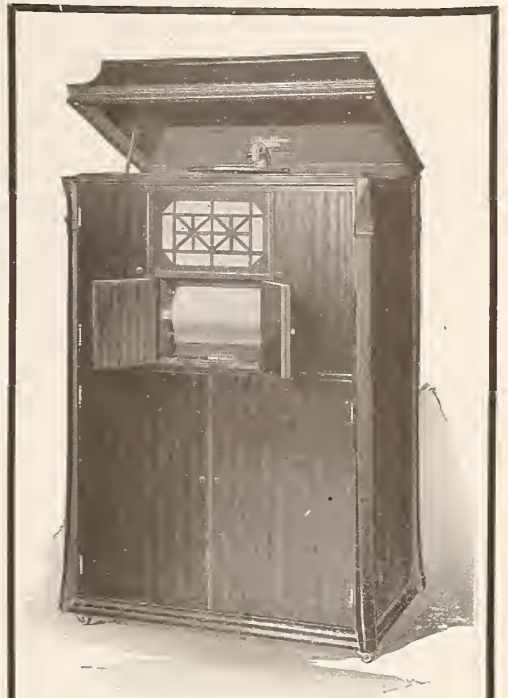

Phono-Grand

The Perfect Instrument for to-day's Musical Needs

A Reproducing Piano

and

A Splendid Phonograph

Beautifully and compactly combined; shape and size ideal for apartment or bungalow homes.

Piano uses QRS expression rolls. Phonograph Plays all Records.

Everybody is delighted with it, everybody wants it.

The Phono-Grand is the one best proposition for a big and quick seller this winter.

Write Now for Facts

J.P. Seeburg Piano Co.

209 South State St. Chicago, Ill.
419 West Erie St.

DEALERS

Offset the Record Shortage! Keep Your Sales-Force Busy! Sell Our Language Records!



French Spanish Italian

ALSO

F.M.C. FRENCH MILITARY CONVERSATION

Cash in now on the

Language Phone Method and Rosenthal's Practical Linguistry

It requires no scientific salesmanship to sell our records. The courses are so simply arranged that the demonstration satisfies the prospect. The French Military Course, 5 Double Discs, and Military Manual (Retail \$10.00) is ideal for Army, Navy, Red Cross

Our Display Signs Sell the Goods Send for Particulars — Prompt Delivery

THE LANGUAGE PHONE METHOD 992 Putnam Bldg., 2 West 45th Street, New York

HOLIDAY ADVERTISING CAMPAIGN ON IN INDIANAPOLIS

Talking Machine Dealers After Christmas Trade—Pearson Piano Co. Has Vocalion Line—How Epidemic Helped Record Sales—E. B. Knight Wounded—News of Month

INDIANAPOLIS, IND., November 6.—With the taking over of the entire line of the Aeolian Co. here, the Pearson Piano Co. will handle four makes of talking machines—the Victor, the Edison, the Cheney and the Vocalion.

The closing of Aeolian Hall at 237 North Pennsylvania street will be missed by Indianapolis music lovers. The entire building of three floors and a large basement was given over entirely to musical products, among which was the Vocalion. The securing of the line by such a prominent house as the Pearson Co. will, however, go far to fill the gap.

The bans issued by the city board of health in the effort to prevent the spreading of influenza and pneumonia have been lifted, much to the satisfaction of talking machine dealers, although this class of business was not hit as hard as some other lines of retail business for the reason that many people bought records to entertain themselves at home, everything else being closed up.

As soon as the board of health had issued its order closing theatres, schools, churches, etc., and also ordered that retail stores in the business district should not open up before 9.45 a. m. and close at 6.15 p. m., George F. Standke, of the Brunswick Shop, took advantage of the situation and inserted an advertisement in the newspapers directing the attention of the public to the drastic closing orders with the suggestion that talking machine owners lay in a stock of records and that persons not having a machine should make a bee line to the Brunswick shop and get one at once. The results from the appeal were gratifying.

Word has been received of the wounding in France of Emerson B. Knight, formerly advertising manager of the Stewart Talking Machine Co., wholesale jobbers for the Victor line here. Mr. Knight is with the marines in France.

The latest word from Mr. Knight is that he is recovering in an evacuation hospital. Knight was sent into action two weeks after his arrival in France. In a letter describing the event, Knight said the company of marines he was with were sent to assist some shock troops. He said the boche artillery was sending shells over rapidly and that his squad finally reached an abandoned German trench. Shortly after Knight said something hit him and that he knew no more until he awoke on a hospital cot. He was wounded in the shoulder and said he expected to be out of action for several months.

The talking machine and music dealers have joined together in an advertising campaign for the Christmas season. In page advertisements the dealers are appealing to the public among general musical lines, the names of the dealers being placed at the bottom of the advertisements. "Music is the spirit of Christmas" is the headline on the latest advertisement. The appeal also is made for early Christmas shopping.

HOW BUFFALO WENT 'OVER THE TOP'

BUFFALO, N. Y., November 6.—The talking machine and piano men of Buffalo went considerably over their quota, which was \$215,000 in the Fourth Liberty Loan drive, and officially received an expression of gratitude for the fine work from the general managers of the campaign. Previous to the drive there was a get-together dinner at the Hotel Statler, presided over by William H. Daniels, which helped materially toward the unification of the allied music forces. A feature of this dinner was the reelection of the following officers of the Talking Machine Dealers' Association of Buffalo: President, Thomas A. Goold; vice-president, E. G. Emens; secretary, Harry G. Towne, and treasurer, Mr. Biesinger.

R. W. GRESSER'S NEW POST

Has Become Associated With the Southern California Hardwood & Mfg. Co., With Headquarters in Los Angeles

R. W. Gresser, formerly sales manager of the Delpheon Co., Bay City, Mich., manufacturer of the Delpheon phonograph, has resigned from this position and has become associated with the Southern California Hardwood & Mfg. Co., Los Angeles, Cal. Mr. Gresser left for the Coast the end of last month, and according to present plans will have an important announcement to make regarding his new connection in the very near future.

In his present post in Los Angeles Mr. Gresser will have charge of the phonograph division of the Southern California Hardwood & Mfg. Co., and will have under his direction the manufacturing and merchandising of this company's popular line of phonographs. Mr. Gresser's past experience in the trade well qualifies him to assume this important position, and his intimate familiarity with every detail of talking machine manufacture will undoubtedly enable him to achieve pleasing success in Los Angeles.

While associated with the Delpheon Co. Mr. Gresser made frequent trips throughout the country, visiting the dealers and the leading jobbers. He made a careful study of the dealers' requirements, and left nothing undone to give the dealers 100 per cent. service from a manufacturing and sales standpoint.

The Southern California Hardwood & Mfg. Co. occupies the largest and oldest wood-working plant in the West, this plant covering eleven acres. The company has been achieving splendid success with its line of "Hawthorne" phonographs, and under Mr. Gresser's able direction the popularity of these products will undoubtedly advance steadily.

The Kaiser has not invested in War Savings Stamps. Are you like the Kaiser?

YOU LOSE

An opportunity, Mr. Dealer, unless you learn the MERITS and BIG FREE OFFER on

The ORIGINAL and Only SAFE POLISH, CLEANER and REVIVER for PIANOS, TALKING MACHINES and Delicate FURNITURE

"Not a Floor Oil"



Space will Not Permit the Explanation of the Wonders



PIANO CREAM Will Accomplish

A Distinctive Preparation for the Musical Instrument Trade

Packed in 15c., 30c., 50c. Tubes—also larger Packages. Write your Jobber at once for BIG FREE OFFER or communicate with

MASTER MFG. & SPECIALTY CO. CAMDEN, N. J.

Special Representative—Clement Beecroft

TRADE MARK
BEE CROFT

RECORD CABINETS

Record Envelopes

"Ready Files"

For Records

CLEMENT BEECROFT

309 West Susquehanna Avenue
PHILADELPHIA, PA.



Something brand new! Something infinitely more pleasing and satisfying! A real scientific discovery. A graphophone needle that draws forth such beauty and clearness of tone as has never been equalled. A needle that *doubles* the value of the phonograph—that *trebles* sales of needles! records!—machines!—that *quadruples* your profits! That will make your

store stand first and foremost in your locality. Don't put off! Send coupon NOW for *free* samples and price of the latest sensation—the greatest of all phonograph needles, the *Tonofone!*

BETTER STILL: Order a supply today. Increase your *Christmas* Sales of machines and records. We will give you the right wholesale price. Our *money-back-guarantee* protects you ABSOLUTELY.

“Tonofone”

The Talking Machine Needle That Puts Magic in Music

The Tonofone is made on entirely new principles, of entirely different materials. Instead of skipping or jumbling many of the finer microscopic undulations vibrated into the groove when the record was made, the smooth, resilient, platinum-like Tonofone point gets them all.

Nor does this wonderful needle dig into and mutilate the walls of the groove and so impair the record itself and the volume and quality of the reproduction. On the contrary, it preserves and prolongs the life of the record.

It transmits each separate tone in all the fullness and quality of the original rendition. It loses nothing—confuses nothing. It marks a dis-

tinct advance in phonograph music—a new epoch in the phonograph world.

Gone is the scratch—the twang—the squeak. Gone is the last lingering blemish to phonograph music! All is eliminated by the Tonofone. All is replaced by a beauty, a clearness, a matchless and mysterious *purity* of tone that has amazed listeners everywhere—that can be produced, positively, by *no other needle.*

Tonofone needles play all records, both vertical cut and lateral cut. Can be used on all modern phonographs and talking machines. Each needle plays from 50 to 100 records *faultlessly!* Sell at retail—4 for 10c in attractive package, 100 packages in a display carton.

Don't Be Hide-Bound by Precedent!
Blaze New Trails—Sell What the People WANT!

Be progressive! Be alive to fresh opportunities! Get in at the *beginning*—when ideas are *new*—when sales and profits are *luscious.* Put Tonofone needles in stock and sell the people what they want. One demonstration will suffice! Manufacturers, dealers, critics and public all crazy about Tonofone results. Send the *Coupon* and see for yourself.

Money-Back Guarantee If, for any reason, you do not find Tonofone needles as represented, and entirely satisfactory, you may return them at our expense and we will refund full purchase price.

PROMPT DELIVERIES No sales-losing *delays*—no profit-losing *waits*—not when you order TONOFONES. Immediate deliveries anywhere.



Mail the Coupon!

FREE Show-Me-A-Tonofone Coupon

Name.....

Address.....

Gentlemen:—Without obligation to us, send to above address samples of TONOFONE Needles, prices and full details of selling plan.

R. C. WADE CO.
29 S. La Salle St.
CHICAGO



By George!
George Cohan wrote it. George MacFarlane sings it. It's some record—"When You Come Back." Everybody's buying it—How are you fixed for a supply?

Columbia Graphophone Co.
NEW YORK

TWIN CITY DEALERS MAKING BEST OF WAR SITUATION

Members of Retail Trade Appreciate the Problems of the Factories and Make Allowances for Stock Shortage—Foster & Waldo Take on Sonora Line—Jobbers Flooded With Orders

MINNEAPOLIS and ST. PAUL, MINN., November 4.—Unless all indications fail every talking machine sent to Minneapolis and St. Paul before the holidays will be sold and the dealers will be yelling for more and more. As a matter of fact they are complaining already, and if it were possible to sour the nature of a talking machine man some of them would be quite bitter by this time. The dealers, however, are making the best of the situation, hoping to reap the reward later on of their present virtue.

"We realize fully that the Victor Co.'s loyalty in participating in the Government's wartime program has greatly diminished their output of talking machines and thereby greatly reduced the supply available for dealers," said E. F. O'Neill, of the Beckwith-O'Neill Co. "Their letters of September 13 and October 30, outlining their position, have been favorably received by the Northwestern dealers as unusually frank and able statements of the true situation, and the men in the trade are making the best of an unavoidable condition. From a wholesale standpoint it is now possible only to distribute machines and records in exactly the same ratio as we receive the same from Camden and to view the future with an optimistic mind. We are convinced that the end of the war will find the Victor Co. unimpaired from a manufacturing

standpoint and will be able to divert its organization immediately to the regular channels."

Foster & Waldo have added the Sonora line to their stock of Victor, Edison and Columbia machines. This house already is doing a holiday trade in talking machines, and the addition of the fifth line, the Brunswick, for instance, is in the range of possibility.

"We are helpless in the situation that confronts us," declared George Mairs, manager of the talking machine department of W. J. Dyer & Bro. "We are receiving orders from hundreds of points in the Northwest, which we are unable to fill."

The big Pathé stock of machines and records held by G. Sommers & Co. for distribution throughout the Northwest is going rapidly, according to Jay H. Wheeler, the manager. He reports that he already is barren of the popular No. 7 and No. 12 styles, and only has a fair supply of the other styles. Seven men are on the road throughout the Minnesota and Dakotas territory, and they virtually are swamping the headquarters with orders.

It's the same story with the Columbia Co.'s Northwestern headquarters. The road men are turning in such large orders that the local supply nearly is exhausted, and the producing factory fails to meet the incessant calls. The

year's business already is far in excess of the total for 1917 or any other previous year.

Excellent business is being done by the Cheney shops in St. Paul and Minneapolis.

A letter from Robert Souders, once Northwestern manager for the Columbia Co., to E. F. O'Neill conveys the information that the writer is having the time of his life. He is in charge of the Y. M. C. A. hut for officers in Winchester, England, and declares that it is a great privilege to work for the men who are putting the Huns on the run.

Skinner Chamberlain & Co., the big music house at Albert Lea, Minn., announces that it will confine its phonograph business to the Victor line, preferring to suffer a present sacrifice and have its full compensation later on.

The Edison sales in the Northwest, both in the retail stores in St. Paul and Minneapolis and the interior towns, already have exceeded the 1917 totals in the number of machines disposed of. The money value, of course, is far and away above the figures of last year.

Boutell Bros. are pushing the Brunswick line with characteristic energy and cleverness. The demands of the war have taken George M. Nye and his Brunswick shop is closed, at least temporarily.

F. A. DENNISON APPOINTED MANAGER

Takes Charge of Columbia Co. Branch in Buffalo, Succeeding O. M. Kiess, Who Enters Y. M. C. A. Overseas Service

Fred A. Dennison, formerly manager of the Columbia Graphophone Co.'s San Francisco branch, has been appointed manager of the company's Buffalo branch, succeeding O. M. Kiess, who has resigned in order to enter the Y. M. C. A. overseas service. Mr. Dennison is one of the "veterans" of the talking machine industry, and his host of friends throughout the country will be glad to learn of his appointment to the management of the Buffalo branch. He has for some time been desirous of residing in the East, and his wish is now gratified. Mr. Kiess, who has achieved signal success as Buffalo manager, will undoubtedly be a valuable addition to the Y. M. C. A. Overseas Corps, and in all probability will leave for France shortly.

SOLDIERS APPRECIATE MUSIC

Major-General Shanks Writes of Pleasure Given by Edison Machines on Troop Ships

In a letter recently received by Thomas A. Edison, Inc., Major-General David C. Shanks comments upon the contribution of the recently donated Army and Navy models to the contentment, not only of the troops en route, but also of the seamen and gun crews who are subjected to the constant hazard of crossing the sea.

General Shanks remarks also on his pleasure in the interest which the American people take in the moral welfare and wholesome entertainment of our men. He feels that such efforts are thoroughly appreciated by the soldiers.

MELOPHONE MOTOR

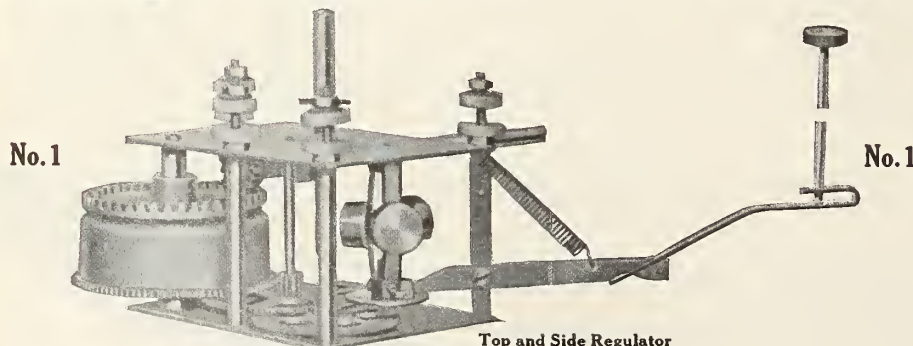

COMPLETE WITH 10-INCH TURN TABLE

Simple in construction, the most satisfactory and durable of all small motors.

Will play two ten-inch records with one winding.

Three years' successful record as the best single spring motor manufactured.

Immediate Deliveries Sample \$2.00

Write for Quantity Prices

Melophone Talking Machine Co.

380 Lafayette Street, New York

FURNITURE STORES FEATURING TALKERS IN PORTLAND

Prominent Establishments in Oregon City Give Much Attention to That Department and Handle Leading Lines—Stock Shortage Still a Problem—General Trade News

PORTLAND, ORE., November 4.—Nearly all of the big furniture stores of Portland are selling talking machines. Powers' sells the Victrola; Jennings' the Columbia Grafonola; Calef Bros. the Pathé; Gadsby's the Columbia, and Edward's the Columbia. All these are prominent furniture stores doing a big business in regular lines and delighted with the success of the different talking machines carried by them. All report good and increasing sales.

The demonstration rooms of the department in Powers' furniture store are very pleasing to the eye. Rose-colored carpets and curtains, easy chairs, beautifully shaded lamps make an attractive place to spend an hour or so listening to the records that are so willingly played for customers by W. B. Maxwell, in charge of the department.

The talking machine business at Wiley B. Allen Co.'s is doing remarkably well. Paul B. Norris, manager of the department, is keeping up his reputation as an excellent salesman. The Brunswick machine, which has recently been added to their stock, met with instant favor.

A Sonora has just been sold by James L. Loder, manager of the Bush & Lane talking machine department, to Captain Rouselite, of the French motor ship "Pecheney," a boat which was built in Portland. Captain Rouselite, who is an accomplished musician, was delighted with the Sonora as soon as he heard it. The transaction was for cash—the Sonora costing \$375. Since this sale there have been three other inquiries from boats in the harbor as a direct result of the sale.

Leonard Streibig, who has taken charge of the talking machine department of Wm. Gadsby & Sons, is having a successful fall trade. The Columbia Grafonola is sold by this house.

Mrs. Z. Baker, in charge of the record department of Sherman, Clay & Co., has been very ill, but has returned to work in her department. Miss Llewellyn, of the record department, has resigned and gone to the Sherman, Clay store, of Seattle.

H. E. Cress, who has occupied positions with several music houses, is now working for Bush & Lane Co. in the talking machine department.

The last Saturday in September was the biggest record day the Hyatt Talking Machine Co. has ever had. Business is rushing in their new location.

Edward's furniture store is having a good talking machine trade, said M. W. Davis, who is in charge of the department. This store carries the Brunswick, Vitrola and other machines.

W. H. Burr, who has been manager of the talking machine department of Gadsby & Sons, retired on account of ill health and has been succeeded by Leonard Streibig.

W. E. Dodds, who has been in charge of the talking machine department of Powers' furniture store, has enlisted in the navy and is in the radio branch of the service in San Francisco.

"We are away behind in orders," said L. E. Gilman, manager of the Stradivara Co. "Business couldn't be better. The new OkeH records are in and dealers are exceptionally well pleased with them." Mr. Gilman has placed a new agency in Seattle with the Standard Furniture Co.

By a unique method G. F. Johnson, of the G. F. Johnson Piano Co., has arranged his windows in a manner that displays a hundred feet of Victor records at one time. The effect is highly pleasing to the eye, and Mr. Johnson says it has resulted in large increase of record sales. Robert Callahan, who was head of this department, has gone to the Officers' Training Camp at the University of Oregon, his place being filled by Miss Hayes.

J. L. Loder, in charge of the talking machine department of Bush & Lane, is convalescing from an attack of influenza, as is H. E. L'Anglaise, manager of the Remick Song Shop.

The phonograph department of the Meier & Frank Co. is doing an excellent business. J. H. Matney is head of the department.

Miss Florence Isaacs, of Lipman, Wolfe & Co.'s sheet music and Victrola departments, reports a big record business. The Victor is the only machine carried by Lipman, Wolfe & Co.

A fine business is being done by the Brunswick-Balke-Collender wholesale house. This company furnishes Brunswick machines to dealers all through the State, and has six dealers in Portland. A. K. McKinley is manager of

the Portland branch, and A. W. Wettler is the credit man.

"The Record Shop" is a new institution in Portland. This little shop is situated in the Heilig Theatre Building—a most desirable location—and is conducted by C. H. Williams. Columbia records are on sale exclusively.

L. D. Heater, manager of the Columbia Graphophone Co., says they have all the business they can take care of, but few machines. There are plenty of records and that part of the business is better than ever. Frank Dorian, who has been appointed manager of the Seattle branch, is due in Portland in a few days.

Good advertising is force applied at the right point.



Paramount Records

New Releases Now Ready

30074	{	Smiles—Fox Trot, Dance Orchestra	
	Djer Kiss—Waltz, " "		
30076	{	K-K-Katy—Baritone Solo, Arthur Fields	
	When You Come Back—Tenor Solo, Henry Burr		
50006	{	Oh, How I Hate to Get Up in the Morning—Medley One Step	} Roger's
	Rock-a-bye Your Baby—Medley Fox Trot		} Band

Dealers and Jobbers

Good Profits :
Real Sales Cooperation :
Prompt Deliveries :
Are You Interested ?

MUSIC
ON BOTH
SIDES

NEW YORK
RECORDING
LABORATORIES
Port Washington
Wisconsin

65¢
TO
\$1.25

WE ARE CLOSING
JOBING RIGHTS
AND TERRITORY
VERY FAST

What About You?

HOFFAY IS PROVED
TO BE THE HIGHEST
QUALITY LINE THERE
IS TODAY



During 1917 our increase of
sales over 1916 was
1808%

See Talking Machine World issue March 15, 1918

During the first 10 months
of 1918 we have sold

Nine Times As Much

as during 1917

**HOFFAY TALKING
MACHINE CO., Inc.**

3 West 29th Street, New York City

PLANT IN WHICH THE PARAMOUNT RECORDS ARE MADE

CHICAGO, ILL., November 9.—Perhaps many people in the trade still fail to realize that within ninety miles of Chicago we now have a modern talking machine record plant of large capacity and where the dealer desiring to be posted intelligently regarding the product he handles can witness the pressing of records under the most favorable circumstances.

As can be seen by the accompanying illus-

Grafton, the town in which it is located, is but eight miles from Port Washington, Wis., where the general offices of the company are located.

The recording laboratories are located in New York, where the largest possible opportunity for securing instrumental and vocal talent exists, and is under the direction of Walter Rogers, a man of years of experience in the selection of recording talent. Both the laboratory experts



The Factory of the New York Recording Laboratories, Grafton, Wis.

tration, the plant in which the Paramount records are made is ideally adapted for the purpose. It is literally a daylight factory and is admirably located so far as labor supply is concerned; in fact, the company has experienced no inconvenience whatever in this respect. Transportation facilities are of the best, and

and the capable superintendent of the pressing plant at Grafton are men who were secured by the Paramount interests after years of experience with the old Eastern record producing concerns. Remarkable progress has been made in the organization of the distributive channels, and the sales manager, M. A. Supper, has re-

Geo. A. Lowe Co.
OGDEN, UTAH

Sole Distributors of
HOFFAY PRODUCTS

for the State of Utah, East-
ern Nevada, Western Wy-
oming, Southern and Eastern
Idaho.



cently added a number of prominent concerns to the already formidable list of distributors. The demand for Paramount records has grown so rapidly in the last few months that it has required the installation of a number of new presses at the Grafton plant.

A PLEASING SOUVENIR

The Brilliantone Steel Needle Co., Marbridge Building, New York City, are distributing throughout the trade a very handy and attractive souvenir in the form of a leather-covered perpetual memorandum book, which will be found invaluable to recipients.

Pathéphones for holiday gifts are commanding a ready sale at the A. F. Koenig Piano Co.'s store in Buffalo, N. Y.

THE RESURRECTONE



(Trade Mark Registered)

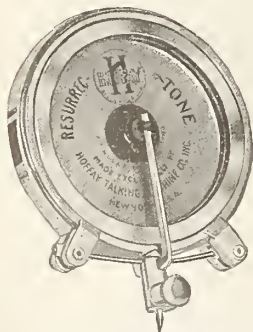

"A music lover will never hesitate to pay \$10 for a reproducer that trebles the musical value of his records."

Is the only reproducer giving sounds proper intonation and rhythm, combined with such naturalness and "warmth" of color as to make them a true *resurrection* of the original.

Using loud tone needle it gives greater clearness and volume of sound and fully 50% less surface scratch than any other reproducer; with a soft tone needle or fibre needle the beauty of the reproduction is just what it should be.

Prominent dealers, upon testing this supreme reproducer, state that they had not heard their records before. Superb in voices—colossal in instrumental, orchestras and bands. The "Resurrectone" makes your records more salable.

One model fits Victor Victrolas, Sonoras, and attachment for Edisons. Other model fits Columbia machines exclusively. Send for samples. Unless our claims are justified, return at once. Fully guaranteed. Net dealers' prices, \$5.40 nickel plated; \$6.75 gold plated. Retail prices, \$10 and \$12.50, respectively.

Write for exclusive territory proposition.

HOFFAY TALKING MACHINE CO., INC. 3 WEST 29TH ST. NEW YORK CITY

Read the Trade Mark carefully,
hear the machine, and you'll
agree that it is truly
The World's Musical Instrument
Improves All Records

\$125



Height, 44
Width, 20 1/4
Depth, 20 1/4

Other Models
\$175, \$225, \$275

VICTOR TALKING MACHINE CO.'S WAR STATEMENT NO. 2

Governmental Action in the Matter of Curtailment Output Set Forth and Commented Upon on Statement Sent Out Under Date of October 30 for Benefit of Dealers

Following the issuance of their first "War Statement" to the trade on September 13, which, incidentally, aroused much interest, the Victor Talking Machine Co., over the signature of Ralph L. Freeman, its secretary, issued "War Statement No. 2" on October 30, setting forth the report of the conferences between the representatives of the industry and the members of the Priorities Committee and the Conservation Division of the War Industries Board and the rulings regarding curtailments and other matters that had been issued as a result. The statement in full reads:

War Statement No. 2

To the Trade—The numerous appreciative and very intelligent letters received in response to our "War Statement" of September 13 leave no room to doubt that the trade is intensely interested in developments due to the war which affect manufacturers of talking machine products, and we therefore issue this additional statement covering the period since September 13.

On September 14 the Priorities Committee of the War Industries Board of the Council of National Defense gave a courteous and prolonged hearing to the War Service Committee of the Talking Machine Industry, at which conference the needs of the Government for its war program were stated and full confirmation was given to our

previously announced belief that the administrative officers of the Government would not curtail or in any way injure our own or other important industries beyond the point made absolutely necessary by the requirements of the war program. At the same time it was pointed out that substantial sacrifices through reduction in volume of output would be required of all industries except actual producers of vital war materials to the end that labor, materials, fuel, transportation and capital may be diverted in sufficient volume to the purpose of making a thorough and quick job of winning the war.

Following the conference above referred to, the Commissioner of Priorities under date of September 30 issued a ruling which applies to all manufacturers of talking machines and of which the important features are as follows:

1. A reduction of 60 per cent. in consumption of iron, steel, copper, brass and aluminum in manufacture of instruments during the last four months of 1918 as compared with a similar period of 1917.

2. Permission to purchase the materials necessary for the new schedules of manufacture will be furnished to manufacturers on condition that they and their customers will observe the required pledges as to economy in use thereof.

Schedules for next year are to be the subject of further conference with the War Industries Board, but a comparison of the restrictions now imposed upon the manufacture of talking machine products with those in force

against other commodities encourages us to believe that the War Industries Board has a comprehensive view of the situation and will be as considerate in arriving at future decisions as the necessities of the case will permit.

Conferences have been also had with the Conservation Division of the War Industries Board for the purpose of deciding upon practical economies in our industry. At this point it should be borne in mind that upon the degree of our co-operation with the Conservation Division depends in a large measure the consideration that we may expect to receive from the War Industries Board, which is the controlling body. As a result of these conferences manufacturers will be asked to make many changes calculated to conserve the essentials mentioned in the second paragraph hereof. You will be fully informed of these changes as soon as they are definitely determined upon, and we have the greatest confidence in your willingness to co-operate in this means of service to the Government.

A report by the War Service Committee of the talking machine industry covering some of its activities to date and including the order of the War Industries Board is being printed. This report, while prepared for the manufacturers, will doubtless be of interest to wholesalers and retailers and we have, therefore, ordered sufficient copies which we will mail, soon as received, to our valued customers. We bespeak your careful perusal of this report, from which it will be seen that the interests of the trade have not been overlooked.

We feel that it would not be proper to encourage too optimistic a view of the future and would be inclined to suggest that dealers prepare for a possible continuance of the curtailment in volume of Victor output, but we feel justified in pointing out the obvious facts that (a) the forehanded acts of the Victor Co. in obtaining Government contracts is distributing our carrying expenses over a much greater total output than would otherwise be possible and thus continues in a measure our economical methods of manufacture; (b) the unavoidable confusion connected with curtailment of a manufacturing program has, with us, been passed; (c) the continuance of our organization is assured and this will place us in an advantageous position at the cessation of hostilities; (d) all these benefits to the Victor Co. accrue also to its trade, who will quickly see the advantage to all concerned of carefully considering the entire situation before indulging in experiments with substitute lines of goods.

NEW HEINEMAN REPRESENTATIVES

Miller & Bloch, New York, Appointed Jobbers in Greater New York for Heineman and Meisselbach Products, Including OkeH Records

The Otto Heineman Phonograph Supply Co., New York, has announced the appointment of Miller & Bloch, 110 East Twenty-third street, New York, as jobbers for Heineman and Meisselbach products in Greater New York. This firm has already started an energetic campaign in behalf of these products and particular attention will be paid to the development of Heineman "OkeH" record business.

Both Mr. Bloch and Mr. Miller have spent several years in the talking machine industry, and are well known in the local trade. Mr. Bloch has called upon the dealers in Brooklyn and Long Island for several years past, and is familiarly known as "Will" to the great majority of the local trade. He is an indefatigable worker and thoroughly appreciates the importance of rendering the dealers efficient service and co-operation. "Dave" Miller will take care of the Manhattan

side of East River and the Jersey side of the Hudson, and Mr. Miller is planning an intensive campaign in his territory.

Miller & Bloch are firm believers in the value of efficient transportation service, and their dark red delivery wagons are already winning considerable popularity in the local trade. One of these wagons is shown herewith, and the "OkeH" record sign gives the body of the truck a distinctive and artistic appearance.

In addition to motors, tone arms, records, re-



Messrs. Miller and Bloch and Their Delivery Wagon

pair parts, etc., Miller & Bloch will also handle a complete line of music rolls, and this important branch of their business bids fair to assume large proportions in the very near future.

VICTORY LOAN MESSAGE ON RECORD

Canadian Minister of Finance Makes Record In Support of Recent Loan Drive

TORONTO, ONT., November 2.—One of the features of the recent Canadian Victory Loan drive was the manner in which the talking machine aided in bringing the message of the loan to machine owners in every part of the Dominion. Just before the opening of the loan drive Sir Thomas White, K. C. M. G., Canadian Minister of Finance, made a special "His Master's Voice" record for the purpose of actually informing the public, in his own voice, concerning the need for the second Victory Loan. Many thousand records of Sir Thomas' speech were distributed.

EDISON DEALERS ENLARGE

The C. F. Murray-Smith Co., of Wilkes-Barre, Pa., are enlarging their Edison department. The contemplated changes will make the department some fifty feet in length with two booths on each side, and a disc and Amberola display in the center.

Do your "two bits." Get another Thrift Stamp.

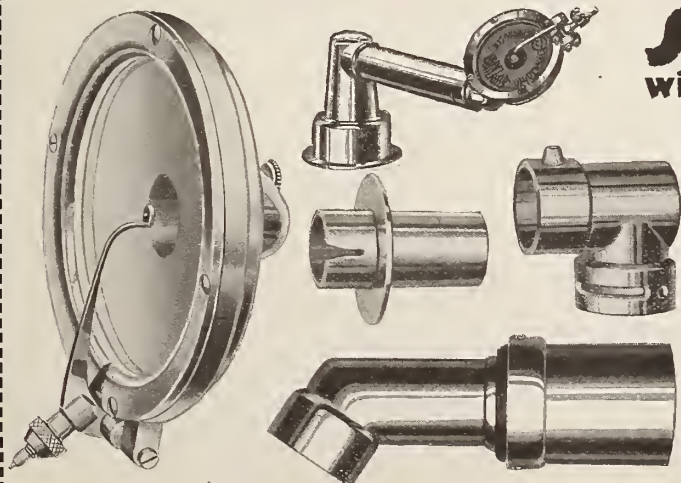

Superior Die Castings will Cut Your Costs and Increase Your Sales

Tonearm and Reprodncer Parts, Attachments, Turntable Hubs, Motor Governor Discs, Knobs, Piano Player Parts—accurately cast in Aluminum, White Brass, White Metal Alloys or Zelco Metal—ready for nickel or gold plating. We employ a large force of die makers especially skilled in this class of work and operate a large battery of die casting machines of our own design and construction with a capacity of 50,000 to 100,000 castings per day.

Write for Samples of Work we are doing in this line



Send us your Specifications or Models for quotations

Barnhart Brothers & Spindler
Monroe and Throop Streets Chicago Illinois

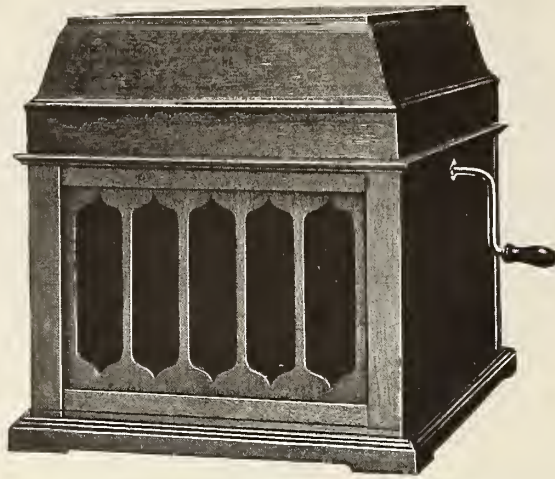

THE NEW EDISON DIAMOND AMBEROLA
MODEL 50

A MODERN JACK THE GIANT KILLER

Sixty-five Phonograph experts faced a
curtain behind which were a

New Edison Diamond Amberola

and a \$200.00 "Talking Machine" of well-known make. Unseen, the instruments alternately played the same selection. A vote was taken that *unanimously* favored one of them. It was the Edison Diamond Amberola that had defeated its much higher priced rival.

This is only one of many similar tests, always with the same result, that have earned for the New Edison Diamond Amberola the title of "Giant Killer."

THOMAS A. EDISON, Inc.
Amberola Department
ORANGE, N. J.

TWO NEW VOCALION RECORD ARTISTS

First Recordings of Maurice Dambois, Famous Belgian Violinist, and Colin O'More, the Irish Tenor, Announced by Aeolian Co.

The Aeolian Co., New York, made two important announcements of new Aeolian-Vocalion artists last week; these two additions to the Vocalion record library being Maurice Dambois, the famous Belgian violinist, and Colin O'More, the gifted Irish tenor. Both of these artists will record for the Aeolian-Vocalion



Colin O'More
A great future awaits this splendid young tenor, whose voice of extraordinary beauty will be recorded exclusively on Vocalion Records.

Following his recital at Aeolian Hall on Saturday, October 19th, Colin O'More is engaged for a recital tour which will cover the principal musical centers of America and will familiarize thousands of music lovers with the delightful charm of his artistry.

COLIN O'MORE
The Gifted Irish Tenor
WILL MAKE VOCALION RECORDS EXCLUSIVELY

COLIN O'MORE promises one of those rare voices that makes you glad to sit at the feet of the song-declamer. This talented young tenor adds new beauties of tone and

Announcing the O'More Records

library exclusively, and their first records are now ready for presentation to the trade.

In accordance with its usual custom of introducing its artists to the general public through the medium of attractive advertising, the Aeolian Co. carried artistic large-sized advertisements in the leading New York newspapers advising music-lovers that these two artists have joined the Aeolian-Vocalion library. These advertisements are shown in part, and the dignity and quality of the Aeolian-Vocalion phonograph and record library is reflected in this advertising.

Maurice Dambois, who has won international



The Famous Belgian Cellist
MAURICE DAMBOIS
WILL MAKE VOCALION RECORDS EXCLUSIVELY

MANY critics have pronounced this distinguished young artist the greatest cellist of our day. Certain it is that the Vocalion Records of his art are the most beautiful phonograph reproductions of cello music ever heard. Appealing and sympathetic as the cello is always, the Dambois Vocalion Records bring out in perfection the natural beauty of the instrument and present a wonderful tone-picture of the playing of this master cellist.

The AEOLIAN-VOCALION

The Dambois Announcement

fame in musical circles, was born in Belgium in 1889. Like most musical artists who are entitled to be called "great," his extraordinary talent became evident at a very early age. He made his debut before Her Majesty Queen Henriette of Belgium at Spa, playing the Saint-Saens concerto in "A" minor, and at the age of fifteen was acclaimed a virtuoso. He had won unlimited praise from leading critics here and abroad.

At a recent recital which he gave in Aeolian Hall the local newspapers spoke of his per-

H. J. SMITH—Jewel Manufacturer
MANUFACTURER OF—Phonograph Diamond and Sapphire Reproducing Points—Recording Laboratory Jewels—Jewel Bearings for Electrical Instruments—Rough Diamond—Diamond Powder—Experimental Work.

Telephone 2896 Market
833 BROAD STREET NEWARK, N. J.

formance enthusiastically, one well known critic stating in part as follows:

"For beauty of tone as well as mastery of the resources of his instrument Maurice Dambois, who held the interest of a large audience at Aeolian Hall last evening, is scarcely surpassed by the great Casals himself, while the young Belgian player has greater warmth of temperament. Maurice Dambois makes his violoncello both sing and dance, and occasionally discourse in eloquent and moving speech, and there is no fine tone effect which seems impossible to him."

Musical critics who have had an opportunity of listening to Colin O'More, the young Irish tenor, predict that a great future awaits this splendid young artist, who possesses one of those rare voices which give new beauties of tone and interpretation to the old familiar ballads that everyone loves. His vistrory is both finished and spontaneous, and his Vocalion records have reproduced Colin O'More's voice with remarkable fidelity. His first Vocalion records include "I Hear You Calling Me," by Marshall, and "Bonnie Sweet Bessie," by Gilbert, and there is no doubt but that Vocalion dealers will find a wide demand for these records.

It is interesting to note that following his recital at Aeolian Hall on October 19, Mr. O'More was immediately engaged for a recital tour which will cover the principal musical centers of America and which will give thousands of music-lovers a chance to familiarize themselves with the delightful charms of his voice.

REVIVAL OF THE "CHANTEYS"

Records of Famous Old Sea Songs Coming Into Favor With Thousands of Boys Who Are Being Trained for the Merchant Marine

WASHINGTON, D. C., November 7.—In these times in fact landlubbers may see "counterfeit presentments" of sea sights and hear sea sounds, very near the real thing, without going far from their own firesides, or if they may not do so to-day, the time is not far off when they will, for a concerted effort is being made to bring home to the people all that may be "canned" of the movement and accents of sailors' life.

In this educational effort—for it is such, purely, undertaken from various angles by various people, but under authority of the United States Shipping Board, official sponsor for the Merchant Marine—some novel effects are being worked out.

For example, in due time it may be expected that sailors' songs and sailors' chanteys—as sung in forecastles and at tasks on deck when Jack, the Merchant Mariner was a personage afloat and ashore, as he is getting to be again—will be reproduced in the records of the family phonograph.

Chantey singing is being revived in the Merchant Marine, at least on the training ships which are preparing Young America, at the rate of 4,000 lads a month, for service on our vast new commerce fleets, and under the new order of things it will be possible for Bangor, Maine, and Mesa, Arizona, to hear in the same hour the actual notes and phrases of such famous chanteys as "Shenandoah," "Bound for the Rio Grande" and "Blow the Man Down," for the record may have them hard and fast before spring flowers bloom again.

Even the nautically classic songs of Charles Dibdin, the song-writer par excellence of the sailor, may not be counted too old, in spite of their 150 years, to find a place beside Caruso, and Galli-Curci in the family cabinet of talking machine records.

Quite in keeping with the times, in fact, will be the rolling chorus of that noble sentiment to "The Lass Who Loved a Sailor"—that old-time favorite with men of the sea:

But the standing toast that pleased us most
Was "The wind that blows and the ship that goes,
And the lass that loves a sailor."

Immediate Deliveries

The Charmaphone

An Instrument of Supreme Value, Tone and Quality

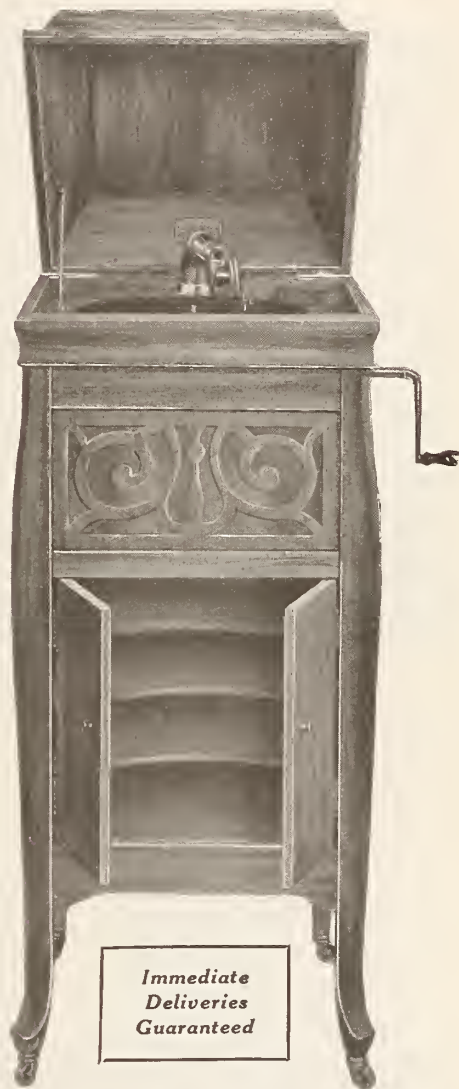

Immediate Deliveries Guaranteed

No. 100

Wholesale Price \$42.50 and War Tax Terms 5%—10 days, Net 60 days.

A high class Mahogany finished Cabinet 44" high and 18" wide and 21" deep.

It is equipped with a Heineman No. 3 Motor which will play five records without rewinding and is guaranteed by the manufacturer.

The large Tone Arm and Sound Box used is the same as used by other manufacturers of machines selling as high as \$200.00.

The record cabinet has three shelves as illustrated. It is equipped with a modifier and ballbearing casters.

All parts heavily nickel plated. This machine must be seen to be appreciated.

Let us send you a Sample Machine.

We carry a line of Phonographs from \$9.50 up.

Write for Catalogue and Price List.

R. L. Kenyon Mfg. Co.
Mexico, N. Y.

BOOSTING RECORD BUSINESS DURING THE HOLIDAY SEASON

Record Gift Certificates Prepared for Use of Victor Dealers a Most Successful Method of Developing Record Trade—Convenient and Time Saving for the Dealers

One thing the trade can apparently be sure of is that the Christmas demand for talking machine records for gift purposes will be fully equal to that of other years regardless of whether sufficient stock will be available to take care of the demand. Many factors combine to make the giving of talking machines and talking machine records appeal to the average buyer. The scarcity and advanced prices in all the usual lines of Christmas goods, coupled with the

feel just sure of that friend's desires, a gift certificate will prove particularly convenient. The certificate calling for records of a given value, and of the recipient's own selection, means that the recipient is going to get just the records that he wants, and that he will feel most appreciative both of the gift and of the spirit of the giver.

To the talking machine dealer the certificate will save the sale of a customer who wants to

gift certificate, illustrated herewith, the success of which the past years has warranted its continued use.

MILITARIZING THE HOME

A Chicago Imperialist Would Employ the Talking Machine as a Factor to Attain This End

A writer in the "Hit or Miss" column of the Chicago Daily News conceives the happy idea of militarizing the householder by the following method:

"Some time ago we discovered that by rigging up the alarm clock to the phonograph so that the latter played 'The Star Spangled Banner' we could induce the family to stand up at a proper hour of the morning and, at the same time, we could take the horror out of the alarm clock's wild shrieks. In this way there is nothing personal in this matutinal summons. There is the big idea—you can set up a mechanical tyrant, a just one, to be sure, as inexorable as the law of the Medes and Persians, and yet escape blame. It smacks somewhat of socialism and Prussianism, but in these times we must fight the junker with fire. The army bugle calls serve admirably in a phonograph-alarm clock ordered household. From reveille to taps there is a signal for almost everything, a mechanical reminder of duties to be done. Of course, somebody must adjust the alarm clock right along and change the records, but we expect the manufacturers of phonographs to take up this idea and give us soon a clockwork phonograph that will need but one winding a day. With one of these in every home life should be one grand, sweet, mechanical something or other."
Righto! But hasn't our friend just observed the result of the militaristic policy in Germany? Cause of real war! In these days when the world is "fighting for democracy" we doubt if this militaristic scheme of making home life one grand, sweet sob will go "over the top."

A GIFT FOR CHRISTMAS DAY-- AND EVERY OTHER DAY

THE VICTOR GIFT CERTIFICATE eliminates the difficulties of selecting suitable gifts for your family and friends. Properly endorsed, this Certificate enables the recipient to choose Victor Records from the Victor Catalog comprising more than six thousand selections.

This year above all others music will prove a source of inspiration and comfort in millions of homes.

Sign your name on lower line, the recipient's name on top line and return to us, specifying the amount. The Certificate will be mailed to any address you direct, timed to arrive on Christmas Eve.



Form of Gift Certificate for Use of Victor Dealers

Government's request that Christmas giving be confined to useful articles and not simply special holiday goods, will turn the thoughts of many to music, particularly in view of the prominence that music has assumed in the affairs of the country to-day.

The campaigns now being carried on to influence Christmas buying will, of course, and for that matter are, having their effect, but, although these campaigns may serve to spread Christmas buying over a more extended period than usual, there must undoubtedly be expected some holiday rush. To offset this rush and to make the strongest appeal to the person who desires to make an acceptable gift to a friend who owns a talking machine, but who does not

give records, but hesitates about selecting them himself. It likewise means that the records called for in the gift certificate will be selected after Christmas, and after the bulk of the holiday rush is over, thus insuring a considerable saving of time in selling records for direct giving during the week or two before Christmas, when the time of the salesman is most valuable.

The gift certificate for records likewise brings the recipient to the store with which he perhaps has had no previous business dealings, and opens up for the live salesman a chance for booking a new record customer.

The Victor Talking Machine Co. has as usual provided for the use of its dealers the attractive



Don't Lose the Business Momentum

It's Harder to Start and Gain Speed Than It Is to Keep Going—Don't Put on the Brakes

We are putting forth every effort to back up our dealers, not only with available stock, but with sales promotion material and exploitation plans that will keep the pep in their business until conditions become normal.

Our Business Now—and Always—Is to Help as Well as Wholesale

ECLIPSE MUSICAL CO.
CLEVELAND OHIO

**HIGHER PRICED MODELS
SOUGHT IN CINCINNATI**

Jobbers Have Hard Work to Get Machines to Satisfy Demands of Dealers—Big Vocalion Business—Wurlitzer's Victor Trade

CINCINNATI, O., November 8.—Buyers in the Middle West are seeking the higher priced models, this being the feature of the trade during the latter part of October and will continue throughout November, according to a number of the jobbers.

Just now there is a wild scramble on the part of the jobber to get all goods possible. Each and every member of the trade looks forward to a complete clean-up of the stock which can be accumulated between this week and the holiday season. Dealers are using all kinds of schemes to increase their supplies, but the material is not available.

The Phonograph Co., for one, is now receiving freight in less than carload lots and some shipments by express, this being a novelty. Muncy Bros., Richmond, Ky., and the John B. Carlisle Co., Lebanon, Ky., have taken on the Edison line.

C. L. Byars, of the Aeolian Co., reports the closing of the biggest October business in the Vocalion department in the history of the local Aeolian store in Cincinnati. Over 50 per cent. of the business was cash business, and most of the instruments sold were of the larger types.

Each of the five salesmen in his department was given a quota for the last ten days of the month, and there was considerable rivalry among the salesmen in their efforts to exceed their quota. The last four days of the contest closed up in regular holiday fashion. With the Liberty Loan drive closed and the epidemic conditions rapidly improving, we have every reason to expect November to be a big month.

T. Sigman, Victor department, The Rudolph Wurlitzer Co., reports excellent business during October and the first few days of November, saying: "Mostly all of our dealers reported excellent business for the month of October, considering the great shortage of Victor Victrolas and records, to say nothing of the influenza epidemic. Accessories helped both the wholesale and retail departments of the Wurlitzer Co. to relieve the machine and record shortage somewhat. A special drive was made on record albums, record cabinets, fibre needle cutters, record lites, and books of the opera with excellent results.

"Buy now" was the Wurlitzer slogan for the past month and the early shoppers were very much in evidence. A marked increase in the sale of Red Seal records was noticeable and we are looking forward to the November and December months to be the banner Red Seal record months."

Restrictions are not bothering the Crystola Co., which expects to close the year with absolutely clean stock floors. The Cincinnati company finds it easiest to ship to all points of the compass but due East. Albert Swing, president, declares the outlook to be most favorable.

Many of the dealers in the Cincinnati district were looking to the Cable Company to dispose of its stock of Victrolas from the Cincinnati store in chunks, but such is not the case. All supplies have been shipped to the store at Atlanta.

DEATH OF HERBERT MACK

Prominent Music Dealer of Indiana Passes Away After a Brief Illness

Herbert Mack, owner of the Sonora Music Shop, Elkhart, Ind., and also owner of music stores in South Bend and Laporte, Ind., died at his home in Laporte recently after a brief illness following an operation for appendicitis. In addition to owning the music stores Mr. Mack was assistant purchasing agent for the Rumley Co. in Laporte. He was forty years old and is survived by a widow.

**MR. "VICTOR" DEALER
JUST THINK THIS OVER**

These are strenuous times and the DEALER who has his Christmas stock on hand is indeed fortunate. As usual there will be a great demand for cabinet type machines. Are you prepared to meet this demand or do you intend to go through the most profitable season of the year WITH A LIMITED STOCK?



Patented December 11, 1917

TALKING MACHINE CABINET

has already solved the Christmas problem for thousands of DEALERS. These cabinets are made to accommodate the small Victrola models and double your profits when sold in connection with same. It also enables you to place a cabinet type machine at a moderate price within the reach of a class of people who will not consider any other make than a VICTROLA with all of the advantages of the more expensive models.

Present owners of the small Victrolas will readily appreciate the advantages of the "Converto" and by circularizing this field in connection with your record business you will easily revive interest in your line. "CONVERTO" sales will result in increased RECORD sales.

The C. J. Lundstrom Mfg. Co., Little Falls, N. Y.

LUNDSTROM "CONVERTO" CABINETS are broadly covered by patents. Infringements will be promptly prosecuted.

STRONG SELLING POINTS

Lundstrom "Converto" Cabinets are made in OAK and MAHOGANY FINISHES and convert the small Victrola into a handsome cabinet type.

Protects machine and records from dust.

Provides receptacles for new and used needles.

Places a genuine VICTROLA with the cabinet type effect into the hands of the user at a price less than is usually charged for cabinet machines of unknown make.

**Place Your Order Promptly
Through Your Wholesaler**



Setting Victrola into Cabinet

Sound Doors Open for Playing

Converto Wholesale Distributors

- | | | | |
|----------------------|----------------------------------|-----------------------|------------------------------|
| Austin, Tex..... | The Talking Machine Co. of Texas | Milwaukee, Wis..... | Badger Talking Machine Co. |
| Baltimore, Md..... | Cohen & Hughes | Mobile, Ala..... | Reynolds Music House. |
| | E. F. Droop & Sons Co. | Newark, N. J..... | Price Talking Machine Co. |
| Birmingham, Ala..... | Talking Machine Co | New York, N. Y..... | Emanuel Blout |
| Boston, Mass..... | Oliver Ditson Co. | | I. Davega, Jr., Inc. |
| | The Eastern Talking Machine Co. | Omaha, Neb..... | S. B. Davega Co. |
| Brooklyn, N. Y..... | American Talking Machine Co. | | Mickel Bros. Co. |
| Buffalo, N. Y..... | W. D. & C. N. Andrews. | Peoria, Ill..... | Putnam-Page Co., Inc. |
| Burlington, Vt..... | American Phonograph Co. | Philadelphia, Pa..... | The George D. Ornstein Co. |
| Butte, Mont..... | Orton Bros. | | Penn Phonograph Co., Inc. |
| Chicago, Ill..... | Lyon & Healy | Pittsburgh, Pa..... | H. A. Weymann & Son, Inc. |
| Cincinnati, O..... | The Rudolph Wurlitzer Co. | | W. F. Frederick Piano Co. |
| Cleveland, O..... | The Collister & Sayle Co. | | C. C. Mellor Co., Ltd. |
| Columbus, O..... | The Perry B. Whitsit Co. | | Standard Talking Machine Co. |
| Dallas, Tex..... | Sanger Bros. | Richmond, Va..... | The Corley Co., Inc. |
| Denver, Colo..... | The Knight-Campbell Music Co. | | W. D. Moses & Co. |
| Elmira, N. Y..... | Elmira Arms Co. | St. Paul, Minn..... | W. J. Dyer & Bro. |
| El Paso, Tex..... | J. W. Walz Co. | Syracuse, N. Y..... | W. D. Andrews Co. |
| Kansas City, Mo..... | J. W. Jenkins' Sons Music Co. | Toledo, O..... | The Whitney & Currier Co. |
| | Schmelzer Arms Co. | Washington, D. C..... | Cohen & Hughes |
| Memphis, Tenn..... | O. K. Houck Piano Co. | | E. F. Droop & Sons Co. |

DETROIT'S BEST YEAR WERE IT NOT FOR STOCK SHORTAGE

Good Reports From All Sides—Campaigns for Early Holiday Buying—Visits of Artists Help Record Sales—Hudson Co.'s Talk-O-Gram Service—The Month's Interesting Budget of News

DETROIT, MICH., November 6.—Only a shortage in the production of talking machines stands in the way of making this the best year for the dealers. This statement is made after careful interviews gathered from the leading men in the industry in Detroit and throughout the State. It is also true that piano dealers are enjoying good business, but nothing as compared to the talking machine dealers. It has been a fight with dealers to secure enough stock, both machines and records, but it has been a fight worth while because the people have certainly taken to talking machine products as never before in their history.

Under the auspices of the Detroit Retail Merchants' Association a campaign has already started, urging people to buy early for the holidays and to carry home where they can do so, as well as to carry home parcels unwrapped. Quite a number of talking machine dealers have contributed to the fund. The campaign has already made good in co-operation with efforts along similar lines by the dealers. For instance, it is no uncommon sight to see people carrying new records in the envelopes unwrapped; dealers also report that during October they took deposits on more machines than ever before—and all were for holiday trade, people making deposits to assure getting them.

Grinnell Bros. and the J. L. Hudson Co. took an active part in the recent campaign to gather records for the soldiers. They made window displays of the records brought in and even sent after large quantities. At the Hudson talking machine shop old records thus received were first put through the cleaning process.

S. E. Clark, general manager of Grinnell Bros., says his company is short on talking machines as well as records, but that they are doing everything possible to get more stock. Grinnell Bros. are the only Michigan Victor

jobbers. Besides they have a talking machine department in all of their branch stores. At their main Detroit store nearly forty booths are given over to demonstrating records.

The visit to Detroit by Caruso in October stimulated the sale of his records very materially. His concert here was a tremendous success, thousands being turned away after every available inch of standing room was disposed of. On November 11 the noted Gallucuri is scheduled for a recital, and already we have noted a number of attractive window displays featuring her records.

The influenza epidemic, which hit Michigan for three weeks in October, resulted in many talking machine stores shortening their hours of business. The State Board of Health put the ban on amusements, public gatherings, etc., but this had a good effect on the sale of talking machine records, as people were at home more than ever. The State ban was removed on November 6.

Max Strasburg, 74 Library avenue, is winding up his best year. Mr. Strasburg has a large stock of machines, having prepared for the apparent shortage months and months ago. This has been ideal golf weather, and so Mr. Strasburg has been spending considerable time in the afternoons out on the links.

Wallace Brown has opened his fall advertising drive on Brunswick phonographs. Mr. Brown is having a big fall trade, and he has been driving home several excellent thoughts to his patrons. One is that "music at home is the best and most economical way to enjoy the evenings during the coming cold winter months." Another point he brings out is that the shortage is getting serious in phonographs, that prices will soon advance, and that now is the time to buy. We must give every credit to Mr. Brown for the timeliness of his advertising—it is not

the stereotyped which is so apparent in a great deal of talking machine and phonograph advertising.

William H. Goldblum, formerly manager of the Story & Clark Piano Co., is now manager of the music department at the People's Outfitting Co. He handles the Victrola and Stradivara in talking machines.

The J. L. Hudson Music Store is enjoying its customary good business in both machine and record departments. This institution handles the Victrola, the Sonora and Cheney lines of phonographs. Half of the first floor is exclusively for record sales.

The J. L. Hudson Co. has inaugurated the Talk-o-Gram Service on the mezzanine of its main store on Woodward avenue. There is a charge of 75 cents for four four-minute messages and the same number of replies, plus a 6-cent charge on each message for transmission. The records can be shipped to soldier boys at Camp Custer, and later the company plans to extend the service to other camps in the United States. This service is a feature of the Hudson Military Shop, and is operated in conjunction with the Dictaphone branch of the Columbia Graphophone Co.

R. B. Alling, manager of the Edison Shop and the Phonograph Co., of Detroit, is now at Camp Taylor, Louisville, Ky., in the Officers' Training School. During his absence Frank Faul will look after his interests in the above companies.

Letter received by The World correspondent indicates that Private Peter C. Sweeney is now with Battery A, 328th Field Artillery, American Expeditionary Forces, somewhere in France. Mr. Sweeney was for three years connected with the Edison Shop of Detroit, as manager of retail sales.

J. Henry Ling, of the Ling Piano House, who handles the Columbia line, is showing samples to his trade of a replayer, which he will soon put on the market. It is Mr. Ling's own invention.

The Grosse Pointe Furniture Co., Grosse Pointe, a suburb of Detroit, is using street cars

Tone must be the prime factor in a musical instrument

STRADIVARA

Art Phonograph

PATENTED

"KNOWN FOR TONE"

An instrument of such rare artistic Beauty in Design, Workmanship, and Tone that won first place by sheer Merit.

From \$60.00 to \$250.00 with substantial discounts on a strictly one-price policy, fully guaranteed.

Full advertising service, of course.

The Compton-Price Company, Ltd.

Coshocton, Ohio

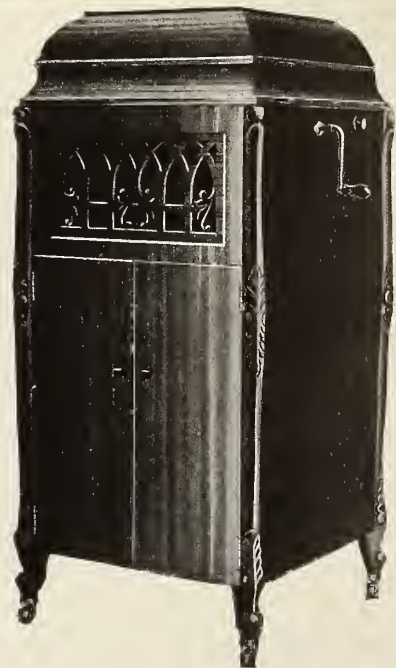

No. 200

to boost the Edison line, which it handles exclusively in that millionaire residential section.

A number of jobbers for various lines of talking machines declare that business is good, and that right now they are not as anxious to put on everybody without first conducting a rigid investigation relative to credits. "It's no trouble to sell your goods if you can get what the customer wants," is their contention.

Wallace Brown is now handling the Emerson records, featuring them at 65 cents.

During the month of October, through the co-operation of the Phonograph Co., of Detroit, quite a number of recitals were given in Detroit and through the State by Glen Ellison, baritone, for the Thomas A. Edison Co., Inc., the purpose being to create new interest in the Edison phonograph. In Detroit three recitals were given before large crowds at churches and at the Masonic Temple, under the auspices of Frank A. Bayley, of Bayley's Music House, and R. B. Alling, of the Edison Shop. Some of the dates set for the recitals through the State had to be canceled on account of the ban on public gatherings due to the influenza. However, a series of these concerts will no doubt be given during November now that the ban is removed.

EXPLOITING DECALCOMANIE

Samples and Information Regarding That Product Being Sent to the Trade

The Globe Decalcomanie Co., Jersey City, N. J., are sending out to the trade a new pamphlet showing the number of samples of their products. Prices of various quantities of name plates are also included, as well as an untransferred sample, which can be used in an actual demonstration. In speaking of business conditions affecting their industry this season one of the officers of the above firm recently said: "The demand for decalcomanie products during the past few months has been quite heavy. Manufacturers, of course, always place their name upon their products and there are but few dealers today who have not taken advantage of the benefit a name plate gives them in keeping their business before the purchaser.

PATHE ARMY AND NAVY MODEL

The Pathé Frères Phonograph Co. was recently advised by the United States Government that its Army and Navy model had been selected for the U. S. S. "St. Francis," one of the new members of the United States Navy. This instrument was chosen after keen competition, and the Pathé Frères Co. is naturally gratified to learn that its Army and Navy model was the ultimate choice for this new United States warship.

The VIVITONE

Gives New Richness of Tone to Your Favorite Records

This Tone Controller is the 1919 wonder of the Talking Machine World.

Insert Vivitone in the needle post of the sound box. You will be delighted with the vivid, pure, vibrant tone that results.

Shut your eyes and you imagine you are hearing the living voice of the singer or the actual music of the instrument.

The Vivitone can be used with all phonographs that use either ordinary steel or Tungsten needles.

Each package contains four tubes, playing thousands of records. Retail for 50 cents per package.

Sample free to Dealers who write for proposition on their letter head.

Vivitone Controller Company

400, 401, 402 Bell Block, Cincinnati, O.

CONCENTRATE ON RECORD SELLING

The Development of Foreign Record Business Can Be Made Profitable—Timely Pointers

The shortage of records of what are termed the popular sort having practically forced many dealers to work more intensively on the selling of records of the standard sort now in stock or available, which in the past did not frequently receive their full share of attention, has also brought about a more general appreciation of the opportunities for developing business among the foreign element of the population.

Regarding the development of foreign record business, "The Voice of the Victor" for October says: "There's a reason why every dealer should handle a foreign record business; a reason that jingles merrily to the tune of a bag of silver dollars. Yes, there's money in it—more to-day than ever before, and unless you're afraid of the income tax you'll take our tip and get these catalogs in circulation.

"They'll bring the business all right, and it's mostly cash business. The foreigner is, as a rule, not prone to intrust his money to a bank. He prefers to hide it in a stocking and pay for what he buys when he buys it. And his stocking is just bursting out at toe and heel, and bulging all over with bills and silver, for it's wages that have advanced by leaps and bounds, and the foreigner is a wage-earner. But not all of the contents of his weekly envelope goes into the family bank. No; a good share of it is being distributed among different merchants for luxuries and comforts he has always cherished and could never before afford. If you're not getting a share of it, it's because you haven't told him of the hundreds of his native songs, marches and folk dances he can have on Victor records.

"So first find out what nationalities are included among the foreign population of your city, and then order catalogs in those languages. Get one into the home of every foreigner in town, for they're all music-lovers, especially of the music of their native land.

"Put yourself in the foreigner's shoes for a minute. Imagine you're in a strange land where you seldom if ever hear English spoken. As you're walking about the street you suddenly hear some such song as 'Carry Me Back to Old Virginny.' How would it affect you? You'd be pretty sure to stop and listen, and then—you'd find out the source of that familiar music. If you discovered that it was a record you wouldn't hesitate long to buy that record, and a Victrola, if you could afford to. The foreigners in your city would be affected the same way by hearing a song as typical of their country as 'Carry Me Back to Old Virginny' is of America, and, remember, they can afford to buy Victrolas and records.

"If one song is prized so highly by a stranger in a strange land, think what the effect will be upon the foreigner when he gets a catalog listing many such songs. Songs which recall happy memories; patriotic marches that make his blood course more merrily through his veins, and folk dances that bring back the nimbleness of youth to worn and tired bodies.

"Maybe you thought it was necessary to speak the different languages to deal with these people, but you don't. The ready reference labels are printed in English, and the Supplements in both English and the foreign language. Then, too, remember numerals look the same in all languages except Chinese, so the foreigner has merely to point to the number of the record to make his wants known."

Some interesting information then follows regarding the new and complete foreign record catalogs just issued in twelve languages.

A feature of the recent 37th anniversary sale at J. N. Adam & Co.'s store in Buffalo was the celebration of "Victrola week." "The real purpose of this event," said the company, "is to acquaint you with our fine Victrola headquarters."

What Qualities Do You Demand In A Cabinet?



Harponola

Appearance?
Individuality?
Finish?
Strength?

THE CELINA CABINET has all these qualities. It is a cabinet the excellence of which is readily recognized. Made by furniture specialists. That is why it stands out from others.

Use the CELINA cabinet and make your line distinctive. They come equipped or unequipped. A special proposition for dealer, jobber or manufacturer.

We will be glad to send you all information

CELINA FURNITURE Co.
CELINA OHIO

TO THESE, WE AND OUR COUNTRY GIVE HONOR AND THANKS

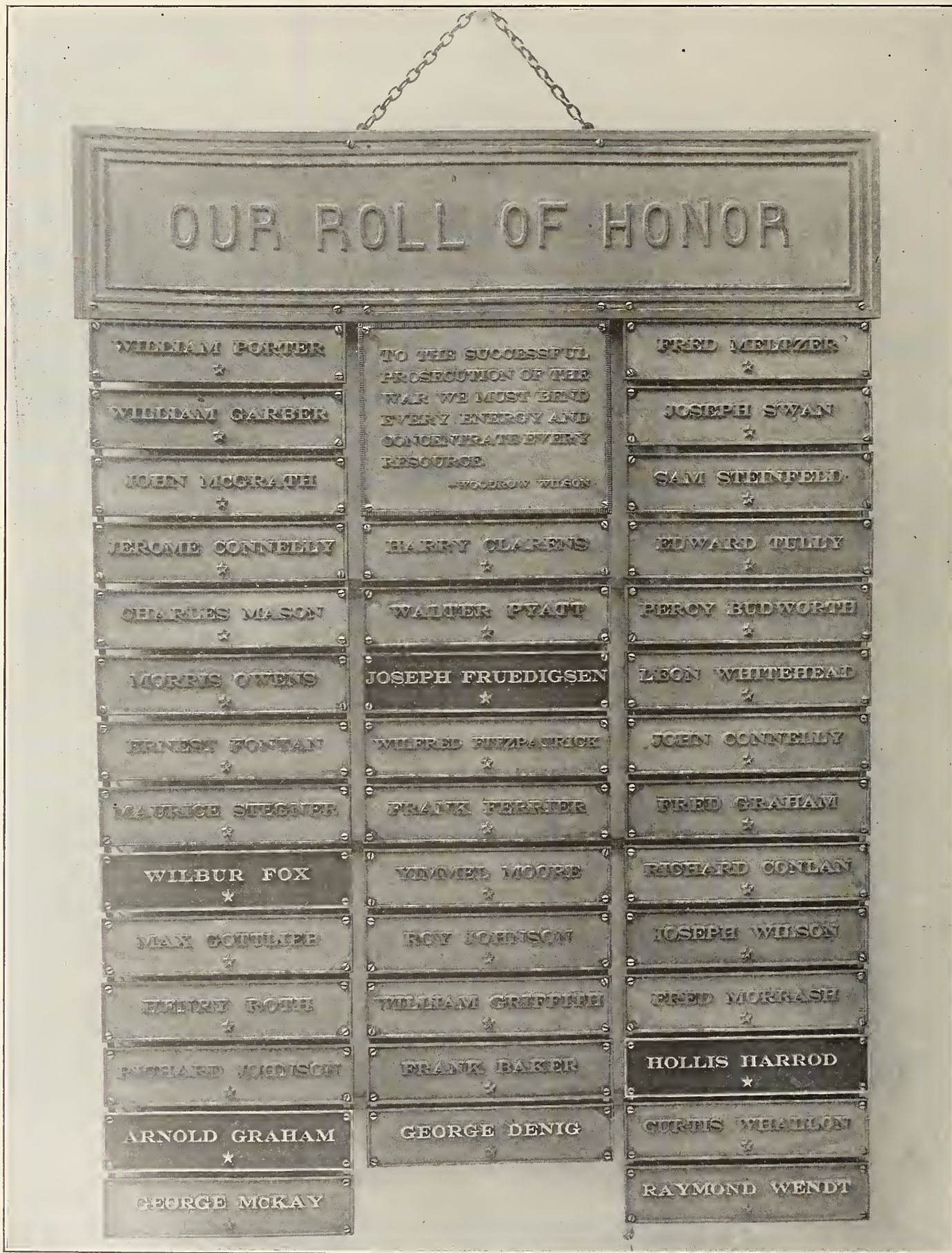

New York Talking Machine Company
 119 West Fortieth Street
 NEW YORK

Chicago Talking Machine Company
 12 North Michigan Avenue
 CHICAGO

FROM OUR CHICAGO HEADQUARTERS

E. P. VAN HARLINGEN,
Manager

World Office
Republic Bldg., 209 South State St., Chicago
Telephone: Wabash 5774

CHICAGO, ILL., November 8.—Much activity is seen this month throughout the wholesale trade of Chicago due to the final spurt in making preparations for the rapidly approaching holiday season. Many instruments have been manufactured during the past few months and set aside in anticipation of a heavy demand. The demand is now beginning and nearly all manufacturers are prepared to deliver the goods. Some of them were very fortunate in anticipating the new curtailment, which only permits the making of six models. These particular manufacturers had been industriously working to get down their models to no more than six types, and so were in a measure prepared for the curtailment order, which went into effect October 28. Some of them formerly had as high as a dozen types of instruments, but somehow or other they got the idea into their heads that an entirely new line containing only six models would be permitted and they had worked accordingly. They are now having no difficulty in complying with the Government's request. It is the general opinion that the new order will bring wonderful results in the talking machine industry.

For instance, consider the matter of finish. Formerly it has been the custom to have perhaps half a dozen different finishes, the object being to satisfy a trade that wanted to match instruments up with parlor curtains, portraits, etc. The new order, however, permits the use of but three finishes, mahogany, oak and fumed oak. The mahogany must either be red or brown, but not both. This in itself will go far towards saving necessary coloring material.

The record situation is slightly improved. The greatest change of all is announced in the December advance list of the Victor Co. This company has issued a notice that in lieu of the usual list of monthly records they are pressing an especially selected list of best sellers. It is, however, expected by the majority of the wholesale record men that even though their monthly receipts are larger they will not be able to fill the demand which they expect to be made upon them during the next two months.

The retail trade is moving nicely, and these men are in a fair way to take care of their demands for both instruments, records and accessories. Many of the retail dealers who former-

ly paid no attention to accessories, such as needle cutters, electric lights, etc., have wakened to the fact that there is money to be made by handling such parts, and have been laying in a supply of them. The popular patriotic records are still leading features.

Establish New Empire Agency

J. H. Stiff, of Atlanta, Ga., has been appointed Southeastern representative for the Empire Talking Machine Co., and will look after the States of Georgia, Louisiana and Alabama.

Representative Stiff writes the Empire Co. that there is a constantly growing demand for both the Empire talking machines and the Empire records throughout that territory. This is confirmed by the Empire Co. from the numerous inquiries which they have received from that section. Mr. Stiff is a man of high standing throughout his territory and has had long experience in the wholesale phonograph and piano business. He recently received his first shipment of Empire samples, and in writing to the company acknowledging receipt said that he was greatly pleased with both the instruments and the records, and that they have more than fulfilled his expectations. Since his appointment as Southeastern representative of the Empire Co. Mr. Stiff has closed quite a number of new deals for the Empire black-faced records.

Six Best Sellers

The Victor Co. announce the six best sellers for the month as follows: "La Ronde des Lutins" (Dance of the Goblins), "Love's Garden of Roses"; "A Dream of Love" and "Madame Butterfly"; "Oriental" and "Dodola"; "For Your Boy and My Boy" and "When You Come Back"; "When You Sang 'Hush-a-Bye Baby' to Me."

The Columbia Co. offer the following six best sellers: "De Molay Commandery March" and "Invercargill"; "Indianola" and "Oh, You La! La!"; "Everything Is Peaches Down in Georgia" and "You're in Style When You're Wearing a Smile"; "How I Hate to Get Up in the Morning" and "Let's Bury the Hatchet"; "The Yanks Are at It Again" and "We Don't Want the Bacon"; "Pickaninnies' Paradise" and "Everything Is Peaches Down in Georgia."

The six best sellers announced by Pathé for the month are: "Beale Street Blues" and "The

Weary Blues"; "Then You'll Remember Me," from "Bohemian Girl" and "Serenade"; "For-Your Boy and My Boy" and "Freedom for All Forever"; "You'll Always Find a Lot of Sunshine in My Old Kentucky Home" and "After You've Gone"; "Rock-a-Bye Baby" and Witmark's "Hit Medley"; "Hindustan" and "Frivility."

The six best Edison sellers for the month are: "Just Like Washington Crossed the Delaware, General Pershing Will Cross the Rhine" and "Makin's of the U. S. A."; "Indianola" and "Down in Jungleland"; "Dixieland Memories, No. 1" and "Dixieland Memories, No. 2"; "Rigoletto Selections, Part 1" and "Rigoletto Selections, Part 2"; "I'll Think of You—the Rainbow Girl" and "Rainbow Girl Fox-Trot"; "Zampa Overture," 1 and 2.

The six best Emerson sellers for the month are: "When You Come Back and You Will Come Back" and "When I Get Out in No Man's Land, I Can Be Bothered With No Mule"; "Oh, How I Hate to Get Up in the Morning" and "Our Country's in It Now, We've Got to Win It Now"; "When I Send You a Picture of Berlin" and "Oh, Frenchy"; "I'm Sorry I Made You Cry" and "I'm Always Chasing Rainbows"; "General Pershing" and "April Smiles"; "Smiles" and "Since I Met Wonderful You."

The latest offerings of the Okeh library are: "Sing, Ling, Ting" and "Oh, Lady"; "Alimony Blues" and "Three Pickaninnies"; "National Emblem March" and "Naval Reserve March"; "Keep the Home Fires Burning" and "There's a Long, Long Trail"; "Hearts of the World" and "When You Come Back"; "Good-bye, Alexander" and "Mammy's Chocolate Soldier."

Columbia Gleanings

W. C. Fuhri, manager of the Chicago branch of the Columbia Graphophone Co., in reviewing the status of the Western trade for the month of October stated: "The business transacted was the greatest in our history. The tendency is towards higher-priced models in machines, while the popular records continue to be the leaders. We are in excellent shape to take care of the holiday business."

The Chicago branch of the Columbia Co. has recently installed a new department, known as the city order department, which is in charge of

(Continued on page 73)

NEW PRICES ON THE "WADE" FIBRE NEEDLE CUTTER

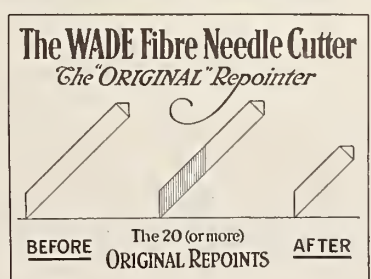

Write for samples and Trade Discounts
or Order from your regular Distributor

WADE & WADE, 3807 Lake Park Ave., Chicago, Ill.



This 24-sheet poster now ready for distribution. Ask for prices.

Every Woman wants a Victrola, but does she know that yours is the best place to get it?

- ☞ A store is judged by its advertising just as a person is judged by his clothes.
- ☞ Half the battle is won by "dressing" your advertisements attractively. This you can accomplish with the aid of the services we provide.
- ☞ Just one sale will pay the cost of any of these services for a year.

Lyon & Healy Victrola Advertising

Victrola Newspaper Advertising Service consists of one Victrola advertisement each week, including matrix of the illustrations, proof sheet and copy. Price \$8.33 per month.

Victrola Newspaper Advertising Half Service consists of 26 advertisements per year, complete, at \$4.17 per month.

Victrola Art Window Cards. Printed in colors; four per month, i. e., two 14x22 inches in size; two 11x14 inches in size. They feature the new Records, \$1.25 per month.

Victrola Art Covers. Use them instead of envelopes for mailing the monthly Victor supplement; beautifully printed in colors. Tell us how many you need; we will quote prices.

Victrola Galli-Curci, 24-sheet Posters. Lithographed in colors with name strip, \$2.30 each in lots of five or more. Specify quantity.

Victrola Record Fairy, 24-sheet Poster, \$2.30 each in lots of five or more. Specify quantity.

Victor Record and Knitting Bags. Made of Kraft paper with string handles, 12c each in lots of 100 or more. Specify quantity.

Small Instruments Newspaper Advertising Service, thirty-six illustrations per year, \$4.17 per month.

Piano Newspaper Advertising Service. Forty-eight illustrations per year, free to Lyon & Healy dealers.

Soldier Song Books. Featuring the latest patriotic songs, 2c each; a splendid advertising novelty. Specify quantity.

TEAR OFF HERE

No charge for this Record Fairy Cut-out. We will send six of these 50c. cut-outs with each order for our advertising services received this month. Lithographed in full color, size 12x10.

Messrs. Lyon & Healy,
Chicago.

Please send me the _____
_____ service and 6 cut-outs.
My name is _____

My address is _____



LYON & HEALY

Victrola Distributors

CHICAGO

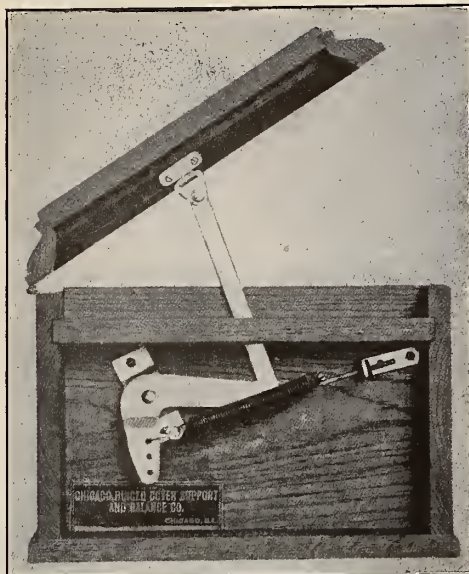

(Pat. Applied For) COVER BALANCE No. 1

Wherever You Go

You are sure to find a dealer somewhere selling a talking machine "without a kick." His business is growing steadily. Why? If you investigate the instruments he handles you will find they are rightly *Equipped*. That's what counts! *Equipment*. Look over your machine's *Equipment* a second time and then just remember that

The Chicago Cover Balance Number 1

is one equipment feature that builds a dealer's business. Can your dealers say they are selling talking machines "without a kick"? If not, write us at once and we will help put your machines on the market—"Kickless."

The cover is "PUT" and "STAYS PUT"

WE ALSO MANUFACTURE CONTINUOUS AND GRAND TOP HINGES

Chicago Hinged Cover Support and Balance Co. 2242-44 W. 69th Street CHICAGO, ILLINOIS

FROM OUR CHICAGO HEADQUARTERS—(Continued from page 71)

G. I. Stanton. It is entirely separate from all the other departments in the Chicago branch, such as country business, etc., the idea being quick and efficient service for those who call personally for their orders.

Frank Dorian, of the New York executive offices of the Columbia Co., passed through Chicago recently on his way to Seattle. He was accompanied by his family and in future will make his home in that city.

A. G. Decker, manager of the trade promotion department of the Columbia Chicago branch, announced the arrival of a young lady at his home the other day.

Miss Florence Bell, who was formerly W. C. Fuhri's secretary, has arrived safely in France with the Red Cross contingent. Her place in the Chicago branch is being occupied by her sister, Bessie.

Happenings at the C. T. M. Co.

L. F. Geissler, general manager of the Victor Co., and R. J. Keith, vice-president of the Chicago and New York Talking Machine Cos., passed through Chicago a few days ago en route to the East from a week's hunting trip in Canada. Both gentlemen had a lively time during the hunt and managed to bag a number of fine ducks. Mr. Keith stated that there were eleven varieties of ducks in their bag.

Walter Geissler, assistant credit manager for the Chicago Talking Machine Co., received a wire from his brother, E. A. Geissler, general manager for the Geo. J. Birkel Co., Los Angeles, that the latter's son, Ted, had died of pneumonia several days ago.

Corporal Emmett O'Connell, who was formerly connected with the record department of the Chicago Talking Machine Co., was reported killed in action during activities in the St. Mihiel salient.

Mastered a Difficult Problem

The Chicago Talking Machine Co. showed

some wonderful speed and ingenuity in getting out of a perplexing predicament recently caused by the delay of their November shipments of records. The records were several days late and for a while no trace could be found of the cars. However, after much long distance telephoning, the shipment was located on a car repair track at Ft. Wayne, Ind. After much wrangling with the railroad company the shipment was finally moved as far as the Burnside Yards. This was on the night of October 31, and the records were to be on sale the following day. It was then that D. A. Creed's ingenuity came to the front. He got off a dozen or more large motor trucks and with the caravan made a quick ride of about thirty miles to the Burnside Yards. The train was already hooked up and waiting orders to pull into Chicago. Mr. Creed located the cars that contained his shipments, backed his trucks up to them, unloaded them and sped back to the Chicago warerooms. Everyone in the office worked all night sorting the records, and at about 8 o'clock the next morning the same were delivered and on sale.

Wade & Wade Announce New Prices

Wade & Wade, manufacturers of the well-known Wade fibre needle cutters, announce their new prices, which went into effect November 1. They are \$2 retail for No. 1 and \$2.50 retail for the No. 2 Wade cutter.

New Wilson Manager

Philip S. Ridgway, for many years connected with the Victor department of Sherman, Clay & Co., in San Francisco, and for the past two years manager of the Victor department of the Cable Company, is now manager of the phonograph department of Thos. E. Wilson & Co., succeeding the late Arthur L. Spring. Mr. Ridgway has wide experience in both the wholesale and retail branches of the trade. He is thoroughly conversant as regards the manufac-

turing of talking machines and is therefore a valuable asset for the Wilson house.

Now General Manager of Fulton-Alden Co.

John R. Fulton, whose photograph is reproduced herewith, has just resigned as cashier of the People's Bank of Waukegan, Ill., of which he was the organizer and a heavy stockholder,



John R. Fulton

to become general manager of the Fulton-Alden Co., of that city, manufacturers of the Fulton talking machine. Mr. Fulton organized the People's Bank in 1900, prior to which time he had been connected with the First National Bank for ten years. He has been associated as a stockholder with the Fulton-Alden Co. for some time, and he has been naturally in close touch

(Continued on page 75)

TRANSFER NAME-PLATES

We make the Transfer Name-Plates and Trade-Marks for the largest talking machine manufacturers in this country and for dealers in every state.

YOUR NAME, Mr. Dealer, on every machine brings the owner back to you for records and his friends to you for a machine.

Samples, Suggestions and Sketches Furnished Free

THE MEYERCORD COMPANY, CHICAGO

Largest Manufacturers of **DECALCOMANIA** Transfer Name-Plates

Two Great Selling Features Every Brunswick Dealer Appreciates

1

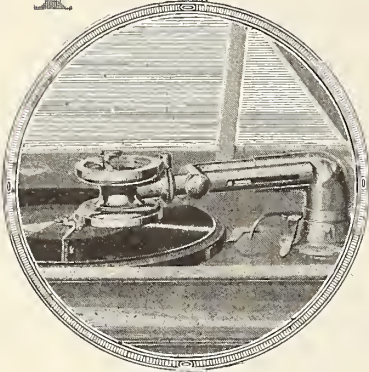

The Ultona—
a unique feature of The Brunswick Method of Reproduction. Now you can play all makes of records at their best.

THE Brunswick Method of Reproduction has brought about an increased volume of sales. Dealers everywhere join in praising this great idea.

Most dealers realize the drawbacks to old methods of reproduction, and the public, in becoming acquainted with The Brunswick Method, is losing interest in yesterday's standards.

The House of Brunswick is educating the music-loving public to make comparisons. In its advertising in national publications The House of Brunswick is stating compelling facts—which few purchasers care to ignore.

The current advertising campaign spotlights two

features of The Brunswick Method of Reproduction: [1] The Ultona and [2] The Brunswick Amplifier.

A description of the Ultona is enough to make the average buyer anxious to see this new all-record player.

In speaking of The Brunswick Tone Amplifier, we state how The Brunswick attains superior reproduction by complying with acoustic laws, and how we avoid old conceptions.

By studying our advertising, you will note that it is pure selling copy, the exact arguments you and your salespeople can use to great advantage. It is straight from the shoulder, and presents compelling REASONS WHY.



The **Brunswick**
ALL PHONOGRAPHS IN ONE

2

This super-phonograph, as hundreds of Brunswick Dealers will attest, has won high rank as a profit and friend-maker. And its popularity is ever increasing.

We are proud of its reception and of the fine dealer connections it has brought to The House of Brunswick. We have placed our faith and

our resources behind this phonograph and we know that an even greater future is attainable.

More and more The Brunswick is winning friends—everyone who hears it recognizes its worth. We intend to increase this appreciation of The Brunswick—and every Brunswick Dealer will profit thereby.



The Brunswick Amplifier

a new idea in tone reproduction, departing from old-time crudities. Tones hitherto lost are now brought out in rich clarity.

The Brunswick-Balke-Collender Company

Branch Houses in Principal Cities of United States, Mexico and Canada

General Offices: Chicago and New York.

Canadian Distributors Musical Merchandise Sales Co. Excelsior Life Building Toronto

FROM OUR CHICAGO HEADQUARTERS—(Continued from page 73)

with his brother, Robert Fulton, president of the company, and has seen the development of the Fulton machine with its fundamental vibratory horn. He will very easily adapt his broad business knowledge to the organization of which he is now an executive.

As the readers of The World already know, the company recently purchased the business of the Metal Specialties Co., of Benton Harbor, Mich., manufacturers of motors, and W. R. Everett, who founded that concern, will be the superintendent of the Fulton industry. The company are also preparing to make their own sound box, of which great tonal merit is claimed, and of a new cover support. A week ago the company established a Chicago office at rooms 309 and 311, 20 East Jackson boulevard. President Robert Fulton will be in personal charge of the office. While, of course, a full line of the company's machines will be on exhibit and he will always be glad to meet visiting dealers, he will devote a great deal of time to marketing the company's motors, sound boxes and cover supports with other manufacturers of talking machines.

Secure Protection of Console Type of Machine

A great deal of interest has naturally been created in the trade by the announcement in last month's World that the Windsor Furniture Co., of this city, has been granted a patent on what

ment. This they did to a remarkable degree, but it is not surprising that the case was sacrificed in some degree to the instrument. The second development of importance was the departure from the old external horn type to the cabinet type of machine, in which the horn was made an integral part of the cabinet and took the function of a tone chamber beneath the operating parts of the machine. It was some time before any material change in type of cabinet was made, but in the meantime the furnishing of homes of comparative wealth and refinement had undergone a distinct change, and the various period types had developed. Naturally this company, which was primarily a furniture manufacturing concern, was in touch with these changing modes.

"We produced the first cabinet without the slightest intention on our part of going into the business in a commercial way. My mother had a machine in her home, and one day asked me if I couldn't make a new cabinet for it so that it would harmonize with the Louis XVI style of furniture in her living room. I got working on the idea, and, as a result, we built our first console type, which was the progenitor of this type in the talking machine field. It is a very logical development. The console is, of course, in no sense a table. It is primarily an ornamental piece of furniture, intended to stand

against the wall. Its utility as a container for magazines, bric-a-brac and what not is only secondary. It occurred to me that by introducing the console type of talking machine it would simply fit in beautifully in the decorative scheme of a room and thus avoid the introduction of another piece of furniture. That in short was the genesis of the idea with us, and it was not long before we approached a few of our customers who had been buying art furniture from us for many years. People like the

Tobey Furniture Co., of Chicago, grasped the idea eagerly, and the popularity of this type has steadily grown. Of course, there will always be a large demand for the upright machines, but it is very apparent that the demand for the console type of machine is rapidly growing among those who can afford to furnish their homes in the most artistic manner."

Start Window Dressing Contest

The Talking Machine Shop of Chicago is noted for original methods of attracting business. One of the latest stunts is to inaugurate a window trimming contest. They have inserted in the local daily papers a pen drawing of their building and announce that they will pay \$200 for the best suggestions as to how to

trim their main show window. The prizes are divided into five lots, the first being a \$100 Liberty Bond, the second a \$50 bond, the third being \$25 in War Savings Stamps, the fourth \$15, and the fifth \$10.

It was also announced that this unique and straight-forward proposition is open to everyone except to employes of the Victor Co. and the Talking Machine Shop.

They request in their ad that their regular form of rules be applied for. The rules are then sent out printed on a large sheet of paper containing space for applicant's name and address, etc., and numerous lines to guide the writer in making his suggestion.

Of course the main idea of this contest is to get prospects for the sale of talking machines. Therefore a small blank is attached to the end of the paper on which it is suggested that if the contestant knows of anyone who is considering buying a Victrola, will he or she please mention their names and addresses on the blank.

The list of prospects already received by the Talking Machine Shop is amazingly large.

The "Self-Service Record Cabinet"

Another new business-getting idea is the recent installation of what is known as a "self-service record cabinet." This is a cabinet containing sixty-three compartments, each compartment measuring three inches wide by twelve high and twelve deep. The total length of the cabinet is approximately sixteen feet.

The purpose is twofold. The first is that records of which there is a plentiful supply can be placed in the cabinet. The customer is at liberty to make his own choice without waiting for the attendant and he may then go back to the demonstration room and try it over for himself. In this way much time is saved, the purchaser selects more freely and is apt to purchase proportionately.

Again this "self-service cabinet" comes into good effect in the following manner. At times, in this store, as in all stores, more customers come in than can be taken care of by the salesladies. The saleslady cannot wait on more than one at a time, whilst the customers are in a hurry to make their purchases and leave. As is well known in cases of this kind, the impatient customer will generally walk out without waiting his turn. There the "self-service cabinet" comes to the rescue, the purchaser takes advantage of the liberties offered him and goes down the line of records, chooses the one he wants and takes it to the wrapping counter himself.

Over each compartment of the container there is a little sign telling the price and names of the selections on both faces. The results obtained during the three weeks or more that this cabinet has been in service have more than paid for its cost.

The Victor Co., it is said by C. L. Davidson, (Continued on page 77)



The Windsor Harmonizing With Surroundings

is known as the console type of cabinet talking machine, covering the location of the record file alongside of the machine itself. It is, according to H. C. Moyer, president of the Windsor Furniture Co., the first mechanical patent granted on a talking machine cabinet. The patent was applied for something over three years ago and was finally allowed on September 24 of this year.

"To my mind the development of the console type of machine marks a distinct step in the progress of the talking machine industry," said Mr. Moyer. "As I understand it, for very many years the whole effort by the three great firms who are the originators of the industry was to develop the machine itself as a musical instru-



UNIVERSAL TONE ARM



NO SPRINGS
NOR WEIGHTS
TO ADJUST

MADE IN
FOUR
LENGTHS

Patent Applied For

Talking machine manufacturers should anticipate their tone arm needs early to insure prompt delivery. The demand for phonographs this Fall will be very large, and it is the manufacturer who places his order early that will be given the benefit of Empire service. Get in touch with us at once and secure our quantity prices on this splendid equipment.

Address all inquiries to Chicago Office

PLAYS ALL
MAKES
OF RECORDS
PERFECTLY

WRITE
US FOR
PRICES



THE EMPIRE PHONO PARTS COMPANY

Sales Office: 425 SO. WABASH AVE., CHICAGO, ILL.
Factory: 1100-1108 W. 9th STREET, CLEVELAND, OHIO

A Great Sales Power

FOR EVERY

PHONOGRAPH DEALER

Every Hiawatha you sell means more sales.

They act as an endless chain.

Honest merchandise can always repeat.

Every Hiawatha Phonograph can be sold with your

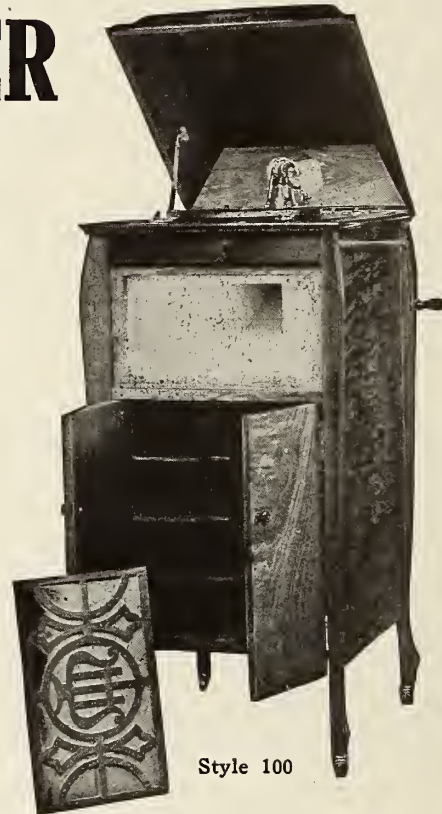

Style 100

stamp of approval and backed up with your business reputation.

Prepare for your Fall business.



FIVE HIAWATHA MODELS: \$50, \$75, \$95, \$125 and \$175

IMMEDIATE DELIVERY

Hiawatha Phonograph Company

209 South State Street

CHICAGO, ILL.

FROM OUR CHICAGO HEADQUARTERS—(Continued from page 75)

were very much impressed by this cabinet and took the trouble to send one of their representatives to the Talking Machine Shop to find out just how it worked.

Vitanola Co.'s Activities

As may be seen elsewhere in this paper the Vitanola Co. is formally announcing to the trade that in compliance with the conservation request of the Government it is limiting itself to six models, five cabinet machines and one art model.

S. S. Schiff, general manager of the company, has made several announcements as to this new line during the past four months, as he had convinced himself that a new curtailment order would limit the number of designs to be manufactured by any company. He believes that he is very fortunate in anticipating the Government's desire. For the past four months the Vitanola Co. have been working along with their new models, and have a plentiful supply on hand to take care of their trade. The models sent out up to the date of curtailment were only the six that had been manufactured previously. The six models being offered at present are entirely new in design and construction. Methods of conservation of material have been followed in their construction to a maximum and a large stock has been accumulated in preparation for the Christmas trade. All of the old styles are now discontinued.

During the past few months Manager Schiff has been ceaselessly toiling for the benefit of Vitanola dealers. In fact, he has been working so hard that he has gained the soubriquet "double service," due to his initials S. S., from his associates. If he hears of a new idea being employed by some dealer, he goes over it thoroughly and gives it an acid test, determines its merits, and then sits down and gets out a circular letter making it known to all Vitanola dealers. He has done much good for Vitanola dealers by circularizing their territory for them, writing up ads for their local newspapers, and, in fact, doing everything possible to help them get business. He has recently made a contract with a national bill posting concern and has laid out copy for a new twenty-four sheet poster. These posters will be employed in vicinities adjacent to Vitanola dealers' warerooms.

A Timely Talk on a Timely Topic

G. C. Fricke, vice-president of the Lakeside Supply Co., believes that legitimate talking machine dealers are seriously hampered in their work by warehouses and auctioneers, who get hold of a cheap machine of flashy design, equipped with extra cheap motor and tone arm, a machine that will sell from appearances only, rather than quality. "We are constantly receiv-

ing requests," said Mr. Fricke, "for repairs and repair parts of motors and tone arms for these mushroom machines, especially those placed on the market by dealers whose only object is to get hold of a few customers, make some sales and forget whether the trade suffers or not. Some of these motors and tone arms are brought in by people who want them repaired. Actually a legitimate dealer would be ashamed to offer such stuff to the public even as equipment of a \$10 machine. Nevertheless, these dealers are getting prices similar to those being asked for the best make of machines. Whenever we get a request for these type of motors or tone arms from some new company we always turn them down, and we also turn down requests for repairs on these parts.

"We believe that an association of jobbers should be formed with a central office, and then whenever a jobber receives a request for these cheap parts from any manufacturer the name and address of that company should be turned over to the association and its members warned not to have anything to do with them. The sole object of such people is quick money. We know of instances where these fellows go from town to town, start up under new names, get a lot of goods on thirty days and then disappear, leaving a bunch of cheap machines in their wake and a bunch of sorrowful purchasers as owners.

"The time is ripe now for manufacturers and jobbers to get together and form an association for mutual protection. These mushroom companies show themselves time and time again to be skips and bill evaders, and if record were kept of them it would not only protect the jobbers and manufacturers, but would prove of great benefit to the small company that is just starting up."

Mr. Fricke made the announcement this week that his company has made a fortunate purchase of three thousand Stewart phonographs. These instruments have been made since July 1, and the Stewart Co. asserts, according to Mr. Fricke, that they are the only ones that will be made by that company until after the war.

Pseudo Soldier Arrested

According to an item which recently appeared in the Chicago Examiner, Robert Nicholson, formerly connected with the Cleartone Phonograph Co., 327 South LaSalle street, was turned over to the Federal authorities charged with posing as a soldier. Incidentally, he is said to have admitted the theft of several phonographs from the Cleartone Co. Nicholson is quoted as leaving his position a few days previous to his arrest. He was followed by detectives when

it was learned he had sold one of the Cleartone instruments that he appropriated. The detectives later found him at the home of one of the waitresses, Mrs. Helen Tracy, where he was enjoying a selection being played on one of the missing instruments. Nicholson had told the woman that he was a veteran of both the Philippine and Mexican campaigns and proudly pointed to a number of medals he was wearing. Later he confessed that he bought these medals for ten cents each.

J. B. Schiff in Service of United States

The trade of Chicago has once more asserted its patriotism and has given another of its well-known members to the service of Uncle Sam. The latest recruit is Jeffrey B. Schiff, who was



Jeffrey B. Schiff

called to the colors on Tuesday, October 29. About four months ago Mr. Schiff enlisted in the U. S. Naval Forces and made application for entrance to the Ensign Naval Training School on the Municipal Pier, Chicago. He was formally notified on Tuesday to present himself at the Great Lakes Naval Training Station and begin a three weeks' term of detention. His first day in detention brought him, as he states, under terrific bombardment. The first attack was from a hypodermic needle, as usual, and then as soon as he got out of the surgeon's office he was sent to the Quartermaster's Department. As he was walking along he was hit with a mattress. He picked the mattress up, as per instructions he received from the donor,

(Continued on page 79)

We Distribute at Wholesale the OKEH RECORDS

Hill-and-dale cut. Double face, 10-inch size. Retail at 85c.

We Can Fill Your Orders

Monthly Bulletin Mailed Free for the Asking

Write Us Now!



A Full and Splendid Line of Patriotic Music, Popular Songs, Dance Hits, Musical Comedy, Grand Opera, Standard, Sacred.

GREAT ARTISTS!!

NOW READY

Magnola Talking Machine Company

General Offices
711 Milwaukee Avenue, Chicago

OTTO SCHULZ, President
CHICAGO

Southern Wholesale Branch
1530 Candler Bldg., Atlanta, Ga.

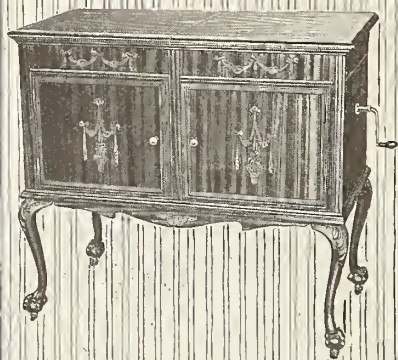

VITANOLA 17, \$300.00
Brown Mahogany

THE NEW LINE OF
VITANOLA
TALKING MACHINES



VITANOLA 12, \$160.00
Mahogany or Oak

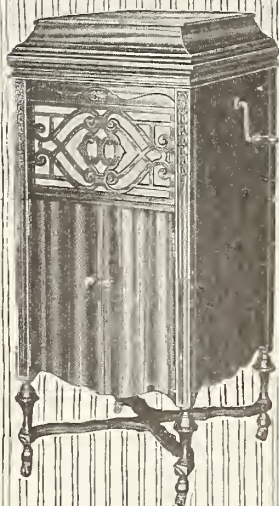

VITANOLA 16, \$200.00
Mahogany or Oak

Announcement

The Vitanola Company

announces the complete new line of Vitanolas—a new phase in the development of sound-reproducing instruments. New models, with many new and valuable improvements—and just in time for the holiday season.



VITANOLA 10, \$120.00
Mahogany or Oak



VITANOLA 14, \$180.00
Mahogany or Oak

The exquisitely designed cabinets, the enlarged and voluminous tone chamber, the improved motor, the new tone arm and sound box are all incorporated in our new models.

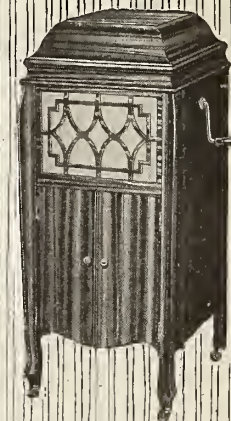

VITANOLA 8, \$90.00
Mahogany or Oak

Write for Prices and Terms

VITANOLA TALKING MACHINE CO.

501-509 W. 35th St.

Chicago, Ill.



FROM OUR CHICAGO HEADQUARTERS—(Continued from page 77)

and he went on a few feet further and was struck by a pair of navy brogans. He was continually bombarded for a half hour with various items of clothing and equipment and then assigned to his bunk. The latest reports show that he is getting along very nicely and is tickled to death with his new undertaking.

Mr. Schiff is a nephew of S. S. Schiff, general manager of the Vitanola Co., and M. C. Schiff, president of the company. Since his first connections with the Vitanola Co., shortly after his graduation from Notre Dame University in 1915, he became active with the Vitanola interests and was soon appointed secretary of that company. His work was of the highest caliber, for he is an excellent advertising man, as well as correspondent.

Helping the Dealer

"The traveling salesman who keeps tab on just what his dealers are doing is the fellow who can help his company in a large measure," said F. W. Clement, manager of the Chicago branch of the Emerson Phonograph Co. "He is continually confronted in calling on his dealers with problems as to why records are selling or why they are standing still, and it is up to him to spread the good news in one case and lend a helping hand in the other. If he calls on a dealer, and that dealer is making a phenomenal success with his records, it is an easy matter for him to go over the latter's plans and find out just how he is achieving that success. Then when he comes to the dealer who is practically standing still he can help tremendously by going over the situation and suggesting some of the plans of the successful dealer. In this manner he aids, not only the slow dealer, but his company and himself.

"For example, I will relate a case that may sound out of the ordinary to talking machine dealers," he continued. "Nevertheless it can be tried out very successfully in a small town and wonderful results can be obtained. One of our men reported how an Emerson dealer in a small town in Indiana, who was asleep on the job, woke up one day and began to sell records. This dealer had a very nice jewelry store and he carried a side line of talking machines and Emerson records. No one ever came into the place except an occasional man wanting a watch or a clock fixed, but they never bought records. The dealer looked out of his door one day and saw business going on in the other stores around him. The grocery store on the corner was busy and out on the front sidewalk they had a stand displaying their wares. The same case with the furniture dealer. His wares were also on the sidewalk. The dealer then looked around his own store and made the discovery that his talking machines and records were in the back part of the place, almost entirely hidden from view. A happy idea struck him. He took them out from the back and put a few machines on the sidewalk, with a record rack as well. One of the machines was started to work and soon there were several people around it listening to the music. The dealer then put the customary window hangers in his window, and soon the whole town was wise to the fact that they could buy talking machines and Emerson records in that store."

Seven Wilson Styles to Select From

The loss of A. L. Spring, whose sudden death was such a shock to the local trade, has been deeply deplored by the entire staff of Thos. E. Wilson & Co. But his successor, P. S. Ridgway, is setting out with a firm determination to carry on worthily the work so well begun by Mr. Spring. The Wilsonian phonograph line now includes seven models, and the company is in a position to fill all orders to a reasonable extent. In their advertising to the trade they are laying stress on the fact that the line is "backed by one of the world's great trademarks," meaning by this, of course, the famous "W" design of the Wilson house, which is so familiar throughout the Middle and Western sections of the country.

Fletcher Reproducer News

The Fletcher-Wickes Co., 6 East Lake street, find their principal trouble these days to be how to frame excuses for slow delivery to customers who wait impatiently. At the moment of writing we are informed that a release of some more steel has now been obtained and that many orders which have been held up for want of material can now be filled at once. Without discussing the special acoustical claims made for the Fletcher reproducer, it may be said candidly that the reproduction secured by its installation on various machines we have had the opportunity to hear is decidedly remarkable, especially in respect of bringing out low bass tones, in clarifying orchestral detail and in making piano accompaniments distinct and clean instead of muffled and half inaudible. The Fletcher constitutes, in fact, a definite advance in reproducer construction.

Woodard With Emerson

C. J. Woodard, one of the best-known wholesale representatives in the Chicago trade, is now associated with the Chicago branch of the Emerson Phonograph Co., and is looking after the territory comprised by Chicago and suburbs. Since his connection with the Emerson Co. Mr. Woodard has opened quite a number of new accounts throughout his territory, and Manager F. W. Clement is more than pleased with the results of his work. His most recent achievement has been securing the well-known piano firm of Julius Bauer & Co. as an Emerson account. This firm will handle the new 75-cent Emerson double-faced records.

Brunswick Shown at Fair

One of the most interesting and attractive booths at the recent County Fair held at Can-



Kenny Bros. Co.'s Exhibit
ton, Ohio, was that of the Kenny Brothers Co., of that city. The booth, as will be seen from (Continued on page 80)

"The Blackstone"

(CONCERT MODEL)

"The Talking Machine with a Silvery Voice"

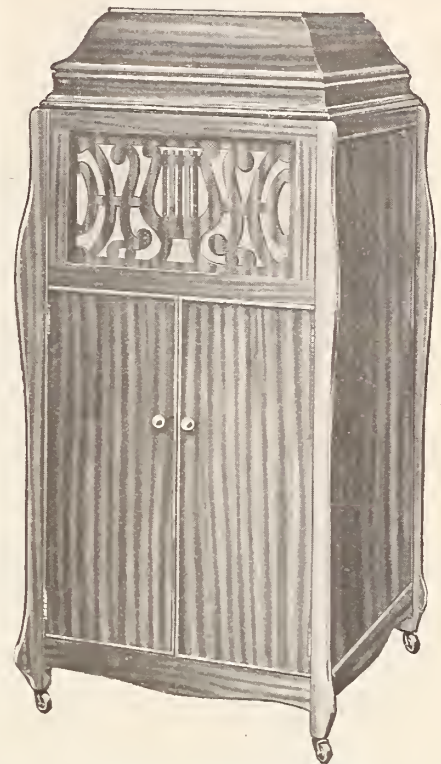

Retail Price, \$150.00

Specifications

Unusually large, massive and handsome Cabinet made from the finest selected foreign and domestic hardwoods; size, 50 inches high, 23 inches wide and 24 inches deep; finished in a genuine piano polish, mahogany only. Has finest double spring motor; universal tone arm; playing perfectly any disc record made. Equipped with the latest style tone amplifier and modifier. Special resonant sound chamber scientifically constructed on acoustic principles. Unusually large record filing space.

Unusually liberal discounts to dealers, thereby insuring unusually good profits. Write us for full particulars—also about our exclusive agency in your territory.

Jobbers Attention

We make special machines under your own name, on contracts of sufficient size, when desired.

GARVIN-BROWN CO.

2501-2503 N. Western Avenue, CHICAGO, ILL.

Cabinets—Cabinets—Cabinets

For dealers, wholesalers and jobbers or those who desire to sell their own brand, style and make of talking machines. Let us figure on what you desire. We are not too busy to build your cabinets.

Chas. Passow & Sons

2121 to 2141 ALLPORT STREET

CHICAGO, ILL.

We Have Purchased from the Stewart Manufacturing Corporation 3000 Stewart Model "C" Phonographs

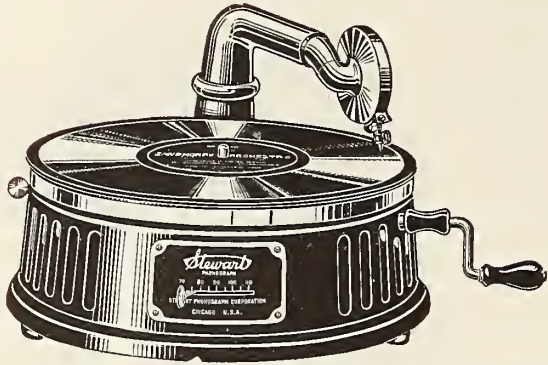

All these machines have been built since July 1, 1918, and so have all latest improvements including brass bearings on motor, ground shafts, cut gears, etc.

The retail prices are **\$8.50 east of the Rockies**; **\$9.00 west of the Rockies**; **\$9.50 in Canada** and **\$10.00 in Western Canada.** (Write for Wholesale Prices.)

Packed in individual cartons, 5 or 6 to a case

When present stock is exhausted no more of these machines will be available till after the war.

We can supply you with phonograph hardware, mica diaphragms, tone arms and motors. We maintain an expert repair department and can supply parts for nearly all types of motors and tone arms.

LAKESIDE SUPPLY CO., Inc., 202 South Clark St., CHICAGO, ILL.

PHONE, HARRISON 3840

FROM OUR CHICAGO HEADQUARTERS (Continued from page 79)

the illustration on page 79, was artistically decorated and contained a full line of pianos, player pianos and Brunswick talking machines handled by that company.

R. W. Kincaid, manager of the company, is seen in the right hand side of the booth. In commenting upon the success of the fair, Manager Kincaid, stated that the County Fair held in Canton each year is one of the very biggest events, and as a general rule all business men take advantage of the opportunity to show a line of their wares. "We are advertising the Brunswick line extensively in the newspapers and have had some wonderful results through this medium, but I found that by taking ad-

vantage of a booth at the fair wherein we could show our goods directly to perhaps more people than the newspapers reach, we obtained results that were far beyond our expectations.

"The Brunswick made quite an impression on visitors to our booth because of the fact that thousands of visitors were enabled to have an actual demonstration. Its beauty of design and fine tonal qualities favorably impressed those who heard it, and as a result we made numerous deals while the exhibition was on. Not only were we successful with our Brunswick demonstration, but our piano demonstration—and we handle a good line of pianos, the Gulbransen and Brinkerhoff—also received considerable attention."

Western News Co.'s Expanding Business

The Western News Co., of this city, report excellent developments in their wholesale trade during the past month. Agencies for the company are being placed, and already have been established in the States of Nebraska, New York, Ohio, California, Minnesota, Illinois, South Dakota, Indiana, Connecticut, Alabama, North Dakota, Texas, Oklahoma and Mississippi. The company is offering special advantages at this time to responsible corporations, firms and individuals who desire to tie up to a large progressive and completely organized institution, which is able to produce and actually is producing a phonographic musical instrument of the most splendid type, containing an array of real talking points and built under conditions which absolutely guarantee the finest mechanical and musical results. The Tel-O-Tone, which is the name of the company's phonograph, is being produced now in adequate quantities and in five styles, which retail from \$85 to \$200. The popularity of the line is becoming thoroughly established and all who have seen and heard it are loud in its praises.

When the Western News Co. undertook to go into the phonograph field they also determined to go into their new undertaking so thoroughly well that from the start they should have only the best, without comebacks. They chose to make a high-class article, mechanically and acoustically right, beautiful to listen to and beautiful to look at. The motto of the Tel-O-Tone, "The Soul of Music Dwells Within," is appropriate in every sense. The company's retail warerooms in Chicago are in the famous Republic Building.

Why Advertising Literature Should Be Used

A simple method of advertising that pays was brought to the attention of the Chicago office of The World recently. The story is as follows:

Up on the North Side there is a company that

operates a chain of drug stores, and handles well-known brands of talking machines and records which are extensively advertised. Since taking on the line the company had been doing a little business, but not in sufficient amount to satisfy the manager. After investigation the management came to the conclusion that it was not worth their while to go into the talking machine business as a side line and were on the point of throwing the instruments and records out entirely. Then they made the discovery that the business was on the increase in one of their stores. So they watched this store for a couple of weeks. The business kept on increasing.

Their curiosity was aroused and they made a further investigation. Then they found that one of the boys who wrapped up the packages and made deliveries of goods was making use of the talking machine record circulars that were under the counter.

It seems that both the talking machine company and the record company had sent out to all of the stores a supply of small leaflets, advertising the instrument and records, and these were supposed to be sent out in the monthly mailing list or else kept on the counter. They had been placed, however, under the counter where no one could see them, and in this particular store the errand boy was making use of them to wrap up packages. As a result everyone who had a package delivered from this store received a couple of circulars, and this in turn resulted in calls on the drug store for both records and machines. Of course, the boy was un-

"Orotund" and "Superior" Attachments, Tone Arms and Jewel Points for PERFECT TONE

Recommended by all expert dealers and manufacturers.

The "Best" because they will play all makes of records perfectly, with the least mechanical and surface noise, also most safely.

"Orotund" and "Superior" attachments are scientifically made and perfect in action. The only attachments which will give satisfaction when operated according to instructions.

All up-to-date dealers should handle attachments as there are many favorite records in the world's library made in both hill and dale and lateral cut lines.

Attachments made to fit all standard makes of talking machines.

Write for prices and descriptive circular.

Combination Attachment Co.

20 E. Jackson Boulevard
Chicago, Ill.

Equip Your Phonographs With Perfect Automatic Brakes

Samples
\$1.00 Each
Cash with order

State make
of tone arm used



Also made
with long
brake shoe
for 1 inch
offset

Patented Aug. 28, '17

Simple construction and easily attached.
Made in four styles to fit any make of tone arm.

Write for attractive quantity price

PERFECT AUTOMATIC BRAKE CO.
Room 400, 425 S. Wabash Ave., Chicago

FROM OUR CHICAGO HEADQUARTERS—(Continued from page 80)

conscious of what he was accomplishing by using these circulars in wrapping packages, but when the management ascertained the results orders were given that the same plan be followed at the rest of their stores.

Xmas Posters Ready

The Victor Department of Lyon & Healy is receiving an unprecedented demand from their dealers throughout the country for their new twenty-four sheet service posters. These posters are designed to remind the public that the Christmas season is fast approaching and that the instruments and records mentioned thereon are very suitable and appropriate as Christmas gifts. The posters are printed in such a way that a space is left whereon the dealer's name and address can be printed.

L. C. Wiswell, manager of the Victor department for Lyon & Healy, stated that the requests for December releases of Victor records

are greater than he anticipated and from the way he looks at it there will be an enormous demand for these records. Instead of the regular monthly releases the Victor Co. have selected with care sixty-nine of their best sellers during the past twelve months and the pressing plant will turn out these numbers only.

Fire Laddies Happy

Swift & Co., one of the world's greatest packing companies, have just purchased a Brunswick phonograph from the retail Brunswick store. The instrument together with a fine selection of Pathe records was presented to Fire Engine Co., No. 40. This engine company is stationed in the center of the stockyards.

New Brunswick Agents

It has just been announced that the Wade Graphophone Shop, 14 North Michigan avenue, have taken on the entire line of Brunswick phonographs.

The department store of L. Klein, at Fourteenth and Halstead, one of the biggest department stores outside of the loop district, has also installed a complete line of Brunswick instruments. This deal was brought about through the efforts of Alburn Lippitt, who handles the Chicago territory for the Brunswick Co.

New Vitanola Catalog

It has just been announced by the Vitanola Co. that their new catalog is off the press. This new catalog is highly illustrated and unique in many ways. Its design is entirely different from anything that has ever been offered the dealers before.

Orders Are Steadily Increasing

S. A. Ribolla, manager of the Central States Division of the Otto Heineman Phonograph Supply Co., reports the demand for motors as very active with orders coming in in increasing quantities daily.

Why Is The *Empire* So Popular?

Read This Letter from a Dealer :

EMPIRE TALKING MACHINE CO., CHICAGO, ILL. OCTOBER 21ST, 1918.

Gentlemen:

Kindly duplicate my last order for October records and send them at once, also send me as soon as possible the machines which I ordered from your representative several days ago. I am entirely out of machines—had a big run on them lately and I can only attribute the reason for same is that you now have a good combination, good machines and good records, and we hope to see you continue improvements on the records.

Yours very truly,

Name furnished on request.



Our list of December Records contains 20 numbers. These with the addition of the 15 numbers in the November list and 20 in the October list make a total of over 100 selections, and offer a large variety of the latest musical successes. For list of December Empire records see the Record Bulletin in this issue.



Write for our new catalog and record supplements.

Our agency proposition will also be sent you with these.

Do so today—before some other dealer in your locality beats you to it.



Model A-1

The merchant who sells Empire Machines is selling more than just an ordinary talking-machine—he is selling a satisfaction which becomes an ever-increasing asset to his business. Empire machines make happy homes and prosperous merchants—you can build up a profitable phonograph department by handling Empire machines. You can get the exclusive Empire agency in your city without investing a large amount of money.

Made in 12 models, retailing from \$32.50 to \$500. Each model is constructed with the utmost care and the Empire tone arm will play any make of disc record perfectly.



Model B.

EMPIRE TALKING MACHINE CO.

John H. Steinmetz, President
429 South Wabash Avenue, Chicago, Ill.

FROM OUR CHICAGO HEADQUARTERS—(Continued from page 81)

R. C. WADE CO. INTRODUCES THE "TONOFONE" NEEDLE

Newly Organized Company With Ample Capital and a Strong Business Organization Formed for the Purpose of Manufacturing This New Needle, Which Is the Invention of R. C. Wade

CHICAGO, ILL., November 4.—The R. C. Wade Co., incorporated under the laws of Illinois, makes its formal bow to the talking machine industry this month and announces that it has finally perfected its new needle, to be known as the "Tonofone," and that it is now ready for the market. It is the invention of R. C. Wade. It is worthy of mention that this Tonofone needle is not just an accident, but a product of long, intelligent study and the result of tireless, patient experimenting.

Mr. Wade is an electrician, a clever machinist, a mechanical genius, and withal a great lover of music. As long as four years ago he became interested in the possibilities of the phonograph needle as a medium of sound reproduction. He conceived the idea of a needle "that would be semi-permanent, that would bring out tonal qualities impossible by means of the ordinary steel needle and, at the same time, eliminate those extraneous sounds that so greatly mar phonograph reproduction." The longer he worked the more enthusiastic he became and the perfected Tonofone needle is the result.

This needle is made of a combination of musical metals, specially treated for the purpose. The shank metal is adapted, both musically and mechanically, to receive and carry the needle point proper, which, by process of the Wade construction, is so securely embedded in and fastened to the shank as to make the entire needle practically one piece. The needle point is both ductile and resilient and is burnished smooth and so shaped that it follows the groove of the record, picking up and transmitting, separately and distinctly, the most minute undulations or sound waves—without scraping or scratching on the bottom of the groove. In a word, Mr. Wade contends that the Tonofone needle is mechanically and musically correct.

Mr. Wade's first needles were necessarily crude and, while satisfactory in a measure, being made by hand, the process was slow and the cost prohibitive. This, again, brought Mr. Wade's inventive genius into play and he invented and has developed an automatic machine, on which patents are pending, which turns out the perfected and completed needles at a rate that permits of their being sold in competi-

tion with the other and ordinary needles now on the market.

The company, as will be noted by its advertising, has sufficient confidence in the merits of the needle to give an unqualified "money-back-guarantee." It claims that the needle will play all records, both vertical cut and lateral cut, and says "fix the needle securely in the sound box and without readjustment play record after record." But for best results it advocates playing not more than about fifty records with each needle—which, however, is by no means the needle's limitations.

Meanwhile, the proposition grew beyond Mr. Wade's financial means and, after enlisting the interest of two or three immediate friends, a corporation was formed to provide the necessary additional capital and to carry on the business. Mr. Wade was honored with the presidency, W. W. Gorham was made vice-president and Dorchester Mapes secretary and treasurer. The original incorporation was for \$2,500, which has now been increased to \$50,000, with something over \$30,000 paid in in cash, machinery, general equipment and patents. The issued stock is all in the hands of the original investors and the balance is held in the treasury. The company is offering no stock to the public.

Mr. Gorham, the vice-president, has had a wide practical experience in general merchandising and will devote such of his time as is required to the sales development of the business. Mr. Mapes, secretary and treasurer, has been connected with "big business" in Chicago for a long time. He was first and for many years in the employ of Franklin MacVeagh & Co., wholesale grocers, entering their service as office boy and graduating as head credit man and general office manager. He subsequently served in the latter capacity with the Simmons Co., the world's largest manufacturers of metal beds. Mr. Mapes is now president of the Platinum Mining & Milling Co., which operates the Rambler Mine in Wyoming, this mine having the unique distinction of being the only lode-vein, platinum-producing mine. He was one of the charter members of the Chicago Credit Men's Association and served on their board of directors for several terms. His affairs are now in such shape that he can and will give his first

attention to looking after the executive office of the R. C. Wade Co., Inc.

An extensive publicity and selling campaign has been inaugurated. In general the company purposes following established customs of the phonograph and music trade—it intends to work, first, through the jobber and distributor, but, until the entire field has been thoroughly covered through this medium, it proposes making sales direct to and opening accounts with the retail dealers, as a means of paving the way for the jobber.

In a recent letter to The World's Chicago office the Wade Co. states: "In general we propose conducting our business along lines that are strictly in keeping with good business ethics. We are convinced of the superior merit of our own product and, without disparaging or condemning any other, we shall try and try hard, by all fair means, to convince the public that Tonofone needles are all we claim for them."

The R. C. Wade Co. maintains a general office at 29 South La Salle street, and its factory is located at 538 South Dearborn street, Chicago.

WORLD PHONOGRAPH CO.'S PLANT

New Establishment in Chicago Well Equipped—Chas. Brown Is Superintendent

CHICAGO, ILL., November 10.—The plant of the World Phonograph Co., of this city, is unique in being one of the few plants which to all intents and purposes manufactures the complete machine under one roof. The factory is a large five-story affair with basement, occupying the space of 50 by 125 feet, and laid out in such a way that each machine during manufacture is moved but a few feet at a time instead of being started on one floor and taken to an upper floor and then back



World Co.'s Factory



World Phono. Co.'s Cabinet Shop

to a middle floor before it is assembled. It is a daylight plant equipped with the most modern machinery.

The World Co. is very fortunate in securing



World Phono. Co.'s Cabinet Room

the services of Chas. Brown as factory superintendent. Mr. Brown is a man of long experience, having devoted practically all his indus-

Our Repair Department

WE ARE EQUIPPED TO DO REPAIR WORK OF ALL KINDS

Our experts are men of 20 years' experience in the assembling and repairing of all the mechanical parts of a talking machine and are capable of repairing and adjusting any kind of a motor, sound box or any other part of any make of machine.

All work guaranteed to be satisfactory in every respect.

Efficiency and quick service at all times, with reasonable prices.

Send us your repair jobs and they will receive prompt attention

INCORPORATED UNDER THE LAWS OF ILLINOIS

Consolidated Talking Machine Co.
Manufacturers of

SUCCESSORS TO
Standard Talking Machine Co.
United Talking Machine Co.
Hornum Talking Machine Co.
O'Neill-James Co.
Aretino Co.

High Grade Talking Machines, Disc Records,
Talking Machine Supplies, Etc.

227 W. Lake Street, CHICAGO, ILL.



TRADE MARK
"CONSOLA"

CABLE ADDRESS
"CONSOLA"

FROM OUR CHICAGO HEADQUARTERS—(Continued from page 82)

trial life to the manufacture of talking machines. Under his supervision the plant is rapidly being brought up to the highest efficiency.



World Phono. Co.'s Woodworking Shop

It is centrally located within ten minutes' walk of the loop, and is in the immediate vicinity of Chicago's greatest freight yard center.

The supervision of sales and general conduct

of the business is being looked after by Ernest G. Cook, who is secretary and general manager of the company. Mr. Cook is a man of long selling experience, the result of which is shown by the number of big houses he has landed as distributors for World phonographs in the comparatively short time he has been at the helm.

Since he has been associated with the concern he has sacrificed the quantity and not the quality of his models. For this reason he has confined his output to two models. These can be had in oak or mahogany. Mr. Cook believes that by concentrating the company's energies in this way he can reduce the cost of manufacture to a great extent.

The World Phonograph Co. have recently established two new branches, one at 202 Guardian Building, Denver, Colo. This branch will attend to the wants of the Western part of the country. The other branch was established at 4400 Euclid avenue, Cleveland, O., to take care of business in that section.

Dealers, Jewelers, Phonograph Merchants

GUARANTEE your profits with satisfactory sales and gain the everlasting gratitude of your customers by acquainting them with the

BLOOD PHONOGRAPH PRODUCTS

That it is a BLOOD invention, manufactured under the personal supervision of Mr. Blood, ABSOLUTELY GUARANTEES the trade that it is of the best in the world.

BLOOD'S CONCERT REPRODUCER

created an immense sensation during the War Show in Chicago when it was estimated that over 250,000 people heard it. The result—75% of the first output was sold at retail from our own shop, with less than 2% returns. Every day brings happy expressions from purchasers.

MANY DEALERS in Chicago, some of the largest in the Trade, have proved that the BLOOD REPRODUCER is a "dead-sure" seller—in fact, sells itself upon hearing. When they feel that a talking machine customer is getting away, they slip on a BLOOD REPRODUCER and "clinch" the sale.

AS AN ACCESSORY, you will not alone "drive home" satisfaction on your own past phonograph sales, but also profit on the past sales of your competitor.

The BLOOD REPRODUCER does not "resurrect creation" but simply reproduces NATURAL AS LIFE, which makes it a ready seller at \$6.00 (Mica) and \$7.00 (Mica, Gold) when fitted with the proper flanges for the machine you wish to equip.

WATCH THIS SPACE

for other remarkable BLOOD Phonograph Accessories which will be announced from time to time.

Order Your Blood Reproducer NOW

Usual Discounts. Samples and Shipments sent C. O. D. to all

Phonograph Repair Shop 59 EAST VAN BUREN ST. CHICAGO, ILL.

A. L. SPRING DIES SUDDENLY

Prominent Chicago Piano and Talking Machine Man Passes Away After Attack of Double Pneumonia—Had Long Career in the Trade

CHICAGO, ILL., November 4.—Arthur L. Spring, one of the best-known piano and talking machine men in the country, died at his home in Chicago on Thursday, October 17, of double pneumonia. Mr. Spring was one of the men in the trade whom everybody thought well of. He was said, by those who knew him, to be a friend of a kind that is few and far between. Every place he went, and he traveled the country for a good many years, he was always welcomed with a hearty handshake, as his lovable disposition was unforgettable.

He received his early training as a piano man with the firm of M. Steinert & Sons Co., of Boston, seventeen years ago. After several years with this firm he resigned and became associated with Denton, Cottier & Daniels, of Buffalo, with whom he remained for a period of four years. Upon severing his connections with this firm he went to St. Louis as sales manager of the Aeolian Co.'s branch in that city. He served in this capacity for about six years and then went over to the old Detroit branch of the P. A. Starck Co., where he remained for two years. He then returned to the Aeolian Co., and was connected with their wholesale Vocalion department up until about ten weeks ago, when he assumed both the wholesale and retail managerships of Thos. E. Wilson & Co., talking machine division. Two weeks ago he made a trip to St. Louis in the interests of this company. While in St. Louis he contracted the influenza, which caused him to return to his home.

He is survived by a widow and three children, one of whom is but three months old. His body was shipped to Buffalo, N. Y., where his wife's parents reside.

Be it said to the credit of his last employers, Thos. E. Wilson & Co., that everything possible was done by them to assist Mr. Spring and his family in his last hours.

VOCALION AGENCY FOR PEARSON CO.

Prominent Indianapolis Piano House to Represent the Aeolian Co.'s Vocalion Products, as Well as the Pianola in That City

An important announcement has been made by the Aeolian Co. to the effect that the agency for the Aeolian Co. line of Vocalions and Vocalion records in Indianapolis, together with the Pianola and piano lines, has been placed with the Pearson Piano Co., the old-established and prominent piano house of that city.

The arrangement comes at a most opportune time, inasmuch as the lease on the building occupied by the Aeolian Co. branch in Indianapolis will expire shortly, and in placing the agency with the Pearson Co. the Aeolian Co. will be enabled to close that branch, with the feeling that they will have most adequate representation throughout the territory. The Pearson Piano Co., in addition to its store in Indianapolis, also operates a half dozen successful branches in various parts of the State.

The Pearson Co., fully alive to the prestige that goes with the agency for the Aeolian Co. product, have arranged to devote their excellent facilities to the fullest degree in the exploitation of the Aeolian-Vocalion and Vocalion records. A special department will be devoted to Vocalions, for which there is a big field in Indianapolis and vicinity.

The Pearson Co. have arranged to take over the stock at present on hand at the Aeolian Co. branch, and the work of transferring the stock is already in progress.

The charter of the Quincy Phonograph & Art Co., 411 Hampshire street, Quincy, Ill., has been dissolved. The business was taken over last March by A. F. Odell.



Knights o' the Road

**Your catalogs are your traveling salesmen.
They go into every home in your territory.
Get a supply of the New Catalogs and put
them to work for you.**

**Columbia Graphophone Co.
NEW YORK**

MRS. E. J. BREWSTER IN CHARGE

Appointed Manager of Sonora Phonograph Sales Co.'s Fifth Avenue Salon

Mrs. Edmond J. Brewster, who has been assistant manager of the Sonora Phonograph Sales Co.'s Salons at Fifth avenue and Fifty-third street for the past two years, has been placed in charge of these handsome demonstration rooms.

Chas. S. Ellis, formerly manager of this establishment, has been called to fill the vacancy occasioned by the death of H. W. Bender, formerly manager of the Sonora retail warerooms at 279 Broadway.

Mrs. Brewster has been in charge at the Fifth Avenue Sonora Salons since October 1, and during the month of October her sales totals for the month were double the figures for last October. November has started in equally as well, and, judging from all indications, will show a substantial increase over last year. Mrs. Brewster is ideally qualified for her present post, and has achieved remarkable success in introducing the Sonora phonograph to the high-class Fifth avenue clientele.

WILL BUY TALKING MACHINES

War workers are flocking to Niagara Falls, N. Y., where homes to accommodate them will be built by the Government at a total cost of \$1,650,000. This enterprise spells the extension of the trade of the talking machine dealers of that city.



Ideal for Holiday Sales

In that period of uncertainty as to what to give, show your customers the

CORTINA Phone-Method

Sell them the records, the talking machine and the text books. The Cortina Military French-English course is especially adapted for those going "over there."

Send for full information. Advertising matter and window displays.

The Cortina Academy
12 East 46th Street :: New York

NEW BOOK BY WM. MAXWELL

Vice-President of Thos. A. Edison, Inc., Completes Interesting Work on Salesmanship

William Maxwell, vice-president of Thomas A. Edison, Inc., has completed a new book on salesmanship which is to be published by the



William Maxwell

J. B. Lippincott Co., of Philadelphia, next January. The volume is entitled "The Training of a Salesman."

Mr. Maxwell's previously published volumes and his articles in Collier's Weekly and other magazines during the past two years have earned him a national reputation as a writer on the art of salesmanship. His business career justifies the authoritative tone of his writing, for he has conceived and executed some of the biggest and most successful manufacturers' selling campaigns that have ever been conducted in the United States.

COLUMBIA OFFICIALS ON SICK LIST

The influenza epidemic, and its twin brother, the plain but severe cold, served for a time to deplete seriously the staff of the executive offices of the Columbia Graphophone Co. H. L. Willson, general manager of the company, was confined to his home with a severe cold just when he was in the middle of his work of preparing his report on the priorities question as chairman of the War Service Committee of the Talking Machine Industry. Edward N. Burns, vice-president of the company, was also on the sick list, as was also Edmund F. Sause, export manager, who for a time was very seriously ill.

"There's no time like the present," said the opportunist sagely.

"There's no time but the present," said the other chap more sagely.

DORIAN COMBATS WAR REVENUE BILL

Chief Auditor of Columbia Graphophone Co. Spends Ten Days in Washington and Receives Promises of Favorable Consideration of Arguments Before Bill Is Reported to Senate

Marion Dorian, chief auditor of the Columbia Graphophone Co., returned recently from a ten-day stay in Washington in connection with the new War Revenue bill. Mr. Dorian appeared before the Senate Finance Committee, which now has the bill under consideration, and interviewed the different members of the committee as well as other members of the Senate, in the interests of the talking machine industry. Mr. Dorian stated that his arguments for a more favorable consideration of the talking machine interests were well received, and that the members of the committee promised to give them careful attention. The chairman of the Senate Finance Committee promised that the rate of tax on talking machines was to be taken up for reconsideration before the bill was finally reported to the Senate.

Mr. Dorian stated that there was considerable ambiguity about the action of the bill with respect to the floor tax, and said that suggestions had been made with a view to removing this ambiguity and at the same time reducing the floor tax to the lowest possible minimum.

Mr. Dorian went to Washington on October 19, and did not return to his desk until October 29. He was busy every moment while at the National Capital, and in addition to his work in connection with the War Revenue bill also lent assistance to the War Service Committee of the Talking Machine Industry, with a view to obtaining priority orders from the War Industries Board.

HURT AMERICAN MERCHANTS

German Agents Take Advantage of Trade-Mark Discrepancies

WASHINGTON, D. C., November 9.—German agents seeking to obstruct the expansion of American trade have taken advantage of the wide differences between trade-mark laws of North and South America and thereby have forced American merchants to pay ruinous prices for recognition of their wares in Latin-American countries.

This charge is made in a statement issued today by the International High Commission announcing that progress is being made in ratification by American nations of the convention establishing two trade-mark registration bureaus, one for North and Central America and the West Indian republics and the other for South America.

Instead of waiting until just before Christmas customers of Charles J. Hereth, the East Genesee street, Buffalo, dealer, have already begun to buy New Edisons from him. These are intended as holiday gifts.

ESTABLISH MANY AGENCIES

Burton Collver Doing Good Work for the Cheney in New York and New Jersey Territories Which He Controls—Trade Outlook Good

During the past few weeks Burton Collver, wholesale representative for the Cheney phonograph for New York and northern New Jersey, has established several important agency con-



Burton M. Collver

nections for this high-grade instrument. These agencies have inaugurated extensive campaigns in behalf of the Cheney phonograph, and judging from the enthusiasm of these representatives this line is meeting with signal success in this territory.

Mr. Collver has opened Cheney studios at 4 West Fortieth street, New York, where dealers are invited to call and thoroughly investigate the distinctive qualities of the Cheney. These studios are located in the heart of the Fifth avenue shopping district, and during the past month many out-of-town dealers have taken ad-

vantage of Mr. Collver's invitation to call at the studios.

Burton Collver is well known to the piano and general music trade throughout the country, as he was associated with the piano industry for many years before becoming wholesale representative for the Cheney phonograph. During recent years he occupied important positions with the American Piano Co., M. Welte & Sons and Grinnell Bros., and he has won the esteem and friendship of the dealers throughout the country. He is most enthusiastic regarding the future of the Cheney phonograph, and is now making plans whereby Cheney dealers in this territory will receive efficient service and co-operation during the coming year.

EDISON SALES ADVISORY BOARD

Ten Executives of Thos. A. Edison, Inc., Compose Board Which Will Help Edison Dealers Solve Various Problems in Their Business

Thomas A. Edison, Inc., has just organized a Sales Advisory Board, which will be at the service of Edison dealers throughout the country, and which will give advice and suggestions regarding selling problems, window displays, advertising methods and other matters of importance to retailers. The personnel of the board is as follows:

William Maxwell, consulting director of sales promotion; T. J. Leonard, director of sales forces; L. C. McChesney, advertising (general); A. P. Burns, general and technical questions and promoting sales; V. E. B. Fuller, public demonstrations—recitals, curtain tests; A. J. Palmer, advertising copy and sales letters; Harrison Durant, finances, instalment sales, etc.; Laura Scribner, window displays and interior decorations; E. Trautwein, mechanical problems; C. B. Hayes, musical matters; R. K. Cummings, secretary of the board.

Each member of the board is an expert in some one special line, and the services of a board of this kind will prove very valuable to Edison dealers everywhere.

WHAT TALKER INDUSTRY IS DOING

Excellent Points Made in Interesting Interview With H. L. Willson

There has been prepared and has appeared in various daily papers a most interesting interview with H. L. Willson, chairman of the War Service Committee of the Talking Machine Industry, regarding the work the industry is doing and the sacrifices it is making toward the winning of the war. The interview sets forth the fact that the Government has ordered a 60 per cent. curtailment in the output of talking machines, which will result in lost business amounting to about \$25,000,000 per year. In the interview Mr. Willson emphasizes particularly the great service that talking machines and records are rendering and have been rendering for the period of the war, in providing music for the entertainment and solace of the American fighting man at home cantonments, on ships and on the fighting fronts and in the hospitals in Europe, to say nothing about maintaining the morale of the war workers and others interested at home.

SECURE THE EDISON AGENCY

The Kesselman-O'Driscoll Co., well-known talking machine dealers of Milwaukee, Wis., has secured the agency for the Edison Diamond Disc phonographs, in addition to the Victor line, which they have handled for some time past. The company has a fine shop at 258 West Water street, Milwaukee.

REPORT ACTIVITY IN NEW YORK

The New York headquarters of the Brunswick-Balke-Collender Co. report brisk activity. Chester Abelowitz, now on a New England trip, is sending in very favorable reports from that section of the country. P. L. Deutsch, of the Chicago headquarters, paid a flying visit to the New York office last week.

LONG CABINETS



No. 83

In all finishes. Specially adapted for use with Columbia 50, Model "D." Front posts made to follow lines of posts on Columbia 75, Model "F."

FIRST and FOREMOST

In the cabinet field.

Why? Because we've *specialized* in

**CONSTRUCTION
FINISH and
ADAPTABILITY**

Our supremacy in these essentials warrants your handling *the perfect line.*

That's why you should anticipate your wants **NOW.**



No. 79

In all finishes. Shown with top moulding and shelves. Specially adapted for use with Victrola IX-A.

Prompt deliveries on all orders. Write for Illustrated Catalogue of complete line

**THE GEO. A. LONG CABINET COMPANY
HANOVER, PA.**

A NEW VOLUME THAT STIMULATES MUSIC APPRECIATION

"The Lure of Music," by the Noted Writer, Olin Downes, Treats the Human Side of Music From a New and Most Interesting Angle—Columbia Records Used for Illustration

Once in ever so often a writer on musical subjects, especially a writer of books calculated to inspire musical appreciation, gets a genuine inspiration and leaves the beaten track in order to prepare and offer something that attracts attention, not only for its originality, but for its practicability. One of the writers thus inspired has been Olin Downes, the musical critic for the Boston Post, whose substantial volume, "The Lure of Music," has just been published by Harper & Bros., New York.

"The Lure of Music" depicts the human side of various great composers and offers stories of their compositions that will go a long way to put into the minds of those fortunate enough to read the book a new realization of the fact that music has a human side, the understanding of which, in many cases, means an understanding of music itself. It is the human element that really makes music understandable and interesting.

The most interesting fact is that Mr. Downes pays an unqualified tribute to the value of music as reproduced by mechanical means, and throughout the many chapters of his book refers the reader directly to records by the Columbia Graphophone Co. as illustrating the particular works of the various composers to which he refers in the text. For instance, not only are the human side of the Nocturnes of Chopin described most interestingly, but the reader is referred to Columbia records of the Nocturne in E Flat, and likewise the Nocturne in E Minor, as providing a means for illustrating the meaning of the text in actual music. The plan offers a new line of thought—a new and direct avenue for the development of musical appreciation that should not go unrecognized.

The idea back of "The Lure of Music" is perhaps best described in the author's Foreword, in which he says:

"A friend of mine had a graphophone which he occasionally enjoyed. He used to say that he 'wasn't musical, but he knew what he liked.' His repertoire was small, but pleasing to him, since, thanks to the records, he had become acquainted with some half dozen pieces of fairly good music, and could even whistle scraps of them from memory. He never knew how musical he was until he chanced one day on a paragraph, in a book his daughter was reading, about one of the compositions that he liked. He suddenly realized that this composition told the story of an episode in the life of another man, a human being who lived, struggled, rejoiced, and narrated his experience in the language of tones.

"Having read the story he played the record over again, and discovered that it meant far more to him than it ever had before. He wondered whether there were stories about his other records, and after much searching obtained a little information on the subject that now absorbed his leisure moments. He then invited a number of friends to his home and read them the stories of the records which he played. His friends were delighted and surprised to discover all that the music, thus explained, meant to them. 'When my friend told me this he convinced me that a great need of to-day is a book which shall bring to every home the treasures of the musical world.'

There is no question but that genuine appreciation of music comes only with a complete understanding of what music means. It is all well enough to tell a novice in matters musical that the hearing, or actual playing, of the works of the great composers will bring with it a familiarity, and consequently more or less appreciation, but we really appreciate only that which we actually understand, not that with which we simply become familiar. Under Mr. Downes' plan the reader is given a straightforward, unembellished, and readily understandable idea of what each particular selection means, the circumstances under which it was written, the mood which the composer was in at the time, and the impression he intended to inspire. With this knowledge the reader can take the Columbia record as designated and, knowing just what the music is all about, find a new interest, or perhaps his first interest, in the piece of music that unintroduced would ordinarily not appeal to him in the slightest.

Mr. Downes' new book will also undoubtedly appeal strongly even to those who do not own a talking machine, for it is written in a manner that shows the intimate acquaintance of the au-

thor with his subject, and a knowledge of the facts that enables him to weave an interesting, and at times romantic, web about the composer and his works, which will prove very instructive to the musical novice. It also holds great interest for those who are well up in matters musical, who will find in Mr. Downes' treatment of the various composers and their works new ideas and thoughts that will add still further to their appreciation of the beauties of music generally.

In all, the characteristics and works of thirty-two of the world's leading composers are treated of by Mr. Downes in his book, each chapter being embellished with a crayon portrait of the particular composer drawn by Chase Emerson. The series begins with that most gifted American composer, MacDowell, and includes Rossini, Verdi, Chopin, Liszt, Gounod, Offenbach, Puccini, Leoncavallo, Mascagni, Saint-Saens, Dvorak, Grieg, Tschaikowsky, Balfe, Sullivan, Nevin and others.

From the viewpoint of the talking machine man, of course, the most interesting feature of the book is the direct reference to the Columbia records, for the list, as compiled by Mr. Downes, if made up separately would represent a catalog of the best works of the composers he has selected for mention. In compiling the list, and in other matters connected with its arrangement, the author was afforded the whole-hearted co-operation of the officials of the Columbia Graphophone Co., who extended to him the use of their records and their record libraries, in carrying out his work to a successful completion. In the introduction to the volume Mr. Downes takes particular care to acknowledge his indebtedness to the Columbia Co. for the courtesy extended to him.

Columbia dealers have been quick to appreciate the great value of "The Lure of Music" in stimulating interest in records of the better class, and of the most noted composers, and through co-operation with the Columbia Graphophone Co. they have already placed orders for the books running into thousands of volumes. It is felt that the placing of the book into the hands of the customer means a new disciple for good music, and a new customer for records that are generally classed as standard.

Both the Columbia Co. and Mr. Downes are to be congratulated upon the production of a volume of this caliber, which represents a genuine and most advanced addition to the music library of to-day.

VICTOR FOLDER FOR CHRISTMAS

Handsome Piece of Literature Just Issued for the Use of Victor Dealers

The Victor Talking Machine Co. has just issued a most attractive six-page Christmas folder beautifully printed in colors and bearing the caption: "Some of the Thousand Reasons Why You Should Have a Victrola in Your Home This Christmas." The cover design shows the well-known Victor artists in front of a Christmas tree, and various attractive scenes are depicted in colors on the other pages. A full range of Victrola models are also shown on the folder. The folder is of a size that can be mailed in an ordinary envelope.

BUY VICTOR STOCK IN REDLANDS

Smith Bros., proprietors of the Oriental Art Store, Redlands, Cal., have purchased the Victrola stock of the Adams Music Store, that city, and moved it to their own quarters, where a special department has been fitted up for the display and demonstration of Victrolas and records.

DEATH OF FORREST H. SCHLICK

Forrest H. Schlick, manager of the Schlick Music House, Charles City, Ia., recently succumbed to the "flu." Mr. Schlick was visiting Chicago on business and after a short illness with the disease, which developed into pneumonia, passed away. Mr. Schlick's father will continue with the business.

THE PARR CENTRAL UNIVERSAL TONE-ARM

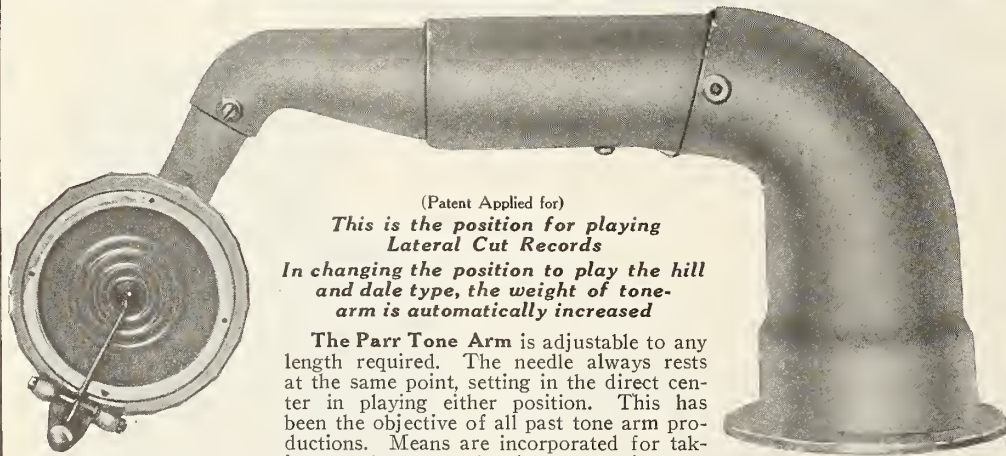

(Patent Applied for)

This is the position for playing Lateral Cut Records

In changing the position to play the hill and dale type, the weight of tone-arm is automatically increased

The Parr Tone Arm is adjustable to any length required. The needle always rests at the same point, setting in the direct center in playing either position. This has been the objective of all past tone arm productions. Means are incorporated for taking up the wear, thereby overcoming any

tendency for loose joints, which is the chief cause of "chattering."

The design of the tone arm permits perfect playing of either type of record without additional attachments. The sound box can be turned, allowing the needle to be changed with ease, and by a reverse movement the box returns to its normal playing position.

Parr Magnetic Reproducer fitted with the Vibratone Patent Diaphragm

The most sensitive of reproducers. The permanent magnetic device, an integral part of the reproducer, acts on the stylus arm. Its possibilities in giving warmth and delicacy in the tonal reproduction of quiet passages make old-style sound boxes seem obsolete. And in fortissimo passages where ordinary reproducers create unpleasant, music destroying blasts, caused by the needle jumping and losing its grip, the Parr Magnetic Reproducer, with its marvelous flexibility, follows every wave and vibration in the record and takes everything the record holds.

The indestructible, non-crystallizing, always resilient **Vibratone Patented Diaphragm**

Possessing all the good points of mica diaphragms, it overcomes all mica's bad features. Guaranteed uniform in quality, free from bubbles, blisters and waves, the Vibratone Patented Diaphragm is non-porous, non-absorbent. It has a definite function and it performs it. It improves tone; in fact it creates new tone possibilities for every reproducer of other types.

PARR MANUFACTURING CORP.
ONE UNION SQUARE - - - NEW YORK

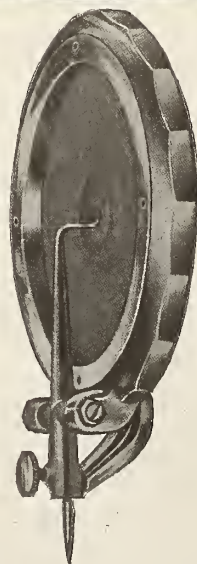

GREAT VOLUME OF CASH BUSINESS IN KANSAS CITY

Talking Machine Dealers Going After Better Class of Trade—Discontinue Approval System—Sending Records to the Army Training Camp—General Trade News

KANSAS CITY, Mo., November 4.—October was an unusual month in the talking machine business from several points of view. In the first place came the Fourth Liberty Loan drive. Following close on the heels of which came the epidemic of Spanish influenza, which has laid a ban on public gatherings for the past four weeks. Yet in spite of these serious drawbacks to business activity many dealers report a very good month's business.

"Our percentage of cash business for the month of October is more than any month since we have been in business," said Mrs. Williams, manager of the Victrola department of the Jones Store Co., "and 400 per cent. more than two years ago. Business is fine though we are suffering acutely from shortage. However, we are still holding to the Victor line, and feel that it is worth the sacrifice to keep our goods up to standard. Our record stock is fairly good, and we are able to keep our customers comparatively well supplied."

A. A. Trostler, of the Schmelzer Arms Co.'s Victrola department, finds the situation little changed from last month. Owing to the shortage of stock, however, the talking machine dealers in Kansas City agreed to adopt the policy of "No records on approval," beginning the first of November. This move will be of material benefit in combating the prevailing scarcity of merchandise and is in addition a health measure to be observed in co-operation with the local health authorities.

W. C. Chestnut, manager of the Brunswick Shop, has been called to New York by the illness of his wife, who was taken with influenza while on a visit.

Lieutenant Leonard Putnam, nephew of Fred H. Putnam, of Putnam-Page Co., Victor wholesalers of Peoria, Ill., is drilling the army mechanics at the Rahe Automobile Training School at Kansas City. Since his arrival the lieutenant has become acquainted with several members of the talking machine trade and has been entertained at the home of B. J. Pierce.

M. M. Blackman, manager of Edison wholesale, has just returned from a brief business trip to Salina, Kan.

J. W. Watson, manager of the Edison retail store, reports a fair business during the month of October. "Business is as good as can be expected," said Mr. Watson, "considering the unfortunate combination of circumstances. We are getting plenty of records, but there is a scarcity of instruments. Collections are very

good and we are getting more cash business than ever."

O. M. Fisk, formerly a wholesale traveler for Edison covering eastern Kansas and northern Missouri, is now on the sales force of the retail store.

Miss Pointer, in charge of the record department of the Edison Shop, has recovered from an extended illness, and has returned to her position.

Burton J. Pierce, manager of the Victrola department of the J. W. Jenkins' Sons Music Co., reports an excellent business with sales and terms keeping up splendidly. Five additional Victrola rooms have been installed on the first floor in connection with the retail record sales department, which has been put in recently. These are only a few of the interior changes and alterations which the house is making with an idea of increasing the efficiency of its service.

For the past year and a half, or since the United States declared war, the J. W. Jenkins' Sons Music Co. has sent hundreds of records and given a great many machines both to army training camps in the United States and to American Expeditionary Forces overseas. For the past two months a movement has been under way to encourage people to send their old records to the automobile training schools for army mechanics in Kansas City, and also to the nearby cantonments. The donations have been handled by B. J. Pierce, of the Victrola department of the Jenkins store, and as a result several thousand records have been sent out.

The Victrola department of the George B. Peck Dry Goods Co. has just completed the best October it has ever had, according to O. D. Standke, manager.

R. E. Wood, formerly in the Victrola department of the Jones Store Co., was in Kansas City on a five-day furlough. Mr. Wood is now stationed at Fort Riley.

The Hall Music Co. has had a very fair business for the month of October and is looking forward to a very brisk Christmas season. Although the stores are urging the public to do its Christmas shopping early little effect has been felt as yet among talking machine dealers.

The Henley-Waite Music Co. is very optimistic over business conditions.

H. N. McMenimen, managing director of the Pathé Frères Phonograph Co., Brooklyn, N. Y., was in Kansas City recently.

The Kansas City branch of the Smith, Barnes

& Strohber Piano Co. is using an attractive window display of Elbertones, the new talking machine recently put out by the company. T. E. Johnston is the manager.

Millard A. Riley, one of the youngest talking machine men in the game and a member of the firm of Jenkins-Riley, of the Pathé Shop, has just completed his training at the School of Military Aeronautics, Austin, Tex., and been stationed at Fort Sill, Okla.

An interesting incident which could be made the basis of a bit of clever advertising was related at the office of Edison wholesale recently. C. S. Hickson, Edison dealer of Richmond, Mo., sold a Laboratory Model to a Mr. Mayer, of that city. To celebrate the purchase Mr. and Mrs. E. Mayer entertained a number of friends at dinner. When the meal was about half finished, to the accompaniment of the Edison, Mr. Mayer's little four-year-old son turned to his mother with a troubled air to ask, "Mamma, when are you going to invite that man in to dinner?"

George F. Standke, manager of the Brunswick Shop at Indianapolis, Ind., stopped in Kansas City on his way to Clinton, Mo., where he spent some time visiting his parents.

L. S. Blythe, formerly wholesale traveler for the Brunswick-Balke-Collender Co., out of Kansas City, is now assisting Mr. Chestnut in the retail Brunswick store.

J. H. Hassel, for the past two years connected with the Victrola departments of the Geo. B. Peck and Jones Store Co., is leaving Kansas City to take a position as manager of the Grafonola department of Eads Bros., Fort Smith, Ark.

Paul Bradford, manager of the Kansas City branch of the Brunswick-Balke-Collender Co., has just returned from a short business trip to Leavenworth, Kan. Mr. Bradford says that business is very good in spite of the shortage of merchandise, and he is anticipating an increasingly brisk trade from now on through the Christmas season.

MURATORE RECORD IS POPULAR

Pathé dealers throughout the country are featuring to excellent advantage the new Pathé patriotic record presenting the "Star Spangled Banner," as sung by Lucien Muratore, the renowned tenor, who is a member of the Chicago Opera Co., and an exclusive Pathé artist. This record has both a timely and patriotic appeal that makes it particularly salable at this time, and the fact that Muratore sings the anthem in English has given Pathé dealers an opportunity to inaugurate effective selling and advertising campaigns in behalf of this record.

RTO
SINGA
and
A
PERFECTION
Music Rolls
LIKE THE PYRAMIDS—BUILT TO LAST
AND
OKEH
RECORDS

Telephone Gram. 3681
FOR
IMMEDIATE DELIVERY
ON
MUSIC ROLLS and
OKEH RECORDS
Heineman and Meisselbach Motors, Tone Arms, Sound Boxes,
Needles, Repair Parts
MILLER & BLOCH
DISTRIBUTORS
110 East 23rd Street, Near 4th Avenue :: NEW YORK

VAN VEEN "BED-SET" BOOTHS



Prepare for the Greatest Talking Machine Trade in History

WRITE FOR A COPY OF OUR NEW CATALOG

It will give you an idea of the attractiveness of Van Veen "Bed-Set" booths, and enable you to make plans for the great "after-war" business that the talking-machine industry will enjoy.

Arthur L. Van Veen & Co. 47 West 34th Street, New York
TELEPHONE - - - GREELEY 4749

LIEUT. J. J. CALLAHAN WOUNDED

Former Traveling Supervisor for Thos. A. Edison, Inc., Now in London Hospital

A letter received by T. A. Edison, Inc., from Lieutenant John J. Callahan, Company "A," 105th Infantry, U. S. A., American Expeditionary Forces, gives a graphic picture of the fight-



Lieutenant John J. Callahan

ing "over there." Lieutenant Callahan is well known in the phonograph industry.

"Sunday last at 5:50 a. m. we started the attack on the Hindenburg line, between Cambria and St. Quentin. The barrage that followed was the most terrific ever laid down on the Western front. I ambled along until about 11 a. m. We were but a short distance from the 'Tunnel' forming part of the Hindenburg system when something (it seemed as though it must have been a locomotive) hit me. I laid in a shell hole with six other wounded men for about three hours, during which time we were peppered with machine gun and artillery fire. The yells and groans of the wounded and dying I shall never forget. I was finally picked up and landed here three days later. I am to be

X-rayed this p. m., after which 'ze operation' will have removed all foreign bodies from my system.

"This hospital is the finest in London—the former home of Lady Warwick; the treatment is too good (for soldiers in my opinion). At times I feel I must be dreaming. To lie between white sheets on a downy couch in a most wonderful home; your meals served in bed—pajamas! bathroom!—all the comforts of a real home! It is a drastic change from the usual routine on the battlefield. From hell to heaven! My namesake, a very good friend, too—Captain John F. Callahan—was captured early Sunday morning. He put up a fight and was killed by Hun bayonets. I am not in writing form as yet, so I must cut this short. I cannot tell the duration of my stay here. I may be removed to another hospital, but I'm sure I'll be O. K. soon again and back to the fray."

COLUMBIA DEALERS MEET IN BOSTON

Regular Monthly Meetings Resumed—Interesting Talk by Olin Downes

BOSTON, MASS., November 6.—The monthly meetings of Columbia dealers were resumed on October 22 at the Columbia headquarters on Federal street, and this was undoubtedly the best and most instructive meeting which has been held. Manager Mann opened the meeting with a heart-to-heart talk with the dealers in which manufacturing conditions were frankly discussed and the expectations as to deliveries of Columbia product frankly outlined. The dealers then had the pleasure of listening to an interesting talk by Olin Downes, musical critic of the Boston Post, and author of the "Lure of Music," published by Harper & Brother, and illustrated with Columbia records. Mr. Downes related the incident leading up to his determination to write a book of this character, in connection with which F. W. Gibson corroborated, and who was also present at the meeting and gave a most interesting talk.

Mrs. Grace Drysdale, New England representative of the educational department of the Columbia Co., then discussed the relations of the dealers to the educational department and the profitable work which could be done by co-ordinated efforts in connection with the sale of Grafonolas and records in the schools and the establishment of children's departments in the dealers' store.

O. F. Benz, of the general record department in New York, presented the November mid-

month records and the dealers had the opportunity of placing their advance orders for the records constituting this excellent list.

LOUIS KAY TENDERS RESIGNATION

Wholesale Representative for S. B. Davega Co. for Sixteen Years to Leave That House December 31—Old-Time Member of Trade

Louis Kay, one of the best-known men in the local talking machine trade, and who for nearly sixteen years has been connected as wholesale representative with the S. B. Davega Co., Victor wholesalers, has announced that he will sever his connection with that organization on December 31. At the present time Mr. Kay states that he has made no definite arrangements for the future.

Mr. Kay is one of the recognized veterans of the industry, and has been connected with the trade for over twenty-two years in all, and has participated in its development from a small beginning to its present importance. He leaves the Davega Co. with the best of feelings existing on both sides, the move being due chiefly to existing conditions, with the resultant scarcity of products. During his service in the trade he has made hosts of friends in all departments, and particularly among the dealers.

PROVIDE NEW CATALOG BINDER

Columbia Co. Offers Special Catalog Holder for Use of Dealers in Demonstration Booths With a View to Conserving Paper

In line with the movement for the conservation of print paper, which can be effected in a considerable measure by reducing the number of bulky catalogs required, the dealers' service department of the Columbia Graphophone Co. have provided a heavy limp leather record catalog binder for the use of their dealers. The binder holds the record catalogs securely, and is attached to the wall of the demonstrating booth with a heavy chain. This is expected to stop the practice of many patrons walking out with the catalogs for which they sometimes have no real use.

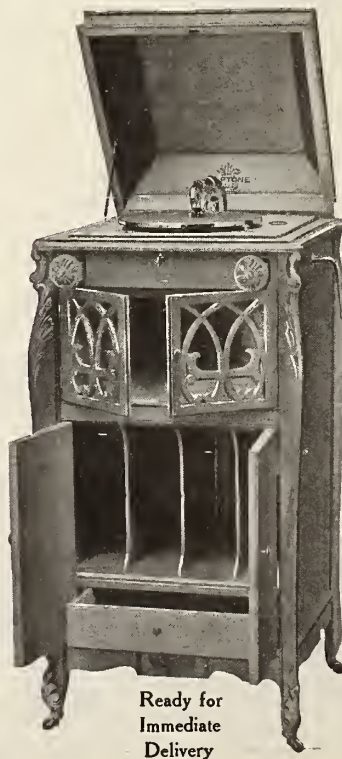

Prices Range from \$80 to \$160 Four Styles

Territory open for Agents

Send for details and dealers' discounts. Helpful booklets furnished to Culptone dealers free.

Culp Phonograph Co.

240 Broadway New York City

Ready for Immediate Delivery

LOOK!

Your windows ought to be working overtime these days—and nights. Go outside—NOW—and take a look. *Couldn't* they be snapped up a bit? It means money, remember.

**Columbia Graphophone Co.
NEW YORK**



IMPORTANT COURT DECISION IN SONORA NAME CASE

Sonora Phonograph Sales Co., Inc., Secures Sweeping Injunction Against General Furniture Co., Chicago, in Action Brought to Protect the Trade-Mark Name "Sonora"

The Sonora Phonograph Sales Co., Inc., through its attorneys, Schechter & Lotsch, of New York, recently brought another suit for infringement of its well-known trade-mark "Sonora," resulting in an injunction against the defendants. This suit was brought against the General Furniture Co., of Chicago, Ill., and others, in the United States District Court, for the Northern District of Illinois. The Sonora Co. claimed that the defendants in marketing and selling talking machines styled either "Saronra" or "Sorona" infringed upon its trade-mark "Sonora," which was a great injury to it, and that by the continued use thereof the defendants were practicing a fraud upon it, and that such acts further calculated to deceive and mislead the public.

The case came up for hearing before United States District Judge K. M. Landis, at Chicago, Ill., on October 28, 1918, and a decree was entered in favor of the Sonora Co., granting it a perpetual injunction against the defendants from using such infringing names, or any other similar names.

Various concerns throughout the country have attempted to profit from the use of names similar to the "Sonora" trade-mark. In talking with the attorneys for the Sonora Co. regarding this matter they say:

"Some time ago the Sonora Co. declared it to be its policy to vigorously prosecute all infringers of its trade-marks. Since then it has brought several suits against such infringers, and, in each instance, has secured perpetual injunctions. The Sonora Co. intends to continue to prosecute all such infringers, and it hopes by this policy to rid the entire trade from these unprincipled business concerns."

To show the recognition given to the Sonora trade-mark by the court, and of the sweeping scope of the injunction, we quote below from the decree as follows:

"The trade-mark or trade name 'Sonora' is an arbitrary word, and was selected and adopted by complainant and its predecessors in interest in or about the year 1907, to designate the goods marketed by the complainant and its predecessors in interest, and to distinguish such merchandise from that manufactured and marketed by others.

"That such trade-mark or trade name 'Sonora' has been continuously used by the complainant and its predecessors in interest, as aforesaid, for upwards of ten years.

"That official recognition has been given to the superior quality and workmanship of complainant's product, in that at the Panama-Pacific Exposition in 1915 the Jury of Awards granted to complainant's product the highest prize for tone quality, thereby recognizing and endorsing the 'Sonora' phonograph or talking machine as superior in tone quality to all other makes of phonographs or talking machines on the market.

"That the high standard of quality and excellence of complainant's phonographs or talking machines has become well and universally recognized by the public generally.

"That for the purpose of suitably and efficiently marketing said product and thereby introducing the same into general public use, the complainant and its predecessors in interest have expended vast sums of money, in excess of many hundreds of thousands of dollars, in conducting national and country-wide advertising campaigns and adver-

tising its product in the leading daily newspapers, in trade papers, and in periodicals and magazines, and in billboards and the like, throughout the United States, including the City of Chicago, County of Cook, and State of Illinois.

"That by reason of the high quality and superior workmanship of complainant's product, sold and distributed under said trade name or trade-mark 'Sonora,' and due to the extensive advertising by complainant and its predecessors in interest, as aforesaid, there has resulted an increasingly large public demand for complainant's product, and the trade name 'Sonora' thus permanently kept before the public as designating not only the complainant, but also its product has become well and generally known in the City of Chicago, County of Cook, and State of Illinois, and throughout the United States, and such trade name is a property right and a valuable asset of this complainant

"That the value of the complainant's trade name or trade-mark and of its good will greatly exceeds the sum of one million dollars (\$1,000,000).

"That the defendants beginning with, to wit, the month of December, 1917, and now are, manufacturing, selling, advertising, marketing or exploiting in the City of Chicago, County of Cook, and State of Illinois, and elsewhere, phonographs or talking machines styled, exploited, marketed and sold as 'Saronra' or 'Sorona,' and so exploited, manufactured and sold by said defendants, are of an inferior quality and workmanship, and are greatly inferior to the quality of said complainant corporation.

"That the adoption and use by said defendants of the words 'Saronra' and 'Sorona,' or either of them, is a fraud and injury to the complainant, and is an infringement of the complainant's trade name and trade-mark 'Sonora,' and of complainant's exclusive right therein, and the use by said defendants of said names 'Saronra' or 'Sorona' is a continuing and irreparable injury to said complainant, and the use of said names, 'Saronra' or 'Sorona,' if continued,

would be likely to deceive and mislead the purchasing public. "IT IS THEREFORE ORDERED, ADJUDGED AND DECREED that the defendants, their officers, agents, representatives, successors and assigns, and each of them, are perpetually enjoined from transacting any business under the names of 'Sonora' and 'Saronra,' or using the said names, or either of them, or any simulation of either of said names, as a trade name or trade-mark for any sound reproducing or talking machine, and from using in any advertisement, announcement, placard, correspondence, or in any other way, the words 'Sonora' and 'Saronra,' or either of them, or any other words, so nearly resembling either the words 'Sonora,' or 'Saronra' or 'Saronra' as may be calculated to deceive or mislead the trade or the purchasing public."

MANUFACTURERS HONOR WILLSON

General Manager of the Columbia Co. Elected Vice-President of American Manufacturers' Export Association Last Week

H. L. Willson, general manager of the Columbia Graphophone Co., was elected one of the vice-presidents of the American Manufacturers' Export Association, at its ninth annual convention held at the Waldorf-Astoria in this city last week. The convention was devoted to the discussion of the post-war trade with special reference to the export field, and one of the valuable suggestions made was that the American soldiers now in France will be well qualified to become export salesmen and agents after the war. A resolution was passed requesting the Secretary of War to utilize and enlist the services of the various agencies connected with our military operations at home and abroad in assisting the need for foreign trade service.



809

Mahogany, Golden Oak, Fumed Oak, Weathered Oak, Nickel-plated trimmings. Lock and key. Height, 33 inches. Top, 22 3/4 x 19 1/4 inches. Holds 192 twelve-inch records. Matches new Victrola IX. Highest type of cabinet, both in construction and finish. Average weight crated, 80 lbs.

IMMEDIATE DELIVERIES

Specials

FOR

Victrola IX

WE have in stock other cabinets to fit all styles of machines and will be glad to send our catalog for the asking.

Now Ready

Mahogany cabinets to match the new Victrola VI.

Schloss Bros.

635-37 West 55th St.

NEW YORK

Phone
Columbus 7947



702

Mahogany, Golden Oak, Fumed Oak, Weathered Oak, Nickel-plated trimmings. Lock and key. Rubber-tired wheels. Height, 30 inches. Top, 17 x 20 1/4. Matches new Victrola IX. Top has countersunk holes to accommodate rubber bumpers on machine. Moulding on top securely fits base of machine. Average weight, crated, 75 lbs.

IMPORTANT NOTICE

TO THE AMERICAN TRADE

The Sterno Manufacturing Company
19 CITY ROAD LONDON, E. C. ENGLAND

Manufacturers of the world known COMPACTOPHONE—the most complete portable gramophone extant—beg to announce the conclusion of arrangements for the EXCLUSIVE SELLING RIGHTS IN THE UNITED STATES OF THE

High Grade Motors Manufactured By **Mermod Freres** St. Croix Switzerland

WONDERFUL MECHANISM

These motors represent the acme of workmanship and quality. Each part is made to the finest gauge limits and assembled to run with the precision of a watch—silent and true. Messrs. Mermod Freres is an old established Swiss manufacturer. Back of their motors are years of hard practical experience. The experimental stage was left behind a decade or more ago. Reliability and quality is therefore assured.

DIFFERENT MODELS

Mermod Freres motors comprise several types—single and double spring worm and pinion-gear drive, the very latest and scientific method of construction.

CONSULT US

Before placing your orders elsewhere consult us as to prices and terms of trading. We are out for quick shipments and prompt delivery direct from the factory to the buyer.

SPECIAL TERMS TO JOBBERS

Within the near future it is proposed to establish
A CENTRAL DISTRIBUTING DEPOT IN NEW YORK
Meanwhile trade enquiries should be directed to

THE STERNO MANUFACTURING CO.
19 CITY ROAD LONDON, E. C. ENGLAND

Responsibilities of Dealer and Manufacturer Anent Talking Machine Up-Keep :: By J. A. Steinmetz

In a recent article written for a furniture paper, J. A. Steinmetz, of the Empire Talking Machine Co., Chicago, presented some sound information regarding the responsibilities of the dealer and the manufacturer in the matter of talking machine upkeep—information that if properly absorbed by dealers should serve to cut down the number of complaints to, and demands made upon, talking machine manufacturers in the matter of replacement of broken springs and other parts. In this article Mr. Steinmetz says in part: "What does the furniture dealer do when a customer comes to him with a repair complaint? The machine is out of order and does not play perfectly—a spring breaks or some piece of the diaphragm has become damaged. Years ago, when furniture dealers handled pianos more extensively than they do now, they would know exactly what to do under the circumstances. They would tell the customer that the damaged part would be sent on to the factory and returned in good condition within a short time, and, last but not least, the charge would be reasonable. If the piano needed tuning, a man would be sent out to do the work and a reasonable charge made for the job. The customer did not complain. He wanted the work done and was willing to pay for it when he was informed that he could not get it for nothing.

"But, here is a horse of an entirely different color. Let the talking machine dealer receive a complaint from a customer that a spring has broken and right away he writes a letter to the manufacturer and tells him that he expects a new spring for nothing as the machine was guaranteed. He gives the customer the impression that he'll get it in a 'jiffy' and no 'ifs or ands' about it. Most dealers do not know that the springs are not guaranteed by the makers, and the talking machine manufacturers naturally can not guarantee what is not guaranteed to them.

"The machines leave the factories only after the most thorough tests. They reach the dealer in perfect order, ready for demonstration to customers, and the dealer should see to it that a representative of the store goes with it to test it in the home within a few days after its delivery. If the machine is found in good working order after delivery to a customer, then why, in the name of fair play, should the dealer expect the manufacturer to furnish all repairs free for an indefinite period? Of course, this question does not apply to such mishaps as sometimes occur wherein the manufacturer can be held responsible because of flawed construction which has escaped the notice of the inspector, but to those repairs that are bound to come sooner or later to any user of a talking machine.

"There are adjustments needed from time to time in a talking machine, just the same as a piano needs tuning and if a machine needs adjustment the store should be in touch with a reliable mechanic who understands his business so that he could be sent out to the customer's home to do the necessary work—and be sure and don't forget that a man's time is worth something and bill the customer accordingly. One dealer has a habit of crating up every machine and sending it back to the factory every time it needs attention and he also has the habit of refusing to put his O. K. to the invoices for work done on these machines by the manufacturer, claiming that since he has accepted the agency for that particular make of machine they, the manufacturers, should see to it that the machines are kept in order, and without any expense to him. The outcome was that the agency was taken away and placed with another dealer in that city, which, by the way, was of sufficient size to have made it an easy

matter to have found several good experts on that class of work. As for minor repairs, a supply of parts should be kept on hand and reasonable charges made.

"A good plan, one now in force in some cities, is to call upon the other dealers who handle talking machines and combine with them in maintaining a phonograph repair department, this department being run for the benefit of all dealers and the expense divided pro-rata among those benefitted by it. The department would charge each dealer for work done, and

he, in turn, would charge the customer. A department of this sort should be self-sustaining and, if properly managed, could be made a profit producer.

The wide-awake dealer who wants to have a successful talking machine department must install a repair department or see to it that he can call upon some responsible party to do the work for him. One large dealer has his collectors make the minor adjustments, when needed, on their monthly rounds, and also make notes of other necessary repairs needed.

HOFFAY PRODUCTS IN THE WEST

The George A. Lowe Co., Ogden, Utah, who for some time have been the exclusive distributors of the Hoffay Talking Machine Co.'s, Inc., products in the State of Utah, have been given the rights by the Hoffay firm as distributors for Utah, eastern Nevada, western Wyoming and southern and eastern Idaho. Since taking over the jobbing rights in the above territories the George A. Lowe firm has met with much success, and in recent letters to the Hoffay Talking Machine Co. have sent a long list of dealers in that

section of the country who are featuring the Hoffay products.

SCHLOSS BROS. OFFER NEW CABINET

Schloss Bros., the well-known New York cabinet manufacturers, have now placed on the market a new cabinet to match the new mahogany Victrola VI. The firm announces that they are now in a position to make deliveries on this new style, and catalogs and prices of this and their other cabinets will be sent upon application.



THE IMPROVED No. 10



RECORD BRUSH

Patented Sept. 26 and Oct. 2, 1906
Sept. 10, 1907, and Nov. 27, 1917
Others Pending



NICKEL PLATED 35 CENTS

For Victor Victrolas

GOLD PLATED 75 CENTS

A RECORD CLEANER

That Automatically Removes Every Particle of Dust and Grit from the Record Grooves

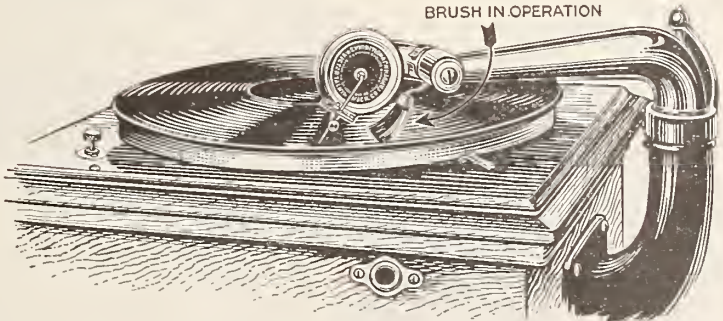

BRUSH IN OPERATION

An article that every owner of a Victrola needs and

A money maker for the dealer

Order from your Distributor

Circular and Price List mailed free on Request

By



Blackman
TALKING MACHINE CO.
97 CHAMBERS ST. NEAR CHURCH ST. NEW YORK



Victor Distributors

HONOR ROLL CONTAINS 38 NAMES

New York and Chicago Talking Machine Co.
Pays Honor to Former Employes Now in the
Service of Uncle Sam—Letter From Front

On another page of this issue of The World there is reproduced an honor roll listing the names of the former employes of the New York Talking Machine Co. and the Chicago Talking Machine Co., Victor wholesalers, who are now members of Uncle Sam's fighting forces. This honor roll lists thirty-eight names, and when it is considered that the total number of male employes of these two companies prior to the United States entering the war was eighty, this record is indeed a remarkable one. Practically 50 per cent. of the employes of this company volunteered to fight for the United States and humanity, and this percentage is undoubtedly one of the highest of any industrial concern in the country.

Some time ago mention was made of the fact that W. G. Porter, formerly a member of the New York Talking Machine Co.'s staff and now fighting in France, was awarded the D. S. C. for signal bravery under fire. Since that time word has been received that five of the former members of the New York and Chicago Talking Machine Co.'s forces have been injured in battle, and a letter recently received from M. C. Stegner, formerly of the New York staff, gives the details incidental to his injury. This letter, which is addressed to Roy J. Keith, manager of the company, reads as follows:

"Since my last letter to you much has happened. I went into action on the American offensive in the St. Mihiel salient September 12. I lasted until the morning of September 15, and then they got me. We were advancing very steadily through thick woods, which were terribly hilly, and while going through the woods the Germans shelled us heavily with high explosive shells. Very unluckily for me I got in the way of one of them and as a result have

been in the hospital ever since. I was wounded pretty badly; in fact, bad enough to require two operations to get me straightened out. I was lying on the ground at the time I was hit, and the shell burst behind me about ten feet away. A piece of it struck me almost in the center of the right shoulder blade in the back, and it came out under my right arm, exactly in the center of my arm pit. For a while I thought my arm was shot off, but gradually it came back to life, and I felt a lot better.

"On the way back to the first aid station I picked up another fellow who had his jaw shot away on the right side, and as he was nearly all in I helped him along. We were getting along fine when all of a sudden we were seen by a

Boche machine gun, and they opened up on us full speed. Believe me, we hit the dirt in a hurry and crawled into some bushes. We finally got out of the woods and started across a large open field when a German sniper gently shot at us no less than fifteen times before we got completely out of his range. The only reason he didn't hit us was because we were pretty far from him.

"Since then I have been operated on twice, and now I am O. K. I am not sure about getting back to my company, for my right shoulder will never be exactly well enough, as a lot of muscles and cords are all mixed up, but otherwise I feel fine. Kindly remember me to all the boys and girls. (Signed) M. C. Stegner."

JOSEPH F. COLLINS' NEW POST

General Sales Manager of the Pathé Frères
Phonograph Co. Acquires Interest in Safe-
guard Checkwriter Co.

Joseph F. Collins, formerly general sales manager of the Pathé Frères Phonograph Co., Brooklyn, N. Y., and one of the best-known members of the talking machine industry, resigned from this position the first of the month. Mr. Collins has acquired an interest in the Safeguard Checkwriter Co., Lansdale, Pa., and will be general manager of this company in charge of distribution and merchandising. The company has New York offices at 5 Beekman street, and Mr. Collins will spend his time both at the factory and in New York.

J. F. Collins can be termed one of the real "veterans" of the talking machine industry, for he has been associated with the trade for the past twenty-one years. He is personally known to the majority of the dealers, jobbers and manufacturers from coast to coast, and he has won the esteem and friendship of the entire industry. During his twenty-one years he has occupied several important posts, and his indefatigable efforts during the past few years have contributed materially to the tremendous suc-

cess and growth of the Pathé Frères Phonograph Co. In his new field he will have unlim-



Joseph F. Collins

ited opportunities to exercise his executive and sales acumen, for the future possibilities in his new work are tremendous.

The Arrow Points in Both Directions If You Have the Eject-O-File in Stock

Profits
on
Machine
Sale



Profits
on
Eject-O-File
Sale

The many advantages of this highly efficient record filing device, that produces the record wanted at the touch of a finger, are so pronounced that sales are easily made

Eject-O-Files are built to fit: COLUMBIA Style 75. VOCALION Styles F, G, H, I, J, K,
and ED!SON Styles C150 and 100

Retails at \$10. In beautiful oak or mahogany finish. Polished, wax or dull finish. Write for descriptive circular and details so that you may see the opportunities this line holds for you.

EJECT-O-FILE SALES CO.

216 W. SARATOGA STREET



BALTIMORE, MD.

BIG RECORD "DRIVE" A SUCCESS

Public Meetings Held Every Day at Wanamaker's in New York—Other Cities in Line—Calculated to Gather One Million Records

The great "drive" for the collection of talking machine records for distribution among the soldiers in camps and cantonments in this country and overseas and on many ships of the navy, under the supervision of the Phonograph Record Recruiting Corps, 21 East Fortieth street, New York, which was conducted for over a week ending November 4, is conceded to have been a great success not only in New York but throughout the country.

A feature of the drive was a public meeting with music at the Wanamaker auditorium every afternoon, at which prominent speakers, including Major-General Bell, and such well-known musical figures as Maud Powell, David Bispham, Francis Rogers and a number of others were heard. The public was invited to bring a record as an admission to these concerts, and cash was also received.

In the prosecution of this campaign local committees were fully organized in over three hundred towns and cities throughout the country, and it is expected that as a result of this great "drive" a million records have been collected. A systematic survey of the camps of the country has been made and records will be distributed through the authorized official and semi-official welfare organizations. The various committees engaged in this work are certainly entitled to commendation and sincerest praise for their untiring efforts in making this movement a success.

A feature of the campaign was the meetings on the steps of the New York Public Library, where from what seemed to be a huge talking machine the voices of well-known singers were heard. The singers in person stepped into this large case and accompanied by a piano their voices rang out over the crowd; in the meantime the musical program was interspersed with appeals to the people to contribute either records, machines or money to buy them for the boys at the front.

On the evening of October 29 there was a concert at Carnegie Hall in behalf of this good cause, when eminent artists headed by Schumann-Heink, Frieda Hempel, Maud Powell, Lazaro, Rogers, Middleton and others were heard, the proceeds of which are to go to the work of collecting the million records needed for our fighting forces. A feature of the entertainment was the reappearance of the young French pianist, Lacroix. Among those present at the concert was Major-General Bell, who addressed the audience on the need of music for the men in service.

Mr. Smith will continue the business of Keenan & Smith, Auburn, Neb., recently dissolved.



Style Five
Georgian Period

The
CHENEY
PHONOGRAPH

"Plays all records better"

Immediate Deliveries
from New York warehouse

We have a splendid proposition for aggressive and successful dealers. Write for catalogs and agency details.

BURTON COLLVER
Wholesale Representative
(Cheney Talking Machine Co.)

4 West 40th Street, New York Telephone, Murray Hill 6576

THE NEWEST DOEHLER BUILDING

Great Plant of the Doehler Die Casting Co. in Brooklyn Now Covers Nearly Entire Block

Work is rapidly nearing completion on the newest building of the group which forms the Doehler Die Casting Co.'s immense plant in Brooklyn, N. Y. With the addition of this new-



The Great Doehler Plant

est building, which is located on the corner of Court and Huntington streets, the Doehler Die Casting Co. will occupy almost the entire city block.

The growth of this plant during the last few years has been remarkable. The original building of the group, situated in the middle of the block on Ninth street, still remains, but the newer buildings made necessary by their constantly increasing business overtowers the old home. The new corner building will be the largest in the group and outstrips the others not only in area but in height as well.

The Doehler Die Casting Co. has long made a specialty of casting talking machine parts and have as their customers in this department a large number of the leading talking machine manufacturing houses in the country.

The Doehler Die Casting Co. have also plants located in Newark, N. J., and Toledo, O., and is said to be the largest manufacturer of die castings in the country.

HEINEMAN MOTION PICTURE SLIDE

Dealers Afforded Convenient Means for Featuring OkeH Records

The advertising department of the Otto Heineman Phonograph Supply Co., New York,



Heineman Motion Picture Slide

has just prepared for the use of its dealers an attractive series of motion picture slides featuring "OkeH" records. These slides are being used to excellent advantage by the dealers handling these records, who have made arrangements whereby the slides will be shown regularly in their local theatres.

One of the slides in this series is shown herewith, although the black and white illustration hardly does justice to the attractive coloring of the slide. Publicity is being used in practically every form in behalf of "OkeH" records, and has contributed to their success.



TEN INCH

Operaphone

PLAY WITH STEEL NEEDLE
ON ALL UNIVERSAL TONE ARM MACHINES

Records

COMPLETE CATALOGUE SENT ON REQUEST

OPERAPHONE CO., INC., LONG ISLAND CITY, N. Y.



ARTISTIC GRAFONOLA PARLORS

Hardman, Peck & Co.'s Attractive Establishment in Brooklyn Has a Series of Demonstrating Booths Which Have Won Approval

One of the many record demonstrating rooms in the Grafonola parlors of Hardman, Peck & Co.'s attractive establishment in Brooklyn is here illustrated, fully equipped for the expedient sale of records with every needed appointment. The outstanding feature of this arrangement is its extreme neatness, effected by the careful framing of monthly bulletins of records, the absence of a disorderly catalog table, and the neatly framed photogravure of a celebrated Columbia artist. The photogravure is a standing invitation to hear this artist's Columbia recordings, and this form of suggestion is a highly dignified one, and a potent sales factor.

The use of metal fixtures, in which to display the regular monthly bulletins, is an econ-

omy of space as well as a practical medium for showing the latest records. Contained in the large or No. 2 fixture are twelve of the regular monthly hangers, one on each side of each of the six wings. The smaller one, over the Grafonola, or the No. 1 fixture accommodates eight of the midmonth lists, or hangers containing seasonable or unusual record offerings.

TO FEATURE THE AMBEROLA

Edison Shop Enlarges Amberola Department, and Will Advertise Same Extensively

The Edison Shop on Fifth avenue at Forty-first street, New York, has just enlarged its

partment. We intend to advertise this department in the New York newspapers. We are going to stir up a lot of sleepy record buyers, and start them coming regularly to the Edison Shop for their Blue Amberol and Royal Purple records. We believe that there is a tremendous amount of Amberola business here in New York for the dealer who goes after it, and this applies to the whole country. It is our ambition to have every Edison dealer become an Amberola specialist. We know just what the Amberola can and will do for the dealer who throws himself solidly behind this proposition. The Amberola department is a gold mine, and the amount of gold a dealer gets out of it depends entirely on how hard he works and how deep he digs. Our advice to all dealers is: 'Work your Amberola gold mine to the limit.'

R. W. Anderson, manager of the Victor department of John Boesch Co., Burlington, Ia., is the proud and happy father of a brand new baby boy.



Hardman, Peck & Co.'s Grafonola Parlor in Brooklyn

omy of space as well as a practical medium for showing the latest records. Contained in the large or No. 2 fixture are twelve of the regular monthly hangers, one on each side of each of the six wings. The smaller one, over the Grafonola, or the No. 1 fixture accommodates eight of the midmonth lists, or hangers containing seasonable or unusual record offerings.

The fixture to the extreme right of the photograph is a No. 4 catalog rack, which does away

with a table and puts before the customer a complete assortment of Columbia record brochures. This rack will show nine different catalogs, three on each shelf, behind which may be filed an extra supply of from eight to ten, according to the thickness of the book. The lower tier of the rack is somewhat wider than the two above, and will accommodate the large general record catalog. The dealer service department of the Columbia Graphophone Co. furnishes a wide variety of metal display fixtures for booths and window display purposes, and advertising material need not be carelessly exhibited about the store.

Amberola line. In a recent interview E. C. Boykin, its manager, outlined the plans for this increase of Amberola business. "The Amberola business in New York City has been neglected too much," said Mr. Boykin, "and the Edison Shop is preparing to go after it hard. We have just established a special Amberola department right here in the heart of little old New York. There isn't a more attractive sales-room in New York City than our Amberola de-

STATEMENT OF THE OWNERSHIP, MANAGEMENT, CIRCULATION, ETC. REQUIRED BY THE ACT OF CONGRESS OF AUGUST 24, 1912, Of The Talking Machine World, published monthly at New York, N. Y., for November 15, 1918.

STATE OF NEW YORK, COUNTY OF NEW YORK, ss. Before me, a Notary Public, in and for the State and county aforesaid, personally appeared J. B. Spillane, who, having been duly sworn according to law, deposes and says that he is the Editor of The Talking Machine World, and that the following is, to the best of his knowledge and belief, a true statement of the ownership, management (and if a daily paper, the circulation), etc., of the aforesaid publication for the date shown in the above caption, required by the Act of August 24, 1912, embodied in section 443, Postal Laws and Regulations, printed on the reverse of this form, to wit:

1. That the names and addresses of the publisher, editor, managing editor, and business managers are: Publisher—Edward Lyman Bill, Inc., 373 Fourth avenue, New York City. Editor—J. B. Spillane, 373 Fourth avenue, New York City. Managing Editor—J. B. Spillane, 373 Fourth avenue, New York City. Associate Editor—J. Raymond Bill, 373 Fourth avenue, New York City. Business Manager—None.

2. That the owners are: (Give names and addresses of individual owners, or, if a corporation, give its name and the names and addresses of stockholders owning or holding 1 per cent. or more of the total amount of stock): Edward Lyman Bill, Inc., 373 Fourth avenue, New York City; Caroline L. Bill, New Rochelle, N. Y.; J. B. Spillane, 373 Fourth avenue, New York City; J. Raymond Bill, 373 Fourth avenue, New York City; Estate of August J. Timpe, 164 Fifteenth street, West New York, N. J.; B. B. Wilson, 373 Fourth avenue, New York City; Carleton Chace, 373 Fourth avenue, New York City; L. M. Robinson, 373 Fourth avenue, New York City; E. P. Van Harlingen, 209 South State street, Chicago, Ill.

3. That the known bondholders, mortgagees, and other security holders owning or holding 1 per cent. or more of total amount of bonds, mortgages, or other securities are: (If there are none, so state.) None.

4. That the two paragraphs next above, giving the names of the owners, stockholders, and security holders, if any, contain not only the list of stockholders and security holders as they appear upon the books of the company but also, in cases where the stockholder or security holder appears upon the books of the company as trustee or in any other fiduciary relation, the name of the person or corporation for whom such trustee is acting, is given; also that the said two paragraphs contain statements embracing affiant's full knowledge and belief as to the circumstances and conditions under which stockholders and security holders who do not appear upon the books of the company as trustees, hold stock and securities in a capacity other than that of a bona fide owner; and this affiant has no reason to believe that any other person, association, or corporation has any interest direct or indirect in the said stock, bonds, or other securities than as so stated by him.

5. That the average number of copies of each issue of this publication sold or distributed, through the mails or otherwise, to paid subscribers during the six months preceding the date shown above is..... (This information is required from daily publications only.)

J. B. SPILLANE, Editor. Sworn to and subscribed before me this 30th day of September, 1918. (Seal) EUGENE R. FALCK, Notary Public, No. 6, New York City.

(My commission expires March 30, 1920.)

A \$15.00 Phonograph That Is Guaranteed

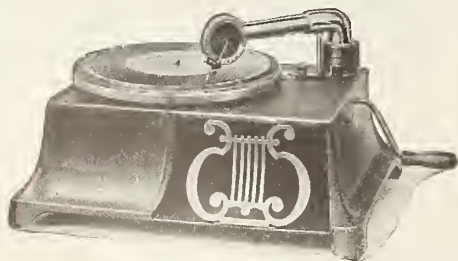

VANOPHONE MODEL C

Manufactured by a company of country-wide prestige.

Vanophone dealers are making substantial profits from the sale of the Vanophone Model "C" retailing at \$15.00.

The Model C Will Play All Records Made

The Vanophone is no experiment, but an established success. It is guaranteed throughout, and every part has been thoroughly tested by our factory experts.

IMMEDIATE DELIVERIES ASSURED

THE GARFORD MFG. COMPANY, Dept. B, ELYRIA, OHIO

DOEHLER DIE-CASTINGS

Have been an important factor in the development of the most successful talking machine attachments on the market.

This, together with the fact that the greatest number of instruments produced are equipped with tone arm and sound box of Doehler manufacture, is a tribute to the uniformly high quality of our product and the all around dependability of our service.

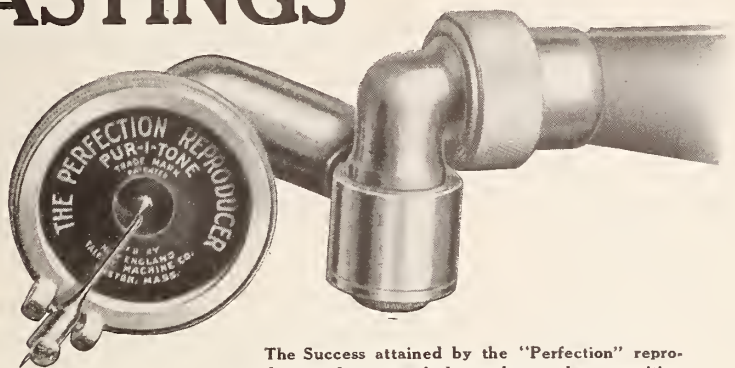

The Success attained by the "Perfection" reproducer and tone arm is due to the popular recognition of a device of more than usual merit.

DOEHLER DIE-CASTING CO.

WESTERN PLANT TOLEDO, OHIO. MAIN OFFICE AND EASTERN PLANT BROOKLYN, N. Y. NEW JERSEY PLANT NEWARK, N. J.

REPAIRS

TALKING MACHINE TROUBLES AND HOW TO REMEDY THEM

Conducted by Andrew H. Dodin

[This department of The Talking Machine World is designed for the service of all classes of our readers, including those who make, and those who sell, talking machines. Andrew H. Dodin, who conducts this department, has a wide and enviable reputation as a repairer of talking machines and conducts an exclusive talking machine repair shop at 176 Sixth avenue, New York. Tell him your troubles through The World and he will help you if possible. The service is free.—Editor.]

SOUND BOXES

The Victor Exhibition Sound Box

In order that the dealer may become familiar with the different ways in which sound boxes are constructed I am going to take up in detail the assembling of various makes of sound boxes.

Possibly the best-known boxes to the average dealer are the exhibition sound box of the Victor Co. and the No. 6 sound box of the Columbia Co., and to these two I will confine my first article.

Assuming that the dealer is familiar with all the parts composing an exhibition sound box we will go ahead and assemble one in the following way:

First, place an insulator in the cap ring in such a position as to bring the joint directly under the bar of the needle arm. Put a little shellac around the top of the insulator to hold diaphragm in place—be sure that it is held firmly to the insulator by the shellac and be positive that its edge does not touch the cap ring at any spot.

If diaphragm touches cap ring at any place it will almost always cause a blast or false note, so always be sure to shellac it in its proper position so that it does not touch. This is of great importance if you want the best results.

Now place the second insulator into position, the joint being placed on the opposite side of the cap ring to that of the other insulator. Put on metal back and set in the three screws which hold it in place—as tight as possible.

Take the needle arm and put on the springs at right angles to the arm, setting up the screws good and tight. Put the spring screws in springs and screw lock nuts into position. Now the needle arm is ready to set in place on the cap ring.

Put the two slots on the needle bar over the

fulcrum points, screw in the two needle arm spring screws as evenly as possible, so that needle arm rests firmly on fulcrum points without any side motion.

The toe of the needle arm should clear the surface of the diaphragm about 1/1000 of an inch. The lock nuts on tension screws are now screwed up tight against the cap ring to prevent the position of needle arm being changed.

Hold box in left hand with forefinger pressing needle arm against diaphragm. Take piercing tool and pierce hole through diaphragm, letting point of piercer pass through top hole in toe of needle arm. Then take 00x112 top and run through diaphragm and needle arm toe holes to clear them of any obstructions.

Place diaphragm screw with its paper washer in position—which will pull needle arm toe down tight to surface of diaphragm.

Heating waxing wire, take a little wax and put a drop over the head of the diaphragm screw and also over toe of needle arm.

Put on rubber back with its two screws, place needle set screw in needle arm and the sound box is complete and ready to be tested.

Columbia No. 6 Sound Box

The Columbia No. 6 sound box differs from the exhibition sound box in that it does not use any means of tensioning the needle bar. The needle bar is swung on two pivot points and the elasticity of the mica diaphragm is depended upon to assist the push and pull of the needle.

In assembling this box we place first the large paper washer in the bottom of the head, next, one of the heavy rubber gaskets, the diaphragm is shellacked to the face of this gasket, the second rubber gasket is slipped into place and then the screw bezel is screwed down until the diaphragm is held securely in position.

The needle bar is now placed into position on its pivots, and when these are tightened so that there is no side motion in the arm the little lock nuts on the pivot screws are tightened up against the frame.

Placing the little washer and nut on the end of the needle bar and screwing them up tight against the mica completes the assembling and the sound box is ready for use.

PLACED LARGE RECORD ORDERS

Miss M. Anderson, manager of the record department of the Crary Hardware Co., Boone, Ia., recently paid a visit to the Mickel Bros. Co., the Victor wholesalers in Des Moines, Ia., and left a large order for records.

USE AUTOMOBILE IN SERVICE

How New York Talking Machine Co. Co-operates With Sales Force—J. H. Bieling Rejoins Company—Recent Visitors to New York Office—Makes Plea for Deliveries

In order to enhance the efficiency of its sales staff the New York Talking Machine Co., Victor wholesaler, recently purchased an automobile for its New England traveler, Fred Stewart. Mr. Stewart will now be in a position to call upon his dealers with maximum convenience and thereby give them an even greater degree of service and co-operation than he has during the past.

During the past few weeks Roy J. Keith, manager of the New York Talking Machine Co., has received several letters from the company's dealers expressing their pleasure at the fact that John H. Bieling has rejoined the company's sales staff. This veteran of the Victor industry has already renewed the friendship of the dealers in his territory, who are glad to welcome back this popular old-timer.

Quite a number of out-of-town dealers called at the offices of the New York Talking Machine Co. during the past fortnight to make a unanimous plea for the shipment of merchandise and to verify the fact that the demand for Victor products in their territories exceeds all previous totals. Among these callers were Stiles Clinton, of the A. B. Clinton Co., Hartford, Conn.; Wm. C. Heim, Danbury, Conn.; James Donnelly, South Norwalk, Conn.; A. P. McCoy, Fulton-Driggs-Smith Co., Waterbury, Conn., and Mr. Kern, of the Kern Music House, Providence, R. I.

SON OF E. A. GEISSLER DEAD

Edward P. Geissler, Former College Athlete, Passes Away in Los Angeles

LOS ANGELES, CAL., November 4.—Pneumonia last Thursday, October 31, claimed as a victim Edward P. Geissler, formerly one of Stanford's best-known athletes, and one of the all-star American football team that went to Vancouver in 1912. Mr. Geissler, the son of E. A. Geissler, vice-president of the George J. Birkel Co., was twenty-seven years old. He lived at 4843 Rosewood avenue, and leaves a widow, Mrs. Clara Louise Hollan Geissler, and two children, Edward B., five years old, and John H. Geissler, aged one year and six months.

Mr. Geissler was born in San Francisco, but spent most of his life in Los Angeles. He attended the Los Angeles High School and Stanford University. On returning to Los Angeles from Stanford Mr. Geissler enrolled in the College of Law of the University of Southern California, and became a member of Phi Delta Phi Fraternity. In addition he was a member of the Los Angeles Athletic Club, and the First Methodist Episcopal Church. He was associated in business with Wheeler Bros. & Pierce Co.

Talking Machine Hardware

We manufacture hardware for all styles of cabinets

Lid Supports
Needle Cups
Needle Rests

Door Catches
Sliding Casters
Continuous Hinges

Sockets
Tone Rods
Knobs, etc.

BEST QUALITY

LOWEST PRICES

WEBER-KNAPP COMPANY

Jamestown, N. Y.

WAR SERVICE COMMITTEE REPORTS ON PRIORITIES RULING

Advises Industry of Regulations Under Which It Must Operate for the Time Being—Excellent Arguments Presented at Washington—The Order of the Priorities Division

There has just been sent to the members of the talking machine manufacturing trade a most comprehensive report of the efforts put forth before the Priorities Division of the War Industries Board by the War Service Committee in behalf of the industry, and the very favorable rulings of the Priorities Division following the presentation of arguments by Chairman H. L. Willson, of the War Service Committee.

The committee, in addition to Mr. Willson, the chairman, includes: A. L. Cushman, of the Emerson Phonograph Co.; Charles Edison, Thomas A. Edison, Inc.; Ralph L. Freeman, Victor Talking Machine Co.; Joseph Schechter, of the Sonora Phonograph Corp., and secretary of the committee; and Eugene A. Widman, Pathé Frères Phonograph Co., all of whom attended the meetings before the Priorities Division, and also W. H. Alfring, of the Aeolian Co.; Julius Balke, Brunswick-Balke-Collender Co.; L. Mandel, Mandel Mfg. Co., and L. Rommel, of the Bell Phonograph Corp.

The committee first secured recognition from the Chamber of Commerce of the United States, as representing officially the talking machine industry, and on September 14 appeared before the Priorities Division of the War Industries Board, Judge Parker presiding, to present its arguments in favor of the industry.

The arguments of the committee were presented in the form of a brief by H. L. Willson, and he took occasion, first, to emphasize the part that phonograph and phonograph records are playing in maintaining the morale of the soldiers and sailors, in the camps, on the field and on ships. He called attention to the fact that after four years of war England refused to curtail the phonograph industry, and that Lloyd George had particularly requested that that industry be not interfered with.

In the relation of the phonograph industry to other industries Mr. Willson stated that phonographs of a sales value of approximately \$45,000,000 annually used but 12,000 tons of steel and less than 85,000 tons of coal, and that the iron and steel entering into the manufacture of phonographs was approximately only 5 per cent. of the total value thereof. He gave a list of the iron and steel on hand at the time, as well as the amounts of those metals required, and stated that much of the material on hand would be useless without supplies of other parts. He also stated that more than 50 per cent. of the factory employes were women, and a large part of the remainder in some factories were enemy aliens and not permitted to work in munition plants.

In the brief the fact is emphasized that most of the large manufacturers are, in most cases, in the East, and that a great percentage of their product is shipped West, and that inasmuch as a large percentage of cars are said to go West empty, the hauling of phonographs does not interfere with transportation, but makes a Western haul a profitable one to the railroads.

Mr. Willson outlined the manner in which England had handled the phonograph industry in the matter of restrictions; realizing that that industry was important and essential and giving it consideration on that basis. He quoted newspaper editorials, and expressions of opinion from Major-General J. Franklin Bell, Commander of the Department of the East, and prominent men connected with the various war activities of the Y. M. C. A., War Camp Community Service, as well as official song leaders, to prove the absolute necessity of music in preserving the morale and keeping up the spirits of the fighting men. Facts were also presented to show what music, and particularly talking machine music, is doing for the education of the people at home, and in keeping up their patriotism. A special point was made of the work of the phonograph in carrying on Americanization work among foreign-born residents, and particularly their children

through the medium of the schools, and other agencies.

The brief was exhaustive and convincing, and its presentation resulted in the issuance of the following ruling by the Priorities Division, listed as Circular No. 39, and addressed to the talking machine industry.

Ruling of Priorities Division

"Following conferences with your representatives, the Priorities Division has reached conclusions as follows:

I

"Any of your manufacturers who desire to be placed upon the preference list which has been prepared by this division may obtain forms therefor from, and make application to, the secretary of the Priorities Board. Any such applications will receive consideration.

"The preference list is the guide to all Governmental agencies and others interested in

"The production and supply of fuel, and electrical energy, the supply of labor and the supply of transportation service by rail, water, pipe lines, or otherwise, in so far as said service contributes to the production of finished products."

"Priorities in the 'supply and distribution of raw materials, semi-finished and finished products' are not governed by the preference list, but by priority certificates and automatic ratings described in Circular No. 4 and its supplements issued by this division.

II

"Your industry can supply essential needs during the last four months of 1918 if you can obtain certain limited quantities of materials which have been discussed with your representatives and if such materials are properly distributed among your manufacturers with a view to balancing and equalizing stocks. This division will issue to any of your manufacturers desiring its distributive portion of such quantities of materials Industry Priorities Certificates authorizing them to purchase its quota of such materials under the following conditions:

"1. Such manufacturer will file with this division its pledge as follows:

"The undersigned hereby pledges itself for the period from September 1, 1918, to December 31, 1918, (1) to use only in the manufacture of talking machines, talking machine motors and talking machine accessories and parts therefor the materials suitable therefor which are now in its possession or which may hereafter come into its possession (other than materials required or reserved for making other products covered by priority certificates or automatic ratings); (2) to reduce its consumption of iron, steel, copper, brass and aluminum used in the manufacture of such products to a basis of not exceeding 40 per cent. of four-twelfths of its 1917 consumption of such materials; (3) to comply with the regulations of the Conservation Division of the War Industries Board as to economics and substitutions."

"2. Such manufacturer will file with this division its statement under oath showing:

"(a) Quantities (by weight) of iron, steel, brass, copper and aluminum, and all products of such materials used by it in producing its 1917 output of talking machines, talking machine motors and talking machine accessories;

"(b) Quantities (by weight) of such materials and products of such materials in stock, in storage, and in transit owned by such manufacturer on September 1, 1918, or held for it;

"(c) Quantities (by weight) needed to balance stocks, but only so far as needed in connection with existing stocks to manufacture the output of talking machines, motors and accessories and parts therefor mentioned in its pledge.

"3. When the pledge and affidavits mentioned have been filled and Industry Priority Certificate issued it will take Class C rating and orders placed according to its provisions and this circular may be filled. No formal application for

Industry Priority Certificate is required. No guarantee can be given your industry that the material called for in any certificate can be supplied.

III

"Copper, brass and aluminum are so urgently and immediately needed for war purposes in quantities beyond the available supply that you will be expected to discontinue their use in any form in the manufacture of your products. This regulation, however, will not be construed as forbidding you to hold such quantities of materials as you now have on hand unless you may be asked to release such materials for the war program.

"Practically all of the materials which are used by your industry are of such importance and the constantly increasing demand for them is so vast that your industry should make every effort to avoid any unnecessary or wasteful use of any of such materials. After the war demands are met, there will be comparatively little left of the most important materials which you use to distribute to industries engaged in producing non-war products. It cannot be determined at this time what allotments may be made at the expiration of the period covered by the present allotments. Your success in accomplishing real and substantial reductions in your consumption of such materials and in prevailing upon consumers to postpone and reduce their demands for such products will contribute materially to the nation's welfare and will be a factor in measuring your further allotments. Yours very truly, Edwin B. Parker, Priorities Commissioner."

In submitting the report the War Service Committee through Chairman Willson says:

"Our country's needs are great and imperative under the stress of war requirements, and we believe, therefore, that you will cheerfully accept the curtailments and economies imposed by war conditions, and prescribed by Governmental bodies on our industry."

[See latest order of Priorities Commissioner, increasing metal allowances, on page 110.]

BROOKS AUTOMATIC REPEATING PHONOGRAPH



THE WONDER INSTRUMENT

Plays and repeats any kind or size record—any desired number of times—then stops automatically with the tone arm suspended off to the right in the air. Any child can operate it.

WONDERFUL TONE WONDERFUL FINISH
WONDERFUL IN ITS SIMPLICITY

The Machine Creates Interest and Discussion.

It is Self-Advertising

WONDERFUL SELLER

DEALERS—Send for Particulars, Prices, Terms.

BROOKS MFG. CO., Saginaw, Mich.

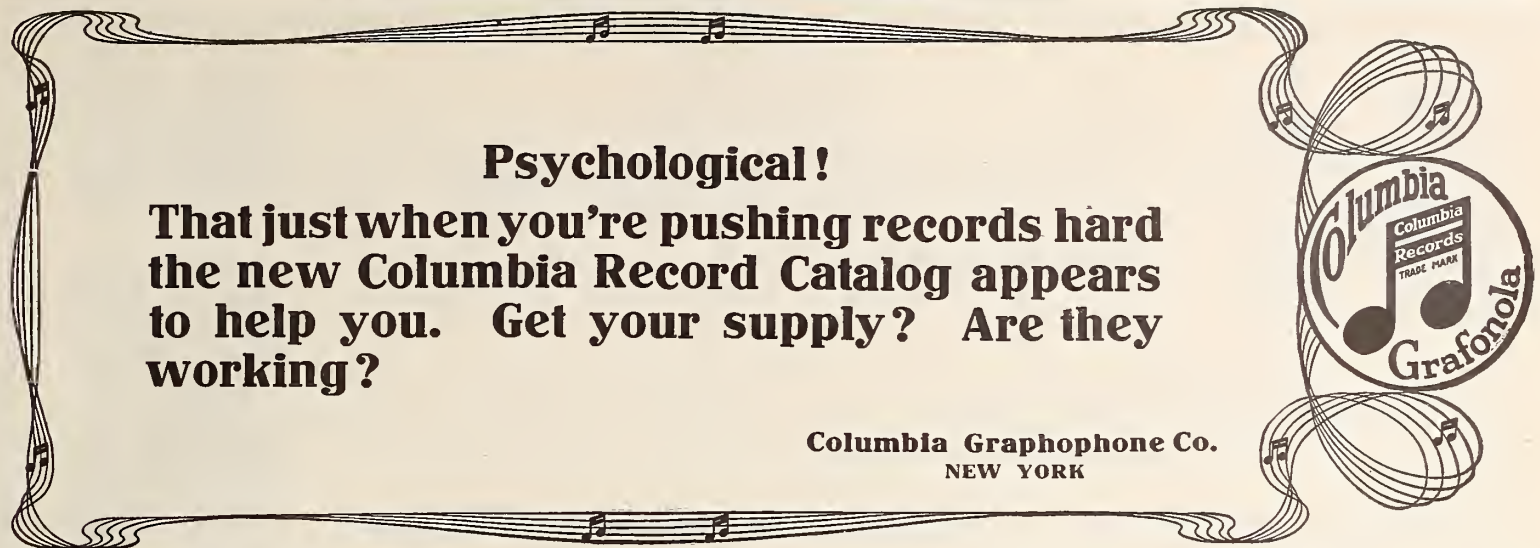

Psychological!

That just when you're pushing records hard the new Columbia Record Catalog appears to help you. Get your supply? Are they working?

**Columbia Graphophone Co.
NEW YORK**

ST. LOUIS DEALERS COLLECTING RECORDS FOR SOLDIERS

Talking Machine Men Send Their Wagons to Gather Slacker Records—The Stock Situation a Puzzle to Many—The Jobber's Problem—What the Local Factories Are Doing

St. Louis, Mo., November 9.—The talking machine business has gone through the Liberty Bond, an influenza quarantine and other handicaps during the past month and comes out with a clean selling score. Practically all dealers will tell you that their business could not be better without more stock. Every dealer in town is complaining that the models he best likes are short. At the jobbing houses they tell you that they are doing fairly well, but that certain models are somewhat short. It has gotten to the stage where the jobbers make no bones about being short, and in most cases they openly admit that their chief trouble now is getting enough of the popular models at one time to enable them to make proportionate distribution of the orders on file.

But with the records it is different. They are coming through in fair numbers, and, better than that, the people are catching the spirit of the thing and are willing to buy records that are new to them but which are old on the lists. It has been beneficial to the trade, in this respect, that much has been published about this and that trade being restricted to gain materials and men to win the war. People like to think that the talking machine trade is doing its part and they are willing to be a bit more patient about getting really new numbers. Others who are not so patient often can be sold by skilfully finding out if they have heard this record by that artist and then presenting the record as a new one. As long as the purchaser is happy, there is no harm done and there is one less person growling about the hardships of whipping the Germans.

It might appear to be an easy question to answer, but is there an actual shortage of talking machines (quality not considered)? The World correspondent has asked this question of a dozen dealers within the last few weeks and each dealer has his own ideas on the subject. When you get down to detail no two exactly agree.

All agree that there is a shortage of standard make and quality talking machines. That question admits of no doubt in the minds of most dealers. Some think there is an actual shortage of all kinds of machines, but one job-

ber gave it as his opinion that if every person now willing to buy a talking machine could be persuaded to buy regardless of make each would be accommodated, and that there would be some left in the stores.

Another jobber whose machines are sold in a number of stores said: "I have been trying to estimate the shortage of certain styles of our cabinet machines, but am puzzled. It is like this: A reported to me the other day that he could sell ten of our Style Q machines. B, whose store is in the same part of the city and in many ways similar, tells me that he could sell a dozen Q machines. This is repeated in all parts of the city. Now the question that is bothering me is how often is the demand for a single machine repeated. I am satisfied that A and B are dealing with some of the same prospective buyers. But how many duplicates? My investigations would indicate that there are three duplicates in these two reports, which would mean a demand for nineteen machines instead of the apparent twenty-two. But there may be other duplicates by reason of several persons in the same family inquiring. It is beyond me. I know that there is a shortage of our machines and we have not even a sample in our jobbing warerooms of an obsolete cabinet machine. We have offered to take any sticker off the hands of any dealer. That is how nearly we are cleaned up. We have a few box machines and a few of current styles, just in."

The local dealers have been giving much attention to the collection of slacker records for the soldiers. Their goal was 100,000. The campaign was handled by F. L. Liebing, manager of the musical bureau of the Kieselhorst Piano Co., which store was the headquarters. A room at the store was set apart for handling the collection and before the drive began one of the Kieselhorst record saleswomen was busy taking care of the early arrivals.

The following dealers caused to be published a large ad offering the services of their stores and delivery systems for the collection of soldier records. The following signed the ad (and paid for it): The Aeolian Co., 1004 Olive street; the Artophone Co., 1113 Olive street; Barthels & Dusenber (Concordia Music House), 912-14 Pine street; F. Beyer & Son, Seventeenth and Locust streets; Boehl Furniture Co., Grand and Gravois avenues; Field-Lippman, 1120 Olive

street; Hunleth Music Co., 515 Locust street; Kieselhorst Piano Co., 1007 Olive street; Klee-kamp Bros. Piano Co., 3121-23 South Grand avenue; Larkatone Music Co., Inc., 3749 South Jefferson at Broadway and Chippewa; Murmann Phonograph Co., 1318 Olive street; Roesch Furniture & Carpet Co., 1543 South Broadway; 417 West Schirmer street; Silverstone Music House, 1114 Olive street; Smith-Reis Piano Co., 1005 Olive street; Thiebes Piano Co., 1006 Olive street.

It is not detracting from the service of the talking machine dealers in this work to say that they are already reaping some reward for their zeal. Some persons bought new records to send to the soldiers, but a larger class who had quit buying, or had become very conservative buyers, have enlarged their operations. "We did not like to buy more while we had 200 records at home, but we gave away 100 of the popular ones to the soldiers and now we will buy some more," said one customer, and in certain degrees this remark was repeated dozens of times.

Manager Chrisler, of Aeolian Hall, who has taken over the management of the wholesale Aeolian-Vocalion department, reports a most excellent trade in various sections of the country. "We are now seeking to protect our established dealers rather than taking on new dealers," he said, "but where a dealer is willing to consider the styles that we have most of, we let him have some stock to introduce our line." The Lehman Music House, of East St. Louis, and John M. Taylor, of Macon, Moberly and Columbia, Mo., are recent Vocalion dealers.

Retail Manager Brandt said that he was chiefly surprised at the small effect the influenza ban

(Continued on page 98)

Record Delivery Envelopes
Safe - Swift - Secure

The heavy paper means protection; the button and cord mean speed — you can wait on more customers.

Bring out YOUR OWN NAME. Every time an envelope leaves your store, let the advertisement on it take your name to the homes and bring new trade. The advertising more than pays for the envelope. Write for samples and prices.

Lewis C. Frank, 694 Book Bldg., Detroit

"NICHOLSON"
New Catalog Showing New Styles
RECORD CABINETS
strictly high-grade construction at prices
BELOW COMPETITION

Write for a copy of the catalog and our special free advertising help for dealers.

K. NICHOLSON FURNITURE CO., Chase City, Virginia
Sectional Bookcases and Record Cabinets

Walter S. Gray
Chronicle Bldg., San Francisco, Cal.

**N
E
E
D
L
E
S**

Pacific Coast Jobber for the Best in
Talking Machine Trade Accessories



No. 103

SOSS

INVISIBLE HINGES

Preserve Beauty

In many beautifully designed, finely finished Talking Machines, Pianos, Music Cabinets, Piano Players and Benches, the elimination of the unsightly protruding Hinge is essential to preserve the beauty of the design.



No. 100



No. 101

WRITE FOR CATALOGUE "T"

SOSS MANUFACTURING COMPANY,

DETROIT—922 David Whitney Bldg.
SAN FRANCISCO—164 Hansford Bldg.

435 Atlantic Avenue, BROOKLYN, N. Y.

LOS ANGELES—600 Metropolitan Bldg.
CHICAGO—John C. Bold & Co., Clark and Washington Sts., Conway Bldg.

COLLECTING RECORDS IN ST. LOUIS

(Continued from page 97)

had shown on sales totals. "With an encouraging number of machines in stock we could have met all previous expectations, but as it is we have exceeded expectations, circumstances considered. The record business appears to be almost without limit these days. People have money and are buying not only popular music, but the most expensive records."

Manager Roos, at the Columbia wholesale branch, would like to employ a man or woman who can put talking machines into fractions and satisfy the trade. "Our organization is well settled in an excellent stride and we are handling all the business that we are permitted in fine shape. Our dealers report that they are holding many prospects until the time that they will have Columbias for them," he said. "It is in time like these that reputation pays an excellent investment."

C. D. Westervelt, who formerly was with the Aeolian Co. at Boston, has joined the Vocalion staff here.

The decorators were in charge at the Artophone Co., where a good deal of attention is being given to the retail trade. The entire first floor has been quite handsomely fixed up and President Cone says that the brighter sales-room already is proving a good investment and that it and the improved Artophone is a combination that is hard to beat.

Mark Silverstone, of the Silverstone Music Co., says that he believes that his company will make very fair distributions of machines before the holidays, as the shipments now in sight will relieve the most acute shortages. The records, he says, are coming through nicely and the company is now meeting all of the increasing demands.

President Fitzgerald, of the Mozart Co., reports that his factory is busy chiefly on essential work and the talking machine output at present is only such as can be made when the machinery is not on strictly war work.

"We have been making very fair deliveries of Pathé instruments," said Manager Staffelbach at the Hellrung & Grimm Furniture Co., "and

we expect to have all of our back orders filled before Christmas. We have been able to accomplish this by cutting off some dealers who were not coming up to the expected standard and we are not taking on any new accounts that interfere with supplying old customers. Our totals are making a most excellent showing, better than we expected to make. Our record business is without precedent."

MUST LOOK OUT

Credit men, both wholesale and retail, are not going to have an easy time of it during the reconstruction period that will follow the ending of the war, according to one of the best-known credit grantors in the city. The wholesale credit man will have the harder job of the two, he said, for he will be dealing with merchants who will have to conduct their business in the face of a declining market, and who will have to "watch their step" pretty carefully in order to avoid the bankruptcy court. As for the retail credit grantor, he asserted, his problem will lie in good part in guarding against defaulted payments on the part of the many customers who are getting their prosperity out of the war and who ordinarily would not be considered good risks. The situation is one that must be carefully watched by all concerned. We must move slowly and cautiously.

AN EMERSON RECORD DEPARTMENT

One of the reasons for the big success of dealers handling Emerson records is the original and attractive displays used and the establish-

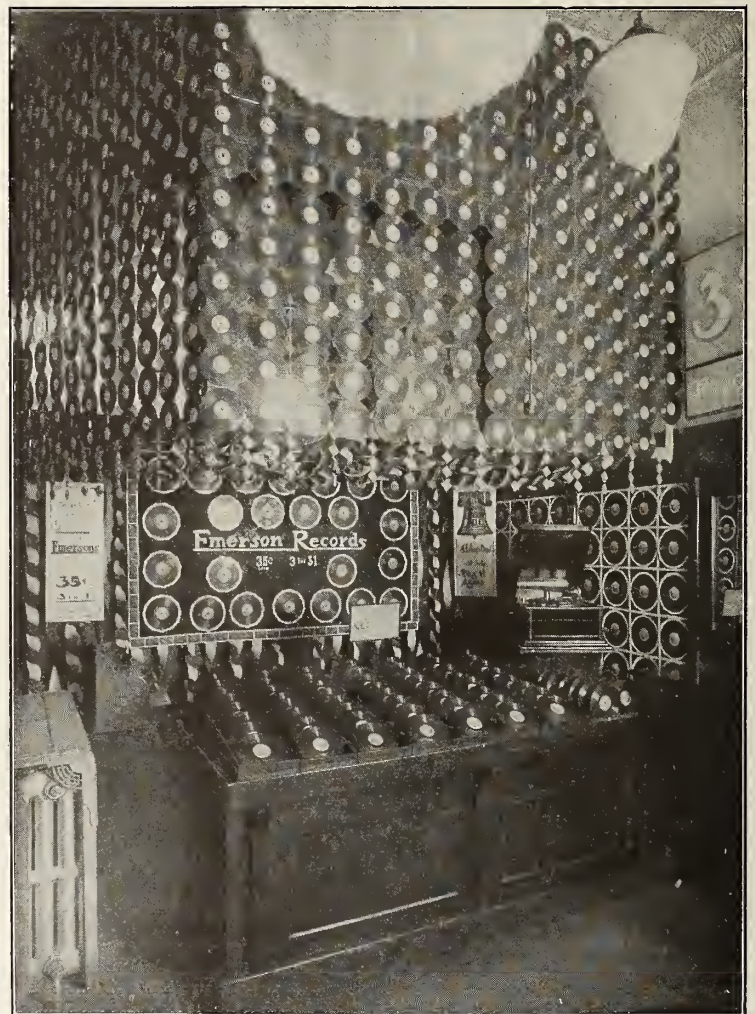

Interior Display Made by the S. S. Kresge Store, Indianapolis, Ind.

ment of a really high-class record department. This interior display is from S. S. Kresge, Indianapolis. It not only won a prize in a recent Emerson record display contest, but also sold a great many records to new customers.

EDISON CHRISTMAS SUPPLEMENT

List of Blue Amberol and Royal Purple Releases for December Just Issued

An excellent Christmas supplement of Edison Blue Amberol and Royal Purple records has just been issued by Thos. A. Edison, Inc., which contains several exceptionally high-class recordings by such artists as Arthur Middleton, Frieda Hempel, P. A. Asselin and other equally well-known Edison artists. The numbers range from sacred songs, especially appropriate at Christmas time, to lighter ballads and popular songs, besides several instrumental numbers.

**BUY YOUR ALBUMS
DIRECT FROM
THE MANUFACTURER**

Pat. Dec. 15, 1914

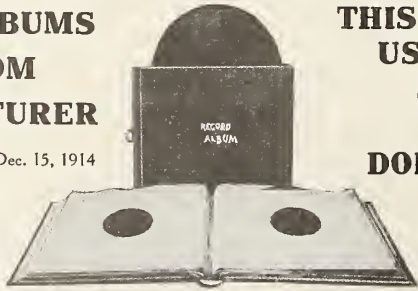

**THIS ALBUM MADE
US FAMOUS BY
SELLING IT.
WHY
DON'T YOU TRY?**

BOSTON BOOK COMPANY, Inc.

43-51 Fourth Avenue, New York, N. Y.

BUSINESS IS GOOD

But

You and I Are Here to Make It Better



Attractive
Proposition
for
Dealers
and
Jobbers

Write To-day

THE ART CRAFT
LINE of Talking
Instruments is a true
exemplification of the
QUALITY for which
Grand Rapids Furni-
ture is internationally
recognized.

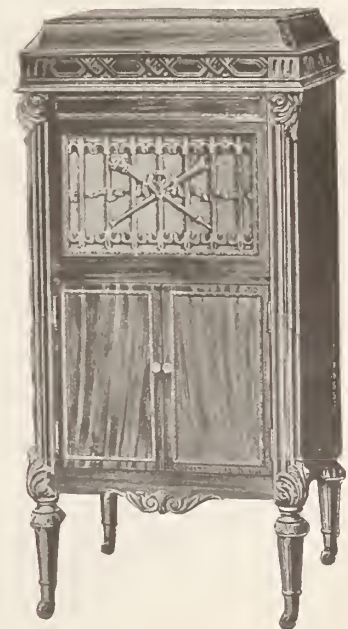

Six
Art Models
\$140.00
to
\$350.00

The Art Craft Company

MANUFACTURERS OF

The Art Craft Line

PHONOGRAPHS

GRAND RAPIDS, MICHIGAN

BUSINESS UNUSUALLY ACTIVE IN SOUTHERN CALIFORNIA

Despite Many Untoward Influences Los Angeles Trade Was Most Satisfactory During the Past Month—Record Demand Shows Remarkable Strength—Machine Shortage Is Still Most Pronounced

LOS ANGELES, CAL., November 4.—The month of October was rather strenuous for Los Angeles in more ways than one. In fact, it was really remarkable how well business kept up in spite of the Liberty Loan and the influenza. The indications are good for business during November.

The shortage of leading makes of machines and records is still acute with no promise of bettering the present condition before the first of the year. All local dealers are making desperate efforts to bolster up their fast depleted stocks, but with little or no success.

The demand for "war" songs seems to be increasing in spite of the numerous ones coming out every month, and the sales are still running big on such pieces as "Keep the Home Fires Burning," "Just a Baby's Prayer at Twilight," "Over There" and "Joan of Arc."

The Purchasing Agents' Association, of Los Angeles, gave a delightful banquet at the Sierra Madre Club on the evening of October 4. The most enjoyable thing on the program in the way of entertainment was a demonstration of the Edison Diamond Disc by Howard Legge, of the Southern California Music Co. Popular war songs were featured on the machine, which was a laboratory model of the William and Mary design, and during the evening those present sang a new version of "Keep the Home Fires Burning," led by the Edison machine. Mr. Legge gave a short talk on the Edison and its possibilities.

Colonel George P. Filmer, Pacific Coast division director for the Red Cross, purchased three of the Edison Army and Navy model machines for three of the cantonments. This model is a favorite with the soldiers and sailors.

W. S. Stidham, local manager for the Columbia Phonograph Co., says that during October

more Columbia records were also sold than ever before in any one month in the territory of the Los Angeles branch of the Columbia Graphophone Co.

The Southwest is the Land of Sunshine and Flowers—it also aspires to be one of song. The scarcity of Grafonolas evidently inspired the dealers to drive on records. They had excellent material to work with both on the "special" lists and the regular October records.

The death, somewhere in France, of Gus Schiresohn, youngest brother of the well-known North Main street talking machine dealer, Max Schiresohn, proprietor of the American Jewelry Co. and Schiresohn Bros., has stirred the sympathy of their many friends.

Nathan Milnor, formerly general sales manager of the Dictaphone, visited the California Graphophone Co.'s headquarters at 745 South Broadway, en route for San Francisco, where he is assuming the management of that branch as successor to F. A. Dennison.

Mr. Humphrey, recently manager for Byron Mauzy, San Francisco, has been appointed manager of Hamburger's Grafonola department.

George W. Lyle, assistant to the president of the Pathé Frères Phonograph Co., visited Los Angeles in October.

J. L. George, manager of the talking machine department for the Mercantile Co., of Long Beach, Cal., was in the city recently acquiring stock for Christmas. Mr. George says business is good at the beach town and the enlargement of all the shipbuilding plants has brought thousands of workmen to the city who are all good prospects for machines.

Beginning Sunday, October 24, 1,000,000 records, talking machines and small musical instruments are to be assembled throughout the country by the National Phonograph Record

Recruiting Corps to be sent to men in service. In Los Angeles there will be two committees, the general committee, with Marco Newmark as chairman, and the campaign committee, with Miss Rena MacDonald at the head.

ADVERTISING VOCALION RECORDS

Featured in a Big Way in Announcement in the Saturday Evening Post

The Aeolian-Vocalion phonograph and Aeolian-Vocalion records were featured to excellent advantage last week in a full-page advertisement that appeared in the Saturday Evening Post. The attractiveness and artistic beauty of this advertisement was enhanced by the fact that it appeared in several colors, and this page was one of the finest talking machine advertisements that any national advertiser has used recently.

The page featured the new Vocalion records made by Giulio Crimi, the leading Italian tenor of the Chicago Opera Co., who is an exclusive Vocalion artist. The Vocalion record "On With the Play" from Pagliacci has achieved phenomenal success, and this advertisement called attention to the musical qualities of this record.

The Aeolian-Vocalion phonograph presented in this page was the Vocalion Style "I," retailing at \$225, which is one of the most popular instruments in the Aeolian-Vocalion line, and which is meeting with signal success throughout the country.

TALKER MEN GOLF CHAMPIONS

DES MOINES, IA., November 4.—The recent golf match to determine the championship of Des Moines was decided in favor of the team representing the Mickel Bros. Co., Victor wholesalers, and consisting of W. P. Beal, manager of Mickel Bros. Co.; H. B. Sixsmith, traveler, and Earl Haglund, manager order department, which won out against the Southern Surety team.

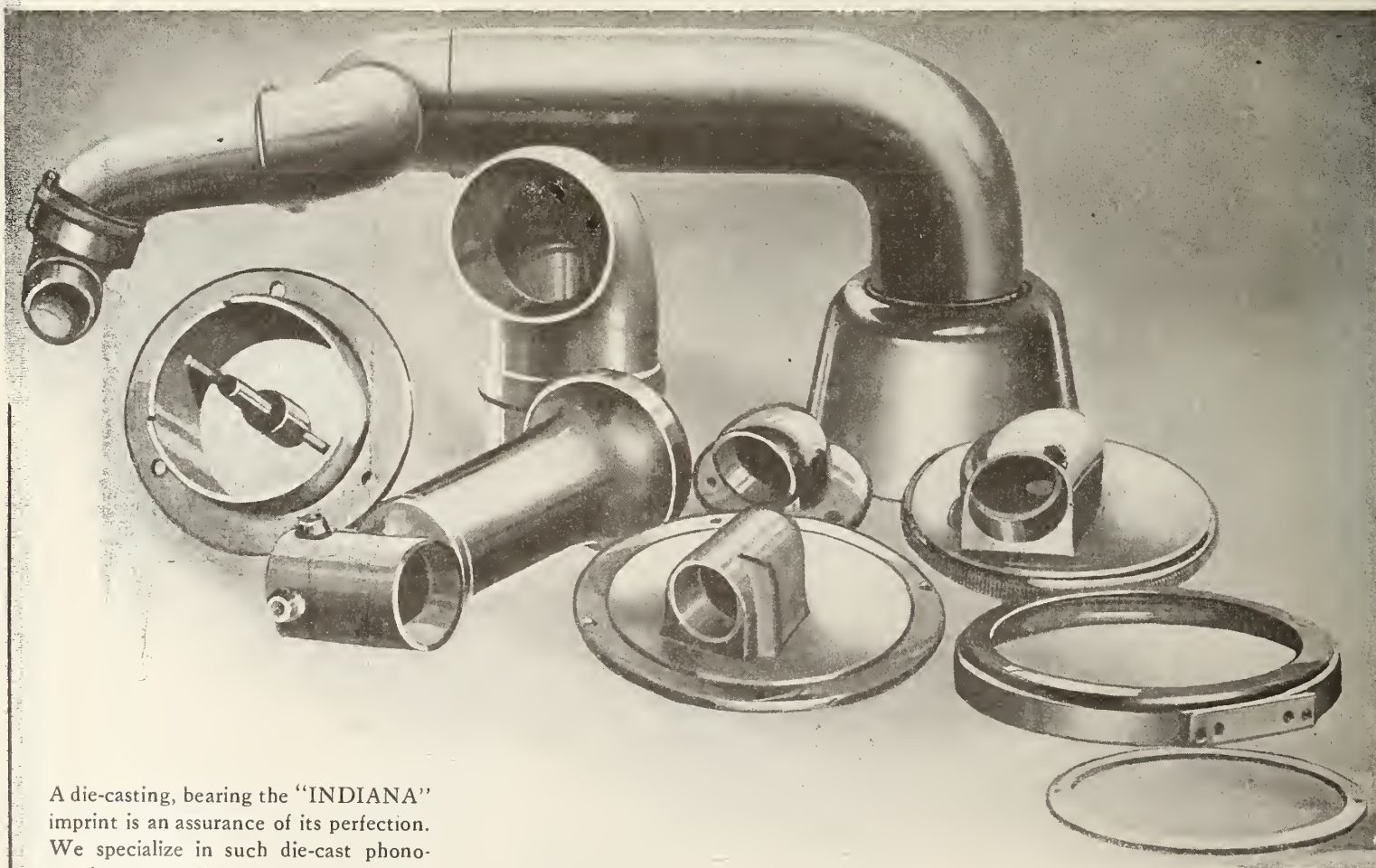

A die-casting, bearing the "INDIANA" imprint is an assurance of its perfection. We specialize in such die-cast phonograph parts as shown above.

"INDIANA" DIE CASTING CO.
 CORNELL AVE., at 11th ST. INDIANAPOLIS, IND.

FLOOR TAX CLAUSES KILLED

Section of War Revenue Bill Providing for Tax on Stocks in Hands of Manufacturers, Wholesalers and Retailers Is Removed

It was announced this week that after a strong fight by the music trade interests and others Sections 909 and 910 of the new War Revenue bill, providing for a collection of a floor tax of 10 per cent. on all musical instruments in the hands of manufacturers, wholesalers and retailers, had been eliminated from the bill. The proposed floor tax in the new bill differed from that existing in the present War Revenue Act in that its provisions were extended to cover retailers. The danger of the floor tax was early recognized, and strong arguments were immediately brought to bear on the Finance Committee, it being pointed out that the excess tax of that sort against a retailer with a large stock of goods on hand would in some cases threaten bankruptcy. It is not believed that an attempt will be made to reinsert the same clause or put a similar one into the bill before it is finally signed and becomes a law.

NEW COLUMBIA RECORD ARTIST

Miss Barbara Maurel, Mezzo-Soprano, Joins the Recording Staff of That Company

The Columbia Graphophone Co. announced this week the addition to the Columbia recording library of Miss Barbara Maurel, a mezzo-soprano, who has achieved great success on the concert stage and in operatic circles. Miss Maurel will record exclusively for the Columbia record library, and her first records will be announced very shortly.

Miss Barbara Maurel, who was born in Alsace-Lorraine, studied abroad under Jean De Reszke, and her season with the Boston Opera Co. won the praise of the leading critics. Musically speaking, she follows the traditions of the French school, and it is said by recognized authorities that her voice is remarkably adapted for recording purposes. Miss Maurel specializes in the rendition of old-time ballads, and her Columbia records will doubtless meet with a hearty welcome.

W. L. MULVANEY NOW IN CHARGE

DUBUQUE, IA., November 4.—Walter L. Mulvaney, formerly manager of the Victor department of the Geo. W. Wheelock Co., Peoria, Ill., has taken charge of the Victor department of Roshek Bros. Co., this city. This concern have just moved their department from the third floor to the second floor and have installed a modern three-booth department. The booths are finished in white enamel with French windows, and the whole department is covered with heavy green velvet carpet. A. Reh, the general manager of the store, has received many compliments on the installation.

TALKING MACHINE INDUSTRY GRANTED INCREASE IN METAL ALLOWANCE FROM 40 TO 70 PER CENT

Favorable War Developments Move Priorities Commissioners to Give Quick Relief to Talking Machine Manufacturers—Order Reflects Attitude of Government Towards Business

H. L. Willson, Chairman of the War Service Committee of the Talking Machine Industry, received the following telegram from Edwin B. Parker, Priorities Commissioner, on Monday, November 11, in which the industry is advised that the ruling restricting the use of metal for talking machines to 40 per cent. of the 1917 consumption has been amended to permit the use of 70 per cent. of metals. The telegram, which in itself is explanatory, reads:

"Account favorable war developments restrictions on talking machine industry, including motors and accessories, embodied in Circular No. 39, Priorities Division, are hereby so modified that for the last four months of 1918 the consumption by said industry of iron, steel, copper, brass and aluminum used in the manufacture of its products will be on basis of not exceeding 70 per cent. of four-twelfths of its 1917 consumption, instead of 40 per cent. as provided in said Circular. In all other respects rules and regulations remain in full force and effect. Please notify all members of your industry."

The receipt of the telegram on the day that the signing of the armistice with Germany was formally announced is accepted by talking machine men as an indication of the favorable manner in which the industry is regarded in Washington, and likewise an indication of the attitude of the Government in the matter of granting industries relief from restriction as soon as possible. The original priority order limiting the use of steel and other metals to 40 per cent. of 1917 consumption was only issued, and had hardly become operative before the allowance was increased to 70 per cent.

It is also reported that the Priorities Commissioner has issued an order permitting an increase in steel needle production from 50 per cent., as it now stands, to 75 per cent., thus providing great relief for the industry as a whole.

ASK DEALERS' CO-OPERATION

National Phonograph Records Recruiting Corps Tells of Results Achieved in Drive for Records—Why Work Must Continue—Its Effects

The National Phonograph Records Recruiting Corps advises The World that reports received at headquarters at 21 East Fortieth street, New York, prove that the mark set for the collection of over a million records in the recent drive was not only reached, but passed by tens of thousands of records, and that the results accomplished were largely due to the hearty co-operation of the talking machine dealers.

Major-General Bell, U. S. A., the honorary chairman of the national committee, has just pointed out that this drive was only the start of the movement, and the quest for machines and records will go on until the last of our troops have returned to these shores and have been demobilized. Now that the war is ended the need for wholesome entertainment for our fighting men is more imperative than ever, for, as General Bell states, a million or more of our men will be required in Europe for a year, perhaps two, on police duty, hence the continued demand for music not only abroad but also at home, where the process of demobilization will necessarily be slow.

Army and navy officers are tremendously gratified by the extraordinary success of the slacker record drive, and have urged the corps to maintain a steady supply of talking machines and records until demobilization is complete. Therefore most of the five hundred local committees throughout the United States have agreed to continue their work indefinitely so

that the number of records to be collected will more likely reach the total of two instead of one million.

In view of this it is essential that talking machine dealers should continue their activities and co-operation. Somewhat more than 40 per cent. of the dealers throughout the country have become members of the Phonograph Record Recruiting Corps Trade Auxiliary, and others are urged to join.

In a recent letter to the dealers the national committee points out that the trade cannot fail to benefit in a material way by this co-operation, because millions of records will be donated, thus stimulating the purchasing of new ones; countless future buyers will be created in the army and navy, and popular and official recognition of the essential nature of the talking machine business will be accelerated, to the general benefit of the industry.

Dealers are asked to send at once to their local committees or to the New York City office, 21 East Fortieth street, a statement of the number of records and machines collected or purchased, so that a complete tabulation of the material in the district can be made without delay.

HOLD HALLOWE'EN PARTY

The employes of the Victor department of Chase & West, Des Moines, Ia., recently held an old-fashioned Hallowe'en party, with bobbing for apples and all. In that contest the honors were divided between Chase West, manager of the department, and Miss Golda Airy, manager of the educational department. As the saying goes, "a good time was had by all."



VICTOR RETAILERS

Are You Getting This Valuable Monthly Sign Service?

23 CARDS { 1—22x28 SHOW CARD
2—11x14 SHOW CARDS
8—RECORD EASEL SIGNS
11—PRICE TICKETS
1—WINDOW POSTER } **for only \$3.00 PLUS POSTAGE PER MONTH**

Canadian price \$3.50 plus postage and duty.

Send for a trial set and be convinced of its exceptional value and window decorative qualities. We also manufacture the new "CARDO" imitation records and fancy papers for window trimming purposes. **Ask Your Wholesaler.**

ED. USOSKIN INC.

PRINTERS & LITHOGRAPHERS
230 W. 17th St., New York City

PEACE

HE Glad Tidings have been spread over the world. The din and roar of battle, the noise of firing cannon and the shouts of charging men have ceased. Over the war-torn field has fallen the quiet of Peace.

To the dead that lie, cold and stiff, in Flanders fields, we pay tribute. They asked us to take up the quarrel with the foe. They threw to us the burning torch and bid us hold it high. They left to us the task of securing a Peace which would exact unbreakable guarantees that faith shall be kept.

And with this Peace inscribed upon the great tomb wherein they lie, with the poppies showing red again in Flanders fields, we have answered. We have held high the burning torch and held sacred their faith in us. They have not suffered and died in vain.

We are proud of the small part it has been our rare privilege to play. we thank our friends who have so loyally and so patriotically understood conditions.

And we face the To-morrow, the readjustment period between war and peace, with faith, with hearts filled to over-flowing and a prayer of thankfulness upon our lips.

Cordially yours,



Vice-President

STEPHENSON, INC., One West 34th Street, New York

Manufacturers of the Stephenson Precision-Made Motor

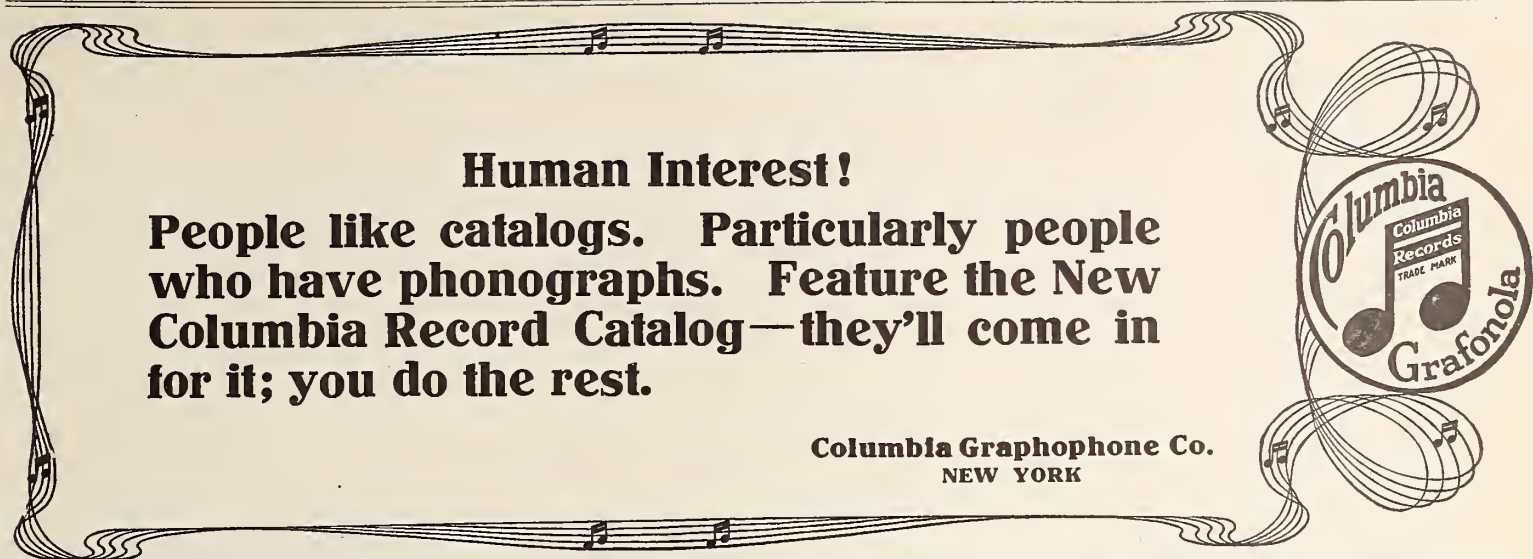

Human Interest!

People like catalogs. Particularly people who have phonographs. Feature the New Columbia Record Catalog—they'll come in for it; you do the rest.

**Columbia Graphophone Co.
NEW YORK**

TELLS SECRET OF SALE MAKING

Edison Amberola Dealer Tells How He Has Built Up a Large Business in That Line

In telling how he has built up a business in Edison Amberolas and Blue Amberol records Leslie E. Carl, an Edison dealer in Deposit, N. Y., says that the first consideration is to have on hand a good stock of machines and records and then to go after business:

"Our prospects are mostly farmers. We keep our phonograph playing in the store most of the time and you would be surprised the prospects we get in this way. When one comes in and shows the least inclination to be pleased with

sale. If they wish a lower-priced machine we can very easily supply it.

"We find this to be a very easy way to make sales with the Edison. We have sold the Edison for over twelve years and have hundreds of customers which have been made this way. If you do not have the goods in stock you cannot make sales, and you surely cannot give free trials and make sales."

TAKES OVER VICTOR DEPARTMENT

WATERLOO, IA., November 4.—The Davidson Co. have recently taken over the Victor department of the James Black Drygoods Co., this city. A complete department has been installed in the

LATEST TEL-O-TONE LITERATURE

Handsomely Printed and Interestingly Written Volume Bearing on This Chicago Musical Instrument Will Interest the Trade

A volume of more than usual interest bearing on the Tel-O-Tone phonograph, which is being placed on the market by the Western News Co., of Chicago, Ill., has just reached our desk. It contains illustrations and descriptions of the various artistic styles of Tel-O-Tone phonographs which are illustrated elsewhere in The World, as well as details of the various individual features of these instruments, notably the separator, the resonator, and the reducto. The volume contains a number of facsimile letters from prominent dealers who are handling this machine as well as from many individual purchasers. A feature of the volume is an interesting history of the phonograph.

The closing page, signed by W. Cheney Beckwith, inventor of the Tel-O-Tone sound-reproducing tone chamber, contains a succinct presentation of the claims made for this instrument as well as brief reference to the features which have made it so distinctive. Taken all in all this volume is a most interesting one, and should be productive of excellent results in informing the public regarding the Tel-O-Tone.

The war is over; now let us get busy!



Edisons in Shipping Cases in Front of Store of Leslie Carl

the clear tones of the Amberola we take him back and find out what songs or instrumental pieces he likes best; then we get him to let us put one in his home on trial; we ask him to invite to his home his friends and neighbors to hear the well-known Edison Amberola. We are very careful not to say anything about prices or terms; then we pick out about four dozen records, taking care that there will be a number in this lot which will please his particular musical taste. We always put out on trial the Edison Model 75. This gives us a cabinet for the records and makes a nice showing in his home. We use a "Tin Lizzie" for delivery and get it to his home as soon as possible, sometimes we get to his farmhouse before he gets there. We almost always find somebody at home who will let us in with the machine; we then take pains to show them how to run it, explaining the good features of the Amberola and the Blue Amberol records, how they can have any kind of music in their home simply by turning the crank. We tell them the day we are coming to get the records they do not wish to keep and leave them, letting the Amberola talk for itself.

"The day we promise to come we try to be on the job. The first thing we tell them when we arrive is that we have come to get the records they do not care to keep. Almost every time they have the rejected records all picked out and ready. Then we talk prices and terms, and there is hardly a case but what we make a

front part of the store, with four booths and a complete stock of records. L. E. Cohen is general manager of the department, and Miss Leoti Cowles, formerly of the James Black Co., has charge of the record department. Both Mr. Cohen and Miss Cowles have an enviable reputation throughout the State as "business getters," which is proven by Mr. Cohen's remark, "Our opening day was great, and we disposed of over 900 records and sold all but one of our Victrolas. The only reason that one remained was that we needed one for demonstrating records."

STANDARD CO. HEARS FROM FRANCE

The Standard Talking Machine Co., Pittsburgh, Pa., received recently an interesting letter from Sergt. D. R. Morrow, a former Standard Co. employe, now in active service in France. Sergt. Morrow told in an interesting way of the American drive against the Germans, and of the bombing of an American hospital by Boche airmen, after observations had been made to be sure of the character of their objective.

RECOVERS FROM INFLUENZA

H. B. Sixsmith, traveler for the Mickel Bros. Co., Victor wholesalers in Des Moines, Ia., was a victim of the influenza epidemic, but is now recuperating rapidly.

TONE ARMS

Immediate Deliveries

F. C. KENT & CO.

Manufacturers of Phonograph Accessories

Cor. Mulberry & Chestnut Sts.
NEWARK, N. J.

PEACE NEWS STIRS BALTIMORE

Talking Machine Dealers Forget Past Troubles in Planning for Future—Eisenbrandt & Son in New Quarters—General News of Trade

BALTIMORE, MD., November 11.—The announcement of the armistice with Germany has caused local talking machine dealers to forget their troubles of the immediate past, including stock shortage, influenza ban, etc., and begin to plan actively for the future. It might be said with truth that the trade in this territory emerged from the chaos of war in most satisfactory shape. Now everybody is wondering how they are going to take care of the rush of business expected during December. Meanwhile early buying warnings are the rule.

Despite the fact that the staff of the local Columbia branches is sadly depleted through illness, the volume of business for the month, especially in records, has shown up remarkably well. At one time fifteen members of the staff of twenty-two were absent because of illness.

Recent visitors at the store of E. F. Droop & Sons Co. were S. Ernest Philpitt, of Tampa, and Miami, Fla., and John Oachis, of the Clark & Jones Co., Birmingham, Ala., both in search of Victor goods.

The National Piano Co., Pathé distributors, are expecting some shipments of machines and records shortly to take care of the orders that are piling up.

A. Petit, local Brunswick-Balke-Collender Co. manager, is declining to place new agencies for

Brunswick phonographs until he can take care of the demands of dealers already on his books.

H. R. Eisenbrandt & Son are now in their new quarters, and they have one of the most attractive stores in the city. The show window is eighteen feet long and eight feet deep. Henry Eisenbrandt says that Victor goods will likely come along better from now on, and while he does not expect to get as many machines and records as he could handle he is hoping that the supply will be fairly ample.

LATEST CHENEY REPRESENTATIVES

Ludwig Baumann & Co., the well-known furniture house, is planning to give a special exhibition and demonstration of the complete Cheney line of phonographs, including the art models that attracted such attention at the National Music Show this summer, in the company's three stores, beginning at the Eighth avenue and Thirty-fifth street store early in December, to be followed by similar exhibitions in the Harlem and Newark stores. The exhibit

will be featured by special recitals and analytical talks. Ludwig Baumann & Co. were the first Cheney dealers in New York, and have achieved splendid success with the line.

R. W. Olsen & Co., who operate four stores in Brooklyn, have recently become Cheney dealers, and have developed a splendid demand for these instruments in their territory.

WOMEN IN THE SALES FIELD

The Edison Shop at Dallas, Tex., Tells Interestingly of How Women Are Proving Most Effective in Promoting Sales of Phonographs

The opportunity given women in industry by this war is unparalleled in the world's history. That they are taking advantage of the opportunity, or, perhaps to put it more graciously, that they are standing up to their responsibilities is becoming increasingly evident with each day's news.

The Edison Shop, of Dallas, Tex., reports most interestingly concerning the advent with them of women into the sales field of the Edison industry. They say:

"Quite a few months ago we realized that there was only one way for us to save the salesman situation and that was through the medium of ladies taking the places of our men who had gone into the service. This was some five or six months ago. To-day we now have four salesladies who are actually taking the place of our four men who have gone into service, and who are making good in every sense of the word.

"The most interesting part of it all is the fact that I have always been very skeptical over the possibilities of a woman taking the place of a man in a business way, but I assure you that now my skepticism has been entirely swept aside.

"We began by taking these young ladies through a thorough course of salesmanship through the medium of our sales meetings which we hold regularly in our shop, and each and every one of these ladies is now turning in as much or more sales even than the men whose places they took.

"There is no doubt, of course, but that our sales meetings, which we have been conducting regularly now for over a year, have had a great deal to do with the success of these young ladies, but I believe any dealer who will select carefully his young ladies and then try to tell them just what he knows about selling Edison phonographs, and keep it up consistently, will be able to get just as good results as I have. Our sales meetings have grown to be decidedly the most interesting part of our work.

"I am very enthusiastic over our salesladies and feel very gratified over the fact that even though we have lost some of our very best men, our sales have not slumped one bit, but have kept up to their 300 per cent. increase over last year right along."

CANARY RECOGNIZED GOOD MUSIC

M. J. Soukup, Victor dealer at Decorah, Ia., recently purchased a canary which would not sing. Nearly every record in the catalog was tried with no result, until he hit upon Galli-Curci's "A Little Voice I Hear," from the Barber of Seville. Instantly the bird burst forth in wonderful song, which lasted until the record was taken off. In honor of the wonderful power of Amelita Galli-Curci the bird was named "Lita."

CABINETS - - CABINETS

AND

TALKING MACHINES

FOR

Wholesalers, Dealers, Jobbers

We can supply you with high grade Talking Machines to suit your every need. While we are cabinet makers we also manufacture complete machines.

We have a large stock prepared ready for shipment to meet the requirements of the trade.

Prompt Deliveries

Inquire for Catalog and Price List of

BEN FERRARA

ONEIDA, NEW YORK

INTERESTING PROGRAM FOR DEALERS

Many Features Planned for Monthly Meeting of Columbia Wholesale Branch

The regular monthly meeting of the local wholesale branch of the Columbia Graphophone Co. will be held to-day, November 15, at the Waldorf-Astoria Hotel. Lambert Friedl, manager of this branch, who will be in charge of the meeting, has prepared an unusually interesting program that will undoubtedly result in a banner attendance.

According to present plans the artist who will appear at this meeting will be Miss Barbara Maurel, one of the latest additions to the Columbia record library. R. W. Knox, advertising manager of the Columbia Co., will give the dealers some idea of the Columbia advertising plans for the ensuing year.

The most interesting feature of this meeting, however, will be the inauguration of an open forum, which will be conducted by the dealers exclusively. It is planned to have a Columbia dealer in the chair at this forum, and undoubtedly there will be many practical subjects discussed by the dealers.

EMPIRE RECORDS FOR DECEMBER

CHICAGO, ILL., November 11.—The advance list of records for December just issued by the Empire Talking Machine Co. is as follows:

- POPULAR HITS**
- 6236 I'll Come Back to You When It's All Over (Brown-Kerry-Mills). Peerless Quartet
 - When You Come Home (Squire). Contralto with Male Trio. Una Drake
 - 6237 The Kilties March (Murchison). Empire Male Quartet
 - When the Yanks Come Marching Home (Jerome Furth). Baritone. Ben Pilgrim
 - 6238 Laddie in Khaki (Novello). Baritone, Frederick Williamson
 - What are You Going to Do to Help the Boys? (Kahn-Van Alstyne). Baritone. Arthur Fields
 - 6239 Oh, How I Hate to Get Up in the Morning (Berlin). Arthur Fields
 - When I Get Back to My American Blighty (Fields-Morse). Arthur Fields
 - 6240 Give Me the Right to Love You (Glatt). Sterling Trio
 - For the Two of Us (Leslie-Ruby). Duet, Campbell and Burr
- STANDARD VOCAL**
- 6241 The Rosary (Nevin-Rogers). Baritone. Ira Allen
 - Beautiful Isle of Somewhere (Paera). Sterling Trio
 - 6243 Silent Night, Hallowed Night (Hayden). Bijou Mixed Quartet
- INSTRUMENTAL SELECTIONS**
- 6243 Poet and Peasant Overture (Suppe). Empire Concert Orchestra
 - 6244 Poet and Peasant Overture. Part II. Empire Concert Orchestra
 - 6244 Fireflies—Intermezzo (Savino). Empire Concert Orchestra
 - Barcarolle—Tales of Hoffman (Offenbach). Empire Symphony Orchestra
 - 6245 Patriotic Medley. Part I. Empire Concert Orchestra
 - American Patriotic Medley. Part II. Empire Concert Orchestra
- HAWAIIAN SELECTIONS**
- 6246 My Lonely Lola Lo (Solman). Hawaiian Guitar accomp. Sterling Trio
 - My Hawaiian Maid (Cunha). Tenor, Hawaiian Guitar accomp. Henry Burr
 - 6247 Aloha Land (Herzer). Waltz. Hawaiian Guitars. Louise and Ferera
 - Missouri Waltz (Eppel-Logan). Hawaiian Guitars. Louise and Ferera
- COMIC SELECTIONS**
- 6249 I Sent My Wife Away for a Rest (Von Tilzer). Baritone. Louis Winsch
 - 'N' Everything (DeSylvia-Kahn-Jolson). Baritone, Louis Winsch
 - 6250 K-K-K-Katy (O'Hara). Baritone. Louis Winsch
 - That Funny Jazz Band From Dixieland (Marshall). Baritone. Arthur Collins
- DANCE SELECTIONS**
- 6251 Djer Kiss (Ager). Waltz. Empire Military Band
 - Oh, You Daddy—Fox-trot. Empire Military Band

- 6252 Nightingale Waltz (Fisher). Empire Military Band
- Liberty Loan March (Sousa). Two-step, Empire Military Band
- 6253 Cutey (Motzan). One-step. Empire Dance Orchestra
- Howdy (Sam Fox). One-step. Empire Military Band
- 6254 Popularity (Cohan). One-step. Saxophone, Banjo and Piano. Van Eps Trio
- Oriental (Rose). Saxophone and Piano, Williams and Davies
- 6255 Uncle Hiram's Husking Bee (Sweetman-Bonnell-Daly). Medley Accordion Duet. Boudini Brothers
- My Sweetie (Snyder-Louis-Young). Medley Fox-trot. Accordion Duet. Boudini Brothers

TO MAKE ONLY TWO STYLES

Operollo Phonograph Co., of Detroit, Make Announcement to This Effect

DETROIT, MICH., November 4.—An important announcement has been made from the headquarters of the Operollo Phonograph Co., 54 Lafayette West, this city, concerning their plans for future output. In accordance with the conservation methods in practice in all lines throughout the country in manufacturing plants, the Operollo Phonograph Co. will hereafter concentrate their efforts in the production and marketing of but two popular-priced models. With this concentration of effort they will be able to produce at a minimum cost a talking machine that they claim will be the very best that can be produced for the money. Plentiful stock is reported on hand at the factory, which should allow prompt delivery from the factory.

DEATH OF DR. ALVA D. JONES

Dr. Alva D. Jones, who was well known in the talking machine trade through his inventions bearing on the reproduction of sound, died at his home in Philadelphia on October 12. He was the inventor of the Perfektone sound box, and also held basic patents for the use of wickerwork for talking machine cabinets, and had taken out a great many patents covering other inventions of his relating to the industry in various countries. He was a man of great ability and highly esteemed by those who had the pleasure of his acquaintance.

EDISON FORCE TREBLES ITS QUOTA

The Thos. A. Edison, Inc., went over the top in the Fourth Liberty Loan in great shape. Their quota was \$300,000, but the final figures showed a grand total subscribed of \$1,090,300. This comprised subscriptions by the employees of \$525,000, and by the company of \$565,300. It is interesting to note that the Edison industries passed the \$2,000,000 mark for the four Liberty loans.

PUSH THE RED SEAL RECORDS!

In speaking with The World on the record situation Abram Davega, of I. Davega, Jr., Inc., Victor distributors, 125 West 125th street, New York, called attention to the fact that, although a great many numbers were exceedingly scarce, still there were quite a few Red Seal records with which the jobber was well stocked. The pushing of these numbers by the dealer with the co-operation of the jobber would add materially to the record sales and profits.

CELEBRATE PEACE AND VICTORY

Pathé Military Band and Pathé Forces, Headed by Pathé Withmann, with Kathleen Howard, Parade Fifth Avenue, Arousing Tremendous Enthusiasm

One of the interesting features of the peace day celebration on Fifth avenue Monday was an informal band concert staged by the Pathé Frères Phonograph Co.'s New York offices, 23 West Thirty-eighth street. This concert attracted much attention and contributed materially to the success of the celebration.

The concert was entirely impromptu, and was occasioned by the fact that E. A. Widmann, president of the Pathé Frères Phonograph Co., chanced to walk up Fifth avenue while the celebration was taking place. He commented upon the fact that something seemed missing in the celebration and decided that it was a lack of music which kept the funmakers from properly enjoying themselves.

Mr. Widmann lost no time, but immediately arranged for the Pathé Military Band to assemble at Thirty-eighth street and march up Fifth avenue. The band had been rehearsing at the Pathé laboratories with Miss Kathleen Howard, and within fifteen minutes had started up the avenue, accompanied by a delegation of Pathé roosters and other appropriate signs. Behind the band were the members of the office staff of the Pathé Frères Phonograph Co.'s New York office, led by O. J. Valliere, city sales manager; Wm. Penn, recording manager; Wm. H. Rose, and Mr. Weil, with Mr. Widmann as marshal.

As soon as the band commenced its march it was followed by a crowd which increased by hundreds, and by the time it reached the Public Library the band was leading a procession fully five blocks long. At the library steps Miss Howard, accompanied by the band, sang the "Star Spangled Banner" and the "Marseillaise," after which the procession continued its march up Fifth avenue, where in front of St. Patrick's Cathedral the band rendered the national anthems of the Allies. By this time the procession was fully ten blocks long and had attained such importance that moving picture operators were busy filming it for the news weeklies.

The return trip was made down Broadway, and at Thirty-eighth street the band managed to elude the ten-block procession and renew its work at the laboratories. The band concert was thoroughly enjoyed, and the importance of music was demonstrated conclusively by the fact that this band proved absolutely essential to the real success of the peace celebration.

A STEWART PUBLICATION

The Stewart Talking Machine Co., of Indianapolis, Ind., recently issued a catalog of talking machine cabinets and accessories for distribution among dealers that is unquestionably one of the most complete and exhaustive in its extent that has reached our desk for some time. The volume is admirably prepared and printed.



The STERLING "No. ONE"—A Winner

"The Phonograph of Sterling Tone and Quality"

OUR "Number 1" is a mahogany finish cabinet, size 44x20x21, listing at \$80 retail, and comparing favorably with instruments selling for considerably more. It is equipped with a universal tone-arm playing all makes of records, a tone-modifier, and the exposed parts are heavily nickel-plated. This model has a motor cast frame, goose-neck tone-arm, and a silent, double-spring worm drive motor.

Liberal trade discounts.

Compacto Phonograph Co., 31 East 12th Street, New York City

Eight Models
 —
Guaranteed in Every Detail
 —
Immediate Deliveries of Any Quantity

WORLD'S CLASSIFIED ADVERTISING

Any member of the trade may forward to this office a "Situation" advertisement intended for this Department to occupy a space of four lines, agate measure, and it will be inserted free. Replies will also be forwarded without cost. Additional space will be at the rate of 25c. per line. If bold faced type is desired the cost of same will be 25c. per line.

SALES EXECUTIVE of high caliber with a past record of things accomplished and an intimate knowledge of manufacturing and who has recently placed on the market with signal success one of the representative talking machine lines in the trade will consider new connection. My highly specialized services will be of particular value to some big live concern ambitious to become or continue real factors in the talking machine field. Address "Box 554," care The Talking Machine World, 373 Fourth Ave., New York.

SALESMAN WANTED—If you cover the phonograph trade in any section of the United States and are interested in a live proposition, either as a side line or as your main line, we have an interesting offer. In answering state territory now covered. Address "Box 522," care The Talking Machine World, 373 Fourth Ave., New York.

MANAGER—Experienced sales manager with both wholesale and retail experience and thorough knowledge of talking machine production is open for managership of enterprising, reliable, well-backed concern where he will have opportunity to grow. Salary and commission. Address "O. C., 18," care The Talking Machine World, 209 South State St., Chicago, Ill.

POSITION WANTED—By wholesale talking machine salesman to travel out of Chicago. Will take a good line on a commission basis. Address "O. C., 29," care The Talking Machine World, 209 South State St., Chicago, Ill.

WANTED—All kinds of phonographs and records, new or old, also phonograph parts. We buy anything. Address Brooklyn Phonograph Co., 675 Greene Ave., Brooklyn, N. Y.

LARGE Record Manufacturer desires services of high-class salesman for Middle West among jobbers only. An excellent opportunity to make big money. Address "O. C. 10," care The Talking Machine World, 209 South State St., Chicago, Ill.

WANTED—New and second-hand Victor and Columbia talking machines and records. Spot cash paid for them. Deninger Cycle Co., Rochester, N. Y.

WANTED—Salesmen to carry line of well-known music rolls and phonograph accessories on commission basis. Address "Box 561," care The Talking Machine World, 373 Fourth Ave., New York.

POSITION WANTED—Talking machine salesman, five years' experience, expert repairman, can take full charge, can handle both American and foreign trade. Address "Box 562," care The Talking Machine World, 373 Fourth Ave., New York.

SITUATION WANTED—I have seven years' experience in phonograph trade exclusively. Wholesale and retail. I possess executive, initiative ability. Can furnish bonded references. Will take financial interest in organization which desires services of reliable Canadian representative who would guarantee results. I am prepared to establish American instrument in Canadian market. Address "Box 564," care The Talking Machine World, 373 Fourth Ave., New York.

POSITION WANTED—Assistant manager of branch of America's largest phonograph supply factory is open for executive position. Address "Box 548," care The Talking Machine World, 373 Fourth Ave., New York.

PHONOGRAPH recorder required, thoroughly experienced and able to install and operate. Replies confidential. Address "Box 558," care The Talking Machine World, 373 Fourth Ave., New York.

POSITION WANTED—City salesman or department manager—by man of twelve years' experience. Best references. State particulars. Address "Box 549," care The Talking Machine World, 373 Fourth Ave., New York.

SITUATION WANTED—Who can use a high-class manager, either wholesale or retail, capable of taking exclusive charge and producing results? Have had over ten years' experience, willing to locate anywhere. Address "Box 540," care The Talking Machine World, 373 Fourth Ave., New York.

SITUATION WANTED—Salesman (35) acquainted with every angle of the business. Phonographs, records and sundries. Vigorous result getter on road. Drawing account against commission. Address "Phonographs," 22 East 125th St., New York.

POSITION WANTED—Talking machine salesman, five years' experience. Inside position large city preferred. Familiar with all well known machines. References. Address "A. P. 2," Talking Machine World, 209 So. State St., Chicago, Ill.

WANTED—Thoroughly experienced, aggressive Edison, Victor and Columbia manager is open to manage department. Any location. Success guaranteed. Address "J. L. 8," care The Talking Machine World, 209 South State St., Chicago, Ill.

SITUATION WANTED—Trade builder open for position November 1. My record of sales will be of interest to manufacturers who wish to further their output. Address "Box 560," care The Talking Machine World, 373 Fourth Ave., New York.

POSITION WANTED—By wholesale phonograph and piano salesman. Open for position to travel east of Chicago. Held last position 2½ years. Phonograph position preferred. Best of references. Address "Box 536," care The Talking Machine World, 373 Fourth Ave., New York.

RETAIL MANAGER OPEN—Young man, married, long experience as retail manager, open for exclusive store or department executive, talking machines or pianos or both. Middle West preferred. Address "08," Talking Machine World, 209 South State St., Chicago, Ill.

REPRESENTATIVE exceptionally well known on Pacific Coast, already carrying several representative lines, offers representation to one or two more non-conflicting lines in that territory. Will be glad to consider your proposition. Address "Box 553," care The Talking Machine World, 373 Fourth Ave., New York.

SITUATION DESIRED—Production manager and superintendent seeks position. Seventeen years' experience. Can reduce costs and increase production. Highest references. Address "S. P. 25," care The Talking Machine World, 209 South State St., Chicago, Ill.

FOR SALE

Phonograph records, lateral cut, 10 and 12 inch standard make, a fine assortment of vocal and instrumental selections. Also steel needles, finest quality, in bulk and packages.

I. DECKINGER
3064 Albany-Crescent Ave. New York

FOR SALE

All kinds of phonograph parts, such as main springs, governor springs, all kinds of gears, also 100 turn-tables 10 in., with green felt, will fit any motor, at 20c. each.

Main springs, ¾-in. size.....	15c each
Main springs, ⅝-in. size.....	18c each
Governor springs.....	25c a 100
Thumb-screws to fit all soundboxes.....	30c a 100
Green felt, 12-in.....	9c each
Green felt, 10-in.....	6c each
Micas to fit all soundboxes.....	5c each

BROOKLYN PHONOGRAPH CO.,
675 Greene Ave., Brooklyn, N. Y.

For Immediate Delivery, 5000 Main Springs

Size ⅞" by .023 by 10 ft. 6" long. \$30 per hundred, or \$28 each for the lot. Samples \$50. 16,000 winding key handles, beautifully finished in Mahogany or Ebony, \$1.10 per hundred, or \$1.00 per hundred for the lot.

EVERYBODY'S TALKING MACHINE CO.,
38 N. 8th St., Philadelphia, Pa.

GREAT LIBERTY LOAN CONCERT

Edward N. Burns, Vice-President of the Columbia Graphophone Co., Arranges Elaborate Program for Crescent Athletic Club

One of the most interesting features of the drive for the Fourth Liberty Loan was a remarkable concert given at the clubhouse of the Crescent A. C., Brooklyn, N. Y., one of the most influential and successful organizations of its kind in the country.

Edward N. Burns, vice-president of the Columbia Graphophone Co., has been a member of the Crescent A. C. for several years, and his indefatigable work in behalf of his club's Fourth Liberty Loan concert contributed materially to the success of the event. Mr. Burns was in charge of the musical program, and through his efforts the following well-known Columbia artists appeared: Madame Hulda Lashanska, Hipolito Lazaro, Miss Barbara Maurel, Arthur Fields, Harry McClasky, the Peerless Quartet and Prince's Orchestra.

The members of the Crescent A. C. subscribed

STEEL NEEDLES

AND PHONOGRAPH PARTS

Steel needles, full tone, in envelopes, per 1,000 needles.....	0.75
Sapphire needles for Edison disc, each.....	0.30
Genuine Edison diamond for disc, each.....	2.25
Main springs for Edison disc, 1¼", each.....	1.75
Main springs for Columbia disc, 1", each.....	0.65
Main springs, ⅞" oblong hole, each.....	0.30
Main springs for Columbia disc, ¾" round hole, each.....	0.35
Governor springs for Columbia motor, each 2c.; per 100.....	1.50
Governor springs for Victor motor, each 2c.; per 100.....	1.50
Governor screws for Columbia motor, each 1c.; per 100.....	0.75
Governor shafts for Bllek or Wonder motor, each.....	0.15
Governor shafts for Heilmann No. 0 or 11, each.....	0.20
Governor gear wheels, for Triton motor, each.....	0.10
Mica diaphragms, 1st for Victor soundbox, each.....	0.15
Mica diaphragms, 1st for Columbia soundbox, each.....	0.25
Mica diaphragms, 1st for all standard soundboxes, each.....	0.22
Turn-table, felt green, 10", each.....	0.20
Turn-table, felt green, 12", each.....	0.25
Motors, double springs opt. with 12" T. T., each.....	5.25
Motors, single spring opt. with 10" T. T., each.....	2.25
Tonearms, universal, with mica soundbox No. K-1, each.....	2.00
Tonearms, universal, No. H2, Sonora style, each.....	3.00
Soundbox, fit Victor tonearm, No. H-1, each.....	1.75
Soundbox, fit Standard tonearm, No. K-5, each.....	0.75
Barrels, assembled, for Bllek or Triton motors, each.....	0.60
Barrel, bottom gears, Bllek or Triton motors, each.....	0.25
Key's Slatted, Bllek or Triton, each.....	0.25
Key's Thread, for Flemish, each.....	0.25
Needle cups, fit on Columbia, per 100.....	2.50
Needle cups, with covers, for used needles, per 100.....	3.75

All orders must be accompanied with remittance.
Prices subject to change without further notice.

FAVORITE PHONOGRAPH ACCESSORY CO.
1491 DeKalb Avenue Brooklyn, N. Y.

FOR SALE

Sole Columbia agent in town suburban New York, drafted, will sell agency or stock only. Address "Box 563," care The Talking Machine World, 373 Fourth Ave., New York.

Something New

For Sale—10,000 hand lathe turned perfect steel talking machine needles, medium and light, at 7 cents each. Each needle plays 200 twelve-inch records. Guaranteed not to scratch or wear the records. W. A. Gross, 5081 Broadway, Chicago, Ill.

FOR SALE

Exclusive Columbia Graphophone Agency sixty miles from New York. Well balanced stock, finely arranged store, excellent location. Population draws over 12,000. Big opportunity and good investment for energetic man. Address M. F. C., care The Talking Machine World, 373 Fourth Ave., New York.

FOR SALE

Phonograph cabinets; four styles table models, also floor models. Can make immediate shipment in carlots. Good price to parties who can use in quantities. Empire Manufacturing Co., Rockford, Ill.

FOR SALE

Lot of 850 Meisselbach No. 66 Tone Arms and Sound Boxes in perfect condition at a bargain figure. Telephone Cortlandt 4633.
KIMBERLEY PHONOGRAPH CO., INC.
206 Broadway New York, N. Y.

for \$4,300,000 worth of bonds at this concert, and it is said the concert was the most successful single event staged during the Fourth Liberty Loan. The total subscriptions of the Crescent A. C. to the Fourth Liberty Loan were \$12,250,000.

HAVE BEEN WELL RECEIVED

The Culptone phonograph, produced by the Culp Phonograph Co., of 240 Broadway, New York City, and which had its initial announcement to the trade last month, has been favorably received throughout the trade. The four models comprising the line offer a variety of styles and prices. A. Culp, president of the company, reports that they are fortunate in having a stock on hand ready for immediate delivery and are now negotiating with agents for exclusive territory.

The Irvine Music Co., San Francisco, Cal., has added a talking machine department, which is under the personal supervision of R. S. Irvine. Handsome quarters have been arranged for.

DEATH OF LEONARD C. McCHESNEY

Advertising Manager of Thomas A. Edison, Inc., Succumbs to Heart Trouble on Monday of This Week—Prominent in Publicity Circles

The phonograph industry has just suffered a most severe loss in the death of Leonard C. McChesney, for the past sixteen years advertising manager of Thomas A. Edison, Inc., and a prominent figure in advertising circles generally. Mr. McChesney, who was fifty-nine years old, died on Monday at his home, 170 High street, Orange, N. J., of heart failure.

Mr. McChesney's interests were many. He was one of the founders of the Association of



L. C. McChesney

National Advertisers, and served as president of that organization. He was at one time president of the Orange Board of Education, and before joining the Edison interests was for twenty-one years secretary of the Orange Chronicle Publishing Co.

Mr. McChesney was recognized throughout the country as one of the foremost authorities on advertising matters generally. He, personally, was a firm believer in clean and constructive publicity and in righteous business policies. He was straightforward and direct in his dealings, frank in his opinions, and these characteristics won for him the esteem of those members

NEEDLES—We have a considerable quantity of Truetone Needles, packed 200 in a tin box, for immediate delivery. **WRITE NOW TO SECURE THESE NEEDLES** Price 75c. per thousand; special prices for large quantities.

Maestrola Mahogany Cabinet Machines, Size 15 x 15 x 7 1/2

Motor worm gear plays 2 1/2 to 3 ten inch records, one winding. Prices \$4.50 in 100 lots, in dozen lots \$5.00 each, sample machine \$5.50. Cash with order.

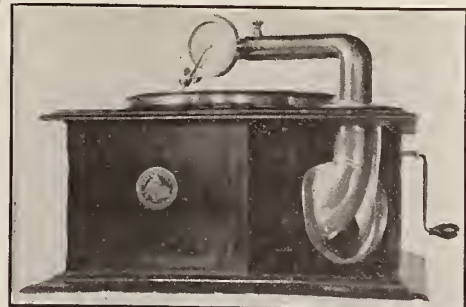

Phonograph parts selling at the old prices during November regardless of the scarcity of these supplies. Now is the time to place your order. Be wise and save money.

FULTON TALKING MACHINE COMPANY
640 Broadway New York City, N. Y.

of the trade and advertising profession who recognized their value.

Funeral services were held at the late home of the deceased on Wednesday afternoon, and were attended by the officials and many employes of Thomas A. Edison, Inc., a large delegation of advertising men, and representatives of various branches of the industry.

Mr. McChesney is survived by a widow, a son, Leonard W. McChesney, for a number of years connected with the Edison Co., and two daughters.

TALKING MACHINE RECORDS GROW

Exports, Including Records, for Eight Months Ending August 31 Totaled \$2,963,413

WASHINGTON, D. C., November 11.—In the summary of exports and imports of the commerce of the United States for the month of August, 1918 (the latest period for which it has been compiled), which has just been issued, the following figures on talking machines and records appear:

The dutiable imports of talking machines and parts during August, 1918, amounted in value to \$33,227, as compared with \$12,769 worth, which were imported during the same month of 1917. The eight months' total ending August, 1918, showed importations valued at \$249,389, as compared with \$330,840 worth of talking machines and parts imported during the same period of 1917.

Talking machines to the number of 3,796, valued at \$117,424, were exported in August, 1918, as compared with 10,059 talking machines, valued at \$218,761, sent abroad in the same period of 1917. The eight months' total showed that we exported 49,025 talking machines, valued at \$1,477,222, as against 57,222 talking machines, valued at \$1,415,398, in 1917, and 37,255 talking machines, valued at \$946,755, in 1916. The total exports of records and supplies for August, 1918, were valued at \$152,121, as compared with \$105,837, in August, 1917. For the eight months ending August, 1918, records and accessories were exported, valued at \$1,486,191, as compared with \$1,180,205, in 1917, and \$717,804, in 1916.

USOSKIN WINDOW SERVICE

November Display Meets Approval—Cardo Imitation Records in Demand—Large Canadian Demand Which Is Steadily Expanding

The November display of the Usoskin window service for Victor dealers, the second in the monthly service produced by Ed Usoskin, Inc., 230 West Seventeenth street, has met with hearty approval. The increasing number of Victor dealers using this service is noticeable. The Christmas display, which gives promises of being exceptionally fine, is almost ready.

The Cardo imitation records for window display have also met with an exceptional demand. The first issue of over 5,000 records has been entirely exhausted. The new stock was delayed in delivery to the Usoskin factory, but every attention will be given to the rapid filling of the large number of orders that have accumulated.

Ed Usoskin, Inc., have received so many inquiries for their service from Canadian dealers that an extensive campaign for that country has been approved and will be shortly under way.

H. Polliack, who handles the Columbia line in Capetown and Johannesburg, South Africa, has been spending some time in New York.

SHELTON ELECTRIC PHONOGRAPH MOTOR

We have increased our factory facilities to handle the demand for the Shelton Electric Motor, and are now ready to make prompt deliveries.

Write for our Special Agency Proposition

SHELTON ELECTRIC CO.
30 East 42nd Street, NEW YORK

NEW STRADIVARA CATALOG

Handsome Booklet Received as World Goes to Press—Seven Models Attractively Illustrated

As The World goes to press it is in receipt of a very handsome catalog published by the Compton-Price Co., of Coshocton, O., exploiting the Stradivara phonograph. The cover is of gray with a gold embossed trade-mark name "Stradivara" upon the front. The inside is printed in brown and gray, the note border characteristic of the Stradivara advertising being used on the pages. Seven models of this machine are illustrated, including the Style 250. On the back page is reproduced the extensive factory of the company, as well as the Administration Building. A more complete review of this booklet will be found in next month's World. Included in the envelope with the catalog is a very complete dealers' proposition, giving in detail the prices and discounts allowed on these machines.

RETURNS FROM COLORADO TRIP

H. A. Duncan, manager of the Victor department of the Duncan-Schell Furniture Co., Keokuk, Ia., has just returned from a health trip to Colorado Springs.

Important Notice to Dealers

Why Every Dealer Should Handle The Highest Grade Phonograph Steel Needle in the World.

The WALL-KANE

First—Each WALL-KANE needle is guaranteed to play 10 records on any Phonograph, the tenth playing as clear as the first.

Second—Phonograph owners will always purchase WALL-KANE needles, since they eliminate the troublesome changing of needles after each record.

Third—WALL-KANE needles are scientifically prepared, and, by reason of special composition, are beneficial to the grooves of the record, thereby adding to its life.

Fourth—WALL-KANE needles minimize the usual scratching sound of the ordinary steel needle and greatly improve the clearness and tone of reproduction.

TEST PROPOSED TO DEALERS TO PROVE THE SUPERIORITY OF

Wall-Kane Steel Needles

Take two standard disc records of the same selection, play one ten times with the same WALL-KANE loud needle; play the other record, the same selection, ten times, but with ten new, full-tone steel needles.

You will find that the record played ten times with the same WALL-KANE needle will sound clearer, will have less surface noise, and that under the magnifying glass the grooves of the record played ten times with the ten steel needles will seem to be more disturbed.

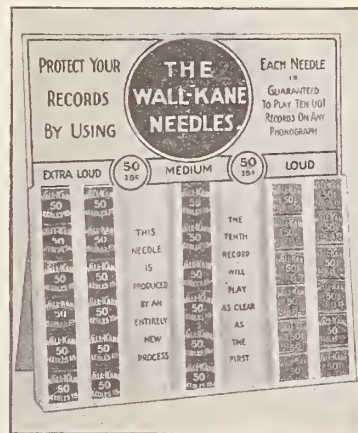

BEWARE OF IMITATIONS

Package of 50 WALL-KANE needles. Loud, Extra Loud and Medium, greater value than 500 ordinary steel needles, retails for 15c, cost the dealer 9 1/2c.

JOBBER TERRITORIES OPEN

Progressive Phonographic Supply Co.
145 West 45th Street, New York

FROM OUR EUROPEAN HEADQUARTERS

2 GRESHAM BUILDING, BASINGHALL STREET E. C., LONDON, W. LIONEL STURDY, MANAGER.

Coming of Peace Brings Speculation Regarding the Reconstruction of the Industry—Warning Against Too Much Haste—General Advance of Sixpence in Record Prices to Cover Increased Cost—Luxury Tax Bill Strongly Opposed—James E. Hough Honored by Business Associates—What Is Offered in the Latest Record Lists—New Artists Introduced—Planning Development of Overseas Trade—Feeling of Optimism Prevails—General News

LONDON, E. C., ENGLAND, November 3.—As I write, the news is to hand of President Wilson's answer to the Central Powers' request for a cessation of hostilities. Few will disagree therewith. At this stage it is difficult to foresee or estimate the likely result. Of necessity these notes from London are penned some weeks in advance of this publication. Events move so rapidly that by the time this is in print the war vista may have completely changed. In any case, the significance of the enemies' chastened mood is unmistakably fraught with large possibilities. It leads to the great hope of an earlier peace than at one time, not so long ago, the situation promised.

The news will have an immediate and far-reaching effect upon the social and commercial life of all nations. The rusty wheels of commerce will need much oil before they again revolve smoothly. But already the human hand and brain are at work in a hundred and one little ways of reorganization and commercial development. In the gramophone trade there is much to be done. As in the music industry generally, factory organizations have been converted into machinery for the propulsion of war, and it will be no light task to switch over from

this grim output to the avocation of peacetimes. It must be a gradual process occupying several weeks, and in most cases, months, of steady work before completion.

The coming of peace will not necessarily mean a great increase of business in the musical instrument and record line. During the period of demobilization and reconstruction business will doubtless be considerably disorganized even if measured by a war standard. We must not, therefore, be too sanguine of immediate results, but strive to work patiently until such time as the necessary ships of commerce are once again able to voyage over their normal trade routes of the world. This is more a time for serious preparation, a time when we should all firstly get our houses in order, so to speak, rather than rush into hasty commitments which the exigency of future conditions may nullify.

A review of the talking machine situation today would tend to show that our manufacturers are alive to the peculiar situation, and will only vigorously blossom forth when the dictates of caution are removed by a favorable outlook. Our commercial activity is at present restricted by the claims of the services. Yet, all things considered, business is in fine fettle; the nucleus of the trade has been maintained on a solid basis despite enormous difficulties, and we are ready for expansion as never before when freedom of thought and movement once again hold sway.

Henceforward, let the motto be Progress all along the line!

Record Prices Again Increased

The information given in these columns from time to time, foreshadowing an all-round in-

crease in the price of records, will have prepared the trade for the news, recently announced, of a general revision in the retail price of the leading records. One of the first to move was the "His Master's Voice" company, then the "Winner," and in turn all the other chief labels. Whether the price of the record be two, six or more shillings, it is interesting to observe that in each case the increase amounts to sixpence. The need for this additional sum is fully justified alone on the grounds of the ever-expanding cost of materials, labor, freightage, and all other production charges, which it is anticipated are likely to get worse before a change for the better can take place. Given that hostilities cease within a few months, the war is not then over. Its conclusion is for commercial purposes coincident with a return to normal conditions. Until that time arrives the effects of war remain. The position will be such as to call for war-time treatment, and no immediate slump in war prices, therefore, can be expected. It is, nevertheless, the intention of most of the record concerns to introduce a readjustment of prices as soon as may be possible, and for this purpose dealers were requested to make a return of their stocks. These statistics will be filed for future reference as and when occasion demands. This seems a very fair way of treating the difficulty, and dealers should therefore in their own interests make the required returns within the period stipulated.

By the movement to increase prices at this stage, confirmation is given to the proposal set forth in these columns that such action should anticipate the Government's forthcoming luxury tax bill. If this measure finds official acceptance along the lines of the Select Committee's



"His Master's Voice"

Copyright

This intensely human picture stands for all that is best in music

—it is the "His Master's Voice" trade-mark, and it brings to you, no matter where you are, the very best music of every kind, sung and played by the world's greatest artists—the greatest singers, pianists, violinists, orchestras and bands—all enshrined in the unequalled "His Master's Voice" records

'His Master's Voice'

—the trade-mark that is recognized throughout the world as the

HALL-MARK OF QUALITY

Branches

DENMARK: Skandinavisk Grammophon-Aktielselskab, Frihavnen, Copenhagen.

FRANCE: Cie. Française du Gramophone, 115 Boulevard Richard Lenoir, Place de la République, Paris.

SPAIN: Compañía del Gramófono, 56-58 Balmes, Barcelona.

SWEDEN: Skandinaviska Grammophon-Aktiebolaget, Drottning Gatan No. 47, Stockholm.

RUSSIA: The Gramophone Co., Ltd., 45, Nevsky Prospect, Petrograd (Petersburg); No. 1 Solyanka, Solyanov Dvor, Moscow; 9, Golovinsky Prospect, Tiflis; Nowy-Swiat 30, Warsaw; 33, Alexandrowskaya Ulitsa, Riga; 11 Michallovskaya Ulitsa, Baku.

INDIA: The Gramophone Co., Ltd., 139, Ballaghata Road, Calcutta; 7, Bell Lane, Fort, Bombay.

Great Britain :

The Gramophone Company, Ltd.

HAYES - MIDDLESEX - ENGLAND

Agencies

AUSTRALIA: S. Hoffnung & Co., Ltd., Sole Concessionaries of The Gramophone Company, Limited, 163, Pitt Street, Sydney.

NEW ZEALAND: Gramophonum, Ltd., 118-120 Victoria Street, Wellington.

SOUTH AFRICA: Darter & Sons, Post Box 174, Capetown; Mackay Bros., Post Box 251, Johannesburg; Mackay Bros. & McMahon, Post Box 419, Durban; Ivan H. Haarburger, Post Box 105, Bloemfontein; Franz Moeller, Post Box 108, East London; B. J. Ewins & Co., Post Box 80, Queens-town; Handel House, Kimberley; Laurence & Cope, Post Box 132, Buluwayo; The Argus Co., Salisbury.

EAST AFRICA: Bayley & Co., Lourenzo Marques.

HOLLAND: American Import Co., 22a, Amsterd Veerkade, The Hague.

ITALY: A. Bossi & Co., Via Orefici 2, Milan.

EGYPT (Also for the Soudan, Greece and the Ottoman Empire): K. Fr. Vogel, Post Box 414, Alexandria.

FROM OUR LONDON HEADQUARTERS—(Continued from page 108)

REX GRAMOPHONE CO.
are making a Specialty of
EXPORT
in
Horn, Hornless & Portable Disc Machines
REX GRAMOPHONE CO. 2 Elizabeth Place
Rivington Street, LONDON, E.C. 2
 Cable Address "Lyrecodisc, London" Enquiries Solicited

proposals, involving a tax of 4d. on the two shilling record, which the public will have to pay, it would obviously have been a difficult matter to increase by sixpence the rock bottom record price retail, after the Luxury Tax bill became law. As it is, the record companies have rendered their position considerably easier by their prompt action, albeit the luxury tax is thereby increased to sixpence per record. It will be seen that the standard record, which but twelve months ago sold retail at eighteenpence, has increased within that period by exactly 100 per cent., given the luxury tax becomes law. This 100 per cent. is made up by the last and the present price increase of sixpence per record each time, and the expected luxury tax levy of twopence in the shilling or any part of a shilling, making sixpence on the now minimum half-a-crown standard disc.

In the case of the "His Master's Voice" the following labels now cost retail: Plum, 10-inch double, 3/6; 12-inch double, 5/6. Black, 10-inch single, 4/; 12-inch single, 6/; 10-inch double, 5/; 12-inch double, 7/. Violet label, 10-inch single, 5/; 12-inch single, 7/. All other labels remain at the same price as heretofore.

Columbia records—Light Blue label, 10-inch double, 4/; 12-inch double, 6/. Star Light Blue, 10-inch double, 4/; 12-inch double, 6/. Purple label, 10-inch single, 5/; 12-inch single, 7/. There is no change in the price of other Columbia labels, except the Regal 10-inch double record, which is now 2/6.

The Zonophone record new prices are, 10-inch double, 2/6; 12-inch double, 4/6; Celebrity label, 3/6.

The Winner 10-inch double is now 2/6; the Scala 10-inch, 2/6; 12-inch, 3/6, and the Coliseum 10 and 12-inch the same.

The foregoing comprise the leading records, and it is expected that the smaller firms will shortly announce their intention to revise the prices of their particular makes.

The Forthcoming Luxury Tax Bill

With the reassembling of Parliament one of the first measures to come under consideration is the question of so-called luxury taxation. The findings of the Select Committee will need much revision before they can come before the House with any chance of acceptance. One typical example may be cited. A £5 gramophone or a 2/ record is to be taxed to its utmost limit, while according to the official report the tax on pianos only commences from the

price of £40 and onwards. Why this differentiation? Any ordinary person would vote rather for a heavier taxation, if anything, on the purchaser of a musical instrument up to £40 than upon the poor man who can perhaps only afford musical entertainment to the extent of a few pounds. It is against such glaring absurdities that the new Gramophone Association and its members take keen exception. Energetic action to secure a cancellation of the whole proposal as applied to all musical instruments has been put into effect by the issue to the trade of explanatory literature, which includes a draft petition to the Prime Minister, to which the signatures of the musical public are invited.

Presentation to James E. Hough

An interesting day in the annals of the gramophone trade was that of October 17, when a presentation and luncheon was given at Frascati's Restaurant, this city, to "Jimmy" Hough, popularly recognized as "The Father of the Trade," in honor of his seventieth birthday. In all there were present 105 members of the trade representative of manufacturers, factors, dealers, music publishers and artists, not to mention the "one in a hundred," Mrs. Hough, whose presence lent added charm to the proceedings. Sir George Croydon Marks, M.P., O.B.E., took the chair, with M. E. Ricketts (Gramophone Co.) as vice-chairman. After an excellent war-time luncheon the chairman in a happy speech made interesting reference to his old-time associations with Mr. Hough, to whose business acumen and straightforwardness the whole trade was much indebted for the progressive development of the phonograph industry. The feelings of the audience were truly reflected when Sir George stated that Mr. Hough, while always following a path of his own cutting, had always displayed a straight and honest endeavor in his dealings with others; a man whom all held in the highest esteem and respect. For so long Mr. Edison's attorney in this country, Sir George spoke with authority in his brief historical reference to the early talking machine days.

After reference to the wonderful value of music to-day, the chairman presented to Mr. Hough, amid loud applause, a set of handsome silver bowls as representing a mark of the great esteem in which he was held by his trade friends. A beautiful bouquet was next presented to Mrs. Hough in a few felicitous words by Sir George.

The rising of Mr. Hough to reply evoked a storm of cheers from an audience which had expectantly awaited this opportunity to again express the pleasure which all felt at meeting their old friend under such happy circumstances. When silence was restored it was seen that Mr. Hough felt very keenly the splendid reception offered to him, and after giving oral expression thereto in suitable words of appreciation and thanks he proceeded to delight an attentive audience by a most interesting, not to say in-

Soundboxes

If you are after a genuine offer of soundboxes, you'll do well to communicate with us immediately. We have tens of thousands of perfect soundboxes, fitted with the best quality mica. Confidently recommended for cheaper machines, absolutely reliable and give excellent reproduction. Price to clear \$50 per gross, F. O. B. London.

Orders for less than gross lots not accepted

Wire "Knotaslepe, London".

W. H. Reynolds (1915) Ltd.
 45, City Road, London, E. C.

Write for new illustrated Complete Catalogue

structive survey of the talking machine field during the past thirty years.

Reference should also be made to the fact that Mr. Hough was the recipient of a very fine clasp album from the employes of J. E. Hough, Ltd., as a personal mark of their high esteem and respect for "the Guvnor."

The Latest Zonophone Program

Notwithstanding war conditions the British Zonophone Co. has throughout continued the maintenance of the excellent standard of quality for which Zonophone records were renowned in pre-war days, as now. This is more than confirmed by their latest issues, and by the enormous sales of these records. Records of the "Soldier Boy," "Going Up," the "Lilac Domino," and other London successes, as played by the Black Diamond Band are typical of Zonophone instrumental recording, and good examples of vocal contributions are furnished by the latest records of Sydney Coltham, George Parker, Herbert Payne, Peter Dawson, Zono Vevey, etc. The Misses Elsie and Dorothy Southgate on the violin and minstrel organ are responsible for a magnificent rendition of Eileen Alannah, and Killarney.

The records mentioned, as indeed all on this list, promise big sales for live home and overseas dealers.

"His Master's Voice" Special Operatic Issues

The operatic triumphs of "His Master's Voice" are in very truth sans finale. One complete series after another has been issued, or is in prospect. The wide popularization of operatic music owes much to the gramophone, which, if for no other musical attribute, is thereby elevated as high into the realms of art as can be

(Continued on page 110)

GUARDSMAN RECORDS

REGISTERED



TRADE MARK

10 inch and 12 inch Lateral Cut

We can ship you immediately, any quantity of Records:

BANDS ORCHESTRAS INSTRUMENTAL SOLOS VOCAL

WIDE SELECTION OF CLASSICAL AND POPULAR TITLES

The Latest American and British works are promptly recorded by the best artists of the day.

Get a trial lot at once (your regular orders will follow) and secure yourself for the coming season's trade.

Apply for Lists and Prices to **INVICTA RECORD COMPANY, Ltd.**

Cables: Duarrab, London

1 New Inn Yard, London, E. C., England

FROM OUR LONDON HEADQUARTERS—(Continued from page 109)

attained through any channel of effort. The educational value of records is no more in doubt than is their artistic purity and fidelity of expression. The complete issue of "The Mikado" has now been followed by the publication on "His Master's Voice" records (eleven twelve-inch double discs) of the whole of Edward German's famous "Merrie England," covering all the vocal and instrumental numbers. Additional interest is lent thereto by the fact that the performance was throughout recorded under the personal superintendence of the composer. A wonderful achievement truly, and of which the Gramophone Co. may well feel, as they do, justly proud.

A promising operatic artiste who has recently made her record debut on "His Master's Voice" discs is Miss Olga Haley. In a comparatively short time she has captivated the British musical public, having appeared on the chief provincial concert platforms, as well as at the Queen's and the Albert Halls, this city. The Gramophone Co. has secured Miss Haley's valuable voice under a long and exclusive contract.

Winner Co. Introduce New Artists

As announced elsewhere the Winner record price is now two shillings and sixpence. Accompanying this advice to the trade particulars were given of some fine new record issues, special attention being drawn to the contributions of three eminent artistes whose services are now exclusive to Winner. The names in question are Chas. Tree, the well-known baritone; Herbert Cave, a tenor of operatic renown, and George Bass, the versatile North of England comedian. These gentlemen enjoy a big reputation among the record public, and their exclusive acquisition by the Winner people is regarded as a scoop of the first importance.

Steady Demand for Guardsman Records

The Invicta Record Co. report a continuous gratifying demand for their series of "Guardsman" records, the main difficulty being to insure a sufficient supply to meet the increasing sales reported by their dealers. It has come very near the rationing stage at times, but fortunately definite action in this respect has been avoided. The company's musical director has been paying special attention of late to the issue of twelve-inch classics, which have met with a favorable reception. In this regard I learn that new recordings will shortly be announced, and that something good is on the tapis. A fine sales opportunity for oversea dealers!

Miscellaneous News Items

In Arras recently, Phillip Gibbs, the war correspondent, mistook a "Decca" gramophone rendition as the living voice of a woman. A pardonable mistake; still more, a splendid tribute to the fidelity of this wonderful instrument! The incident has formed the subject of a special announcement by Barnett Samuel & Sons, Ltd., the makers.

The death in action is announced of Corp. Albert Harding, a valued servant of "His Mas-

ter's Voice" company. Up to the capture of Jerusalem, where he was wounded, he fought through the Palestine campaign as a member of the London Scottish. After recovery he was transferred to the French front, where he followed so many of his splendid comrades into the Great Unknown.

A considerable number of records will be withdrawn from "His Master's Voice" November catalog. Dealers have been advised to push the sales of any of these which may be on hand.

A perfect model of "Nipper," the famous H. M. V. dog, is now purchasable from the Gramophone Co.; only a limited number are available.

The Winner Record Exchange scheme, whereby old discs may be replaced by new, is still running.

Needles are to be imported from Japan, subject to a license, the tonnage to be taken from the American concession.

No Increase Here

In connection with the increased prices announced elsewhere in this issue, it should be noted that there is no change in the following Columbia series: Dark Blue label, 10-inch, 3/; 12-inch, 5/. Brown label (Italian Opera), 10-inch, 3/6d; 12-inch, 5/6d. Red label (Grand Opera), 10-inch, 5/6d; 12-inch, 8/. Pink label, 10-inch, 8/; 12-inch, 12/6d.

New Zealand Trade Commissioner in London

R. W. Dalton, H. M. Trade Commissioner in New Zealand, is now on a visit to London. He will consult with British firms regarding the trade possibilities of the New Zealand market. Letters for appointment should be addressed to Mr. Dalton, care of the Board of Trade Intelligence Branch, Basinghall street, E. C.

About Tenors in General and One in Particular

There are many tenors making records to-day, and each is noted for some characteristic quality of voice, and has his own particular circle of admirers. There is the dramatic tenor who claims attention for his declamation and forceful rendition of the heavier passages of opera. And there is the lyric tenor who, in various ways, seeks to impress the lighter songs with his own individuality. Among the methods of the lyric tenors there is one that has invariably met with conspicuous success. Not a few people consider the hallmark of a tenor to be the power with which he can sustain his top notes, and the greater the burst the more enjoyment this section of the public seem to derive from the singing. Where a song calls for it it is art, but there are many ballads of repose and sentiment in which it is markedly out of place. The larger public, of course, recognizes this, and there is consequently a wide appreciation for the methods of a tenor who realizes that true art lies in the natural expression of the beauties of song—who, while capable of voicing a top note of irreproachable purity can yet utter it at its right value in relation to the song, instead of employing it as a vehicle in which to

show off an excess of lung power. Add to that a vocal organ that permits of the production of music and you have the ideal tenor.

Such a tenor, for example, is Eric Randolph. His "Regal" record of "In an Old-Fashioned Town" is a notable example of his artistic work—his delightful mezzo-voce finish being a veritable touch of triumph. But all his records are characterized in this way, and, although there is not a large repertoire available, what is lacking in quantity is made up in quality.

The Fascination of Folk Song

In the latest "His Master's Voice" supplementary list of records are given two programs (1) Instrumental works founded on folk songs, (2) Vocal music selected from folk songs. The lists are almost international in character and comprise a number of items that one particularly associates with the Victorian era, version though, for that matter, none the less popular to-day, as witness: "D'ye Ken John Peel," "Banks of Allan Waters," "The Lowland Sea," "Volga Boatmen's Song," etc.

Coincidentally with the issue of these records, Henry Coates writes:

"Every country has its store of those sweet songs—centuries old—which have been handed down from generation to generation through the ages, and which we moderns know as folk songs. Their origin no one can with certainty tell. Like Topsy, they 'just grewed.' Their earliest beginnings must have been with our primitive forefathers, who would tell a simple tale in prose or rudimentary poetry, accompanying it with some sort of chant or simple vocal inflections. The idea would be handed on, improved and altered, preserved only by the bards themselves, for these folk songs must have begun before ever music had a written notation, until at length some sort of actual melody was arrived at. That melody in turn would gradually change its shape, for modern researches into folk song have brought to light many different versions of the same song existing in different parts of the same country, modified in each case, of course, by local conditions. To the strenuous and complex life of to-day the sweet savor and simplicity of folk song comes like a cool draught to parched lips. Much of the modern musical art has been founded upon it, for our musical master minds have realized the significance and beauty of these melodies which have been forged by the ages out of the people themselves, and not created by any artificial process. One need only recall, for example, the wonderful 'national' school of Russian music to show what great musicians can do with this material. Those wonderful operas and symphonies which have delighted us in these past few years have all been built from this material. In our own country native composers have begun to do the same thing, and many a fine orchestral work has been written in the same way. England, Scotland, Wales and Ireland are all rich in folk tunes of the most exquisite description, many of them amongst the finest examples of traditional music."

EDISON BELL**WINNER**
TRADE MARK
GRAMOPHONE RECORDSCABLE
"PHONOKINO,
LONDON"**ARE THE GREATEST VALUE FOR MONEY PRODUCED IN GREAT BRITAIN**

TEN INCH

DOUBLE SIDED

NEEDLE CUT

PLAY ON ALL GRAMOPHONES**Catalogue contains 4000 Titles by the Premier Artistes, Instrumentalists, Orchestras and Bands of the British Empire**

DEALERS PREPARED TO DO BUSINESS ARE INVITED TO COMMUNICATE WITH

Proprietors and Manufacturers, J. E. HOUGH, Ltd., 62 Glengall Road, London, S. E. 15, England

LATEST PATENTS RELATING TO TALKING MACHINES AND RECORDS

WASHINGTON, D. C., November 8.—NEEDLE HOLDER FOR SOUND BOXES.—Emil Albert Dodelin, Moorestown, N. J. Patent No. 1,276,192.

This invention relates to talking machines, and has particular reference to the sound boxes thereof.

The object of the invention is to provide an improved and simplified device for use in conjunction with the sound box of a talking machine, whereby a needle will be automatically clutched when the sound box is in an active position, and similarly released when said sound box is in an inactive position.

Another object resides in providing means for facilitating the operation of associating a needle with the stylus of a talking machine, reproducer or sound box, in order that the process will be simplified and expedited, this being accomplished by eliminating the service of set screws hitherto employed in this capacity, and by using in place of said screws automatically operating mechanism which will efficiently perform the same function as the set screws, and will eliminate to a large extent the element of manual labor hitherto necessary to effect the positioning of said needles.

Further objects reside in a device of the above character which may be formed with or conveniently attached to a talking machine, and in one which will be reliable and efficient in operation, not likely to become out of order.

Figure 1 is a side elevation of a talking machine, illustrating the application of the present invention to the sound box thereof, the latter being shown in an inactive position. Fig. 2 is a similar view, on a large scale, disclosing

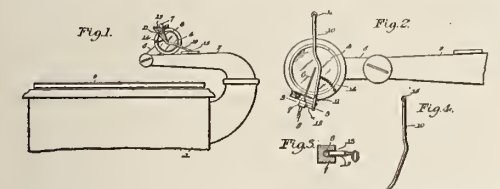

the sound box in its active or playing position. Fig. 3 is a transverse sectional view taken along the line 3—3 of Fig. 2, and Fig. 4 is a detail perspective view of the controlling lever.

TONE ARM FOR TALKING MACHINES.—Frank Malocsay, New York, assignor to the Sonora Phonograph Corp., same place. Patent No. 1,276,551.

This invention relates to a tone arm for talking machines of the disc record type, and has for its object to produce a tone arm which is simple and cheap, and one which may be moved to the position wherein the stylus will engage with the record groove and be locked in such position.

A further object is to produce a tone arm which may be swung to one side of and above the record surface and be locked in such position.

A further object is to so proportion the parts that the tone arm cannot be removed from its position relatively to the rest of the apparatus until it shall have been swung horizontally to a predetermined position.

According to the following drawings Figure 1 is a top plan view of a portion of the talking machine embodying the invention; Fig. 2 is a

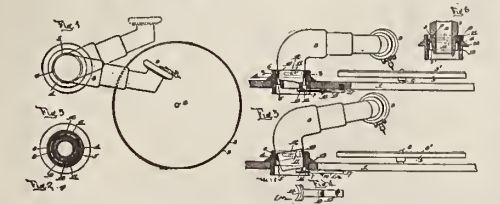

side elevation of the same partly in section; Fig. 3 is a similar view with the tone arm in another position; Fig. 4 is a detail plan view of locking spring; Fig. 5 is a section on the line 5—5 of

Fig. 2; and Fig. 6 is a detail sectional view of a modified form of bearing for the tone arm.

DUPLEX GRAPHOPHONE.—Frank C. Hinckley and John Graham, Bridgeport, Conn., assignors to American Graphophone Co., same place. Patent No. 1,276,759.

This invention relates to talking machines, and more particularly to machines of this type employing a plurality of sound boxes having styli which simultaneously and consecutively track the same record groove.

Stated broadly, the invention comprises, in combination with a record support, a plurality of sound boxes each provided with a stylus, means, preferably independent tone arms, mounting said sound boxes in co-operative relation with a record on said support, to enable said styli to simultaneously and consecutively track the record groove, and means to position said styli in consecutive portions of the record groove at any desired point in the length thereof. One of said sound boxes is preferably mounted for movement with respect to its mounting means to enable its stylus to be moved in a plane extending longitudinally thereof into alinement with the stylus of the other sound box, such movement preferably bringing the points of said styli into substantial coincidence. To secure such proper alinement of the styli, one of said sound boxes is preferably provided with cam means coacting with means upon the other of said sound boxes for guiding said styli into their proper relationship. Furthermore, the sound boxes are preferably mounted for independent movement about a common axis to permit their traverse of the record tablet, and about a common axis to permit their movement in planes at angles to said record tablet. Additionally, when tone arms are employed for mounting said sound boxes, said tone arms are preferably connected with separate sound amplifying means by elbows swivelly connected with the tone arms and having rotatable and slidable connection with said amplifying means.

Figure 1 is a plan view of a talking machine embodying the present invention, parts being shown in section; Fig. 2 is a side elevation of the machine shown in Fig. 1, parts being shown in section; Fig. 3 is an end elevation of the plurality of sound boxes on an enlarged scale; Fig. 4 is a side elevation of the styli and stylus

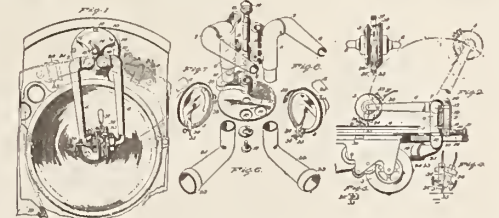

carriers when the former are moved into engagement, being on a further enlarged scale; Fig. 5 is a section on the line 5—5 of Fig. 4; Fig. 6 is a perspective view of the mounting for the tone arms and of the connections between said arms and the sound amplifying means, with the parts shown in detached relationship; and Figs. 7 and 8 are perspective views of the respective sound boxes.

RECORD FOR PHONOGRAPHIC MACHINES.—August C. Rutzen, Cleveland, O. Patent No. 1,276,968.

This invention pertains to records for phonographic machines, and the invention consists in a strip of flexible material of the nature of a ribbon or piece of tape having sound reproducing channels or grooves formed therein and substituted for the cylinders or discs heretofore commonly used for this purpose.

In the accompanying drawings Figure 1 is a plan view of a reproducing mechanism and a record embodying the invention, and Fig. 2 is a sectional elevation of said mechanism, lengthwise and showing a record mounted on a pair of rolls and a bearing roll between the same over

or upon which the reproducing needle operates. Fig. 3 is a plan view corresponding substantially to Fig. 1 except that the reproducing mechanism is omitted and the middle portion of the record strip is broken out, bringing the

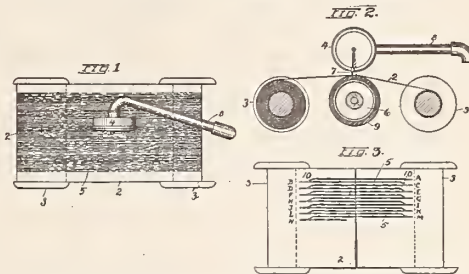

two ends near together and showing the sound lines or channels enlarged.

CONTROLLING MECHANISM FOR PHONOGRAPHS.—Harry M. Smith, Chicago, Ill. Patent No. 1,276,983.

This invention relates to improvements in phonographs and particularly to the provision of means for manually controlling the character of the vibrations received from the record.

In a machine of this character, it is desirable to provide means for enabling an individual to control the sound produced from the record, as in this way one is enabled to impart individual expression to the music produced. Heretofore means have been devised with this aim in view, which means have consisted in varying the size of the air passage, and thus checking, to a greater or less extent, the sound produced.

By this invention, however, instead of thus choking the sound, the vibrations of the diaphragm are controlled, as is also the amount of the sound produced.

A special feature of this invention is the provision of pneumatic means for controlling the sound, as through such an arrangement very efficient results are obtained, and the construc-

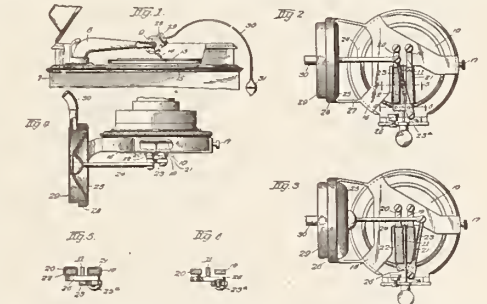

tion is one that is simple and easily applied to a phonograph.

A further feature of the invention is in having the device so arranged that it can be readily attached to practically any form of phonograph.

Figure 1 is a side elevation, partly in section, of a phonograph provided with the improved attachment. Fig. 2 is an enlarged detail view of the improved controlling mechanism, showing the parts in their normal position, with the bellows collapsed and the vibrating arm free to vibrate. Fig. 3 is an enlarged detail view similar to Fig. 2, showing the parts in the position they assume when the bellows are expanded and the vibrations of the vibrating arm dampened. Fig. 4 is a plan view, partly in section, of the sound box with the improved attachment. Fig. 5 is a sectional view taken on the line 5—5 of Fig. 2. Fig. 6 is a sectional view taken on the line 6—6 of Fig. 2.

SOUND REPRODUCING MACHINE.—Hugh J. McGreal, Milwaukee, Wis., assignor of one-half to Michael S. Sheridan, same place. Patent No. 1,277,096.

It is one of the objects of the present invention to provide a sound reproducing machine having a life-size head mounted on the upper portion of the machine and having a horn extending from the reproducer to the head to give the impression that the reproduced sound is coming directly from the head.

A further object of the invention is to provide a sound reproducing machine having a divided amplifying horn, one branch of which extends to a head mounted on the upper portion

(Continued on page 112)

LATEST PATENTS RELATING TO TALKING MACHINES AND RECORDS—(Continued from page 111)

of the machine and the other branch extends downwardly through the machine in the ordinary manner.

A further object of the invention is to provide a sound reproducing machine having a divided or branched amplifying horn, and through either or both branches of which the sound may be directed.

A further object of the invention is to provide a sound reproducing machine which is of simple construction, is strong and durable and is well adapted for the purpose described.

Figure 1 is a vertical sectional view of the improved sound reproducing machine; Fig. 2 is a horizontal sectional view thereof taken on line

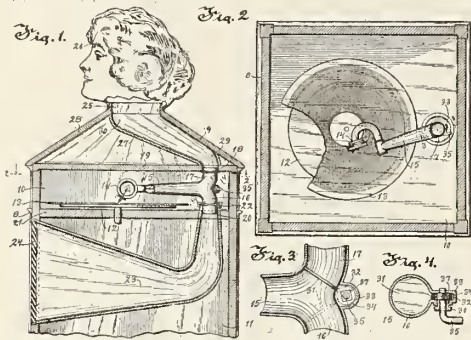

2-2 of Fig. 1; Fig. 3 is a sectional detail view taken on line 3-3 of Fig. 2; and Fig. 4 is a transverse sectional view taken on line 4-4 of Fig. 1.

SYNCHRONOUSLY OPERATED REPRODUCING APPARATUS.—Lawrence Langner, London, Eng., assignor to the Aeolian Co., New York. Patent No. 1,277,224.

This invention relates to means for securing and maintaining synchronism in the operation of two or more reproducing machines, such as a talking machine and a player-piano.

Figure 1 shows the invention applied to an electrically-operated player-piano and disc talking machine. Fig. 2 shows portions of the talk-

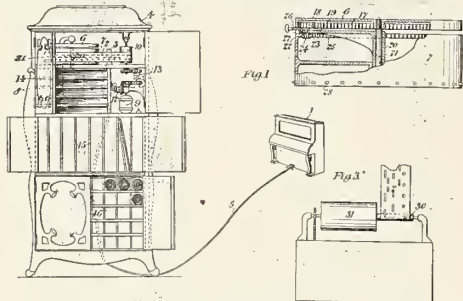

ing machine and associated parts to a larger scale, and Fig. 3 illustrates one form of the invention applied to a cylinder record talking machine.

SOUND REPRODUCING MACHINE.—Louis P. Jackson, Schenectady, N. Y. Patent No. 1,277,594.

This invention relates to improvements in sound reproducing machines and has for its object the provision of improved means whereby in a machine of this character the distinctness with which the sound is reproduced is increased. This application is a division of an earlier application, Serial No. 707,889, filed July 5, 1912, and which issued as Patent No. 1,232,924, and has certain features in common with a later application filed May 12, 1917, Serial No. 168,167.

One of the objects of the invention is to provide improved sound reproducing means where-

by the sound is reproduced in its original tones without the presence of disagreeable noises. In one aspect the invention comprises improvements in the reproducer consisting mainly in the provision of a diaphragm and other mem-

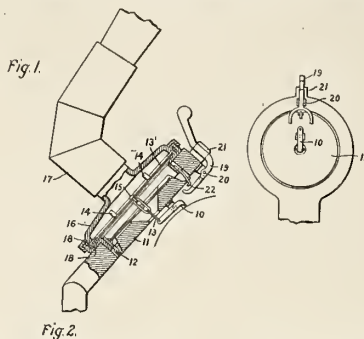

bers of lignum vitae or similar material. Cushion members of chamois skin or the like are likewise provided, together with stops for reducing or modifying the vibrations of the diaphragm.

In the accompanying drawing illustrating this invention, Figure 1 is a side view mostly in section of the improved reproducer; and Fig. 2 is a bottom plan view of the same.

TALKING MACHINE.—Joseph H. Dickinson, Cranford, N. J., assignor to the Aeolian Co. Patent No. 1,279,522.

This present invention relates to the hereinafter shown or described improvements in talking machines, phonographs and the like.

In the drawings, which show only some of the specific embodiments that these improvements are adapted to take, Figure 1 is a front

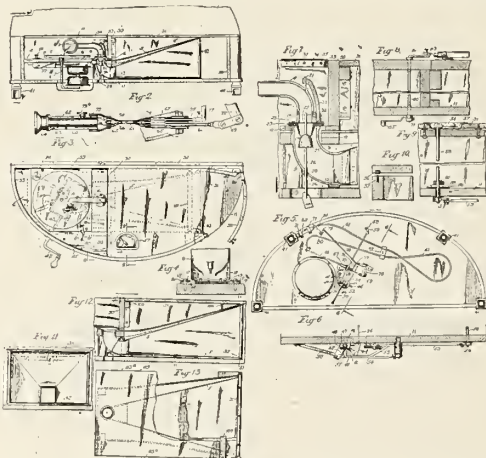

view of the instrument having the front wall of the casing removed to show the contained parts, and showing the lid elevated with its upper portion broken away; Fig. 2 is a longitudinal sectional view, on a relatively enlarged scale, of the handle and flexible control devices for operating the dynamics control valve and the brake; Fig. 3 is a top plan view of the instrument with the lid raised and with a portion of the permanent top 31 of the right-hand portion of the instrument broken away to reveal the underneath structure; Fig. 4 is an enlarged detail showing how the small neck end of the horn is supported in insulated manner on the bottom board of the instrument; Fig. 5 is an underneath plan view of the instrument; Fig. 6 is an enlarged sectional view on the line 6-6 in Fig. 5 looking in the direction of the arrows; Fig. 7 is an enlargement of the middle portion of Fig. 1; Fig. 8 is an enlarged detail of the brake means looked at from the front of the instrument; Fig. 9 is an enlarged detail of the dial pointer means for setting the dynamics control valve so that the instrument will play with a degree of loudness indicated by the pointer, the view being a sectional view

on the line 9-9 Fig. 3 looking in the direction of the arrows; Fig. 10 is an enlarged detail showing a modification of the means provided for making a sound-tight joint between the lid and the body of the casing of the instrument; Fig. 11 is a view of the horn and casing of the instrument looked at from the right-hand end of Fig. 12; Fig. 12 is a longitudinal section through the same parts shown in Fig. 11; Fig. 13 is a top plan view of the same parts showing horn broken away to reveal the underlying structure.

SUPPORT FOR THE SOUND BOXES OF TALKING MACHINES.—Horace Sheble and Thomas Kraemer, Philadelphia, Pa., assignors to the Domestic Talking Machine Corp., same place. Patent No. 1,280,565.

The object of this invention is to provide simple and effective means whereby the sound box of a phonograph instrument can be so mounted upon the tone arm as to be readily changed from position for use in connection with records of the "lateral wave" type to po-

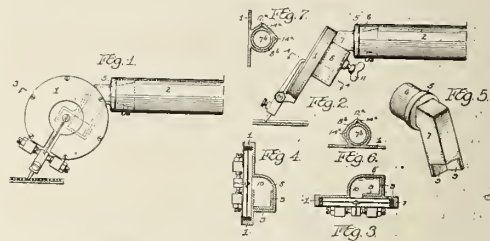

sition for use in connection with records of the vertical cut or "hill-and-valley" type, the sound box when in either position being so locked to the tone arm as to prevent displacement of the sound box from its proper relation to the record.

Figure 1 is a side elevation of the sound box of a phonograph and part of the tone arm employed in connection therewith, illustrating the invention and showing the parts in position for use in connection with a record of the lateral wave type; Fig. 2 is a side elevation showing the sound box and tone arm in position for use in connection with a record of the vertical cut or hill-and-valley type; Fig. 3 is a transverse section on the line 3-3, Fig. 1; Fig. 4 is a transverse section on the line 4-4, Fig. 2; Fig. 5 is a perspective view of that member of the tone arm which engages with the sound box member; and Figs. 6 and 7 are horizontal sectional views in different positions of sound box and tone arm members illustrating a modification of the invention.

The Montgomery Fair, Montgomery, Ala., has installed a talking machine department.

SCHUBERT Double Disc RECORDS. A \$30 Record Investment Starts YOU with complete, up-to-date list of Popular Vocal and Instrumental Selections. 10-INCH DOUBLE DISC. 20 to 30 New Selections Monthly. We guarantee you against loss of Record Investment. Liberal Discounts. Send for Details. BELL TALKING MACHINE CORPORATION (Record Department) 44 WEST 37th STREET, NEW YORK, N. Y.

MAKE YOUR SHOW WINDOWS PAY YOUR RENT. Record Display Stands, Hold any Size Record. Golden Oak or Mahogany Finish—5 Sizes. No. 341, 1 Record \$1.00 ea. No. 312, 2 Records \$1.25 ea. No. 313, 3 Records \$1.50 ea. No. 311, 4 Records \$1.75 ea. No. 315, 5 Records \$2.00 ea. THE OSCAR ONKEN CO. No. 6651 4th St., Cincinnati, O.

NEEDLES WE MANUFACTURE. Diamond needles for Edison. Sapphire needles for Edison. Sapphire needles for Pathe. in stock ready for delivery. MERMOD & CO., 505 5th Ave., N. Y.

REPAIRS. All Makes of Talking Machines Repaired Promptly and Efficiently. TALKING MACHINE REPAIR AND SALES CORPORATION. ANDREW H. DODIN, President. 176 Sixth Avenue New York. TELEPHONE, CHELSEA 8437.

RECORD BULLETINS FOR DECEMBER, 1918

COLUMBIA GRAPHOPHONE CO.

- A2646 Memories of Christmas, Part 1. "The Village Church." (Compiled and composed by Robert Hood Bowers.) With contralto and male quartet. Descriptive. Prince's Orchestra Memories of Christmas, Part 2. "The Tree at Grandmother's." (Compiled and composed by Robert Hood Bowers.) With contralto solo and male quartet. Descriptive. Prince's Orchestra
49354 "La Traviata"—Parigi o Cara (Far from the Parisian Throng (Verdi). Soprano and tenor duet, orch. accomp., Maria Barrientos and Hipolito Lazaro
A2628 Song of the Chimes (Worrell). Cradle song. Mezzo soprano solo, orch. accomp., Barbara Maurel
The Slumber Boat (Gaynor). Mezzo soprano solo, orch. accomp., Barbara Maurel
77085 Ballo in Maschera. Alla Vita Che T'Arride (The Life Thou Dost Cherish). Act I. Baritone solo, orch. accomp., Riccardo Stracciari
A2644 Christmas Chimes (Vandersloot). Reverie. (Chimes by Howard Kopp). Prince's Orchestra Cathedral Chimes (Arnold and Brown). (Chimes by Howard Kopp). Prince's Orchestra
A2632 Mariana—Scenes That Are Brightest. (Theme with variations.) Adapted by Maurice F. Smith. Clarinet solo, orch. accomp., Thomas Hughes
Song, Long Ago (Ritter). Clarinet solo, orch. accomp., Thomas Hughes
A6076 Carmen—Selections. (a) Prelude; (b) Les Toreadors (Bizet). Under the direction of Artur Bodanzky. Metropolitan Opera House Orchestra
A6074 In the Sweet Bye and Bye (Webster). Orch. accomp., Columbia Mixed Quartet
A2638 My Baby Boy (Von Tilzer). Tenor, orch. accomp., Lewis James
You're the Greatest Little Mother in the World (Gottler). Male voices, orch. accomp., Peerless Quartet
A2640 In 1960 You'll Find Dixie Looking Just the Same (Gottler). Male voices, orch. accomp., Sterling Trio
Caroline, I'm Coming Back to You (McHugh). Male voices, orch. accomp., Peerless Quartet
A2636 You Keep Sending 'Em Over and We'll Keep Knocking 'Em Down (Ruby). Baritone, orch. accomp., Arthur Fields
When I Get Back to My American Blighty (Morse). Tenor, orch. accomp., Irving Kaufman
A2635 For Your Boy and My Boy (Van Alstyne). Male voices, orch. accomp., Peerless Quartet
Uncle Sammy (Hulzmann). Baritone solo, band accomp., Arthur Fields
A2637 Oui, Oui, Marie (Wee, Wee, Marie) (Fisher). Tenor solo, orch. accomp., Irving Kaufman
My Wild Days Are Over (Brown). Tenor solo, orch. accomp., Irving Kaufman
A2643 Where Have You Been Hiding All These Years? (Kraus). Tenor solo, orch. accomp., Henry Burr
Give Me All of You (from "Flora Bella") (Schwarzwald). Tenor solo, orch. accomp., Hugh Donovan
A2630 They Were All Out of Step But Jim (Did You See My Little Jimmy Marching?) (Berlin). Character duet, orch. accomp., Van and Schenck
Ragtime Moses' Old-time Bomboshay (Franklin). Baritone and tenor duet, orch. accomp., Van and Schenck
A2629 Beans, Beans, Beans (Smith). Comedy, orchestra accomp., Gus Van
I'm Too Tired to Make Love (Creamer and Layton). Character song, orch. accomp., Gus Van
A2641 They'll Be Mighty Proud in Dixie of Their Old Black Joe (Carroll). Tenor duet, orch. accomp., Campbell and Burr
If I'm Not at the Roll Call (Kiss Mother Good-bye for Me) (Boyden). Tenor duet, orch. accomp., Campbell and Burr
A2642 While You're Away (Pack Up Your Cares in a Bundle of Joy) (Gilbert and Friedland). Tenor and quartet of male voices, orch. accomp., Henry Burr and Peerless Quartet
I Love You More for Losing You a While (Whiting). Tenor solo, orch. accomp., Hugh Donovan
DANCE RECORDS
A2634 Tishimingo Blues (Williams). Medley Fox-trot. Intro. "Some Chocolate Drops" (Irvin and Vodrey). American Marimbaphone Band
Hear Dem Bells (Old-time Songs). Medley One-step. Intro. (1) "Hot Time in the Old Town To-night," (2) "Auld Lang Syne," (3) "Reuben and Cynthia," (4) Listen to the Mocking Bird," (5) "Johnny Get Your Gun."
A2645 Those Draftin' Blues (Pinkard). Medley One-step. Intro. (1) "Somebody's Done Me Wrong" (Skidmore and Friedlander). Sweetman's Jazz Band
Rock-a-Bye Your Baby With a Dixie Melody (from "Sinbad") (Schwartz). Fox-trot, Sweetman's Jazz Band
A2639 Hindustan (Wallace and Weeks). Fox-trot. Violin and piano duet. Jockers Brothers
Me-Ow (M. B. Kaufman). One-step. Violin and piano duet. Jockers Brothers
A6075 Oriental (Rose). One-step, Earl Fuller's Rector Novelty Orchestra
Texas (Guion). Fox-trot, Earl Fuller's Rector Novelty Orchestra
A6068 Sailor's Joy—Part 1 (Schlegel). Quadrille. Prompting by John H. Haselton. Prince's Orchestra
Sailor's Joy—Part 2 (Schlegel). Quadrille. Prompting by John H. Haselton. Prince's Orchestra
A6077 Smiles (Roberts). Medley Fox-trot. Introducing "Mandy and Me" (Gumble). Prince's Band
When You Come Back, and You Will Come Back (There's the Whole World Waiting for You) (Cohan). Medley One-step. Intro. (1) "Daddy Mine" (Wilson and Dubin); (2) "Good-bye, Mother Machree" (Ball); (3) "Some Day They're Coming Home Again" (Hilbert). Prince's Band
A2626 Submarine Attack Somewhere at Sea. Male voices. (Descriptive). Peerless Quartet
The Battle in the Air (Campbell, Morse and Collins). Male voices. (Descriptive). Peerless Quartet

- A2627 A Slippery Place (Hacker). Comic Rag. Under the direction of T. F. Shannon, Naval Reserve Band
Hilda's Wedding (Armstrong). Under the direction of T. F. Shannon, Naval Reserve Band
A2633 Spring Song (Mendelssohn). Flute, cello and harp. Trio de Lutece
Minuet (Beethoven). Flute, cello and harp. Trio de Lutece
A2631 My Irish Song of Songs (from "Once Upon a Time") (Sullivan). Tenor solo, orch. accomp., Charles Harrison
The Fields o' Ballyclare (Turner-Maley). Tenor solo, orch. accomp., Charles Harrison
A7524 The Joy of the Beautiful Pine. Children's story with chimes and orchestra, Thornton W. Burgess
Johnny Chuck Finds the Best Thing in the World. Children's story from "Old Mother West Wind" (Little, Brown & Co.), Thornton W. Burgess
E4038 Gold and Silver Waltz. Gypsy Orchestra
When I Am Crying for You. Gypsy Orchestra

VICTOR TALKING MACHINE CO.

- SELECTED LIST OF BEST SELLERS
Issued in Lieu of the Usual List of New Records
In order to effect a considerable increase in the supply of records which are and which have been in the greatest demand, this specially selected list of best sellers is offered to the public for the month of December, 1918. There can be no uncertainty in the matter of orders, because a nationwide demand for these particular records already exists.
16996 Adeste Fideles (Oh, Come, All Ye Faithful) (Oakeley-Portugal). With chimes, Trinity Choir
Joy to the World (Watts-Handel). Christmas Hymn. Trinity Choir
17767 Hilo. Hawaiian March. Irene West Royal Hawaiians
Wailana Waltz. Hawaiian Guitars, K. K. K. David Kaili
18029 Coben at the Telephone. Comic Monologue, Barney Bernard
Goldstein Goes in the Railroad Business, Barney Bernard
18389 Silent Night, Holy Night (Gruber). Violin, harp, flute. Neapolitan Trio
Christmas Hymns—Selection. Harp. "While Shepherds Watched Their Flocks by Night," "It Came Upon the Midnight Clear," "Silent Night," "Adeste Fideles" (O Come, All Ye Faithful). Francis J. Lapitino
18430 U. S. Field Artillery March (Sousa), Sousa's Band
18439 Liberty Loan March (Sousa). Sousa's Band
Just a Baby's Prayer at Twilight (Lewis-Young-Terome). Henry Burr
On the Road to Home, Sweet Home (Kahn Van Alstyne). Percy Hemus
18455 The Last Long Mile (Breitenfeld). Charles Hart and Shannon Four
K-K-K-Katy (O'Hara). Billy Murray
18462 I'm Sorry I Made You Cry (N. J. Clesi), Henry Burr
One Day in June (Joe Goodwin-James F. Hanley). Campbell and Burr
18473 Smiles (Lee Roberts). Fox-trot, Joseph C. Smith's Orchestra
Rose Room (Hickman-Smith). Fox-trot. Intro. "My Oriental Rosebud," Joseph C. Smith's Orchestra
18483 Bluin' the Blues (Ragas). Fox-trot, Original Dixieland Jazz Band
Sensation Rag (Edwards). One-step, Original Dixieland Jazz Band
18489 Oh! How I Hate to Get Up in the Morning (Irving Berlin). Arthur Fields
Oh! Frenchy! (Ehrlich-Conrad). Arthur Fields
18494 For Your Boy and My Boy (Kahn-Van Alstyne), Peerless Quartet
When You Come Back (Cohan), Raymond Dixon and Orpheus Quartet
35412 While Shepherds Watched (Tate-Handel), Victor Oratorio Chorus
It Came Upon the Midnight Clear (Willis), Victor Oratorio Chorus
35594 Angels from the Realms of Glory (Montgomery-Smart). Christmas Hymn (Tune "Regent Square"), Trinity Choir
Oh, Little Town of Bethlehem. Christmas Hymn. Trinity Choir
35661 Sing, O Heavens (Berthold Tours), Victor Mixed Chorus
It Came Upon the Midnight Clear (Willis), Victor Mixed Chorus
35663 Missouri Waltz. Joseph C. Smith's Orchestra
Kiss Me Again (Herbert). Waltz, Joseph C. Smith's Orchestra
45135 Star Spangled Banner (Key-Arnold), Reinald Werrenrath
America (Smith-Carcy). Reinald Werrenrath
45145 Holy Night (Cantique de Noel) (Adam). With Lyric Quartet. Lucy Marsh
Silent Night, Holy Night (Gruher). Lyric Quartet
45153 France, We Have Not Forgotten You (Clarke-Rogers-Ager). Lamhert Murphy
I'll Pray for You (Lockton-St. Quentin). Olive Kline
55066 Lucia (Donizetti). Sextet. Victor Opera Sextet
Rigoletto (Verdi). Quartet, Victor Opera Quartet
55093 American Fantasie—Part 1—"Hail Columbia!" "The Old Folks at Home," Victor Herbert's Orchestra
American Fantasie—Part 2—"The Girl I Left Behind Me," "Dixie," "Columbia, the Gem of the Ocean," "Star Spangled Banner," Victor Herbert's Orchestra
64637 Dixie (Emmett). With Victor Male Chorus, Mahel Garrison
64688 All the World Will be Jealous of Me (Dubin-Ball). Emilio de Gogorza
64693 La Marseillaise (National Air of France). French, with Metropolitan Opera Chorus
64696 Keep the Home-Fires Burning (Ford-Novello), John McCormack
64708 The Sweetest Story Ever Told (R. M. Stults), Sophie Braslau
70061 Roamin' in the Gloamin'. Scotch Specialty, Harry Lauder
74163 Humoresque (Dvorak). Violin. Mischa Elman
74198 Open the Gates of the Temple (Knapp), Evan Williams
74420 Carry Me Back to Old Virginia (Bland), Gluck and Male Chorus
74424 Aida—Celeste Aida (Heavenly Aida) (Verdi). Italian. Giovanni Martinelli
74425 I'll Take You Home Again, Kathleen (Westendorf). Clarence Whitehill
74436 Adeste Fideles (Oh, Come, All Ye Faithful) (Portugal). Christmas hymn. Latin, with chimes. John McCormack with Male Chorus

- 74467 Harlequin's Serenade (from "Les Millions d'Arlequin") (Drigo). Violin. Erem Zimbalist
74509 Lucia—Mad Scene (Donizetti). (Flute obligato by Barone). Italian. Amelita Galli-Curci
74533 Minuet in G (Op. 14, No. 1) (Paderewski). Piano. Paderewski
74563 Ave Maria (Schubert-Wilbelm). Violin, Jascha Heifetz
87107 Whispering Hope (Hawthorne), Alma Gluck and Louise Homer
87221 The Rosary (Nevin). Ernestine Schumann-Heink
87264 Where is My Boy To-Night (Lowry). Gospel hymn. Louise Homer
87294 Over There (Cohan). First verse. English; second verse French. Enrico Caruso
88113 Madama Butterfly—Un bel di vedremo (Some Day He'll Come) (Puccini). In Italian, Geraldine Farrar
88561 Noel (Holy Night) (Adam). French, Enrico Caruso

EDISON AMBEROL RECORDS

- ROYAL PURPLE RECORDS
29012 Just As I Am (Wm. D. Bradbury). Orch. accomp., Arthur Middleton
29013 Theme and Variations (Proch). Soprano, orch. accomp., Frieda Hempel
REGULAR LIST
3619 Ambrose and Steve in Court. Vaudeville Sketch, Billy Golden and Kelly Heins
3618 Battle in the Air (Tbo. Morse), Premier Quartet and Company
3611 Donna Juanita Selection (F. von Suppe), Creator and His Band
3617 Everything Is Peaches Down In Georgia (Ager-Smyer). Arthur Collins and Byron G. Harlan
3609 From Tropic to Tropic March (Russel Alexander). New York Military Band
3603 General Pershing March (Carl D. Vandersloot), Imperial Marimba Band
3612 Good-Bye, Alexander (Creamer-Layton). Coon Song, orch. accomp., Ada Jones
3616 Hawaiian Breezes Waltz, Waikiki Hawaiian Orchestra (with Louise and Ferrara)
3604 Howdy! One-step for dancing, Jaudas' Society Orchestra
3610 Jazz de Luxe—Fox-trot (Earl Fuller), Earl Fuller's Famous Jazz Band
3607 Most Beautiful Picture of All (May Hill), Tenor, orch. accomp., Manuel Romain
3620 Night, My Love and I (H. Sylvester Krouse), Tenor, orch. accomp., Vernon Dalhart
3601 Oh! Frenchy (Con Conrad). Baritone, orch. accomp., Arthur Fields
3613 Smiles (Lee S. Roberts). Mixed Voices, orch. accomp., Harmony Four
3615 Smiles Fox-trot (Lee S. Roberts). For dancing, Jaudas' Society Orchestra
3621 Song of Ages—Christmas Song (I. H. Meredith). Sacred, orch. accomp., Metropolitan Quartet
3606 Sweet Hawaiian Moonlight (Tell Her of My Love) (F. Henri Klickmann). Soprano and Contralto, orch. accomp., Gladys Rice and Marion Evelyn Cox
3602 Uncle Sammy—Vocal March (Abe Holzmann). Male Voices, orch. accomp., Premier Quartet
3614 Watch the Bee Go Get the Hun (Walter Hawley). Comic song, orch. accomp., Edward Meeker
3605 Whenever I Think of You (Charles N. Grant). Soprano, orch. accomp., Betty Lane Shepherd
3608 When I Send You a Picture of Berlin Medley—One-step, for dancing, Jaudas' Society Orchestra
FRENCH SELECTIONS
27183 (a) Madrigal; (b) Tu me diras (If thou dost say), (C. Chaminade). Tenor, in French, orch. accomp., P. A. Asselin
27182 Cantique de Noel (O Holy Night), (Adolphe Adam). Tenor, in French, orch. accomp., P. A. Asselin

EDISON RE-CREATIONS

- 82136 Mad Scene—Lucia di Lammermoor (Donizetti). Soprano, in Italian—Flute Obligato. Anna Case
82139—Come Unto Him—Messiah (Handel). Soprano, Marie Tiffany
There's a Beautiful Land on High (A. H. Taylor). Soprano. Marie Tiffany
80379—Hush-a-hye, Ma Baby (Missouri Waltz) (Fred-eric Knight Logan). Contralto and Tenor, Marion Evelyn Cox and Vernon Dalbart
Longing for My Dixie Home (J. R. Shannon). Tenor and Chorus. Harvey Hindermeyer
80397—A Little Love, a Little Kiss (Lao Siles). Tenor. Ralph Errolle
One Fleeting Hour (Dorothy Lee). Soprano, Gladys Rise
80398—My Waikiki Mermaid—Hula Medley, Waikiki Hawaiian Orchestra
Valse Llewellyn (Wiedoeft). Saxophone, Rudy Wiedoeft
80408—Fantasia—Impromptu (Chopin). Piano, André Benoist
80409—Work, for the Night Is Coming (Mason); Jesus, Saviour, Pilot Me (J. E. Gould). Sacred, Metropolitan Quartet
Throw Out the Life-Line (E. S. Ufford). Sacred. Metropolitan Quartet
80410—Inflammatus—Stabat Mater (Rossini). Cornet, Pietro Capodiferro
La Paloma (Yradier). Sodero's Band
80411—Old Virginny Days (Theodore Morse). First Soprano, Second Soprano and Alto, Homestead Trio
When I'm Gone You'll Soon Forget (E. Austin Keith). Tenor and Contralto, Walter Van Brunt and Helen Clark
50480—Molly Dear Waltz (Arthur De Blon). For Dancing. Jaudas' Society Orchestra
"Old Timers" Waltz—For Dancing, Jaudas' Society Orchestra
50482—Invincible American March (F. H. Losey), New York Military Band
Wisconsin Forward Forever March, New York Military Band
50485—Farmyard Medley—Descriptive Sketch, Premier Quartet
Study in Mimicry—Vaudeville Sketch, John Orren and Lillian Drév
82145—Freedom for All Forever (B. C. Hilliam). Baritone and Chorus. Arthur Middleton
There's a Long, Long Trail (Zo Elliott). Soprano and Male Voices, Frieda Hempel and Criterion Quartet
50489—Ding! Bang! Bing! em on the Rhine (Mahoney Flynn). Male Voices. Premier Quartet
Last Long Mile—Toot-Toot (Lieut. E. Breitenfeld). With Chorus. Billy Murray
50490—K-K-K-Katy (Geoffrey O'Hara). With Chorus, Billy Murray
Submarine Attack (Theodore Morse), Premier Quartet and Company
50494—Bring Me a Letter From My Old Home Town (Will R. Anderson). Tenor. Reese Jones
We'll Do Our Share (While You're Over There) (Jack Egan). Mixed Voices. The Harmony Four
(Continued on page 114)

RECORD BULLETINS FOR DECEMBER (Continued from page 113)

50495—We're All Going Calling on the Kaiser (Cadingan-Brennan). Baritone and Chorus, Arthur Fields

PATHE FRERES PHONOGRAPH CO.

POPULAR "HITS" OF THE MONTH 20444*On the Level, You're a Little Devil (from "Winter Garden Show") (Schwartz), Louis Winsch, Baritone, 10

20446*A Little Birch Canoe and You (Callahan-Roberts).....Sterling Trio 10 Garden of My Dreams (from "Follies of 1918") (Hirsch-Stamper).....Henry Burr, Tenor 10

NEW SACRED RECORDS

40141 The Birthday of a King (Neidlinger). Organ accomp. B. Stonehill, Baritone 12 Hear Me, Ye Winds and Waves (Handel), B. Stonehill, Baritone 12

NEW PATHE "DE LUXE" DANCE RECORDS

20449*Valse Parisienne (Roberts), American Republic Band 10 Remick's "Hit" Medley. Intro. "Wondrous Eyes of Araby," "It Might as Well be You," and "Mandy and Me." Fox-trot, American Republic Band 10

NEW BAND RECORDS

20451 High School Cadets (Sousa), American Regimental Band 10 The Liberty Bell (Sousa), American Regimental Band 10

NEW OPERATIC RECORDS

54020 Le Regiment de Samhre et Meuse (Planquette) (French National Marching Song) in French, Lucien Muratore, Tenor 12

NEW INSTRUMENTAL NOVELTIES

20453 Bells of May (Dittrich). Mazurka, with bells, Pathé Freres Orchestra 10 Christmas (Margis). Valse, with bells, Pathé Freres Orchestra 10

FOR HOLIDAY TRADE

The following ten records, selected from the Pathé Catalog, which will furnish choice entertainment during the coming season of Christmas and the New Year, will be re-listed in the regular December Supplements.

25018 God be With Our Boys To-night (Sanderson), Craig Campbell, Tenor 10 Roses of Picardy (Wood). Craig Campbell, Tenor 10

EMERSON PHONOGRAPH CO.

THE NEW SEVEN-INCH RECORDS PATRIOTIC AND POPULAR SONG HITS 7419 Oh! How I Wish I Could Sleep Until My Daddy Comes Home (Lewis-Young-Wending). Patriotic ballad, orch. accomp. Robert Rice

DANCE HITS

7428 Mary (Stoddard-Frey). Fox-trot, Emerson Military Band 7425 When You Come Back, Bring Me a Letter from My Old Home Town (Cohan-Anderson). Medley. Banjo, piano and saxophone, Van Eps-Banta Trio

LATEST OKEH RECORDS

1095 After You've Gone.....Irving Kaufman 1096 Everything Is Peaches Down in Georgia, Collins and Harlan

SONGS OF THE CHRISTMAS SEASON

50005 Silent Night (Gruber). Quartet with chimes, Peerless Quartet 50004 Adeste Fideles (Oakeley-Portugal). Chorus and chime, Royal Chorus

RECORDS FOR DANCING

30074 Smiles (Roberts-Callahan)—Fox-trot, Paramount Dance Orchestra 30074 Djer Kiss (Milton Ager). Waltz hesitation, Paramount Dance Orchestra

SONGS OF THE CHRISTMAS SEASON

50005 Silent Night (Gruber). Quartet with chimes, Peerless Quartet 50004 Adeste Fideles (Oakeley-Portugal). Chorus and chime, Royal Chorus

RECORDS FOR DANCING

30074 Smiles (Roberts-Callahan)—Fox-trot, Paramount Dance Orchestra 30074 Djer Kiss (Milton Ager). Waltz hesitation, Paramount Dance Orchestra



Where Dealers May Secure

COLUMBIA

Product

Ready, Full Stocks, and Prompt Deliveries from Convenient Shipping Centers all over the United States.

Distributors

- Atlanta, Ga., Columbia Graphophone Co., 63 N. Pryor St. Baltimore, Md., Columbia Graphophone Co., 16 South Howard St. Boston, Columbia Graphophone Co., 137 Federal St.

Executive Office

COLUMBIA GRAPHOPHONE CO. Woolworth Building New York

All Out of Step But Jim—You're the Greatest Little Mother in the World, Walter Roger's Band Rock-a-Bye Your Baby with a Dixie Melody—Medley fox-trot. Consists of—Rock-a-Bye Your Baby with a Dixie Melody—Hello Central, Give Me No-Man's Land—When Alexander Takes His Ragtime Band to France—I Hate to Lose You.....Roger's Band

Some Leading Jobbers of Talking Machines in America

1856 **WURLITZER** 1916
VICTOR
 DISTRIBUTORS
 VICTORS EXCLUSIVELY
We make a specialty of getting the order out on time—every time.
The Rudolph Wurlitzer Co.
 CINCINNATI AND CHICAGO
Two points of supply; order from the nearer

TEST IT. 
 OUR VICTOR
Record Service
 has a reputation for efficiency.
 Suppose you try it.
E. F. DROOP & SONS CO.
 1300 G. STREET, WASHINGTON, D. C.
 231 N. HOWARD STREET, BALTIMORE, MD



YAHR & LANGE DRUG CO.
 MILWAUKEE, WIS.
 Wholesale Distributors for
 THE INSTRUMENT OF QUALITY
Sonora
 CLEAR AS A BELL 
 in Wisconsin
 and Upper Michigan

W. J. DYER & BRO.
 NORTHWESTERN DISTRIBUTORS
 OF THE
VICTOR
 Machines, Records and Supplies

 Shipped Promptly to all
 Points in the Northwest

STARR Phonographs
 and **GENNETT Records**
 Complete Stock and REAL Service
Crafts-Starr
 PHONOGRAPH CO.
 Factory Distributors
 218-220 NORTH SECOND STREET, RICHMOND, VIRGINIA
 Write for Dealers' Proposition

Smith, Kline & French Co.
 PHILADELPHIA
 Wholesale Distributors for
 THE INSTRUMENT OF QUALITY
Sonora
 CLEAR AS A BELL 
 In PENNSYLVANIA, NEW JERSEY
 and DELAWARE

Hillman & Son Phonograph Co.
 Wheeling, West Virginia
 Exclusive Wholesale Distributors for West
 Virginia and Virginia
 THE INSTRUMENT OF QUALITY
Sonora
 CLEAR AS A BELL 
 All models shipped promptly from our large
 warehouse, 1126 Main Street
 Diamond Needles and Sapphire Needles for Sale

Strevell-Paterson Hdw. Co.
 Wholesale Distributors
 for
 Utah, Idaho, Colorado, Wyoming
 and New Mexico
 THE INSTRUMENT OF QUALITY
Sonora
 CLEAR AS A BELL 
 Complete Stock on Hand at All Times
 SALT LAKE CITY UTAH

C. L. Marshall & Co.
 Wholesale Distributors
 for Michigan
 THE INSTRUMENT OF QUALITY
Sonora
 CLEAR AS A BELL 
The Ohio Sales Company, Inc.
 Wholesale Distributors
 for Ohio
 810-11 EMPIRE BLDG., DETROIT, MICH.

Mickel Bros. Co.
 Omaha, Nebraska
 Des Moines, Iowa
Victor Distributors

Southern Victor Dealers
 Largest Stock VICTROLAS and RECORDS.
 Prompt Shipments and Low Freight Rates.
WALTER D. MOSES & CO.
 Oldest Music House in Virginia or North Carolina.
 RICHMOND, VA.

OLIVER DITSON COMPANY
 BOSTON
 Largest VICTOR Talking
 Machine Distributors East of
 Chicago.
 Creators of "The Fastest Victor
 Service." Let us tell you more
 about our service.

Sherman, Clay & Co.

 San Francisco, Los Angeles, Portland, Seattle, Spokane
 PACIFIC COAST DISTRIBUTORS OF
 VICTOR PRODUCTS

The PERRY B. WHITSIT CO.
 Distributors of
 Victrolas and Victor Records
 COLUMBUS, OHIO

ROUNTREE-CHERRY
 RICHMOND VIRGINIA
 Wholesale Distributors for
 THE INSTRUMENT OF QUALITY
Sonora
 CLEAR AS A BELL 
You
 above all must be satisfied!
 IN NORTH AND SOUTH CAROLINA

The Electric Supply & Equipment Co.
 Exclusive Wholesale Distributors for
 Southern New England
 THE INSTRUMENT OF QUALITY
Sonora
 CLEAR AS A BELL 
 Complete stocks carried in Boston and Hartford
 Little Bldg. 103 Allyn St.
 BOSTON, MASS. HARTFORD, CONN.

*Have You Noted the Growth of
 This Department?*
**Special Rates for Jobbers' Direc-
 tory on Application**
 During the past six months this Jobbers'
 Directory has grown steadily in importance.
 It affords progressive jobbers an opportunity
 to keep their names before the dealers con-
 sistent and regularly, and provides repre-
 sentation in the Jobbers' Directory of the
 publication which is the recognized authority
 of the industry.
 Join the progressive jobbers on this page
 next month.

Victor Exclusively
EASTERN TALKING MACHINE CO.
 177 Tremont Street, Boston
VICTOR DISTRIBUTORS

THE NEW EDISON



A Master Product of A Master Mind

JOBBER OF THE NEW EDISON, EDISON RE-CREATIONS, THE NEW EDISON DIAMOND AMBEROLA AND BLUE AMBEROL RECORDS

CALIFORNIA
Los Angeles—Edison Phonographs, Ltd.
San Francisco—Edison Phonographs, Ltd.

COLORADO
Denver—Denver Dry Goods Co.

CONNECTICUT
New Haven—Pardee-Ellenberger Co., Inc.

GEORGIA
Atlanta—Phonographs, Inc.

ILLINOIS
Chicago—The Phonograph Co.
James I. Lyons. (Amberola only.)

INDIANA
Indianapolis—Kipp Phonograph Co.

IOWA
Des Moines—Harger & Blish.
Sioux City—Harger & Blish.

LOUISIANA
New Orleans—Diamond Music Co., Inc.

MASSACHUSETTS
Boston—Pardee-Ellenberger Co.

MICHIGAN
Detroit—Phonograph Co., of Detroit.

MINNESOTA
Minneapolis—Laurence H. Lucker.

MISSOURI
Kansas City—The Phonograph Co. of Kansas City.
St. Louis—Silverstone Music Co.

MONTANA
Helena—Montana Phonograph Co.

NEBRASKA
Omaha—Shultz Bros.

NEW JERSEY
Paterson—James K. O'Dea (Amberola only).

NEW YORK
Albany—American Phonograph Co.

New York—The Phonograph Corp. of Manhattan.
Syracuse—Frank E. Bolway & Son, Inc.
W. D. Andrews Co. (Amberola only.)
Buffalo—W. D. & C. N. Andrews Co. (Amberola only.)

OHIO
Cincinnati—The Phonograph Co.
Cleveland—The Phonograph Co.

OREGON
Portland—Edison Phonographs, Ltd.

PENNSYLVANIA
Philadelphia—Girard Phonograph Co.
Pittsburgh—Buehn Phonograph Co.
Williamsport—W. A. Myers.

RHODE ISLAND
Providence—J. A. Foster Co. (Amberola only.)

TEXAS
Dallas—Texas-Oklahoma Phonograph Co.

UTAH
Ogden—Proudfit Sporting Goods Co.

VIRGINIA
Richmond—The C. B. Haynes Co., Inc.

WISCONSIN
Milwaukee—The Phonograph Co. of Milwaukee.

CANADA
Montreal—R. S. Williams & Sons Co., Ltd.
St. John—W. H. Thorne & Co., Ltd.
Toronto—R. S. Williams & Sons Co., Ltd.
Vancouver—Kent Piano Co., Ltd.
Winnipeg—R. S. Williams & Sons Co., Ltd.
Calgary—R. S. Williams & Sons Co., Ltd.

The TALKING MACHINE WORLD

For the
makers &
sellers of
talking
machines

Published Each Month by Edward Lyman Bill, Inc., at 373 Fourth Ave., New York, December 15, 1918



The best-known trade-mark in the world

"The Victor talking machine's design, 'His Master's Voice,' has become a household word, and the quaint little fox terrier at attention before the horn is familiar to more Americans than any of the world's great masterpieces"—*Collier's Weekly*.

The Highest Class Talking Machine in the World



WITH the resumption of the normal peace-time production of phonographs, the wide-awake dealer will immediately try to secure the agency for the wonderful Sonora, internationally famous for winning the highest score for tone quality at the Panama Pacific Exposition.

With largely increased factory facilities we shall be able to take care of more dealers than we have in the past, but we desire particularly to emphasize that the Sonora is distinctly a phonograph *of the very highest grade and its matchless tone and improved features of construction are our first thought; quantity manufacturing is never given precedence or placed on a par with quality maintenance.*

Sonora sets the highest standards and upholds them.

Write us regarding an agency in your territory. We offer an unequaled line of standard upright and period models at prices ranging from \$50 to \$1000.

Sonora Phonograph Sales Company, Inc.

GEORGE E. BRIGHTSON, *President*

Executive offices: 279 Broadway, New York

Demonstration Salons, New York: Fifth Avenue at 53rd St. 50 Broadway (Standard Arcade)

Philadelphia: 1311 Walnut Street *Canadian Headquarters:* Ryrie Building, Toronto

Export Department: 417 West 28th Street, New York, U. S. A.

*To get the best results use only the
new Sonora Semi-Permanent Silvered
Needles with Steel Needle Records*

CAUTION: Beware of similarly constructed needles of inferior quality.

The Talking Machine World

Vol. 14. No. 12

New York, December 15, 1918

Price Twenty-five Cents

HOW THE TRADE MAY PROFIT FROM LESSONS OF THE WAR

The War Has Been a Wonderful Though Strict Teacher—Has Brought About Improvements in Selling Methods, Developments in the Matter of Economies, Elimination of Trade and Other Evils—Editorial Comments in This Connection That Are Proffered With Best Intentions

It has been said frequently for generations, but will still bear repeating, that "experience is the best teacher"; but some people, including a goodly proportion of business men, cannot even learn through experience, due not so much to lack of intelligence as to carelessness in taking due stock of the lessons thus learned.

For the men in the peace-time industries in America, the war has been a wonderful, though strict teacher, for war conditions brought about overnight, practically, improvements in selling methods, great developments in the matter of economies, and likewise the elimination of trade evils, all of which have been discussed for years with a full realization of their importance, but regarding which nothing was done in normal times.

In the talking machine trade, for instance, as a result of the war there was a general shortening of terms in the retail field and an insistent demand for cash, due to two reasons: first, that the dealer must have cash with which to discount his bills and secure a larger percentage of the limited supply of goods, and, secondly, because the limited supply of goods developed a buyer's market and made it possible for the dealer, to insist upon cash or terms that approximated cash, with the assurance that he could get it without any great difficulty.

Revolution in Selling Methods

The war has also brought about some other revolutions in selling methods. We have had real salesmen and saleswomen in the trade since its inception, and their work stands out clear, but there was, unfortunately, too great a proportion of those who found that talking machines and records, due to the tremendous advertising and exploitation campaigns of the manufacturers, came close to selling themselves. This proportion of dealers and their help therefore were inclined to let nature take its course, seeing that they could do a sufficient volume of business without exerting themselves to any great extent.

While the popular models of machines and the most popular records were plentiful, this system worked out fairly well, but when war conditions came the careless ones found that they really had to sell their goods, particularly records. They had to delve into their racks and bring forth records that had not seen the light of day since first taken from the shipping case. They had to study those records and describe them so alluringly that the customer simply had to buy. Many of them found for the first time that intensive salesmanship really had a place in the talking machine store. The result has been that throughout the country there are smaller stocks of what may be termed "slow-selling or dead records" than ever before in the history of the trade.

Lessons That Should Not Be Forgotten

These lessons of proper terms and energetic selling have been learned at considerable expense and under the goad of necessity. The dealer had to get cash and move his old stock, or shut up his shop, because he could not depend for his turnover on new goods entirely, as in normal times. Are these lessons going to be forgotten or ignored with the return of normal conditions? Are the dealers going to neglect this great opportunity for putting their businesses on the healthiest basis possible in the history of the industry? Having learned to clean house, are they going to let their books be given over to long-time contracts and their shelves given over to stock that sticks simply because it isn't sold and the customers don't demand it? It is safe to say that some dealers

will forget this lesson, but equally safe to say that so many of them will take it to heart and will continue to practice the first-class selling methods in vogue in other industries, where selling is a necessity rather than an accomplishment, that the followers of the old-time methods will be put to the test to hold on.

Elasticity in Supply Situation Helps

The loosening up of the supply situation will, of course, be welcome, but it is going to be a gradual loosening up. The material markets in the first place must be adjusted, so that manufacturers can get their normal supplies under normal conditions, and this work can not be done overnight. Then it is going to take time to return war workers to the pursuits of peace; to fit them into place in talking machine factories before all the machinery of production is running smoothly again. This may take several months or a year or more. Therefore, complete relief cannot be expected on the first of the year or shortly thereafter. The observance of cash in short-time selling must therefore be continued as a matter of self-protection. Likewise the practice of real salesmanship must also be continued to keep stocks adjusted and to prevent tying up of essential capital in the store-room or the record shelves. After that, the

MONTHLY MEETINGS OF DEALERS

Frank E. Bolway, Edison Jobber, Adopts That Plan in Preference to the Annual Convention—Salesmen Demonstrate Their Methods

"Frank E. Bolway, of Syracuse, is trying out a new substitute for the annual convention this year," says the Edison Diamond Points. "He holds monthly meetings of the dealers in his district for the purpose of comparing notes, giving suggestions and keeping everyone in touch with the splendid ideas which any of the others may have acquired. These monthly meetings are held in the Syracuse jobbing establishment, and the addresses are by members of the staff of the Rochester and Syracuse stores. Several dealers are invited each month as guests of the establishment. The subjects under discussion cover all sorts of problems of the Edison trade, and are dealt with by Mr. Bolway's expert salesmen.

"J. G. Brown, Mr. Bolway's right-hand man, who was in the office the other day, informs us that all their salesmen are A Number 1. If they are not it is not Mr. Bolway's fault, nor Mr. Brown's. They are two of the most wideawake, up-to-date, enthusiastic salesmen who ever went out after business. They give every man in their employ full opportunity to benefit by the combined experience of all their colleagues. Co-operation is the keynote of the establishment. The understanding between the salesmen and their superiors and among the salesmen themselves is complete. Mr. Bolway has arranged frequent meetings among the staffs of the different stores to provide for this understanding. At any time in the course of one of these meetings any salesman may be called upon to demonstrate his method of handling a certain problem, illustrated by another salesman who takes the part of a difficult customer. Mr. Brown informs us that the men are keen for these 'rehearsals,' and derive a great deal of benefit from their effective presentation.

"T. J. Leonard, who attended the 'Bolway Syndicate Meeting' in Syracuse on October 1, is very enthusiastic about the monthly meeting idea. The dealers are not frightened off from attending by being asked to make talks or read papers; that is done by various members of the

dealer who has learned his lesson thoroughly is going to find that he will view every record in stock as a liquid asset, not simply carried for the sake of saying that he has a complete line of records, but carried because he expects to sell it with proper effort, and likewise expects to put forth that proper effort.

Value of Cash Business

In the matter of terms, it can be said that the foresighted dealer has learned the value of cash. It has been a bitter lesson to some, but, nevertheless, it has been learned. The public, too, has without doubt received a new impression of talking machine values; has learned that the instruments are worth something in actual cash and must be bought on terms that will enable the retailer to clean up the sale quickly. There is no reason in the world why credit of eighteen months or more should be given on a sale totaling approximately \$100. The customer who demands that much credit had better buy a lower-priced machine or wait until such time as he is financially in a position to assume the obligation in proper form. Likewise, machines selling at \$30, \$50 or even \$60 in these days of high prices should not be sent out on terms that represent little more than bank interest on the dealer's money.

Let the lessons of the war be kept in the forefront. Make the cost of the lessons pay dividends. It will mean a cleaner, healthier trade as well as more profits, quicker assets and a local business life for the dealer.

sales staff, and the papers that I heard were brief and pointed. There were no long and wearisome talks. In consequence, things moved with a snap, and the evening passed very quickly,' he comments.

"The guests at the latest meeting were T. J. Leonard, general sales manager, Thomas A. Edison, Inc.; L. S. Wright, of the Sheldon School of Salesmanship; E. A. Agens, dealer at Lowville, N. Y.; A. Stettenbenz, of the Utley Piano Co., Inc., dealer at Buffalo, N. Y.; C. J. Hereth, dealer at Buffalo, N. Y.; W. C. Morgan, dealer at Fulton, N. Y."

NEW VOCALION REPRESENTATIVES

Important Retail Houses Take Agency For This Instrument—Arrangements Made By Aeolian Co.'s Branch Located in St. Louis

St. Louis, Mo., Dec. 8.—F. F. Stevenson, manager of the wholesale Aeolian Vocalion department in the Aeolian branch in this city, stated this week to a representative of The World that a number of important deals had been closed during the past few weeks whereby the Aeolian Vocalion line will be handled by representative dealers in this territory. Among these new Vocalion representatives are the following: Parker Dry Goods Co., Charleston, Ill.; J. W. Milligan, Carbondale, Ill.; Lehman Music Co., East St. Louis, Ill.; Tuxhorn Bros. Hardware Co., Edwardsville, Ill.; Feraud Bros., Granite City, Ill.; Gemlich & Schmidt, Boonville, Mo.; John N. Taylor, Columbia, Mo.; George Porth, Jefferson City, Mo.; Park's Music House Co., Louisiana, Mo.

Mr. Stevenson also stated that new dealers for the Vocalion line have been appointed in Kansas, Oklahoma and Arkansas, and the new Vocalion record is meeting with an enthusiastic reception from Vocalion representatives throughout this territory.

SECURES SONORA AGENCY

The Fortune-Ward Drug Co., of Memphis, Tenn., has secured the agency for the Sonora talking machine, and will devote the entire second floor of its establishment to its exploitation.

Maintaining the Efficiency of the Mailing List By Eliminating All the Deadwood

The advantages accruing to the talking machine dealer through having a live, up-to-date mailing list have often been manifested, but never in the history of the trade has it been so necessary as now for the dealer to see that his list is actually live, and that the deadwood is eliminated so far as it is possible to do so. In normal times the waste that comes from carrying dead names on the mailing list is to be condemned, even though often winked at, but in these days of paper shortage, increasing overhead expenses, and the request of the Government for conservation all along the line, to carry a mailing list that is not up-to-the-minute is little short of criminal. Mailing costs have gone up, especially on first-class matter, and printing is more expensive. The literature for mailing is costing from 50 per cent. to 100 per cent. more than formerly and every factor connected with keeping the mailing list going has grown more costly.

It must be remembered, however, that the mailing list will not keep itself free from deadwood automatically. It must be watched, and watched carefully, and thinned out at frequent intervals. The dealer who keeps no record of his mailing list, and the direct results it brings, can tell almost offhand those names on the list which represent live customers—those who make use of the lists and other matter sent to guide them in their regular purchases. These names must, of course, stay on, and be carefully guarded. Then there are those who make purchases semi-occasionally, and of a nature to indicate that some particular piece of literature has appealed to them, and has induced them to buy. By carefully checking up the purchasers of this class, the dealer is likely to find he can save a considerable part of his postage bill by sending to them only literature regarding records and other items in which experience tells him they will be most likely to be interested.

Next separate the old customers—those who have been more or less regular in their buying in the past, but who, for one reason or another, have fallen by the wayside. By removing them from the regular mailing list and giving them special attention the dealer can either rejuvenate their interest in their machines and put them back in the live class, or learn definitely if their interest has waned entirely, which, under the circumstances, means that as a matter of fact

it will be real economy to let them severely alone.

To the doubtful names—and every list contains dozens or hundreds—send a return postcard enclosed in a circular, or folder, explaining that the dealer's list is being revised; that he wants to put into it information that will assist him in sending to the customer, or prospective customer, material that will prove most interesting, and asking that the card be returned with that information. The general rule is to have the name of the prospective customer

*This Is No Time
to Waste Effort
and Postage On
a Dead List....*

already written on the return card, leaving space for the present address, make and type of machine, and class of records in which the prospective customer is most interested. Those who do not return the cards can be taken off the list. A careful survey of the information contained on the cards that are returned will permit the conservative dealer to eliminate even some of these names from his list, to allow room for some liver prospect.

Return postcards, together with a circular letter and envelope, and the first cost of mailing, may appear to be an expensive proposition, but it will be found that the number of names that can be cut off the list after this work is done will represent, in the saving of expensive exploitation literature, a sum many times the cost of the campaign.

Under present conditions the dealer finds that he cannot afford to let his salesmen waste time on doubtful prospects, for as a rule he has not sufficient stock to take care of the live customers. His mailing list is a salesman, and it should have on it only the names of those who

are ready and willing to do business. The other kind can wait until stock is more plentiful, and salesmen have more time.

CANCEL INCREASED PRICE LIST

Columbia Graphophone Co. Issue Important Announcement Regarding Cut in Curtailment—Restore Old Prices on All Machines

The Columbia Graphophone Co. sent out on November 16 to their dealers a copy of a telegram sent to Columbia business managers announcing the fact that the new and increased price list for Grafonolas which went into effect on November 1 had been canceled, and that all November shipments since November 1 will be rebilled at the old prices. The telegram to Columbia branch managers, which was signed by George W. Hopkins, general sales manager, read as follows:

"Due to the announcement to-day of the War Industries Board of the Government that the curtailment of the production of phonographs is cut from 60 per cent. to 30 per cent., we are glad to be able to reinstate prices as in force prior to November 1, 1918, with instructions to you to rebill all November shipments at the old prices."

BELIEVES IN VALUE OF SERVICE

M. B. Silverman, of the Mandel Mfg. Co., of Chicago, Ill., whose talking machine business has been steadily expanding throughout the country, was recently in New York on one of his periodical visits. Mr. Silverman is of a keen, analytical mind, and he has many constructive and advanced ideas regarding the talking machine business, particularly the sales end, which have proven of great interest and advantage to dealers handling the Mandel line.

GOOD SALESMANSHIP

It is not good salesmanship to sell a customer what she doesn't want—or can't use. It is not good advertising to sell goods by misrepresenting. Good salesmanship is making the customer realize the merchandise will add to comfort, or enjoyment, or convenience. Good advertising is telling the truth about goods so attractively that readers will feel the urge to buy.

LEGERDEMAIN and VICTOR SERVICE

D **W** **S**
I **T** **S** **O** **N** **E** **V** **I** **D** **E** **N** **T** **S** **E** **R** **V** **I** **C** **E**
 Evident.

DITSON'S

The Wartime Service

BOSTON

VICTOR EXCLUSIVELY

NEW YORK

Victrola IV, \$25
Oak

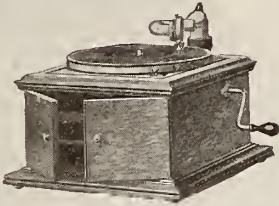

Victrola VIII, \$50
Oak



Victrola X, \$90
Mahogany or oak



**“Will there be a
Victrola in your home
this Christmas?”**

We do the questioning—in our advertising which reaches every part of the country.

People do the answering—by going to the stores of Victor retailers everywhere.

You do the business—demonstrate the Victrola and turn the prospect into a customer.

Victor Talking Machine Co.
Camden, N. J., U. S. A.

“Victrola” is the Registered Trade-mark of the Victor Talking Machine Company designating the products of this Company only.

Warning: The use of the word Victrola upon or in the promotion or sale of any other Talking Machine or Phonograph products is misleading and illegal.

Important Notice. Victor Records and Victor Machines are scientifically co-ordinated and synchronized in the processes of manufacture, and their use, one with the other, is absolutely essential to a perfect reproduction.

Victrola XVI, \$225
Victrola XVI, electric, \$282.50
Mahogany or oak



Victor Wholesalers

- Albany, N. Y....Gately-Haire Co., Inc.
- Atlanta, Ga.....Elyca-Austell Co.
Phillips & Crew Piano Co.
- Austin, Tex.....The Talking Machine Co., of
Texas.
- Baltimore, Md....Cohen & Hughes.
E. F. Droop & Sons Co.
H. R. Eisenbrandt Sons, Inc.
- Bangor, Me.....Andrews Music House Co.
- Birmingham, Ala.Talking Machine Co.
- Boston, Mass.....Oliver Ditson Co.
The Eastern Talking Machine
Co.
The M. Steinert & Sons Co.
- Brooklyn, N. Y...American Talking Mch. Co.
G. T. Williams.
- Buffalo, N. Y....W. D. & C. N. Andrews.
Neal, Clark & Neal Co.
- Burlington, Vt...American Phonograph Co.
- Butte, Mont.....Orton Bros.
- Chicago, Ill.....Lyon & Healy.
The Rudolph Wurlitzer Co.
Chicago Talking Machine Co.
- Cincinnati, O....The Rudolph Wurlitzer Co.
- Cleveland, O.....The W. H. Buescher & Sons
Co.
The Collister & Sayle Co.
The Eclipse Musical Co.
- Columbus, O.....The Perry B. Whitsit Co.
- Dallas, Tex.....Sanger Bros.
- Denver, Colo.....The Hext Music Co.
The Knight-Campbell Music
Co.

- Des Moines, Ia....Mickel Bros. Co.
- Detroit, Mich.....Grinnell Bros.
- Elmira, N. Y.....Elmira Arms Co.
- El Paso, Tex.....W. G. Walz Co.
- Honolulu, T. H....Bergstrom Music Co., Ltd.
- Houston, Tex.....Thos. Goggan & Bro.
- Indianapolis, Ind..Stewart Talking Machine Co.
- Jacksonville, Fla..Florida Talking Machine Co.
- Kansas City, Mo...J. W. Jenkins Sons Music Co.
Schmelzer Arms Co.
- Lincoln, Nebr....Ross P. Curtice Co.
- Little Rock, Ark..O. K. Houck Piano Co.
- Los Angeles, Cal..Sherman, Clay & Co.
- Memphis, Tenn....O. K. Houck Piano Co.
- Millwaukee, Wis...Bädger Talking Machine Co.
- Minneapolis, Minn.Beckwith, O'Neill Co.
- Mohile, Ala.....Wm. H. Reynolds.
- Montreal, Can....Berliner Gramophone Co.,
Ltd.
- Nashville, Tenn...O. K. Houck Piano Co.
- Newark, N. J.....Price Talking Machine Co.
- New Haven, Conn.The Horton-Gallo-Creamer Co.
- New Orleans, La...Philip Werlein, Ltd.
- New York, N. Y....Blackman Talking Mach. Co.
Emanuel Blout.
C. Bruno & Son, Inc.
I. Davega, Jr., Inc.
S. B. Davega Co.
Charles H. Ditson & Co.
Landy Bros., Inc.
New York Talking Mach. Co.
Ormes, Inc.
Silas E. Pearsall Co.

- Omaha, Nebr.....A. Hospe Co.
Mickel Bros. Co.
- Peoria, Ill.....Putnam-Page Co., Inc.
- Philadelphia, Pa..Louis Buehn Co., Inc.
C. J. Heppe.
The George D. Ornstein Co.
Penn Phonograph Co., Inc.
The Talking Machine Co.
H. A. Weymann & Son, Inc.
- Pittsburgh, Pa...W. F. Frederick Piano Co.
C. C. Mellor Co., Ltd.
Standard Talking Machine Co.
- Portland, Me.....Cressey & Allen, Inc.
- Portland, Ore....Sherman, Clay & Co.
- Providence, R. I...J. Samuels & Bro., Inc.
- Richmond, Va....The Corley Co., Inc.
W. D. Moses & Co.
- Rochester, N. Y...E. J. Chapman.
The Talking Machine Co.
- Salt Lake City, U.Consolidated Music Co.
The John Elliott Clark Co.
- San Antonio, Tex.Thos. Goggan & Bros.
- San Francisco, Cal.Sherman, Clay & Co.
- Seattle, Wash....Sherman, Clay & Co.
- Sioux Falls, S. D..Talking Machine Exchange.
- Spokane, Wash...Sherman, Clay & Co.
- St. Louis, Mo....Koerber-Brenner Music Co.
- St. Paul, Minn...W. J. Dyer & Bre.
- Syracuse, N. Y....W. D. Andrews Co.
- Toledo, O.....The Whitney & Currier Co.
- Washington, D. C.Cohen & Hughes.
E. F. Droop & Sons Co.
Robt. C. Rogers Co.

ALL RECORD CUSTOMERS ARE ALBUM CUSTOMERS



MAKING THEIR SELECTION

A Place for Every Record and Every Record in its Place

Albums are an **Indispensable Requisite** in the talking machine business and wherever records are sold. Practical and handy. Save time and records. A **profitable adjunct** to the business.

We manufacture disc Record Albums to fit cabinets of all sizes and styles. With the indexes they are a complete system for filing all disc records.

We have unexcelled manufacturing facilities, and considering quality our prices are the lowest. Write us, giving quantity you may desire, and we will quote prices.

OUR ALBUMS ARE MADE TO CONTAIN VICTOR, COLUMBIA, EDISON, PATHÉ AND ALL OTHER DISC RECORDS

NATIONAL PUBLISHING CO., 239 S. American St., PHILADELPHIA, PA.

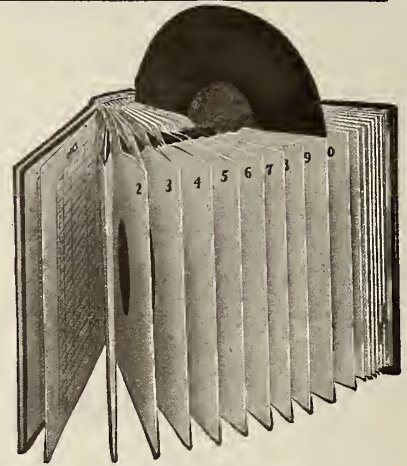

THE PERFECT PLAN

GENERAL PROSPERITY NOW REIGNING IN THE SOUTHEAST

Talking Machine Dealers in Atlanta and Vicinity Look for Heavy Business With More Liberal Supplies Available—Change in Control of Veteran House—Some Recent Happenings

ATLANTA, GA., December 8.—Dealers in talking machines in this city report a very satisfactory business for the month of November. While there is undoubtedly some curtailment in the volume of business on account of the shortage of goods in nearly all leading lines, there is still quite a large volume of business moving.

In general it can be said that the whole Southeast is in a most prosperous condition. While cotton planters and those closely connected therewith have made money this year, still Georgia, Alabama, Mississippi, and the Carolinas are not as dependent on cotton as they once were, and the diversification of crops has helped wonderfully. The city of Atlanta has made the most wonderful strides financially, having come from about seventeenth place in the weekly bank clearings during 1917 for the whole United States, to tenth place at present. The weekly clearings are now around \$75,000,000 and exceed such places as Cleveland, Minneapolis, Buffalo, Detroit and other cities of from two to three times the population.

It is regarded as probable that Camp Gordon, the local cantonment, will be continued as a permanent camp, and this will have a beneficial effect on all the territory near Atlanta.

The move to place all business, wholesale and retail, on a cash or nearly cash basis is being watched with interest by merchants and bankers all over the country. It seems passing strange that the South, the home of long-time credits, should become one of the leaders and pioneers in this movement.

The Atlanta Talking Machine Co., the oldest Columbia dealers in Atlanta, also Aeolian-Vocalion dealers, announce through Geo. P. Howard, owner of this business since 1915, that they have sold their stock and transferred their tenancy, good-will, etc., to other parties, who are abundantly able to continue the business, and no doubt will do a substantial volume.

Manager Salter, of the Victrola department of the Cable Piano Company, reports that they have had quite as large a volume of business as they could accommodate with their supply of goods. Their cash business, cash record trade,

first payments and monthly terms are in more satisfactory shape than ever before. They are expecting a very brisk winter and holiday trade. Mr. Salter reports that they have exceeded 1917 business in his department every month during 1918 except one, and the difference in this one month and that of 1917 was small.

Phillips & Crew Piano Co., the oldest Victor dealers in Georgia, report an active demand for all types of Victrolas, and the outlook to be exceedingly bright. They are fortunate in having set aside a certain portion of their jobbing stock for their retail demand, and are thus in good position to supply the local call for Victrolas and records.

The Haverty Furniture Co., Mr. Wilson, manager of the talking machine department, announces that E. E. Thornton, for the past two years in charge of their talking machine department, has resigned to go with the Columbia Co. as traveling salesman for the Atlanta branch. Mr. Wilson, his successor, was formerly with Phillips & Crew Piano Co., and is a thoroughly competent and able phonograph man. Everyone in the local trade wishes him well in his new position. The Haverty Co. report a large and increasing volume of business as each week passes. Their stores in Alabama, South Carolina, Tennessee, other Georgia cities and in Texas all say that their talking machine departments are doing nicely.

I. M. & R. D. Bame, Victor and Sonora dealers, are quoted as booking a substantial volume of business, and while they are, as are most dealers in standard lines, suffering somewhat from the difficulty in getting stock, they anticipate a large Christmas and winter trade. They are receiving more cash in first payments, cash sales and collections on installment accounts than at any time in the past.

The feature of the month was the advance in the price of the Columbia line on November 1, and the corresponding reduction about ten days later. This move is explained by the fact that the War Industries Board had ordered such a drastic reduction in the output of talking machines for 1919 that it was absolutely neces-

sary for even the largest manufacturers to advance prices in order to get the same profit as heretofore. The moment word was received that the Government would allow a considerably larger production than had been expected, this being as soon as the armistice was declared, the Columbia Co. set the figures back to the old prices.

The local Edison stores, Phonographs, Inc., and The Diamond Disc Shop are continuing a satisfactory and aggressive business. The new Edison has become well established here, and is very popular with people who appreciate "classy" goods. The Edison popular price record is now \$1.15 and those of higher prices have advanced proportionately.

Now that the war is at an end Phillips & Crew, Victor distributors in this city, are most optimistic regarding the business outlook. They feel that the Victor Co. will soon be able to make increased deliveries, and this, of course, will mean that the dealers in this territory will be better provided with stock.

The talking machine dealers and all interested in the industry in this city and section wish the proprietors of the Talking Machine World and all subscribers a Merry Christmas and a Happy New Year. Surely we all have more to be thankful over this year than at any time in this generation, the end of the Great War.

Don't judge a man's loyalty by his inability to sing the national anthem. Many a real patriot is tone-deaf!



Ideal for Holiday Sales

In that period of uncertainty as to what to give, show your customers the

CORTINA Phone-Method

Sell them the records, the talking machine and the text books. The Cortina Military French-English course is especially adapted for those going "over there."

Send for full information. Advertising matter and window displays.

The Cortina Academy
12 East 46th Street :: New York



Extends to the Trade Sincere
Wishes for a
**Merry Christmas
and a Happy New Year**



We are preparing for the biggest phonograph year in history, and expect to give our dealers maximum service in handling their album requirements

New York Album & Card Co., 23-25 Lispenard St., New York

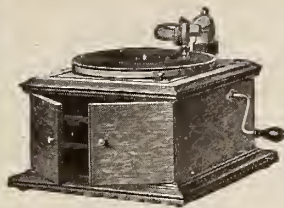

Victrola IV, \$25
Oak



Victrola VI, \$35
Mahogany or oak



Victrola VIII, \$50
Oak



Victrola IX, \$60
Mahogany or oak

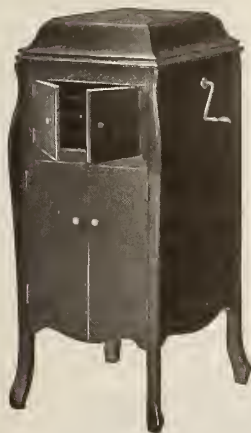

Victrola X, \$90
Mahogany or oak



Victrola XI, \$115
Mahogany or oak



Victrola XIV, \$175
Mahogany or oak



Victrola XVI, \$225
Victrola XVI, electric, \$282.50
Mahogany or oak



Victrola XVII, \$275
Victrola XVII, electric, \$332.50
Mahogany or oak

Victor Supremacy

The enormous public demand for the Victrola, the unparalleled success of Victor retailers everywhere unmistakably tell of Victor supremacy.

Victor Talking Machine Co.
Camden, N. J., U. S. A.

"Victrola" is the Registered Trade-mark of the Victor Talking Machine Company designating the products of this Company only.

Warning: The use of the word Victrola upon or in the promotion or sale of any other Talking Machine or Phonograph products is misleading and illegal

Important Notice. Victor Records and Victor Machines are scientifically co-ordinated and synchronized in the processes of manufacture, and their use, one with the other, is absolutely essential to a perfect reproduction.



The TALKING MACHINE WORLD

For the makers & sellers of talking machines

PUBLISHED BY EDWARD LYMAN BILL, Inc.

President and Treasurer, C. L. Bill, 373 Fourth Ave., New York; Vice-President, J. B. Spillane, 373 Fourth Ave., New York; Second Vice-President, J. Raymond Bill, 373 Fourth Ave., New York; Assistant Treasurer, Wm. A. Low.

J. B. SPILLANE, Editor

J. RAYMOND BILL, Associate Editor

Trade Representatives: B. BRITTAIN WILSON, L. M. ROBINSON, WILSON D. BUSH, C. CHACE, V. D. WALSH, E. B. MUNCH, L. E. BOWERS, A. J. NICKLIN

Boston: JOHN H. WILSON, 324 Washington Street

Chicago Office: E. P. VAN HARLINGEN, Republic Building, 209 South State Street. Telephone, Wahash 5774

London, Eng., Office: 2 Gresham Buildings, Basinghall St. W. LIONEL STURDY, Mgr. The Talking Machine World has regular correspondents located in all of the principal cities throughout America.

Published the 15th of every month at 373 Fourth Ave., New York.

SUBSCRIPTION (including postage): United States, Mexico, \$2.00 per Year; Canada, \$2.25; all other countries, \$3.75. Single copies, 25 cents.

ADVERTISEMENTS: \$4.50 per inch, single column, per insertion. On quarterly or yearly contracts a special discount is allowed. Advertising pages, \$125.00.

REMITTANCES should be made payable to Edward Lyman Bill, Inc., by check or Post Office Money Order.

NOTICE TO ADVERTISERS.—Advertising copy should reach this office by the first of each month. By following this rule clients will greatly facilitate work at the publication headquarters.

**Long Distance Telephones—Numbers 5982-5983 Madison Sq.
Cable Address: "Elbill," New York.**

NEW YORK, DECEMBER 15, 1918

THE end of the war has brought relief to the talking machine industry in more ways than one. Just as The World went to press last month there came the news of the lifting of certain restrictions regarding the use of metal in talking machine manufacture. Since then all restrictions covering curtailment of output, or priorities in steel supplies, have been removed. This removal of all restrictions has meant that manufacturers can now with perfect freedom carry on their business under normal, pre-war conditions, although, of course, there will exist for some time the question of sufficient labor and other problems that go with the period of readjustment and which affect other lines of industry.

The trade as a whole is to be congratulated on the manner in which it has withstood the stress of war and how the various factors have surmounted tremendous difficulties and kept things going even when the outlook was most unfavorable. The attitude taken toward the industry by the Government officials has been largely due to the educational campaign conducted by members of the trade showing the essentiality of music during wartime. The cries of the radicals and the unthinking that all industries not actually engaged in the making of war munitions or clothing, or in distributing food, should be eliminated for the period of the war, were fortunately not heeded, or even taken seriously in Washington. The curtailment of production in non-war industries was recognized as a matter of prime necessity, for the winning of the war was the nation's first business, but curtailment orders were issued only after careful investigation, and were designed to affect industries only to such an extent as was absolutely necessary in the view of the officials. The idea was not to cripple one industry at the expense of others, but endeavor so far as possible to allow all industries to carry on and keep going even though on a limited scale.

The importance of the talking machine in maintaining the morale of our fighting forces, as well as of the civilians at home, during the dark hours was fully recognized by both civilian and military authorities, and that had much to do with the consideration shown the industry, and the arguments presented by those elected to represent it in Washington. A number of plants as a patriotic duty turned a large percentage of their facilities over to direct war work, which was the proper thing. This fact, coupled with the observance of certain curtailment orders naturally reduced the output both of machines and records to a considerable degree, but the more serious curtailment orders that would have still further reduced the output of the manufacturers had hardly been promulgated before the sign-

ing of the armistice with Germany made possible their withdrawal.

The action of the Government officials in lifting restrictions at the first possible moment is to be accepted as an indication of the attitude of the Federal authorities toward industries generally, among them this of ours, and an indication of what may be expected in the matter of Government assistance during the reconstruction period.

FROM Washington comes the good news that the Senate Finance Committee in redrafting the War Revenue bill has fixed the war excise tax on talking machines and records at 5 per cent., as compared with the 10 per cent. tax provided for in the original House bill. This reduction in tax on talking machines follows the removal from the bill of the sections providing for a floor tax on talking machines and records, as well as other musical instruments in the hands of manufacturers, wholesalers and also retailers at the time the law became effective. As the measure now stands the manufacturer will be called upon to pay what means an actual increase of only 2 per cent. over the tax provided for in the existing law—a much more equitable increase than was originally proposed.

The various representatives of the industry have worked faithfully in Washington to bring about the reduction of the proposed tax on talking machines and records, emphasizing particularly the importance of those products to the nation, as a force for the building and maintenance of morale, and also pointed out that the 10 per cent. tax as originally proposed would prove ruinous to the trade as a whole. The Senate Finance Committee has finally accepted these arguments at their full worth, due perhaps in some measure to the change in the war situation, and the belief that the amount of revenue originally intended to be raised by the new bill will not be necessary.

Members of the trade, however, must still keep on their guard until such time as the new War Revenue bill in its final form and as agreed upon by both the House and the Senate reaches the President for his signature. It is still possible, although not at all probable, that the bill may again be changed perhaps to the disadvantage of the industry, and this possibility must be guarded against.

The elimination of the floor tax represents a genuine victory, for it has been frequently stated that a goodly number of dealers who have gathered together substantial stocks of machines, and particularly records, as a matter of precaution, straining their resources to finance the purchase of stock, would be unable to meet the Government's demands for the payment of 10 per cent. tax over and above the purchase price of the goods. It is doubtful if any attempt to reinsert the floor tax provision, or a similar tax, will be made in the final draft of the bill.

SALESMEN often overlook opportunities not only to secure new prospects, but to develop their business along new and profitable lines by failing to call upon customers to whom they have sold talking machines and records. In normal times, of course, this would be to some extent impossible, but in these war days, when a shortage of certain types of talking machines is prevalent, and there is a little time to spare, advantage should be taken of this condition by dealers and salesmen to visit owners of talking machines, and ascertain whether the machines and records purchased are giving satisfaction—in other words, seek to find out what might be done to further enhance the pleasant relations that should exist between the dealer and the customer.

This display of interest on the part of the salesman, or the dealer, is certain to bring its reward in the near future, when sufficient stock is procurable, and when trade will be resumed in a vigorous way. It is a move that will result not only in friendships, but in sales. For the man or house who puts into force this policy of "service" is destined to have news of his good will and service progress spread broadcast among relatives and friends of those called upon, with the result that as a purely advertising proposition it will be found profitable as well as business of the most approved kind.

THE great world war with its heavy drain upon the resources of this country, and for that matter upon practically all the countries of the world, in the matter of men and material, is now at an end, and with the coming of victory there comes also the period of reconstruction—of readjustment, as it is more popularly termed, and the problems that arise in connection therewith.

These problems will necessarily affect business men in all lines with the gradual return from war to peace pursuits. The reallocations of hundreds of thousands of skilled and unskilled workers; the replacing in the industrial field of some hundreds of thousands of erstwhile soldiers and sailors, and the turning of great industries now engaged in war work over to the manufacture of peacetime merchandise, cannot be done offhand or hurriedly without creating the danger of a crisis of some sort.

There will be some scurrying, of course, to get back to normal, or as close to normal as possible. Those who have had their businesses curtailed or partly eliminated are going to expand, or try to expand, and resume their pre-war status. They are going to try to make overnight work of a two-year task, and it is going to be a difficult achievement—one in which the weakling has a small chance of success. How are the talking machine manufacturers, wholesalers and retailers going to fit into the scheme of things when this adjustment is going on?

The time to plan and the time to work is not after peace is formally declared at the international conclave, but right now, so that plans will have been prepared and the foundation will have been laid along proper lines when the thoughts and activities of the nation are fully turned to peace channels.

The concern, whether engaged in manufacturing, wholesaling or retailing, that has kept its name before the trade and the public constantly during the war period, and continues the same policy, perhaps on a bigger scale, for the coming months, is going to be in a position to jump ahead of competitors who have not been so farsighted. The constant advertising may not have produced tangible results in full measure, but it has nevertheless served to mould opinion, to impress the name of the company and the product upon those who will be in a position to go out and buy. It is going to help that concern garner business while the fellow who has laid down is scratching around to get acquainted again, for it will be discovered that rebuilding a business is as hard, if not harder, than establishing a new business. It is a little point worth thinking over.

Then comes the biggest and most important question of them all—the question of credit. During the period of the war there have been many manufacturers and retailers who have absolutely forced a rearrangement of the credit system, and terms, both wholesale and retail, have been shortened materially in many cases. After the war neither manufacturers nor retailers can go back to the old system, and the ones who do are lost. The period of readjustment—of reconstruction—is more than likely to be also a period of financial adjustment. The high wages of to-day are going to become a thing of the past, particularly as they affect war workers. Men must seek new fields and at the same time accept less compensation. This is going to have a decided effect on the general financial situation.

Then there comes the redistribution of capital, the return of billions from war plants into the normal channels of business. That

in itself is going to have its effect on the money market. It means that the credit obtainable either by the manufacturer or retailer is going to be limited, possibly just as limited as it is to-day. It means that both divisions of the trade must be able to finance themselves to a great degree, and to finance themselves means to get cash, or what approximates cash, for the goods they sell.

Without doubt the loosening up of the material market will bring with it a reduction in manufacturing costs and a subsequent reduction in the price of manufactured products. So much the better from the selling viewpoint, for more reasonable prices will mean a broader field of distribution.

There will be many material benefits to business as a result of the end of the war, aside from the victory which we have achieved. Let the trade hold on to a sound credit system as representing one of these lasting benefits.

THERE ought to be no more doubt as to a business man's duty when he hears false business doctrines presented than there is about the physician's duty when he hears a man putting false notions into the minds of the untutored regarding, we will say, the germ theory of disease.

Everybody is interested in business, and, if they only knew it, not simply in the innumerable details which enter into business transactions, but in the principles which underlie these transactions, principles which the vast number have no grasp of.

Our time is so mortgaged to the succession of events that we fail to realize what significance there is in them, with the result that when things go wrong we make a hit and miss guess at the cause and probably lay the blame on some incident having no more relation to the wrong results than gold buried 400 fathoms under the sea has to the high cost of living.

Every decision in business based upon prejudice is helping to build up the mountain of obstacles in the progress of business toward a stable position. Therefore is it not the duty of business men to shake men out of their prejudices, not roughly, nor with that air of superiority which always defeats good purposes, but perhaps humorously, always good-naturedly, through that power of persuasion which comes by studying men's whims?

Many are all the while letting slip the opportunity to give a new or wider vision. In other words, to lead the men prejudiced by narrow outlook into a rational view. If a man has a lazy streak in him, the temptation is to let the fellow with the false notions wallow in them. Sometimes life is too short to put reason into him, but the lazy streak tempts some into this thought too frequently, and if we were perfectly frank it would be admitted that it was sheer laziness which decided many against action.

Cultivate the fine art of persuasion. There is no art finer or, in the hands of a rational man, better calculated to get the affairs of business on a sound, progressive basis.



A Merry Christmas

- to our Brave Boys who made even Germany unhealthy for the world's human cootie.
- to Pearsall Dealers who have had a successful year regardless of drawbacks.
- and to those dealers who will use Pearsall Service for the first time in 1919—the Pearsall Kid.

Silas E. Pearsall Co.

Wholesale Distributors of Victrolas and Records

10 East 39th Street

NEW YORK

Starr Policy for 1919

The Starr Piano Company announces herewith its policy for 1919.

Prices will be restored at once to the figures which prevailed before Starr production was restricted by governmental order.

Decreased output resulting from governmental curtailment necessitated an increase of price on all Starr models of pianos, player-pianos, grands and phonographs. This increased price is now removed on the entire Starr line, readjusted prices to be in effect as of 12 o'clock midnight Tuesday, December 31, 1918.

It must be remembered that The Starr Piano Company has been on an exclusive war basis. Deliveries will naturally be increased as the factory is being restored to a peace footing. The respect in which The Starr Piano Company is held the world over has been greatly emphasized by its splendid performance in war service and by its products being exclusively adopted as standard for the U. S. Army observation balloons.

The capacity of the Starr factories has always been swiftly absorbed, but in view of the facts cited above, together with the introduction of the improvements devised by our experimental department in the last eighteen months, prospective buyers will do well to be forewarned against a demand without precedent.

We assume that peace will shortly follow the signed armistice. In that event the entire capacity of our factory will be devoted to the production of Starr-made pianos, player-pianos, grands and phonographs.

In spite of that fact, we do not believe it will be possible to build during 1919 all the Starr products the world will want.

The Starr Piano Co.

Richmond, Ind.

“A Joy too Deep for Words” —but music can express it. These are joyful days—and music plays its proper part.

**Columbia Graphophone Co.
NEW YORK**



GREAT EDUCATIONAL CAMPAIGN

Princess Watahwaso Gives Concerts Under the Auspices of Educational Department of Putnam-Page Co. for Purpose of Creating Money Surplus to Buy Victrolas and Records

In a letter from Putnam-Page Co., of Peoria, Ill., they write of the successful work of Princess Watahwaso in connection with their educational department. In a tour of three weeks afternoon and evening concerts were given in cities of Illinois and Iowa and always to capacity houses. It was interesting to see 2,000 children sit for an hour listening intently and enjoying every minute, and in response to their enthusiastic applause number after number was repeated, to their great delight. It was an event



Listening to Princess Watahwaso

in their lives never to be forgotten, for a real Indian Princess told them fascinating stories of the forest, sang for them the songs little Indians sing and danced the ceremonial dances of her tribe. A truly wonderful day for them and Princess Watahwaso enjoyed it quite as much as they.

Great interest was manifested by both teachers and pupils and their co-operation was all that could be desired. The concerts were given under the direction of the music department in each city, assisted by the local Victor dealer, and both should be justly proud of their work. Too much cannot be said in praise of their effort, interest, co-operation and management. Assisting them were the teachers and pupils of the entire school force. Such a combination insures success! The proceeds were placed in the hands of the dealer, at the disposal of the teachers to be used for Victor educational records and school machines, the records selected to be suggested by a committee consisting of the supervisor of music and several teachers appointed by her.

In deciding upon Princess Watahwaso for this work the Putnam-Page Co. had the desirable combination of one interesting in an educational sense, a soloist of ability and great personal charm; instructing and giving a most unusual entertainment. They feel they were very fortunate in having Princess Watahwaso with them for this work. Everyone was delighted—felt repaid for their efforts and would like a return date at some future time. Princess

Watahwaso feels it a great privilege to give to the world the songs of the Indian and to help the pupils know their customs, traditions and legends, which in this day of modern civilization she regrets to say are fast disappearing.

Her program included songs collected and harmonized by Thurlow Lieurance. Among them “By Weeping Waters,” “Waters of Minnetonka,” “Sioux Serenade,” etc. These songs

have been recorded by the Victor Talking Machine Co. and are now in great demand everywhere.

Victor dealers are enthusiastic over the results of the concert and the Putnam-Page Co. is now planning to further assist its dealers in making definite the work in the schools—a feature of the work which should not be neglected in the educational department.

HOW HANDSHAKING CAN BE MADE TO HELP SALESMANSHIP

The Art of Shaking Hands Properly and at the Right Time Worthy of More Than Casual Study —Practice Appeals Differently to Various Classes of Customers

Shaking hands with customers often helps to develop in them a friendly attitude. It has a tendency to bring seller and buyer closer together. It is a good plan, however, to shake hands only with people who will be favorably affected by the action. Now and then a patron or a prospect comes around who is sort of offish or uppish or crusty or crabbed, and such a person needs to be handled at arm's length and no attempts made at familiarity. If the customer is not going to come half way on the hand shake pass it up.

Of course everything is going to depend upon the way you shake hands. If you merely stick out a limp paw for the other fellow to waggle up and down, you can't expect him to enjoy it very much.

First, learn how to shake hands. Learn the happy medium between the college freshman wrench and the lifeless cemetery flop. Shake hands quickly, firmly, as if you meant it. Shake hands as you know or imagine a man like Theodore Roosevelt would do it—with a hearty grip and a look in the eyes, not a limp wiggle and a glance at the other man's necktie. And don't hang onto the other's hand—whether man or woman. Shake it and be done.

Then, learn when to shake hands. Don't crowd the act upon the unwilling. Don't put out your hand and hold it there until the other fellow is shamed into taking it. Shake hands as if it were the natural thing for both of you to do. If you shake hands when you greet a customer, don't offer your hand again when you part a few minutes later. If the prospective customer is met as a stranger, leave the handshaking until you part, unless it is expected at

the outset. Make the action an indication of an acquaintance that has advanced during your meeting. Handshaking will help salesmanship if you use it in the right way.

TRIBUTE TO MEMORY OF T. T. GELDER

The National Publishing Co., manufacturers of talking machine record albums, Philadelphia, Pa., have just sent out a very gracious tribute to the passing of Tolman T. Gelder, who died suddenly some time since while on a visit to St. Louis. Mr. Gelder joined the forces of the National Publishing Co. November 4, 1899, and it is pointed out that during his nineteen years with them he proved himself of marked ability. Being a true and square man, his friends could be numbered by the hundreds. He was a great thinker and possessed an unusual reasoning faculty. He had most excellent judgment in sizing up a business situation. Mr. Gelder was held in high esteem by all who knew him, and his passing is greatly regretted.

PAYS TO TURN OVER STOCK QUICKLY

It is the man who turns his stock over quickly and often who makes the successful merchant, but to do this the credit end of his business must be well taken care of. Wisely made credits mean prompt collections, and prompt collections mean that cash is always ready without borrowing to start the cycle of purchases for another quick turnover. Good credits and prompt collections also mean the golden profit of cash discount, the basis every profitable business must be on.

Style 900

THE REGINAPHONE

A phonograph of the highest grade with many exclusive features. The new Regina Sound-box is the greatest improvement in talking machines in years, reproducing all hill and dale and lateral cut records equally well, and in a manner unsurpassed.

New Regina Sound-Box

Territory arrangements with active dealers. Send for particulars.

THE REGINA CO.

47 West 34th Street, NEW YORK
209 S. Wabash Ave., CHICAGO, ILL.

Manufacturers of the Regina Music Box and other musical instruments for over 25 years.

"The Day" HAS COME

*Thank God, the War
is over—including
the shouting.*

But during the period of reconstruction and readjustment the man of vision foresees events that cast their shadows before them.

For instance, he sees that it will be many a day before the Steel Needle business will again be normal—that everything that has to do with the manufacture of needles, including American Labor, is not going down in price—that the demand for High Quality Steel Needles for at least the next few years is going to be enormous.

The entire world for more than four years has been living a life without gaiety. This same world now wants to feel the full enjoyment that music will give them. Hundreds of thousands of new marriages will take place. These new homes will want music. Every home in which there will be a Talking Machine will need an endless supply of Steel Needles.

The market is practically oversold today. What it will be a month, three months or a year from now, is for you to judge. Some dealers will be in a position to supply their customers with Steel Needles.

As a dealer with foresight, we advise that you immediately anticipate your next years requirements

Made in America by Americans

BRILLIANTONE STEEL NEEDLE CO. OF AMERICA
INCORPORATED

Suite 657-659, Marbridge Building, Broadway at 34th Street, NEW YORK CITY

B. R. FORSTER, President

Pacific Coast District
WALTER S. GRAY
530 Chronicle Bldg.
San Francisco, Cal.



Developing a Retail Talking Machine Business Along Practical Lines

By Warfield Webb

Dealers who fail to realize the importance of combating competition with practical plans and clever ideas often wonder why others make a success that is worth while, and they only eke out a fair living. What they lack in their ideas of salesmanship are practical suggestions to the trade. They fail to arouse that keen interest that is the best possible argument for making sales to customers who come again.

A study of the successful dealers in talking machines and records proves that the men or concerns who have made a striking advance have done so from the very fact that they proved themselves to be men with ideas that were of value. Competition is a vital factor to-day in the talking machine industry. This single item has done more to develop the sale of these machines—the records follow as a natural consequence—than many of the after-effects and the plans that have been laid for the betterment of business. The dealer who does not fully value this part of his industry is overlooking a very significant element. It is doubtful, in fact, if he ever makes good.

In coping with this matter of competition what can the dealer do to offset it? What can he plan in the method of his sales or in the display of his stock or in the publicity ideas that he evolves, that will prove that he is a live man? Theories are of little value in a case of this kind. What is demanded now are facts. He must adhere to helps that will induce the public to seek him, and this can only be done in a profitable way by making his place of business a magnet. The people are not coming to him from sentiment altogether. But this, too, will prove a help when rightly distributed.

Practical helps are made up of displays, both in the windows and in the sales section. Care in arranging the stock. Rapidity with which the machines can be shown and a careful knowledge in the placing of the records. There must be a reason why the trade will seek you when other concerns are not overlooking the need for giving the trade all that that service implies. Poor displays are not going to help you. Lack of some practical sales system in giving your customers what they want quickly is not going to encourage them to buy now or to come back later. They are after that quality of service that is the ready-to-see brand.

Now what is your live competitor doing to increase his sales? What has been the reason for his success? Go to his store and ascertain. How? Will you ask him to explain this to you? No. If you did he would refuse you. You must find out for yourself. This is sometimes an easy matter and at others it is a difficult one. But you can ascertain some things by painstaking observation. However, as imitation is a very bad quality of flattery, you will doubtless refuse to play the second part in this sales game.

Then you will be compelled to modify his plans and to improve upon them if you can, and therein lies the secret that will be your most logical argument for better sales. The best way to prove that you are a capable man is to take a careful inspection of yourself. Begin with your individual self. Go over your own ideas of salesmanship, of display, of stock and of customer reception. Then make a note of the value of your employes. What percentage of them are making good? Have you watched their sales plans and have you noted the reason as to why sales were often lacking?

Perhaps they have been lacking on account of their inability to make good. They were ignorant of the first qualifications of salesmanship. They did not know how to receive a customer intelligently. This is not to be wondered at. There are a great many inferior salespeople. Cheap help, while not always a drawback, is likely to be an asset to your competitor.

He might become aware of this, for people are going to comment at times, you know, of things that do not directly concern them.

It may be that your stock is lacking in the number and character of the machines offered or in the records shown. This is sure to create unfavorable comment, and when the public becomes aware that you are a failure in this way they are not going to give you very much consideration. In buying records, particularly, they want to have the pleasure of making a selection from a number of pieces. They want to be

*Development Work
Cannot be Carried
on Successfully in
Haphazard Manner*

given a practical demonstration of your ability to show them that you have the stock to meet their whims.

You may think that this is a foolish idea. It is, if we look at it in one way. But we must look at it in a broad way and cater to the public's whims. The same rule applies to the editor of a magazine. He must give his readers something that will please them regardless of what his personal opinion might be. The practical dealer is a man who caters to the public taste. He forgets his own ideas and tastes. He is seeking to sell the public, and he stands ready to combat competition with this striking argument.

The live dealer values this to the limit. He does not permit his tastes to interfere with the public's and he pleases them by this large idea. It is a practical one. He serves them with that care that is an insurance that they can get

what is wanted. They may be selfish, and they may be exacting and they may prove to be annoying at times. The dealer who is keen to these notions overlooks them. The important part that he sees is in making the customer a satisfied one. He will pass up his own ideas when he finds that they are incompatible with the customer's.

What is competition doing for you that you cannot make capital of? What is that live dealer over the way doing now that makes his trade so good? Well, he does advertise. Yes, and he backs up his publicity statements with facts. Otherwise his advertising is a deception and the public is not going to be deceived for very long. But he makes good because he proves that he is a practical dealer. That is the sum total of what this means.

His window displays are attractive. They prove that he is fully alive to the needs of the public. They are in touch with anything that is the order of the day. It might be a national celebration or it might be a local affair. It might be an opera celebrity or a musical artist who is to give a recital in his city. He makes this one feature a practical help to the customers. If there is a popular song or a hit in the musical world he places these records in the forefront. It proves to the public that he is a man who is in touch with the world, and that it is to their interests to deal with a man of this type.

How are you a practical dealer? Are your ideas based on a foundation that does inspire the public with the belief that you are a capable dealer? If your competition is keen well and good, you have a stronger reason then to work all the harder that your store will become the trade mecca of your locality.

IMPORTANCE OF PROMPT PAYMENTS

When a customer begins to be slow in his payments, then look out for scattered purchasing. The experienced credit man does not need to be told that big permanent relationship between creditor and debtor will come generally only through insistence upon recognition of terms of sale and promptness in meeting them.

*Announcing the
removal of*

The DOMESTIC
Talking Machine
Corporation to

L A T R O B E
P E N N S Y L V A N I A

“Domestic” on talking machines stands for the highest quality of product at the retail prices of \$17 to \$135.

Three Big Values—Three Big Sellers

Model No. 3
\$125.00



Model No. 6
\$90.00



Model No. 5.
\$75.00



MANDEL PHONOGRAPHS—made by one maker—backed to the limit by the manufacturer, mean a service that guarantees your success.

The MANDEL embodies massiveness in cabinet design, efficiency in mechanical construction and richness in tonal quality. These three factors are the making of a good talking machine. And the MANDEL is a good machine.

The three models here illustrated are producing big results for MANDEL dealers. Three popular-priced phonographs—each model giving the consumer greater value for his money than he could ordinarily obtain.

And to the dealer we offer a wonderfully attractive proposition—a co-operative plan that makes it pay him to sell MANDEL Phonographs.

Write for full details—today

A Letter from Missouri—Name and Address on Request

MANDEL MFG. CO.,
Chicago, Ill.

Gentlemen:

Please book my order for immediate shipment by freight, the following:

Two Style No. 3 MANDEL Phonographs, Oak finish.

Two Style No. 3 MANDEL Phonographs, Mahogany finish.

Each purchaser of the MANDEL is delighted with the rich tone value and each sale draws more sales. I sold the last MANDEL today, so please rush out this shipment. I want to keep the MANDEL on my floor. (A MANDEL DEALER)

**MANDEL
MANUFACTURING CO.**

501-511 So. Laflin Street, Chicago, Illinois

Getting After The Talking Machine Trade of The Returning Soldiers

By Courtenay Harrison

Many talking machine dealers have been using in their advertising the slogan, "Keep the Home Fires Burning—with a talking machine by the fireside to play the tunes that your boy loves to hear on the battlefield across the sea." This was good business, and it helped to sell some machines.

Now, however, that the boys have put over the job laid out for them and are about ready to return to their homes in America, the slogan quoted above is out-of-date. The thing for the talking machine dealer to do now is to advertise AT the soldier boys instead of ABOUT THEM.

This brings us down to the main point of this article—that the talking machine business is going to be unusually good from now on, and returning soldiers are going to be among the best purchasers. This is true for a good many reasons.

In the first place, it is generally agreed that out of the melting pot of our army organization will come an army of civilian-idealists. Men who were poolroom loafers on one extreme and men who were society-idlers on the other extreme are coming back from Europe with a new conception of what constitutes a happy existence. They are going to want to get to work doing something useful. They will get married, build homes for themselves and they will want to stay in these homes. This is not a mere prophecy by one individual. The greatest thinkers and students of economy in the country say that such a condition will prevail.

With the desire for a home comes the desire for the things that make home life really worth while. Music is one of them, it is an essential, and the soldiers have learned to appreciate this fact. Many of them, yes thousands of them, listened to talking machines when in from the front line for a rest, and learned for the first time how cheering good music can be, what a source of inspiration it is. These men will all want a talking machine in their homes, and if the dealer advertises to them in the right way selling them will be an easy task. Besides the unmarried men who will come back and take wives and build homes, there are thousands of others who will be talking machine prospects when they get back into civilian life. These last mentioned are the soldiers who married on

the eve of departure for the front, and who will set up homes of their own as soon as they return. They, too, will have learned that a home is not complete without a talking machine.

Naturally soldiers who have been over there fighting for their country will feel a pride in their achievement, and will be interested for a long time in anything that calls to mind their fight on the other side. For this reason the best kind of advertising to get the business of the returned soldiers will naturally be advertising that refers to their life as soldiers. The

*Now is the Time
to Advertise to
Soldier Boys In-
stead of at Them*

idea here is the same as that used for advertising to the parents of the boys while the war was on. Everyone is familiar by this time with the way in which thousands of ads coupled up selling goods with winning the war.

The thing to do now is to couple up the peace era with renewed activity in selling. Headlines like this would be good for advertising talking machines to soldiers: "The songs you heard over there can be heard in your home over here, on the Blank talking machine; start your home right; put music there the first thing"; then give terms, etc. Or: "You remember how much fun you got out of that talking machine in the Y hut in France; come to us, and let us tell you how you can have an instrument in your own homes on easy terms." These two suggestions are just to give the idea. Any dealer who is awake can frame up attractive ads that will get the attention of soldiers starting new homes as they get back into civilian life.

Some dealers may contend that not enough

soldiers will be released in his town to make such advertising pay. Many thousands of soldiers will be released each month from now on, from all sections of the country. Some of them in your town are bound to respond to the kind of advertising mentioned. Besides, such advertising will be read by others than soldiers, because it will appeal to the popular taste, and hence it will sell machines to many persons not soldiers. It's good publicity.

Such ads as those mentioned can appear over a period of several months from the present time on. The soldiers will not all be back for at least a year, or two years, perhaps.

Speaking of soldiers being good purchasers, there is another thing in this connection to remember, and that is that soldier-civilians will be good "risks." They have learned the value of economy and have been taught discipline and a sense of duty which will make them desire to meet their obligations promptly.

It has been stated that the soldiers will not be the only ones to whom the kind of advertising spoken of will appeal. Another class that will read these ads and buy talking machines is the Liberty Bond holders. During the war it was patriotic to hold on to bonds, but now that the war is won many people who have wanted things like talking machines, but who never could save up enough to buy them, may be inclined to dispose of their Liberty Bonds and purchase things for their pleasure that they have long wanted. A different "twist" can be given to advertising to cover appeals to this class.

All things considered, it looks as if the dealer in talking machines had the greatest opportunity ever to "do business" for the next year or so with so many new homes being started. If he is alive, advertises in the right way, and gives his prospects the proper attention, he simply can't help getting the business. It's here, and the live dealer will get it.

INCORPORATED

Among the incorporations filed with the Secretary of the State at Albany, N. Y., recently was that of the Emerson Record Sales Co., Manhattan, with a capital of \$25,000, by E. Ennisson, H. T. Leming and V. H. Emerson.

Don't Lose the Business Momentum

*It's Harder to Start and Gain Speed Than
It Is to Keep Going—Don't Put on the Brakes*

We are putting forth every effort to back up our dealers, not only with available stock, but with sales promotion material and exploitation plans that will keep the pep in their business until conditions become fully normal.

Our Business Now—and Always—Is to Help as Well as Wholesale

ECLIPSE MUSICAL CO.
Victor Distributors CLEVELAND, OHIO

ECLIPSE

Columbia Grafonola

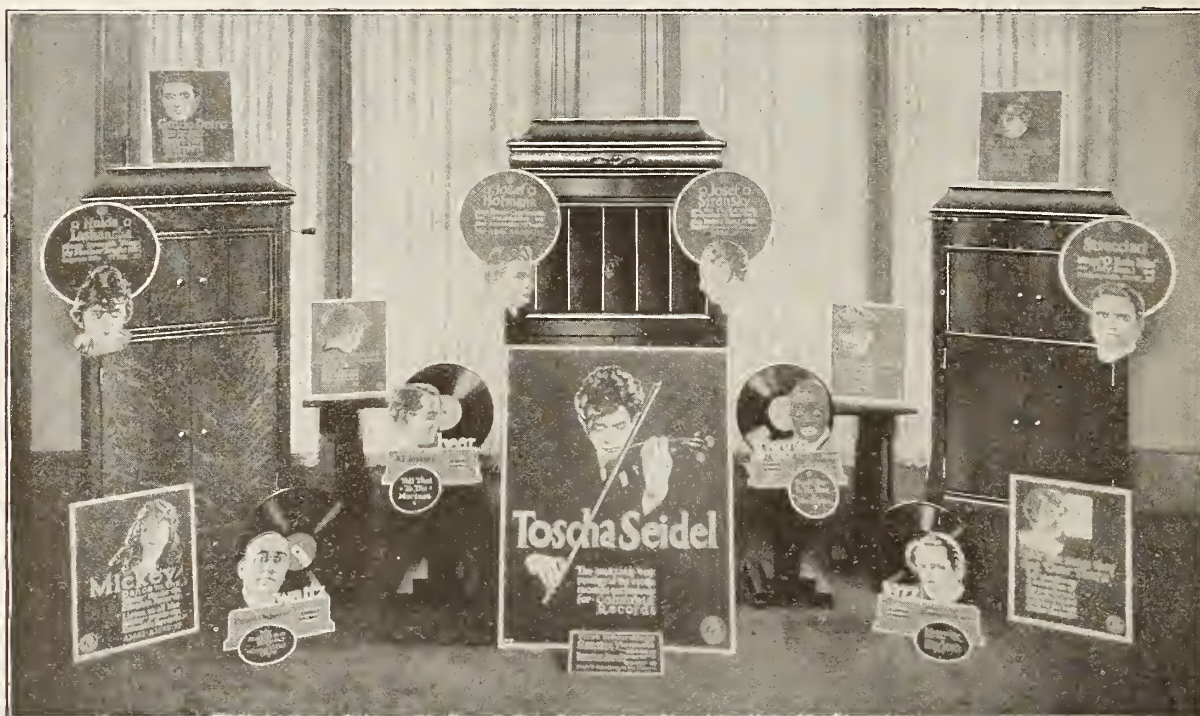

Columbia Dealers Get This January Window Display

We've sent this big January Window Display to Columbia Dealers throughout the United States.

Use it—now! and make your windows work overtime.

The new Columbia Record List is one of the finest we've ever made up. The records fairly sell themselves. Give them a chance—show them!

*This is a good time to feature Foreign Language Records.
Why not put in a line? The cost is small—profits big.
Write for particulars. 102 West 38th St., New York City.*



COLUMBIA GRAPHOPHONE COMPANY

NEW YORK

Columbia Grafonola

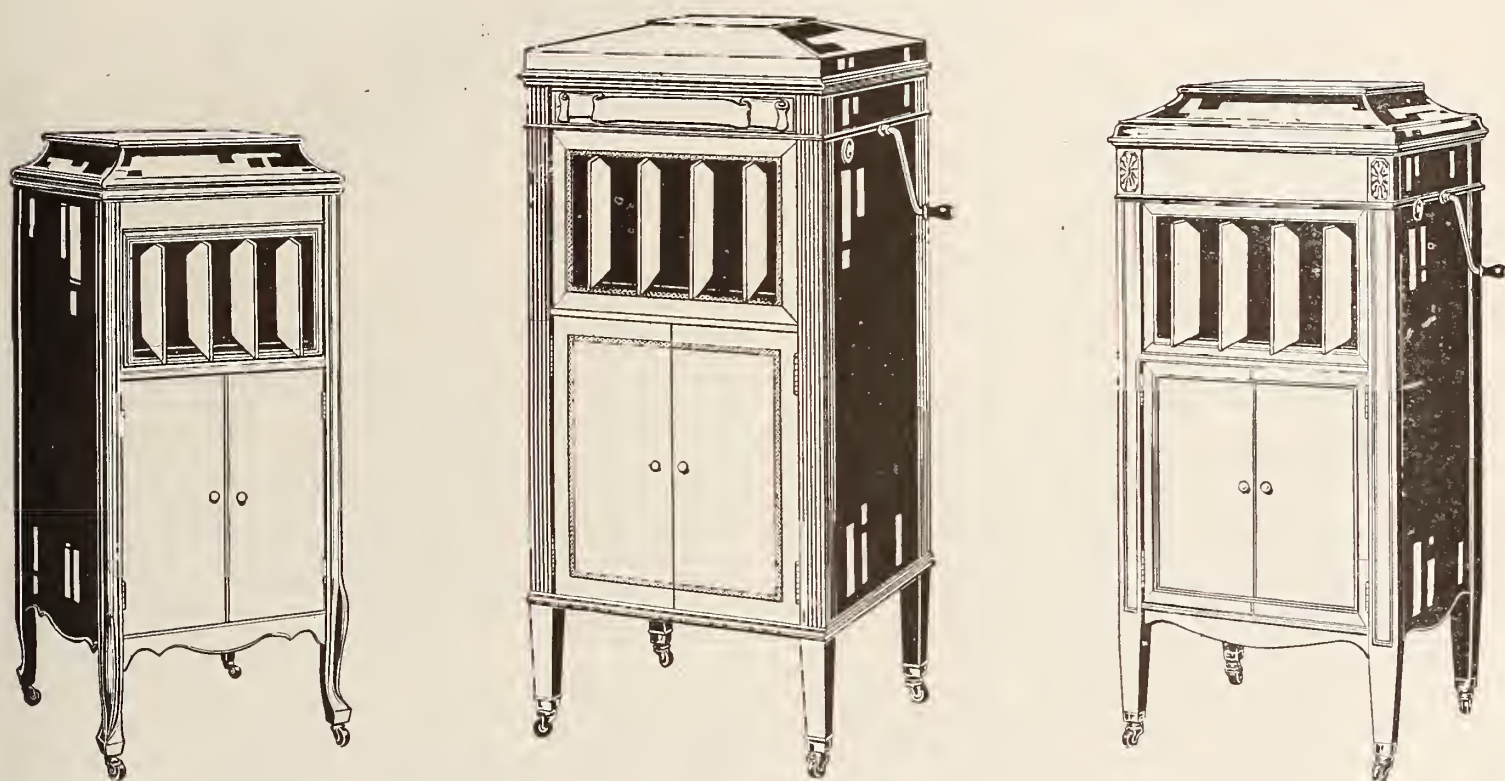

Make This Your Biggest Year!

The war is over. After years of retrenchment and "doing without" the world is swinging back to the piping times of peace.

People want relaxation, amusement. And the New Year is here! Never was there such a combination for good phonograph business.

If Grafonolas were essential in war-time, how much greater is their need in the joyful celebrations of peace. Now is the time for folks to buy that Grafonola they meant to get "when the war ends."

Make this the biggest year ever.

If we can help you with special advertising material, sales suggestions, etc., let us know—quick.

COLUMBIA GRAPHOPHONE COMPANY

NEW YORK



Explaining the Value of Veneered Cabinet Work to the Talking Machine Customer

Although veneer is now used on practically all cabinet work, and the solid mahogany, or walnut, of other days has practically disappeared, the average talking machine salesman should use great care in appraising customers of the fact that the case, or other part of the instrument, is built up of veneer, and avoid having the question as to wood construction put to him if possible. Those who are acquainted with modern woodworking methods appreciate the fact that a veneered cabinet properly made is generally stronger and more to be desired than one of solid wood. There are still people, however, who believe that to describe a piece of furniture, or a talking machine cabinet, as mahogany, is to imply that it is built of solid wood, and accept any instrument that is veneered as a confession of guilt in the matter of trying to deceive the buyer.

When the salesman is called upon to state that a case is veneered he should not stop until he has shown to the customer just what advantage built-up veneer possesses. Arguments made in favor of veneer work that the salesman may do well to study have been set forth ably by C. D. Crain, Jr., in an article that appeared recently in "Veneers." "The fact that veneered rather than solid work is used throughout high-grade cabinets suggests some interesting lines of thought," says this writer. "Of course, the same general considerations which have led to the bulk of the furniture output being of glued-up stock apply to the manufacture of cabinets for talking machines; that is, permanence, strength and attractiveness of appearance, which are to be secured by this means, make it a logical thing to specify laminated woods. The cabinet is a piece of furniture just as much as it is a musical instrument, and its possibilities from the standpoint of beauty are such as to warrant the manufacturer in taking advantage of the attractive features of veneered work.

"In the larger cases, the broad surfaces which are exposed give a splendid opportunity for the use of handsomely-figured woods, and mahogany and oak veneers of exceedingly attractive appearance are regularly used. Walnut and figured gum are coming to the fore in some

of the cabinets, and before the war Circassian walnut was largely employed; but up to the present the greatest emphasis appears to have been put on mahogany, with oak coming next. In view of the desire of the manufacturer to have a case that is attractive to the eye, it is not anything to be wondered at that veneered work has been used.

"The thing that is worth pondering, however, is the undoubted fact that better effects, musically, can be secured by the use of veneered work than if solid material were employed. There seems to be no doubt that this is the case, and, in fact, it is an assumption that is generally found to exist in the talking machine trade; the reasons for this are not generally understood, however, and it does not appear that much effort has been made to analyze the situation from this standpoint, though undoubtedly the engineers of the big companies have made complete studies of the subject. That these concerns continue to buy panels for their cabinets indicates that their results have not been unfavorable to veneered work.

"Ever since the beginning of musical inclinations on the part of human beings wood sounding boards have played a part. The rudest instruments—of which the now famous ukulele of the Hawaiians is an excellent example—have sounding spaces enclosed by light pieces of wood. The reason for this is to enable vibrations, which cause sound, to be carried most readily. The heavier the wood, the more difficult it is to cause it to vibrate, of course; while in the case of metal the vibration is likely not to be of a musical quality.

"It is therefore reasonable to suppose that the musical quality of a phonograph would be increased just to the extent to which the responsiveness of the cabinet to the musical vibrations is developed. If the cabinet were made, for example, of inch boards, it would be difficult to use it as a medium for the production of sound.

The actual problem, as far as the sounding chamber of the phonograph is concerned, is to make it immediately responsive to the vibrations set up by the mechanism, so that they

may be transmitted to the exterior with the proper tone.

"It is the wood which is responsible for the tone, and the difference in quality between one phonograph and another, just as in the case of violins, is a difference in tone quality. While the mechanical features of the machines are credited by the manufacturers with responsibility for this difference, it is really the result of the manner in which the sounding chamber has been constructed. The constant experiments which have been made by the manufacturers along this line show clearly how the importance of this feature of the talking machine is appreciated.

"The difference has come about because instead of sending the sound through a tin horn, it is now brought out through a wood sounding chamber. This chamber is enclosed with light, veneered sides and top, and the material is so responsive to the vibrations introduced into it that a mellow, rich tone is developed, just as a beautiful tone is brought out of a fine violin. The fact that built-up material is employed enables lighter material to be used than would be possible otherwise, and as suggested above the lightness of the material is what makes it responsive.

"Sound waves are created by molecular vibrations, and it is easy to understand why heavy bodies are not easily set to vibrating and why light materials are employed in all stringed instruments where sound reproduction is involved. It is true that other considerations are passed on here, such as the weight of the instrument, but the reason thin wood is employed in stringed instruments is the same reason back of the use of laminated woods in talking machines—greater ease in securing musical vibrations.

"Since musical tone demands mathematical accuracy of the parts, it is also highly important that every feature of the instrument be true as to line and dimension. This would not seem to be so important in the case of a talking machine as an instrument which is played upon by the musician, since the former is used for the reproduction, instead of the production of the sound. But those who are making talking machine cabinets realize that in order for the machine to be permanently acceptable, and to do its best work at all times, the materials which go into it must be of a kind which will not warp, shrink nor pull apart.

"The rift in the lute' was simply a broken place in the body of this ancient musical instrument, forerunner of the violin, which interrupted the vibrations produced by the plucking of its strings, and destroyed the musical quality of its tone. A 'rift' or defective part of any kind in a talking machine would immediately result in the destruction of the tonal character of the music, and would substitute sounds far from pleasant.

"Realizing that every part going into the sound chamber, as well as other sections of the machine, must therefore be not only light enough to respond perfectly to the vibrations produced by the mechanism, but so manufactured as to resist temperature and climate and use, and to remain right for an indefinite period, designers of these machines have seen to it that veneered work be installed. And that is why the manufacturer of glued-up panels is being given the job of making the materials for the machine which is taking its place as the world's most popular product."

A GOOD RESOLUTION TO MAKE

To make this year one of the best you've ever had in "making good"—is a good resolution to make!

Ward's Khaki Moving Covers



Grade "D" Cover with No. 3 Straps.

PROTECT YOUR MACHINES FROM ALL KINDS OF WEATHER

and will enable you to deliver them free from dust, scratches, bruises and all other finish destroyers

Our covers are faced with Standard Khaki, lined with a heavy grade flannel, interlined with an exceptionally good grade of heavy cotton or felt, diagonally and closely quilted, and manufactured according to the usual superior "WARD New London" quality.

Grade "D", medium size,	\$6.00
Grade "D", large size,	\$6.50
Grade "K", medium size,	\$8.00
Grade "K", large size,	\$9.00

Carrying Straps: No. 1 \$1.00; No. 2 \$2.00; No. 3 \$3.50

ORDER SAMPLE COVER ON APPROVAL

With Name of Machine silk embroidered on any Cover; extra, .30c.
With Dealer's Name and Address, first Cover; extra, \$1.15
Same on additional Covers, each extra, .60c.

Write for booklet

THE C. E. WARD CO.

(Well-known Lodge Regalia House)

101 William St., New London, Ohio

Also Manufacturers of Rubberized Covers and Dust Covers for the Wareroom

DEALER SERVICE

In Connection with

VOCALION PUBLICITY

ON the two pages following are reproduced examples of the special advertising service now being extended to Vocalion dealers.

On the left-hand page is a reproduction of a full-page color advertisement—one of the series of such advertisements appearing monthly in the "Saturday Evening Post." Opposite is the newspaper reproduction in line of the same advertisement.

Proofs of these newspaper reproductions are sent to dealers with the information that mats of the advertisements set in four columns will be furnished in time to run in local newspapers simultaneously

with the appearance of this advertisement in the "Post." In this way the local merchant is enabled to "tie-up" with the Vocalion national campaign and direct its influence towards more specifically building his own individual business.

This is the most modern merchandising practice, the advantage of which is today fully recognized. Coupled with the unquestioned superiority of the Vocalion itself and the unapproached character of Vocalion publicity, it furnishes one more of the many weighty reasons why the most substantial music dealers throughout the country are Vocalion representatives.

Catalog and complete information sent upon request

THE AEOLIAN COMPANY

AEOLIAN HALL, NEW YORK



Hear the Vocalion Record of
 "Annie Laurie" as sung by
MAY PETERSON

PRIMA-DONNA SOPRANO
 OF THE METROPOLITAN OPERA COMPANY

May Peterson's career has been a phenomenally brilliant one. Following a number of years' study in Italy, she created a profound sensation in Paris as prima-donna soprano of the Opera Comique. Her success abroad has been followed by a no less notable triumph at the Metropolitan Opera House.

This great artist sings exclusively for the Vocalion Record, and her delightful rendering of this appealing old ballad discloses the beauty and flexibility of her voice as well as the extraordinary qualities of the Vocalion Record.



STYLE 800
 In Figured Mahogany
 Veneer or Circassian
 Walnut

The Perfected Phonograph of Today

THE AEOLIAN-VOCALION

THE production of the Aeolian-Vocalion, four years ago, signalized the entrance of a *great music house* into the field of *phonograph manufacture*. Before that time, phonograph development had been in other hands. Resourceful inventors and skilful mechanics had done wonders—had brought the phonograph from an ingenious toy to a mechanical marvel.

But wonderful as it unquestionably was mechanically, there was left much to be done in the way of developing its *musical possibilities*. Originally designed as a "TALKING MACHINE," its perfection as a **MUSICAL INSTRUMENT** could only be accomplished by skilful mechanics who were also trained musicians.

The staff of the Aeolian included such men—men possessed of this unusual combination of musical knowledge and mechanical talent and experience. It is

these men who have produced such instruments as the Aeolian Residence Pipe-Organ—the most ambitious and costly instrument ever made—the marvelous Pianola, the superb Steinway Duo-Art Pianola, and many others.

In the Aeolian-Vocalion, product of the Aeolian staff, the musical world was introduced to a new and superior phonograph, which was a true *musical instrument*. This instrument corrected defects of tonal reproduction, and substituted for the slightly metallic tone which has always been a characteristic of the phonograph, a clearer tone of great richness, depth and beauty.

In addition, it added to the phonograph the Graduola, an entirely new device for *controlling tone*, thus giving individuality to the phonograph and enabling the performer to participate, when he desired, in the actual playing of records.

VOCALION ADVANTAGES

TONE—The Aeolian Company's wide experience in tone production through various mediums—strings, reeds, pipes, etc.—have enabled it to construct a phonograph with a tone of unrivaled depth, richness and beauty.

TONE-CONTROL—The exclusive and revolutionary "Graduola" makes the Vocalion the only phonograph affording means for artistic and instinctive expression control. This new feature enables anyone to participate in the playing of the records, and adds immeasurably to one's enjoyment of the phonograph.

CASE-BEAUTY—The regular upright models of the Vocalion reflect the experience of its makers as fine-art instrument designers. In both outline and finish these established an entirely new standard of beauty, while the Period Styles, though inexpensive, are the most unusual and artistic phonographs ever displayed.

MECHANICAL PERFECTION—The Automatic Stop on the Aeolian-Vocalion—at once the simplest and most effective device of its kind—is an example of the degree of perfection manifest in every detail of the Vocalion's construction.

And the extraordinary new

UNIVERSAL TONE-ARM—This wonderful new feature enables the Vocalion owner to *play every make of record*—to hear *all* the great bands and orchestras. Without requiring any change of reproducer or parts and in the most direct and simplest way, it supplies what is now recognized as an essential to the up-to-date phonograph. Moreover, so scientifically is this Universal Tone-Arm constructed, that the Vocalion will not only *play* all records, but will play them *at their best*.

VOCALION PRICES

Conventional Models, equipped with Graduola, are priced from \$115 upwards; without Graduola from \$50. Many beautiful Period Models, priced from \$240.

THE AEOLIAN COMPANY

Makers of the Duo-Art Pianola Piano. Largest Manufacturers of Musical Instruments in the World

AEOLIAN HALL

In MANHATTAN
 29 West 42nd Street

In THE BRONX
 367 East 149th Street

In BROOKLYN
 11 Flatbush Avenue

In NEWARK
 895 Broad Street



The Perfected Phonograph of Today

THE AEOLIAN-VOCALION

THE production of the Aeolian-Vocalion, four years ago, signalized the entrance of a *great music house* into the field of *phonograph manufacture*. Before that time, phonograph development had been in other hands. Resourceful inventors and skilful mechanics had done wonders—had brought the phonograph from an ingenious toy to a mechanical marvel.

But wonderful as it unquestionably was mechanically, there was left much to be done in the way of developing its *musical possibilities*. Originally designed as a "TALKING MACHINE," its perfection as a MUSICAL INSTRUMENT could only be accomplished by skilful mechanics who were also trained musicians.

The staff of the Aeolian included such men—men possessed of this unusual combination of musical knowledge and mechanical talent and experience. It is

these men who have produced such instruments as the Aeolian Residence Pipe-Organ—the most ambitious and costly instrument ever made—the marvelous Pianola, the superb Steinway Duo-Art Pianola, and many others.

In the Aeolian-Vocalion, product of the Aeolian staff, the musical world was introduced to a new and superior phonograph, which was a true *musical instrument*. This instrument corrected defects of tonal reproduction, and substituted for the slightly metallic tone which has always been a characteristic of the phonograph, a clearer tone of great richness, depth and beauty.

In addition, it added to the phonograph the *Graduola*, an entirely new device for *controlling tone*, thus giving individuality to the phonograph and enabling the performer to participate, when he desired, in the actual playing of records.

VOCALION ADVANTAGES

TONE—The Aeolian Company's wide experience in tone production through various mediums—strings, reeds, pipes, etc.—have enabled it to construct a phonograph with a tone of unrivaled depth, richness and beauty.

TONE-CONTROL—The exclusive and revolutionary "Graduola" makes the Vocalion the only phonograph affording means for artistic and instinctive expression control. This new feature enables anyone to participate in the playing of the records, and adds immeasurably to one's enjoyment of the phonograph.

CASE-BEAUTY—The regular upright models of the Vocalion reflect the experience of its makers as fine-art instrument designers. In both outline and finish these establish an entirely new standard of beauty, while the Period Styles, though inexpensive,

are the most unusual and artistic phonographs ever displayed.

MECHANICAL PERFECTION—The Automatic Stop on the Aeolian-Vocalion—at once the simplest and most effective device of its kind—is an example of the degree of perfection manifest in every detail of the Vocalion's construction.

And the extraordinary new
UNIVERSAL TONE-ARM—This wonderful new feature enables the Vocalion owner to *play every make of record*—to hear all the great bands and orchestras. Without requiring any change of reproducer or parts and in the most direct and simplest way, it supplies what is now recognized as an essential to the up-to-date phonograph. Moreover, so scientifically is this Universal Tone-Arm constructed, that the Vocalion will not only play all records, but will play them *at their best*.

VOCALION PRICES

Conventional Models, equipped with Graduola, are priced from \$115 upwards; without Graduola from \$50. Many beautiful Period Models, priced from \$240.

THE AEOLIAN COMPANY

Makers of the Duo-Art Pianola Piano. Largest Manufacturers of Musical Instruments in the World

AEOLIAN HALL

In MANHATTAN
29 West 42nd Street

In THE BRONX
367 East 149th Street

In BROOKLYN
11 Flatbush Avenue

In NEWARK
895 Broad Street



Hear the Vocalion Record of
"Annie Laurie" as sung by
MAY PETERSON
PRIMA-DONNA SOPRANO
OF THE METROPOLITAN OPERA COMPANY

May Peterson's career has been a phenomenally brilliant one. Following a number of years' study in Italy, she created a profound sensation in Paris as prima-donna soprano of the Opera Comique. Her success abroad has been followed by a no less notable triumph at the Metropolitan Opera House.

This great artist sings exclusively for the Vocalion Record, and her delightful rendering of this appealing old ballad discloses the beauty and flexibility of her voice as well as the extraordinary qualities of the Vocalion Record.



STYLE 800
In Figured Mahogany
Veneer or Circassian
Walnut



The Famous
Belgian 'Cellist

MAURICE DAMBOIS
WILL MAKE
VOCALION RECORDS EXCLUSIVELY

MANY critics have pronounced this distinguished young artist the greatest 'cellist of our day. Certain it is that the Vocalion Records of his art are the most beautiful phonograph reproductions of 'cello music ever heard. Appealing and sympathetic as the 'cello is always, the Dambois Vocalion Records bring out in perfection the natural beauty of the instrument and present a wonderful tone-picture of the playing of this master 'cellist.

MAURICE DAMBOIS was born in Liege, Belgium, in 1889. Like most musical artists who are entitled to be called "great," his extraordinary talent became evident at a very early age. He made his debut before Her Majesty Queen Marie-Henriette of Belgium at Spa, playing the Saint-Saens Concerto in A Minor, and at the age of fifteen was acclaimed a virtuoso. Dambois' tone is unsurpassed in its purity and depth, and his interpretations are characterized by a wealth of poetic feeling.

The AEOLIAN-VOCALION

A phonograph of broader musical powers



Style 400
Price \$115

THE Vocalion is in itself a phonograph of highest quality. It has several special and unique advantages, moreover, which will interest anyone contemplating the purchase of a new phonograph.

The Vocalion lends itself to the playing of all standard records—imparting to each the full musical quality of which it is capable.

With the fascinating tone-controlling device, the Graduola, the listener becomes at will a performer and artistically varies the

tone-color and accents of the recorded music.

As artistic in appearance as it is in musical quality, a Vocalion may be chosen to harmonize with any room decoration, for, besides the handsome standard models, there are sixteen exquisite Period Styles at moderate prices.



The Vocalion records of Maurice Dambois will be played for you at any time.

THE AEOLIAN COMPANY

Makers of the Famous Pianola. Largest manufacturers of musical instruments in the world

In MANHATTAN
29 West 42nd Street

AEOLIAN HALL

In THE BRONX
367 East 149th Street

In BROOKLYN: 11 Flatbush Avenue

In NEWARK: 895 Broad Street

A. J. PALMER ADVERTISING MANAGER FOR EDISON CO.

Succeeds Leonard C. McChesney, Whose Death Was Announced Recently—His Thorough Training in Publicity and Phonograph Fields Eminently Fits Him for This Important Post

Announcement is made by Thomas A. Edison, Inc., of the appointment of Arthur J. Palmer, formerly assistant advertising manager, to the position of advertising manager, made vacant by the recent death of Leonard C. McChesney.

Mr. Palmer began his business career as copy boy for the American Press Association, New York. He became in succession exchange editor, news editor, special writer, and editor of The American Press, a trade paper for newspaper men and the house organ of the American Press Association. Following that he went South, holding for three years the position of publicity manager for the Montague Mailing Co., of Chattanooga, Tenn. His next position was that of sales and advertising manager of the Brand Mfg. Co., of Brooklyn, N. Y.

Mr. Palmer became connected with Thomas A. Edison, Inc., in November, 1915, as assistant advertising manager. His work for the past three years in that capacity has made him well known in the phonograph world. He brings to his new duties a thorough knowledge of the phonograph business not only from the advertising standpoint but from every other angle as well. He comes peculiarly fitted for his position. He can judge advertising copy because he can write it himself. He has demonstrated that in the past by writing some of the most "pulling" copy ever put out by Thomas A. Edison, Inc. Added to his knowledge of the technique of advertising Mr. Palmer has a thorough and most practical

knowledge of all the printing, engraving and allied arts. His comparative youth for so re-



Arthur J. Palmer

sponsible a position (he is thirty-four years of age) makes his future a most promising one.

MUSICAL IMPORTS INTO AUSTRALIA

Total \$1,765,000 in Year Ending 1917, of Which a Large Proportion Came From the United States—Exports to New South Wales

The growth of business between the United States and Australia, and particularly the growth in exports from this country to Australia, is indicated by the fact that for the fiscal year ending 1916 the total imports of musical instruments were \$1,604,337, and during the fiscal year ending 1917 the imports of musical instruments amounted to \$1,765,230. In the State of New South Wales alone musical instruments during the years 1916-17 to the value of \$604,871 came from the United States, divided as follows: graphophones and records, \$180,060; pianos, upright, \$424,811. The figures would seem to indicate that there still remains an opportunity for increasing our exports of musical instruments to the Australian States.

BAN LIFTED FROM TRAVELERS

The executive order issued by the President on August 8, 1918, forbidding any person registered or subject to registry for military service in the United States to leave the country without the previous consent of the Secretary of War has been revoked. This act is of special interest to traveling men entering Canada, who will thus be able to make their trips into that territory without wading through considerable red tape.

DEATHS OF THREE DEALERS

LeRoy Williams, of Dillon, S. C.; Mr. Sasser of Sasser Furniture Co., Mount Olive, N. C.; and H. L. Land, of Hamlet, N. C., three Edison dealers, recently died of influenza and pneumonia according to announcement made by The C. B. Haynes Co., Inc., Edison distributors of Richmond, Va.

The Talking Machine World
Extends to Its Readers
Best Wishes
For a Merry Christmas
And a Prosperous New Year

FEATURE SALES ARGUMENTS

Three Artistic Car Cards Bearing on Pathé Records Just Issued

The Pathé advertising department has just issued for the use of its dealers three artistic car cards that feature different sales arguments. One of these cards calls attention to the new Pathé demonstration record that has met with a phenomenal sale. This record has on one side a quartet selection and on the other a group of instrumental and vocal demonstrations that give the dealer an opportunity to emphasize the distinctive characteristics of Pathé recording.

Another card in this series features the Pathé Sheraton model, an art model phonograph that has met with a ready sale throughout the country. The third calls attention to the round Pathé sapphire ball, which is used on Pathé phonographs instead of sharp needles. On this card there is also presented an illustration of the Model 7 Pathéphone.

OPENS SILVER GRAFONOLA SHOP

On the first of the month, the Silver Grafonola Shop opened a handsome establishment at 22 Delancey street, New York, which promises to be one of the most successful retail phonograph establishments in that part of the city. This store handles the Columbia and Victor lines, and Irving A. Silver, head of the concern, is leaving nothing undone to give his patrons efficient service. Mr. Silver is also the head of the Marconi Phonograph Co. at 106 Delancey street, and the experience that he has gained during the past twelve years has been utilized to excellent advantage in the decoration and furnishings of the new Silver Grafonola Shop. There are twelve sound proof booths in this store, and an indirect lighting system is used that adds to the beauty of the interior.

WISE TO CLASSIFY ONESELF

No man is indispensable, but some are more useful than others. It is a good idea to figure out your own classification once in a while, then try to find a way to improve it.

NYOIL

is the last word in the refining of high-grade oils, for every impurity is taken from it, leaving nothing but what is required to keep machines in perfect condition, being combined of four oils perfectly blended.

Will not Gum, Chill or become rancid; is free from acid. It is colorless and has no sickening smell, being absolutely odorless.

"The finest and most delicate pieces of mechanism do not prove efficient unless properly lubricated. Skill, Genius, Invention and Workmanship must have the proper Oil. Stop and consider this when you have to buy an Oil for household use."

Hundreds of satisfied customers have written us that they would never use anything else for

TALKING MACHINES, GRAPHOPHONES, PHONOGRAPHS AND SEWING MACHINES

NYOIL will lubricate the machinery and polish all woodwork

and can be obtained of any "Up-to-date" Talking Machine Dealer in the world, and is manufactured by Wm. F. Nye, who for 50 years has made 80% of all the Watch, Clock and Chronometer Oil that is used in America.

WM. F. NYE, NEW BEDFORD, MASS., U. S. A.

NYOIL is put up in the following sizes:

No. 16 (Cans)	1 Pint
No. 32	1 Quart
No. 128	1 Gallon
No. 540	5 Gallon

NYOIL is put up in the following sizes:

No. 1 Bottle	1 ounce
No. 4	3 ounces
No. 8	8 ounces

Edison Message No. 32

PEACE!

Every nation of the Earth is thrilled with the joy of Peace! The wonderful Paean of Liberty's Victory is ringing 'round the world! They are singing the "Marseillaise" in the streets of Berlin.

The dull, dread pain of war is lifted at last from the hearts of our people. An era of rejoicing, of loosened purse-strings, of preparation for the homecoming of our boys, is at hand.

Edison dealers must see it as their duty to use their every effort in furthering music's place in these rejoicings. Music in the home must be part of the preparing welcome for the returning soldier. It has been our greatest solace; it must be now our greatest inspiration for the new and better world-life before us.

THOMAS A. EDISON, Inc.
ORANGE, N. J.

The Application of Period Decoration to Talking Machine Cabinets—The Henry IV Style

The exploitation of period styles in talking machine cabinets, which threatened for a time to be hindered or stopped entirely as a result of the wartime conservation orders issued by the Government officials, is again possible through the welcome fact that the war has drawn to a close and industries can again turn their attention to peace-time pursuits, and the normal problems of business.

As is generally known, the Government order limited the number of styles to be produced by each manufacturer to six, but with the restriction removed, there is now no limit to the number of special case designs which the manufacturer may produce and offer to the public. This freedom of movement, however, should be accepted in a business way. An unlimited number of cabinet designs in any one line does not of necessity indicate manufacturing efficiency. In fact, it means quite the contrary. The more styles the greater the manufacturing expense, and likewise the greater selling expense, because the dealer, if he features a complete line, must tie up that much more capital in his sample and regular stock. The thing, then, is to design a comparatively few period cabinets of such authenticity and excellence that they will prove readily salable.

As the various manufacturers present new models patterned after leading French, English and Italian decorative styles, the value of originality in the designing of period cabinets becomes more pronounced, for duplication effort

and sameness of design is not to be introduced under ordinary conditions, and is, in a measure, to be condemned in the case of period designs.



The Henry IV Style Fits Modern Requirements

There are a large number of accepted period styles that are most attractive and offer a wealth of detail, but with which the public as a whole is not familiar. In the French school, for instance, practically everybody who is at all well informed knows of the various Louis styles, particularly the Louis XIV, XV and XVI, as well as the Empire style. There are other periods of French decorative art that bespeak as great,

if not greater, consideration from the cabinet designer of to-day. There is, for instance, the style of Henry IV of France, during the course of whose peaceful reign the arts and sciences in France prospered to an unprecedented degree. Henry IV is better known perhaps as the famous Henry of Navarre.

Henry IV became nominal King of France in 1589, upon the death of Henry III, but it was not until 1594 that he was crowned. In 1600 he married Marie de Medici, and the progress in the decorative arts during the succeeding ten years of his reign was due primarily to her influence. Marie de Medici was thoroughly Italian, and she introduced a touch of Baroque into the purer Renaissance style of France which led the way ultimately to the creation of the Rococo of Louis XV. It was during the reign of Henry IV that the great work of extending the Tuileries, and the completion of the long gallery connecting the Louvre and the Tuileries was completed. Next in line was the addition to Fontainebleau of a great court to the eastward. Many furnishings for the buildings proper and for the additions were imported from Italy, but French artists put forth their efforts so successfully as to supplant the importations and rise to supremacy.

During this reign the shell was first introduced in France as a decorative motif in wood-carving. At first it was confined to finials of chairs and cabinets, where it was extremely effective, but it soon passed into more general use and led eventually to the Rococo.

In many of the details given in the accompanying cut, there is a noticeably close resemblance to the forms used in our Colonial style. This is because the Henry IV style in a large measure followed the Greek quite closely; but a closer study of the style will show that while the details may be similar the spirit that governed their use was far different from our Colonial spirit. In color and elaboration the Henry IV was far more regal, as befitted a style that had its origin and development in a court and may be said to be, in a sense, the application to the palace of details that in Colonial days were adapted to the home.

The contemporary English styles were the later Elizabethan and Early Jacobean, and the decorative style of both France and England was distinctly the trend of the classic influence.

In the details shown herewith, the designer of talking machine cabinets should be able to find much material with which to embellish his work. There is a richness about the Henry IV style that fits in well with modern ideas of decorative treatment, for the style is actually the forerunner of modern decorative styles.



AUTOMATIC COVER SUPPORT No. 1287
 OPERATED WITH ONLY ONE HAND
SIMPLE — SUBSTANTIAL — ECONOMICAL
 FINISHED IN GOLD OR NICKEL PLATE

Accomplishes all that any other type of one-position support does—at about half the cost.

We manufacture hardware for all styles of cabinets

Lid Supports	Door Catches	Sockets
Needle Cups	Sliding Casters	Tone Rods
Needle Rests	Continuous Hinges	Knobs, etc.

BEST QUALITY **LOWEST PRICES**

WRITE TO-DAY FOR QUOTATIONS

WEBER-KNAPP COMPANY **Jamestown, N. Y.**



No. 1265

WITH AND WITHOUT COVER

FURNISHED IN ANY FINISH

THE TRADE IN BOSTON AND NEW ENGLAND

JOHN H. WILSON, MANAGER, 324 WASHINGTON STREET, BOSTON, MASS.

BOSTON, MASS., December 2.—Business is very good everywhere. The cessation of hostilities on the other side has created a new atmosphere which is felt by trade generally. The ban is being lifted in all lines of activity, and while factories are allowed a more normal output of goods the real results of this good intent are not likely to be felt until long after the holidays, as factories, so it is stated in the local trade, will not be in a physical position to meet the increasing demands for goods until well into the new year. The result is that many Christmas orders will go unfilled. One compensating feature of the situation that the trade has been facing is the fine attitude of the dealers, who, for the most part, have accepted an unpleasant condition gracefully. Along with all other departments of business the talking machine houses took a holiday on the day the armistice was signed, and the following day was officially declared a holiday by the Governor, so here the workers virtually enjoyed two days' respite from business.

G. A. Dodge Enters Talking Machine Business

It will be interesting news to the local trade to learn that George A. Dodge, widely known in Boston business circles, has entered the talking machine business. Mr. Dodge, who has been identified with the hotel business, and whose name has for several years been associated with Paragon Park and the Palm Garden at Nantasket Beach, has purchased a controlling interest in the Eastern Talking Machine Co., having acquired the holdings of the estate of Elton F. Taft, president of the company, who it will be recalled died quite suddenly several months ago.

Mr. Dodge brings to the business large experience, a keen sense of values, a knowledge of men and a mind always receptive to new ideas. It is a part of his plan to make a physical separation of the wholesale and retail departments, and if the present plans are carried out it is likely that by the first of the year the wholesale business will be moved to 18 Oxford street, where the Eastern Co. has long maintained a large storage plant for its Victor line. Mr. Dodge has met several of the leading Victor officials and his policy, which he has mapped out in considerable detail to them, has met with their approval, and they have been quick to see in him a man of progressive ideas, one who would be able to push the Victor proposition to the greatest success. In the meantime William

J. Fitzgerald, who has made himself a necessary factor in the Eastern Co.'s business, is cordially co-operating with Mr. Dodge in all his plans which he has on foot to develop the business of this company, which is one of the few houses in the city exclusively handling the Victor line and no other line of merchandise.

Thomas W. Hindley Married

Thomas W. Hindley, manager of the Vocalion Co., was married on the evening of Tuesday, November 26, to Miss Ethel H. Hayden, of Watertown. The ceremony was performed at the First Baptist Church of that town by Rev. C. H. Day. The bride was gowned in white satin and carried bride roses. She had three attendants, while Mr. Hindley's brother, Edward Hindley, was the best man. Of the quartet of ushers two of them, Charles T. Foote and Amos E. Russell, are members of the Vocalion staff. Mr. and Mrs. Hindley started off on a wedding trip to New York, and they are to make their home at 10 Radcliffe road, Allston.

Returns to Civil Life

Amos E. Russell, of the Vocalion staff, did not have much of a chance to see service, for he had not been at the officers' training camp at Camp Lee, Virginia, before the armistice was signed, and shortly after the camp was demobilized, and the candidates sent back into civil life, Mr. Russell returning to his Vocalion duties in time to eat his Thanksgiving dinner with his family.

Demand Largely Exceeds the Supply

R. O. Ainslie, of the Pathé department of the Hallet & Davis Co., reports that there are fully ten dealers for every machine that can be had, and it is a vexing problem how to supply the trade so that there are no hard feelings. Ainslie further states that the very Monday the armistice was signed business began to pick right up, and dealers who hesitated to place orders hesitated no longer. Mr. Ainslie, by the by, is the proud father of a bouncing baby daughter, Elinor Virginia by name, who came into the world on All Hallowe'en.

Business Expands Since Armistice Was Signed

At the Columbia headquarters one learns that the dealers are reporting increased business, which became conspicuously noticeable, so one of the local officers stated, the very day that the armistice was signed. In view of the scarcity of goods the wholesale house has been reluctant to take on any new connection but one which

has been signed up is the Pilgrim Talking Machine Co. in Cambridge street, Cambridge. Edward Lanigan, one of the employes of the Columbia who was with the K. of C. at Camp Devens, Ayer, has lately been transferred to Camp Mead, Virginia. C. E. Sheppard, of the field force of the house, spent Thanksgiving with relatives in Philadelphia.

To Exploit the OkeH Records

George J. Krumscheid, lately with Herbert L. Royer, where he was active in pushing the Cheney proposition, and C. R. Johnson, formerly with the Brunswick, have associated themselves with Richard M. Nelson, local manager of the Electric Supply & Equipment Co., of Hartford, Conn., and will travel through Maine, New Hampshire and Vermont in the interests of the OkeH records and the Vocalstyle rolls. The Electric Supply & Equipment Co., which is the distributor for the OkeH records for the entire New England, has been meeting with marked success in placing this line, as many as 150 dealers now carrying these records, many of these same dealers also being phonograph enthusiasts. H. E. Page, president of the Electric Supply & Equipment Co., was a recent visitor in this city.

Many New Emerson Dealers Take Hold

H. L. Coombs, since taking hold of the local offices of the Emerson Co., has been able to distribute a very large number of records and the business is growing fast in this territory. The Iver Johnson Sporting Goods Co., whose talking machine department is managed by Arthur W. Chamberlain, has just taken on the Emerson ten-inch line, samples of which have just arrived at Manager Coombs' offices. Three new dealers who have just taken on the nine-inch line are Lionel Fontaine, Inc., of Manchester, N. H., and Fred W. Gardner and Oscar E. Messier, both of Lawrence.

Columbia Monthly Meeting a Success

There was a large company of Columbia dealers at the meeting held at the Columbia's wholesale headquarters in Federal street the evening of November 26. Manager Fred E. Mann presided, and gave the dealers an excellent talk bearing on business methods, and O. F. Benz, of the general sales department, was here from New York to enthrall the boys over the prospective lists, many of which are sure to be popular. Special interest centered in the appearance of Charles W. Harrison, one of the Co-

The Signing of the Armistice

While not immediately clearing up the obstacles to the resumption of normal conditions throughout the trade, does shed a light on the good business that can be expected in the future.

The same hearty co-operation that we have extended in the solution of war-time problems will be continued in the still greater period of expansion that is ahead.

EASTERN TALKING MACHINE CO.

177 Tremont Street

BOSTON, MASS.

Victor Distributors

Send for Descriptive Circular

Curry DEMONSTRATION BOOTHS
AND RECORD CASES
IN STOCK OR TO ORDER

"SOUND PROOF"

FRANK B. CURRY
19 Wareham St. Boston, Mass.

lumbia artists who sang a number of the selections put out by the company. Looked at from every angle the meeting was productive of great good for both the Columbia and its many dealers, who are fed through Manager Mann's department. Mr. Mann, by the bye, had the honor that same day of meeting Major-General Clarence R. Edwards, who led the gallant Twenty-sixth Division across in France, and for whom there was a luncheon given that same noon at the Boston City Club, of which Mr. Mann is a member.

Will Get Back Into the Fold

F. H. Walter, who lately was with the Brunswick line has been heard from at the Pelham Naval Station, whither he went several weeks ago. From a letter The World correspondent received from him it is evident that it will not be long before the camp breaks up and already he is laying plans for getting back into the game, preferably in the wholesale end of the talking machine business. Mr. Walter made quite a success with the Brunswick proposition while in this territory.

Joins the Chickering Talking Machine Dept.

Manager Ralph W. Longfellow, of the Victor and Edison department of Chickering & Sons, is putting in some hard work these days, but is handicapped through the difficulty of getting adequate help for his warerooms. The latest acquisition to his staff is Miss E. D. Wynott, who formerly was with the Rosen shop in School street. Mr. Longfellow reports that there is a good call for both machines and records.

Report a Large Volume of Business

The Victor department of the Oliver Ditson Co. has been having a splendid business, and Manager Henry Winkelmann seems able by tact and unfailing good nature to satisfy the trade. Now that the epidemic is over the retail department is the focal point of lovers of Victrola music.

Hearty Welcome for John Alsen

George Lincoln Parker and his staff are looking forward expectantly to the return of John Alsen, who has been in France since a year ago last September. It will be recalled that Alsen was wounded several months ago and for some time was in a base hospital, but at last accounts

MANUFACTURERS— JOBBER—DEALERS



Perfection Universal Tone Arm and Reproducer No. 6 set in position for playing "lateral" cut records.



Perfection Universal Tone Arm and Reproducer No. 6 set in position for playing "hill and dale" cut records.

Our PERFECTION line of tone arms and reproducers are now complete and are attachable as follows:

- No. 3 tone arm and PUR-I-TONE reproducer plays Victor and Columbia records on Edison Disc Machines.
- No. 4 tone arm and Nos. 4, 7 and 8 PUR-I-TONE reproducers play Victor and Columbia records on Edison Disc Machines.
- No. 5 tone arm with PUR-I-TONE reproducer plays all makes of hill and dale records on Edison Disc Machines.
- No. 6 UNIVERSAL tone arm and PUR-I-TONE reproducer plays ALL makes of records on Edison Disc Machines.
- Nos. 3 and 7 PUR-I-TONE reproducers are fitted to Columbia machines for playing Victor and Columbia records.
- No. 7 PUR-I-TONE reproducer is fitted to Victor machines for playing Victor and Columbia records.
- No. 11 PUR-I-TONE reproducer plays all makes of hill and dale records on Victor machines.
- No. 11-A PUR-I-TONE reproducer plays all makes of hill and dale records on Columbia machines. No. 11 and 11-A reproducers are especially fitted to Victor and Columbia machines, and are easily the finest built in the world. Guaranteed not to blast on any record, and will reproduce Edison Disc records with perfect clarity of sound, also with excellent volume and resonance of sound.
- No. 9 PUR-I-TONE Reproducers fitted to Brunswick machines that have tone arms with detachable reproducers.

First-class high-grade product, finely plated and carefully assembled, making this line the leading phonograph accessory line of the world.

Phonograph dealers write us from all over the country, saying that they have tried all makes of reproducers, and are greatly bothered with various makes of reproducers blasting. Particularly, on high pitched soprano records.

FLEXI-TONE and PUR-I-TONE reproducers do not blast.

Send for a sample and you will find this statement to be a fact.

Manufactured by
New England Talking Machine Co.
The Largest Manufacturers of Phonograph Accessories in the World
16-18 BEACH STREET BOSTON, MASS.
Pacific Coast Distributor: WALTER S. GRAY
Chronicle Building, San Francisco, Cal.

Write for prices and information as to how these accessories are attached and used on the leading makes of phonographs

was making good recovery and was expecting to get back to the front. Alsen is the manager of the Edison and Victor department in Mr. Parker's establishment.

Some Steinert Changes

News from the Victor department of M.

Steinert & Sons Co. include the fact that Russell L. Steinert, the general manager of the house, who left for Washington several weeks ago to engage in aircraft construction, has received his commission as second lieutenant. Robert Stein-

(Continued on page 24)

— **Oldest and Largest** —
**Manufacturers of Talking
Machine Needles in the
World—There are several reasons**

W. H. BAGSHAW CO., Lowell, Mass.

THE TRADE IN BOSTON AND NEW ENGLAND (Continued from page 23)

ert, the younger brother, who has transferred his office from the Arch street store, which is the Victor headquarters, is taking up Russell Steinert's duties. In Russell Steinert's place is Kenneth E. Reed, who as manager of the wholesale department reports that, owing to inability to procure the popular-priced instruments, the retail staff is devoting its energies and success to the higher-priced lines.

Joins Forces With H. L. Royer

Clinton W. Royer has entered the employ of his brother, Herbert L. Royer, and will push the Cheney proposition for all it is worth in this territory. C. F. Wing, of New Bedford, is the latest house to be signed up for the Cheney.

Attractive Harvey Window for Christmas

An enormous Santa Claus dressed in red fills the rear of the window of the C. C. Harvey Co., and as suggestions for Christmas gifts are some handsome models of Edison and Victor machines, together with collections of records. The window decoration is the work of Vesper L. George, the well-known artist.

Congratulations for D. A. Ingalls

Traveling Associate D. A. Ingalls, who covers Vermont for the Columbia Co., and who occasionally gets to this city, is receiving the congratulations of his many friends. He is the father of a son, born on October 24, and the youngster is doing nicely.

New England T. M. Co. Expansion

Finishing touches are being placed by a force of carpenters and painters on the new quarters to be occupied by the assembling department of the New England Talking Machine Co. This is in addition to the already large quarters occupied by this firm at 16-18 Beach street. The steadily and fast increasing popularity of the "Perfection" line of reproducers and ball bearing tone arms has made this enlargement an absolute necessity.

"October has been a record month," reports President Chas. P. Trundy. "It has eclipsed all monthly records for four and one-half years."

A PROGRESSIVE NEW ENGLANDER

Columbia Grafonola Being Featured in Springfield, Mass., by Frank Yahn

SPRINGFIELD, MASS., December 6.—Frank Yahn, who conducts the talking machine department of Poole's Court Square store in this city, has been carrying some very attractive announcements in the illustrated sections of the local papers in which he has been featuring the Columbia Grafonola art designs to very excellent advantage. Mr. Yahn is an old-time talking machine man, having been connected with the Columbia store in this city. When that business was closed he organized the talking machine department of Albert Steiger's Holyoke store, where he first developed the "Frank Yahn Service" idea for the sale of talking machines in department stores, a business of which Mr. Yahn is the owner and manager. A department was opened in the new Steiger-Cox store in Fall River in September, 1917, followed soon by a similar department in the Court Square store in Springfield, and a third department was opened last November in the Steiger-Dudgeon store in New Bedford.

EXPANDING HIS PLANT

BOSTON, MASS., December 4.—Frank B. Curry, manufacturer of the "Curry" soundproof demonstration booths and store fixtures of 19 Wareham street, this city, reports an increasing number of installations. The steadily increasing business has made it necessary for Mr. Curry to make plans for an early extension of his plant. The Curry booths are giving satisfaction in some of the foremost and most attractive talking machine shops in this country.

Bailey's music store, Burlington, Vt., has enlarged its Victor and Edison departments, increasing its stock of machines and records to meet growing demands.

"THE PEPTIMIST" FOR NOVEMBER

Many Interesting Articles in This Publication Covering Varied Columbia Activities

The November issue of "The Peptimist," the snappy house organ published monthly by the Columbia Co. for and about Columbia men, contains many interesting articles regarding the activities of the members of the Columbia sales staff in different parts of the country. This house organ is meeting with remarkable success, and every Columbia salesman awaits with interest the receipt of each issue.

On the back cover of the November issue of "The Peptimist" there are reproduced various sections of the Columbia dealer service window displays that emphasize the timeliness and effectiveness of this service. It is suggested that Columbia salesmen call the attention of their dealers to the value of these displays, which can be utilized to splendid advantage in developing record business.

On another page of the November issue there is visualized the tremendous scope of Columbia national advertising by means of a composite illustration of the large number of magazines that carry the Columbia message to the public. The circulation of these magazines is enormous, and this illustration emphasizes the dealer cooperation that is represented in this publicity.

NATIONAL TOY CO.'S NEW QUARTERS

BOSTON, MASS., December 1.—The National Toy Co., of this city, manufacturers of toys and specialties for the talking machine trade, have removed to larger quarters at 167 Oliver street. Ragtime Rastus, the Boxers and Uncle Sam and Kaiser Bill are three novelties in their line that have received nation-wide reputation.

Trade building, like house building, depends just as much upon the mortar as upon the bricks. Good merchandising demands skill in placing the cementing material.

The Duo-Tone

(LASTS A LIFETIME)

Equipped with tungsten needles
Each needle plays 100 to 300 records

Soft or Loud

without

changing
Needle

(Enlarged
View)

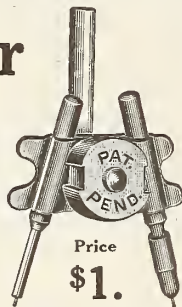

Price
\$1.

DEALERS: It might not be any bother for you or your salespeople to change needles, possibly because you are accustomed to it by changing them day after day and week after week, but have you ever taken into consideration the wants of your customers, who possibly only play their instrument an hour or two an evening one or two evenings a week?

To your customers the changing of needles is a bother and many of them have so informed you.

The Duo-Tone eliminates this bother and a record can be played loud or soft without releasing thumb screw and shifting needles.

Your discount is 40%

"Crank on Tone"

Say

The DeLuxe Stylus

Loud or Soft

Is the best semi-permanent Needle on the Market

With reasonable care it plays 100 to 300 Records

Does not Scratch or Hiss. 30c per package of three

The secret of their success is
PERFECT POINTS

Sold and indorsed by many of the Big Jobbers and Dealers

Your discounts on the De Luxe are 30 and 10%

With your initial order for 12 Duo-Tones and 50 packages of De Luxe Needles we furnish besides descriptive circulars for your mailing list an attractive Counter Display Stand or Silent Salesman, containing the Duo-Tones and De Luxe needles properly displayed.

Samples and circulars sent on request

REPRESENTATIVES:

Pacific Coast
WALTER S. GRAY, 508 Chronicle Bldg.
San Francisco, Cal.

Southern
PHILLIPS & CREW PIANO CO.
Atlanta, Ga.

THE STARR PIANO CO.
Birmingham, Ala.

Middle West

J. W. JENKINS' SONS MUSIC CO.
Kansas City, Mo.

THE STARR PIANO CO.
Richmond, Ind.

THE W. H. BUESCHER & SONS CO.
Cleveland, O.

THE WHITNEY CURRIER CO.
Toledo, O.

New England

M. STEINERT & SONS CO., Boston, Mass.
OLIVER DITSON CO., Boston, Mass.
J. SAMUELS & BROS., INC., Providence, R. I.

Others

THE STARR PIANO CO.
11 East 37th Street
New York, N. Y.

THE STANDARD TALKING MACHINE CO.
Pittsburgh, Pa.

PLACE A TRIAL ORDER NOW WITH YOUR JOBBER OR MAIL IT TO US

The Duo-Tone Company, Ansonia, Conn.



**THE WINDSOR
FURNITURE COMPANY**
1420 CARROLL AVENUE
CHICAGO, ILLINOIS
ESTABLISHED 1885,



Consider the Windsor

WHEN you are making your plans for next year, bear in mind that all the Windsor designs are patented and don't include infringements in your line.

The Windsor cabinets are the result of our thirty years' experience in making art furniture of the highest quality. The Windsor Phonograph is a perfect musical instrument, designed, built, and finished by experts, for people of discriminating taste, who want something more than a mere talking machine.

Retail Prices range from \$80 to \$800.

Write for a Catalogue.

Windsor Furniture Company

1420 CARROLL AVENUE

CHICAGO, ILL.

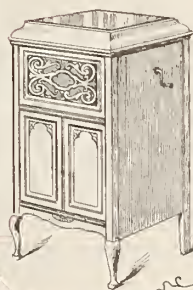
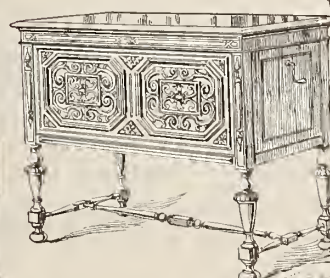
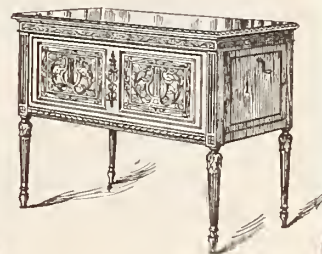
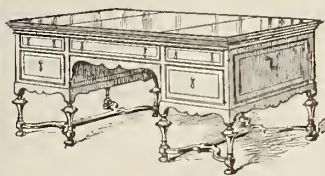
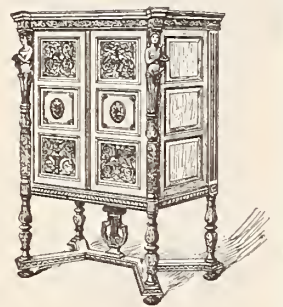

*The Windsor
Phonograph*



LIST OF THE WINDSOR PHONOGRAPH CABINET PATENTS

48122

50478

50481

50484

49654

50479

50482

1279743

49655

50480

50483



Not too late to change that window trim again before Christmas. Make your windows work overtime from now until the 25th.

**Columbia Graphophone Co.
NEW YORK**

NASHVILLE A BUSY TRADE CENTER

Bond's Graphophone Shop Tells of Expansion—Houck Co. Doing Well With Victrola—Urban Prosperity Helps Industry Generally

NASHVILLE, TENN., December 6.—Bond's Graphophone Shop, 38 Arcade, this city, E. E. Hyde manager, reports that their 1917 business is three times larger than during 1918. Mr. Hyde says that the first half of November was larger than all November last year and that the month was the best this year. His record business is exceedingly fine, and he is selling all goods as rapidly as they can be received, unpacked and placed on display. Their Grafonola sales have increased phenomenally, and a considerable part of this business is undoubtedly due to the fact that the big powder plant near Nashville, employing at one time 40,000 men and women, has turned loose a world of money in Nashville. At the same time all classes of people seem to have more money to spend than ever before and the talking machine dealer has profited thereby. Mr. Hyde is very optimistic for the future, and is planning some big things for the year 1919.

The O. K. Houck Piano Co., Victor jobbers and retailers, have been and are doing a most satisfactory business. The Houck Co. are Victrola specialists and are so well known, well equipped and managed, and keep at all times such a complete stock of Victrolas and Victor records that their business is always good.

H. Brown & Co., dealers in the Grafonola exclusively, have been and are doing a large and satisfactory volume of business. Herman Stelzer, firm member and who has the department under his immediate jurisdiction, is pleased with the way things are going, and is replenishing his stock to the limit of the jobber's ability to supply, in anticipation of a record holiday trade.

The high price of tobacco which is raised in considerable volume around Nashville, the fine prices for mules, hogs, cattle, poultry, cereals and all other crops and the universal employment of everyone who wants to work at good wages have contributed to the general prosperity of this city and throughout Middle Tennessee generally.

Nashville is to be congratulated on the magnificent parade here on Monday, November 11, Peace Day. It was equal in volume and in attractiveness to anything that your correspondent has seen for a long time. The city and district far exceeded their quota in the War Work Campaign for The Red Cross and allied causes, and much of the success is due to Vernon Tupper, chairman of all committees to raise funds.

GERMAINE SUCCEEDS FOSTER

Albert St. Germaine has succeeded I. W. Foster as the traveling representative of the Montana Phonograph Co., Edison jobber of Helena, Mont.

SOSS FACTORY NEARLY COMPLETE

Soss Mfg. Co. Preparing for Post-War Activity—New Plant Will Have Every Modern Facility for Making Soss Invisible Hinges and Die Castings for Player Actions and Talkers

Preparations for post-war activities are being made by the Soss Mfg. Co., 435 Atlantic avenue, Brooklyn, who are now erecting a new factory at Grand avenue and Bergen street, Brooklyn. The building, which is three stories in height, of brick and concrete construction, comprising 20,000 square feet, is being built under the supervision of Joseph Soss, head of the company, who for many years was one of the leading builders of the State of Montana.

The first floor will be equipped with fifty various kinds of stamping presses, while the second floor will be devoted to the tool and die casting department, as well as plating, finishing, packing and shipping. On the third floor will be located the die casting department. The cleaning and assembling departments will also be located on this floor. The company is also erecting directly next to the factory a thoroughly modern garage in which three auto trucks will be kept.

With the new equipment at its disposal, which it is hoped will be immediately after the first of the new year, the company will be in a position to take care of a greatly increased volume of business.

For many years the company has been well known, owing to its manufacturing the Soss invisible hinges, which are universally used on pianos, player-pianos and talking machines. In the last few years a die casting department has been developed, as well as a splendid business in this line for the die casting of metal parts for player actions and talking machines, as well as those for other commodities. The new factory will be thoroughly modern in every respect, and has been planned so that the processes of manufacture will be done in a most progressive manner.

TRADE CONDITIONS IN CHATTANOOGA

Templeman Co. Doing Best Business in History—Sterchi Bros. Tell of Good Prospects in All Their Stores—All Retailers Optimistic

CHATTANOOGA, TENN., December 9.—The Templeman Piano Co., this city, Miss Edna Burchfield, manager of the Grafonola department, are doing the best business in their history in talking machines and records. The cantonment at Chickamauga Park near here has contributed considerably to the volume of business, especially in records. Miss Burchfield says that they are selling phonographs as fast as they can get them, and expect the largest holiday business in their history. Their store, fully stocked with all types of Grafonolas and records, is on Market street, the principal shopping center in Chattanooga, and they are active and wide-awake in the conduct of their Grafonola department.

Sterchi Bros.' Furniture Co., which firm conduct a chain of stores in Tennessee and Georgia, and handle locally the Grafonola and the Edison, Mr. Johnson, manager, of the talking machine department, have just closed a most satisfactory month. Mr. Johnson says that in general, considering volume of sales, cash sales, monthly terms and cash business on both phonographs and records, his department is doing finely, and with the hope that in the near future the difficulty in getting stock will be materially lessened, he expects some really big things for the future.

The Stulce-Yarnell Furniture Co., Columbia dealers, exclusively, have been doing for some months past, so Mr. Stulce, the senior member of the firm, says, a highly satisfactory business. Mr. Stulce is enthusiastic over the outlook and is preparing for a record December trade, and is even now laying his plans for 1919.

Rhodes-Mahoney Co., who have the Victrola and the Brunswick lines, are enjoying a well-balanced and satisfactory volume of business. They expect a prosperous holiday trade.



AUTOMATIC STOPS

The simplest and most efficient Automatic Stop on the market. They give excellent service, are easily installed and are absolutely guaranteed.

Send 50 cents for Sample Stop

KIRKMAN ENGINEERING CORPORATION, 237 Lafayette St., New York



VICTORY MUSIC

WILL WELCOME "THE BOYS"

ORDER A FRESH STOCK OF "SMILES" AND THESE OTHER BIG HITS

1101—SMILES, Slow Fox Trot.
Djer Kiss, Waltz.

1074—OH, HOW I HATE TO GET UP IN THE
MORNING.
Good Morning, Mr. Zip, Zip, Zip.

1072—I'M SORRY I MADE YOU CRY.
I Hate to Lose You.

1107—TELL THAT TO THE MARINES, Irving
Kaufman.
Ring Out, Liberty Bell, Sterling Trio.

1096—EVERYTHING IS PEACHES DOWN IN
GEORGIA, Collins and Harlan.
Lovin', Ada Jones.

1110—MY BELGIAN ROSE, Henry Burr.
Dreaming of Home, Sweet Home, Miriam
Fink.

1086—SMILES, Vocal Duet, Ruth Lenox and
Franklin Kent.
Since I Met Wonderful You, Sam Ash.

1073—WHEN YOU COME BACK, Sterling Trio.
Hearts of the World, Chas. Hart.

1108—OH, HOW I WISH I COULD SLEEP UN-
TIL MY DADDY COMES HOME, Henry
Burr.
What a Wonderful Message from Home,
Henry Burr.

1099—THE MISSOURI WALTZ.
I'm Gonna Pin a Medal on the Girl I Left
Behind, Fox Trot.

1106—I AIN'T GOT WEARY YET, Arthur Fields.
K-K-K-Katy, John McDermott.

1112—DEAR OLD PAL OF MINE, George Lam-
bert.
I'm Gonna Pin a Medal on the Girl I Left
Behind, Harry Ellis.

10 Inch Double Discs

Immediate Delivery

Otto Heineman Phonograph Supply Co., Inc.

25 West 45th St., New York



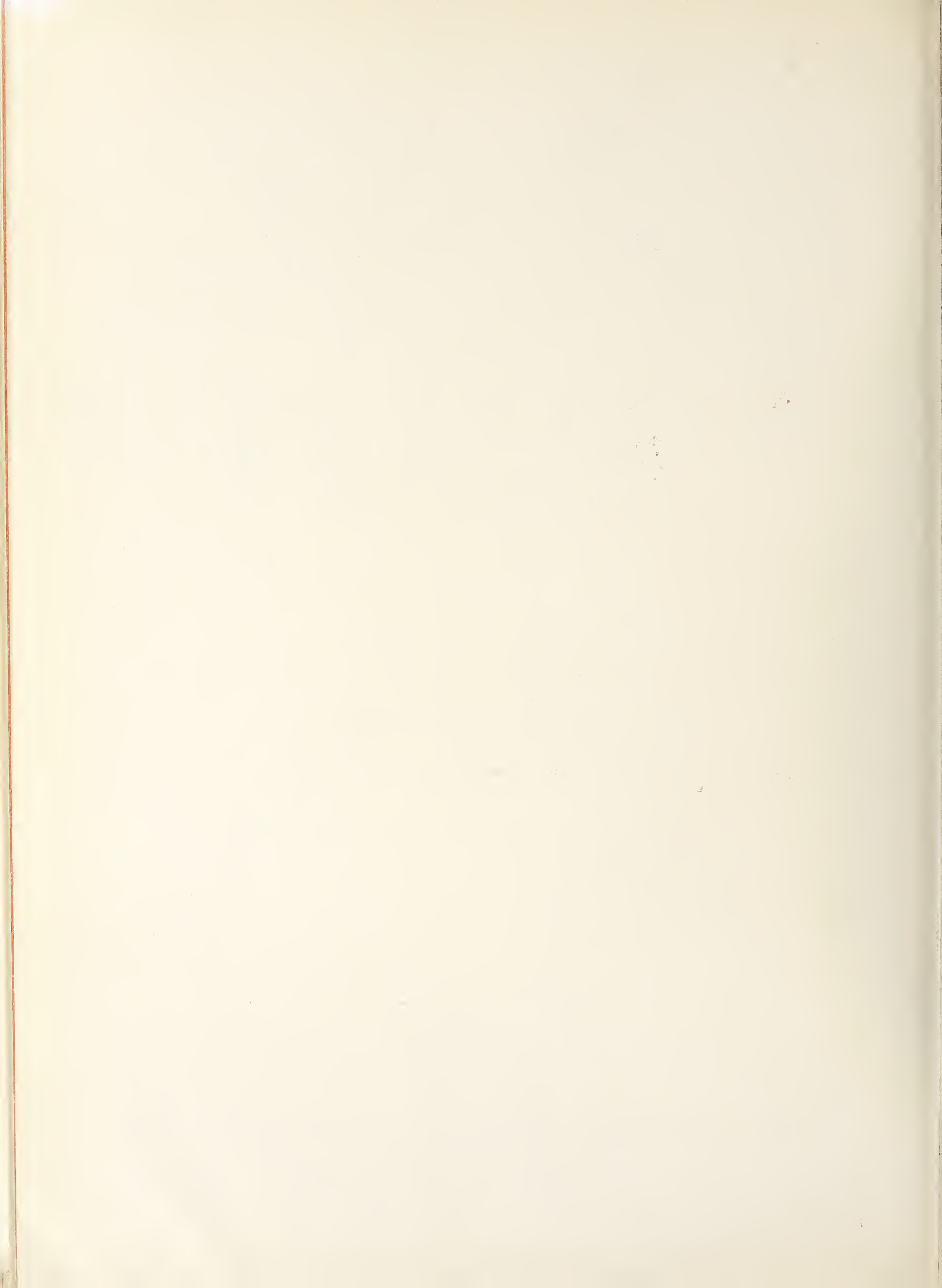

WHO WAS PLAYING HOOKEY WHEN WAR WAS TEACHING?

The Fellow Who Wasn't Paying Attention to the Lesson Has Been Wasting His Tuition Fee and Will Be Sorry When He Grows Up and Finds the Good Students 'Way Ahead

Jed was sitting at his desk pondering deeply over the events of the night before and it was not a grand and glorious feeling. Some days previously he celebrated mildly on the strength of the false report of peace. Then when the real news came he grabbed the spare change out of the till, put the bars up against the shop door and proceeded to show just how sorry he was that Kaiser Bill had yelled "kamerad."

As he sat there, a rather confused mental motion picture passed in front of his mind, the last scene of which showed him calling a big policeman "dearie" and battling hard to pass a night stick barrier in order to kiss the minion of the law fondly on the cheek. Jed had not even shifted his seat on the water wagon for a decade or more, and he had simply celebrated like he handled his talking machine business. The results from a general standpoint were successful. Hence the headache and that "never again" feeling.

When the mental moving picture had ended, however, Jed didn't sit waiting to see the next feature, but started to take stock. The war was over, or practically so, business was in a comparatively short time going to return to a normal peacetime basis, and there he was with a depleted stock, but a surplus of good ideas. Now was the time to figure on the next move.

Jed looked at his bank book, and it was in pretty good shape. He looked at his bills receivable and his list of outstanding instalment paper, and they both represented a negligible quantity, because he had been selling for cash and discounting his bills. Then he looked at his stock, and ye gods what vacancies. "Well," said Jed, "when I seem to be doing fine they sic the war on me. They cut down my stock, soak me with taxes, and boost my cost of living, but I'm still doing business at the same old stand. If I can stick to the ship and come

out clean with a bankroll to boot, with all the cards stacked against me, what can't I do when I get a chance at an even break! Oh, boy.

"I didn't know what selling was until the factories, through necessity, began to give me explanations instead of goods. When my popular stuff got low I just naturally had to go out and sell what I had or stop eating, and I love to eat. Why, man, I learned more about my stock of goods in the last year than I knew after twelve years in the game. There were records I forgot I had that I dug up and praised so loudly I was almost tempted to keep them myself and refuse to sell them. I had to dig out records that hadn't seen the light of day in four years, and urge customers to buy them quick, because they were so popular that they couldn't be supplied fast enough.

"I proved to people who came in to spend a hundred or a hundred and a quarter, and who ordinarily would have gone out with just the machine they came in to buy, that in matters musical they were awful pickers, and what they wanted to do was to tack on a hundred more and get the real machine that I had been saving for them. I boasted this artistic stuff until I got so I believed it myself. They tell us down in Greenwich Village when a short-haired Jane writes a crazy poem that she got the 'urge.' Well, boy, I got the 'urge' to sell the goods that I had; to sell them for cash, because I needed the money, and talked my head off not only to keep the customer from going out of the store clean, but to sell him about twice as much as he came in to buy.

"The old days of waiting for the victim to blow in after he had read the ads for a year or so, and then just take enough time off to wrap up all he insisted on buying, are gone, so far as little Jed is concerned. When I get some more goods at the rate I used to get

them before the war I will raise more dust than a wagon train on the Painted Desert. I'm going to sell some of the stuff I got. After putting out the records I had on my shelves when the bad news broke, and making a living on them, you are going to see me clean up some real money when the limit is taken off. These dollar-down-and-a-dollar-a-week babies don't appeal to me at all any more. I'm not asking a fortune for the goods I sell. In fact, compared with the prices of many other musical instruments, all I request is a little bit of small change, and I'm going to get that small change all at once, or in mighty big lots.

"The last year has been a liberal education to me—an education that has cost me money. I can see myself some months ago looking over my instalment paper and trying to kid myself into the belief that the landlord would take it for the rent. Then I had to learn how to collect on that paper. Now I'm going to collect at the start. It saves trouble.

"Some of the guys in my territory will begin to ease up now. They are going to be so anxious to sell stuff that they will give the customer all the edge he wants. They are going to get back to the old system of letting the manufacturers advertise to bring the customers to the store, and then let the customers sell themselves. Meanwhile, I'm going to sell some stuff. I'm going to get money for it. Then I'm going to tuck away a little bankroll to buy out some of these birds when they hit the skids. I've graduated from one war and I don't want to go back to the same school."

WEGMAN CO. INCORPORATED

The Wegman Talking Machine Co., of Rochester, N. Y., has been incorporated for the purpose of engaging in a general talking machine business by Harry M. and Edward E. Wegman.

The best thing for anyone to say who has nothing to say is to say nothing whatever and then stick to it.

NEW MODEL "B" DUSTOFF Record Cleanser

Beautifully made and finished.

A Money and Trade-Maker for every Talking Machine Dealer.

Keeps the tone of the Record Pure & Clear
A Necessity to all owners of Records



Now Ready for Immediate Delivery

Write for Sample

Name Your Jobber

Jobbers and Distributors Now Handling "DUSTOFFS"

- Atlanta, Ga. Elyea-Austell Co.
- Austin, Tex. The Talking Machine Co. of Texas
- Baltimore, Md. Cohen & Hughes
D. F. Droop & Sons Co.
- Bangor, Me. Andrews Music House Co.
- Birmingham, Ala. Talking Machine Co.
- Boston, Mass. Oliver Ditson Co.
The Eastern Talking Machine Co.
The M. Steiner & Sons Co.
G. T. Williams
- Brooklyn, New York American Talking Machine Co.
- Buffalo, New York W. D. & C. N. Andrews
- Burlington, Vt. American Phonograph Co.
- Chicago, Ill. Lyon & Healy
Chicago Talking Machine Co.
- Cincinnati, O. The Rudolph Wurlitzer Co.
- Cleveland, O. The Collister & Sayle Co.
The Eclipse Musical Co.
The Perry B. Whitst Co.
- Columbus, O. Sanger Bros.
- Dallas, Tex. The Hext Music Co.
- Denver, Colo. The Knight-Campbell Music Co.
- Des Moines, Ia. Mickel Bros. Co.
- Detroit, Mich. Grinnell Bros.
- Elmira, New York Elmira Arms Co.
- El Paso, Tex. W. G. Walz Co.
- Houston, Tex. Thos. Goggan & Bro.
- Indianapolis, Ind. Stewart Talking Machine Co.
- Jacksonville, Fla. Florida Talking Machine Co.

- Kansas City, Mo. J. W. Jenkins' Sons Music Co.
Schmelzer Arms Co.
- Lincoln, Nebr. O. K. Houck Piano Co.
- Little Rock, Ark. O. K. Houck Piano Co.
- Memphis, Tenn. Badger Talking Machine Co.
- Milwaukee, Wis. Berliner Gramophone Co., Ltd.
- Montreal, Canada Price Talking Machine Co.
- Newark, N. J. Emanuel Blout
- New York, N. Y. C. Bruno & Son, Inc.
I. Davega, Jr., Inc.
Charles H. Ditson & Co.
New York Talking Machine Co.
Ormes, Inc.
Silas E. Pearsall Co.
- Omaha, Nebr. A. Hoppe Co.
Mickel Bros. Co.

- Peoria, Ill. Putnam-Page Co., Inc.
- Philadelphia, Pa. Louis Buchn Co., Inc.
C. J. Heppie
Penn Phonograph Co., Inc.
The Talking Machine Co.
H. A. Weymann & Son, Inc.
W. F. Frederick Piano Co.
C. C. Mellor Co., Ltd.
Standard Talking Machine Co.
- Portland, Me. Cressey & Allen, Inc.
- Richmond, Va. W. D. Moses & Co.
- Rochester, N. Y. The Talking Machine Co.
- Salt Lake City, Utah The John Elliott Clark Co.
- San Antonio, Tex. Thos. Goggan & Bros.
- St. Louis, Mo. Koerber-Brenner Music Co.
- St. Paul, Minn. W. J. Dyer & Bro.
- Syracuse, N. Y. W. D. Andrews Co.
- Toledo, O. The Whitney & Currier Co.
- Washington, D. C. Cohen & Hughes
E. F. Droop & Sons Co.
RohL. C. Rogers Co.
- San Francisco, Cal. Walter S. Gray
- Chicago, Ill. The Brunswick-Balke-Collender Co.
Aeolian Co.
- Cincinnati, O. Atms & Doeplke Co.
- Decatur, Ill. Boehman Bros.-Martin Co.
- Kansas City, Mo. Phonograph Co.
- Richmond, Va. Craft Star Phonograph Co.
- Boston, Mass. C. & C. Sales Co.

The New Model "B" Dustoff is made of a high velvet nap, which removes every particle of dust from the minute grooves of the record—mounted on finely finished labeled handle block.
Packed one dozen in counter display cartons.

WM. I. SCHWAB
Manufacturer Minute Shine Products
Providence, R. I., U. S. A.

WILL RESUME THEIR VISITS

Three Members of Pearsall Sales Staff Resume Calls on Trade in Metropolitan Territory

Victor dealers in Metropolitan territory will be glad to learn that after the first of the year three popular members of the sales staff of the Silas E. Pearsall Co., New York, Victor wholesaler, will resume visiting the trade in their former territories. These three travelers, all of whom are popular in the local trade, are S. W. Schoonmaker, Lieut. M. P. Fitzpatrick and C. R. Hutchings.

During the past few months Lieutenant Fitzpatrick has been stationed at Camp Green, N. C.; Mr. Schoonmaker has been filling an important post in a nearby shipbuilding plant, and Mr. Hutchings has been a member of the Army Commissary Department, stationed at Hoboken. They all "did their bit" to help Uncle Sam win the war, and they are now ready to co-operate with and assist Victor dealers in metropolitan territory in making 1919 a banner year.

25,000 SLACKER RECORDS SECURED

Great Collection of Excellent Records Made for Benefit of Fighting Men in St. Louis

St. Louis, Mo., December 3.—About 25,000 slacker records were collected here for the soldiers in the recent drive. At the Kieselhorst Music Co., the headquarters of the drive, it was said that only two records were objectionable because they were German and that only twenty-five or thirty were discarded because they were too much used for further service. The morale of the records, it was stated, was excellent. No estimate was made of the new records received, but a large number came in sealed packages from the various stores that sell such records and a large number of others showed no evidence of use, if the records had been used. During the drive a number of the records were kept on display in the Kieselhorst window and this proved quite an advertisement.

The influence of the "knocker" is growing beautifully less.

ILSLEY'S GRAPHITE PHONO SPRING LUBRICANT

Ilsley's Lubricant makes the Motor make good. Is prepared in the proper consistency, will not run out, dry up, or become sticky or rancid. Remains in its original form indefinitely. Put up in 1, 5, 10, 25 and 50-pound cans for dealers.

This lubricant is also put up in 4-ounce cans to retail at 25 cents each under the trade name of

EUREKA NOISELESS TALKING MACHINE LUBRICANT

Write for special proposition to jobbers.

ILSLEY-DOUBLEDAY & CO., 229-231 Front St., New York

INTRODUCE NEW "BUBBLE BOOK"

Third of This Series Is a Happy Combination of Words, Music and Pictorial Illustrations

In line with the different sales campaigns conducted by the Columbia Co.'s educational



Pages of Third Bubble Book

department, the success achieved by "The Bubble Book" is indicative of the thoroughness of this department's campaign and the practicality of its co-operation with the dealers. While other mediums, such as the Thornton Burgess series of Bedtime Stories on Columbia records, have an appeal to children between the ages of six and twelve, the "Bubble Book" fills the requirements for a medium that reaches the children of kindergarten age or even younger.

The third "Bubble Book" will soon be placed on the market to meet the demand of dealers for another book in this series. In this new book there is a happy combination of words, music and pictorial illustrations. The jingles have been revised by Ralph Mayhew and Burgess Johnson, and there are Mother Goose rhymes with descriptive records that cannot fail to make a favorable appeal to children. The illustrations in "The Bubble Book" are by Rhoda Chase, and are filled with human interest, telling at a glance the story that each record presents.

TOTAL OF 7,085 DEALERS

Now Selling the Brilliantone Line of Talking Machine Needles

Byron R. Forster, president of the Brilliantone Steel Needle Co., New York City, in going over his sales statistics for the past year, found that Brilliantone needles are sold not only in every State in the Union, but in almost every county of every State, and that a total of 7,085 dealers are now selling the Brilliantone line.

VALUE OF ETERNAL VIGILANCE

Ten Minutes' Inspection of a Plant Each Day Will Decrease Fire Loss

Isn't your plant worth enough to you to give it ten minutes of inspection every day? If every business man, every owner of a business or principal in a corporation, gave ten minutes a day to the consideration of inspection against fire loss, how much smaller than \$250,000,000 do you think our annual fire loss figures would be? Would a \$75,000,000 reduction be an extravagant guess? Remember, a \$10 improvement, determined upon as a result of one of these inspections by one of these principals, might save a loss of \$1,000,000 in one fire, and a general adoption of the system very likely might prevent several million-dollar fires each year. Are we overestimating the value of eternal vigilance? asks the Credit Man's Bulletin. Has any man ever overestimated it?

FAULTLESS CASTERS



The Weight Rests Here



Full Size
C-16-5

Perfect construction and inviting in appearance—
FAULTLESS Casters are still more pleasing in actual use, in moving phonographs.

Their gentle, easy moving qualities are most essential and agreeable.

Send for Samples

*"Move the **FAULTLESS** Way"*

FAULTLESS CASTER COMPANY
Evansville, Indiana

BUFFALO LOOKS FOR INCREASE OF PROSPERITY IN 1919

Members of the Talking Machine Trade, Irrespective of Line Handled, Are Most Optimistic Regarding the Future—Christmas Trade Promises Well But Shortage of Machines Hurts

BUFFALO, N. Y., December 8.—Buffalo's talking machine dealers are of the opinion that they will enjoy a larger measure of prosperity in 1919 than they had during the past year. There are no signs of pessimism in the trade. During the present "reconstruction period," following the ending of the world-war, a new source of patronage is that of conservative citizens who delayed the purchase of talking machines until peace had been declared. Now that strict, wartime economy is no longer urgent, this class of customers is ready to make substantial down payments and pay their monthly amounts promptly. The sale of talking machines for gift purposes is in full swing. At the request of the Buffalo Retail Merchants' Association, of which some of the talking machine dealers are members, Christmas trade began more than a month earlier this season than was the custom in former years.

The propaganda had the backing of the Council of National Defense. Even if many talking machines, intended as Christmas presents, were bought in November and early this month, it is expected that there will be no let-up in the business right up to the Yuletide holiday.

"Business is very fine and everything that comes in is sold as soon as we get it," said F. A. Denison, manager of the local Columbia branch. "We have many thousand dollars' worth of unfilled orders."

Marion Dorian, chief auditor of the company, paid a two-days' visit to the local branch. C. M. Wall, road representative, has recovered from an attack of the "flu" and is again calling on his customers.

B. E. Neal, of Neal, Clark & Neal, was chairman of the "musical instrument division" in the United War Workers' campaign. This section "went over the top," its quota being \$7,500.

Talking machine records referring to such im-

portant topics as peace, victory and the home are in demand here.

As most of the local industrial plants are keeping up production at full speed, factory workers and others continue to spend liberally at the talking machine stores. Most of the plants are now turning their attention to the making of products which they featured before the war. It will be some time before they fill their accumulation of orders so that most of their employes may be retained in their present positions indefinitely. No industrial upheaval therefore is in sight.

Charles Kellogg, nature singer, who makes records for the Victor Co., was a recent visitor.

A heavy trade in talking machines and records was a feature at the local stores during Thanksgiving week. Even reports that high-salaried jobs during the "reconstruction period" may not be so plentiful as they have been in the past year did not deter the factory and other workers from offering worth-while patronage to the stores. The ending of the war gave a special impetus to this year's Thanksgiving celebration and the expectations of the talking machine merchants that Thanksgiving trade would be excellent were fully justified. Many Canadian men, who during the war were not permitted to cross the border on account of Dominion draft regulations, celebrated Thanksgiving and the day previous here. The presence of considerable Canadian money at the local stores proved that the visitors bought many records.

Twenty-five teams recently canvassed Lockport, N. Y., for talking machine records for soldiers. In the first day of their campaign they received 1,150 records and some talking machines.

A. F. Koenig, of the Koenig Piano Co., who handles the Pathé line, reports that his trade

last month was four times that of November last year.

C. N. Andrews, of W. D. & C. N. Andrews, recently visited the Victor factory. His trip also included New York and Washington.

Pathéphones are played up prominently in the extensive holiday stock of Victor & Co.

William Henry Hotchkiss, a wealthy Buf-falonian, died at his home here recently. He was one of the former owners of J. N. Adam & Co.'s department store, which has a complete Victrola section.

LIVE NEW BOOK FOR BUSINESS MAN

"How to Handle and Develop Your Own Business" Just Published by A. W. Shaw Co.

A book that should prove of great value, particularly during the after-war period, and with business development the topic of the hour, has just been issued by the A. W. Shaw Co., Chicago, under the title "How to Handle and Develop Your Own Business." The 140-odd pages of the book are filled with valuable ideas and suggestions tending to simplify and improve business methods generally; ideas that have proven successful through actual application. There are charts showing how to handle accounts; how to lay out the work of the day; classify credit ratings; make collections, and also how to advertise most effectively. Some valuable hints are given as to selling methods, with a view to eliminating waste time and effort, and what is perhaps the most interesting chapter in the volume is entitled "How to Make Your Banker See It Your Way." It is a book worthy of a resting place on the desk of any business man, and should have a wide circulation among those who are interested in improving their business methods.

He is a fortunate man who can find the difference between being high-minded and being stuck-up, and then make the proper use of that difference.

ANNOUNCEMENT

Emerson Record Sales Company^{INC.}

366 Fifth Avenue, New York

has been appointed distributors for the metropolitan district for

Emerson Gold Seal Records

(LARGE SIZE)

The company is organized for efficient and prompt service and will carry a substantial stock of all releases for immediate delivery.

Now on Hand at Our Offices



- | | | | |
|-----|---|-----|--|
| 997 | { Oh! How I Wish I Could Sleep. Patriotic Ballad.....Henry Burr
Watch, Hope and Wait, Little Girl. Tenor Duet.....Gordon and Bruce | 982 | { Smiles. Baritone Solo...George Beaver
You Keep Sending 'Em Over. Patriotic Solo.....Eddie Nelson |
| 995 | { Tell That to the Marines. Baritone Solo.....Irving Kaufman
Why Do They Call Them Babies. Contralto Solo.....Edith King | 979 | { When You Come Back, and You Will Come Back (Geo. M. Cohan), Eddie Nelson
When I Get's Out in No-Man's Land. Character Song.....Arthur Collins |



"The Quality Phonograph"

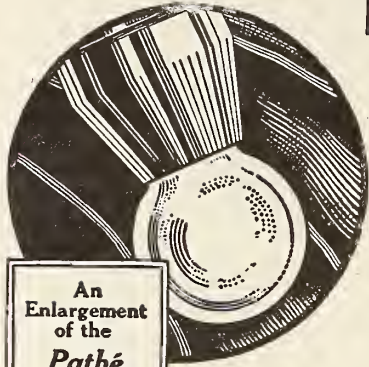

An Enlargement of the Pathé Sapphire Ball and Pathé Record Grooves

The best selling point is better than ever today!

EVER since its origin, the Pathe Sapphire Ball has been the best phonograph selling point for the dealer. Because it is *exclusive*, permanent—does away with needle changing altogether—produces pure natural tone and gives long life to records.

Today, with needles rising in price by the minute and rapidly disappearing from the market, this big exclusive Pathe feature is not alone a better selling point than ever before. It insures the dealers against a possible future stoppage of his phonograph sales.

Right now, when we can assure you immediate and full deliveries of Pathe Phonographs, get in your orders.

Do you know what "The Other 20%" is? Write for book "The Other 20%" and it will tell you plainly and convincingly.

Pathé Frères Phonograph Company
20 Grand Avenue Brooklyn, N. Y.

The Pathé Frères Phonograph Co. of Canada, Ltd., Toronto

No Needles to Change

The Pathé Sapphire Ball takes the place of needles. It need not be changed.

Long Life to Records

(Pathé Guarantee)

We guarantee every Pathé Record to play at least *one thousand times* with the Pathé Sapphire Ball, without impairment to the unexcelled beauty of tone and without showing any perceptible wear on the record.

The Pathé Controla

With the Pathé Controla you may increase or decrease the tonal volume of the Pathé Phonograph at will.

Plays All Records

Each Pathé Phonograph plays not only Pathé Records, but all other makes of records, and plays them perfectly.



Sheraton Model

Satin Mahogany Finish
\$215

Other Models \$32.50 to \$1000



MURATORE

Principal Tenor
Chicago Opera Company



"The Quality Records"

At Least one thousand times

"What! *Guaranteed* Records?"

Well, that certainly means "easier to sell" Records, doesn't it?

Especially when—

It further means the latest American music before out on other records and a complete selection of the "old world's" music never out on other records.



ALL MURATORE'S Records are Pathe Records

Read the Pathé Guarantee :

"We guarantee every Pathe Record to play at least *one thousand times* with the Pathe Sapphire Ball, without impairment to the unexcelled beauty of tone and without showing any perceptible wear on the record."

And don't miss any more of the sales this Guarantee alone makes for the dealer. Write for Pathé Dealer's proposition today!

Pathé Frères Phonograph Company

20 Grand Avenue

Brooklyn, N. Y.

The Pathé Frères Phonograph Co. of Canada, Ltd., Toronto



An Enlargement of the **Pathé Sapphire Ball** and Pathé Record Grooves

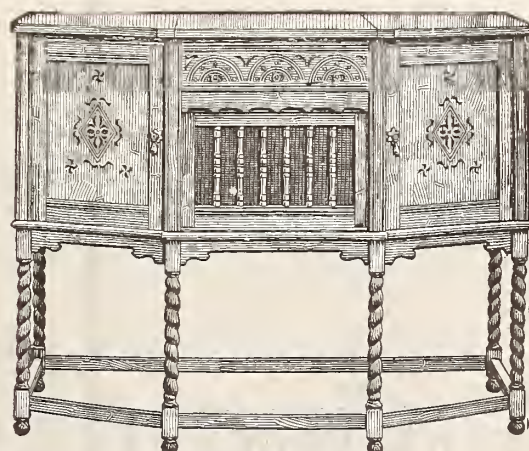

Jacobean Model



"O Sole Mio"—the greatest Neapolitan folk song; and Stracciari sings it on Columbia Record No. 78097.

**Columbia Graphophone Co.
NEW YORK**

NEW DISTRIBUTING FACTORS

The Emerson Record Sales Co., Inc., Will Act as Distributors in Metropolitan Territory for the Large Sized Emerson Records

Announcement has been made that in the future, Emerson large size records will be distributed in the metropolitan district through the Emerson Record Sales Co., Inc., with offices at 366 Fifth avenue, corner of Thirty-fourth street, New York. This arrangement has been made in order to effect important improvements in service for the dealers of the district.

The central location of the distributing offices will assist materially in the quick distribution of the popular hits immediately after they are released. A special telephone service has been installed in order to handle this important branch of the business, and several of the salesmen formerly visiting the trade in local territory for the Emerson Phonograph Co. have been transferred to the Emerson Record Sales Co. The Emerson Record Sales Co. will handle exclusively in local territory Emerson large size seventy-five cent records.

In a chat this week with *The World*, H. T. Leeming, vice-president and general manager of the Emerson Phonograph Co., stated that negotiations are now pending in Boston, Chicago and other important territory with the view of establishing distributors so that the dealers at all times will have the least possible delay in getting their goods in a satisfactory quantity.

RAIMUND WURLITZER AN ENSIGN

Son of Howard E. Wurlitzer Receives His Commission as Naval Officer

Raimund Wurlitzer recently received his commission as an ensign in the United States Navy. He expects to pursue the maritime life as an officer in the navy for the next four years, and before setting out on the high seas has been spending a furlough at the home of his father, Howard E. Wurlitzer, head of the Rudolph Wurlitzer Co., Cincinnati, O.

Previous to enlisting in the navy Raimund Wurlitzer was a student at the University of Wisconsin. He has been stationed at Newport, and at the Naval Training Station at Pelham Bay, where he finally completed the by no means simple task of rising from the ranks to the position of ensign.

A certificate of incorporation has been issued to the Phonograph Atelier, Inc., by the Secretary of State at Wilmington, Del., for the purpose of manufacturing talking machine records. The capitalization is \$15,000.

COTTON FLOCKS

.. FOR ..

Record Manufacturing

THE PECKHAM MFG. CO., 238 South Street
NEWARK, N. J.

VICTOR TALKING MACHINE CO. ISSUES THIRD STATEMENT

Prospects for Rapid Resumption of Pre-War Conditions Outlined in Interesting Statement Made Public Last Week—Reduction of Government Restrictions Will Aid Trade

Under date of November 16, 1918, the Victor Talking Machine Co., Camden, N. J., issued the following statement to the trade:

"On October 30, the date under which our War Statement No. 2 was mailed, it hardly seemed possible that two weeks thereafter the restrictions enumerated therein would be modified to the great advantage of the entire trade.

"However, since the glorious victories of the Allied armies, which culminated on Monday morning with the signing of the armistice, the Priorities Commissioner of the War Industries Board has addressed to the War Service Committee of the Talking Machine Industry the following telegram:

"Account favorable war developments restrictions on Talking Machine Industry, including motors and accessories embodied in circular No. 39, Priorities Division, are hereby so modified that for last four months of 1918 the consumption by said industry of iron, steel, copper, brass and aluminum used in the manufacture of its products will be on basis of not exceeding 70 per cent., or four-twelfths of its 1917 consumption instead of 40 per cent., as provided in said circular. In all other respects rules and regulations remain in full force and effect. Please notify at once all the members of your industry."

"While the above modifying order does not remove all restrictions nor permit of an immediate return to operation at full capacity, it is quite positive evidence that the officials of the War Industries Board are keenly alive to the commercial interests of the country, and realize the necessity and justice of as early a return as possible to normal conditions.

"The trade will realize there are many readjustments that must be made to meet the new conditions, but you may be assured that taking all things into consideration, our return to quantity production will be as rapid as the circumstances will permit. In the meantime, we ask all those who have shared with us our war responsibilities to be as patient as possible with the realization that their future prosperity will recompense in full for the past shortage of Victor product.

"Congratulating the trade in the sacrifices they have made to help win the war, and sharing with you the happiness of our complete victory, we are, yours very truly,

"VICTOR TALKING MACHINE Co.,
"Louis F. Geissler, General Manager."

System—that's a word to remember and tack over the door of any business enterprise so that every employe may see it.



It's a Pretty Good Idea to always keep in mind the fact that a



SCHUBERT PHONOGRAPH

will bear the closest inspection; its particular qualities warrant investigation, and hundreds of friends everywhere loudly extol its superiority.

SIX MODELS \$60.00 UP

**SCHUBERT
RECORDS**

A \$30 investment starts you with complete, up-to-date list of Popular, Vocal and Instrumental selections; 20 to 30 new selections monthly; 10-Inch Double Disc. Write for details.



The BELL TALKING MACHINE CORPORATION

Offices and Show Rooms:
44 West 37th Street, New York

Factory:
85 Southern Boulevard, Bronx, New York

Export Department, 498-504 Broadway, New York, N. Y., E. U. A.
Smith-Woodward Piano Co., 1018 Capitol Ave., Houston, Tex., Local Distributor
Special Australian Representative, B. LESCHHAU, 350-2 Flinders Lane, Melbourne

Happenings in Dominion of Canada

PEACE CHRISTMAS IN MONTREAL TO BE DULY CELEBRATED

Already There Is Evidence of Large Purchases of Talking Machines for Gifts—The Trade as a Whole Most Optimistic Regarding the New Year and Rejoice That Restrictions Are at an End

THE SPIRIT OF CHRISTMAS

I am thinking of you to-day because it is Christmas, and I wish you happiness. And tomorrow, because it will be the day after Christmas, I shall wish you happiness; and so on through the year. I may not be able to tell you about it every day, because I may be far away; or because both of us may be very busy. But it makes no difference. The thought and the wish will be here just the same. Whatever joy or success comes to you will make me glad. Without pretense and in plain words, goodwill to you is what I mean in the spirit of Christmas.

HENRY VAN DYKE.

MONTREAL, CAN., December 8.—A number of dealers have planned for larger stocks, which is substantial evidence of their confidence in business conditions generally, as well as their faith in the future of the talking machine trade. On account of war times many a person has often held back their natural inclination to give something in keeping with war conditions and now with an equal regard for the fitness of things they instinctively turn to something that shall adequately commemorate what will be known as the "Peace Christmas." No doubt phonographs and pianos will be included as gifts which are not only lasting but ones worthy of the occasion.

Miss Vezina, in charge of Almy's Limited Grafonola departments, reports an exceptionally heavy volume of cash business with a spirited call for individual cabinets in golden oak and mahogany.

Geo. Davies, advertising manager of the Berliner Gramophone Co., Ltd., has relinquished that position for that of purchasing agent of the company and has been replaced by J. B. West. A. C. Skinner, Sherbrooke, Que., has taken the representation of the Columbia Grafonola and Columbia records.

H. S. Berliner, vice-president of the Berliner Gram-O-Phone Co., Ltd., subscribed personally \$60,000 to the Victory Loan.

The visit of Hipolito Lazaro, the Spanish tenor and exclusive Columbia artist, had a marked effect on the sale of Columbia records of the noted artist's productions. All Columbia dealers report a heavy run of purchases prior to and subsequent to his recital.

In the recent Victory Loan drive the keenest competition existed among the workers in the various Montreal plants to win the honor flag which was distributed by the employes committee of the Victory Loan. Among the companies which exceeded their quota and were entitled to the Governor General's honor flag was the Berliner Gram-O-Phone Co., Ltd., and C. W. Lindsay, Ltd.

The Berlind Phonograph Co. have incorporated as a limited liability company. This firm report Brunswick business as splendid for the past month and are looking forward to an extra large volume of holiday trade.

Alex Comotois has registered as a dealer in talking machines, etc.

Leon Coemen has opened up Pathé parlors at 211 Sherbrooke street West, where he intends featuring the Pathéphone and Pathé records.

J. N. Archambault, 949 St. Denis street, is making a leader of the Pathéphone and is stocking Pathé records in a large variety of numbers.

So great has been the demand for Sonora and Columbia machines that C. W. Lindsay, Ltd., have had to draw from the stock of their various branches to meet the call for these makes in order to fill local orders.

"Wholesale business with the Canadian Graphophone Co. in Columbia products," said Manager Depocas, "is observingly good and we

are well pleased with the orders on hand. With the declaration of peace we anticipate an immense demand for holiday goods which should prove a big stimulus to the trade inasmuch as 'Music in the Home' will be the real thing this Xmas to those who have relatives returning from the front."

"Victor machines of various models together with Victor records have been in splendid vogue the past thirty days," said J. Donat Langelier, "and we are already laying aside numerous models chosen as Christmas gifts to be delivered Xmas eve."

Charles Curloss told your correspondent that trade could not be better and remarked that everything is bristling with success. The orders on his books showed a substantial increase over the corresponding period of last year. Sonora and Aeolian-Vocalion machines are going big.

N. G. Valiquette, Ltd., reported sales and inquiries as never better, the demand for the Pathéphone and Pathé records keeping up and increasing daily.

TORONTO DEALER ON EDUCATIONAL VALUE OF TALKER

Recent Talk by W. Mason on "Making Sales Outside the Store" of Interest—Toronto Phonograph Shop Opens New Parlors—Dealers in This Territory Pleased at Ending of War

TORONTO, ONT., December 8.—"I consider the man or woman who is engaged in selling musical instruments should feel that his or her position is just as honorable as any of the great professions or the great missionaries, as we are always trying to place an instrument in homes for the education of the young and the pleasure of the old," said W. Mason, manager of the Lindsay branch of the J. M. Greene Music Co., Ltd., Peterboro, Ont., at the convention of Canadian Edison dealers held in Toronto recently.

Mr. Mason, who was on the program for a talk on "Making Sales Outside the Store," quoted Rev. E. van Tilton, now of Lindsay and formerly pastor of one of Vancouver's largest Methodist churches, who, in a sermon in August, 1918, said that he thought that there should be a phonograph and piano in every school and public library and a teacher paid by the municipality so that the children of the poor could have the advantage of music. Telling of his sales methods he said in part: "In selling on the outside, I think the first and most important thing is to make the very best of our position. The next very important part, in my mind, is a pleasant good-morning for both rich and poor. Where you are meeting the same people almost every day, it goes a long way in helping to sell an instrument when you call at their homes.

"Another point is not to get sore if you put an Edison Disc in a home and have to take it out without making a sale. I had to do this about three years ago. This man later bought another make and comes to us occasionally for

The Berliner Gram-O-Phone Co., Ltd., have experienced a great rush of business during the past month in all of their retail stores, preference being given in most instances to the larger and more expensive cabinet models, whilst goodly prominence as usual has been due Victor records.

Dupuis Freres (Miss Didier) opine that this year's holiday trade will eclipse anything in the previous history of the talking machine industry and in this regard she anticipates getting her full share of prosperity in the sale of Pathé-phones and Pathé records.

"Pathé Growth proves Pathé Quality," said Manager Geo. S. Pequegnat of the Phonograph Shop of this city and the large demand testifies to Pathé Quality. Aeolian-Vocalions are also well represented in sales by this house during November, and have started off well for this month.

Tom Cowan, of the Cowan Piano and Music Co., is enthusiastic over his Brunswick sales for November.

"'Busy' is the word that best expresses our voice for the past month's business," said Mr. Gagnier, of the Canadian Graphophone and Piano Co., who represents Columbia Grafonolas and records.

records. We always used him nicely, and I always met him with a good-morning. Last week I sold this same man a player-piano for almost cash. I also sold this month a William and Mary model to a party in whose home I had a C-250 two years ago, but could not sell at that time.

"Occasionally we go to the country and we do not always find the lady good natured. I had this experience some time ago. I had sold a country merchant a new Edison and he told me to call on this party. Of course, this I was glad to do. The lady nearly ordered me off the farm and said she thought the merchant had more sense than to pay that price for a talking machine. I asked her to go in and hear the merchant's Edison the first time she went to the store. I told her she would want one like it. This she soon did and today these people are among our greatest boosters.

"On another occasion I was asked by the management of the Presbyterian Church if I would furnish the music for an informal reception for new members who had recently moved to town. I went with this instrument myself, got acquainted with a number of people I did not know before and sold the wife of the sheriff a C-200 model. We have found that demonstrations in the home, at entertainments and church and society gatherings are excellent opportunities to get to the attention of the public."

All local dealers are practically a unit in declaring that this season's holiday business

(Continued on page 34)

Talking Machine Supplies and Repair Parts

SPRINGS, SOUND BOX PARTS, NEEDLES

THE RENÉ MANUFACTURING CO.
MONTVALE, NEW JERSEY



What are you doing with the List of Christmas Records? It's full of good sales suggestions. Look it over.

**Columbia Graphophone Co.
NEW YORK**

TRADE CONDITIONS IN CANADA

(Continued from page 33)

should eclipse all former years. It is expected that a large number of men from the front will reach Canada in time to spend Xmas at their own fireside and this is one of the reasons advanced that the sale of talking machines and records will soar high in volume of business to be closed.

Mahood Bros., His Master's Voice dealers in Kingston, Ont., the day the armistice was announced ran good-sized copy in the local dailies advocating the purchase of patriotic Victor records to commemorate the victory.

Victor dealers all over the country report a splendid demand for Ho Frenchy both in vocal, instrumental and otherwise.

The Toronto Phonograph Shop, 123 Yonge street, Toronto, has opened up new music parlors and is featuring the Pathéphone and Pathé records and a complete line of gold medal phonographs, a new Canadian made instrument.

TRADE NEWS FROM EDMONTON

Hudson Bay Co. Secure Representation of Pathéphone—Reed & Robinson Expansion

EDMONTON, ALTA., December 5.—The Hudson's Bay Co., of this city, announce that they have further increased the facilities of this store and have extended the Hudson's Bay service to their patrons by the addition of a well equipped talking machine department. They have secured the representation of the Pathéphone and are carrying a complete line of models as well as Pathé records. They have been appointed sole licensees for Edmonton. Impressive large-

sized copy has appeared in all the local newspapers announcing the opening of their exclusive Pathéphone parlors.

Reed & Robinson, of this city, are making preparations to extend their talking machine department to include a number of soundproof booths so that customers may listen to Brunswick phonographs in quietness and comfort in these comfortable quarters.

The Lodge Piano House, of Edmonton, has taken the representation of the Gerhard Heintzman phonograph. A heavy demand for Victor records is reported by this house. The sales include both popular and patriotic records.

The third prize in the Winnipeg Telegram want advertisement contest consists of a Columbia Grafonola and twenty-five records purchased from Stanwood's, Ltd., of that city.

CLIFFORD R. ELY'S NEW POST

Has Become a Member of the Wholesale Pathé Traveling Force

Announcement has been made that Clifford R. Ely, one of the best-known members of the wholesale traveling fraternity, has joined the Pathé traveling forces and will visit the trade throughout the country. For many years Mr. Ely was a member of the Columbia traveling staff and he numbers among his personal friends dealers from coast to coast. As a Pathé wholesale travel-



C. R. Ely

er Mr. Ely's long and successful acquaintance with the industry will be utilized to excellent advantage, as he is in a position to render Pathé dealers efficient service and co-operation.

NEW AUSTRALIAN CUSTOMS RULES

Exporters making shipments to Australia should prepare immediately to comply with the requirements concerning invoices and customs declarations which go into force on January 1, 1919. After that date all invoices for goods dutiable at an ad valorem rate of duty from all countries other than China and Japan must contain a separate column showing the fair market value for home consumption in the country of export, at the date of invoicing to Australia, of similar goods in similar quantities.

"THE SUCCESSFUL SALESMAN"

This Is the Title of a New Volume by Frank Farrington Which Is of Exceeding Merit

A most excellent and interesting new book on salesmanship entitled "The Successful Salesman," by Frank Farrington, has just been published by Laird & Lee, Inc., Chicago. There have, of course, been other books on salesmanship—too many of them by theorists whose profession was writing and not selling. Mr. Farrington, however, in his latest volume shows an accurate knowledge of the science of salesmanship, based on actual experience, and offers much material of practical value.

It may be that salesmen are born and not made, but even the born salesman can find much material in Mr. Farrington's new book that will make his selling easy.

Mr. Farrington is a recognized authority, and his name is familiar to many trade journal readers and business men generally as the author of numerous books and articles on selling, advertising, store management, etc. Some of the thirty-two chapters are: "What Makes a Salesman?"; "Salesman and Salary"; "Understanding the Customer"; "What Customers Want"; "Showing the Goods"; "Putting Punch Into Salesmanship"; "The Morning After"; "The Salesman and the Catalog"; "The Value of System"; "It Can't Be Done"; "The Art of Selling Yourself." The price of the book is \$1 net.

CONTAINED VALUABLE SUGGESTIONS

J. I. Carroll, Emerson sales manager, has received many interesting letters from the dealers throughout the country referring to the excellent article written by him for the November issue of The World entitled, "Keeping Good Help Should Be a Prime Consideration With the Live Dealers." These dealers informed Mr. Carroll that his article contained valuable suggestions that they are utilizing in their own establishments.

H. L. WILLSON ONE OF THE GUESTS

H. L. Willson, general manager of the Columbia Graphophone Co., was one of the prominent guests at the luncheon of the American Manufacturers' Export Association at the McAlpin Hotel, New York, the other day, when an address was made by the Italian Ambassador inviting American capital and enterprise to center attention on Italy in connection with the development of export trade.

The Mutual
TONE ARMS & SOUND BOXES

Dealers

**If you want the best,
be sure that the machines you handle
are equipped with**

MUTUAL

**TONE ARMS AND
SOUND BOXES**

Mutual Talking Machine Co., Inc.

145 West 45th Street, New York

WESTERN VENEER PRODUCTS CO.
3900 CHOUTEAU AVENUE, ST. LOUIS, MO.

**Largest Manufacturers of 3-ply
Veneer Phonograph Shipping Cases**

Ask for Prices and Samples

THE INSTRUMENT OF QUALITY

Sonora

CLEAR AS A BELL



Semi-Permanent, Silvered Needles

THESE new needles fill a long felt want and are so superior that, once tried, they will be used permanently, because of their

- 1 *Improved Tone:* They mellow the tone and eliminate harshness.
- 2 *Greater Economy:* They play 50 to 100 times before wearing out, and outlast any other multi-playing needle.
- 3 *Increasing Life of Records:* The record engaging point does not enlarge as it wears, having the same diameter throughout.
- 4 *Convenience:* They save constant needle changing.

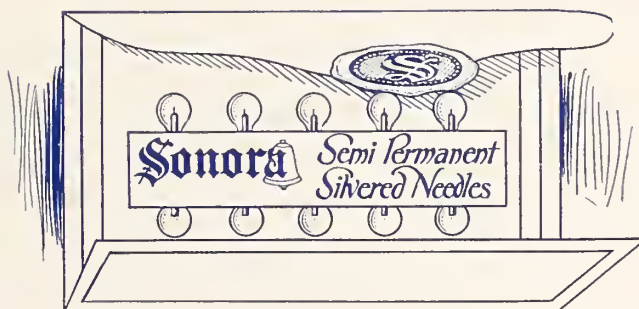

Three Grades
LOUD MEDIUM SOFT

30c. for package of FIVE

Sonora needle sales run into volume quickly, and it will pay you to handle this splendid product which is meeting with popular favor.

Suitable matter describing this needle will be forwarded on request. **Send in your order today for sample shipment.**

Sonora Phonograph Sales Co., Inc.

GEORGE E. BRIGHTSON, President

Executive Offices: 279 Broadway, New York

Demonstration Salons: NEW YORK: Fifth Avenue, at 53rd Street
PHILADELPHIA: 1311 Walnut Street

50 Broadway (Standard Arcade)
TORONTO: Ryrie Building

Export Department: 417 West 28th Street, New York

CAUTION: Beware of similarly constructed needles inferior in quality!



Sonora Phonograph Sales Company, Inc.

GEO. E. BRIGHTSON, PRES.

279-281 BROADWAY

NEW YORK

To the Phonograph Dealers of America:



WITH the coming of Peace, America is entering the greatest period of activity and prosperity in its history.

That part of the public which held up its purchases of phonographs during war time is ready to buy now. The year 1919 will undoubtedly see all phonograph sales records broken and it is at the beginning of this new reconstruction era that we wish to state that the *Sonora will demonstrate its supremacy even more convincingly in the future than in the past.*

Setting the highest of standards, maintaining a wonderful quality and improving its already magnificent tone, the new Sonora will continue firmly to uphold its reputation as being **The Highest Class Talking Machine in the World.**

With the government restrictions lightened we anticipate a large increase in production and excellent deliveries.

Our hearty greetings and best wishes are extended to you, this most joyful of all Christmases.

Sincerely yours,

SONORA PHONOGRAPH SALES CO., INC.

GEORGE E. BRIGHTSON, *President*

TWIN CITIES EXPERIENCING FAMINE IN TALKING MACHINES

Jobbers Have Immense Orders on Books Which They Are Unable to Fill—More Hopeful Now That Peace Has Arrived—Foster & Waldo Secure Sonora Agency—What Leading Jobbers Report

ST. PAUL and MINNEAPOLIS, MINN., December 5. —Writers on talking machine subjects will hail the reincarnation of Noah Webster or the birth of a new lexicographer. We need some synonyms for "famine," "shortage," "dearth," "inability to obtain," "lack of" and other words and phrases meaning that it is difficult to fill orders. Such words have been so used over and over again in attempting to depict the plight of the talking machine dealers of Minneapolis and St. Paul that they become meaningless and some new phrases must be coined very soon or some critic will remark that we lack originality and imagination.

Well, as has been noted in these columns for thirty-six consecutive months, the only limit to the talking machine trade in the great Northwest is the ability of the dealers to obtain goods—both instruments and records. It must be that they are without ability, for they are obtaining neither.

"We have orders for about 3,000 Victrolas on our books," remarked W. J. Dyer, with a beaming smile. "We hope to fill the orders, but my personal conviction is that quite a number of Northwestern dealers will be disappointed. Some would say that the present situation is much more desirable than to get tied up with a surplus of 3,000 machines.

"Well, if that is any consolation, we must make the best of it, for that is all the consolation there is, except that Dyer & Bro. are shattering all their former records for Victrola sales. Our young men are coming back from the war and this is lifting some anxiety from our burden of cares."

A prominent phonograph dealer in the twin cities is somewhat envious and at the same time somewhat resentful over a scheme played by a contemporary dealer. The latter, it is averred, was interested in a number of houses, which nominally were operated as independent concerns, but as a matter of fact were branch houses. Excessive orders were sent in from all branch houses and while the orders only were partially filled, the head house had quite a stock to draw from, thereby placing all competitors at some disadvantage. No, it is impossible to divulge any names—it wouldn't be polite.

"We could place 1,000 machines next Monday could we get them," declared E. L. Kern, director of the Brunswick-Balke-Collender Co., manufacturers and distributors of the Brunswick phonographs. "We have been getting some machines, but certain popular styles are not easy to get."

R. N. Cardozo & Bro., one of the oldest furniture houses in the city of St. Paul, has taken on the Brunswick line and expects to push it with much vigor. Boutell Brothers in Minneapolis are making a distinct success with their Brunswick business, and at the present rate of progress soon will be distributing a carload a week in a straight retail way. Style 35 is proving a fine seller.

There are two Cheney shops in the Twin Cities, one in each twin. The managers express themselves as fully satisfied with the results of their efforts. They have obtained, they

believe, a firm foothold in the face of keen competition and already may be said to be on a profitable basis. Earl C. May, general manager of the Cheney interests, finds time to get up into these parts about once a month and help in spreading propaganda for his wares.

Orders for Pathé machines and records are coming over the long distance telephone lines to G. Sommers & Co., St. Paul, distributors for the Northwest. Jay H. Wheeler, in charge of the Pathé interests, testifies that he has all that he can do to fill orders. The home factory must turn out a greater number of the No. 7 and No. 12 models priced at \$95 and \$140, or some desirable business will be lost. Already these models are scarce. The record racks with a capacity approaching 200,000 are losing their contents quite rapidly.

Even the sample models in the Columbia headquarters in Minneapolis have had to go in order to supply the incessant demand for instruments. There is not a single instrument between the \$47 and the \$750 models on the floor, and Manager Sprague is due for a brain storm if the machines don't come presto.

W. E. Smith, head of the Dictaphone branch, returned last week from a staff meeting in New York. The November sales record tops all monthly records since the machine entered the Northwestern territory.

Foster & Waldo have added the Sonora line of machines to their stock and now handle four makes of talking machines. The house began some years ago with the Victor line, then added the Edison. Later it was found necessary to take on the Columbia line in order that patrons should not be disappointed. Even with three factories to supply instruments the demand remained unsatisfied, and hence the classy Sonora machines were placed on the Foster & Waldo floors.

It is wholly impossible for the Victor jobbers in the Twin City territory to even approximate the demand for machines and records. W. J. Dyer & Bro., St. Paul, report that they have on hand orders for 3,000 machines. Whether they will be able to fill them or not is a matter of mere speculation. Beckwith-O'Neill Co., Minneapolis, never have been in such straits as they are now.

MORE THAN A HINT HERE

Army life is not only developing our young men physically, but the mental side gets attention, too. There is a series of what are known as "nut" tests, in which many surprising and freak questions are asked for the purpose of determining quickness of wit, mental balance, logical reasoning, etc. There is more than a hint in this for the industrial world.

One of two editors in a town who had always slandered one another in their newspapers died one day in a bathtub. The other, endeavoring to curb his pen as he wrote the report of the death, contented himself by saying that his colleague came to his death "while trying an experiment."

The Scotford Tonearm and Superior Universal Reproducer

The Ideal Combination

Plays All Makes of Records as they should be played

Price of Sample Prepaid
Nickel, \$5.25 Gold, \$6.50

Adjusted for Cabinet measuring 8 1/2 inches from center of Tonearm base to center of Turntable shaft

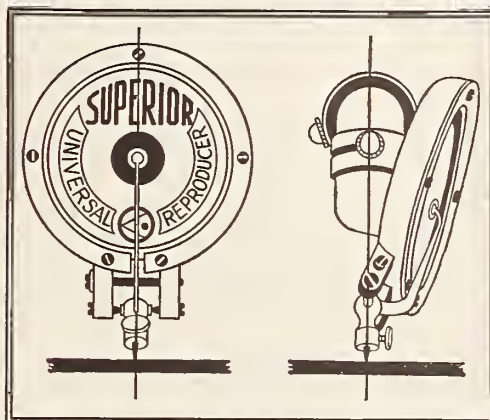

Distinctive Features

The Reproducer pivots on its axis (as illustrated above), taking the correct angle for all makes of records, and the needle retains same center in both positions.

Surface noise is less than with any other reproducer—surface scratchings being reduced to a minimum through perfect proportioning of the stylus construction, and placing the needle in the center of the groove at the correct angle.

The split construction of the frame and face ring of the Reproducer, together with the method of pivoting the stylus bar, and perfect insulation—effect a sensitive and free vibration—and prevent a pinched tone resulting at any time from natural contraction or expansion of the metal parts.

The reproduction is the mellow, natural quality of tone—absolutely getting away from the usual sharpness and metallic effect so noticeable in most reproducers.

Sound waves act upon the same principle as light waves—they travel in a straight line until they meet some obstruction, from which they are deflected at right angles. The right angle turn at the back of the Scotford Tonearm causes less breaking up and confusion of the sound waves than occurs in the curved arm.

The connection between the Reproducer and Tonearm is perfectly insulated with a hard rubber bushing. Inside diameter of the Tonearm is correct to accommodate the volume obtained from the latest records.

The right-side turn for changing needle is handier than the old style turn-back, and when in position for the Hill-and-Dale records there is no interference with lowering the cabinet cover.

The lateral movement at the base is simple, free and permanently satisfactory. Inside there is no obstruction to interfere with passage of the sound waves. There are no loose balls in the bearings, therefore no buzzing noise can occur from the great vibration on high notes.



Barnhart Brothers & Spindler

Monroe and Throop Streets—Chicago

"MAGNET" DECALCOMANIE NAMEPLATES



FOR TALKING MACHINE CABINETS ETC.



Pamphlets with fac-simile illustrations and prices mailed on request.



SMITH-SCHIFFLIN CO.



126 Liberty Street New York City



To Our Good Friends,
To Those who know
the "B & H" Fibre
Needles and the
"B & H" Repointers,



To all who have helped us make our
success and who know the true value of
our goods in building up Sales of Talking
Machines and Records, we heartily and
sincerely wish

A Very Merry Christmas

and

**A Most Happy and Prosperous
New Year**



"B & H"

Fibre Manufacturing Co.

33-35 W. Kinzie Street, Chicago, Ill.



LOOKED LIKE REAL BUSINESS

Why the Police Got Suspicious of "Doings" at the Aeolian Co.'s Bronx Store

Early Thanksgiving morning, 2.30 a. m., to be precise, says the Bronx Home News, "Moe" Stein, the Bronx manager of the Aeolian Co. on East 149th street, between Third and Courtlandt avenues, looking the worse for wear after a strenuous day's business, was just about to light out for home when two "cops" and a sergeant stepped into the store, and in a tone of voice that presaged trouble, said, "What's going on in here?"

"Nothin' going on in," replied "Moe." "All goin' on out. Fifty Aeolian-Vocalions and a flock of pianos. Suspicious of those hired trucks backed up there? Had to get 'em; hadn't enough of our own to go around. Folks sitting up now waiting for promised deliveries."

Sheathing their night sticks the "cops" departed, while one remarked: "It's a h— of a business that keeps a man up this hour."

There's a moral to this news story.

A PATRIOTIC SOUVENIR

The New York Talking Machine Co., Victor wholesaler, has sent to its many friends in the trade an artistic 1919 calendar, which presents a handsome portrait of General John Joseph Pershing, commander-in-chief of the American Expeditionary Forces in France. This calendar, which is entitled "To Make the World Safe for Democracy," will undoubtedly meet with a hearty welcome from the Victor dealers who are fortunate enough to receive a copy, as General Pershing's portrait is remarkably effective, being an exact reproduction from the original painting by Lotave. The New York Talking Machine Co. mailed these calendars well ahead of the Christmas rush, so that its friends could receive their copies promptly and in perfect condition.

AN EXPERT IN THE SALES FIELD

Miss M. E. Dorr Has Achieved Success as Manager of the Talking Machine Department of the Up-the-State House of W. T. Crane Co.

SYRACUSE, N. Y., December 4.—Miss M. E. Dorr, manager of the talking machine department of the W. T. Crane Co., of this city, has been achieving pleasing success in developing



Miss M. E. Dorr

business for this well-known house, which handles the Columbia and Victor lines.

Miss Dorr has had nine years' experience in the sales division of the talking machine field, having been associated with the W. T. Crane Co. for the past six years. She is considered an expert in her field of endeavor, having inaugurated many ingenious and successful sales plans in connection with the conduct of her department. She has a thorough knowledge of record catalogs, and her musical experience has been a vital factor in her success.

Nothing will starve to death much quicker than enthusiasm unless it is properly nourished.

EXCISE TAX FIXED AT 5 PER CENT.

Senate Finance Committee, In Redrafting the War Revenue Bill, Eases Up Burden Placed on Talking Machine Men By the House

It was announced late last month that the Senate Finance Committee, in carrying on its work of redrafting the War Revenue Bill, had given further consideration to the section covering excise taxes on talking machines, records and piano players, and had fixed the tax on such articles at 5 per cent. This proposed tax is just half of the 10 per cent. tax provided for in the War Revenue Bill as it left the House, and only 2 per cent. more than the excise tax at present being met by the talking machine trade under the old bill. It is believed that this reduction in tax, even though it follows some strong and effective arguments presented before the Senate Finance Committee by representatives of the talking machine industry, is really due in a large measure to the sudden change in the war situation, and the belief that the amount of income provided for in the House bill would not be necessary.

The War Revenue Bill will, of course, have a long and troublous journey before it from the time it leaves the hands of the Senate Finance Committee until it passes from the President's desk as a law, but it is firmly believed that there is little likelihood of further changes being made in the bill in the future, as far as it affects musical instruments, unless such changes are made with a view of reducing the burden placed on the trade.

TO HANDLE THE AEOLIAN-VOCALION

The Bissell-Weisert Piano Co., maintaining warerooms in the Fine Arts Building, Chicago, have just taken on the Aeolian Co.'s lines of Vocalion phonographs and Aeolian records. They also carry the Victor line and are Chicago representatives of Chickering & Sons pianos.

The Leonard Markels **BUTTERFLY MOTOR**

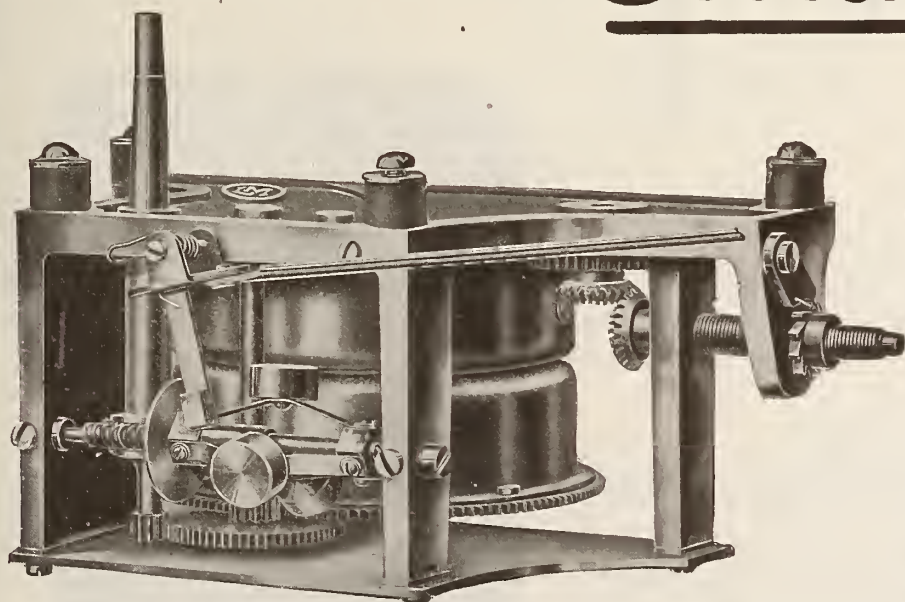

Specifications

- Beveled gear noiseless winding,
- New ratchet device that prevents clicking.
- Bakelite intermediate gear—absolutely silent.
- Plays seven 10-inch or five 12-inch records at one winding.
- Cast iron nickered frame.
- Powerful, durable, compact, accessible.
- Built especially for the highest-grade machines.
- Guaranteed in every minutest detail.

The Leonard Markels Jewel Bearing Butterfly Motor

has revolutionized the motor industry. It is silent running and silent winding and represents the acme of perfection in motor construction.

This motor has achieved phenomenal success, and is being used exclusively by leading phonograph manufacturers in all parts of this country and Canada.

Write today for a copy of our New Butterfly folder

LEONARD MARKELS - 165 William St., New York

The most wonderful Talking Machine of the present age at the price
An Instrument of Supreme Value, Tone and Quality

Cleartone
SPEAKS FOR ITSELF



No. 100—\$100



No. 75—\$75

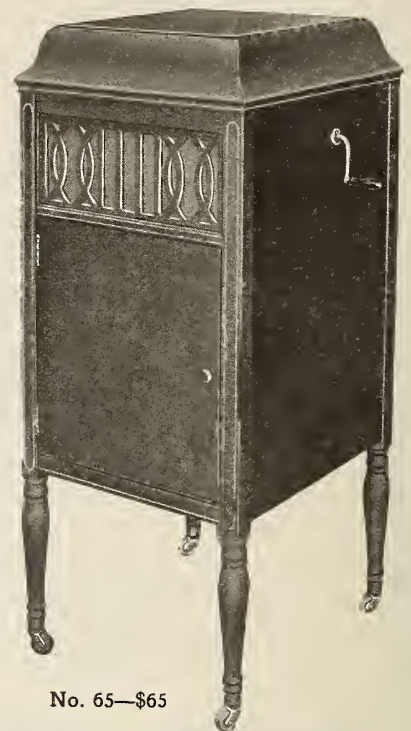

No. 65—\$65

The *Cleartone* has become very popular because of its quality, splendid value and the advertising and sales campaign that now stands in back of it. **Dealers!** Watch us grow—write for our agency and grow with us.

SUNDRY DEPARTMENT

MOTORS—No. 1, double-spring, 10-inch turntable, plays 2 10-inch records, \$3.25; No. 6, double-spring 10-inch turntable, plays 3 10-inch records, \$4.00, with 12-inch turntable, \$4.25; No. 8, double-spring, 12-inch turntable, plays 3 10-inch records, castiron frame, \$3.85; No. 9, double-spring, 12-inch turntable, plays 3 10-inch records, castiron frame, bevel gear wind, \$6.85; No. 10, double-spring, 12-inch turntable, plays 4 10-inch records, castiron frame, bevel gear wind, \$7.85; No. 11, double-spring, 12-inch turntable, plays 7 10-inch records, castiron frame, bevel gear wind, \$9.75.

STONE ARMS AND REPRODUCERS—Play all records—No. 2, \$1.45 per set; No. 4, \$3.95 per set; No. 6, \$3.75 per set; No. 7, \$3.75 per set; No. 8, \$3.75 per set; No. 9, \$3.25 per set.

MAIN SPRINGS—No. 00, 5/8 in., 9 ft., 39c. each; No. 01, 7/8 in., 7 ft., 29c. each; No. 1, 3/4 in., 10 ft., 49c. each; No. 2, 1 1/8 in., 10 ft., 49c. each; No. 3, 7/8 in., 11 ft., 59c. each; No. 4, 1 in., 10 ft., 59c. each; No. 5, 1 in., 11 ft., heavy, 75c. each; No. 6, 1 1/4 in., 11 ft., 95c. each. We also carry other size main springs to fit Victor, Columbia and all other motors at nominal prices.

RECORDS—POPULAR AND GRAMMAVOX, new 10-inch, double-disc, lateral cut, all instrumental selections 35c. each.

GOVERNOR SPRINGS—To fit VICTOR, COLUMBIA and all other motors at moderate prices. Special prices on large quantities to Motor Manufacturers.

GENUINE DIAMOND POINTS, for playing Edison records, \$1.75 each.

SAPPHIRE POINTS, for playing Edison records, 18c. each.

SAPPHIRE BALLS, for playing Pathé records, 22c. each.

NEEDLES, steel, 75c. per thousand in 10,000 lot.

We also manufacture special machine parts, such as worm gears, stampings, or any screw machine parts for motor; reproducer and part manufacturers.

Special quotations given to quantity buyers in Canada and other export points.

Write for our 84-page catalog, the only one of its kind in America, illustrating 33 different styles of talking machines and over 500 different phonographic parts, also gives description of our efficient Repair Department.



No. 85—\$85

Lucky 13 Phonograph Co., 3 and 46 East 12th St., New York

Lashanska—Stracciari—New York Philharmonic—Toscha Seidel—Josef Hofmann—just a few of the bright stars that shine in Columbia Christmas Records.

**Columbia Graphophone Co.
NEW YORK**



TELLS OF HIS WAR EXPERIENCES

Major Noyes, Former Andrews Traveler, Conveys an Idea of Strenuous Times for American Boys at the Front in Recent Letter

BUFFALO, N. Y., December 8.—Even before many Americans at home, up to a few weeks ago, were quite sure when the war would end, the Yankee boys overseas were pretty well convinced that "the big show" would soon be over. Among those who predicted the early termination of hostilities was Maj. Hal H. Noyes, who formerly was traveling representative for W. D. & C. N. Andrews, talking machine jobbers of this city. Major Noyes is attached to the motor dispatch riders, and in a letter to Mr. Andrews, he said: "Well, it looks as though this show is almost over, doesn't it? And I can't say that I'm sorry. I have just been attached to the Second Army and am leaving here shortly for the front, where I hope to be in at the finish. I just left the First Army and saw a good part of that show in the Argonne. It was tough work. The country is much like that of Northern Pennsylvania, and is awful country to fight over, especially the kind of warfare that is waged now. I'm going over it. One wonders how an advance was ever made. The Hun had 'pill boxes' machine gun nests everywhere, and there is hardly a square yard of it for miles that isn't pitted up by shell fire. In the woods, or what is left of them, the German machine gunners would stay as long as possible in hundreds of instances, until the gun crews were wiped out or captured. Then the Hun would shell the place, using plenty of gas, which will stay in the woods sometimes for days, making it extremely dangerous for our

men and always mighty uncomfortable. It is no picnic to have to wear a gas mask for hours at a time, and mustard gas is particularly nasty.



Major H. H. Noyes

If it gets on your clothes, it soon works through and spreads and makes a nasty burn. "I've seen some mighty bad cases of mustard gassing, and the funny thing is that in many instances the men don't know when they got it. Thank Heaven, I never got a dose of that, and I hope I don't. I went over a road built across what had been No Man's Land forty-eight hours before. This road was built, four miles of it, in fourteen hours, which in itself

is remarkable enough, but stop and think that most of it was done after dark. They had no grading machines—just men with shovels and picks and sand bags, practically all that time under shell fire, and they built a good, hard road, capable of sustaining heavy and continuous traffic. In fact, the stream of traffic was twenty-four hours long, and every day. Oh, it's some army we are building over here.

"Some of our youngsters in that show were green at this war game, green as grass, but they would go over the top with a yell and a laugh, and the task of the famous 'Six Hundred' was a lawn party compared to what these huskies had to do. When they learn from experience not to take so darn many chances, we won't have so many casualties, but they just won't 'keep their head down.' I came through that show in good shape, although I was air-raided and shelled a few times. They didn't get me, but several times I just knew they were after—only me. One feels that way, especially at night, when they drop those damn bombs. Lord, they do shake things up! Scared? Sure I was scared; why, I couldn't even climb under my blankets. They dropped twenty of those darn things about 150 yards from where I had been sleeping—too close. He missed his target by a mile and a half. Too careless of him! You see, he was after a dump of ammunition. Well, you feel better when they're gone, but you don't know when his cousin or brother is coming back. You don't suffer from ennui much when you're up there.

"Well, as I said before, some of us will soon be thinking of starting for home, as this show is nearly over, and I hope I'll be in the first bunch. Was one of the early birds over here."

THE WONDERFUL TONE PRODUCTION OF PHON d'AMOUR

is obtained by

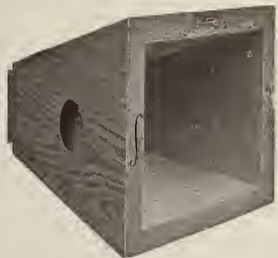

THE AMPLIFIER

an entirely new type of horn,
built on the principles of a violin

and

THE DIAPHRAGM

made of selected violin wood, fashioned beyond any possible danger of warping, and insuring a resonance and sweetness of tone, not obtainable by the use of any other material

*These Features are Patented and Procurable Only in Phon d'Amour
Plays All Makes of Records and Glorifies Them All*



**THE FRITZSCH PHONOGRAPH CO., 228-30 West Seventh Street
CINCINNATI, OHIO**

THE TRADE IN PHILADELPHIA AND LOCALITY

PHILADELPHIA, PA., December 7.—The talking machine business during November in this city resolved itself into a sale of everything that was procurable—that is, so far as the Victor dealers are concerned, and yet it did not show a volume any way near that of November of 1917. Beginning with the first of December the Victor men were all cleaned out, and with little reason to expect a much better condition during the balance of the month. There are going to be a great many disappointed people, as well as dealers and jobbers, it is apparent, for the Victor jobbers cannot see but that it will take the Victor Co. at least until spring before they will be able to ship the enormous number of machines and records that will adequately fill the demand.

There seems to be a great scarcity in other lines also, and only a few factories have been able to keep their dealers supplied in November, and to start them on the last month of the year with assurances that they are going to get plenty of goods.

Having a Wonderful Season

The Columbia Graphophone Co., 210 North Broad street, have been having a wonderful season, their November practically cleaning them up on stock. Manager Heath states that they have received a small shipment of machines this week, but they have others on the road, and he hopes that they will get enough Grafonolas to at least satisfy the dealers, although he does not hope to be able to nearly supply demands. The record condition is somewhat better, although on the most popular of the recent numbers there is a considerable shortage. E. A. Manning, of the Columbia Co., who has been seriously ill for some time, has so far improved that there is now assurance of his recovering, for which all his friends in this city are very glad.

Just Marking Time

A representative at the Louis Buehn Co. says: "The whole situation is simply this, we are going along selling all we are receiving from the Victor Co., which is not very much. From present indications it will be only a comparatively short time before the Victor Co. will be able to get back to normal, but when they do, I think they will be able to produce more than they

ever did in the history of their business. We have received a partial shipment of the new Style VI Victor, in mahogany, and it is a very fine machine for the price. The probabilities are that there will be no more of this particular type—mahogany finish—shipped again until next year."

The Buehn firm have received letters the past week from E. P. Bliss, Jr., and R. C. Carpenter, former employes at their store, to the effect that they hope shortly to be back from France and to again get "into the harness."

Among out-of-town talking machine men in Philadelphia the past week were C. N. Andrews, of Buffalo, N. Y., and L. C. Wiswell, manager

of the Victor department of Lyon & Healy, Chicago.

In Good Shape for Holiday Trade

Manager Bates, of the Victor department at the Wanamaker store, has his quarters in very fine shape for the holiday trade, but unfortunately, like all other Victor dealers, he is shy of stock, but hopes, with a little more assistance from the factory, to make the usual holiday showing. He is a little pessimistic regarding this, however, but is optimistic to the extent that he believes the Victor people will very shortly increase production so that in a few months all their dealers will have very clear sailing.

Able to Meet Trade Demands

Herbert E. Blake, of Blake & Burkart, the big Edison dealers at Eleventh and Walnut streets, says that they are plugging along and doing a very good business. Mr. Blake says: "We had a very nice month last month and it looks good for this month." We had plenty of stock and there is plenty demand for it. We had to dig for the stock, but we dug, and we are now being repaid. All the other Edison dealers in Philadelphia seem to be in the same shape. We have more machines on hand now than we had to start last month, and our business in November was more than double that of November a year ago."

Mr. Blake says that they are also in fine shape on records, and the twenty-four new records which they placed on sale on the thirtieth are of a high class and he believes they are going to be popular with the public. They have two large shipments on the way now, of machines and records, which they believe will see them through the holiday period.

The Blake firm were very much honored as well as pleased when recently a representative arrived from the Edison Co.'s factory to write up their system here to be used in the Edison official magazine, "Along Broadway."

R. N. Stults in Charge at Presser's

Robert N. Stults, for many years identified with the piano trade in this city as salesman, has accepted the position of manager of the new talking machine department at the Theodore Presser store. The Presser firm handle the Victor and the Brunswick. The department was opened some time ago and has already ob-

TALKING MACHINE DEALERS

can greatly increase their profits without additional overhead expense, by selling the world-famous

Weymann "KEYSTONE STATE" Musical Instruments

a combination that has proved to be an instantaneous success.

Write for catalogue

H. A. WEYMANN & SON

Manufacturers

Victor
Wholesalers

1108 Chestnut St.
Philadelphia, Pa.

Established 1864

A Good Time To Lay In Your Supply of Accessories

Lundstrom Cabinets—One of the best selling propositions in the Talking Machine business today.

Record Cleaner Brushes—A neat plush brush, leather back—finds a ready sale.

Record Lites—A necessity for every talking machine with a lid. Makes a fine Christmas gift.

Needle Cutters—Lyon & Healy and the Record Lite Fibre Needle Cutters. Best cutters on the market.

His Master's Voice—A Plaster Paris Miniature. Four inches high. Sells like hot cakes. Order a sample dozen.

Wall-Kane Needles—Well known to the trade. Medium, loud and extra loud grades.

Heineman Needles—in medium and loud tone.

Penn Phonograph Co., Inc.

913 ARCH STREET

PHILADELPHIA

Victor Wholesalers Exclusively

For 1919



*We pledge to our Dealers a continuance of fair and helpful Victor Service. The war's end, bringing better conditions and increased factory shipments, should mean a wonderful year of **MUTUAL PROSPERITY.***

The Louis Buehn Company, Philadelphia

Victor Wholesalers

tained a firm footing, and Mr. Stults will no doubt put much energy into the department.

Advertising Campaign Brings Results

The local Pathéphone Co. report that November was the biggest month they have ever had. This is true both in retail and in wholesale. Mr. Eckhardt believes that December will unquestionably again break all records. They recently entered into an extensive advertising campaign which has been bringing big results. This campaign was conducted not only in the newspapers, but also on billboards all about the city. The Pathé Shop name is in evidence all about the city.

Mr. Eckhardt says the Pathé Co. has been able to supply them with all the goods needed so

far in the way of machines, and record shipments have been coming in in splendid shape. E. A. Widmann, president of the Pathé Co., was a visitor in Philadelphia during the month.

Weymann Boys Meet in France

This Thanksgiving meant much to H. W. Weymann, in charge of the wholesale department of H. A. Weymann & Son, Victor distributors, Philadelphia, Pa. The mail that morning brought the pleasing announcement that his two sons, who are both serving their country in different branches of the service, had met in France. H. Power Weymann, the eldest of the two boys, went to France in Company E, 315th Infantry. In the capture of Sedan, in which the American troops played such a valiant part, young Weymann was wounded by a shell and was later transferred to a hospital in Bordeaux. Herbert Weymann, the other son, is serving as chief yeoman in the United States Navy, and is quartered at Croix d' Huis, which is within a few miles of Bordeaux. Herbert Weymann visited his brother in the hospital, and in a letter home told of the happy reunion, and the equally cheering news of his brother's rapid recovery.

New Pathé Representatives

The big furniture store, Stern & Co., in this city, have opened a Pathé department, and thus far their campaign has been most successful. They have been doing a land office business. Other firms in the State that have taken on the Pathé are: The Scranton Talking Machine Co., of Scranton, Pa.; the Cameron Piano Co., of

Cameron, Pa.; G. C. Aschbach, a large musical instrument dealer of Allentown, Pa., and the Goodenough Piano Co., of Bethlehem, Pa.

Frieda Hempel Scores in Opera

Frieda Hempel was the star of the opera last week—"L'Elisir d'Amore." This artist sings exclusively for the Edison, and consequently the Edison dealers outdid themselves here for publicity. Blake & Burkhart had an attractive Hempel window, with a big poster of Miss Hempel as "Marie" in "The Daughter of the Regiment." The first record she made for the Edison was the Proch Theme and Variations interpolated in this opera. They also had various photographs of her, and the Edison poster of all her records. Pictures and posters of Miss Hempel were also displayed by W. A. Murdock, manager of the Edison department of the Ludwig Piano Co., N. Stetson & Co., the Girard Phonograph Co., etc.

H. A. Weymann & Sons Are Optimistic

H. A. Weymann & Sons, in spite of a very heavy Victor business in November, enter the December month in better shape than the majority of Victor dealers here. They lack machines to a considerable extent in comparison with the demand, and their record shelves seem very skimp, but H. W. Weymann is optimistic as to the outcome and believes the Victor people are going to give them at least a liberal supply of both machines and records to meet the heavy demand, but of course not sufficient to nearly supply the wants of their rapidly increasing roster of customers.

THE BEST TALKING MACHINE NEEDLE
On the Market—Packed in Counter Salesman

50 Needles to a box and they retail at 10c. per Box.
60 Boxes to a package \$6.00.
This package costs you \$3.90 net.
Your profit is \$2.10 and your customer gets a needle that will give satisfaction.

The Fred. Gretsch Mfg. Co. 60 Broadway
Brooklyn, N.Y.
Manufacturers of Musical Instruments
Canadian Wholesale Agent, H. A. BEMISTER
10 Victoria St., Montreal, Can.
Western Distributor: WALTER S. GRAY
530 Chronicle Bldg. San Francisco, Cal.

AUSTRALIAN AND NEW ZEALAND TRADE

Well established firm now manufacturing and dealing wholesale in Cabinets and Disc Filing Cases is desirous of embarking further in the Talking Machine business and invites quotations and details of Motors, Voice Boxes, etc.

Buying Agents: Messrs. Henry W. Peabody & Co., New York
Address all correspondence to—
RECORDER
Messrs. Henry W. Peabody & Co., Box 932 G. P. O. Wellington, New Zealand



Dance Music for Christmas—of course. And there is no dance music like Columbia Records.

Columbia Graphophone Co.
NEW YORK

WITH PEACE SECURED PITTSBURGH LOOKS FOR BIG TRADE

Marked Activity in All Branches of Business—Kaufmann's Victrola Department—Columbia Line With Joseph Horne Co.—Buehn Co. Tell of Edison Tone Tests—Demand for Starr Phonographs

PITTSBURGH, PA., December 5.—Marked activity is noted in talking machine circles, due to the pre-holiday season publicity methods that are being utilized by the various dealers in machines and records. On all sides it is conceded that the amount of business that will be transacted in talking machines and records will only be limited by the amount of merchandise that the dealers can obtain.

This view is shared by all of the leading jobbers who are confident that had not war conditions intervened the 1918 holiday season would have been the most successful and notable in the history of the trade as far as the Pittsburgh territory dealers are concerned. This is mainly due to the outstanding fact that the varied industrial enterprises of the territory in and about Pittsburgh are working full time and the thousands of workers are able to earn excellent wages. Much of this money finds its way to the sellers of talking machines and records, as it is an established fact that the Pittsburgh district toilers have a decided partiality for talking machines as well as player-pianos.

One of the largest Victrola departments in western Pennsylvania is that conducted by Kaufmann's, one of the biggest department stores in the United States. This department is under the direction of Edward F. Harwood, who is music merchandise manager of the store, while the immediate direction of the department is in the hands of Mrs. C. H. Walrath. The department is located on the eleventh floor, and there are thirty-five demonstration booths as well as a number of display rooms where the various styles of Victrolas are on show. Another feature of Kaufmann's is the "Instant Record Service" bureau, which is located on the main floor. This has been established for the busy man or woman who wishes to get a Victor record promptly without taking the elevator to the eleventh floor. This new bureau since its inception has been very successful.

Especial attention is also given to the foreign record department, which is located in the basement, and is in charge of Arnold Haas, a linguist of note, who stated that hundreds of

foreign records were being sold weekly through his department. This is due, he said, to the fact that the foreign speaking patrons of the department are liberal buyers and seemingly do not hesitate at buying a record that they like.

The Joseph Horne Co. have placed on sale a full line of Columbia Grafonolas as well as Columbia records in addition to the Victor line, which they have handled for years. The department is in charge of A. R. Meyer, who is also secretary of the Pittsburgh Talking Machine Dealers' Association. Mr. Meyer stated that the demand for Victrolas had reached so large a volume that it was impossible to fill all orders placed in time for Christmas delivery.

A. N. Ansell, manager of the Victrola department of McCreery & Co., reported sales as very brisk and, although he found it difficult to supply his patrons with the particular style of Victrola they wished, he often was able, he said, to make a compromise and place a Victrola of either a larger or smaller size than wanted, so as to keep the customer in line for the Victor wares. Sales of records Mr. Ansell said were very large.

Assistant Manager A. B. Smith, of the local Columbia branch, stated that the trade for November both in Columbia records and Grafonolas were much larger than that of November a year ago. Thus far in December, he said, sales were brisk and orders were being placed in large volume by the retailers.

"Our sales are showing a marked increase over any similar period prior to the holidays," said H. J. Brennan, manager of the Pittsburgh Pathéphone Co., "and I am sanguine that our Christmas sales will eclipse those of last Christmas, which, by the way, was a record-breaker for this establishment.

J. A. Endres, sales manager of the Brunswick phonograph in the Pittsburgh district, is enthusiastic over the notable sales of the Brunswick in his territory. He stated that the Brunswick methods of reproduction have brought about an increased volume of sales for the retail dealers.

Mr. Brennan made a business trip to New

York the latter part of November and visited the Pathé factory.

J. W. Helbling, one of the roadmen of the Pittsburgh Pathéphone Co., was quite ill with influenza. He has recovered sufficiently to resume his route.

Miss Lillian A. Wood, director of the Victor educational department of the C. C. Mellor Co., was off duty for several weeks, due to the influenza epidemic. Miss Wood is planning a big campaign this season in the Pittsburgh schools with her educational work, which has been in operation for some time and is highly approved by educators who have seen its practical results. The Victrola department of the Mellor Co. is in charge of John Fisher, who is well known to the trade.

The Dauler-Close Furniture Co., who are the Pittsburgh agents for the Cheney phonograph, are carrying on an extensive advertising campaign in the newspapers directing the attention of the public to that line. The firm report sales as very satisfactory and in keeping with their expectations.

The Buehn Phonograph Co., Edison distributors, report a very brisk season in Edison phonographs and records. Much of this new trade is ascribed to the recent series of very successful Edison tone tests which were held in the territory covered by the Buehn Co. The retail store of the company is attractively fitted up with handsome demonstration rooms for both the Edison phonograph and the Amberola. Two new additions have been made to the staff of the retail sales force, they being Misses Z. Rohrkaste and Marie Kenney. W. S. Rippey, a member of the traveling salesmen force, has resigned.

Gray & Martin, distributors of the Sonora phonograph, are enjoying a brisk sale of this talking machine. The firm in their newspaper advertising direct attention to the fact that they accept Liberty Bonds for cash in the purchase of machines.

H. C. Niles, secretary of the Starr Phonograph Co. of Pennsylvania, stated that he was only limited in his willingness to fill orders for Starr phonographs and Gennett records by the receipt of shipments from the factory at Richmond, Ind. Frequently, he stated, when a carload of phonographs reaches Pittsburgh they are immediately reshipped to retail dealers without being taken to the local stockrooms.

The Aeolian-Vocalion is being featured by the Kaufmann & Baer Co., who are the exclusive agents for that instrument and the Vocalion records in Pittsburgh. Considerable newspaper publicity has been used the past month in directing the attention of prospective buyers to the Aeolian-Vocalion. The Kaufmann & Baer Co. have commodious showrooms for the instruments as well as for the Victrolas and Columbia Grafonolas, which they also handle.

A. Hamberger and the Goldsmith Furniture Co., who handle the Vitanola in this city, report an excellent demand for these popular instruments.

CRYSTAL EDGE MICA DIAPHRAGMS

M
I
C
A

Let us send you samples *today* of our diaphragms and you will readily understand why the best talking machines are equipped with *Crystal Edge Mica* diaphragms exclusively.

We use only the very finest selected mica, the best diaphragm material in the world.

PHONOGRAPH APPLIANCE CO., 109 West Broadway, NEW YORK



Otto Heineman Phonograph Supply Co.

INCORPORATED

25 WEST 45th STREET, NEW YORK

FACTORIES, ELYRIA, O.—NEWARK, N. J.—PUTNAM, CONN.

CHICAGO

ATLANTA

SEATTLE

CINCINNATI

TORONTO



Tone Reproduction

Buy only the highest grade HEINEMAN-MEISSELBACH Tone Arm Combinations.
Your machines will then be unexcelled in tone quality.



HEINEMAN TONE ARM No. 11
HEINEMAN IDEAL SOUND BOX No. 2

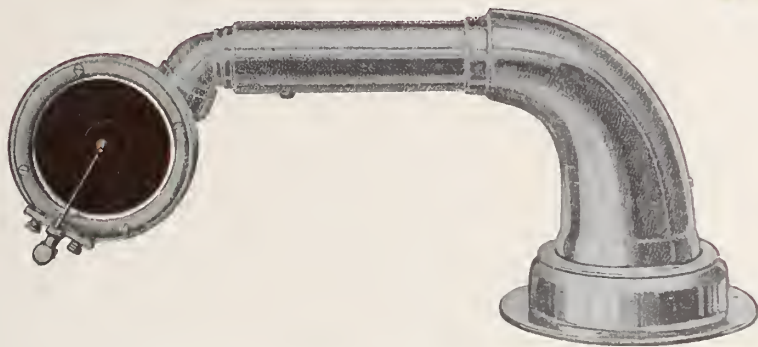

HEINEMAN TONE ARM No. 12
HEINEMAN IDEAL SOUND BOX No. 2



MEISSELBACH TONE ARM No. 97
MEISSELBACH No. 2-C SOUND BOX



MEISSELBACH TONE ARM No. 97
MEISSELBACH No. 2-C SOUND BOX



MEISSELBACH



TONE ARMS

MOTORS

SOUND BOXES

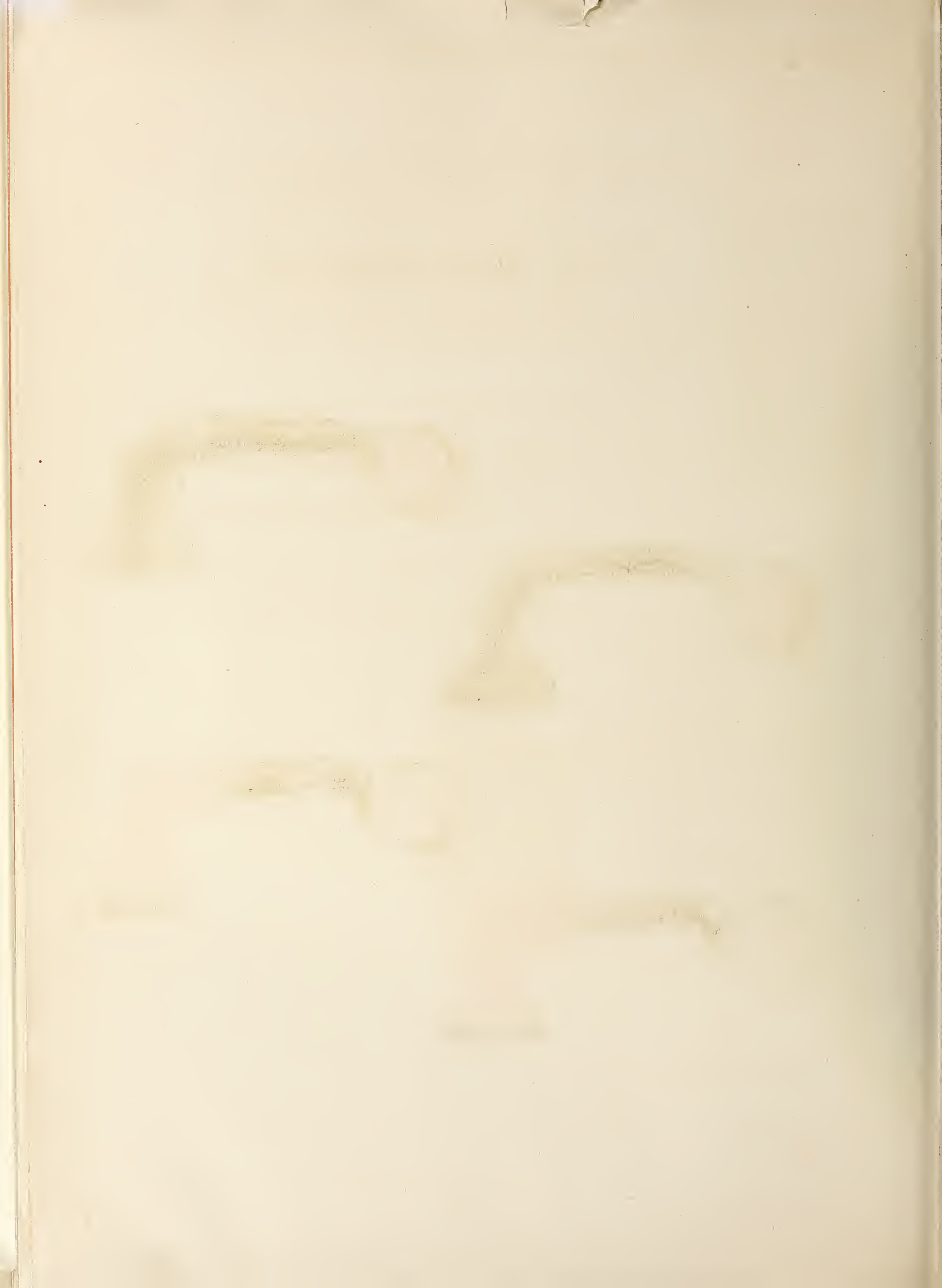

HOW RIDGLEY "DOES HIS BIT"

Well-Known Talking Machine Dealer, Organizer of 69th Regiment Band, Handles OkeH Records—Big Factor in Musical Matters

Clifford E. Ridgley, head of Ridgley's Music House, 859 Third avenue, New York, which handles "OkeH" records, is not only well known



C. E. Ridgley

For his good work, Band Leader Ridgley, who entered the regiment as a private, has been promoted to the rank of lieutenant. This rapid promotion is no

in the local trade circles, but is also conductor of the famous Sixty-ninth Regiment Band. When this popular regiment was called for overseas duty, Mr. Ridgley immediately enlisted and organized another band in the place of the one that had left for France. Under his able leadership the band soon attained a high degree of success, and it is now playing numerous engagements.

surprise, however, when it is realized that Lieutenant Ridgley has played under the batons of Sousa, Pryor and Innes, and that he is consid-

business in new and used instruments, and it is interesting to note that until the "OkeH" records were placed on the market Lieutenant



Ridgley's Sixty-ninth Regiment Band

ered an authority on band instruments and band music.

The Ridgley Music House does a very large

and he is featuring to excellent advantage the patriotic and popular numbers enumerated on these lists.

Ridgley would never consent to handle phonograph records. Referring to the "OkeH" records he says: "Speaking as a band leader, and a judge of musical instruments, I must say that the tone quality and the musical value of 'OkeH' records must please the most critical. It is a record for musical ears." Lieut. Ridgley is particularly enthusiastic regarding the recent OkeH supplements,

MANY CONSTRUCTIVE IDEAS

To Be Found in the November Issue of the "Emerson Spotlight"

The November issue of the "Emerson Spotlight," the house organ published monthly for and by Emerson record dealers, contains many timely items regarding these records, the opening article consisting of an interesting talk by Louis D. Rosenfield, manager of the Emerson international record department, who is achieving pleasing success with this new department. Mr. Rosenfield gives the dealers some idea of the problems which confront the international record department in its efforts to secure adaptable talent, and he also pays a well-deserved tribute to Harry Marker, chief recorder of the Emerson Phonograph Co., who has been an important factor in the production of these international records.

J. I. Carroll, sales manager of the company, contributes a timely article entitled "Morale," and there are the usual number of interesting items from Emerson dealers referring to the sales possibilities of these records. On the last page of this issue of the "Spotlight" there is presented a portrait of George Hamilton Green, well known in musical circles as one of the leading xylophone players of the present day. Mr. Green has recorded several Emerson records which have been well received by the dealers.

STIMULATING CHRISTMAS TRADE

In accordance with its annual custom the New York Talking Machine Co., Victor wholesaler, has been sending to its dealers different suggestions for stimulating Christmas business. Recent literature includes the usual Victor gift certificates which have achieved signal popularity in past years, and post cards that the dealers may send to their clients extending them the greetings of the season. On these cards there is reproduced a Victor record which makes this souvenir a timely one and an effective sales help for the dealers.

The Cheney Talking Machine Co., of Illinois, has registered in New York State, with P. L. James, 1107 Broadway, as representative. Capital \$100,000.

The Phonograph You Will Eventually Handle

TO improve our models at the minimum cost we have decided to concentrate our efforts of production upon the marketing of but *T-W-O* popular-priced models. This we feel is the most advisable course in face of the difficult manufacturing conditions to-day.



Model I

Height 42 inches, Width 17 inches, Depth 19 inches.

Retail Price, \$70.00

Model Number II is similar to model Number I in construction differing in dimensions only, the same being: height 46½ inches—depth 21 inches—width 19 inches.

Retail Price, \$85.00

We positively believe that the fruits of our efforts are absolutely the best that can be produced for the money. We do not offer our product to the trade as a "bargain," but as greater value for the price than any other machine on the market. We invite the most careful and deliberate inspection and comparison.

Our stock is so complete at all times as to insure prompt and immediate shipments. However, transportation is so uncertain it is advisable to order as far in advance of your needs as possible to avoid delay and disappointment.

Distributors of Lyric Records and Wall-Kane Steel Needles

Write Immediately for Unusual Liberal Discounts and Territory

ORDER YOUR SAMPLE NOW

OPEROLLO PHONOGRAPH COMPANY

54 W. Lafayette Blvd.

DETROIT, MICH.

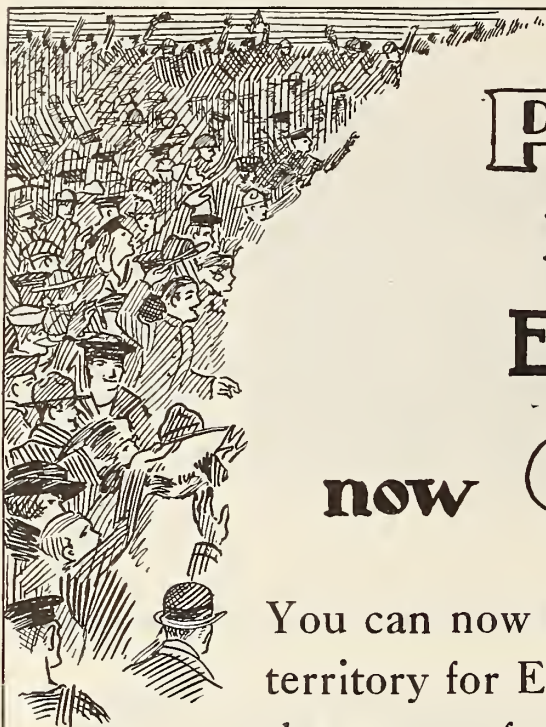

PEACE!

Demand for Emerson Records

now CAN BE FILLED



You can now fill the wonderful demand in your territory for Emerson 35 and 75 cent discs! With the return of our boys from abroad, a new era of record prosperity opens before you.

Not only can we now guarantee quantity deliveries, but you can rest assured that the superior standard of the Emerson product, due to new and splendid features, has been vastly improved.

Go after this big record opportunity with

Emerson Records

See *all* owners of machines, without exception.

Emerson Records are *first* out with the big popular song and dance hits, and first over the top with all the worthwhile numbers.

Emerson Phonograph Company INC

3 West 35th Street, New York

Chicago, 7 E. Jackson Blvd.

Boston, 80 Boylston St.



CLEVELAND TRADE IN OPTIMISTIC MOOD ABOUT FUTURE

Members of Trade Without Exception Optimistic Over Prospects for Business During Holidays and New Year—Heavy Orders for Goods Placed, But It Is Still Difficult to Get Machines

CLEVELAND, O., December 5.—With the war at an end Cleveland talking machine distributors and dealers feel like "relaxing" as it were, and all the members of the Talking Machine Dealers' Association of Northern Ohio, during their November meeting, expressed confidence in the future.

Practically all of the dealers weathered the severe conditions imposed by the war and the recent Spanish flu epidemic. With these great handicaps removed dealers see new daylight and are very optimistic over the prospects for business during the early months of 1919. Charles K. Bennett, president of the association, is among the genuinely optimistic of the group of wide-awake dealers and distributors.

Dealers hope to obtain more stock than they have received. While they admit the removal of war restrictions will not materially affect factory output for several months, these dealers see some relief in the prospect of better transportation facilities, particularly where long hauls are concerned.

Holiday decorations never were more varied and more prolific in the show windows of Cleveland music, piano and talking machine dealers. Evergreen decorations are entwined with American flags and the colors of the nations allied in defeating Germany. Patriotic music, records and music rolls, these and other evidences of "Victory" are seen everywhere.

Musically Cleveland is making bigger strides than she ever did, and in the forefront of the new movement are found talking machines, which are finding new places almost daily as drawing attractions in furniture stores, cafes and other places of business. The talking machine is no longer a mere side line with several of the big furniture houses of the city. The machine stands on its basis and is displayed prominently along with furniture.

The Harmony Music Shoppe, in The Arcade, has one of the prettiest Christmas show window displays in the city. Recent renovations and improvements in the shoppe have made its interior very inviting to the tens of thousands of people who pass through The Arcade daily.

James G. Donald, representing a Cincinnati music firm, was a visitor among Cleveland talking machine dealers this week.

The Talking Machine Dealers' Association of Northern Ohio is again planning a big concert in which singers whose songs are reproduced on records will be featured. The concert has been twice postponed and its date is now set for some time in January, depending upon the singers.

At the November meeting of the association members the concert was discussed and a committee instructed to correspond with John McCormack and others, with a view of having them appear. The date of the concert will depend largely upon the convenience of the artists sought.

The proceeds of the concert are to go to Y. M. C. A. and Knights of Columbus recreation centers in military training camps.

Association members show no disposition to lift the ban on records reproducing German songs or selections of orchestras directed by pro-German directors. These records were withdrawn from sale by the association members last summer and none have been offered for sale in Greater Cleveland since the records were interned for the war period. The probabilities are this class of records will remain under the ban until a peace treaty is signed.

Henry Dreher, of the B. Dreher's Sons Co., will spend his winter in Florida, as usual, and enjoy much of the time playing golf. He is one of the best golf players in Cleveland.

The Starr Piano Co., which recently absorbed the talking machine and record merchandise of the J. T. Wamelinck Sons Piano Co., is still making a drive in selling the instruments purchased. Many appeals are being offered for early holiday buyers.

The May Co.'s piano department, managed by Dan J. Nolan, president of the National Association of Piano Merchants, reports a big gain in business during the past few days. With the war at an end and the flu ban on early closing lifted the company's patrons have greatly increased, particularly buyers of musical instruments.

The Eclipse Musical Co.'s retail store, in Euclid avenue, is offering a wide variety of Victor machines and records. Charles K. Bennett, manager of the company's distributing department, reports an increase of sales and says the prospects for better business early next year are very flattering.

WILL STIMULATE HOLIDAY TRADE

The December issue of the "Columbia Record," the house organ published monthly by the Columbia Co. for the use of its dealers, contains a number of interesting and timely articles that can be used to excellent advantage to stimulate holiday business. One of these articles depicts the use of a Columbia Grafonola in the children's barber shop of the Wm. Filene's Sons Co., of Boston. This is probably the first time that a Grafonola has been used for this unique purpose.

In this issue of the "Columbia Record" there are the usual number of sales helps together with illustrated articles showing some of the new plans that have been inaugurated by different departments of the Columbia Co. in order to render its dealers efficient service. Among the novelties featured in this issue are the "Bubble Book," distinctive window displays and other timely sales helps.

MACOUN WITH CHAMBERS CO.

Albert Macoun, well known in the local retail trade, who was formerly associated with the Columbia Co.'s Fifth Avenue Shop, is now a member of the sales staff of the Chambers Music Co., New York, which handles the Columbia line exclusively. Mr. Macoun is closing an excellent business, and is enthusiastic regarding the future possibilities in his new post.



It Beats the Band how Phono-Grand keeps Growing—GROWING in DEMAND ! ! ! !

Look! Here It Is!



Neat, Compact; Small, isn't it?

This wonderful combination of a modern talking machine and up-to-date Reproducing Piano.

It plays all makes of Records and the piano is adapted for playing the famous Q R S expression player-piano rolls.

Don't Delay Write to-day Get More Biz The Seeburg Way!

J. P. Seeburg Piano Co.

209 S. State St. Chicago, Ill.
419 W. Erie St.

"The Music Without the Blur!"

This ideal of talking machine manufacture is attained more nearly than by any other, in the construction of the

MARVELOUS MAGNOLA "Built by Tone Specialists"

"Magnola's Tone Deflector eliminates the scratch"



Watching the Music Come Out

We want to show you how to make money with MAGNOLA; and how MAGNOLA is the best buy on the Talking Machine Market to-day.

Send us your name and let us send you some real Talker Tips.

MAGNOLA TALKING MACHINE COMPANY
 OTTO SCHULZ, President
 General Offices Southern Wholesale Branch
 711 MILWAUKEE AVENUE 1530 CANDLER BLDG.
 CHICAGO ATLANTA, GA.



Victory

Peace

The Indomitable Courage of the American People
Prebailed in Crushing the Hellish Hun

Victory and Peace have been won by Sacrifice
Sacrifice of Life, Money and Personal Interest

UNICO SERVICE

was dedicated to

The Cause of Victory

for the period of the War

Day and Night our entire facilities were devoted to
the requirements of the Aeroplane and Hydroplane
Program of Army and Navy

With the World at Peace we again turn to the Pursuit of Pros-
perity and Happiness

The Eyes of the World are turned towards this Nation

First: In Ferbor of Gratitude for Deliverance

Secondly: In appeal for every commodity required for the re-
construction of devastated Europe

Every phase of our own internal Commercial and Industrial
Activity, temporarily arrested by the Call to Arms, will be resumed
with greatly increased vigor.

This country may well anticipate unprecedented prosperity for
years to come.

THE UNIT CONSTRUCTION COMPANY

RAYBURN CLARK SMITH, President

Fifty-eighth Street and Grays Avenue, PHILADELPHIA, U. S. A.

Unico



Designs and Construction
Patented

System

THE SALES BUILDER

Unico Equipment
Excels from Every
Standpoint

- Design** Six standard styles
Special period styles
- Construction** Patented, Interlocking
Portable Units
Sound Insulated
- Finish** All standard Oak,
Mahogany and Enamels
- Efficiency** Increased sales at lower
cost per sale
- Economy** Moderate first cost
Always an Asset
Adaptable any location
- Delivery** Prompt shipments from
stock ready for immediate use



Prepare

Stupendous 1919 demand for
Talking Machines and Records

Victory

Huge sales and profits will reward
the wise Dealer who installs a
modern Unico department

Peace

will make ample stocks available

**ENLARGE YOUR
DEPARTMENT NOW**

Install a Complete Unico Department

- U** DEMONSTRATING ROOMS
- R** RECORD RACKS
- J** RECORD COUNTERS
- C** DISPLAY ROOMS
- D** DECORATIONS-FURNISHINGS

The Unico System has
Increased Sales and Profits
for almost 1000 dealers



Send to-day dimensions of your available space. Plans and estimates for a complete department will reach you promptly. By acting now you can complete your improvements in season to be ready for **THE BIG BUSINESS.**

THE UNIT CONSTRUCTION COMPANY

RAYBURN CLARK SMITH, President

Fifty-eighth Street and Grays Avenue, PHILADELPHIA, U. S. A.

COLUMBIA DEALERS HOLD IMPORTANT MEETING

Recent Monthly Gathering at Waldorf-Astoria Proves Interesting—Miss Maurel Makes Debut—R. W. Knox Outlines Advertising Plans

During the past few months Columbia dealers in Metropolitan territory have attended regular monthly meetings for the purpose of hearing the new midmonth records, and in order to become acquainted with many of the new additions to the Columbia recording library. These gatherings have been remarkably successful, but the meeting held recently at the Waldorf-Astoria Hotel was by far the most successful and most important that has yet been held.

As usual, Lambert Friedl, manager of the



Miss Barbara Maurel

local Columbia wholesale branch, sponsored this meeting, and arranged the many details incidental to the successful program that was offered to the dealers. It was suggested that the dealers bring the members of their sales staffs if possible, and quite a number of the local Columbia representatives accepted this suggestion

and gave their sales people an opportunity of attending this meeting.

In his address of welcome Mr. Friedl called attention to the splendid outlook for business during 1919, commenting upon the fact that the Government has recently permitted talking machine manufacturers to double their production, and also called attention to the announcement sent out by the Columbia Co. to the dealers canceling the price increase which went into effect November 1. In addition to this cancellation, the dealers were notified that all the Grafonolas which they had purchased since the first of the month on the new basis would be subject to the old prices, and a credit charge be entered on the books.

Mr. Friedl played the various midmonth records. Ralph W. Knox, advertising manager of the Columbia Graphophone Co., who has been responsible in a considerable measure for the splendid Columbia publicity that has appeared recently, gave the dealers an intensely practical and informative resumé of Columbia advertising plans and policies. Mr. Knox pointed out how the dealer could tie up his local establishment to this mammoth advertising campaign, and visualized this campaign by the use of charts and drawings. Mr. Knox's address enabled the dealers to gain an intimate idea of the aims and ideals of the Columbia Co.'s advertising plans, and Mr. Knox pointed out that the foundation of this campaign is a desire on the part of the company to assist and co-operate with Columbia dealers in every possible way.

As the "star" event of the afternoon Mr. Friedl introduced to the dealers Miss Barbara Maurel, the gifted mezzo-soprano, who has recently joined the Columbia recording library and who will make Columbia records exclusively. It has been said of Miss Maurel that she has a "perfect voice for recording purposes" and

NO STAINS IN OUR
MICA DIAPHRAGMS OF BEAUTY
THE INTERNATIONAL MICA COMPANY
Factory, 37th and Brandywine Streets Office and Sales Department, 1228 Filbert Street
PHILADELPHIA

musical experts who have heard her Columbia records unanimously endorse this opinion.

At this meeting Miss Maurel rendered a number of selections which were enthusiastically received by the dealers. She was obliged to give several encores, and every one present commented upon the beauty and culture of her voice and her rare gift of perfect interpretation. Miss Maurel has specialized to a considerable extent in the singing of old-time ballads, and her



Ralph W. Knox

Columbia records are excellent reproductions of her splendid voice.

Miss Maurel's accompanist at the meeting was Sig. Romano Romani, who directs all the Italian work at the Columbia recording libraries. Sig. Romani is an artist of exceptional ability, having composed a number of selections that have attained considerable success.

During the course of the meeting an interesting announcement was made to the effect that Nora Bayes, the popular comedienne and exclusive Columbia artist, will in the near future make ten-inch Columbia records, retailing at 85 cents. These records will be issued very shortly.

The next speaker on the program was F. W. Gibson, who was the father and originator of the idea which resulted in the production of the new book, "The Lure of Music," which is being presented by Columbia dealers throughout the country and which is meeting with a ready sale. Mr. Gibson gave the dealers an interesting resumé of his experiences in the preliminary work incidental to the production of this book, and then introduced Olin Downes, musical critic of the Boston Post, who wrote "The Lure of Music." Mr. Downes favored the dealers with a valuable talk on music from a practical viewpoint, and at the close of his address the dealers present versed the opinion that "The Lure of Music" cannot only be offered to their patrons from a literary and musical standpoint, but that it can be utilized by the dealers to develop sales.

Following Mr. Downes' address Mr. Friedl announced that an open forum would be inaugurated at this meeting at which the dealers could discuss at length any ideas and thoughts which occurred to them as important in the conduct of Columbia business. Irwin Kurtz, well-known Columbia dealer, presided as chairman at this meeting, and the many suggestions and ideas which were offered during the course of the open forum served to demonstrate conclusively that this feature should be included regularly in every meeting hereafter.

Mr. Phonograph Manufacturer:

How are you planning to hold the largely increased Phonograph business you have secured due to war conditions?

Soon real competition will start again.

Have your Phonographs been boosting or knocking your future?

Your claims for tone superiority will now have to be proven.

THE "BLISS" REPRODUCER, with its treated silk diaphragm, can positively prove its tone superiority.

As tone specialists, may we not aid you more effectively in meeting the coming competition?

Every standard make of Phonograph can be improved if fitted with a "BLISS" Reproducer.

Other Phonograph Specialties that we are featuring are the "Disk-Lite," an electric lighting attachment adaptable to any phonograph, and the "Phono-Lite," an automatic lighting attachment for the New Edison; also Diamond and Sapphire Points, Pathe Sapphire Points, Lakeside Rotometers, Johnson Electric Motors, B & H Fibre Needles, B & H Fibre Needle Repointers, and the Vallorbes Semi-Permanent Needles.

Write for our dealers' price list,—or
may our Parcel Post Salesman call?

WILSON-LAIRD PHONOGRAPH CO., Inc.
29 West 34th Street NEW YORK CITY

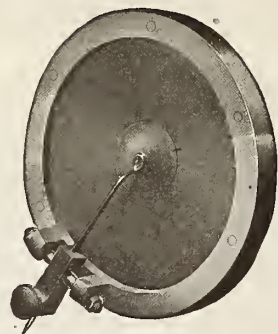

Prospects in the Talking Machine Industry During the Period of Readjustment Discussed

The reconstruction or readjustment period following the war, and upon which we may be said to have now entered, presents many problems for the earnest consideration of the manufacturer and the merchant in every line of business. The reconstruction period will bring with it a new situation that must be met in new ways and without precedent to act as a guide, just as the war itself forced a general revolution in industrial methods. Members of the talking machine industry had the satisfaction of feeling that any industry that has weathered the trials of war as successfully as has this of ours should have little difficulty in getting back on a peace basis as rapidly as conditions will permit and then enter into what is expected to be a remarkable period of development to make up for the time lost.

The thinking members of the industry, however, realize that relief cannot be expected instanter, but must come gradually because the turning over of the industries of the nation from a war to a peace basis cannot be accomplished over night. Restrictions on materials and output have been lifted by the Government, but there still exists the natural question of supply and demand which will mean that all industries will be in a rush to get materials and must be content for a while to accept a fair share of the available supplies rather than expect to have all their requirements met without delay. Then there comes that very important question of labor, and this is the big problem that will probably delay quantity production for some little time, or until mechanics can be brought back from war work.

The coming reconstruction period finds the talking machine entrenched more strongly than ever in the hearts of the American people, who, during the war, have had manifold opportunities for learning the real importance to the nation at large, of the music as furnished by talking machines and records of all the various types, forms and names.

We enter into the period, therefore, with a buyers' market awaiting us, for there are thousands of talking machine owners and would-be talking machine owners who have been unable to have their demands met owing to shortage of output. These demands are still active and insistent, and simply to take care of the business that is waiting apart from the business that will be developed, is a problem.

That the prominent men of the industry are as one in holding optimistic views regarding developments in the immediate future is evidenced in the following expressions of opinion:

COUNTRY IS ALREADY LAUNCHED INTO THE TRANSITION OR RECONSTRUCTION PERIOD

By Henry C. Brown, Sales Manager, Victor Talking Machine Co.

While any predictions regarding the immediate future, so soon after cessation of hostilities and before the organization and assembling of the peace convention, might in all reasonableness be generally accepted as premature—yet the almost instantaneous action of the Government in modifying conservation orders, canceling and readjusting war orders, makes it plainly evident that we are already launched into the transition or reconstruction period.

I have absolute confidence in the American people and their ability to meet new conditions. Particularly is this confirmed when we review what has just been accomplished after only nineteen months' preparation. When the United States became an active belligerent and joined the Allied cause our country faced conditions far more threatening and vastly more serious than now. That such a responsibility was entered into so willingly and heartily and I might say on the part of many so blindly, without regard to future consequences, convinces me that the transition or reconstruction process will be even more safely and expeditiously carried out.

Preparation for war and its vigorous prosecution naturally signified violent disturbances to all established economic processes. It necessitated the almost immediate scrapping of all the fundamental ideas of personal or individual prerogatives; it required almost revolutionary reorganization of the manufacturing facilities of the country along entirely new and untried lines; it compelled a dislocation in the labor market beyond the reckoning of the wildest theorist; it commandeered raw materials almost to the limit of our country's resources and it taxed business and the individual far beyond what anyone thought possible to absorb. These things were only a few of the serious problems met and overcome in the move from peace to a war footing.

Now, the entire process is reversed—everything is being given back, returned. Victory has been won and the menace of the Hun no longer threatens. All uncertainty is over.

Anyone who will seriously review our experiences of the past four and one-half years, and particularly the last eighteen months, must be convinced that our problems of the future are simple in comparison. We must not lose sight of the fact that all our efforts will have a definite objective, and each individual manufacturer or

merchant is or should be prepared to handle his own particular problems with prompt decision and in thorough accord with the new ideas born of the Great War.

The talking machine industry should and prob-



Henry C. Brown

ably will be among the first to return to and even surpass pre-war factory production, and with normal or increased output will find a market that has been greatly expanded by its widely recognized service to all branches of the army and navy, Red Cross, Y. M. C. A., and other governmental agencies, in providing recreation and entertainment to the boys at the front, on board ships, in the cantonments, hospitals, trenches, dug-outs, huts and in the mil-

WHAT THE WAR HAS ACTUALLY ACCOMPLISHED FOR THE BENEFIT OF THE PHONOGRAPH INDUSTRY

By William Maxwell, Vice-President and General Manager, Thos. A. Edison, Inc.

I am very glad indeed to tell what I think the war has done for the phonograph industry. I was too old to go "over there" as a soldier and too poor to go in any other capacity. Accordingly, I can speak only from hearsay of the part that music has played in the war on the other side of the ocean. I need not repeat what General Pershing and others have said about music and in particular about the phonograph. It is sufficient to say that music—and perhaps the phonograph most of all—has come to be recognized as "a munition of war."

lions of homes throughout the United States.

Up to early in the Spring of 1918 the Victor trade showed a constant and substantial increase over each preceding year, but when at the request of the Government we undertook the manufacture of aeroplanes, gun-stocks, gas shells and other intricate mechanical parts for the ordnance and navy departments, our output of Victrolas and records began to fall off and the trade consequently and very naturally were obliged to suffer many disappointments and some losses, in attempting to meet the demand for our product. These losses, however, it should be understood, were even more serious to ourselves, as the war work undertaken by us was in no sense a profitable substitute for our regular line. Our losses have aggregated millions and the compulsory relaxation in our sales promotion plans must be overcome by renewed and redoubled effort for some time to come.

During the summer just passed knowledge of insidious rumors, greatly exaggerating our curtailment and the reasons therefor, first began to reach us, and it was not until September 13 that we felt privileged to advise the trade in our war statement No. 1 of the situation at the factory and the conditions responsible for our reduction in output. This was supplemented by war statement No. 2 on October 30, which only preceded the signing of the armistice by twelve days. Now it is all over and everyone may look forward to the prosperous days that are bound to come with confident assurance that there will be returned to them full recompense for all the sacrifices they have made—which were slight indeed compared to the sacrifices of those men who fell in France and to the crippled ones who return to our shores after having done their utmost to make the world a decent place in which to live.

While I could not go on the witness stand and testify what music and the phonograph have done in France, I know something of what they have accomplished in this country. The war has put music into the souls of the American people. Thousands of unpublished poems have been written in our hearts and millions of untrained voices have joined in noble choruses of patriotism. Always intense feeling seeks to translate itself into music. Those who have the gift compose music; those who can sing instinctively

(Continued on page 50)

PROSPECTS IN TALKING MACHINE INDUSTRY DURING PERIOD OF READJUSTMENT—(Continued from page 49)

burst into song; those who cannot make music love to listen to it in times of stress. The phonograph has been the great music maker. No household is so humble that the phonograph cannot bring to it the best there is in music. During the war the phonograph, while comfort-



William Maxwell

ing the heartsick and strengthening the resolution of the irresolute, has also elevated the musical culture of the American people. The war has made the public recognize the phonograph as a practical essential to modern existence.

In the past there has been a class of people which did not regard the phonograph seriously. This class was aptly characterized by Mr. Edison in a letter which he wrote to a United States Senator, from which I quote as follows:

"It occurs to me that men like yourself and

your colleagues, with your time fully occupied and welcoming a moment of leisure instead of wondering what to do with your spare time, can scarcely appreciate what the modern phonograph means in the average American home. Comparatively few people have the mental initiative to employ their leisure hours in purposeful study. The bulk of knowledge and practically all culture are derived by a gradual process of more or less unconscious absorption. The phonograph in its modern state of perfection has, in my opinion, during the past five years done more to develop an intelligent appreciation of music on the part of the American people than all other agencies combined."

I am very happy to say that the class of people which Mr. Edison describes has been largely converted as a result of the war. The phonograph industry enters upon peace with the phonograph recognized not only as a musical instrument of equal dignity with the piano and violin, but as the greatest of all musical instruments, because it imposes no limitation of skill in operation. It is the only instrument that is always ready to give every member of the family exactly the kind of music he desires and exactly as much as he desires.

I understand the cigarette people are thanking the war for putting the O. K. on cigarettes

and that they expect to reap a great peace-time harvest. Certainly if the war established the cigarette in public esteem it has done ten times as much for the phonograph. I hope every phonograph dealer in this country will bring himself and his sales force to the realization that everybody now wants a phonograph. That conviction means millions of dollars in additional sales and it means additional comfort and happiness in thousands of homes. People want phonographs. Phonograph dealers should make it hard for anyone to avoid buying. Salesmanship is partly the art of making people want to buy and partly the art of making it difficult for them not to buy. The public is already half sold. To do the rest will be easy if we strike while the iron is hot.

As for production, that prosaic thing which after all is going to determine the amount of sales during the next twelve months, I can of course speak only for ourselves. We are literally turning ourselves inside out to regain the manufacturing momentum we lost because of the governmental curtailment order. Of course it is too late to accomplish much before Christmas. However, we hope to have an adequate supply of our entire line of phonographs shortly after the first of the year and we feel certain that we shall have a copious supply of records.

THE DEMANDS OF THE FUTURE AND THE OPPORTUNITIES FOR 1919 ARE ABSOLUTELY UNLIMITED

By H. L. Willson, Vice-President and General Manager, Columbia Graphophone Co.

America's part in the world war and its successful outcome is a matter of pride to every American. Likewise the phonograph's contribution to this success is justly a matter of pride to every individual associated with our industry. We have the right, as an industry, to a feeling of complete satisfaction that we have given immeasurable and incalculable aid to our Government, and pleasure and comfort to our soldiers

and sailors. The splendid part played by the phonograph in the world's crisis has proved it an essential thread in the fabric of our nation's well being, and therein are we proud to be associated with the phonograph industry.

Little need be said of the demand for phonographs and records during 1918. That has been obvious to manufacturers, dealers and users.

(Continued on page 51)

A Post War-Time Problem—**Its Solution**

The overhead expense of the average dealer has risen greatly during the past two years and in addition to this a scarcity of machines has somewhat curtailed his sales volume. A reluctance has sometimes been shown to taking on a competing line.

The Eject-O-File Solves It

It sells easily. Its many advantages are instantly apparent to your customers. As easy to sell with a machine as the records. Each sale means an extra profit with no additional expense.

Eject-O-Files Are Built to Fit: Columbia Style 75. Vocalion Styles F, G, H, I, J, K, and Edison Styles C150 and 100.

Retails at \$10. In beautiful oak or mahogany finish. Polished, wax or dull finish.

Write for descriptive circular and details so that you may see the opportunities this line holds for you.

EJECT-O-FILE SALES CO.

216 W. SARATOGA STREET ❖ ❖ BALTIMORE, MD.

THE FIRST ANNIVERSARY

of the Introduction of Vallorbes Semi-Permanent Needles,
with Recent Perfections Obtained, Suggests a New
Era of Ever Increasing Demand for this
Eminently Superior Type of Needle,

especially because of its one piece construction, more sturdy Needle Points and the recently developed and perfected operation of correctly chamfering corners of Extreme Needle Points, thus eliminating the necessity of first few grooves of Records to accomplish this, with its somewhat destructive influence to that portion of Record.

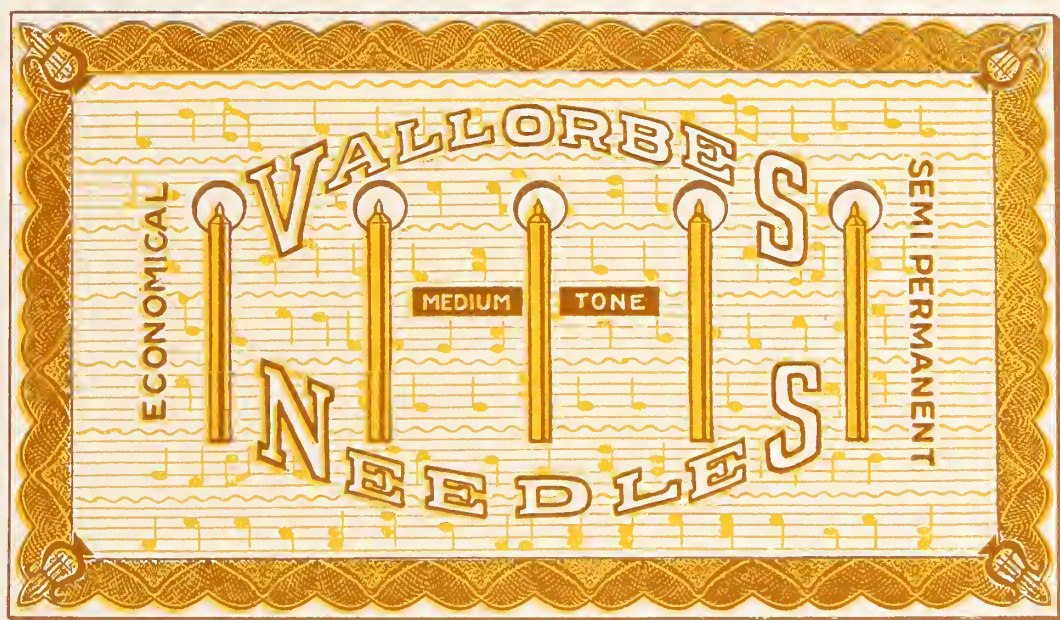

If you have a sincere desire to serve the interests of your customers in a constructive way—which,—in this case amounts to supplying needles that are not destructive, are one hundred per cent perfect in reproducing qualifications, are a real convenience and economy, decide for yourself, test and prove it for all times, obtain a Microscope and some other Types of Needles, especially the two piece point insert type of Semi-Permanent Needle, then compare them microscopically with one piece type of Semi-Permanent Needles, then play them and we will be well content with your decision, following such tests.

Vallorbes Semi-Permanent Needles for Playing Lateral Cut or Steel Needle Type Records at Present Supplied in Soft-Medium and Loud Tone, with the Possible Addition of Extra-Loud Tone Being Added Ere Long.

DEALERS should not omit to write us at once for Samples ; if you are a legitimate Phonograph Dealer and will write under Letter Heading confirming this fact you will receive Samples free.



LANCASTER, PA.

JOBBERs in territory not already well represented will do well to communicate with us and make early association with a line of ever-growing permanence that will celebrate many Anniversaries, each more glorious than the one just passed.



PROSPECTS IN TALKING MACHINE INDUSTRY DURING PERIOD OF READJUSTMENT—(Continued from page 50)



H. L. Willson

The demand for the future—the opportunities for the industry in 1919—are unlimited. We

are on the threshold of the greatest days in our industry. From a manufacturing standpoint, labor will be more stable, material more plentiful, and a larger and better output a natural consequence.

With the termination of the world war, a feeling of optimism has spread over the entire country, and while the reconstruction period must not be one of extravagance, thousands of people who have been practising the strictest economy and devoting their money and time to war work will now seek relaxation, entertainment and amusement. It is in this direction that the phonograph has had such a splendid opportunity to prove its worth. To the fighting men "over there" and to those left at home, it has filled a great national need and has been the source of comfort and cheer. It has proved its merit in camps and at home and has made a place for itself in the hearts of thousands who never before realized its value. All this spells demand to me.

So, with the assurance of improved manufacture and service, enlarged uses and multiplied users, it is the conviction of the writer that, notwithstanding the perplexities attending the readjustment period, the phonograph industry will find in 1919 a year of great business opportunity, growth and prosperity.

flected in the steady growth of our export business in the future.

While it is true that the phonograph industry has been obliged to face unprecedented conditions in the past year, the industry as a whole has undoubtedly gained in prestige as a result of its hearty support of every movement that aimed to better the Government's interests and to help win the war. Last year I offered as a trade slogan the phrase "A Phonograph in Every Home," and this prediction would certainly have materialized, if it had not been for the unusual conditions that confronted us in 1918. However, I firmly believe that 1919 will be the greatest phonograph year in history, and the slogan "A Phonograph in Every Home" can again be offered to the trade with the assurance that it will be fulfilled during the next twelve months.

WAR PROVES PHONOGRAPH A NECESSITY IN WAR TIME

By George E. Brightson, President, Sonora Phonograph Sales Co., New York

The services of the phonograph in the war have been varied. For instance, over 25,000 portable style phonographs were shipped by us via England for the boys in the trenches. From New York we have sent instruments to the big

WHY THE TALKING MACHINE INDUSTRY CAN LOOK FORWARD TO AN ERA OF PROSPERITY

By Otto Heineman, President, Otto Heineman Phonograph Supply Co., New York

Fundamentally I have always been an optimist, for I have consistently maintained that the optimist creates trade, while the pessimist discourages it. In other words, the optimist is constructive, while the pessimist is destructive. During the past year and a half I have endeavored to spread the doctrine of optimism throughout our trade, and even when our problems became most serious I felt that the outlook was not so dark as many members of our industry honestly believed. I will admit that I am considerably pleased with the optimistic spirit the trade has evidenced, for it seems to me as though the talking machine industry has "weathered the storm" and can now look forward to an unprecedented and extended era of prosperity.

To my way of thinking, the outcome of the war has placed America in a position where she has tremendous possibilities to develop every trade channel. America is to-day the greatest

financial power in the world, and, in addition, has strengthened in all directions her supremacy and prestige as the greatest industrial country in the world. I believe that there will be wonderful opportunities for America's industries during 1919, and the years thereafter. These opportunities will not only exist in the expansion of domestic trade within this country's limits, but the possibilities in the export field are almost beyond conception and will continue to develop enormously.

Judging from the opinions expressed by the industrial leaders of this country, America is going to take advantage of her export opportunities during the coming year and a careful study of the export situation will convince every American business man that this country, in a comparatively short while, will control the vast export trade formerly controlled by European countries.

For many years I have been in close touch with the developments in the export field, and I have noted with pleasure the practical assistance and co-operation extended by the various American associations that have been formed for the purpose of stimulating the interests of America's industries in their export activities. These associations have rendered invaluable co-operation to all industries, including our own, and this co-operation will undoubtedly be re-



George E. Brightson

boats plying across the Atlantic, to hospitals, cantonments, camps, etc., etc.

A Leslie's Weekly photographer several months ago snapped a picture of some of the gallant lads at the front enjoying their wine and bread in front of a dugout on the Western front. (Continued on page 53)

DOEHLER DIE-CASTINGS

Have been an important factor in the development of the most successful talking machine attachments on the market.

This, together with the fact that the greatest number of instruments produced are equipped with tone arm and sound box of Doehler manufacture, is a tribute to the uniformly high quality of our product and the all around dependability of our service.



The Success attained by the "Perfection" reproducer and tone arm is due to the popular recognition of a device of more than usual merit.

DOEHLER DIE-CASTING CO.
 MAIN OFFICE AND EASTERN PLANT
 BROOKLYN, N. Y. NEW JERSEY PLANT
 WESTERN PLANT
 TOLEDO, OHIO. NEWARK, N. J.

Plan and Prepare Now for 1919

The PRESTIGE of SUCCESSFUL MERCHANDISE JOBBING for over 50 CONTINUOUS YEARS Should COMMEND our PHONOGRAPH PROPOSITION TO YOU as a "SAFE ONE TO TIE TO"

TEL-O-TONE

• (Reg. U. S. Pat. Off.)

"The Soul of Music Dwells Within"

PERSISTENT DEMANDS on the major part of a *great Music-loving People*, calling for a more faithful, lifelike and satisfying reproduction of original Tones and Sounds than has heretofore been possible from any of the existing Sound Reproducing Mediums, has been the incentive for the Attainment of a Cherished Ideal.

It is a pleasure to proclaim this as an Accomplished Fact, and submit with pride, the Tone Sensation of the Century.

THE ONLY
PHONOGRAPH IN THE
WORLD IN WHICH
THE TONE IMPROVES
WITH USE AND AGE

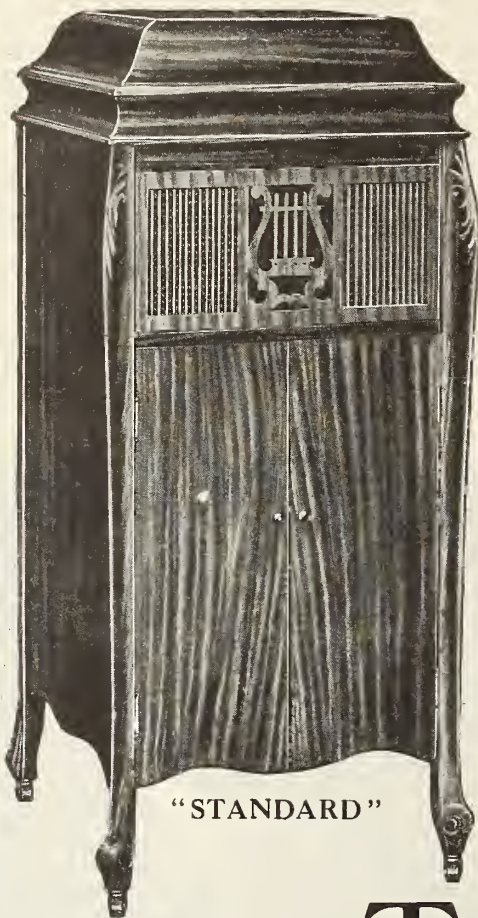

"STANDARD"

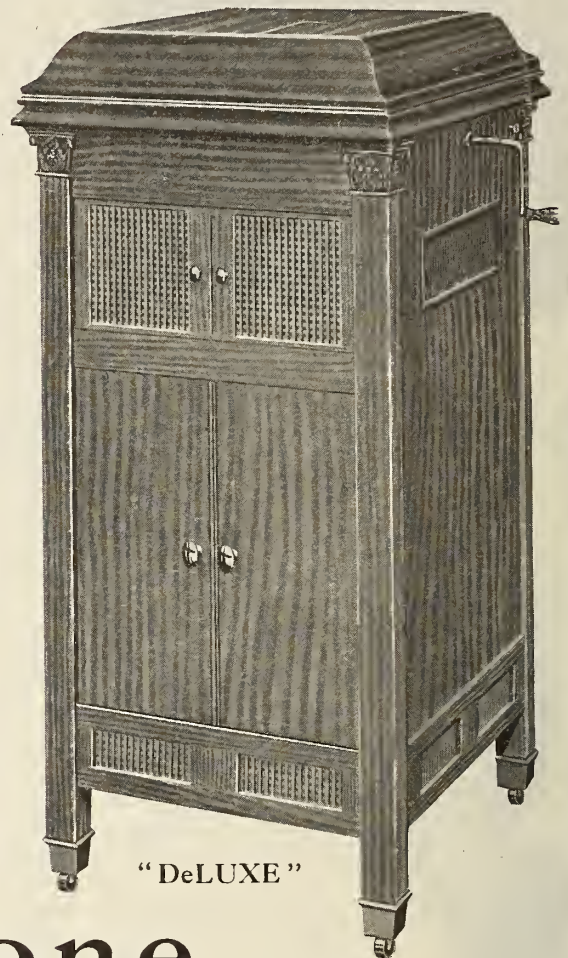

"DeLUXE"

Home of the Tel-o-Tone

WHOLESALE
DISTRIBUTORS
are invited to
GET IN TOUCH
with US for
ANTICIPATED
OUTPUT
for
1919
OUR
PROPOSITION
is
VERY
ATTRACTIVE
May we send it to
YOU?



RETAIL DEALERS
find OUR Line
a REAL
"Musical Find" with
ENORMOUS
SELLING
POSSIBILITIES
May WE assist
YOUR NEEDS
for
THE COMING
YEAR?

CATALOG with FULL
PARTICULARS for LIVE
WIRE DEALERS ONLY
WRITE TODAY

THE WESTERN NEWS COMPANY
21-29 EAST AUSTIN AVENUE, CHICAGO

PROSPECTS IN TALKING MACHINE INDUSTRY DURING PERIOD OF READJUSTMENT—(Continued from page 51)

Though the surroundings were only desolate ruins a little phonograph perched atop a box apparently was keeping everyone cheerful.

Before the war started we hardly knew the meaning of the word morale, but to-day it is understood and its importance is appreciated.

Whether it is to cheer a homesick doughboy attacked by the "blues," to lighten the pain of the wounded, to assist in restoring to normal health the shell shocked, to bring new vigor to weary bodies and new hope to the downcast in spirit, the phonograph, convenient, capable of being played by anybody and needing no expert's hand, has been of priceless value in helping the workers at home and the fighters "over there" during the great struggle for right and

justice which we have victoriously concluded.

Some people have been surprised that the demand for phonographs continued without cessation throughout the war. They have been under the impression that the phonograph is a luxury and all luxuries must be left severely alone during economical periods.

However the phonograph now is not in the luxury class, but is to-day a necessity for the home.

The perfection of the musical qualities of the talking machine has been steady and noteworthy, and the phonograph to-day is recognized as the peer of its older brothers, the piano and violin especially, as a means of enjoyment and entertainment.

TRADE STARTS NEW YEAR WITH RENEWED COURAGE

By E. A. Widmann, President, Pathé Frères Phonograph Co., Brooklyn, N. Y.

In looking back over the last twelve months and reviewing all the difficulties and hazards experienced, it is with a sigh of relief that the merchant looks to the future knowing that it must be better than has been the past. So he will start the new year with renewed courage and renewed determination to overcome any obstacle that he might encounter.

There is no question at the present time that orders are much more abundant than are supplies—that this is a seller's market and will be a seller's for a long long time to come. Supplies

that go into manufacture are still enormously high while the finished product has not advanced commensurate with the advance of raw material, labor and overhead—the dealer's profits remain practically the same except of course it costs him proportionately more to do business, but if he will buy what goods he can get no doubt he will be able to sell and sell more than he ever sold before.

There is bound to be a shortage in labor for a number of years to come. The migration of labor to this country has practically ceased during the war, and it is going to take some years for us to catch up and make up the deficiency that exists now irrespective of the fact that our own boys will be coming back. So that I look for a high labor market and consequently prosperous conditions for the phonograph industry for some time to come.

LEADING JOBBERS OF THE COUNTRY TELL OF LOCAL CONDITIONS AND PROSPECTS

An Interesting Symposium, Giving the Views of Many of the Leading Talking Machine Jobbers, That Will Be Read and Studied With Profit by Readers of The World

HARGER & BLISH, Des Moines, Ia.

Iowa and South Dakota, in which we are interested, are, as you know, the great food-producing States of the Union, and with a Government guarantee to the farmer on the price of the 1919 crops it seems to us that business prospects for next year are such that our sales volume will be limited only by the manufacturers' ability to supply us with sufficient instruments. We are pleased at the inclination on the part of the public to relax and get into a pre-war normal state of mind and an attitude of again indulging their tastes and desires for luxuries and the good things of life, and we are sure that 1919 presents unlimited possibilities to our particular trade.

W. E. KIPP, Kipp Phonograph Co., Indianapolis, Ind.

As president of the Edison Disc Jobbers' Association, I am happy to inform you that all of the Edison Disc Jobbers seem to be unanimous that their business is as good as the factory can make it. By this I, of course, mean that the business is controlled entirely by the amount of goods that we jobbers can get.

I feel sure in saying to you that all of the Edison jobbers look to the future with a spirit of optimism and that they fully intend to take every advantage of their opportunities and in every way apply themselves to the suggestions set out in Mr. Edison's recent letter. As far as our zone of operations is concerned, we feel confident that our business will continue to show a steady growth and also I am sure that our dealers will prove themselves worthy of the opportunity that is ahead of them.

BECKWITH-O'NEILL CO., Minneapolis

The Northwest, being fundamentally a producer of food and raw material rather than an industrial center, will be but little affected by any economic and labor adjustments in the immediate future. The copper, iron ore, lumber and farm products of this section, upon which our prosperity so largely depends, run no risk

sells goods rather than terms, and who aggressively carries his selling policy into the homes of the people rather than he who waits for the public to seek him out. We feel that the abnormal growth in prosperity and demand in the Northwest will more than care for any increased production in our own or other lines of merchandise that may be in demand.

E. F. DROOP & SONS CO., Washington, D. C.

We are looking forward optimistically into the future. Of course we will pass through a period of reconstruction that will be more or less trying, but this country is too enterprising, prosperous and efficient in every direction to lie down in the face of trouble (and, for that matter, in the time of trouble, as we have recently witnessed).

As far as the policy of the house is concerned we intend to purchase liberally and conservatively; we shall also be careful about extending credit terms—shall insist upon well-proportioned cash payments in connection with our instalment sales and will keep a sharp lookout on our collection department. If every dealer will do this and maintain an intelligent advertising campaign, he need have no fear or worry.

F. R. ERISMAN, Columbia Co., Dallas, Tex.

The cessation of hostilities means to Texas a still greater increase in the sales of talking machines and records. The high prices which the farmers of Texas are sure to get on crops and the new developments, especially in the oil industry, will bring a greater wave of prosperity to Texas than she has ever known before. Although we will realize in the year of 1918 a greater sale for talking machines and records than ever before, yet I look for the year of 1919 as a record year.

Texas, being purely an agricultural State, will not be affected by cancellations of contracts in munition plants. A scarcity of labor will prevail, thereby keeping up the high wages. It is up to the dealer to stock up on both talking machines and records in order to meet the demand that is sure to exist in the year of 1919.

MICKEL BROS. CO., Des Moines, Ia.

Indications point to the fact that the year of 1919 will be the biggest and most successful year in the history of ourselves as jobbers, and our dealers. The State of Iowa has always shown a steady increase in the amount of Vic-

(Continued on page 54)

**PRESS THE BUTTON—
THE MOTOR STARTS**

No Winding, No Noise, No Spring Trouble
THAT IS

THE VEECO WAY

The improved VEECO electric motor is designed primarily and exclusively for Talking Machines. It is smooth and noiseless in action and practically fool-proof. Standard models run on any voltage from 100-125, A. C. or D. C., without adjustment. Other models for any voltage from 6-250. Furnished mounted on 12 or 12½ inch mahogany board ready to install, or without board, all ready to mount on such board as used by the manufacturer.

With the VITRALOID turntable, supplied with the motor, it makes a complete motor unit for high class machines.

Send for a sample NOW and place your order at once for early delivery.

THE VEECO COMPANY
248 Boylston St. Boston, Mass.

THE ORIGINAL PRODUCERS OF A COMPLETE ELECTRIC DRIVE
FOR TALKING MACHINE MANUFACTURERS' USE

PROSPECTS IN TALKING MACHINE INDUSTRY DURING PERIOD OF READJUSTMENT—(Continued from page 53)

trolas and records distributed and resold; in fact, during the year of 1914 the State of Iowa showed an increase of 125 per cent. over and above any other State in the Union in the distribution of Victor products. This remark can be demonstrated by reference to the Victor Co.'s files, at which time a circular letter was sent out to the trade in general.

Business has never let up since that period, and although the increase may not reach that magnificent proportion, due solely to the inability of the factory, through war conditions, to increase their output, we still feel that our increase year by year has steadily grown, and had conditions been normal during the year of 1918 we would have unquestionably closed one of the biggest years in our history as jobbers.

Relative to the general clientele of dealers in the State of Iowa, they all show magnificent increases, especially regarding the record situation, as they have awakened to the idea that the sale and promotion of records is as important as the promotion of the sale of Victrolas.

In conclusion let us state again that we have every confidence that the year of 1919 will be the biggest year in the history of the talking machine business in general. As far as the State of Iowa is concerned it will be the biggest and most successful year in the distribution of Victor products.

LOUIS BUEHN CO., Philadelphia, Pa.

We hesitate to make any forecast regarding prospects for 1919, for the reason that any development is so entirely controlled by factory conditions.

We are firmly convinced, however, that prospects for business are the best that we have ever had in the section where we sell goods, and if the Victor Co. can come through with a production of machines and records greater than at any time in the history of the business, they will be purchased by the dealer and sold

to the general public without a shadow of doubt.

The writer is of the opinion that a tremendous increased production on the part of the Victor Co. will be readily absorbed by the public for several years to come.

LAMBERT FRIEDL, Local Manager Columbia Co., New York

On the very day of Germany's surrender the phonograph industry has won. Expansion on the greatest imaginable scale is ahead of the New York territory, in which intelligent effort and willingness to do things the "new way" will count.

WILLIAMS-DAVIS-BROOKS & HINCHMAN SONS, Detroit, Mich.

At this time we are having a heavy demand for phonographs and records and, while a certain number of the large manufacturing concerns in this vicinity, on account of the cancellation of war contracts, have been obliged to lay off a large number of employes, we believe this will be but temporary, and in our opinion after the few weeks have elapsed which it will necessarily take for the manufacturers to rearrange their plans, we look for a large increase in business. As a matter of fact, the amount of our total volume this year depends entirely upon our ability to obtain the goods, as we have no difficulty in disposing of all that is shipped us.

PENN PHONOGRAPH CO., INC., Philadelphia, Pa.

It would seem that the sudden termination of the war caught business off its guard and unprepared for the quick change. Such factories as were engaged in war work will necessarily be slower to resume their normal stride than those industries whose business was only curtailed.

As relating to our business, we expect a quick recovery to normal deliveries in records, perhaps in six months. Regarding machines, we

believe it will take a year to secure enough machines to fill dealers' orders and give them some floor stock.

To Victor dealers we can say we believe their future business will make that of the past look like a "piker's game." With the factory going at top speed, the jobbers having improved and expanded their facilities, the dealer more alive to the possibilities and greater accommodations for handling the business, and a waiting, buying public with plenty of money and a desire to spend it, what else can be expected but prosperity. Mr. Dealer, the golden days are coming.

W. TERHUNE, Columbia Co., Atlanta, Ga.

To say that we are going into 1919 with prospects for the biggest and best business in the Southeastern States that the Columbia Graphophone Co. has ever known is a conservative statement. Business conditions in our territory are on a sound foundation. There is every reason to believe that this section of the South will suffer less from whatever temporary reaction takes place in transferring business from a war to a peace basis than any other section of the country. The South is more nearly on a self-sustaining basis than ever before. Its principal crop, cotton, is needed by the entire world. There is every reason to believe that it will command a good price for a number of years. What is even more important, Southern merchants and Southern farmers have paid up their debts, and I do not believe that they will ever go back to the old system of doing business on long terms.

CRAFTS-STARR PHONOGRAPH CO., Richmond, Va.

From observations and from the experience of the present year, which is drawing to a close, we cannot help but be enthusiastic as we approach the new year and the new conditions which we are facing.

There are no jobbers of standard talking ma-

(Continued on page 56)

STRADIVARA

Art Phonograph

PATENTED

"KNOWN FOR TONE"

The Phonograph you expect to sell with satisfaction must have tone, artistic cabinets, thorough workmanship inside and out, mechanical perfection, and an organization back of it to inspire confidence. We have built into our Instruments all that is good, but Tone cannot be built, that is the creation of genius not mechanics.

From \$60.00 to \$250.00 with substantial discounts on a strictly one price policy, fully guaranteed.

Full advertising service, of course.

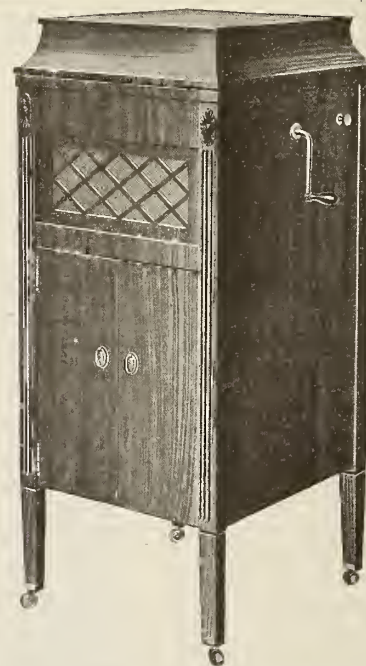

No. 95 — List Price \$95.00

The Compton-Price Company, Ltd.

Coshocton, Ohio



THE volume and character of a dealer's talking machine trade depend on the character of his product.

There is a quality and character to Nightingale phonographs that is distinctive and unmistakable. These attributes apply to both tone and case.

The Nightingale equipment is the best that money can buy. The Stephenson precision made motor and the Scotford tone arm and reproducer constitute trouble-proof, correct tone-producing features that commend themselves to discriminating buyers.

The cases are made in our own factory by skilled cabinet workers. Perfection in detail and finish is always insisted on.

1919 is going to be a big year for the talking machine trade. I should like personally to discuss with a limited number of AI dealers the advantages of the Nightingale as a result producing, profit making, prestige increasing line for 1919.

Harry B. Wolfper
President

Nightingale Mfg. Co.
422-426 North Armour St., Chicago, Ill.

PROSPECTS IN TALKING MACHINE INDUSTRY DURING PERIOD OF READJUSTMENT—(Continued from page 54)

chines and phonographs who have been able to take care of their orders with any degree of satisfaction. Virginia, North and South Carolina are in excellent shape financially. There is much money in circulation and the people as a whole of these respective States are better able to buy that which they desire and will do so during 1919.

The possibilities for doing business profitably are indeed encouraging. The retail trade must be good, if we are to judge from the manner in which orders are being received by us, though we are not in the retail phonograph business.

As an indication that the coming year will see good business, we have received orders from many of our best dealers for January deliveries. We are already booking orders for 1919 and I believe that the talking machine trade will have seen the greatest year in its history when it will have passed through the coming year.

No doubt there will be a number who will venture into the manufacture of the cheap talking machines during the coming year. Many have gotten this "bug," but that will only have a tendency to increase the sale of the higher class machines, and the dealer who sticks to the standard lines will eventually win out in the long run. There may be a little more profit in the selling of the assembled phonograph, but the ultimate results are disastrous to the dealer, for in the majority of the cases the dealer sooner or

later is unable to obtain the parts by reason of the assembler having dismantled his plant and having become extinct.

The reports which we receive from our representatives on the road indicate that the new dealers who have qualified this year and have tried the phonograph business like the game, and they are going to make a greater effort during the coming year. All of this will have a tendency to create a greater demand, and with peace in sight we see nothing but prosperity facing the talking machine trade during 1919.

G. E. MICKEL, MICKEL BROS. CO., Omaha, Neb.

To say that I am optimistic over conditions that exist in our territory at the present time and future prospects puts it mildly, for I believe any merchant in any line, situated in the Central West, cannot help but view the future in the same way.

This section of the country was the least interrupted of any because of war conditions. While the building of our national army and those who were taken into the service have made labor scarce, yet the return of this labor will affect us only in the most favorable way, as we have places for all who left and more, too.

In Wyoming, Iowa, Kansas, the Dakotas, Missouri and Nebraska, the garden spot of the world, the people have had, during the last few

years, immense crops and the farmers to-day are well-to-do, and when you stop to consider that in Nebraska alone the normal wheat crop this year will be from eighty to one hundred million bushels; that the normal corn crop is from two hundred to three hundred million bushels, with prices that were unheard of heretofore (and these will be harvested in the next few months), that the prices of hay and alfalfa, of which we are big producers, are tripled; that we have a beet sugar industry that produces normally one hundred million pounds; that Omaha, which is the center of this territory, has the largest butter producing industry in the world, which, of course, is attributed directly to the farms in Nebraska; that 80 per cent. of the potash, an article of such moment to our people (and is being produced by the United States at the present time in quantities equal to Germany in the pre-war period); that 80 per cent. of this is being produced in the State of Nebraska.

All this coming at a time when our farmers are stockholders in the national banks, and in many instances owners of the banks, it gives you an idea of the possibilities for the marketing of our particular product—Victrolas.

Assuming that the factory will be able to produce goods in sufficient quantities we will have the greatest talking machine year that we have ever dreamed of.

I know of a farmer in the western part of the State who has 320 acres of land and he told me that his thirteen-year-old boy, with three or four cows and a small cream separator, made the entire living for the family and raised last year 6,000 bushels of wheat, with the help of one man part of the time, and 3,000 bushels of corn, besides two carloads of cattle and a bunch of hogs.

Imagine what that means to a man, with the present prices of produce and his living all provided. He has no place to spend his money except in the improvement of his home. This offers a wonderful market for anything that will add to the pleasure and comfort of living, and music, which adds so much to the education and pleasure of home life, will have first call.

So in face of all this, how could any man, connected with the talking machine trade in this section, be anything but optimistic?

THE OHIO SALES CO., INC., Detroit, Mich.

What dealers we have had expressions from are very optimistic and the outlook in Michigan and Ohio for 1919 for the talking machine business is very encouraging. Labor conditions will govern business to quite an extent, but these are good in this section and the general impression is that they will continue so. During the war period the demand far exceeded the supply, and we are satisfied there will be as great or more of a desire to buy, but sales will be governed by the purchasing ability of the public.

PHONOGRAPHS, INC., Atlanta, Ga.

We believe the prospects for the phonograph business for next year are better than ever before. We have not been in this territory long enough to be able to give an accurate statement of conditions, but we are preparing to do double the volume of business next year we will receive during the year just ending.

Of course, in our section much depends on the cotton crop, as to the outcome of the crop itself, and then as to the prevailing prices in the fall, but we do not think there is much chance for a great reduction in price of cotton for several years to come.

ELECTRIC SUPPLY & EQUIPMENT CO., Albany, N. Y.

To interpret our views correctly you would have to run them in rose-colored type, as we believe that the retail dealer who has an established agency for a good quality talking machine and a good record will be in position this coming year to at least double his business of previous seasons.

All high-grade talking machines and records have been exceedingly hard to get for the past



THE IMPROVED No. 10



RECORD BRUSH



NICKEL PLATED 35 CENTS

Patented Sept. 26 and Oct. 2, 1906
Sept. 10, 1907, and Nov. 27, 1917
Others Pending

GOLD PLATED 75 CENTS

For Victor Victrolas

Automatically

CLEANS RECORDS

and insures

A CLEAR REPRODUCTION

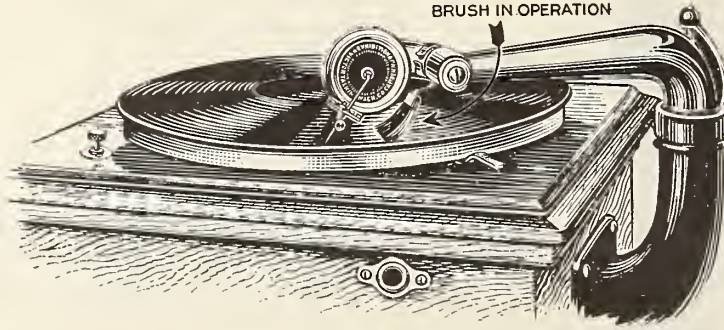

An article needed by every Victrola owner

Order a Supply from Your Distributer

Manufactured by



Blackman
TALKING MACHINE CO.
97 CHAMBERS ST. NEAR CHURCH ST. NEW YORK



Victor Distributers

Christmas—and Peace! What a combination of ideas that strike deep into the desire of the human heart for expression in music.

**Columbia Graphophone Co.
NEW YORK**



PROSPECTS IN TALKING MACHINE INDUSTRY DURING PERIOD OF READJUSTMENT—(Continued from page 56)

two years. Dealers have taken finishes, styles and selections that were not needed by their trade, and have sold designs that the general public did not care for but accepted, merely because they could get nothing else.

With the economic change to peace conditions and the lifting of the Government's ban on the manufacturers, most talking machine companies will produce better and more attractive instruments than ever before. We also know that many millions of dollars will be spent by the leading companies in advertising.

We have always found it to be our experience that the more live dealers there are in a town the more each individual dealer sells. We do not believe that any real agent need have any fear of too much clean competition in his locality, providing he is handling a machine and a record that sell on quality instead of price.

The public is fast being educated in quality goods in talking machines—the day is past when any manufacturer can put out a box and a horn and sell it as a phonograph.

W. G. WALZ CO., El Paso, Tex.

As to present conditions in our territory we can say that since the war our orders for Victrolas and Victor records have been better than we have ever seen before. The general shortage of Victor merchandise with the unusual demand, of course, is making a decided shortage, and we are able to fill only a small proportion of the orders offered us. The general outlook is all that we can ask, and we believe our dealers will take many times the amount of Victor goods we expect to be allotted in the next several months.

F. F. Davidson, COLUMBIA CO., Cincinnati, O.

The outlook for the talking machine business for next year is to be measured by one's own attitude and plans for activity. Plans cannot be too big if backed up by intelligent action. I

know nothing of the plans of the manufacturers, and speak only of the sales outlook. I think the demand for phonographs will depend more upon educational activity in the future than it has in the past. The first demand was based upon either curiosity or a sort of pride that led one to desire something that others did not possess. This demand has passed, and a new condition obtains.

This new condition brings us face to face with a most promising era. The advantage will be in a drive for better business and the sale of better types of instruments. The tendency toward better types the past few months has been very marked. This will grow, and is growing rapidly. The dealer who continues to play at the game in the same old way is going to become more and more discouraged. He must have plans for systematically and aggressively pushing to the front *musical instruments* of the first rank instead of just phonographs. It is time to stop playing at the game and get in "teeth and toe nails" and "play the game."

The possibility for record business next year and in the future is even more in the direction of better records, and the need for record sales girls instead of record clerks is far greater than ever. Popular records are sold through general publicity, but good records are sold through intelligent demonstration. This is the need for the future, so business in 1919 will be more what our own activities make it than otherwise.

Music as an avenue to human hearts will grow as human beings are brought into touch with it, therefore prospects are bright indeed for the dealer who knows the records and can make the application. Cincinnati Columbia interests are very happy over the wonderful prospects for next year.

THE PHONOGRAPHS CO., Kansas City, Mo.

I look for the greatest period of holiday buying during the month of December which this

country has ever known in its history. Our November business in Kansas City was very wonderful and December promises to be still better. Regarding the next year we would say that business in my estimation will depend entirely upon our ability to get goods.

TALKING MACHINE EXPORTS GROW

Exports, Including Records, for Nine Months Ending September 30, Totals \$3,197,610

WASHINGTON, D. C., December 6.—In the summary of exports and imports of the commerce of the United States for the month of September, 1918 (the latest period for which it has been compiled), which has just been issued, the following figures on talking machines and records appear:

The dutiable imports of talking machines and parts during September, 1918, amounted in value to \$1,186 as compared with \$14,135 worth, which were imported during the same month of 1917. The nine months' total ending September, 1918, showed importations valued at \$250,575, as compared with \$344,975 worth of talking machines and parts imported during the same period of 1917.

Talking machines to the number of 2,364, valued at \$58,744, were exported in September, 1918, as compared with 6,437 talking machines, valued at \$191,157, sent abroad in the same period of 1917. The nine months' total showed that we exported 51,389 talking machines, valued at \$1,535,966, as against 63,659 talking machines, valued at \$1,606,555 in 1917, and 45,210 talking machines valued at \$1,128,602, in 1916. The total exports of records and supplies for September, 1918, were valued at \$175,453, as compared with \$150,554 in September, 1917. For the nine months ending September, 1918, records and accessories were exported, valued at \$1,661,644, as compared with \$1,330,759 in 1917 and \$823,858 in 1916.

EXACT SIZE



WHY NOT ORDER A SAMPLE

FLETCHER Reproducer and HEAR the improvement it makes in tone and detail of your records? :: ::

Samples \$4.00. Satisfaction guaranteed or money refunded

FLETCHER-WICKES CO.
6 E. LAKE STREET CHICAGO, ILL.

OVERCOMING INFLUENZA EFFECTS

C. W. Lindsay & Co., Ltd., Montreal, Adopt Clever Advertising Scheme to Keep Business Going Along During the Quarantine Period

MONTREAL, CAN., December 2.—During the recent influenza epidemic in this city C. W. Lindsay & Co., Ltd., overcame in a large measure the effect of the epidemic on their business by running a special, and most interesting series of advertisements in the local papers. The series, which ran for a week, was entitled "The Adventures of the 'Average' Family."

The first ad represented the cover of a book with the title plainly displayed. Then there was a chapter devoted to each night of the week, the first showing the family seated around listlessly and irritable with no form of amusement available. Next was shown the introduction of the phonograph into the house and the family much interested. Tuesday night the young people had a dance. On Wednesday the father stayed home from his lodge to enjoy the music. Thursday night was another hop, and Friday night was spent in making up a list of desired records.

The advertisements occupied a space of about twelve inches deep, three columns wide, attracted a great deal of attention, and, most important of all, brought real business.

RECORDS FOR CHRISTMAS SEASON

The Victor Record Supplement for December reflects to the fullest extent the holiday spirit and is made up entirely of a list of "best sellers" for the Christmas season. The records listed are not by any means confined to Christmas carols, or similar music, but also include standard records of particular interest by prominent artists, such as, for instance, the "Minuet in G," played by Paderewski; "Harlequin's Serenade," played by Zimbalist; "Adeste Fideles" and "Keep the Home Fires Burning," by McCormack, and scores of other numbers of actual interest. There are also special lists of dance, instrumental and vocal records for the consideration of Christmas buyers.

Have You Tried This New Tungsten Stylus?

The Liberty Stylus

This semi-permanent needle which is a scientifically perfected tungsten stylus, and not an ordinary steel needle, plays from 100 to 300 records *perfectly*. It is manufactured in full, medium and soft-tone, and is marketed in packages of three needles to a package; 50 packages in a box.

The Liberty Stylus is the only semi-permanent needle that can be used, removed at any time, and replaced in the needle holder, without lessening the tone quality or damaging the record.

Immediate Deliveries Guaranteed

Free Samples to the Trade

LIBERTY STYLUS CO., 149 Kirby Ave., West DETROIT, MICH.

KEEPING THE CUSTOMER INTERESTED INTERESTING VIEW OF STOCKROOM

George S. Dales, Victor dealer, of Akron, O., recently instituted a scheme that has netted him unusual business returns, especially in record orders. He sent a post card to a large mailing list, offering to oil and inspect Victrolas free of charge. Within a few weeks his force had not only oiled some five hundred machines, but had repaired a large number at proper charges. In this way they brought the owners of these idle Victrolas back into the record market, says The Voice of the Victor.

The Otto Heineman Phonograph Supply Co. recently received from one of its patrons an interesting photograph showing a view of its



Shows Stock of Heineman Motors

stockroom and one of the company's expert mechanics testing the Heineman motors which this company uses exclusively. This manufacturer makes it a point to carry on hand at all times a good-sized stock of motors, and the thorough tests that its experts make enables the company to offer their machines to the public with the assurance that the motors will give absolute satisfaction in every detail.

APPOINTED ASSISTANT MANAGER

George H. Williams, formerly manager of the Seattle branch of the Columbia Graphophone Co., New York, has been appointed assistant manager of the company's Cincinnati branch. Mr. Williams will bring to his new post an invaluable knowledge of the company's merchandising plans and policies, having been for a number of years associated with this company. He has a host of friends in the trade and in his new position will undoubtedly render important assistance to F. F. Dawson, manager of the Cincinnati branch, who is achieving splendid results in that city.

FOREIGN RECORDS IN ONE BOOKLET

There has recently been issued a special folder of the best sellers among the Victor records in a number of foreign languages, including Bohemian, Hebrew, French, Greek, Portuguese, Italian, etc. Each page in the booklet is devoted to from four to a half dozen records in some foreign language, and having them listed in one volume should prove a genuine convenience to the dealer. The usual descriptive matter follows the title of each record.

Delpheon
the
Incomparable

A tone that is ineffably exquisite—not phonographic

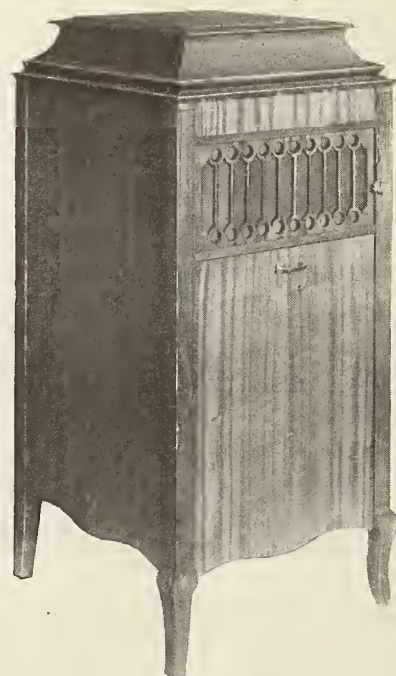

Delpheon \$150 Model

THE DELPHEON COMPANY
BAY CITY :: :: MICHIGAN
OR WRITE TO DISTRIBUTORS



**A Talking Machine
Needle Without a Fault
Rush Coupon for FREE SAMPLE!**

Something brand new! Something infinitely more pleasing and satisfying! A real scientific discovery. A graphophone needle that draws forth such beauty and clearness of tone as has never been equalled. A needle that *doubles* the value of the phonograph—that *trebles* sales of needles! records!—machines!—that *quadruples* your profits! That will make your

store stand first and foremost in your locality. Don't put off! Send coupon NOW for *free* samples and price of the latest sensation—the greatest of all phonograph needles, the *Tonofone!*

BETTER STILL: Order a supply today. Increase your *Christmas* Sales of machines and records. We will give you the right wholesale price. Our *money-back-guarantee* protects you **ABSOLUTELY.**

“*7*”
Tonofone”

The Talking Machine Needle That Puts Magic in Music

The Tonofone is made on entirely new principles, of entirely different materials. Instead of skipping or jumbling many of the finer microscopic undulations vibrated into the groove when the record was made, the smooth, resilient, platinum-like Tonofone point gets them all.

Nor does this wonderful needle dig into and mutilate the walls of the groove and so impair the record itself and the volume and quality of the reproduction. On the contrary, it preserves and prolongs the life of the record.

It transmits each separate tone in all the fullness and quality of the original rendition. It loses nothing—confuses nothing. It marks a dis-

tinct advance in phonograph music—a new epoch in the phonograph world.

Gone is the scratch—the twang—the squeak. Gone is the last lingering blemish to phonograph music! All is eliminated by the Tonofone. All is replaced by a beauty, a clearness, a matchless and mysterious *purity* of tone that has amazed listeners everywhere—that can be produced, positively, by *no other needle.*

Tonofone needles play all records, both vertical cut and lateral cut. Can be used on all modern phonographs and talking machines. Each needle plays from 50 to 100 records *faultlessly!* Sell at retail—4 for 10c in attractive package, 100 packages in a display carton.

**Don't Be Hide-Bound by Precedent!
Blaze New Trails—Sell What the People WANT!**

Be progressive! Be alive to fresh opportunities! Get in at the *beginning*—when ideas are *new*—when sales and profits are *luscious.* Put Tonofone needles in stock and sell the people what they want. One demonstration will suffice! Manufacturers, dealers, critics and public all crazy about Tonofone results. Send the *Coupon* and see for yourself.

Money-Back Guarantee If, for any reason, you do not find Tonofone needles as represented, and entirely satisfactory, you may return them at our expense and we will refund full purchase price.

PROMPT DELIVERIES No sales-losing *delays*—no profit-losing *waits*—not when you order TONOFONES. Immediate deliveries anywhere.

FREE Show-Me-A-Tonofone Coupon

Name.....
Address.....

Gentlemen:—Without obligation to us, send to above address samples of TONOFONE Needles, prices and full details of selling plan.
R. C. WADE CO.
29 S. La Salle St.
CHICAGO





Christmas records for the kiddies! Remember the little folks in your selling. Every tree ought to have some Columbia Children's Records.

**Columbia Graphophone Co.
NEW YORK**

KANSAS CITY TRADE HANDICAPPED BY STOCK SHORTAGE

Demand Greater Than Ever Before in History Is Report of Leading Jobbers and Dealers—Everyone Pleased at Lifting of Restrictions and Possibility of Getting Increased Stocks

KANSAS CITY, Mo., December 5.—November has been a record month in the talking machine business, in so far as demand is concerned. The demand has been greater than ever before in the history of the talking machine is the report of nearly every dealer. On the other hand, the supply is more limited than ever before. With Christmas nearly a month away, nearly every machine in stock has been sold or put away for Christmas delivery. December is generally considered the biggest month in the whole year, but there is no stock left to sell this year.

A. A. Trostler, manager of the Victrola department at the Schmelzer Arms Co., reports a very fine business, but finds a serious handicap through the shortage of merchandise. "We are willing to wait, however, and let conditions adjust themselves," said Mr. Trostler. "We cannot expect any relief before Christmas, but I believe that at least by February we can expect to receive some new merchandise, and as soon as it is received we will do some real business again."

The Victrola department at the Jones Store Co. has had a wonderful November business, although there has been the same shortage of merchandise. "Practically every machine we have is sold for Christmas delivery," said Miss Williams, who has charge of the department.

Miss Gladys Etherton has been added to the salesforce in the department.

"It is hard to tell whether the demand is so much greater this year than previously at Christmas time, because there is such a shortage of stock among all the dealers," said Mr. Hall, manager of the Hall Music Co. "For instance, there are several dealers who handle Victor records, say six. If a customer wants a certain record, he will try each place in an effort to get the one he is looking for. Thus the demand is increased six times at each place. Had the stock been complete, only one store would have been visited. We have had many times the number of calls for both records and machines this season, but we attribute it partly, at least, to this fact. We have several other machines besides the Victrola, but it seems that because there is such a shortage people are demanding it more than ever."

"If we had merchandise on hand to supply the wants of every customer, we couldn't possibly handle all the trade," said J. B. Pierce, manager of the Victrola department at the J. W. Jenkins' Sons Music Co. "People are demanding musical instruments this year as never before, and they are demanding the very best grade of merchandise in almost every case. The main reason for this is because the average man

is making more money now than ever before and is in better circumstances, in spite of the fact that all prices are higher and there have been so many calls for war funds."

Charles K. Haddon, vice-president and treasurer, and Ralph L. Freeman, secretary, of the Victor Talking Machine Co., were visitors to the trade recently in Kansas City.

Miss Marion Biscoe, of the record department of the J. W. Jenkins' Sons Music Co., is very seriously ill with influenza at her home in Camden Point, Mo.

"It is very difficult to make any statement as to business conditions at present," said Miss Surendorf, manager of the Kansas City branch of the Starr Piano Co. "If we had about four hundred times as much merchandise, enough to satisfy the demand, we could report a very excellent business. Our wholesale business has been very good, but of course handicapped by shortage of merchandise. We are expecting a relief some time after the first of the year, as soon as the factory can get back on a before-the-war basis."

E. Robinson, salesman for the Mandel Talking Machine Co., was a visitor to Kansas City last week.

George D. Standke, manager of the Victrola department at the Geo. B. Peck Dry Goods Co., reports a very fine business and says people have bought exceptionally early for Christmas this year in accordance with the Government's request.

Business at the Brunswick Shop has been exceptionally good. November was a record month and December promises to be even better. Though the demand is very great and increasing, Mr. Chestnut, manager, does not anticipate any serious handicap through lack of goods.

J. W. Watson, manager of the Edison Shop, reports a very fine business. November business was better than ever before in corresponding months. An increase of nearly 40 per cent. was realized. "There has been a noticeable increase in the number of cash sales, too," said Mr. Watson. "It has always been our policy to employ only experienced help. I believe it pays in the long run, although we do have to pay them better wages. When we hand a customer over to one of our salesforce, we are confident that if it is possible to make a sale it will be made in a most satisfactory manner. We can absolutely depend on our force and I attribute the greater part of our success to this very fact," continued Mr. Watson.

Among the five new sales persons added to the force at the Edison Shop are the following: I. W. Foster, formerly with the Phonograph Co. of Helena, Mont.; Mr. Hightower, of the Phonograph Co. of Oklahoma City, Okla., before accepting this position; and Weed Heind, formerly traveling salesman for the Phonograph Co. Miss Pointer, who had been ill since last February, has returned to her position in charge of the record department.

C. W. Burgess, traveling salesman from the Edison factory, was a visitor to the Kansas City trade recently.

MELOPHONE MOTOR

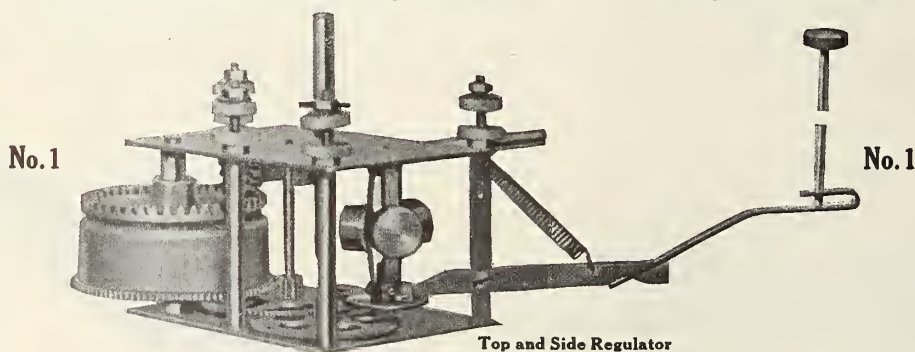

Top and Side Regulator
COMPLETE WITH 10-INCH TURN TABLE

Simple in construction, the most satisfactory and durable of all small motors.

Will play two ten-inch records with one winding.

Three years' successful record as the best single spring motor manufactured.

Immediate Deliveries

Sample \$2.00

Write for Quantity Prices

Melophone Talking Machine Co.

380 Lafayette Street, New York

DOMESTIC CORP. IN LATROBE, PA.

Well-Known Philadelphia Institution Makes Change of Location—Joseph S. Truitt the New President of This Company

PHILADELPHIA, PA., December 4.—Announcement is made by the Domestic Talking Machine Corp. of the removal of their headquarters from this city to Latrobe, Pa. An entirely new personnel is directing the destinies of the corporation



Joseph S. Truitt

and many plans for the future of this well-known line are being made.

The new president is Joseph S. Truitt, a mechanical engineer, who has given much attention to the development of sound instruments. As consulting engineer with one of the large talking machine motor manufacturers he specialized on the talking machine and its problems.

Mr. Truitt is an executive of high ability, and, with the assistance of E. Bauer, who was connected with the Domestic Talking Machine Corp., under its former management, and who is well and favorably known through his connection with the talking machine industry for a period, the future of the Domestic Talking Machine Corp. is very promising.

TRADE NEWS FROM INDIANAPOLIS

Dealers Deeply Concerned Over Record Stock to Meet Holiday Demands—Increasing Employment of Women—The News of the Month

INDIANAPOLIS, IND., December 5.—Local talking machine dealers are looking forward to the holiday business with only one apprehension, that they will not be able to get enough records and machines to supply the demand. Even those dealers who were far-sighted enough to order heavily last spring say their reserve stock will not hold out against such demands as they have received the last two months.

W. E. Pearce, manager of the talking machine department of the local branch of the Brunswick-Balke-Collender Co., says that the Brunswick dealers all over the State are reporting good business.

Ben Brown, manager of the Columbia wholesale branch, reports that the biggest worry is to satisfy the demands of the dealers for goods. Sam Lemberg, of the foreign record department of the Columbia Co., was in Indianapolis for several days last week. O. A. Wilkinson, manager of the Dictaphone department, attended the conference for the Columbia Dictaphone men in New York last Monday.

J. L. Peter, manager of the Columbia retail store, says that the November business showed a remarkable increase over previous records.

C. P. Herdman, manager of the talking machine department of the Baldwin Piano Co., reports that the Columbia business for the last two months has been three to four times as large as last year's business for the same period. The Windsor talking machines in the art models, which the Baldwin store has recently begun to

sell, are also meeting with a strong demand.

At the Stewart Talking Machine Co. store business is only limited by the amount of machines and records that come in from the factory.

A. J. Kendrick, of the Brunswick-Balke-Collender Co., visited the Brunswick Shop last week.

H. E. Whitman, manager of the talking machine department of the Pearson Piano Co., reports that business in the Cheney, Victor, Edison and Vocalion machines is good.

A. H. Snyder, manager of the Edison Shop, says that his experiment in "salesladies" for the Edison machines has proved successful. Mr. Snyder says he was skeptical about employing women when the war took away his men, but that the records made by his saleswomen have changed his mind.

Miss Ida Gardner, assisted by Harold Lyman, gave an Edison tone test in the Riley room of the Claypool Hotel here November 15. The concert was under the auspices of the Edison Shop and the large audience showed its appreciation of the wonderful demonstration of the quality of the Edison machine.

BUYS OUT PREMIER CO.

Independent Talking Machine Co. Purchases Premier Talking Machine Co., of Williamsport, Pa.—Plan a Policy of Expansion

The Independent Talking Machine Co., New York, has purchased the Premier Talking Machine Co., of Williamsport, Pa. No announcement has been made as to the amount involved, but the Premier Co. was a large organization and was well known in the field. It is understood the Independent people contemplate several other moves in the near future, which will place them in a fine position to handle a greatly increased business after the first of the year. They just recently leased space at 325 Lafayette street, which adds a substantial addition to their New York floor space.

TIME FOR RESOLUTIONS

Isn't it time for members of the talking machine industry to be considering those resolutions for the New Year?

"SMILES"

Sells itself doesn't it?

Doesn't require any exertion at all. Don't need salesmanship for that.

There are many so termed "slow sellers" that are good records and do not move because no effort is made to sell them.

Money lost to you

Perhaps your competitor is getting these profits.

You can get them if you push these records.

The people don't know about them. It's up to you to tell them.

Ask us about these records and we will help you sell them and make more money.

C. BRUNO & SON, Inc.

351-353 FOURTH AVENUE :: :: NEW YORK

Victor Wholesale Exclusively

REG. U.S. PAT. OFF.

Paramount Records

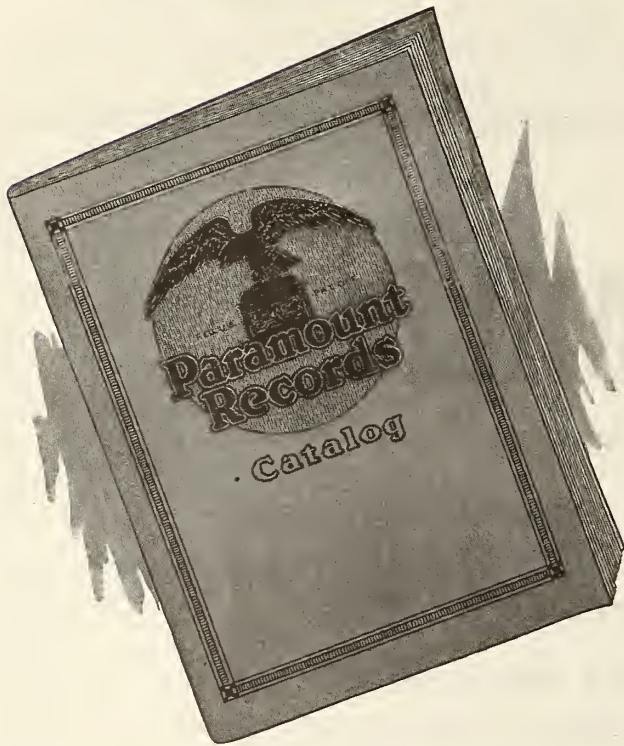

The New Complete Catalog Is Now Ready

Contains a range of the most popular selections of the day.

A catalog of up-to-the-minute all-hit combinations.

No doubtful, dead-stock numbers.

The outstanding feature of Paramount Records is the POPULARITY of the selections offered. There are no weak combinations—both selections on each record are winners. The Paramount catalog comprises only the choicest gems of standard popular sellers in operatic numbers, standard songs, band and orchestra selections, latest dance music, instrumental solos and musical comedy hits especially picked for their ready-selling qualities.

Get your full share of the big record profits. Build a growing trade. Be one of the first to cash in on this live record proposition. Establish your store as Paramount headquarters in your locality.

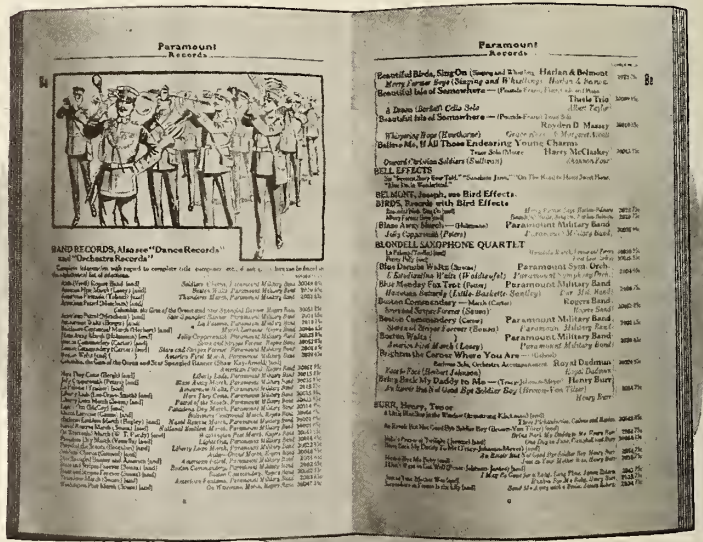

Send Today for this New Complete Paramount Record Catalog

The New York Recording Laboratories, Port Washington, Wis.



Jobbers—Manufacturers

Attractive Proposition
Write for further details

Name _____
Address _____
Phonograph we handle _____

Dealers—

Big Profits—Prompt Deliveries—Quick Sales
Write for full information

Name _____
Address _____
Phonograph we handle _____

BUMPER HOLIDAY BUSINESS LOOKED FOR IN DETROIT

Orders Already in Hand Give Substantial Indication of This Tendency—Record Trade Breaks All Precedents—Hope to Increase Sales Force Soon With Disbandment of Army

DETROIT, MICH., December 2.—A bumper holiday business is talking machine records, and everything connected with the talking machine industry is not only assured but is conceded by Detroit dealers based on one point—ability to get goods. Unless some concerns find some way to increase their stock of machines they are going to be cleaned out of their present stock at least a week before Christmas, and in this connection we refer to some of the largest dealers in Detroit. Their stocks are absolutely depleted—they are right down to rock-bottom and just trusting to luck that something will happen to bring them more goods. Whether or not some of the talking machine companies can get their factories in shape to increase production, make shipments by express and get goods here in time remains to be seen—it is very questionable.

C. H. Grinnell, of Grinnell Bros., Victor jobbers, recently made a trip to the factory and called on some of the big Eastern jobbers in search of talking machines, but without any results. He came back with no encouragement so far as machines are concerned. He says he has a good supply of records on hand. Grinnell Bros. are the only exclusive Michigan jobbers for Victor goods, but they are supplying the majority of Victor dealers in the State besides their own chain of twenty-four stores.

Ed Andrew, of the J. L. Hudson talking machine department, was away the last week in November, visiting the leading jobbing centers in the Middle and Central West in the hope of getting his hands on a large stock of machines. He came back with only slight results. Everywhere he met the same fate—a shortage. The Hudson store is now retailing Victrolas, Cheney and Sonora phonographs, but Mr. Andrew says he has not been able to get enough of anything so far as machines are concerned. The Hudson talking machine department, including records, has shown a tremendous increase and the quota will be smashed to smithereens if the merchandise is available.

Record business is splendid—exceptionally good—and it seems that everything is selling. Patriotic airs, popular songs, dance numbers, comedy selections, and the high-grade records by well known soloists are selling unusually well. Detroit has had an unusual number of world-famed artists in recital since October 1st, and before and after each artist's appearance there has been a brisk demand for their records. Each record manufacturer has received a good share of the business. Among the best known artists were Caruso, Victor artist; Lazaro, Columbia artist, and Anna Case, Edison artist. Besides, there have been a half dozen others, all of whom have a big following. By the crowds attending these recitals, people seem more interested in high-class

music than ever before—even the impresarios admit this.

All of the talking machine stores have been short on salesmen and record girls, but now that the armistice is signed, dealers look for an improvement in the help situation. Already some of the dealers have had letters from former salesmen in service asking for their positions back as soon as they are discharged from the army. The dealers will gladly give them back their positions, as they are sorely needed—the sooner the better.

Roy Dupraw, sales manager for the Clough & Warren Co. store, 84 Broadway, which is a division of the Manophone Corporation, is anticipating a big holiday trade, even greater than last year, which went way beyond his expectations. As shipments are made from the factory at Adrian, Mich., only a short distance away, Mr. Dupraw does not look for any trouble in getting all the goods he can sell.

The H. N. Ness Co. operate the only exclusive Pathé phonograph shop in Detroit. It is located at 73 Broadway, and is about 40 by 125 feet in size, attractively fitted up with sufficient demonstrating booths to handle a big business. The store is open Monday and Saturday evenings regularly and trade is much better than at the former location on Griswold street. Pathé phonographs and records have been coming to the front surprisingly well during the past year.

The Edison Shop, Detroit, some weeks ago inaugurated the biggest newspaper advertising campaign in its history, and needless to say that the money spent has produced good results, as shown by the increased number of sales. Now that the Government is demobilizing its army, we look forward to an early arrival home of R. B. Alling, general manager of the Edison Shop and the Phonograph Co. of Detroit, who sometime ago enlisted and was accepted into one of the officers' training camps in the South.

M. C. Rush, of the Walker-Rush Co., West Jefferson avenue, is developing an excellent Columbia trade among the foreign element of that section. Mr. Rush was for a number of years manager of the talking machine department of the Cable Piano Co. store here before engaging in business for himself and is widely known and popular.

Wallace Brown, exclusively Brunswick dealer, is combining his publicity between billboards and full-pages in the newspapers. And by the way, the Brown emporium is one of the busiest in town. It is certainly doing a lot of business, and Mr. Brown is proving that three things count for success in this business—an attractive store, a good selling organization and proper advertising.

The Henry S. Doran Co., on Michigan ave-

nue, is enjoying the best December business in its history. The Doran store, in all its advertising, emphasizes that "this is the record store." And it is a fact that it does one of the largest businesses in town on records. Bruce Carpenter is manager of the store, Mr. Doran being busy most of the time with other varied interests.

J. H. Goldberg, of the Goldberg Phonograph Shop on Gratiot avenue, who handles both Victor and Columbia goods, continues to specialize on foreign records, carrying as many as 10,000 to 15,000 records in stock at all times of foreign numbers. While some other shops have awakened to the possibilities of getting foreign business, Mr. Goldberg reports that he is doing to-day a greater foreign business than ever before.

Max Strasburg, of the Max Strasburg Co., has a large stock of some numbers on hand and is carrying a larger stock than ever of records, so that he looks for the best holiday business in years.

W. R. Woodmansee is now nicely located in his new store at 936 Grand River avenue, and is practically the only Victor and Columbia dealer on that thoroughfare.

IMMENSE CONTRACT FOR RECORDS

William Filene Sons Co. Store in Boston Contracts for the Purchase of a Quarter of a Million Emerson Records

BOSTON, MASS., November 4.—What is perhaps the largest single contract for records to a retail house ever put over in this country has just been consummated in this city. The credit for this big deal belongs to H. L. Coombs, local manager of the Emerson line, who has sold a quarter of a million Emerson records to the big store of the William Filene's Sons Co., more commonly known as Filene's, which is in the center of the retail section of the city, corner of Washington and Summer streets. The trade will quickly recognize the size of such a transaction when one stops to consider what 250,000 records actually mean when sold to a single retail establishment.

These records are to be advertised immediately in the what is known as the Filene Bargain Basement, and with the reputation of the Emerson back of them they are likely to be quickly disposed of. The Filene house already has a 15,000-lot consignment and the remainder of the order will be shipped immediately. These records represent a large list of popular numbers.

Mr. Coombs has been local manager of the Emerson only about three months, though he had traveled for the company in the New England territory more than a year ago, and a large number of accounts in these six States were opened up by him. He is a man of fine business acumen, keen perception, has a convincing manner and knows human nature, all essential qualities in business.

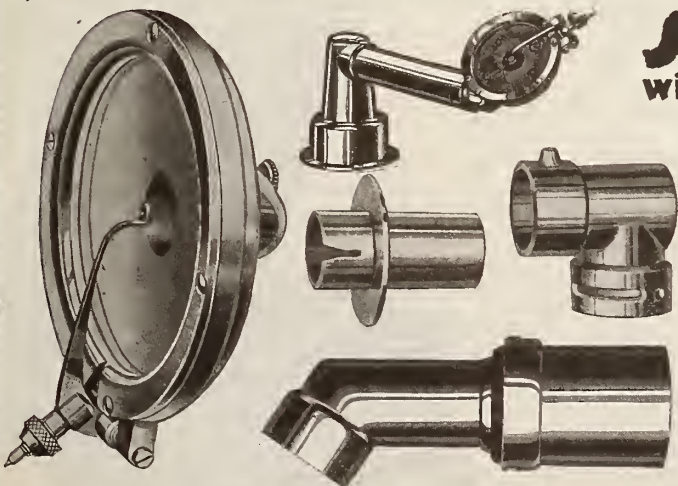

Superior Die Castings

will Cut Your Costs and Increase Your Sales

Tonearm and Reprodncer Parts, Attachments, Turntable Hubs, Motor Governor Discs, Knobs, Piano Player Parts—accurately cast in Aluminum, White Brass, White Metal Alloys or Zelco Metal—ready for nickel or gold plating. We employ a large force of die makers especially skilled in this class of work and operate a large battery of die casting machines of our own design and construction with a capacity of 50,000 to 100,000 castings per day.

Write for
Samples of Work we
are doing in
this line



Send us
your Specifications
or Models for
quotations

Barnhart Brothers & Spindler
Monroe and Throop Streets Chicago Illinois

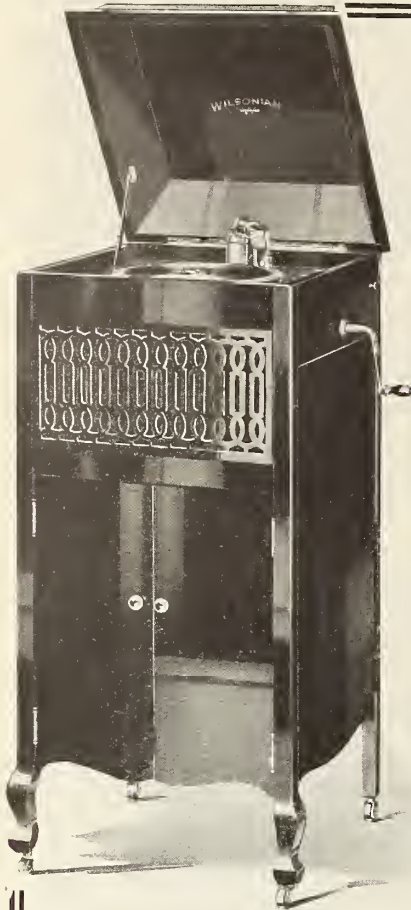

There Is A

WILSONIAN PHONOGRAPH

For Every Home

Wilsonian Phonographs are made in seven new and wonderfully improved models

Retailing at \$45.00 to \$165.00

Each instrument, regardless of its price, is of the highest quality in every detail of appearance, construction and tone refinements.

Each instrument, regardless of its price, is absolutely guaranteed by both this company and our parent concern—Wilson & Co.—the great Chicago packers.

*You Do Not Have to Turn Customers Away
If You Handle the **Wilsonian** Line*

In the complete line of **Wilsonian** Phonographs there is a special instrument to suit every home and to fit every purse. Every prospect who enters your store can be satisfied in every particular if you have the complete assortment of Wilsonian machines ready for his inspection.

*Exclusive **Wilsonian** Selling Features
Will sell Your Customers and keep them Sold*

The **Wilsonian** has many refinements and individualities of style and construction that will appeal instantly to the most critical buyer.

The **Wilsonian** renders the most difficult and intricate musical and vocal selections with wonderful clearness and beauty of tone.

The **Wilsonian** is shown in seven different models, all in conventional designs; famous for their simplicity, elegance and real piano finish.

The **Wilsonian** plays all makes of disc records without it being necessary to make annoying changes.

The **Wilsonian** is absolutely guaranteed. Both this firm and our parent organization—Wilson & Co.—vouch for the dependability of the Wilsonian.

*We are also National Distributors for, and always carry a complete Stock of,
Paramount Records.*

**Write To-day For Our Dealer Proposition
It Means Money To You**

Main Plant
701 North
Sangamon
Street
Chicago



Eastern
Office
25 West
45th Street
New York

Wilson & Co. branches are in all principal cities including:

Pittsburgh	Buffalo	Denver	Kansas City
Boston	Detroit	Omaha	Charleston
Philadelphia	Rochester	Dallas	Memphis
Baltimore	Cleveland	Atlanta	Spokane
Salt Lake City	New Orleans	Los Angeles	Minneapolis



CINCINNATI FACING GREAT PROBLEM OF STOCK SUPPLY

Jobbers and Dealers Striving to Lay Hands on Unexpected Supply of Machines and Records—Optimism Reigns Supreme, Owing to Great Demand, Which Promises to Continue Into New Year

CINCINNATI, O., December 8.—Never in the history of the trade in the Middle West have the jobbers and dealers been wishing the impossible as is the case just now. To the last man they are hoping to lay their hands on an unexpected supply of machines and records, so prosperous was the business in November. Naturally the trade hereabouts expects the demand to hold out until after the holidays.

Take the case of the Columbia house. F. F. Dawson, manager of the Cincinnati district, just back from New York city, knows that he will face a shortage of 2,000 machines by January 1. He has orders in sight and, basing on what the home office will allow him, Mr. Dawson figures that his district will be shy that many machines. During the past few weeks he has had opportunities of taking on exceptionally good accounts, but has been compelled to turn these down because of conditions beyond the control of his office. Mr. Dawson, who took charge of the Cincinnati office last January, is to be aided hereafter by G. H. Williams, former manager of the Seattle branch, who arrived in the city last Friday. His successor on the Coast is Frank Dorian, of the New York City executive office.

Working overtime in order to try to meet the demands is the story of the Crystola Co., of this city. President Alfred Swing this morning stated he was receiving requests for machines from every known method except the aeroplane route plan. "Our success of the past few months," he said, "leads us to believe we are on the road to a prosperous future."

T. Sigman, manager of the Victor department of the Rudolph Wurlitzer Co., is surely happy over the results obtained during the past month. In speaking of the trade developments from a Victor standpoint in the Middle West, he said: "November was an exceptional though excellent month in several ways, due no doubt to the shortage of both Victrolas and records, which is more acute than we have ever experienced. Small Victrolas with cabinets sold remarkably well, and records that we never could have sold during normal times sold almost as good as the best selling numbers ordinarily sell. Cincinnati was the mecca for talking machine dealers this month, and Ohio, Kentucky, West Virginia and Indiana were well represented.

"Jascha Heifetz paid Cincinnati a visit and his two wonderful performances pleased the large, enthusiastic audiences, and it is needless to say that his visit naturally boosted the sale of his records, both wholesale and retail.

"The Victor Talking Machine Co.'s little Vic-

trola folders have created quite a stir amongst the trade, and we look forward to December as being a very productive month (considering the shortage), both in our wholesale and retail departments."

Just a few odd finishes comprise the total stock of the Phonograph Co., Cincinnati, at this writing. F. H. Oelman, manager, stated the local office would make a showing which was beyond the best hopes of the company at the beginning of 1918.

Two tone test recitals are now engaging the interest of the Edison dealers. Glen Ellison, who is making a tour of Ohio, jumped over to Charleston, W. Va., this evening and will return to this State in the morning. Marie Morrisey, assisted by Jacques Glockner, appeared at Dayton, O., to-night.

EXPLOITS STRADIVARA PHONOGRAPH

New Catalog Issued By Compton-Price Tells How This Machine Is Built Like Piano and Violin—Very Artistically Conceived

The new catalog of the Stradivara phonograph, recently published by the Compton-Price Co., Coshocton, Ohio, contains many interesting arguments regarding the merits of this machine. The catalog is highly attractive and has been produced along the most refined and artistic lines. There are illustrated in it the various models of the Stradivara machines, the measurements and other specifications of each model being given on the opposite page to the one on which the machine is reproduced. A copy of the guarantee, given with each machine, is also shown, as well as illustrations of the Compton-Price factory.

Regarding this instrument it is stated in the introduction: "The Stradivara is the very first phonograph to recognize the fundamental value of the basic tone principles of those kingly instruments—the piano and violin," and in another place, "the superiority lies in the new and wonderfully improved tone chamber. True, the sound box of the Stradivara and the perfectly balanced and designed tone arm are superior to others. But we do not stop there * * * but right there at the end of the tone arm—where others leave the tone to shift for itself—the Stradivara begins to differ radically. Instead of using the ordinary metal throat and metal horn, the Stradivara is constructed scientifically in the form of a genuine tone chamber. All metal is eliminated. Instead the tone proceeds down through a perfectly designed and surfaced throat—built of seasoned wood and insulated with felt so as to eliminate all scratching, rattling and other foreign noises. And next the air vibrations are awakened in the patent sound board tone chamber. Instead of just an ordinary metal or wooden horn, you find a scientifically constructed tone chamber. The base or floor of this tone room is a big square sounding board—built of the choicest of old Norway spruce—seasoned and mellowed just the same as you find it in the most expensive pianos of to-day. Open the doors in front of the Stradivara cabinet, stoop and look up at the construction of this marvelous invention, and note its similarity in construction to that of those two world old favorites—the piano and the violin."

Special paragraphs in the booklet draw attention to the tone modifier, automatic stop, ball bearing tone arm, motor and other features of this phonograph.

U D E L L



No. 1415 [Horizontal Shelves] For Victrola IX-A.

Height, 31 in. Width, 19 in. Depth, 22 in. Mahogany or Quartered Oak. Holds 5 Victor Albums. Average weight, crated, 60 pounds.

[If vertical interior is wanted, order No. 415.]

[When felt interior is desired, order No. 415F.]

CABINET BUSINESS IS PLUS

Properly handled it adds to the volume of the first and develops record sales.

UDELL CABINET BUSINESS

will mean more profits and new friends for every dealer who takes proper care of it during 1918. The Udell name means no regrets for either dealer or customer.—Think this over.

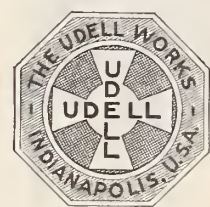

TRADE MARK

THE UDELL WORKS

1205 W. 28th Street
INDIANAPOLIS INDIANA

DEALERS

Offset the Record Shortage! Keep Your Sales-Force Busy! Sell Our Language Records!



French Spanish Italian

ALSO

F.M.C. FRENCH MILITARY CONVERSATION

Cash in now on the

Language Phone Method and Rosenthal's Practical Linguistry

It requires no scientific salesmanship to sell our records. The courses are so simply arranged that the demonstration satisfies the prospect. The French Military Course, 5 Double Discs, and Military Manual (Retail \$10.00) is ideal for Army, Navy, Red Cross

Our Display Signs Sell the Goods Send for Particulars—Prompt Delivery

THE LANGUAGE PHONE METHOD
992 Putnam Bldg., 2 West 45th Street, New York

H. J. SMITH—Jewel Manufacturer

MANUFACTURER OF—Phonograph Diamond and Sapphire Reproducing Points—Recording Laboratory Jewels—Jewel Bearings for Electrical Instruments—Rough Diamond—Diamond Powder—Experimental Work.

Telephone 2896 Market

833 BROAD STREET NEWARK, N. J.

TALKING MACHINE RECORDS AID ART OF GREAT SINGERS

This Subject Discussed Illuminatingly by Miss Spaulding in an Article Specially Written for a New York Paper—Facts Disclosed That Are Not Often Considered by Musicians

Under the heading of "Records Improve Art of Great Singers," there appeared recently in the New York Evening Mail an excellent article written by Miss Pearl Spaulding, of the Aeolian Co., New York, which read as follows:

That the talking machine of to-day is a great teacher is the universal opinion of broad-minded musicians. It is equally true that unbelievable benefits to a singer are being constantly derived from making the records themselves.

Unfortunately, the opportunity of hearing one's voice reproduced is not given to every one. But to the artist who has arrived—and the promising young vocalist whose talent warrants experimenting along recording lines, no course of vocal instruction or coaching is of more practical value than the modern art of singing for records.

It is not an easy thing to make a record. There is something indescribably disconcerting about the blandness of a small horn coming out of a blank wall and waiting like an indiscreet eavesdropper to repeat every sound you make

At some recording laboratories it is suggested that time in experimenting may be saved by practicing into an imitation horn at home, to accustom one to this means of transmission to the recording machine "behind the scenes."

In singing into the horn the proper distance must be observed. One may not yield to an exuberance of temperament and deliver his song with the abandon that ordinary singing permits.

Unless the head is drawn back from the horn during the singing of a high note, which registers greater vibrations than those in the middle register, there will be a disagreeable "blast" on the finished record.

The recording machine is a pitiless critic and reproduces the singer's voice exactly as it

sounds. It is as if the voice were seeing itself in a mirror, or having its picture taken by a too truthful photographer. A voice record admits of no flattering "retouching."

Every little error of tone placement, any characteristic peculiarities of pronunciation or unsteadiness of breath control are brought back to the performer with discouraging fidelity.

At the same time the favorable points are given an equal chance. If there is the slightest reason for the singer's belief that he or she has a good voice, the recorded impression of it will be an infallible witness.

And that is where the great opportunity comes to improve the voice in every way by record-making.

This refers to even the greatest artists, who because they are more human than most mortals are prone to carelessness in their art by reason of the fancied security of their fame.

The bigger the artist the more anxious he is to perfect himself in this particular branch of artistic commercialism—particularly as it means leaving imperishable imprints of a glorious voice that will vanish with the years.

Consider the shock that comes to a noted singer upon hearing his initial attempts at making records to detect subtle faults of diction which had remained undiscovered during many years of success on both the operatic and concert stage.

There follows temperamental excitement on the part of the celebrity and the resolve to go back to the A B C's of vocal principles in a sincere endeavor to project his voice into the recording horn with the greatest degree of naturalness.

Frequently, in his eagerness to learn the rudiments of correct recording, the mighty one has been an interested speculator and listener of popular records being made by an experi-

enced "low-brow" performer, whose years of practice have enabled him to "put over" each word of the song with the necessary clear-cut precision.

For days and weeks the artist may experiment with simple tone tests in front of the horn to establish the proper distance to accomplish the best results for his individual voice.

As greater progress is made the importance of record making is impressed upon him. While records by other singers had always been helpful for purposes of comparison, the test records of his own voice were like so many upward steps toward the goal of a vocal ideal.

And then "one fine day" he steps up before the inscrutable horn, and bearing in mind the lessons he has learned during his course of record study, is able to create a record of his voice with all its natural beauty that satisfies the most severe critic of them all—himself.

ATTRACTIVE DISPLAY SIGNS

Passersby Corner of Riverside Drive and 78th Street, New York, Reminded of Sonora

On the corner of Riverside Drive and Seventy-eighth street, in the heart of the high-class residential district, there is presented for the attention of passersby a beautiful Sonora painted



Sonora Sign on Riverside Drive

sign, which is shown in the accompanying illustration. This sign is designed in several colors, and, as may be seen by the illustration herewith, is well calculated to attract the attention of passersby.

AMERICAN

In the AMERICAN line there is a model for every prospective buyer, seven sizes in mahogany, and five made in oak. The AMERICAN remain sold when delivered. Become an exclusive dealer in your town and your business will be a growing asset to you.

Standard and proven equipment throughout. Unsurpassed in tone qualities and artistic design and built by men who are artists in their respective lines. The AMERICAN is not an experiment and is fully guaranteed.

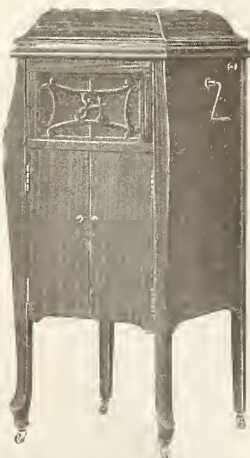

No. 8



No. 9



No. 10

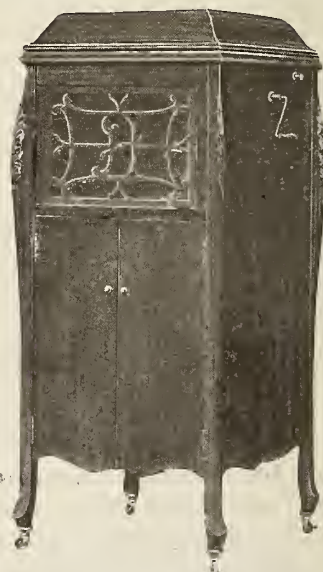

No. 11

Catalog upon request.

AMERICAN PHONOGRAPH CO.

39 FOUNTAIN ST.

GRAND RAPIDS, MICH.

NEEDLES

Manufactured by the

DEAN DIVISION

of the

OTTO HEINEMAN PHONOGRAPH SUPPLY CO.

INCORPORATED

25 WEST 45th STREET, NEW YORK

FACTORIES: Elyria, Ohio	Newark, N. J.	Putnam, Conn.	Springfield, Mass.
BRANCH OFFICES:	Chicago, Ill.	Seattle, Wash.	Toronto, Ont.

STEEL NEEDLES

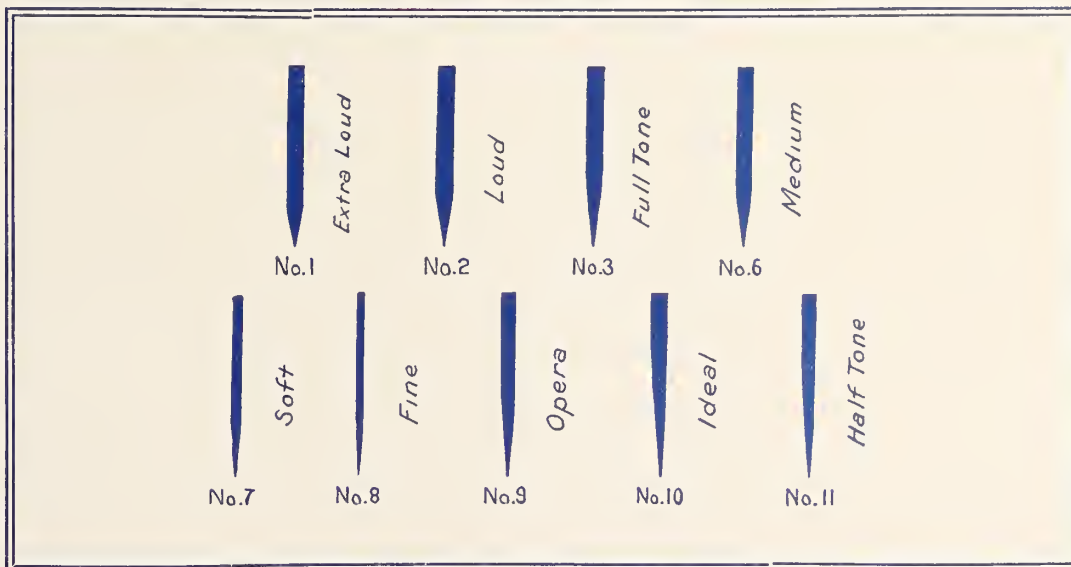

PERMANENT NEEDLES

TO PLAY PATHÉ RECORDS

Half Tone Points

Full Tone Points

TO PLAY EDISON RECORDS

Sapphire Points

Genuine Diamond Points





J. W. DESBECKER WITH SONORA CO.

Will Have Charge of Company's Advertising Service and Publicity

John W. Desbecker, formerly connected with the Redfield Advertising Agency, New York, is now associated with the Sonora Phonograph Sales Co., Inc., New York, and will have charge of the advertising service and publicity of this company.

After graduating from Cornell University in 1906, Mr. Desbecker was for six years in the sales departments of several large manufacturing corporations, and later entered the advertising field in the copy departments of several large New York advertising agencies. While connected with Frank Presbrey and the New York City Car Advertising Co. Mr. Desbecker had extensive experience in the handling of plan and copy for many important and successful firms.

For the past three years he has been asso-



John W. Desbecker

ciated with the Redfield Advertising Agency, and during that time has been responsible for the writing and preparation of all Sonora copy which has appeared. This copy has won commendation from the phonograph trade and advertising experts.

The Sonora Co., by securing Mr. Desbecker's entire time, will be in a position to give their dealers the benefit of the services of an experienced advertising man, as he has not only been active in the general advertising and merchandising fields, but has specialized and concentrated on musical lines as well.

Mr. Desbecker will work in close co-operation with Frank J. Coupe, advertising and sales director of the Sonora Phonograph Sales Co. The latter, who was recently elected a director of this company, is devoting the greater part of this time to the sales end of the business, and will act in an advisory and directing capacity in the advertising and publicity departments.

PENNSYLVANIA DEALERS MEET

SCRANTON, PA., November 30.—The Edison dealers in northeastern Pennsylvania held their first convention at the Hotel Casey, this city, last week for the purpose of discussing the general trade situation and plans for future development. Representatives from the factory of Thomas A. Edison, Inc., in Orange, were present at the convention, and addressed the dealers, who plan to hold their meetings during the coming year.

SELLING FORCE ENLARGED

Manager Tincher, of the talking machine department of the Scott & Hart store, Terre Haute, Ind., has added Mr. Galmoris, formerly of the Dennis Music Co., and Mr. Barnhart, formerly connected with the Chicago music trade, to his corps of assistants, thus preparing for increased activities.

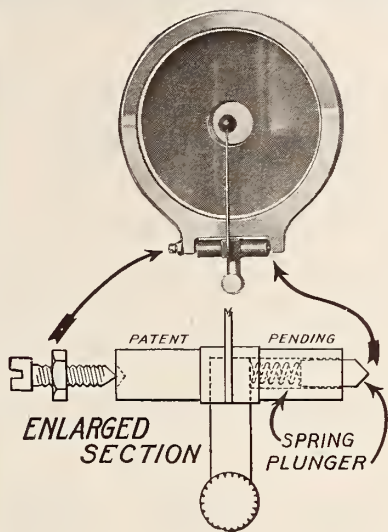

The New "Thin Model"

Fulton Reproducer

Considered by all who have heard it superior in **TONE VOLUME** and **"QUALITY"** to any heretofore produced.

Its use makes the ordinary phonograph a 25 per cent to 100 per cent better machine.

The simplicity of construction and adjustment precludes any annoying and expensive "comebacks."

Manufacturers are invited to send for sample on selection (when requesting sample specify tone-arm used).

Testimonials (unsolicited): One Manufacturer says: "It's Wonderful"; another: "Your reproducer beats them all"; another: "I shall use it on all models," etc.

This Cut illustrates the

Fulton

balanced cover lift.

Note Construction—

B—adjustable screw for any weight cover.

C—position of lift when cover is closed—giving a reverse "pull," counteracting the common tendency of all other lifts to warp cover.

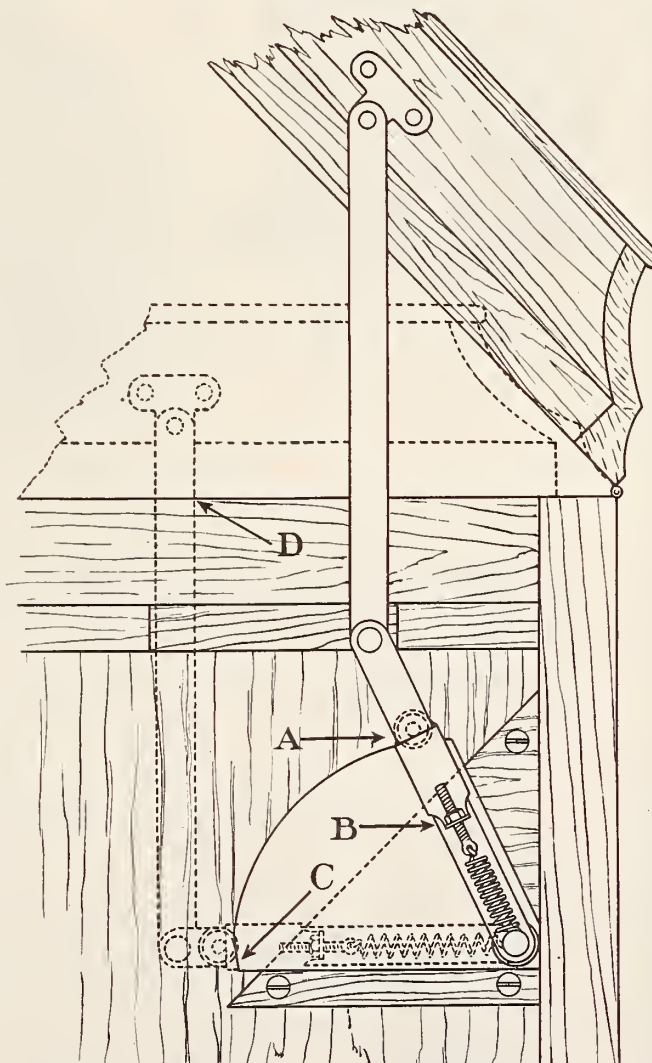

Sample gladly sent upon request.

FULTON-ALDEN CO.

Factory and General Offices, WAUKEGAN, ILL.

CHICAGO Warerooms and Offices,

Rooms 308-309, No. 20 E. JACKSON BOULEVARD



1919



Will Be A Profitable
Year for You If You Will
Handle and Push

The Product Of This Factory

WHERE
QUALITY
REIGNS
SUPREME

*The Home of the
"World"*



*Jobbers Are Invited to
Come and See*

HOW
WORLD
Phonographs
ARE MADE

The 1919 line of **World Phonographs** will surpass even the perfection of the present year's product.

We announce for 1919 *our own* **Motors and Tone Arms**

as well as *our own* **"WORLD" Line of Records**

Write for Details



WORLD PHONOGRAPH CO.

736 Tilden Street

Chicago, Ill.



ST. LOUIS TRADE PLAN AGGRESSIVE SELLING CAMPAIGNS

With the Opening of the Year and the Receipt of Needed Stocks of Machines and Records the Trade Intend to Bring Their Products to Public Attention in an Impressive Way—News of Month

St. Louis, Mo., December 6.—Talking machine dealers here are beginning to plan for aggressive selling campaigns. The plans are being laid for the future, the more optimistic dealers talking of February 1 and some of later dates, by which time they believe there will be a supply of machines obtainable that will justify aggressive merchandising. Most of these plans are somewhat different from the former systems, but, naturally, those who are making them are not yet willing to discuss new features because it is so long before they can be put to a test.

The Christmas business already has set in here and is going nicely. In fact, it started some time ago because a great many people have heard of friends who had trouble getting the kind of a machine they wanted. Not a dealer was found who believed that he had enough stock to meet all demands of his trade on all models. Jobbers are almost in despair. Some of them say they have very good customers who have not placed an order since early September, because that order is not all filled as yet.

There is much less talk of a record shortage than of the machine. Most dealers believe they are going to meet demands made on them in this line and this is based on the lively record trade that already has begun. A good many purchasers are taking liberal amounts of records and are having them wrapped and put aside until nearer the holidays.

The maximum of terms offered in present advertising is fourteen months, even in combinations of machines and records, and the dealers say that much less than half of their sales are on the long terms. One dealer was holding some models at cash.

A feature of the opening of the holiday season has been the new advertisers of talking machines. Furniture houses that have handled talking machines for years but have never pushed them have been using liberal space in promoting this trade. Some of the machines so advertised are not at all well known locally.

The Barthel & Dusenber Music Co. (Concordia Music House), on Pine street, just south of Piano Row, has recently been the most liberal advertiser of Edison Disc phonographs. This firm had not recently figured in newspaper publicity, but recently the lease on the present quarters were renewed and the advertising began to be a feature of the newspapers, being more liberally spaced than any other talking machine advertising for the period. With the first of December, a number of the old-line firms again came into line. Aeolian Hall enlarged

the space recently used in featuring of the Vocalion. The Silverstone Music Co., too, returned to the advertising lists with liberal space.

Manager Roose of the Columbia Co. spent a part of late November in New York, having gone to the home office to be present at any conferences that might take place on enlarged distribution. When he returned he said that while he looked for an increased flow of machines in the near future he thought the chief Christmas trade problem would be that of distribution.

The Artophone Co. warerooms have been completely redecorated and the work was done in advance of the beginning of the early Christmas trade. President Robert Cone says the beginning of this trade has been excellent and the terms obtained in the retail store are excellent. But more encouraging than this even are the prospects of getting cabinets in larger numbers.

"Following the release of the cabinet shops from war work the owners are seeking to take on our old contracts for talking machine cabinets and some of them already are busy on this work, but of course we will not begin to get their output until after the first of the year," said Mr. Cone. "The Christmas stock will be limited to the cabinet already made. But after January 1 we expect to resume taking large jobbing orders, which we could not handle for several months past. We are in excellent shape as regards motors and other important parts and once we get the cabinets coming through again we anticipate no trouble in handling the orders."

The Mozart talking machine, one of the oldest machines made in this city, has been taken over by the American Fixture and Showcase Mfg. Co., following the failure of the Colonial Cabinet Co. The American Co. has been advertising the machine and has been selling some at retail, but chiefly the effort has been to fill the jobbing orders. At the office of the American Co. it is said that the company has not yet made definite plans for the future, but after January 1 a plan of action will be decided upon. It was intimated that the manufacture of the machine would be continued in large quantities. The American Fixture & Showcase Co. is a substantial and well-organized concern that has not heretofore been identified with the talking machine business, although it has been making some cabinets.

Another influenza ban which extends to all business meetings has postponed the annual meeting of the Tri-State Victor Dealers' Association until after the first of the year. There is no prospect that the health department will permit meetings in this city until after the holidays now and, besides, there was an inclination on the part of the directors of the association to postpone the meeting until after the busy season. It was felt that owing to stocks, etc., each dealer would feel that he could hardly be spared while the Christmas sale is on.

The business hours of most talking machine stores now are from 9.30 a. m. to 6 p. m., these hours having been fixed by the Retailers' Association to meet the requirements of the influenza situation and to aid in the local traffic situation. This brings store clerks down later than other workers and keeps shoppers off the cars during the rush hours.

ENLARGE EDISON DEPARTMENT

The C. F. Murray-Smith Co., Edison dealers in Wilkes-Barre, Pa., have found business increasing to such an extent that it has been necessary for them to increase materially the space devoted to that department. The additional space will be devoted to the Edison Disc phonograph line, while some of the space formerly devoted to the disc department will be utilized for the handling of Amberola records.

1919—

A Big Year for the Talking Machine Trade

Make your plans now but be sure your cabinets are right



Harponola

Our Cabinets are exceptional in

Appearance
Individuality
Finish
Strength

built by a furniture house of long standing.

Whether you are a dealer, manufacturer or jobber send Now for our proposition for you.

Our Cabinets will help make the new year a prosperous one for you.

We will be glad to send you all information

CELINA FURNITURE CO.
CELINA OHIO

The VIVITONE

Gives New Richness of Tone to Your Favorite Records

This Tone Controller is the 1919 wonder of the Talking Machine World.

Insert Vivitone in the needle post of the sound box. You will be delighted with the vivid, pure, vibrant tone that results.

Shut your eyes and you imagine you are hearing the living voice of the singer or the actual music of the instrument.

The Vivitone can be used with all phonographs that use either ordinary steel or Tungsten needles.

Each package contains four tubes, playing thousands of records. Retail for 50 cents per package.

Sample free to Dealers who write for proposition on their letter head.

Vivitone Controller Company

400, 401, 402 Bell Block, Cincinnati, O.

*Built by men who have
made a life study of tone
production*



*The
Bush
and
Lane*

*A Perfect Musical
Instrument*

BUSH & LANE PIANO CO.
Manufacturers
HOLLAND, MICH.

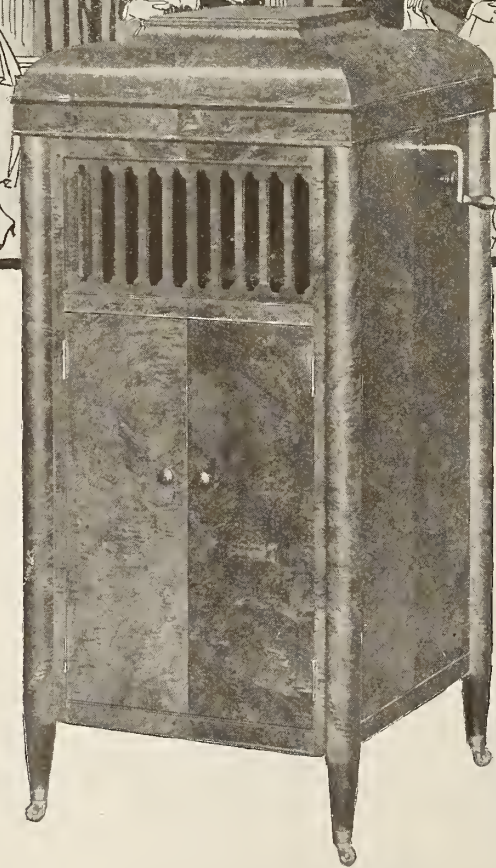

TWO NEW VOCALION ARTISTS

Nellie and Sarah Kouns Now Entertaining Soldiers in France to Make Records for the Aeolian-Vocalion Record Library

The Aeolian Co., New York, has announced the addition to its staff of artists recording for the Aeolian-Vocalion record library of Nellie and Sara Kouns, young American sopranos, who



The Kouns Sisters

have achieved signal success on the concert, musical comedy and vaudeville stages. These two artists will record for the Aeolian-Vocalion library exclusively, and their first recordings will be announced very shortly.

The Kouns Sisters, as they are popularly known in musical circles, are the daughters of C. W. Kouns, of Topeka, Kans., for many years general manager of the Santa Fe Railroad. Their voices are identical as to quality and range, and this unusual combination has been responsible in a considerable measure for the unique position which they have created for themselves in musical circles.

The two girls received their musical education abroad and during their stay in Europe gave concerts before many of the most prominent musical patrons in the different European countries. They were received with enthusiasm everywhere, and their ability was recognized by an offer from the directors of the Munich Opera Co., who desired to "star" the young American sopranos. Mr. Kouns objected, however, to his daughters entering the operatic world and visited Europe to bring them home.

Arriving in America, the Misses Kouns overcame their father's objections to their appearing in public, and started on an extended concert tour through the Middle West—appearing as solists with the leading symphony orches-

tras in the United States, and duplicated in their native land their European successes. After their last annual recital held at the Playhouse, Chicago, they received offers from prominent managers in all parts of the country to appear in a varied assortment of musical productions, and decided finally to accept a lengthy vaudeville engagement. During this engagement they appeared as "headliners" at the leading theatres on the "big time" circuit and also appeared in several well known musical comedy successes.

At the present time the Kouns Sisters are singing for the boys in France, having left for the other side of the Atlantic last month, in order to entertain the boys in the trenches.

ATTRACTIVE WINDOW DISPLAY

The Columbia Window for January Specializes on One Artist

There is shown herewith the centerpiece of the Columbia Co.'s monthly window display service for January, which follows a new plan on the part of the company to feature special artists each month and thereby furnish its dealers with window material of a more permanent nature which may be used in connection with the artists' appearance in the various towns throughout the country.

Much of this brilliantly lithographed window display material can be used to excellent advantage as interior store decoration, and it is with this thought that every month a number of the units are designed to be of a permanent nature. Many of the smaller cards can also be used effectively as booth decorations and cut-out record holders placed on counters and over shelves about the shop will also stimulate record sales. Each display has a direct tie up with current Columbia advertising of that particular month. Newspaper ads, magazine copy, supplements and bulletin hangers all bearing a similar illustration and copy are reproduced on the displays and in the dealers' window service,



Centerpiece Columbia Window for January thereby serving to concentrate an interest in the store and on the part of the buying public in that market place of the Grafonola.

The Lampograph

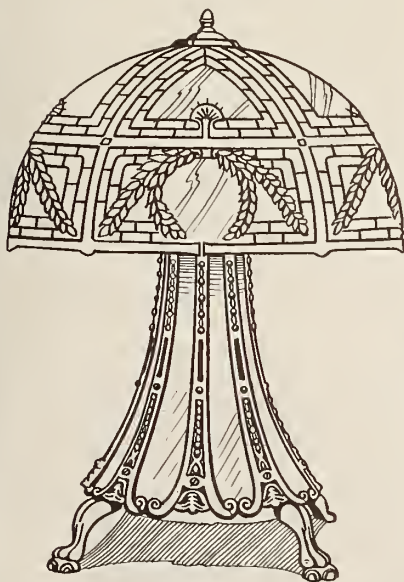

PATENTED

The greatest invention in the phonograph industry during the last twenty years.

To turn a piece of clumsy furniture into an article of virtue has been the dream of many bright minds. This is now realized. Although it is still a phonograph it is now also a fine decorative feature in the home.

Thousands of people will like to have a high price phonograph but they have not the space for a bulky cabinet. Thousands of dealers are in the same fix.

The LAMPOGRAPH will save all these troubles and they will be handled by the best dealers and most exclusive jewelers as well. When furnished in gold and

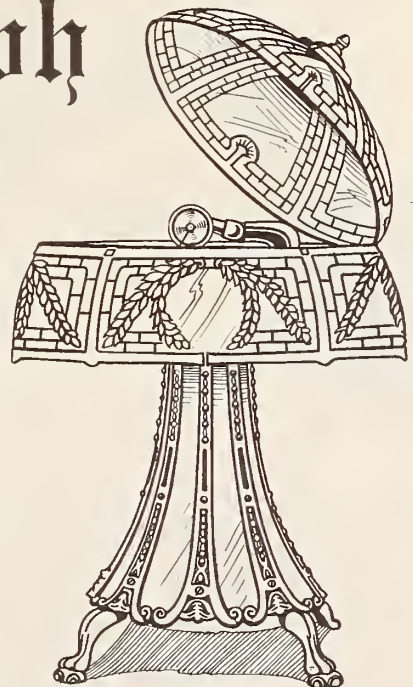

PATENTED

silver set with rubies, sapphires and other fine jewels they will make most magnificent gifts and many will discard their old machines in order to secure this new jewel. It does not take much space and will facilitate express services, thus enabling factories to make better deliveries. Other big features to be announced later.

Applications from first class dealers will be considered in order received, also applications from first class manufacturers as well and business men of constructive ability

FRANK H. FERAUD, 1911 State Street, Granite City, Ill.



Never was such a time for selling Grafonolas and Records. Are you getting your share of the business?

Columbia Graphophone Co.
NEW YORK

FEDERAL COMMISSION STUDYING PRICE FIXING PROBLEM

Special Report Made by the Federal Trade Commission Recommends Legislation Which Will Tend to Protect the Manufacturer, and Yet Prevent Unfair Prices to the General Public

WASHINGTON, D. C., December 3.—“It would be unwise to vest with the manufacturers of articles the right, without check or review, both to fix and to compel the maintenance of resale prices,” the Federal Trade Commission declared in a special report to Congress on the question of whether or not a manufacturer of standard articles, in interstate commerce, identified either by trade-mark or trade practice, should be permitted to fix by contract, express or implied, the price at which the purchaser can resell them.

“It is true,” the Commission continued, “that business practice inclines producers to fix the lowest possible retail price in order to secure the greatest possible sale of their product, but in the complex commercial organism functioning between the production of an article and its final sale, for actual consumption, both the

wholesale and retail merchants are entitled to just compensation for useful service performed.

“The question has been continuously before the Commission since its creation. It has been the subject of study, investigation and hearing and constantly recurs in various form in complaints filed with it by business concerns.

“The Supreme Court has made it clear, it was said, that, in the present state of the law, the maintenance of a resale price by the producer is a restraint of trade and is unlawful.

“Such being the judgment of the Supreme Court, the Federal Trade Commission has enforced the law, even though it may have appeared to operate inequitably in some cases. In its enforcement of this rule the Commission has been mindful that the cutting of a recognized resale price on well-established and iden-

tified articles has been, at times, indulged in for unfair trade purposes. When so unfairly used such price cutting is attempted to be cloaked as lawful competition and justified by the Supreme Court decisions.

“Thus, both price maintenance and price cutting under certain conditions are found to be unfair and business men are perplexed. It is with the desire that this perplexity may be terminated that the Commission addresses the Congress.

“It is similarly urged that manufacturers should be protected in their good will created by years of fair dealing and of sustained quality of merchandise.

“The consuming public does not enjoy benefits by unfair price cutting to compensate it for the injuries following demoralization caused by price cutting. This for the reason that, in the long run, unrestrained price cutting tends to impair, if not to destroy, the production and distribution of articles desirable to the public.

“There must be a common ground wherein the rights of producer, purveyor and consumer may each be fully secured and equity done to all. The search for such a ground has been a task of the Commission and results in the following conclusions:

“That producers of identified goods should be protected in their intangible property right or good will.

“That the unlimited power both to fix and to enforce and maintain a resale price may not be made lawful with safety.

“That unrestricted price cutting is not in the public interest.

“Bills now pending before Congress may well be made to meet the difficulties of the situation if amended to provide for a review of the terms of resale contracts and a revision of resale prices by a disinterested agency.

“Therefore, it is recommended that it be provided by law that if the manufacturer of an article produced and sold under competitive conditions desires to fix and maintain resale prices, he shall file with an agency designated by the Congress a description of such article, the contract of sale and the price schedule which he proposes to maintain and that the agency designated by the Congress be charged with the duty, either upon its own initiative or upon complaint of any dealer or consumer or other party in interest, to review the terms of such contract and to revise such prices and that any data and information needful for determination be made available to such agency.

“Such legislation would seem to be in accordance with the spirit of the times in that it is designed, by removing this perplexity, to promote the efficiency of manufacturing and commercial institutions and so serve the interest of the consuming public.”

J. R. Smith, the well-known salesman in other lines of trade, has joined the staff of the talking machine department of the Stewart Dry-goods Co., Louisville, Ky.

The Parr Central Universal Tone Arm



(Patent Applied for)

IMPORTANT and EXCLUSIVE Features of the Parr Central Universal Tone Arm

Height Adjustment

The clearance of reproducer over record is obtained by turning and locking the small screw under large elbow. This clearance should be about 1/16 inch when reproducer is in the inoperative position for playing the lateral cut type of record.

Automatic Change of Weight

In turning the reproducer so as to play the vertical type of record, the weight of reproducer on record is automatically increased, sufficiently to give greater weight for properly playing such records. This is a very novel and important improvement in tone arm construction and should appeal to those who have wanted a tone arm that would not require the makeshift arrangements for doing what this tone arm does automatically when it is desired to play hill-and-dale records. In playing the lateral-cut record, the weight on record is that of reproducer only.

Durability

All parts have been properly designed with the view of compensating all wear. There is no possibility of the development of loose joints or connections as all such wear is automatically taken up.

Other Important Features

The Parr Tone Arm is adjustable to any length required. The design of the tone arm permits perfect playing of either type of record without additional attachments. The needle always rests in the same point, setting in the direct center in playing either position. The sound box can be turned, allowing the needle to be changed with ease, and by a reverse movement the box returns to its normal playing position. The Parr Central Universal Tone Arm and Magnetic Reproducer form a combination which makes for superior reproductions, attractiveness and utility.

PARR MANUFACTURING CORP.
ONE UNION SQUARE - - - NEW YORK



Featuring the Musical Possibilities of the Talking Machine

By William Braid White

[Note.—This is the twenty-second in a series of articles on the general subject of the musical possibilities of the talking machine. The aim of the series is to develop these possibilities from all angles, thus opening up fields for sales expansion oftentimes neglected wholly or in part.—Editor.]

DIVAGATION—NEW PATHS

It was under this title that Schumann opened that revolutionary musical essay in the pages of his own periodical, which first heralded to music-loving Europe the coming of young Brahms. Without hesitation I speak here of these two great musicians, maugher their birth in the land of the modern Hun, for neither of them had the faintest idea of the extraordinary and hideous materialism which has been the gospel, and the ruin, of Germany. They belonged to another era, to the days of a Germany of which it was once said that, while England had conquered the sea and France the land, she had conquered the clouds. Germany since 1870 is not the Germany whose music we shall want to hear during coming years, Wagner indeed wrote his greatest work before 1870 and was once no lover of Prussia or Prussianism, having been a red revolutionary, hunted by the police in 1848. Yet, even Wagner could be guilty of the cheap vulgarity of "Fine Kapitulation," a disgusting and typically Prussian sneer at France after the surrender of Paris in 1870; not to mention that he was memorized into the writing of the very bombastic and empty Kaiser, in glorification of the first Emperor William, of which, amusingly enough, the old man, whose musical ideas were as rudimentary as those of all Prussians, took not the slightest notice. We shall have to do without Wagner for some time to come, if not permanently. And why not? Certainly we shall have to do without the banalities, the brutalities and the mechanicalities of Richard Strauss, Max Reger, Georg Schumann and others of the modern Kultur tribe. It is strange, is it not, how the poison of modern pan-Germanism has forced its way through the veins of every limb of German life. When the ninety-three German intellectuals signed their amazing circular letter, gravely asserting, and no doubt thoroughly believing, that the highly superior and moral German soldiers simply had not been guilty of burning down the fair city of Louvain (or at least, had gone about their "necessary" work of destruction with tears streaming down their cheeks) they revealed with blinding clearness the extent to which the German intellectual mentality can, upon occasion, be mesmerized. Among these ninety-three names were those of Richard Strauss and Felix Weingartner, then newly ennobled and made a "von" by the (once called) All-Highest. Somehow we feel we can get along without the modern German music for awhile.

Getting Back

But this is a digression, and rather a long one at that. I began to talk about new paths, meaning the new notions the talking machine men will have to imbibe and digest for the better prosecution of their business, and the new directions they will have to take, now that the war is over. The temptation to "strafe" the Hun a bit was, however, too timely and far too fascinating to be thrown overboard, and I confess I went to it with much joy. But it is time we should return to our muttons.

In these articles I have frequently pointed out, and still more frequently implied, that the talking machine, or phonograph, as a musical instrument pure and simple, is still in its infancy, and as yet has realized scarcely any of the manifold possibilities inherent in it. It would be wrong to suppose that even the most completely accepted features in the modern machine are settled to remain as they are forever: The fact is that the musical possibilities of the talking machine are just beginning to be appre-

ciated to-day, and that in consequence a much more critical attitude towards tone production and the presence of mechanical or musical imperfections is being adopted by everybody. When I say everybody I mean that public which buys our goods, those ultimate consumers whom we have finally to please; these quite as much as ourselves of the trade. Yes, the truth of the matter is that we are growing gradually more critical. What other explanation is to be found for the constant emergence of new and improved tone arms, sound boxes and other accessories intended to refine reproduction and eliminate scratch? How otherwise are we to explain the experimental work recently brought to a climax by the Eathé people? We are becoming more critical, and a very good thing, too.

The Musical Side

Now, if this be true, as it certainly is, then by all means is it true that the retailing of the talking machine is bound to become more and more a matter of emphasizing the purely musical side of the business. It is just here our educational work is needed, both among the trade and with the people. It is just here we shall make or mar our future.

The talking machine has made its success solely because it has brought the purchaser into indirect but acute contact with all kinds of music as rendered by all sorts of musicians. In spite of a thousand and one minor defects in recording and reproduction, the underlying and determining fact is that the singing, playing or speech of a certain specific known artist is being represented. This it is which has made the talking machine the wonderful success it is. It is here we find the really logical and direct path towards the further logical development of the talking machine. Here we must devote our efforts to refining methods of bringing the artist and the home into mutual contact. That is the big secret: to bring the personal musician into the home.

Demonstration

But whilst we are trying to do this we must also remember that the talking machine is an instrument of fair cost, and one which is not bought as one would buy a paper of pins. It has to be "sold," and in these days with many

conflicting claims of many makers it is not always the easiest thing in the world to show the prospect that one really has the goods. It is just here the principle above enunciated comes into play most effectively. So much depends upon the demonstration made to the prospective purchaser that the best machine made will not stand a chance with one actually inferior if the second be demonstrated in such a way as actually to put before the prospect acutely and persistently the idea that the same music in his or her own home will sound just as beautiful as it does during the demonstration.

Moreover, with so many different machines to choose from what is the use in bothering the prospect with technical claims? It would not be unjust to say that the greater part of all the technical talk is wasted. The physical basis of sound is too vague and misty a matter to the majority for any salesman to expect to make it clear. And if he cannot do this what is the use of his trying to sell on talking points?

The Home Contact

The big selling argument for the talking machine must be the bringing of the home into contact with the musical artist or entertainer. When you have got a prospect to realize that he can hear Galli-Curci, Lashanska, Caruso, McCormack or Anna Case sing at home you have him started on the right path. If he buys then he will only be doing the expected. And if he ever loses his interest in new records this will be because you did not make a selection for him in the days when he was unable to choose for himself intelligently, or for some similar reason.

The whole art of selling a talking machine is comprised in finding out the prospect's taste in music or entertainment, seeing that the prospect hears the sort of thing he wants to hear in conditions as nearly as possible paralleling those of the home itself, and leading him on to realize that many more fields of musical pleasure and entertainment lie beyond him. If a talking machine is sold on the basis of letting the prospect buy it on the terms advertised because it is a talking machine, for which a vague desire has been created through advertising and

(Continued on page 74)

7th Floor

229 Fulton Street

Clifford A. Wolf

MANUFACTURER OF

Diamond and Sapphire
Phonograph Points

New York City

Phone, 1678 Cortlandt

Lundstrom CONVERTO

Patented December 11, 1917

TALKING MACHINE CABINETS

Designed to accommodate the
VICTROLAS "IV" and "VI"
have already demonstrated to thousands of
VICTOR DEALERS

a way in which they can dispose of their smaller type machines and do it quickly. THE COMBINED COST of the VICTROLA and "CONVERTO" CABINET affords the DEALER one of the strongest selling propositions in the Talking Machine line, at an opportune time, as there is a great demand for cabinet type machines. CAN YOU IMAGINE a prospective purchaser buying an unknown cabinet type machine, providing you can offer A GENUINE VICTROLA WITH ALL OF THE ADVANTAGES OF THE CABINET TYPE at a LOWER PRICE? By meeting competition in this manner there is one result. YOUR SALES INCREASE, and YOUR PROFITS DOUBLE on each combination sold.

By circularizing your "retired list of customers" in connection with your monthly record list you will find PRESENT OWNERS of the smaller VICTROLAS will readily appreciate the merits of the "CONVERTO" CABINET, which provides protection for Machine and Records from dust and incidentally adds a handsome piece of furniture to the home. "Converto" sales will result in increased Record sales.

JANUARY is a big month for the VICTOR DEALER. Why not prepare now by consulting with your WHOLESALER?

The C. J. Lundstrom Mfg. Co., Little Falls, N. Y.

LUNDSTROM "CONVERTO" CABINETS are broadly covered by patents. Infringements will be promptly prosecuted.

STRONG SELLING POINTS

Lundstrom "Converto" cabinets are made in OAK and MAHOGANY FINISHES and convert the smaller Victrolas into handsome cabinet types, without affecting the portability of the machines.

Protects machine and records from dust.

Provides receptacles for new and used needles.

Places a genuine VICTROLA with the cabinet type effect into the hands of the user at a price less than is usually charged for cabinet type machines of unknown make.



Setting Victrola into Cabinet

Sound Doors Open for Playing

Converto Wholesale Distributors

- Atlanta, Ga..... Phillips & Crew Piano Co.
- Austin, Tex..... The Talking Machine Co. of Texas
- Baltimore, Md..... Cohen & Hughes
- Birmingham, Ala..... E. F. Droop & Sons Co.
- Boston, Mass..... Talking Machine Co. Oliver Ditson Co.
- Brooklyn, N. Y..... The Eastern Talking Machine Co.
- Buffalo, N. Y..... American Phonograph Co.
- Cincinnati, O..... W. D. & C. N. Andrews.
- Cleveland, O..... The Perry B. Whitist Co.
- Colmhus, O..... Sanger Bros.
- Dallas, Tex..... The Knight-Campbell Music Co.
- Denver, Colo..... Elmira Arms Co.
- Elmira, N. Y..... W. G. Walz Co.
- El Paso, Tex..... J. W. Jenkins' Sons Music Co.
- Kansas City, Mo..... Schmeltzer Arms Co.
- Memphis, Tenn..... O. K. Houck Piano Co.

- Milwaukee, Wis..... Badger Talking Machine Co.
- Mohile, Ala..... Reynolds Music House.
- Newark, N. J..... Price Talking Machine Co.
- New York City, N. Y..... Emanuel Blout I. Davega, Jr., Inc. S. B. Davega Co. Mickel Bros. Co.
- Omaha, Neb..... Putnam-Page Co., Inc.
- Peoria, Ill..... The George D. Ornstein Co.
- Philadelphia, Pa..... Penn Phonograph Co., Inc. H. A. Weymann & Son, Inc. W. F. Frederick Piano Co. C. C. Mellor Co., Ltd. Standard Talking Machine Co.
- Pittsburgh, Pa..... Cressey & Allen, Inc.
- Portland, Me..... The Corley Co., Inc.
- Richmond, Va..... W. D. Moses & Co. W. J. Dyer & Bro. W. D. Andrews Co.
- St. Paul, Minn..... The Whitney & Currier Co.
- Syracuse, N. Y..... Cohen & Hughes
- Toledo, O..... E. F. Droop & Sons Co.
- Washington, D. C.....

DIVAGATION—NEW PATHS

(Continued from page 73)

through hearing the neighbor's machine, then you may be sure the sale will not be of the best type of machine, and that the purchaser will not be a good record buyer in later days. The whole basis of all intelligent selling must be this bringing music into direct contact with the home. You are not, in a word, selling machines, you are selling means for musical enjoyment in the home.

The "new paths" of which I spoke above are open before us. It is our business to tread them firmly. Their foundation is this recognition of the talking machine as a musical instrument and of music as the reality for which the prospect really searches and which alone the wise salesman will try to sell him. No prospect, be it remembered, ever started out with the idea of buying a "machine," but every prospect was thinking of "music." To sell talking machines we must sell "music at home," and not only that but "musicians with you at home." This is the new path and the true salesmanship. Wishing you one and all a Merry Christmas and a Happy New Year!

JOIN IN RUNNING VICTORY AD

Thirty Piano and Talking Machine Houses Co-operate in Publishing Announcement

The special Victory advertisement by C. M. Tremaine, drafted immediately after the announcement of the armistice, as a feature of the co-operative advertising campaign now being carried on by piano merchants in various sections of the country, was featured in the New York Times on Tuesday morning of this week, a number of prominent piano and talking machine houses co-operating in running the advertisement, and having their names underneath. Those houses listed in the advertisement were the Aeolian Co., the Autopiano Co., Behning Piano Co., Bogart Piano Co., Brambach Piano Co., Christman Sons, Chas. H. Ditson & Co., Jacob Doll & Sons, Estey Piano Co., Edison Shop, J. & C. Fischer, E. Gabler & Bro., Hallet & Davis Piano Co., Hardman, Peck & Co., William Knabe & Co., Kranich & Bach, Krakauer Bros., Mason & Hamlin Co., Mathushek Piano Co., Paul G. Mehlin & Sons, N. Y. Talking Machine Co., Pease Piano Co., John A. Schaff, Steinway & Sons, Story & Clark Piano Co., Wm. Tonk & Bro., Inc., Wessell, Nickel & Gross, Winterroth & Co., Otto Wissner, Inc., and the Rudolph Wurlitzer Co.

The advertisement occupied a full seven columns in the Times, and made a most impressive showing, being most timely in character.

HEINEMAN CO. AIDS WAR FUND

Contributes \$1,500 to United War Work Drive—Employees Do Good Work

As usual, the Otto Heineman Phonograph Supply Co. went "over the top" in the United War Work drive, which recently ended, and the company contributed to this fund \$1,500, which was credited equally to the New York, Newark and Putnam plants. Otto Heineman, president of the company, also made a large personal subscription, and many of the employees worked indefatigably in the interests of this loan in their home localities. This company has an admirable record in connection with the various war drives, as 100 per cent. flags for every Liberty Loan and Red Cross drive have been awarded to the Otto Heineman Co.

TALKER DEPARTMENT MOVED

Robert H. Barwid & Co., 3008 Lincoln avenue, Chicago, has rearranged his store and moved the Victrola department to the first floor in order to take proper care of the growing trade.

Sanders & Stayman, Baltimore, Md., are experiencing quite a demand for the period designs of Aeolian-Vocalion.



Otto Heineman Phonograph Supply Co.

INCORPORATED

25 WEST 45th STREET, NEW YORK

FACTORIES, ELYRIA, O.—NEWARK, N. J.—PUTNAM, CONN.

CHICAGO

ATLANTA

SEATTLE

CINCINNATI

TORONTO



OKEH RECORDS

Music on both sides.
Sapphire or steel needle.
Popular and standard selections.

Full particulars regarding the distribution of this record will be given to any dealer or jobber upon application.



This label guarantees quality

We guarantee service. Quality and service guarantee success.

You get prompt delivery of
Latest Broadway Hits

on

O K E H RECORDS

10-Inch Double Disc

JOBBER
DEALERS

OKEH RECORDS are of special interest to you.

A remarkable proposition.

Get in touch with us today.

Have you heard an OKEH Record?

OTTO HEINEMAN PHONOGRAPH SUPPLY CO., Inc.
25 West 45th Street, New York.
Gentlemen:-

I am interested in your OKEH RECORDS
Please put me on your mailing list.

Name.....
DEALER OR JOBBER

Street.....

City..... State.....

LET YOUR EAR BE YOUR JUDGE

Foreign Language Records sell splendidly around Christmas. Why not lay in a stock? For particulars, write

**INTERNATIONAL RECORD DEPT.
102 West 38th St., New York**

**Columbia Graphophone Co.
NEW YORK**



DECIDEDLY BETTER CONDITIONS EXIST IN SAN FRANCISCO

Talking Machine Dealers' Association Elect Officers—Conditions With Sherman, Clay & Co.—New Brunswick Dealers—Columbia Renovations—Hauschildt Expansion—New Columbia Representation

SAN FRANCISCO, CAL., December 4.—The trade in San Francisco is experiencing decidedly better conditions this month than it has for some time. The signing of the armistice was the occasion for general rejoicing, and the influenza has practically disappeared. Lack of machines has been a handicap to the dealers, who can sell all available machines easily. The holiday trade started early and many stores have found it necessary to make additions in their departments to take care of the business. Record sales are brisk, and the dealers are fortunate to be able to fill the standing orders.

The offices and salesrooms of the Columbia Graphophone Co. have been entirely done over. The stockrooms have been enlarged, and the offices redecorated. Nathan F. Milnor, the Pacific Coast manager, says the only things the salesrooms need now are a few more machines. He received word from the factory that a reinstatement of prices will be arranged immediately, and with deliveries more frequent the future looks very bright for this company. H. Warren Coster, formerly of New York, has been made the Columbia representative in the bay cities. Frank Dorian visited the San Francisco office on his way to Seattle, Wash., where he will assume charge of the company's branch in that city. While here Mr. Dorian and his family were the guests of Nathan F. Milnor.

An attractive display of Pathé machines is the feature of the new phonograph department of Kohler & Chase in San Francisco. At present this is the only line the house carries. In their branch store at Vallejo, Cal., opened since the 15th of the month, the Pathé has received favorable recognition.

A meeting of the Talking Machine Dealers' Association was held in San Francisco on the 26th of the month. The following officers were elected: F. A. Levy, of the California Phonograph Co., president; F. L. Valentine, manager of the Hauschildt Music Co., vice-president; A. A. White, of the White Music Co., in Berkeley, and W. F. Morton and Bent Scott will take charge of the entertainment committee. This was the first meeting since February, and the members of the association are looking forward with pleasure to the resuming of the regular monthly gatherings.

Business in the Victrola department of Sherman, Clay & Co. has been materially affected by the lack of machines. All available stock has been sold, and the department is waiting for a change for the better in the matter of shipments from the factory now that the Government restrictions have been lifted. The record department is reported as being in fairly good shape, and lately several shipments have reached the Coast. The sales are good in this line, especially since the beginning of the holiday season. Andrew G. McCarthy, manager of the talking machine department, is very optimistic over con-

ditions for the next year, and is making preparations for the long-desired shipments of machines. Captain William Mallatrat, son of Commodore Mallatrat, connected with the wholesale department of the Victrola, cabled his father news of his recent promotion to the rank of major. After a year with the Canadian Aviation Forces, Archibald Orr is back in the Victor department of this firm filling his old position.

The Hauschildt Music Co. has been giving special attention to its phonograph department recently, with exceedingly gratifying results. F. L. Valentine, manager of the local store, has been busy with improvements and additions, which were ready in time for the Christmas trade. Two stockrooms have been added, with extra space for records, and on the second floor one side is fitted up with sample models of the different phonographs on display. All the latest record shipments are arriving by express, to insure prompt delivery for the holidays.

Clark Wise, of the Clark Wise Music Co., is elated over the size of his Victrola stock. He has been on the lookout for machines for several months past, in anticipation of the shortage experienced here on the Coast. In consequence, he expects to have enough machines to carry the department over the season.

F. A. Smith, manager of the San Francisco offices of the Brunswick-Balke-Collender Co., reports the success of a new Brunswick model known as No. 35. This company has recently arranged an agency with the Palace Drug Co., with stores in Monterey, Pacific Grove, and Carmel, Cal., where the Brunswick is fast becoming popular. A. B. Wilson, a prominent dealer in Martinez, Cal., has also added the Brunswick to his stock.

The Century Music Co., which handles talking machines, has moved from Stockton street to larger quarters on Market street.

Walter S. Gray, the "Needle King," has a fine stock of Brilliantone needles and other specialties on hand, and is so situated that he can fill all orders promptly.

F. B. Travers, manager of the Sonora Phonograph Co., is back in San Francisco after a successful trip in the Northwest.

The Pfeifer Music Co., of Stockton, have added a complete line of Columbia graphophones to their stock.

The trade in San Francisco mourns the death of H. J. Curtaz, for many years connected with the music business in this city. He died early last month, leaving a son and daughter, as well as sisters and brothers.

Omer N. Kruschke, of the Western Phonograph Co., has taken up his usual travels after the abatement of the epidemic. His firm is the distributor for the Pathé machines and records in California, Nevada and Arizona. He looks forward to booking some big orders.

THE VANOPHONE

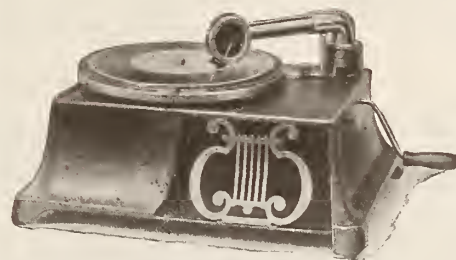

VANOPHONE MODEL C
Manufactured by a company of country-wide prestige.

The Leader in Its Field

RETAILS AT

\$15

and is guaranteed to give absolute satisfaction

The VANOPHONE Model "C" plays all records on the market. It is constructed of the best materials that can be secured and is a ready seller

Arrange Today for a 1919 Vanophone Agency

WE ARE GENERAL DISTRIBUTORS FOR THE OKEH RECORD
A SPLENDID 10" DOUBLE FACE HILL AND DALE RECORD

THE GARFORD MFG. CO., Dept. B, ELYRIA, OHIO

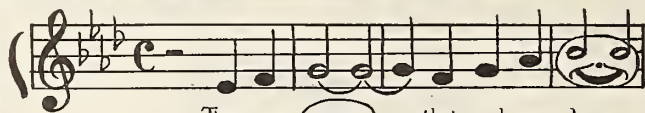

There are ☺ that make us happy,

WHY NOT! WAR'S OVER
Christmas coming — Business
going to be better than ever.
Chicago Talking Machine Co.

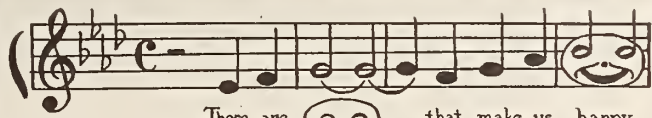

There are ☺ that make us happy,

WHY NOT! WAR'S OVER
Christmas coming — Business
going to be better than ever.
New York Talking Machine Co.

MILWAUKEE SEES NEW ERA WITH END OF WAR

New Life in Business—Stock Shortage Troubles
—Views of H. A. Goldsmith—New Sonora
Dealers—Co-operative Advertising Wins Out
—Association Grows—News of Interest

MILWAUKEE, Wis., December 11.—There now seems to be not the slightest obstacle remaining in the way of Milwaukee and Wisconsin talking machine dealers to make their holiday business this year the best in volume and turnover of goods of any Christmas season they have ever experienced. The shortage of merchandise, a bugaboo that has existed for several months, is being overcome by various ways and means. While it still is an imposing deterrent, dealers in the main feel certain that they will be able to fill requirements fairly well and in this manner will enable them to pile up a record-breaking volume, even disregarding the extent to which increased prices, compared with a year ago, enhance the volume.

The end of the war a month ago seemed to put new life into both dealers and customers. As irksome restrictions were revoked by governmental agencies, which imposed them upon retail merchants to meet the needs of wartime conditions, trade accelerated until at this time it is probably more active than it ever has been. The appeal to the public to shop early has been answered to a satisfactory degree. Early December trade this year showed such appreciable increases over the same period of 1917 that dealers feel they have made much headway in extending the holiday shopping period from the last few days before Christmas to the first of December, and even the middle of November.

If more merchandise were available before Christmas, doubtless a much more pleasing increase in business could be shown, as the demand is such that stocks on the floors of retailers on January 1, 1919, will be by far the smallest of all time. Although talking machine industries that of necessity were converted to a greater or lesser extent to the urgent direct necessities of war are rapidly increasing their outputs toward the pre-war goal, production will hardly be brought to a level with trade demands for several months to come, is the opinion of local jobbers and retailers as well.

"Conditions in respect to stocks were very unfavorable prior to the time of the collapse of



PERSONAL SERVICE

The members of our Company are always available and will gladly see you personally or write you at any time we can possibly serve you.

Why not communicate at once with us?

BADGER TALKING-MACHINE CO. 135 Second Street
MILWAUKEE, WIS.
VICTOR DISTRIBUTORS

the German war machine and its unconditional surrender, but since then demands from our dealers have increased so largely that it has become a matter of fight, fight, fight, for goods," said Harry A. Goldsmith, secretary of the Badger Talking Machine Co., Victor jobber, 135 Second street, Milwaukee. "Our floors are practically bare of merchandise, for as soon as we are able to obtain fresh goods the dealers are at our doors clamoring for them. This is not due so much to the general shortage of goods as the enormous demand for talking machines"

The Yahr & Lange Drug Co., of this city, distributor of the Sonora in Wisconsin and Upper Michigan, is establishing the record of marketing approximately seventeen carloads of these goods during 1918. In a little more than ten months' time the company received fourteen carloads, containing something more than 2,200 machines. At the beginning of December three more cars were in transit to Milwaukee, and the entire shipment had been spoken for by dealers before the goods left the factory. The Yahr & Lange Co. now has twelve dealers in the city of Milwaukee, and four dealers in the county. Recent additions to the city list include the Kunzelmann-Esser Co., 460 Mitchell street; Winter Piano Co., 375 Grove street; Noll Piano Co., 460 Muskego avenue, and A. Kittelmann, 1819 Center street. The recent decision of the Federal Court at Chicago against infringers of the Sonora name and trade-mark has been given wide publicity by the Yahr & Lange Co.

A development in the local retail trade of the past few weeks that is notable is the appointment of the Kesselman-O'Driscoll Co., 258 West Water street, as retail distributor of the Edison in the downtown district of Milwaukee. The Kesselman-O'Driscoll Co. up to this time has been an exclusive Victor dealer, and will continue to represent this line. For the time being at least the Edison Shop, 213-215 Second street, the retail store of the Phonograph Co. of Wisconsin, Edison jobber in Wisconsin and Upper Michigan, will continue as such, but it is believed that eventually the wholesale house will concentrate its entire attention to the jobbing business, making the Kesselman-O'Driscoll Co. the exclusive downtown retailer of the Edison.

Clarence J. Orth, distributor of the Puritan in Wisconsin and the Upper Peninsula, and exclusive retail representative in Milwaukee, is doing the best business of his long career as a music merchant. Mr. Orth is one of the heaviest advertisers among local talking machine men and the results have more than justified the effort. Mr. Orth during the present holiday season has been devoting much attention to the publication of the expressions of prominent local musicians concerning the Puritan, and these "home" endorsements have counted for much in the sales he is piling up. Mr. Orth recently took practically a week off late in November and attained the thirty-second degree of Scottish Rite Masonry, and thereupon was made also a Noble of the Mystic Shrine, which adds another well-known musician to the ranks of Wisconsin Consistory and Tripoli Temple.

Brunswick dealers in this city and throughout the entire territory embraced by the local branch of the Brunswick-Balke-Collender Co. are reaping a harvest this holiday season, according to Manager T. W. Kidd.

Not the least important factor in the splendid advance of retail talking machine business in Milwaukee and environs is the co-operative ad-

vertising campaign which the Milwaukee Association of Music Industries is conducting at this time. It is the third drive of this nature, the first having been undertaken a year ago, and the second last spring. The present campaign, which began early in November, will last until after January 1. While the upright player and grand piano is by no means being neglected, the talking machine looms up in this campaign as the feature. The campaign embraces two large display advertisements each week for ten weeks, and about one-half of the "copy" relates principally to the phonograph. Stress also is laid upon talking machine records and music rolls as a broad influence in selling machines by pointing out the wonderful array of talent that is available to music-lovers, once they are possessed of the instrument. The results of this and the previous two campaigns have firmly convinced the Milwaukee trade that co-operative advertising is without doubt the best trade stimulant that has ever been invented.

Milwaukee dealers have not been satisfied to merely participate in the general co-operative campaign, but supplement and re-enforce the collective advertising with individual displays.

Miss Helen Gunnis, manager of The Music Shop, 312 Grand avenue, representing the Starr and the Columbia, recently was made a member of the Milwaukee Association of Music Industries. Another new member is Mrs. Peter F. Piasecki, 441 Mitchell street, who is conducting her husband's Victor business while he is in France, serving as a lieutenant-colonel in the Thirty-second Division, now called "Les Terribles" by the French. Mrs. George H. Eichholz, head of the George H. Eichholz Co., 551 Twelfth street, has been a member of the association since the death of her husband last May. This trio of talking machine merchants regularly attends every meeting and contributes much of benefit to the discussions.

A. P. Kunzelmann, head of the Kunzelmann-Esser Co., representing the Sonora and Brunswick, was elected president of the Mitchell Street Advancement Association at its annual banquet and meeting on November 23.

The Squier Shop, Rhinelander, Wis., a leading Victor dealer of northern Wisconsin, has been purchased from Mrs. Carrie Squier by J. D. Shumway, formerly of Ladysmith, Wis. The latter is primarily a jeweler but has had wide experience in retailing the Victrola.

Henry L. Sorenson, Neenah, Wis., finds that the talking machine and piano department which he established several years ago has grown to such proportions that he has leased a store building adjacent to his furniture and undertaking store and early in December opened a complete music store, distinct from his other interests.

The National Phonograph and Record Exchange, recently opened for business at 520 East Water street, in this city, buys, sells and exchanges talking machine records and player-piano rolls and features a plan of exchange at 10 cents each.

Miss Julia Wolf, since early summer manager of the Aeolian-Vocalion department of the Edmund Gram Music House, is building up a splendid reputation in that capacity. Miss Wolf is the first young woman to have charge of the department and has brought many new and novel sales methods into play, with the result that the Vocalion phonograph and record to-day rank with any other make in popularity and selling power.

TONE ARMS

Immediate Deliveries

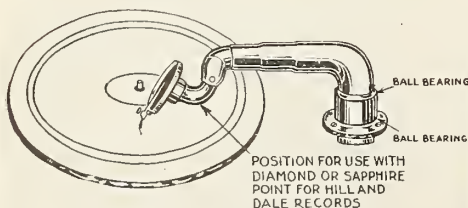

F. C. KENT & CO.

Manufacturers of
**Phonograph
Accessories**

Cor. Mulberry & Chestnut Sts.
NEWARK, N. J.

HOW THIS INDUSTRY HELPED THE NATION'S WAR PROGRAM

Unit Construction Co., of Philadelphia, Took Notable Part in the Manufacture of Thousands of Aeroplanes for Army and Navy, Using Famous Unico Trade-Mark

While not generally known to the public, the talking machine and piano industries have been very actively connected with the air program of this country since its entrance into the world

construction and quality of workmanship and materials are absolute requirements. That the Government exercised the most rigid inspection over aircraft production is demonstrated by

propellers, wings, flying boats, etc., being continued under supplementary contracts as fast as the original contracts were completed.

The entire Unit organization was imbued with an intense spirit of patriotism born of the fact that everyone, from the executives down, realized that every propeller, boat or wing sent over by this company would bring the war to an earlier termination.

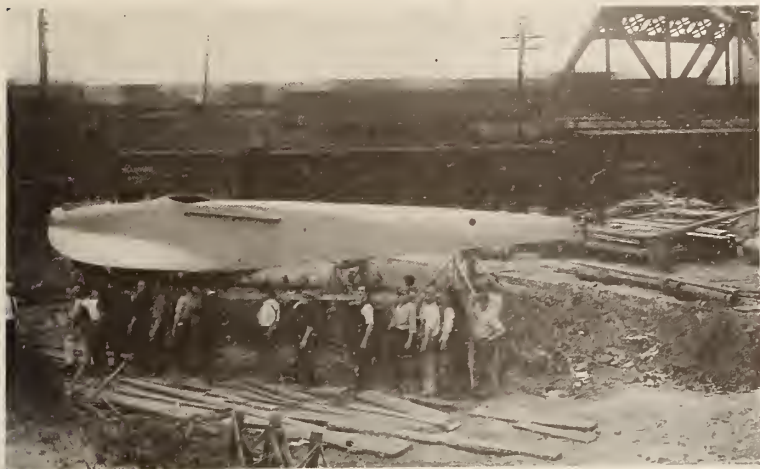

Flying Boat Leaving Unit Co. Plant



100 Mahogany DeHaviland Propellers

conflict. Practically 75 per cent. of the entire aeroplane propellers required by the Bureau of Aircraft Production and the navy department have been furnished by manufactories allied with the piano and talking machine trades, these concerns including the following: Hallet & Davis, Hardman, Peck & Co., Shoninger Co., Starr Piano Co., Packard Piano Co., Unit Construction Co. The Victor Talking Machine Co. devoted a very large percentage of their facilities to the production of metal parts and aeroplane wings for the navy department. The Unit Construction Co., of Philadelphia, turned its entire manufacturing facilities over to Government production, while their new plant, which covers a city block in area, was still in course of construction. During the past year the Unit Co. has produced over 25,000 propellers of various types in addition to large contracts for flying boats and aeroplane wings, each one of which carries the "Unico" trade-mark. The Huns have therefore had a very practical demonstration of "Unico Service."

the fact that more than thirty inspectors were stationed at the Unit plant. In addition to this governmental inspection the Unit Co. maintained a complete inspection force of its own.

The large production demands of the Unit

The following is typical of the service asked from and given by the Unit Co.: On July 25 a contract was placed for 6,000 propellers of a special type, with the advice that General Pershing had requested a shipment of 500 by August 1, or within just one week. While it appeared at first impossible of accomplishment, a special double shift was at once organized, working twenty-four hours a day and before 12 o'clock midnight of August 1 the 500 propellers were completed, boxed and ready for shipment, each one having the official governmental acceptance stamp.

As the Government's program necessitated the commandeering of practically all available cabinet woods, including mahogany, walnut, quartered oak, birch and spruce, production of pianos, talking machines and furniture has been for the past year necessarily curtailed by lack of materials as well as shortage of labor. Now both material and labor are again abundant and with the demand many times in excess of the supply the coming year will witness a volume of business in talking machines and pianos that will make the record of previous years insignificant in comparison.

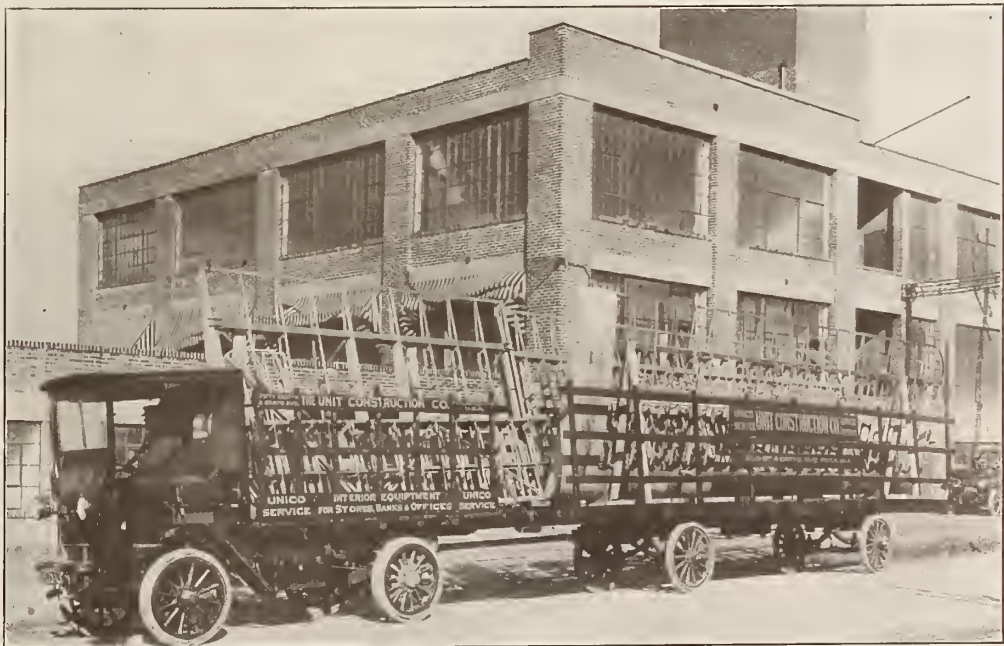

Unit Construction Co.'s Truck and Trailer Loaded With Aeroplane Wings

In the manufacture of propellers, as well as all other aeroplane parts, accuracy, dependable

Co. by the Government necessitated working day and night, Sundays and holidays, and the employment of hundreds of skilled artisans. That they were able to render exceptional service is indicated by the fact that they were kept in continuous production to maximum capacity by the Government, every class of production,



Partial View Unico Propeller Department



Hydro-Planes in Course of Construction at Unico Plant

It Fascinates! Sells the Records You Have in Stock!

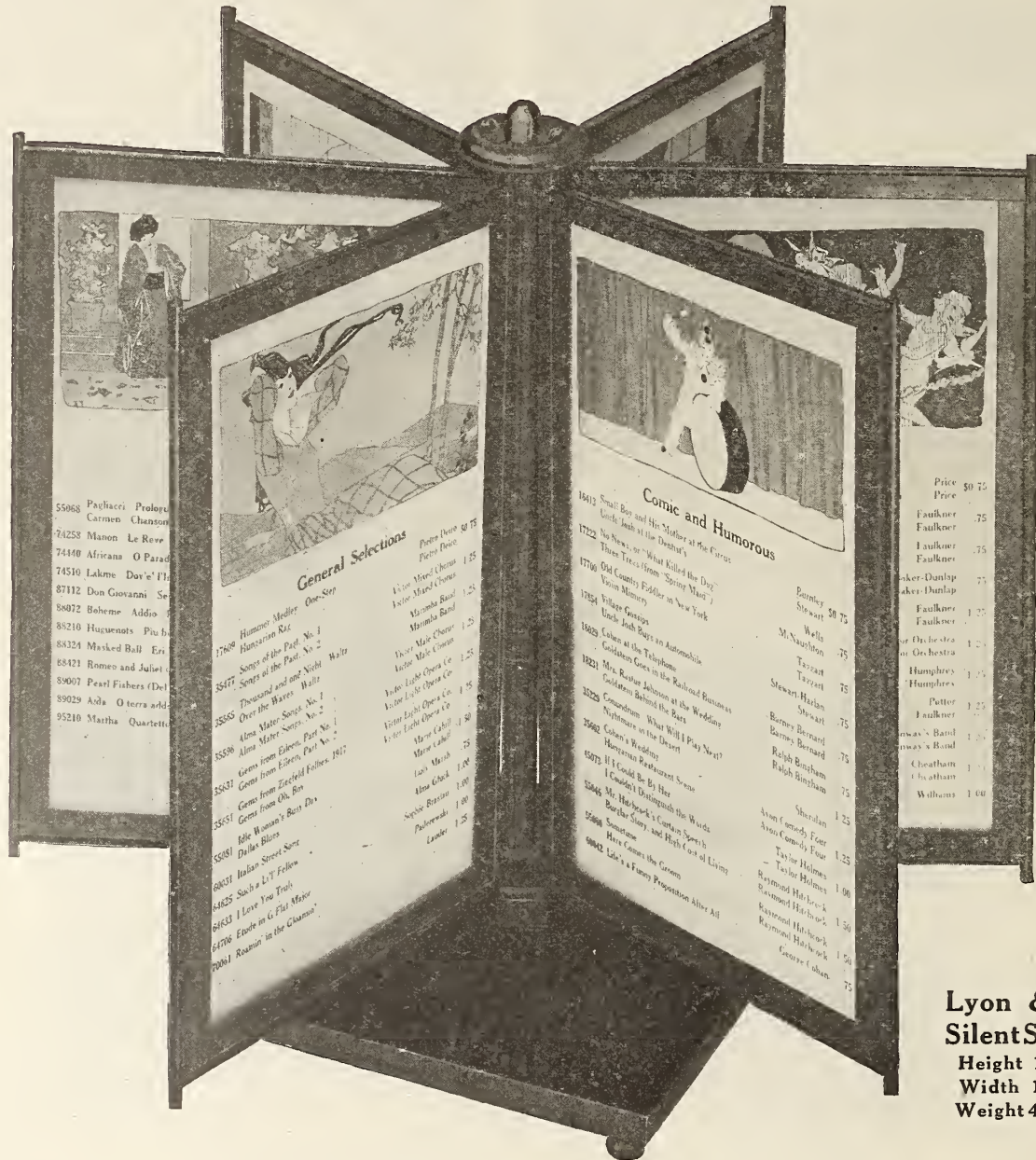

**Lyon & Healy
Silent Salesmen**
Height 13 inches
Width 14 inches
Weight 4 1/4 pounds

MADE of metal. Finished in black equipped with 6 revolving double faced panels — 12 sides. Panels are artistically printed in 4 attractive colors with a sketchy illustration at the top.

Placing several of these **Silent Salesmen** in your Record Department will enable you to sell more records to every customer.

Price complete with two extra changes of cards \$9.00.

LYON & HEALY

Victrola Distributors

CHICAGO

FROM OUR CHICAGO HEADQUARTERS

E. P. VAN HARLINGEN,
Manager

World Office
Republic Bldg., 209 South State St., Chicago
Telephone: Wabash 5774

CHICAGO, ILL., December 9.—With all restrictions taken off the talking machine industry, the manufacturers are tearing into the work piled high before them and trying to dig themselves out from under the heaps of orders on file. In many instances manufacturers in Chicago have managed to get enough help to enable them to put on three shifts. Other manufacturers are not quite so fortunate; nevertheless, they are working and turning out as much goods as they possibly can.

Regardless of make or fame, the talking machines are being manufactured and sold in Chicago in quantities which a year ago would have seemed preposterous or far beyond the wildest dreams. Of course, quite a number of the machines being turned out in large numbers merely have the looks, but the conscientious manufacturer is turning out goods in which looks are only a secondary consideration, quality being primary.

The wholesale dealers are still doing their level best to apportion their goods with judicious care, and whether or not an order comes in from a "best" customer, all are handled the same way; that is, "first come first served."

There is no way of even beginning to estimate the amount of machines that could be sold during the holiday season. It seems that everyone who has the price wants a talking machine and is willing to pay for it, regardless of terms or initial payments. Although the curtailments are off, the time between the final announcement of this and the holiday rush has been too short to enable the wholesale men to get the goods and deliver them.

The present indications are that the trade will not be back to its normal status much before the latter part of February or the first of March. That is to say, the wholesale man will not be able completely to clear up his books and have all dealers satisfied before that time. Even this looks doubtful at present in some cases.

The same situation applies to records. Although record shipments have increased materially in the last two weeks, they are by no means coming in in sufficient numbers to take care of the demand.

Orders being received for records by the wholesale men indicate that the so-called popular numbers or war songs are on the decline.

However, several of the war songs are still in big demand, and consensus of opinion among the wholesale men is that from present indications these numbers are in a fair way to become known as standard selections.

The Retail Situation

"You may rest assured that just as soon as we get the goods your orders will be taken care of." The above is a stereotyped paragraph with which retail dealers are now well acquainted. They have begun to expect this somewhere in all the wholesale man's replies to their letters asking for goods.

The retail man, in turn, has been using the above paragraph as an affidavit when his customers ask why they cannot have certain types of machines or certain records. In Chicago especially, and it is safe to assume the same applies to other parts of the country, the dealer's activities have been largely confined to making excuses for the shortage of goods, and dates for future deliveries. He has been sorely put to it to keep on the good side of his trade.

The dealer has developed mightily during recent matters along diplomatic lines. By that it meant that he has somehow or other managed to keep on the good side of his customer, and has managed to sell the customer something that he didn't in lieu of something he did want.

Then, again, he has learned good business. Formerly, when he had plenty of goods, he was tickled to death to have the customer state his own terms. Since the shortage of goods he has changed. He now tells the customer that this article can be had for so much down and so much per month, and it is safe to say that his terms have increased amazingly when compared with those in vogue formerly. In many instances he has had the nerve to ask for cash down, and has got it.

Another good thing that the curtailment did for the retailer was to compel him to go through his stockroom and dig up records that had been laying there for years. A great many of these so-called "dead" records, with the least bit of pushing, were quickly sold. The only thing the matter with them was that they had been "lost in the catalog," that is, forgotten. They were good numbers, and those who bought them were well pleased with them.

Inside of a couple of months it is believed the

record situation will be back to normal, and Mr. Retailer will have his shelves full again. It is also safe to believe that the record troubles the trade has just gone through have taught the retailer something about pushing records, and the former practice of forgetting what was kept in stock will be a thing of the past. In the future a "lost in the catalog" record will be an unheard-of thing.

Effective Window Displays

The Talking Machine Shop has a Christmas window installed, which is at once simple and effective. The background of the window is taken up by a plain drape of mahogany-colored velvet. On either side of this background is a potted Christmas tree, which is used in the same manner as a pilaster; that is, the Christmas tree is cut lengthwise, so that there is a flat side placed immediately against the drape. There are no decorations on the Christmas tree other than some long streamers of silver and white tinsel. Immediately in the foreground is placed a pedestal, draped with a mahogany-colored velvet throw. Upon this stands a large model of a Victor talking machine in mahogany finish.

Another window that is exceptionally effective and causing much comment is that of the Brunswick Shop. This window is built so as to effect a stage setting of "The Midnight Sun." Immediately in back of the proscenium arch on either side is placed a setting that depicts rocky, stormbeaten cliffs. In back of this is a drop painted in the effect of a skyscape and at the extreme right of this drop is painted the sinking sun. The floor of the set is composed of a large mirror which reflects back the towering cliffs, the sun and the clouds. In the foreground is a light trough, wherein are placed ruby-colored incandescent lamps, which throw a warm, subdued red glow over the entire setting.

Much Timely Propaganda

A great deal has been accomplished in the last few months by the Chicago branch of the Columbia Co. in the way of propaganda. All kinds of advertising stunts have been pulled off and no expense has been spared in promoting this educational work.

R. H. Walley, who has been spreading Columbia propaganda locally, has been pulling some

(Continued on page 83)

NEW PRICES ON

THE "WADE" FIBRE NEEDLE CUTTER

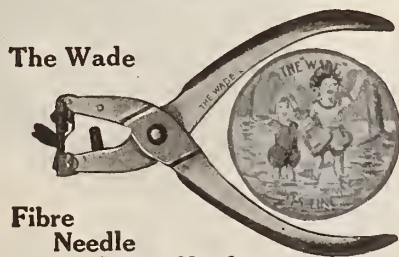

The Wade
Fibre
Needle
Cutter No. 1
Price \$2.00

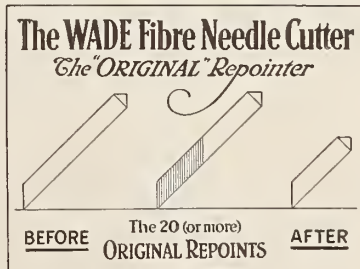

Write for samples and Trade Discounts
or Order from your regular Distributor

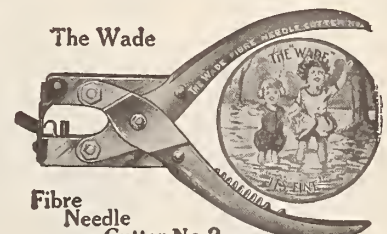

The Wade
Fibre
Needle
Cutter No. 2
Price \$2.50

WADE & WADE, 3807 Lake Park Ave., Chicago, Ill.

Two Great Selling Features Every Brunswick Dealer Appreciates

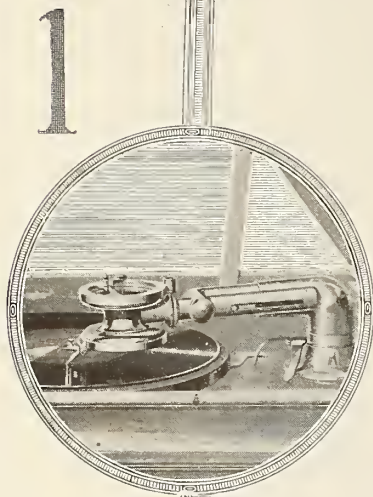

The
Ultona—

*a unique feature
of The Brunswick
Method of Repro-
duction. Now
you can play all
makes of records
at their best.*

THE Brunswick Method of Reproduction has brought about an increased volume of sales. Dealers everywhere join in praising this great idea.

Most dealers realize the drawbacks to old methods of reproduction, and the public, in becoming acquainted with The Brunswick Method, is losing interest in yesterday's standards.

The House of Brunswick is educating the music-loving public to make comparisons. In its advertising in national publications The House of Brunswick is stating compelling facts—which few purchasers care to ignore.

The current advertising campaign spotlights two

features of The Brunswick Method of Reproduction: [1] The Ultona and [2] The Brunswick Amplifier.

A description of the Ultona is enough to make the average buyer anxious to see this new all-record player.

In speaking of The Brunswick Tone Amplifier, we state how The Brunswick attains superior reproduction by complying with acoustic laws, and how we avoid old conceptions.

By studying our advertising, you will note that it is pure selling copy, the exact arguments you and your salespeople can use to great advantage. It is straight from the shoulder, and presents compelling REASONS WHY.



The **Brunswick**
ALL PHONOGRAPHS IN ONE

2

This super-phonograph, as hundreds of Brunswick Dealers will attest, has won high rank as a profit and friend-maker. And its popularity is ever increasing.

We are proud of its reception and of the fine dealer connections it has brought to The House of Brunswick. We have placed our faith and

our resources behind this phonograph and we know that an even greater future is attainable.

More and more The Brunswick is winning friends—everyone who hears it recognizes its worth. We intend to increase this appreciation of The Brunswick—and every Brunswick Dealer will profit thereby.



The
Brunswick
Amplifier

*a new idea in
tone reproduc-
tion, departing
from old-time
crudities. Tones
hitherto lost are
now brought out
in rich clarity.*

The Brunswick-Balke-Collender Company

Branch Houses in Principal
Cities of United States,
Mexico and Canada

General Offices:
Chicago and New York

Canadian Distributors
Musical Merchandise Sales Co.
Excelsior Life Building
Toronto

FROM OUR CHICAGO HEADQUARTERS—(Continued from page 81)

very clever stunts lately that are attracting much attention.

His latest stunt is that being used throughout the Shubert circuit by the various "Seven Days' Leave" companies. In the last act of "Seven Days' Leave" is a churchyard scene, and the



The Columbia on the Stage

dedication of a monument to fallen heroes is in progress. Some words are said relative to the wonderful leadership and bravery of the fallen heroes, and the hero of the play is the major who makes the address. It is during this address that a Columbia talking machine is brought into action, and the Pershing record is used, always bringing forth thunderous applause.

Mr. Walley has also made arrangements for the coming War Savings Stamp drive in Chicago. He has had permission to place in the stamp booths a Columbia graphophone and Columbia records. There are nine booths located on principal corners in the loop and eighteen booths in principal downtown hotels.

crease in the Brunswick business in this section of the country.

Much credit for the success of the fair must be given to M. E. Burton, who is in charge of the company's talking machine department. It was due entirely to Mr. Burton's work that the exhibit proved so successful. He engineered the scheme of exhibiting and made quite a number of good deals, as well as securing a long list of good prospects, which were eventually followed up and successfully closed by him.

The Silent Salesman

The title of this little item is enough to cause wonderment when one stops to trace back in his mind whether he has ever run across a silent salesman in the talking machine business. As a general rule, a talking machine salesman has a reputation of being other than silent. Nevertheless, the trade is becoming more and more familiar each day with the "Silent Salesman," that little stand which is becoming so popular lately, and is to be found on the counters of so many retail stores.

It is merely a little metal pedestal and stand, whereon is placed a dozen revolving panels, containing the monthly bulletins. This little arrangement was designed about a year ago, and first placed on display in the talking machine department of Lyon & Healy. It proved so effective for helping the customer select his records that Lyon & Healy decided to have it manufactured in large numbers and offered to the trade. This was done, and the demand has grown to large proportions.

The stand is made of metal with an ebonized wood base, equipped with rubber feet, so that it can stand on a glass or polished counter without doing any damage. It is made up of six double-faced metal panels, so that twelve display cards may be shown. The height of the stand is thirteen inches, and the diameter of the arc inscribed by the swing of the panels is fourteen inches. The whole stand complete ready for use weighs four and a half pounds.

Demand Steadily Grows

"There is a big demand for high-priced Columbia machines which cannot be filled in time for the Christmas business," says W. C. Fuhri, manager of the Chicago branch of the Columbia Graphophone Co. "We have plenty of small types, in fact, more than we need; but it seems that the laboring classes have more money this year than they ever had, and they are insisting upon higher-priced goods.

"The restrictions upon the manufacture of talking machines were called off a little too late to do any good for the Christmas trade," he con-

tinued, "and I don't believe that the factories will be in a position to take care of the orders on hand until probably early in March.

"I cannot recall a time in the history of the talking machine business since I have been connected with it where there was such a demand for records. The semi-classical numbers are in great demand, and the call for popular selections, while it has been immense, is still increasing. We regret exceedingly that we have not been able to make more prompt deliveries of our goods, but we have been very fortunate in taking care of our trade as well as we have.

Building New Addition to Plant

The Vitanola Co. in an effort to take care of their constantly increasing trade are putting up a new addition to their recently acquired big plant at Cicero. In order to have the addition in working order at the earliest possible moment the company has offered a bonus to the laborers at work on the building. The original contract for its completion is set for December 20, but from present indications, based upon the rapidity with which the working men are laboring, there is no doubt that the new part will be in working order long before that time.

The Vitanola Co. decided upon this new addition because the company's business has been growing to such proportions as actually to crowd them for room.

In the past few weeks they have been working on a ten to twelve-hour shipping basis, that is, they have been supplying the demand for Vitanola talking machines in from ten to twelve hours after the receipt of order. Of course, this company, like all others, has a large amount of orders on hand for future delivery, and they believe that they will be back to normal conditions within the next sixty days. The Vitanola Co. is one of the fortunate companies in so far as help is concerned. They have managed to get help to enable them to put on three eight-hour shifts and are, therefore, working twenty-four hours per day, including Sunday. Nevertheless, they are still far behind with their orders for future delivery, but believe they will soon be able to clean up.

Phono-Grand Demand Increasing

J. P. Seeburg Piano Co. have been obtaining much success with their Phono-Grand. This instrument, which is already well known to the trade, is a combination of an up-to-date talking machine with a modern reproducing piano. L. C. Hirt, who makes a specialty of Phono-Grand throughout the Kansas territory, has been sending many orders for this instrument lately. The instrument is of such a nature that better results are obtained when a salesman makes a specialty of it. Mr. Hirt has been doing this, and takes a sample from town to town, where he has been exhibiting it at all places, such as restaurants, confectionery stores, etc., where it fits in nicely. This method of specializing has more than repaid Mr. Hirt's efforts. He has

(Continued on page 85)



Certificate for Doe & Bill Furniture Co.

The accompanying illustration is of a photograph of the first prize recently awarded the Brunswick department of the Doe & Bill Furniture Co., of Oklahoma City, at the recent Oklahoma State Fair. This company had a decidedly interesting Brunswick exhibit at the fair, which was the means of bringing about a marked in-



UNIVERSAL TONE ARM



**NO SPRINGS
NOR WEIGHTS
TO ADJUST**

**MADE IN
FOUR
LENGTHS**

Patent Applied For

This splendid tone arm equipment has been adopted by many of the highest class talking machine manufacturers.

Start the New Year by using the Empire tone arm and sound box on your machine—it will give your machine prestige and increase sales. We solicit inquiries from high class manufacturers.

Address all inquiries to Chicago Office

**PLAYS ALL
MAKES
OF RECORDS
PERFECTLY**

**WRITE
US FOR
PRICES**

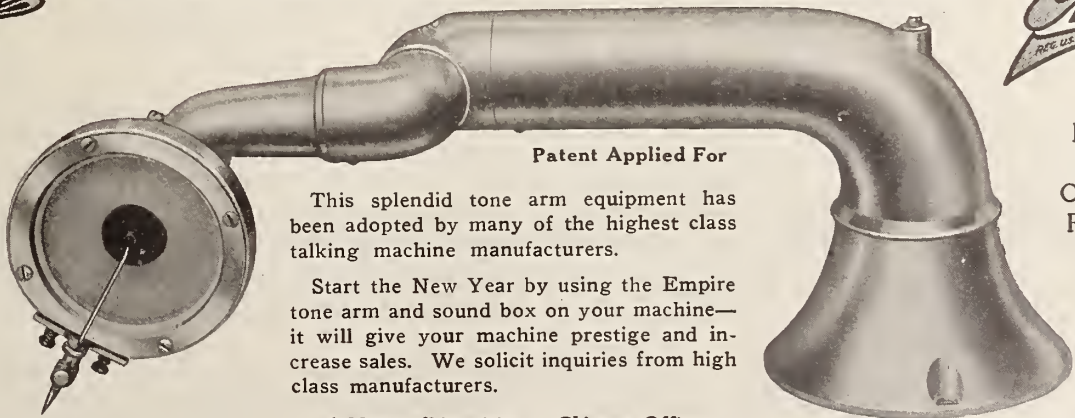

THE EMPIRE PHONO PARTS COMPANY

Sales Office: 425 SO. WABASH AVE., CHICAGO, ILL.
Factory: 1100-1108 W. 9th STREET, CLEVELAND, OHIO

A Great Sales Power

FOR EVERY

PHONOGRAPH DEALER

Every Hiawatha you sell means more sales.

They act as an endless chain.

Honest merchandise can always repeat.

Every Hiawatha Phonograph can be sold with your

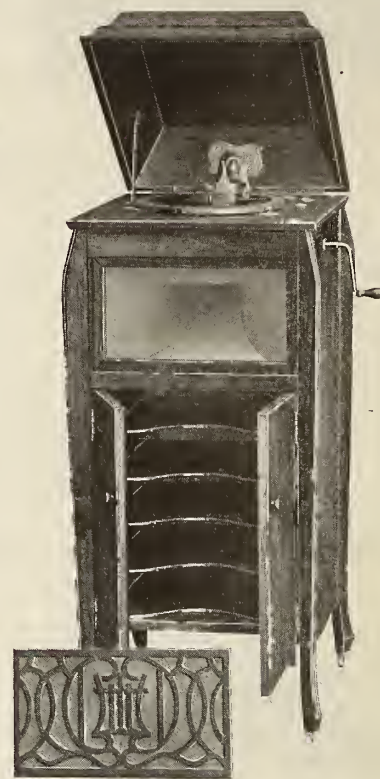

Style 100

stamp of approval and backed up with your business reputation.

Prepare for your Fall business.



FIVE HIAWATHA MODELS: \$50, \$75, \$95, \$125 and \$175

IMMEDIATE DELIVERY

Hiawatha Phonograph Company

209 South State Street

CHICAGO, ILL.



(Pat. Applied For) COVER BALANCE No. 1

Wherever You Go

You are sure to find a dealer somewhere selling a talking machine "without a kick." His business is growing steadily. Why? If you investigate the instruments he handles you will find they are rightly *Equipped*. That's what counts! *Equipment*. Look over your machine's *Equipment* a second time and then just remember that

The Chicago Cover Balance Number 1

is one equipment feature that builds a dealer's business. Can your dealers say they are selling talking machines "without a kick"? If not, write us at once and we will help put your machines on the market—"Kickless."

The cover is "PUT" and "STAYS PUT"

WE ALSO MANUFACTURE CONTINUOUS AND GRAND TOP HINGES

Chicago Hinged Cover Support and Balance Co. 2242-44 W. 69th Street CHICAGO, ILLINOIS

FROM OUR CHICAGO HEADQUARTERS—(Continued from page 83)

made a study of the instrument, and knows whereof he speaks when he is making a demonstration. The Phono-Grand is not only making itself known throughout Kansas, but confectioners, restaurateurs and various other people are especially well pleased with the instrument, and are sending in their orders.

Now Captain Kingwill

First Lieutenant H. S. Kingwill, formerly attached to the Chicago office of The Talking Machine World and The Music Trade Review, and who has been for several months overseas with the Fifty-eighth Infantry, has just been promoted to captain and with his regiment is reported to be somewhere in Luxemburg. This information was conveyed to his former associates in the Chicago office by his uncle a few days ago. Last reports show that Captain Kingwill is well and happy and having a very good time in Nancy, where he was on leave for a few days.

Tel-O-Tone Plans

The Western News Co. has every reason to be satisfied with the reception given the Tel-O-Tone phonographs. Not only the distinctive acoustic features of this instrument, but the attractive case designs have gained the highest approval of the trade. Although the machine has been on the market but a few months, it is already in very strong hands. Dealers and jobbers of progressiveness and natural strength the country over have taken hold of it, and are pushing it aggressively. The company is preparing for an increased output for 1919 with a view of filling promptly the increasing demand from their present connections and for supplying new ones in unoccupied territory.

Good News for Pacific Coast

From all indications the "flu" has not had any effect upon the talking machine business of the Wiley B. Allen Co. stores on the Coast. This company, who several months ago took over the

Far West Brunswick representation, has been making exceptional demands for immediate shipment of goods. When this company took over the Brunswick line they anticipated a certain amount of business, but this business has grown far beyond what they anticipated, as results on the Brunswick order book show.

Their artistic window displays indicate the manner in which they have been introducing the

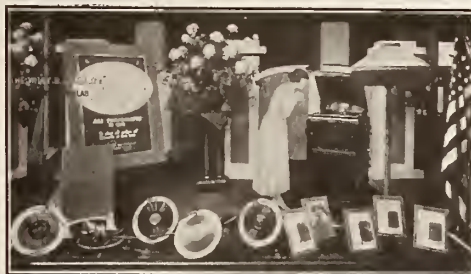

Artistic Brunswick Window

Brunswick, and James J. Black, who manages the talking machine departments for all the Allen stores, has not been overlooking anything along the line of publicity stunts.

Tonofone Representation in Canada

Arthur K. Kempton, of Montreal, Canada, has been appointed by the R. C. Wade Co. to represent Tonofone needles exclusively throughout Canada. Mr. Kempton recently saw the Tonofone ad in The Talking Machine World and made a special trip to Chicago in order to consummate the deal with the Wade Co. Mr. Kempton is a specialist and handles nothing but needles of all kinds and descriptions. He not only does extensive traveling throughout the whole of Canada, but he constantly keeps his three travelers busy. They are always on the job.

Mr. Kempton has recently returned from the front, where he had been for the past three years actively engaged with the Canadian

forces. He received his honorable discharge a short time ago, and was invalidated home, due to his being gassed with chlorine.

Mr. Kempton stated that to his knowledge there are no needles of any kind being manufactured in Canada, and it is for this reason that he makes a specialty of needles and handles every known make and kind.

Christmas Greetings!

The Chicago Talking Machine Co. has mailed out to its many friends in the trade new 1919 calendars. The calendars are illustrated by portraits of either Pershing, Joffre or Foch, and are printed in the new "oilette" process. The oilette process is a new wrinkle in the art of printery and very effective. The prints are made in such a way that the surface of the picture is roughened, following the artist's brush marks, and receives a final finish of a high gloss. The appearance from the distance is that of an oil painting, and cannot be detected from such save upon close inspection.

When the announcement was made by this company that they were sending out their yearly calendars, demands grew to such proportions that the large stock that they had on hand was completely exhausted within twenty-four hours. A repeat order was sent into the printing company for more of the calendars, but the printing company stated that it would be unable to fill the order, as the supply was completely exhausted.

Victor Visitors

Chas. K. Haddon, vice-president of the Victor Co., and R. L. Freeman, the secretary, recently paid a visit to Chicago. The visit of both of these officers of the Victor Co. created some comment in the Chicago trade, as their visit was a radical departure from the policy generally pursued by the Victor Co. Needless to say, their trip, which brought them to Chi-

(Continued on page 87)

TRANSFER NAME-PLATES

We make the Transfer Name-Plates and Trade-Marks for the largest talking machine manufacturers in this country and for dealers in every state.

YOUR NAME, Mr. Dealer, on every machine brings the owner back to you for records and his friends to you for a machine.

Samples, Suggestions and Sketches Furnished Free

THE MEYERCORD COMPANY, CHICAGO

Largest Manufacturers of **DECALCOMANIA** Transfer Name-Plates

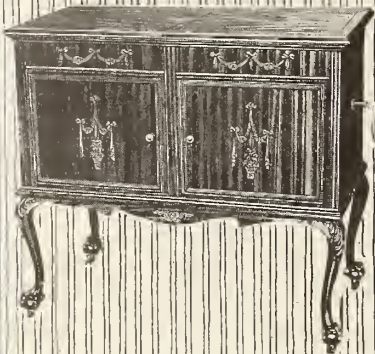

VITANOLA 17, \$300.00
Brown Mahogany



VITANOLA 12, \$160.00
Mahogany or Oak

THE NEW LINE OF
VITANOLA
TALKING MACHINES

VITANOLA
TALKING MACHINES

*continue to maintain their
high standard of quality*

A TALKING Machine to give satisfaction must in these days be very nearly perfect. The public demand much more of the machine than they did even five years ago. These demands, however, are fully met by the Vitanola. The new Vitanola stands now as an example of perfect performance.

¶ The big feature about the New Vitanolas is that they give you an almost unlimited range of new and improved selling points.

¶ There's the improved motor, the enlarged and voluminous tone chamber, the new tone arm and sound box, the exquisitely designed cabinets—really beautiful pieces of furniture.

WRITE FOR PRICES AND TERMS

VITANOLA
TALKING MACHINE CO.

501-509 West 35th Street
CHICAGO : ILLINOIS

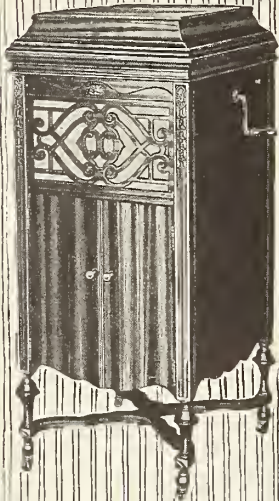

VITANOLA 16, \$200.00
Mahogany or Oak



VITANOLA 10, \$120.00
Mahogany or Oak



VITANOLA 14, \$180.00
Mahogany or Oak



VITANOLA 8, \$90.00
Mahogany or Oak



FROM OUR CHICAGO HEADQUARTERS—(Continued from page 85)

ago and north as far as Minneapolis and then south through the Central West States and back to Chicago, was of immense value to the Victor trade in general and also to the Victor Co., as they were able to gain a great amount of most useful information.

Accessory Business Steadily Expanding

The Lakeside Supply Co. have been receiving during the past month more material than they have had for some time; although material has not come in as yet in quantities sufficient to take care of the orders held on file. Bill and Gus Fricke, the heads of the concern, are both of the opinion that the accessory business is increasing far beyond their expectations. Many new companies have recently started or are about to start in the central and western territory; and from present indications it looks as though Chicago is going to be a main element in the talking machine industry. The greater number of the existing woodworking plants are located within a short distance of Chicago, especially in Michigan, and a great number of new concerns are either locating or have located here. This puts Chicago in a favorable position, as the East is beginning to look more and more to the West for its talking machines, although the West is dependent to some extent upon the East for metal parts.

The Lakeside Co. have been carrying out some careful experiments with tone arms and have therefore been able to add many new features to their well-known Jumbo line.

Both Bill and Gus have become well known to the Western trade as an information bureau. Carrying almost everything known in the accessory line, of all makes and brands, from needles to complete machines, they are filling a long-felt want, and usually can not only give proper information but supply any parts needed.

They have recently taken over a new machine shop and are at present looking around for another one to take care of their trade. At present they have four shops in operation.

Western Branch Increases

The Chicago branch of the Otto Heineman Supply Co. recently took over about five thousand feet of additional floor space in the building they occupy on West Jackson Boulevard. By comparison with the first office they had in this building, their present quarters are approximately twenty times as great. The new addition was taken over principally for the record department and extensive record bins have been installed for the carrying of a large stock of OkeH records.

S. A. Ribolla, who manages the Chicago office, believes that 1919 will be a banner year for the

talking machine industry. He says that the OkeH records are developing fast and he is constantly in receipt of numerous letters from the dealers throughout the country who commend the records highly. The record business is developing much more rapidly than his most optimistic expectations.

Otto Heineman, president of the company, spent the past week visiting the trade in Chicago. **Now With Wilson & Co.**

A. J. Gosswiller, Jr., is now in charge of the retail talking machine department of Thos. E. Wilson & Co. Mr. Gosswiller is a man well known to the local trade and was for ten years connected with the talking machine department of the P. A. Starck Piano Co. After leaving the Starck Co., about a year ago, he went over with the talking machine department of the Kimball Co., but left there several months ago, due to the work or fight order and took a position in an ammunition factory at Dayton, O. At the ammunition factory he was assigned to the turning of 75-millimeter gas shells, and he broke the record one day by turning out 1,126 of these shells. Upon his release by the Government from further work in the munition plant he returned to Chicago, and two weeks ago became associated with the Wilson phonograph department.

Emerson Output Doubled

"Within the past two weeks the output of records by the Emerson Phonograph Co. has been approximately doubled," stated F. W. Clement, manager of the Chicago branch of that company, "and the good shipments we have been receiving recently have enabled us to take care of our dealers' wants for their Christmas trade. The lifting of the curtailment and the sudden termination of hostilities furnished means for opening the gates to the manufacturer and letting him increase his output. This had its effect on the dealer, who had been laying low and not pushing his goods. The reason the dealer didn't push his goods was because he didn't have much to push, and what little he did have he was reserving for his Christmas trade. Now that he has been assured he can have goods, he has been unloading what he had and sending in orders for more, and he is doing all the pushing necessary without any argument on any manufacturer's part. It is not a question of salesmanship any more. It is merely a question of having the goods on hand. For the first time in three months we have put our travelers back on the road. The number of orders they are sending in is surprising. It will, however, take some time to clear up the back orders, but everything looks good for the near future.

Six Best Sellers

The Columbia Co. announce the six best sellers for the month as follows: "Christmas Chimes" and "Cathedral Chimes"; "My Baby Boy" and "You're the Greatest Little Mother in the World"; "Oui, Oui, Marie" and "My Wild Days Are Over"; "They'll Be Mighty Proud in Dixie of Their Old Black Joe" and "If I'm Not at the Roll Call"; "Oriental" and "Texas"; "Beans, Beans, Beans" and "I'm Too Tired to Make Love."

The six best Edison sellers are: "Come Unto Him" and "There's a Beautiful Land on High"; "Hush-a-Bye, Ma Baby" and "Longing for My Dixie Home"; "Fantasie" and "Second Mazurka"; "There's a Long, Long Trail" and "Freedom for All Forever"; "I'm Sorry I Made You Cry" and "Daddy Mine"; "My Sunshine Jane" and "Mother's Old Sweet Lullaby."

Pathé announce the following six best sellers: "There's No Better Use for Time Than Kissing" and "Not You" and "Hit Medley"; "Hindustan" and "Frivolity"; "High School Cadets" and "The Liberty Bell"; "For Your Boy and Mine" and "Freedom for All Forever"; "On the Level, You're a Little Devil" and "That Soothing Serenade"; "A Little Birch Canoe and You" and "Garden of My Dreams."

The six best sellers for Victor records are: "Missouri Waltz" and "Kiss Me Again"; "Smiles" and "Rose Room"; "Oh! How I Hate to Get Up in the Morning" and "Oh, Frenchy!"; "I'm Sorry I Made You Cry" and "One Day in June"; "The Last Long Mile" and "K-K-K-Katy"; "Just a Baby's Prayer at Twilight" and "On the Road to Home, Sweet Home."

Emerson announce the following six best sellers for the month as follows: "Rock-a-Bye Your Baby With a Dixie Melody" and "Big Chief Killahun"; "Smiles" and "You Keep Sending 'Em Over"; "Blue Rose" and "Ful-o' Snap"; "Hindustan" and "Ange D'Amour"; "National Emblem" and "Gate City"; "Cleopatra" and "K-K-K-Katy."

A New Attachment for Edison Disc

The Combination Attachment Co., of 20 East Jackson boulevard, this city, announce that they have perfected an entirely new universal attachment for the Edison disc machine. It is simple to operate and perfect in construction. Being different from others, it can be operated with the Edison lever and tracks perfectly across the record. It can be turned in an upward position, the most convenient method for changing needles. The attachment actually looks like a part of the original machine, pre-

(Continued on page 88)

We Distribute at Wholesale the OKEH RECORDS

Hill-and-dale cut. Double face,
10-inch size. Retail at 85c.

We Can Fill Your Orders

Monthly Bulletin Mailed
Free for the Asking

Write Us Now!



A Full and Splendid Line of Patriotic Music, Popular Songs, Dance Hits, Musical Comedy, Grand Opera, Standard, Sacred.

GREAT ARTISTS!!

NOW READY

Magnola Talking Machine Company

General Offices

711 Milwaukee Avenue, Chicago

OTTO SCHULZ, President

CHICAGO

Southern Wholesale Branch

1530 Candler Bldg., Atlanta, Ga.

Greetings of the Season to all our Customers and Prospective Customers:

WE wish to thank all for their kind indulgence during our past trying months and hope now that Peace has been established to serve all better. Let us figure on your year's requirements on cabinets, motors, tone arms, hardware and accessories. Don't forget that we can supply ROTOMETERS from Stock.

We also Job the famous OkeH (Heineman) hill and dale records, played with sapphire ball or steel needle. No orders too small for our personal attention or too large for our organization.

Cordially Yours

For a Merry Christmas and a Prosperous New Year

LAKESIDE SUPPLY CO., Inc.
202 S. CLARK ST., CHICAGO, ILL.
TELEPHONE, HARRISON 3840

Bill Fricke SEC.
Geo Fricke PRES.

FROM OUR CHICAGO HEADQUARTERS (Continued from page 87)

senting a very neat appearance, and the reproduction of all makes of records is satisfactory. Records having those disagreeable surface sounds, with the original reproducers can be played almost noiselessly and with a most perfect tone. You have the option of using the most suitable jewel or needle point on the record being played and any volume can be attained.

A Letter to the Trade

The J. P. Seeburg Piano Co., of this city, has mailed a letter to the trade setting forth very succinctly the merits and sales opportunities of the Phono-Grand made by them. The letter in part is as follows:

"We know positively the way to increase your sales—a good side line. A good side line will utilize every part of your spare floor space and will practically double your sales without materially increasing your overhead. A good side line for your store is one that adheres to the

music line. Our suggestion is the Seeburg Phono-Grand.

"The Phono-Grand is a combination talking machine and reproducing piano, both operating electrically. The instrument is of convenient size; its finish artistic, and its utility evident. The talking machine is high grade in every respect. The piano interprets hand-played rolls of world-famous masters. The music is standard. The feature of the piano music is the wonderful expression with which it interprets the selections. The handling of the Phono-Grand will enable you to go after the piano prospects, who heretofore you have been able to reach but to whom you had nothing to sell.

"You have had good customers on your books who always paid promptly, and who you almost disliked to see pay up in full. You can resurrect these customers by selling them a Phono-Grand and take in trade the instrument you formerly sold them. Furthermore, you can always sell them customers' records and piano rolls. The Phono-Grand will increase your scope of activity and double your profits. Its field is unlimited. Get all of the prestige this line insures and write to-day for prices and terms."

They Are Coming Home

President Harry G. Wolper, of the Nightingale Mfg. Co., of this city, is naturally jubilant over the fact that Harry Steiner, treasurer of the company, and Edward Spiro, the secretary, who early showed their willingness to serve their country by enlisting in the Great Lakes, will soon be back at their respective desks. They will find things going very nicely at the plant. Mr. Wolper states that they have every reason to be satisfied with the business done in 1918, in spite of the prevailing conditions. They have added a number of new dealers of the most satisfactory caliber, who are pushing the Nightingale product energetically and in a high-grade manner. He is very enthusiastic regarding the coming year, and is preparing for a notable expansion of their business.

A Christmas Letter

The R. C. Wade Co., which last month made its formal bow to the music industry, is sending out a very interesting little Christmas letter to its trade. The company's advertising propaganda have brought an avalanche of inquiries. In one short month their mailing list, which at the time of their announcement contained a few names, has jumped to hundreds. In order to become better acquainted with their new dealers they have decided to send out the following interesting Christmas letter, which we reproduce in part:

"Greetings—Tonofone, the talking machine needle supreme, is to every manufacturer and dealer in every branch of the phonograph business, and to every music-lover—a priceless boon. Why? Because Tonofone brings out beauties and charms hitherto unknown in the rendition

of 'canned' music, and therefore enhances the value of every talking machine and of every record in the world.

"Prior to November 15 Tonofone was unknown, except to a very few, yet to-day—one short month later—it is easily the sensation of the talking machine world, and it has come into eminence on pure merit—nothing else.

"The wonderful reproductions of Tonofone do not depend on any one of its several distinctive features. Tonofone is materially, mechanically, scientifically and musically correct. Without exactly the right material, treated in exactly the right way and unless that material be made up with the very extreme of accuracy possible in mechanics, this needle and every needle would fail—must fail—to reach the full measure of its purpose—must be a disappointment and a failure.

"Very few people comprehend the complex and composite character of the modern talking machine. Most of us are content to enjoy the delights of this wondrous master instrument, without giving even a thought to the why and how of it. This condition is a lamentable fact, because, to one with even a very limited knowledge of its workings, mere enjoyment becomes absorbing fascination.

"The record is the infinitely delicate storage battery—the heart and soul and source of sound impulse. The reproducer is the mouthpiece. The tone arm, the amplifier, the cabinet—each part, in fact, has its special, peculiar function—yet each and all are powerless in themselves—they lack the life-giving impulse.

"Tonofone is the master key that unlocks all these parts, the link that couples and combines all into one beautiful, harmonious whole and makes the modern talking machine what it is to-day.

"Furthermore, Tonofone is so nicely and pre-

"Orotund" and "Superior" Attachments, Tone Arms and Jewel Points for PERFECT TONE

Recommended by all expert dealers and manufacturers.

The "Best" because they will play all makes of records perfectly, with the least mechanical and surface noise, also most safely.

"Orotund" and "Superior" attachments are scientifically made and perfect in action. **The only attachments which will give satisfaction when operated according to instructions.**

All up-to-date dealers should handle attachments as there are many favorite records in the world's library made in both hill and dale and lateral cut lines.

Attachments made to fit all standard makes of talking machines.

New universal Edison attachment now ready. Plays all makes of records with perfect safety and less surface noise than when played with the original reproducers.

Write for prices and descriptive circular.

Combination Attachment Co.
20 E. Jackson Boulevard
Chicago, Ill.

Equip Your Phonographs With Perfect Automatic Brakes

Samples
\$1.00 Each
Cash with order

State make
of tone arm used



Also made
with long
brake shoe
for 1 inch
offset

Patented Aug. 28, '17

Simple construction and easily attached.
Made in four styles to fit any make of tone arm.

Write for attractive quantity price

PERFECT AUTOMATIC BRAKE CO.
Room 400, 425 S. Wabash Ave., Chicago

FROM OUR CHICAGO HEADQUARTERS—(Continued from page 88)

cisely adapted to its purpose that it not only gives a perceptibly and decidedly better rendition, but does it with the very least possible wear on the record. Which rides the more easily and injures the roadway least? The rigid, iron wheel or the soft, resilient pneumatic tire? Tonofone is flexible, elastic, resilient, musical. Rigid needles necessarily bounce along from wave to wave, skipping some and confusing others. Tonofone runs into and over each little undulation, wears them evenly and picks out and transmits, pure and unspoiled, each and every tone. That is why it is the needle supreme. Get a copy of the November or December Talking Machine World and turn to page 59—it tells how to find out about and secure this wonderful little newcomer in the music world."

Steger Phonographs Ready for Trade
Roy Hinman, manager of the wholesale sales

department of the phonograph division of Steger & Sons Piano Mfg. Co., announced this week that the company has now their productive capacity so organized that they can go after wholesale business in a way they have not been able to do in the past. Heretofore they have only been able partly to supply the demands of the regular and long established Steger piano dealers, but now they have a large number of instruments covering the entire line, coming through at the plant at Steger, and will be able to take on additional representation the first of the year. The line is a remarkable one, embracing no less than nine different models, all distinguished by a beauty and originality of case design, and perfect cabinet work that might be expected from a house of the Steger reputation.

Tonally, too, the instrument is one of distinction, and there are various original features

which deserve the consideration of the trade. One of the most notable is the arrangement by which the simple manipulation of a button in the tone arm regulates the various pressures necessary for the playing of lateral cut, Pathé or Edison records. Another notable feature is the patented sound chamber. It is built entirely of wood and the proportions have been carefully worked out, so that the chamber offers no obstructions of any kind to modify the tone quality.

Announce Their Complete Line

By means of an artistic and original folder, the Vitanola Co. are announcing their complete new line of talking machines. The instruments illustrated in their folder are of their new models, which contain many new and valuable improvements and are announced just in time for the holiday and winter season. The folder

(Continued on page 90)

Performance Counts—

Think what "performance" means to you in the making of sales. To demonstrate to a prospective purchaser and close with him through the successful "performance" of the machine. That's what the Empire will do for you—enable you to sell your patrons quickly and build up a profitable phonograph department.

Let's get together now on the Empire proposition—start the year 1919 by taking up the Empire agency—it will enable you to command every class of trade and you will realize handsome profits on the sale of every machine.



Model CC



Model A-1



The Machine that Plays any Record



The Machine that Plays any Record



You will have no trouble selling Empire records in your locality—we can supply you with all the latest "hits" and you will have a large variety to offer. Look over our January list in the Record Bulletin of this paper and then send us a trial order.



Model B.



Model D

EMPIRE TALKING MACHINE CO.

John H. Steinmetz, President
429 South Wabash Avenue, Chicago, Ill.

PHONOGRAPH CABINETS

FOR THE TRADE

The Panels are of Mahogany. The balance of the woodwork is of Selected Red Gum

OTHER FINISHES CAN BE SUPPLIED

Place Orders **NOW** for 1919 Delivery

LAKESIDE SUPPLY CO., Inc.

202 S. CLARK ST.

Phone, Harrison 3840

CHICAGO, ILL.



The specifications for the three types we offer are:

- TYPE "A"
Height—Width—Depth
45" x 20" x 23½"
- TYPE "B"
48" x 22" x 24"
- TYPE "C"
50" x 23" x 24¾"

We have a limited number of these Cabinets for immediate delivery

Write for Particulars

FROM OUR CHICAGO HEADQUARTERS—(Continued from page 89)

was recently designed by Sam Schiff, of the Vitanola Co. Its cover is a two-page affair, whereon is printed a pen-and-ink illustration of an elaborate doorway. Pasted over this doorway is a strip whereon types of Vitanolas offered are printed. Six models in all are shown, including one of their console type. The coloring of the machines is a soft black, and the background is of gold, surrounded by a narrow strip of red border. The illustrated strip is pasted over the aforementioned doorway, and the caption on the door reads "This door leads to greater opportunity."

Interesting Story of Progress

A. G. Kunde, of Milwaukee, celebrated his



View of A. G. Kunde's Warerooms

tenth year in the talking machine business in November of this year. It was a decade of re-

markable progress. His entrance into the talking machine field was a little store on Fon du Lac avenue, in the outlying districts of Milwaukee. He made a success from the very start and in a year attracted the attention of the Columbia Graphophone Co. to such an extent that when they decided to discontinue their Milwaukee branch they immediately approached him on the subject. He took over the Columbia store on Grand avenue, and with it the jobbers' representation for Milwaukee county. A few months later he moved to his present location at 516 Grand avenue, and in a few months remodeled the store and added immensely to its attractiveness.

Not only does he do a retail business of very large proportions, but he has also established a number of new dealers in Milwaukee and nearby towns. Mr. Kunde has been assisted since the beginning of the business by his wife, a most charming and intellectual woman, who has developed into a saleswoman of distinguished ability.

Welcome Home

Wm. C. Griffith, who prior to his enlistment in the United States Army was assistant to G. P. Ellis, sales manager of the Chicago Talking Machine Co., has received his honorable discharge and will be back on the job at the company's offices by Monday of next week. Upon

enlistment, Mr. Griffith was sent to Camp Wheeler, Macon, Ga., where he received his training and was promoted to the rank of corporal. About three months ago he was selected as a candidate for the Officers' Training School at Camp Zachary Taylor, Kentucky, and since then has been receiving a thorough schooling.

Sympathy for L. C. Wiswell

L. C. Wiswell, manager of the talking machine department of Lyon & Healy, has the deep sympathy of his very many friends in the trade in the death of Mrs. Wiswell, which occurred on Sunday, November 16, at her home, 10534 South Seelye avenue. Mrs. Wiswell had been sick but a short time with pneumonia, succeeding an attack of influenza. The funeral services were held the following Tuesday afternoon at Mt. Hope Cemetery. Mrs. Wiswell is survived by her husband and four children.

Brunswick Activities

C. J. Carroll, who formerly looked after the Brunswick trade in Denver territory, has been released by the Government and is back at his old stamping grounds. For the past several months Mr. Carroll has been working in a Government ammunition factory in Tennessee.

A. J. Kendrick, general supervisor for the Brunswick Co., spent last week in Indianapolis, calling on Geo. F. Standke, manager of the Brunswick Shop in that city.

L. E. Blythe, formerly Kansas City representative for Brunswick, but now a member of Uncle Sam's forces, stationed at Ft. Sheridan, was in town for a few days recently.

Personals and Visitors

V. H. Nelson, manager of the talking machine department of the Wilbur Templin Music House, Elkhart, Ind., was a caller recently.

W. E. Shay, Elyria, O.; S. M. Field, of the George Gloss Dry Goods Co., Little Rock, Ark.; J. A. Hofheinz, of the Bry Bloch Mercantile Co., Memphis, Tenn., were among the recent visitors to the trade here.

A. W. Roos, manager of the St. Louis branch of the Columbia Graphophone Co., was in Chicago recently.

Chas. Kennedy, Columbia representative at Cleveland, spent a few days in Chicago.

Wallace Brown, the live wire Brunswick dealer of Detroit, paid Chicago a visit last week.

Our Repair Department

WE ARE EQUIPPED TO DO REPAIR WORK OF ALL KINDS

Our experts are men of 20 years' experience in the assembling and repairing of all the mechanical parts of a talking machine and are capable of repairing and adjusting any kind of a motor, sound box or any other part of any make of machine.

All work guaranteed to be satisfactory in every respect.

Efficiency and quick service at all times, with reasonable prices.

Send us your repair jobs and they will receive prompt attention

INCORPORATED UNDER THE LAWS OF ILLINOIS

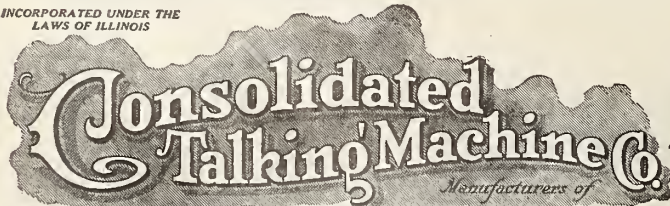

SUCCESSORS TO
Standard Talking Machine Co.
United Talking Machine Co.
Harmony Talking Machine Co.
O'Neill-James Co.
Aretino Co.

High Grade Talking Machines, Disc Records,
Talking Machine Supplies, Etc.

227 W. Lake Street, CHICAGO, ILL.



TRADE MARK
"CONSOLA"

CABLE ADDRESS
"CONSOLA"

REPAIRS

Correct Repairing for the trade

Send your motors by parcel post

VAN DEMARK'S

15 Years at

305 E. 43d ST., CHICAGO

FROM OUR CHICAGO HEADQUARTERS—(Continued from page 90)

NOW SUPPLYING "WORLD" RECORDS

Wide Selection of Numbers for Jobbers Being Furnished by the World Phonograph Co.—This Company Making Distinct Strides

CHICAGO, ILL., December 5.—Under the progressive direction of Ernest C. Cook, who assumed the secretaryship and general managership of the World Phonograph Co., of this city, a few months ago, that corporation has made distinct strides in the volume of output, quality of product and popularity with the trade. This is one of the comparatively few concerns in the coun-



Ernest C. Cook

try that can boast of producing its own product practically in its entirety.

A trip through the plant this week revealed every evidence of prosperity. A large number of the various styles of the World phonographs are in process, and the shipping floor was a busy spot indeed. It is a factory in every sense of the word. In the basement the company manufactures its own shipping boxes. The first floor constitutes an exceptionally well equipped mill room. The second floor is devoted to the general offices and the shipping room. On the third a large force of expert cabinet makers is busily engaged. The fourth floor is devoted entirely to assembling, while the top floor is devoted to the finishing departments.

In the drafting room designs for some very attractive new models which will make their appearance the first of the year were shown with justifiable pride to the visitor.

Mr. Cook also states that the company now has its own motors, tone arms and sound boxes in process of construction, and that they will be a constituent part of the entire 1919 product. The company is getting the distribution of its product in very strong hands, and its lists of jobbers comprises some of the largest, oldest and best financed houses in the country. The officers of the company are highly pleased with the notable advance made by this institution since Mr. Cook assumed the helm.

The company is now able to furnish their jobbers with "World" records. The catalog is a large one, embracing a wide selection of numbers by orchestras, bands and vocal artists of distinction. This will of course be supplemented by monthly bulletins. The label itself is a very distinctive one, being unconventional and tending to fix the attention of the prospective purchaser at once.

THE NEW FULTON-ALDEN MOTOR

Fulton-Alden Co. Expect to Make Shipments From Their New Plant at Waukegan Before January 1—New Motor Technically Described

CHICAGO, ILL., December 7.—Last month's issue of this paper contained the interesting news that the Fulton-Alden Co. had purchased the plant and equipment of the Metal Specialties Co., Benton Harbor, Mich., which has been devoted since its organization to the production of a new type of talking machine motor, as well as to other specialties of like kind.

The Benton Harbor factory has now been moved to the Fulton-Alden Co.'s new plant at Waukegan, which has a superficial area of about 15,000 square feet. Before January 1, according to present plans, the company will be shipping their motors on a regular production basis.

The new Fulton-Alden motor, which will be offered to the trade in this way, comprises many special mechanical features which have been specially worked out by its inventor, William R. Everett, who is well known to be one of the leading experts in the design of such mechanisms. "Its most striking feature," it is pointed out, "undoubtedly is to be found in the vertical governor, in which the centrifugal balls are hung on links instead of springs. It can readily be seen that a vertical governor must have definite advantages over the more usual horizontal design. In the first place, the tendency to twist out of line is wholly avoided, because the balls are held balanced around their shaft, when at rest, by simple force of gravity, and when in motion are compelled to travel at once in a perfect circle. On the other hand, when the balls are horizontally disposed, it is necessary to fasten them to springs instead of links, in order to keep them in place, and the wearing of the springs soon tends to become irregular, throwing one ball perhaps out of line with the others, and tending to give an elliptical instead of a circular path to the distorted ball. This produces noise and upsets the controlling action of the governor, leading to irregular turntable speed.

"The Fulton-Alden motor, in the second place, includes a new gear-train entirely. There is only one intermediate shaft, driven by the spring box gear, and this drives both the turntable shaft and the governor shaft. The latter shaft, in fact, is detached from the turntable shaft, which usually drives it. Thus the governor, the turntable and the spring box are in effect locked together permanently. No change in governor speed can fail to affect directly all the gears of the entire motor. Moreover, this type of construction permits the assembling of the motor with varying sizes or numbers of spring boxes, so that the production of a varied line for all kinds of talking machines is made possible very economically and satisfactorily.

"It must also be mentioned that spiral cut gears are employed instead of the usual spur gears with worm gearing for the governor. The inventor says that he did not desire to depart radically from accepted types of motor, but to eliminate mechanical faults and especially to improve the methods of assembly and production."

Several other features, including the new winding device, the back stop, etc., will be described, with illustrations, later.

R. E. Quinn & Co., Elizabeth City, N. C., has opened a large talking machine department, and has secured the Columbia agency.

COLUMBIA LINE IN ROANOKE, VA.

Hobbie Bros, Inc., the prominent music house of Roanoke, Va., has secured the agency for the Columbia Grafonolas and records, formerly held by the Huntley Furniture Co., that city. Hobbie Bros. have arranged to open a substantial department built with sound-proof rooms and other facilities.

TO MAKE TALKING MACHINES

The H. L. Main Furniture Works, Hagerstown, Md., has been purchased by Dr. Charles F. Anck, of Philadelphia, who is organizing a company for the manufacture of talking machines.

LOCATES IN DALLAS, TEX.

E. Keith Lyons, formerly manager of the talking machine department of Herman-Straus & Sons Co., Louisville, Ky., is now in the business with his father in Dallas, Texas.



The Cabinet of the Phonograph
That's to Be A Real Instrument

Must be more than
a Pretty Box.

SINGER CABINETS

are handsome—see the design—and besides they're built to last, the qualities that preserve the handsomeness are built in. Without those qualities lasting satisfaction cannot be given.

We're Skillful Wood Workers

—and we know woods, we know what to use and what to avoid to insure maximum lasting qualities.

Cabinets Built from Your Blue
Prints or We'll Submit Designs

Prices fitted to your selling proposition.

Why Worry Along on a Hunch?
Our Knowledge is A SURE Thing.
Get In Touch With Us To-day.

Singer Talking Machine Co.
MILWAUKEE WIS.

THE LATEST INVENTION IN THE PHONOGRAPH INDUSTRY

"THE ALL-IN-ONE"

An attachment for VICTROLA and COLUMBIA, which, when once attached to the tonearm, plays permanently all makes of disc records without any further change of the position of the reproducer.

Retails at \$1.50. Write today to

F. J. M. KAUMANN, Sole Representative, :: 405 Westminster Building, CHICAGO



The New Edison Diamond Amberola
Model 75

THE NEW EDISON DIAMOND AMBEROLA LINE

represents the

Highest Quality

at a

Popular Price

and offers

a Complete Selection

of Instruments

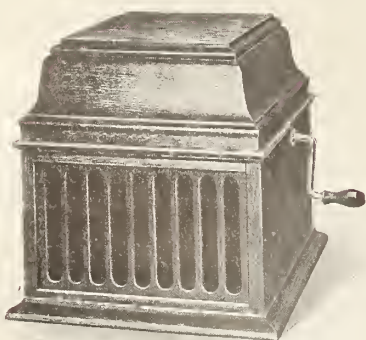

The New Edison Diamond Amberola
Model 30

THOMAS A. EDISON, Inc.
Amberola Department
ORANGE, N. J.

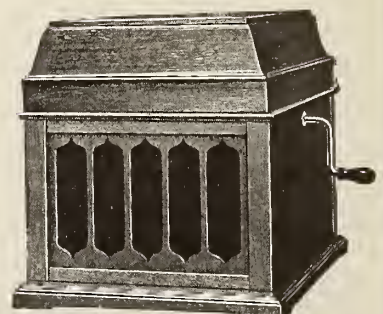

The New Edison Diamond Amberola
Model 50

This Christmas it isn't a question of whether or not to buy a Grafonola—but *what* Grafonola to buy.

Columbia Graphophone Co.
NEW YORK



ISSUE NEW RECORD CATALOG

Complete List of Paramount Records Offered in Attractive Volume Just Off Press

There has just been issued a new and most attractive Paramount record catalog, copies of which are now being distributed to the trade. The new catalog is gotten up in an elaborate manner in keeping with the Paramount policy and is supplied with a cover of rich green, upon

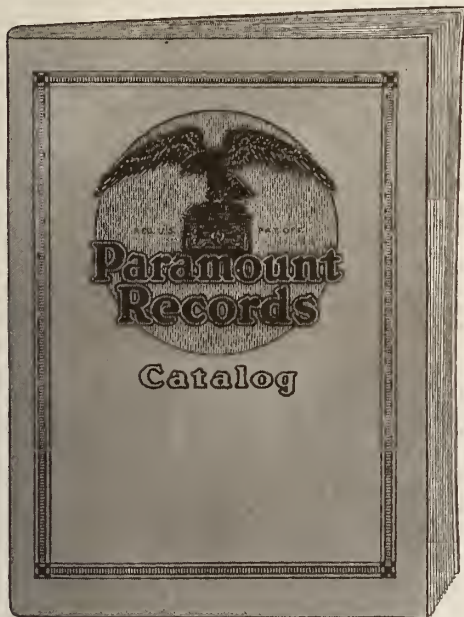

Cover of New Paramount Catalog

which the Paramount trade-mark is printed in gold and black. The effect is decidedly attractive.

The reading matter consists of several pages of general information relative to Paramount records and the way to play them. Then follow some lists arranged to assist purchasers in their selections, a help that is often much appreciated.

Every record is listed alphabetically and again cross indexed under the name of the artist or organization producing it. Throughout the list free use is made of pictures of Paramount artists which add interest and variety to the many pages.

The size and contents of the catalog reflect the progress made by Paramount. The long list of titles comprises favorite popular and classic numbers, so paired as to make each record a live one. From late reports sales are climbing steadily, indicating that the records are making good.

IN NEW LOCATION

William H. Avery, piano and talking machine dealer of Concord, N. H., has moved his store from the old location at 5 Capitol Street, to larger and handsomer quarters at 18 Pleasant Street.

REPAIRS

TALKING MACHINE TROUBLES AND HOW TO REMEDY THEM

Conducted by Andrew H. Dodin

[This department of The Talking Machine World is designed for the service of all classes of our readers, including those who make, and those who sell, talking machines. Andrew H. Dodin, who conducts this department, has a wide and enviable reputation as a repairer of talking machines and conducts an exclusive talking machine repair shop at 176 Sixth avenue, New York. Tell him your troubles through The World and he will help you if possible. The service is free.—Editor.]

SOUND BOXES

(Continued)

The Edison Diamond Disc Sound Box

No doubt every dealer is familiar by sight with the Edison Disc sound box, but I think it would be safe to say that not over 10 per cent. of them have ever had the opportunity of looking inside of one, to see how it is made and what it is made of.

There are three points to consider about this sound box (so different from the usual lateral cut record sound box) that they command our attention at first glance.

The first important fact to consider is that the box is constructed of two main parts—the top, or cup, containing the diaphragm and tone tube connection, and the bottom, or floating weight—carrying the diamond point set in a swivel stylus arm. Second, unlike the lateral cut record sound box, the full weight of the sound box does not rest on the playing point, the weight of the sound box cup is borne by the sound tube, which is carried across the record surface by means of a spiral feed, leaving only the four-ounce floating weight to press against the record through the diamond point. Third, there is not a rigid connection between

the stylus arm and the diaphragm, the medium used is a silk or cotton thread.

The diaphragm is made of several layers of rice paper saturated with a chemical composition, heated and pressed to a thickness of five one-thousandth of an inch. To overcome blast a thin piece of cork is shellacked to the underneath side of the diaphragm. On the top of the diaphragm, over the center hole, is cemented a little ivory fixture to which the upper end of the flexible cord is fastened. The diaphragm is placed between two gaskets of solid rubber, which are tightened by a screw clamp ring.

The floating weight is attached to a loose screw at the back end of the sound box cup casting by a light, flexible spring. This arrangement of suspension allows of motion not only perpendicularly, but also laterally. Both motions are checked by means of a pin in the floating weight engaging the limit loop attached to the front end of the cup casting. When the sound box is raised from the record this limit pin and loop act as a support for the floating weight, taking away all pull on the diaphragm when the box is not in use.

When the sound box is lowered to the record for playing the floating weight pressing down on the stylus arm causes the flexible cord to be pulled taut and so permits the vibrations to be carried to the diaphragm.

The permanent diamond points carefully ground to fit exactly the groove of the record which is cut at 150 lines to the inch and is commonly called the hill and dale cut.

From the Repairman's Standpoint

From the standpoint of the repairman, about the only troubles he has to contend with are—the loosening of the ivory fixture from the diaphragm—a broken diamond point—broken swivel spring or the tightening of the swivel screw to which the floating weight spring is attached.

TEN INCH

Operaphone

PLAY WITH STEEL NEEDLE
ON ALL UNIVERSAL TONE ARM MACHINES

Records

COMPLETE CATALOGUE SENT ON REQUEST

OPERAPHONE CO., INC., LONG ISLAND CITY, N. Y.

PERIOD OF UNPARALLELED POPULARITY FOR PHONOGRAPH

That Is What the Future Holds for the Industry in the Opinion of John Cromelin, General Sales Manager of the Otto Heineman Phonograph Supply Co.

"The phonograph is about to enter on a period of unparalleled popularity as a national household article, and the phonograph industry is about to enter upon a period of unparalleled volume of sales," said John Cromelin, general sales manager of the Otto Heineman Phonograph Supply Co., Inc., in a chat this week with a representative of *The World*.

"During the period of the war the demand for phonographs and records was enormously in excess of the ability of the entire industry to supply. The war brought home to the entire world the importance that wholesome and inspiring songs and music have in maintaining the best efficiency of civilian and soldier alike, and it brought home, further, the fact that the incomparable vehicle for these songs and music is the phonograph. Every manufacturer was oversold far in excess of his capacity. The recognition of the importance of the phonograph as the universal entertainer and morale and efficiency-builder is shown not only in the tremendous and insatiable demand that came from the public, but also in the treatment of this industry by the Government. The restrictions which were imposed upon the phonograph industry were reluctantly and tardily imposed and they were nothing like so severe as restrictions on many other industries.

"Why was this? Because the Government recognized the great value of the phonograph in keeping the men in the camps and the men and the women in the factories and in the homes content and efficient. Because of this the restrictions on the phonograph industry were moderate and were imposed at such a late period that they in themselves did little to interfere with the production of phonographs and records. There was very substantial interference with production, but this came from the shortage of material and

labor, due to the enormous total production of all kinds of war and peace supplies.

"The laboring classes of the country during the war period made money at a rate that they never dreamed of, and the first thing that they



John Cromelin

turned to for the enjoyment of their new surplus was the phonograph.

"Now we are entering a situation where, owing to the enormous tasks to be performed by the world, the demand for labor will continue for an indefinite period to be nearly if not fully as great, as it has been; therefore the prosperity of the working classes will continue. This means that the purchasing power of the individual in the United States will remain high and

the demand for phonographs and records will therefore keep up the way that it has done in 1917 and 1918—but with this big difference—that now peace industries have come to have their turn in getting supplies of material and labor the phonograph industry will be able to make deliveries of the quantities of goods the public want. This, taking into consideration the great increase in demand, will mean an enormous volume of phonograph and record business as compared with any figures that the industry has ever experienced.

"One of the biggest factors that will contribute to the great broadening of volume of the phonograph and record business is the general interest being taken in this industry by successful and long-established companies in other lines of the mercantile world. A few years ago the phonograph trade in this country was in the hands of a few companies who had been established for a great many years. About that time the foundation was laid for bringing into existence a number of other manufacturers of so-called 'independent' machines. In the beginning, this industry was a small and precarious one. A few old concerns were firmly established in the public mind, and it was very hard for other concerns to get a start, but after a year or two a number of the best houses, who had started manufacturing their own phonographs, had laid a pretty good basis of success and finally, in the nearly two years that the United States has been at war, the best of the newcomers in this field have grown so rapidly and built up a turnover of such quantities as to exceed even our sanguine and optimistic expectations.

"I don't know whether you realize it, but it is a fact that one of these manufacturers, starting only two or three years ago, is selling one hundred thousand machines a year, and not cheap machines either. They are machines that average to the public between \$75 and \$90. There are three or four others that are selling between fifty thousand and sixty thousand machines each

The Veritone Phonograph



MODEL 100

A Quality Product

The Veritone Phonograph is not only mechanically efficient and artistic in appearance, but it assures the dealer a large margin of profit. The cabinets are of fine workmanship, and the equipment of the machine is of the best throughout.

Built in six styles retailing from \$55.00 to \$215.00. It plays all the makes of disc records, and is equipped with many individual features.

To Responsible Dealers

We know you are looking for a phonograph of quality combined with a profitable proposition. In order to prove to you that we have the best you have yet seen we will send you one of our machines on approval. Let us know where to send it.

Veritone Talking Machine Co.

145 West 45th St.

New York City

per year, and altogether know this newer branch of the phonograph manufacturing industry has already reached a stage where the number of machines turned over is not far short of the trade done by the old-established companies. This volume of business has been attained notwithstanding the severe handicap upon production in 1917 and particularly in 1918. All of these manufacturers could have sold between them hundreds of thousands more machines if they had only been able to produce them. They will do this in 1919, and finally and permanently establish the talking machine industry upon a broad foundation.

"An interesting feature of the growth of the phonograph industry is the development of the record business. This is evidenced in the phenomenal success achieved by the 'OkeH' record. Our company realized for a long time that the absence of a record supply available for the dealers handling the newer machines was a serious handicap to the business, and a few months ago we brought out our 'OkeH' record, which sprang into instant popularity, owing to the fact that it was, in our opinion, the first good record which had been offered to the dealers on a basis which enabled them to handle it without being obliged to carry a corresponding line of machines. We have been oversold on our 'OkeH' record from the beginning, but we are adding greatly to our facilities, and are getting into position to deliver 'OkeH' records in the unlimited quantity that seems to be demanded. This record supply will be of the greatest help to the dealers handling the newer machines and therefore to the manufacturers of these machines.

"In the very few months that the 'OkeH' record has been on the market, we have had assurances from many phonograph manufacturers

GRAFONOLA FOR THE PRESIDENT

Grand Salon of "George Washington" Has Type L-2 Grafonola for President Wilson's Pleasure During His Historic Trip to Europe

When the ocean liner, the U. S. S. "George Washington," left New York Wednesday morn-



Loading Grafonola for President's Ship with his party aboard, bound for the peace conferences, it was well provided with music, for in addition to a brass band for concerts on deck and an orchestra to play during meals, a Columbia Grafonola with a library of one hundred Columbia records was placed on board the liner.

The type L-2 Grafonola was the instrument honored by being chosen for use on this memorable trip across the Atlantic, and according to wireless advices received at the Columbia executive office this Grafonola and the Columbia record library are contributing materially to the enjoyment of the Presidential party. The instrument was placed in the grand salon, and the artistic beauty of this particular Grafonola design harmonizes completely with the magnificent furnishings and decorations of this salon. Included in the library of records furnished for the amusement of the President and his party were several Columbia records made by Miss Margaret Woodrow Wilson, daughter of the President, who records for the Columbia library exclusively.

A type L-2 Grafonola with a library of one

VAN VEEN "BED-SET" BOOTHS



Prepare for the Greatest Talking Machine Trade in History

WRITE FOR A COPY OF OUR NEW CATALOG

It will give you an idea of the attractiveness of Van Veen "Bed-Set" booths, and enable you to make plans for the great "after-war" business that the talking-machine industry will enjoy.

Arthur L. Van Veen & Co. 47 West 34th Street, New York
TELEPHONE . . . GREELEY 4749

who are large users of our motors and tone arms that this record has been of substantial assistance to them in the sale of their phonograph.

"All in all, the future of the entire phonograph industry can only be described as mag-

nificently brilliant. I have been hearing the statement made 'the phonograph industry hasn't started yet' for so many years that it has become a hackneyed phrase, but I must confess I never felt that this phrase is so true as it is today."

hundred Columbia records was also placed on board the U. S. S. "Orizaba," which left Hoboken on Sunday with a party of three hundred and fifty newspaper men, press correspondents, photographers, etc., bound for the peace conferences at Brest. These newspaper men will undoubtedly be delighted with the entertainment afforded by the Grafonola and the Columbia records.

Parham Werlein, head of Philip Werlein, Ltd., the Victor wholesalers in New Orleans, La., heads a committee of Elks who are working for the "Times-Picayune" Christmas Doll and Toy Fund, to provide toys for the poor children.

REPORTS BIG VOCALION TRADE

CINCINNATI, O., December 8.—Manager Byars, of the local Aeolian store, reports the closing of the biggest November Vocalion business ever done in the history of the Cincinnati store.

Now that the armistice has been signed and the war is practically over, the public are no longer uneasy, and they seem to be in a splendid buying mood.

At the request of Miss Beth Lydy, the musical success of "Rainbow Girl," Mr. Byars placed at her disposal in the Hotel Sinton a Vocalion. Miss Lydy is a staunch admirer of this instrument and rents one in each city she visits.

SERVICE FOR THE JOBBER



Write today

Seven Patterns in stock
STYLE FOR EVERY DEMAND

Cabinets only
or completely equipped
SELL BEFORE YOU BUY

Send us Motors; we
install and ship
your

Customer Direct

No freight
No handling
Save you \$4.00 to \$5.00.
each Cabinet

Established 40 years

JOSEPH KNITTEL SHOW CASE CO. - - - Quincy, Ill.

IMPORTANT NOTICE

TO THE AMERICAN TRADE

The Sterno Manufacturing Company
19 CITY ROAD LONDON, E. C. ENGLAND

Manufacturers of the world known COMPACTOPHONE—the most complete portable gramophone extant—beg to announce the conclusion of arrangements for the EXCLUSIVE SELLING RIGHTS IN THE UNITED STATES OF THE

High Grade Motors Manufactured By **Mermod Freres** St. Croix Switzerland

WONDERFUL MECHANISM

These motors represent the acme of workmanship and quality. Each part is made to the finest gauge limits and assembled to run with the precision of a watch—silent and true. Messrs. Mermod Freres is an old established Swiss manufacturer. Back of their motors are years of hard practical experience. The experimental stage was left behind a decade or more ago. Reliability and quality is therefore assured.

DIFFERENT MODELS

Mermod Freres motors comprise several types—single and double spring worm and pinion-gear drive, the very latest and scientific method of construction.

CONSULT US

Before placing your orders elsewhere consult us as to prices and terms of trading. We are out for quick shipments and prompt delivery direct from the factory to the buyer.

SPECIAL TERMS TO JOBBERS

Within the near future it is proposed to establish
A CENTRAL DISTRIBUTING DEPOT IN NEW YORK
Meanwhile trade enquiries should be directed to

THE STERNO MANUFACTURING CO.
19 CITY ROAD LONDON, E. C. ENGLAND

Are you featuring a Gift Box of Columbia Records? Many dealers are doing a big business with this idea.

Columbia Graphophone Co.
NEW YORK



THOS. A. EDISON SAYS PEACE WILL BRING PROSPERITY

Noted Inventor, on Laying Aside War Work, Calls Upon Business Men to Go Ahead With Confidence in the Future—Opportunities for Patriotic Service Are Still Before Us All

Thomas A. Edison, president of Thos. A. Edison, Inc., and honorary president of the Naval Consulting Board, in a statement to his business associates and friends, discusses the present situation and the outlook for the future as follows:

"I expect to be mustered out of Uncle Sam's



Thomas A. Edison

service before long and it will seem mighty good to be on the old peace job again.

"What does the first year of peace have in store for us? I have been asked to attempt to answer that question.

"There are those who fear a business depression. The surest way to bring on a depression of business is to nurture fears and act hesitatingly. We now have a national financial system which is capable of meeting practically any situation that can arise and we do not need to fear difficulties from that quarter. Our farmers have harvested an enormous crop, and the assurance of good prices, together with more plentiful labor, make certain a heavy planting

next year. The only thing needed to insure a year of great prosperity is a determination on the part of every business man, big and little, to go ahead with absolute confidence in the future.

"The business man of this country must see to it that employment is provided for our war workers and returning soldiers. There will be opportunities for patriotic service in this connection, and I hope all of you will do your part and encourage others to do likewise. We have shown our service stars and worn our Liberty Loan buttons with pride. Let us take equal pride in doing our share to make employment for the men who have worked and fought to win the war.

"Every business man should speed up his sales organization. The salesmen of this country can do more than anyone else to keep the wheels of industry turning at full speed. The salesman had to take a back seat during the war, but his time has now come. Give him a chance."

EFFECT OF FLU ON PORTLAND TRADE

Talking Machine Business Goes Right Along Despite Handicap of Epidemic

PORTLAND, ORE., December 8.—Although all stores closed at 3.30 p. m. during the "flu" epidemic, which happily is about over, nearly all dealers say it made very little difference in sales. Miss Hayes, in charge of the G. F. Johnson Co. phonograph department, says business was excellent all during the epidemic, and the volume of sales was not materially affected. Paul B. Norris, of the Wiley B. Allen Co., made some excellently good sales during the epidemic. J. H. Matney, of Meier & Frank Co., says business was never better. C. Guy Wakefield, himself a sufferer from the disease, was only absent from the store a short time, and during his absence business was normal and even better than it has been for some time before. Bush & Lane were moving during the epidemic, and Mr. Loder, in charge of the phonograph department, was ill with a slight attack of the disease for a week, but business went on as usual. The Seiberling-Lucas Co. did a fine business, and the general report is that during the epidemic business in the talking machine departments was better than ever before.

The psychological reason is easy to explain. Nothing dispels gloom like music.

WAR REVENUE BILL BEFORE SENATE

Senate Finance Committee Completes Work of Redrafting Measure—Strong Opposition Has Developed—Trade Should Be on Guard.

WASHINGTON, D. C., December 9.—The Senate Finance Committee on Friday reported the committee's draft of the New War Revenue bill which now goes to the Senate for discussion and passage. It is the general belief that the further progress of the bill will be a rather stormy one, inasmuch as great differences of opinion have developed as to its provisions.

The provisions of the bill as they affect directly the music industry are found in Section 900 under the heading of Excise Tax, and which reads in part:

That there shall be levied, assessed, collected, and paid upon the following articles sold or leased by the manufacturer, producer or importer, a tax equivalent to the following percentages of the price for which so sold and leased.

(3) pianos, organs (other than pipe organs), piano players, graphophones, phonographs, talking machines, music boxes, and records used in connection with any musical instrument, piano player, graphophone, phonograph or talking machine, five per centum.

As has been reported previously, the floor tax sections of the bill were entirely eliminated by the Senate Finance Committee, but those acquainted with the situation advise that trade members keep in close touch with the progress of the bill in order to guard against the possibility of the floor tax provisions being again inserted. Incidentally it might be well to keep an eye on the other sections of the bill to guard against any unfavorable action.

Record Delivery Envelopes
Safe - Swift - Secure

The heavy paper means protection; the button and cord mean speed — you can wait on more customers.

Bring out YOUR OWN NAME. Every time an envelope leaves your store, let the advertisement on it take your name to the homes and bring new trade. The advertising more than pays for the envelope. Write for samples and prices.

Lewis C. Frank, 694 Book Bldg., Detroit

"NICHOLSON"
New Catalog Showing New Styles
RECORD CABINETS
strictly high-grade construction at prices
BELOW COMPETITION

Write for a copy of the catalog and our special free advertising help for dealers.

K. NICHOLSON FURNITURE CO. Chase City, Virginia
Sectional Bookcases and Record Cabinets

Walter S. Gray
Chronicle Bldg., San Francisco, Cal.

NEEDLES

Pacific Coast Jobber for the Best in Talking Machine Trade Accessories



SOSS

INVISIBLE HINGES

Preserve Beauty

In many beautifully designed, finely finished Talking Machines, Pianos, Music Cabinets, Piano Players and Benches, the elimination of the unsightly protruding Hinge is essential to preserve the beauty of the design.

Design and Construction

The fine cabinet work which is required in many instances to preserve the disguise of the instrument requires that the hinges be as inconspicuous as possible. SOSS Hinges are *invisible*.

WRITE FOR CATALOGUE "T"

SOSS MANUFACTURING COMPANY, 435 Atlantic Avenue, BROOKLYN, N. Y.

DETROIT—922 David Whitney Bldg.
SAN FRANCISCO—164 Hansford Bldg.

LOS ANGELES—600 Metropolitan Bldg.
CHICAGO—John C. Bold & Co., Clark and Washington Sts., Conway Bldg.



PORTLANDERS GOOD ADVERTISERS

Most Talking Machine Dealers Firm Believers in Consistent Publicity—New Lines Enter the Field—Recent Changes Among Local Houses

PORTLAND, ORE., December 9.—Soule Bros. are advertising the Brunswick talking machine, and their advertisements are of a very attractive and interesting kind. It is noticeable that all the best and most reliable dealers of Portland advertise extensively in the local papers. G. F. Johnson advertises the Cheney in such a manner that the readers of the papers look for what he has to say and many Cheney's have been sold to people who were unacquainted with the talking machine before reading Mr. Johnson's interesting ads. Bush & Lane advertise the Sonora and have been so successful in placing the merits of this excellent machine before the Oregon public that a large number of these instruments has been sold in Portland and other towns in Oregon and the Pacific Northwest. The Wiley B. Allen Co. have always been a big advertiser. The Brunswick machine has been added to their stock and is being well advertised by the company with the usual good results. The Hovenden Co. is advertising the Stradivara, and this good talking machine is gaining the attention of buyers and sales are steadily increasing. The Gilbert Co. has very unusual advertisements. Harold C. Gilbert, manager of the company, advertises the Columbia graphophone in a very original manner. All dealers of the Columbia advertise constantly and intelligently. C. Guy Wakefield advertises the Brunswick and has made a big success of the machine, selling one carload after another. The Seiberling-Lucas Co., the Eilers Co., the Graves Music Co., the Reed-French Co. all use printer's ink to advertise their stock and all are well known reliable firms carrying good goods, which they are proud to advertise.

The Powers Furniture Store has added the Brunswick phonograph to their talking machine

department. W. B. Maxwell, manager of the department, is very well pleased with the machine and predicts big sales for the holiday trade.

The removal sale of the Bush & Lane Piano Co. was confined strictly to the piano department, the talking machine department did not participate in the removal sale. It is the policy of Bush & Lane not to accept other makes of talking machines in exchange for what they have in stock unless the instrument to be exchanged is under \$40 in price. A mistake occurred in advertisement which gave the impression that there would be an exchange in talking machines.

A fine stock of Victrolas, Columbias, Edisons, Stradivaras and Cowan Classiques can be found at Graves Music Store. The phonograph department of this store has been overhauled and is now very attractive looking. L. D. Heater, manager of the local Columbia Graphophone Co., has supplied the department with a good stock of Columbia records.

Miss Acevia Bennett, who was in charge of the record department of Eilers Music House, has just returned from San Diego, where she has been for a couple of months and is now with the Graves Music Co. on Fourth street.

The phonograph department of the Meier & Frank Co. has secured the services of Miss Olga Moreland, who has been for years with the Portland branch of the Columbia Co.

The display rooms of the Columbia Graphophone Co. are almost empty, and no machines coming this way, while the demand is unprecedented. A good supply of records is on hand though the demand for them is great.

The phonograph department of the Olds, Wortman & King department store has been discontinued.

The phonograph department of Meier & Frank Co. has done a very big business during the "flu" epidemic. The Edison phonograph is selling particularly well at this house. J. H. Matney, manager of the department, has just sold two of the higher-priced Edisons to members of the same family—mother and daughter.

Frey's Sporting Goods Store, of Baker, Ore., is extensively advertising the Brunswick, which is a prime favorite in eastern Oregon.

There is a fine supply of Pathé machines at Calef Bros. Furniture Store. One of the large show windows is filled with them. All styles are on display. Mr. Calef says business is excellent. The new Pathé records are specially good, and there is a great demand for them.

Trade is lively in the talking machine department of the Wiley B. Allen Co. The Brunswick, which has recently been added to the stock, is a notably big success.

Miss Anna Schuster and Mrs. Jordan have joined the sales force of the Hyatt Talking Machine Co. Business keeps on growing and this attractive and well-appointed store is a big factor in the talking machine trade of Oregon.

TALKING MACHINE MEN, INC., MEET

Suggestion Made That Monthly Record Releases Be Demonstrated Early Each Month—May Join Chamber of Commerce

The monthly meeting of the Talking Machine Men, Inc., the organization composed of dealers in New York, New Jersey and Connecticut, was held in the assembly rooms of the Merchants' Association, Woolworth Building, New York, on Wednesday afternoon, November 20.

M. Max, manager of Gimbel Bros. piano and talking machine departments, suggested that the organization have the large talking machine companies, including the Victor and Columbia Cos., demonstrate their monthly record releases on the first Wednesday of each month. Also that the meeting dates of the organization be changed to the first Wednesday of each month instead of the third, as at present, so as the following month's records could be heard. This idea was presented in the form of a motion and received unanimous approval.

Much consideration was given to the proposition of joining with the Music Industries Chamber of Commerce, a committee having been appointed at the previous meeting for the purpose of securing data in regard to the association's future, etc. E. G. Brown, secretary of the association, and Henry Mielke, of the legal committee, as members of the special committee appointed to inquire into the merits of joining the above body, spoke in favor of the action, and it was decided to appoint President J. T. Coughlin, Secretary Brown and Henry Mielke as a committee to follow up the matter with authority of joining the Chamber of Commerce. As usual, it was voted that the December meeting be eliminated.



Manufacturers—Jobbers—Dealers

The new PUR-I-TONE reproducer No. 8 is now ready for delivery, and we wish to say to the trade that we have in this reproducer the finest mechanism of the kind that has ever been offered by any manufacturer for sale. The volume and clarity of sound surpasses all results of the past, and surface friction is now reduced to the least possible minimum. When attached to our PERFECTION ball-bearing tone arms, and used for playing Victor and Columbia records, on ALL types of Edison Disc Machines, the reproduction of sound in general from all lateral cut records will be all that the most exacting record buyer can demand. The new PUR-I-TONE model No. 8 will also be attached to our new UNIVERSAL arm No. 6 for playing ALL makes of lateral and hill and dale records on Edison Disc machines. Do not fail to place a quantity of these new accessories in stock if you want to place the finest reproducers and tone arms manufactured in the hands of your machine customer.

Quantity price quoted on application, in gold, nickel and oxidized bronze finish.

Manufactured by

NEW ENGLAND TALKING MACHINE CO.

Largest Manufacturers of Phonograph Accessories in the World

16-18 Beach St. Boston, Mass.

See our ad on page 23

MAKE YOUR SHOW WINDOWS PAY YOUR RENT

Record Display Stands, Hold any Size Record Golden Oak or Mahogany Finish—5 Sizes

No. 341. 1 Record \$1.00 ea.	
No. 342. 2 Records \$1.25 ea.	
No. 343. 3 Records \$1.50 ea.	
No. 344. 4 Records \$1.75 ea.	
No. 345. 5 Records \$2.00 ea.	

THE OSCAR ONKEN CO.
No. 6651 4th St., Cincinnati, O.

A SMILE THAT EXTENDS FROM CHICAGO TO NEW YORK PROTEST AGAINST THE FLOOR TAX

Employees of the New York Talking Machine Co. and the Chicago Talking Machine Co. Express in No Uncertain Way Their Enthusiasm Over the Good Times Coming to the Trade

The feeling of optimism and confidence in the future that seems to be general in the talking machine industry at the present time is well exemplified in the splendid spirit shown by the New York Talking Machine Co. and the Chicago Talking Machine Co. in its publicity in *The World* this month. Arthur D. Geissler, president of these two prominent Victor wholesalers, has always been a firm believer in the idea of looking on the bright side of things, and even though the Victor industry has faced unprecedented conditions the past year and the wholesalers have been obliged to solve unusual problems, Mr. Geissler has never lost his faith in the industry and in the future, and he has installed this same spirit in the hearts of all of his co-workers in New York and Chicago.

Every employe of the New York Talking Machine Co. and the Chicago Talking Machine Co. has been instructed by Mr. Geissler to "smile," and they have followed out his instructions to the letter, with the result that there is a feeling of good cheer in both of these organizations that reflects the spirit of the Victor industry as a whole. It might be suspected, however, that the "smiles" of some of the executives are just a little forced—but at the same time the trade at least cannot help but smile with these companies. We do not know just how to interpret the general smiles of the New York and Chicago Talking Machine Co.'s employes, whether it is in anticipation of goods to come, and business better than ever, or a welcome smile to those employes about to return.

The Victor industry and the wholesalers in particular can well be proud of its record during wartimes, for the various firms and their employes have contributed more than their share to the many patriotic and financial movements sponsored during the past eighteen

months. They have subscribed liberally to the Liberty Loans, War Savings Stamps campaigns, and the different other funds, and in addition a full quota of talking machine men enlisted under Uncle Sam's banners to fight for democracy.

The New York Talking Machine Co. and the Chicago Talking Machine Co. are deserving of the unlimited commendation of the trade for the spirit in which their "boys" enlisted in the army and navy as soon as the United States entered the war. The service flag for these two companies contains no less than fifty stars, and a royal welcome is being planned for these boys in addition to the practical welcome of their old jobs back as soon as they are ready to resume activities in civilian life.

MISS WENDT WEDS MILLIONAIRE

Daughter of Brooklyn Talking Machine Dealer
Bride of Jesse L. Livermore

Miss Dorothy Fox Wendt, daughter of Louis A. Wendt, well-known talking machine dealer, 566 Nostrand avenue, Brooklyn, was married on December 3 to Jesse L. Livermore, known in financial circles throughout the country as "the boy plunger," and whose operations in the stock market are declared to have made for him a fortune of at least \$10,000,000. The wedding took place at the St. Regis Hotel. Mr. and Mrs. Livermore are spending their honeymoon at Atlantic City. The wedding was strongly featured on the front page of the New York newspapers.

L. A. Oakley has been appointed manager of the talking machine department of the Leader Store, Baltimore, Md., where the Columbia line is handled.

J. N. Blackman and L. F. Geissler Both Urge Members of Industry to Protest Against That Provision of War Revenue Bill—Floor Tax Eliminated From Latest Draft of Measure

Several weeks ago while the War Revenue bill was still in the hands of the Senate Finance Committee J. Newcomb Blackman, president of the National Association of Talking Machine Jobbers, sent to the members of the committee a strong letter of protest against Sections 909 and 910 of the bill as it left the House, which sections provided for the collection of a floor tax on all musical instruments, covered by the bill, in the hands of manufacturers, wholesalers or retailers when the bill became a law. Mr. Blackman made the point in his letter that the Jobbers' Association, through its membership, represented fully 20,000 talking machine dealers in the country.

At the time the letter was sent Mr. Blackman urged all members of the association, as individuals, to protest against the floor tax to their Senators and Congressmen.

Under date of December 5 Louis F. Geissler, general manager of the Victor Talking Machine Co., sent a circular letter to the trade urging that wholesalers and retailers protest to their Senators and Congressmen against the sales tax covered by Section 900, and the floor tax covered by Sections 909 and 910 of the pending War Revenue bill.

Since Mr. Blackman and Mr. Geissler sent their letters the War Revenue bill has been reported out of the Senate Finance Committee, and is now in the hands of the Senate, as stated elsewhere in *The World*, and in the bill in its present form it is found that Sections 909 and 910, providing for the floor tax, have been entirely eliminated.

It is urged, however, that the members of the trade continue to watch the bill closely in order to protect their interests.

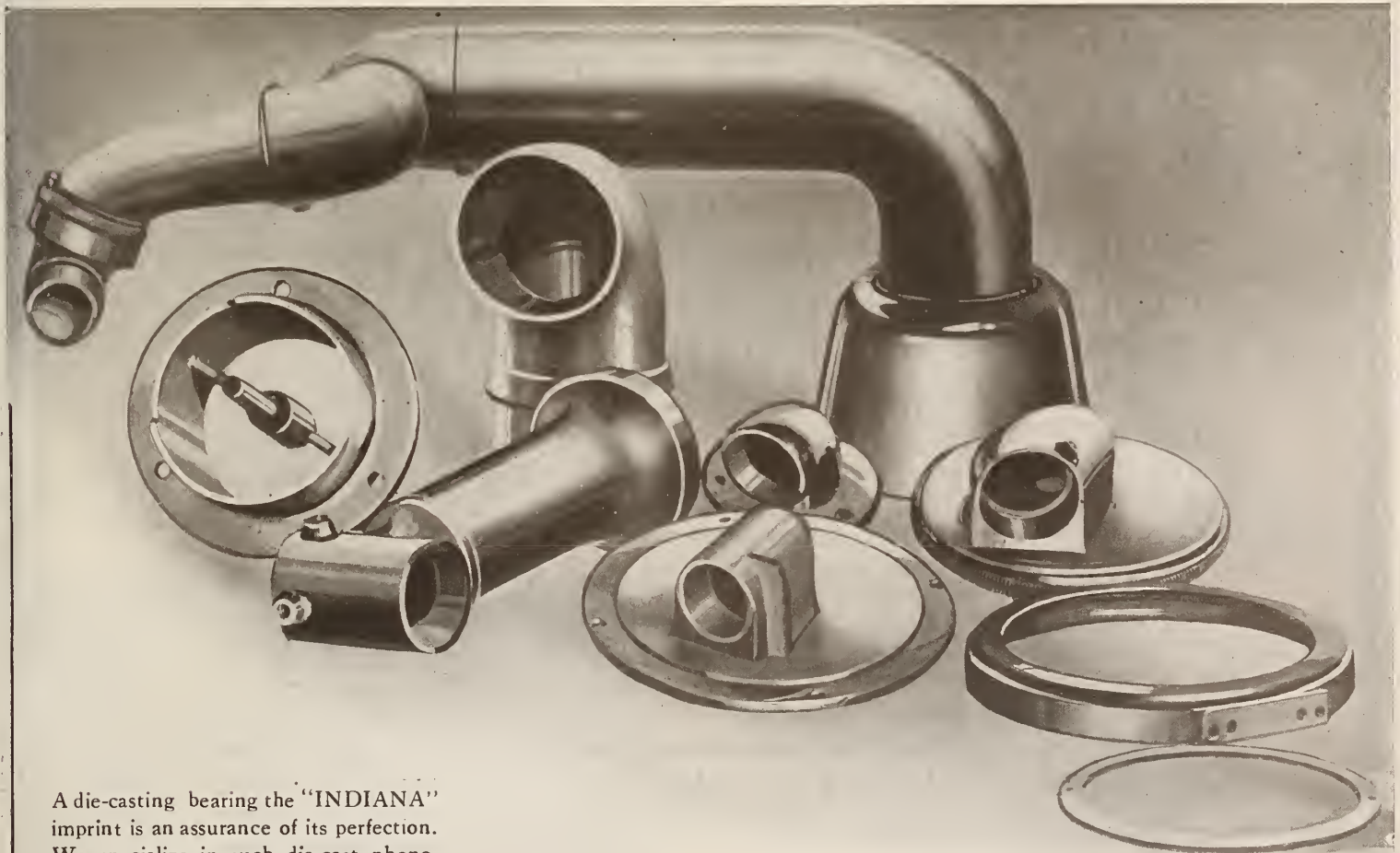

A die-casting bearing the "INDIANA" imprint is an assurance of its perfection. We specialize in such die-cast phonograph parts as shown above.

"INDIANA" DIE CASTING CO.

CORNELL AVE., at 11th ST.

INDIANAPOLIS, IND.



ANOTHER YEAR HAS ROLLED AROUND AND ANOTHER CHRISTMAS IS HERE. THERE ARE MANY MESSAGES I MIGHT SEND TO YOU BUT THE BEST WOULD FAIL TO EXPRESS THE MESSAGE WHICH IS IN MY HEART. AND SO, ON THIS CHRISTMAS DAY, I'LL JUST STRETCH MY HAND ACROSS THE MILES BETWEEN US, AND I'LL TAKE YOURS, AND I'LL SAY "MERRY CHRISTMAS TO YOU AND MAY THIS COMING YEAR BRING YOU MUCH OF LOVE AND MUCH OF WORK."

CORDIALLY YOURS,

Frank V. Nutze

VICE-PRESIDENT

STEPHENSON, INC., *1 West 34th Street, New York*
MAKERS *of the* STEPHENSON PRECISION MADE MOTOR

ATTENTION, DEALERS!!

If you are looking for quick service and the right prices, get in touch with us on the following lines:

STANDARD MUSIC ROLLS,
Perfection, Sing-A-Word, and Arto.
Complete line always on hand.

EMERSON 7-inch Disc Records
WALL KANE NEEDLES

Write for catalogues and prices

ENTERPRISE MUSIC SUPPLY CO., 145 West 45th Street, New York City

We are the largest jobbers of sheet music and music books in the U. S. Write for our monthly bulletin

We Wish Everybody A Merry Christmas and A Happy New Year

BUSINESS HARVEST IN BALTIMORE

Stock Situation Improving and Talking Machine Dealers Report Steadily Growing Volume of Sales—Liberal Advertising the Rule

BALTIMORE, Md., December 7.—This is the month of harvest for the talking machine dealers, and already there are signs on every hand that it is going to bring forth results that will please most of the dealers and jobbers. Of course, a great deal more money could be made by the jobbers and some of the retailers if there were more machines to be had in certain lines. While machines are lacking in these two lines the supply of records to date, if kept up, will make up in a large measure for the shortage of machines.

Advertising has been liberal on the part of the dealers. There were some very attractive Aeolian-Vocalion ads run in the newspapers by the Sanders & Stayman Co., the local representatives of the machine. Sonora came in for more advertising recently in Baltimore than for a long time, and this is no doubt due to the fact that the machine is being more generally placed about, the music department of The Hub and the Mann Piano Co being the latest firms to add that line to their others. The Hub now handles three lines, Victor, Columbia and Sonora.

Business with the Columbia branch here showed up well considering the fact that the branch was without any machines worth speaking of, except period models. These period models have been selling very well, according to William S. Parks, the local manager.

While the shortage of machines is just now as it has been for some time, Mr. Parks expects the situation to improve before the close of the month. To take care of the Christmas business Mr. Parks had a canvass made of all of his dealers and managed to obtain machines from some firms who believed they had more than they could handle and transfer them to less fortunate ones.

A big shipment of records arrived the first

of the month, and the force worked night and day to get them out to the trade. Mr. Parks spent several days in Richmond during the month. Harry B. Goodwin, chief of the educational department of the Columbia Co., spent some time in Baltimore and visited many educational institutions. His trip brought some good results to the dealers. F. K. Pennington, assistant general sales manager; O. F. Benz, of the general sales manager's office, and R. F. Bolton, of the international record department, all from the Columbia headquarters, held a sales meeting in Baltimore during the month.

W. C. Roberts, manager of E. F. Droop & Son Co., Victor distributors, reports a 25 per cent. increase in business in November. Mr. Roberts was one of the fortunate jobbers who happened to have a liberal supply of the small machines and they helped to bring up business for the month. The arrival of a liberal shipment of records also helped with the business.

Jesse Rosenstein, for the National Piano Co., Pathé distributors, reports an active degree of business. There has been a fair shipment of goods to this concern during the month, and he is hoping for another good shipment.

Miss Elizabeth Sterns has been placed in charge of the Victrola department of the Maryland Piano Co., and the business is showing very fine improvement.

E. J. Dingley, sales manager of the Victor Co., was in Baltimore during the month and visited the dealers and jobbers.

Baltimore was the haven for Southern buyers, especially from North Carolina and Virginia all looking for goods. Most of them sought to convince all of the jobbers that they should have preference over the other fellow when it came to a question of obtaining goods.

George D. Noonan, who recently came from Brooklyn, N. Y., to assume the management of the Victor department of the Anthony Furniture Co., Providence, R. I., is now confined to his home as a result of a nervous breakdown.

COURT DECISION IN RECORD SUIT

U. S. District Court in Action of American Graphophone Co. vs. Emerson Phonograph Co., and Victor H. Emerson Finds That Defendants Did Not Infringe Jones Patent

A decision was handed down December 9 by Judge Meyer in the United States District Court of New York in the suit of the American Graphophone Co. vs. the Emerson Phonograph Co. and Victor H. Emerson, in which the court finds that the Emerson Co. has not infringed the Jones Patent No. 688,739 in making the so-called Emerson universal cut groove record.

In his opinion Judge Meyer goes into the entire history of record manufacturing, and referring to the claim of the plaintiff that the vertical undulations in the Emerson record are inert and do not perform any useful function states as follows:

"The vertical or hill and dale undulations of Emerson are therefore real and do perform an active and useful function. Whether this conclusion is correct or not, it is at least apparent that the burden of proving the infringement has not been sustained by plaintiff."

In closing Judge Meyer says: "Finally, it is an important, outstanding and emphatic fact in this case that, whether well or badly done, the Emerson record may be played on either a hill and dale or zigzag type of phonograph—a result which was never before commercially attempted. The bill is dismissed with costs."

In the course of his opinion Judge Meyer also finds occasion to state that "so far as this record disclosed Emerson was not guilty of any wrongful or improper act. He availed himself of existing knowledge open to all the world and endeavored to devise a process different from that of the patent in suit. This he was fully entitled to do."

Ernest Damon has joined the sales staff of the talking machine department of the Shepard Co., Providence, R. I.



ED. USOSKIN, Inc.

VICTOR RECORD DISPLAY CARDS

The authorized monthly sign service that is in keeping with the high quality of Victor merchandise.

24 Beautiful Show Cards ONLY \$3.00 Per Month

Sold Exclusively Through Victor Jobbers

Imitation Records and Fancy Papers for Window Trimming Purposes.

ED. USOSKIN, Inc., 230 W. 17th St., NEW YORK

JOY REIGNS IN LOS ANGELES WITH HANDICAPS REMOVED

Coming of Peace and Lifting of "Flu" Ban Cause Talking Machine Dealers to Go After Business With Renewed Energy—Shortage of Goods Passing the Acute Stage

LOS ANGELES, CAL., December 4.—Joy reigns supreme in Los Angeles as the "flu" ban is to be lifted at twelve o'clock and the "lid" will be removed from all public gatherings.

In spite of this apparent handicap the talking machine business has kept up and everybody in that line has been kept busy.

The opening of the Liberty Fair, which has been postponed from time to time since October 26, has finally been officially set for today.

The shortage on machines has passed the acute stage and now conditions are getting desperate. Many models are getting scarce and in fact some are entirely out at this time.

The exchange system originated by the local talking machine association seems to have worked out to the benefit of all.

Herman Beck, manager of the talking machine department for the George J. Birkel Co., reports the best November business in the history of the house and looks for another record-breaking month in December if his machine stock will only hold out.

C. S. Ruggles, local manager for Sherman, Clay & Co., has been on the sick list for the last two or three weeks.

The Burnham Phonograph Co., located at Nineteenth and Los Angeles streets, are doing a rushing business at present and Mr. Burn-

ham, the president of the company, says he has had to put on extra help to catch up with his back orders.

Owing to the large number of tourists in the city at present there has been quite a demand for rental machines.

B. S. Pittenger, who has been on the outside for the last three years for the Southern California Music Co., has accepted a position with them as floor salesman in the talking machine department.

Harold Jackson, manager for the Wiley B. Allen Co., had a very unique window display last week.

COMMERCIAL FAILURES CUT

Fewer Insolvencies Reported Than in Any Month Since 1894

A continued decrease in the number of commercial failures in the United States is shown in the report of R. G. Dun & Co. for the month of November, when the total was only 570.

These figures compare with 660 insolvencies for \$13,980,306 in October of this year, 981 for \$13,635,605 in November, 1917, and with 1,815 reverses for \$25,489,458 in November, 1914—the high point for the period.

November, 1914, which reflected the dislocation of trade and industry caused by the outbreak of the war several months earlier, is 68.6 per cent. More than this, the November liabilities, although somewhat larger than those of November, 1917, are smaller than in October and September of this year, and are also less than in any November, with the exception noted, back to 1910.

Over 10,000 talking machine records were collected in one week recently by the Providence Journal, Providence, R. I.

Walter R. Finigan, formerly manager of the Victor department of the Stewart Drygoods Co., Louisville, Ky., is now in France with the American Expeditionary Forces.

START

Send a trial order for GLO-RITE PIANO CREAM to your jobber, so you will have the goods to begin THE NEW YEAR

Don't Neglect the Profit Longer

The ONE and Only POLISH CLEANER and REVIVER for the Musical Inst. trade in a CREAM form and packed in tubes.

ALL QUALITY Not Quantity

"Not a Floor Oil"

PACKED IN 15c., 30c., 50c. Tubes also Larger Packages



Every Package Guaranteed to Give Satisfaction

LIMITED FREE OFFER

Should You Desire Sample, Communicate With MASTER MFG. & SPECIALTY CO. CAMDEN, N. J.

Special Representative—Clement Beecroft

NOTE.—No samples sent unless name of jobber you deal with accompanies the request.



RECORD CABINETS

Advertisement for record cabinets including a list of 30 records and a diagram of a cabinet.

Record Envelopes

All kinds

Write for prices

CLEMENT BEECROFT

309 West Susquehanna Avenue PHILADELPHIA, PA.

BUEHN MEN MAKE GOOD IN SERVICE

Ensigns Bliss and Callahan Show the Results of the Buehn System of Efficient Training in Their Progress as Naval Officers

PHILADELPHIA, PA., December 7.—In the window of the Louis Buehn Co., this city, hangs a big Liberty Loan honor flag. Over Mr. Buehn's desk is a small silk service flag. Thereby hangs a tale.

Buehn is a tireless worker. He is as big in his energies and ambitions as he is in physique. At the outbreak of the war the first problem that presented itself to him was the extent to which he could sacrifice the services of those who had been instrumental in bringing the slogan "Buehn for Bigger Business" before the Victor trade. His was a small, hard-working organization and he could not well afford to sacrifice any of his men.

But within a few weeks he had given his two senior salesmen—Lucien D. Callahan and E. P. Bliss, Jr.—to the service. Both young men are now officers in the U. S. Navy. Then followed others, like popular young "Bob" Carpenter of the sales force, now with a machine-gun division in France; and Raymond Boldt, with the Army motor-transportation service; and record-clerks and shippers released for various duties.

It has been difficult to get along without these men and yet Buehn has been cheerful and optimistic through it all, and the occasions have not been infrequent when the vice-president of the company and even Buehn himself have peeled off their coats and dug into the shipping room.

With the constantly decreasing output of the Victor factory the sales of a month with Buehn began to look worse than the pre-war sales for a week. But Buehn did not grumble nor pester the Victor factory. Grumbling wouldn't win the war. So he took hold of the Liberty Loan work; the War Savings Stamp campaign; the Y. M. C. A., Red Cross, and War Chest drives. He worked tirelessly—in the downtown district

by day and in the suburbs at night. His family sacrificed and practiced rigid economy.

One of the results is the honor flag in the window, presented to Buehn for the greatest amount of subscriptions to the Liberty Loan in his downtown district. Just two or three weeks ago he was co-operating with the Penn Phonograph Co., H. A. Weymann & Sons, and the other Philadelphia jobbers in a campaign to help raise a million used records for the boys at sea and in the camps and hospitals.

Further credit has been reflected upon



Ensign
E. P. Bliss, Jr.



Ensign
L. D. Callahan

Buehn's leadership by the success of his men in the service. Take, for instance, Bliss and Callahan. Both men enlisted shortly after the declaration of war. All they ever knew about navigating was confined to manipulating a sputtering motor-boat or tipsy cat-boat along the Jersey coast. But they applied themselves diligently to their studies and in a few months passed their exams and won the coveted "anchors" of an ensign, a rank usually conferred only after four years at Annapolis. To-day Ensign Callahan is communication officer of the Fourth Naval District at the headquarters of Admiral Helm, and Ensign Bliss is communication officer at Bordeaux, France. Mr. Bliss formerly traveled for Lyon & Healy, Chicago, and Mr. Callahan traveled the Pacific Coast and Western States for the Victor Co.

It is leadership like this of "Lou" Buehn that

inspires big things—optimism, pep, ambition—and it is this spirit that has made America the winning factor in the war. And that spirit, with patience and faith, brings loyal dealers and ultimate success.

NOW COMES THE "LAMPOGRAPH"

Invention of F. H. Feraud of Considerable Interest and Originality

F. H. Feraud, of Granite City, Ill., is the latest inventor to offer something new for the consideration of the talking machine dealer and would-be talking machine owner, in what he calls the "Lampograph," which combines a lamp and a phonograph in a rather novel manner. There have, of course, been phonographs installed in lamps before this, but Mr. Feraud has incorporated a number of new features in the matter of sound control and other particulars, which add to the interest of his product. Instead of having the sound come direct from the lamp shade, using an amplifying horn, Mr. Feraud's device is designed to throw the sound downward against the table upon which the lamp stands, from which it is reflected and thrown into the room. The "Lampograph" is particularly designed for use as an art object, when set with precious and semi-precious stones and otherwise embellished. Several models have been perfected.

RETURNS TO CIVILIAN LIFE

Talking machine dealers in metropolitan territory will be glad to learn that Leon Tobias, formerly traveling representative for Arthur L. Van Veen & Co., and more recently a member of Uncle Sam's navy, has returned to civilian life and will resume his former duties next week. Mr. Tobias achieved signal success in the introduction of the Van Veen bedset system among dealers in this territory, and his many friends in the trade will undoubtedly extend him a cordial welcome upon his return from the navy.

"Dayton" Motor No. 31

Recommended for all high-grade Phonographs

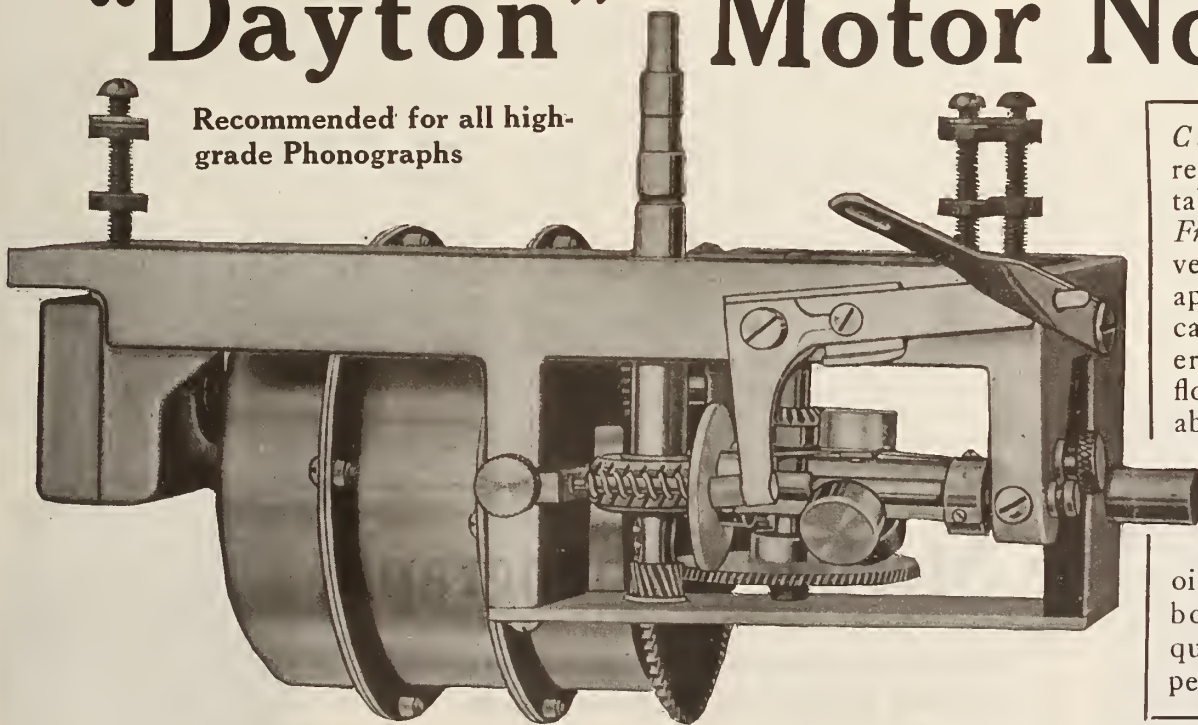

Capacity over 1500 revolutions of the turn table to one winding. Frame finished in silver bronze. Easily applied to any form of cabinet. Springs powerful, triple, vertical, floating. Easily removable. Turn table drive shaft, high quality steel, especially tempered shaft, running in self-oiling bearings. Embodies the highest quality of mechanical perfection.

DAYTON MOTORS

Possess all the sterling qualities that go to build up a successful phonograph business. They are sold to builders of all high-grade talking machines—and give universal satisfaction to the user. Made of the finest grade of material by skilled workmen. Run without vibration, give long service and build permanent business.

Build satisfaction into your product by using the Quality Line. Dayton Motors, Dayton Tone Arms, Dayton Reproducers. It will bring you more business and satisfy the most exacting customers.

Write for full particulars



THE THOMAS MFG. CO., 322 Bolt St., Dayton, Ohio
CHICAGO OFFICE, 1500 REPUBLIC BLDG.



THE FISCHER CO.



Pathe Phonographs and Records

The Merriest of Merry Christmases
The Happiest of All New Years
To the Trade



THE FISCHER CO.

OLDEST PATHE JOBBERS

940-1030 CHESTNUT AVE., CLEVELAND, OHIO



EMPIRE BUSINESS ON INCREASE

Factory Working Overtime to Meet Demands—
Excellent Results Obtained by Trade Representatives Recently Appointed by Company

CHICAGO, ILL., December 7.—At the factory of the Empire Talking Machine Co. it was stated that the demand for machines and records made by that company was of unprecedented volume, and that in order to keep in sight of orders it was necessary to operate the production, shipping and other departments of the factory overtime. Letters are being received from Empire dealers in various sections of the country telling of their success in selling the line; how the machines and records pleased the customers, and in themselves influenced other sales.

A. R. Mitchell, of Williamsport, Pa., has been spending a few days in the local factory looking after shipments to his customers, and will visit the factory of the Empire Phono Parts Co. in Cleveland on his way home to look over that plant and its facilities for turning out the equipment used in Empire machines. Mr. Mitchell has been very successful in placing the Empire agency with prominent music and furniture houses in Pennsylvania.

The Empire Talking Machine Co. has recently engaged R. N. Oates, of New Albany, Ind., to represent them in the States of Indiana, Illinois, Kentucky and Tennessee, and Mr. Oates

has opened up some very fine accounts in the few weeks he has been on the road.

That there is a large demand for high-class phonographs in the South is evidenced by the orders that are reaching the factory from J. H. Stiff, who only recently started to cover the Southeastern States for the Empire line. Both Mr. Stiff and Mr. Oates have been connected with the piano business for many years, and enjoy the confidence of the trade they serve to the fullest extent.

EASTERN DEPARTMENTS DIVIDED

BOSTON, MASS., December 11.—Plans which have been announced for the separation of the wholesale and retail departments of the Eastern Talking Machine Co., Victor distributors, are rapidly becoming realities, and it is expected on December 15 the wholesale department will be removed to the building on Oxford street which the Eastern Talking Machine Co. have used for the storage of their Victor goods. Manager Fitzgerald and Chas. Urlass, assistant manager, will occupy general offices on the third floor of this building, which are rapidly nearing completion. The entire building has been thoroughly renovated and will provide exceptional facilities for their wholesale business.

The retail business will remain at the present Tremont street address, the location being most desirable.

COLUMBIA ANNUAL CONVENTION

Annual Gathering of Branch Managers to Be Held January 6, 7, 8 and 9 at Hotel McAlpin, New York—Elaborate Entertainment Planned

The general sales department of the Columbia Graphophone Co. announced this week that the annual convention of Columbia branch managers will be held on January 6, 7, 8 and 9 at the Hotel McAlpin. George W. Hopkins, general sales manager of the company, will preside at this conference, which will be given over to the discussion of important problems bearing on the reconstruction period that the country now faces. It is planned to have the conventions of the Grafonola and Dictaphone branch managers take place simultaneously, and, although there will be the usual banquet, theatre party, trip to the factory, etc., this meeting promises to be noteworthy for the practical value of the program which is now being prepared.

STATEMENT OF THE OWNERSHIP, MANAGEMENT, CIRCULATION, ETC., REQUIRED BY THE ACT OF CONGRESS OF AUGUST 24, 1912,

Of The Talking Machine World, published monthly at New York, N. Y., for October 1, 1918.
STATE OF NEW YORK,
COUNTY OF NEW YORK, ss.

Before me, a Notary Public, in and for the State and county aforesaid, personally appeared J. B. Spillane, who, having been duly sworn according to law, deposes and says that he is the Editor of The Talking Machine World, and that the following is, to the best of his knowledge and belief, a true statement of the ownership, management (and if a daily paper, the circulation), etc., of the aforesaid publication for the date shown in the above caption, required by the Act of August 24, 1912, embodied in section 443, Postal Laws and Regulations, printed on the reverse of this form, to wit:

1. That the names and addresses of the publisher, editor, managing editor, and business managers are:
Publisher—Edward Lyman Bill, Inc., 373 Fourth avenue, New York City.
Editor—J. B. Spillane, 373 Fourth avenue, New York City.
Managing Editor—J. B. Spillane, 373 Fourth avenue, New York City.
Associate Editor—J. Raymond Bill, 373 Fourth avenue, New York City.
Business Manager—None.

2. That the owners are: (Give names and addresses of individual owners, or, if a corporation, give its name and the names and addresses of stockholders owning or holding 1 per cent or more of the total amount of stock): Edward Lyman Bill, Inc., 373 Fourth avenue, New York City; Caroline L. Bill, New Rochelle, N. Y.; J. B. Spillane, 373 Fourth avenue, New York City; J. Raymond Bill, 373 Fourth avenue, New York City; Estate of August J. Timpe, 164 Fifteenth street, West New York, N. J.; B. B. Wilson, 373 Fourth avenue, New York City; Carleton Cbace, 373 Fourth avenue, New York City; L. M. Robinson, 373 Fourth avenue, New York City; E. P. Van Harlingen, 209 South State street, Chicago, Ill.

3. That the known bondholders, mortgagees, and other security holders owning or holding 1 per cent or more of total amount of bonds, mortgages, or other securities are: (If there are none, so state.) None.

4. That the two paragraphs next above, giving the names of the owners, stockholders, and security holders, if any, contain not only the list of stockholders and security holders as they appear upon the books of the company but also, in cases where the stockholder or security holder appears upon the books of the company as trustee or in any other fiduciary relation, the name of the person or corporation for whom such trustee is acting, is given; also that the said two paragraphs contain statements embracing affiant's full knowledge and belief as to the circumstances and conditions under which stockholders and security holders who do not appear upon the books of the company as trustees, bond stock and securities in a capacity other than that of a bona fide owner; and this affiant has no reason to believe that any other person, association, or corporation has any interest direct or indirect in the said stock, bonds, or other securities than as so stated by him.

5. That the average number of copies of each issue of this publication sold or distributed, through the mails or otherwise, to paid subscribers during the six months preceding the date shown above is, (This information is required from daily publications only.)

J. B. SPILLANE, Editor.
Sworn to and subscribed before me this 30th day of September, 1918. (Seal) EUGENE R. FALCK,
Notary Public, No. 6,
New York City.

(My commission expires March 30, 1920.)

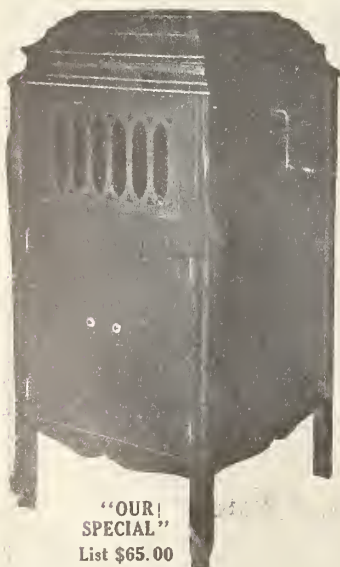

"OUR SPECIAL"
List \$65.00

The Sterling Phonograph

Most attractive offer to live dealers
9 Models, Retail from \$65.00 to \$250.00

The Supreme Phonograph

For particulars write to

The Compacto Phonograph Corporation

31 East 12th Street

New York



STYLE "C"
List \$135.00

GOVERNMENT LIFTS ALL RESTRICTIONS ON THE PRODUCTION OF TALKING MACHINES

Industry Now Free to Increase Output to Full Capacity of Factories and to Return to a Normal Business Basis—Announcement From Washington Gratefully Received

The welcome news was received from Washington on Tuesday of this week that all restrictions covering the production of talking machines and the use of metals and other materials for that purpose had been lifted, and that so far as Federal control is concerned the industry could go along under normal conditions.

The information was received by J. Schechter, secretary of the War Service Committee of the Talking Machine Industry, who said to The World: "This raising of all restrictions against the industry is the final step in placing the talking machine industry in a position to secure the full fruits of their work that the future appears to hold. The industry is now free to go ahead as in normal times, and to take care of the tremendous volume of business already booked and that which promises for the future. The Government has been very fair with the industry throughout the war period, and the lifting of curtailments at this time indicates that

the authorities want to see the industry back on a peace basis with as little delay as possible.

Immediately upon receiving word from Washington Mr. Schechter sent a letter to the members of the talking machine industry in which he said:

"It gives me great pleasure to quote below letter just received from Edwin P. Parker, Priorities Commissioner of the United States War Industries Board, advising that all restrictions affecting the talking machine industry are canceled.

"The letter reads as follows:

"Effective December 1, 1918, all restrictions promulgated by the Priorities Division of the War Industries Board affecting the talking machine industry are hereby canceled, and all pledges heretofore made and executed by any member of said industry are hereby revoked.

"Please notify each member of the industry and acknowledge receipt of this notice to me."

Rose, his assistant, are enthusiastic regarding the new recording department, which they state meets all necessary requirements, both musically and scientifically.

The city sales department of the Pathé Frères Co. distributes Pathé products to the metropolitan trade, and this branch of the business has grown so rapidly that this department was badly cramped in its old quarters at Thirty-eighth street, and additional space was found to be imperative. Mr. Valliere, who is assisted by a corps of competent salesmen, is planning to give the dealers in his territory maximum service in handling Pathé products, and the city sales department's new home will be at the disposal of Pathé dealers, who will be afforded every convenience when visiting New York.

LOCAL STORES IN NEW MERGER

Gotham Shops, Inc., Secure Interest in Business of I. Zion, Inc.—Both Stores to Be Continued at Their Present Addresses

The Gotham Shops, Inc., who handle the Columbia line at 49 Nassau street, and of which Irwin Kurtz is president, has secured an interest in the retail Victor business of I. Zion, Inc., at 2300 Broadway, but both the Gotham Shops and the Zion store will continue to operate under the present names. Mr. Zion will continue as president of I. Zion, Inc., and the store will be under the management of Maxwell Friedman, who has been elected treasurer of the company. Mr. Kurtz has assumed the office of vice-president and secretary. A camera and photographic department will be added to the Zion store.

The Litscher Lite Corp. has been incorporated under the laws of Delaware with capital stock of \$500,000 to manufacture electric light equipment and accessories. The incorporators are William Drueke, W. R. Patterson, and others, of Grand Rapids, Mich.

The Robert L. Loud Music Co., Buffalo, N. Y., has been incorporated with capital stock of \$100,000 by R. L. Loud, A. J. Boland and R. W. Werner.

SHELTON ELECTRIC PHONOGRAPH MOTOR

We have increased our factory facilities to handle the demand for the Shelton Electric Motor, and are now ready to make prompt deliveries.

Write for our Special Agency Proposition

SHELTON ELECTRIC CO.
30 East 42nd Street, NEW YORK

FINE OUTLOOK IN INDIANAPOLIS

Ben L. Brown, Manager of the Local Columbia Branch, Makes Good Report

INDIANAPOLIS, IND., December 7.—Ben L. Brown, manager of the local branch of the Columbia Graphophone Co., is enthusiastic regarding the outlook in this territory, and declares that prospects were never better than now.

"There will naturally be a slight reaction for a matter of thirty or sixty days, until the factories that have been making munitions can readjust their plants and get a start towards the manufacture of their regular line," he says, "but I doubt very much there being any noticeable let-up in the talking machine business, inasmuch as we have not been able to supply the demand for many months because of shortage of product.

"Dealers generally do not seem inclined to cancel orders they have for machines, some of these orders dating back to the early summer, which leads me to believe they are looking forward to, and expect more business than they have ever had."

Important Notice to Dealers

Why Every Dealer Should Handle The Highest Grade Phonograph Steel Needle in the World.

The WALL-KANE

First—Each WALL-KANE needle is guaranteed to play 10 records on any Phonograph, the tenth playing as clear as the first.

Second—Phonograph owners will always purchase WALL-KANE needles, since they eliminate the troublesome changing of needles after each record.

Third—WALL-KANE needles are scientifically prepared, and, by reason of special composition, are beneficial to the grooves of the record, thereby adding to its life.

Fourth—WALL-KANE needles minimize the usual scratching sound of the ordinary steel needle and greatly improve the clearness and tone of reproduction.

TEST PROPOSED TO DEALERS TO PROVE THE SUPERIORITY OF

Wall-Kane Steel Needles

Take two standard disc records of the same selection, play one ten times with the same WALL-KANE loud needle; play the other record, the same selection, ten times, but with ten new, full-tone steel needles.

You will find that the record played ten times with the same WALL-KANE needle will sound clearer, will have less surface noise, and that under the magnifying glass the grooves of the record played ten times with the ten steel needles will seem to be more disturbed.

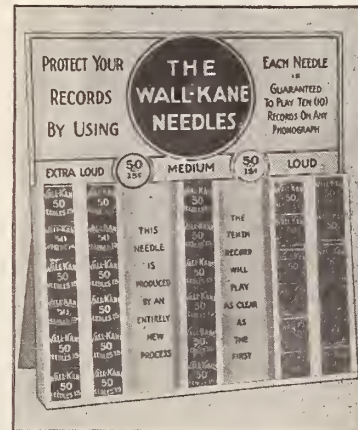

BEWARE OF IMITATIONS

Package of 50 WALL-KANE needles, Loud, Extra Loud and Medium, greater value than 500 ordinary steel needles, retails for 15c, cost the dealer 9½c.

JOBGING TERRITORIES OPEN

Progressive Phonographic Supply Co.
145 West 45th Street, New York

OCCUPYING NEW SALES QUARTERS

Pathé Frères Phonograph Co. Remove Their City Sales Offices to the Hallet & Davis Building, 1 West Forty-second Street, New York

The city sales department and the recording department of the Pathé Frères Phonograph Co. have been removed from 29 West Thirty-eighth street to the Hallet & Davis Building, 18 East Forty-second street, New York. In its new home the company is occupying two complete floors, one of which is given over entirely to the city sales division, which is under the direction of O. J. Valliere, and the other to recording purposes exclusively.

This new home of the Pathé Frères Phonograph Co. in New York is located only a few doors east of Fifth avenue, and is ideally situated from a transit standpoint. The building is a new one, and according to Russell Hunting, recording director of the Pathé Frères Phonograph Co., the fourth floor, which is occupied by the recording department, is acoustically perfect. W. H. Penn, general manager of the Pathé Frères recording laboratories, and W. H.

Dealers—Watch This Special Offer

FOR A SHORT TIME ONLY



Best quality American Steel Needles. The famous Truetone brand, packed 200 in a metal box at 65c per thousand, in any quantity. Cash with order. Order today, as offer is good only until January 15, 1919.

Maestrola Mahogany Cabinet Machines, Size 15x15x7½

Motor worm gear plays 2½ to 3 ten inch records, one winding. Prices \$4.50 in 100 lots, in dozen lots \$5.00 each, sample machine \$5.50. Cash with order

FULTON TALKING MACHINE CO.
640 Broadway New York, N. Y.

STEEL NEEDLES—U. S. MADE

NEEDLES B NEEDLES
BESTONE
FOR USE ON ALL
DISC ONE MACHINES

MADE IN U. S. A.

PROGRESSIVE PHONOGRAPHIC SUPPLY CO., 145 West 45th St., New York

Highest Grade Manufactured. Packed 100
in an Envelope. Medium, Loud, Extra Loud

75c. per thousand
60c. per thousand in quantities

Immediate Deliveries in All Quantities

HANDLING AN UNDECIDED CUSTOMER

Some Excellent and Timely Advice Regarding
the Best Means of Selling to the Customer
Who Has Difficulty in Making a Final Selection
Offered in the Interesting Story Below

Some excellent and timely advice to the salesman on the handling of the undecided customer is offered in "The Voice of the Victor" for November. Just now salesmanship is of such great value that the advice is well worth studying with profit.

In the good old days, when you and a lot of other fellows went swimming, you will remember the fellow who stood shivering on the bank until some one shoved him in. He wanted that swim as badly as the rest of you, but couldn't decide to take the first plunge. And that's the way he goes through life; never acting on his own initiative—even when buying a Victrola—but always waiting for some one else to make the decision for him.

Physiognomists—those scientists who classify different types by their features—tell us that this sort of person bears the earmarks of the indecisive type. Close scrutiny, they claim, will generally show him to have flat brows and a long, narrow and weak chin. His head is apt

to be very narrow above and behind the ears and rather square in back, and their observations show that such people are generally dark complexioned and have small snub noses.

Maybe, maybe not, but if an approaching customer bears some of these marks and, when confronted by you, looks up in a timid, apprehensive sort of way and says: "I'm just looking"—it's safe to assume that he lacks initiative. Arrived at this conclusion it's up to you to make him decide then and there. For, left to decide for themselves, such people will generally leave you at the end of an hour with a smile and an "I'll come in again."

Big things always stagger this type of individual, so avoid the momentous question of buying the article, and don't mention the price of it. If you are trying to sell him a Victrola, sidetrack the main issue and interest him in records. Find out, if possible, his business—where he lives, what his favorite pastime is and whether or not he has children. Then select the type Victrola you think he can afford and sell the instrument to him piece by piece. Show him such things as the automatic stop, the flexible tone arm, the record filing system, and even tell him the best needle to use with each record you play for him. Be sure to lay aside all the records he professes a liking for.

Paint a picture of the Victrola in the home, dwelling on the enjoyment it will bring to his family and his friends. For the indecisive man is an idealist. Therefore, he is more liable to decide to buy a Victrola if he believes that he is doing some one else a service than he is if you merely tell him of the pleasure he will derive from his purchase. In a casual sort of way ascertain on what terms he would like to buy and how soon he would like the Victrola delivered if he should buy it. Then give him the final shove.

Hand him your pen and show him where to sign the contract—which you have already filled out as far as possible.

Tactfully, but forcefully, make him realize that he is not buying a Victrola for his own entertainment as much as he is for the entertainment and education of his family and their friends. Show him that he is taking advantage of your position if he doesn't buy after allowing you to spend so much of your time demonstrating the Victrola and playing records for him. Make it plain to him that it was only natural for you to conclude that he intended to buy and that therefore you have drawn up a contract which is ready for his signature.

If he is the indecisive person you thought him he'll sign, for he wants to badly enough, only, like the rest of his kind, can't decide to do so. And your conscience needn't trouble you, for you will really have done the poor fellow an inestimable favor. He wanted that Victrola just as badly as the reluctant swimmer wanted the swim, but needed a good strong shove.

The Davidson Co. has taken over the Victrola department of the James Black Drygoods Co., Waterloo, Ia., and has moved it to the front of their store. L. E. Cohen is in charge of the department.

The World Phonograph Shop is the title of a new concern at 1518 California street, Denver, Colo.

LONG CABINETS



No. 83

In all finishes. Specially adapted for use with Columbia 50, Model "D." Front posts made to follow lines of posts on Columbia 75, Model "F."

FIRST and FOREMOST

In the cabinet field.

Why? Because we've *specialized* in

**CONSTRUCTION
FINISH and
ADAPTABILITY**

Our supremacy in these essentials warrants your handling *the perfect line*.

That's why you should anticipate your wants **NOW**.



No. 79

In all finishes. Shown with top moulding and shelves. Specially adapted for use with Victrola IX-A.

Prompt deliveries on all orders. Write for Illustrated Catalogue of complete line

THE GEO. A. LONG CABINET COMPANY
HANOVER, PA.

**BUY YOUR ALBUMS
DIRECT FROM
THE MANUFACTURER**

Pat. Dec. 15, 1914



**THIS ALBUM MADE
US FAMOUS BY
SELLING IT.
WHY
DON'T YOU TRY?**

BOSTON BOOK COMPANY, Inc.
43-51 Fourth Avenue, New York, N. Y.

**INTEREST GROWS
IN FOREIGN TRADE**

Firms Planning Selling Campaigns Abroad—Bureau of Foreign and Domestic Service Called Upon to Supply Data on Conditions in the Foreign Field for American Manufacturers

The signing of the armistice putting an end to hostilities in Europe acted as an immediate and powerful stimulant to interest in American export trade, according to information obtained at the district office of the Bureau of Foreign and Domestic Commerce, 734 Custom House. This active branch of the United States Government is now being called upon for a wide range of data concerning foreign markets for American goods by manufacturers whose war orders have prevented them from meeting the demands of the average foreign customer and who will soon be free to return to their normal export business.

The number of firms who are planning serious selling campaigns abroad is steadily increasing, and the local office of the Bureau of Foreign and Domestic Commerce is constantly in consultation with such houses. It is estimated that the number of requests for assistance has doubled during the past month. Although it will probably be six months or more before there is a material improvement in the shipping situation, the Government is facilitating in every possible way the conduct of our foreign commerce, and success in selling American goods abroad is going to depend largely upon the degree of co-operation which exists between the Government and private interests, but more particularly upon the extent to which our manufacturers and exporters utilize and encourage the Bureau of Foreign and Domestic Commerce. It is planned to make the New York office of the bureau the greatest foreign trade service station in the world, and this will be done if a sufficient appropriation is made by Congress for increasing the bureau's organization at home and abroad.

Our competitors in foreign markets have always made scientific accuracy a primary consideration, while, in the past, many American exporters have been too prone to depend upon guesswork and too willing to take unnecessary chances. It is the bureau's aim to place our export trade on a sound and scientific basis by collecting the most accurate and complete information about foreign markets that can possibly be secured. Additional commercial attaches are being appointed to cover certain

countries in Europe, and trade commissioners are being sent to Latin America and the Far East. These men will make a careful study of their respective fields, and millions of dollars' worth of business will come to the United States as a result.

The import and export statistics of the United States, which are compiled by the Bureau of Foreign and Domestic Commerce, will be revised and extended, according to a plan now being carried out. More than 1,500 new items will be added to the export classification, and the import items shown will be increased.

An important phase of the bureau's work is the collection of samples of goods sold in different parts of the world. These articles are exhibited in the New York Custom House.

CHANGE IN CHICAGO OFFICE

The Thomas Mfg. Co., Dayton, O., manufacturers of talking machine motors and parts, will move their Chicago office on January 1 from the tenth floor to Suite 1500 in the Republic Building. L. Baxter, formerly manager of their factory at Dayton, is now in charge of their Chicago interests.

The Schubert Phonograph Co. has opened new salesrooms at 705 Twelfth street, N. W., Washington, D. C.

**CABINETS and TALKING MACHINES
for WHOLESALERS, DEALERS, JOBBERS**



We can supply you with high grade talking machines to suit your every need. While we are cabinet makers we also manufacture complete machines.

We have a large stock prepared ready for shipment to meet the requirements of the trade.

Prompt Deliveries

Inquire for Catalog and Price List of

BEN FERRARA
ONEIDA, NEW YORK

What Have You to Sell?

We purchase in any quantity, anything you have for sale in the talking machine industry. The larger the quantity the better we like it. We can use cabinets, motors, tone arms, reproducers, strings, tabulators, micas, machine screws, wood screws, etc., etc., in job lots, or regular merchandise if the price is satisfactory. Get in touch with us on anything you have to sell.

LUCKY 13 PHONOGRAPH CO.
46 East 12th Street, New York

EDUCATIONAL PUBLICITY

Attractive Hangers in Colors Just Sent to the Trade by C. Bruno & Son, Inc.

"Try These Victor Records" is the title of an attractive hanger that has just been prepared by C. Bruno & Son, Inc., Victor wholesalers, for the use of Victor dealers. This hanger, which is designed in two colors, is conveniently sized for insertion in the usual record fixtures and can therefore be presented by the dealers to excellent advantage.

In a chat with The World C. Bruno stated that this hanger was prepared with the idea of assisting the dealers in moving records which are not generally asked for by the public, because they do not know of them. Mr. Bruno found that quite a number of Victor dealers have stimulated an active demand for these records and other so-called slow-moving records by calling the attention of the customers to them, keeping the records handy in the booths, and playing them whenever the occasion presents itself. The use of this hanger will undoubtedly assist Victor dealers in developing a demand for these records.

PATHE LINE FOR BYRON MAUZY

SAN FRANCISCO, CAL., December 2.—The talking machine department of Byron Mauzy has just added the Pathé lines, placing an initial order of \$5,000 with the Western Phonograph Co., Pathé distributors in San Francisco. The first shipment the music house has received includes several art models and a few of the more expensive types. The department has also been promised a carload of Columbia machines for early delivery.

SELLING COMPANY ORGANIZED

The J. T. Ritley Selling Co., Denver, Colo., has been organized to distribute phonographs to certain Western States. The company's offices are in the Charles Building.

EVEN PHONOGRAPHS "CARRY ON"

Here is shown an interesting survivor of the great war. Though suffering from a jagged shell hole through its sound deflector, this Sonora style portable phonograph is by no means "hors de combat," for it still can play acceptably. The instrument here shown, after two years' service in France, was presented to the British National War Museum. Painted on its case



A Survivor of the War

are the names of the battles in which it has seen service.

The letter of acceptance sent to its donors is as follows:

"National War Museum, May 27, 1918.

"I am directed by the chairman of the National War Museum (the First Commissioner of Works) to thank you warmly on behalf of His Majesty's Government for your gift to the National War Museum which is much appreciated and will be carefully preserved for all time as a national relic."

MAKE MUCH PROGRESS DURING YEAR

Hoffay Talking Machine Co. Keeps Production at Excellent Average Despite the Numerous Handicaps Presented as Result of War

The Hoffay Talking Machine Co., Inc., have just made an announcement regarding the progress the concern has made during the past year—and despite war conditions. The reports show that they have made substantial advances not only in the output of their products, but in adding to their organization several very representative distributors in different parts of the country. The number of dealers that have also been made Hoffay agents has been quite large, and from present indications the president of the company, Joseph Hoffay, feels that during the coming year his organization will have such recognition in the talking machine field as he feels his product justifies.

"NEWT'S" FOR DECEMBER READY

The December number of "Newts," the monthly house organ by Stephenson, Inc., edited by Frank Nutze, is now in the mails, and, as usual, the contents is filled with stories of life and there is also much in the way of philosophy. According to reports the "Newts" is being received by the trade as a little magazine that is greatly sought.

SEND FOR ILLUSTRATED PRICE LIST AND FREE SAMPLE
"GLOBE" TRANSFER NAME PLATES
 DEALERS EVERYWHERE APPLY THEM ON PHONOGRAPHS, PIANOS, ETC.
GLOBE DECALCOMANIE CO.
 JERSEY CITY, N. J.

EMPIRE RECORDS FOR JANUARY

CHICAGO, ILL., December 11.—The advance list of records for January just issued by the Empire Talking Machine Co. is as follows:

- POPULAR HITS OF THE DAY**
- 6256 When You Come Back (And You Will Come Back) (Cohan). Baritone solo.....Louis Winsch
 - Three Cheers for the Army and Navy (Thompson). Tenor solo.....Ira Allen
 - 6257 That's What Ireland Means to Me (Hanley). Tenor solo.....Henry Burr
 - On the Road to Home, Sweet Home (Van Alstyne-Kahn).....Sterling Trio
 - 6258 There's Someone More Lonesome Than You (Von Tilzer).....Campbell and Burr
 - And I Am All Alone (from "Have a Heart") (Kern). Tenor solo.....Henry Burr
 - 6259 A Little Bit o' Honey (Bond). Tenor solo, Henry Burr
 - On Lake Champlain (Bryan-Gumble).....Sterling Trio
 - 6260 At the End of a Beautiful Day (Perrins). Tenor solo.....Henry Burr
 - Chimes of Normandy (Wells). Contralto solo Jean Sterling

- COMIC SELECTIONS**
- 6261 An Old Horse That Knows His Way Home (Olman). Baritone solo.....Louis Winsch
 - He's Always Hanging Around (Sissle-Blake). Tenor solo.....Ira Allen
 - 6262 Miss Sirmantha Johnson's Wedding Day (Jackson).....Collins and Harlan
 - Good-Night, Angeline (Sissle-Blake). Tenor solo.....Ira Allen
 - 6263 Cohen Telephones the Real Estate Office. Humorous monologue.....Morris Briel
 - The Coon Mariners. Humorous dialogue, Golden and Marlowe, Comedians
 - 6264 From Here to Shanghai (Berlin), Collins and Harlan
 - Yukaloo (Van Brun-Von Tilzer).....Sterling Trio

- HAWAIIAN SELECTIONS**
- 6265 Southern Blues. Characteristic Hawaiian melody.....Louise and Ferera
 - Honolulu by the Sea (Jack Frost), Campbell and Burr
- DANCE SELECTIONS**
- 6266 Lights Out (McCoy). March or two-step, Empire Military Band
 - Liberty Lads (Smith). March or two-step, Empire Military Band
 - 6267 Dance With Me (from "The Grass Widow") (Pollock-Wolf-Hirsch).....Empire Band
 - Paddle Addle (Snyder). Medley fox-trot, Empire Band
 - 6268 Beale Street Blues (Handy). Saxophone, xylophone and piano.....Davies Trio
 - Lily of the Valley (Friedland). One-step, Empire Dance Orchestra
 - 6269 The Jazz Dance (Overstreet). Fox-trot, Blake's Jazzone Orchestra
 - Going Up (Harbach-Hirsch). Medley one-step, Empire Military Band
 - 6270 My Dough Boy (Frey). One-step medley, Klass' Accordion Dance Orchestra
 - Goulash (Egan). Medley fox-trot, Klass' Accordion Dance Orchestra

Fred Carton has been appointed sales manager of the D. W. Lerch Co., Canton, O., which concern in addition to pianos and players also handle Vocalions and Grafonolas.

CULPTONE
 TRADE MARK
 Made UP to a Standard
 Not DOWN to a price
 NEW YORK



Prices Range from \$80 to \$160
 Four Styles

Territory open for Agents
 Send for details and dealers' discounts
 Helpful booklets furnished to Culptone dealers free
Culp Phonograph Co.
 240 Broadway
 New York City

Ready for Immediate Delivery

SCHUBERT
Double Disc RECORDS
 A \$30 Record Investment Starts YOU with complete, up-to-date list of Popular Vocal and Instrumental Selections
10-INCH DOUBLE DISC
 20 to 30 New Selections Monthly
 We guarantee you against loss of Record Investment.
 Liberal Discounts Send for Details
BELL TALKING MACHINE CORPORATION
 (Record Department)
 44 WEST 37th STREET, NEW YORK, N. Y.

NEEDLES
 WE MANUFACTURE
 Diamond needles for Edison
 Sapphire needles for Edison
 Sapphire needles for Pathe
 in stock ready for delivery
MERMOD & CO., 505 5th Ave., N. Y.

REPAIRS
 All Makes of Talking Machines Repaired Promptly and Efficiently
 TALKING MACHINE REPAIR AND SALES CORPORATION
ANDREW H. DODIN, President
 176 Sixth Avenue New York
 TELEPHONE, CHELSEA 8437

BROOKS AUTOMATIC REPEATING PHONOGRAPH



THE WONDER INSTRUMENT

Plays and repeats any kind or size record—any desired number of times—then stops automatically with the tone arm suspended off to the right in the air. Any child can operate it.

WONDERFUL TONE **WONDERFUL FINISH**
WONDERFUL IN ITS SIMPLICITY

The Machine Creates Interest and Discussion.
It is Self-Advertising

WONDERFUL SELLER

DEALERS—Send for Particulars, Prices, Terms.

BROOKS MFG. CO., Saginaw, Mich.

PLANT IS TAXED TO CAPACITY

The Cleveland factory of the Empire Phono Parts Co. has been taxed to its capacity to keep pace with the demand for the high-grade tone arms and sound boxes that they are manufacturing, and W. J. McNamara, the president, is figuring on a large increase in the equipment of the factory as soon as the present rush subsides sufficiently to enable him to carry out the plans he has made to that end. The Empire tone arm and reproducer have been adopted as standard equipment by some of the highest class manufacturers of talking machines, and a number of others have signified their intention to adopt the Empire equipment for 1919. The fact that it pays to advertise in The Talking Machine World is strikingly attested by the returns that have come to the Empire Phono Parts Co. as a result of their advertising in that medium. Inquiries have been received from practically all over the world, including China, Japan, India, Australia and Africa, and practically all of the concerns now using Empire equipment were secured through inquiries in answer to ads in The World, as the company employs no traveling men, and the only representative they have is C. L. Stephenson, of 1765 Broadway, New York, who looks after the Empire trade in that territory, and has built up a very satisfactory volume of business with some of the leading Eastern manufacturers.

SPENDS FEW DAYS IN NEW YORK

I. A. Lund, who has been doing some very effective work for the Mandel Manufacturing Co., of Chicago, Ill., on the road, throughout central western points, was a visitor to New York last week, and was very buoyant over the immense demand for the Mandel phonograph in the territory which he controls. Mr. Lund is a practical efficiency expert and has done splendid work for the Mandel institution in the production end of this enterprise, and he is doing just as efficient work on the road. This change of operations gives him a chance of getting in thorough sympathy with the needs and demands of the traveling men and the talking machine trade generally.

Emerson New England, Inc., was recently chartered under the laws of New York with capital stock of \$75,000 to engage in the phonograph business in this State. The incorporators are M. D. Dewitt, H. M. Van Aken and M. C. Flanagan.

Nature won't stand for overdrafts any more than your bank.

A. P. BURNS AN ACTIVE FACTOR

Assistant Sales Manager of Thos. A. Edison, Inc., Full of Real Information

One of the active factors in the Edison organization is A. P. Burns, the assistant sales manager, who gained a first-hand insight into all phases of the business while on the road for that company, and is now looked upon as



A. P. Burns

an authority on transportation and the other problems of shipping and traveling. He knows. Incidentally, Mr. Burns has sales ability of no mean sort, and persistence back of it.

"Burns is a nuisance," Tom Leonard, his boss, insists. "He's so everlastingly persistent. Once let him get started after anything and nobody in the office gets any peace until it is accomplished—which is extraordinarily soon, by the way. He has a lot of correspondence with the dealers, and his follow-up letters must be their despair! Whatever he means them to do they do eventually, in self-defense."

Harold Orth, of the Denver Music Co., Denver, Colo., who was a member of the Officers' Training School at Camp McArthur, Waco, Tex., has received his discharge from the service and again taken up the threads of business.

The Phonographic Atelier, Inc., Wilmington, Del., was incorporated this week with the Secretary of the State for the purpose of manufacturing phonographic records, etc. Capital. \$145,000.

GIRL EDITOR FOR 'ALONG BROADWAY'

Laura Scribner, Vassar, 1918, has been appointed associate editor of "Along Broadway," the bright little publication issued by Thomas A. Edison, Inc., and has already made good in her new position, indicating that Tom Leonard, general sales manager of the company, was right when he demanded a girl editor for that publication, of which Verdi E. B. Fuller is managing editor.

When he decided to get a college girl Mr. Leonard telegraphed at once to Vassar, and Miss Scribner arrived at Edison headquarters the next day.

HOFFAY



Read the Trade Mark carefully, hear the machine, and you'll agree that it is truly
The World's Musical Instrument
Improves All Records

"The World's Musical Instrument—not a phonograph"

MEANS QUALITY AND MONEY. THE GOOD PART OF IT IS THAT IT LOOKS WHAT IT IS

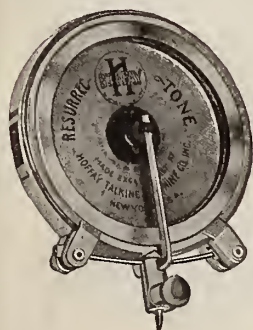

Our 1916 sales were nothing compared to those of 1917, while those of 1918 have increased many times over.

Our lately improved products, which we fully guarantee, together with our liberal proposition, make it a sure fact that 1919 will smash to bits our record of 1918.

A Happy Christmas and that you may enjoy with us the Prosperity of 1919 is our heartiest wish.

HOFFAY TALKING MACHINE CO., INC. 3 WEST 29TH ST. NEW YORK CITY

\$125



Height, 44
Width, 20 1/4
Depth, 20 1/4
Other Models
\$175, \$225, \$275

WORLD'S CLASSIFIED ADVERTISING

Any member of the trade may forward to this office a "Situation" advertisement intended for this Department to occupy a space of four lines, agate measure, and it will be inserted free. Replies will also be forwarded without cost. Additional space will be at the rate of 25c. per line. If bold faced type is desired the cost of same will be 25c. per line.

PHONOGRAPH RECORDER WANTED, experienced, capable and enterprising. Will make good proposition for all or part time. Confidential. Address "Box 565," care The Talking Machine World, 373 Fourth Ave., New York.

RECORDING EQUIPMENT WANTED; new or second-hand, also shaver, tanks, dies, presses, lathes, rheostats, etc. Address "Box 566," care The Talking Machine World, 373 Fourth Ave., New York.

WANTED—By January first want to connect with large talking machine manufacturer who makes a medium-priced line, to sell through the South and Southwest in connection with line of pianos. Have strong following among the best rated piano and furniture concerns in this territory. Best of references furnished. Address "Box 567," care The Talking Machine World, 373 Fourth Ave., New York.

SALESMAN WANTED to take orders for standard article in great demand all over the country; sold in phonograph stores, drug stores, stationery, hardware, dry goods stores, etc. Steady employment and liberal remuneration. Address "Box 568," care The Talking Machine World, 373 Fourth Ave., New York.

DOUBLE PRICE is offered for Columbia Record A5116. Address A. O. Lamson, 216 Fulton St., New York.

A FEW shares offered, start at big discount, involving manufacture of new highly developed phonograph. Address "Box 574," care The Talking Machine World, 373 Fourth Ave., New York.

SALESMAN WANTED—If you cover the phonograph trade in any section of the United States and are interested in a live proposition, either as a side line or as your main line, we have an interesting offer. In answering state territory now covered. Address "Box 522," care The Talking Machine World, 373 Fourth Ave., New York.

LARGE Record Manufacturer desires services of high-class salesman for Middle West among jobbers only. An excellent opportunity to make big money. Address "O. C. 10," care The Talking Machine World, 209 South State St., Chicago, Ill.

WANTED—New and second-hand Victor and Columbia talking machines and records. Spot cash paid for them. Deninger Cycle Co., Rochester, N. Y.

SALESMAN wants to carry line of phonographs through the entire South on commission basis. Address "Box 569," care The Talking Machine World, 373 Fourth Ave., New York.

SITUATION WANTED—Manager of Victor store with eight years' practical experience in large Eastern city wishes to connect with firm on salary and commission basis. Has good education and genial personality. Address "Box 570," care The Talking Machine World, 373 Fourth Ave., New York.

WANTED—Phonograph shop. Victor shop preferred with or without Kodak agency. Complete details in first letter. Address "Box 571," care The Talking Machine World, 373 Fourth Ave., New York.

POSITION WANTED—Live-wire wants to hear from firms contemplating to extend business to Asia Minor (an excellent field), also Balkan States. Big opportunity. Address "Important," The Talking Machine World, 373 Fourth Ave., New York.

WANTED—Salesmen to carry line of well-known music rolls and phonograph accessories on commission basis. Address "Box 561," care The Talking Machine World, 373 Fourth Ave. New York.

POSITION WANTED—Talking machine salesman, five years' experience, expert repairman, can take full charge, can handle both American and foreign trade. Address "Box 562," care The Talking Machine World, 373 Fourth Ave., New York.

PHONOGRAPH recorder required, thoroughly experienced and able to install and operate. Replies confidential. Address "Box 558," care The Talking Machine World, 373 Fourth Ave., New York.

POSITION WANTED—City salesman or department manager—by man of twelve years' experience. Best references. State particulars. Address "Box 549," care The Talking Machine World, 373 Fourth Ave., New York.

SITUATION WANTED—Salesman (35) acquainted with every angle of the business. Phonographs, records and sundries. Vigorous result getter on road. Drawing account against commission. Address "Phonographs," 22 East 125th St., New York.

POSITION WANTED—Talking machine salesman, five years' experience. Inside position large city preferred. Familiar with all well known machines. References. Address "A. P. 2," Talking Machine World, 209 So. State St., Chicago, Ill.

WANTED—Thoroughly experienced, aggressive Edison, Victor and Columbia manager is open to manage department. Any location. Success guaranteed. Address "J. L. 8," care The Talking Machine World, 209 South State St., Chicago, Ill.

SITUATION WANTED—Trade builder open for position November 1. My record of sales will be of interest to manufacturers who wish to further their output. Address "Box 560," care The Talking Machine World, 373 Fourth Ave., New York.

To Phonograph or Record Salesmen or Dealers

If you think you could sell a brand new attachment, which goes on the Victor sound box and *remains there permanently*, which is so simple a *child* can put it on, which when used enables the Victor to play all records with equal beauty of reproduction without removing or *turning the sound box* and which is protected by *basic patent applications*, we would be glad to have you write us telling us in what territory and how you expect to sell the attachment. Address "Box 575," care THE TALKING MACHINE WORLD, 373 Fourth avenue, New York.

WILL YOU HIRE BRAINS?

I know the phonograph business thoroughly from the retailer's standpoint. I know his problems, and how to meet them, from actual experience. I started a store a couple of years ago with practically nothing and have built it up to be the leading store for both machines and records in its neighborhood.

My capital is limited, and keeps me from doing things in a big way. My initial success has been so great that I feel that I can take hold of a much larger proposition and build it up.

If there is some manufacturer or distributor of machines or records who needs an active young man, let us meet. Address "J. M.," care The Talking Machine World, 373 Fourth Ave., New York.

FOR SALE

Phonograph records, lateral cut, 10 and 12 inch standard make, a fine assortment of vocal and instrumental selections. Steel phonograph finest quality, 100 to envelope, 60 cents per thousand.

I. DECKINGER

3064 Albany-Crescent Ave. New York

RECORDER

Thoroughly experienced recorder, familiar with all departments of record manufacturing and wax making. Own complete lateral and vertical instruments, accessories, wax formulas, etc. Competent to efficiently handle any part of recording work. Desires permanent connection where conscientious work is appreciated. Address "Box 573," care The Talking Machine World, 373 Fourth Ave., New York.

WANTED

Victor talking machines and records. Highest cash prices paid. No quantity too large. Call, write or phone.

TERMINAL EXCHANGE

1208 Filbert Street, Philadelphia, Pa.
Bell Phone, Locust 5716 Always Open

Pre-War Prices ON PHONOGRAPH PARTS

Motors, double springs cpt. with 12" T. T., each.....	5.00
Motors, single spring cpt. with 10" T. T., each.....	2.25
Tonearms, universal, with mica soundbox No. K-1, each.	1.75
Tonearms, universal, No. H2, Sonora style, each.....	2.75
Soundbox, fit Victor tonearm, No. H-1, each.....	1.50
Soundbox, fit Standard tonearm, No. K-5, each.....	0.75
Main springs for Edison disc, 1 1/4", each.....	1.75
Main springs for Columbia disc, 1", each.....	0.60
Main springs, 3/8" oblong hole, each.....	0.35
Main springs for Columbia disc, 3/8" round hole, each...	0.30
Main springs, 5/8" x 0.20 x 8", each.....	0.30
Main springs, 1 1/4", fit Victor, each.....	0.70
Governor springs for Columbia motor, each 2c.; per 100..	1.20
Governor springs for Victor motor, each 2c.; per 100....	1.20
Governor screws for Columbia motor, each 1c.; per 100...	0.50
Governor shafts for Bllek or Wonder motor, each.....	0.15
Governor shafts for Heineman No. 0 or 11, each.....	0.20
Steel needles, full-tone, in envelopes, per 1,000 needles...	0.60
Sapphire needles for Edison disc, each.....	0.30
Sapphire needles for Pathé disc, each.....	0.30
Genuine Edison diamond for disc, each.....	2.25
Mica diaphragms, 1st for Victor soundbox, each.....	0.15
Mica diaphragms, 1st for Columbia soundbox, each.....	0.25
Mica diaphragms, 1st for all Standard soundboxes, each.	0.22
Mica diaphragms, for Pathé and Brunswick, each.....	0.50
Turn-table, felt green, 10", each.....	0.15
Turn-table, felt green, 12", each.....	0.20
Barrels, assembled, for Bllek or Triton motors, each....	0.60
Barrel, bottom gears, Bllek or Triton motors, each.....	0.15
Needle cups, fit on Columbia, per 100.....	2.25
Needle cups, with covers, for used needles, per 100.....	3.75

FAVORITE PHONOGRAPH ACCESSORY CO.

1491 DeKalb Avenue

Brooklyn, N. Y.

CABINETS

A few hundred cabinets of several different styles, all in excellent condition, are available for immediate shipment. Both quartered oak and birch mahogany finish.

McLANE MFG. CO.

Milford,

New Hampshire

BUSINESS OPPORTUNITY

Piano and Talking Machine Store for rent, account sickness. Splendid chance for live man to step into money making place. Location has been music store for years. Only one in city of 10,000. Rent \$40.00. Six months free. Sheet music department owned by another party.

THE DEMING MUSIC CO.

Deming Building

Redlands, California.

VICTORS

COLUMBIAS, EDISONS, SONORAS, PATHE AND OTHER MAKE PHONOGRAPHS FOR SALE, ENTIRE LOT OR SEPARATELY. MAKE YOUR OWN PRICE. QUICK ACTION REQUIRED. CHANCE OF A LIFETIME.

DEUTSCH BROS.

3rd Ave. and 133rd St.,

New York City

WANTED

By a progressive company a man who knows music and has mechanical ability and wishes to learn the art of recording. We will pay a good salary while learning. An opportunity for the right man. Please state fully in application all facts which would be of interest. Address "Box 576," care The Talking Machine World, 373 Fourth Ave., New York.

WANTED

Victor and Columbia records, new and second-hand. State condition.

PLAYER ROLL & RECORD EXCHANGE

901-903 Marquette Ave.

Minneapolis, Minn.

FOR SALE

On account of ill health am compelled to dispose of my business, Columbia Agency, and full line of records. Ideal location with 75,000 population to draw on. For further details address "Box 572," care The Talking Machine World, 373 Fourth Ave., New York.

HOW MANY SAVED MONEY

During the period of the war many concerns adopted the practice of saving all the twine, cord and string used to bind incoming parcels and packages, and in this way accumulated a large part of the necessary cord, etc., needed for binding outgoing packages. This is a plan which should still show a substantial saving if continued during peace times.

The
CHENEY
 PHONOGRAPH
"Plays all records better"

Dealers are invited to inspect this instrument which is so distinctly different from all others.

Attractive agency proposition. Liberal advertising plans. Write for catalog and full particulars.

H. L. ROYER, New England Representative

77 SUMMER STREET, Room 59 - - - - - BOSTON

**LISTENING LIBRARY
 A CHARACTER GAUGE**

Talking Machine Records Are to the Ear What Books Are to the Eye—Character of the Records in Library a Guide to Owner's Culture

Very constructive and helpful articles of value to the dealer, and of interest to the buying public, are being published in that section of the Chicago Evening American under the caption of "The Buying American." The subject of talking machine records was recently discussed in a manner that afforded some ideas that might be utilized by the retailer to good purpose. It was under the caption of "The Listening Library" and ran as follows:

"We call it our listening library," she said as she opened the doors of the talking machine and disclosed the rows of records compactly arranged in groups.

"Listening library is good," I replied. I had never thought of a collection of talking machine records in that way before.

"Talking machine records are to the ear what books are to the eye," she went on. "I try to carry the simile farther. I try to make our listening library just as well rounded, just as complete and just as up-to-date as our library of well-loved books. My father used to say, 'Tell me what you read and I'll tell you what you are.' A glance at your book cases was all he needed to size up your character. But I maintain that to-day your talking machine records are an even more accurate character-gauge than your books. And just as no library of books, even though it be but the 'five-foot shelf,' is complete without certain 'classics,' so is no library of records complete without its old-time favorites."

"Do you remember in William Dean Howells' masterpiece, 'The Rise of Silas Lapham,' how the paint manufacturer's family became wealthy and, moving into a fashionable Boston square, suddenly realized their lack of books? And how disturbed they were lest they buy the wrong ones, until an intellectual friend offered some helpful suggestions?"

"Neither the Silas Laphams of to-day nor any-

one else need have any fears in selecting their listening libraries. The test of the worth of a record is not in what some critic may have said about it. Nor is it in the endorsement of generations past.

"The simple test is. Do you like it yourself? Does it please you when you hear it?"

"There is this advantage, too, in selecting a listening library: When you add a book to your shelves, you must buy it before you read it—and until you read it, you cannot be sure it will please you. When you add a record to your collection you may hear it before you buy. Your satisfaction is guaranteed in advance.

"No pig-in-a-poke purchase, this. But just as the book library must be kept interesting and

fresh by the addition of 'best sellers' or some much-talked of new volumes from time to time, so must the record library be replenished frequently with the new productions.

"That catchy song, direct from the Winter Garden—that newest march of the march king—that patriotic air the bands are all playing and the boys in uniform all whistling—you need these to keep your listening library up to snuff.

"When folks come in for the evening, are you entertaining them with something new or boring them with 'old stuff'?"

"When Joe Nextdoor asks, 'Oh, boy, have you heard the latest dance hit?' there's a barrel of satisfaction in answering, 'Listen, here it is!'"

"When Mrs. Breeze prates about the opera, what a comfort to say, 'Oh, yes, we have it on our talking machine.'"

"Buy records as you buy books. You do not choose a book because it is cheap, but because you want it. Price doesn't count. 'Pay a little more for the good record,' is sound advice. Remember, you've got to live with it. You don't want your book shelves stuffed with trashy dime novels—nor your talking machine shelves with records that you'll hate to-morrow. The best music is the least expensive, no matter what it costs, because it wears best.

"One good record once a month is better than a bushel of 'cheap stuff' once a year. Buy monthly, buy carefully, discriminately, and your listening library will soon be, not only large, but worth listening to."

ATTRACTIVE DELIVERY CAR OF AN EDISON DEALER



Edison Delivery Car Used by J. H. Gehring

The accompanying photograph shows a most attractive delivery car recently put in service by J. H. Gehring at Delta, O. The car is painted a bright lemon color trimmed with black and attracts a great deal of attention in its busy activities throughout the neighborhood. Mr. Gehring claims it is the only car in the county painted anything like it and that it "makes the people sit up and take notice."

S. Kann, Sons & Co., big department store in Washington, D. C., has secured the agency for the Sonora line for its talking machine department.

B. S. Porter & Son, Findlay, O., have formally notified the public that they have discontinued the practice of sending records out of the store on approval.



Eight Models Retailing from \$30 to \$275

A FRANK DISCUSSION

¶ There are more than a hundred phonographs that have been presented to the trade recently by different manufacturers. They ALL claim superiority of every detail—cabinet design, finish, motor, tone, etc. It is very clear that ALL these instruments cannot be BEST. Some of these manufacturers are at least mistaken.

¶ You recall many things that were seemingly satisfactory until BETTER ones appeared. That is exactly the case with phonographs—the instrument of yesterday "paved the way" and to-day there is but ONE best in phonographs, the SONA-TONE—it is the NEW PHONO-

GRAPH and BETTER, just the same as America is the NEW WORLD and BETTER.

¶ Mr. Thomas Dixon, of "Birth of a Nation" fame, says: "It is the sweetest and clearest toned instrument I have ever heard."

¶ You do yourself an injustice if you do not investigate the SONA-TONE, the last and FINAL word in phonographs. The only Over the Top.

¶ REMEMBER, the SONA-TONE sells on sight and it STAYS SOLD; no come-backs. Liberal trade proposition, immediate deliveries, and exclusive territory.

Write us to-day.

SONA-TONE PHONOGRAPH, Inc.

Office and Sales Room, 322 Livingston Street, Brooklyn, N. Y. Factory, 691 Bergen Street, Brooklyn, N. Y.

FROM OUR EUROPEAN HEADQUARTERS

2 GRESHAM BUILDING, BASINGHALL STREET E. C., LONDON, W. LIONEL STURDY, MANAGER.

Reasons for Real Christmas Feeling in the Trade This Year, Owing to the Signing of the Armistice—The Collapse of the Great German Empire Means That Trade and Commerce Will Again Be Resumed—Plans for Reconstruction Now Under Way—Gramophone Co. Hold Annual Meeting—Sales Break All Records—News of the Month Worth Recording

LONDON, E. C., ENGLAND, December 2.—The sacred significance of Xmas-tide will this year be emphasized by the glorious result achieved in behalf of the ideals of civilization. There is a great and simple sincerity in the good old greeting—Peace on earth and good will to all men. Joy will reign supreme in the homes of the people, though in thousands tempered by the sorrowing thoughts of those left to mourn the loss of loved ones who have made the supreme sacrifice. Might now pays homage to Right; the world and men are advantaged thereby. This Xmas-tide will witness an almost universal celebration of the Allies' glorious achievement. It is in a special sense therefore that I extend to all readers the compliments of the season, in the knowledge that circumstance lends itself to a real enjoyable time free from the strain and effects of war.

The collapse of the mighty German Empire and its allies—Austria, Bulgaria and Turkey—brings us to the consideration of those post-war commercial prospects about which reams of advice have been proffered by doughty newspaper and other scribes. Now we are really up against it, and the world is watching. The race for trade supremacy will shortly set in with a vengeance. The keynote of success is organization. Each country has to put its house in order on the basis of reconstruction. The British Government is alive to the situation and has put into operation machinery for bringing into effect the many plans for an early re-establishment of peacetime industries. A multitude of problems and difficulties present themselves, demanding the exercise of quick decisions by intelligent men of affairs and experienced statesmen. There is immediate need for a powerful progressive policy which will assure to British manufacturers a plentiful supply of labor and raw materials free of harassing restrictions. The question of tonnage, demobilization and the development of the resources of the Empire will receive priority of consideration. A reasonable control over demobilization of the services so as to prevent unemployment is to be exercised. Complete demobilization of the troops cannot take place under eighteen to twenty-four months. Discharge will be given according to a man's industrial value, and priority in this respect will go to key-industry men. The Government has dozens of committees at work dealing with these problems, and of various trade interests, and if it is not a case of too many cooks, etc., Great Britain should be in a favorable position to successfully grapple the great task of reconstructing the war-weakened fabric of industrial organization.

The difficulties confronting the musical instrument industry are many, but not all sections of the trade are identically affected. Being unsuitably equipped for war output, the gramophone record factories have largely escaped the Government's attention, and are therefore in a favorable position for normal activity once the labor question is overcome.

Minor restrictions regarding paper, certain record material, etc., remain, but as time proceeds a gradual improvement will come about, and it is not anticipated that these factories will be very greatly handicapped in their efforts to resume a normal output. On the machine side it is different. Such factories are engaged on

war work and will need time to finish up. This will be by arrangement with the Government, though in most contracts a termination clause exists agreeing a time limit upon the cessation of hostilities. The equipment of such factories will then need an entire rearrangement, probably the installation of balancing plant to secure an efficient mechanical layout for gramophone manufacture. We may rest assured that good plans exist for reconstruction in the foregoing respect and that no time will be lost in making the necessary change.

Most pianoforte factories are engaged, or partly so, on the manufacture of aeroplane parts. Here again, it will take a certain time to clear up, though in some cases it is rumored that manufacturers are in no hurry to resume pianoforte construction, owing to financial considerations. Evidently there is more money in aeroplane work than in piano output.

All things considered, there is every reason to believe that the labor claims of the trade and the question of raw material supplies will be strenuously pressed in official quarters for early consideration.

General Meeting of the Gramophone Co., Ltd.

At the ordinary general meeting of the Gramophone Co., Ltd., the chairman said that the trading profit this year was £218,749, and, adding the amount of £72,505 brought forward, made a total of £291,255. After deducting the usual items set forth in the report, amounting to £127,450, there was left a balance of £163,804 to be dealt with. The directors recommended the payment of a 10 per cent. dividend, less income tax on the ordinary shares, and a bonus of 5 per cent., less income tax, the setting aside of £50,000 for the equalization of future dividends, and carrying forward the balance of about £38,000.

He was in a position to state that during the year ended June 30 last the sales of gramophone goods in the United Kingdom had broken all records, and were larger than those of any previous year, either before or after the commencement of the war. To go a little further, he could inform them that the trade in the United Kingdom for last month (October) was also a record, being the largest sales of any month in the history of the company, and having regard to the change over from Government work to gramophone work, he was sure that that would be welcomed by all shareholders as an indication of the company's power to carry on. Dealing with a few of the principal items he pointed out that creditors on open accounts figured at £383,500 less than last year, and the stock-in-trade and work in progress also showed a decrease of £230,700.

Both these decreases were almost entirely due to a change of policy in the Government departments with regard to the financing of their large contracts. The cash item, £297,374, was less than last year by £50,266, due to the writing off of cash in enemy countries and in Russia. Trade investments were less by £87,300. The last four items on the liability side of the balance sheet totaled £520,125, and deducting the amount of dividend and bonus recommended they were left with a total of £445,125 accumulated cash working capital in addition to the issued capital of £600,000, and the debenture indebtedness of £300,000. How far all that capital was working capital in the true sense of the word was, in his opinion, the test of the value of the present balance sheet in face of the reconstruction period before them. The real working capital in their case was made up of three items, stock-in-trade and work in progress, the difference between debtors and creditors and cash. Those three items together, after deducting dividend and bonus from the cash item,

amounted to no less than £1,008,000. That was a very remarkable figure, and was a position which gave the directors confidence in the ability of the company to face the immediate future and the period of change-over with confidence, and enabled them to look forward to a glorious and profitable future.

Under New Management

The trade has been advised that W. H. Reynolds (1915), Ltd., has been placed under new management, and will continue business as heretofore at 22 City road, London, E. C. For the season's trade the firm are specializing on three types of hornless machines, each in its way being notable for careful workmanship and general all-round good value. In addition, a specialty is made of parts and accessories, of which a goodly variety is always in stock.

The Great Armistice Week

If we infringe the conventional rule of trade journals in making reference to other than strictly trade affairs, we make no apology; the great occasion being our best justification. Such a crowning victory as never before in the world's history! Four and a half years of patient faith, not always, we may now admit, without a measure of misgiving. The arms of civilization have achieved a glorious triumph over the dark forces of misapplied kultur, and it now remains a world duty to concentrate upon the reconstruction of the social and industrial fabric.

The armistice week was throughout one of wildly joyful excitement in England, and especially in London, where the news produced a remarkable expression of relief. Business was a secondary consideration and little could be done in view of the general feeling, to which of course the people had to give vent anywhere but in the office. One can yet scarcely realize that it is for all practical purposes a thing of the past.

New Winner Records

The latest Winners embody a number of titles which have found great favor among the masses on this side, and for which there should be a big demand from overseas. The Band of H. M. Irish Guards contribute two popular airs—"Over There" and "The Middy," both typical examples of good swinging marches, which naturally are much in vogue. The Winner exclusive, Ivor Foster, gives us a couple of attractive Irish items, and the famous Revue artists, Lee White and Clay Smith (who quite recently married), are down for two American songs, "In Alabama, Dear, With You," and "So This is Dixie." "Oshkosh" (whatever that may mean) and "Uncle Sam's Got a Great Big Stick," by The Two Bobs, should find a ready sale across the pond. Ernie Mayne, Ernest Rutterford, Kirkby & Hudson, artistes of renown on this side, also contribute popular songs to this fine Winner program. Selections I and II of "As You Were," the popular Revue now being played at the London Pavilion, go to the making of a splendid record by the Royal Court Orchestra. Of ten artistes who contribute to the list, it is a remarkable fact that no less than seven record only for the Winner Co.

The Death of Percy Dunlop

Just prior to the mailing of this month's report the sad news has been received of the death of Percy Alexander Dunlop, from the after-effects of malaria fever, in hospital at Salonica on October 28.

The deceased was well known in trade circles, where he was universally respected and esteemed

HARDWARE

Agent well in with best wholesalers in United Kingdom is prepared to take up American fancy and general lines at close of war. Mail particulars to G. Stewart, 111 Keith Road, Barking, Essex, England.

FROM OUR LONDON HEADQUARTERS—(Continued from page 112)

both on account of his kindly disposition and pleasing personality, as much as for the good work he never failed to undertake whenever an opportunity occurred so to do in the interests of the trade. Percy Dunlop joined the London Scottish in the early days of the war, and after seeing service in France was drafted to Salonica soon after the British and French troops took possession. His life has been given for his country, for he was a true patriot. We shall keep ever green the memory of his valued friendship. To Arthur Dunlop, the editor of our contemporary, *The Sound Wave*, with whom in pre-war days Percy was associated on the advertisement side of the journal, and to Mrs. Percy Dunlop, we offer our very sincere condolences in their irreparable loss.

Become Members

The following houses have recently been admitted to membership in the Association of Gramophone & Musical Instrument Manufacturers & Wholesale Dealers: M. Hirst & Co., 7a Grove road, Willesden, N. W. 2, gramophones and accessories; J. Stead & Co., Ltd., Manor Works, Sheffield, needle and spring manufacturers; West Bromwich Spring Co., Ltd., George street, W. Bromwich, spring manufacturers.

No Luxury Tax Legislation

In Parliament Bonar Law, the Chancellor of the Exchequer, recently informed an expectant House of the Government's intention to withdraw the proposed bill for the taxation of luxury articles, etc. But he was careful to express the hope that this source of revenue will not be overlooked when next year's budget is under consideration. The belief is general that this was Bonar Law's pet scheme for tapping an alleged spendthrift public of some of its surplus wealth. He didn't think it would act as a premium on reckless expenditure, or surely the bill would never have seen daylight, and so we are foredoomed by a quasi-official connivance to

another twelve months' financial freedom. The fact is that our dear Chancellor was reluctant to confess the failure of his proposal. It is more than doubtful whether he really cherishes the hope of introducing a luxury tax again. Nevertheless, the musical instrument trade appears to be somewhat nervous about it, for dealers and others have been exhorted to maintain pressure on local opinion with a view to collective action in official quarters if need be. It is as well to look both ways, but, all things considered, there seems to be little general apprehension of its revival, and indeed, it may truly be said that the trading community of this country has quite made up its mind that the Luxury Tax bill is dead.

Dealers Apprised of "H. M. V." Specials

Typical of this company's usual enterprising methods the following has been issued to all dealers:

"The November supplementary list is really a great collection of records, and it is difficult with such a magnificent list to choose any particular record as outstanding—they are all wonderful. However, we must point out the Elman String Quartet and would remind you of the huge success of the previous record issued, and Beatrice Harrison, Britain's greatest 'cellist, has made the finest 'cello record ever issued. Also listen to the 'Aida' selections by the Coldstream Guards Band. Make sure every customer hears these records and then—the biggest sales of the year. Yours faithfully, the Gramophone Co., Ltd."

Hough's Seventieth Anniversary Celebration

The speech made by J. E. Hough in connection with the celebration of his seventieth anniversary, when the trade gave him a luncheon and made him a presentation of silver, has aroused much favorable comment throughout all branches of the industry, for Mr. Hough is widely known and esteemed for his many admirable traits of character.

In his address he enlightened a great many of those present regarding the historical and technical aspects of phonograph expansion in this country, and dwelt on the developments of Edison, Bell and Tainter, and the various suits over patent rights, etc. He made interesting reference to the advent of the gramophone and Barry Owen's connection with it, and further enlightening data regarding the formation of the Gramophone Co. and the Edison Bell Co. He gave a lot of information regarding the latter concern, and his connection with it, leading up to the organization ultimately of J. E. Hough, Ltd.

Interesting American "War Records"

A striking feature of the new issues of Columbia records is an interesting series of American "war records" that should have a wide sale not merely among the "doughboys" over here, but also among their British cousins.

The war records are three in number, the first being an interesting vocal medley of the standard war songs of America such as "Yankee Doodle" and "Tramp, Tramp, Tramp." Another record is descriptive, first of the departure of the American troops for France, and, second, of the arrival of the American troops in France. The third record bears the song "Where Do We Go From Here?" and also a description of "Life in a Trench in Belgium."

New Records From Columbia

Unquestionably the best news the trade has had for some time is to the effect that the Columbia Co. issue new records this month. Out of seemingly insuperable difficulties coincident with the destructive fire at their Wandsworth factory, this company has come with flying colors, and once more the gramophone trade and the record lover may look with confidence to the continuance of that steady flow of records for all tastes. The new list of standard records is valuable and assuring evidence of the company's high intentions.



"His Master's Voice"

Copyright

'His Master's Voice'
—the trade-mark that is recognized
throughout the world as the
HALL-MARK OF QUALITY

Branches

DENMARK: Skandinavisk Grammophon-Akti-
eselskab, Frihavnen, Copenhagen.

FRANCE: Cie. Française du Gramophone, 115
Boulevard Richard Lenoir, Place de la Répub-
lique, Paris.

SPAIN: Compañía del Gramófono, 56-58 Balmes,
Barcelona.

SWEDEN: Skandinaviska Grammophon-Aktie-
bolaget, Drottning Gatan No. 47, Stockholm.

RUSSIA: The Gramophone Co., Ltd., 45, Nevsky
Prospect, Petrograd (Petersburg); No. 1
Solyanka, Solyanov Dvor, Moscow; B. Golovinsky
Prospect, Tiflis; Nowy-Swiat 30, Warsaw; 83,
Alexandrowskaya Ulitsa, Riga; 11 Michailovskaya
Ulitsa, Baku.

INDIA: The Gramophone Co., Ltd., 139, Bal-
labhatta Road, Calcutta; 7, Bell Lane, Fort,
Bombay.

Agencies

AUSTRALIA: S. Hoffnung & Co., Ltd., Sole
Concessionaries of The Gramophone Company,
Limited, 163, Pitt Street, Sydney.

NEW ZEALAND: Gramophonim, Ltd., 118-120
Victoria Street, Wellington.

SOUTH AFRICA: Darter & Sons, Post Box 174,
Capetown; Mackay Bros., Post Box 251, Johannes-
burg; Mackay Bros. & McMahon, Post Box 419,
Durban; Ivan H. Haarbinger, Post Box 105,
Bloemfontein; Franz Moeller, Post Box 108, East
London; B. J. Ewins & Co., Post Box 86, Queens-
town; Handel House, Kimberley; Laurence &
Cope, Post Box 132, Bnlwayo; The Argus Co.,
Sallshury.

EAST AFRICA: Bayley & Co., Lorenzo
Marques.

HOLLAND: American Import Co., 22a, Amsterd
Veerkade, The Hague.

ITALY: A. Bossi & Co., Via Orefici 2, Milan.

**EGYPT (Also for the Soudan, Greece and the
Ottoman Empire):** K. Fr. Vogel, Post Box 414,
Alexandria.

Great Britain :

The Gramophone Company, Ltd.

HAYES - MIDDLESEX - ENGLAND

**This intensely human pic-
ture stands for all that is
best in music**

—it is the "His Master's Voice"
trade-mark, and it brings to you,
no matter where you are, the
very best music of every kind,
sung and played by the world's
greatest artists—the greatest
singers, pianists, violinists, or-
chestras and bands—all enshrined
in the unequalled "His
Master's Voice"
records

LATEST PATENTS RELATING TO TALKING MACHINES AND RECORDS

WASHINGTON, D. C., December 8.—LID SUPPORT.—George W. Beadle, New Rochelle, N. Y., assignor to the American Graphophone Co., Bridgeport, Conn. Patent No. 1,280,637.

This invention is intended primarily for supporting the cover of the cabinet for a Gramofone or other talking machine; but it can be employed in other service, such as maintaining in desired position the hinged top of any box or chest or trunk, or any other movable closure or door. Among the objects of the invention are: to provide a contrivance by which the cover or closure can be opened or closed by one hand only; and, in case of a vertically-opening cover which, when lifted, would otherwise drop down by its own gravity, to prevent such unintended dropping of the cover; and to provide a device which will present the minimum obstruction in the angular opening of a hinged top or cover. Other objects and advantages of the invention will be apparent from the ensuing description.

The invention consists broadly of providing a pivoted guide-plate upon the box or stationary member, in combination with a rigid prop pivoted upon the lid or movable member, with suitable friction-means coacting upon said plate and prop.

Fig. 1 is a vertical section through a Gramofone cabinet, with its lid in its raised position, to present a side-view of a simple form of the

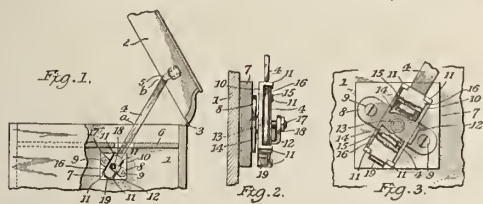

invention employed therewith; Fig. 2 is a front elevation, on a larger scale, of the same form of the device; Fig. 3 is a side-view of the pivoted guide-plate (partly broken away), and of its supporting-plate.

NEEDLE ATTACHMENT FOR SOUND REPRODUCING MACHINES.—Frederick W. Claybrook, Baltimore, Md. Patent No. 1,281,135.

This invention relates to attachments for holding the needle in sound reproducing machines with the object of absorbing the undesirable vibrations due to various causes and which result in harsh grating or screeching sounds; and also of reducing the wear on the record disc to a minimum.

As is well known, the channels in the record disc which are produced by the action of the needle in the sound recorder are undulating and vary in depth and steepness with the amplitude and pitch of the sound waves projected upon the diaphragm of the recorder. The needle of the graphophone, phonograph or other reproducing machine, following in these grooves or channels, is caused to vibrate in exact unison with the undulations, except for certain undesirable variations, and this, generally speaking, reproduces the same sounds in the horn or other sound transmitter.

Among the causes which contribute to undesirable sounds which interfere with the transmission of the true sound waves may be mentioned the following: When the undulations in the record channel are formed of gradual curves the needle follows faithfully all of the indentations, but if a very sudden or steep incline is encountered, the needle will be thereby thrown upward with greater rapidity or violence and may be caused to actually leave the record, immediately returning upon the rebound and not only producing a false tone or sound, but to a certain extent marring the record, many repetitions of this action resulting in wear and injury.

In order to accurately reproduce the sounds

or notes corresponding to the record, the vibrations of the needle must be caused solely by the recorded undulations. Like all bodies that are free to vibrate, the needle has a certain rate of vibrations of its own to which it will respond if that particular note or number of vibrations is impressed upon it. From this it follows that if perchance the needle encounters a certain number of undulations in the record to which it is attuned, or with which its natural vibrations are in synchronism, it will add its own vibrations thus produced to those caused by the record, thereby multiplying the amplitude of vibrations of the needle and producing a false note which is recognized as a screeching sound occasionally produced.

Undesirable sounds, such as the harsh grating sounds, are produced by the imperfections

in old or worn-out records. Foreign substances, such as particles of dust, encountered by the needle also produce false and undue vibrations which result in improper sounds. Certain of the causes above mentioned have been heretofore known and various attempts have been made to overcome the defects. Thus it has been proposed to surround the needle with a rubber sleeve and to interpose a rubber disc or block or a spiral spring, between the needle and the sound box in the endeavor to absorb undue vibrations; and also to remove the dust particles from the record by means of a separate brush holder clamped to the shank of the usual needle holder or to the casing of the sound box. Instead of analyzing the deficiencies of such prior devices it is deemed sufficient to point out the requirements and the manner in which they are embodied in the device disclosed herein.

In the accompanying drawings, Figure 1 is a side elevation of the usual sound box and needle holder of a phonograph together with a sectional view of a device embodying the features of the invention; Fig. 2 is a top plan view of the device; and Fig. 3 is an end view of the same showing the attachment of the brush.

WASHINGTON, D. C., December 5.—PHONOGRAPH.—Hans Brockmuller, New York. Patent No. 1,281,282.

This invention relates to a novel phonograph which is so constructed that its operative parts may be separately mounted upon and removed from an ordinary table or similar support, thus dispensing with the use of the cabinet heretofore generally employed. In this way the cost of the cabinet is saved, and the additional piece of furniture which it represents is entirely done away with, so that the device is available to persons of limited means or possessing but restricted dwelling accommodations.

In the accompanying drawing Figure 1 is a plan of a phonograph embodying the invention;

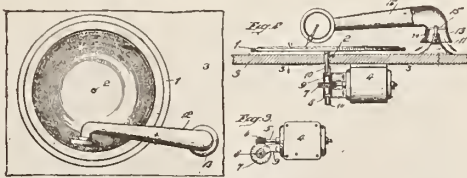

Fig. 2, a side view partly in section, and Fig. 3, a section on line 3-3 Fig. 2.

PHONOGRAPH.—Robert D. Schoonmaker, Plainfield, N. J. Patent No. 1,281,671.

The present invention relates to talking ma-

chines, and more particularly to the construction and mounting of the sound-conveying tube or tone arm employed on such machines. The main object is to provide a simple and inexpensive way of mounting a tone arm on the casing of the talking machine so as to give it the required freedom of movement in planes parallel and at right angles to the surface of the record.

Figure 1 is a side elevation, partly in section, of a tone arm constructed in accordance with

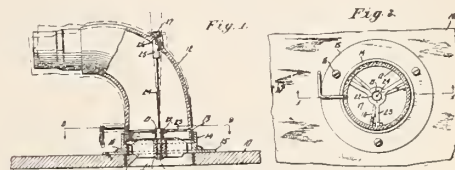

the present invention; and Fig. 2 is a section taken on line 2-2 of Fig. 1.

TONE ARM ADJUSTMENT.—Samuel Hechler, New York. Patent No. 1,282,007.

This invention relates to sound recording and reproducing instruments and has particular reference to tone arm attachments. Among the objects of the invention is to provide a simple device whereby the counter balancing effect on a tone arm may be easily varied according to various types of records that are being played and without any danger of destroying the musical effect.

Figure 1 is a perspective view of a conventional oscillating tone arm having the improvement applied thereto. Fig. 2 is a vertical sectional view indicating more particularly the re-

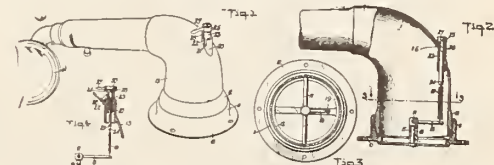

lation of the improvement to the known devices. Fig. 3 is a horizontal section on the line 3-3 of Fig. 2; and Fig. 4 is a modification of the adjustment means.

PRODUCTION OF SOUND RECORDS.—Jonas W. Aylsworth, East Orange, and Edward L. Aiken, Orange, N. J., assignors to the New Jersey Patent Co., West Orange, N. J. Patent No. 1,282,011.

This invention relates to the production of sound records; and the principal object is to provide a sound record having an improved label or other means of identification. This invention also contemplates the production of an improved matrix for forming the said record and also improved processes for making the record and the matrix. The production of an improved matrix for forming said record, referred to above, is described and claimed in copending application Serial No. 253,653, filed September 11, 1918, entitled Matrices for producing sound records, and the improved process for making sound records is described in copending application Serial No. 253,652 filed September 11, 1918, entitled Methods of producing sound records, both of which copending applications are divisions of the present case.

In accordance with the invention, we form a matrix containing a reversed facsimile of the

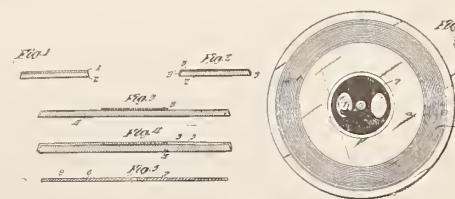

design to be reproduced on the record, this design being in half tone. When the matrix has been obtained, the same is pressed into or against the record composition, which is maintained in a plastic state during the pressing operation. The matrix preferably contains a reversed facsimile of the sound record impressions as well as of the label; so that the record and the label can be impressed into the record tablet by a

(Continued on page 116)

LATEST PATENTS RELATING TO TALKING MACHINES AND RECORDS—(Continued from page 115)

single operation. By means of a matrix formed according to the invention, a label embodying the finest design may be satisfactorily impressed into the record tablet.

In order that the invention may be more clearly understood, reference is hereby made to the accompanying drawings in which Figures 1 to 4 inclusive are cross-sectional views illustrating diagrammatically various steps performed in carrying out the invention. Fig. 5 is a central vertical sectional view of a sound record embodying the invention; and Fig. 6 is a face view of the same.

TALKING MACHINE.—Andrew Haug, New York. Patent No. 1,281,565.

This invention relates generally to talking machines and has particular reference to the construction of sound boxes for use in connection with such machines.

The primary object of the invention is to obtain better tone quality of the reproduced sound, by constructing the sound box in a manner to give it freer action and greater sensitiveness, thereby rendering it more fully responsive, particularly to the finer vibrations of the record, which are ordinarily damped out and lost in the use of sound boxes now on the market, as a result of frictional resistance and pressure on the moving parts thereof.

It has been found by experiment and test that greatly improved results are obtained in tone quality, when the diaphragm and stylus arm of the sound box are operatively connected in such relation that normally or when the sound box is not in use, no pull or pressure is exerted by the stylus arm on the diaphragm and the latter, excepting its usual circumferential mounting, is entirely free of tension.

A second important feature of the invention consists in mounting the stylus arm so that it will be firmly held against lost motion or rattling and at the same time, free to vibrate with the least possible amount of friction.

In connection with the peculiar mounting of the stylus arm, an additional and even more important feature of the invention consists in the

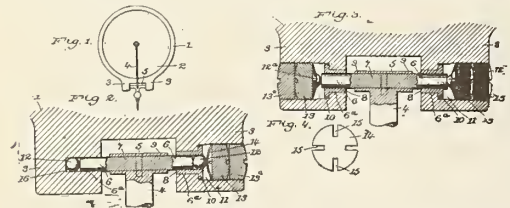

provision of means for varying the pressure between the pivotal centers on which the stylus arm turns, to "tune" the sound box. That is to say, by increasing the pressure, the pitch of the box is raised and on reducing the pressure, the pitch is lowered. The important resulting advantages will be apparent.

Figure 1 is a face view of the sound box. Fig. 2 is a sectional view taken horizontally through the pivotal centers on which the stylus arm vibrates. Fig. 3 is a similar view of a slightly modified form, and Fig. 4 is a detail view of the spring disc shown in Fig. 2.

AMPLIFIER FOR TALKING MACHINES.—Joseph Wolff, Brooklyn, N. Y., assignor to the Sonora Phonograph Co., New York. Patent No. 1,283,007.

This invention relates to a sound amplifier for talking machines, and more particularly to such type of talking machines in which the amplifier is concealed within the cabinet containing the operative parts of the mechanism.

The object of the invention is to produce an amplifier, by means of which the purity and sweetness of the reproduced sound will be increased, and the reproduced sound will be a true reproduction of the sound as recorded.

Another object of the invention is to provide improvements in a sound amplifying device for recording or reproducing sound, by means of which the quality and naturalness of the sounds are recorded or reproduced with greater faithfulness and a more true reproduction of the original.

Figure 1 is a rear elevation of a wooden horn provided with the invention; Fig. 2 is a side elevation of the same; Fig. 3 is a side elevation showing a modification; Figs. 4 and 5 are views similar to Figs. 1 and 2, but showing a further

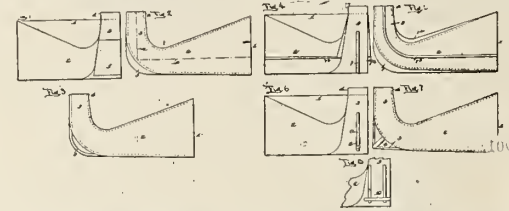

modification; Figs. 6 and 7 are similar views of a still further modification; Fig. 8 is a fragmentary rear elevation showing a still further modification.

SOUND-REPRODUCING MACHINE.—Hobart C. Niblack, Rochester, N. Y., assignor to Emanuel L. Miller, Cincinnati, O. Patent No. 1,282,916.

This invention relates to improvements in sound reproducing machines, with more particular reference to disc or flat record graphophones, and it has for its primary purpose to provide a novel construction and arrangement of parts for automatically effecting one or more repetitions of a record, and also for stopping movement of the record at the end of a plurality of complete operations.

Figure 1 is a plan view, showing the application of the invention to a flat record sound reproducing machine, with parts broken away, the

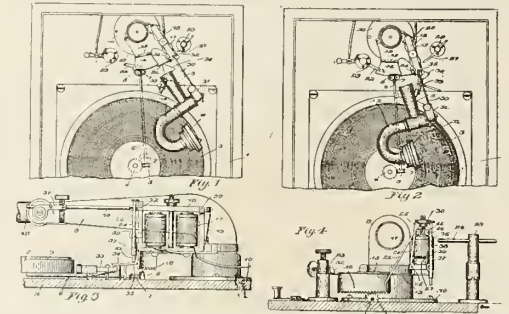

sound box appearing at the starting point on the record; Fig. 2 is a similar view, showing the position of the parts when the sound box is at the end of its movement on the record, and about to be lifted and carried back to its starting point; Fig. 3 is a side elevation of the repeating mechanism, and Fig. 4 is a vertical sectional view with parts in elevation.

PHONOGRAPH REPRODUCER.—Archie E. Parnell, Chicago, Ill., assignor to Frank W. Williams, same place. Patent No. 1,284,136.

This invention relates to an improved form of a phonograph reproducer wherein the inner end of the stylus arm is adapted to be securely fastened to the exact center of the diaphragm, by means of a resilient member secured between the diaphragm and the reproducer casing.

It is an object of this invention to produce a phonograph reproducer in which the diaphragm and the stylus arm are formed to insure exact centering of the inner end of the stylus arm with respect to the diaphragm.

It is also an object to construct a phonograph sound box having a grooved gasket member adapted to hold a centrally apertured diaphragm exactly in the center of the sound box to permit the inner hooked end of a stylus arm to be securely fastened directly in the center of said diaphragm.

It is furthermore an object to construct a phonograph reproducer wherein the diaphragm is held exactly in the center of the reproducer to permit the inner end of a stylus arm to be secured exactly in the center of the diaphragm.

It is an important object of the invention to produce a phonograph reproducer of simple and effective construction wherein the stylus arm is insured of being attached to the center of the diaphragm.

Figure 1 is a central vertical section taken through a phonograph reproducer embodying the principles of the invention, with parts shown in elevation. Fig. 2 is a bottom plan view

thereof. Fig. 3 is an enlarged detail section taken on line 3—3 of Fig. 2, with parts broken away. Fig. 4 is a central vertical section of the reproducer diaphragm and its supporting and centering means. Fig. 5 is an enlarged fragmentary vertical section taken through the central portion of the diaphragm showing the inner end of the stylus arm partly engaged in the central aperture of said diaphragm. Fig. 6 is

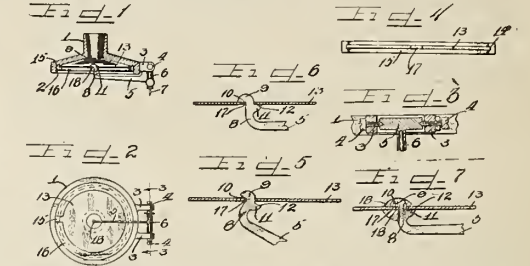

a similar section showing the next step in the operation. Fig. 7 is a similar view showing the stylus arm secured to the center of the diaphragm.

PHONOGRAPH.—Newman H. Holland, West Orange, N. J., assignor to the New Jersey Patent Corp., same place. Patent No. 1,283,771.

This invention relates to phonographs and more particularly to such phonographs as are suitable both for recording and for reproducing sound waves.

The principal object of the invention is to provide an improved device of this character in which a single sound box is provided with both a recording stylus and a reproducing stylus, the styli being preferably so mounted that the reproducer stylus is movable laterally when in operative position to permit the same to readily follow the record groove regardless of the lateral irregularities therein, whereas the recording stylus is firmly held against lateral movement when in operative position. The means for holding the recording stylus against lateral movement are preferably thrown into operation automatically when said stylus is moved into operative position. A further object of the invention is to provide the sound box with an improved device arranged to track the record blank when the recording stylus is in operative position so as to take part of the weight of the sound box off the stylus, this device being inoperative when the reproducer stylus is in position for engagement with the record and thereby permitting the full downward pressure of the sound box to hold the reproducer stylus in engagement with the record.

Figure 1 is a view partly in section and partly in side elevation of a phonograph embodying one form of the invention, the reproducing stylus being shown in operative position; Fig. 2 is a view similar to that of Fig. 1, but taken from

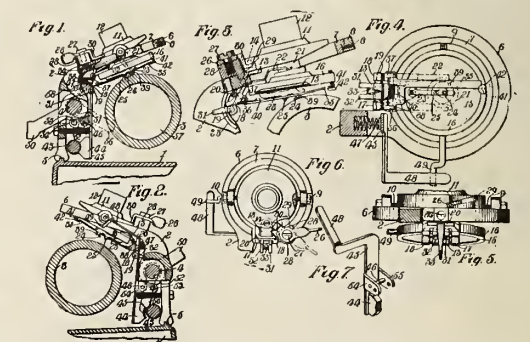

the opposite end of the phonograph and showing both styli in elevated or inoperative position; Fig. 3 is an enlarged view partly in side elevation and partly in section of a part of the apparatus shown in Fig. 1, the recording stylus being shown in operative position; Fig. 4 is a bottom plan view of the device shown in Fig. 3, the record cylinder being omitted; Fig. 5 is a rear elevation of the device shown in Fig. 3 with some of the parts omitted or broken away; Fig. 6 is a top plan view partly in section of the greater part of the apparatus shown in Fig. 1; and Fig. 7 is a perspective view of a detail of construction.

RECORD BULLETINS FOR JANUARY, 1919

VICTOR TALKING MACHINE CO.

POPULAR SONGS

- 18508 Dreaming of Home, Sweet Home, Charles Harrison 10
The Rose of No Man's Land, Charles Hart-Elliott Shaw 10
18509 After You've Gone, Marion Harris 10
I'm Glad I Can Make You Cry, Henry Burr 10
18510 When Tony Goes Over the Top, Billy Murray 10
Good Morning, Mr. Zip-Zip-Zip, Arthur Fields and Peerless Quartet 10
18499 Waters of Venice-Waltz, Violin and accordion, Bernie and Baker 10
Good-Bye, Alexander-Fox-trot, Violin and accordion, Bernie and Baker 10
18500 Mary-Fox-trot, Joseph C. Smith's Orchestra 10
Rock-a-Bye Baby-Fox-trot, Joseph C. Smith's Orchestra 10
45156 A Little Birch Canoe and You, Olive Kline and Orpheus Quartet 10
The Bluebird, Elsie Baker 10
45157 The Americans Come!, Reinald Werrenrath 10
I Can Always Find a Little Sunshine in the Y. M. C. A., Lambert Murphy and Orpheus Quartet 10
55092 Sounds of the Forest, Part I, Charles Kellogg 12
Sounds of the Forest, Part II, Charles Kellogg 12
RED SEAL RECORDS
FRANCES ALDA, Soprano-SOPHIE BRASLAW, Contralto In Italian
88597 Madam Butterfly-Tutti i fior (Duet of the Flowers) (Act 2), Puccini 12
FRANCES ALDA, Soprano-GIOVANNI MARTINELLI, Tenor In Italian
88598 La Bohème-O soave fanciulla (Thou Sweetest Maiden), Puccini 12
ENRICO CARUSO, Tenor-In Italian
87297 Garibaldi's Hymn, Mercantini-Olivieri
ELMAN STRING QUARTET
(Mischa Elman and Messrs. Bak, Rissland and Nagel of Boston Symphony Orchestra)
74575 Andante Cantabile (From String Quartet, Op. 11), Tchaikowsky 12
ALMA GLUCK, Soprano-EFREM ZIMBALIST, Violinist In Hebrew
87296 Hatikva ("Our Hope"), Zionist Hymn 10
JOHN McCORMACK, Tenor
64791 When You Come Back, George M. Cohan 10
ERNESTINE SCHUMANN-HEINK, Contralto
87298 Onward, Christian Soldiers, Baring-Gould-Sullivan 10

COLUMBIA GRAPHOPHONE CO.

- 49449*Caprice Viennois (Kreisler, Opus 2), Toscha Seidel 12
49447*Romance from Concerto No. 2 (Wieniawski, Opus 22), Toscha Seidel 12
78097*O Sole Mio! (My Sun), Riccardo Stracciari 10
77719*Songs My Mother Taught Me, Hilda Lashanska 10
INSTRUMENTAL GEMS
A2653*Hungarian Dance No. 5 in G Minor, Philharmonic Orchestra of New York 10
Hungarian Dance No. 6 in D Major, Philharmonic Orchestra of New York 10
A6080 A Roman Carnival-Overture-Part I, Columbia Symphony Orchestra 12
A Roman Carnival-Overture-Part II, Columbia Symphony Orchestra 12
A6078 Rondo Capriccioso, Josef Hofmann 12
Berceuse, Josef Hofmann 12
A2654 The Whistler and His Dog, Prince's Band 10
The Warbler's Serenade, Prince's Band 10
A2650 The Lost Chord, Edna White Trumpet Quartet 10
Nearer, My God, to Thee, Edna White Trumpet Quartet 10
A2651 On the Banks of the Wabash Far Away-Medley, Intro.: (1) "My Gal Sal," (2) "When You and I Were Young, Maggie," Joseph Green, Xylophone 10
A Bunch of Roses, George Hamilton Green, Xylophone 10
GEMS FROM CATALOGS OF FOREIGN LANGUAGE RECORDS
E4060 Naval Cadets March, Bell Solo with Band Accomp. 10
Albinos Polka, Xylophone Solo, Band Accomp. 10
A2660 Oh, How She Could Spanish, Irving Kaufman 10
I Want a Doll, Irving Kaufman 10
A2659 Merrily We'll Roll Along, Peerless Quartet 10
Everything Is Hunky Dory Down in Honky Tonky Town, Peerless Quartet 10
A2658 On the Level You're a Little Devil (But I'll Soon Make an Angel Out of You), Irene Farber and Lewis James 10
Any Old Time at All, from "Ziegfeld Follies 1918", Peerless Quartet 10
A2662*Mickey, Sterling Trio 10
Mickey, Prince's Orchestra 10
A2664 Come Along to Toy Town, from "Everything," Peerless Quartet 10
The Monkey-Man, Lewis James 10
A2661 Hindustan, Campbell and Burr 10
In the Shadow of the Desert Palm, Sterling Trio 10
A2648 Ostrich Walk-Fox-trot, Guido Deiro 10
Jazz Band Ball-One-step, Guido Deiro 10
A2663 Has Anybody Seen My Corinne?-Medley Fox-trot, Intro.: (1) "Down on Bull Frog's Isle," (2) "Livery Stable Blues," Wilbur Sweatman's Original Jazz Band 10
Dallas Blues-Medley Fox-trot, Intro.: (1) "At the Funny Page Ball," (2) "Lovin' (I Can't Live Without It)," Wilbur Sweatman's Original Jazz Band 10
A6079 On the Level You're a Little Devil-Medley Fox-trot, Prince's Band 12
What Yankee Doodle Says He'll Do, He'll Do-Medley One-step, Prince's Band 12
DECEMBER MID-MONTH LIST ON SALE DECEMBER 10
These are the regular January records which go on sale December 10 and will go on sale again December Watch your supplies of these popular numbers.
A2657*Tell That to the Marines, Arthur Fields 10
You Can't Beat Us, Arthur Fields 10
A2655*A Little Birch Canoe and You, Sterling Trio 10
Light Your Little Lamp of Love for Me, Campbell and Burr 10
A2652*O Death, Where Is Thy Sting?..Bert Williams 10
When I Return, Bert Williams 10
A2656 O How I Wish I Could Sleep (Until My Daddy Comes Home), Henry Burr 10
Watch, Hope and Wait, Little Girl (Till I Come Back to You), Sterling Trio 10
A2647* I Can Always Find a Little Sunshine in the Y. M. C. A., from "Yip Yip Yaphank," Peerless Quartet 10
Ding Dong, from "Yip Yip Yaphank," Peerless Quartet 10

- A6082*Massa's in de Cold, Cold Ground, Oscar Seagle and Columbia Stellar Quartet 12
Old Folks at Home, Oscar Seagle and Columbia Stellar Quartet 12
A6081*My Belgian Rose-Medley Waltz, Intro.: "I'm Sorry I Made You Cry," Prince's Orchestra 12
Beautiful Ohio-Waltz, Prince's Orchestra 12
A2649* Russian Rag Fox-trot, Earl Fuller's Rector Novelty Orchestra 12
Howdy, Earl Fuller's Rector Novelty Orchestra 10

EDISON AMBEROL RECORDS

- ROYAL PURPLE RECORD
5 Mira, di acerbe lagrime-Il Trovatore (Let my tears implore thee), (Verdi), Soprano and haritone, in Italian, orch. accomp., Marie Rappold and Taurino Parvis
REGULAR LIST
3628 Romance sans paroles (Ch. Davidoff), Op. 23, Violoncello, orch. accomp., Vladimir Duhinsky
3643 Keep the Home-Fires Burning (Ivor Novello), 1st soprano, 2d soprano and alto, orch. accomp., Homestead Trio
3629 Barcarole-The Tales of Hoffmann (Offenbach), Creator and His Band
3631 God Be With Our Boys To-night (Wilfrid Sanderson), Mixed voices, orch. accomp., Metropolitan Quartet
3633 Just a Baby's Prayer at Twilight (M. K. Jerome), Violin, pianoforte by John F. Burkhardt, Herbert Soman
3632 Soldier Songs, No. 1, Chorus of Male Voices
3625 Mother, My Dear (Bryceson Treharne), Tenor, orch. accomp., Ralph Errolle
3623 I'm Waiting For You, Liza Jane (Creamer-Layton), Orch. accomp., Arthur Collins and Byron G. Harlan
3622 Oriental-Fox-trot (Vincent Rose), For dancing, Jaudas' Society Orchestra
3626 Garden of My Dreams (Stamper-Hirsch), Soprano and tenor, orch. accomp., Gladys Rice, Vernon Dalhart and Chorus
3627 Yock-A-Hilo Town (Walter Donaldson), Tenor, orch. accomp., Vernon Dalhart
3634 Mandy-Yip-Yip-Yaphank (Irving Berlin), Tenor and male voices, orch. accomp., Billy Murray and Chorus
3630 If I'm Not at the Roll-Call, Kiss Mother "Good-Bye" For Me (George Boyden), Tenor, orch. accomp., Harvey Wilson
3635 When I Gets Out in No-Man's Land (I Can't Be Bother'd With No Mule) (Skidmore-Walker), Negro song, orch. accomp., Arthur Collins
3624 Just Blue-Fox-trot (Wadsworth-Arden), Saxophone-xylophone and piano, for dancing, All Star Trio
3639 Oh! How I Hate to Get Up in the Morning (Irving Berlin), Baritone, orch. accomp., Arthur Fields
3636 The Y. M. C. A.-Yip-Yap-Yaphank (Irving Berlin), Tenor and male voices, orch. accomp., George Wilton Ballard and Chorus
3641 Tell That to the Marines (Schwartz-Jolson), Tenor and male voices, orch. accomp., Billy Murray and Chorus
3642 I Ain't Got Weary Yet (Percy Wenrich), Baritone and male voices, orch. accomp., Arthur Fields and Chorus
3446 Kohala March, Instrumental trio, Ford Hawaiians
3505 A Little Bit of Sunshine (From Home) (Hanley), Tenor, Vernon Dalhart
3540 Day by Day the Manna Fell (Gotschalk), Contralto, Nevada Van der Veer
2844 Lorna (Newton), Tenor, Emory B. Randolph
2860 Recitatif et Cavatine, "Sous les pieds d'une femme"-La Reine de Saba (Gounod), Basso, in French, T. Foster Why
2996 In a Dusty Caravan (Gilbert-Lee), Tenor, Walter Van Brunt
3039 Poor Butterfly-New York Hippodrome-"The Big Show" (Hubbell), Soprano, Elizabeth Spencer
3088 Go Get 'Em-One-step (Manholz), For dancing, Jaudas' Society Orchestra
3096 In the Clock Store-Descriptive Fantasia (Orth), Sodero's Band
3217 I've Got the Sweetest Girl in Maryland (Donaldson), Male voices, Premier Quartet
3376 Divertimento-II Convegno (Ponchielli), Clarinets, Antonio Giammatteo and Fred J. Brissett
3451 Silver Threads Among the Gold (Danks), Soprano, Elizabeth Spencer and Chorus

EDISON RE-CREATIONS

- 80413 Silver Bay (Percy Wenrich), Mixed Voices, Metropolitan Quartet
Sweet Hawaiian Moonlight (Tell Her of My Love) (F. Henri Kluckmann), Soprano and Contralto, Gladys Rice and Marion Evelyn Cox
80414 Anchored! (Michael Watson), Baritone, Thomas Chalmers
Land of the Long Ago (Lilian Ray), Tenor, Charles Harrison
80416 Church in the Wildwood (Dr. Wm. S. Pitts), Male Voices, Apollo Quartet of Boston
Ninety and Nine (Ira D. Sankey), Contralto, Christine Miller
50478 Colored Recruits, Billy Golden and Billy Heins
Whistling Coon (Sam Devere), Edward Meeker and Empire Vaudeville Co.
83077 Synnove's Song (Kjerulf), Soprano, Anna Case
Will o' the Wisp; and That's the World in June (Spross), Soprano, Anna Case
82547 Infelice! e tu credevi (Unhappy One!)-Ernani (Verdi), Basso, in Italian, Virgilio Lazzari
O casto fior del mio sospir-Re di Lahore (Massenet), Baritone in Italian, Taurino Parvis
82130 The Captive (Edouard Lalo), Until (Wilfrid Sanderson), Contralto, Caroline Lazzari
Two Roses (Hallett Gilberte), Contralto, Caroline Lazzari
80412 Cleopatra Polka (E. Demare), Cornet, Bohumir Kryl
Egyptia (Characteristic Intermezzo) (V. S. Zamecnik), Peerless Quartet
50484 Doughtie the Baker (Harry Lauder), Glen Ellison
Wec Deoch and Doris (Grafton-Lauder), Glen Ellison
Nation's Awakening March (Lucien Denni), New York Military Band
Volunteers March (Sousa), New York Military Band
50487 In the Clock Store-Descriptive Fantasia (Chas. J. Orth), Sodero's Band
Nightingale and the Frog (Eilenberg), Piccolo and Bassoon, Weyert A. Moor and Benjamin Kohon
50488 Rag-a-Minor-One-step (Julius Lenzberg), Jazarrimha Orchestra
Watermelon Whispers Fox-trot (Green), Xylophone, George Hamilton Green

PATHE FRERES PHONOGRAPH CO.

- 22005*I Can Always Find a Little Sunshine in the Y. M. C. A., from "Yip Yip Yaphank" (Berlin), Invinchile Four
Ding, Dong, from "Yip Yip Yaphank" (Berlin), Invinchile Four
22006*Come Along to Toy Town, from "Everything," N. Y. Hippodrome Show (Berlin), Henry Burr and Chorus
Where It's Peach Jam Makin' Time (Kendus-Brockman-Vincent), Collins and Harlan
22007*An Irishman Was Made to Love and Fight (Santly), Arthur Fields, Baritone
I Ain't Got Weary Yet (Wenrich), Arthur Fields, Baritone
22004*Oh! How I Wish I Could Sleep Until My Daddy Comes Home (Wending), Harry McClaskey, Tenor
The Trail of the Lonesome Pine (Carroll), Harry McClaskey, Tenor, with Invinchile Four
29222*Waiting for You, from "The Maid of the Mountains" (Lieut. Gitz Rice), Lewis James, Tenor
Dear Little Boy of Mine (Ball), Irving Gillette, Tenor
NEW PATHE "DE LUXE" DANCE RECORDS
22008*Kentucky Dreams (Henry-Onivas)-Waltz, American Republic Band
10
Mary (Frey)-Fox-trot, American Republic Band
10
22009*There's Life in the Old Dog Yet (Carroll)-Fox-trot, American Republic Band
10
Me-ow (Kaufman)-One-step, American Republic Band
10
29223*Feist "Hit Medley," Intro.: (1) "Everything Is Peaches Down in Georgia," (2) "I'm Sorry I Made You Cry," (3) "K-K-Katie," (4) "Mr. Zip, Zip Zip,"-Fox-trot, American Republic Band
12
Fu (Howard)-One step, American Republic Band
12
STANDARD BALLADS SUNG IN ENGLISH
25021 Neath the Autumn Moon (Vanderpool), Grace Hoffman, Soprano
10
The Madcap (Marchesi), Grace Hoffman, Soprano
10
29224 Daddy (Behrend), Helen Clark, Contralto
12
Fiddle and I (Goodeye), Helen Clark, Contralto, Violin Obligato
12
29203 Sussex by the Sea (Ward-Higgs), Frank Oldfield, with Peerless Quartet
12
Be British (Shuttleworth), Frank Oldfield, Baritone
12
22003 Mother, My Dear (Treharne), William Simmons, Baritone
10
Love Me or Not (Secchi), William Simmons, Baritone
10
22010 Sweet and Low (Barnhy), Big City Four, Unaccomp.
10
Rose Marie (Molloy), Lewis James, Tenor
10
NEW BAND AND ORCHESTRA RECORDS
40143 Finlandia, Part I (Sibelius), Tone Poem, Pathé Military Band
12
Finlandia, Part II (Sibelius), Tone Poem, Pathé Military Band
12
22013 Anvil Polka (Parlow), with Anvil Effects, American Regimental Band
10
The Whistler and His Dog (Pryor), with Whistling Effects, American Regimental Band
10
22014 Flags of Freedom (Sousa)-March, American Regimental Band
10
Solid Men to the Front (Sousa)-March, American Regimental Band
10
22015 Valse Mai (Godin)-Waltz, Imperial Symphony Orchestra
10
Valse d'Avril (Godin)-Waltz, Imperial Symphony Orchestra
10
NEW INSTRUMENTAL NOVELTIES
59063 Fruhlingsrauschen (Voices of Spring) (Sinding), Piano Solo, Rudolph Ganz
12
5th Mazurka in A (Godard)-Piano Solo, Rudolph Ganz
12
22011 Forsaken (Fitzhugh from "Koschat"), Haydn Brass Quartet
10
Hungarian Selections-"Medley," Ernest Hussar's String Sextet
10
25019 Polichinelle (Kreisler) "Serenade"-Violin Solo, Emily Gresser, Piano Accomp.
10
Mazurka in A Minor (Chopin-Kreisler)-Violin Solo, Emily Gresser, Piano Accomp.
10
22012 The Nightingale (Boccaccio)-Ocarina Solo, José Valdean, Piano Accomp.
10
The Turtle Dove (Demare)-Ocarina Solo, José Valdean, Piano Accomp.
10
NEW OPERATIC VOCAL RECORDS
27509 Il Trovatore (Verdi), "Home to Our Mountains," Kathleen Howard, Contralto, and Paul Althouse, Tenor
10
Faust (Gounod), "When All Was Young," Kathleen Howard, Contralto
10
54022 La Traviata (Verdi), "Addio del passato" (Farewell to the Bright Visions)-In Italian, Claudia Muzio, Soprano
12
54014 Manon (Massenet), "Le Reve," (The Dream)-In French, Lucien Muratore, Tenor
12
54005 Carmen (Bizet), "Air de la Fleur" (Flower Song)-In French, Lucien Muratore, Tenor
12
All records in this list marked with a star () are for immediate release.

STARR PIANO CO.

- ART TONE RECORDS
15003 Famous Variations (Proch), Sung in Italian, col. sop., accomp. by Florida's Concert Orch., Mme. Nadina Legat
Swiss Echo Song (Echert), Sung in French, col. sop., accomp. by Florida's Concert Orch., Mme. Nadina Legat
8531 Those Songs My Mother Used to Sing (H. Wakefield Smith), Tenor with orch. accomp., Harry McClaskey
The Sweetest Story Ever Told (R. M. Stuits), Soprano with orch. accomp., Tonika Frese
11010 Aloha Oe (Farewell to Thee), Cornet solo, accomp. by Dantz's Concert Band, Pietro Capodifero
Coronation March (G. Meyerbeer), Dantz's Concert Band, Dante himself conducting
8532 Cohen Telephones the Gas Company, Comic monologue, Geo. Thompson
Cohen in a Restaurant, Comic monologue, Geo. Thompson
11011 Berceuse from "Jocelyn" (Hoffman), Violinist-Gaaragusi, Piano-Longo, Flute-Laucella, Gennett Trio
Tales of Hoffman-Intermezzo Elegante (Les Contes D'Hoffman) (J. Offenbach), Gennett Trio
8533 Wee Wee, Marie, Arthur Hall
I Ain't Got Weary Yet, Arthur Fields
8534 The Rose of No Man's Land, Henry Burr
Oh! How I Wish I Could Sleep Until My Daddy Comes Home, Henry Burr
11012 Some Lonesome Night Medley-Fox-trot Medley, Cody's Band
When You Come Back Medley-One-step Medley, Gennett Band
8553 Everything Is Peaches Down in Georgia (Ager and Meyer), Conklin's Novelty Orchestra
Motor Boat One-step, (Conducted by the composer), Italian Dance Orchestra
(Continued on page 118)

RECORD BULLETINS FOR JANUARY

(Continued from page 113)

N. Y. RECORDING LABORATORIES

LATE POPULAR SONGS

- 30078 A Khaki Lad—Baritone Solo.....Royal Dadmun
- Ring Out, Liberty Bell—Baritone Solo.....Royal Dadmun
- 30081 The Rose of No Man's Land—Tenor Solo,

Henry Burr

A Little Birch Canoe and You—Vocal,

Sterling Trio

A WONDERFUL DANCE RECORD

- 30082 I'm Sorry I Made You Cry—Medley Waltz. In-
- tro. My Belgian Rose.....W. Roger's Band
- Cocoanut Grove—Fox-trot.

Blondell Saxophone Quartet

- 30080 Blue Bird Waltz—Whistling Solo, orch. accomp.

Sibyl Sanderson Fagan

The Boy and the Birds—Whistling Solo, orch.

accomp.....Sibyl Sanderson Fagan

PIANO, XYLOPHONE, VIOLIN AND TRIO RECORDS

- 30079 Prelude (Rachmaninoff)—Piano Solo,

Beryl Rubenstein

Kamennoi (Ostrow-Mendelsohn)—Piano Solo,

Beryl Rubenstein

- 30084 My Old Kentucky Home—Violin Solo,

Samuel Gardner

Believe Me If All Those Endearing Young

Charms—Violin, 'Cello and Piano.

Gondolier Trio

- 30083 The Rosary—Violin, 'Cello and Piano....Thiele Trio
- Ave Maria—Xylophone Solo....George Hamilton Green

EMERSON PHONOGRAPH CO.

The New Large-Size Gold Seal Records

PATRIOTIC AND POPULAR HITS OF THE DAY

- 9103 The Rose of No Man's Land (Caddigan-Bren-
- nan). Tenor duet, orch. accomp.,

George Gordon and Robert Bruce

Some Day Waiting Will End (Wodehouse-

Caryll). Tenor solo, orch. accomp....Henry Burr

- 9102 I'm Glad I Can Make You Cry (McCarron-
- Morgan). Tenor Solo, orch. accomp.,

George Gordon

The Pickaninnies' Paradise (Ehrlich-Osborne).

Baritone and tenor duet, orch. accomp.,

Jack and Phil Kaufman

- 9109 Till We Meet Again (Egan-Whiting). Tenor
- duet, orch. accomp.....Burr and Campbell

A Little Birch Canoe and You (Callahan-Rob-

erts). Vocal trio, orch. accomp....Sterling Trio

- 995 Tell That to the Marines (Schwartz-Jolson).

Baritone solo, orch. accomp....Irving Kaufman

Why Do They Call Them Babies When They

Mean Grown-Up Ladies? (Harriman-Egan).

Contralto solo, orch. accomp.....Edith King

- 9110 Oh! Susie, Behave (Rose-Olman). Character
- song, orch. accomp.....Eddie Nelson

I Love Her and She Loves Me (Rose-Glogau).

Character song, orch. accomp.....Eddie Nelson

- 996 I Ain't Got Weary Yet (Johnson-Wenrich).

Baritone solo, orch. accomp.....Arthur Fields

Belinda Open Up Your Window (McCarron-

Morgan). Character song, orch. accomp.,

Irving Kaufman

- 997 Oh! How I Wish I Could Sleep Until My
- Daddy Comes Home (Lewis-Young-Wendling).

Patriotic ballad, orch. accomp.....Henry Burr

Watch, Hope and Wait, Little Girl, Till I Come

Back to You (Brown-Clayton). Vocal duet,

orch. accomp....George Gordon and Robert Bruce

- 9104 When Tony Goes Over the Top (Marr-Frisch-
- Fletcher). Character song, orch. accomp.,

Arthur Collins

He's Well Worth Waiting For (Kilgour-Von

Tilzer). Baritone solo, orch. accomp....Greek Evans

- 998 Don't You Remember the Day? (Cliff, Hess).

Baritone solo, orch. accomp.....Eddie Nelson

My Friends, Morris and Max (Halman-Leslie-

Ruby). Character song, orch. accomp.,

George L. Thompson

- 9105 Everything Is Hunky Dory Down in Honky
- Tonky Town (McCarthy-Tierney). Vocal

duet, orch. accomp.....Collins and Harlan

Coming Through the Rhine (Fields-Donovan).

- Baritone solo, orch. accomp.....Arthur Fields
- 999 Departure of American Troops for France (Fred
- Hager). Descriptive Vocal Quartet, accomp.
- by Emerson Military Band..Peerless Male Quartet
- Arrival of American Troops in France (Fred
- Hager). Descriptive Vocal Quartet, accomp.
- by Emerson Military Band..Peerless Male Quartet
- 9106 Trinity Chimes Auld Lang Syne...Chimes and Organ
- Trinity Chimes Come All Ye Faithful (Adeste
- Fideles).....Chimes and Organ

LATEST DANCE RECORDS

- 9100 Mary (Stoddard-Frey)—Fox-trot,

Emerson Military Band

I Want a Doll Medley (Von Tilzer)—One-step,

Emerson Military Band

- 9107 Russian Rag (Geo. L. Cobb) ("Prelude" by
- Rachmaninoff)—One-step...Emerson Military Band

Devil's Dance (Eugene Ratzmann)—Fox-trot,

Emerson Military Band

STANDARD SELECTIONS

- 9108 I Love You Truly (Carrie Jacobs-Bond). Con-
- tralto solo, accomp. by piano and violin,

Alice Louise Mertens

Good bye, Sweet Day (Kate Vannah). Contralto

solo, accomp. by piano and violin,

Alice Louise Mertens

- 9101 Polish Dance No. 1 (A. Schwarwonka),

Emerson Military Band

Bolero Spanish Dance (Moszkowski),

Emerson Military Band

EMERSON PHONOGRAPH CO.

The New Seven-Inch Records

PATRIOTIC AND POPULAR HITS OF THE DAY

- 7429 Till We Meet Again (Egan-Whiting). Tenor
- duet, orch. accomp.....Rice and Rhodes

Silver Threads Among the Gold (H. P. Danks).

Vocal quartet.....Liberty Quartet

- 7430 I'm Glad I Can Make You Cry (McCarron-
- Morgan). Tenor solo, orch. accomp.,

George Gordon

Oh Death, Where Is Thy Sting? (Clarence A.

Stout). Baritone solo, orch. accomp.,

Ernest Hare

- 7431 The Rose of No Man's Land (Caddigan-Bren-
- nan). Tenor duet, orch. accomp....Gordon & Bruce

Tell Me Why You Went Away (Edna Alexan-

der). Baritone solo, orch. accomp....George Beaver

- 7432 I Ain't Got Weary Yet (Johnson-Wenrich).

Character song, orch. accomp.....D. Bud Bernie

Everything Is Hunky Dory Down in Honky

Tonky Town (McCarthy-Tierney). Character

song, orch. accomp.....Collins and Harlan

- 7433 A Little Birch Canoe and You (Callahan-Rob-
- erts). Vocal trio, orch. accomp....Sterling Trio

Some Day Waiting Will End (Wodehouse-

Caryll). Tenor solo, orch. accomp....Robert Rice

- 7434 Watch, Hope and Wait, Little Girl, Till I Come
- Back to You (Brown-Clayton). Tenor duet,

orch. accomp.....Gordon and Bruce

He's Well Worth Waiting for (Kilgour-Von

Tilzer). Baritone solo, orch. accomp....Harry Evans

- 7435 Oh! Susie, Behave (Rose-Olman). Character
- song, orch. accomp.....Eddie Nelson

Why Do They Call Them Babies When They

Mean Grown-Up Ladies? (Harriman-Egan).

Contralto solo, orch. accomp.....Edith King

- 7436 I Love Her and She Loves Me (Rose-Glogau).

Character song, orch. accomp.....Eddie Nelson

Belinda, Open Up Your Window (McCarron-Mor-

gan). Character song, orch. accomp....George Beaver

- 7437 Coming Through the Rhine (Fields-Donovan).

Baritone solo, orch. accomp.....D. Bud Bernie

We'll Put the Kibosh on the High Boche

(Brooks-Hill). Baritone solo, orch. accomp.,

Harry Evans

DANCE SELECTIONS

- 7438 I Want a Doll Medley (Von Tilzer)—One-step,

Emerson Military Band

Devil's Dance (Eugene Ratzmann)—Fox-trot,

Emerson Military Band

- 7439 Arabian Nights (David-Hewitt)—Intermezzo
- One-step.....Emerson Military Band

Parisian Rag (Branan-Lange)—Fox-trot,

Emerson Military Band

- 7440 Flags of Freedom (Lieut. John Phillip Sousa)—
- March.....Emerson Military Band

Skip-a-Long Blues (W. T. Carroll)—Fox-trot,

Emerson Military Band

OFFER SALES HELPS FOR DEALERS

A Feature of Paramount Record Service That Appeals to the Retailer

Dealers in Paramount records are finding that the handling of this line is made much easier for them through the co-operation of the New York recording laboratories in providing dealers' sales helps, the advertising department being steadily at work in devising new means of setting forth the attractive features of their records and helping the dealer keep his name and his product before the public. These new sales helps include a special set of four movie slides in striking design in Paramount green and black. The slides are carefully designed to show up well on the screen, and on each one is left space for the insertion of the dealer's name. They are furnished the dealers without charge.

OPEN TALKER DEPARTMENT

J. W. Lawrence & Sons, Winchester, Ky., have recently opened a new talking machine department, handling Claxtonola phonographs and Emerson records.

The block contains four movie slides for Paramount Records. Slide 1: 'Moonlight Waltz' featuring a marimba record, with a 'Your Name Here' label. Slide 2: 'Aloha Land and O Sole Mio' featuring Hawaiian selections, with a 'Dealer's Name Here' label. Slide 3: 'Have You Heard the New' featuring movie slides, with a 'Dealer's Name' label. Slide 4: 'December Records Now Ready' listing records like 'Smiles' and 'K.K. Katy', with a 'Dealer's Name' label.

How Dealers Are Helped to Sell Paramount Records



Where Dealers May Secure

COLUMBIA

Product

Ready, Full Stocks, and Prompt Deliveries from Convenient Shipping Centers all over the United States.

Distributors

- Atlanta, Ga., Columbia Graphophone Co., 63 N. Pryor St.
- Baltimore, Md., Columbia Graphophone Co., 16 South Howard St.
- Boston, Columbia Graphophone Co., 137 Federal St.
- Buffalo, N. Y., Columbia Graphophone Co., 737 Main St.
- Chicago, Ill., Columbia Graphophone Co., 14 N. Michigan Ave.
- Cincinnati, O., Columbia Graphophone Co., 427-429 W. Fourth Ave.
- Cleveland, O., Columbia Graphophone Co., 1376 Euclid Ave.
- Dallas, Tex., Columbia Graphophone Co., 1011 Elm St.
- Denver, Colo., Columbia Stores Co., 1608 Glen-aron Place.
- Detroit, Mich., Columbia Graphophone Co., 401 Woodward Ave.
- Indianapolis, Ind., Columbia Graphophone Co., 207-217 W. Washington St.
- Kansas City, Mo., Columbia Graphophone Co., 1027 McGee St.
- Los Angeles, Cal., Columbia Graphophone Co., 745 S. Broadway.
- Minneapolis, Minn., Columbia Graphophone Co., 412-414 Nicollet Ave.
- New Haven, Conn., Columbia Graphophone Co., 206 Meadow St.
- New Orleans, La., Columbia Graphophone Co., 517-525 Canal St.
- New York City, Columbia Graphophone Co., 55 Warren St.
- Omaha, Neb., Schmoller & Mueller Piano Co.
- Philadelphia, Pa., Columbia Graphophone Co., 210 N. Broad St.
- Pittsburgh, Columbia Graphophone Co., 632-640 Duquesne Way.
- Portland, Me., Columbia Graphophone Co., 43 Exchange St.
- Portland, Ore., Columbia Graphophone Co., 429-431 Washington St.
- Salt Lake City, Utah, Columbia Stores Co., 221 South West Temple.
- San Francisco, Cal., Columbia Graphophone Co., 130-150 Sutter St.
- Seattle, Wash., Columbia Graphophone Co., 911 Western Ave.
- Spokane, Wash., Columbia Stores Co., 818 Sprague Ave.
- St. Louis, Mo., Columbia Graphophone Co., 1127 Pine St.
- Tampa, Fla., Tampa Hardware Co.

Headquarters for Canada:

Columbia Graphophone Co., 54-56 Wellington St., West, Toronto, Ont.

Executive Office

COLUMBIA GRAPHOPHONE CO. Woolworth Building New York

CARRYING ON BIG CAMPAIGN

H. R. Eisenbrandt Sons, Inc., Victor wholesalers and retailers, Baltimore, Md., are carrying on a strong campaign particularly through the medium of window displays, featuring the use of Victrolas and Victor records for educational purposes.

ATTRACT AUDIENCE OF 3,000

An Edison tone test in Infantry Hall, Providence, R. I., recently attracted an audience of over 2,000 people. The tone test was under the auspices of the J. A. Foster Co., local Edison dealers.

Jos. M. Mann, head of the Mann Piano Co., Baltimore, is emphasizing in his Victor and Sonora advertising the great part played by music in the winning of the war, and is getting results thereby.

Some Leading Jobbers of Talking Machines in America

1856 **WURLITZER** 1916

VICTOR
DISTRIBUTORS
VICTORS EXCLUSIVELY

We make a specialty of getting the order out on time—every time.

The Rudolph Wurlitzer Co.
CINCINNATI AND CHICAGO
Two points of supply; order from the nearer

TEST IT. 

OUR VICTOR
Record Service

has a reputation for efficiency.
Suppose you try it.

E. F. DROOP & SONS CO.
1300 G. STREET, WASHINGTON, D. C.
231 N. HOWARD STREET, BALTIMORE, MD



YAHR & LANGE DRUG CO.
MILWAUKEE, WIS.

Wholesale Distributors for

THE INSTRUMENT OF QUALITY
Sonora
CLEAR AS A BELL 

in Wisconsin
and Upper Michigan

W. J. DYER & BRO.
NORTHWESTERN DISTRIBUTORS

OF THE

 **VICTOR**
Machines, Records and Supplies

Shipped Promptly to all
Points in the Northwest

**STARR Phonographs
and GENNETT Records**

Complete Stock and REAL Service

Crafts-Starr
PHONOGRAPH CO.

Factory Distributors
218-220 NORTH SECOND STREET, RICHMOND, VIRGINIA
Write for Dealers' Proposition

Smith, Kline & French Co.
PHILADELPHIA

Wholesale Distributors for

THE INSTRUMENT OF QUALITY
Sonora
CLEAR AS A BELL 

In PENNSYLVANIA, NEW JERSEY
and DELAWARE

Hillman & Son Phonograph Co.
Wheeling, West Virginia

Exclusive Wholesale Distributors for West
Virginia and Virginia

THE INSTRUMENT OF QUALITY
Sonora
CLEAR AS A BELL 

All models shipped promptly from our large
warehouse, 1126 Main Street

Diamond Needles and Sapphire Needles for Sale

Strevell-Paterson Hdw. Co.
Wholesale Distributors

for
Utah, Idaho, Colorado, Wyoming
and New Mexico

THE INSTRUMENT OF QUALITY
Sonora
CLEAR AS A BELL 

Complete Stock on Hand at All Times
SALT LAKE CITY UTAH

C. L. Marshall & Co.
Wholesale Distributors
for Michigan

THE INSTRUMENT OF QUALITY
Sonora
CLEAR AS A BELL 

The Ohio Sales Company, Inc.
Wholesale Distributors
for Ohio

810-111 EMPIRE BLDG., DETROIT, MICH.

Mickel Bros. Co.

Omaha, Nebraska
Des Moines, Iowa

Victor Distributors

Southern Victor Dealers
Largest Stock VICTROLAS and RECORDS.
Prompt Shipment and Low Freight Rates.

WALTER D. MOSES & CO.
Oldest Music House in Virginia or North Carolina.
RICHMOND, VA.

**OLIVER
DITSON
COMPANY**

Largest VICTOR Talking
Machine Distributors East of
Chicago.

Creators of "The Fastest Victor
Service." Let us tell you more
about our service.

BOSTON

Sherman, Clay & Co.

San Francisco, Los Angeles, Portland, Seattle, Spokane
PACIFIC COAST DISTRIBUTORS OF
VICTOR PRODUCTS

The PERRY B. WHITSIT CO.
Distributors of
Victrolas and Victor Records
COLUMBUS, OHIO

ROUNTREE-CHERRY
RICHMOND VIRGINIA

Wholesale Distributors for

THE INSTRUMENT OF QUALITY
Sonora
CLEAR AS A BELL 

YOU
above all must be satisfied!

IN NORTH AND SOUTH CAROLINA

The Electric Supply & Equipment Co.
Exclusive Wholesale Distributors for
Southern New England

THE INSTRUMENT OF QUALITY
Sonora
CLEAR AS A BELL 

Complete stocks carried in Boston and Hartford

Little Bldg. 103 Allyn St.
BOSTON, MASS. HARTFORD, CONN.

*Have You Noted the Growth of
This Department?*

*Special Rates for Jobbers' Directory
on Application*

During the past six months this Jobbers'
Directory has grown steadily in importance.
It affords progressive jobbers an opportunity
to keep their names before the dealers con-
sistently and regularly, and provides repre-
sentation in the Jobbers' Directory of the
publication which is the recognized authority
of the industry.
Join the progressive jobbers on this page
next month.

Victor Exclusively
EASTERN TALKING MACHINE CO.
177 Tremont Street, Boston
VICTOR DISTRIBUTORS

THE NEW EDISON



A Master Product of A Master Mind

JOBBERS OF THE NEW EDISON, EDISON RE-CREATIONS, THE NEW EDISON DIAMOND AMBEROLA AND BLUE AMBEROL RECORDS

CALIFORNIA
Los Angeles—Edison Phonographs, Ltd.
San Francisco—Edison Phonographs, Ltd.

COLORADO
Denver—Denver Dry Goods Co.

CONNECTICUT
New Haven—Pardee-Ellenberger Co., Inc.

GEORGIA
Atlanta—Phonographs, Inc.

ILLINOIS
Chicago—The Phonograph Co.
James I. Lyons. (Amberola only.)

INDIANA
Indianapolis—Kipp Phonograph Co.

IOWA
Des Moines—Harger & Blish.
Sioux City—Harger & Blish.

LOUISIANA
New Orleans—Diamond Music Co., Inc.

MASSACHUSETTS
Boston—Pardee-Ellenberger Co.

MICHIGAN
Detroit—Phonograph Co., of Detroit.

MINNESOTA
Minneapolis—Laurence H. Lucker.

MISSOURI
Kansas City—The Phonograph Co. of Kansas City.
St. Louis—Silverstone Music Co.

MONTANA
Helena—Montana Phonograph Co.

NEBRASKA
Omaha—Shultz Bros.

NEW JERSEY
Paterson—James K. O'Dea (Amberola only.)

NEW YORK
Albany—American Phonograph Co.

New York—The Phonograph Corp. of Manhattan.
Syracuse—Frank E. Bolway & Son, Inc.
W. D. Andrews Co. (Amberola only.)
Buffalo—W. D. & C. N. Andrews Co. (Amberola only.)

OHIO
Cincinnati—The Phonograph Co.
Cleveland—The Phonograph Co.

OREGON
Portland—Edison Phonographs, Ltd.

PENNSYLVANIA
Philadelphia—Girard Phonograph Co.
Pittsburgh—Buchn Phonograph Co.
Williamsport—W. A. Myers.

RHODE ISLAND
Providence—J. A. Foster Co. (Amberola only.)

TEXAS
Dallas—Texas-Oklahoma Phonograph Co.

UTAH
Ogden—Proudfit Sporting Goods Co.

VIRGINIA
Richmond—The C. B. Haynes Co., Inc.

WISCONSIN
Milwaukee—The Phonograph Co. of Milwaukee.

CANADA
Montreal—R. S. Williams & Sons Co., Ltd.
St. John—W. H. Thorne & Co., Ltd.
Toronto—R. S. Williams & Sons Co., Ltd.
Vancouver—Kent Piano Co., Ltd.
Winnipeg—R. S. Williams & Sons Co., Ltd.
Calgary—R. S. Williams & Sons Co., Ltd.



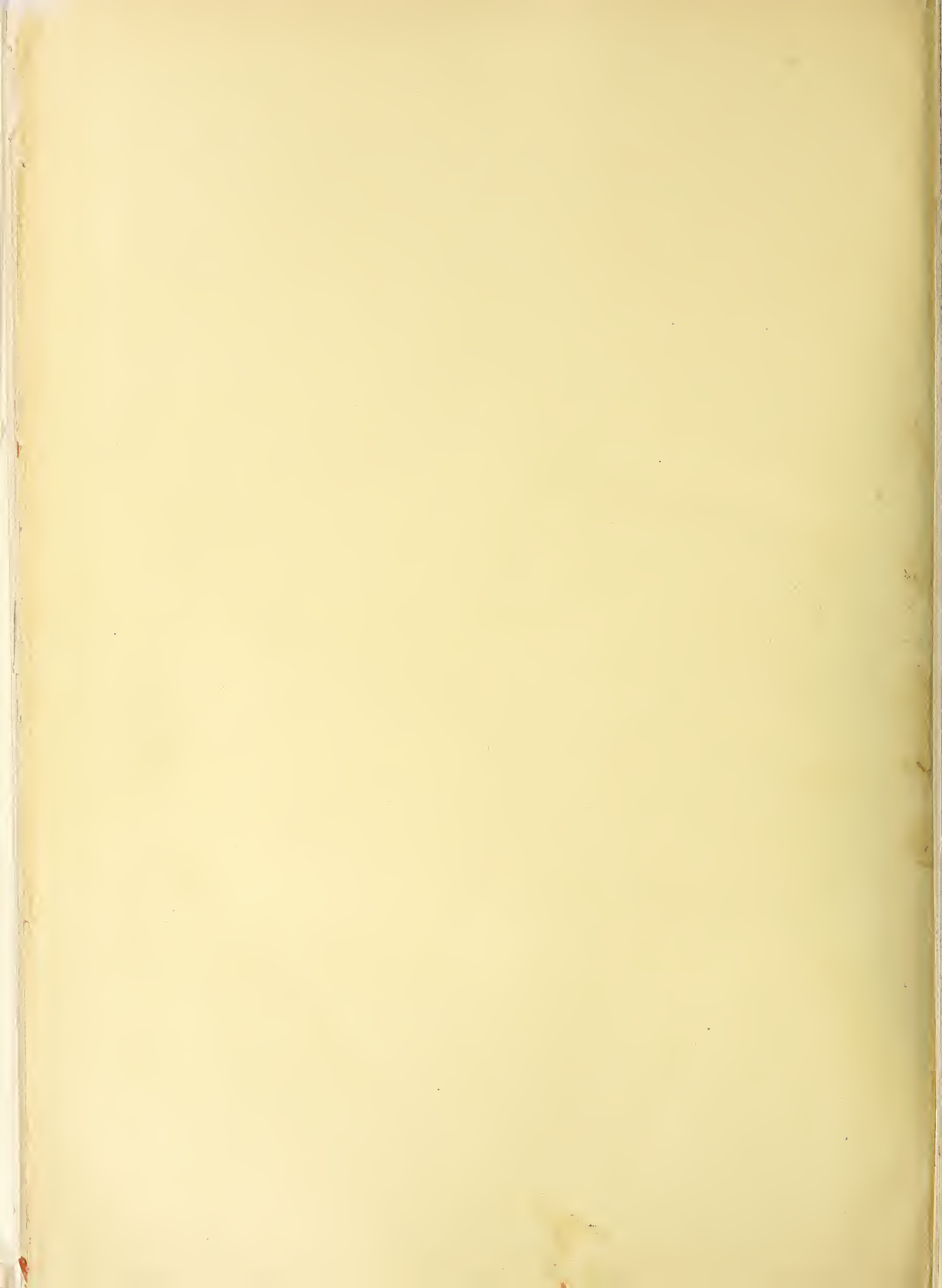

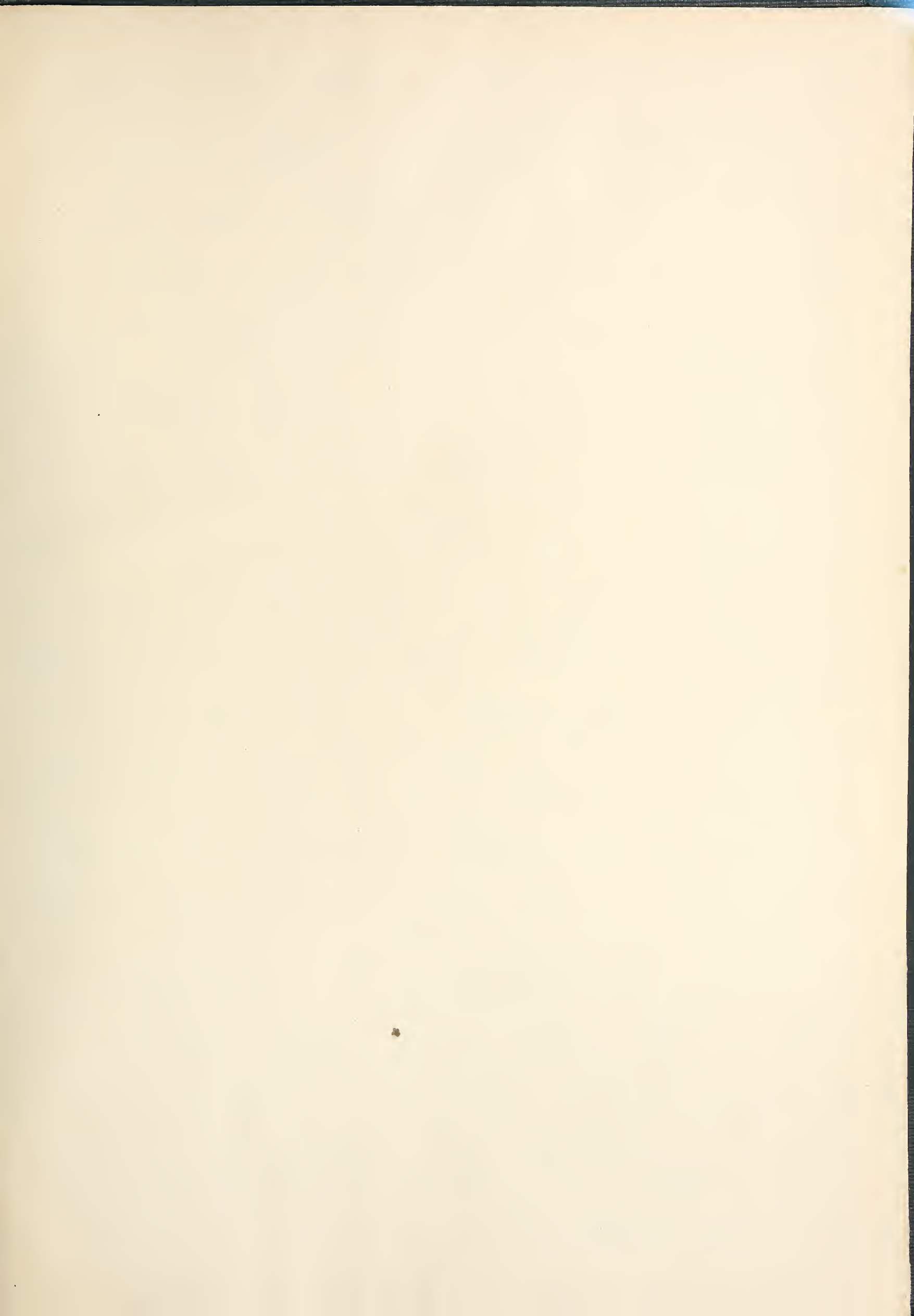

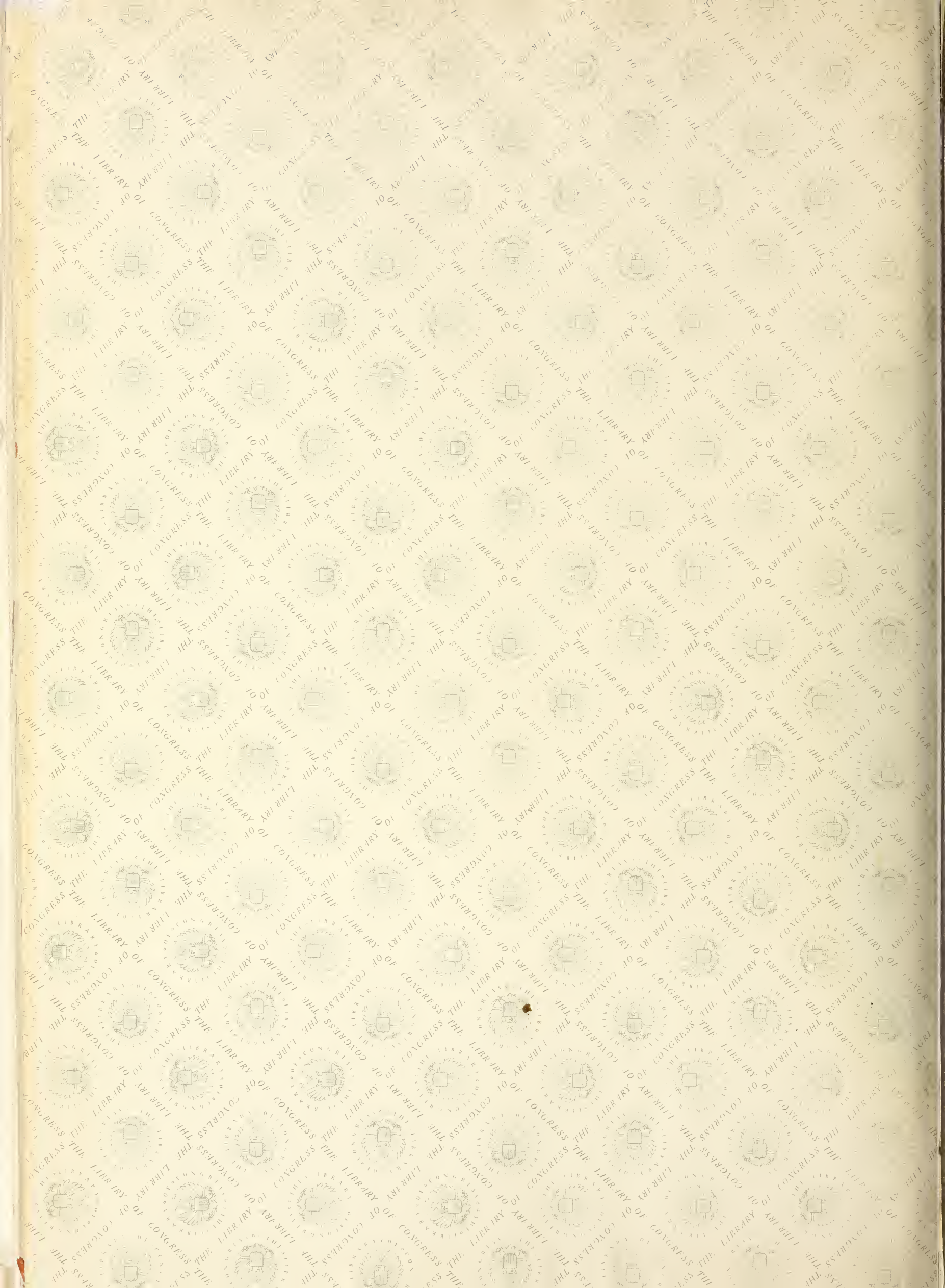

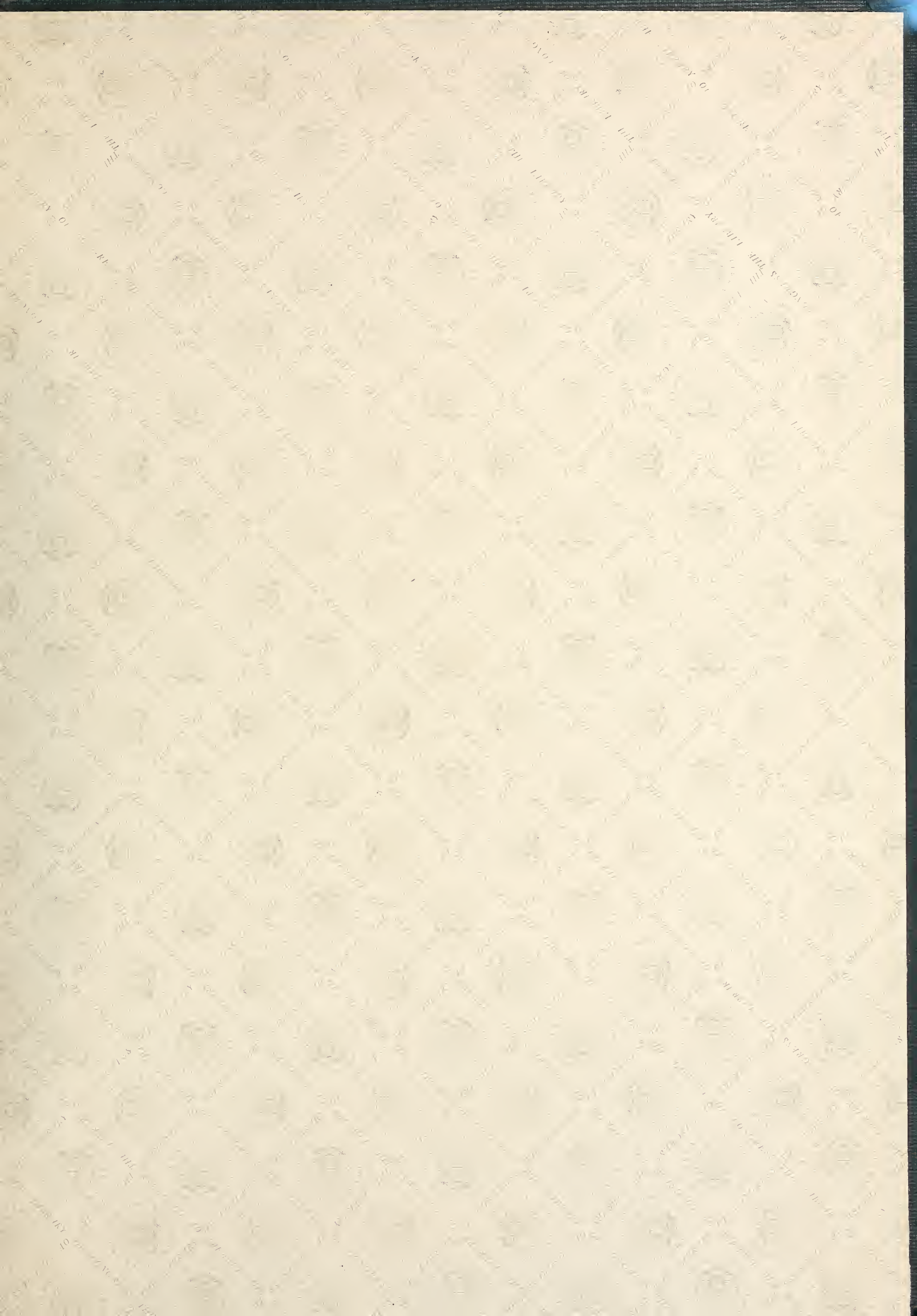

LIBRARY OF CONGRESS

0 021 248 784 3