

UC-NRLF



QB 79 283











# RAILROAD STRUCTURES AND ESTIMATES

BY

J. W. ORROCK

M. CAN. SOC. C. E., MEM. AM. RY. ENG. ASSOC.,  
PRIN. ASST. ENGINEER C. P. R.

*SECOND EDITION, FULLY REVISED*

LIBRARY OF  
CALIFORNIA

NEW YORK

JOHN WILEY & SONS, INC.

LONDON: CHAPMAN & HALL, LIMITED

1918

The publishers and author will be grateful to readers who will kindly call attention to any errors in this volume.

TF 270  
08  
1918

COPYRIGHT, 1909, 1918,

BY

J. W. ORROCK

Stanbope Press  
F. H. GILSON COMPANY  
BOSTON, U.S.A.



382061

#### NOTE

THE prices given in this book are those which ruled in normal times, that is previous to 1915-16.

There are no prices at the present time that would be of any value for comparative purposes.

## PREFACE TO THE SECOND EDITION.

THE chapters of this book have been rearranged to conform, as near as may be, with the classification of accounts as prescribed by the Interstate Commerce Commission, issue of 1914; there has also been added a large amount of new material and wherever possible the unit cost or an estimate is given for all items of track work, track structures and buildings. A feature has also been made of quantities for track material, that to a very large extent is not dealt with in other textbooks.

It has often been said that cost figures are not of much value unless accompanied by exhaustive detail. This probably is correct from a contractor's standpoint, but it is also true that even with detailed figures any two jobs, built exactly alike and under the same conditions, will vary more in the details item for item than in the totals; and it is with the latter figures especially that the engineer is mostly concerned, as in the multiplicity of work usually dealt with there is seldom time to analyze details until the work is authorized. For this reason the quantities and cost data have been arranged for handy reference, whereby a quick total estimate can be made that may serve as a guide when more authentic information is lacking; and in this connection it should be remembered that in the final analysis the figures depend not from what can be had from a book but rather on the judgment and experience of the estimator and his knowledge of the labor and material market in the vicinity in which the proposed work is to be executed.

Acknowledgment is here made to the various technical magazines, *Engineering News*, *Railway Age Gazette*, *Maintenance of Way Engineer*, *Railway World*, *Engineering and Contracting*, and many others for material incorporated either in whole or in part under the various subjects dealt with; also to many members of the engineering staff of the various railways for valuable information received and courtesies extended.

J. W. ORROCK.

New York, *November*, 1917.

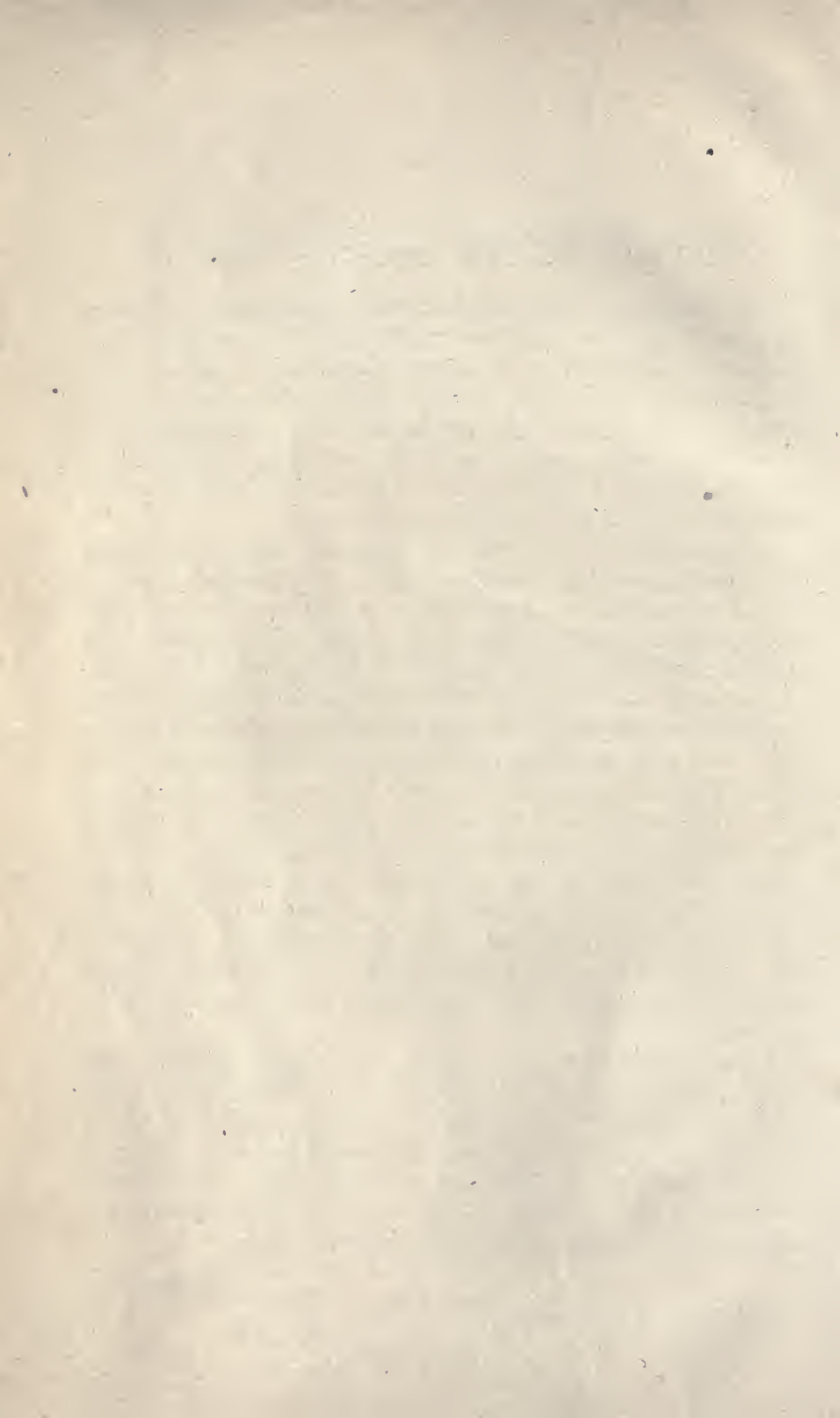

# TABLE OF CONTENTS.

## PART ONE.

### TRACK AND TRACK STRUCTURES.

#### CHAPTER I.

##### TRACK MATERIAL AND ESTIMATES.

	PAGES
Rail properties; Rail feet into tons; Rail tons into track miles; Rail joints and bolts; Elements of various joints; Track work and material; Cost above subgrade; Turnouts—quantities and cost; Cross-overs—quantities and cost; Track material for quick estimating; Rail and fastenings per mile; Rail renewals; Switch ties for turn-outs; Switch ties for crossovers . . . . .	4-23

#### CHAPTER II.

##### STRUCTURAL MATERIAL AND ESTIMATES.

Weights of bridge spans; Weights of steel trestles; Wooden trestles; Subways; Highway bridges; Gravity retaining walls; Concrete culverts; Buildings and miscellaneous . . . . .	24-39
--	-------

#### CHAPTER III.

##### COST OF RAILROADS.

Unit prices; Clearing and grubbing; Cost of train service; Equipment and rentals . . . . .	40-51
--	-------

#### CHAPTER IV.

##### GRADE SEPARATION.

Benefits and objections; Fill or excavation; Costs; Street grades; Clearances; Equipment cost and rental rates . . . . .	52-61
--	-------

#### CHAPTER V.

##### TUNNELS AND SUBWAYS.

Tunnel sections; Driving; Design; Cost; Drainage; Floors; Subways;—Types; Weight of steel; Reinforced concrete; Estimates	62-82
---	-------

## CHAPTER VI.

**BRIDGES, TRESTLES, AND CULVERTS.**

Abutments; Piers; Quantities; Retaining walls; Cribwork; Railway bridges; Highway bridges; Wooden bridges; Trestles; Culverts.....	83-162
--	--------

## CHAPTER VII.

**ELEVATED STRUCTURES.**

Open viaducts; Steel structures; Steel and concrete; Reinforced concrete; Masonry walls and fill; Reinforced walls and fill.....	163-170
--	---------

## CHAPTER VIII.

**TIES.**

Wood ties; Kind, life and cost; Cost of various grades; Treated ties; Cost of treatment; Tie formula; Steel ties.....	171-183
---	---------

## CHAPTER IX.

**RAIL.**

Rail steel; Rail design; Estimating prices; Scrap values; Re-rolling rails.....	184-189
---	---------

## CHAPTER X.

**OTHER TRACK MATERIAL.**

Rail joints; Bolts; Anchors; Spikes; Tie plates; Turnouts; Switches; Frogs; Cross overs; Slip switches; Derails; Bumping posts; Stop blocks; Diamonds; Interlocking.....	190-238
--	---------

## CHAPTER XI.

**BALLAST.**

Kinds of ballast; Ballast sections; Templates; Cost.....	239-249
--	---------

## CHAPTER XII.

**TRACK LAYING AND SURFACING.**

Rail laying; Rail renewals; Tamping; Tie plugs; Drainage; Equating track values; Tool equipment; Hand and motor cars; Section work.....	250-262
---	---------

## CHAPTER XIII.

**RIGHT OF WAY FENCES.**

Fences; Gates; Cattle guards; Wing fences.....	263-274
--	---------

CHAPTER XIV.

SNOW AND SAND FENCES AND SNOW SHEDS.

Permanent snow fences; Portable snow fences; Picket fence; Snow sheds..... 275-285

CHAPTER XV.

CROSSINGS AND SIGNS.

Farm crossings; Public road crossings; Watchman's cabin; Gates and towers; Track signs..... 286-307

PART TWO.

ROADWAY BUILDINGS.

CHAPTER XVI.

STATION AND OTHER BUILDINGS.

Stations; Shelters; Trainsheds; Platform canopies..... 311-338

CHAPTER XVII.

ROADWAY BUILDINGS.

Tool houses; Section houses; Rest houses; Bunk houses; Watch house; Freight houses; Platforms; Scales; Ice houses; Stock yards; Mail cranes..... 339-425

CHAPTER XVIII.

WATER STATIONS.

Piping; Tanks; Pumps; Standpipes; Pump houses; Dams..... 426-471

CHAPTER XIX.

FUEL STATIONS.

Coaling plants; Sand storage..... 472-494

CHAPTER XX.

SHOPS AND ENGINE HOUSES.

Engine houses; Ash pits; Turntables; Boiler house; Machine shops; Store houses; Oil and store houses; Locomotive and Car shops.. 495-574





1

RAILROAD STRUCTURES AND ESTIMATES



THE  
SOUTHERN  
RAILWAY

PART ONE.  
TRACK AND TRACK STRUCTURES.

## CHAPTER I.

## TRACK MATERIAL AND ESTIMATES.

A. S. C. E. RAIL.

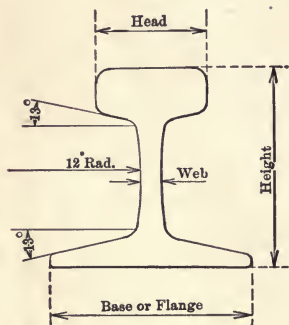

A. R. E. A. RAIL.

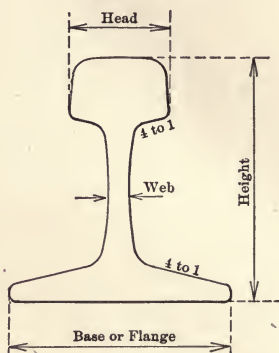

A. S. C. E. RAIL.

Weight per yard.	Area of section.	Dimensions.				Properties.			
		Height.	Base.	Head.	Web.	I.	r.	S.	X.
Pounds.	In. <sup>2</sup>	In.	In.	In.	In.	In. <sup>4</sup>	In.	In. <sup>3</sup>	In.
110	10.80	6 $\frac{1}{8}$	6 $\frac{1}{8}$	2 $\frac{7}{8}$	3 $\frac{7}{8}$	55.2	2.26	17.2	2.92
100	9.84	5 $\frac{3}{4}$	5 $\frac{3}{4}$	2 $\frac{3}{4}$	1 $\frac{9}{8}$	44.0	2.11	14.6	2.73
95	9.28	5 $\frac{1}{8}$	5 $\frac{9}{8}$	2 $\frac{1}{8}$	1 $\frac{1}{8}$	38.8	2.05	13.3	2.65
90	8.83	5 $\frac{3}{8}$	5 $\frac{3}{8}$	2 $\frac{3}{8}$	1 $\frac{9}{8}$	34.4	1.97	12.2	2.55
85	8.33	5 $\frac{1}{8}$	5 $\frac{1}{8}$	2 $\frac{1}{8}$	1 $\frac{9}{8}$	30.1	1.90	11.1	2.47
80	7.86	5	5	2 $\frac{1}{2}$	1 $\frac{5}{8}$	26.4	1.83	10.1	2.38
75	7.33	4 $\frac{1}{2}$	4 $\frac{3}{8}$	2 $\frac{3}{8}$	1 $\frac{5}{8}$	22.9	1.77	9.1	2.30
70	6.81	4 $\frac{5}{8}$	4 $\frac{3}{8}$	2 $\frac{7}{8}$	1 $\frac{3}{4}$	19.7	1.70	8.2	2.22
65	6.33	4 $\frac{7}{8}$	4 $\frac{7}{8}$	2 $\frac{3}{8}$	1 $\frac{3}{8}$	16.9	1.63	7.4	2.14
60	5.93	4 $\frac{1}{4}$	4 $\frac{1}{4}$	2 $\frac{3}{8}$	1 $\frac{1}{4}$	14.6	1.57	6.6	2.05
55	5.38	4 $\frac{1}{8}$	4 $\frac{1}{8}$	2 $\frac{1}{4}$	1 $\frac{1}{8}$	12.0	1.50	5.7	1.97
50	4.87	3 $\frac{7}{8}$	3 $\frac{7}{8}$	2 $\frac{1}{8}$	1 $\frac{1}{8}$	9.9	1.43	5.0	1.88
45	4.40	3 $\frac{1}{4}$	3 $\frac{1}{4}$	2	1 $\frac{1}{4}$	8.1	1.36	4.3	1.78

A. R. E. A. RAIL.

(Tentative sections proposed.)

Weight per yard.	Area of sections.	Dimensions.				Properties.			
		Height.	Base.	Head.	Web.	I.	r.	S.	X.
Pounds.	In. <sup>2</sup>	In.	In.	In.	In.	In. <sup>4</sup>	In.	In. <sup>3</sup>	In.
90	8.82	5 $\frac{5}{8}$	5 $\frac{1}{8}$	2 $\frac{9}{8}$	1 $\frac{9}{8}$	38.7	2.09	12.56	2 $\frac{3}{4}$
100	9.95	6	5 $\frac{3}{8}$	2 $\frac{1}{6}$	1 $\frac{9}{8}$	49.0	2.22	15.10	2 $\frac{3}{4}$
110	10.82	6 $\frac{1}{4}$	5 $\frac{3}{8}$	2 $\frac{1}{6}$	1 $\frac{9}{8}$	57.0	2.29	16.7	2 $\frac{5}{8}$
120	11.85	6 $\frac{1}{2}$	5 $\frac{1}{4}$	2 $\frac{1}{2}$	1 $\frac{9}{8}$	67.6	2.45	18.9	2 $\frac{5}{8}$
130	12.71	6 $\frac{3}{4}$	6	2 $\frac{1}{2}$	1 $\frac{5}{8}$	77.4	2.46	20.8	3 $\frac{1}{2}$
140	13.58	7	6 $\frac{1}{4}$	3	1 $\frac{1}{8}$	89.2	2.56	23.1	3 $\frac{9}{4}$

A. R. A. RAIL.

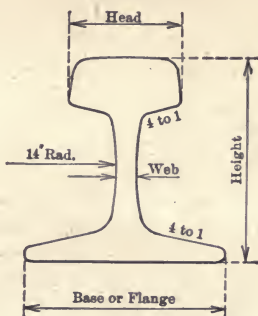

Series A.

Weight per yard.	Area of section.	Dimensions.				Properties.			
		Height.	Base.	Head.	Web.	I.	r.	S.	X.
Pounds.	In. <sup>2</sup>	In.	In.	In.	In.	In. <sup>4</sup>	In.	In. <sup>3</sup>	In.
100	9.84	6	5½	2¾	9/16	48.9	2.23	15.1	2.75
90	8.82	5 5/8	5 1/8	2 9/16	9/16	38.7	2.09	12.5	2.54
80	7.86	5 1/8	4 5/8	2 1/2	3/4	28.8	1.91	10.2	2.31
70	6.82	4 3/4	4 1/4	2 3/8	3/4	21.1	1.76	8.3	2.30
60	5.86	4 1/2	4	2 1/4	1 1/2	15.4	1.62	6.5	2.13

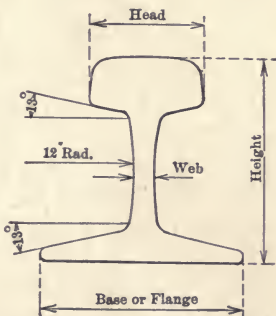

Series B.

Weight per yard.	Area of section.	Dimensions.				Properties.			
		Height.	Base.	Head.	Web.	I.	r.	S.	X.
Pounds.	In. <sup>2</sup>	In.	In.	In.	In.	In. <sup>4</sup>	In.	In. <sup>3</sup>	In.
100	9.85	5 1/4	5 9/16	2 21/32	9/16	41.3	2.05	13.7	2.63
90	8.87	5 1/8	4 9/16	2 9/16	9/16	32.3	1.91	11.5	2.45
80	7.91	4 1/2	4 7/16	2 7/16	3/4	25.1	1.78	9.4	2.27
70	6.89	4 3/8	4 3/8	2 3/8	3/4	18.6	1.64	7.8	2.16
60	5.87	4 1/8	3 1/8	2 1/8	3/4	13.3	1.51	6.0	1.95

TABLE 1.—FEET OF RAIL INTO TONS.

WEIGHTS OF RAIL OF VARIOUS SECTIONS IN GROSS TONS PER ANY LENGTH IN FEET (SINGLE RAIL). (J. G. Wishart.)

Length of rail, ft.	Weight in tons.											
	120-lb.	110-lb.	105-lb.	100-lb.	95-lb.	90-lb.	85-lb.	80-lb.	75-lb.	70-lb.	65-lb.	60-lb.
1	0.017	0.016	0.015	0.014	0.014	0.013	0.012	0.011	0.011	0.010	0.009	0.008
2	0.035	0.032	0.031	0.029	0.028	0.026	0.025	0.023	0.022	0.020	0.019	0.017
3	0.053	0.049	0.046	0.044	0.042	0.040	0.037	0.035	0.033	0.031	0.029	0.026
4	0.071	0.065	0.062	0.059	0.056	0.053	0.050	0.047	0.044	0.041	0.038	0.035
5	0.089	0.081	0.078	0.074	0.070	0.067	0.063	0.059	0.055	0.052	0.048	0.044
6	0.107	0.098	0.093	0.089	0.084	0.080	0.075	0.071	0.067	0.062	0.058	0.053
7	0.125	0.114	0.109	0.104	0.099	0.093	0.088	0.083	0.078	0.072	0.067	0.062
8	0.142	0.131	0.125	0.119	0.113	0.107	0.101	0.095	0.089	0.083	0.077	0.071
9	0.160	0.147	0.140	0.133	0.127	0.120	0.113	0.107	0.100	0.093	0.087	0.080
10	0.178	0.163	0.156	0.148	0.141	0.133	0.126	0.119	0.111	0.104	0.096	0.089
20	0.357	0.327	0.312	0.297	0.282	0.267	0.253	0.238	0.223	0.208	0.193	0.178
30	0.535	0.491	0.468	0.446	0.424	0.401	0.379	0.357	0.334	0.312	0.290	0.267
40	0.714	0.654	0.625	0.595	0.565	0.535	0.506	0.476	0.446	0.416	0.386	0.357
50	0.892	0.818	0.781	0.744	0.706	0.669	0.632	0.595	0.558	0.520	0.483	0.446
60	1.071	0.982	0.937	0.892	0.848	0.803	0.758	0.714	0.669	0.625	0.580	0.535
70	1.250	1.145	1.093	1.041	0.989	0.937	0.885	0.833	0.781	0.729	0.677	0.625
80	1.428	1.309	1.250	1.190	1.131	1.071	1.011	0.952	0.892	0.833	0.773	0.714
90	1.607	1.473	1.406	1.339	1.272	1.205	1.138	1.071	1.004	0.937	0.870	0.803
100	1.785	1.636	1.562	1.488	1.413	1.339	1.264	1.190	1.116	1.041	0.967	0.892
200	3.571	2.273	3.125	2.976	2.827	2.678	2.529	2.381	2.232	2.083	1.934	1.785
300	5.357	4.910	4.687	4.464	4.241	4.017	3.794	3.571	3.348	3.125	2.901	2.678
400	7.142	6.547	6.250	5.952	5.654	5.357	5.059	4.761	4.464	4.166	3.869	3.571
500	8.928	8.184	7.812	7.440	7.068	6.696	6.324	5.952	5.580	5.208	4.836	4.464
600	10.714	9.821	9.375	8.928	8.482	8.035	7.589	7.142	6.696	6.250	5.803	5.357
700	12.500	11.458	10.937	10.416	9.895	9.375	8.854	8.333	7.812	7.291	6.770	6.250
800	14.285	13.095	12.500	11.904	11.309	10.714	10.119	9.523	8.928	8.333	7.738	7.142
900	16.071	14.731	14.062	13.392	12.723	12.053	11.383	10.714	10.044	9.375	8.705	8.035
1,000	17.857	16.368	15.625	14.881	14.136	13.392	12.648	11.904	11.160	10.416	9.672	8.928
2,000	35.714	32.737	31.250	29.761	28.273	26.785	25.297	23.809	22.321	20.833	19.345	17.857
3,000	53.571	49.106	46.875	44.642	42.410	40.178	37.946	35.714	33.482	31.250	29.017	26.785
4,000	71.428	65.475	62.500	59.523	56.547	53.571	50.595	47.619	44.642	41.666	38.690	35.714
5,000	89.285	81.843	78.125	74.404	70.684	66.964	63.244	59.523	55.803	52.083	48.363	44.642
6,000	107.142	98.212	93.750	89.285	84.821	80.357	75.892	71.428	66.964	62.500	58.035	53.571
7,000	125.000	114.581	109.375	104.166	98.958	93.750	88.541	83.333	78.125	72.916	67.708	62.500
8,000	142.857	130.950	125.000	119.047	113.095	107.142	101.190	95.238	89.285	83.333	77.381	71.428
9,000	160.714	147.318	140.625	133.928	127.232	120.535	113.839	107.142	100.446	93.750	87.053	80.357
10,000	178.571	163.687	156.250	148.809	141.369	133.928	126.488	119.047	111.607	104.166	96.726	89.285

From Table 1 the total tonnage of any given length of rail can be quickly and accurately ascertained by the addition of two or more quantities. The following example will illustrate the method of using the table. Given 4237 lin. ft. of 80-lb. rail, to find the total tonnage. From the column headed 80 lb. take from opposite 4000 in the first column the amount 47.619; from opposite 200, the amount 2.381; from opposite 30, the amount 0.357; and from opposite 7, the amount 0.083. The sum of these four quantities equals 50.440 tons, the weight of the given amount of rail.

TABLE 2. — TONS OF RAIL INTO TRACK MILES.

LENGTHS OF RAIL OF VARIOUS SECTIONS IN TRACK MILES PER ANY WEIGHT IN GROSS TONS.  
(J. G. Wishart.)

Tons of rail.	Length in miles.											
	120-lb.	110-lb.	105-lb.	100-lb.	95-lb.	90-lb.	85-lb.	80-lb.	75-lb.	70-lb.	65-lb.	60-lb.
1	0.005	0.005	0.006	0.006	0.006	0.007	0.007	0.008	0.008	0.009	0.009	0.010
2	0.010	0.011	0.012	0.012	0.013	0.014	0.015	0.015	0.017	0.018	0.019	0.021
3	0.015	0.017	0.018	0.019	0.020	0.021	0.022	0.023	0.025	0.027	0.029	0.031
4	0.021	0.023	0.024	0.025	0.026	0.028	0.029	0.031	0.033	0.036	0.039	0.042
5	0.026	0.028	0.030	0.031	0.033	0.035	0.037	0.039	0.042	0.045	0.049	0.053
6	0.031	0.034	0.036	0.038	0.040	0.042	0.044	0.047	0.050	0.054	0.058	0.063
7	0.037	0.040	0.042	0.044	0.046	0.049	0.052	0.055	0.059	0.063	0.068	0.074
8	0.042	0.046	0.048	0.050	0.053	0.056	0.059	0.063	0.067	0.072	0.078	0.084
9	0.047	0.052	0.054	0.057	0.060	0.063	0.067	0.071	0.076	0.081	0.088	0.095
10	0.053	0.057	0.060	0.063	0.067	0.070	0.074	0.079	0.084	0.090	0.097	0.106
20	0.106	0.115	0.121	0.127	0.134	0.141	0.149	0.159	0.169	0.181	0.195	0.212
30	0.159	0.173	0.181	0.190	0.201	0.212	0.224	0.238	0.254	0.272	0.293	0.318
40	0.212	0.231	0.242	0.254	0.267	0.282	0.299	0.318	0.339	0.363	0.391	0.424
50	0.265	0.289	0.303	0.318	0.334	0.353	0.374	0.397	0.424	0.454	0.489	0.530
60	0.318	0.347	0.363	0.381	0.401	0.424	0.449	0.477	0.509	0.545	0.587	0.636
70	0.371	0.405	0.424	0.445	0.468	0.494	0.524	0.556	0.593	0.636	0.685	0.742
80	0.424	0.462	0.484	0.509	0.535	0.565	0.598	0.636	0.678	0.727	0.783	0.848
90	0.477	0.520	0.545	0.572	0.602	0.636	0.673	0.715	0.763	0.818	0.881	0.954
100	0.530	0.578	0.606	0.636	0.669	0.707	0.748	0.795	0.848	0.909	0.979	1.060
200	1.060	1.157	1.212	1.272	1.339	1.414	1.497	1.590	1.697	1.818	1.958	2.121
300	1.590	1.735	1.818	1.909	2.009	2.121	2.246	2.386	2.545	2.727	2.937	3.181
400	2.121	2.314	2.424	2.545	2.679	2.828	2.994	3.181	3.393	3.636	3.916	4.242
500	2.651	2.892	3.030	3.181	3.349	3.535	3.743	3.977	4.242	4.545	4.895	5.303
600	3.181	3.471	3.636	3.818	4.019	4.242	4.492	4.772	5.090	5.454	5.874	6.363
700	3.712	4.049	4.242	4.454	4.689	4.949	5.240	5.568	5.939	6.363	6.853	7.424
800	4.242	4.628	4.848	5.090	5.358	5.656	5.989	6.363	6.787	7.272	7.832	8.484
900	4.772	5.206	5.454	5.727	6.028	6.363	6.738	7.159	7.636	8.181	8.811	9.545
1,000	5.303	5.785	6.060	6.363	6.698	7.070	7.486	7.954	8.484	9.090	9.790	10.606
2,000	10.606	11.570	12.121	12.727	13.397	14.141	14.973	15.909	16.969	18.181	19.580	21.212
3,000	15.909	17.355	18.181	19.090	20.095	21.212	22.459	23.863	25.454	27.272	29.370	31.818
4,000	21.212	23.140	24.242	25.454	26.794	28.282	29.946	31.818	33.939	36.363	39.160	42.424
5,000	26.515	28.925	30.303	31.818	33.492	35.353	37.433	39.772	42.424	45.454	48.951	53.030
6,000	31.818	34.710	36.363	38.181	40.191	42.424	44.919	47.727	50.909	54.545	58.741	63.636
7,000	37.121	40.495	42.424	44.545	46.889	49.494	52.406	55.681	59.393	63.636	68.531	74.242
8,000	42.424	46.281	48.484	50.909	53.588	56.565	59.893	63.636	67.878	72.727	78.321	84.848
9,000	47.727	52.066	54.545	57.272	60.287	63.636	67.379	71.590	76.363	81.818	88.111	95.454
10,000	53.030	57.851	60.606	63.636	66.985	70.707	74.866	79.545	84.848	90.909	97.902	106.060

*Example:* Given 2652 tons of 90-lb. rail, to find the miles of single track which it will lay. From the column headed 90 lb. take from opposite 2000 in the first column the amount 14.141; from opposite 600, 4.242; from opposite 50, 0.353, and from opposite 2, 0.014. The sum of these four quantities equals 18.750 miles, the amount of single track that can be laid with the tonnage of rail given.

TABLE 2a. — FEET IN DECIMALS OF A MILE. (N. J. Brady.)

Miles.	0.000 Ft.	0.001 Ft.	0.002 Ft.	0.003 Ft.	0.004 Ft.	0.005 Ft.	0.006 Ft.	0.007 Ft.	0.008 Ft.	0.009 Ft.
0.00	...	5	11	16	21	26	32	37	42	48
0.01	53	58	63	69	74	79	84	90	95	100
0.02	106	111	116	121	127	132	137	143	148	153
0.03	158	164	169	174	180	185	190	195	201	206
0.04	211	216	222	227	232	238	243	248	253	259
0.05	264	269	275	280	285	290	296	301	306	312
0.06	317	322	327	333	338	343	348	354	359	364
0.07	370	375	380	385	391	396	401	407	412	417
0.08	422	428	433	438	444	449	454	459	465	470
0.09	475	480	486	491	496	502	507	512	517	523
0.10	528	533	539	544	549	554	560	565	570	576
0.11	581	586	591	597	602	607	612	618	623	628
0.12	634	639	644	649	655	660	665	671	676	681
0.13	686	692	697	702	708	713	718	723	729	734
0.14	739	744	750	755	760	766	771	776	781	787
0.15	792	797	803	808	813	818	824	829	834	840
0.16	845	850	855	861	866	871	876	882	887	892
0.17	898	903	908	913	919	924	929	935	940	945
0.18	950	956	961	966	972	977	982	987	993	998
0.19	1003	1008	1014	1019	1024	1030	1035	1040	1045	1051
0.20	1056	1061	1067	1072	1077	1082	1088	1093	1098	1104
0.21	1109	1114	1119	1125	1130	1135	1140	1146	1151	1156
0.22	1162	1167	1172	1177	1183	1188	1193	1199	1204	1209
0.23	1214	1220	1225	1230	1236	1241	1246	1251	1257	1262
0.24	1267	1272	1278	1283	1288	1294	1299	1304	1309	1315
0.25	1320	1325	1331	1336	1341	1346	1352	1357	1362	1368
0.26	1373	1378	1383	1389	1394	1399	1404	1410	1415	1420
0.27	1426	1431	1436	1441	1447	1452	1457	1463	1468	1473
0.28	1478	1484	1489	1494	1500	1505	1510	1515	1521	1526
0.29	1531	1536	1542	1547	1552	1558	1563	1568	1573	1579
0.30	1584	1589	1595	1600	1605	1610	1616	1621	1626	1632
0.31	1637	1642	1647	1653	1658	1663	1668	1674	1679	1684
0.32	1690	1695	1700	1705	1711	1716	1721	1727	1732	1737
0.33	1742	1748	1753	1758	1764	1769	1774	1779	1785	1790
0.34	1795	1800	1806	1811	1816	1822	1827	1832	1837	1843
0.35	1848	1853	1859	1864	1869	1874	1880	1885	1890	1896
0.36	1901	1906	1911	1917	1922	1927	1932	1938	1943	1948
0.37	1954	1959	1964	1969	1975	1980	1985	1991	1996	2001
0.38	2006	2012	2017	2022	2028	2033	2038	2043	2049	2054
0.39	2059	2064	2070	2075	2080	2086	2091	2096	2101	2107
0.40	2112	2117	2123	2128	2133	2138	2144	2149	2154	2160
0.41	2165	2170	2175	2181	2186	2191	2196	2202	2207	2212
0.42	2218	2223	2228	2233	2239	2244	2249	2255	2260	2265
0.43	2270	2276	2281	2286	2292	2297	2302	2307	2313	2318
0.44	2323	2328	2334	2339	2344	2350	2355	2360	2365	2371
0.45	2376	2381	2387	2392	2397	2402	2408	2413	2418	2424
0.46	2429	2434	2439	2445	2450	2455	2460	2466	2471	2476
0.47	2482	2487	2492	2497	2503	2508	2513	2519	2524	2529
0.48	2534	2540	2545	2550	2556	2561	2566	2571	2577	2582
0.49	2587	2592	2598	2603	2608	2614	2619	2624	2629	2635



FET IN DECIMALS OF A MILE.

TABLE 2a (Continued). — FEET IN DECIMALS OF A MILE.

Miles.	0.000 Ft.	0.001 Ft.	0.002 Ft.	0.003 Ft.	0.004 Ft.	0.005 Ft.	0.006 Ft.	0.007 Ft.	0.008 Ft.	0.009 Ft.
0.50	2640	2645	2651	2656	2661	2666	2672	2677	2682	2688
0.51	2693	2698	2703	2709	2714	2719	2724	2730	2735	2740
0.52	2746	2751	2756	2761	2767	2772	2777	2783	2788	2793
0.53	2798	2804	2809	2814	2820	2825	2830	2835	2841	2846
0.54	2851	2856	2862	2867	2872	2878	2883	2888	2893	2899
0.55	2904	2909	2915	2920	2925	2930	2936	2941	2946	2952
0.56	2957	2962	2967	2973	2978	2983	2988	2994	2999	3004
0.57	3010	3015	3020	3025	3031	3036	3041	3047	3052	3057
0.58	3062	3068	3073	3078	3084	3089	3094	3099	3105	3110
0.59	3115	3120	3126	3131	3136	3142	3147	3152	3157	3164
0.60	3168	3173	3179	3184	3189	3194	3200	3205	3210	3216
0.61	3221	3226	3231	3237	3242	3247	3252	3258	3263	3268
0.62	3274	3279	3284	3289	3295	3300	3305	3311	3316	3321
0.63	3326	3332	3337	3342	3348	3353	3358	3363	3369	3374
0.64	3379	3384	3390	3395	3400	3406	3411	3416	3421	3427
0.65	3432	3437	3443	3448	3453	3458	3464	3469	3474	3480
0.66	3485	3490	3495	3501	3506	3511	3516	3522	3527	3532
0.67	3538	3543	3548	3553	3559	3564	3569	3575	3580	3585
0.68	3590	3596	3601	3606	3612	3617	3622	3627	3633	3638
0.69	3643	3648	3654	3659	3664	3670	3675	3680	3685	3691
0.70	3696	3701	3707	3712	3717	3722	3728	3733	3738	3744
0.71	3749	3754	3759	3765	3770	3775	3780	3786	3791	3796
0.72	3802	3807	3812	3817	3823	3828	3833	3839	3844	3849
0.73	3854	3860	3865	3870	3876	3881	3886	3891	3897	3902
0.74	3907	3912	3918	3923	3928	3934	3939	3944	3949	3955
0.75	3960	3965	3971	3976	3981	3986	3992	3997	4002	4008
0.76	4013	4018	4023	4029	4034	4039	4044	4050	4055	4060
0.77	4066	4071	4076	4081	4087	4092	4097	4103	4108	4113
0.78	4118	4124	4129	4134	4140	4145	4150	4155	4161	4166
0.79	4171	4176	4182	4187	4192	4198	4203	4208	4213	4219
0.80	4224	4229	4235	4240	4245	4250	4256	4261	4266	4272
0.81	4277	4282	4287	4293	4298	4303	4308	4314	4319	4324
0.82	4330	4335	4340	4345	4351	4356	4361	4367	4372	4377
0.83	4382	4388	4393	4398	4404	4409	4414	4419	4425	4430
0.84	4435	4440	4446	4451	4456	4462	4467	4472	4477	4483
0.85	4488	4493	4499	4504	4509	4514	4520	4525	4530	4536
0.86	4541	4546	4551	4557	4562	4567	4572	4578	4583	4588
0.87	4594	4599	4604	4609	4615	4620	4625	4631	4636	4641
0.88	4646	4652	4657	4662	4668	4673	4678	4683	4689	4694
0.89	4699	4704	4710	4715	4720	4726	4731	4736	4741	4747
0.90	4752	4757	4763	4768	4773	4778	4784	4789	4794	4800
0.91	4805	4810	4815	4821	4826	4831	4836	4842	4847	4852
0.92	4858	4863	4868	4873	4879	4884	4889	4895	4900	4905
0.93	4910	4916	4921	4926	4932	4937	4942	4947	4953	4958
0.94	4963	4968	4974	4979	4984	4990	4995	5000	5005	5011
0.95	5016	5021	5027	5032	5037	5042	5048	5053	5058	5064
0.96	5069	5074	5079	5085	5090	5095	5100	5106	5111	5116
0.97	5122	5127	5132	5137	5143	5148	5153	5159	5164	5169
0.98	5174	5180	5185	5190	5196	5201	5206	5211	5217	5222
0.99	5227	5232	5238	5243	5248	5254	5259	5264	5269	5275

TABLE 3. — RAIL JOINTS AND BOLTS. A. S. C. E. RAIL.

Rail sec., wt. per yd.	Single bar, wt. per foot, lb.	24 in. long.		26 in. long.		30 in. long.		36 in. long.		Size of bolt.	6 bolts.		4 bolts.	
		Per joint lb.	Per mile tons.	Per joint lb.	Per mile tons.	Per joint lb.	Per mile tons.	Per joint lb.	Per mile tons.		Per joint lb.	Per mile tons.		
110	17.8	71	10.0	77	11.0	89	12.7	107	15.3	1 × 4 $\frac{1}{2}$	11.46	1.64	7.64	1.09
100	15.8	63	9.0	69	9.8	79	11.3	95	13.6	1 × 4 $\frac{1}{2}$	11.16	1.59	7.44	1.06
95	14.7	59	8.4	63	9.0	74	10.6	88	12.9	1 × 4 $\frac{1}{2}$	10.98	1.57	7.32	1.04
90	13.5	54	7.7	59	8.4	68	9.7	81	11.6	1 × 4 $\frac{1}{2}$	7.8	1.11	5.2	0.74
85	12.4	50	7.1	54	7.7	62	8.8	74	10.6	1 × 4 $\frac{1}{2}$	7.8	1.11	5.2	0.74
80	11.5	46	6.7	50	7.3	57	8.1	69	9.9	1 × 4 $\frac{1}{2}$	5.34	0.76	3.56	0.51
75	10.7	43	6.1	46	6.6	54	7.7	64	9.1	1 × 4	5.28	0.76	3.52	0.50
70	10.0	40	5.7	43	6.1	50	7.1	60	8.6	1 × 3 $\frac{3}{4}$	5.10	0.73	3.40	0.49
65	9.2	37	5.3	40	5.7	46	6.6	55	7.9	1 × 3 $\frac{3}{4}$	5.10	0.73	3.40	0.49
60	8.4	33	4.7	37	5.3	42	6.0	50	7.1	1 × 3 $\frac{3}{4}$	4.92	0.70	3.28	0.47
55	7.5	30	4.3	33	4.7	38	5.4	45	6.4	1 × 3 $\frac{3}{4}$	4.92	0.70	3.28	0.47

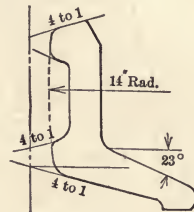
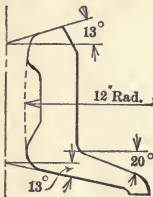

SERIES A RAIL.

Rail sec., wt. per yd.	Wt. per foot, lb.	24 in. long.		26 in. long.		30 in. long.		36 in. long.		Size of bolt.	6 bolts.		4 bolts.	
		Per joint lb.	Per mile tons.	Per joint lb.	Per mile tons.	Per joint lb.	Per mile tons.	Per joint lb.	Per mile tons.		Per joint lb.	Per mile tons.		
100	18.97	76	10.9	82	11.7	95	13.6	114	16.3	1 × 4 $\frac{1}{2}$	11.16	1.59	7.44	1.06
90	16.78	68	9.7	74	10.6	85	12.1	102	14.6	1 × 4 $\frac{1}{2}$	7.8	1.11	5.20	0.74
80	13.52	54	7.7	59	8.4	68	9.7	81	11.6	1 × 4 $\frac{1}{2}$	5.34	0.76	3.56	0.51
70	11.73	47	6.7	50	7.1	59	8.4	71	10.1	1 × 3 $\frac{3}{4}$	5.10	0.73	3.40	0.49
60	10.76	43	6.1	47	6.7	54	7.7	65	9.3	1 × 3 $\frac{3}{4}$	4.92	0.70	3.28	0.47

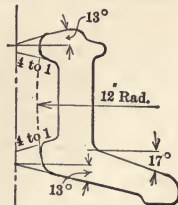
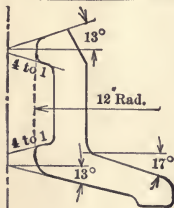

SERIES B RAIL.

Rail sec., wt. per yd.	Wt. per foot, lb.	24 in. long.		26 in. long.		30 in. long.		36 in. long.		Size of bolt.	6 bolts.		4 bolts.	
		Per joint lb.	Per mile tons.	Per joint lb.	Per mile tons.	Per joint lb.	Per mile tons.	Per joint lb.	Per mile tons.		Per joint lb.	Per mile tons.		
100	17.40	60	8.6	65	9.3	87	12.7	111	15.9	1 × 4 $\frac{1}{2}$	11.16	1.59	7.44	1.06
90	14.31	57	8.1	62	8.9	72	10.3	86	12.3	1 × 4 $\frac{1}{2}$	7.8	1.11	5.20	0.74
80	12.72	51	7.4	55	7.9	64	9.1	76	10.9	1 × 4 $\frac{1}{2}$	5.34	0.76	3.56	0.51
70	11.87	47	6.7	51	7.4	59	8.4	71	10.1	1 × 3 $\frac{3}{4}$	5.10	0.73	3.40	0.49
60	9.45	37	5.4	40	5.7	47	6.7	57	8.1	1 × 3 $\frac{3}{4}$	4.92	0.70	3.28	0.47

ELEMENTS OF SOME RAIL JOINTS. A. S. C. E. and other Rail

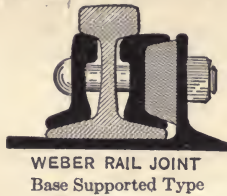

TABLE 4.—ELEMENTS OF VARIOUS ANGLE BAR JOINTS.

Rail sec. wt. per yd.	Kind of joint bar.	Length.	No. of bolts.	Name of rail.	2 bars, wt. per			Area full sec. 2-bars.	Elements of sections.		
					Ft.	Joint.	Mile.		I 2-bars.	S Top 2-bars.	S BTM 2-bars.
Lb.		In.			Lb.	Lb.	Tons.				
100	Angle bar..	30	6	P. S. rail..	32.14	81	11.6	4.91	13.99	6.42	7.19
100	Angle bar..	33	6	A. S. C. E.	31.31	86	12.3	4.60	13.40	5.80	7.04
100	Angle bar..	36	6	Dudley...	22.97	67	9.6	3.37	9.36	4.39	5.14
100	Bonzano...	26½	4	A. S. C. E.	33.36	73	10.4	5.82	32.66	11.55	9.27
100	Bonzano...	30	6	P. S. rail..	26.98	66	9.4	3.96	30.76	12.06	15.28
100	Bonzano...	30	6	P. S. rail..	32.86	82	11.8	5.82	32.66	11.55	9.27
100	Duquesne.	26	4	A. R. A. (B rail)...	45.27	98	14.0	7.23	43.82	14.09	12.96
100	Duquesne.	30	6	P. S. rail..	32.93	83	11.9	4.42	41.05	13.34	11.70
100	100 per cent	30	6	A. S. C. E.	47.60	119	17.0	13.60	47.20	15.00	12.24
100	Weber.....	28	6	A. S. C. E.	45.36	106	15.1	...	23.28	...	...
90	Angle bar..	28	6	A. S. C. E.	30.00	70	10.0	4.28	11.82	5.32	6.12
90	Duquesne.	28	6	A. R. A. (B rail)...	41.72	97	13.9	6.13	34.65	11.61	10.76
90	100 per cent	28	6	A. S. C. E.	38.71	90	12.9	6.42	43.76	15.34	11.66
90	100 per cent	28	6	A. S. C. E.	31.71	75	10.7	4.14	45.28	13.12	11.33
90	100 per cent	26	4	A. S. C. E.	40.18	87	12.4	5.93	38.38	12.97	10.51
85	Angle bar..	30	6	P. S. rail..	28.34	71	10.1	4.29	9.46	4.84	5.45
85	Angle bar..	33	6	A. S. C. E.	24.16	67	9.6	3.55	8.62	5.16	4.95
85	Angle bar..	40	6	A. S. C. E.	23.86	...	...	3.50	8.63	4.08	5.12
85	Bonzano...	29	6	A. S. C. E.	37.15	90	12.9	5.45	26.15	9.30	7.80
85	Continuous	24	4	A. S. C. E.	33.24	67	9.6	4.88	16.74	5.95	11.16
85	Duquesne..	30	6	P. S. rail..	28.96	73	10.4	5.77	30.89	10.86	9.60
85	Wolhaupter	24	4	A. S. C. E.	26.98	54	7.7	3.96	30.76	12.06	15.23
85	100 per cent	28	6	A. S. C. E.	38.20	89	12.7	5.63	34.30	11.55	10.15
80	Angle bar..	26	4	A. S. C. E.	25.28	55	7.9	3.71	7.42	4.33	3.80
80	Angle bar..	30	6	P. & R....	20.80	52	7.4	3.19	5.94	3.26	3.74
80	Angle bar..	36	6	A. S. C. E.	23.04	69	9.9	4.70	9.33	4.36	5.12
80	Bonzano...	24	4	A. S. C. E.	27.74	56	8.0	4.07	11.44	4.81	4.97
80	Continuous	24	4	A. S. C. E.	32.04	64	9.1	4.70	14.43	5.24	10.30

## 12 ESTIMATING PRICES, TRACK WORK AND MATERIAL

TABLE 5.—TRACK WORK AND MATERIAL.

(C. P. R. estimating prices, 1915.)

The following prices cover the cost of work when done under normal conditions and include all freight and storage charges:

**Ties:**

No. 1 track ties, each.....	\$0.65
No. 2 track ties, ".....	0.60
Cull ties, ".....	0.35

(For estimating purposes use 60 ties per 100 feet of track.)

For the various kinds of sawn ties figure:

Hemlock, per 1000 F. B. M.....	\$22.00
Tamarack, " ".....	23.00
Rock elm, " ".....	25.00
Oak " ".....	30.00

No.	Standard Set.	Hemlock.	Tamarack.	Rock elm.	Oak.
7	Turnout.....	\$ 65.00	\$ 68.00	\$ 74.00	\$ 88.00
8	Turnout.....	71.00	74.00	81.00	97.00
9	Turnout.....	75.00	78.00	85.00	101.00
10	Turnout.....	83.00	87.00	95.00	113.00
11	Turnout.....	89.00	93.00	101.00	121.00
12	Turnout.....	90.00	94.00	102.00	122.00
14	Turnout.....	104.00	109.00	118.00	142.00
7	Slip switch.....	101.00	106.00	115.00	138.00
9	Slip switch.....	125.00	130.00	142.00	170.00
7	Crossover 13 ft. centers....	127.00	133.00	144.00	173.00
7	Crossover 16 ft. centers....	135.00	141.00	154.00	184.00
9	Crossover 13 ft. centers....	147.00	154.00	167.00	200.00
9	Crossover 16 ft. centers....	157.00	164.00	178.00	214.00
	Crossing crossover:				
7	13 ft. centers.....	206.00	215.00	234.00	280.00
7	16 ft. centers.....	256.00	267.00	290.00	348.00
9	13 ft. centers.....	245.00	257.00	279.00	334.00
9	13 ft. centers.....	294.00	308.00	334.00	400.00

**Rails:**

As it is now frequently necessary to supply 85 lb. relay rail when a lighter rail has been requisitioned, all estimates should be made for 85 lb. rail unless lighter rail is known to be available for the work:

New rails..... per gross ton.....	\$33.00
Relay rails for Company's tracks ".....	20.00
Relay rails for private sidings ".....	30.00
Scrap rail ".....	15.00
Scrap rail for reinforcement ".....	18.00
Rail fit for relay taken up — credit ".....	20.00

**Fastenings:**

Angle bars, per gross ton.....	\$45.00
Bolts " ".....	79.00
Spikes " ".....	54.00
Tie plates, each.....	0.14
Compromise angle bars, 80-85, per pair.....	1.00
" " 73-85 ".....	1.20
" " 73-80 ".....	1.20
" " 60-65 ".....	1.20
" " 56-72 ".....	1.20

Rail braces, each..... 0.20

On private sidings in preference to using rail braces, use second-hand tie plates, each..... 0.10

TABLE 5 (Continued).—TRACK WORK AND MATERIAL.

**Switches:**

85 lb. material should be estimated for all switches to be installed in tracks laid with heavier than 65 lb. rail, except 100 lb. track, and 65 lb. material in tracks laid with 65 lb. or lighter rail, unless material of another weight is known to be available for the work.

**65 lb. Material:**

High stand, rigid frog No. 9 . . . . .	\$112.00
“ “ “ “ No. 7 . . . . .	106.00
Intermediate or low stand, rigid frog No. 9 . . . . .	100.00
“ “ “ “ No. 7 . . . . .	94.00

**85 lb. Material:**

High stand, spring frog . . . . .	139.00
“ “ rigid frog No. 9 . . . . .	127.00
“ “ “ “ No. 7 . . . . .	125.00
Intermediate or low stand, spring frog . . . . .	128.00
“ “ rigid frog No. 9 . . . . .	116.00
“ “ “ “ No. 7 . . . . .	115.00
Double slip switch No. 9 . . . . .	660.00
“ “ No. 7 . . . . .	650.00
Single slip switch No. 9 . . . . .	510.00
“ “ No. 7 . . . . .	500.00

**Labor:**

When estimating for sidings to be built under standard siding agreement, 10 per cent of the total cost of the siding, including both the applicant's portion and the railway portion, should be added under the heading "Supervision and Contingencies."

Laying split switch, main line . . . . .	\$60.00
“ “ yard “ . . . . .	50.00
Laying diamond . . . . .	40.00
“ slip switch . . . . .	130.00
“ track, per foot . . . . .	0.12
Taking up split switch . . . . .	15.00
“ diamond . . . . .	15.00
“ slip switch . . . . .	50.00
“ track, per foot . . . . .	0.04
Transferring split switch . . . . .	70.00
“ diamond . . . . .	50.00
“ slip switch . . . . .	150.00
“ track, per foot . . . . .	0.18
Ballasting and surfacing, per cubic yard . . . . .	0.50

**Derails:**

Hayes derail, hand operated, in place . . . . .	\$25.00
“ “ with operating stand, in place . . . . .	40.00
“ “ interlocked, in place . . . . .	150.00

**Car Stops:**

Cast iron car stops (as per plan T-14-14a) per pair . . . . .	\$20.00
Earth or cinder car stop (as per plan T-14-14a) . . . . .	30.00
Standard bumping post (as per plan T-14-18a) . . . . .	125.00

**Signals:**

When signal changes are made necessary by the construction of a siding under standard siding agreement, the cost must be borne by the applicant.

The cost for signal changes, due to the introduction of one switch in the main track may be taken as . . . . .	\$300.00
For a trailing point switch in double-track territory . . . . .	200.00

TABLE 6. — SINGLE TRACK: STONE BALLAST.

APPROXIMATE COST OF ONE MILE OR ONE FOOT OF SINGLE MAIN LINE TRACK, ABOVE SUBGRADE.

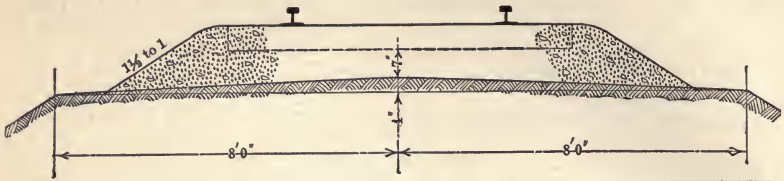

Wt. of rail.	Rails at \$33 ton.		Joint bars at \$45 ton.		Bolts at \$79 ton.		Spikes at \$54 ton.		Ties, 3200 at 65¢ each.	Labor \$635 per mile.	Ballasting and surfacing.	Cost per mile.		Cost per foot.	
	Tons.	Cost.	Tons.	Cost.	Tons.	Cost.	Tons.	Cost.				Cost.	Cost.	Not tie plated.	Tie plated.
120	188.6	\$6224	15.8	\$711	1.35	\$107	4	\$216	\$2080	\$635	\$4000	\$13,973	\$14,873	\$2.65	\$2.82
110	172.9	5706	13.6	612	1.27	100	4	216	2080	635	4000	13,349	14,249	2.53	2.70
100	157.1	5186	11.5	517	1.19	85	4	216	2080	635	4000	12,719	13,519	2.41	2.58
95	149.2	4927	9.40	423	0.96	76	4	216	2080	635	4000	12,356	13,256	2.34	2.51
90	141.4	4667	8.72	392	0.96	76	4	216	2080	635	4000	12,066	12,966	2.28	2.45
85	133.5	4408	7.43	334	0.80	63	4	216	2080	635	4000	11,736	12,636	2.22	2.39
80	125.7	4148	7.14	321	0.80	63	4	216	2080	635	4000	11,464	12,364	2.17	2.34
75	117.8	3889	6.73	303	0.80	63	4	216	2080	635	4000	11,186	12,086	2.12	2.29
70	110.0	3630	6.40	288	0.80	63	4	216	2080	635	4000	10,912	11,812	2.07	2.24
65	102.1	3372	6.07	273	0.71	56	4	216	2080	635	4000	10,632	11,532	2.02	2.19
60	94.3	3116	5.00	225	0.71	56	4	216	2080	635	4000	10,328	11,228	1.96	2.13
56	88.0	2904	2.57	116	0.71	56	4	216	2080	635	4000	10,007	10,907	1.90	2.07

TABLE 6a. — SINGLE TRACK: GRAVEL BALLAST.

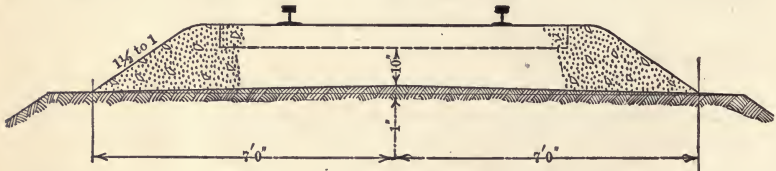

Wt. of rail.	Rails at \$33 ton.		Joint bars at \$45 ton.		Bolts at \$79 ton.		Spikes at \$54 ton.		Ties, 3200 at 65¢ each.	Labor, \$635 per mile.	Ballasting and surfacing.	Cost per mile.		Cost per foot.	
	Tons.	Cost.	Tons.	Cost.	Tons.	Cost.	Tons.	Cost.				Cost.	Cost.	Not tie plated.	Tie plated.
120	188.6	\$6224	15.8	\$711	1.35	\$107	4	\$216	\$2080	\$635	\$1600	\$11,573	\$12,473	\$2.20	\$2.37
110	172.9	5706	13.6	612	1.27	100	4	216	2080	635	1600	10,949	11,849	2.08	2.25
100	157.1	5185	11.5	517	1.19	85	4	216	2080	635	1600	10,318	11,218	1.96	2.13
95	149.2	4926	9.40	423	0.96	76	4	216	2080	635	1600	9,956	10,856	1.89	2.06
90	141.4	4667	8.72	392	0.96	76	4	216	2080	635	1600	9,666	10,566	1.83	2.00
85	133.5	4408	7.43	334	0.80	63	4	216	2080	635	1600	9,336	10,236	1.78	1.95
80	125.7	4148	7.14	321	0.80	63	4	216	2080	635	1600	9,064	9,964	1.72	1.89
75	117.8	3889	6.73	303	0.80	63	4	216	2080	635	1600	8,786	9,686	1.66	1.83
70	110.0	3630	6.40	288	0.80	63	4	216	2080	635	1600	8,512	9,412	1.62	1.79
65	102.1	3371	6.07	273	0.71	56	4	216	2080	635	1600	8,232	9,132	1.56	1.73
60	94.3	3115	5.00	225	0.71	56	4	216	2080	635	1600	7,928	8,828	1.50	1.67
56	88.0	2904	2.57	116	0.71	56	4	216	2080	635	1600	7,607	8,507	1.44	1.61

TABLE 7.—DOUBLE TRACK: STONE BALLAST.

APPROXIMATE COST OF ONE MILE OR ONE FOOT OF DOUBLE MAIN LINE TRACK, ABOVE SUBGRADE.



Wt. of rail.	Rails at \$33 ton.		Joint bars at \$45 ton.		Bolts at \$79 ton.		Spikes at \$54 ton.		Ties, 6400 at 65¢ each.	Labor, \$1000 per mile.	Ballasting and surfacing.	Cost per mile.		Cost per foot.			
	Tons.	Cost.	Tons.	Cost.	Tons.	Cost.	Tons.	Cost.				Cost.	Cost.	Not tie plated.	Tie plated.	Not tie plated.	Tie plated.
														Cost.	Cost.	Cost.	Cost.
120	377.2	\$12,448	31.60	\$1422	2.70	\$214	8	\$432	\$4160	\$1000	\$7500	\$27,176	\$28,976	\$5.15	\$5.49		
110	345.8	11,412	27.90	1224	2.54	200	8	432	4160	1000	7500	25,928	27,728	4.92	5.26		
100	314.2	10,372	23.00	1034	2.38	170	8	432	4160	1000	7500	24,668	26,468	4.68	5.02		
95	298.4	9,854	18.80	846	1.92	152	8	432	4160	1000	7500	23,944	25,744	4.54	4.88		
90	282.8	9,334	17.44	784	1.92	152	8	432	4160	1000	7500	23,362	25,162	4.43	4.77		
85	267.0	8,816	14.86	668	1.60	126	8	432	4160	1000	7500	22,702	24,502	4.30	4.64		
80	251.4	8,296	14.28	642	1.60	126	8	432	4160	1000	7500	22,156	23,956	4.19	4.53		
75	235.6	7,778	13.46	606	1.60	126	8	432	4160	1000	7500	21,602	23,402	4.09	4.43		
70	220.0	7,260	12.80	576	1.60	126	8	432	4160	1000	7500	21,054	22,854	3.99	4.33		
65	204.2	6,744	12.14	546	1.42	112	8	432	4160	1000	7500	20,494	22,294	3.88	4.22		
60	188.6	6,232	10.00	450	1.42	112	8	432	4160	1000	7500	19,886	21,686	3.77	4.11		
56	176.0	5,808	5.14	232	1.42	112	8	432	4160	1000	7500	19,244	21,044	3.64	3.98		

TABLE 7a.—DOUBLE TRACK: GRAVEL BALLAST.

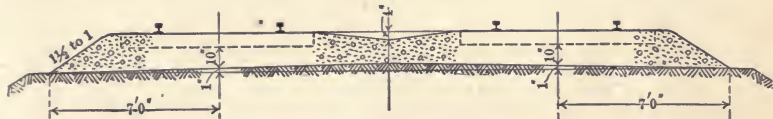

Wt. of rail.	Rails at \$33 ton.		Joint bars at \$45 ton.		Bolts at \$79 ton.		Spikes at \$54 ton.		Ties, 6400 at 65¢ each.	Labor, \$1000 per mile.	Ballasting and surfacing.	Cost per mile.		Cost per foot.			
	Tons.	Cost.	Tons.	Cost.	Tons.	Cost.	Tons.	Cost.				Cost.	Cost.	Not tie plated.	Tie plated.	Not tie plated.	Tie plated.
														Cost.	Cost.	Cost.	Cost.
120	377.2	\$12,448	31.60	\$1422	2.70	\$214	8	\$432	\$4160	\$1000	\$3000	\$22,676	\$24,476	\$4.30	\$4.64		
110	345.8	11,412	27.00	1224	2.54	200	8	432	4160	1000	3000	21,428	23,228	4.06	4.40		
100	314.2	10,372	23.00	1034	2.38	170	8	432	4160	1000	3000	20,166	21,966	3.72	4.16		
95	298.4	9,852	18.80	846	1.92	152	8	432	4160	1000	3000	19,442	21,242	3.68	4.02		
90	282.8	9,334	17.44	784	1.92	152	8	432	4160	1000	3000	18,862	20,662	3.58	3.92		
85	267.0	8,816	14.86	668	1.60	126	8	432	4160	1000	3000	18,202	20,002	3.45	3.79		
80	251.4	8,296	14.28	642	1.60	126	8	432	4160	1000	3000	17,656	19,456	3.35	3.69		
75	235.6	7,778	13.46	606	1.60	126	8	432	4160	1000	3000	17,102	18,902	3.24	3.58		
70	220.0	7,260	12.80	576	1.60	126	8	432	4160	1000	3000	16,554	18,354	3.14	3.48		
65	204.2	6,742	12.14	546	1.42	112	8	432	4160	1000	3000	15,992	17,792	3.03	3.37		
60	188.6	6,230	10.00	450	1.42	112	8	432	4160	1000	3000	15,384	17,184	2.91	3.25		
56	176.0	5,808	5.14	232	1.42	112	8	432	4160	1000	3000	14,744	16,544	2.80	2.94		

16 MATERIAL REQUIRED FOR TURNOUTS AND COST.

Turnouts.

TABLE 8. — APPROXIMATE QUANTITIES OF RAIL AND FASTENINGS, GROSS TONS FOR NO. 9.

Material.	Weight of rail, pounds.									
	56	60	65	70	75	80	85	90	95	100
Rail.....	3.58	3.83	4.15	4.46	4.78	5.10	5.42	5.74	6.06	6.38
Angle bars.....	0.25	0.25	0.25	0.26	0.28	0.29	0.30	0.31	0.32	0.33
Bolts.....	0.03	0.03	0.03	0.03	0.03	0.03	0.03	0.04	0.04	0.04
Spikes.....	0.20	0.20	0.20	0.20	0.20	0.20	0.20	0.22	0.24	0.25

Tie plates. Order 200.  
 Switch material. Order complete switch and frog with guard rails.  
 Switch ties. Order complete set of switch ties.

In the above turnouts it is assumed that the material will furnish a complete turnout covering 100 ft. of main line track and 100 ft. of siding track. (Fig. A.)

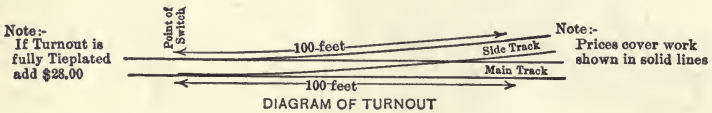

Fig. A.

TABLE 9. — APPROXIMATE COST OF TURNOUTS FOR VARIOUS WEIGHTS OF RAIL WITH GRAVEL OR STONE BALLAST. BASE OF RAIL 18 IN. ABOVE SUBGRADE.

Weight of rail, lb. per yard.	Rail at \$33 per ton.		Switch and frog material.	Fastenings (angle bars, bolts and spikes).	Switch ties, oak at \$30 per 1000.	Labor.	Gravel ballast 120 c. y. at 50¢.		Stone ballast 100 c. y. at \$1.25.	
	Tons.	Cost.					Cost.	Cost.	Ballast-ing.	Total cost.
56	3.58	\$118	\$ 90	\$19	\$101	\$60	\$60	\$448	\$125	\$513
60	3.93	126	105	23	101	60	60	475	125	540
65	4.15	137	112	25	101	60	60	495	125	560
70	4.46	147	114	25	101	60	60	507	125	572
75	4.78	158	116	26	101	60	60	521	125	586
80	5.10	168	116	27	101	60	60	532	125	597
85	5.42	179	139	27	101	60	60	566	125	631
90	5.74	189	143	28	101	60	60	581	125	645
95	6.05	200	148	29	101	60	60	598	125	663
100	6.38	211	152	36	101	60	60	620	125	685

The above are figured for No. 9 turnouts, for No. 7 deduct 15% and for No. 11 add 15%. (Fig. A.)



Crossovers.

TABLE 10.—APPROXIMATE COST OF CROSSOVERS FOR VARIOUS WEIGHTS OF RAIL INCLUDING RESURFACING.

(Track 13 ft. Centers.)

Weight of rail, lbs.	Rail at \$33 per ton.	Switch and frog material.	Fastenings (angle bars, bolts, spikes).	Turnout, ties, etc.	Track ties.	Labor and surfacing.	Total cost.
65	\$274	\$224	\$50	\$202	\$15	\$130	\$895
70	294	228	52	202	15	130	921
75	316	232	54	202	15	130	949
80	336	236	56	202	15	130	975
85	358	278	58	202	15	130	1041
90	378	286	60	202	15	130	1071
95	400	296	62	202	15	130	1105
100	422	304	72	202	15	130	1145

The above are figured for No. 9 turnouts; for No. 7 deduct 15% and for No. 11 add 15%.

Example:

What is the detailed cost of a No. 9 single track crossover; 85 lb. steel, not tie plated? Table 10, under 85 lb. rail.

Rail .....	\$358
Switch and frog material.....	278
Angle bars, bolts, and spikes.....	58
Turnout ties.....	202
Track ties.....	15
Labor and surfaces .....	130
	<u>\$1041</u>
Supervision and contingencies, 10%.....	104
Total.....	<u>\$1145</u>

TABLE 11.—APPROXIMATE COST OF SWITCH TIES FOR CROSSOVERS.

CROSSOVER TIES.

Number of turnout.	Track centers, ft.	F. B. M.	Approximate cost.		
			\$22 per M.	\$25 per M.	\$30 per M.
7..... C. P.	13	6095 (15 or 16½ ft. split switch)	\$134	\$153	\$183
8. A. R. E. A.	13	6925 (15 or 16½ ft. split switch)	153	173	208
9..... C. P.	13	6725 (15 or 16½ ft. split switch)	148	178	202
11. A. R. E. A.	13	9534 (22 ft. switch) .....	210	239	286
9..... C. P.	14	6725 (15 or 16½ ft. split switch)	148	169	202
9..... C. P.	15	7088 (15 or 16½ ft. split switch)	157	179	213

**TRACK MATERIAL AND ESTIMATES.**

For making preliminary quick estimates of the approximate cost of spur tracks, the following tables and figures will be found very serviceable, the same unit prices for track material being used as quoted in the preceding estimates.

**Example:**

Find the approximate cost of constructing a 500 ft. spur on a 2 ft. fill main line 85 lb. rail, spur to be 65 lb. rail. (Turnout same weight as main line rail.)

**Estimate:**

85 lb. turnout, tie plated (Table a).....	\$596
500 ft. (less 200 ft. for turnout) 300 ft. 65 lb. track (Table b) @ \$1.56.....	468
500 ft. of fill (2 ft. high) \$71 by 5..... (Table c).....	355
<b>Total.....</b>	<b>\$1419</b>

TABLE a. — TURNOUTS.

TABLE b. — TRACKWORK.

Weight of rail, lb.	Cost of turnout.		Cost of track per foot.		Weight of rail, lb.
	Not tie plated.	Tie plated.	No. 1 ties and new rail.	No. 2 ties and relay rail.	
100	\$620	\$650	\$2.00	.....	100
95	598	628	1.89	\$1.40	95
90	581	611	1.83	1.35	90
85	566	596	1.78	1.30	85
80	532	562	1.72	1.25	80
75	521	551	1.66	1.20	75
70	507	537	1.62	1.15	70
65	495	525	1.56	1.10	65
60	475	505	1.50	1.05	60
56	448	478	1.44	1.00	56

Table a includes rail and fastenings, switch material, ties, ballast, labor, etc., complete in place for each turnout.

Table b includes rail, angle bars, bolts, spikes, ties and ballast complete in place for each weight of rail given with 7-in. ballast under tie.

TABLE c. — FILL. CUBIC YARDS FILL PER 100 FT. OF TRACK, 16 FT. SUBGRADE.

Fill.....	6 in.	1 ft.	1½ ft.	2 ft.	2½ ft.	3 ft.	3½ ft.	4 ft.	5 ft.	6 ft.	7 ft.	8 ft.
Cubic yards.....	32	66	102	142	184	228	276	326	436	556	688	930
Cost at 50¢ yd., \$.	16	33	51	71	92	114	138	163	218	278	344	465

**Tie Plates.** — Usually always provided for the switch leads, the turnout curve and the siding curves, 120 per 100 lineal feet.

**Ballast.** — 50 cubic yards per 100 feet allows for an average gravel ballast section 7 inches deep under the ties.

**Rail and Turnout.** — 100 feet of main track and 100 feet of siding comprises the turnout Fig. A, page 16, and in the case of a new spur or siding the 100 feet of main line rail released may be laid on the reverse curve back of the turnout, hence considering

the turnout as furnishing 100 feet, and the released main line rail 100 feet, the siding rail to be figured will be reduced by 200 feet for each.

**Signals.** — In block signal territory \$250.00 may be added to the estimate for changes due to the introduction of one switch in the main track, and \$175.00 for a trailing point switch in double track territory.

**Culverts.** —

Concrete pipe.			Cast iron pipe.			Ordinary wood boxes.		
Size, inches.	Cost per foot.	Add for wing walls, concrete.	Size, inches.	Cost per foot.	Add for wing walls, rip rap.	Size, feet.	Cost per foot.	Add for wing walls.
18	\$2.20	\$30	18	\$5.00	\$15	1 × 2	\$1.00	.....
24	2.50	40	24	7.75	18	2 × 2	1.50	.....
30	2.75	50	30	10.00	21	2 × 3	2.50	\$16
36	3.00	60	36	12.00	24	3 × 4	3.00	24

**Telegraph Poles:**

Cost of removing	1 to 4 poles	.....	\$20.00 per pole
	4 to 8 "	.....	17.50 "
	8 to 12 "	.....	15.00 "
	12 or more "	.....	10.00 "

**Car Stops: installed complete in place.**

Earth or cinder stop, banked up	.....	\$15.00
Earth or cinder wood frame	.....	30.00
Cast iron stop block (small size)	.....	45.00
Ellis type stop block	.....	100.00

**Cattle Guards:**

Cattle guards, surface	.....	35.00
" crib	.....	40.00
" pit	.....	75.00

**Compromise Angle Bars:**.....per pair 1.50 to 2.00

**Track Ties.** — A fair average price is 65 cents each delivered along the track, and figuring 3200 to the mile the cost would be \$2080 per mile for new main line single track.

For maintenance work about 10 per cent is a fair average for renewals, or 300 per mile costing \$195. For side tracks 5 per cent is a good average or 150 per mile; for the latter, however, second class and cull ties are used ranging from 30 to 50 cents each or an average of 40 cents or \$60 per mile.

**Labor.** — Putting in ties for ordinary track, a common figure for estimating is 12 cents per lineal foot for single track.

**Ballasting and Surfacing.** — Gravel ballast 10 inches under ties, 30 cents per lineal foot for single track. Stone ballast 7 inches under ties, 75 cents per lineal foot for single track.

20 TRACK MATERIAL PER 100 FT. AND PER MILE.

TABLE 12.—APPROXIMATE QUANTITIES PER 100 FEET OF SINGLE TRACK. RAILS, FASTENINGS, ETC., GROSS TONS.

Material.	Various weights of rails in pounds.									
	100	95	90	85	80	75	70	65	60	56
Rail.....	2.98	2.83	2.68	2.53	2.38	2.23	2.09	1.93	1.78	1.67
Angle bars	0.21	0.18	0.16	0.141	0.149	0.13	0.12	0.114	0.104	0.05
Bolts.....	0.022	0.018	0.016	0.015	0.017	0.013	0.012	0.014	0.014	0.014
Spikes.....	0.075	0.075	0.075	0.075	0.075	0.075	0.075	0.075	0.075	0.075
Tie plates.	120 per 100 ft.									
Ties.....	60 per 100 ft.									
Ballast....	60 cu. yd. per 100 ft.									

**Example:**

What quantity of material is required for 400 ft. of single line track; 85 lb. steel, not tie plated? From Table 12 under 85 lb. rail.

Rail.....	2.53	× 4 =	10.12	gross tons.
Angle bars.....	0.141	× 4 =	0.564	“ “
Bolts.....	0.015	× 4 =	0.06	“ “
Spikes.....	0.075	× 4 =	0.30	“ “
Ties.....	60	× 4 =	240	ties.
Ballast.....	60	× 4 =	240	cu. yds.

TABLE 12a.—APPROXIMATE QUANTITIES PER MILE OF SINGLE TRACK. RAILS, FASTENINGS, ETC., GROSS TONS.

Material.	Various weights of rails in pounds.									
	100	95	90	85	80	75	70	65	60	56
Rail.....	157.14	149.29	141.43	133.57	125.71	117.85	110.00	102.14	94.29	88.00
Angle bars...	11.5	9.4	8.72	7.43	7.14	6.73	6.40	6.07	5.00	2.57
Bolts....	1.19	0.96	0.96	0.80	0.80	0.80	0.80	0.71	0.71	0.71
Spikes...	4.0	4.00	4.00	4.00	4.0	4.00	4.00	4.0	4.0	4.0
Tieplates	6000 per mile.									
Ties.....	3000 per mile.									
Ballast..	3000 cu. yd. per mile.									

**Example:**

What quantity of material is required for 3 miles of single line track; 90 lb. steel, tie plated? From Table 12a, under 90 lb. rail.

Rail.....	141.43	× 3 =	424.29	gross tons.
Angle bars.....	8.72	× 3 =	26.16	“ “
Bolts.....	0.96	× 3 =	1.98	“ “
Spikes.....	4.00	× 3 =	12.00	“ “
Tie plates.....	6000	× 3 =	18,000	plates
Ties.....	3000	× 3 =	9,000	ties
Ballast.....	3000	× 3 =	9,000	cu. yds.

Rail Renewals.

TABLE 13.—COST AND CREDIT PER MILE FOR VARIOUS WEIGHTS OF RAIL.  
ESTIMATED COST OF NEW AND SECOND HAND RAILS AND FASTENINGS PER MILE OF TRACK,  
AND CREDIT FOR THE SAME WHEN REMOVED.

Weight of rail.	Kind of rail.	Rail.			Fish plates or angle bars.			Bolts.			Spikes.			Total.
		Tons.	Price.	Cost.	Tons.	Price.	Cost.	Tons.	Price.	Cost.	Tons.	Price.	Cost.	
lb.			\$	\$		\$	\$		\$	\$		\$	\$	\$
48	New.....	75.43	33	2489.19	2.64	45	118.80	0.78	79.00	61.62	4	54	216	2885.61
	Second hand.	75.43	20	1508.60	2.64	35	92.40	0.39	68.00	26.52	4	54	216	1874.33
	Credit.....	75.43	20	1508.60	2.64	35	92.40	0.39	79.00	30.81	3	54	162	1789.52
52	New.....	81.71	33	2696.43	2.83	45	127.35	0.78	79.00	61.62	4	54	216	3101.40
	Second hand.	81.71	20	1634.20	2.83	35	99.05	0.39	68.00	26.52	4	54	216	2006.58
	Credit.....	81.71	20	1634.20	2.83	35	99.05	0.39	79.00	30.81	3	54	162	1921.77
56	New.....	88.00	33	2904.00	2.83	45	127.35	0.78	79.00	61.62	4	54	216	3308.97
	Second hand.	88.00	20	1760.00	2.83	35	99.05	0.39	68.00	26.52	4	54	216	2132.38
	Credit.....	88.00	20	1760.00	2.83	35	99.05	0.39	79.00	30.81	3	54	162	2047.57
60	New.....	94.20	33	3108.60	5.49	45	247.05	0.80	79.00	63.20	4	54	216	3634.85
	Second hand.	94.20	20	1884.00	5.49	35	192.15	0.40	68.00	27.20	4	54	216	2350.95
	Credit.....	94.20	20	1884.00	5.49	35	192.15	0.40	79.00	31.60	3	54	162	2265.35
65	New.....	102.17	33	3371.61	7.04	45	316.80	0.74	79.00	58.46	4	54	216	3962.87
	Second hand.	102.17	20	2043.40	7.04	35	246.40	0.37	68.00	25.16	4	54	216	2560.19
	Credit.....	102.17	20	2043.40	7.04	35	246.40	0.37	79.00	29.23	3	54	162	2476.96
72	New.....	113.14	33	3733.62	12.26	45	551.70	1.26	79.00	99.54	4	54	216	4600.86
	Second hand.	113.14	20	2262.80	12.26	35	429.10	0.63	68.00	42.84	4	54	216	3000.51
	Credit.....	113.14	20	2262.80	12.26	35	429.10	0.63	79.00	49.77	3	54	162	2896.74
73	New.....	114.71	33	3785.43	8.17	45	367.65	0.84	79.00	66.36	4	54	216	4435.44
	Second hand.	114.71	20	2294.20	8.17	35	285.95	0.42	68.00	28.56	4	54	216	2857.89
	Credit.....	114.71	20	2294.20	8.17	35	285.95	0.42	79.00	33.18	3	54	162	2770.71
80	New.....	125.71	33	4148.43	7.86	45	353.70	0.88	79.00	69.52	4	54	216	4787.65
	Second hand.	125.71	20	2514.20	7.86	35	275.10	0.44	68.00	29.92	4	54	216	3069.98
	Credit.....	125.71	20	2514.20	7.86	35	275.10	0.44	79.00	34.76	3	54	162	2981.22
85	New.....	133.57	33	4407.81	7.43	45	334.35	0.80	79.00	63.20	4	54	216	5021.36
	Second hand.	133.57	20	2671.40	7.43	35	260.05	0.40	68.00	27.20	4	54	216	3206.25
	Credit.....	133.57	20	2671.40	7.43	35	260.05	0.40	79.00	31.60	3	54	162	3120.65
100	New.....	157.14	33	5185.62	15.71	45	706.95	1.19	79.00	94.01	4	54	216	6202.58
	Second hand.	157.14	20	3142.80	15.71	35	549.85	0.60	68.00	40.80	4	54	216	3996.06
	Credit.....	157.14	20	3142.80	15.71	35	549.85	0.59	79.00	46.61	3	54	162	3895.45

From the foregoing table, the capital and maintenance charges can be easily figured, for replacing old rail with new rail or old rail with heavier second hand rail for the unit prices given.

Example.—What is the cost of renewing 80 lb. with new 85 lb. rail and state how much is chargeable to capital and how much to maintenance?

New 85 lb. rail and fastenings from table.....	\$5021.36
Credit old 80 " " " " " " .....	2981.22
	\$2040.14 = total charge.
Cost of new 85 lb. rail, etc., less cost of new 80 lb. rail, etc.,	
= \$5021.36 - \$4787.65 from table = .....	233.71 = cap. charge.
	Difference \$1806.43 = maint'ce charge.

NOTE.—The above covers rail fastenings only; to the maintenance charge would be added labor replacing and any tie renewals.

SWITCH TIES FOR VARIOUS TURNOUTS.

TABLE 14. — BILL OF SWITCH TIES FOR VARIOUS TURNOUTS. (C. P. R.)

Size and length of ties.	15 or 16½ ft. split switches.						Stub switch.*		(10 or 11 ft.) Yard split switch.	
	Number of pieces required for each turnout.						Number of pieces for each turnout.			
	Frog numbers.						Frog numbers.		Frog numbers.	
	No. 7.	No. 8.	No. 9.	No. 10.	No. 11.	No. 12.	No. 7.	No. 9.	No. 7.	No. 9.
7×9 8 0	3	3	3	3	3	3	...	...	3	3
7×9 8 6	9	10	10	10	10	10	9	9	6	7
7×9 9 0	6	6	6	6	6	5	4	6	5	6
7×9 9 6	3	3	4	5	6	6	4	4	3	4
7×9 10 0	3	3	4	4	5	6	3	4	2	3
7×9 10 6	3	3	3	4	3	3	2	4	2	3
7×9 11 0	2	3	3	3	4	4	3	3	2	3
7×9 11 6	2	2	3	3	3	4	2	2	2	2
7×9 12 0	2	2	2	3	3	3	2	3	2	2
7×9 12 6	2	3	3	3	3	4	2	3	2	3
7×9 13 0	2	2	3	3	4	4	2	3	3	3
7×9 13 6	2	3	3	3	3	4	2	3	2	3
7×9 14 0	2	2	2	3	3	3	3	2	2	2
7×9 14 6	2	2	2	2	3	3	2	3	2	3
7×9 15 0	2	2	2	3	3	3	1	1	...	...
7×9 15 6	2	2	3	2	2	3	...	...	...	...
7×9 16 0	3*	2	3	2	2	2	...	...	2	2
Total.....	50	53	59	62	66	70	41†	50†	40	49
Lineal feet....	557½	587	662½	692	739½	793½	445½	546	438½	537½
Feet B. M....	2927	3082	3478	3633	3882	4166	2339	2867	2302	2822

\* Totals for stub switch turnouts do not include headblock. One 8" × 14" × 15' required for each.

TABLE 14a. — APPROXIMATE COST OF SWITCH TIES. SWITCH TIES (15 OR 16½ FT. SPLIT SWITCHES).

Number of turnout.	F. B. M.	Approximate cost.				
		\$22 per M.	\$25 per M.	\$30 per M.	\$35 per M.	
7.....	C. P.	2,927	\$65	\$74	\$88	\$103
8.....	C. P.	3,082	68	77	93	108
9... N. Y. C. & H. R.		3,269	72	82	98	115
9.....	C. P.	3,478	76	87	104	122
10.....	C. P.	3,633	80	91	109	128
11.....	C. P.	3,882	86	97	117	136
12.....	C. P.	4,166	92	104	125	146

SLIP SWITCH TIES.

Number of turnout.	F. B. M.	Approximate cost.				
		\$22 per M.	\$25 per M.	\$30 per M.	\$35 per M.	
7.....	C. P.	4,600	\$102	\$115	\$138	\$161
8.....	A. R. E. A.	5,828	129	146	175	204
9.....	C. P.	6,900	152	173	207	242
11.....	A. R. E. A.	7,182	158	180	216	251
16.....	A. R. E. A.	10,064	222	252	302	352



## CHAPTER II.

## STRUCTURAL MATERIAL AND ESTIMATES.

TABLE 16. BUILDINGS AND MISCELLANEOUS.

(C. P. R. estimating prices, 1915.)

The following prices for buildings are an average of a number built on Eastern Lines under normal conditions with ordinary foundations, and are intended only as a guide; when estimating, the figures must be checked by local officers and may be varied to suit actual conditions.

(A) Ash pits, two track (drain not included) .....	\$3,750.00
Ash pit, 30 ft. long, concrete with firebrick lining .....	400.00
(B) 1 boiler and stack (1-100 H. P.) with foundation and concrete supports.....	2,500.00
2 boilers and stack (2-100 H. P.) with foundation and concrete supports.....	5,000.00
Boiler house and machine shop (equipment not included) . . .	10,000.00
Bunk house No. 1 .....	4,500.00
" " portable.....	300.00
" " No. 3.....	600.00
" " No. 4.....	1,000.00
(C) Coaling plant, two track complete with approach .....	13,500.00
" " three " " " " .....	16,500.00
Cottages (double), concrete foundation (no drainage included).....	7,500.00
Charcoal house.....	500.00
Coal and oil house.....	250.00
Commercial coal shed.....	600.00
Cattle guards, per set, for single track.....	16.00
(D) Depot scales, 3 ton.....	275.00
(E) Engine house (85 ft.), drain not included, per stall.....	3,500.00
" " (90 ft.) " " " " .....	3,750.00
Electric light standards for station platforms, each (no wiring)	
Type A.....	50.00
Type B.....	30.00
Type C.....	15.00
(F) Freight shed, 50 ft. any floor, per square foot .....	1.35
" " 40 ft. " " " " .....	1.45
" " 30 ft. with continuous sliding doors, any floor .	1.60
" " 30 ft. with platform, any floor, per square foot	1.50
Fencing — 7 wire fence, per rod.....	0.75
Permanent snow fence, per foot .....	0.35
Portable " " " " .....	0.25
Corrugated iron, not including painting, per foot	1.50
(G) Gates, pipe braced farm gates, each in place.....	5.00
Wire " " " " " " .....	4.25
(I) Ice house, No. 2, without high platform.....	1,300.00
" No. 2, with " " .....	1,750.00
Inspection pit (concrete) for single track.....	1,000.00
(M) Machine shop and boiler house (equipment not included).	10,000.00



TABLE 16 (Continued).—BUILDINGS AND MISCELLANEOUS.

(P) Pump house No. 2 (not including pump, boiler or stack) . . . . .	\$700.00
Privy No. 2 . . . . .	75.00
Privy for passenger stations . . . . .	130.00
“ “ section houses . . . . .	100.00
Paving, scoria blocks on sand bed, jointed with sand, per sq. yard . . . . .	2.40
“ scoria blocks on concrete foundation, jointed with sand, per sq. yard . . . . .	3.40
“ scoria blocks on concrete foundation, jointed with cement, per sq. yard . . . . .	3.50
“ granite sets on sand bed, jointed with sand, per sq. yard . . . . .	2.00
“ granite sets on concrete foundation, jointed with sand, per sq. yard . . . . .	3.00
“ granite sets on concrete foundation, jointed with cement, per sq. yard . . . . .	3.25
(S) Stand pipe (10 in.) with pit, not including supply pipe or drainage . . . . .	700.00
Sand house for two tracks . . . . .	1,800.00
“ “ “ three “ . . . . .	2,000.00
Scales track, 100 ton (complete but no drainage included) . . . . .	3,750.00
“ depot, 3 ton . . . . .	300.00
“ wagon, 10 ton, with compound beam scales . . . . .	600.00
Store and oil house No. 7, 30 ft. × 60 ft., with Bowser equipment, air hoist . . . . .	6,500.00
Store and oil house No. 8, 30 ft. × 30 ft., with Bowser equipment, air hoist . . . . .	4,500.00
Store and oil house No. 9, 20 ft. × 30 ft., with Bowser equipment, air hoist . . . . .	3,750.00
Section house No. 2 — single . . . . .	1,200.00
“ “ No. 4 — “ . . . . .	1,900.00
“ “ No. 3 — double . . . . .	4,200.00
Stations (No. 2), concrete foundations, hot water heating and electric light (no furnishings included) . . . . .	7,000.00
Stations (No. 5), concrete foundations, hot water heating and electric light (no furnishings included) . . . . .	5,000.00
Stations (No. 6), concrete foundations, hot water heating and electric light (no furnishings included) . . . . .	900.00
Station, portable . . . . .	600.00
Station platforms, wood, per square foot . . . . .	15c. to 18c.
“ “ concrete, per square foot . . . . .	20c. to 30c.
“ “ high freight, wood, per square foot . . . . .	18c. to 25c.
Shelter, not enclosed 50 ft. × 8 ft. platform . . . . .	350.00
“ semi-enclosed 50 ft. × 8 ft. “ . . . . .	400.00
“ No. 2 semi-enclosed 50 ft. × 8 ft. “ . . . . .	600.00
“ No. 2 enclosed 50 ft. × 6 ft. “ . . . . .	275.00
“ No. 3 enclosed 60 ft. × 6 ft. “ . . . . .	550.00
“ special semi-enclosed 50 ft. × 8 ft. “ . . . . .	260.00
(T) Tank 40,000 gallon, erected complete . . . . .	3,500.00
“ 60,000 “ “ “ . . . . .	4,500.00
Turntable (80 ft.) with circle wall and pier (no drain included) . . . . .	9,000.00
Track scales, 100 ton (complete but no drainage included) . . . . .	3,750.00
Tool house No. 2, single . . . . .	90.00
“ “ “ double . . . . .	175.00
“ “ No. 3 (for maintainers of automatic signals) . . . . .	180.00
(W) Wagon scales, 10 ton, with compound beam scales . . . . .	600.00

# 26 PRELIMINARY ESTIMATING PRICES FOR BUILDINGS.

## TABLE 17. — BUILDINGS.

PRELIMINARY 1915 ESTIMATING PRICES FOR AVERAGE STATION WORK.

The figures given include labor and material for the work in place.

<b>Excavation:</b>		<b>Floors and Roof Work:</b>	
Piling, cu. yd. ....	\$0.50	Terrazzo, cover only, sq. ft. ....	\$0.20
Conc. piles, first 20 ft. per ft. ....	1.00	Mastic cushion type cover only, sq. ft. ....	0.22
“ “ additional length per ft. ....	0.80	Bitumen cover only, sq. ft. ....	0.10
<b>Brickwork:</b>		Wood under floors, M. ....	30.00
Brick in wall (common) per M. ....	19.00	“ sleepers, M. ....	35.00
“ ext. face per M. ....	45.00	Roof framing, M. ....	30.00
“ int. “ per M. ....	60.00	“ sheathing, M. ....	30.00
<b>Concrete Work:</b>		Oak floors laid & scraped, sq. ft. ....	0.25
Concrete 1 : 2 : 3, plain, cu. yd. ....	6.00	Birch floors laid & scraped, sq. ft. ....	0.11
“ “ reinforced, cu. yd. ....	12.00	Copper cornice, lin. ft. ....	1.00
“ “ tile reinforced, sq. ft. ....	0.30	Copper roofing, square. ....	38.00
“ “ fill cinder, cu. ft. ....	0.12	Composition roof laid, square. ....	5.00
“ “ slabs on hy. rib metal (2 in.),		<b>Carpentry and Joiner Work:</b>	
sq. ft. ....	0.10	D. H. frame & sash wood, daylight	
Cement finish (1 in.), sq. ft. ....	0.07	opening, sq. ft. ....	0.80
Granolithic sidewalk conc. & topping,		Casement frame & sash, daylight	
sq. yd. ....	1.80	opening, sq. ft. ....	0.70
<b>Terra Cotta Work:</b>		Interior frames & sash, daylight open-	
Terra cotta (3 in.) sq. ft. ....	0.11	ing, sq. ft. ....	0.80
“ “ (4 in.) “ ....	0.12	Door & transom, pine, each. ....	18.00
“ “ (6 in.) “ ....	0.15	“ “ oak, each. ....	20.00
“ “ (8 in.) “ ....	0.17	“ “ with trim, pine, each. ....	22.00
“ “ (12 in.) “ ....	0.25	“ “ oak, each. ....	25.00
<b>Stonework:</b>		Door without transom with trim, pine,	
Granite ashlar, sup. ft. ....	1.25	each. ....	20.00
“ “ cut & molded, cu. ft. ....	3.00	Door without transom with trim, pine,	
Limestone ashlar, sup. ft. ....	1.00	each. ....	22.00
“ “ cut & moulded, cu. ft. ....	2.25	Base set, lin. ft. ....	0.30
<b>Structural Steel:</b>		Chair rail, set, lin. ft. ....	0.15
Structural steel (delivered), per lb. ....	0.4½	Picture mold, set, lin. ft. ....	0.10
“ “ (delivered & erected),		Wainscot, sq. ft. ....	1.25
per lb. ....	0.5½	<b>Glazing Work:</b>	
<b>Plaster Work:</b>		Plate glass, sq. ft. ....	0.50
Metal furring, not including lath, sq. ft. ....	0.03	“ “ wire, sq. ft. ....	0.90
Metal furring, including lath, sq. ft. ....	0.06	Glass, silver ripple, sq. ft. ....	0.25
Corner bead in place, lin. ft. ....	0.06	“ “ 26 oz., sq. ft. ....	0.25
Plaster on metal lath, 3 coats, sq. yd. ....	0.40	Skylights inst'd incl'g glass & glazing,	
“ “ terra cotta, 2 coats, sq. yd. ....	0.35	sq. ft. ....	1.25
“ “ molded work, incl. furring,		<b>Paint Work:</b>	
sq. ft. ....	0.45	Stain & fill (3 coats varnish & finish),	
Plaster (cement), 3 coats, sq. yd. ....	0.50	sq. yd. ....	0.50
“ “ 1 coat, sq. yd. ....	0.30	3 coats lead & oil, sq. yd. ....	0.30
<b>Marble Work:</b>		Canvas dado & 3 coats lead oil, sq. yd. ....	0.70
Marble dado & partition, sq. ft. ....	1.25	Metal weather strip in place, lin. ft. ....	0.10
“ floors, sq. ft. ....	0.60	<b>Timber:</b>	
“ base, sq. ft. ....	1.00	White pine boards per M. ....	\$27 to \$32
		Hemlock & chestnut boards per M. ....	18 to 20
		Douglas fir boards per M. ....	30 to 37
		Yellow poplar boards per M. ....	50 to 68
		Red or gulf cypress boards per M. ....	43 to 63

Building Construction.

TABLE 18.—BUILDING LIVE LOADS AND SAFE BEARING VALUES.

Classes of buildings	Live loads in pounds.		
	Distributed loads.	Concentrated loads.	Load per lineal foot of girder.
	a	b	c
Stations, hotels, boarding houses, etc.	40	2,000	500
Dwellings	60		
Theaters, churches, schools, etc., with fixed seats	40	5,000	1000
Ballrooms, armories, gymnasiums, etc.	80	5,000	1000
Stock pens, stables, carriage houses	70	5,000	1000
Stores and light manufacturing	40	8,000	1000
Sidewalks in front of buildings	100	10,000	
Freight sheds, warehouses, factories	120 up	Special	Special
Charging rooms for foundries	300 up	Special	Special
Power houses	200 up	Special	Special
Station platforms	100	2,000	500
Express and baggage rooms	100	2,000	500
Offices	40	5,000	1000

a = A uniform load per square foot of area.

b = A concentrated load which shall be applied at all points of the floor.

c = A uniform load per lineal foot for girders.

The maximum result is to be used in calculations, special machinery or concentrations to be figured when such occur.

Crane loads, etc.: For structure carrying crane loads, traveling conveyors, etc., 25 per cent shall be added to the stresses resulting from such live load to provide for the effects of impact and vibrations.

SAFE BEARING POWER OF SOILS.

Kind.	Minimum.	Maximum.	Allowable pressure in tons per square foot.
Rock	10	2000	
Hard clay and firm coarse sand			4
Clay in thick beds always dry	4	6	
Clay in thick beds moderately dry	2	4	
Clay soft	1	2	1
Clay mixed with sand			2
Clay dry and dry sand			3
Gravel and coarse sand well cemented	8	10	
Sand compact and well cemented	4	6	
Sand clean dry	2	4	
Firm coarse sand and gravel			6
Quick sand, alluvial soils, etc.	1/2	1	

Piles Eng. formula:

$$P = \frac{2WH}{S+1}$$

P = Safe load on piles in tons,

W = Weight of hammer in tons,

H = Distance of free fall of the hammer in feet,

S = Penetration of the pile for the last blow in inches.

(Factor of safety 6.)

Firm soil to rock max. load not to exceed 20 tons or 600 lb. per square inch.

Wet soil to rock figure as cols. with max. unit stress 600 lb. properly reduced.

Working pressures in masonry.	Tons per sq. ft.	Pressures in lb. per square inch.	Tons per sq. ft.
Brick common in Rosendale cement	10	Concrete (Portland cement)	230
Brick common in Portland cement	12	Concrete (Rosendale cement)	125
Brick hard burned in Portland cement	15	Stonework rubble laid in Portland cement	140
Masonry rubble Rosendale cement	8	Brickwork laid in Portland cement	250
Masonry rubble Portland cement	10	Brickwork laid in lime mortar	110
Masonry coursed rubble Portland cement	12	Granite	1000
Masonry first class sandstone	20	Limestone	700
Masonry first class limestone	25	Pedestals	250-300
Masonry first class granite	30	Wall plates:	
Concrete for walls:		Brickwork in cement mortar	200
Portland Cement 1-2-5	20	Masonry rubble in cement mortar	200
Portland Cement 1-2-4	25	Concrete Portland cement	350
		Sandstone first class	400
		Limestone first class	500
		Granite	600

TABLE 18a. — LIVE AND DEAD ROOF LOADS.

Approximate weight of roof covering.	Least pitch.	Lb. per square foot.
Tar and gravel (felt and asphalt with gravel).....	$\frac{3}{4}$ in. to the ft.	9
Prepared roofing or asphalt on inclined roof.....		6
Shingles with building paper under.....	$\frac{1}{2}$ span	.....
Slates on laths.....	$\frac{1}{2}$ span	9
Asbestos slates on laths.....	$\frac{1}{2}$ span	8
Tile flat.....		20
Tile corrugated.....		10
Tin (Canada plate).....	$\frac{3}{4}$ in. to the ft.	2
Iron (corrugated).....	$\frac{1}{2}$ span	1-2
1-in. boarding.....		3-4
Plaster ceiling.....		8-10
Felt and asphalt.....		2
1-in. gravel or stone concrete with steel reinforcement.....		13
1-in. cinder concrete with steel reinforcement.....		9
$\frac{1}{2}$ -in. skylights with gal. iron frames.....		8
Steel trusses.....		2-6 $\frac{1}{2}$
Steel purlins and connections.....		2-4
Concrete slabs.....		.....
Reinforced concrete.....		.....

Live and Dead Loads Combined.	Lb. per sq. ft.
Gravel or composition roofing on boards, flat pitch, 3 to 12 or less.....	45
Gravel or composition roofing on boards, steep more than 3 to 12.....	40
Gravel or composition roofing on boards 3-in. flat tile or cinder concrete.....	55
Corrugated sheeting on boards or purlins.....	50
Slate on boards or purlins.....	50
Slate on 3-in. flat tile or cinder concrete.....	65
Tile on steel purlins.....	55

## ROOFS: LIVE LOADS.

Flat roofs of office buildings, hotels, dwellings, etc., which are likely to be loaded by crowds of people shall be treated as floors and the same live load shall be as specified for floors.

Engine houses, train sheds, shops, etc., shall be proportioned to carry in addition to their own weight a live load representing wind and snow as follows, including the possibility of a partial snow load to obtain maximum stresses.

## WIND AND SNOW.

*Snow:*

Flat roofs west of Fort William (hor. proj.).....	30
Inclined roofs west of Fort William (hor. proj.).....	20

*Wind:*

Inclined roofs horizontal pressure.....	30
---	----

(Figure for normal component.)

## NORMAL PRESSURES FOR VARIOUS ANGLES.

Angle.	Pressure.	Angle.	Pressure.
5	4	25	17
10	7 $\frac{1}{2}$	30	20
15	10 $\frac{1}{2}$	35	23
20	14	40	25
.....	.....	45	27
.....	.....	50	29
.....	.....	60	30

Pressure on vertical sides of buildings 30 lb. per square foot.

Railway Bridges.

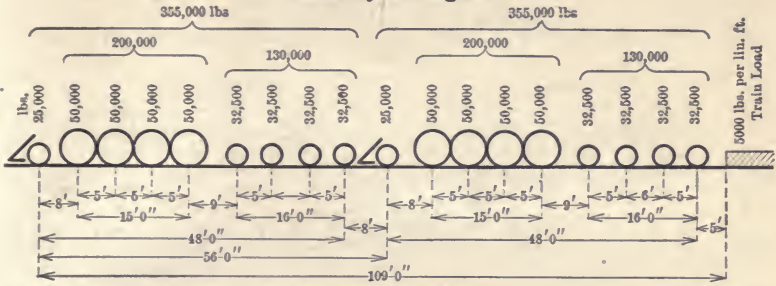

TABLE 19. — GENERAL DIMENSIONS AND WEIGHTS OF C. P. R. STANDARD SPANS FOR SINGLE TRACK.  
Live load (coopers E 50). Impact and wind as per specification.

Description.	Length over-all Steel work.	Depth of girder or truss back to back.	Distance C. to C.	Distance to base of rail.		Approx. weight (incl. floor iron).
				To underside of steel-work.	To bridge seat.	
	Ft. In.	Ft. In.	Ft. In.	Ft. In.	Ft. In.	Lb.
Deck I span:						
13 ft.....	16 0	1 8	{ 2 6 inner I <sup>s</sup>	2 3 <sup>1</sup> / <sub>2</sub>	2 4 <sup>1</sup> / <sub>2</sub>	6,000
15 ft.....	17 6	2 0	{ 7 6 outer I <sup>s</sup>	2 7 <sup>1</sup> / <sub>2</sub>	2 8 <sup>1</sup> / <sub>2</sub>	7,500
Deck P. G. span:			Ft. In.			
20 ft.....	23 4	3 0 <sup>1</sup> / <sub>4</sub>	9 0	4 2 <sup>1</sup> / <sub>2</sub>	4 4 <sup>1</sup> / <sub>2</sub>	14,300
30 ft.....	33 0	3 6 <sup>1</sup> / <sub>2</sub>	9 0	4 9 <sup>3</sup> / <sub>4</sub>	4 11	24,000
40 ft.....	42 10	4 6 <sup>1</sup> / <sub>2</sub>	9 0	5 9 <sup>3</sup> / <sub>4</sub>	5 11	35,000
50 ft.....	53 10	5 6 <sup>1</sup> / <sub>2</sub>	9 0	6 9 <sup>3</sup> / <sub>4</sub>	6 11 <sup>1</sup> / <sub>4</sub>	49,000
60 ft.....	65 4	6 0 <sup>1</sup> / <sub>2</sub>	9 0	7 5	7 10	73,000
70 ft.....	74 10	7 0 <sup>1</sup> / <sub>2</sub>	9 0	8 5	9 0 <sup>3</sup> / <sub>4</sub>	88,000
80 ft.....	85 4	8 0 <sup>1</sup> / <sub>2</sub>	9 0	9 5 <sup>3</sup> / <sub>4</sub>	10 0 <sup>3</sup> / <sub>4</sub>	115,000
100 ft.....	102 9	10 0 <sup>1</sup> / <sub>2</sub>	9 0	11 6 <sup>1</sup> / <sub>4</sub>	12 4	170,000
Half deck P. G. span:						
20 ft.....	23 4	3 0 <sup>1</sup> / <sub>2</sub>	13 0	1 5 <sup>1</sup> / <sub>4</sub>	1 7 <sup>3</sup> / <sub>4</sub>	14,500
30 ft.....	33 0	3 6 <sup>1</sup> / <sub>2</sub>	13 0	1 5 <sup>1</sup> / <sub>4</sub>	1 7 <sup>3</sup> / <sub>4</sub>	23,000
40 ft.....	42 10	4 4 <sup>1</sup> / <sub>2</sub>	13 0	1 6 <sup>1</sup> / <sub>5</sub>	1 7 <sup>3</sup> / <sub>4</sub>	37,500
50 ft.....	53 10	5 0 <sup>1</sup> / <sub>2</sub>	13 0	2 3 <sup>3</sup> / <sub>4</sub>	2 4	54,000
60 ft.....	65 4	6 0 <sup>1</sup> / <sub>2</sub>	13 0	3 5 <sup>1</sup> / <sub>5</sub>	3 10 <sup>1</sup> / <sub>4</sub>	77,000
70 ft.....	74 10	7 0 <sup>1</sup> / <sub>2</sub>	13 0	4 2 <sup>1</sup> / <sub>5</sub>	4 10	97,000
80 ft.....	85 4	8 0 <sup>1</sup> / <sub>2</sub>	13 0	5 1 <sup>1</sup> / <sub>2</sub>	5 9 <sup>1</sup> / <sub>4</sub>	112,000
100 ft. thro' P. G. span.	102 9	10 0 <sup>1</sup> / <sub>2</sub>	18 0	4 2 <sup>1</sup> / <sub>8</sub>	5 0	226,000
150 ft. thro' truss span.	157 7	27 0	19 0	4 5 <sup>1</sup> / <sub>4</sub>	8 0	430,000

Dead Load. — The dead load consists of the estimated weight of the entire suspended structure. Timber assumed to weigh 4 <sup>1</sup>/<sub>2</sub> lb. per foot B. M., ballast 100 lb. per cu. foot, and rails and fastenings 150 lb. per lineal ft. of track.

(C. P. R. unit prices, 1915.)

Steel Work in Bridges:

Truss spans and steel trestles erected, per pound.....	.05 <sup>1</sup> / <sub>2</sub>
Plate girder spans erected	.05
Swing spans (truss) erected	.07
“ (plate girder) erected	.06 <sup>1</sup> / <sub>2</sub>
Credit for old steel spans removed	.01

TABLE 20. — STEEL TRETTLES.

FORMULA FOR ESTIMATING WEIGHT OF STEEL, AMOUNT OF MASONRY AND PILES FOR VARYING CONDITIONS.

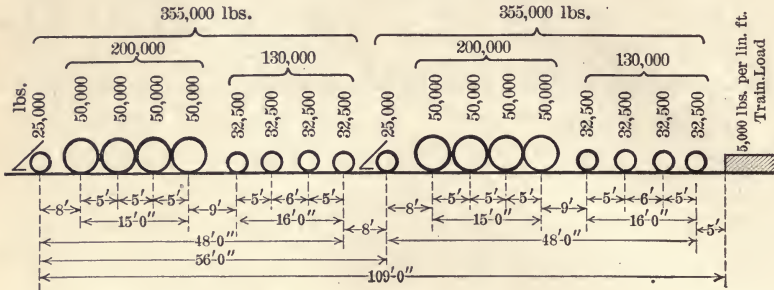

Live load (coopers E 50). Impact and wind as per specification.

STEEL TRETTLES  
UP TO 125 FEET HIGH  
WITH 60 FT. & 45 FT. SPANS

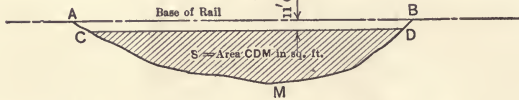

$$\begin{aligned} \text{Weight of Steelwork in Pounds} &= CD \times 925 + S \times 15.5 \\ \text{Masonry in Cubic Yards} &= CD \times 1.1 + 350 \\ \text{Number of Piles} &= .5CD + 100 \\ \text{Floor length} &= AB \end{aligned}$$

STEEL TRETTLES  
OVER 100 UP TO 150 FEET HIGH  
WITH 40 FT. & 80 FT. SPANS

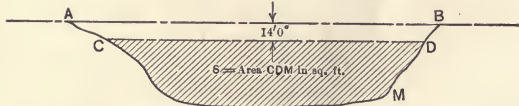

$$\begin{aligned} \text{Weight of Steelwork in Pounds} &= CD \times 1050 + S \times 17.0 \\ \text{Masonry in Cubic Yards} &= CD \times 1 + 350 \\ \text{Number of Piles} &= .5 \times CD + 100 \\ \text{Floor length} &= AB \end{aligned}$$

**Dead Load.** — The dead load shall consist of the estimated weight of the entire suspended structure. Timber shall be assumed to weigh  $4\frac{1}{2}$  lb. per foot B. M., ballast 100 lb. per cu. foot, and rails and fastenings 150 lb. per lineal ft. of track.

TABLE 21. — WOODEN TRESTLES.  
15 feet C. to C. of bents.  
FORMULA FOR ESTIMATING QUANTITIES.  
Live load (coppers E 50).

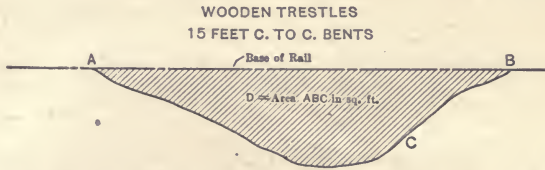

Timber in trestle including deck = 170 AB + 9.5 D feet board measure.  
 Iron " " " " = 11.3 AB + .43 D pounds.  
 Piles = { .55 AB up to 75 ft. high.  
           .66 AB above 75 ft. high.

Note. — Where piles are used deduct 150 f.b.m. per pile.

**Dead Load.** — The dead load shall consist of the estimated weight of the entire suspended structure. Timber shall be assumed to weigh  $4\frac{1}{2}$  lb. per foot B. M., ballast 100 lb. per cu. foot, and rails and fastenings 150 lb. per lineal ft. of track.

WORKING UNIT STRESSES FOR STRUCTURAL TIMBER.  
ADOPTED BY THE AMERICAN RAILWAY ENGINEERING ASSOCIATION.

The working unit stresses given in the table are intended for railroad bridges and trestles. For highway bridges and trestles, the unit stresses may be increased 25 per cent. For buildings and similar structures, in which the timber is protected from the weather and practically free from impact, the unit stresses may be increased 50 per cent. To compute the deflection of a beam under long continued loading instead of that when the load is first applied, only 50 per cent of the corresponding modulus of elasticity given in the table is to be employed.

Unit stresses in pounds per square inch.

Kind of timber.	Bending.		Shearing.				Compression.							
	Average ultimate stress.	Working stress.	Average.	Parallel to the grain.		Longitudinal shear in beams.		Perpendicular to the grain.		Parallel to the grain.		Working stresses for columns.		
				Average ultimate.	Working stress.	Average ultimate.	Working stress.	Elastic limit.	Working stress.	Average ultimate.	Working stress.	Length under $15 \times d$ .	Length over $15 \times d$ .	
Douglas fir.....	6100	1200	1,510,000	690	170	270	110	630	310	3600	1200	900	1200	(1-1/60 d)
Longleaf pine.....	6500	1300	1,610,000	720	180	300	120	520	260	3800	1300	975	1300	(1-1/60 d)
Shortleaf pine.....	5600	1100	1,480,000	710	170	330	130	340	170	3400	1100	825	1100	(1-1/60 d)
White pine.....	4400	900	1,130,000	400	100	180	70	290	150	3000	1000	750	1000	(1-1/60 d)
Spruce.....	4800	1000	1,310,000	600	150	170	70	370	180	3200	1100	825	1100	(1-1/60 d)
Norway pine.....	4200	800	1,190,000	590*	130	250	100	....	150	2600*	800	600	800	(1-1/60 d)
Tamarack.....	4600	900	1,220,000	670	170	260	100	....	220	3200*	1000	750	1000	(1-1/60 d)
Western hemlock.....	5800	1100	1,480,000	630	160	270	100	440	220	3500	1200	900	1200	(1-1/60 d)
Redwood.....	5000	900	800,000	300	80	....	....	400	150	3300	900	675	900	(1-1/60 d)
Bald cypress.....	4800	900	1,150,000	500	120	....	....	340	170	3900	1100	825	1100	(1-1/60 d)
Red cedar.....	4200	800	800,000	....	....	....	....	470	230	2800	900	675	900	(1-1/60 d)
White oak.....	5700	1100	1,150,000	840	210	270	110	920	450	3500	1300	975	1300	(1-1/60 d)

Unit stresses are for green timber and are to be used without increasing the live load stresses for impact. Values noted \* are for partially air dry timbers.

In the formulas given for columns,  $l$  = length of column, in inches, and  $d$  = least side or diameter, in inches.

TABLE 21a. — MOMENTS OF INERTIA AND SECTION MODULUS FOR WOODEN BEAMS.

VALUES OF  $I$  (MOMENT OF INERTIA) AND  $S$  (SECTION MODULUS).

Size, breadth by depth, inches.	Moment of inertia, $\frac{1}{12} bd^3$ .	Section modulus, $I \div \frac{1}{2} d$ .	Size, breadth by depth, inches.	Moment of inertia, $\frac{1}{12} bd^3$ .	Section modulus, $I \div \frac{1}{2} d$ .	Size, breadth by depth, inches.	Moment of inertia, $\frac{1}{12} bd^3$ .	Section modulus, $I \div \frac{1}{2} d$ .
2 × 2	.....	.....	5 × 9	303.75	67.50	8 × 15	2250.00	300.00
2 × 3	4.50	3.00	5 × 10	416.66	83.33	8 × 16	2730.67	341.33
2 × 4	10.66	5.33	5 × 11	554.58	100.83	8 × 17	3275.33	385.33
2 × 5	20.83	8.33	5 × 12	720.00	120.00	8 × 18	3888.00	432.00
2 × 6	36.00	12.00	5 × 13	915.41	140.83			
2 × 7	57.16	16.33	5 × 14	1143.33	163.33	9 × 9	546.75	121.50
2 × 8	85.33	21.33	5 × 15	1406.25	187.50	9 × 10	750.00	150.00
2 × 9	121.50	27.00	5 × 16	1706.66	213.33	9 × 11	998.25	181.50
2 × 10	166.66	33.33				9 × 12	1296.00	216.00
2 × 11	221.83	40.33	6 × 6	108.00	36.00	9 × 13	1647.75	253.50
2 × 12	288.00	48.00	6 × 7	171.50	49.00	9 × 14	2058.00	294.00
			6 × 8	256.00	64.00	9 × 15	2531.25	337.50
3 × 3	6.75	4.50	6 × 9	364.50	81.00	9 × 16	3072.00	384.00
3 × 4	16.00	8.00	6 × 10	500.00	100.00	9 × 17	3684.75	433.50
3 × 5	31.25	12.50	6 × 11	665.50	121.00	9 × 18	4374.00	486.00
3 × 6	54.00	18.00	6 × 12	864.00	144.00			
3 × 7	85.75	24.50	6 × 13	1098.50	169.00	10 × 10	833.33	166.66
3 × 8	128.00	32.00	6 × 14	1372.00	196.00	10 × 11	1109.17	201.67
3 × 9	182.25	40.50	6 × 15	1687.50	225.00	10 × 12	1440.00	240.00
3 × 10	250.00	50.00	6 × 16	2048.00	256.00	10 × 13	1830.83	281.67
3 × 11	332.75	60.50	6 × 17	2456.50	289.00	10 × 14	2286.66	326.67
3 × 12	432.00	72.00	6 × 18	2916.00	324.00	10 × 15	2812.50	375.00
3 × 13	549.25	84.50				10 × 16	3413.33	426.27
3 × 14	686.00	98.00	7 × 7	200.08	57.16	10 × 17	4094.17	481.67
			7 × 8	288.66	74.66	10 × 18	4860.00	540.00
4 × 4	21.33	10.66	7 × 9	425.25	94.50			
4 × 5	41.66	16.66	7 × 10	583.33	116.66	11 × 11	1220.08	221.83
4 × 6	72.00	24.00	7 × 11	776.41	141.16	11 × 12	1584.00	264.00
4 × 7	114.33	32.66	7 × 12	1008.00	168.00	11 × 13	2013.92	309.84
4 × 8	170.66	42.66	7 × 13	1281.58	197.17	11 × 14	2515.33	359.33
4 × 9	243.00	54.00	7 × 14	1600.66	228.66	11 × 15	3093.75	412.50
4 × 10	333.33	66.66	7 × 15	1968.75	262.50	11 × 16	3754.67	469.33
4 × 11	443.66	80.66	7 × 16	2389.33	298.66	11 × 17	4503.58	529.83
4 × 12	576.00	96.00	7 × 17	2865.91	337.17	11 × 18	5346.00	594.00
4 × 13	732.33	112.66	7 × 18	3402.00	378.00			
4 × 14	914.66	130.66				12 × 12	1728	288
4 × 15	1125.00	150.00	8 × 8	341.33	85.33	12 × 13	2197	388
4 × 16	1365.33	170.66	8 × 9	486.00	108.00	12 × 14	2744	392
			8 × 10	666.66	133.33	12 × 15	3375	450
5 × 5	52.08	20.83	8 × 11	887.33	161.33	12 × 16	4096	512
5 × 6	90.00	30.00	8 × 12	1152.00	192.00	12 × 17	4913	578
5 × 7	142.91	40.83	8 × 13	1464.66	225.33	12 × 18	5832	648
5 × 8	213.33	53.33	8 × 14	1829.33	261.33			



Subways.

TABLE 22. — WEIGHT OF STEELWORK AND APPROXIMATE COSTS.

The bridge portion of the subway is usually built of steel with a steel and concrete floor; or of reinforced concrete when the bridge spans are comparatively short; or a combination of steel and concrete may be developed.

WEIGHT OF STEEL IN SUBWAY STRUCTURES.

Steel girders and steel eye beam floor (2 tracks, 13 ft. c'ts). Floor beams encased in concrete.

Coopers E 50 loading.

Type.....	A.	B.	C.	D.	Conc. in floor, cu. yd.
Material.	1-span br. no bents, lb.	2-span br. center bent, lb.	3-span br. sidewalk bents, lb.	4-span br. sidewalk and center bents, lb.	
60 ft. street (area 1725 sq. ft.).					
Girders, outer.....	66,000	36,000	39,000	24,800	52
Girders, center.....	60,000	31,000	28,000	17,600	
Floor.....	54,000	54,000	54,000	54,000	
Bents.....	.....	12,000	20,000	25,500	
Total weight.....	180,000	133,000	141,000	121,900	
Weight per sq. ft. area.....	105	78	82	71	
66 ft. street (area 1900 sq. ft.).					
Girders, outer.....	76,000	48,000	50,800	29,200	57
Girders, center.....	71,000	38,000	37,600	21,200	
Floor.....	60,000	60,000	60,000	60,000	
Bents.....	.....	12,000	20,000	26,000	
Total weight.....	207,000	158,000	168,400	136,400	
Weight per sq. ft. area.....	109	84	89	72	
80 ft. street (area 2250 sq. ft.).					
Girders, outer.....	110,000	68,000	56,000	35,600	69
Girders, center.....	103,000	55,000	42,000	27,400	
Floor.....	72,000	72,000	72,000	72,000	
Bents.....	.....	13,000	20,000	27,000	
Total weight.....	285,000	208,000	190,000	162,000	
Weight per sq. ft. area.....	127	93	85	72	

COST OF VARIOUS TYPES OF SUBWAYS, STEEL GIRDEERS AND STEEL EYE BEAM AND CONCRETE FLOOR.

Two tracks, 13 ft. c'ts. Coopers E 50 loading.

Kind of bridges.	60 ft. street.		66 ft. street.		80 ft. street.	
	For two tracks.	For each addit'l track.	For two tracks.	For each addit'l track.	For two tracks.	For each addit'l track.
Type A — One span.....	\$16,400	\$6000	\$18,000	\$6700	\$21,700	\$8200
Type B — Two spans.....	15,000	5400	16,500	5800	19,200	6900
Type C — Three spans...	15,500	5500	17,100	6000	18,800	6800
Type D — Four spans...	14,900	5100	16,000	5500	17,800	6300

Cost of concrete subways.

Kind of bridge.	60 ft. street.		66 ft. street.		80 ft. street.	
	For two tracks.	For each addit'l track.	For two tracks.	For each addit'l track.	For two tracks.	For each addit'l track.
Type D — Four spans...	\$12,500	\$4200	\$13,400	\$4500	\$15,000	\$5300

For type of bridges see page 68.

## Highway Bridges.

TABLE 23.—WEIGHT OF STEEL AND APPROXIMATE COSTS.

WEIGHT OF STEEL IN STREET BRIDGES OVER THE RAILROAD WITHOUT STREET CARS.

Width of street and roadway.	Span and number of tracks.	Weight of steel, lb.	Remarks.	Type.
60 ft. st., 36 ft. r'dway	29 ft. span over 2 tracks	60,000	.....	E 2
60 ft. st., 36 ft. r'dway	42 ft. span over 3 tracks	95,000	.....	E 3
60 ft. st., 36 ft. r'dway	55 ft. span over 4 tracks	166,000	2 girders	E 4
60 ft. st., 36 ft. r'dway	55 ft. span over 4 tracks	127,000	3 girders	E 4
60 ft. st., 36 ft. r'dway	81 ft. span over 6 tracks	300,000	2 girders	E 6
60 ft. st., 36 ft. r'dway	81 ft. span over 6 tracks	240,000	3 girders	E 6

WEIGHT OF STEEL IN STREET BRIDGES OVER THE RAILROAD WITH STREET CARS.

Width of street and roadway.	Span and number of tracks.	Weight of steel, lb.	Remarks.	Type.
66 ft. st., 44 ft. r'dway	29 ft. span over 2 tracks	90,000	.....	E 2
66 ft. st., 44 ft. r'dway	42 ft. span over 3 tracks	130,000	.....	E 3
66 ft. st., 44 ft. r'dway	55 ft. span over 4 tracks	238,000	2 girders	E 4
66 ft. st., 44 ft. r'dway	55 ft. span over 4 tracks	180,000	3 girders	E 4
66 ft. st., 44 ft. r'dway	81 ft. span over 6 tracks	410,000	2 girders	E 6
66 ft. st., 44 ft. r'dway	81 ft. span over 6 tracks	324,000	3 girders	E 6

ESTIMATED COST OF STREET BRIDGES OVER THE RAILROAD. (E. N. Bainbridge.)

Description.	60 ft. street.		66 ft. street.		60 ft. street.		66 ft. street.	
	Steel.	Conc.	Steel.	Conc.	Floor depth.		Floor depth.	
	\$	\$	\$	\$	Ft., Steel.	Ft., Conc.	Ft., Steel.	Ft., Conc.
E2, single 29 ft. span over 2 tracks	12,900	11,400	15,100	13,200	3	3½	3	3½
E3, single 42 ft. span over 3 tracks	14,700	13,200	17,100	14,700	4½	5	4½	5
E4, single 55 ft. span over 4 tracks	17,800	.....	21,700	.....	4	.....	4½	.....
E4, single 55 ft. span over 4 tracks	16,400	.....	19,600	.....	3	.....	3¼	.....
E6, single 81 ft. span over 6 tracks	24,200	.....	29,800	.....	4	.....	4½	.....
E6, single 81 ft. span over 6 tracks	22,000	.....	26,500	.....	3	.....	3¼	.....
F2, three spans over 2 tracks.....	17,500	14,200	23,700	17,200	3	3½	3½	3½
F4, three spans over 4 tracks.....	20,500	17,100	27,000	20,400	3	3½	3½	3½
F6, three spans over 6 tracks.....	21,600	18,200	28,200	21,600	3	3½	3½	3½

For type of bridges E 2, E 3, etc., see page 95.

TABLE 24. — GRAVITY RETAINING WALLS.  
 QUANTITIES IN CUBIC YARDS FOR VARYING HEIGHTS.

Height of Wall in feet	Area of each course in sq. ft.	Area of each height in sq. ft.	Diagram		Cubic yards per foot run for each course	Cubic yards per foot run for each height	Height of Wall in feet		
1							1		
2							2		
3							3		
4							4		
5							5		
6							1.0000	6	
7							1.2281	7	
8	6.44	39.59					0.2385	1.4667	8
9	6.73	46.32					0.2492	1.7156	9
10	7.02	53.34					0.2600	1.9756	10
11	7.31	60.64					0.2707	2.2459	11
12	7.60	68.24					0.2814	2.5274	12
13	7.90	76.14					0.2926	2.8200	13
14	8.19	84.33					0.3033	3.1233	14
15	8.48	92.81					0.3140	3.4374	15
16	8.77	101.58					0.3247	3.7622	16
17	9.06	110.64					0.3356	4.0978	17
18	9.35	120.00					0.3463	4.4445	18
19	9.65	129.64					0.3574	4.8015	19
20	9.94	139.58					0.3681	5.1696	20
21	10.23	149.81					0.3789	5.5485	21
22	10.52	160.33					0.3896	5.9382	22
23	10.81	171.14					0.4004	6.3015	23
24	11.10	182.25					0.4112	6.7500	24
25	11.40	193.65					0.4222	7.1722	25
26	11.69	205.34					0.4330	7.6052	26
27	11.98	217.32					0.4438	8.0489	27
28	12.27	229.59					0.4545	8.5034	28
29	12.56	242.15					0.4653	8.9685	29
30	12.85	255.00					0.4761	9.4445	30
31	13.15	268.15					0.4869	9.9315	31
32	13.44	281.59					0.4978	10.4293	32
33	13.73	295.32					0.5086	10.9378	33
34	14.02	309.34					0.5193	11.4533	34
35	14.31	323.65					0.5300	11.9870	35
36	14.60	338.25					0.5407	12.5278	36
37	14.90	353.15					0.5515	13.0796	37
38	15.18	368.33					0.5622	13.6419	38
39	15.48	383.81					0.5731	14.2152	39
40	15.77	399.54					0.5841	14.7993	40

# 36 QUANTITIES IN REINFORCED RETAINING WALLS.

TABLE 25.—REINFORCED RETAINING WALLS.

**Notes:**

Earth assumed to weigh 100 lb. per cu. ft.; concrete, 150 lb.

Live load, 135 lb. per sq. ft. without impact.

Unit stresses: concrete (1-2-4), 600 lb. per sq. in. compression shear, 50 lb. per sq. in.; steel (square twisted bars or equivalent deformed section), 16,000 lb. per sq. in.

$$\frac{E_s}{E_c} = 15.$$

On clay foundation wall to be anchored against sliding.

3 in. weep pipes to be provided at distances not greater than 5 ft. apart.

At least 18 in. of broken stone backing to be provided to facilitate drainage.

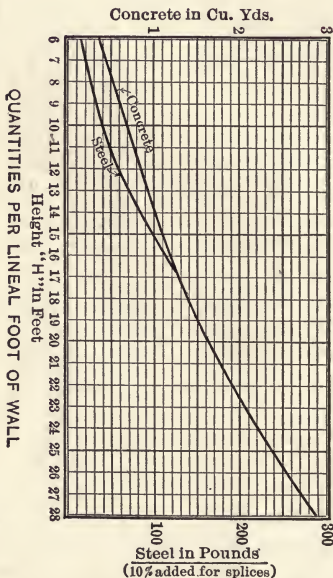
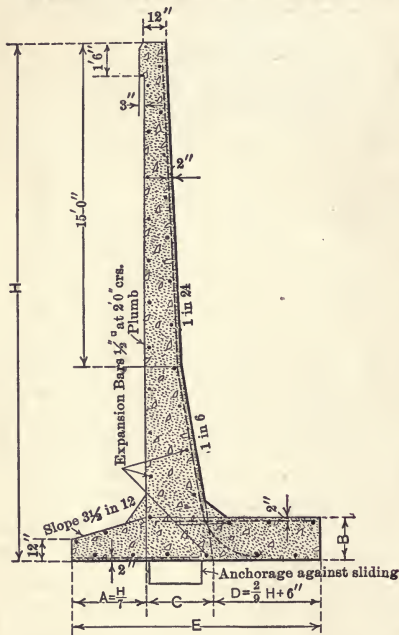

Height in feet....	8	12	16	20	24
Toe slab rein'ment. .	1/2" sq. bars: 2' 6" lg., 12" crs.	5/8" sq. bars: 3' 6" lg., 12" crs.	3/4" sq. bars: 4' 0" lg., 10" crs.	7/8" sq. bars: 5' 0" lg., 12" crs.	1" sq. bars: 5' 6" lg., 6" crs.
Heel slab rein'ment..	1/2" sq. bars: 3' 6" lg., 12" crs.	5/8" sq. bars: 4' 9" lg., 12" crs.	3/4" sq. bars: 6' 0" lg., 10" crs.	7/8" sq. bars: 7' 0" lg., 10" crs.	1" sq. bars: 8' 0" lg., 5" crs.
Vert. wall rein'ment.	5/8" sq. bars: 9' 0" lg., 12" crs.	3/4" sq. bars: 13' 0" lg., 10" crs.	1" sq. bars: 17' 0" lg., 10" crs.	1" sq. bars: 21' 0" lg., 10" crs.	1" sq. bars: 25' 0" lg., 10" crs.
				3/4" sq. bars: 7' 0" lg., 10" crs.	7/8" sq. bars: 11' 0" lg., 10" crs.
A	1' 2"	1' 9"	2' 4"	2' 11"	3' 5"
B	1' 4"	1' 6"	1' 8"	1' 10"	2' 0"
C	1' 4"	1' 6"	1' 9 1/2"	2' 5 1/2"	3' 11 1/2"
D	2' 3"	3' 2"	4' 1"	4' 11 1/2"	5' 10"
E	4' 9"	6' 5"	8' 2 1/2"	10' 4"	12' 4 1/2"
Lb. steel per ft.....	30	60	120	165	222
Cu.yd. concrete per ft.	0.51	0.85	1.20	1.65	2.22

TABLE 26. — APPROXIMATE COST OF SINGLE TRACK.  
RAIL CONCRETE CULVERTS FOR EXISTING TRACK.

Size of culvert.		Exca- vation, cu. yd.	Sup- porting track.	Con- crete, cu. yd.	Scrap rail, weight in lb.	Reinforc- ing bars, weight in lb.	Removing old structure.	Approx. total cost plus 10 per cent cont'g'es.
Width, ft.	Height, ft.							
4	2	100	\$100	17.3	2763	160	\$50 to \$100	\$467.00
4	3	100	100	22.8	2875	170	50 to 100	530.00
4	4	125	100	28.3	2987	190	50 to 100	610.00
6	2	125	100	20.8	3360	220	75 to 100	560.00
6	3	125	100	25.8	3472	240	75 to 100	620.00
6	4	150	100	31.8	3584	260	75 to 100	705.00
6	5	150	100	37.8	3696	280	75 to 100	775.00
6	6	150	100	43.8	3957	300	75 to 100	870.00
8	3	150	150	30.0	3957	280	100 to 150	770.00
8	4	150	150	36.5	4069	310	100 to 150	845.00
8	5	175	150	43.3	4181	340	100 to 150	940.00
8	6	175	150	50.0	4293	370	100 to 150	1045.00
8	7	175	150	57.6	4555	390	100 to 150	1130.00
8	8	200	150	66.0	4741	420	100 to 150	1275.00
10	4	200	150	41.2	4667	380	100 to 150	970.00
10	5	200	150	48.7	4779	410	100 to 150	1060.00
10	6	200	150	56.6	4890	450	100 to 150	1170.00
10	7	250	150	64.8	5152	480	100 to 150	1310.00
10	8	250	175	73.4	5339	510	100 to 150	1435.00
10	9	250	175	82.4	5450	550	100 to 150	1530.00
10	10	250	175	92.2	5563	580	100 to 150	1640.00

Unit prices: Concrete, \$10; scrap rail, \$18 per ton; reinforcing bars, 3¢ lb.; excavation, 75¢ cu. yd.  
For types see under culverts.

TABLE 27. — APPROXIMATE QUANTITIES.  
CONCRETE ARCH CULVERTS.

Size of arch, ft.	Concrete in barrel, cu. yd. per foot.	Concrete in two end walls, cu. yd.	Rip-rap, cu. yd.	Paving, sq. yd.	Formulae for length f. to f. H = top of invert to bottom of rail.	Remarks.	
						Ft. In.	Ft. In.
4	0.5	13.25	2.0	8.0	3H + 8 0	-5 0	} for length of barrel
5	0.8	20.00	4.3	13.0	3H + 5 3	-5 5	
6	1.0	29.00	6.1	18.3	3H + 2 9	-5 4	
7	1.25	41.00	8.0	24.0	3H + 0 3	-6 3	
8	1.5	57.2	12.0	33.0	3H - 2 9	-6 9	
10	2.18	84.0	17.3	52.0	3H - 8 0	-7 7½	
12	2.9	126.0	24 15	72.0	3H - 12 6	-8 6	
14	3.9	180.0	33.5	100.5	3H - 18 0	-9 11	

For types see under culverts.

TABLE 28.—LIST OF BORING TOOLS FOR DISTRICT ENGINEER'S OFFICE.

Description.	Approximate Cost.
1 set of shear legs, each leg 15' 0" long × 4' 3" painted at the foot. Preferably of elm. Connected at top with 1 in. diameter mild steel bolt bent to allow legs to spread. . . . .	\$4.50
1-in. diameter mild steel shackle suspended from above described bolt. . . . .	0.75
16 fathoms of Manilla rope at about 1.5 lb. per fathom. . . . .	2.15
1 set of double blocks to take same. . . . .	5.00
30 foot of 2-in. bore W. I. pipe in 6-ft. lengths with connections complete. . . . .	4.50
1 3-ft. length of same pipe. . . . .	0.45
<i>(Note. — Preferably these pipes should be thick enough to enable a male and female screw joint to be made so that outside diameter of connected pipes may be same throughout length.)</i>	
1 steel cutting edge to screw onto end of pipe. Edge to be beveled from the inside outwards. . . . .	1.00
1 collar to fit on top of pipe for driving and lifting same. (Sketch.)	1.25

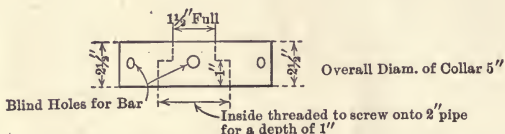

2 maple levers 6 ft. 0 in. long for getting up pipes. (Sketch.) . . . . . 2.00

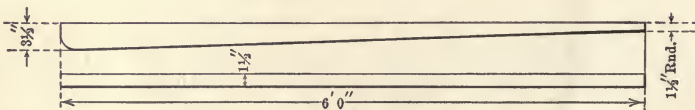

6 hard wood blocks each 1' 0" × 6" × 3" . . . . . 1.00

1 100-lb. weight monkey for driving pipes, with eye bolt in top and guiding shaft in bottom. (See sketch.) . . . . . 15.00

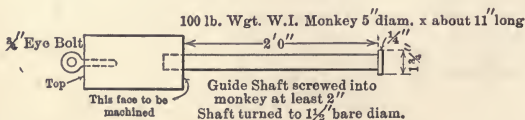

1 light sling chain about 6 ft. 0 in. long. . . . .	\$ 3.50
2 pairs of pipe tongs for above pipes. (Brock's Patent preferred.) .	8.00
40 ft. of $\frac{7}{8}$ -in. square W. I. rods with steel connections at ends as per sketch. . . . .	14.00

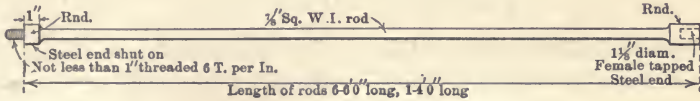

2 spanners to fit square rods. (Sketch.) . . . . .	2.25
--	------

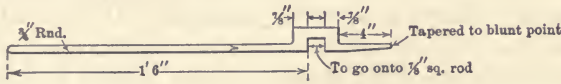

1 pair handles for turning rods. (Sketch.) . . . . .	8.00
--	------

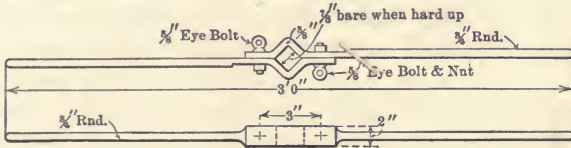

1 mild steel auger, maximum diameter $1\frac{1}{4}$ in. with hardened point and connection to fit onto rods. . . . .	5.00
2 steel drills to fit onto rods. Chisel pointed, 6 ft. long, width of cutting edge $1\frac{1}{4}$ in. . . . .	7.00
1 sand pump. Outside diameter $1\frac{1}{2}$ in., with connection to fit onto rods. Fitted with clack valve and seat and opening at top end to allow of cleaning out. . . . .	2.50
1 8-lb. sledge hammer double faced. . . . .	2.00
1 hand hammer. . . . .	0.75
1 maul. . . . .	1.00
1 adjustable spanner. . . . .	1.25
1 shovel (long handle, round point). . . . .	1.50
1 oil can and feeder. . . . .	0.50
1 triangular bastard 9-in. file (for cleaning threads, etc.). . . . .	0.65
2 cold chisels. . . . .	0.60
1 tool box. Inside dimensions 6' 6" x 9" wide x 1' 0" deep, complete with lock. . . . .	4.00
Sundries, such as cotton waste, planks, etc. . . . .	4.00

Total. . . . . \$105.00

## CHAPTER III.

## COST OF RAILROADS.

**Cost of Railroads per Mile.** — To arrive at an approximate cost of a line of railroad already built or to be built, by taking a sum per mile from a record of the actual cost of other lines built in the same territory and to the same standards, may serve very well for discussion or as a means of giving an idea of the amount likely to be involved, but it is no criterion that it will be even approximately correct in the final analysis.

To show how varied are the costs per mile even in the same state or province, the statements shown in Tables 29 and 30 may be compared, from which it will be noted that out of twenty-one items and a dozen different lines, hardly two figures are comparable. There are many reasons for this but the principal one is due to the fact that the contours and physical conditions in no two cases are alike even when the lines are built side by side.

In view of this, when estimating the cost of a new line even very approximately, it would be exceedingly risky to base it on a cost per mile from any records without going over the plans and profiles and taking out the quantities and ascertaining prices for labor and material in the territory in which the line is to be built.

\* **Cost of the Alaska Central Railroad, 54 Miles.** — The Alaska Central runs from Seward, a deep water port on Resurrection bay, which is about in the center of the south coast of Alaska, north toward Fairbanks, on the Tanana river. The road is standard gage, laid with 65 lb. rails. The maximum grade is 1 per cent, except over two mountain ranges, where it is 2.2 per cent. The maximum curvature is 14 degs. The cuts and fills are heavy and there are seven tunnels and many trestle bridges.

The cost of 54 miles of road was \$3,230,000. This includes cost of organization, but not cost of rolling stock, station buildings, docks, office fixtures, etc. The cost of separate sections, starting from the terminus at Seward, was as follows:

7	miles at \$20,000 . . . .	\$140,000	2	miles at 50,000 . . . .	100,000
9	“ “ 40,000 . . . .	360,000	4	“ “ 100,000 . . . .	400,000
18	“ “ 55,000 . . . .	990,000	3	“ tunnels . . . . .	300,000
7	“ “ 35,000 . . . .	245,000	1	“ approaches . . . .	295,000
5	“ “ 80,000 . . . .	400,000			



The cost per mile of the above 54 miles was \$60,000. Deducting the  $2\frac{1}{3}$  miles of tunnels and approaches, the cost per mile of 52 miles was \$51,000. The  $\frac{2}{3}$  of a mile of tunnels cost at the rate of \$450,000 a mile, and  $1\frac{2}{3}$  miles of approaches, \$177,000 a mile.

\* Cost of Cheboygan Extension D. & M. Ry., 23.46 Miles. — The Cheboygan extension of the Detroit & Mackinac was opened in 1904. It runs from Tower, Mich., northwest to Cheboygan, 23.46 miles.

The first four miles of road from Tower is across an open plain. The next 12 or 14 miles, to the northern end of Mullet lake, is through slightly hilly, well-wooded country, with short stretches of burnt ground and swamp. The rest of the route is in rolling country, most of which is cleared land.

The road is single-track, laid with 70 lb. rail, maximum curvature 1 degree and maximum grade 0.5 per cent. Good gravel ballast was found about one mile from grade. There was no rock work and the bridge and culvert work was light. The largest bridge is a steel structure, 130 ft. span, with concrete abutments, over the Cheboygan river. The rest of the work is concrete.

The cost of the 23.46 miles was \$323,526, including engineering, grading, clearing, grubbing, ties, rails, ballast, bridges, trestles, culverts, track fastenings, frogs, switches, track laying and surfacing, fencing portions of right-of-way, crossings, cattle guards, signs and other expenses. This is \$13,790 per mile. The cost of station buildings, roundhouse, telegraph lines, interlockers and signal operators was \$18,724, or \$800 per mile.

The railroad lines in the States of Minnesota, Wisconsin and Michigan have been valued by a Commission and the figures are given below on a cost per mile basis, including the original cost of the Gt. N. Ry. by W. L. Webb.

The valuation figures were made both from a standpoint of cost of reproduction and also their present value as affected by depreciation. The unit figures given, however, have, in some cases, been combined and interpolated so as to make them conform with the present I. C. C. Classification and for this reason a number of the items may be inaccurate. However, they are near enough for general comparisons.

\* Railroad Age Gazette, Aug. 21st and Sept. 25, 1908.

TABLE 29.—AVERAGE COST PER MILE OF STEAM RAILROADS.

No.	Items.	State of			
		Minne- sota, 1907. Valuation.	Wiscon- sin, 1903. Valuation.	Michigan, 1900. Valuation.	*Washington, Gt. N. Ry. 488 miles. Original cost.
1	Engineering; etc.....	\$8,066	\$3,552	\$4,153	\$3,463
2	Land.....	9,637	3,719	3,665	4,286
3	Grading.....	7,372	} 5,098	2,778	12,441
4	Protect work, rip-rap, retaining walls.....	318			
5	Tunnels and subways.....	33	122	147	7,280
6	Bridges, trestles and culverts...	2,576	2,372	1,027	4,318
7	Elevated structures.....	.....	.....	.....	.....
8	Ties.....	2,303	1,529	1,426	1,198
9	Rails.....	4,348	3,773	3,674	5,932
10	Other track material.....	992	980	680	943
11	Ballast.....	1,239	788	476	.....
12	Track laying and surfacing.....	703	447	839	593
13	Right of way fences, cattle guards and signs.....	364	277	431	256
14	Snow and sand fences and snow shed.....	.....	.....	.....	.....
15	Crossings and signs (see 13)....	.....	.....	.....	.....
16	Station and office buildings.....	771	476	526	.....
17	Roadway buildings.....	690	353	158	113
18	Water stations.....	211	161	93	} 258
19	Fuel stations.....	95	54	39	
20	Shops and engine houses.....	1,157	610	418	1,039
21	Grain elevators.....	.....	} 163	204	.....
22	Storage warehouses.....	.....			
23	Wharves and docks.....	799	260	707	166
24	Coal and ore wharves.....	.....	.....	.....	.....
25	Gas, steam and power plants...	105	9	13	.....
26	Telephone and telegraph lines...	185	19	33	47
27	Signals and interlockers.....	73	52	64	.....
	Miscellaneous.....	2,710	427	188	991
	Total cost per mile without equipment.....	\$44,707	\$25,241	\$21,739	\$44,412
	<i>Equipment:</i>				
	Locomotives.....	2,249	1,342	1,155	.....
	Passenger equipment.....	871	627	408	.....
	Freight car equipment.....	6,176	3,630	2,527	.....
	Miscellaneous equipment.....	175	70	89	.....
	Marine equipment.....	6	0	220	.....
	Total average cost per mile including equipment.....	\$54,184	\$30,910	\$26,138	.....

\* The high cost of grading tunnels and bridges is due to the mountainous character of the country. One tunnel 13,813 feet long cost about \$184 per foot or a total of \$2,524,212.

TABLE 30. — AVERAGE COST PER MILE OF STEAM RAILROADS.

State or Province.....	Ontario.				Mani- toba.	Saskatchewan.	
	182 M.	16.3 M.	17.7 M.	57.9 M.		25 M.	15 M.
Miles built.....	Y.	X.	W.		V.	T.	S.
Name of railway.....	1912-14.	1912-13.	1910-11.	1911-12.	1914.	1914.	1914.
Date built.....	Items.						
Engineering.....	\$2,765	\$1,822	\$607	\$1,312	\$477	\$623	\$801
R. of way and stn. grounds.....	8,188	5,979	3,234	3,817	470	523	279
Grading.....	23,231	22,795	6,883	13,953	2,390	3,563	6,994
Bridges, trestles and culverts.....	13,560	5,673	8,326	5,102	263	1,366	1,792
Ties.....	3,371	1,896	1,718	2,034	3,205	3,062	4,187
Rails.....	6,275	4,677	5,214	4,521	2,010	2,258	4,931
Frogs and switches.....	268	98	275	136	55	62	94
Track fastenings.....	1,532	1,352	1,367	1,439	1,537	1,219	1,613
Ballasting, t. laying and surfacing.....	4,007	2,344	3,106	2,653	2,459	1,831	4,534
Fences.....	738	771	618	669	394	471	471
Crossings and signs.....	81	73	55	57	24	8	24
Interlocking and signals.....	379	.....	887	264	.....	.....	.....
Telegraph lines.....	669	873	404	409	288	232	327
Station buildings and frt. sheds.....	1,875	657	1,401	420	25	28	315
Shops, engine houses and tools.....	597	.....	.....	.....	.....	.....	453
Water stations.....	1,119	.....	419	472	50	17	588
Fuel stations.....	86	.....	.....	.....	.....	.....	108
Misc. structures.....	710	265	426	183	4	272	662
Operating expenses.....	.....	.....	.....	.....	.....	.....	621
Injuries.....	5	.....	.....	3	.....	.....	.....
Other expenses.....	44	25	60	36	49	65	106
Total cost per mile.....	\$69,500	\$49,300	\$35,000	\$37,500	\$13,700	\$15,600	\$28,900
Bridge loading.....	210%	210%	210%	210%	180%	210%	210%
Ruling grade.....	0.4%	1%	0.4%	0.4%	0.3%	1%	0.4%
Max. curve.....	4°	10°	3°	10°	2°	4°	5°
Weight of rail.....	85 lb.	85 lb.	85 lb.	85 lb.	56 lb.	65 lb.	65 lb.
Classification by traffic.....	A	A	A	A	C	B	B

State or Province.....	Sask. & Alta.	Alberta.			British Col.
	195 M.	25 M.	75 M.	27 M.	100 M.
Miles built.....	R.	P.	O.	N.	M.
Name of railway.....	1914.	1914.	1914.	1914.	1914.
Date built.....	Items.				
Engineering.....	\$1,023	\$1,210	\$583	\$755	\$1,430
R. of way and stn. grounds.....	312	127	234	511	810
Grading.....	11,956	19,419	5,807	4,399	17,939
Bridges, trestles and culverts.....	3,875	2,266	945	194	1,673
Ties.....	2,152	1,081	1,888	645	1,373
Rails.....	5,532	2,763	4,346	2,854	4,205
Frogs and switches.....	142	108	20	77	64
Track fastenings.....	1,176	642	902	791	990
Ballasting, t. laying and surfacing.....	3,541	1,141	1,915	2,583	3,090
Fences.....	446	294	350	410	496
Crossings and signs.....	51	132	35	39	16
Interlocking and signals.....	.....	.....	.....	.....	.....
Telegraph lines.....	423	181	240	385	345
Station buildings and frt. sheds.....	207	5	9	4	141
Shops, engine houses and tools.....	268	.....	14	.....	.....
Water stations.....	676	6	135	301	90
Fuel stations.....	65	477	.....	.....	.....
Misc. structures.....	562	.....	520	331	108
Operating expenses.....	Cr. 92	Cr. 4	Cr. 12	Cr. 180	.....
Injuries.....	.....	.....	.....	.....	.....
Other expenses.....	85	52	59	1	30
Total cost per mile.....	\$32,400	\$29,900	\$18,000	\$14,100	\$32,800
Bridge loading.....	210%	180%	180%	210%	210%
Ruling grade.....	0.4%	0.8%	0.4%	0.4%	0.4%
Max. curve.....	4°	5°	6°	4°	10°
Weight of rail.....	80-85 lb.	80 lb.	56 lb.	56-85 lb.	65 lb.
Classification by traffic.....	B	B	C	B-C	B

In the statement, Table 30, the lines may be classified somewhat as follows:

A. First class main line for heavy traffic permanent structures and heavy rail throughout all tie plated.

B. First class branch line with main line structures, medium weight rail for medium traffic likely to increase to main line traffic in the future.

C. Second class branch line, light rail for light traffic, not likely to increase to any great extent.

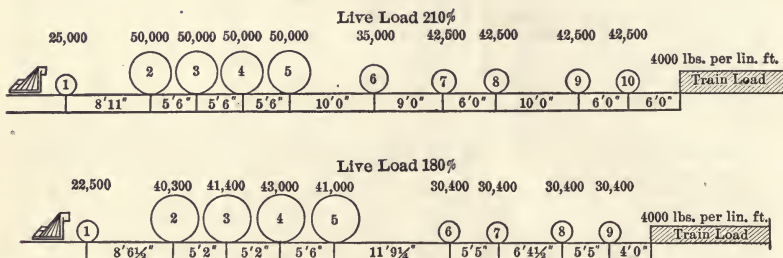

Bridge Loading assumed in Table 30.

### A. R. E. A. Classification of Railways.

Class "A" includes all districts of a railway having more than one main track, or those districts of a railway having a single main track with a traffic that equals or exceeds the following:

Freight car mileage passing over district per year per mile, 150,000; or, Passenger car mileage per year per mile of district, 10,000; with maximum speed of passenger trains of 50 miles per hour.

Class "B" includes all districts of a railway having a single main track, with a traffic that is less than the minimum prescribed for Class "A," and that equals or exceeds the following:

Freight car mileage passing over district per year per mile, 50,000; or Passenger car mileage per year per mile of district, 5,000; with maximum speed of passenger trains of 40 miles per hour.

Class "C" includes all districts of a railway not meeting the traffic requirements of Classes "A" or "B."

**Unit Prices.** — The foregoing remarks on the cost of railroads may also apply to unit prices for construction work but to a lesser degree as they are more amenable to the judgment of the engineer who uses them. The extent to which such figures may be used will depend entirely on the knowledge possessed of the character of work in hand and the experience of the estimator.

The classification and the quantities involved in grading are very important as they are subject to greater variation than the structures or other materials; for example on a short stretch of the Alaska Railway from Mile 35 to 38 the grading varied from  $38\frac{1}{2}$  cents to \$1.06 per cubic yard, somewhat as follows:

Mile 35 rock fill from borrow, average haul 700 ft.; 4544 cu. yd., cost per yd.....	1.06
Mile 36 earth fill in swamp, from borrow, haul 3522 ft.; 4488 cu. yd., cost per yd.....	0.38 $\frac{1}{2}$
Mile 38 earth fill in swamp, from borrow, haul 4133 ft.; 5283 cu. yd., cost per yd.....	0.46 $\frac{1}{4}$

On the above work no steam shovels were used, all excavation being done by hand labor. On Mile 35 the rock (a hard slate) a  $3\frac{1}{8}$  in. steam drill, supplied with steam by a 10 H. P. boiler, was used and material hauled in 1 cu. yd. cars. On Mile 36 and 38 the haul was made in 10 car lots, hauled by two horses.

In addition to the units given in Table 31 there are also a number of other items, such as right-of-way, station grounds, interlocking, signals, telegraph lines, etc., which have to be considered; there are also the items of supervision, engineering, etc., usually covered by a percentage of the total cost which ranges from 10 to 15 per cent on an average as follows:

Engineering and supervision.....	3.0 to 4.0 per cent
Interest during construction.....	2.0 to 3.25 per cent
Taxes during construction.....	0.10 to 0.25 per cent
Insurance.....	0.25 to 0.5 per cent
Organization and legal expenses.....	2.50 to 3.5 per cent
Contingencies.....	2.25 to 3.5 per cent
Total.....	10 to 15 per cent

The following unit prices, Table 31, are contract figures for 183 miles of line, built 1912-1914, and may serve to give an idea of unit costs and the various items that have to be considered in construction work.

TABLE 31.—RAILWAY CONSTRUCTION UNIT PRICES.

Clearing.....	\$40.00 per acre	24" C. P. in place..	\$2.80 per L. ft.
Grubbing.....	40.00 per square	30" " " " ..	3.50 " "
Solid rock.....	1.35 per c. y.	Lay 24" tri. pipe...	1.30 " "
" " borrow...	1.20 " "	" 30" " " ..	1.50 " "
Loose rock.....	0.48 " "	Dry exc. foundation	1.00 " C. yd.
Hardpan.....	0.37 " "	Wet " " "	2.00 " "
Earth.....	0.23 " "	Solid rock " "	5.00 " "
Overhaul 500-2800'	0.01 " "	Rip-rap.....	3.00 " "
Haul over 2800'-4 m.	0.23 " "	Paving.....	3.00 " "
Trainfill, etc.....	0.35 " "	Steel in bridges, \$2.50 to \$3.75 per 100 lb.	
" trestles...	0.25 " "	" erected \$1.20 to \$1.85 per 100 lb.	
" " special	0.30 " "	Sheet piling.....	30.00 " M. F. B. M.
Concrete, bridges...	9.00 " "	Fencing.....	\$347.50 per mile of fence
" culverts..	10.00 " "	Post holes in rock..	1.50 each
" reinforced	11.00 " "	Gates.....	6.00 "
" ret. walls.	8.00 " "	Protection fences...	46.85 per track mile
Rubble masonry...	6.00 " "	Cattle guards.....	19.35 " " "
Dry " ..	4.00 " "	Signs.....	69.50 " " "
Masonry in bridges	16.00 " "	Bridge ties, del....	28.00 " M. F. B. M.
Timber, trestles...	45.00 " M. F. B. M.	Switch ties " ....	32.00 " " "
" " temp.	35.00 " "	Track " .....	0.84 each del.
" culverts...	35.00 " "	Track laying.....	774.00 per track mile
Iron, bridges & culverts.....	0.06 " lb.	Placing switches...	50.00 each
Piling.....	0.43 " L. ft.	" diamonds...	50.00 "
Lay 12 to 18" C. I. pipe.....	0.25 " "	Ballast .....	0.53 per yd.
Lay 24 to 30" C. I. pipe.....	0.40 " "	" & surfac.....	2185.00 " mile
12" C. P. in place..	1.00 " "	Crossing plank....	25.00 " M. F. B. M.
18" " " " ..	1.75 " "	Peeling ties.....	0.03 each
		Force account work.	Current rates for labor and material plus 10 per cent.
		Train service.....	5.00 per hour

### The A. R. E. A. Width of Roadway at Subgrade:

(1) Class "A" Railways, with constant and heavy traffic, should have a minimum permanent width of twenty (20) feet at subgrade.

(2) In the theory upon which the width of embankment at subgrade is based, it is considered that the track, in excavations, is placed upon what is virtually a low embankment; and in order to preserve uniformity of conditions immediately under the track throughout the line, the width of subgrade in excavations should be made the same as on embankments, outside of which sufficient room should be allowed for side ditches.

The tops of embankments and bottoms of cuttings ready to receive the ballast is termed the subgrade.

The slopes of embankments and excavations shall be of the following inclinations, as expressed in the ratio of the horizontal distance to the vertical rise:

Embankments, Earth—One and one-half to one; Rock—From one to one, to one and one-half to one; Excavations, Earth—One and one-half to one; Loose Rock—One-half to one; Solid Rock—One-quarter to one.

These ratios may be varied according to circumstances, and the slopes shall be made as directed in each particular case.

The following gives in brief the work entailed, and as covered by the foregoing unit prices.

**Clearing.** — Under this head is included the clearing of the right of way of all trees, logs, brush and other perishable matter, all of which is usually burnt or otherwise disposed of, unless specially reserved to be made into ties, timber or cordwood.

Clearing is paid for by the acre where actually performed, and dangerous trees, cut outside the right of way, at a specified rate per single tree.

On ground to be covered by embankments more than two feet high, all trees and stumps are cut off even with the surface of the ground and removed; the price paid for clearing covers close cutting.

**Grubbing.** — In all excavations including borrow pits, on all ground to be covered by embankments less than two feet high, and from all ditches, drains, new channels for water ways, and other places, when required, all stumps and large roots are grubbed out and removed.

Grubbing is estimated and paid for by the units of 100 feet square (10,000 square feet) when actually performed, where excavation is less than four feet deep, and where embankment is less than two feet high. Where excavations are over four feet deep, the cost of grubbing is included in the price of grading.

**Grading.** — Under this head is included excavations and embankments for the formation of the roadbed, all road crossings, all diversions of roads and streams, all borrow pits and ditches, foundation pits for bridges, trestles, culverts, buildings and structures, and all similar works connected with and incident to the construction of the roadbed.

Grading is classified under the following heads, "Solid Rock," "Loose Rock," "Hard Pan," and "Earth."

"Solid Rock" includes rock in solid beds or masses in its original position, which cannot be removed without blasting, and boulders or detached rock measuring one cubic yard or over.

"Loose Rock" includes all detached rock or boulders measuring more than one cubic foot and less than one cubic yard, and all shale, slate, soap stone, disintegrated granite, and other soft rocks, which can be removed without blasting, though blasting may be occasionally resorted to.

“Hard pan” includes cemented gravel, hard pan, indurated clay or combinations of the same whose hardness is such that if in a suitable location could not be plowed by an average four horse team.

“Earth” includes all other material such as Loam, Clay, Sand, Quicksand, Gravel, Muskeg, Angular Rock Fragments, and small boulders.

Material borrowed for embankment is not classified higher than loose rock, without prior written authority.

Measurements will usually be made in excavation. In prairie or level country, where the embankments largely exceed the excavations, measurements will be made in embankments.

**Haul.** — The limit of free haul is 500 feet and the limit to which any material may be required to be hauled will be 2500 feet. For any haul exceeding 500 feet the Contractor shall be paid at the specified price per cubic yard per station.

**Cross Waying.** — When required, in swamps or muskegs, cross ways shall be put in, built of logs as long as the full width of the embankment and not less than 6 inches in diameter. No ditches shall be made in either side of cross ways. Cross waying shall be paid for at the specified rate per square of 100 square feet, one foot deep.

**Buildings, etc.** — The price paid for buildings, water tanks, turntables, depots, section houses, and other standard structures, will be held to include the foundations. The specifications for concrete, rubble masonry, etc., and the prices which govern such work, are intended to cover additional work of the same character which may be required and is not shown on the plans.

**Piling.** — Piling will be paid for under the following heads:

“Piling in Structure” to include that portion of the pile furnished and driven by the Contractor, and left in the finished structure, and price for same will include all work of any kind in connection therewith.

“Piling cut off” will include that portion of the pile furnished by the Contractor, but cut off before or after the pile has been driven, but any lengths in excess of those ordered by the Engineer shall not be paid for.

“Pile driving” will include piles furnished by the Company and driven by the Contractor, only that portion of the pile left



in structure will be paid for. The price will include all work of any kind in connection therewith.

Rings shall not be paid for, but shoes will be paid for at the specified rate per shoe.

**Culvert Pipe.** — Culvert pipe will be supplied by the Railway Company, delivered on board cars at the nearest railway station. The Contractor will be paid for hauling the pipe to the site at the specified rate per ton mile, and for placing it in position at the specified rate per lineal foot, which shall include the cost of all labor and material necessary and incidental to the completed work.

**Tile Drains.** — The trenches for tile drains must be excavated below frost line and to a true grade. The tiles shall be laid with ends butted and shall be covered with grass, hay or straw, over which shall be laid fine gravel to a depth of 4 inches, and the balance of the trench filled with gravel, broken stone or other material.

**Tracklaying.** — Tracklaying will include all work of loading, unloading, and handling material; laying the main track, spurs, turn-outs, wyes, and other permanent tracks; frogs, switches, rail braces, tie plates, crossings, etc.; laying and spiking plank of road crossings, setting all track markers or signs, and such necessary cutting down or filling up the inequalities of the roadbed as will allow of the passage of trains, without damage to rail or rolling stock, until the proper surfacing and ballasting is performed.

The Railway Company to furnish the Contractor with the rails, track fastenings, switches, and ties on board cars at the point where the work under construction joins the already constructed line of the Company. This point is usually specified in contract.

“Surfacing ‘A’” will include all work of procuring surfacing material from side ditches or other places where allowed, putting under the track, surfacing, lining and all other work incident to the preparation of the track for operation, where material for surfacing is obtained from the side.

“Surfacing ‘B’” will include the cost of all train hauled material under the track, surfacing, lining and all other work incident to the preparation of the track for operation where surfacing is done with train hauled material.

Ballasting will include the loading, hauling, unloading alongside of track, and transportation of all material hauled by train for the purpose of surfacing the track.

**Cost of Train Service.** — The cost of train service on construction work will depend upon the amount of work involved, the kind of equipment necessary and the time such equipment is likely to be required.

Table No. 32 gives the daily rental charge that may be considered a fair average for the value and class of equipment given, and the estimated working days covered per annum.

When the cost of the equipment is higher than that shown, the rental can be obtained by adding the same percentage to the rental as to the equipment. For example, if a locomotive cost \$22,000 instead of \$20,000 as given, this is an advance of 10 per cent so that the rental would also be advanced 10 per cent making it \$17.60 instead of \$16.00 per day.

On the C. L. O. & W. Ry. the cost of train service allowed the Contractor was at the rate of \$5.00 per hour, including engine and train crews. This figure was arrived at as follows:

A day was considered to represent a run of 150 miles.

Items.	Per day.	Per mile.
Rental of locomotive.....	\$16.00	\$0.1066
Rental of van.....	0.75	0.0050
Oil waste, etc.....	2.45	0.0164
<i>Wages:</i>		
Engineer.....	6.75	0.0451
Fireman.....	4.45	0.0297
Conductor.....	5.45	0.0363
Brakemen (2).....	7.25	0.0484
Fuel, estimated.....	31.90	0.2125
Total.....	\$75.00	\$0.50
Average 10 miles per hour = \$5.00 per hour.		

Specifications, proposals and contract forms applicable to railway construction work are issued in printed form by the A. R. E. Assoc. and the various items are covered in accordance with the best standard practice.

TABLE 32.—RATES FOR RENTAL OF EQUIPMENT. 1914.

THE FOLLOWING PRICES ARE FAIR AVERAGE FIGURES OF RENTAL RATES FOR THE USE OF EQUIPMENT, SUCH AS STEAM SHOVELS, LIDGERWOODS, ENGINES, HART CARS, FLATS, ETC., WHEN USED FOR BALLASTING, BRIDGE FILLING, BETTERMENT OR CONSTRUCTION WORK.

Class of equipment.	Approximate value.	Interest and depreciation.	Annual charge.	Average work days per annum.	Daily rental.	Shop repairs, daily charge.	Field repairs, daily charge.	Total rental daily charge.
Steam shovels, 50 ton or over.....	\$13,000.00	%	\$2600.00	200	\$13.00	\$3.00	\$2.00	\$18.00
Steam shovels, under 50 tons.....	10,000.00	20	2000.00	200	10.00	2.00	2.00	14.00
Standard locomotives.....	20,000.00	12	2400.00	300	8.00	4.00	4.00	16.00
Dinkey locomotives.....	5,000.00	20	1000.00	200	5.00	1.00	1.00	7.00
Lidgerwood unloaders.....	6,000.00	20	1200.00	200	6.00	1.00	1.00	8.00
Ballast plows.....	1,000.00	20	200.00	200	1.00	....	....	1.00
Jordan spreaders.....	6,500.00	20	1300.00	200	6.50	1.00	0.50	8.00
Rodger ballast spreaders.....	1,200.00	20	240.00	100	2.40	0.30	0.30	3.00
Hart cars, 50-ton.....	1,550.00	15	232.50	200	1.17	0.23	0.10	1.50
Hart cars, 40-ton.....	1,000.00	20	200.00	200	1.00	0.25	0.25	1.50
Side dump cars, 50-ton.....	1,350.00	15	202.50	200	1.02	0.25	0.13	1.40
Flat cars.....	900.00	15	135.00	300	0.45	0.10	0.10	0.65
Air dump cars, 12-yard.....	1,430.00	15	214.50	200	1.08	0.10	0.07	1.25
Air dump cars, 20-yard.....	2,275.00	15	341.05	200	1.71	0.14	0.10	1.95
Air dump cars, 30-yard.....	2,990.00	15	448.50	200	2.25	0.15	0.10	2.50
Boarding cars.....	400.00	15	60.00	200	0.30	0.10	0.10	0.50
Vans.....	1,225.00	12	147.00	300	0.49	0.16	0.10	0.75
Box cars.....	1,000.00	12	120.00	300	0.40	0.10	....	0.50
Coal cars.....	1,400.00	15	210.00	300	0.70	0.10	....	0.80
Track pile drivers, wooden.....	7,000.00	12	840.00	100	8.40	1.00	1.60	11.00
Tracklaying machines.....	5,000.00	12	600.00	100	6.00	2.00	1.00	9.00
Track derricks, self propelling.....	3,000.00	12	360.00	100	3.60	1.00	0.40	5.00
Iron cars.....	50.00	20	10.00	100	0.10	0.03	....	0.13
Push cars.....	30.00	20	6.00	150	0.04	0.02	....	0.06
Hand cars.....	40.00	25	10.00	200	0.05	0.02	....	0.07
Track velocipedes.....	40.00	30	12.00	200	0.06	0.04	....	0.10
Motor cars.....	300.00	25	75.00	200	0.38	0.12	....	0.50
Dump cars, 6-yard.....	350.00	20	70.00	200	0.35	0.10	0.05	0.50
Dump cars, 4-yard.....	250.00	20	50.00	200	0.25	0.05	0.05	0.35
Dump cars, 1½-yard.....	90.00	20	18.00	200	0.09	0.05	0.06	0.20
Rail per ton.....	30.00	10	3.00	200	0.015	....	0.005	0.02
Wagons.....	160.00	30	48.00	150	0.32	0.08	....	0.40
Carts.....	45.00	30	13.50	150	0.09	0.06	....	0.15
Wheel scrapers.....	60.00	30	18.00	150	0.12	0.13	....	0.25
Slush scrapers.....	8.00	40	3.20	150	0.02	0.03	....	0.05
Plows, grading.....	25.00	30	7.50	150	0.05	0.05	....	0.10
Steam drills.....	230.00	20	46.00	100	0.46	0.14	....	0.60
Boilers up to 10 H.P.....	300.00	15	45.00	100	0.45	0.30	....	0.75
Steam pumps up to 10 H.P.....	300.00	15	45.00	100	0.45	0.30	....	0.75
Hoisting engines up to 10 H.P.....	600.00	15	90.00	100	0.90	0.60	....	1.50
Horse pile drivers.....	800.00	20	160.00	100	1.60	....	0.15	1.75
Steam pile drivers, complete.....	2,000.00	15	300.00	100	3.00	0.50	0.50	4.00

## CHAPTER IV.

## GRADE SEPARATION.

Where street and railway cross each other on the level, and make what is known as a grade or level crossing, the separating of such crossings when necessary involves either the raising of the tracks above the street level or "track elevation," or the lowering of the tracks below the street level or "track depression," or a combination of both may be developed. In the working out of such schemes a great many factors have to be considered and each case is usually a study by itself.

In general it may be said that track elevation is the most common of all schemes. Undoubtedly the railways would save a great deal by anticipating and making provision for grade separation even when it seems remote rather than have it forced upon them at some future date when the scheme is likely to be a much more ambitious and costly one.

The benefits accruing from grade separation can very seldom be expressed in dollars and cents, and is adopted usually when other means of protection such as crossing gates, watchmen, visible and audible signals, limiting speed of trains, etc., have proved inadequate, and whilst it is a means of increasing the safety and facility of railway operation as well as the convenience and safety of highway and street traffic, it is generally measured by the amount of traffic and hazard rather than from a purely economic standpoint.

Some of the benefits said to be common to each scheme are briefly:

Reduction in grade crossing fatalities.

Gain of time in train operation, street railway and general street traffic.

New districts are more easily accessible, thus reducing local congestion in population.

Accessibility to churches, markets and schools improved.

Reduction of fire losses as the fire departments are not delayed by closed gates, etc.

Elimination of damage suits, watchmen's gates, etc.

Some of the objections to track elevation are briefly:

Work must begin from below and go up and traffic has to be handled without delay at the same time.

In congested districts the work usually has to be divided into a number of different sections.

It is cheaper to carry the street traffic over the railway than the railway traffic over the streets.

These restrictions increase the cost of the work, complicate the handling of trains and street traffic and lengthen the time to complete the work.

Drainage of subways often involve very serious difficulties and large expense for storm pumping, etc.

Some of the objections to street elevation are briefly:

The height necessary for viaducts above the original grade of streets requires long approaches.

Property values in the vicinity contiguous to the railways are depreciated in value.

Long and heavy grades for street traffic.

Smoke nuisance is accentuated and property damage is more pronounced.

In studying the problem the principal factors to be considered are the cost, the effect of the operation of trains in connection with grades, industrial tracks, and provision for future possibilities. Where the country is flat it will generally be track elevation, or partial track elevation and street depression; entire track depression would probably be unfeasible and too costly. In locations where summits of ascending track grades are involved street depression would probably be selected, especially if the track grades are such that they can be materially improved and the cost for extra right of way and the scheme in general is not prohibitive.

Usually the study resolves itself in a series of schemes and estimates and the various phases of each are gone over and considered before the final plan is adopted.

In what follows are given the cost of the various structures involved as well as the quantities and unit prices, that will serve for comparative purposes when making preliminary estimates of this character.

**Fill or Excavation.** — The amount of fill, or excavation, for track elevation or track depression, for varying heights, assuming

either to be fully elevated, or depressed, from the original ground line, as shown in Table 33, is as follows:

TABLE 33. FILL AND EXCAVATION.



Height from bottom of rail.	Height, ft. "H."*	Track elevation. Cu. yd. fill per lin. ft. for height "H."*				Height, ft. "H."*	Track depression. Cu. yd. excavation per lin. ft. for height "H."			
		1 track.	2 tracks.	3 tracks.	4 tracks.		1 track.	2 tracks.	3 tracks.	4 tracks.
15.6	14.0	24	32	40	48	18.0	54	66	78	90
16.0	14.6	25	33	41	49	18.6	56	68	80	92
16.6	15.0	26	34	42	50	19.0	57	69	81	93
17.0	15.6	27	35	44	53	19.6	59	72	84	96
17.6	16.0	28	37	46	55	20.0	61	74	87	100
18.0	16.6	30	39	48	57	20.6	63	76	89	102
18.6	17.0	31	40	49	58	21.0	65	78	91	104
19.0	17.6	33	43	52	62	21.6	67	80	93	106
19.6	18.0	35	45	55	65	22.0	68	82	96	110
20.0	18.6	37	47	58	68	22.6	71	85	99	113

\* H = Height from base of rail to ground line, less 18".

For track elevation, assuming that a clearance of 14 ft. is required for subway and the floor depth is 3 feet 6 inches, the height from ground line to base of rail will be 17 feet 6 inches. In the table for this height, the amount of fill per lineal foot of embankment is 28 cubic yards for one track; 37 cubic yards for two tracks; 46 cubic yards for three tracks, etc.

For track depression, assuming that a clearance of 22 feet is required under the street bridge and the depth of floor is 3 feet 6 inches, in the table for the 22-foot height, the amount of excavation per lineal foot is 68 cubic yards for one track; 82 cubic yards for two tracks; 96 cubic yards for three tracks, etc.

By comparing the two cases given, which is a fair average for clearances, etc., it will be noted that the excavation for depression is about two and one-half times that of the fill required for track elevation.

The cost of fill for track elevation as against a cut for track depression is extremely variable depending upon local conditions and other factors that affect the cost, such as kind of material to be excavated in the case of a cut, its disposition, and possible changes to sewers, water mains, etc.; source of material in case of a fill and length of haul; in both cases traffic, bridges, walls, and number of tracks involved, etc., have a bearing on the cost and require to be considered. Material for embankment is usually made by train fill dumped from a temporary trestle which is chargeable to the fill.

The cost of fill for estimating purposes varies from 50 cents to \$1.25 per cubic yard in place. A temporary trestle can be figured at \$8 per lineal foot, if one trestle only is used; where two trestles are required, \$7 per foot for each trestle is a fair figure. The fill for embankment in place under tracks was estimated at 50 cents per cubic yard in Chicago and \$1 per cubic yard at Houston and Toronto for grade separation work undertaken or proposed in these cities.

The material to be excavated in a cut for track depression is usually done by steam shovel and the cost of removing and disposing of it will vary from 30 cents to \$1.50 per cubic yard, depending upon the kind of material, disposition, length of haul, traffic, etc. On the Toronto track depression work the excavation was estimated at \$1.25 per cubic yard.

**Track Depression C. M. & St. P. Ry.** — The C. M. & St. P. Ry. track depression work in Minneapolis consisted in lowering the main tracks of the Hastings & Dakota Division for a distance of about three miles through a mixed residential and industrial section of the city in compliance with a city ordinance which called for the elimination of thirty-nine street crossings at grade. The plan contemplated the depression of the track and the erection of thirty-seven bridges to carry the traffic overhead. One street was closed and another, which originally was carried under the tracks in a subway, now crosses at grade.

The tracks were lowered to permit head-room of 18½ feet under the bridges. This necessitated a cut which averaged about 22 feet in depth. The total excavation was about 900,000 cubic yards and consisted of sand and gravel. A 65-ton Bucyrus steam shovel was used, equipped with a 2½ cubic yard dipper. The

excavated material was hauled to Bass Lake, where it has been utilized for the construction of a freight yard.

The original plan called for a two-track depression, but it was found necessary to increase this to three tracks in order to connect with the industrial spurs and permit the necessary switching without interference with the main line.

**Steam Shovel Work.** — The work was done by the operating department of the railroad with company forces. The total depth of the cut was made in from 5 to 7 cuts, depending upon the depth carried. These cuts were generally carried for a stretch of about eight blocks at a time. The usual method of procedure was to use one track as a loading track while the shovel was making as deep a cut as possible to one side. This usually averaged about 8 feet. When this cut was completed to the required distance, a new track was laid here and used as a loading track while the shovel was shifted to the other side.

The shovel used was a 65-ton Bucyrus equipped with a  $2\frac{1}{2}$  yard dipper and three dirt trains were used consisting of 25, 12-yard Western air dump cars. Each train was hauled by a class C-2 (2-8-0) locomotive.

Below is a statement, prepared by J. G. Wetherell, Assistant Engineer who was in direct charge of the work, for the operating department, for shovel operation from April 19th to July 23rd.

Total amount of excavation for season.....	195,908 cu. yd.
Total number of days shovel worked.....	82
Number of cuts shovel made.....	8
Total distance shovel excavated (total length of cuts).....	16,076 ft.
Average distance excavated per day shovel worked.....	196 ft.
Average number of hours shovel worked per day.....	8.80 hr.
Total number of cars loaded.....	17,107
Average number of cars loaded per day.....	208.6
Average number of cu. yd. per car.....	11.46 cu. yd.
Average number of cu. yd. excavated per day.....	2389.1
Average distance excavated material hauled.....	5.28 mi.
Greatest excavation for 1 month (June).....	72,934 cu. yd.
Average daily excavation for June.....	2805 cu. yd.

Delays amounted to 12 per cent of the total time, distributed as follows:

- 3.4 per cent moving shovel from one cut to next.
- 5.3 per cent no cars, due to trouble at the dump or to main line being used for other purposes.
- 1.3 per cent rain.
- 0.2 per cent shovel breakdowns.
- 0.8 per cent derailments in cut.
- 1.0 per cent miscellaneous.



**Land or Retaining Walls.** — The amount of land occupied by track depression as against track elevation for the same number of tracks depends on the amount of elevation or depression of the tracks. In either case, when the fill or cut overruns the land owned by the Company, it may be necessary, on account of streets or high cost of land, etc., to build retaining walls. Two comparative cases are given below, from which it will be noted that in the case of track elevation with retaining walls the cost is \$161 as against \$393 per lineal foot for track depression.

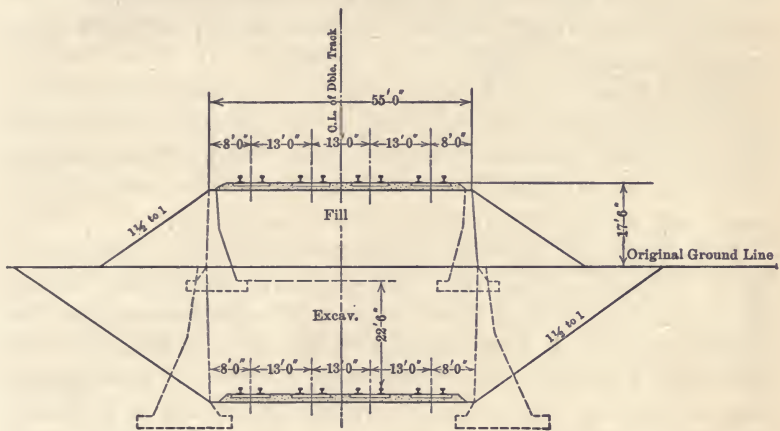

TABLE 34.

APPROXIMATE COSTS OF TRACK ELEVATION AND TRACK DEPRESSION (FOR FOUR TRACKS) PER LINEAL FOOT.

Track elevation with retaining walls.				Track depression with retaining walls.			
Excavation.....cu. yd.	6	\$1.00	\$ 6.00	Excavation.....cu. yd.	113	\$1.00	\$113.00
Backfill.....cu. yd.	3	0.50	1.50	Backfill.....cu. yd.	38	0.50	19.00
Piles, wood.....lin. ft.	60	0.40	24.00	Piles, wood.....lin. ft.	75	0.40	30.00
Drainage.....lin. ft.	.....	.....	1.00	Drainage.....lin. ft.	.....	.....	1.00
Concrete, plain.....cu. yd.	7.6	8.00	60.80	Concrete, plain.....cu. yd.	18	8.00	144.00
Steel reinforcing.....per lb.	500	0.03	15.00	Steel reinforcing.....per lb.	1500	0.03	45.00
Waterproofing walls..sq. yd.	6	0.25	1.50	Waterproofing walls..sq. yd.	9	0.25	4.25
Fill.....cu. yd.	38	1.00	38.00	Supervision and contingencies about 10 per cent.....	.....	.....	36.75
Supervision and contingencies about 10 per cent.....	.....	.....	13.00	Total.....	.....	.....	\$393.00
Total.....	.....	.....	\$161.00				

The figure (Table 34) shows the amount of land occupied by a four-track viaduct or embankment for track elevation, or track depression for the same number of tracks; by comparing the two it will be noted that more land is involved by track depression in any case than track elevation either when the ground or embankment is sloped off or when retaining walls are used.

The walls are usually placed so as to encroach as little as possible beyond the right of way, and are shown in dotted lines for the two conditions, in the case of the depressed tracks where clearances will admit the wall may be reversed to bring the overhanging portion inside instead of outside which will result in reducing the width of right of way involved.

**Type of Walls.** — In the Rock Island track elevation work at Chicago the mass retaining walls, 30 ft. high, cost about \$115 per lineal foot. Retaining walls on this work 18 ft. high, which is a common standard for track elevation projects, cost \$32 per lineal foot, being supported on spread foundations.

Walls made by cribbing up reinforced concrete members of about the same size as track ties have given satisfactory service on several roads and on the Chicago & Western Indiana the cost of such walls, from 7 to 8 ft. high, is stated to be from 14 to 17 per cent of that of a mass wall for same location. This indicates that, at least for low walls, the crib design retains its economic advantages when built of permanent material. Cellular wall designs developed by the Chicago, Milwaukee and St. Paul for track elevation at Milwaukee are also said to be very economical when conditions are favorable.

For further details in regard to retaining walls, the quantities involved, and approximate cost see Chapter VI, also pages 35 and 36.

For Subways see Chapter V.

For Street Bridges see Chapter VI.

For Elevated Structures see Chapter VII.

**Street Grades.** — For track elevation it is usual to allow depression of streets at the crossings so as to give a minimum height of rise of tracks. In some cases the street has been depressed one-third and the tracks elevated two-thirds.

Any depression of streets will usually involve consideration of approach grades on the streets. Easy grades mean longer and

more expensive approach grades and greater property damage. On the other hand steep grades with the advent of the automobile and other tractive power machines are not so detrimental to the general run of traffic as was the case formerly when horse traffic was the principal consideration.

In the Chicago track elevation work a great number of the subways have been built with 3.5 per cent approaches for an average length of about 100 feet on each side of the subway, the street depression averaging three to four feet. In several cities the grades vary from 3 to 9 per cent depending upon the district, whether residential or commercial, and the characteristics of the location and the amount of money involved.

The level portion of the street on which cars are run should extend far enough beyond the subway to permit of maximum height to clear structure before starting up the grade. The grade and level portion should be connected by a vertical curve.

In work of this character it should be noted that in cities labor will usually be high, the prices paid will always be compared with the rates paid by the city and it is quite possible it may be stipulated that contractors pay city rates for labor which is usually very much higher than the general run of wages paid for ordinary unskilled labor by contractors.

APPROXIMATE COST OF VARIOUS ROADS AND STREETS.

Type of street pavement.	Average cost per sq. yd.	Kind of street.
Asphalt on concrete base.....	\$2.25	Residential street
Asphalt on concrete base.....	3.00	Heavy traffic
Brick.....	2.15	Car line street
Concrete, plain.....	1.55	Alleys
Granite block.....	4.00	Heavy traffic
Macadam — water bound.....	1.25	Light traffic
Wood blocks creosoted.....	3.00	Business street
Tar or asphalt macadam.....	1.50	Light traffic

Street paving has been estimated at \$18.00 per lin. ft. of 65 ft. street with brick paving on a concrete base, concrete sidewalks and concrete curb and gutter.

Street excavation has been estimated at 75 cents per cubic yard for lowering street grades, the work being expensive on account of interference with traffic and difficulty of drainage during progress of work.

**Sewer and Pipes.** — A reasonable estimate is to take \$15.00 per foot for every pipe crossing track.

**Closing of Streets.** — It may be necessary to close some streets and readjust routes of street traffic to locations where it is possible to locate a subway or bridge to better advantage. There is generally considerable opposition to this on the part of property owners affected and such are usually settled by negotiation and compromise.

**Clearances.** — The following table gives the vertical clearances which have been used in a number of cities under varying conditions as given by C. N. Bainbridge.

Clearances in feet of bridges over street.			Clearances in feet of bridges over tracks.		
Location.	Streets without street cars.	Streets with street cars.	Location.	Clearances.	Clearance side.
Chicago.....	12-13	13.5	Chicago.....	16-18	....
Philadelphia....	14	14	Philadelphia....	20	....
New York.....	14, usual, 11 and 12 special	14	Rhode Island....	18	....
Buffalo.....	13	14	Connecticut.....	18	....
Evanston.....	12-13	13.5	New York City..	16-18	....
Kansas City....	13	14.5	New York State..	21	....
Cleveland.....	13	14.5	Massachusetts...	18	....
Detroit.....	13	14	Buffalo.....	15-18	....
Milwaukee.....	12	13.5	Minneapolis.....	18-18.5	....
			North Dakota...	21	8
			Canada.....	22.5	....
			Kentucky.....	22	....
			Cleveland.....	16.25	....
			New Hampshire..	21	....
			Michigan.....	18	....
			Minnesota.....	21	8
			Vermont.....	22	7.5
			Indiana.....	21	7

**Equipment:** The following figures may be considered fair average rental rates on equipment for grade separation work.

TABLE 35.—COST AND RENTAL RATES ON EQUIPMENT FOR GRADE SEPARATION WORK ON THE N. Y. C. & ST. LOUIS RY AT CLEVELAND.

Kind of equipment.	Cost.	Rental.	Remarks.
Locomotives.....		\$ 3.40 per hr. incl., eng. and train crews	
<i>Unloading equipment:</i>			
Lidgerwood unloader (60 tons).....	\$5972	10.00 per day	
Jordan spreaders.....	3350		
Two plows.....			
<i>Steam shovel:</i>			
70 ton bucyrus.....		10.00 per day	
Two tool cars.....		0.50 per day, each	
Loco. crane No. 8.....	6207	7.00 per day	
Loco. crane No. 9.....	6517	7.00 per day	
Loco. crane No. 10.....	6475		
Loco. crane fitted with leads for driving piles.	\$206 6681	7.00 per day	\$206 does not incl. cost of hammer.
<i>Concrete mixer No. 1:</i>			
2½ mixer; 9 h.p. vert. eng., hoisting engine; 20 h.p. boiler on flat car and housed; 7.24 cu. ft. side disch'ge concrete cars; 29 chutes, 600 ft. track, etc., set up and ready for service.	3016	5.00 per day	Does not incl. cost or rental of car.
<i>Concrete mixer No. 3.....</i>			
Pile driver Bucyrus mounted on car.....	Leased	3.00 per day	
Pile driver, mounted on wooden rolls and skids.	Leased	10.00 per day	
		4.00 per day	
<i>Trench machine.....</i>			
		167.50 per month	
<i>Steam pump (6-in.) 10-h.p. vert. boiler with hose and fittings.</i>			
	511	2.60 per day	
<i>Compressed air plant, 150 cu. ft. per min. Air-gas'l eng., etc., mounted on flat car and housed.</i>			
	1650	1.50 per day	Does not incl. cost or rental of car.
<i>Portable saw bench, 2 12-in. saws and gasoline engine.</i>			
	165		
<i>Apron flat cars.....</i>			
		0.45 per day	Including repairs.

The method used in establishing rental values for equipment as above (by A. J. Himes) is illustrated by the case of crane 8, as follows:

Cost of crane delivered and set up ready for service.....	\$6207.00
Depreciation for one month @ 10 per cent per year.....	51.73
Interest for one month @ 6 per cent per year.....	31.04
Coal, oil and supplies one month.....	28.60
Watchman, one month.....	60.00
	<u>\$171.37</u>

\$171.37 expense and depreciation per month, divided by 26, working days per month, equals \$6.59 per day, say \$7.00 per day.

## CHAPTER V.

## TUNNELS AND SUBWAYS.

**Tunnels.** — Any tunnel work will usually require a special survey and careful investigation before being undertaken.

They are generally built straight, and are usually dug from each end.

The construction depends on the nature of the material; in very soft ground a circular cross section is used or an inverted arch along the bottom with tapering sides and a semi-circle along the top.

The general construction is usually a rectangle with a semi-circle or semi-ellipse top, lined on the inside and graded throughout its length so as to drain with open gutters on the sides.

When wood lining is used it is made extra wide so as to allow for a permanent lining at a future date.

Any crevices made by the material falling outside of the construction line are filled with dry broken stone, rock, or split cord wood.

When intermediate shafts are built they are generally closed up when the tunnel is complete, as they tend to produce cross currents of air, which retard ventilation. The movement of the train through the tunnel is said to be the best ventilator. In long tunnels power-driven fans are sometimes used.

Where artificial ventilation is necessary for tunnels carrying steam power traffic it is usually obtained by one of two methods, as recommended by the A. R. E. Assoc:

(a) To blow a current of air in the direction the train is moving and with sufficient velocity to remove the smoke and combustion gases ahead of the engine.

(b) To blow a current of air against the direction of the tonnage train with velocity and volume sufficient to dilute the smoke and combustion gases to such an extent as not to be uncomfortable to the operating crews and to clear the tunnel entirely within the minimum time limit for following trains.

**Tunnel Sections.** — Very few tunnels are built without some form of lining as the best rock is liable to swell and fall and cause trouble; a timber lined tunnel is in danger of fire from locomotives so that if a permanent lining is not built in the first place provision is made so that it can be carried out at a future date.

As the nature of the material to be pierced is usually of a varying character the cross sections illustrated are typical of the different structures used under ordinary conditions. In yielding material the section of the tunnel is made large enough to be concrete lined without removing the timbers. Where the character of the material permits the timber lining is removed after the tunnel is driven and replaced with concrete. Where excessive pressure is likely to occur on account of inclined strata of rock, steel reinforcement is introduced, Fig. 6. The form and dimensions of the clear space to be provided for single and for double track tunnels on tangents as given by the A. R. E. A.

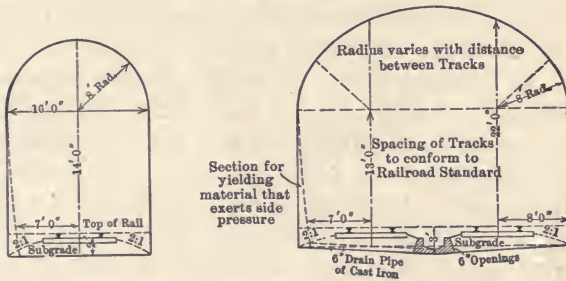

Fig. 1. A. R. E. A. Tunnel Clearances.

are shown, Fig. 1. For tunnels on curved track the section should be increased and the track shifted over so as to provide the same clearance as for tangent; the rate of grade in long tunnels should be reduced so as to be 25 per cent, less than that of the ruling grade. The form and dimensions of the four-track Bergen Hill tunnels on the Erie Railroad are shown, Fig. 2. The distance between tracks is 13 ft. and the clearance of the inner tracks is 8 ft. 6 in. from center to face of wall. A box is built at each side of tunnel for drainage and 4 in. tile is used at low spots. The tracks are carried on a 12 in. bed of ballast on a broken stone base.

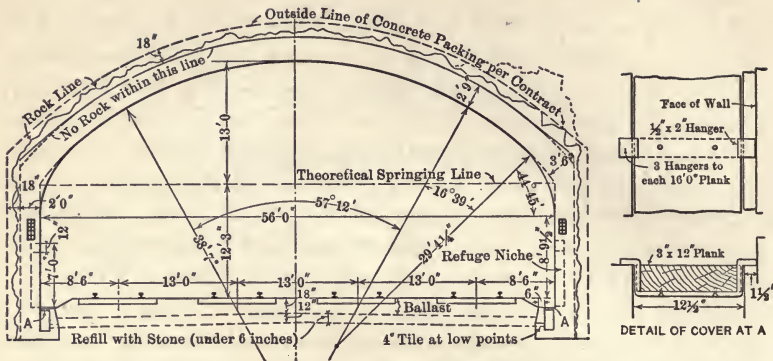

Fig. 2. Cross Section Four-track Tunnel Bergen Hill Tunnels, Erie Ry.

**Tunnel Driving.** — The drilling methods adopted for tunnel driving on the C. C. & O. Ry. are typical for this class of work, Fig. 3. One of these was by first driving a bottom heading and then throwing the superincumbent mass downward into a muck pile to be removed by steam shovels and cars as per sketch A. & B. In this case where the muck pile was high enough the drills were put straight into the face of the top heading as per sketch C, but when the muck pile was not high enough for this, the drills were driven in from beneath, as in sketch D. The method principally used however was to first take out a top heading with a semi-circular roof 9 ft. high at the center, forming the arch of the tunnel, sketches E, F and G, and then blast out the bench and remove by steam shovel.

In the tunnel work 60 per cent dynamite was principally used, making less fumes and securing quicker ventilation of the tunnel than was possible with the Judson powder; and 40 per cent dynamite was used on the outside rock work.

The general cross sections of the tunnel construction both for wood and concrete as well as steel rib reinforcement are shown in Figs. 6, 7, 8 and 9 and may be taken as typical for this class of work. The approximate cost and quantities for the different sections are given on pages 71, 72 and 73.



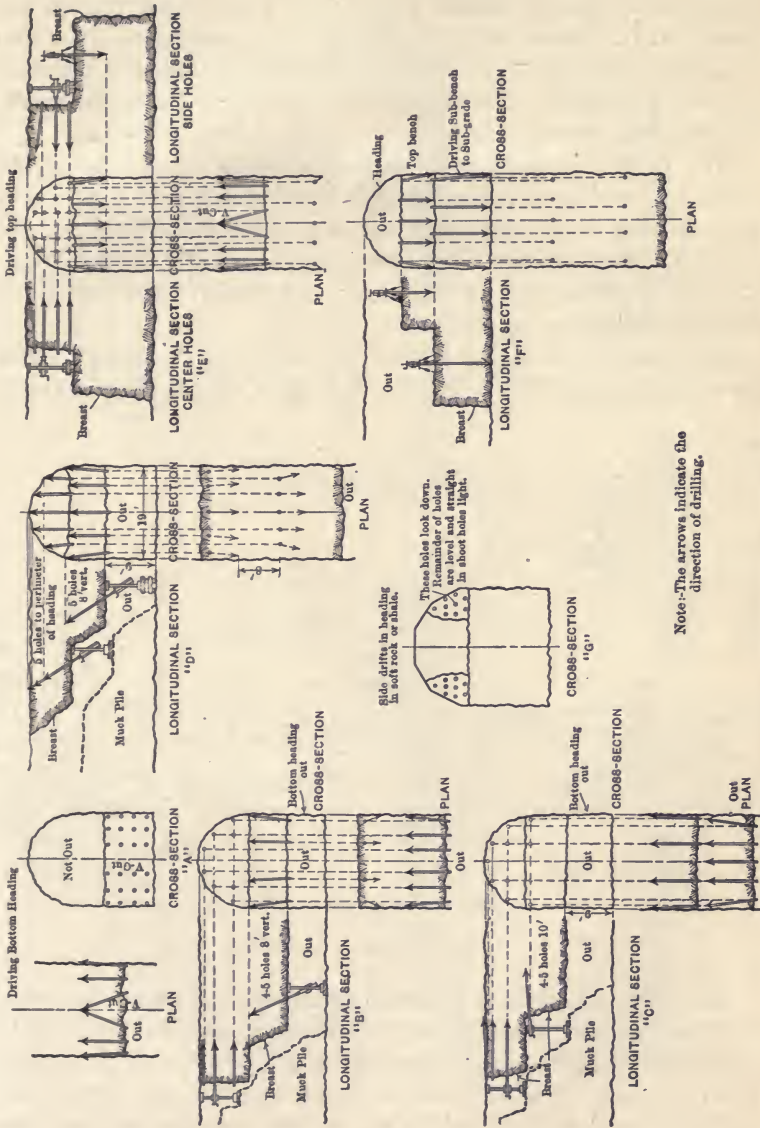

Note: The arrows indicate the direction of drilling.

Fig. 3. Typical Drilling Methods for Tunnel Driving, C. C. & O. Ry.

A novel method adopted in the construction of the Connaught double track tunnel on the C. P. R. consisted in driving from each end a pioneer tunnel parallel with the main tunnel but about 50 ft. distant from it. From the pioneer tunnels, cross-cuts were driven to the center line of the main tunnel at intervals of 1400 to 3000 ft. From each of these points the main tunnel heading was driven.

The pioneer tunnels were merely a means of expediting the work by producing numerous points of attack and it is stated that the cost of the work and rate of progress amply justified the auxiliary tunnel work. The main tunnel is 26,400 ft. long, 29 ft. wide at rail level with vertical sides and semi-circular roof 23 ft. above subgrade to crown.

An isometric elevation and cross sections of the tunnel taken from Engineering News, Vol. 74, No. 20, is shown, Figs. 4 and 5.

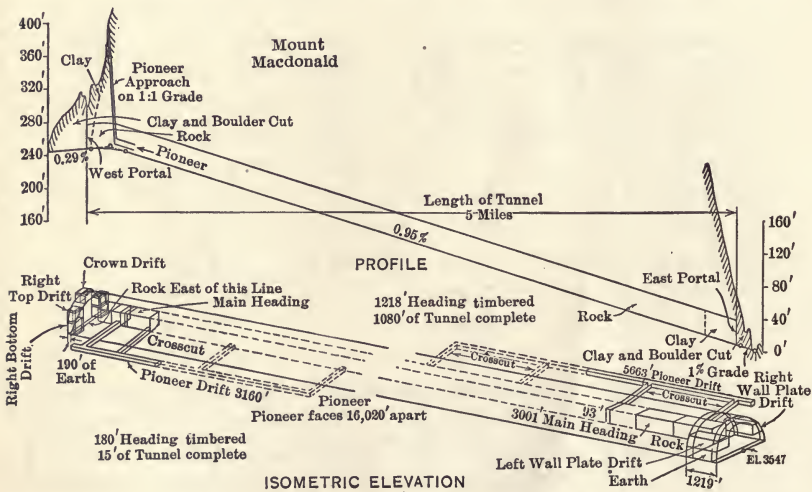

Fig. 4. Isometric Section and Profile.

With the exception of several hundred feet of clay and glacial drift at each end, the drifts are in solid rock, which is expected to continue throughout the entire length. It is mainly slate, schist and quartzite. No timbering is required in the rock excavation.

For the end portions, which are in loose material and are timbered, a concrete lining is required. This is 30 in. thick and 483

Double Track Tunnel.

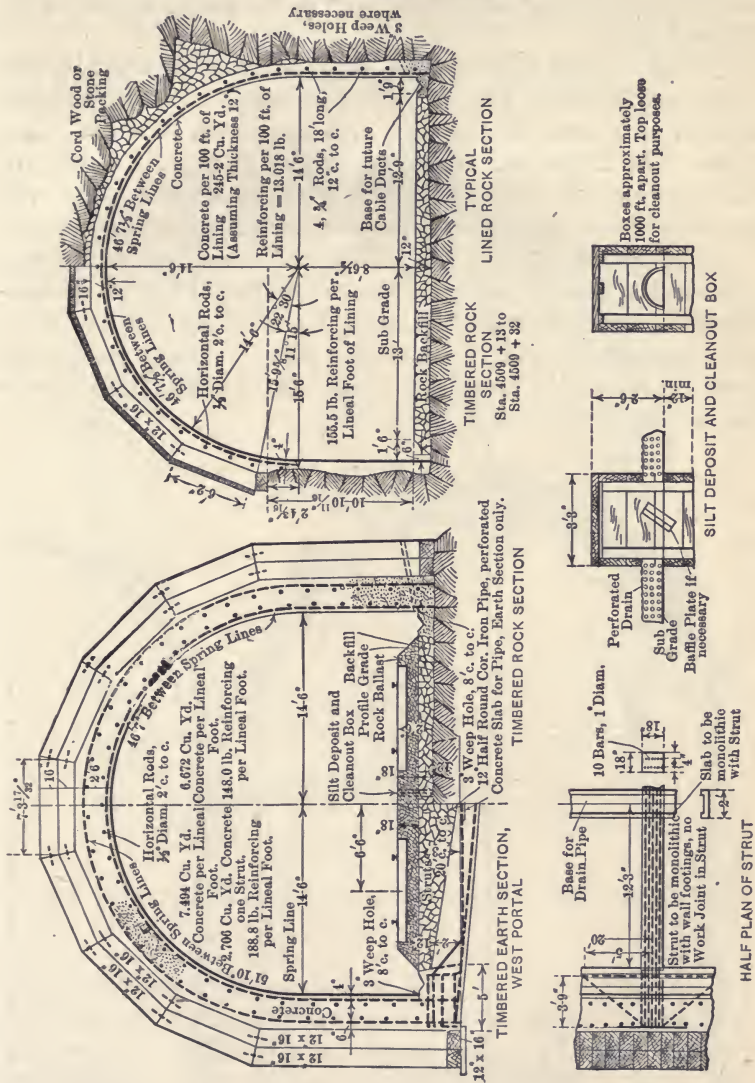

Fig. 5. Section Connaught Tunnel.

ft. long at the west end and 27 in. thick and 1,288 ft. long at the east end. In addition, on account of the spalling of the rock, some concrete lining may be required in the solid-rock section at the west end.

Typical sections of the tunnel, with its timbering and concrete lining, are shown in Fig. 5. The timbering in the glacial drift consists of a semi-circular roof arch supported on  $12 \times 16$ -in. posts. The timber sets are usually spaced 18 in. c. to c., but are set close where the material is loose and contains water. The arch has five or seven segments, usually single, but sometimes double.

An interesting feature is that for the lined section in loose material the heavy footings of the side walls are braced by reinforced-concrete struts 20 ft. apart. These are 18 in. wide, 24 in. deep at the ends and 18 in. at the middle. They are formed monolithic with the footings and with the longitudinal concrete slab for the support of the track drain.

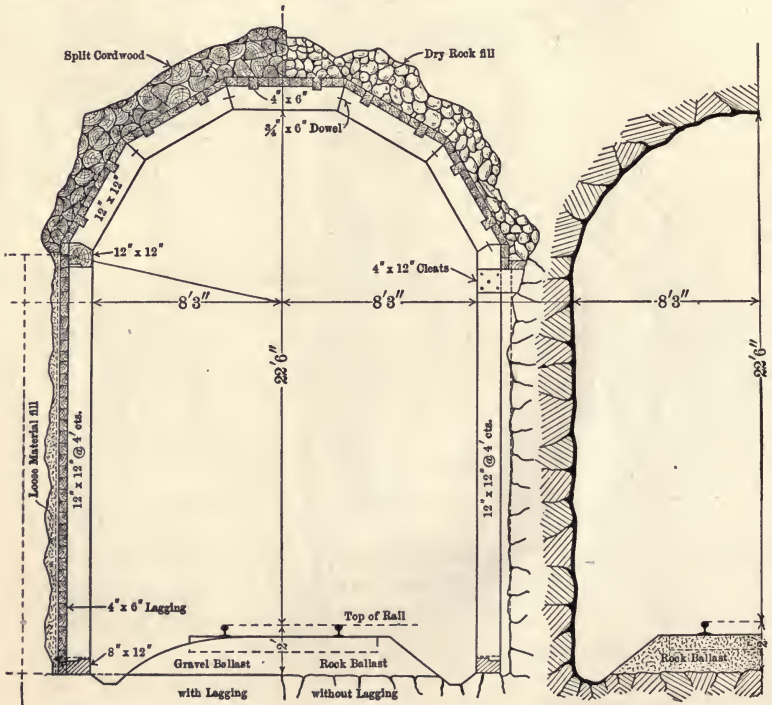

Fig. 5a. Ordinary Single Track Tunnels.

**Construction.** — For ordinary tunnel work, Figs. 5a and 9, the timbers generally consist of 12" × 12" upright posts at varying centers usually not over 3 ft., with 12" × 12" caps and arch beams, 4" sills and 4" lagging the space behind being filled with wood or stone packing. The concrete lining may consist of 1 : 2 : 5 material for side walls, and 1 : 2 : 3 for arch.

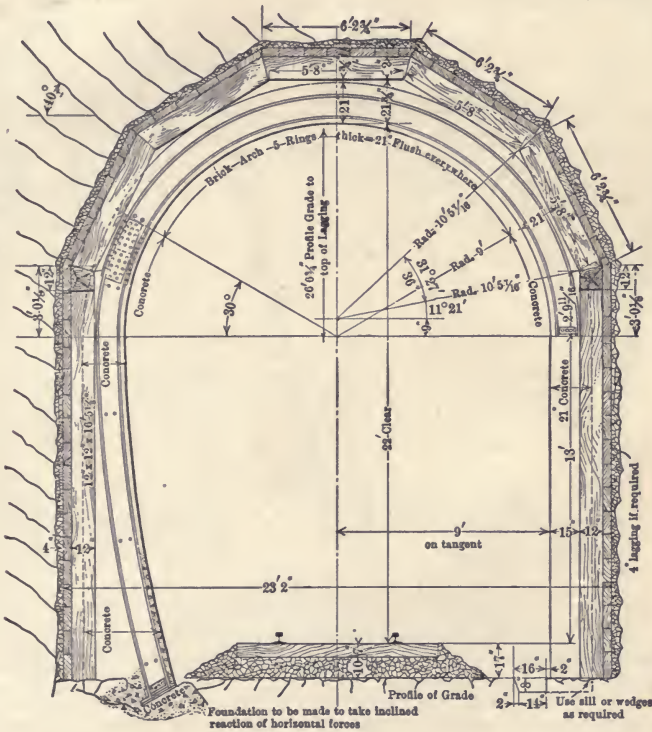

Fig. 6. Concrete Tunnel Lining with Steel Rib Reinforcement, C. C. & O. Ry.

The steel reinforcement used on the C. C. & O. Ry., Fig. 6, consists of 12" I beam ribs at 2 to 3 ft. centers, in two curved sections spliced together just above the springing line of the arch, at the most dangerous points the ribs are placed 12" centers, the ribs being carried down to the floor of the tunnel only on the side from which the pressure occurs.

The A. R. E. A. recommend that concrete be used for the permanent tunnel lining except where local conditions will injure the concrete before there is time for it to harden.

In the event that a brick lining be used, that portion of the arch for a horizontal distance of five feet on each side of the center line of each track should be laid with vitrified brick in rich Portland cement mortar.

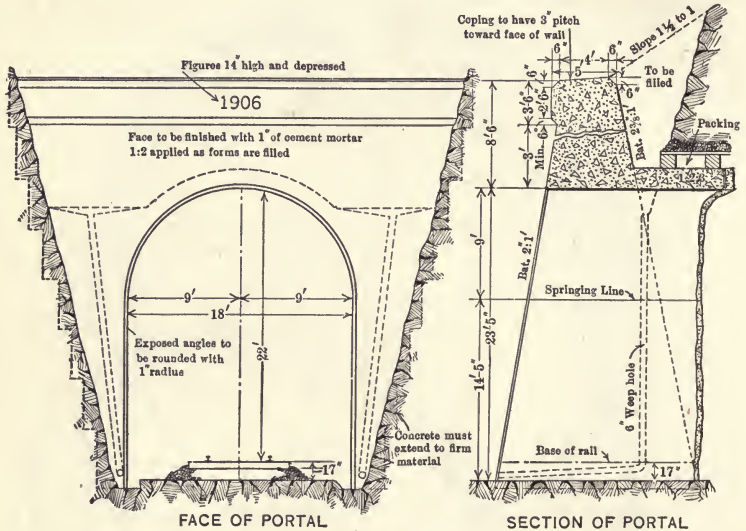

Fig. 7. Concrete Tunnel Portal, C. C. & O. Ry.

**Tunnel Portals.**— Fig. 7 illustrates a permanent type of portal as built on the C. C. & O. Ry. The face is finished with one in. of one to one cement mortar applied as forms are filled. It is usual to elaborate the face of permanent portals with a view of giving them a monumental appearance. When timber is used, the end portals consist of 12 in. by 12 in. posts spaced two feet centers or less, for a distance of about 8 feet from the ends, with 12 in. by 12 in. timbers built over and across the end posts, to form a retaining wall on top; the end walls are also braced with similar timbers forming wing walls parallel to the tracks with lining behind if necessary to take the end slope of the hill; the brace posts are secured at the bottom by extending the main sill.

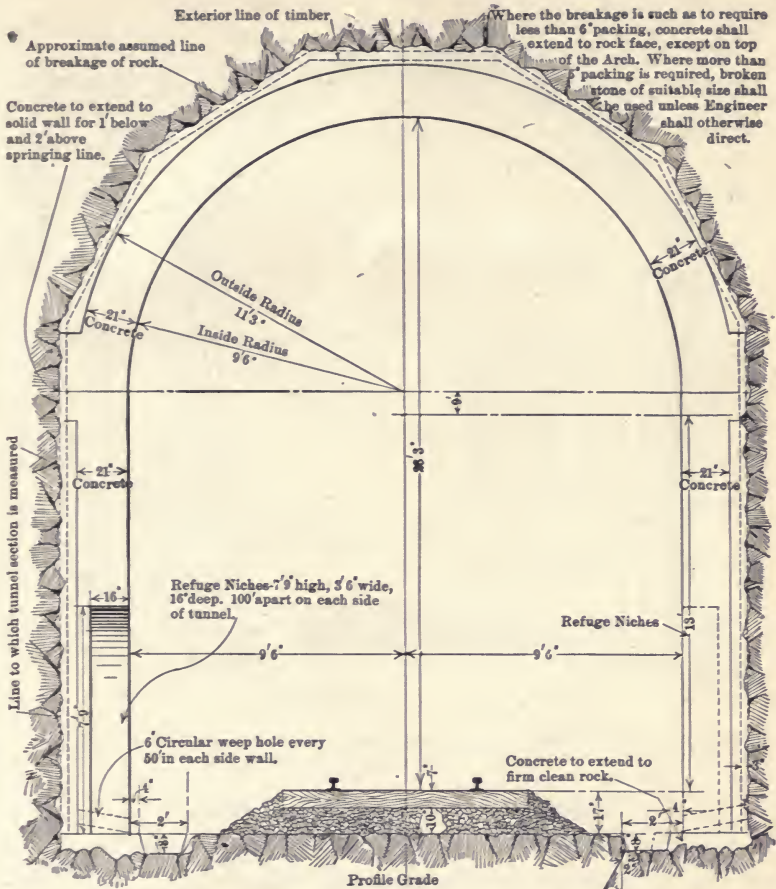

Fig. 8. Tunnel Lining. Plain Concrete, C. C. & O. Ry.

TUNNEL CONCRETE LINED AFTER REMOVING TIMBER. (Fig. 8.)  
 APPROXIMATE COST PER LINEAL FOOT, WITHOUT TRACK.

15 cu. yd. Excavation.....	@ \$3.25	\$ 48.75
450 F. B. M. Timber.....	@ 40.00	18.00
45 lb. Iron in timber.....	@ 0.06	2.70
1 cu. yd. Breakage.....	@ 1.00	1.00
Packing and weep drains.....		1.55
Freight, 1 ton.....	@ 4.00	4.00
4 cu. yd. Concrete.....	@ 10.00	40.00
		<u>\$116.00</u>
Supervision and contingencies, about.....	10 per cent	11.00
Total.....		<u>\$127.00</u>

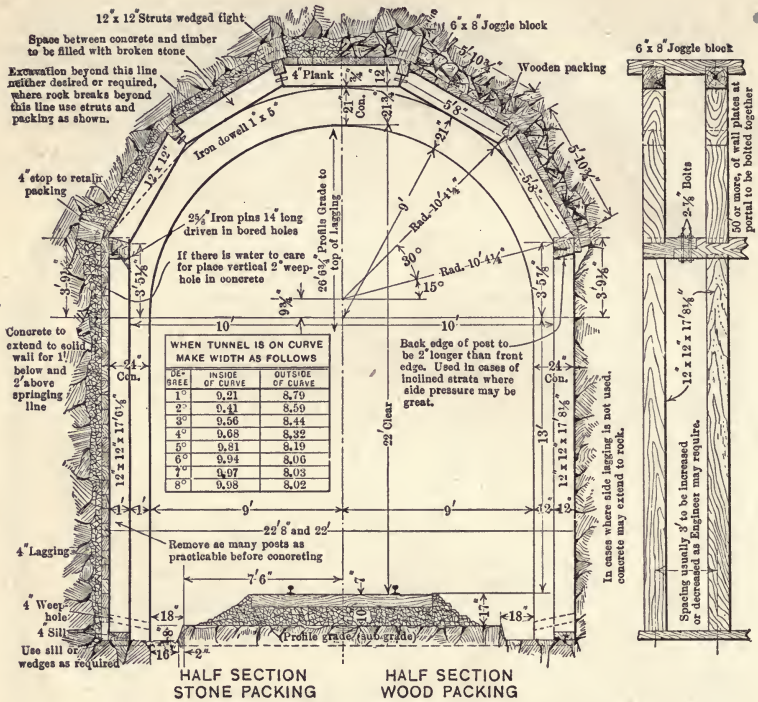

Fig. 9. Tunnel Concrete Lining Inside of Timbering, C. C. & O. Ry.

Approximate Costs of Tunnel Work.

TUNNEL LAGGED THROUGHOUT AND CONCRETE LINED. (Fig. 9.)

APPROXIMATE COST PER LINEAL FOOT, WITHOUT TRACK.

19 cu. yd. Excavation	..... @ \$3.25	\$ 61.25
650 F. B. M. Timber	..... @ 40.00	26.00
65 lb. Iron in timber	..... @ 0.06	3.90
2 cu. yd. Breakage	..... @ 1.00	2.00
Packing and weep drains	.....	1.85
Freight, 1 1/2 tons	..... @ 4.00	6.00
		<u>\$101.00</u>
4 1/2 cu. yd. Lining	..... @ 10.00	45.00
		<u>\$146.00</u>
Supervision and contingencies, about	..... 10 per cent	14.00
Total	.....	<u>\$160.00</u>



TUNNEL LAGGED OVER ARCH ONLY AND CONCRETE LINED. (Fig. 9.)

APPROXIMATE COST PER LINEAL FOOT, WITHOUT TRACK.

18 cu. yd. Excavation.....	@ \$3.25	\$ 58.50
500 F. B. M. Timber.....	@ 40.00	20.00
50 lb. Iron in timber.....	@ 0.06	3.00
1 cu. yd. Breakage.....	@ 1.00	1.00
Packing and weep drains.....		1.50
Freight, 1 ton.....	@ 4.00	4.00
		<u>\$ 88.00</u>
4 cu. yd. Concrete lining.....	@ 10.00	40.00
		<u>\$128.00</u>
Supervision and contingencies, about.....	10 per cent	12.00
Total.....		<u><u>\$140.00</u></u>

Average unit prices for double track tunnel work, 1915:

Excavation	Rock per lineal ft.....	\$135.00
	Earth per lineal ft.....	245.00
	Average per lineal ft.....	142.00
	Extra account lining per cu. yd.....	3.00
Back filling	Wood per cord.....	7.50
	Rock.....	2.25
Lining	Timber per M. ft. B. M.....	40.00
	Concrete per cu. yd.....	13.50
	Average cost per foot.....	81.00
	Trackwork per foot.....	6.50

FROM DRINKER'S TUNNELING.

Material.	Cost per cubic yard.				Cost per lineal foot.	
	Excavation.		Masonry.		Single.	Double.
	Single.	Double.	Single.	Double.		
Hard rock.....	\$5.89	\$5.45	\$12.00	\$ 8.25	\$ 69.76	\$142.82
Loose rock.....	3.12	3.48	9.07	10.41	80.61	119.26
Soft ground....	3.62	4.64	15.00	10.50	135.31	174.42

The Can. Nor. double track tunnel under Mount Royal, Montreal, Canada, is said to have cost, excluding track and ballast per foot..... \$208.00

The Can. Pac. double track tunnel between Hector and Yield is said to have cost, excluding track and ballast, per foot..... \$150.00

**Tunnel Ventilation.** — An improved system of ventilating some of the tunnels on the mountainous regions in West Virginia between Clarksburg and Parkersburg consisting of revolving fans propelled by steam power plants located near the portals, which drives fresh air ahead of the trains and insures comfortable temperatures, cost \$70,000 each.

**Tunnel Floors.** — The A. R. E. A. recommended for double track tunnels that the drainage should be provided for by the construction of a concrete channel midway between the tracks.

Figs. 10 and 11 show the arrangement adopted in the Rivermont tunnel (Southern Ry.) and the Richmond St. Tunnel, M. St. P. & S. Ste. M.

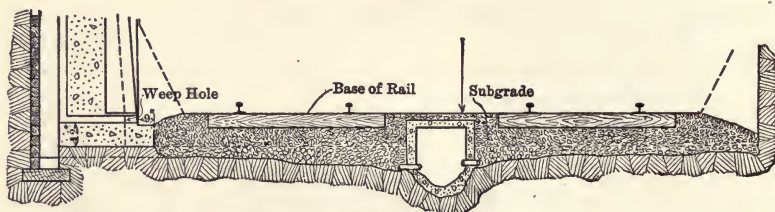

Fig. 10. Rivermont Tunnel (Southern Ry.).

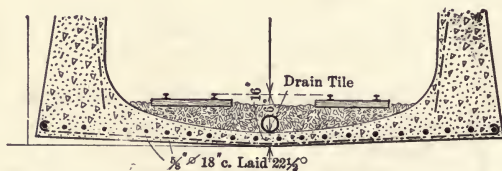

Fig. 11. Section Tunnel (M. St. P. & S. Ste. M.).

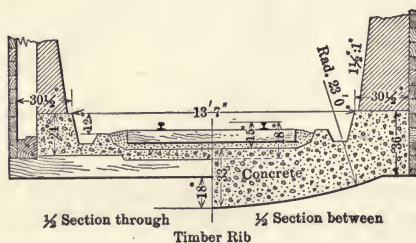

Fig. 12. Tunnel on Everett & Monte Cristo.



## SUBWAYS.

The type of subway to adopt will, under ordinary conditions, depend upon the number of supports the city or municipality will allow in the street; usually four types can be considered.

- A. One span — full width of street.
- B. Two spans — supports in center of street.
- C. Three spans — supports at sidewalk curb lines.
- D. Four spans — supports at sidewalk curb lines and center of street.

The usual clearance of subways is 12 ft. to 13 ft. for streets without street cars and 13' 6" to 14' 6" for those with street cars.

In all types the aim is to keep the floor as thin as possible so as to limit the height and thereby reduce the amount for fill in embankment, consistent with construction that will produce water tightness, noiselessness, good drainage, and easy maintenance, avoiding projections extending above the rail unless proper clearance is provided to make it safe for trainmen. A type of floor construction that is very common is shown, Fig. 15; the depth of floor is only 2'  $\frac{7}{8}$ " and the girders project about 1 ft. above the base of rail. The floor is composed of 9"  $\times$  10" steel eye beams 15" apart, concrete filled, over which is placed a waterproof membrane and the ballast.

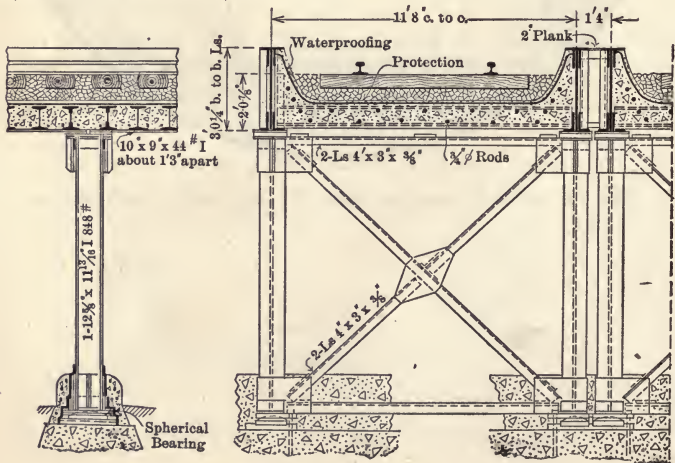

Fig. 15. Shallow Floor.

In Chicago the street subways are in general 66 ft. wide between abutments with curb lines 10 ft. from the walls. At the center of the subway a space about 3 ft. wide is taken for a line of columns and the wheel guards. This leaves about 21' 6" for roadway, which permits street cars and fast vehicles to pass slower vehicles moving in the same direction.

For wider streets the 66 ft. subway is usually maintained, except at boulevards.

The sidewalks are narrowed to 10 ft. to make up for the space occupied by the central row of columns and their clear width is further reduced to about 8 ft. by a line of columns just inside the 10 ft. width.

The spacing of tracks is generally 13 feet centers and if long spans have to be adopted it means that the girders must necessarily project above the base of rail, resulting in greater hazard to railway employees.

The four span subway permits the use of forms of construction which will give a clear area over the bridge, thereby eliminating projecting girders entirely.

The desire to get a shallow floor so as to limit the height and thereby reduce the amount for filling embankments has created a number of different types that differ principally in regard to the floor design.

The advantage of a ballasted floor of proper depth with a waterproofed base as compared with the deck steel plate floor with little or no ballast is considered sufficient to warrant the adoption of the former even at the expense of some additional height, and the present day designs that are most in evidence consist of a combination of steel and concrete with a ballasted floor having at least a 6-in. cushion of ballast under the ties. The floor is made waterproof by using mastic asphalt or other material put on hot over the concrete and allowed to thoroughly set before the ballast is placed, with as much additional aid as possible from dishing or grading the concrete floor so as to form runoffs whereby the water coming through the ballast will always flow to the drainage outlets. The main girders are still confined principally to the deck or through plate girder type, although in many cases reinforced concrete with slab floor construction is being adopted.

Comparative costs of two-track subway structures for 60, 66 and 80 ft. streets for track elevation from estimates, with slight modifications, by C. N. Bainbridge, are for Coopers E 50 loading with track and girders 13 ft. centers. Depth of floor for steel structures 3 ft. 6 in. and for concrete structures 3 ft. 10 in.

Paving and sidewalks have been figured on the basis of the right of way being 100 ft. wide.

Abutments and piers for a loading of from 2 to  $2\frac{1}{2}$  tons per sq. ft. Rails, ties, ballast, drainage of subways, excavation for street depression, etc., that may be considered as common to all structures, have not been included.

TABLE 36. — ESTIMATES FOR CONCRETE REINFORCED BRIDGES.

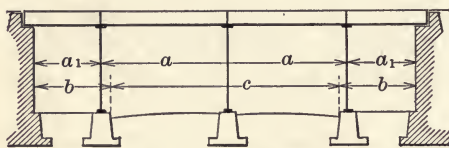

The diagram shows a cross-section of a four-span concrete subway structure. It features four spans supported by three piers and two abutments. Dimensions are labeled as follows:  $a_1$  is the width of the abutment;  $a$  is the length of each of the four spans;  $b$  is the width of the sidewalk on each side; and  $c$  is the total width of the structure between the two abutments.

	$a_1$	$a$	$b$	$c$
60-ft. street...	10.6	19.6	12	36
66-ft. street...	9.6	23.6	11	44
80-ft. street...	16.6	23.6	18	44

TYPE "D" FOUR-SPAN CONCRETE SUBWAYS (2 tracks, 13 ft. c'ts).

Material, type D.	60-ft. street.		66-ft. street.		80-ft. street.				
	cu. yd.	\$	cu. yd.	\$	cu. yd.	\$			
Conc. slab.....	140	\$14.00	\$1,960	168	\$14.00	\$2,350	212	\$14.00	\$2,980
Conc. columns.....	55	21.00	1,155	55	21.00	1,155	59	21.00	1,240
Conc. footings.....	68	8.00	545	68	8.00	545	76	8.00	610
Excav. column footings.....	150	1.00	150	150	1.00	150	170	1.00	170
Backfill column footings.....	60	0.25	15	60	0.25	15	65	0.25	15
Conc. abutments.....	420	7.00	2,940	420	7.00	2,940	420	7.00	2,940
Excav. abutments.....	325	1.00	325	325	1.00	325	325	1.00	325
Backfill abutments.....	160	0.25	40	160	0.25	40	160	0.25	40
Paving right of way 100 ft.....	400	3.25	1,300	490	3.25	1,590	490	3.25	1,590
Sidewalk right of way 200 ft.....	2400	0.15	360	2200	0.15	330	3600	0.15	540
Waterproofing.....	1725	0.20	340	1900	0.20	380	2240	0.20	450
Falsework.....	160	8.00	1,280	172	8.00	1,360	200	8.00	1,600
Eng. and contingencies.....20%	.....	.....	2,090	.....	.....	2,200	.....	.....	2,500
Total.....	.....	.....	\$12,500	.....	.....	\$13,400	.....	.....	\$15,000
Each additional track costs.....	.....	.....	\$4,200	.....	.....	\$4,500	.....	.....	\$5,300

TABLE 37.—ESTIMATES FOR STEEL SUBWAY BRIDGES (STEEL EYE BEAM AND CONCRETE FLOOR).

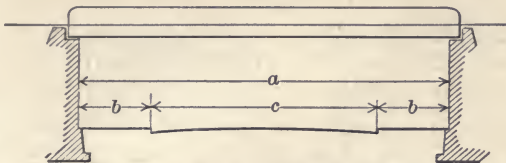

	a	b	c
60 Ft. Street	60	12	36
66 " "	66	11	44
80 " "	80	18	44

TYPE " A " ONE-SPAN SUBWAY (2 tracks, 13 ft. c'ts)

Material, type A.	60-ft. street.			66-ft. street.			80-ft. street.		
Steel structure.....lb.	180,000	\$0.03	\$5,400	207,000	\$0.03	\$6,210	285,000	\$0.03	\$8,550
Conc. floor.....cu. yd.	52	18.00	930	57	18.00	1,030	69	18.00	1,240
Conc. abutments.....cu. yd.	530	7.00	3,710	530	7.00	3,710	530	7.00	3,710
Excav. abutments.....cu. yd.	350	1.00	350	340	1.00	340	340	1.00	340
Backfill abutments....cu. yd.	120	0.25	30	120	0.25	30	120	0.25	30
Paving right of way...sq. yd.	400	3.25	1,300	490	3.25	1,590	490	3.25	1,590
Sidewalk right of way..sq. ft.	2,400	0.15	360	2,200	0.15	330	3,600	0.15	540
Waterproofing.....sq. ft.	1,725	0.20	340	1,900	0.20	380	2,240	0.20	450
Falsework.....lin. ft.	160	8.00	1,280	172	8.00	1,380	200	8.00	1,600
Eng. and conting's....20%			2,700			3,000			3,650
<b>Total</b> .....			<b>\$16,400</b>			<b>\$18,000</b>			<b>\$21,700</b>
Each additional track costs.....			<b>\$6,000</b>			<b>\$6,700</b>			<b>\$8,200</b>

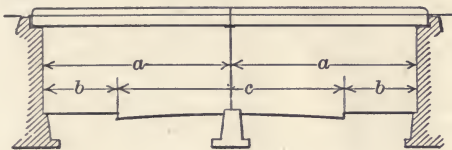

	a	b	c
60 Ft. Street	30	12	36
66 " "	33	11	44
80 " "	40	18	44

TYPE " B " TWO-SPAN SUBWAY (2 tracks, 13 ft. c'ts).

Material, type B.	60-ft. street.			66-ft. street.			80-ft. street.		
Steel structure.....lb.	133,000	\$0.03	\$3,990	158,000	\$0.03	\$4,740	208,000	\$0.03	\$6,240
Conc. floor.....cu. yd.	52	18.00	935	57	18.00	1,030	69	18.00	1,240
Conc. abutments.....cu. yd.	530	7.00	3,710	530	7.00	3,710	530	7.00	3,710
Excav. abutments.....cu. yd.	340	1.00	340	340	1.00	340	340	1.00	340
Backfill abutments....cu. yd.	120	0.25	30	120	0.25	30	120	0.25	30
Conc. piers.....cu. yd.	21	8.00	170	23	8.00	185	26	8.00	205
Excav. piers.....cu. yd.	40	1.00	40	40	1.00	40	50	1.00	50
Backfill piers.....cu. yd.	20	0.25	5	20	0.25	5	20	0.25	5
Paving right of way...sq. yd.	400	3.25	1,300	490	3.25	1,590	490	3.25	1,590
Sidewalk right of way..sq. ft.	2,400	0.15	360	2,200	0.15	330	3,600	0.15	540
Waterproofing.....sq. ft.	1,725	0.20	340	1,900	0.20	380	2,240	0.20	450
Falsework.....lin. ft.	160	8.00	1,280	172	8.00	1,380	200	8.00	1,600
Eng. and conting's....20%			2,500			2,740			3,200
<b>Total</b> .....			<b>\$15,000</b>			<b>\$16,500</b>			<b>\$19,200</b>
Each additional track costs.....			<b>\$ 5,400</b>			<b>\$5,800</b>			<b>\$6,900</b>

TABLE 38.— ESTIMATES FOR STEEL SUBWAY BRIDGES (STEEL EYE BEAM AND CONCRETE FLOOR).

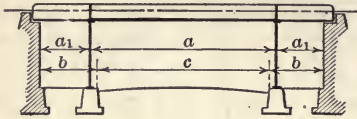

	$a_1$	$a$	$b$	$c$
60 Ft. Street	10.6	39	12	36
66 " "	9.6	47	11	44
80 " "	16.6	47	18	44

TYPE "C" THREE-SPAN SUBWAY (2 tracks, 13 ft. c'ts).

Material, type C.	60-ft. street.			66-ft. street.			80-ft. street.		
Steel structure.....lb.	141,000	\$0.03	\$4,230	168,400	\$0.03	\$5,050	190,000	\$0.03	\$5,700
Conc. floor.....cu. yd.	52	18.00	930	57	18.00	1,030	69	18.00	1,240
Conc. abutment.....cu. yd.	530	7.00	3,710	530	7.00	3,710	530	7.00	3,710
Excav. abutments.....cu. yd.	340	1.00	340	340	1.00	340	340	1.00	340
Backfill abutments.....cu. yd.	120	0.25	30	120	0.25	30	120	0.25	30
Conc. piers.....cu. yd.	37	8.00	300	42	8.00	340	46	8.00	370
Excav. piers.....cu. yd.	70	1.00	70	70	1.00	70	80	1.00	80
Backfill piers.....cu. yd.	40	0.25	10	40	0.25	10	40	0.25	10
Paving right of way...sq. yd.	400	3.25	1,300	490	3.25	1,590	490	3.25	1,590
Sidewalk right of way..sq. ft.	2,400	0.15	360	2,200	0.15	330	3,600	0.15	540
Waterproofing.....sq. ft.	1,725	0.20	340	1,900	0.20	380	2,240	0.20	450
Falswork.....lin. ft.	160	8.00	1,280	172	8.00	1,380	200	8.00	1,600
Eng. and conting's....20%			2,600			2,840			3,140
<b>Total</b> .....			<b>\$15,500</b>			<b>\$17,100</b>			<b>\$18,800</b>
Each additional track costs...			<b>\$5,500</b>			<b>\$6,000</b>			<b>\$6,800</b>

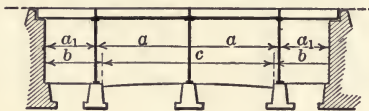

	$a_1$	$a$	$b$	$c$
60 Ft. Street	10.6	19.6	12	36
66 " "	9.6	23.6	11	44
80 " "	16.6	23.6	18	44

TYPE "D" FOUR-SPAN SUBWAY (2 tracks, 13 ft. c'ts).

Material, type D.	60-ft. street.			66-ft. street.			80-ft. street.		
Steel structure.....lb.	121,900	\$0.03	\$3,660	136,400	\$0.03	4,090	162,000	0.03	\$4,860
Conc. floor.....cu. yd.	52	18.00	930	57	18.00	1,030	69	18.00	1,240
Conc. abutments.....cu. yd.	530	7.00	3,710	530	7.00	3,710	530	7.00	3,710
Excav. abutments.....cu. yd.	340	1.00	340	340	1.00	340	340	1.00	340
Backfill abutments.....cu. yd.	120	0.25	30	120	0.25	30	120	0.25	30
Conc. piers.....cu. yd.	45	8.00	360	46	8.00	370	51	8.00	410
Excav. piers.....cu. yd.	80	1.00	80	80	1.00	80	90	1.00	90
Backfill piers.....cu. yd.	40	0.25	10	40	0.25	10	40	0.25	10
Paving right of way...sq. yd.	400	3.25	1,300	490	3.25	1,590	490	3.25	1,590
Sidewalk right of way..sq. ft.	2,400	0.15	360	2,200	0.15	330	3,600	0.15	540
Waterproofing.....sq. ft.	1,725	0.20	340	1,900	0.20	380	2,240	0.20	450
Falswork.....lin. ft.	160	8.00	1,280	172	8.00	1,380	200	8.00	1,600
Eng. and conting's....20%			2,500			2,660			2,930
<b>Total</b> .....			<b>\$14,900</b>			<b>\$16,000</b>			<b>\$17,800</b>
Each additional track costs...			<b>\$5,100</b>			<b>\$5,500</b>			<b>\$6,300</b>



It will be noted by comparing the cost of the various types that the four span subway is the most economical; it is also the most typical as it favors and lends itself to the best type of construction, and at the same time cannot be said to interfere with the general utility of the street as the columns in the center simply divide the traffic which is a convenience in most cases, and those at the curbs separate the vehicle traffic from the foot traffic and is not a detriment. A subway of this kind, which is a very pleasing design, is shown on Fig. 16 as built by the C. M. & St. P. of reinforced concrete and the depth of the floor system is 3' 9" to base of rail; the deep floor enables the structure to be built without any projections above the rail level.

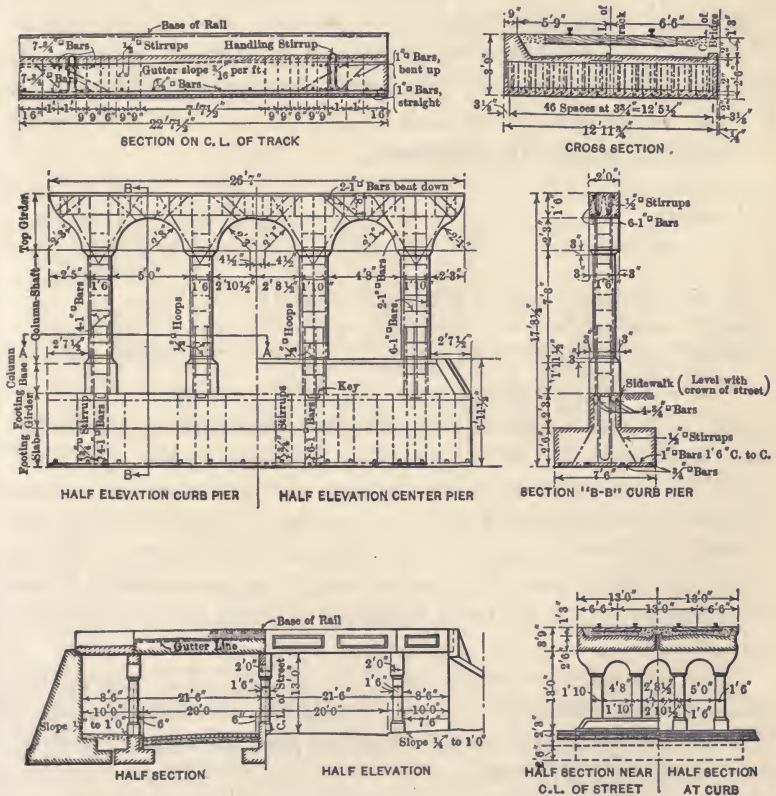

Fig. 16. Reinforced Concrete Subway, C. M. & St. P. Ry.

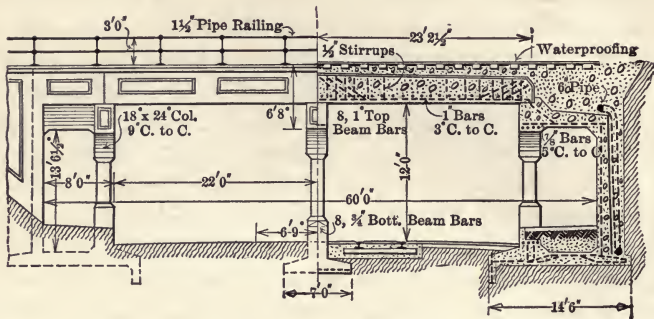

Fig. 17. Typical end elevation and cross section, of Carolina Ave. and Florida St. Subways.

#### Subways. — Memphis, Tenn.

Tracks spaced  $12\frac{1}{2}$  ft. c. to c. Four floor slabs per track, each 6 ft.  $2\frac{1}{2}$  in. by 23 ft.  $2\frac{1}{2}$  in. Designed for Cooper's E 55 loading. Impact, 50 per cent of live load.

#### Quantities per lin. ft. of subway:

Slab floor system.....	4.74 cu. yd.
Abutments.....	4.87 cu. yd.
Center supports.....	0.98 cu. yd.
Total.....	10.59 cu. yd.
Wing walls (right angle 20 ft. long), each	26.81 cu. yd.
Reinforcement of slabs.....	173 lb. per yd.
Reinforcement of substructure.....	140 lb. per yd.
All concrete	1 : 2 : 4.

Fig. 17 shows a typical end elevation and section of the subways at Florida St. and at Carolina Ave. except that the total width between abutments on Carolina Ave. will be 65 ft. The design is especially noteworthy on account of the extensive use of reinforced concrete and of the box type of abutments. Street grades on the subway approaches will be approximately 4 per cent and the paving will be of vitrified brick on a concrete foundation.

These two subways, exclusive of paving but including property damages, will cost approximately \$175,000, of which the city's expense will be approximately \$25,000 plus the cost of paving. *Eng. News*, July 27, 1916.

## CHAPTER VI.

## BRIDGES, TRESTLES, AND CULVERTS.

## Bridge Abutments, Piers, and Retaining Walls.

**Abutments.** — Abutments may be built either of stone or concrete. For the latter, if current is strong, the up-stream corners should be stone-faced. Leave 4-inch clearance between face of ballast wall and end of girders. Frost batter of walls to be finished smooth. Bridge seats to be finished to a dead level throughout on tangents, and on curves given a slope parallel to the super-elevation of the outer rail, including tie seat on the ballast wall.

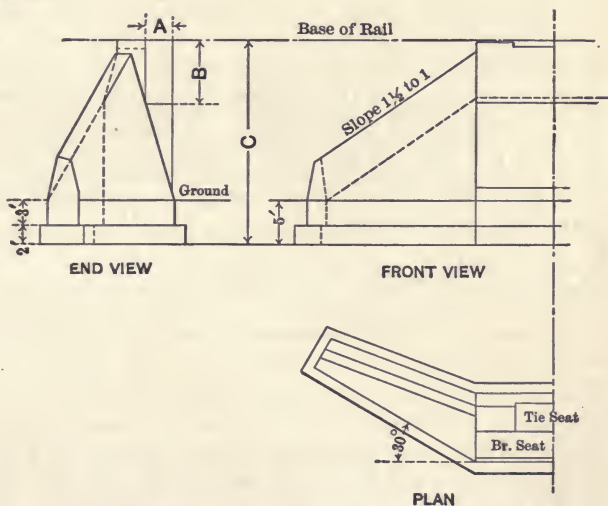

Fig. 18. Bridge Abutments.

On curves locate abutments normal to chord of span. The quantities given in the following tables for bridge abutments include wing walls, based on the assumption that the cross section is level and foundation carried to a depth of 5 ft. below ground line. Wing walls are stopped at a height of 4 feet above ground line.

TABLE 39.—ABUTMENTS FOR DECK PLATE GIRDERS. (Fig. 18.)

Span.	Bridge seats.				Approximate cubic yards in one abutment. Height "C."										
	A.		B.		10 ft.	14 ft.	18 ft.	22 ft.	26 ft.	30 ft.	34 ft.	38 ft.	42 ft.	46 ft.	50 ft.
	Ft.	In.	Ft.	In.											
20	2	0	3	9	28	64	114	180	265	370	498	650	829	1036	1274
30	2	3	4	6	29	66	116	182	267	372	500	652	831	1038	1276
40	2	6	5	6	30	68	118	184	269	374	502	654	833	1040	1278
50	2	9	6	6	31	70	120	186	271	376	504	656	835	1042	1280
60	3	0	8	0	....	72	124	190	275	380	508	660	839	1046	1284
70	3	3	9	0	....	74	128	195	279	384	512	664	843	1050	1289
80	3	6	10	0	....	75	130	198	283	388	516	668	847	1054	1293
90	4	0	10	6	....	76	133	203	288	393	520	673	852	1059	1297

TABLE 40.—ABUTMENTS FOR HALF DECK GIRDERS. (Fig. 18.)

Span.	Bridge seats.				Approximate cubic yards in one abutment. Height "C."										
	A.		B.		10 ft.	14 ft.	18 ft.	22 ft.	26 ft.	30 ft.	34 ft.	38 ft.	42 ft.	46 ft.	50 ft.
	Ft.	In.	Ft.	In.											
20	2	0	1	8	27	63	113	179	264	369	497	649	828	1035	1273
30	2	3	1	8	28	65	115	181	266	371	499	651	829	1037	1275
40	2	6	1	8	29	66	116	182	267	372	500	652	830	1038	1276
50	2	9	2	5	29	67	117	183	268	373	501	654	832	1040	1278
60	3	0	3	11	30	70	121	187	272	377	505	658	835	1043	1281
70	3	3	4	10	31	72	124	191	276	381	509	663	840	1048	1286
80	3	6	5	9	32	74	127	195	280	384	512	666	843	1051	1289

TABLE 41.—ABUTMENTS FOR THROUGH BRIDGES. (Fig. 18.)

Span.	Bridge seats.				Approximate cubic yards in one abutment. Height "C."										
	A.		B.		10 ft.	14 ft.	18 ft.	22 ft.	26 ft.	30 ft.	34 ft.	38 ft.	42 ft.	46 ft.	50 ft.
	Ft.	In.	Ft.	In.											
100	4	0	5	6	38	84	139	208	294	398	526	680	857	965	1303
125	4	0	5	9	39	85	140	210	296	400	528	682	859	967	1305
150	4	0	5	9	39	85	141	211	298	402	530	684	861	969	1307
200	4	6	6	0	40	86	143	213	301	405	533	687	865	973	1311

**Bridge Piers.** — Piers may be built either of concrete or stone. If of concrete, the up-stream cutwater exposed to the action of swift currents, ice, or driftwood should have stone facing, to about 3 feet above high water.

When it is necessary to carry abutments or piers on piles, a grillage of 12"  $\times$  12" timbers embedded in concrete is very commonly used to form a base over the piles as shown in Fig. 19.

The piles and timbers are placed about 3-foot centers, and the quantities per square foot of area covered (D.  $\times$  E.) would be approximately as follows:

Number of piles.....	0.12 $\times$ D. E.
Cubic yards concrete.....	0.06 $\times$ D. E.
Ft. B. M. timber.....	8.0 $\times$ D. E.

Estimate for concrete base and pile foundation from above data:  
Piles 20 feet long, D. 9 feet and E. 18 feet = 162 square feet.

No. of piles 162 $\times$ 0.12 = 19 $\times$ 20 = 380 ft. at 25 cts.....	\$95.00
Ft. B. M. 12 $\times$ 12 timbers 162 $\times$ 8 = 1296 ft. B. M. at \$30..	38.88
Cu. yd. concrete, 162 $\times$ 0.06 = 9.7 cu. yd. at \$8.....	77.60
Total.....	<u>\$201.48</u>

In addition to the concrete base it is usually necessary to place caissons or wood cribs around the piers, forming a watertight box from which the water is pumped so that the foundations can be laid dry. These boxes are made up of 12"  $\times$  12" timbers framed and braced, or sheet piling, either wood or steel, is often used. The cost and quantities vary with the nature of foundation and are usually paid for at unit prices.

In place of the concrete and timber base sometimes a solid floor 24 inches thick made up of 12"  $\times$  12" timbers drift-bolted together is used as a floating platform on which the masonry is built, and sunk into position over the piles, the piles having previously been cut off by an under-water saw.

The objection to this method is the liability in case of an ice shove for the pier to slide between the platform and piles.

All piers and abutments should be sufficiently protected from scour, which is one of the chief sources of bridge failures. This can only be done by taking foundations down to solid bottom and anchoring the masonry to the foundation bed by large stone bolts, or dowels.

In running water they should be further protected by stone riprapping all around; and when the clearance is limited and severe ice shoves are likely to occur, crib protection piers filled with stones, placed 25 to 50 feet ahead of each pier up stream, should be used.

## QUANTITIES IN BRIDGE PIERS.

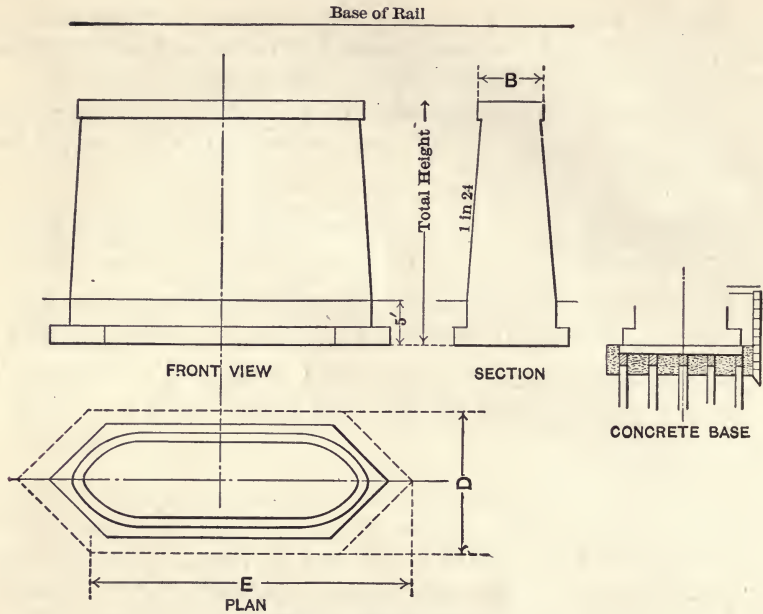

Fig. 19. Bridge Piers.

TABLE 42. — APPROXIMATE CUBIC YARDS IN ONE PIER. (Fig. 19.)

Width of piers. " B."	(For girders 13-foot centers or less.) Total height.												
	10 ft.	14 ft.	18 ft.	22 ft.	26 ft.	30 ft.	34 ft.	38 ft.	42 ft.	46 ft.	50 ft.	54 ft.	58 ft.
Ft. In.													
4 0	39	56	74	93	114	137	161	186	214	243	274	306	340
4 6	45	64	84	105	129	155	180	208	238	269	304	338	376
5 0	50	71	93	118	143	171	200	231	263	298	334	371	412
5 6	56	79	104	131	159	189	220	254	289	326	365	406	449
6 0	62	88	115	144	175	207	242	278	317	358	399	443	489
6 6	68	96	126	158	191	227	264	303	344	387	433	480	529
7 0	75	106	138	172	209	247	287	329	373	420	467	518	570
7 6	81	115	150	187	226	267	310	355	403	454	504	558	614
8 0	88	124	165	203	245	289	335	383	434	486	541	598	657

TABLE 43. — APPROXIMATE CUBIC YARDS IN ONE PIER. (Fig. 19.)

Width of piers. " B."	(For girders over 13-foot centers up to 20-foot centers.) Total height.												
	10 ft.	14 ft.	18 ft.	22 ft.	26 ft.	30 ft.	34 ft.	38 ft.	42 ft.	46 ft.	50 ft.	54 ft.	58 ft.
Ft. In.													
6 0	83	117	152	190	231	273	318	364	415	467	520	576	635
6 6	90	127	166	208	251	297	345	395	448	503	561	621	683
7 0	98	139	181	225	272	321	373	427	483	543	603	667	733
7 6	106	150	195	243	293	346	401	458	519	583	647	715	786
8 0	114	161	211	262	316	372	431	492	557	622	692	764	837
8 6	123	174	227	281	339	399	461	528	595	664	738	812	891
9 0	132	186	241	301	362	426	492	562	632	707	783	861	941

TABLE 44. — BRIDGE PIERS WITH OR WITHOUT CUTWATERS FOR DECK PLATE GIRDERS.

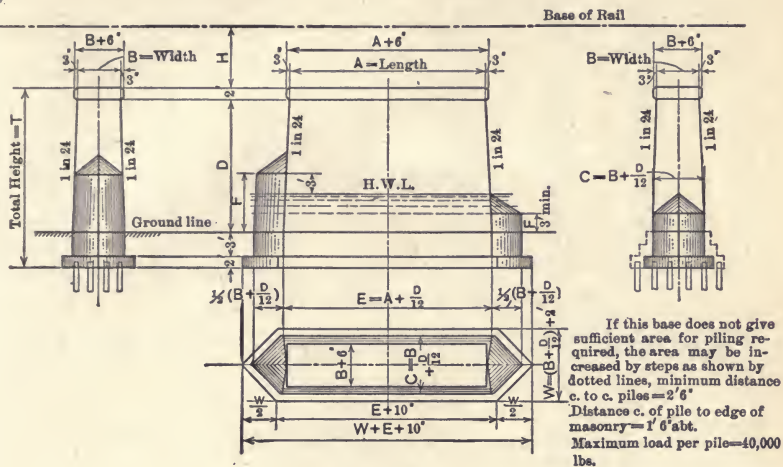

Fig. 19a.

QUANTITIES, CUBIC YARDS IN ONE PIER WITHOUT CUTWATERS FOR D. P. G. SPANS,  $A = 16' 0''$ .

T.	Width B.						
	4' 0"	5' 0"	6' 0"	7' 0"	8' 0"	9' 0"	10' 0"
12	35	43	50	58	65	72	80
14	41	50	58	67	76	84	93
16	47	57	67	77	87	97	107
18	54	65	77	88	99	111	122
20	61	74	86	99	111	124	137
22	68	82	96	110	124	138	152
24	76	91	107	122	137	153	168
26	84	100	117	133	150	167	184
28	92	110	128	146	163	181	200
30	101	120	139	159	178	197	216
32	110	131	151	172	193	213	233
34	119	141	163	185	207	229	251
36	128	152	175	199	223	246	269
38	138	163	188	213	238	263	287
40	148	175	201	227	253	279	305
42	158	186	214	242	269	297	324
44	169	198	228	257	286	315	344
46	180	211	242	273	303	334	364
48	191	223	255	287	320	352	384
50	203	237	270	304	338	372	405
52	215	251	286	321	356	391	426
54	228	265	301	338	374	411	447
56	241	279	317	355	393	431	469
58	254	294	333	373	412	452	491
60	268	309	349	390	431	472	513

## QUANTITIES, CUBIC YARDS IN ONE CUTWATER.

F.	Width C.						
	4' 0"	5' 0"	6' 0"	7' 0"	8' 0"	9' 0"	10' 0"
3	1.60	2.35	3.30	4.5	5.8	7.3	9.0
6	1.80	2.80	3.90	5.3	6.9	8.7	10.7
7	2.00	3.15	4.45	6.0	7.9	10.0	12.3
9	2.20	3.50	5.00	6.7	8.9	11.2	13.9
11	2.40	3.80	5.45	7.4	9.8	12.4	15.4
13	2.55	4.10	5.90	8.0	10.6	13.5	16.9
15	2.70	4.35	6.30	8.6	11.4	14.6	18.3
17	2.85	4.60	6.70	9.2	12.2	15.7	19.6
19	2.95	4.80	7.10	9.8	13.0	16.7	20.9
21	3.05	5.00	7.40	10.4	13.7	17.7	22.1
23	3.10	5.15	7.70	10.9	14.4	18.6	23.3
25	3.13	5.30	8.00	11.3	15.0	19.5	24.4
27	3.16	5.40	8.30	11.7	15.6	20.3	25.5
29	3.19	5.50	8.50	12.1	16.2	21.0	26.6
31	3.21	5.60	8.60	12.5	16.7	21.7	27.6
33	3.22	5.70	8.70	12.8	17.2	22.3	28.5

*Method of Finding Total Quantity Cubic Yards in Pier.*

To find quantities in a pier where length  $A = 16' 0''$ , width  $B = 6' 0''$  and total height  $T = 40' 0''$ , when depth of high water =  $20' 0''$

$$C = 6' + \frac{40 - 7}{12} = 8' 9'', \text{ and } F = 20' + 3' = 23' 0''.$$

From Table. —

Quantity in pier without cutwater = 201 cu. yd.

In upstream cutwater where  $F = 23'$ ,  $C = 9'$ , quantity = 18.6 cu. yd.

In upstream cutwater where  $F = 23'$ ,  $C = 8'$ , quantity =  $\frac{14.4}{4.2}$

$$\text{Interpolating, quantity in desired cutwater} = 18.6 - \frac{4.2}{12} \times 3 = 17.55$$

Similarly, quantity for downstream cutwater where  $F = 3'$  and  $C = 8' 9'' = \frac{6.95}{12}$

Total quantity in pier 225.50



TABLE 45. — BRIDGE PIERS WITH OR WITHOUT CUTWATERS FOR HALF DECK PLATE GIRDERS.

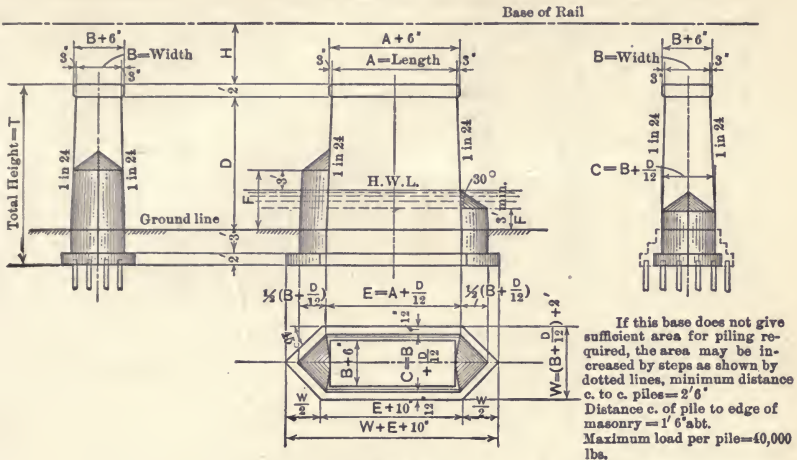

Fig. 19b.

QUANTITIES, CUBIC YARDS IN ONE PIER WITHOUT CUTWATERS FOR H. D. P. G. SPANS. A = 18' 0".

T.	Width B.						
	4' 0"	5' 0"	6' 0"	7' 0"	8' 0"	9' 0"	10' 0"
12	39	48	56	64	72	81	89
14	46	56	66	75	85	95	104
16	53	64	75	87	97	109	120
18	61	74	86	98	111	123	136
20	69	83	97	111	124	138	152
22	77	93	108	123	139	155	170
24	86	102	120	136	153	170	187
26	95	113	132	150	169	187	205
28	104	124	144	163	183	203	223
30	113	134	156	177	198	220	241
32	123	146	169	191	214	237	260
34	133	157	181	206	230	254	279
36	143	169	195	221	247	273	298
38	153	181	208	236	263	291	318
40	164	193	222	251	280	309	338
42	176	206	237	267	298	329	359
44	188	220	252	284	316	348	380
46	200	234	268	301	335	368	402
48	212	247	283	318	353	389	424
50	225	262	299	336	373	410	447
52	238	277	316	354	393	432	470
54	252	292	333	373	413	453	494
56	266	308	350	392	434	476	518
58	280	324	368	411	455	499	542
60	295	340	386	431	476	522	567

## QUANTITIES, CUBIC YARDS IN ONE CUTWATER.

F.	Width C.						
	4' 0''	5' 0''	6' 0''	7' 0''	8' 0''	9' 0''	10' 0''
3	1.60	2.35	3.30	4.5	5.8	7.3	9.0
6	1.80	2.80	3.90	5.3	6.9	8.7	10.7
7	2.00	3.15	4.45	6.0	7.9	10.0	12.3
9	2.20	3.50	5.00	6.7	8.9	11.2	13.9
11	2.40	3.80	5.45	7.4	9.8	12.4	15.4
13	2.55	4.10	5.90	8.0	10.6	13.5	16.9
15	2.70	4.35	6.30	8.6	11.4	14.6	18.3
17	2.85	4.60	6.70	9.2	12.2	15.7	19.6
19	2.95	4.80	7.10	9.8	13.0	16.7	20.9
21	3.05	5.00	7.40	10.4	13.7	17.7	22.1
23	3.10	5.15	7.70	10.9	14.4	18.6	23.3
25	3.13	5.30	8.00	11.3	15.0	19.5	24.4
27	3.16	5.40	8.30	11.7	15.6	20.3	25.5
29	3.19	5.50	8.50	12.1	16.2	21.0	26.6
31	3.21	5.60	8.60	12.5	16.7	21.7	27.6
33	3.22	5.70	8.70	12.8	17.2	22.3	28.5

*Method of Finding Total Quantity Cubic Yards in Pier.*

To find quantities in a pier where length  $A = 18' 0''$ , width  $B = 6' 0''$  and total height  $T = 40' 0''$ , when depth of high water =  $20' 0''$

$$C = 6' + \frac{40 - 7}{12} = 8' 9'', \text{ and } F = 20' + 3' = 23' 0''.$$

From Table. —

Quantity in pier without cutwater = 222 cu. yd.

In upstream cutwater where  $F = 23'$ ,  $C = 9'$ , quantity = 18.6 cu. yds.

In upstream cutwater where  $F = 23'$ ,  $C = 8'$ , quantity =  $\frac{14.4}{4.2}$

$$\text{Interpolating, quantity in desired cutwater} = 18.6 - \frac{4.2}{12} \times 3 = 17.55$$

Similarly, quantity for downstream cutwater where  $F = 3'$  and  $C = 8' 9'' = \frac{6.95}{246.50}$

TABLE 46. — BRIDGE PIERS WITH OR WITHOUT CUTWATERS FOR THROUGH TRUSS SPANS.

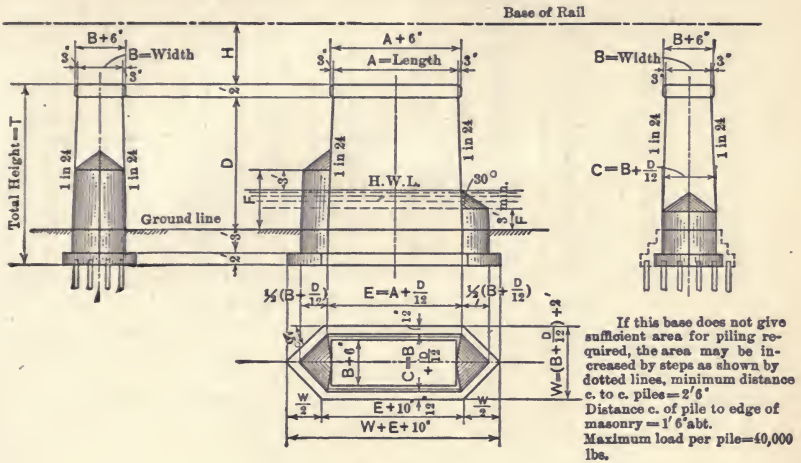

Fig. 19c.

QUANTITIES, CUBIC YARDS IN ONE PIER WITHOUT CUTWATERS THROUGH TRUSS SPANS.  
A = 25' 0".

T.	Width B.						
	6' 0"	7' 0"	8' 0"	9' 0"	10' 0"	11' 0"	12' 0"
12	76	88	99	111	122	133	145
14	89	103	116	129	143	156	169
16	103	119	134	149	164	179	194
18	117	134	152	169	186	204	220
20	132	151	170	189	208	227	246
22	147	168	189	210	231	252	273
24	162	185	208	231	254	277	300
26	178	203	228	253	278	303	328
28	194	222	249	276	303	330	356
30	211	240	269	298	328	357	385
32	228	259	291	321	353	383	414
34	246	279	312	345	378	411	444
36	264	299	334	369	404	439	474
38	283	320	357	394	431	468	505
40	302	341	380	419	458	497	536
42	321	362	403	445	486	527	568
44	341	384	428	471	514	557	600
46	361	407	452	497	543	588	633
48	382	430	477	525	572	620	667
50	403	453	503	553	603	653	703
52	425	477	529	581	634	686	738
54	447	502	556	611	665	720	774
56	470	526	583	640	697	754	810
58	493	552	611	670	728	787	846
60	517	578	638	699	760	821	882

## QUANTITIES IN BRIDGE PIERS.

QUANTITIES, CUBIC YARDS IN ONE CUTWATER.

F.	Width C.									
	4' 0''	5' 0''	6' 0''	7' 0''	8' 0''	9' 0''	10' 0''	11' 0''	12' 0''	
3	1.60	2.35	3.30	4.5	5.8	7.3	9.0	10.9	13.0	
6	1.80	2.80	3.90	5.3	6.9	8.7	10.7	12.9	15.5	
7	2.00	3.15	4.45	6.0	7.9	10.0	12.3	14.9	17.9	
9	2.20	3.50	5.00	6.7	8.9	11.2	13.9	16.8	20.2	
11	2.40	3.80	5.45	7.4	9.8	12.4	15.4	18.7	22.4	
13	2.55	4.10	5.90	8.0	10.6	13.5	16.9	20.5	24.5	
15	2.70	4.35	6.30	8.6	11.4	14.6	18.3	22.2	26.6	
17	2.85	4.60	6.70	9.2	12.2	15.7	19.6	23.9	28.7	
19	2.95	4.80	7.10	9.8	13.0	16.7	20.9	25.6	30.7	
21	3.05	5.00	7.40	10.4	13.7	17.7	22.1	27.2	32.7	
23	3.10	5.15	7.70	10.9	14.4	18.6	23.3	28.7	34.5	
25	3.13	5.30	8.00	11.3	15.0	19.5	24.4	30.1	36.4	
27	3.16	5.40	8.30	11.7	15.6	20.3	25.5	31.5	38.1	
29	3.19	5.50	8.50	12.1	16.2	21.0	26.6	32.8	39.8	
31	3.21	5.60	8.60	12.5	16.7	21.7	27.6	34.1	41.4	
33	3.22	5.70	8.70	12.8	17.2	22.3	28.5	35.3	43.0	

*Method of Finding Total Quantity Cubic Yards in Pier.*

To find quantities in a pier where length  $A = 25' 0''$ , width  $B 8' 0''$  and total height  $T = 40' 0''$ , when depth of high water =  $20' 0''$ .

$$C = 8' + \frac{40 - 7}{12} = 10' 9'', \text{ and } F = 20' + 3' = 23' 0''.$$

From Table. —

Quantity in pier without cutwater = 380.00 cu. yd.

In upstream cutwater where  $F = 23'$ ,  $C = 11'$ , quantity = 28.7 cu. yd.In upstream cutwater where  $F = 23'$ ,  $C = 10'$ , quantity = 23.3 cu. yd.

5.4

Interpolating, quantity in desired cutwater =  $28.7 - \frac{5.4}{12} \times 3 = 27.40$  cu. yd.Similarly, quantity for downstream cutwater where  $F = 3'$  and  $C = 10' 9'' = 10.40$  cu. yd.

Total quantity in pier 417.80 cu. yd.

TABLE 47. — BRIDGE PIERS WITH OR WITHOUT CUTWATERS FOR THROUGH PLATE GIRDERS.

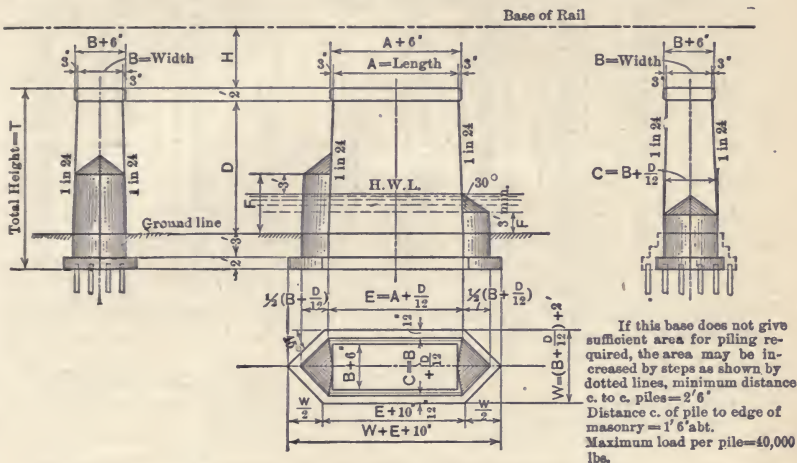

Fig. 19d.

QUANTITIES, CUBIC YARDS IN ONE PIER WITHOUT CUTWATERS FOR 100 FT. THROUGH P. G. SPANS. A = 24' 0".

T.	Width B.						
	6' 0"	7' 0"	8' 0"	9' 0"	10' 0"	11' 0"	12' 0"
12	74	85	96	107	118	129	139
14	86	99	112	125	137	150	163
16	99	114	129	144	159	173	188
18	113	130	147	163	180	197	213
20	127	146	164	183	201	220	238
22	141	162	182	203	223	244	264
24	156	179	201	223	245	268	290
26	171	196	220	244	268	292	317
28	187	214	240	266	292	318	344
30	203	231	259	287	315	343	372
32	220	250	280	310	340	370	400
34	237	269	301	333	365	397	429
36	254	288	322	356	390	424	458
38	272	308	344	380	416	452	488
40	290	328	366	404	442	480	518
42	309	349	389	429	469	509	549
44	328	370	412	454	496	538	580
46	348	392	436	480	524	568	612
48	368	414	460	506	552	598	644
50	388	436	484	533	581	629	677
52	409	460	510	560	611	661	711
54	430	483	536	588	641	693	745
56	452	507	562	617	671	725	780
58	475	532	588	645	702	758	815
60	498	556	615	674	732	791	850

## QUANTITIES IN BRIDGE PIERS.

## QUANTITIES, CUBIC YARDS IN ONE CUTWATER.

F.	Width C.								
	4' 0"	5' 0"	6' 0"	7' 0"	8' 0"	9' 0"	10' 0"	11' 0"	12' 0"
3	1.60	2.35	3.30	4.5	5.8	7.3	9.0	10.9	13.0
6	1.80	2.80	3.90	5.3	6.9	8.7	10.7	12.9	15.5
7	2.00	3.15	4.45	6.0	7.9	10.0	12.3	14.9	17.9
9	2.20	3.50	5.00	6.7	8.9	11.2	13.9	16.8	20.2
11	2.40	3.80	5.45	7.4	9.8	12.4	15.4	18.7	22.4
13	2.55	4.10	5.90	8.0	10.6	13.5	16.9	20.5	24.5
15	2.70	4.35	6.30	8.6	11.4	14.6	18.3	22.2	26.6
17	2.85	4.60	6.70	9.2	12.2	15.7	19.6	23.9	28.7
19	2.95	4.80	7.10	9.8	13.0	16.7	20.9	25.6	30.7
21	3.05	5.00	7.40	10.4	13.7	17.7	22.1	27.2	32.7
23	3.10	5.15	7.70	10.9	14.4	18.6	23.3	28.7	34.6
25	3.13	5.30	8.00	11.3	15.0	19.5	24.4	30.1	36.4
27	3.16	5.40	8.30	11.7	15.6	20.3	25.5	31.5	38.1
29	3.19	5.50	8.50	12.1	16.2	21.0	26.6	32.8	39.8
31	3.21	5.60	8.60	12.5	16.7	21.7	27.6	34.1	41.4
33	3.22	5.70	8.70	12.8	17.2	22.3	28.5	35.3	43.0

*Method of Finding Total Quantity Cubic Yards in Pier.*

To find quantities in a pier where length  $A = 24$  0'', width  $B$  8' 0'' and total height  $T = 40$  0'', when depth of high water = 20' 0''.

$$C = 8' + \frac{40 - 7}{12} = 10' 9'', \text{ and } F = 20' + 3' = 23' 0''.$$

From Table. —

Quantity in pier without cutwater = 366.00 cu. yd.

In upstream cutwater where  $F = 23'$ ,  $C = 11'$ , quantity = 23.7 cu. yd.

In upstream cutwater where  $F = 23'$ ,  $C = 10'$ , quantity = 23.3 cu. yd.

5.4 cu. yd.

Interpolating, quantity in desired cutwater =  $23.7 - \frac{5.4}{12} \times 3 = 27.40$  cu. yd.

Similarly, quantity for downstream cutwater where  $F = 3'$  and  $C = 10' 9'' = \frac{10.40}{12}$  cu. yd.

Total quantity in pier  $\frac{403.80}{12}$  cu. yd.

**Retaining Walls.** — A narrow right of way and high property values or encroachments on public highways will usually necessitate the building of retaining walls.

A gravity or semi-gravity wall is economical up to 16 or 18 feet; above 18 feet it is considered that a reinforced wall is the cheaper one; the type of wall to adopt however will chiefly be governed by conditions; for example on the grade separation work at McKees Rock, Pa. (Penna Lines West), the retaining walls were 20 feet high and mass walls were built, as the conditions made it more economical than a reinforced wall. A reinforced wall with a long foundation toe would have necessitated the abandoning or shifting of the operating track with considerable interference to traffic and would have meant the building of one wall at a time. For a straight gravity wall the base is generally about  $\frac{1}{5}$  the height, for railway construction work, and a typical wall of this kind is given on page 35 with quantities in cubic yards for each foot in height and also per foot run for various heights of wall.

For example it is desired to ascertain the number of cubic yards per lineal foot in a gravity wall 25 feet high.

In the column of heights at 25 feet the cubic yards per lineal foot is given as 7.172 and the width of base for this height 11' 6 $\frac{1}{2}$ ".

A reinforced concrete retaining wall for vehicle traffic with quantities for varying heights is given on page 36.

**Cost of Retaining Walls.** — The unit prices for this class of work has a very wide variation depending upon location, quantity, facilities at hand, etc.; the following unit prices however are fair average figures for work of this character and will be used in estimating the various types of walls mentioned and is for the work built in place.

Excavation, per cu. yd. . . . .	\$1.00	Steel, reinforced, per lb. . . . .	\$0.03
Back fill, per cu. yd. . . . .	0.50	Piles, concrete, per ft. . . . .	1.30
Concrete, plain, per cu. yd. . . . .	8.00	Piles, wood, per ft. . . . .	0.40
Concrete, reinforced, per cu. yd. . . . .	10.00	Waterproofing walls, sq. yd. . . . .	0.25
Fill, reinforced, per cu. yd. . . . .	0.40	Waterproofing floor slabs, sq. yd. . . . .	1.80

**Retaining Walls, Chicago Track Elevation.** — In the Chicago Track Elevation (Rock Island Lines) the retaining walls are built in alternate blocks of 35 feet, with traveling forms. It takes about six hours to fill the form, which is then left in place about fifteen hours. In about twenty hours the traveling form is released and moved seventy feet forward and is then ready for the next section.

It is stated that the use of the traveling forms has enabled the work to be done in about 25 per cent of the time required with ordinary forms (from the building to the removal of the form) and at about 50 per cent of the cost (including erecting, pouring and dismantling) their general construction and approximate estimate of cost, using the unit prices already referred to, follows:

**Foundations.** — Concrete piles cast in place in clay soil, average length 22 ft. Load 20 to 25 tons per pile.

**Walls and Footings.** — Mixture, 1 : 3 : 5, built in 35 ft. lg. sections, varying from 20 to 36 ft. in height. Fig. 19c shows vertical face practically on right of way line, with footings projecting under sidewalk. Fig. 19g shows footing on right of way line but full width of roadway is retained by projecting wall at top on supporting brackets.

Comparative figures and quantities for both types of wall on the same unit basis are given on page 97.

**Conduits.** — Six duct conduits near top of wall for electric wires, cables and telegraph lines with manhole chambers 400 ft. apart, size 6 ft.  $\times$  3 ft.  $\times$  4 ft. deep with reinforced concrete slab over manhole and 28 in. iron cover.

**Drainage.** — Wells are provided in the ends of retaining walls adjacent to subway abutments 3 ft.  $\times$  3 ft. extending to bottom of wall. No weep holes are provided, but along the back of walls are laid inclined drains of porous tile, on a grade of 0.5 per cent extending from subgrade level to 6'' pipes which discharge into the drainage well. Each well has an 8'' connection to sewer.

**Water-proofing.** — Tar pitch composition applied to back of wall, a strip of burlap and felt being placed over each expansion joint, well mopped with the composition.

**Fill.** — Sand and gravel, dumped from cars. Before final surfacing to subgrade, fill will be thoroughly soaked with water, to reduce settlement to a minimum.



TYPICAL RETAINING WALLS  
CHICAGO TRACK ELEVATION

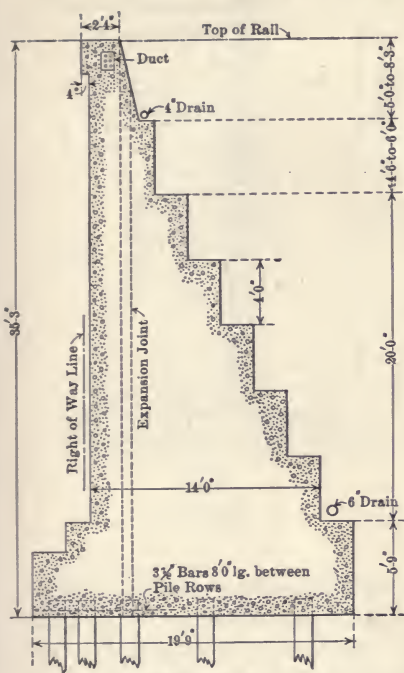

SECTION (A)

Fig. 19e.

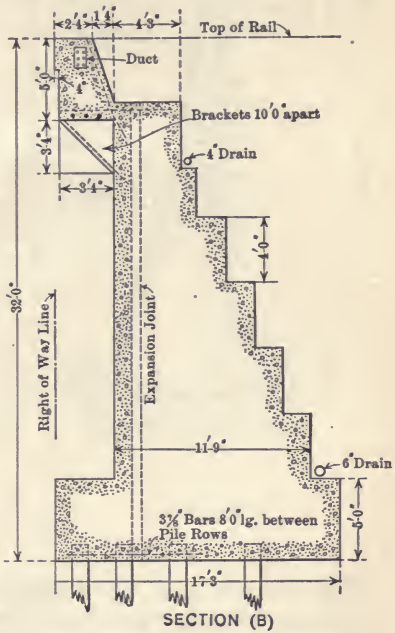

SECTION (B)

Fig. 19g.

TABLE 48.—APPROXIMATE ESTIMATE OF COST PER LINEAL FOOT OF WALL.

Items.	Section A. Gravity wall (35 ft. 3 in. high).			Section B. Gravity wall (32 feet high).		
Excavation.....	6 cu. yds.	\$1.00	\$6.00	6 cu. yds.	\$1.00	\$6.00
Back fill.....	3 cu. yds.	0.50	1.50	3 cu. yds.	0.50	1.50
Piles (concrete).....	35 lin. ft.	1.30	45.50	30 lin. ft.	1.30	39.00
Drainage.....	.....	.....	1.00	.....	.....	1.00
Concrete (plain).....	12.7 cu. yds.	8.00	101.60	10.5 cu. yds.	8.00	84.00
Steel reinforcement..	25 lbs.	0.03	0.75	45 lbs.	0.03	1.35
Conduit for wires....	.....	.....	2.00	.....	.....	2.00
Waterproofing.....	4 sq. yds.	0.25	1.00	4 sq. yds.	0.25	1.00
Supervision.....	.....	.....	15.65	.....	.....	14.15
Total cost per lineal foot of wall	.....	.....	\$175.00	.....	.....	\$150.00

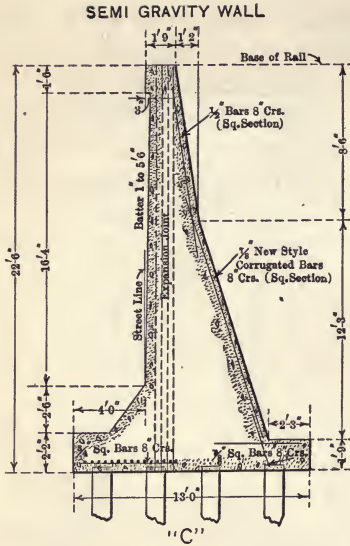

Fig. 19h.

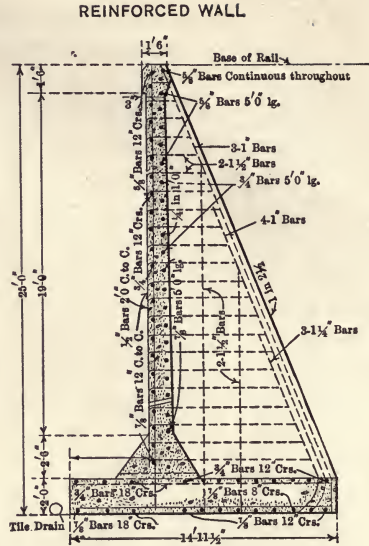

Fig. 19j.

Figures 19h and 19j illustrate a semi-gravity and a straight reinforced retaining wall used in grade separation work. The semi-gravity wall was built 22 ft. 6 in. high with pile foundation, the reinforced wall 25 ft. high on ground that did not require piling. The figures given are from the bottom of footing to top of wall in each case.

TABLE 49.—APPROXIMATE ESTIMATE OF COST PER LINEAL FOOT OF WALL.

Items.	Section C. Semi-gravity wall (22 in. 6 ft. high).		Section D. Reinforced wall (25 ft. high).	
Excavation.....	3 cu. yds.	\$1.00 \$ 3.00	3 cu. yds.	\$1.00 \$ 3.00
Back fill.....	1½ cu. yds.	0.50 0.75	1½ cu. yds.	0.50 0.75
Piles (wood).....	30 lin. ft.	0.40 12.00	30 lin. ft.	0.40 12.00
Drainage.....	Per lin. ft.	..... 1.00	Per lin. ft.	..... 1.00
Concrete, plain.....	3.8 cu. yds.	8.00 30.40	2.8 cu. yds.	10.00 28.00
Steel reinforcement..	250 lbs.	0.03 7.50	300 lbs.	0.03 9.00
Waterproofing.....	3 sq. yds.	0.25 0.75	3 sq. yds.	0.25 0.75
Supervision.....	10% (about)	..... 5.60	10% (about)	..... 5.50
Total cost per lineal foot of wall..	.....	\$61.00	.....	\$60.00

**Crib Work.** — For cheap first cost or temporary construction across or alongside water fronts or embankments, or for abutments, piers, dams, retaining walls, wharves, etc., wooden cribs are used extensively. Figs. 20, 21, and 22.

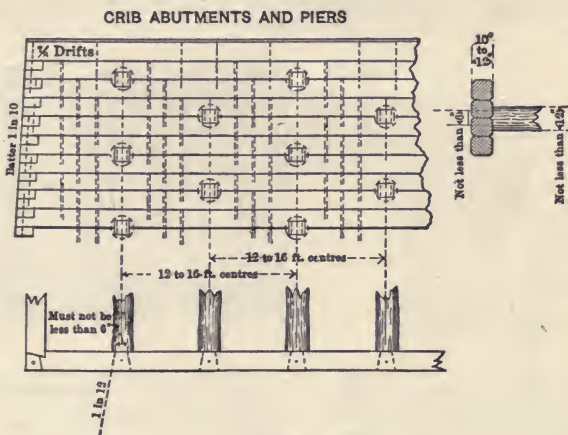

Fig. 20.

The bottoms of the cribs are constructed to suit the irregularities or unevenness of the ground, any deposit or obstruction in the bottom being removed so that a section when sunk in place will take an even bearing throughout; when filled with ballast the top of the crib should be reasonably straight and in good alignment. Sometimes the portion under low water level is built of several cribs, piles being driven on the outer line of the work against which the cribs may be floated and sunk, the guide piles being cut off below low water after the work is completed.

**Construction.** — The timbers are usually cedar under water and tamarac above with bark removed; the outer timbers are hewn or sawn perfectly true and parallel on two opposite sides to a face of at least 9 inches, and from 10 to 12 inches thick, the joints made as close as possible without dressing and so laid as to break joint; all cross ties are dovetailed; notches are cut in the face timbers to receive the dovetails, one-half into the course above and one-half into the course below; timbers at the angles are halved and carefully dovetailed. All timbers held by drift

bolts  $\frac{7}{8}$  inch in diameter, equal to a depth of not less than  $3\frac{1}{2}$  courses; sometimes tree nails of oak or rock-elm are used in place of drifts.

**Log Cribs.** — The cross and longitudinal ties may be round logs long enough to pass completely through the crib from side

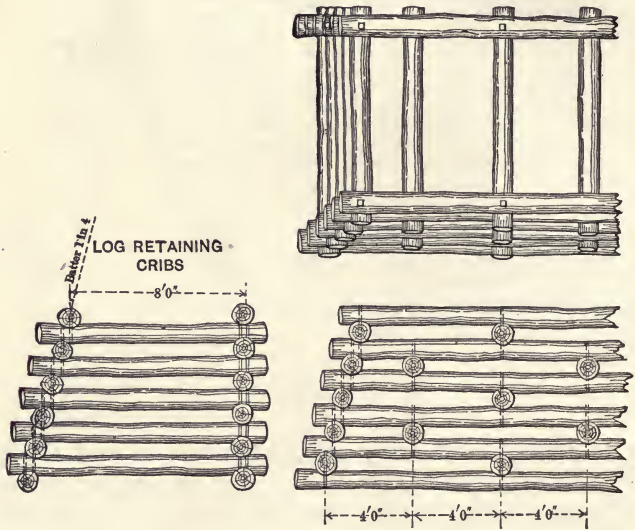

Fig. 21.

to side; when they intersect they are boxed down on each other and bolted.

A close floor of cedar spars, not less than 8 inches in diameter, is laid on the first tier of cross ties to hold the ballast, or stone filling; sometimes the floor is laid solid crosswise of the crib and resting on bottom longitudinal face courses.

APPROXIMATE COST OF CRIBBING IN PLACE.

Squared timbers, per thousand feet board measure.....	\$30.00 to \$50.00
Round cedar timbers, per foot.....	.12 to .20
Iron in crib, per pound.....	.04 to .06
Filling (stone or ballast), per cubic yard.....	.25 to 1.50
Leveling off and clearing (dry), per cubic yard.....	.20 to .30
Leveling off and clearing (wet).....	.50 to 1.00

**Crib Abutments.** (Fig. 22.) — For permanent structures on high fill embankments timber crib abutments are sometimes placed, when the cost of masonry to solid ground would be excessive and out of proportion to the balance of the structure. After a number of years, when the bank is solidified, the crib may be removed and a masonry abutment placed in the usual way.

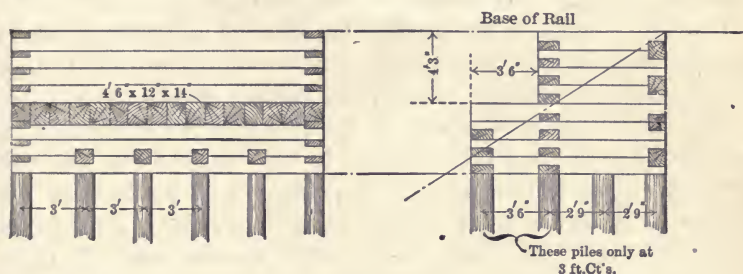

Fig. 22.

## APPROXIMATE COST OF ONE CRIB ABUTMENT.

5000 feet board measure timber at \$30 .....	\$150.00
16 piles 30 feet long each = 480 feet at 20 cts.....	96.00
500 pounds iron in above at 5 cts.....	25.00
Back filling, etc.....	29.00
Total.....	\$300.00

The wooden abutments illustrated above are built of 12 in. by 12 in. timbers dovetailed at the ends, with cross ties about 3 ft. centers on the lower portion of the crib only. The floor or bridge seat is made solid with 12 in. by 14 in. timbers. All timbers are drift bolted with  $\frac{7}{8}$  in. round spikes. The piles are 10 to 12 in. diameter at about 3 ft. centers. The crib after completion is filled with stone or good coarse gravel ballast.

## RAILWAY BRIDGES.

**Deck Plate Girders.** (Fig. 23.) — Deck plate bridges are made of steel plates and angles, fabricated and riveted up into girders, etc., in the shops.

The girders are placed at 9 feet centers more or less, and are held laterally by steel brace frames at varying intervals placed crosswise, and by longitudinal bracing top and bottom.

Usually the span is completely shop-riveted and shipped ready to drop into place, so that it is only necessary to insert the stone bolts and erect the floor, which is very easily done.

The ends of girders resting on the masonry are supported on steel bearing and bed plates bolted to the bridge seats; the bolt holes are slotted to allow for expansion and contraction for bridges up to 50 feet span, and for bridges over this limit, bearing and pin-centered bed plates with steel rollers are generally used.

Generally speaking, though not the cheapest type of bridge to use, it is the most convenient when ample clearance can be had.

Approximate weight and cost of Deck Plate Girder Spans from 20 to 100 feet are given in Table 50.

**Half Deck Plate Girders.** (Fig. 24.) — Half deck plate bridges are fabricated in the same manner, but the girders, frame and bracings are shipped loose and field riveted to the girders when placed. The girders are widened out to allow train clearance between, as the floor is placed below the top flanges of the bridge; the brace frames being somewhat shallow are reinforced by gusset plates, which extend from the top to the bottom flanges in triangular form.

The floor system, on account of the longer distance between girders, is very much heavier than the deck floor; in many cases it is built of steel and reinforced concrete, with ties embedded in ballast.

This type of bridge is convenient, and used to a large extent where the bridge clearance is limited. The wood floor between girders is the cheapest, but steel floor beams and stringers is better construction.

Approximate weight and cost of Half Deck Plate Girder Spans from 20 to 80 feet are given in Table 51 (wood floor between girders).

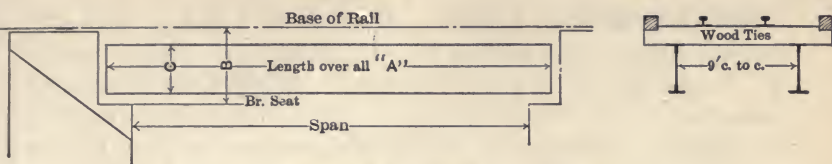

Fig. 23. Deck Plate Girders, 9' 0" centers.

TABLE 50.—APPROXIMATE WEIGHT AND COST OF STEEL DECK PLATE BRIDGES (SINGLE TRACK).

Length over all. A.	Base of rail to bridge seat. B.	Depth back to back of angles. C.	Total weight.	Weight of steel per ft. of bridge.	Cost of steel at 5 cts. per lb.	Bridge ties at 12-in. centers.	Average length of floor system.	Cost of floor at \$5 per ft.	Total cost of steel and floor system.
Ft.	Ft. In.	Ft. In.	Lbs.	Lbs.		In.	Ft.		
20	3 9	2 6	12,000	600	\$600	8 × 14	30	\$150	\$750
30	4 6	3 0	19,500	650	975	8 × 14	40	200	1175
40	5 6	4 0	28,000	700	1400	8 × 14	50	250	1650
50	6 6	5 0	40,000	800	2000	8 × 14	60	300	2300
60	8 0	6 0	57,000	950	2850	8 × 14	70	350	3200
70	9 0	7 0	73,500	1050	3675	8 × 14	80	400	4075
80	10 0	8 0	92,000	1150	4600	8 × 14	90	450	5050
90	11 6	9 0	121,500	1350	6075	8 × 14	100	500	6575
100	13 0	10 0	150,000	1500	7500	8 × 14	110	550	8050

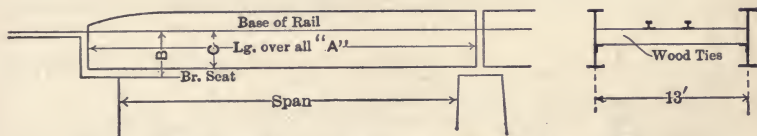

Fig. 24. Half Deck Plate Girders, 13 ft. centers.

TABLE 51.—APPROXIMATE WEIGHT AND COST OF STEEL HALF DECK PLATE BRIDGES (SINGLE TRACK).

Length over all. A.	Base of rail to bridge seat. B.	Depth back to back of angles. C.	Total weight.	Weight of steel per ft. of bridge.	Cost of steel at 5 cts. per lb.	Bridge ties at 12-in. centers.	Average length of floor system.	Cost of floor system at \$5 per ft.	Total cost of steel and floor system.
Ft.	Ft. In.	Ft.	Lbs.	Lbs.		In.	Ft.		
20	1 7	.....	13,000	650	\$650	8 × 16	30	\$150	\$800
30	1 7	.....	21,000	700	1050	8 × 16	40	200	1250
40	1 7	4	30,000	750	1500	8 × 16	50	250	1750
50	2 6	5	42,500	850	2125	8 × 16	60	300	2425
60	4 0	6	60,000	1000	3000	8 × 16	70	350	3350
70	4 9	7	80,500	1150	4025	8 × 16	80	400	4425
80	5 9	8	100,000	1250	5000	8 × 16	90	450	5450

For quantities in abutments and piers, see pages 84, 86, and 87.

**Deck and Through Trusses.** (Figs. 25 and 26.) — Deck and through lattice truss bridges are fabricated from plates, angles, etc., and shop riveted in sections for different members; the trusses are usually shop riveted and shipped in one or two lengths, the frames, bracing, etc., being field riveted to them during erection at the site.

The deck bridges have cross brace frames at every panel and longitudinal bracing top and bottom; the floor is placed on top of the main girders or independent floor beams, and stringers are inserted on which the floor rests.

The through bridges have floor beams every panel crosswise, with stringers running lengthwise, riveted to the floor beams. The trusses are cross braced top and bottom in panels, with heavy portal bracing at the inclined arms of each end. The floor is secured to the steel stringers and carries the rails and guards.

Deck truss bridges are used when there is ample clearance, and for high crossings, where it would not be economical to place smaller spans.

Through bridges are used when the clearance is limited, and at wide crossings, where it would not be economical to place shorter spans.

Approximate cost and weight of Deck and Through Truss Bridges are given in Tables 52 and 53.

**Drawbridges.** (Fig. 27.) — Drawbridges are fabricated and built in a similar manner to the through and deck truss bridges already described. In all cases it is necessary to provide operating mechanism to open and close, lift or lower the same.

They are used for crossing navigable water or canals.

Approximate cost and weight of a few drawbridges are given in Table 54.

**Live Load.** — The steel bridges and trestles, for which weights and quantities are given, are assumed to carry, in addition to the dead load, two consolidated engines coupled as shown in diagram below, followed by a train load of 4000 pounds per lineal foot. Floor consists of wood ties, spaced and proportioned to carry the maximum wheel load, distributed over 3 ties, the outer fiber stress on the timber not to exceed 1000 pounds per square inch (without impact).



**Dead Load.** — For calculating stresses the timber weight is assumed at  $4\frac{1}{2}$  pounds per foot B. M., and the weight of rails, spikes, and joints at 100 pounds per lineal foot of track.

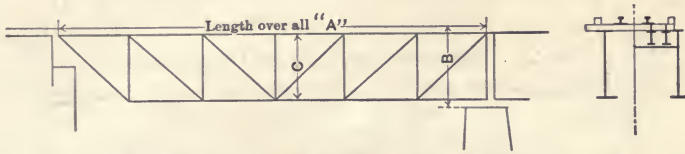

Fig. 25. Deck Lattice Riveted Trusses.

TABLE 52. — APPROXIMATE WEIGHT AND COST OF STEEL DECK LATTICE RIVETED TRUSS BRIDGES (SINGLE TRACK).

Width center to center of girders.	Length over all.	Base of rail to bridge seat.	Depth center to center of chords.	Total weight.	Weight of steel per ft. of bridge.	Cost of steel at 5 cts. per lb.	Bridge ties at 12-in. centers.	Average length of floor system.	Cost of floor system at \$5 per ft.	Total cost of steel and floor system.
Ft.	A.	B.	C.	Lbs.	Lbs.		In.	Ft.		
9	100	13 0	10 6	150,000	1500	\$7,500	8 × 14	110	\$550	\$8,050
9	125	16 0	13 0	225,000	1800	11,250	8 × 14	135	675	11,925
16	150	27 3	25 6	315,000	2100	15,750	8 × 10	160	800	16,550
18	175	28 6	28 0	420,000	2400	21,000	8 × 10	185	925	21,925
20	200	30 6	30 0	540,000	2700	27,000	8 × 10	210	1050	28,050

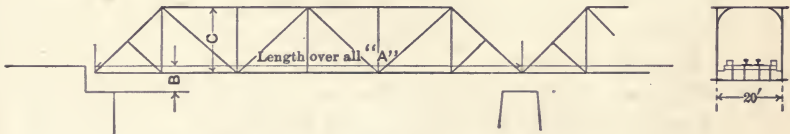

Fig. 26. Through Lattice Riveted Trusses.

TABLE 53. — APPROXIMATE WEIGHT AND COST OF STEEL THROUGH RIVETED TRUSS BRIDGES (SINGLE TRACK).

Length over all.	Base of rail to bridge seat.	Depth center to center of chords.	Total weight.	Weight of steel per ft. of bridge.	Cost of steel at 5 cts. per lb.	Bridge ties at 12-in. centers.	Average length of floor system.	Cost of floor system at \$5 per ft.	Total cost of steel and floor system.
A.	B.		Lbs.	Lbs.		In.	Ft.		
100	6 0	22 6	180,000	1800	\$9,000	8 × 10	110	\$550	\$9,550
125	6 6	25 0	262,500	2100	13,125	8 × 10	135	675	13,800
150	7 0	27 6	360,000	2400	18,000	8 × 10	160	800	18,800
175	7 6	30 0	472,700	2700	23,635	8 × 10	185	925	24,560
200	8 0	32 6	600,000	3000	30,000	8 × 10	210	1050	31,050

For quantities in abutments and piers, see pages 84, 86, and 87.

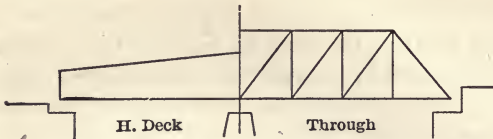

FIG. 27. Half Deck and Through Drawbridges.

TABLE 54.—APPROXIMATE WEIGHT AND COST OF STEEL DRAWBRIDGES (SINGLE TRACK).

Length over all. A.	Kind of bridge.	Width center to center of chords.		Total weight.		Weight of steel per ft. of bridge.		Cost of steel at 5 cts. per lb.		Bridge ties at 12-in. centers.		Average length of floor system.		Cost of floor system at \$6 per ft.		Total cost of steel and floor system.	
		Ft.	In.	Lbs.	Lbs.	Lbs.	\$	In.	Ft.	\$	\$	\$					
70	H. deck pl.	12	7	75,000	1070	\$3,750	8 × 15	70	\$420	\$4,170							
130	Deck pl.	9	0	216,000	1670	10,800	8 × 16	130	780	11,580							
250	Thro' latt.	18	6	750,000	3000	37,500	8 × 10	250	1500	39,000							

C. P. R. BRIDGE UNIT STRESSES.

Unit Strains. —

Axial tension on the net section..... 16,000

Axial compression in the gross section.....  $16,000 - 70 \frac{l}{r}$

Where "l" is the length of the member in inches and "r" is the least radius of gyration in inches.

Bending, on the extreme fibers on rolled shapes and built-up sections and girders, net section..... 16,000

On the extreme fibers of pins..... 24,000

Shearing.

Shop driven rivets..... 11,000

Field driven rivets and turned bolts..... 8,000

Plate girder webs, gross section..... 10,000

Pins:..... 12,000

Bearing.

Shop driven rivets..... 22,000

Field driven rivets and turned bolts..... 16,000

Expansion rollers per lineal inch.....  $600 \times d$

Where "d" is the diameter of the roller in inches.

Masonry..... 400

TABLE 55. — MIDDLE ORDINATES OF CURVES ON BRIDGE SPANS.

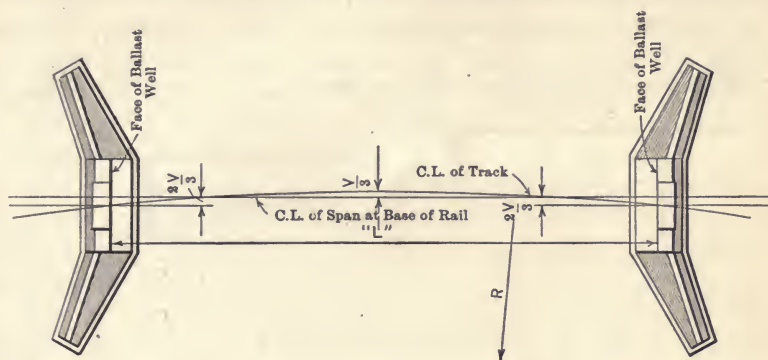

VALUES OF R.

1°	1° 30'	2°	2° 30'	3°	3° 30'	4°	4° 30'	5°	5° 30'	6°	6° 30'
5730	3820	2865	2292	1910	1637.1	1432.5	1273.6	1146.3	1042	955.3	881.8

VALUES OF V.

Span.	"L"	1°	1° 30'	2°	2° 30'	3°	3° 30'	4°	4° 30'	5°	5° 30'	6°	6° 30'
20	23 8	$\frac{1}{8}$	$\frac{7}{16}$	$\frac{1}{4}$	$\frac{3}{8}$	$\frac{1}{2}$	$\frac{5}{8}$	$\frac{3}{4}$	$\frac{7}{8}$	$\frac{1}{2}$	$\frac{1}{4}$	$\frac{1}{8}$	$\frac{1}{16}$
30	33 8	$\frac{1}{4}$	$\frac{3}{8}$	$\frac{1}{2}$	$\frac{5}{8}$	$\frac{3}{4}$	$\frac{7}{8}$	$1\frac{1}{8}$	$1\frac{1}{4}$	$\frac{1}{2}$	$\frac{1}{4}$	$\frac{1}{8}$	$\frac{1}{16}$
40	43 6	$\frac{1}{2}$	$\frac{5}{8}$	$\frac{3}{4}$	$1\frac{1}{8}$	$1\frac{1}{4}$	$1\frac{3}{8}$	$1\frac{1}{2}$	$1\frac{5}{8}$	$\frac{3}{4}$	$\frac{1}{2}$	$\frac{1}{4}$	$\frac{1}{8}$
50	54 6	$\frac{3}{4}$	$1\frac{1}{8}$	$1\frac{1}{4}$	$1\frac{3}{8}$	$1\frac{5}{8}$	$1\frac{7}{8}$	$2\frac{1}{8}$	$2\frac{1}{4}$	$1\frac{3}{4}$	$1\frac{1}{2}$	$\frac{3}{4}$	$\frac{1}{2}$
60	66 0	$1\frac{1}{8}$	$1\frac{3}{8}$	$1\frac{5}{8}$	$2\frac{1}{8}$	$2\frac{3}{8}$	$2\frac{5}{8}$	$3\frac{1}{8}$	$3\frac{3}{8}$	$2\frac{1}{4}$	$2\frac{1}{2}$	$1\frac{3}{4}$	$1\frac{1}{2}$
70	75 6	$1\frac{3}{8}$	$1\frac{5}{8}$	$2\frac{1}{8}$	$2\frac{3}{8}$	$2\frac{5}{8}$	$3\frac{1}{8}$	$3\frac{3}{8}$	$3\frac{5}{8}$	$2\frac{3}{4}$	$2\frac{5}{8}$	$1\frac{7}{8}$	$1\frac{5}{8}$
80	86 0	$1\frac{5}{8}$	$1\frac{7}{8}$	$2\frac{3}{8}$	$2\frac{5}{8}$	$3\frac{1}{8}$	$3\frac{3}{8}$	$3\frac{5}{8}$	$4\frac{1}{8}$	$3\frac{1}{4}$	$3\frac{3}{8}$	$2\frac{1}{4}$	$2\frac{1}{8}$
90	97 8	$2\frac{1}{8}$	$2\frac{3}{8}$	$2\frac{5}{8}$	$3\frac{1}{8}$	$3\frac{3}{8}$	$3\frac{5}{8}$	$4\frac{1}{8}$	$4\frac{3}{8}$	$3\frac{3}{4}$	$3\frac{5}{8}$	$2\frac{3}{4}$	$2\frac{1}{4}$
100	103 5	$2\frac{3}{8}$	$2\frac{5}{8}$	$3\frac{1}{8}$	$3\frac{3}{8}$	$3\frac{5}{8}$	$4\frac{1}{8}$	$4\frac{3}{8}$	$4\frac{5}{8}$	$4\frac{1}{4}$	$4\frac{3}{8}$	$3\frac{1}{4}$	$3\frac{1}{8}$
150	158 3	$6\frac{1}{8}$	$6\frac{3}{8}$	$6\frac{5}{8}$	$7\frac{1}{8}$	$7\frac{3}{8}$	$7\frac{5}{8}$	$8\frac{1}{8}$	$8\frac{3}{8}$	$7\frac{3}{4}$	$7\frac{5}{8}$	$6\frac{3}{4}$	$6\frac{1}{4}$

**Bridge and Trestle Guards.**— It is usual to place outer and inner guards over the floors of all deck and trestle bridges. A very common method is to place wooden guards of 6 in. by 6 in. timbers on the outside with old rails on the inside of the running rails as shown in Fig. 27a, two rails being used for deck and three rails for through bridges for the inner guard. The outer guard is daped two inches between floor beams to prevent bunching of

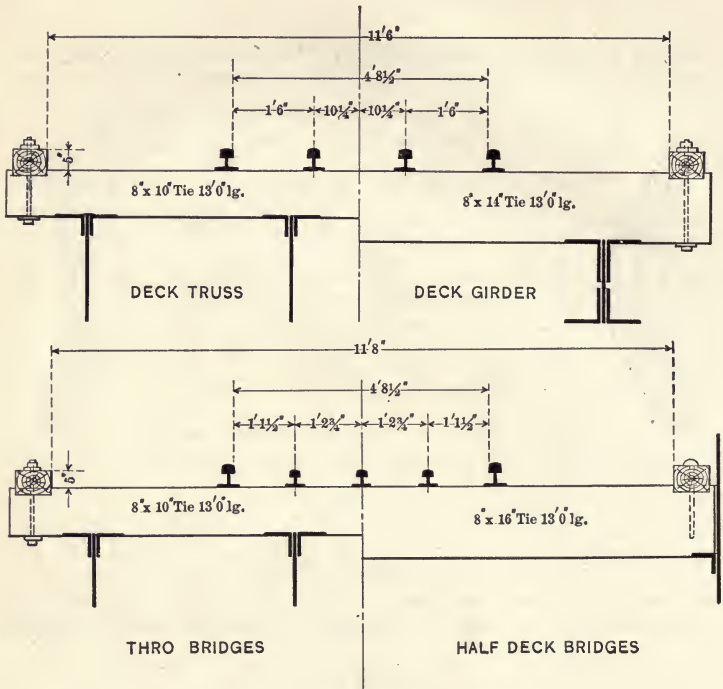

Fig. 27a. Bridge and Trestle Guards.

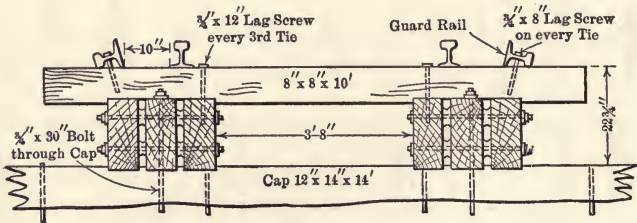

Fig. 27b.

ties in case of a derailment. Another method is shown in Fig. 27b, which provides an outer guard only consisting of old rails laid on edge.

**HIGHWAY BRIDGES.**

**Street Bridges over the Railroad.** — The type of street bridge to adopt, will, under ordinary conditions, depend on the distance available between tracks for the introduction of intermediate supports, the width of the street and, to some extent, on the overhead allowable clearance, which may have a bearing on the depth.

Three general types may be considered:

1. A structure with one span.
2. A structure with three or more spans with intermediate supports but no support between tracks.
3. A structure with two or more spans with intermediate supports and supports between tracks.

The usual overhead clearance is between 18' and 22' 6". When there are no supports between tracks, the track centers are usually 13' centers; when supports are introduced between tracks, 17' to 18' between tracks are necessary for proper clearance.

The floor should be of minimum thickness, and supports between tracks should, where possible, be avoided; the design should provide for additional future tracks with the least possible alteration.

The deck type of structure, either concrete or steel, is usually adopted for streets with narrow roadways and short spans, not exceeding three tracks. Streets with wide roadways and long spans, the through type with girders projecting above the roadway, will be necessary and reinforced concrete cannot be used to advantage but a combination of steel and concrete can be used.

For narrow roadways, but two lines of girders need project above or below the roadway, one on either side at the curbs but for wide roadways center girders may also be required.

**Cost of Street Bridges over the Railroad.** — Comparative costs of street bridges over the railroad for track depression for 60 and 66 ft. streets with and without street car tracks are from estimates by C. N. Bainbridge. Railway tracks are 13 ft. centers where there are no intermediate supports and 18 ft. when supports come between tracks; the clearance above rail is 20 ft.

The bridges are figured for a 24 ton concentrated load on two axles 10 ft. centers and 5 ft. gauge and two 40 ton street cars, with 150 lb. per sq. ft. on the portion of the sidewalks and roadway not occupied by the concentrated load and street cars.

Paving and sidewalks off the bridge have been figured on the basis of 100 ft. of right of way.

The one-span highway bridges illustrated below are for structures spanning two or three railway tracks and can be built either in steel or concrete, type E2 representing the steel and type E3 the concrete structures. For either case the roadways may be 36 ft. with 12 ft. sidewalks or 44 ft. with 11 ft. sidewalks. With the steel structures the depth of bridge is from 3 ft. to 4 ft. 6 in., and for concrete from 3 ft. 6 in. to 5 ft.

The estimated costs for both types either in steel or concrete are given in Table 56, page 111.

TABLE 56. — HIGHWAY BRIDGES.

Over 2 railway tracks — Type E2 — steel or concrete.  
 Over 3 railway tracks — Type E3 — steel or concrete.

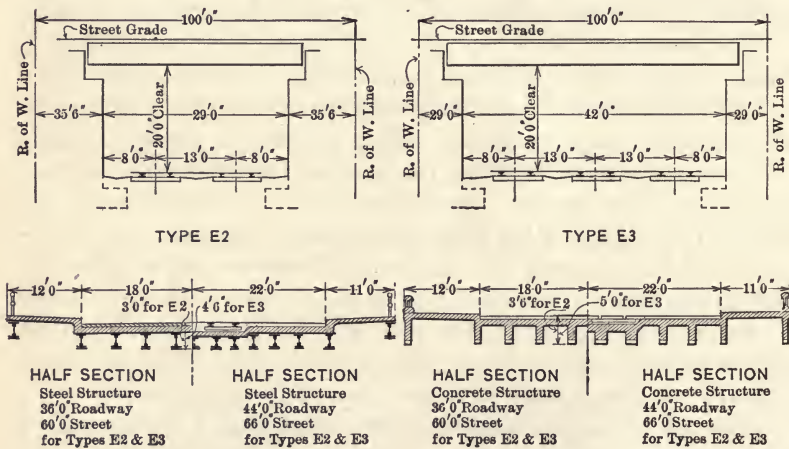

TABLE 56 (Continued).—HIGHWAY BRIDGES.

ESTIMATES—STEEL BRIDGES.

Material.	Unit cost, \$	Type E 2, 60' 0" street, 36' 0" roadway.		Type E 2, 66' 0" street, 44' 0" roadway.		Type E 3, 60' 0" street, 36' 0" roadway.		Type E 3, 66' 0" street, 44' 0" roadway.	
		Quantity.	Cost, \$	Quantity.	Cost, \$	Quantity.	Cost, \$	Quantity.	Cost, \$
Structural steel.....	0.031	60,000 lb.	1,950	90,000 lb.	2,920	95,000 lb.	3,090	130,000 lb.	4,220
Conc. sidewalk on br..	0.40	864 s.f.	345	792 s.f.	320	1,180 s.f.	470	1,078 s.f.	430
Conc. slab on br.....	20.00	36 c.y.	720	44 c.y.	880	49 c.y.	980	60 c.y.	1,200
Reinf. conc. abut.....	10.00	520 c.y.	5,200	560 c.y.	5,600	520 c.y.	5,200	560 c.y.	5,600
Exc. for abut.....	1.00	600 c.y.	600	660 c.y.	660	600 c.y.	600	660 c.y.	660
Backfill.....	0.60	720 c.y.	430	800 c.y.	480	720 c.y.	430	800 c.y.	480
Handrail.....	1.50	80 l.f.	120	80 l.f.	120	105 l.f.	160	105 l.f.	160
Paving on br.....	2.25	144 s.y.	320	174 s.y.	390	196 s.y.	440	240 s.y.	540
Paving on R. of W. but off bridge.....	3.25	254 s.y.	825	312 s.y.	1,030	204 s.y.	665	250 s.y.	810
Sidewalk on R. of W. but off bridge.....	0.15	1,536 s.f.	230	1,408 s.f.	210	1,220 s.f.	185	1,122 s.f.	170
Eng. and cont.....	20%	.....	2,160	.....	2,490	.....	2,480	.....	2,830
Totals.....	....	.....	12,900	.....	15,100	.....	14,700	.....	17,100

ESTIMATES—CONCRETE BRIDGES.

Material.	Unit cost, \$	Type E 2, 60' 0" street, 36' 0" roadway.		Type E 2, 66' 0" street, 44' 0" roadway.		Type E 3, 60' 0" street, 36' 0" roadway.		Type E 3, 66' 0" street, 44' 0" roadway.	
		Quantity.	Cost, \$	Quantity.	Cost, \$	Quantity.	Cost, \$	Quantity.	Cost, \$
Conc. floor.....	22.00	100 c.y.	2,200	130 c.y.	2,860	165 c.y.	3,630	190 c.y.	4,180
Reinf. conc. abut.....	10.00	475 c.y.	4,750	515 c.y.	5,150	475 c.y.	4,750	515 c.y.	5,150
Exc. for abut.....	1.00	600 c.y.	600	660 c.y.	660	600 c.y.	600	660 c.y.	660
Backfill.....	0.60	720 c.y.	430	800 c.y.	480	720 c.y.	430	800 c.y.	480
Paving on br.....	2.25	144 s.y.	325	174 s.y.	350	180 s.y.	405	220 s.y.	500
Paving on R. of W. but off bridge.....	3.25	254 s.y.	825	312 s.y.	1,030	220 s.y.	715	270 s.y.	880
Sidewalk on R. of W. but off bridge.....	0.15	1,536 s.f.	230	1,408 s.f.	210	1,320 s.f.	200	1,210 s.f.	180
Handrail.....	2.25	80 l.f.	180	80 l.f.	180	105 l.f.	230	105 l.f.	230
Eng. and cont.....	20%	.....	1,860	.....	2,240	.....	2,240	.....	2,440
Totals.....	....	.....	11,400	.....	13,200	.....	13,200	.....	14,700

One-span highway bridges over four tracks and six tracks are illustrated below, using either two or three girders over the roadway. When two girders are used the depth of floor steel will be 4 ft. for a 60 ft. street and 4 ft. 6 in. for a 66 ft. street. Where three girders are used the depth will be 3 ft. for the 60 ft. street and 3 ft. 3 in. for the 66 ft. street. The estimated costs for both types are given in Table 57, page 113.

ONE-SPAN HIGHWAY BRIDGES.

Over 4 railway tracks — Type E 4 — Two or three girder spans.

Over 6 railway tracks — Type E 6 — Two or three girder spans.

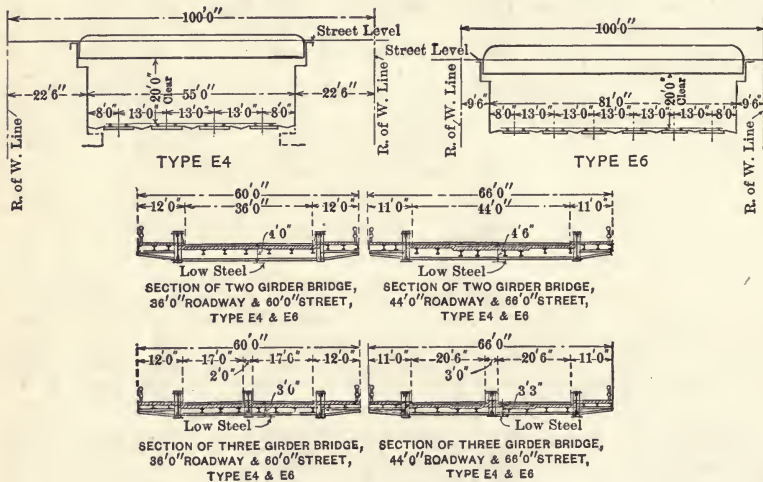



TABLE 57.—TYPES E 4 AND E 6, STEEL STRUCTURES SPANNING FOUR AND SIX TRACKS WITH SINGLE SPAN.

ESTIMATES E 4 TYPE.

Material.	Unit cost, \$	Type E 4, 2 girders, 60' 0" street, 36' 0" roadway.		Type E 4, 3 girders, 60' 0" street, 36' 0" roadway.		Type E 4, 2 girders, 66' 0" street, 44' 0" roadway.		Type E 4, 3 girders, 66' 0" street, 44' 0" roadway.	
		Quantity.	Cost, \$	Quantity.	Cost, \$	Quantity.	Cost, \$	Quantity.	Cost, \$
Structural steel....	0.03½	166,000 lb.	5,395	127,000 lb.	4,130	238,000 lb.	7,735	180,000 lb.	5,850
Concrete sidewalk on bridge.....	0.40	1,200 s.f.	480	1,200 s.f.	480	1,080 s.f.	430	1,080 s.f.	430
Conc. slabs on br....	20.00	67 c.y.	1,340	74 c.y.	1,480	80 c.y.	1,600	85 c.y.	1,700
Reinf. conc. abut....	10.00	520 c.y.	5,200	520 c.y.	5,200	560 c.y.	5,600	560 c.y.	5,600
Exc. for abut.....	1.00	600 c.y.	600	600 c.y.	600	660 c.y.	660	660 c.y.	660
Backfill.....	0.60	720 c.y.	430	720 c.y.	430	800 c.y.	480	800 c.y.	480
Handrail.....	1.50	130 l.f.	200	130 l.f.	200	130 l.f.	200	130 l.f.	200
Paving on br.....	2.25	240 s.y.	540	220 s.y.	495	295 s.y.	665	275 s.y.	620
Paving on R. of W. but off bridge....	3.25	160 s.y.	520	160 s.y.	520	195 s.y.	630	195 s.y.	630
Sidewalk on R. of W. but off bridge....	0.15	960 s.f.	145	960 s.f.	145	880 s.f.	130	880 s.f.	130
Eng. and cont.....	20%	.....	2,950	.....	2,720	.....	3,570	.....	3,300
Totals.....	.....	.....	17,800	.....	16,400	.....	21,700	.....	19,600

ESTIMATES E 6 TYPE.

Material.	Unit cost, \$	Type E 6, 2 girders, 60' 0" street, 36' 0" roadway.		Type E 6, 3 girders, 60' 0" street, 36' 0" roadway.		Type E 6, 2 girders, 66' 0" street, 44' 0" roadway.		Type E 6, 3 girders, 66' 0" street, 44' 0" roadway.	
		Quantity.	Cost, \$	Quantity.	Cost, \$	Quantity.	Cost, \$	Quantity.	Cost, \$
Structural steel....	0.03½	300,000 lb.	9,750	240,000 lb.	7,800	410,000 lb.	13,320	324,000 lb.	10,530
Concrete sidewalk on bridge.....	0.40	1,800 s.f.	720	1,800 s.f.	720	1,584 s.f.	630	1,584 s.f.	630
Concrete slabs.....	20.00	100 c.y.	2,000	110 c.y.	2,200	117 c.y.	2,340	124 c.y.	2,480
Reinf. conc. abut....	10.00	540 c.y.	5,400	540 c.y.	5,400	580 c.y.	5,800	580 c.y.	5,800
Exc. for abut.....	1.00	620 c.y.	620	620 c.y.	620	680 c.y.	680	680 c.y.	680
Backfill.....	0.60	750 c.y.	450	750 c.y.	450	830 c.y.	500	830 c.y.	500
Handrail.....	1.50	200 l.f.	300	200 l.f.	300	200 l.f.	300	200 l.f.	300
Paving on br.....	2.25	360 s.y.	810	330 s.y.	740	430 s.y.	970	400 s.y.	900
Paving on R. of W. but off bridge....	3.25	14 s.y.	45	14 s.y.	45	59 s.y.	191	59 s.y.	191
Sidewalk on R. of W. but off br.....	0.15	240 s.f.	35	240 s.f.	35	528 s.f.	79	528 s.f.	79
Eng. and cont.....	20%	.....	4,070	.....	3,690	.....	4,990	.....	4,410
Totals.....	.....	.....	24,200	.....	22,000	.....	29,800	.....	26,500

Steel highway bridges with three spans with intermediate supports between tracks are illustrated below, over two, four and six railway tracks, for varying conditions, and the costs of the various structures are given in Table 58, page 115.

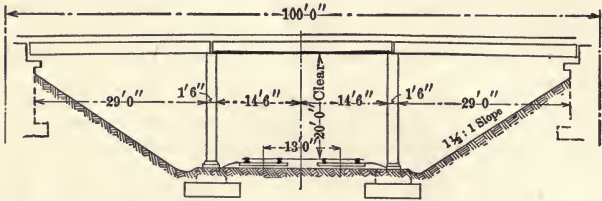

TYPES F2, ELEVATION, 2 TRACK SCHEME

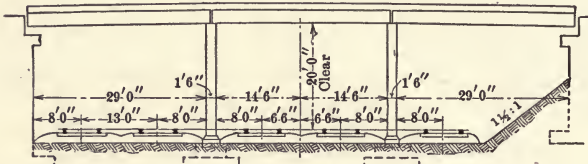

HALF ELEVATION, 6 TRACK SCHEME  
TYPES F6

HALF ELEVATION, 4 TRACK SCHEME  
TYPES F4

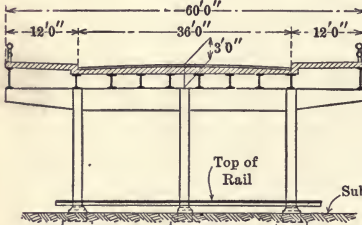

CROSS-SECTION, 60'-0" STREET, 36'-0" ROADWAY  
TYPES F2 - F4

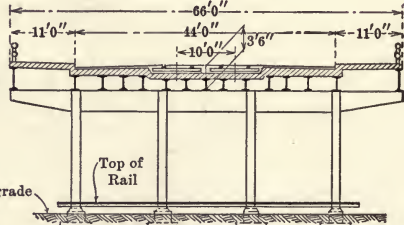

CROSS-SECTION, 66'-0" STREET, 44'-0" ROADWAY  
TYPES F6

TABLE 58.—TYPES F 2, 4 AND 6, STEEL STRUCTURES SPANNING TWO, FOUR AND SIX TRACKS WITH THREE SPANS.

ESTIMATES, TYPES F 2, 4 and 6.

Material.	Unit cost, \$	Type F 2, 60' 0" street, 36' 0" roadway.		Type F 2, 66' 0" street, 44' 0" roadway.		Type F 4, 60' 0" street, 36' 0" roadway.	
		Quantity.	Cost, \$	Quantity.	Cost, \$	Quantity.	Cost, \$
Structural steel.....	0.03½	215,000 lb.	6,990	315,000 lb.	10,240	215,000 lb.	6,990
Conc. sidewalk on br.....	0.40	2,400 s.f.	960	2,200 s.f.	880	2,400 s.f.	960
Conc. slab.....	22.00	100 c.y.	2,200	165 c.y.	3,630	100 c.y.	2,200
Conc. col. footings.....	8.00	40 c.y.	320	50 c.y.	400	40 c.y.	320
Reinf. conc. abut.....	10.00	.....	.....	.....	.....	330 c.y.	3,300
Plain conc. abut.....	7.00	210 c.y.	1,470	230 c.y.	1,610	.....	.....
Exc. for abut. and col. footings.	1.00	1,100 c.y.	1,100	1,240 c.y.	1,240	1,380 c.y.	1,380
Backfill.....	0.60	500 c.y.	300	550 c.y.	330	1,100 c.y.	660
Paving on br.....	2.25	380 s.y.	855	460 s.y.	1,030	380 s.y.	855
Paving on R. of W. but off br.	3.25	20 s.y.	65	30 s.y.	100	20 s.y.	65
Sidewalk on R. of W. but off br.	0.15	132 s.f.	20	120 s.f.	20	132 s.f.	20
Handrail.....	1.50	200 l.f.	300	200 l.f.	300	200 l.f.	300
Eng. and cont.....	20%	.....	2,920	.....	3,920	.....	3,450
Totals.....	.....	.....	17,500	.....	23,700	.....	20,500

Material.	Unit cost, \$	Type F 4, 66' 0" street, 44' 0" roadway.		Type F 6, 60' 0" street, 36' 0" roadway.		Type F 6, 66' 0" street, 44' 0" roadway.	
		Quantity.	Cost, \$	Quantity.	Cost, \$	Quantity.	Cost, \$
Structural steel.....	0.03½	315,000 lb.	10,240	215,000 lb.	6,990	315,000 lb.	10,240
Conc. sidewalk on br.....	0.40	2,200 s.f.	880	2,400 s.f.	960	2,200 s.f.	880
Conc. slab.....	22.00	165 c.y.	3,630	100 c.y.	2,200	165 c.y.	3,630
Conc. col. footings.....	8.00	50 c.y.	400	40 c.y.	320	50 c.y.	400
Reinf. conc. abut.....	10.00	360 c.y.	3,600	474 c.y.	4,740	517 c.y.	5,170
Plain conc. abut.....	7.00	.....	.....	.....	.....	.....	.....
Exc. for abut. and col. footings.	1.00	1,540 c.y.	1,540	730 c.y.	730	840 c.y.	840
Backfill.....	0.60	1,200 c.y.	720	1,380 c.y.	830	1,500 c.y.	900
Paving on br.....	2.25	460 s.y.	1,030	380 s.y.	855	460 s.y.	1,030
Paving on R. of W. but off br..	3.25	30 s.y.	100	20 s.y.	65	30 s.y.	100
Sidewalk on R. of W. but off br.	0.15	120 s.f.	20	132 s.f.	20	120 s.f.	20
Handrail.....	1.50	200 l.f.	300	200 l.f.	300	200 l.f.	300
Eng. and cont.....	20%	.....	4,540	.....	3,590	.....	4,690
Totals.....	.....	.....	27,000	.....	21,600	.....	28,200

Concrete highway bridges for spans with intermediate supports are shown below for two, four and six track crossings and the estimated cost of these structures are given in Table 59, page 117.

TYPE F, CONCRETE STRUCTURES SPANNING TWO, FOUR AND SIX TRACKS WITH THREE SPANS.

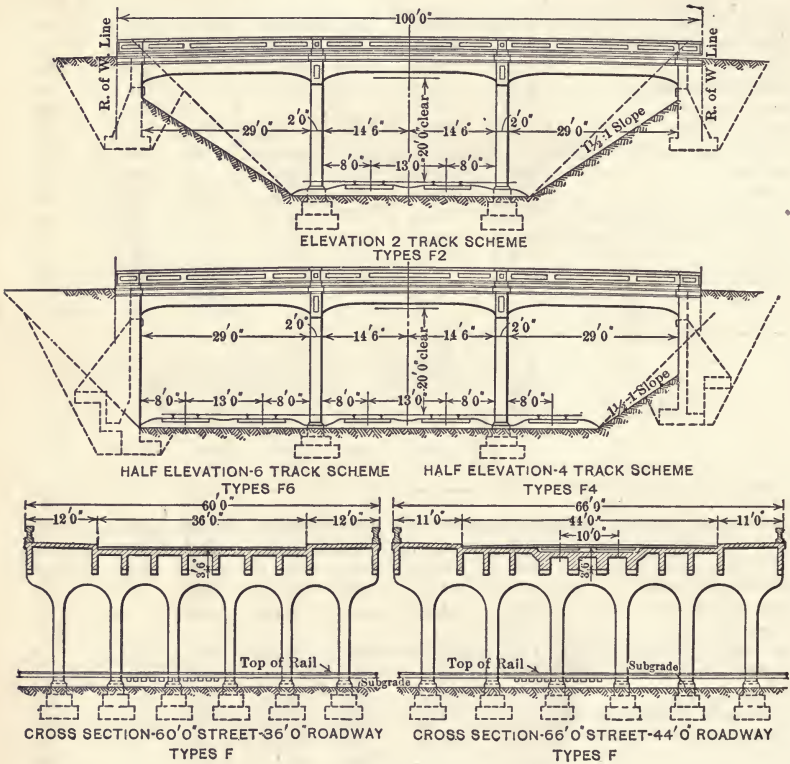

TABLE 59.—TYPE F, CONCRETE STRUCTURES SPANNING TWO, FOUR AND SIX TRACKS WITH THREE SPANS

ESTIMATES.

Material.	Unit cost.	Type F 2, 60' 0" street, 36' 0" roadway.		Type F 2, 66' 0" street, 44' 0" roadway.		Type F 4, 60' 0" street, 36' 0" roadway.	
		Quantity.	Cost.	Quantity.	Cost.	Quantity.	Cost.
Concrete floor.....	\$22.00	280 c.y.	\$6,160	360 c.y.	\$7,920	280 c.y.	\$6,160
Concrete col's, neat work .....	23.00	34 "	780	40 "	920	34 "	780
Concrete col's, footings .....	8.00	60 "	480	74 "	590	60 "	480
Reinforced concrete abutments.....	10.00	"	"	"	"	330 "	3,300
Plain concrete abutment.....	7.00	210 c.y.	1,410	230 c.y.	1,610	"	"
Exc. for abut. and col. footings....	1.00	1200 "	1,200	1340 "	1,340	1480 c.y.	1,480
Backfill .....	0.60	550 "	330	600 "	360	1100 "	660
Paving on bridge.....	2.25	380 s.y.	850	460 s.y.	1,040	330 s.y.	850
Paving on right of way but off br..	3.25	20 "	60	30 "	100	20 "	60
Sidewalk on right of way but off br.	0.15	132 s.f.	20	120 s.f.	20	132 s.f.	20
Handrail.....	2.25	200 l.f.	450	200 l.f.	450	200 l.f.	450
Engineering and contracting.....	20%	"	2,400	"	2,850	"	2,860
Totals.....			\$14,200		\$17,200		\$17,100

Material.	Unit cost.	Type F 4, 66' 0" street, 44' 0" roadway.		Type F 6, 60' 0" street, 36' 0" roadway.		Type F 6, 66' 0" street, 44' 0" roadway.	
		Quantity.	Cost.	Quantity.	Cost.	Quantity.	Cost.
Concrete floor.....	\$22.00	360 c.y.	\$7,920	280 c.y.	\$6,160	360 c.y.	\$7,920
Concrete col's, neat work .....	23.00	40 "	920	34 "	780	40 "	920
Concrete col's, footings .....	8.00	74 "	590	60 "	480	74 "	590
Reinforced concrete abutment.....	10.00	360 "	3,600	474 "	4,740	515 "	5,150
Plain concrete abutment.....	7.00	"	"	"	"	"	"
Exc. for abut. and col. footings....	1.00	1640 c.y.	1,640	830 c.y.	830	940 c.y.	940
Backfill .....	0.60	1200 "	720	1380 "	830	1500 "	900
Paving on bridge.....	2.25	460 s.y.	1,040	380 s.y.	850	460 s.y.	1,040
Paving on right of way but off br..	3.25	30 "	100	20 "	60	30 "	100
Sidewalk on right of way but off br.	0.15	120 s.f.	20	132 s.f.	20	120 s.f.	20
Handrail.....	2.25	200 l.f.	450	200 l.f.	450	200 l.f.	450
Engineering and contracting.....	20%	"	3,400	"	3,000	"	3,570
Totals.....			\$20,400		\$18,200		\$21,600

The foregoing designs for concrete highway bridges are of a more pleasing character than the preceding structures and are very suitable for residential districts in towns and cities, for grading separation work. Owing to the high cost of steel this type of structure is likely to be very much more economical than a combination or all steel design at the present time.

**Street Bridge for Track Depression, M. P. Ry.** — The street bridge over the Missouri Pacific Tracks at Arsenal Street, St. Louis, is shown, Fig. 28.

This bridge is 60 ft. wide, 110 ft. long with three spans of 31 ft. 6 in., having a vertical clearance of 18 ft. over the tracks and was designed for an 18 ton roller on roadway stringers; a 16 ton concentrated wheel load on roadway slabs; a uniform roadway load of 125 lb. per sq. ft.; a uniform sidewalk load of 100 lb. per sq. ft.; and a 50 ton street railway cinder car on track stringers. Impact 30 per cent. The unit stresses were 450 lb. axial comp. in concrete; 650 lb. flexure comp. in concrete; 120 lb. shear in concrete; 16,000 lb. tension in steel; 50 lb. bond in plain bars; 120 lb. bond in deformed bars.

Abutments are of gravity section without reinforcement, excepting in the portion of the front wall back of the bridge seat.

The pier bents and the general floor system are of reinforced concrete, the construction of which is shown on Fig. 29. At the abutments all stringers are furnished with cast steel shoes and bed plates. *Eng. News*, Vol. 75, No. 9.

APPROXIMATE QUANTITIES AND COST.

Span lengths.....	31 ft. 6 in.	
Over all depth.....	3 ft. 8 in.	
Average dead weight.....	400 lb. per sq. ft.	
Quantities per square foot:		
Concrete structural, cu. ft.....	2.00	
Reinforcement in slabs, lb.....	4.10	
"    " long'l stringers, lb.....	7.50	
"    " stirrups, lb.....	2.55	
Earth excavation.....	6,300 cu. ft. @ \$0.06.....	\$378
Rock ".....	110 " @ 0.30.....	33
Concrete Class A.....	6,160 " @ 0.33.....	2,033
"    " B.....	11,560 " @ 0.35.....	4,046
"    " C.....	360 " @ 0.90.....	324
Steel reinforcement....	103,300 lbs. @ 0.025.....	2,583
Steel castings.....	3,860 " @ 0.07.....	270
		<hr/> \$9,667
Cost of removing old structure, etc.....		1,833
		<hr/> \$11,500
Supervision and contingencies, 10 per cent.....		1,150
Total.....		<hr/> \$12,650 or
		about \$1.85 per sq. ft.

Details of the floor system are shown, page 120, Fig. 29, including a typical arrangement of bearing and reinforcement.

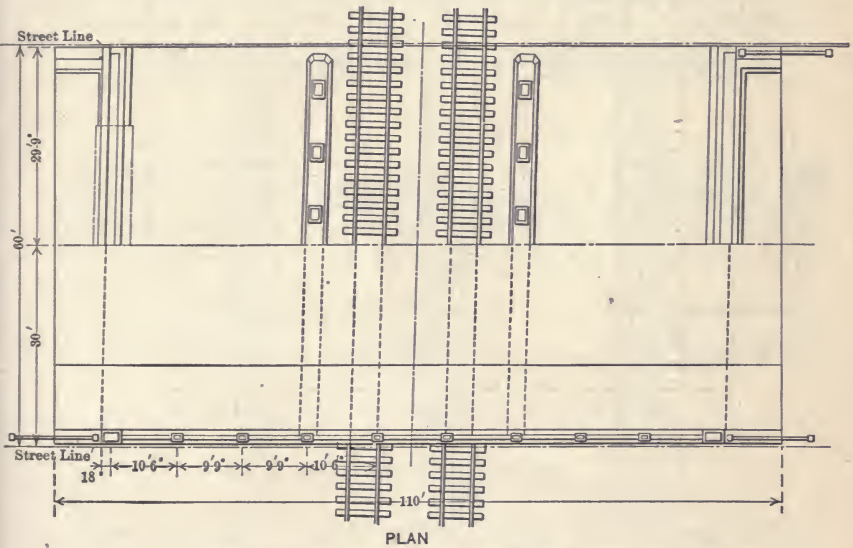
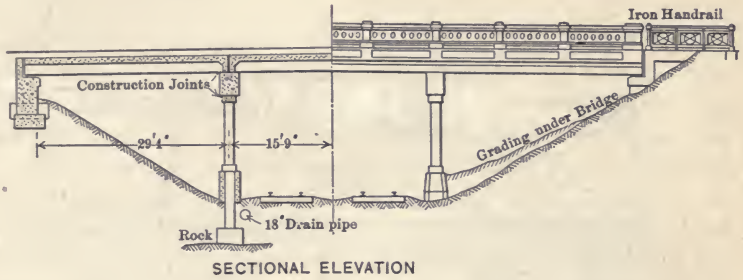

Fig. 28. Arsenal St. Bridge at St. Louis.

The floor of roadway is finished with  $3\frac{1}{2}$  in. wood blocks on a  $\frac{1}{2}$  in. bed of sand supported on the concrete base. The sidewalk is of  $3\frac{1}{2}$  in. concrete reinforced with  $\frac{3}{8}$  in. round bars; the filled portion under the sidewalk slab is composed of cinders.

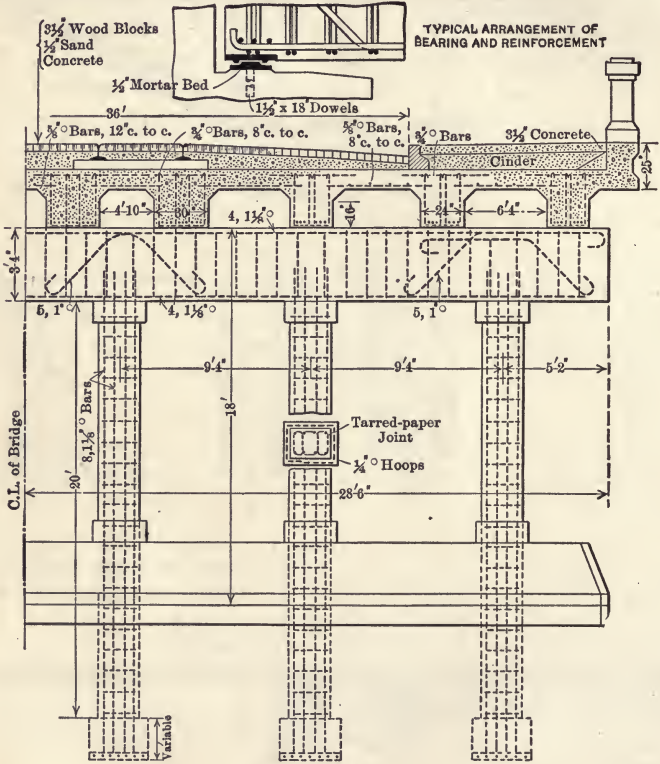

Fig. 29. Details Arsenal St. Bridge at St. Louis.

Other highway bridges of this character are illustrated on page 114 and the estimated costs of same are given in Table 58, page 115. Another type is also shown on page 121 as built on the L. & N. Ry.



**Concrete Overhead Bridges on the L. & N., Fig. 30.** — The structure is built of reinforced concrete providing 28 ft. roadway and two 6 ft. sidewalks, carried on four bents of two columns each, the three spans being 33 ft. each and the clearance under the bridge to rail 22 ft.

The bridge is designed for a live load of 100 lb. per square foot of roadway and sidewalk, or a 35,000 lb. road roller on the roadway and 100 lb. per square foot on the sidewalks. The material being clay the footings are spread, those supporting the end bents being carried down 4 ft. below the ground line and those under the intermediate bents 6 ft.

This structure required 28 tons of steel and 250 cubic yards of concrete, 1 : 2 : 4 mixture. The approximate average cost for estimating for the bridge only is \$6000 or about \$1.50 per square foot taking 40 ft. by 100 ft. as the area covered. If the above bridge had to carry street cars the cost in reinforced concrete would be about \$8000.

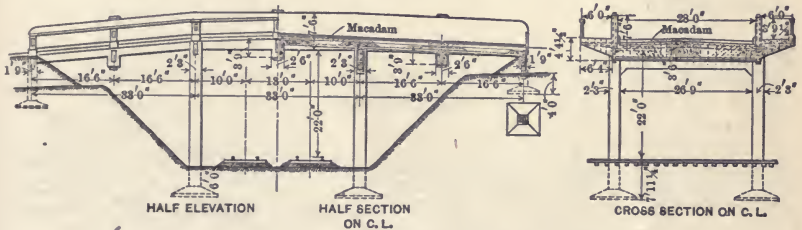

Fig. 30. Concrete Overhead Bridge, L. & N. Ry.

### WOODEN BRIDGES.

**Howe Trusses.** — While timber bridges are not used to the same extent to-day as in former years, there are still some places where good timber is abundant and cheap, where the cost of delivering steel would be high and the probable traffic light.

If properly detailed with moderate spans, any strength required in such structures can be developed and when suitably protected they will last for many years and may, under certain conditions, be favorably considered both for railway and highway traffic.

The structure is usually built with a large excess of strength of the Howe or Towne lattice type.

The chords and braces are made of timber and the vertical rods of steel usually upset, with cast-iron blocks at the angles of braces, which are bolted or doweled into the main members. The best class of timber is used with as few splices as possible.

The loads, quantities, and weights in the table of cost are from Johnson's modern frame structures, taken from the Oregon Pacific (A. A. Schenck, chief engineer) and published in the *Engineering News*, April 26, 1890. The live load assumed was two 88-ton engines followed by a train load of 3000 pounds per foot.

For deck bridges add 20 per cent to the weight of the timber and deduct 20 per cent from the weight of the wrought iron.

To protect the chords from engine sparks, galvanized iron is often used. Sometimes also the timbers are treated by a chemical process to prevent or retard decay, or whitewashed with a fire-resistant compound. They require to be closely inspected at all times.

TABLE 60.—APPROXIMATE COST, WEIGHTS AND QUANTITIES FOR HOWE TRUSS BRIDGES.

Length of span.	Style of truss.	Height of truss.	No. of panels.	Total dead and live load per ft.	Estimated quantities.			Approximate cost erected.
					Timber, ft. B. M.	Wrought iron.	Cast iron.	
Ft.		Ft.				Lbs.	Lbs.	
30	Pony	9	4	6000	10,200	2,200	1,000	\$550
40	Pony	11	4	5500	13,400	3,000	1,300	740
50	Pony	11	6	5200	19,100	5,700	2,900	1170
60	Pony	12	6	4900	22,800	6,800	3,700	1410
70	Pony	13	7	4800	30,000	17,500	8,300	2480
80	Pony	14	8	4800	35,400	22,000	10,000	3010
90	Pony	15	9	4800	42,800	28,700	12,600	3890
90	Through	25	8	4800	41,900	33,100	13,300	4020
100	Through	25	9	4800	48,900	41,600	14,300	4810
110	Through	25	10	4800	54,800	48,200	16,000	5290
120	Through	25	11	4800	62,100	56,900	18,300	6350
130	Through	25	12	4700	70,200	67,300	20,900	7320
140	Through	25	13	4700	78,200	73,900	23,300	8100
150	Through	25	14	4700	86,700	87,300	27,100	9330

Prices assumed: Timber, \$35 per M. ft. B. M. erected; steel, 5 cts. per pound erected; cast iron, 4 cts. per pound erected.

Supervision and contingencies, 10%.

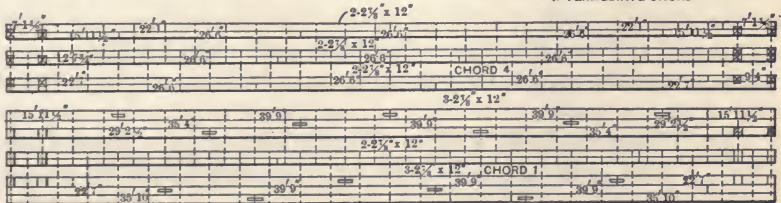
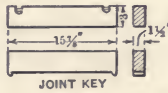
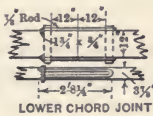
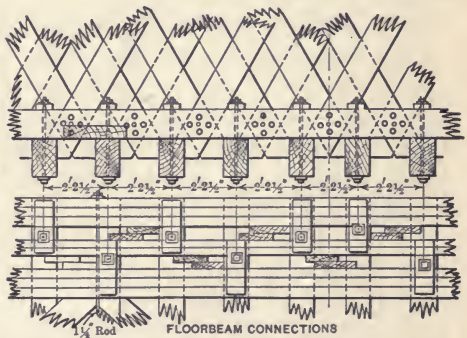
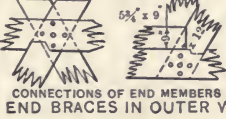
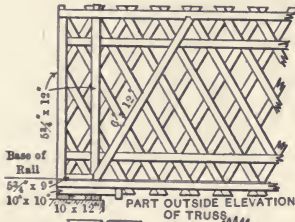
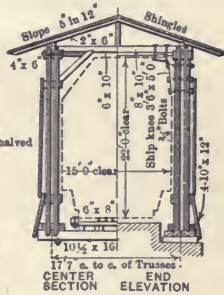
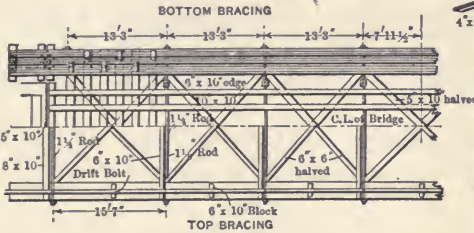
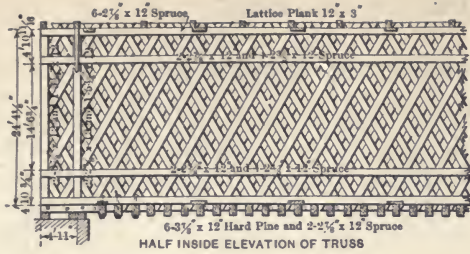

BOTTOM AND TOP CHORD FRAMING PLANS

Fig. 31. Towne Lattice Wood Bridge.

**B. & M. Wooden Truss Bridge, Fig. 31.**

**Loading.** — The span is proportioned for a live load, consisting of a series of locomotives with 25,000 lb. on each of three axles and a 44-ft. wheelbase for engine and tender. A maximum unit strain of 1000 lb. per square inch in tension for the net section and 700 lb. in compression for the gross section is allowed. Floor beams and stringers are proportioned for a maximum fiber stress of 1200 lb. in flexure. A maximum shear of 100 lb. per square inch with the grain, a bearing or crushing pressure of 360 lb. is allowed under bolt washers. Maximum shear on the oak trenails is computed not to exceed 500 and the maximum bearing 400 lb. per square inch.

**Trusses.** — The trusses about  $111\frac{1}{2}$  ft. long and 26 ft. deep over all and  $17\frac{1}{2}$  ft. apart on centers are of the old Towne lattice girder type.

**Web.** — The two sets of web members alternate with the three sets of horizontal members in each of the four chords, packed solidly together and developing double shear in their connections.

The web members are made with single full-length  $3 \times 12$ -in. planks (planed to  $2\frac{7}{8}$  in.) inclined in both directions about 30 deg. from the vertical and connected at each intersection by a pair of horizontal oak trenails or pins 2 in. in diameter, turned to a driving fit in bored holes. Parallel diagonals are spaced about 4 ft. apart on centers.

**Chords.** — The chords are all made with 12-in. pine planks from about 7 to 40 ft. in length. Chord No. 1 is built up with six 4-in. and two 3-in. pieces, chords 2 and 3 are each built up with two 3-in. and four  $2\frac{1}{2}$ -in. and chord 4 is built with six  $2\frac{1}{2}$ -in. pieces. Care is taken to break the joints as widely as possible so that all but one of the members of each chord are continuous at any given cross section.

The chord pieces are connected together and to the diagonal or lattice pieces with four 2-in. trenails and one  $\frac{3}{4}$ -in. bolt at every intersection of the latter.

In chord 1, except at the extreme ends where the very short pieces of the members are really fillers rather than tension members, all of the square butt joints between the chord planks have steel tension splices.

Each joint is made with two vertical  $3 \times \frac{1}{2}$ -in. wrought iron keys. One of them has at each end a rounded knob to receive

the loop, a  $\frac{7}{8}$ -in. U-bar with nuts at the opposite end bearing on a  $\frac{3}{4}$ -in. washer plate or saddle engaging the other gib and secured in position by a slot in the wood and a shoulder on the gib.

In all of the other chords these splices are omitted and the adjacent ends of the timber are simply butt-jointed. They are lapped by the other member of each piece which serves as a splice and is connected to them at frequent intervals by the staggered horizontal trenail and bolt connection to the diagonal planks.

At each end of the span two  $6 \times 12$ -in. vertical posts are bolted to both sides of the truss over the abutment and take bearing on chords 1 and 4. An inclined post of the same dimensions reaches from the foot of one of them, where it abuts against a horizontal shoulder piece, to the top chord and has notched shoulder bearings in both top and bottom chords. The ends of chord 1 have  $10 \times 10$ -in. sill pieces about 9 ft. long to take bearing on three  $10 \times 12$ -in. beams on each abutment. The truss is framed with a camber of about 1 in. per 25 ft. of span.

**Lateral Bracing.** — Top lateral bracing is provided by a Howe truss in the horizontal plane of chord 4 which is made with  $6 \times 6$ -in. diagonal members, halved at their intersections and  $1\frac{1}{8}$ -in. transverse rods and  $6 \times 10$ -in. struts at panel points. The bottom lateral system is similar except that the diagonals are  $5 \times 10$  in., the ties are  $1\frac{1}{4}$  in. in diameter, and the struts are omitted. The top transverse struts are knee-braced at each end with  $6 \times 6$ -in. pieces engaging chord 3, and with  $3 \times 6$ -in. ship knees securely bolted and keyed at the portals.

**Floor.** — The track is carried on  $6 \times 8$ -in. ties, 12 ft. long, laid flat 14 in. apart on centers and supported by a  $10 \times 10$ -in. stringer under each rail and a  $6 \times 10$ -in. side stringer at each end of the tie. The stringers are seated on  $10\frac{1}{2} \times 16$ -in. floor beams, 21 ft. long and  $26\frac{1}{2}$  in. apart on centers, suspended from the lower chords by a  $1\frac{3}{8}$ -in. vertical bolt at each end. The nut on the upper end of the bolt engages a transverse wooden block bearing on two of the three members of the bottom chord.

**Housing.** — The bridge timber is protected from the weather by a light double pitched shingled roof supported on the top chords and top lateral bracing and by vertical sheathing furred out from the outer sides of the trusses.

**Approximate Cost.** — 100,000 ft. B. M. timber and 600 lb. iron and steel, without track, about \$4000.

**Timber Trestles.** — Timber trestles are of two types, pile and frame, and are used principally for rapid or cheap first-cost construction, to be eventually filled or replaced by permanent structures at some future date.

The structure must be made rigid by sway bracing the bents crosswise and longitudinally, to withstand the pull from a moving train, or the thrust when brakes are applied. Trestle failures are frequently caused by insufficient bracing. Trestles of long lengths should have fire breaks; that is, a few bents at varying intervals should be filled in or made fireproof, so that should a fire occur, the whole trestle will not be destroyed.

**Frame Trestles.** (Fig. 33.) — The bents are made of square timber framed together and braced, the economic limit of height being probably 100 feet. The foundation may be piles cut off at ground level, with timber sills on top or masonry piers. The structures must be made rigid by bracing transversely and longitudinally throughout.

Approximate cost and quantities are given in Table 63.

**Pile Trestles.** (Fig. 32.) — The bents are formed of several piles with caps and sway bracing, the floor consisting of longitudinal stringers with cross ties, or solid plank with ballast floor on top.

Owing to the long length of piles required, they rarely exceed 30 feet in height.

For heights over 10 feet up to 20 feet, longitudinal bracing should be inserted at least every fifth panel; over 25 feet every alternative panel should be braced, arranged so as to hold the posts midway to stiffen them as columns.

Approximate cost and quantities are given in Tables 61 and 62.

**Alaska Central Ry.** — Cost of pile trestles were remarkably low on account of a large portion of the timber being cut on the site.

The pile trestles were built with four-pile bents, 12-ft. span, and an average length of piles of 22 ft. The floor system consisted of six  $8 \times 14$ -in. stringers per span, with  $7 \times 8$ -in. ties, 10 ft. long, spaced 14 in. c. to c., and guard rails  $5\frac{1}{2} \times 8$  in. The  $12 \times 14$ -in. caps were hewed, and they, as well as the piles, were cut as close to the bridge sites as possible and floated to place. The sawed timber was furnished by the company's mill

at Seward. There were 3514 lin. ft. of trestle built on residency No. 3, at a cost of \$6.40 per lin. ft., including the cost of moving the pile-driver between bridges.

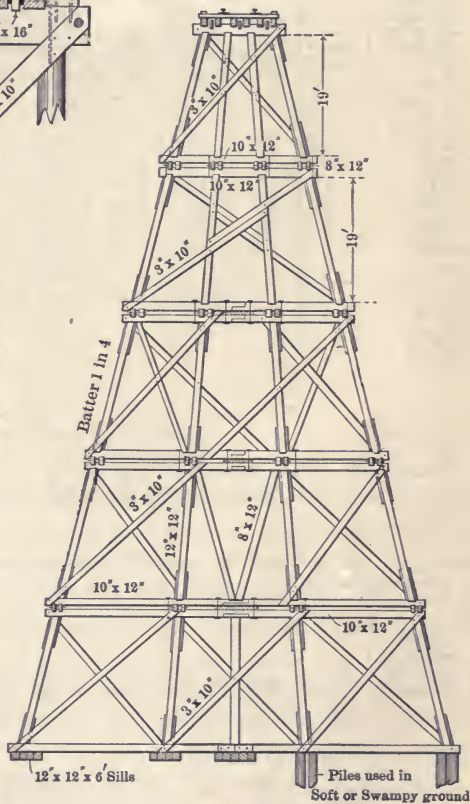
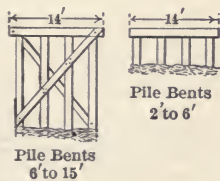
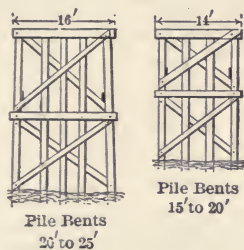
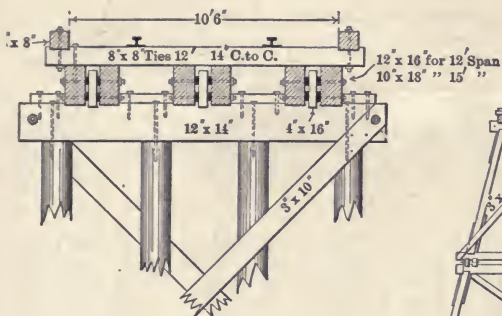

Fig. 32.

Fig. 33.

TABLE 61.—PILE TRESTLE: SINGLE TRACK APPROXIMATE QUANTITIES AND COST COMPLETE.

(Bents 12-foot centers.)

Height, bottom of sill to top of cap.	Piles.				Bracing and floor system.				
	No. per bent.	Aver- age length each.	Lineal ft. per ft. of trestle.	Cost at 30 cts. per ft.	Ft. B. M. per ft. of trestle.	Cost at \$35 per M. ft. B. M.	Iron per lin. ft. of trestle, lb.	Cost at 6 cts. per lb.	Approxi- mate total cost per lineal ft. of trestle.
5	4	20	7	\$2.10	220	\$7.70	20	\$1.20	\$11.00
10	4	25	9	2.70	230	8.05	22	1.32	12.00
15	4	30	10	3.00	240	8.40	24	1.44	12.84
20	4	35	12	3.60	250	8.75	26	1.56	13.91
25	5	40	17	5.10	260	9.10	28	1.60	15.88
30	5	45	19	5.70	270	9.45	30	1.80	16.95

Rails and fastenings not included.

TABLE 62.—PILE TRESTLE: SINGLE TRACK. (Fig. 32.) APPROXIMATE QUANTITIES AND COST COMPLETE.

(Bents 15-foot centers.)

Height, bottom of sill to top of cap.	Piles.				Bracing and floor system.				
	No. per bent.	Aver- age length each.	Lineal ft. per ft. of trestle.	Cost at 30 cts. per ft.	Ft. B. M. per ft. of trestle.	Cost at \$35 per M. ft. B. M.	Iron per lin. ft. of trestle, lb.	Cost at 6 cts. per lb.	Approxi- mate total cost per lineal ft. of trestle.
5	4	20	7	\$2.10	200	\$7.00	18	\$0.00	\$10.00
10	4	25	9	2.70	210	7.35	20	1.00	11.05
15	4	30	10	3.00	220	7.70	22	1.10	11.80
20	4	35	12	3.60	230	8.05	24	1.20	12.25
25	5	40	17	5.10	240	8.40	26	1.30	14.80
30	5	45	19	5.70	250	8.75	28	1.40	15.85

Rails and fastenings not included



TABLE 63.—FRAME TRESTLE: SINGLE TRACK. (Fig. 33.) APPROXIMATE QUANTITIES AND COST.

BENTS, BRACINGS, SILLS, CAPS, STRINGERS, AND FLOOR SYSTEM.

(Bents 15-foot centers.)

Height, base of rail to bottom of sill.	Ft. B. M. per lineal ft. of trestle.	Cost at \$35 per M. ft. B. M.	Iron per ft. of trestle, lb.	Cost at 5 cts. per lb.	Total cost per lineal ft. of trestle.
Ft.					
20	300	\$10.50	20	\$1.00	\$11.50
25	350	12.25	20	1.00	13.50
30	400	14.00	20	1.00	15.00
35	450	15.75	22	1.10	16.85
40	500	17.50	24	1.20	17.70
45	550	19.25	26	1.30	20.55
50	600	21.00	28	1.40	22.40
55	650	22.75	30	1.50	24.25
60	700	24.50	32	1.60	26.10
65	750	26.25	34	1.70	27.95
70	800	28.00	36	1.80	29.80
75	900	31.50	38	1.90	33.40
80	950	33.25	40	2.00	35.25
85	1000	35.00	42	2.10	37.10
90	1050	36.75	44	2.20	38.95
95	1100	38.50	46	2.30	40.80
100	1150	40.25	48	2.40	42.65

Pile foundation extra. Masonry foundation extra.

Rails and fastenings not included.

**Ballasted Floors.**—Where on account of difficulty of obtaining a good foundation or procuring material for a permanent structure except at a prohibitive cost, the use of wooden trestle bridge with ballasted floors is sometimes the best alternative between the costly permanent structure or the common wooden trestle with open deck.

There are two types of floor construction for ballast floor wooden trestles in general use, one having the stringers placed so as to form a solid floor, Fig. 34, and the other having the stringers separated and covered with plank, Figs. 35 and 36.

Usually all the timbers in the construction of the ballast floor are treated by creosote or other process.

The estimated life of these bridges varies from twenty to twenty-five years when treated, without repairs of any consequence.

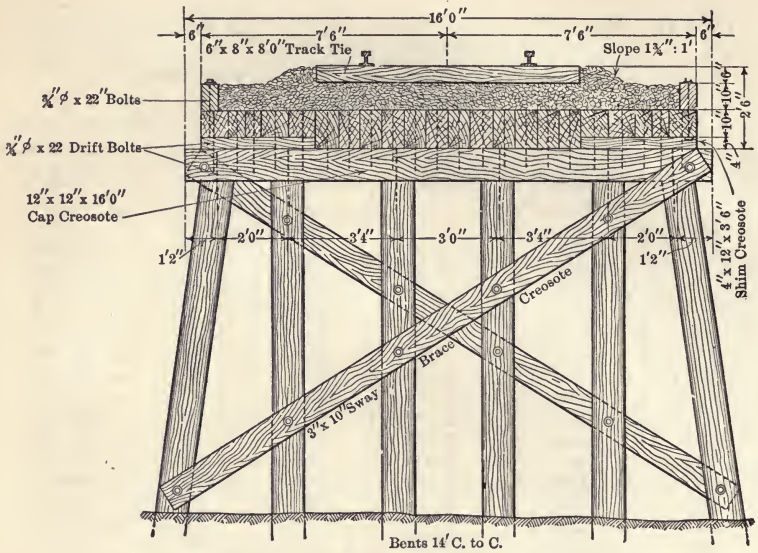

Fig. 34. Ballasted Floor Trestle, H. T. & S. Fé. Ry.

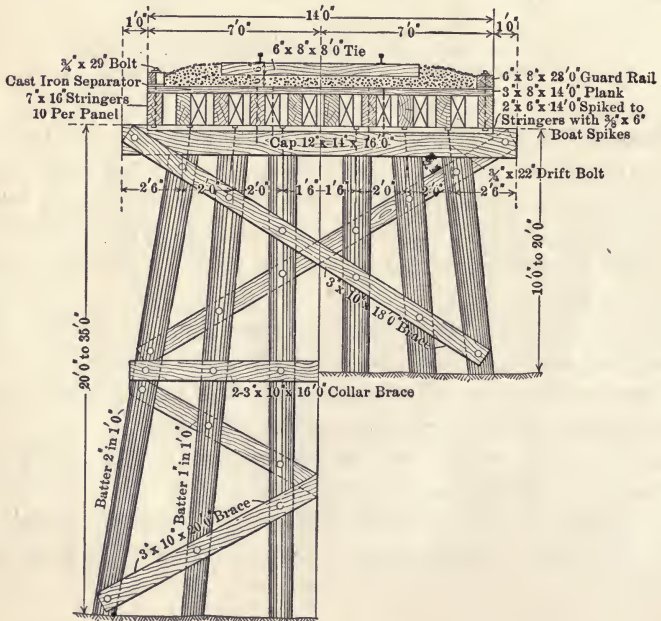

Fig. 35. Ballast Floor Trestle, Ill. Cent. R.R.



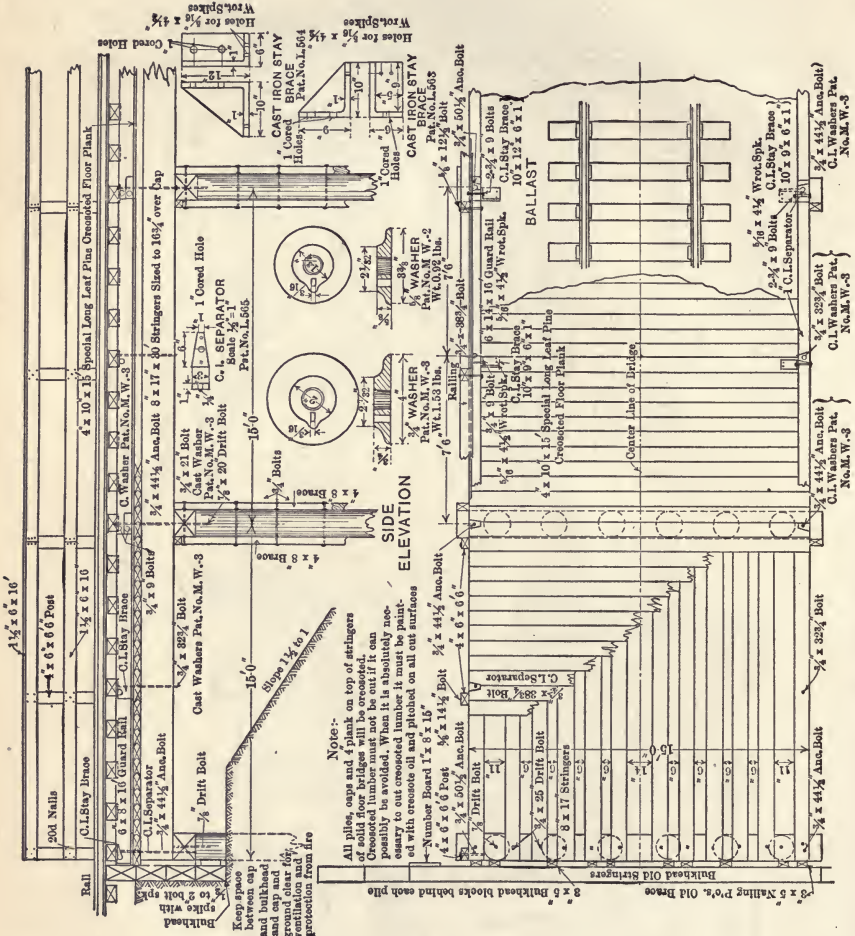

Fig. 36 (Continued). Pile and Trestle Bridges.

Fig. 36 illustrates the ballasted floor for pile and trestle bridges as adopted by the Union Pacific Railroad, with bents 15 ft. centers, six piles or posts to the bent.

**Ballasted-Deck Pile Trestle, Kansas City S. Ry.** — The trestle design, Fig. 36a, is a good example of modern practice in this type of structure, described in *Eng. News*, Jan. 16, 1916. Bents over 22 ft. in height have horizontal sash braces 11 ft. apart with swaybracing between them. Upon the sash braces are bolted girts or horizontal longitudinal timbers. Diagonal longitudinal braces are fitted in each panel, except in those bottom panels where they might form an obstruction to the free passage of drift.

The end bent has five piles, and back of the cap and stringers are three 6 × 10-in. header planks to hold the end of the roadbed. In trestles having an odd number of panels, one end panel has all its stringers 15 ft. long.

The caps and stringers are sized to 12 × 13 $\frac{3}{4}$  in. and 8 × 15 $\frac{3}{4}$  in. before creosoting. The treated timbers are handled so as to obviate cutting as far as possible, but where they have been cut in framing, the fresh surfaces are given three coats of hot creosote oil. Boltholes bored through are filled with the oil, and the bolts are coated with creosote before being placed. If the hole is not used it is closed with creosoted plugs (after the oil filling). Where spikes are removed, the holes are filled with oil and plugged in the same way.

The ends of the deck stringers are lapped on the caps, except that the outside stringers are fitted together over alternate caps. The amount of gravel required for ballast is about 0.233 cu. yd. per lin. ft. of trestle.

Concrete trestles are of two types — one having concrete pile bents and caps and the other having thin concrete piers to carry the slabs forming the spans, Fig. 37.

The latter type of construction on the Kansas City Southern Ry., near Anderson, Mo., is shown. The bridge has eight spans of 12 $\frac{1}{2}$  ft. in the clear (between piers), with a headway of 5 to 10 ft. It carries the ordinary ballasted track construction and the following description on page 135 is from the *Engineering News* of Feb. 3, 1916, including the illustrations on page 136 showing the structure and the details of the floor slabs, piers and abutments.

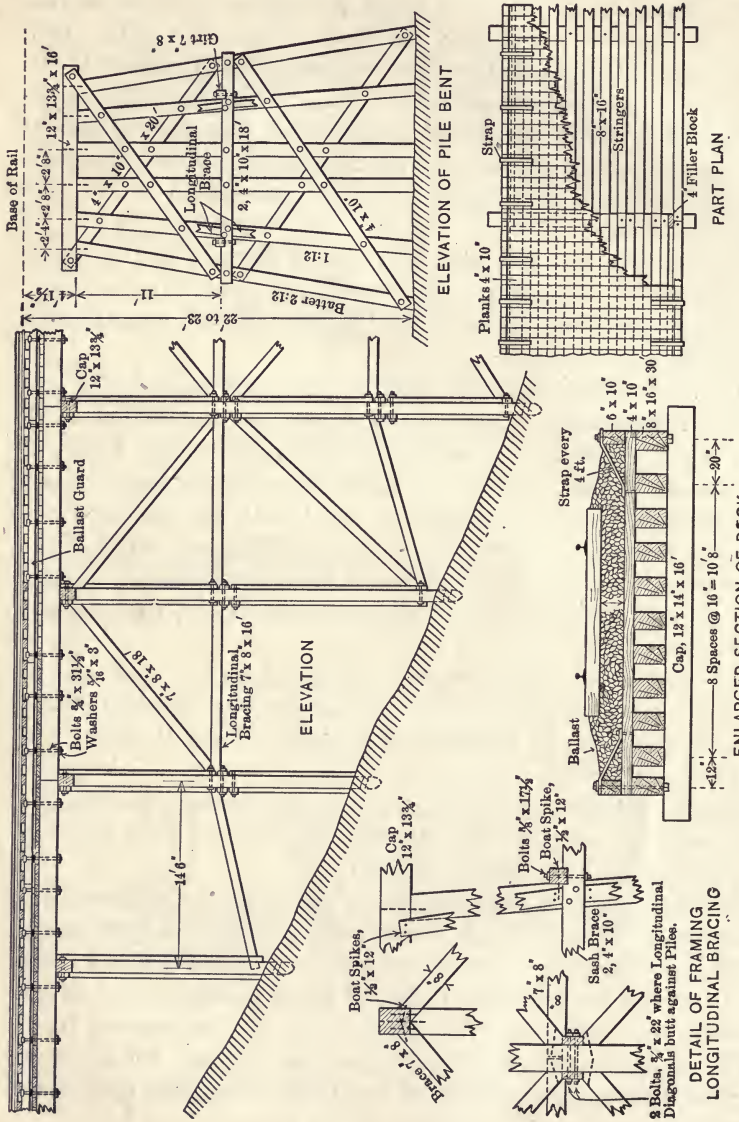

Fig. 36a. Pile Trestle, Ballasted Deck, K. C. S. Ry.

**Piers and Abutments.** — The piers are of reinforced concrete, 30 in. thick, with broad footings, no foundation piles being used. The concrete is proportioned 1 : 2 : 4, and the reinforcement consists of square twisted bars of medium openhearth steel, arranged as shown. The abutments are of open box form, with end wall, bottom and side walls parallel with the track. They are embedded in the end of the fill. The concrete for the abutments is proportioned 1 : 3 : 5 and is not reinforced.

The top of each pier and the bridge seat of each abutment have two dowels  $1\frac{1}{4} \times 10$  in. which enter  $1\frac{3}{4}$ -in. holes in the slab and prevent the latter from creeping. The tops of the piers and the bridge seats of the abutments are finished to an elevation  $\frac{3}{4}$  in. below the bottom of the slabs. When the slabs are being set in place, this space is filled with cement mortar and a zinc plate  $\frac{1}{2}$  in. thick is placed between the mortar joint and the slab, this plate extending over the full area of the bearing surface.

**Concrete-slab Superstructure.** — The deck, or superstructure, consists of a double row of concrete slabs, which are cast at a convenient place and set in position by derrick cars when the piers are completed. Each slab is  $14\frac{1}{2}$  ft. long and 7 ft. wide, with a curb wall along one side, so that the two slabs form a trough to contain the ballast. The minimum thickness is  $23\frac{1}{2}$  in., at the inner side, where grooves in the faces of the slabs form vertical drain holes.

The concrete for the slabs is mixed 1 : 2 : 4. The steel reinforcement consists of longitudinal square twisted bars (having the ends bent as shown), with transverse bars, and vertical transverse stirrups looped under the horizontal bars. For hoisting, each slab has two stirrups, or shackles, set at an angle of 60 degrees, the top of the concrete having a pocket around the projecting loop.

The slabs are set with their ends  $\frac{1}{2}$  in. apart, the spaces being filled with asphaltum or some bituminous paving composition. Each slab contains  $8\frac{1}{3}$  cu. yd. of concrete and 1115 lb. of reinforcing steel. The total estimated weight, including 60 lb. for the hoisting stirrups, is 34,000 lb.

Gravel ballast is filled to a depth of 18 in. below the tops of the ties, the rails being above the level of the curb walls.

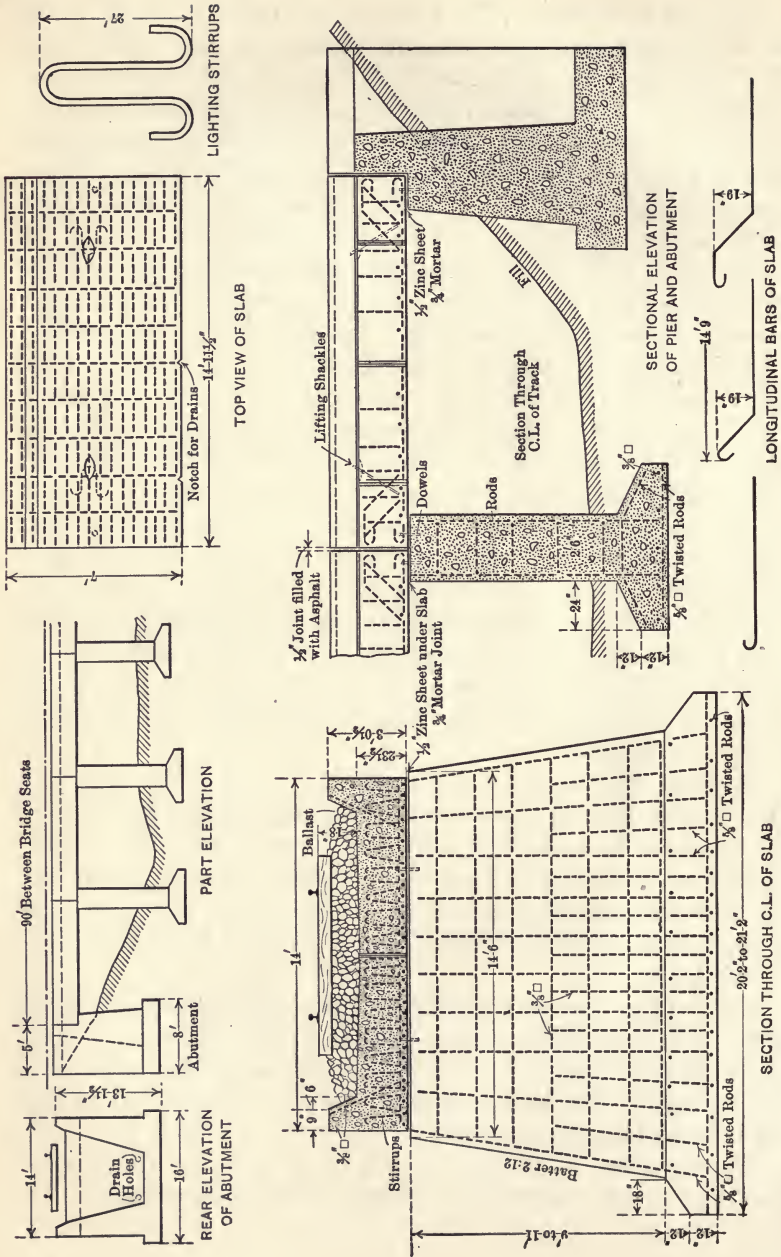

Fig. 37. Kansas City S. Ry. Concrete Trestle.



**CULVERTS.**

Culverts are used for conveying small streams under the road-bed and for drainage purposes. Tile, concrete, corrugated and cast-iron pipes are principally used, including masonry and timber boxes and concrete arches.

When pipes are used locate on solid ground high enough to clear when flow ceases, and lay on a uniform grade equal to that of the natural ground, with a camber when grade is less than one per cent to prevent formation of pockets by settlement. Preferably excavate trench to fit the bottom part; otherwise solidify by tamping and compacting carefully around the culvert.

Do not block, wedge, or lay in water. Place all sockets up-grade and begin from lower end.

When two or more are used side by side keep them one diameter apart.

When there is a liability to scour, end walls or sheet piling is provided.

When pile foundation is necessary use one row for small pipes and two rows staggered, for 24 inch or greater, supporting the entire length of pipe. Box or arch culverts are piled when necessary under the main walls.

In placing concrete pipe culverts under earth embankments over 30 ft. high, it will usually be found most economical to open up a trench at each end, to a depth of about 15 ft. and tunnel through the remaining distance.

**Estimating Sizes of Pipe.** — One-inch rainfall per acre gives approximately 24,000 gallons per hour, or 400 gallons per minute. Not more than 50 per cent to 75 per cent will reach drain within same hour.

APPROXIMATE CARRYING CAPACITY OF PIPES.

(Inches fall to 100 feet.)

Size of pipe.	2 in.	3 in.	6 in.	9 in.	12 in.	24 in.	36 in.
	Gallons discharged per minute.						
18 inches . . .	2,000	2,500	3,500	4,500	5,000	7,000	8,500
24 inches . . .	4,500	5,500	7,500	9,000	10,500	15,000	18,000
30 inches . . .	8,000	9,500	13,500	16,500	19,000	26,500	32,500
36 inches . . .	12,500	15,500	22,000	26,500	31,000	43,500	53,000

Make allowance for severe storms, which are generally of short duration.

**Tile Pipe Culverts.** (Fig. 38.)— Tile pipe must have at least 4 feet of embankment on top.

TABLE 64.— APPROXIMATE COST.

Inner diam.	Min. thick-ness shell.	Min. length laid.	Depth of socket.	Annular space.	Weight per lin. ft.	Approx. cost per ft.	Rip-rap walls for ends when re-quired (Fig. 38), cu. yd.
In.	In.	In.	In.	In.	Lb.		
4	$\frac{1}{2}$	24	2	$\frac{1}{2}$	10	\$0.10	.....
6	$\frac{5}{8}$	24	$2\frac{1}{2}$	$\frac{3}{8}$	16	0.13 $\frac{1}{2}$	.....
8	$\frac{3}{4}$	30	$2\frac{3}{4}$	$\frac{1}{2}$	25	0.17 $\frac{1}{2}$	.....
10	$\frac{7}{8}$	30	$2\frac{3}{4}$	$\frac{5}{8}$	37	0.22	.....
12	1	30	3	$\frac{3}{4}$	45	0.27	8
15	$1\frac{1}{4}$	30	3	$\frac{7}{8}$	76	0.46	9
18	$1\frac{1}{2}$	30	$3\frac{1}{4}$	1	118	0.63	10
20	$1\frac{2}{3}$	30	$3\frac{1}{2}$	$1\frac{1}{8}$	138	1.10	11
24	2	30	4	$1\frac{1}{4}$	190	1.37	12

Excavating, laying, and refilling extra.

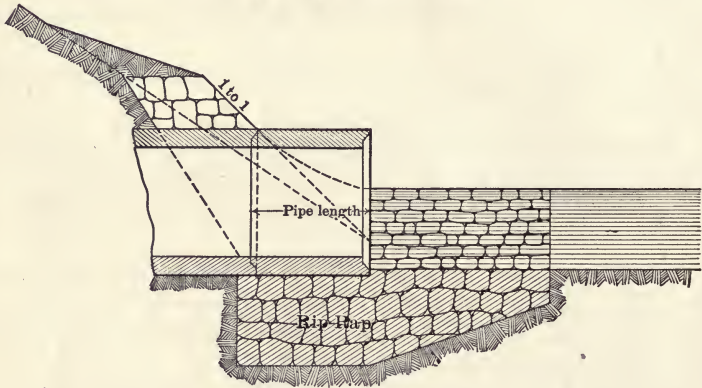

CROSS SECTION

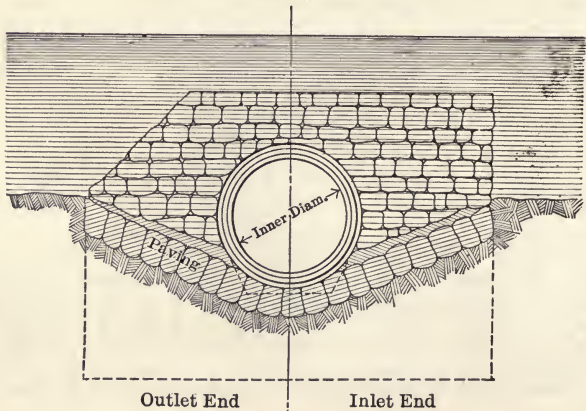

PIPE CULVERTS

Fig. 38.

**Concrete Pipe.** — The great expense in placing concrete pipes in embankments and the question of repairs in case of failure calls for some discretion in their use. The pipe should be of the best quality, very dense and impervious to water as much as possible; any veins or seams that will pass water will cause disturbance later when laid.

Careful attention must be given the foundation; the pipes before being laid should be carefully examined to avoid placing cracked or defective ones in the culvert. End walls and end of pipes should be carried down far enough to be protected from frost. In laying pipes, where a solid even bed could not be obtained, old 2" planks have been used to provide a bed and old ties where the foundation is soft.

Concrete pipe may fail under the track in fills under 6 ft. high from base of rail to top of pipe, and in fills over 14 ft. high; between 6 ft. and 14 ft. the concrete pipe is satisfactory. Triangular concrete pipe seldom fails, and should be used in shallow fills under  $4\frac{1}{2}$  ft. from top of pipe to base of rail, or cast iron pipe should be used.

Where the waterway is large and two pipes may be necessary, driftwood may block up the small opening at the inlet, and concrete arch culverts in such cases are preferable.

Double pipes are sometimes used also in shallow fills; this is not recommended as a rail top culvert is much better.

For side culverts under road crossings, tile pipe or corrugated iron pipes are less expensive than concrete. The load to be carried does not warrant the more expensive concrete pipe.

The idea of limiting the depth of concrete pipe is that in case of failure pipes can be more readily replaced with less delay and expense.

In hard pan where boulders appear, it may be necessary to dress off and level up with grout or lean concrete so as to make a satisfactory bed if it will cost less than removing the boulders, filling and tamping up so as to avoid future settlement especially under heavy fills. If the depth is over ten feet probably an arch, under such circumstances, would be more economical.

Every precaution must be taken to prevent the working of water underneath the pipe which will destroy the bed and allow the pipe to settle.

TABLE 65. — APPROXIMATE COST CONCRETE PIPE PER LINEAL FOOT.  
(Mixture: 1 cement, 2 sand, and 3 broken stone.)

Inner diam. of pipe, in.	Pipe lengths, ft.	Weight in lb. at 130 per cu. ft.		Cu. ft. per lin. ft.	Thickness of pipe.	Approx. cost per lin. ft.	Rip-rap for end walls when required extra, cu. yds.
		Per lin. ft.	Per length.				
18	3.0	150	450	1.15	$2\frac{5}{8}$	\$0.50	3
24	3.0	300	900	2.3	$3\frac{1}{2}$	1.00	4
30	2.6	430	1075	3.3	$4\frac{1}{2}$	1.45	5
36	2.5	550	1375	4.25	$5\frac{7}{16}$	1.90	6

Excavating, laying, and refilling extra.

## BILL OF CULVERT PIPES REQUIRED FOR DIFFERENT HEIGHTS OF EMBANKMENTS.

24''	Ht. from base of rail to invert	6'10''	7'10''	8'10''	9'10''	10'10''	11'10''	12'10''	13'10''	14'10''
	No. lin. ft. of culvert pipe req.	30'	33'	36'	39'	42'	45'	48'	51'	54'
30''	Ht. from base of rail to invert	7' 4''	8' 4''	9' 4''	10' 4''	11' 4''	12' 4''	13' 4''	14' 4''	15' 4''
	No. lin. ft. of culvert pipe req.	30'	32' 6''	35'	40'	42' 6''	45'	47' 6''	50'	55'
36''	Ht. from base of rail to invert	8' 0''	9' 0''	10' 0''	11' 0''	12' 0''	13' 0''	14' 0''	15' 0''	16' 0''
	No. lin. ft. of culvert pipe req.	30'	32' 6''	35'	40'	42' 6''	45'	47' 6''	50'	55'
24''	Ht. from base of rail to invert	15'10''	16'10''	17'10''	18'10''	19'10''	20'10''	21'10''	22'10''	23'10''
	No. lin. ft. of culvert pipe req.	57'	60'	63'	66'	69'	72'	75'	78'	81'
30''	Ht. from base of rail to invert	16' 4''	17' 4''	18' 4''	19' 4''	20' 4''	21' 4''	22' 4''	23' 4''	24' 4''
	No. lin. ft. of culvert pipe req.	57' 6''	60'	62' 6''	65'	67' 6''	70'	72' 6''	75'	77' 6''
36''	Ht. from base of rail to invert	17' 0''	18' 0''	19' 0''	20' 0''	21' 0''	22' 0''	23' 0''	24' 0''	25' 0''
	No. lin. ft. of culvert pipe req.	57' 6''	60'	62' 6''	65'	70'	72' 6''	75'	77' 6''	80'
24''	Ht. from base of rail to invert	23'10''	24'10''	25'10''	26'10''	27'10''	28'10''	29'10''	30'10''	31'10''
	No. lin. ft. of culvert pipe req.	81'	84'	87'	90'	93'	96'	99'	102'	105'
30''	Ht. from base of rail to invert	24' 4''	25' 4''	26' 4''	27' 4''	28' 4''	29' 4''	30' 4''	31' 4''	32' 4''
	No. lin. ft. of culvert pipe req.	80'	82' 6''	85'	87' 6''	90'	92' 6''	95'	97' 6''	100'
36''	Ht. from base of rail to invert	25' 0''	26' 0''	27' 0''	28' 0''	29' 0''	30' 0''	31' 0''	32' 0''	33' 0''
	No. lin. ft. of culvert pipe req.	80'	85'	87' 6''	90'	92' 6''	95'	97' 6''	100'	102' 6''

## MATERIAL REQUIRED FOR MORTAR FOR 100 JOINTS OF PIPE.

For 24'' diam. is required 3 bbl. cement and 0.4 cu. yd. sand.

For 30'' diam. is required 4 bbl. cement and 0.5 cu. yd. sand.

For 36'' diam. is required 6 bbl. cement and 0.75 cu. yd. sand.

## BILL OF RIP-RAP AT TWO ENDS.

For 24'' pipe is required 4 cu. yd.

For 30'' pipe is required 5 cu. yd.

For 36'' pipe is required 6 cu. yd.

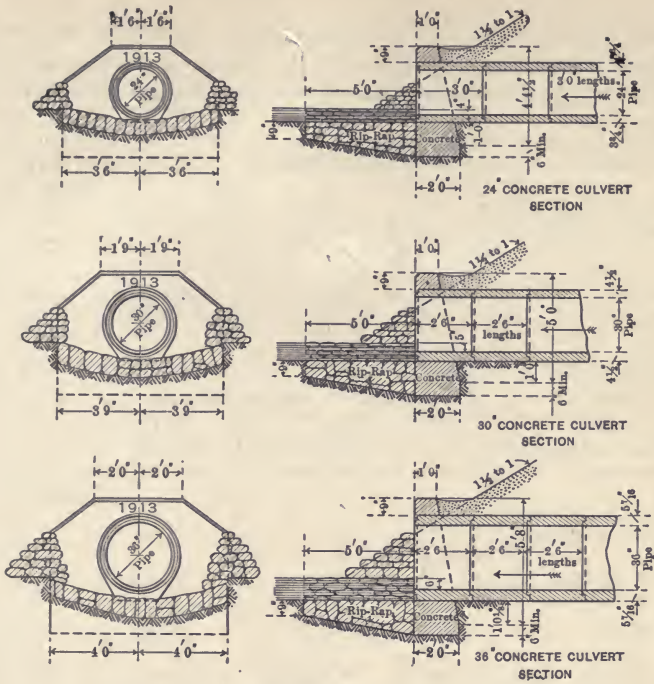
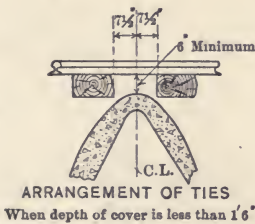

Fig. 39. C. P. R. Standard Concrete Pipe.



Triangular concrete pipes are to be used when the depth of cover is less than 4 ft. 6 in., and generally depth should not be less than 1 ft. 6 in.

In special cases, however, the pipe may be brought closer to the rail, with the arrangement of ties shown.

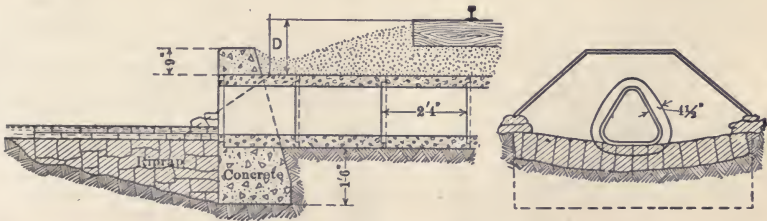

Fig. 40. C. P. R. Triangular Concrete Pipe.

TABLE 66.

COMPARATIVE COST OF INSTALLING THREE TYPES OF CULVERTS. 4½' TOP OF C. TO B. OF R.

Items.	24 tri. con. pipe.			24-in. cast-iron pipe.			2 ft. × 2 ft. wood box.		
Supporting track.....			\$55			\$55			\$55
Excavation and backfill	45 cu. yds.	\$1.00	45	40 cu. yds.	\$1.00	40	60 cu. yds.	\$1	60
Culvert material.....	32 lin. ft.	1.00	32	36 lin. ft.	38.00	171	4000 F. B. M. (\$25 M.)		100
Handling, laying, store charges and hardware			20			38			40
End walls.....	3 cu. yds.	10.00	30						
Rip-rap and paving.....			15						
Contingencies.....			23			29			25
Total cost.....			\$220			\$330			\$280

COMPARATIVE COST OF INSTALLING THREE TYPES OF CULVERTS. 20' TOP OF C. TO B. OF R.

Items.	30 in. con. pipe.			30-in. cast-iron pipe.			2 ft. × 4 ft. wood box.		
Supporting track.....			\$150			\$150			\$150
Excavation and backfill	225 cu. yds.	\$1.00	225	220 cu. yds.	\$1.00	220	250 cu. yds.	\$1	250
Culvert material.....	80 lin. ft.	1.45	116	84 lin. ft.	38.00	513	11,000 F. B. M. (\$25 M.)		280
Handling, laying, store charges and hardware			75			75			
End walls.....	5 cu. yds.	10.00	50						90
Rip-rap and paving.....			15						
Contingencies.....			61			92			70
Total cost.....			\$692			\$1050			\$840

Cast-iron Pipe Culverts. — Cast-iron pipe must have at least 10 feet of embankment and preferably not over 25 feet.

TABLE 67. — APPROXIMATE WEIGHT OF LEAD AND YARN PER JOINT.

Diam.	3 in.	4 in.	6 in.	8 in.	10 in.	12 in.	14 in.	16 in.	20 in.	24 in.
Lbs.										
Lead...	7.25	8.75	11.75	15	18	21.5	33	37.25	41.5	53.5
Yarn...	0.11	0.12	0.19	0.25	0.30	0.35	0.40	0.45	0.6	0.68

TABLE 68. — CAST-IRON PIPE, APPROXIMATE COST, ETC. Bell and spigot joint.

Size inner diam. pipe.	Length of pipe.		Weight in lbs. per		Thickness of pipe.	Cost per ft. at \$35 per ton.	Rip-rap for end walls when required. (Fig. 38.)
	Over all.	Laid.	Ft. laid.	Length.			
In.	Ft.	In.	Ft.		In.		Cu. yds.
4	12	4	12	22	7 16	\$0.39	.....
6	12	4	12	36	1 2	0.63	.....
8	12	4	12	53	9 16	0.93	.....
10	12	4	12	73	5 8	1.28	.....
12	12	4	12	95	11 16	1.66	8
14	12	5	12	119	3 4	2.09	8½
16	12	5	12	147	13 16	2.57	9
18	12	5	12	176	2 2	3.08	10
20	12	5	12	208	2 2	3.64	11
24	12	5	12	282	1	4.93	12

**Cedar Box Culverts.** (Fig. 41.) — To be used only when pipe or concrete culverts cannot be placed economically. In sand embankments use side frames as shown in dotted lines.

TABLE 69. — APPROXIMATE COST, ETC.

Size.	Kind.	Ft. B.M. per ft.	Cost at \$30 per M.	Paving, sq. yd. per ft.	Cost at \$2 per sq. yd.	Iron, lbs. per ft.	Cost at 5 cts. per lb.	Approx. cost per ft. complete.
2 × 4	Single	90	\$2.70	0.5	\$1.00	6	30	\$4.00
2 × 4	Double	150	4.50	1.0	2.00	10	50	7.00
4 × 4	Single	175	5.25	0.5	1.00	15	75	7.00
4 × 4	Double	275	8.25	1.0	2.00	20	180	11.25

Sheet pile at ends when scouring is likely to occur.  
Excavating and refilling extra.

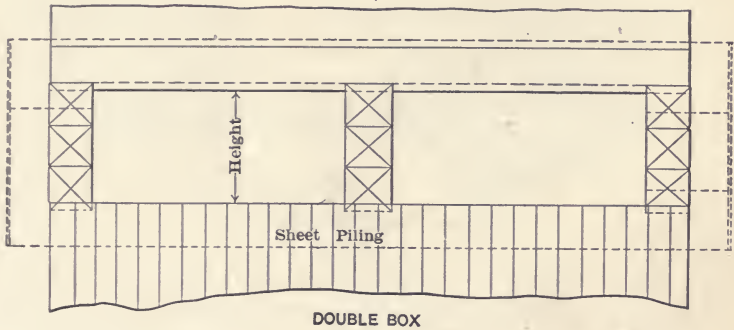

DOUBLE BOX

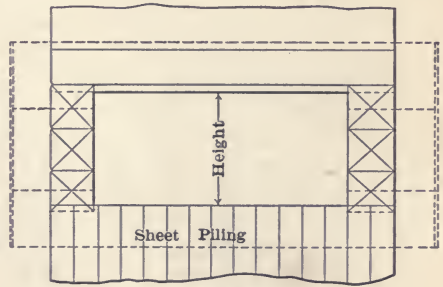
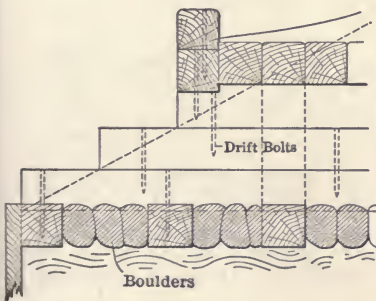

SINGLE BOX

Fig. 41. Wood Box Culverts.

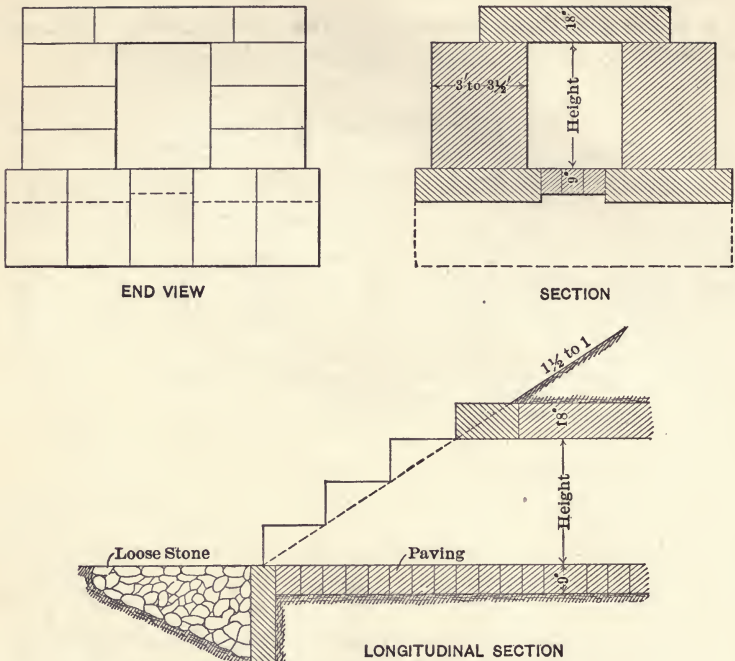

Fig. 42. Stone Box Culverts.

TABLE 70. — APPROXIMATE COST, ETC.

MATERIAL: RUBBLE MASONRY, IN CEMENT MORTAR.

Body.		Paving.		Total cost per lin. ft.	Add for 2 end wing walls.					
Size.	Cu. yd. per lin. ft.	Cost at \$8 per cu. yd.	Sq. yd. per lin. ft.		Cost at \$1.50.	Cu. yds.	Cost at \$8.	Rip-rap, cu. yds.	Cost at \$2 per yd.	Total cost for 2 end walls, etc.
Ft.				Cts.						
3 × 3	1.10	\$8.80	0.30	45	\$9.25	7	\$56.00	8.00	\$24.00	\$88.00
3 × 4	1.50	12.00	0.30	45	12.45	12	96.00	9.00	27.50	123.00
4 × 4	1.75	14.00	0.40	60	14.60	12	96.00	10.00	30.00	126.00
4 × 5	2.0	16.00	0.50	75	16.75	19	152.00	12.00	36.00	188.00
5 × 5	2.25	18.00	0.50	75	18.75	19	152.00	12.00	36.00	188.00
5 × 6	2.5	20.00	0.60	90	20.90	27	216.00	14.00	42.00	258.00

Excavating and refilling extra.



**Rail Concrete Culverts.** — For permanent structures where there is insufficient head-room for culvert pipes or concrete arch culverts, rail concrete culverts are used. Figs. 43, 44, 45 and 46.

The spans given are from 4 to 10 feet, the arrangement consisting of concrete retaining walls, sloped with the bank, with concrete reinforced floor over, 10 to 12 inches thick, the reinforcement being old rails embedded in the concrete at about 12-inch centers. The floor is paved with field stones, and the ends of walls rip-rapped when necessary, or concrete is used for floor and end walls, either plain or reinforced.

SINGLE RAIL CONCRETE CULVERTS

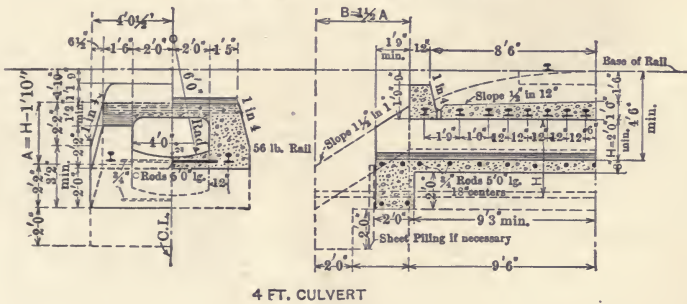

4 FT. CULVERT

Fig. 43.

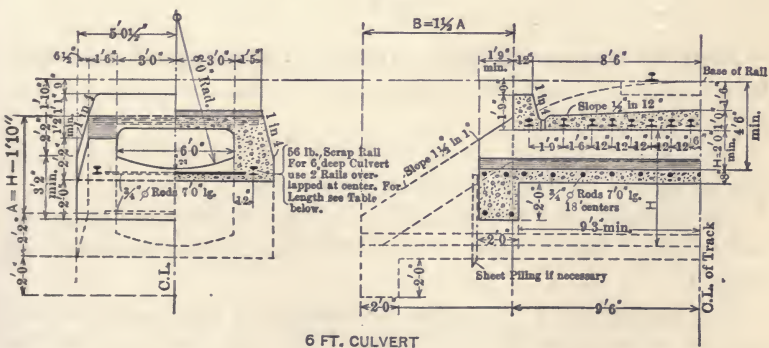

6 FT. CULVERT

Fig. 44.

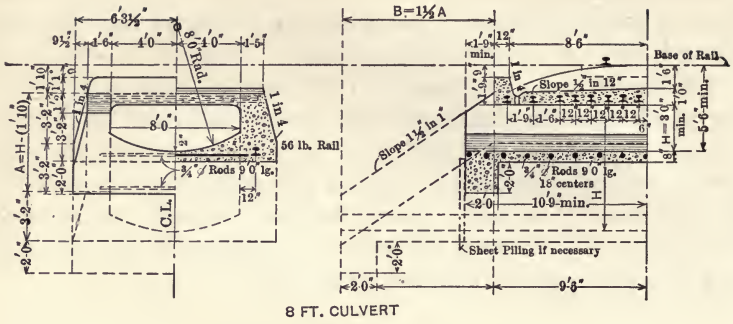

8 FT. CULVERT  
Fig. 45.

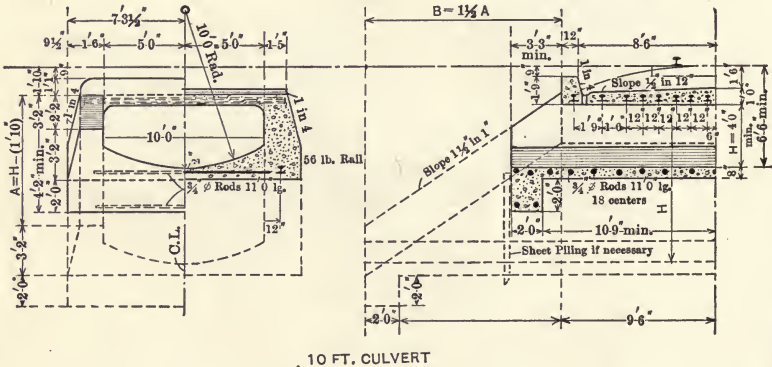

10 FT. CULVERT  
Fig. 46.

**Single-rail Concrete Culverts.** — These culverts to be used only where there is insufficient head room for culvert pipes or concrete arch culverts.

The culverts should not be loaded before the concrete has set, the minimum time allowed being two weeks.

The quantity and arrangement of rip-rap at ends may be modified by the division engineer to suit the varying conditions of the ground.

The ingredients for concrete will consist of one part Portland cement, three parts of clean sharp sand and five parts broken stone.

Rails shown are 56 lb. scrap rails, but any heavier suitable section may be used.

Single-Rail Concrete Culverts (Figs. 43, 44, 45 and 46).

TABLE 71. — BILL OF MATERIAL.

4-ft. culvert.						6-ft. culvert.							
H. in ft.	Con-crete.	Old scrap rails at 56 lb.			Reinforcing bars.		H. in ft.	Con-crete.	Old scrap rails at 56 lb.			Reinforcing bars.	
		No.	L'gth.	Wt. in lb.	No.	Wt. in lb.			No.	L'gth.	Wt. in lb.	No.	Wt. in lb.
	Cu. yd.		Ft. In.				Cu. yd.		Ft. In.				
2	17.3	16 2	6 6 22 0	2760	21	160	2	20.8	16 2	8 6 22 0	3360	21	220
3	22.8	16 2	6 6 25 0	2880	23	170	3	25.8	16 2	8 6 25 0	3480	23	240
4	28.3	16 2	6 6 28 0	3000	25	190	4	31.8	16 2	8 6 28 0	3600	25	260
...	.....	...	.....	.....	...	.....	5	37.8	16 2	8 6 31 0	3720	27	280
...	.....	...	.....	.....	...	.....	6	43.8	16 4	8 6 19 0	3980	29	300
8-ft. culvert.						10-ft. culvert.							
H. in ft.	Con-crete.	Old scrap rails at 56 lb.			Reinforcing bars.		H. in ft.	Con-crete.	Old scrap rails at 56 lb.			Reinforcing bars.	
		No.	L'gth.	Wt. in lb.	No.	Wt. in lb.			No.	L'gth.	Wt. in lb.	No.	Wt. in lb.
	Cu. yd.		Ft. In.				Cu. yd.		Ft. In.				
3	30.0	16 2	10 6 22 0	3960	21	280	4	41.2	16 2	12 6 25 0	4700	23	380
4	36.5	16 2	10 6 25 0	4070	23	310	5	48.7	16 2	12 6 28 0	4800	25	410
5	43.3	16 2	10 6 28 0	4200	25	340	6	56.6	19 2	12 6 31 0	4900	27	450
6	50.0	16 2	10 6 31 0	4320	27	370	7	64.8	16 4	12 6 19 0	5150	29	480
7	57.6	16 4	10 6 19 0	4520	29	390	8	73.4	16 4	12 6 21 6	5350	31	510
8	66.0	16 4	10 6 21 6	4750	31	420	9	82.4	16 4	12 6 23 0	5450	33	550
...	.....	...	.....	.....	.....	.....	10	92.2	16 4	12 6 24 6	5550	35	580

H = the clear height of the culvert on the center line; for example, for the 8-ft. culvert shown, Fig. 45, the height is 3 ft. and the quantities for this height from Table 71 are as follows:

- 30 cu. yds. concrete.
- 3960 lbs. old scrap rail.
- 280 lbs. reinforcing bars.

**Double-Rail Concrete Culverts.** — These double culverts are to be used where the headway is too limited for a single span, and where there is no objection to a center wall. (Figs. 47 and 48.)

The culvert should not be loaded before the concrete has set, the minimum time allowed being two weeks.

The quantity and arrangement of rip-rap at ends may be modified by the division engineer to suit the varying conditions of the ground.

The ingredients for concrete will consist of 1 part Portland cement, three parts of clean sharp sand, and five parts broken stone. (1 : 3 : 5.)

Rails shown are 56-lb. scrap rails, but any heavier suitable section may be used.

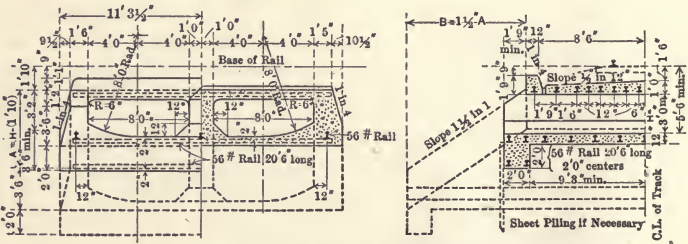

8 FT. DOUBLE CULVERT  
Fig. 47.

BILL OF MATERIAL.

8 FT. DOUBLE CULVERT, FIG. 47.

Height in feet.	Concrete, cu. yds.	Old scrap rails.		
		Number.	Length.	Weight, lbs.
3	56.2	33	20' 6"	13,880
		1	22' 0"	
4	65.9	34	20' 6"	14,340
		1	25' 0"	
5	75.8	36	20' 6"	15,230
		1	28' 0"	
6	85.6	37	20' 6"	15,736
		1	31' 0"	
7	96.4	39	20' 6"	16,744
		1	19' 0"	
8	107.9	40	20' 6"	17,290
		5	21' 6"	

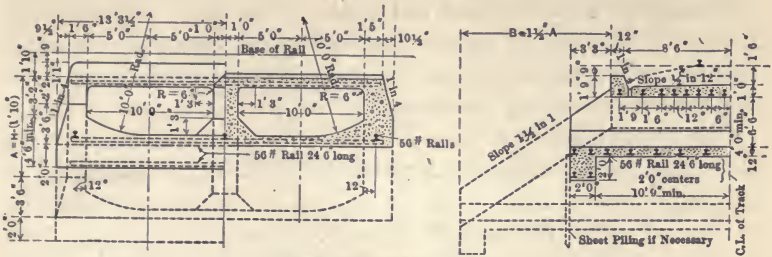

10 FT. DOUBLE CULVERT

Fig. 48.

C. P. R. Standard Concrete Rail Culverts.

BILL OF MATERIAL.

10 FT. DOUBLE CULVERT, FIG. 48.

Height in ft.	Concrete, cu. yds.	Old scrap rails.		
		Number.	Length.	Weight, lb.
4	75.2	34	24' 6"	16,856
		1	25' 0"	
5	86.2	36	24' 6"	17,920
		1	28' 0"	
6	97.5	37	24' 6"	18,480
		1	31' 0"	
7	109.1	39	24' 6"	19,656
		1	19' 0"	
8	121.1	40	24' 6"	20,272
		5	21' 6"	
9	133.5	42	24' 6"	21,336
		1	23' 0"	
10	146.7	47	24' 6"	21,896
		1	21' 6"	

Height in feet refers to the clear opening of the culvert on the center line, for example, Fig. 47, for the 8-ft. double culvert the height is 3 ft. and the quantities from the table are as follows:

56.2 cu. yds. concrete.  
13,880 lbs. old scrap rail.

**Reinforced Concrete Box Culverts.** (Fig. 49.) — Double box culverts are used in all cases where the span is equal to or greater than twice the height; the use of single box culverts beyond these proportions materially increases the cost.

The top and bottom slabs are made the same thickness with transverse reinforcement near the inner face and longitudinal shrinkage rods  $\frac{1}{2}$ -inch diameter spaced at 2-foot centers, just above and below the transverse bars. The side walls are reinforced in a similar manner near the inner face. Forty-five degree fillets are placed at all corners. The bottom slab extends for a distance equivalent to one-half of the height at each end and terminates in a baffle wall 1 foot thick and extending at least 3 feet below the bottom of slab at the downstream end and 2 feet at the upstream. The side walls extend to the ends of bottom slab and are cut off at a slope of  $1\frac{1}{2}$  to 1. The cover slabs have a curb 4 inches high at each end equal in width to thickness of cover slab. The length of the cover slabs are in general made equal to three times the depth of fill plus 18 feet for single track. All square corners have a bevel of 1 inch. The slopes of culvert bottoms are made not less than 1 per cent. :

The table is for values of "W" (the average depth of fill) not greater than 10 feet. For values of "W" greater than 10 feet the top, bottom and side walls are increased as follows:

- 1 inch when W equals 10 feet to 20 feet.
- 2 inches when W equals 20 feet to 30 feet.
- 3 inches when W equals 30 feet to 40 feet.
- 4 inches in all cases when W is greater than 40 feet.

The same size, length and spacing of bars are used for all values of "W," the extra strength required being furnished by the increased thickness of slabs.

#### NOTES.

1. Unless special permission is obtained double box culverts will be used in all cases where span is equal to or greater than twice the height. Use of single box culverts beyond these proportions materially increases the cost.

2. Use plain round rods for reinforcements.

3. Place surface rods  $1\frac{1}{4}$  in. from surface of concrete.

4. Use concrete with the following formula: 1 cement,  $2\frac{1}{2}$  sand, 5 crushed rock (or gravel). Particles of crushed rock or gravel shall not exceed 1 in. in any dimension.

5. Distance from base of rail to top of concrete shall be not less than 12 in.

6. For values of W greater than 10 ft. increase the thickness of top, bottom and

side walls as follows: 1 in. when W equals 10 to 20 ft.; 2 in. when W equals 20 to 30 ft.; 3 in. when W equals 30 to 40 ft.; 4 in. when W is greater than 40 ft. Use same size, length and spacing of rods for all values of W.

7. Where piles are necessary an approved special plan shall be used.

8. Slope of culvert shall be not less than 1.0 per cent.

9. Bevel all square corners 1 in.

10. Where special conditions render departure from the standard advisable the desired changes must be indicated in crayon on a blue print and submitted to the Chief Engineer Maintenance of Way for approval prior to the commencement of work.

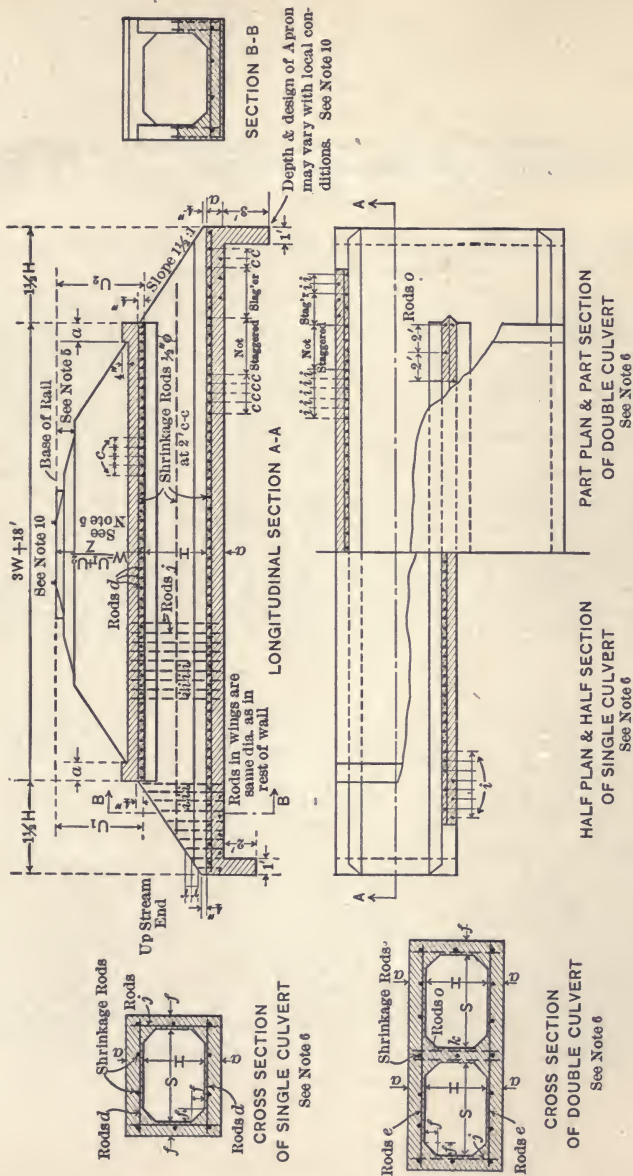

Fig. 49. Reinforced Concrete Box Culverts.

TABLE 72. — TABLE OF QUANTITIES AND DIMENSIONS FOR SINGLE AND DOUBLE BOX CULVERTS.

(Fig. 49.)

QUANTITIES AND DIMENSIONS FOR SINGLE AND DOUBLE BOX CULVERTS FOR VALUES OF "W" NOT GREATER THAN 10 FT. (See Note 6.)

Dimensions.	Height inside (feet) . . . . .	H	3	3	3	3	3	3	3	3	3	4	4
	Clear span (feet) . . . . .	S	3	4	5	6	8	10	12	14	14	3	4
	Top & bottom	Thickness (in.) . . . . .	a	6	8	10	12	15	18	20	22	6	8
		Dia. of rods (in.) . . . . .	b	$\frac{3}{8}$	$\frac{3}{8}$	$\frac{7}{8}$	$\frac{7}{8}$	1	1	1	1	$\frac{3}{4}$	$\frac{3}{4}$
		Spacing of rods (in.) . . . . .	c	6 $\frac{1}{2}$	7	7 $\frac{1}{2}$	6 $\frac{1}{2}$	6 $\frac{1}{2}$	5 $\frac{1}{2}$	5	4 $\frac{1}{2}$	9 $\frac{1}{2}$	7
		Length of rods, single culvert . . . . .	d	3' 10"	5'	6' 2"	7' 4"	9' 8"	12'	14' 4"	16' 8"	4' 2"	5' 2"
		Length of rods, double culvert . . . . .	e	7' 4"	9' 7"	11' 10"	14' 1"	18' 7"	23' 1"	27' 7"	32' 1"	7' 10"	9' 10"
	Side walls.	Thickness (in.) . . . . .	f	6	7	8	9	11	13	15	17	8	8
		Dia. of rods (in.) . . . . .	g	$\frac{3}{8}$	$\frac{3}{8}$	$\frac{7}{8}$	1	1	1	1	1	$\frac{3}{4}$	$\frac{3}{4}$
		Spacing of rods (in.) . . . . .	i	6 $\frac{1}{2}$	10	15	16	24	24	24	24	7	7
		Length of rods . . . . .	j	3' 10"	4' 2"	4' 6"	4' 10"	5' 4"	5' 10"	6' 2"	6' 6"	4' 10"	5' 2"
	Center wall.	Thickness (in.) . . . . .	k	6	7	8	9	11	13	15	17	8	8
		Dia. of rods (in.) . . . . .	l	$\frac{3}{8}$	$\frac{3}{8}$	$\frac{7}{8}$	$\frac{7}{8}$	$\frac{1}{2}$	$\frac{3}{8}$	$\frac{3}{8}$	$\frac{3}{4}$	$\frac{3}{4}$	$\frac{3}{4}$
		Spacing of rods (in.) . . . . .	m	24	24	24	24	24	24	24	24	24	24
Length of rods . . . . .		o	3' 10"	4' 2"	4' 6"	4' 10"	5' 4"	5' 10"	6' 2"	6' 6"	4' 10"	5' 2"	
Wing walls.	Shortest rod . . . . .	p	0' 10"	1'	1' 3"	1' 5"	1' 7"	1' 10"	2'	2' 2"	0' 10"	1' 0"	
	Dif. between rods (in.) . . . . .	r	4	6	10	11	16	16	16	16	4 $\frac{1}{2}$	4 $\frac{1}{2}$	
	Longest rod . . . . .	t	3' 6"	3' 6"	3' 9"	....	4' 3"	4' 6"	4' 8"	4' 10"	4' 7"	4' 9"	

Dimensions.	Height inside (feet) . . . . .	H	4	4	4	4	4	5	5	5	5	5	
	Clear span (feet) . . . . .	S	5	6	8	10	12	14	4	5	6	8	
	Top & bottom	Thickness (in.) . . . . .	a	10	12	15	18	20	22	8	10	12	15
		Dia. of rods (in.) . . . . .	b	$\frac{3}{8}$	$\frac{3}{8}$	1	1	1	1	$\frac{7}{8}$	$\frac{7}{8}$	$\frac{7}{8}$	1
		Spacing of rods (in.) . . . . .	c	7 $\frac{1}{2}$	6 $\frac{1}{2}$	6 $\frac{1}{2}$	5 $\frac{1}{2}$	5	4 $\frac{1}{2}$	9 $\frac{1}{2}$	7 $\frac{1}{2}$	6 $\frac{1}{2}$	6 $\frac{1}{2}$
		Length of rods, single culvert . . . . .	d	6' 4"	7' 6"	9' 10"	12' 2"	14' 6"	16' 10"	5' 6"	6' 6"	7' 8"	9' 10"
		Length of rods, double culvert . . . . .	e	12' 1"	14' 4"	18' 10"	23' 4"	27' 10"	32' 4"	10' 4"	12' 4"	14' 7"	18' 10"
	Side walls.	Thickness (in.) . . . . .	f	9	10	12	14	16	18	10	10	11	12
		Dia. of rods (in.) . . . . .	g	$\frac{3}{8}$	$\frac{3}{8}$	1	1	1	1	$\frac{7}{8}$	$\frac{7}{8}$	$\frac{7}{8}$	1
		Spacing of rods (in.) . . . . .	i	10	11	16	18	20	22	7 $\frac{1}{2}$	7 $\frac{1}{2}$	8	10
		Length of rods . . . . .	j	5' 6"	5' 10"	6' 4"	6' 10"	7' 2"	7' 6"	6' 2"	6' 6"	6' 10"	7' 4"
	Center wall.	Thickness (in.) . . . . .	k	9	10	12	14	16	18	10	10	11	12
		Dia. of rods (in.) . . . . .	l	$\frac{3}{8}$	$\frac{3}{8}$	$\frac{1}{2}$	$\frac{1}{2}$	$\frac{1}{2}$	$\frac{1}{2}$	$\frac{1}{2}$	$\frac{3}{8}$	$\frac{3}{8}$	$\frac{3}{8}$
		Spacing of rods (in.) . . . . .	m	24	24	24	24	24	24	24	24	24	24
Length of rods . . . . .		o	5' 6"	5' 10"	6' 4"	6' 10"	7' 2"	7' 6"	6' 2"	6' 6"	6' 10"	7' 4"	
Wing walls.	Shortest rod . . . . .	p	1' 3"	1' 4"	1' 8"	1' 10"	2'	2' 2"	1' 1"	1' 3"	1' 5"	1' 7"	
	Dif. betw. rods (in.) . . . . .	r	6 $\frac{1}{2}$	7 $\frac{1}{2}$	11	12	13	15	5	5	5	7	
	Longest rod . . . . .	t	4' 6"	5' 1"	5' 4"	4' 10"	5' 3"	5' 11"	5' 8"	5' 10"	6'	6' 3"	



TABLE 72 (Continued).—TABLE OF QUANTITIES AND DIMENSIONS FOR SINGLE AND DOUBLE BOX CULVERTS.

(Fig. 49.)

Dimensions.	Top & bottom	Height inside (feet) . . . . .	<i>H</i>	5	5	5	6	6	6	6	6	6	6	
		Clear span (feet) . . . . .	<i>S</i>	10	12	14	4	5	6	8	10	12	14	14
	Side walls.	Thickness (in.) . . . . .	<i>a</i>	18	20	22	8	10	12	15	18	20	22	22
		Dia. of rods (in.) . . . . .	<i>b</i>	1	1	1	$\frac{1}{2}$	$\frac{1}{2}$	$\frac{1}{2}$	1	1	1	1	1
		Spac'g of rods (in.) . . . . .	<i>c</i>	5½	5	4½	9½	7½	6½	6½	5½	5	4½	4½
		Length of rods, single culvert . . . . .	<i>d</i>	12' 2"	14' 6"	16' 10"	5' 10"	6' 10"	7' 10"	10' 2"	12' 6"	14' 10"	17' 2"	17' 2"
	Center wall.	Length of rod, double culvert . . . . .	<i>e</i>	23' 4"	27' 10"	32' 4"	10' 10"	12' 10"	14' 10"	19' 4"	23' 10"	28' 4"	32' 10"	32' 10"
		Thickness (in.) . . . . .	<i>f</i>	14	16	18	12	12	12	14	16	18	20	20
		Dia. of rods (in.) . . . . .	<i>g</i>	1	1	1	$\frac{1}{2}$	$\frac{1}{2}$	$\frac{1}{2}$	1	1	1	1	1
		Spac'ng of rods (in.) . . . . .	<i>i</i>	12	14	16	6½	6½	6½	9	10	11	12	12
	Wing walls.	Length of rods . . . . .	<i>j</i>	7' 10"	8' 2"	8' 6"	7' 2"	7' 6"	7' 10"	8' 4"	8' 10"	9' 2"	9' 6"	9' 6"
		Thickness (in.) . . . . .	<i>k</i>	14	16	18	12	12	12	14	16	18	20	20
Dia. of rods (in.) . . . . .		<i>l</i>	$\frac{1}{2}$	$\frac{1}{2}$	$\frac{1}{2}$	$\frac{1}{2}$	$\frac{1}{2}$	$\frac{1}{2}$	$\frac{1}{2}$	$\frac{1}{2}$	$\frac{1}{2}$	$\frac{1}{2}$	$\frac{1}{2}$	
Spac'g of rods (in.) . . . . .		<i>m</i>	24	24	24	24	24	24	24	24	24	24	24	
Wing walls.	Length of rods . . . . .	<i>o</i>	7' 10"	8' 2"	8' 6"	7' 2"	7' 6"	7' 10"	8' 4"	8' 10"	9' 2"	9' 6"	9' 6"	
	Shortest rod . . . . .	<i>p</i>	1' 10"	2' 1"	2' 2"	1'	1' 2"	1' 4"	1' 9"	1' 11"	2' 1"	2' 2"	2' 2"	
	Dif. betw. rods (in.) . . . . .	<i>r</i>	8	9	11	4	4	4	6	6	7	8	8	
Wing walls.	Longest rod . . . . .	<i>t</i>	6' 6"	7' 7"	6' 9"	6' 4"	6' 6"	6' 8"	7' 3"	6' 11"	7' 4"	7' 6"	7' 6"	

Dimensions.	Top & bottom	Height inside (feet) . . . . .	<i>H</i>	8	8	8	8	8	10	10	10	10	10	
		Clear span (feet) . . . . .	<i>S</i>	8	8	10	12	14	8	8	10	12	14	14
	Side walls.	Thickness (in.) . . . . .	<i>a</i>	12	15	18	20	22	15	18	20	22	22	22
		Diam. of rods (in.) . . . . .	<i>b</i>	1	1	1	1	1	1	1	1	1	1	1
		Spac'g of rods (in.) . . . . .	<i>c</i>	8½	6½	5½	5	4½	6½	5½	5	5	4½	4½
		Length of rods, single culvert . . . . .	<i>d</i>	8' 6"	10' 6"	12' 10"	15' 2"	17' 6"	10' 10"	12' 10"	15' 2"	17' 6"	17' 6"	17' 6"
	Center wall.	Length of rods, double culvert . . . . .	<i>e</i>	15' 10"	19' 10"	24' 4"	28' 10"	33' 4"	20' 4"	24' 4"	28' 10"	33' 4"	33' 4"	33' 4"
		Thickness (in.) . . . . .	<i>f</i>	16	16	18	20	22	18	18	20	22	22	22
		Diam. of rods (in.) . . . . .	<i>g</i>	1	1	1	1	1	1	1	1	1	1	1
		Spac'g of rods (in.) . . . . .	<i>i</i>	6	6	6½	7	7½	5½	5½	6½	6½	7½	7½
	Wing walls.	Length of rods . . . . .	<i>j</i>	9' 10"	10' 4"	10' 10"	11' 2"	11' 6"	12' 4"	12' 10"	13' 2"	13' 6"	13' 6"	13' 6"
		Thickness (in.) . . . . .	<i>k</i>	16	16	18	20	22	18	18	20	22	22	22
Diam. of rods (in.) . . . . .		<i>l</i>	$\frac{1}{2}$	$\frac{1}{2}$	$\frac{1}{2}$	$\frac{1}{2}$	$\frac{1}{2}$	$\frac{1}{2}$	$\frac{1}{2}$	$\frac{1}{2}$	$\frac{1}{2}$	$\frac{1}{2}$	$\frac{1}{2}$	
Spac'g of rods (in.) . . . . .		<i>m</i>	24	24	24	24	24	24	24	24	24	24	24	
Wing walls.	Length of rods . . . . .	<i>o</i>	9' 10"	10' 4"	10' 10"	11' 2"	11' 6"	12' 4"	12' 10"	13' 2"	13' 6"	13' 6"	13' 6"	
	Shortest rod . . . . .	<i>p</i>	1' 4"	1' 8"	2'	2'	2' 1"	1' 10"	2'	2' 3"	2' 2"	2' 2"	2' 2"	
	Dif. betw. rods (in.) . . . . .	<i>r</i>	4	4	4	4½	5	3½	3½	4	5	5	5	
Wing walls.	Longest rod . . . . .	<i>t</i>	9'	9' 4"	9' 8"	9' 6"	10'	11' 2"	11' 4"	11' 3"	11' 9"	11' 9"	11' 9"	

154 QUANTITIES SINGLE AND DOUBLE BOX CULVERT.

TABLE 72 (Continued).—TABLE OF QUANTITIES AND DIMENSIONS FOR SINGLE AND DOUBLE BOX CULVERTS.

(Fig. 49.)

Shrinkage rods. All shrinkage rods are  $\frac{1}{2}$  in. diameter and spaced about 2 ft. c. to c. Where laps are necessary make them 3 ft. long.

		3	3	3	3	3	3	3	4	4	
Height inside (feet).....		3	3	3	3	3	3	3	4	4	
Clear span (feet).....		3	4	5	6	8	10	12	14	3	4
Quantities.	Single culvert.										
	Steel per lin. ft., lb.....	34.5	46.3	61.8	77.0	117.0	164.0	211.0	265.0	46.4	59.0
	Conc. per lin. ft., cu. yd.....	0.28	0.41	0.58	0.77	1.18	1.68	2.20	2.75	0.40	0.49
	Add. conc. per lin. ft. for each 1 in. increase in thick'ss, cu. yd....	0.06	0.07	0.08	0.09	0.11	0.13	0.15	0.16	0.07	0.08
	Steel in 2 ends, lb.....	110	224	314	372	580	848	994	1238	304	380
	Conc. in 2 ends, cu. yd.....	2.2	3.0	4.0	5.2	7.5	10.5	13.3	16.2	3.4	4.3
	Add. conc. in 2 ends for each 1 in. increase in thick'ss, cu. yd....	0.31	0.36	0.41	0.46	0.55	0.64	0.73	0.82	0.47	0.52
	Double culvert.										
	Steel per lin. ft., lb.....	52.8	76.9	104.9	135.2	215.1	303.9	395.0	501.0	64.8	90.1
	Conc. per lin. ft., cu. yd.....	0.49	0.73	1.04	1.39	2.18	3.12	4.07	5.14	0.67	0.86
Add. conc. per lin. ft. for each 1 in. increase in thick'ss, cu. yd.	0.09	0.10	0.12	0.14	0.17	0.20	0.24	0.28	0.10	0.11	
Steel in 2 ends, lb.....	255	348	560	625	992	1392	1798	2273	410	555	
Conc. in 2 ends, cu. yd.....	4.4	5.0	6.7	8.6	2.19	18.4	24.3	28.7	4.8	6.7	
Add. conc. in 2 ends for each 1 in. increase in thickness, cu. yd..	0.41	0.49	0.57	0.65	0.80	0.95	1.10	1.24	0.60	0.69	

		4	4	4	4	4	5	5	5	5	
Height inside (feet).....		4	4	4	4	4	5	5	5	5	
Clear span (feet).....		5	6	8	10	12	14	4	5	6	8
Quantities.	Single culvert.										
	Steel per lin. ft., lb.....	75.0	90.0	130.9	175.0	220.0	274.0	76.0	93.0	108.0	154.0
	Conc. per lin. ft., cu. yd.....	0.66	0.88	1.30	1.80	2.34	2.90	0.65	0.78	0.98	1.37
	Add. conc. per lin. ft. for each 1 in. increase in thick'ss, cu. yd.	0.09	0.10	0.12	0.14	0.15	0.17	0.09	0.10	0.11	0.12
	Steel in 2 ends, lb.....	487	592	864	1104	1376	1680	600	750	857	1224
	Conc. in 2 ends, cu. yd.....	5.6	7.1	10.3	13.8	17.6	21.8	6.4	7.5	9.4	12.8
	Add. conc. in 2 ends for each 1 in. increase in thickness, cu. yd....	0.58	0.65	0.74	0.89	1.00	1.12	0.72	0.78	0.86	0.99
	Double culvert.										
	Steel per lin. ft., lb.....	119.0	148.5	228.5	316.3	404.0	510.0	108.0	139.0	169.0	255.0
	Conc. per lin. ft., cu. yd.....	1.18	1.55	2.35	3.32	4.32	5.42	1.09	1.34	1.72	2.46
Add. conc. per lin. ft. for each 1 in. increase in thick'ss, cu. yd.	0.13	0.15	0.18	0.22	0.25	0.29	0.13	0.14	0.16	0.19	
Steel in 2 ends, lb.....	738	906	1394	1928	2438	3069	822	1038	1297	1967	
Conc. in 2 ends, cu. yd.....	9.2	11.3	17.7	24.1	29.9	37.6	9.2	11.7	15.0	21.1	
Add. conc. in 2 ends for each 1 in. increase in thick'ss, cu. yd....	0.80	0.90	1.07	1.30	1.49	1.69	0.94	1.05	1.18	1.41	

QUANTITIES SINGLE AND DOUBLE BOX CULVERTS. 155

TABLE 72 (Concluded).—TABLE OF QUANTITIES AND DIMENSIONS FOR SINGLE AND DOUBLE BOX CULVERTS.

(Fig. 49.)

		5	5	5	6	6	6	6	6	6	
Height inside (feet).....		10	12	14	4	5	6	8	10	12	
Clear span (feet).....		10	12	14	4	5	6	8	10	12	
Quantities.	Single culvert.										
	Steel per lin. ft., lb.....	193.0	234.0	287.0	92.0	109.0	126.0	170.0	213.0	255.0	309.0
	Conc. per lin. ft., cu. yd.....	1.90	2.44	3.03	0.81	0.95	1.11	1.57	2.13	2.69	3.32
	Add. conc. per lin. ft. for each 1 in. increase in thick'ss, cu. yd.	0.14	0.16	0.18	0.10	0.11	0.11	0.13	0.15	0.17	0.19
	Steel in 2 ends, lb.....	1540	1809	2183	860	1038	1190	1610	1954	2376	2784
	Conc. in 2 ends, cu. yd.....	17.4	22.0	27.0	9.1	10.4	12.4	17.0	22.6	28.2	34.2
	Add. conc. in 2 ends for each 1 in. increase in thick'ss, cu. yd....	1.14	1.28	1.43	0.95	1.02	1.10	1.28	1.45	1.62	1.80
	Double culvert.										
	Steel per lin. ft., lb.....	336.0	422.0	524.0	124.0	158.0	190.0	273.0	358.0	444.0	549.0
	Conc. per lin. ft., cu. yd.....	3.46	4.46	5.57	1.36	1.63	1.92	2.78	3.82	4.86	6.03
Add. conc. per lin. ft. for each 1 in. increase in thick'ss, cu. yd.	0.22	0.26	0.29	0.14	0.15	0.17	0.20	0.24	0.27	0.32	
Steel in 2 ends, lb.....	2536	3091	3946	1176	1476	1764	2513	3075	4076	4997	
Conc. in 2 ends, cu. yd.....	28.8	36.8	45.9	12.8	15.5	18.8	26.4	36.4	46.0	56.5	
Add. conc. in 2 ends for each 1 in. increase in thickness, cu. yd..	1.66	1.90	2.14	1.22	1.35	1.48	1.79	2.08	2.37	2.67	

		8	8	8	8	8	10	10	10	10	
Height inside (feet).....		6	8	10	12	14	8	10	12	14	
Clear span (feet).....		6	8	10	12	14	8	10	12	14	
Quantities.	Single culvert.										
	Steel per lin. ft., lb.....	177.0	225.0	268.0	310.0	363.0	263.0	311.0	339.0	381.0	
	Conc. per lin. ft., cu. yd.....	1.56	1.91	2.50	3.10	3.73	2.80	2.72	3.34	4.00	
	Add. conc. per lin. ft. for each 1 in. increase in thick'ss, cu. yd.	0.13	0.15	0.17	0.19	0.21	0.17	0.18	0.20	0.22	
	Steel in 2 ends, lb.....	2202	2782	3250	3800	4473	4100	4810	5240	5838	
	Conc. in 2 ends, cu. yd.....	21.4	25.8	33.6	41.5	49.6	38.0	45.0	54.9	65.3	
	Add. conc. in 2 ends for each 1 in. increase in thick'ss, cu. yd....	1.69	1.88	2.12	2.35	2.57	2.59	2.82	3.11	3.38	
	Double culvert.										
	Steel per lin. ft., lb.....	245.0	330.0	418.0	503.0	604.0	373.0	463.0	532.0	625.0	
	Conc. per lin. ft., cu. yd.....	2.64	3.29	4.40	5.50	6.06	3.90	4.73	5.86	7.06	
Add. conc. per lin. ft. for each 1 in. increase in thick'ss, cu. yd.	0.20	0.22	0.25	0.29	0.32	0.24	0.27	0.30	0.34		
Steel in 2 ends, lb.....	2972	3996	4990	6035	7334	5700	6885	7990	9520		
Conc. in 2 ends, cu. yd.....	29.4	37.9	50.9	65.0	78.2	53.5	66.9	83.8	100.3		
Add. conc. in 2 ends for each 1 in. increase in thick'ss, cu. yd....	2.23	2.57	2.97	3.37	3.74	3.47	3.88	4.38	4.84		

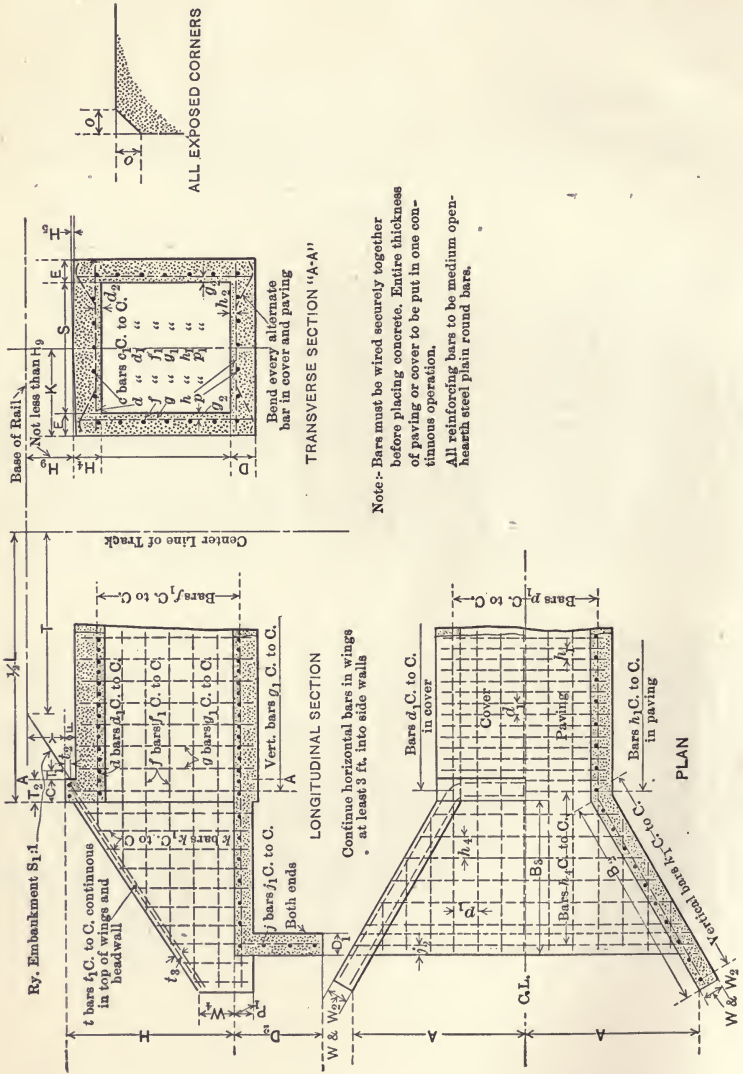

Fig. 50. Chicago G. W. Ry. Standard Reinforced Concrete Culvert.

TABLE 73.— DIMENSIONS OF STANDARD REINFORCED CONCRETE CULVERTS. (Fig. 50.)

Span.	A.	B <sub>2</sub> .	B <sub>3</sub> .	C.	c.	c <sub>1</sub> .	D.	D <sub>1</sub> .	D <sub>2</sub> .	d.	d <sub>1</sub> .	d <sub>2</sub> .	E.
4 × 4	5 2	6 5	4 0	10	5	13	10	10	3 6	4	2	12	
6 × 6	8 0	10 0	7 0	12	7	13	14	12	4 6	6	3	12	
6 × 8	9 4	12 8	8 0	12	7	13	14	12	5 0	6	3	15	
8 × 8	10 7	13 3	9 0	12	9	13	18	12	5 0	5	3	15	
10 × 10	12 10	15 8	10 0	12	11	13	22	12	5 0	4	3	18	

Span.	F.	f.	f <sub>1</sub> .	g.	g <sub>1</sub> .	g <sub>2</sub> .	H.	H <sub>4</sub> .	H <sub>5</sub> .	H <sub>g</sub> .	h.	h <sub>1</sub> .	h <sub>2</sub> .
4 × 4	6	5	13	8	2	5 6	12	12	12	12	4	2	
6 × 6	6	7	13	12	3	7 10	16	16	14	14	6	3	
6 × 8	6	9	13	10	3	9 10	16	16	16	16	6	3	
8 × 8	6	9	13	10	3	10 2	20	1	16	16	5	3	
10 × 10	6	11	13	8	3	12 6	24	2	16	16	4	3	

Span.	h <sub>4</sub> .	j.	j <sub>1</sub> .	j <sub>2</sub> .	K.	k.	k <sub>1</sub> .	O.	P <sub>1</sub> .	p.	p <sub>1</sub> .	S.
4 × 4	6	3	12	5	3 0	12	1	10	5	13	4 0	
6 × 6	12	3	16	6	4 0	12	1	10	7	13	6 0	
6 × 8	12	3	18	6	4 3	12	1	10	7	13	6 0	
8 × 8	12	3	18	6	5 3	12	1	12	9	13	8 0	
10 × 10	12	3	18	6	6 6	12	1	12	11	13	10 0	

Span.	S <sub>1</sub> .	T.	T <sub>1</sub> .	T <sub>2</sub> .	t.	t <sub>1</sub> .	t <sub>2</sub> .	t <sub>3</sub> .	W.	W <sub>2</sub> .	W <sub>4</sub> .	Area of discharge.
4 × 4	1½	7 7½	4½	10	2	6	3	3	10	10	16	16
6 × 6	1½	7 7½	4½	12	2	6	3	3	12	12	20	36
6 × 8	1½	7 7½	4½	12	2	6	3	3	12	12	2 0	48
8 × 8	1½	7 7½	4½	12	2	6	3	3	12	12	2 0	64
10 × 10	1½	7 7½	4½	12	2	6	3	3	12	12	3 0	100

TABLE 74.— REINFORCED CONCRETE CULVERTS, CHIC. G. WEST. RY. (Fig. 50.)

APPROXIMATE QUANTITIES PER LINEAL FOOT INCLUDING PORTALS.

Size of culvert.	4 × 4 ft.	6 × 6 ft.	6 × 8 ft.	8 × 8 ft.	10 × 10 ft.
Barrel per lin. ft., cu. yds.....	0.7	1.2	1.5	2	3
Barrel per lin. ft., metal, lbs.....	68	144	171	214	320
2 portals (2 ends outside AA), cu. yds.....	6.4	16.6	23	28.3	38
2 portals (2 ends outside AA), metal, lbs..	548	1922	2626	2947	4060

# 158 QUANTITIES — REINFORCED CONCRETE CULVERTS.

TABLE 75. — REINFORCED CONCRETE CULVERTS, CHIC. GT. WESTERN RY.

QUANTITIES FOR REINFORCED CONCRETE CULVERTS UNDER FILLS OF 6 FT. TO 50 FT. IN HEIGHT FOR VARIOUS SIZES OF OPENINGS.

(Fig. 50.)

Span.	4 × 4 ft.			6 × 6 ft.			6 × 8 ft.			8 × 8 ft.			10 × 10 ft.			
	Fill in feet.	Length, culvert.	Total in culvert.		Length, culvert.	Total in culvert.		Length, culvert.	Total in culvert.		Length, culvert.	Total in culvert.		Length, culvert.	Total in culvert.	
			Cu. yd.	Metal, lb.		Cu. yd.	Metal, lb.		Cu. yd.	Metal, lb.		Cu. yd.	Metal, lb.		Cu. yd.	Metal, lb.
6	19.2	19.8	1,849	...	...	...	...	...	...	...	...	...	...	...	...	...
8	25.2	24.0	2,257	...	...	...	...	...	...	...	...	...	...	...	...	...
10	31.2	28.2	2,665	24.6	46.0	5,450	...	...	...	...	...	...	...	...	...	...
12	37.2	32.4	3,073	30.6	53.2	6,314	24.6	59.8	6,815	23.6	75.3	7,976	...	...	...	...
14	43.2	36.6	3,481	36.6	60.4	7,178	30.6	68.8	7,841	29.6	87.3	9,260	22.6	105.5	11,260	...
16	49.2	40.8	3,889	42.6	67.6	8,042	36.6	77.8	8,867	35.6	99.3	10,544	28.6	123.5	13,180	...
18	55.2	45.0	4,297	48.6	74.8	8,906	42.6	86.8	9,893	41.6	111.3	11,828	34.6	141.5	15,100	...
20	61.2	49.2	4,705	54.6	82.0	9,770	48.6	95.8	10,919	47.6	123.3	13,112	40.6	159.5	17,020	...
22	67.2	53.4	5,113	60.6	89.2	10,634	54.6	104.8	11,945	53.6	135.3	14,396	46.6	177.5	18,940	...
24	73.2	57.6	5,521	66.6	96.4	11,498	60.6	113.8	12,971	59.6	147.3	15,680	52.6	195.5	20,800	...
26	79.2	61.8	5,929	72.6	103.6	12,362	66.6	122.8	13,997	65.6	159.3	16,964	58.6	213.5	22,780	...
28	85.2	66.0	6,337	78.6	110.8	13,226	72.6	131.8	15,023	71.6	171.3	18,248	64.6	231.5	24,700	...
30	91.2	70.2	6,745	84.6	118.0	14,090	78.6	140.8	16,049	77.6	183.3	19,532	70.6	249.5	26,620	...
32	97.2	74.4	7,153	90.6	125.2	14,954	84.6	149.8	17,075	83.6	195.3	20,816	76.6	267.5	28,540	...
34	103.2	79.6	7,561	96.6	132.4	15,818	90.6	158.8	18,101	89.6	207.3	22,100	82.6	285.5	30,460	...
36	109.2	82.8	7,969	102.6	139.6	16,628	96.6	167.8	19,127	95.6	219.3	23,384	88.6	303.5	32,380	...
38	115.2	87.0	8,377	108.6	146.8	17,546	102.6	176.8	20,153	101.6	231.3	24,668	94.6	321.5	34,300	...
40	121.2	91.2	8,785	114.6	154.0	18,410	108.6	185.8	21,179	107.6	243.3	25,952	100.6	339.5	36,220	...
42	127.2	95.4	9,193	120.6	161.2	19,274	114.6	194.8	22,205	113.6	255.3	27,236	106.6	357.5	38,140	...
44	133.2	99.6	9,601	126.6	168.4	20,138	120.6	203.8	23,231	119.6	267.3	28,520	112.6	375.5	40,060	...
46	139.2	103.8	10,009	132.6	175.6	21,002	126.6	212.8	24,257	125.6	279.3	29,804	118.6	393.5	41,980	...
48	145.2	108.0	10,417	138.6	182.8	21,866	132.6	221.8	25,283	131.6	291.3	31,088	125.6	411.5	43,900	...
50	151.2	112.8	10,825	142.6	190.0	22,730	138.6	230.8	26,309	137.6	303.3	32,372	130.6	429.5	45,820	...

TABLE 76. — DIMENSIONS OF STANDARD PLAIN CONCRETE ARCH CULVERTS.

(Fig. 51.)

Span.	A.	A <sub>1</sub> .	A <sub>2</sub> .	A <sub>3</sub> .	A <sub>4</sub> .	A <sub>5</sub> .	A <sub>6</sub> .	A <sub>7</sub> .	B.	B <sub>1</sub> .	B <sub>2</sub> .	B <sub>3</sub> .	C.	C <sub>1</sub> .	C <sub>2</sub> .	C <sub>3</sub> .	C <sub>4</sub> .
3	1 6	1 6	1 6	1 6	1 6	1 6	4 0	4 0	4 11	4 11	4 11	4 11	''	''	''	''	''
4	2 0	2 0	2 0	2 0	2 0	2 0	4 9	4 9	5 6	5 6	5 6	5 6	''	''	''	''	''
5	2 6	2 6	2 6	2 6	2 6	2 6	5 6	5 6	5 5	5 5	5 5	5 5	''	''	''	''	''
6	8 6	6 3	0 8	6 3	0 3	3 0	6 10	6 4	9 6	8 3	9 6	8 3	2 10	1 6	0 4	1 2	0 2
8	11 3	4 0	11 3	4 0	4 0	4 0	8 3	8 3	12 7	11 4	12 7	11 4	4 2	1 6	0 4	1 2	0 2
10	14 1	5 0	14 1	5 0	5 0	5 0	9 8	10 2	15 9	14 6	15 9	14 6	6 2	1 0	1 6	0 4	1 2
12	16 10	6 0	16 10	6 0	6 0	6 0	11 2	12 0	18 10	17 7	18 10	17 7	12 10	1 6	0 4	1 2	0 2
14	19 9	19 9	19 9	19 9	9 9	7 0	7 0	12 7	12 7	22 1	22 1	22 1	12 10	1 6	0 4	1 2	0 2
16	21 8	21 8	21 8	21 8	8 0	8 0	13 11	13 11	23 9	23 9	23 9	23 9	12 10	1 6	0 4	1 2	0 2
18	23 7	23 7	23 7	23 7	9 0	9 0	15 4	15 4	25 3	25 3	25 3	25 3	12 10	1 6	0 4	1 2	0 2
20	25 6	25 6	25 6	25 6	10 0	10 0	16 8	16 8	26 11	26 11	26 11	26 11	12 10	1 6	0 4	1 2	0 2

Span.	C <sub>5</sub> .	C <sub>6</sub> .	D.	Dd.	D <sub>1</sub> .	Dd <sub>1</sub> .	E.	E <sub>1</sub> .	F.	F <sub>1</sub> .	F <sub>2</sub> .	G.	H.	H <sub>1</sub> .	H <sub>2</sub> .	H <sub>3</sub> .	H <sub>4</sub> .
3	''	''	''	''	''	''	''	''	''	''	''	''	''	''	''	''	''
4	''	0	''	''	2 0	2 0	2 6	2 2	2 0	2 0	2 0	''	7 5	4 0	0 0	0 0	8 0 9
5	''	0	''	''	2 0	2 0	2 9	2 3	2 0	2 0	2 0	''	7 10	4 0	0 0	0 0	10 10
6	0 2	0	Variable.	Variable.	2 0	2 0	3 0	2 6	2 0	2 0	2 0	''	7 9	3 6	0 1	0 1	11
8	0 2	0	''	''	2 0	2 0	3 10	3 6	2 0	2 0	10 <sub>3</sub>	3 0	0 0	2 10	0 4	0 2	1 0
10	0 2	0	''	''	2 0	2 0	4 8	4 2	2 0	2 0	10 <sub>3</sub>	3 0	0 0	3 14	2 6	0 3	1 1
12	0 2	0	''	''	2 0	2 0	5 2	4 7	2 0	2 0	10 <sub>3</sub>	3 0	0 0	4 16	3 7	0 3	1 2
14	0 2	0	''	''	2 0	2 0	5 7	4 11	2 0	2 0	10 <sub>3</sub>	3 0	0 0	4 18	5 8	0 4	3 2
16	0 2	0	''	''	2 0	2 0	5 11	5 3	2 0	2 0	10 <sub>3</sub>	3 0	0 0	5 19	6 8	0 4	3 3
18	0 2	0	''	''	2 0	2 0	6 4	5 8	2 0	2 0	10 <sub>3</sub>	3 0	0 0	5 20	6 8	0 5	3 3
20	0 2	0	''	''	2 0	2 0	6 8	6 0	2 0	2 0	10 <sub>3</sub>	3 0	0 0	6 21	7 8	0 5	10 4

  

Span.	Hg.	Hr.	K.	K <sub>1</sub> .	M.	M <sub>1</sub> .	N.	N <sub>1</sub> .	P.	P <sub>1</sub> .	R.	R <sub>1</sub> .	S <sub>1</sub> .	T.	T <sub>1</sub> .	T <sub>2</sub> .	U.
3	3 0	0 8	4 0	4 0	0 6	3 6	0 0	''	0 9	2 0	2 0	2 9	1 1	1 9	6 0	9 2	0 1
4	3 0	1 0	4 9	4 9	0 6	3 9	0 0	''	0 9	3 0	2 6	3 4	1 1	1 9	6 0	9 2	0 1
5	3 0	1 4	5 6	5 6	0 6	4 0	0 0	''	0 9	4 0	3 0	3 11	1 1	1 9	6 0	9 2	0 1
6	3 0	3 0	5 10 <sub>3</sub>	5 6	0 6	3 10	0 6	6 6	0 5	0 3	0 4	0 11	1 1	1 9	6 0	9 2	0 1
8	3 0	4 0	6 10 <sub>3</sub>	6 6	0 6	4 0	0 6	12 6	0 7	0 4	0 5	1 1	1 1	1 9	6 0	9 2	0 1
10	3 0	5 0	7 10 <sub>3</sub>	7 6	0 6	4 20	0 6	20 6	0 9	0 5	0 6	2 1	1 1	1 9	6 0	9 2	0 1
12	3 0	6 0	8 10 <sub>3</sub>	8 6	0 6	4 30	0 6	30 6	0 11	0 6	0 7	3 1	1 1	1 9	6 0	9 2	0 1
14	3 0	7 0	9 10 <sub>3</sub>	9 10 <sub>3</sub>	0 6	4 30	0 6	42 6	0 13	0 7	0 8	5 1	1 1	1 9	6 0	9 2	0 1
16	3 0	8 0	10 10 <sub>3</sub>	10 10 <sub>3</sub>	0 6	4 40	0 6	56 6	0 15	0 8	0 9	6 1	1 1	1 9	6 0	9 2	0 1
18	3 0	9 0	11 10 <sub>3</sub>	11 10 <sub>3</sub>	0 6	4 40	0 6	72 6	0 17	0 9	0 10	6 1	1 1	1 9	6 0	9 2	0 1
20	3 0	10 0	12 10 <sub>3</sub>	12 10 <sub>3</sub>	0 6	4 40	0 6	90 6	0 19	0 10	0 11	7 1	1 1	1 9	6 0	9 2	0 1

Where wings are at 30° with axis T<sub>1</sub> is 10<sub>3</sub> in.

Span.	W.	Wd.	W <sub>1</sub> .	Wd <sub>1</sub> .	W <sub>2</sub> .	Wd <sub>2</sub> .	W <sub>3</sub> .	Wd <sub>3</sub> .	W <sub>4</sub> .	Wd <sub>4</sub> .	W <sub>5</sub> .	Wd <sub>5</sub> .	W <sub>6</sub> .	Wd <sub>6</sub> .	W <sub>7</sub> .	Wd <sub>7</sub> .	Area of discharge
3	2 0	2 0	2 0	2 0	2 6	2 6	2 6	6 12	10 6	6 1	6 1	6 1	6 1	6 1	''	0	13.3
4	2 0	2 0	2 0	2 0	2 9	2 9	2 9	6 12	10 6	6 6	6 6	6 6	6 6	6 6	''	0	18.7
5	2 0	2 0	2 0	2 0	3 0	3 0	3 0	6 5	10 6	6 6	6 6	6 6	6 6	6 6	''	0	22.1
6	2 6	2 6	2 6	2 6	2 10	2 10	3 4	3 4	3 0	3 0	8 6	8 6	8 6	8 6	1 5	0	39.8
8	2 6	2 6	2 6	2 6	3 0	3 0	3 4	3 4	3 0	3 0	10 7	10 7	10 7	10 7	1 5	0	67.5
10	2 6	2 6	2 6	2 6	3 2	3 2	5 2	5 2	3 0	3 0	12 8	12 8	12 8	12 8	1 5	0	102.3
12	2 10	2 10	2 10	2 10	3 3	3 3	6 0	6 0	3 0	3 0	14 9	14 9	14 9	14 9	1 5	1 5	144.2
14	2 10	2 10	2 10	2 10	3 3	3 3	7 0	7 0	3 0	3 0	16 11	16 11	16 11	16 11	1 5	1 5	193.3
16	2 10	2 10	2 10	2 10	3 4	3 4	7 5	7 5	3 0	3 0	18 0	18 0	18 0	18 0	1 5	1 5	233.5
18	2 10	2 10	2 10	2 10	3 4	3 4	7 10	7 10	3 0	3 0	0 19	0 19	0 19	0 19	1 5	1 5	276.9
20	2 10	2 10	2 10	2 10	3 4	3 4	8 4	8 4	3 0	3 0	0 20	0 20	0 20	0 20	1 5	1 5	323.4

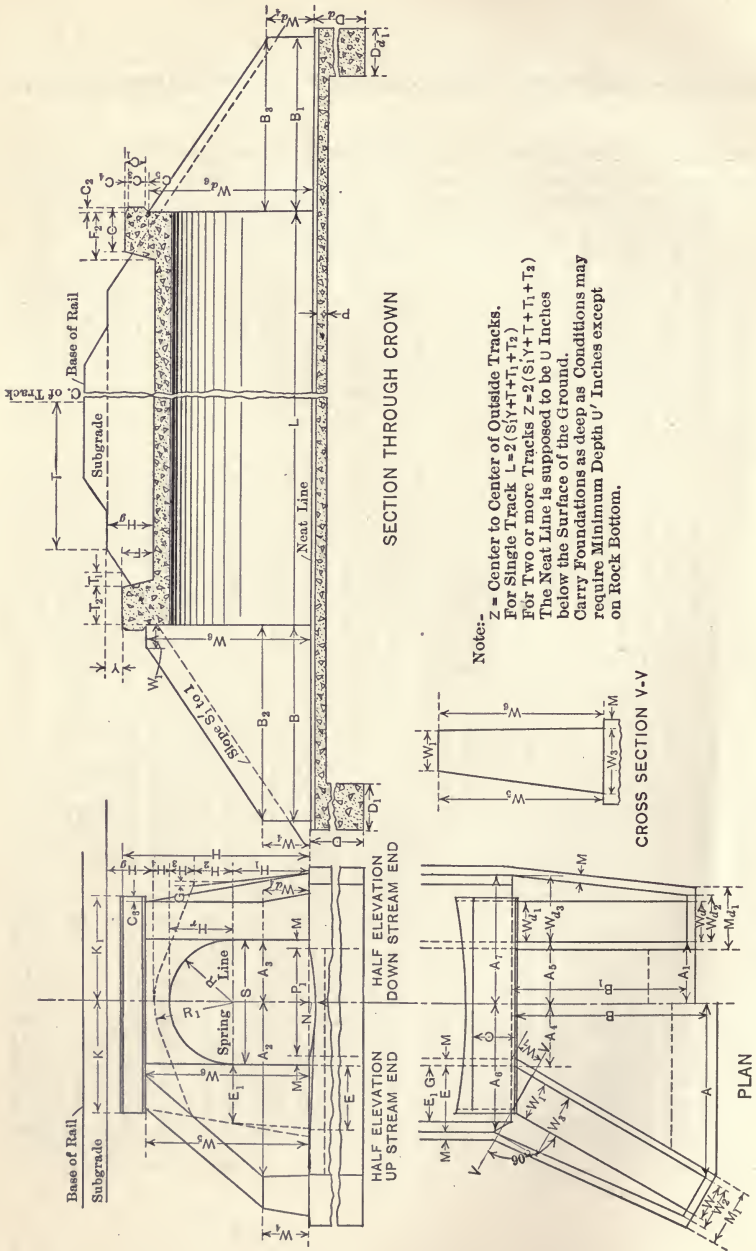

Note:-  
 $Z =$  Center to Center of Outside Tracks.  
 For Single Track  $L = 2(S_1Y + T_1 + T_2)$   
 For Two or more Tracks  $Z = 2(S_1Y + T_1 + T_2)$   
 The Neat Line is supposed to be U Inches below the Surface of the Ground.  
 Carry Foundations as deep as Conditions may require Minimum Depth U' Inches except on Rock Bottom.

Fig. 51. Standard Plain Concrete Arch Culverts, Erie Railroad.



TABLE 77.—PLAIN CONCRETE ARCH CULVERTS, ERIE RAILROAD. (Fig. 51.)

APPROXIMATE QUANTITIES PER LINEAL FOOT INCLUDING PORTALS AND CURTAIN WALLS.

Span.	8 ft.	10 ft.	12 ft.	14 ft.	16 ft.	18 ft.	20 ft.
Barrel per lin. ft.....cu. yd.	2.784	3.703	4.792	5.998	6.703	7.598	8.087
Paving in bbl. per lin. ft.....cu. yd.	0.26	0.333	0.408	0.482	0.556	0.63	0.704
Paving between wing walls.....cu. yd.	12.7	20.38	29.23	54.68	65.11	76.29	88.86
Curtain walls 1 ft. deep.....cu. yd.	2.0	2.63	3.037	5.48	6.00	6.7	7.3
2 portals (w. walls and parapets)....cu. yd.	48.2	74.5	105.2	158.3	186.7	212.0	242.6

TABLE 78.—PLAIN CONCRETE ARCH CULVERTS, ERIE RAILROAD.

QUANTITIES FOR PLAIN CONCRETE ARCH CULVERTS, UNDER FILLS OF 14 FT. TO 16 FT. IN HEIGHT, AND SPANS 8 TO 20 FT.

Fill in feet.	8 ft.		10 ft.		12 ft.		14 ft.		16 ft.		18 ft.		20 ft.		Fill in feet.
	Length, culvert.	Total, cu. yds.	Length, culvert.	Total, cu. yds.	Length, culvert.	Total, cu. yds.	Length, culvert.	Total, cu. yds.	Length, culvert.	Total, cu. yds.	Length, culvert.	Total, cu. yds.	Length, culvert.	Total, cu. yds.	
14	31.5	158.8	...	...	...	...	...	...	...	...	...	...	...	14	
16	37.5	177.1	29.7	217.4	...	...	...	...	...	...	...	...	...	16	
18	43.5	195.3	35.7	241.6	31.0	298.7	...	...	...	...	...	...	...	18	
20	49.5	213.6	41.7	265.8	37.0	329.9	30.5	416.1	...	...	...	...	...	20	
21	52.5	222.8	44.7	277.9	40.0	345.5	33.5	435.6	30.3	477.7	...	...	...	21	
22	55.5	231.8	47.7	290.0	43.0	361.1	36.5	455.0	33.3	499.5	30.3	544.3	...	22	
23	58.5	241.0	50.7	302.1	46.0	376.7	39.5	474.5	36.3	521.3	33.3	569.0	30.0	602.2	23
24	61.5	259.3	53.7	314.3	49.0	392.3	42.5	494.0	39.3	543.1	36.3	593.7	33.0	628.6	24
26	67.5	268.4	59.7	338.5	55.0	423.5	48.5	532.8	45.3	586.6	42.3	643.1	39.0	681.3	26
28	73.5	286.6	65.7	362.7	61.0	454.7	54.5	571.7	51.3	630.2	48.3	692.4	45.0	734.0	28
30	79.5	304.9	71.7	386.9	67.0	485.9	60.5	610.6	57.3	673.8	54.3	741.8	51.0	786.7	30
32	85.5	323.1	77.7	411.1	73.0	517.1	66.5	649.5	63.3	717.3	60.3	791.2	57.0	839.9	32
34	91.5	341.5	83.7	435.3	79.0	558.3	72.5	688.4	69.3	760.9	66.3	840.6	63.0	892.1	34
36	97.5	359.7	89.7	459.6	85.0	579.5	78.5	727.1	75.3	804.5	72.3	899.9	69.0	945.8	36
38	103.5	377.9	95.7	483.8	91.0	610.7	84.5	766.0	81.3	848.0	78.3	939.2	75.0	997.5	38
40	109.5	396.2	101.7	520.1	97.0	641.0	90.5	804.9	87.3	891.5	84.3	998.6	81.0	1050.1	40
42	115.5	414.5	107.7	532.2	103.0	673.1	96.5	843.8	93.3	935.0	90.3	1038.0	87.0	1103.9	42
44	121.5	432.8	113.7	556.4	109.0	704.3	102.5	882.7	99.3	978.6	96.3	1097.4	93.0	1155.6	44
46	127.5	451.1	119.7	580.6	115.0	735.5	108.5	921.6	105.3	1022.2	102.3	1146.7	99.0	1208.2	46
48	133.5	469.3	125.7	604.9	121.0	766.7	114.5	960.5	111.3	1065.7	108.3	1186.1	105.0	1260.9	48
50	139.5	487.6	131.7	629.1	127.0	797.9	120.5	999.4	117.3	1119.3	114.3	1245.5	111.0	1313.6	50
52	145.5	505.8	137.7	653.3	133.0	829.1	126.5	1038.3	123.3	1152.8	120.3	1284.8	117.0	1466.3	52
54	151.5	524.1	143.7	677.5	139.0	860.3	132.5	1077.2	129.3	1196.4	126.3	1334.2	123.0	1419.0	54
56	157.5	542.4	149.7	701.7	145.0	891.5	138.5	1115.9	135.3	1240.0	132.3	1383.5	129.0	1471.7	56
58	163.5	560.6	155.7	726.0	151.0	922.7	144.5	1154.8	141.3	1283.5	138.3	1432.9	135.0	1524.3	58
60	169.5	579.9	161.7	750.2	157.0	953.9	150.5	1193.7	147.3	1327.1	144.3	1482.3	141.0	1577.1	60

**Concrete Arch Culverts.** (Fig. 52.) — Mixture: One cement, 3 sand and 5 broken stone. Excavating, laying, and refilling extra. See Table 79.

*Settlement.* — In places where settlement is likely to occur build in 8 or 10-foot lengths, separated with a heavy layer of tarred felt. Joints to be vertical and the width of base increased.

No filling to be done before concrete has thoroughly set, the minimum time allowed being two weeks.

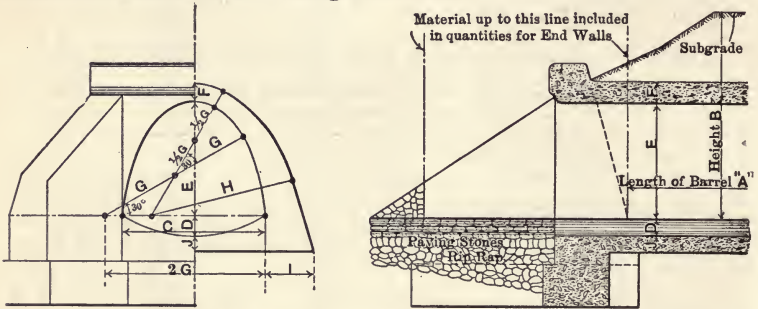

Fig. 52. Concrete Arch Culvert.

**Concrete Arch Culverts.**

TABLE 79. — APPROXIMATE COST AND QUANTITIES.

Dimensions.							Span.	Ht.	L'gth of barrel	Concrete (cu. yds.)			Paving stones.		Rip-rap.		Approximate total cost of culvert.	
J.	I.	H.	G.	F.	E.	D.				C.	B.	A.	Per lin. ft.	2 ends.	In culvert complete.	Cost at \$10.		Sq. yds.
6	1 6	4 2 1/2	2 3 3/8	8	3 2 1/8	6	4	15	50	0.5	18	43	430	9	\$ 13.50	4	12	\$ 456
								20	64	0.5	18	50	500	9	13.50	4	12	526
								30	94	0.5	18	65	650	9	13.50	4	12	676
								40	124	0.5	18	80	800	9	13.50	4	12	826
8	1 9 1/2	5 2 1/2	2 10	9	4 0 1/2	8	5	15	46	0.8	27	64	640	14	21.00	6	18	680
							20	61	0.8	27	76	760	14	21.00	6	18	800	
							30	91	0.8	27	100	1000	14	21.00	6	18	1040	
							40	121	0.8	27	124	1240	14	21.00	6	18	1280	
8	2 0	6 2 1/2	3 4 1/2	10	4 10 1/2	9 1/2	6	15	43	1.0	40	83	830	20	30.00	8	24	884
							20	58	1.0	40	98	980	20	30.00	8	24	1034	
							30	88	1.0	40	128	1280	20	30.00	8	24	1334	
							40	118	1.0	40	158	1580	20	30.00	8	24	1634	
8	2 2	7 1 1/2	3 11 1/2	11	5 7 1/2	11 1/2	7	15	40	1.25	54	104	1040	26	39.00	10	30	1110
							20	55	1.25	54	123	1230	26	39.00	10	30	1300	
							30	85	1.25	54	161	1610	26	39.00	10	30	1680	
							40	115	1.25	54	199	1990	26	39.00	10	30	2060	
							50	145	1.25	54	237	2370	26	39.00	10	30	2440	

## CHAPTER VII.

## ELEVATED STRUCTURES.

**Open Viaducts.** — Where extensive track elevation has taken place in some of the larger cities, it has been found necessary to carry the tracks over and alongside the street on elevated viaducts arranged so as to leave the street underneath as free as possible for vehicle and street traffic.

A structure of this kind, designed in connection with the grade crossing removal on the Phila. & Reading R. R. in Philadelphia for four tracks to be carried on a steel viaduct from Brown Street to Jefferson Street, is shown on page 156.

The viaduct consists of eight lines of longitudinal girders, spaced generally 50 feet in length, has a solid steel waterproof floor and is supported on three column bents, two columns on the curb line and one in the center of the street, resting on concrete and steel, pier foundations.

A structure of this kind is very costly on account of the long spans employed and the extra wide clearance room that has usually to be provided. The other structures illustrated are for conditions very much modified, and the following unit prices adopted for estimating purposes may be considered very fair average prices for work of this character.

Excavation, per cu. yd.....	\$1.00	Drainage, per lin. ft.....	\$1.00
Back fill " " .....	0.50	Steel (structural), per lb....	0.04½
Concrete, plain " .....	8.00	" (reinforcement), per lb.	0.03
" reinforced, cu. yd.	10.00	Waterproofing (fl. slabs), sq.	
" floor slabs, cu. yd.	12.00	yd.....	1.80
Piles, per lin. ft. (wood)....	0.40	Ballast, per cu. yd. (stone)..	1.25
" " " (concrete)..	1.30	Handrail, per lin. ft.....	1.50
		Supervision (about).....	10%



TROUGH FLOOR CONSTRUCTION ON STEEL VIADUCT

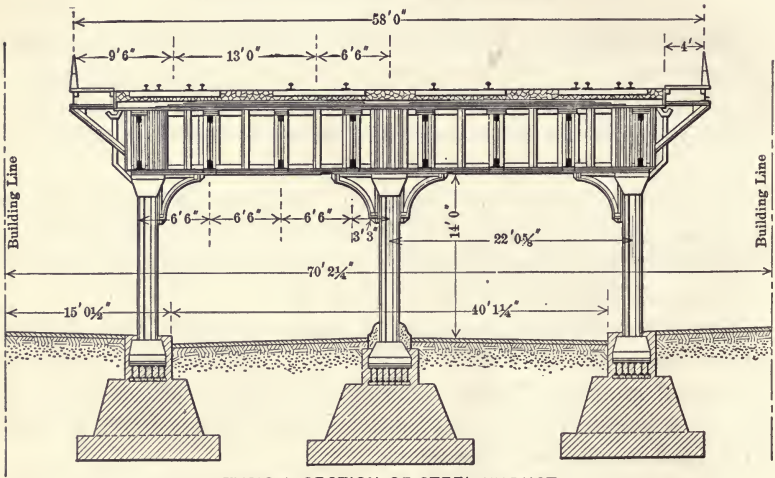

TYPICAL SECTION OF STEEL VIADUCT

TABLE 80. — FOUR TRACK STEEL VIADUCT (Steel and Concrete Floor).

APPROXIMATE ESTIMATE OF COST PER LINEAL FOOT OF VIADUCT.

Excavation.....	5 cu. yds.	\$1.00	\$5.00
Back fill.....	2 cu. yds.	0.50	1.00
Concrete, plain footings.....	1 1/2 cu. yds.	8.00	10.00
Concrete, floor.....	2 cu. yds.	10.00	20.00
Drainage.....	Per lin. ft.	1.00	1.00
Steel, structural.....	7500 lbs.	0.04 1/2	337.50
Steel footing beams.....	350 lbs.	0.03	10.50
Waterproofing floor.....	7 sq. yds.	1.80	12.60
Ballast (stone).....	2 cu. yds.	1.25	2.50
Handrailing.....	2 lin. ft.	1.50	3.00
Supervision.....			40.90
Total cost per lineal foot of viaduct.....			\$444.00

Ties, rails and fastenings, street repairs, etc., that are common to any scheme are not included in the above estimate.

FOUR TRACK VIADUCT CONCRETE SLAB FLOOR

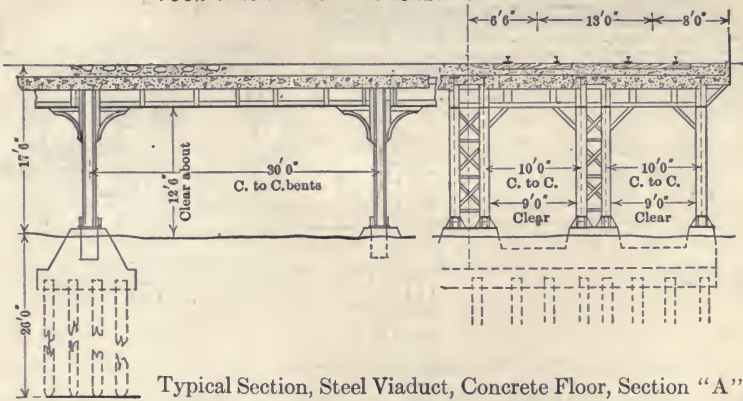

Typical Section, Steel Viaduct, Concrete Floor, Section "A",

FOUR TRACK VIADUCT STEEL OPEN TIE FLOOR

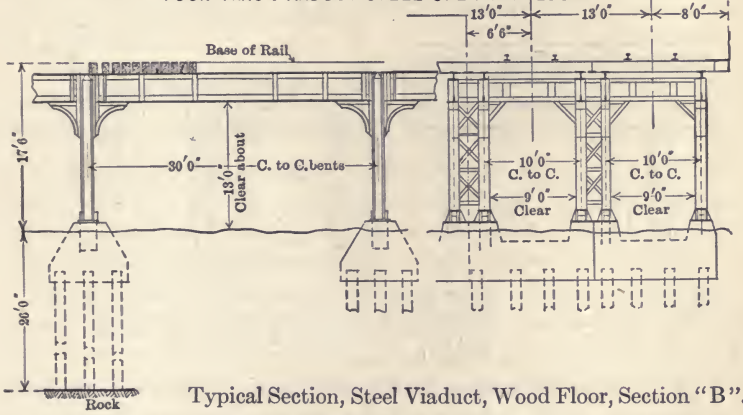

Typical Section, Steel Viaduct, Wood Floor, Section "B".

TABLE 81. — APPROXIMATE ESTIMATE OF COST PER LINEAL FOOT OF VIADUCT.

Items.	Section "A," concrete floor.			Section "B," wood floor.		
Excavation.....	4 cu. yds.	\$1.00	\$4.00	4 cu. yds.	\$1.00	\$4.00
Back fill.....	2 cu. yds.	0.50	1.00	2 cu. yds.	0.50	1.00
Concrete, plain footings.....	2½ cu. yds.	8.00	20.00	2½ cu. yds.	8.00	20.00
Concrete, reinforced (fl. slabs).....	2½ cu. yds.	12.00	30.00	Nil.	Nil.	Nil.
Piles (wood).....	50 l. ft.	0.40	20.00	35 l. ft.	0.40	14.00
Drainage.....	Per lin ft.	.....	1.00	Per lin ft.	.....	1.00
Steel (structural).....	4500 lbs.	0.04½	202.50	3800 lbs.	0.04½	171.00
Steel reinforcement.....	600 lbs.	0.03	18.00	Nil.	Nil.	Nil.
Wood floor.....	2 trk. ties	.....	1.00	4 lin. ft.	7.00	28.00
Waterproofing (fl. slabs).....	7 sq. yds.	1.80	12.60	Nil.	Nil.	Nil.
Ballast (stone).....	2½ cu. yds.	1.25	3.12	Nil.	Nil.	Nil.
Handrailing.....	2 lin. ft.	1.50	3.00	2 lin. ft.	1.50	3.00
Supervision.....	10% (about)	.....	31.78	10% (about)	.....	24.00
Total cost per lin. ft. of viaduct.....	.....	.....	\$348.00	.....	.....	\$266.00

Rails and fastenings common to any scheme are not included in the above estimates.

FOUR TRACK VIADUCT

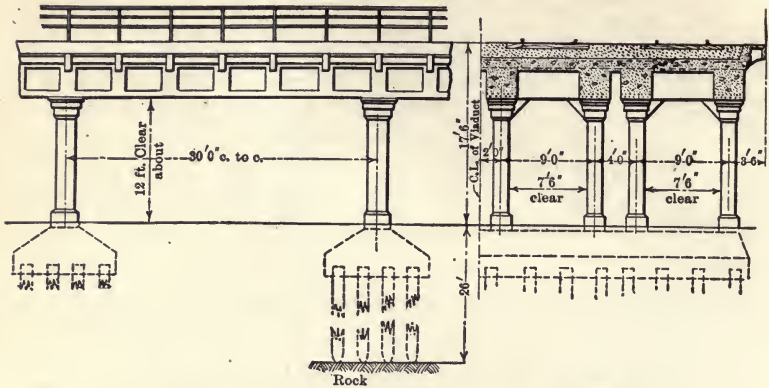

"A" — Typical Section, Reinforced Concrete (30-Ft. Spans).

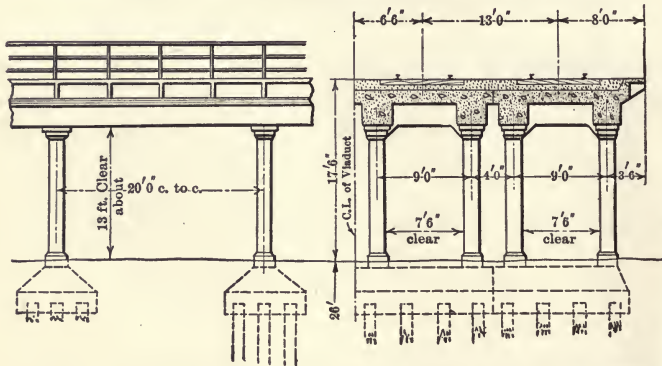

"B" — Typical Section, Reinforced Concrete (20-Ft. Spans).

TABLE 82. — FOUR TRACK REINFORCED CONCRETE VIADUCT.  
APPROXIMATE ESTIMATE OF COST PER LINEAL FOOT OF VIADUCT.

Items.	Section "A," 30-ft. spans.			Section "B," 20-ft. spans.		
Excavation.....	4 cu. yds.	\$1.00	\$4.00	4 cu. yds.	\$1.00	\$4.00
Back fill.....	2 cu. yds.	0.50	1.00	2 cu. yds.	0.50	1.00
Concrete, plain.....	2½ cu. yds.	8.00	20.00	2½ cu. yds.	8.00	22.00
Concrete, reinforced.....	5½ cu. yds.	10.00	55.00	5 cu. yds.	10.00	50.00
Track ties.....	2	0.50	1.00	2	0.50	1.00
Piles (wood).....	50 lin. ft.	0.40	20.00	55 lin. ft.	0.40	22.00
Drainage.....	Per lin. ft.		1.00	Per lin. ft.		1.00
Steel reinforcement.....	1100 lbs.	0.03	33.00	1000 lbs.	0.03	30.00
Waterproofing (fl. slabs).....	7 sq. yds.	1.80	12.60	7 sq. yds.	1.80	12.60
Ballast (stone).....	2½ cu. yds.	1.25	3.12	2½ cu. yds.	1.25	3.12
Handrailing.....	2 lin. ft.	1.50	3.00	2 lin. ft.	1.50	3.00
Supervision.....	10% (about)		15.28	10% (about)		14.28
Total cost per lineal foot of viaduct.....			\$169.00			\$164.00

## VIADUCTS WITH RETAINING WALLS AND FILL, CARRYING TRACKS.

In track elevation work through cities it is often necessary to provide viaducts of some kind to carry the elevated tracks between streets; a very common type consists of a fill supported by retaining walls. In general the railway traffic has to be carried during construction and some means of taking care of it has to be made before the work is started, and usually an elevated temporary trestle carrying one or two tracks is provided for the purpose. In the grade crossing removal on the Phila. & Reading R. R. in Philadelphia between Green Street and Broad Street, a structure of this kind was built with four tracks supported on a solid fill and masonry retaining walls. The traffic was carried during construction on a two track temporary trestle as shown on page 168.

At street crossings pile trestles are usually built to carry the traffic, whilst the excavation is being made for the subways. When the work is large enough track stringers and ties can be used repeatedly at several crossings, and in the case of fills a credit of 20 to 25 per cent may be obtained for the timber removed provided it is in serviceable condition after the construction gangs are through with it.

**Cost of Filled Viaducts with Retaining Walls.** — The cost of this class of work will vary with conditions, for example at Houston the fill or embankment was taken at \$1.00 per cubic yard in place under track, but in the extension work at Chicago the price of 50 cents was generally used on account of the proximity of sand available from along the south shore of Lake Michigan. At other favorable locations it may be as low as 25 cents per cubic yard.

The following figures, therefore, which are fair average prices for work of this character have been used for estimating the various designs.

Excavation, per cu. yd. ....	\$1.00	Drainage, lin. ft. ....	\$1.00
Back fill " " ....	0.50	Steel reinforcement, per lb. ...	0.03
Concrete, plain, " ....	8.00	Waterproofing walls, sq. yd. ..	0.25
Concrete, reinforced, cu. yd.	10.00	Fill, per cu. yd. ....	0.40
Piles (wood), lin. ft. ....	0.40	Supervision. .... (about)	10%

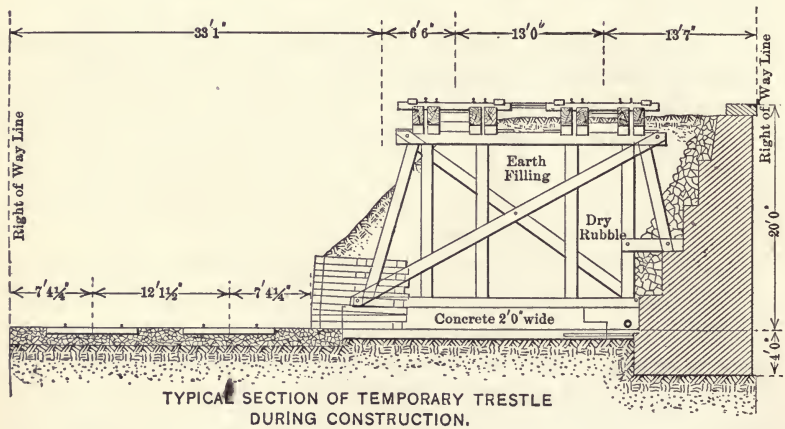
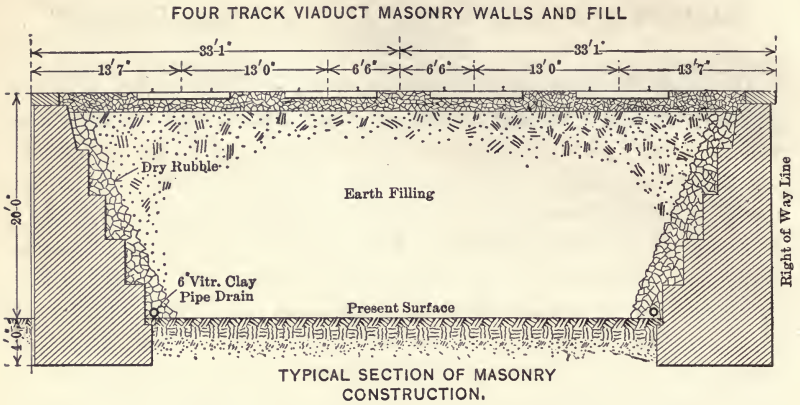

**TABLE 83. — APPROXIMATE COST OF FOUR TRACK VIADUCT WITH FILL AND GRAVITY RETAINING WALLS.**

Excavation.....	3½ cu. yds.	\$1.00	\$3.50
Back fill.....	1½ cu. yds.	0.50	0.75
Masonry, plain.....	16½ cu. yds.	8.00	130.00
Stone backing.....	2½ cu. yds.	1.00	2.50
Drainage.....	Per lineal foot	.....	1.00
Waterproofing walls.....	4 sq. yds.	0.25	1.00
Fill.....	38 cu. yds.	0.40	15.20
Supervision.....	.....	.....	15.05
<b>Total cost per lineal foot of viaduct.....</b>	.....	.....	<b>\$169.00</b>



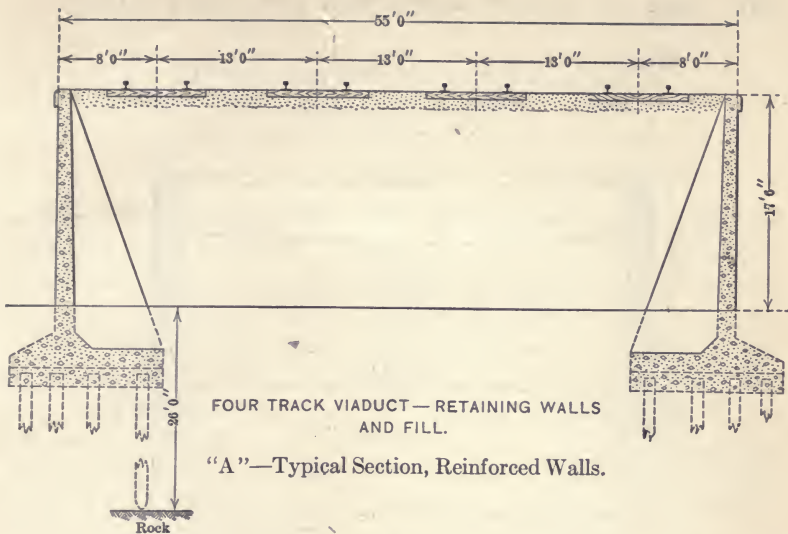

FOUR TRACK VIADUCT—RETAINING WALLS AND FILL.

"A"—Typical Section, Reinforced Walls.

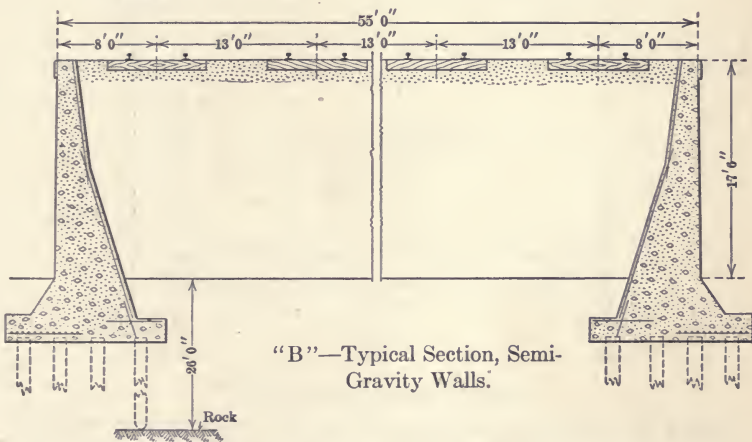

"B"—Typical Section, Semi-Gravity Walls.

TABLE 84. — APPROXIMATE ESTIMATE OF COST PER LINEAL FOOT.

Items.	Section A (22 ft. 6 in. high), reinforced wall.		Section B (22 ft. 6 in. high), semi-gravity wall.			
Excavation.....	6 cu. yds.	\$1.00	\$6.00	6 cu. yds.	\$1.00	\$6.00
Back fill.....	3 cu. yds.	0.50	1.50	3 cu. yds.	0.50	1.50
Piles (wood).....	60 lin. ft.	0.40	24.00	60 lin. ft.	0.40	24.00
Drainage.....	Per lin. ft.	1.00	1.00	Per lin. ft.	1.00	1.00
Concrete (plain).....	1.5 cu. yds.	8.00	12.00	7.6 cu. yds.	8.00	60.80
Concrete (reinforced).....	5 cu. yds.	10.00	50.00	Nil.	Nil.	Nil.
Steel reinforcement.....	350 lbs.	0.03	10.50	500 lbs.	0.03	15.00
Waterproofing walls.....	6 sq. yds.	0.25	1.50	6 sq. yds.	0.25	1.50
Fill.....	40 cu. yds.	0.40	16.00	38 cu. yds.	0.40	15.20
Supervision.....	10% (about)	....	12.50	10% (about)	....	12.00
Total cost per lineal foot of viaduct.....			\$135.00			\$137.00

Ties, ballast, rail and fastenings, or hand rail, common to all schemes are not included. (169)

# 170. COST OF VIADUCT — FILL AND RETAINING WALLS.

CELLULAR RETAINING WALL, MILWAUKEE TRACK ELEVATION.  
TWO TRACK VIADUCT, RETAINING WALLS AND FILL.

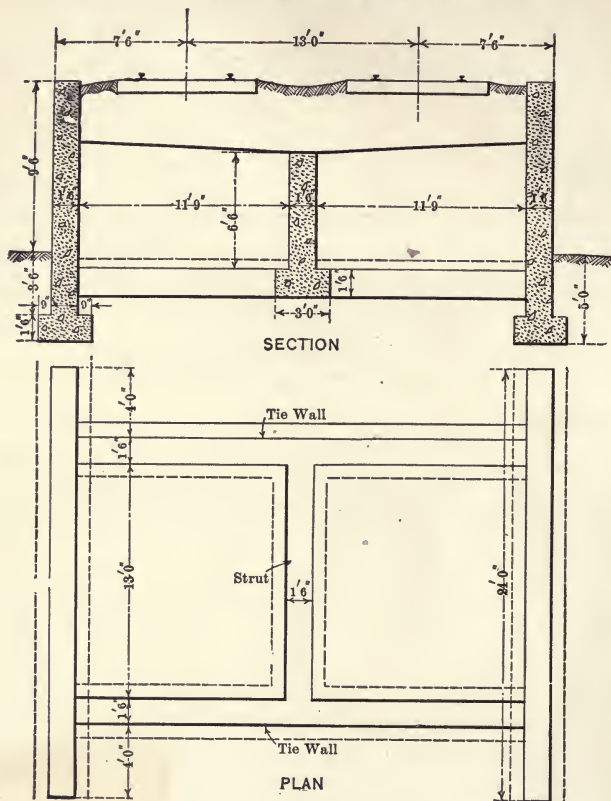

Typical Cellular Construction.

TABLE 85. — APPROXIMATE ESTIMATE OF COST, TWO TRACK VIADUCT WITH RETAINING WALLS AND FILL.

Items.	Quantities.		Section (14 ft. 6 in. high), two tracks.
Excavation.....	4 cu. yds.	\$1.00	\$ 4.00
Back fill.....	2 cu. yds.	0.50	1.00
Drainage.....	Per lin. foot	.....	1.00
Concrete, plain.....	4½ cu. yds.	8.00	36.00
Waterproofing.....	3 sq. yds.	0.25	0.75
Fill.....	9 cu. yds.	0.40	3.60
Supervision.....	10% (about)	.....	4.65
Total cost per lineal foot of viaduct.....	.....	.....	\$51.00

Ties, ballast, rail and fastenings common to any scheme not included in above estimate.

## CHAPTER VIII.

## TIES.

**Wood Ties (Untreated).** — The ties supporting the rails for ordinary track work are usually of wood, although steel ties have been used to some extent and experimental ties of concrete and steel and other combinations are being tried out.

The ordinary wood track tie in general use varies from 6" to 7" in thickness, 6" to 12" in width and 8' 0" to 9' 0" in length, and are either sawn square or hewed, preferably from ties cut in the winter months when the sap is down. When the timbers used are known to be short lived, they should be treated chemically to prolong their life. The bark should be entirely removed before placing in the track.

The A. R. E. A. recommended dimensions for track ties and the woods that may be used for tie timbers with and without treatment, are given below:

TABLE 86. — TIE DIMENSIONS.

Class.	Thickness by width of face (Inches).		Length.		
	Squared.	Pole (flatted).	Feet.	Feet.	Feet.
A.....	7 × 10	7 × 8	8	8½	9
B.....	7 × 9	7 × 7	8	8½	9
C.....	7 × 8	7 × 6	8	8½	9
D.....	6 × 9	6 × 7	8	8½	9
E.....	6 × 8	6 × 6	8	8½	9

*Woods to be used untreated:* white oak family, longleaf strict heart yellow pine, red cypress, redwood, white cedar, chestnut, catalpa, locust, except honey locust.

*Woods to be treated:* red oak family, beech, birch, elm, maple, gum, all pines, except longleaf strict heart yellow pine, Douglas fir, spruce, hemlock, tamarack, yellow and white cypress.

**Switch Ties.** — Switch ties are usually specially dimensioned and of variable lengths. Square sawed switch ties are usually 7" in thickness and 9" in width. When pole or flatted ties are used, they should be not less than 7" thick and 7" in width of face.

TABLE 87. — SIZE OF TIES AND NUMBER USED PER MILE ON VARIOUS RAILWAYS.

(Am. Ry. Eng. Assoc.)

Railroad.	Size of tie.		No. per mile.	Railroad.	Size of tie.		No. per mile.
	In.	Ft.			Ft.	In.	
Southern.....	7 × 7 × 8½	& 9	2880	C. R. I. & P.....	6 × 8 × 8		3200
Pennsylvania.....	7 × 7 × 8½	& 9	2880	St. L. & S. F.....	6 × 8 × 8		3200
L. & N.....	7 × 7 × 8½	& 9	2880	Grand Trunk.....	6 × 8 × 8		3200
B. & O.....	7 × 7 × 8½	& 9	2880	M. K. & T.....	6 × 8 × 8		3200
N. & W.....	7 × 7 × 8½	& 9	2880	Col. & Son.....	6 × 8 × 8		3200
P. & R.....	7 × 7 × 8½	& 9	2880	Maine Central.....	6 × 8 × 8		3200
Penn. (S. W. Sys.).....	7 × 7 × 8½	& 9	2880	C. & E. I.....	6 × 8 × 8		3200
Lehigh Valley.....	7 × 7 × 8½	& 9	2880	C. I. & L.....	6 × 8 × 8		3200
N. C. & St. L.....	7 × 7 × 8½	& 9	2880	El P. & S. W.....	6 × 8 × 8		3200
D. & H. Co.....	7 × 7 × 8½	& 9	2880	St. L. B. & M.....	6 × 8 × 8		3200
A. B. & A.....	7 × 7 × 8½	& 9	2880	F. W. & D. C.....	6 × 8 × 8		3080
Cent. of N. J.....	7 × 7 × 8½	& 9	2880	C. & N. W.....	6 × 8 × 8		3000
B. R. & P.....	7 × 7 × 8½	& 9	2880	C. M. & P. S.....	6 × 8 × 8		3000
C. C. & O.....	7 × 7 × 8½	& 9	2880	C. M. & St. P.....	6 × 8 × 8		3000
A. C. L.....	7 × 7 × 8½	& 9	2816	C. I. & S.....	6 × 8 × 8		3000
Penn. (N. W. Sys.).....	7 × 7 × 8½	& 9	2816	St. L. & S. W.....	6 × 8 × 8		2992
D. L. & W.....	7 × 7 × 8½	& 9	2816	M. & St. L.....	6 × 8 × 8		2992
Fla. E. Coast.....	7 × 7 × 8½	& 9	2816	S. A. & A. P.....	6 × 8 × 8		2992
C. C. C. & St. L.....	7 × 7 × 8½	& 9	3300	Rutland.....	6 × 8 × 8		2992
Hocking Valley.....	7 × 7 × 8½	& 9	3050	Mo. & N. Ark.....	6 × 8 × 8		2992
L. S. & M. S.....	7 × 7 × 8½	& 9	3040	S. Fe., P. & P.....	6 × 8 × 8		2900
Erie.....	7 × 7 × 8½	& 9	2720	L. E. & W.....	6 × 8 × 8		2880
Long Island.....	7 × 7 × 8½	& 9	2720	G. R. & I.....	6 × 8 × 8		2880
S. Pacific.....	7 × 9 × 8		2880	W. & L. E.....	6 × 8 × 8		2880
U. Pacific.....	7 × 9 × 8		2880	N. W. Pac.....	6 × 8 × 8		2880
S. A. L.....	7 × 9 × 8		2880	Mo. Pac.....	6 × 8 × 8		2816
N. Y. N. H. & H.....	7 × 9 × 8		2880	B. & M.....	6 × 8 × 8		2816
C. of Ga.....	7 × 9 × 8		2880	K. C. M. & O.....	6 × 8 × 8		2816
G. H. & S. A.....	7 × 9 × 8		2880	Tam. Cent.....	6 × 8 × 8		2816
Georgia.....	7 × 9 × 8		2880	C. G. W.....	6 × 8 × 8		2880
M. & O.....	7 × 9 × 8		3164	C. H. & D.....	6 × 8 × 8		3168
Northern & Southern.....	7 × 9 × 8		2816	M. C.....	6 × 8 × 8		3564
N. Y. C. & H. R.....	7 × 9 × 8		3200	Ban. & Aros.....	6 × 6 × 8		2880
Great Northern.....	7 × 8 × 8		2880	N. Y. O. & W.....	6 × 9 × 8		3120
S. P. L. A. & S. L.....	7 × 8 × 8		2880	M. J. & K. C.....	7 × 9 × 9		3168
Nor. Pacific.....	7 × 8 × 8		2900	C. St. P. M. & O.....	7 × 7 × 8		2816
D. & R. G.....	7 × 8 × 8		3200	D. S. S. & A.....	7 × 7 × 8		2730
C. B. & Q.....	6 × 8 × 8		3200				

The kind of timbers in use and their average life and cost are estimated as follows: —

TABLE 88. — KIND OF TIES. ESTIMATED LIFE AND COST.

Timbers usually not treated.	Estimated average.		Timbers usually treated.	Estimated average.	
	Life, years.	Cost, cents.		Life, years.	Cost, cents.
Oak (white family).....	9	75	Oak (red family)....	5	60
Pine (long leaf).....	8	60	Pine (western).....	5	55
Cypress (exc. w. cypress)	10	55	Fir (Douglas).....	6	55
Redwood.....	10	70	Beech.....	4	50
Cedar.....	11	75	Gum.....	4	60
Chestnut.....	7	60	Tamarack.....	5	50
Locust (exc. honey loc.)	12	70	Maple.....	4	60
			Birch.....	4	60
			Spruce.....	6	55
			Hemlock.....	5	50

It is stated the railroads in the United States spend annually about \$55,000,000 for renewing ties; this figure does not include labor in distributing, or placing the ties in the track and disposing of the old ones, and forms about fifteen per cent of the total cost of maintenance and three per cent of all operating expenses.

Carloads of ties are usually handled in regular trains to nearest point where needed, so that a work train distributing ties will not be overloaded and can pick up and switch out empties when clearing trains.

. NUMBER OF TIES PER 33 FT. RAIL LENGTH AND PER MILE.

Number of ties per rail length...	13	14	15	16	17	18	19	20	21	22
Average spacing in inches...	30.5	28.3	26.4	24.8	23.3	22	20.9	19.8	18.9	18
Number of ties per mile....	2080	2240	2400	2560	2720	2880	3040	3200	3360	3520

Pennsylvania R. R. specify 18 ties to each 33 ft. of main track.

16 " for sidings.

14 " for yards.

Lehigh Valley " 20 " to each 33 ft. rail.

Average cost of renewing ties in gravel ballast 10 to 15 cts.

" " " " stone " 20 to 25 " .

## A. T. &amp; S. FE (UNTREATED TIES) COST PER MILE OF TRACK.

Material.	Cut spikes and No. tie plates.			Screw spikes and tie plates.		
Ties.....	\$0.62	3,000	\$1860	\$0.62	3,000	\$1860
Inserting ties.....	0.12	3,000	360	0.15	3,000	450
Spikes.....	1.55	12,000	100	3.35	12,000	403
Tie plates.....	.....	.....	Nil.	1.48	6,000	885
Boring ties for screw spikes.....	.....	.....	Nil.	.....	.....	30
Cost per mile of track.....	.....	.....	\$2320	.....	.....	\$3628

It will be noted that the cost per mile with cut spikes and no tie plates is about one third less than screw spikes and tie plates.

## B. &amp; O. RY. (TREATED AND UNTREATED TIES).

Items.	Treated ties, each.	Untreated ties, each.
Purchase price.....	\$0.55	\$0.72
Inspection.....	0.015	0.015
Treatment.....	0.23	.....
Freight.....	0.112	0.065
Unload and pile.....	0.02	0.02
Cost per tie.....	0.93	0.82
Installing in track.....	0.28	0.28

The difference between the cost of the treated and untreated tie on the B. & O. Ry. is only 11 cents. It will be noted that the tie for treatment is of a cheaper quality than the untreated tie.

## C. P. R. (UNTREATED TIES).

Material.	Cut spikes not tie plates.			Cut spikes and tie plates.
Ties.....	\$0.65	3,000	\$1950	\$1950
Inserting ties.....	0.12	.....	360	360
Spikes.....	.....	12,000	216	216
Tie plates.....	.....	.....	Nil.	108
Total per mile of track.....	.....	.....	\$2526	\$2634

Tables showing the estimated life of ties under various conditions of traffic and the comparative annual cost of different classes and grades of ties with different length of life on the B. & O.

The selection provides from one to three choices as to classes and grades of ties in each case, based on a determination of the most economical tie for each condition of track as determined by two factors, namely, the cost in track complete and the assumed life in years.

THE COSTS OF VARIOUS GRADES OF TIES.

Items of cost.	Class A — 8½' grade.			Class A — 8' grade.			Class B — 8½' grade.		Class B — 8' grade.		Class C — 8½' grade.		Classes D and E — 8½' grade.	
	1	2	3	1	2	3	1	2	1	2	1	2	1	2
	\$	\$	\$	\$	\$	\$	\$	\$	\$	\$	\$	\$	\$	\$
Purchase price .....	0.800	0.680	0.250	0.700	0.580	0.250	0.500	0.350	0.400	0.250	0.610	0.510	0.570	0.470
Inspection .....	0.010	0.010	0.010	0.010	0.010	0.010	0.010	0.010	0.010	0.010	0.010	0.010	0.010	0.010
Treatment .....											0.220	0.200	0.220	0.200
Freight:														
80 miles for non-treatment .....														
380 miles for treated .....	0.018	0.018	0.018	0.018	0.018	0.018	0.018	0.018	0.018	0.018	0.090	0.070	0.090	0.070
Work train service .....	0.010	0.010	0.010	0.010	0.010	0.010	0.010	0.010	0.010	0.010	0.010	0.010	0.010	0.010
(a)	0.838	0.718	0.288	0.738	0.618	0.288	0.538	0.388	0.438	0.288	0.940	0.800	0.900	0.760
Handling and installing....	0.190	0.160	0.160	0.190	0.160	0.160	0.160	0.160	0.160	0.160	0.190	0.160	0.190	0.160
Two tie plates .....	0.240	0.120	0.120	0.240	0.120	0.120	0.120	0.120	0.120	0.120	0.240	0.120	0.240	0.120
Interest on (a):														
6 months on untreated,														
12 months on treated .....	0.025	0.022	0.009	0.022	0.019	0.009	0.016	0.012	0.013	0.009	0.056	0.048	0.054	0.046
Supervision .....	0.066	0.066	0.066	0.066	0.066	0.066	0.066	0.066	0.066	0.066	0.066	0.066	0.066	0.066
(b)	1.359	1.086	0.643	1.256	0.983	0.643	0.900	0.746	0.797	0.643	0.492	1.194	1.450	1.152
Credit salvage, one-third value tie plate .....	0.080	0.040	0.040	0.080	0.040	0.040	0.040	0.040	0.040	0.040	0.080	0.040	0.080	0.040
Annual cost per tie with annual life of:	1.279	1.046	0.603	1.176	0.943	0.603	0.860	0.706	0.757	0.603	1.412	1.154	1.370	1.112
6 per cent interest added														
4 years .....	0.400	0.320	0.180	0.360	0.290	0.190	0.270	0.220	0.230	0.190	0.440	0.360	0.420	0.350
6 years .....	0.290	0.240	0.140	0.270	0.210	0.140	0.190	0.160	0.170	0.140	0.320	0.260	0.310	0.250
8 years .....	0.240	0.190	0.110	0.220	0.170	0.110	0.160	0.130	0.140	0.110	0.260	0.210	0.250	0.210
10 years .....							0.140	0.110	0.120	0.100	0.230	0.180	0.220	0.180
12 years .....							0.120	0.100	0.100	0.090	0.200	0.160	0.200	0.160
14 years .....							0.110	0.090	0.100	0.080	0.190	0.150	0.180	0.150
16 years .....											0.170	0.140	0.170	0.140

All of the items which go to make up the total cost of the tie before and after it is delivered are included in the above table, including interest on ties held in stock either treated or untreated, including annual cost per tie with annual life for varying periods.

For selection, the ties are divided into five classes. Class A includes white oak, burr oak, chestnut or rock oak, cherry, mulberry, black walnut and locust. Class B covers chestnut only. Class C covers red oak, black oak, scarlet oak, Spanish oak, pin oak, shingle and laurel oak, honey locust, beech and hard or sugar maple. Class D includes silver, soft or white maple, red, soft or swamp maple, red or river birch, sweet or black birch, white elm, rock elm and red elm. Class E includes only short-leaf pine, loblolly pine and sap longleaf pine. Each class is subdivided into two or three grades determined by the dimensions of the tie.

LIFE OF TIES UNDER DIFFERENT CONDITIONS.

Weight of power and traffic.	Untreated.												Treated.													
	Class A — 8½'.				Class A — 8'.				Class B — 8½'.		Class B — 8'.		Class C.		Classes D & E.											
	Tie plated.		Not tie plated.		Tie plated.		Not tie plated.		Tie plated.	Not tie plated.	Tie plated.	Not tie plated.	Tie plated.	Not tie plated.	Tie plated.	Not tie plated.										
	1	1	2	3	1	1	2	2	3	3	1	1	2	2	1	1	2	2	1	2	1	2				
	7" X 8"				6" X 7"				6" X 6"		6" X 8"		6" X 7"		6" X 6"		7" X 8"		6" X 7"		7" X 9"		7" X 8"			
<i>Main line:</i>																										
Heavy power, dense traffic.....	8	5	.....	.....	.....	.....	.....	.....	.....	.....	.....	.....	.....	.....	.....	.....	.....	.....	11	.....	9	.....	.....	.....	.....	.....
Moderate weight power and traffic.....	9	6	.....	.....	.....	.....	.....	.....	.....	.....	.....	.....	.....	.....	14	.....	12	.....	.....	.....	.....	.....	.....	.....	.....	.....
Light power and traffic.....	9	7	.....	.....	8	6	.....	.....	.....	.....	.....	.....	.....	.....	15	.....	13	.....	.....	.....	.....	.....	.....	.....	.....	.....
<i>Branch line:</i>																										
Heavy power and traffic.....	9	6	8	5	.....	8	5	7	4	.....	.....	.....	.....	.....	.....	.....	.....	.....	14	12	11	10	.....	.....	.....	.....
Moderate weight, power and traffic.....	9	7	8	6	.....	9	6	7	5	.....	.....	.....	.....	.....	.....	.....	.....	.....	.....	.....	.....	.....	.....	.....	.....	.....
Light power and traffic.....	9	8	9	8	8	7	.....	9	8	9	8	8	7	.....	.....	.....	.....	.....	15	13	12	11	.....	.....	.....	.....
<i>Lead and passing:</i>																										
Heavy power and traffic.....	9	7	8	6	.....	8	6	7	5	.....	8	5	.....	.....	7	4	.....	.....	.....	.....	.....	.....	.....	.....	.....	.....
Moderate weight, power and traffic.....	.....	9	7	.....	9	7	8	6	.....	9	7	.....	.....	8	5	.....	.....	.....	.....	.....	.....	.....	.....	.....	.....	
Light power and traffic.....	.....	9	8	8	7	.....	9	8	9	8	7	6	11	7	.....	10	6	.....	.....	.....	.....	.....	.....	.....	.....	
<i>Yard and industrial:</i>																										
Heavy power and traffic.....	.....	9	7	8	6	.....	8	6	7	5	10	7	9	6	.....	9	6	8	5	.....	.....	.....	.....	.....	.....	.....
Moderate weight, power and traffic.....	.....	9	8	8	7	.....	9	8	8	7	11	8	10	7	10	.....	10	7	9	6	.....	.....	.....	.....	.....	
Light power and traffic.....	.....	9	9	9	9	.....	9	9	8	8	12	10	12	10	12	.....	10	11	8	.....	.....	.....	.....	.....		
<i>Repair, temporary and storage:</i>																										
.....	.....	9	9	9	9	.....	9	9	8	8	.....	.....	.....	.....	.....	.....	.....	.....	.....	.....	.....	.....	.....	.....	.....	.....



**C. P. R. Diagrams for Cost of Ties.** — Diagrams for the determination of the economic value of ties have been prepared by J. G. Sullivan, Chief Engineer, C. P. R. (Western Lines), as described in *Eng. News*, Vol. 74, No. 7. There are three diagrams, and one of these is given herewith, based on a formula given by the Tie Committee of the American Railway Engineering Association. The formula is as follows:

$$I + A = \frac{CR(1+R)^N}{(1+R)^N - 1} = \frac{C(1+R)^N}{R(1+R)^N - R}$$

or

$$I + A = \frac{\text{Amount of } C \text{ after } N \text{ years}}{\text{Amount of } \$1 \text{ annuity for } N \text{ years}}$$

$C$  = Final cost of tie in place;

$R$  = Rate of interest;

$I$  = Interest =  $CR$ ;

$N$  = Life of ties in years;

$A$  = Annual contribution to sinking fund, which at compound interest will provide for renewal at end of life of tie.

Example:  $C = \$1.40$ ,  $N = 20$  years,  $R = 5$  per cent.

From table  $(1 + R)^N = 2.6533$ ,  $\log = 0.4237860$

From table  $\frac{(1 + R)^N - 1}{R} = 33.0660$ ,  $\log = 1.5193817$

2.9044043

$C = \$1.40$ ,  $\log = 0.1461280$

$\log = \overline{1.0505323}$

$A + I = \$0.11234$ .

The three diagrams show the value of  $I$  plus  $A$ , from which the annual cost per tie can be taken for ties costing from 40 cents to \$1.50 and varying in life from 2 to 25 years. Mr. Sullivan states that they could be made much easier if they only showed the value of  $A$  — that is, the amount required to be subscribed annually to form a sinking fund which would purchase a tie. To this would be added direct the interest on the first cost of the tie. This would have a slight advantage over the present form in a case where the cost of the present tie will differ from the estimated cost of the new tie.

The same result, however, can be obtained by taking from the diagram the annual cost, using the estimated value of the new tie, and deducting from this the interest per annum at the given rate on this difference. For example, if it is estimated that it will cost 80 cents to renew a tie which cost in place 75 cents and will last 8 years, money figured at 5 per cent, take from the diagram the annual cost of an 80 cent tie lasting 8 years, which is 12.4 cents, and deduct from this the interest at 5 per cent on the difference in the actual cost and the estimated cost of the renewal, 5 cents, which is 0.25 cents. This makes the annual cost 12.15 cents instead of 12.4 cents.

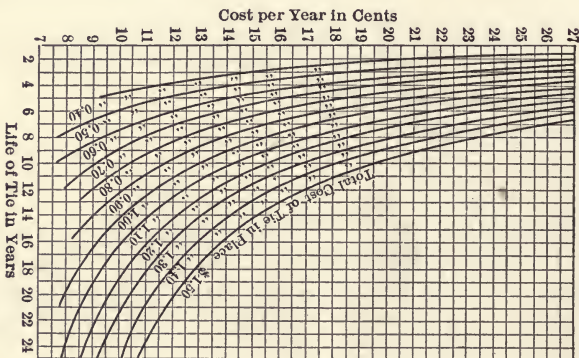

TABLE OF ANNUAL COST OF TIES LASTING VARIOUS LENGTHS OF TIME COSTING IN PLACE VARIOUS SUMS, MONEY FIGURED AT 5 PER CENT.

Life in years.	Cost in place.											
	\$0.40	\$0.50	\$0.60	\$0.70	\$0.80	\$0.90	\$1.00	\$1.10	\$1.20	\$1.30	\$1.40	\$1.50
1	0.420	0.525	0.630	.....	.....	.....	.....	.....	.....	.....	.....	.....
2	0.215	0.269	0.322	0.376	0.430	0.484	0.538	.....	.....	.....	.....	.....
3	0.147	0.184	0.221	0.257	0.294	0.331	0.368	0.405	0.442	.....	.....	.....
4	0.113	0.141	0.169	0.198	0.226	0.254	0.282	0.310	0.338	0.367	0.396	0.423
5	0.092	0.115	0.139	0.162	0.185	0.208	0.230	0.254	0.278	0.301	0.324	0.345
6	.....	0.098	0.118	0.138	0.157	0.177	0.196	0.216	0.236	0.256	0.276	0.294
7	.....	0.086	0.104	0.121	0.138	0.155	0.172	0.190	0.208	0.225	0.242	0.258
8	.....	0.078	0.093	0.109	0.124	0.139	0.156	0.171	0.186	0.202	0.218	0.234
9	.....	.....	0.084	0.098	0.112	0.126	0.141	0.155	0.168	0.182	0.196	0.210
10	.....	.....	0.077	0.091	0.104	0.117	0.129	0.142	0.154	0.168	0.182	0.195
11	.....	.....	.....	0.084	0.096	0.108	0.120	0.132	0.144	0.156	0.168	0.180
12	.....	.....	.....	0.079	0.090	0.102	0.113	0.124	0.136	0.147	0.158	0.169
13	.....	.....	.....	.....	0.085	0.096	0.107	0.117	0.128	0.138	0.149	0.160
14	.....	.....	.....	.....	.....	0.090	0.101	0.111	0.121	0.131	0.141	0.151
15	.....	.....	.....	.....	.....	0.087	0.096	0.106	0.116	0.125	0.135	0.144
16	.....	.....	.....	.....	.....	0.083	0.092	0.101	0.111	0.120	0.129	0.138
17	.....	.....	.....	.....	.....	.....	0.089	0.098	0.107	0.115	0.124	0.133
18	.....	.....	.....	.....	.....	.....	0.086	0.094	0.103	0.111	0.120	0.129
19	.....	.....	.....	.....	.....	.....	0.083	0.091	0.099	0.108	0.116	0.124
20	.....	.....	.....	.....	.....	.....	0.080	0.088	0.096	0.105	0.112	0.120

## TREATED TIES.

All timber is subject to decay more or less from wood destroying fungi, an organism that obtains its food supply from the timber and causes its destruction. To poison the food supply of this organism and thereby protect the timber and prolong its life a number of different chemical treatments have developed; in the preservation of ties the treatments have in general been confined to the following toxic or antiseptic compounds:

1. Creosote.
2. Zinc chloride.
3. Creosote and zinc chloride.
4. Miscellaneous preservatives.

TABLE 89. — NUMBER OF CROSS TIES TREATED IN 1914 IN THE UNITED STATES.

(Amer. Wood Preservers' Association.)

Kind of wood.	Per cent each kind of total treated.	Kind of preservative.			Miscellaneous preservatives.	Total number.
		Creosote.	Zinc chloride.	Zinc chloride and creosote.		
Oak.....	37.39	6,537,857	8,549,073	1,159,929	148,275	16,395,134
Yellow pine....	24.19	7,102,396	1,866,627	111,998	1,526,243	10,607,264
Douglas fir....	17.63	5,452,516	2,221,163	.....	57,085	7,730,764
Western pine..	5.40	712,631	1,656,721	.....	.....	2,369,764
Beech.....	2.37	572,828	252,415	114,466	.....	1,039,709
Gum.....	2.08	255,672	536,267	32,091	86,833	910,863
Tamarack.....	1.86	183,044	340,462	.....	290,424	813,930
Maple.....	1.22	419,535	132,644	28,728	.....	580,907
Birch.....	0.77	126,735	.....	.....	208,700	335,435
Elm.....	0.10	1,972	41,358	.....	.....	43,330
Other species..	6.89	1,226,257	976,855	509,066	308,121	3,020,299
Total.....	100	22,591,443	16,673,585	1,956,278	2,625,681	43,846,987

Hewed ties treated comprised about 70 per cent or 30,222,183, while 13,624,804 were sawed. The price of domestic creosote in 1914 averaged 8 to 8½ cents per gallon f.o.b. plant. Miscellaneous preservatives include crude oil, paving oil, refined coal tar, and oils reported as carbolineum.

Approximately 135,000,000 ties are purchased annually by railroads and about 33 per cent are being treated.

It is conceded that with the present day rail fastenings, treated ties are destroyed by mechanical wear sooner than by decay and the American practice is therefore to make the treatment only sufficient to well outlast the mechanical life of the average tie which for estimating purposes may be considered to be 14 years.

The wear is principally from rail cutting and spike killing; to protect the tie from rail cutting, tie plates are used; to lessen the spike killing screw spikes have been introduced, and treated tie plugs are used to fill up the gap from a redrawn spike as a partial remedy to reduce the injury, and to guard against too rapid decay the treatment of ties with chemicals before placing in the track is generally being adopted.

The average life of the better class of ties is about 7 to 8 years and the average cost 75 cents.

The average cost of removing an old tie and inserting a new one is about 23 cents.

It has been estimated by the Chicago and North Western that the cost of the average untreated tie, hemlock or tamarack, when laid for use west of the Mississippi, is 75 cents.

On the Baltimore and Ohio the average price has increased from 50 cents in 1904 to 75 cents in 1913 or 40 per cent in ten years. The average cost of ties on the Can. Pac. have increased from 35 cents in 1904 to 43 cents in 1914 or about 20 per cent.

The present day preservatives used for the treatment of ties, for all practical purposes, may be confined to zinc chloride (a salt) and creosote (an oil), used separately or in combination under a variety of different processes.

That creosote is the best wood preservative is an established fact, but its cost is two to three times that of zinc chloride.

In 1903 the number of ties treated in the United States was 9,010,000 of which 8,400,000 were treated with chloride of zinc and 610,000 with creosote.

In 1914 the number of ties treated was 43,846,987 of which 16,673,585 were treated with chloride of zinc, 22,591,443 with creosote and 1,956,278 with zinc chloride and creosote, and the balance 2,625,681 with miscellaneous preservatives.

In 1903 the proportion of ties treated with creosote was less

than 10 per cent but in 1914 it had increased to over 50 per cent whilst the zinc chloride treatment has fallen from 90 per cent in 1903 to less than 30 per cent in 1914. This indicates that in the intervening years between 1903 and 1914 a field of usefulness has been found for each process. What this field is for each is necessarily not well defined but is somewhat as follows:

**Creosote.** — For the treatment of ties that have a fair average life untreated (6 to 7 years or over) and for which a positive long life is desired after treatment, the treatment being modified to suit requirements, and the characteristics of the various timbers to be treated.

**Zinc Chloride.** — For the treatment of ties that have a short natural life (4 years or less), ties that would not pay to put in the track unless treated; its greatest field is in arid and semi-arid locations or where the rainfall is light.

**Creosote and Zinc Chloride.** — A combination treatment introduced as a medium between the more costly creosote and the fairly cheap zinc chloride treatment, and a desire to overcome the defect of leeching that takes place in the zinc chloride treatment.

To obtain results the treatment must be thorough and the impregnation very complete; the ties should be mechanically adzed and bored before impregnation and properly seasoned before and after treatment.

The cost of tie treatments to 1913 from 16 principal railways in the United States (A. R. E. A. Bulletin 164) is reported as follows:

TABLE 90.

Kind of treatment.	Maximum, cents.	Minimum, cents.	Average, cents.
Creosote, company plant.....	0.380	0.250	0.276
Creosote, contract.....	0.324	0.235	0.289
Zinc chloride, company plant.....	0.112	0.100	0.104
Zinc chloride, contract.....	0.155	0.150	0.152
Card process, company plant.....	0.176	0.175	0.175

The above costs are said to include labor, material, fuel, handling of ties at plant and charges for interest, and depreciation in the case of company plants. Since 1913, however, the prices of chemicals have risen considerably and the above figures are exceptionally low.

The cost of treating a hemlock tie on the Can. Pac. is estimated at 21 cents and with creosote 33 cents per tie, and figuring 8 years as the average life for the untreated tie, and 12 years after treatment with zinc chloride, and 14 years with creosote, the results are as follows:

Weight untreated, 150 lbs.; treated, 165 lbs.; cost of tie untreated, 43 cents.

Items for 24 year period.	Untreated tie (8 years).	Treated tie, zinc chloride (12 years).	Treated tie creosote (14 years.)
Cost of tie.....	0.43	0.430	0.430
Cost of transportation.....		0.016	0.016
Placing in track.....	0.15	0.160	0.160
Distributing.....	0.01	0.010	0.010
Treating tie.....		0.210	0.326
Treated tie plugs.....		0.014	0.014
	0.59	0.84	0.956
Interest 5 per cent (compound).....	8 yr. 0.28 0.87	12 yr. 0.66 1.50	14 yr. 0.934 1.89
First renewal.			
Cost of tie (increased value).....	0.47	0.50	0.51
Remainder as above.....	0.16	0.41	0.526
	0.65	0.91	1.036
Interest 5 per cent (compound).....	8 yr. 0.30 0.93	12 yr. 0.72 1.63	1.014
Second renewal.			10 yr. 2.05 × $\frac{1}{2}$ 1.46
Cost of tie (increased value).....	0.51		
Remainder as above.....	0.16		
	0.67		
	8 yr. 0.32 0.99		
Cost of tie in 24 years.....	\$2.79	\$3.13	\$3.35
Cost of tie per annum.....	0.116	0.130	0.14

**Steel Ties.** — A great deal of attention has been given during the past few years to finding a substitute for wood ties, and many designs of steel, concrete, and composite ties are being tried out, and the steel tie has been the most successful so far.

The type that has been used chiefly is known as the Carnegie Steel Tie, illustrated herewith, and for which a number of different weights of sections are given in Table 90a. These are made up in sections varying in weight from 20 to 27.8 lbs. per foot. The rolled steel plates and fastenings are not included in the weights and have to be added when making up the cost figures.

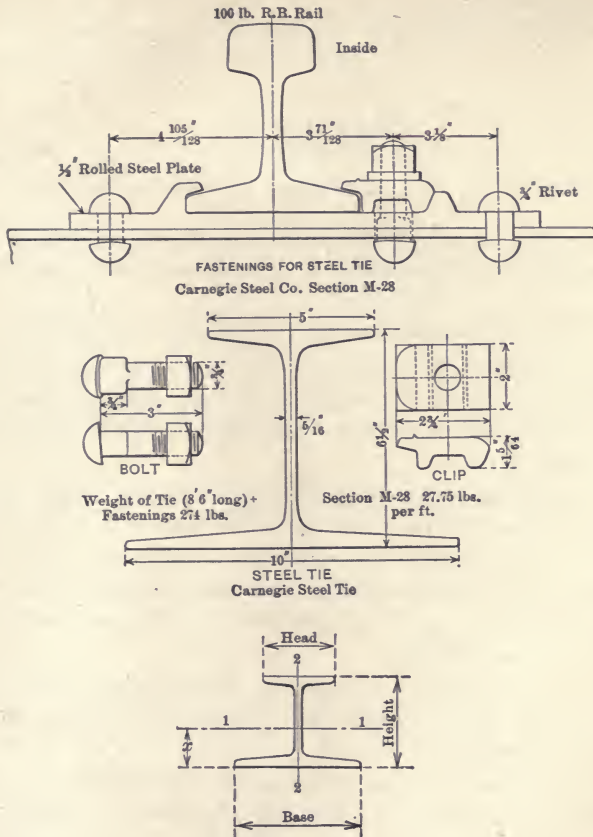

TABLE 90a.

Section index.	Depth of section.	Weight per foot.	Area of section.	Width of flange.		Thick-ness of web.	Axis 1-1.				Axis 2-2.		
				Top.	Bot'm.		<i>l</i> .	<i>r</i> .	<i>S</i> .	<i>x</i> .	<i>l</i> .	<i>r</i> .	<i>S</i> .
				In.	In.		In. <sup>4</sup>	In.	In. <sup>3</sup>	In.	In. <sup>4</sup>	In.	In. <sup>3</sup>
M 21	5.50	20.0	5.71	4.5	8.0	0.250	30.9	2.33	9.7	2.33	14.9	1.62	3.7
M 25	4.25	14.5	4.10	4.0	6.0	0.250	13.0	1.78	5.5	1.88	6.1	1.22	2.0
M 24	3.00	9.5	2.80	3.0	5.0	0.203	4.3	1.24	2.5	1.27	3.1	1.05	1.2
M 28	6.5	27.8	8.18	5.0	10.0	0.375	58.0	.....	14.4	2.48	.....	.....	.....

## CHAPTER IX.

## RAIL.

**Steel.** — The manufacture of rail has been from iron to Bessemer steel and from Bessemer to open-hearth and special alloy steel.

The output of Bessemer steel has steadily declined since 1906 and the production of open-hearth has been increasing at a corresponding rate, while the tonnage of alloy steel remains about stationary and is quite small in comparison with the total tonnage of rails rolled.

In the construction of main line switch points, frogs, diamond crossings, curves, and places of excessive wear, it is quite common practice to use special and hardened steel rails such as cast manganese steel, rolled manganese steel, majari steel, silicon rail, and Bessemer and open-hearth rail treated with ferrotitanium and other alloys.

*Design.* — The A. S. C. E. sections, as presented by the American Society of Civil Engineers in 1893, have generally been adopted as standard.

The A. R. A. sections, series A and B as adopted by the American Railway Association in 1898, have been used to some extent.

The A. R. E. A. sections were submitted by the rail committee of the American Railway Engineering Association in 1915, but have not yet been approved by the Association.

The standard weights in service are mostly 85 up to 105 lb. In 1915, 66 per cent of all rails rolled were of 85 lb. section and over. Quite a number of roads have heavier than 100 lb. sections in service; among these may be mentioned the New York Central, 105 lb.; Lehigh Valley, 110 and 136 lb.; Pennsylvania, 125 lb.; and the Central New Jersey, 135 lb. See Fig. 52a.

Another type of rail section that has developed within the past year or two is the so-called frictionless rail, designed to reduce the frictional resistance and wear between the rail and the wheel



flanges on curves. It has a deep narrow head with sloping sides, the base remaining the same as in the ordinary rail; it is being tried out by a number of railroads.

DESIGN OF RECENT HEAVY RAIL SECTIONS. Fig. 52a.

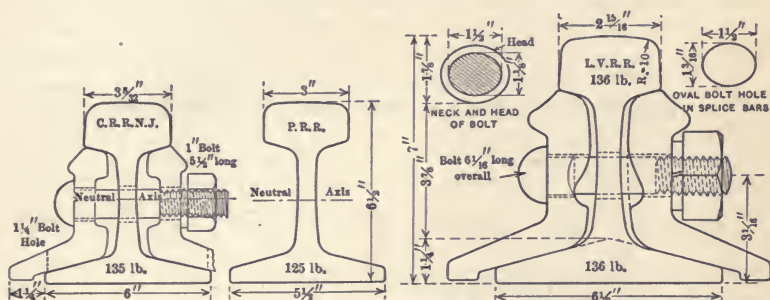

Railway . . . .	Lehigh Valley R. R.	Pennsylvania R. R.	Central R. R. of New Jersey
Weight . . . . .	136 lb.	125 lb.	135 lb.
Height . . . . .	7 in.	6½ in.	6½ in.
Head . . . . .	35.4%, 4.72 sq. in.	38.9%, 4.73 sq. in.	40.28%
Web . . . . .	23.7%, 3.17 sq. in.	20.3%, 2.47 sq. in.	21.90%
Base . . . . .	40.9%, 5.46 sq. in.	40.8%, 4.95 sq. in.	37.82½%
Total . . . . .	100.0%, 13.35 sq. in.	100.0%, 12.15 sq. in.	100.00%
Moment of inertia.	86.57	68.7	72.39

It is recognized that the margin of safety in regard to rails is quite small; for this reason the heavier the rail section, other things being equal, the better will be the service and the more economical it will be in maintenance and operation.

The tonnage rolled of the A. R. E. A. rail series A and B have been fairly successful in service under favorable conditions. It is stated that these sections can be rolled in the mill at a lower temperature than the ordinary A. S. C. E. rail and that therefore a finer grain and better weaving surface is secured.

The following figures give the production of rails rolled in the United States in 1915, from which it will be noted that the open hearth process is about 81 per cent of the total and that the Bessemer process only amounts to about 15 per cent.

The production of re-rolled rails for 1915 by the various manufacturers was 102,083 gross tons.

Electric process and heat-treated rails are at present in experimental use only.

PRODUCTION OF RAILS IN THE UNITED STATES IN 1915.

Production by processes.			Production by weight.			
Kinds.	Gross tons.	Per cent.	Under 50 lb.	50 lb. and less than 85.	85 lb. and less than 100.	100 lb. and over.
Open-hearth.....	1,775,168	80.54	.....	.....	.....	.....
Bessemer.....	326,952	14.83	.....	.....	.....	.....
All other.....	102,083	4.63	.....	.....	.....	.....
Gross tons.....	2,204,203	100.00	254,101	518,291	742,816	688,995

PRODUCTION OF ALLOY-TREATED STEEL RAILS, 1915.

Kinds.	Gross tons.	Per cent.	Under 50 lb.	50 lb. and less than 85.	85 lb. and less than 100.	100 lb. and over.
Titanium.....	21,191	85.00	.....	.....	.....	.....
Other alloys.....	3,779	15.00	.....	.....	.....	.....
Gross tons.....	24,970	100.00	6	1977	6555	16,432

Processes; open-hearth and electric, 24,367; Bessemer, 603; total, 24,970 tons.

The heavier section of rail, over 100 lb. per yard, has only come into service within the past few years and the production in 1915 was just a little less than the amount rolled of 85 to 100 lb., so that it is likely the heavier rail, over 100 lb., will exceed all others in the next year or two.

The prime chemical composition and the physical characteristics of steel for track work, given by W. C. Cushing, are about as follows:

CHEMICAL COMPOSITION.

Kind of steel.	Manganese.	Carbon.	Phosphorus.	Silicon.	Sulphur.
Manganese.....	11-13	1.0-1.20	0.06-0.11	0.25-0.40	0.02-0.06
Bessemer.....	0.80-1.10	0.45-0.55	Not to exceed 0.10	Not to exceed 0.20	.....
Open-hearth.....	0.60-0.90	0.62-0.75	Not to exceed 0.04	Not to exceed 0.20	.....

PHYSICAL CHARACTERISTICS.

Kind of steel.	Lb. sq. in., tensile strength.	Lb. sq. in., elastic limit.	Elonga- tion, per cent in 2 in.	Reduc- tion of area per- centage.	Hardness by	
					Brinell.	Sclero- scope.
Manganese (cast)...	75,000-102,000	40,000-58,000	8-27	15-29	230	40-50
Bessemer.....	89,000-126,000	44,000-62,000	5-25	5-43	172-230	29-35
Open-hearth.....	115,000-156,000	54,000-80,000	9-16	10-30	230-300	32-43

The following figures for rolled and for forged manganese steel are given by W. S. Potter:

Kind of steel.	Lb. sq. in., tensile strength.	Lb. sq. in., elastic limit.	Elongation, per cent in 2 in.
Cast steel.....	82,000	45,000	30
Rolled metal.....	135,000	60,000	35
Forged metal.....	142,000	55,000	38

Cost. — Rails are usually delivered in 33-foot lengths, ends sawed square and bolt holes for splice connections accurately drilled. A small percentage in shorter lengths is generally accepted; the best rails are usually termed No. 1, and those not of the best No. 2. No. 1 rail only is used in main line or fast running track.

Rails are bought and paid for on the actual weight, and are usually quoted in gross tons (2240 pounds) and weight per yard (3 lineal feet). Rails in 45 ft. and 60 ft. lengths are used to some extent.

AVERAGE ESTIMATING PRICES, 1915.

Rail and fastenings.	Approximate cost.	
	Per gross ton.	Per 100 lb.
Rail (new).....	\$33	\$1.47
Angle bars with rail.....	45	2.00
Bolts, track (common).....	79	3.55
Bolts, track (heat treated).....	95	4.25
Spikes ( $5\frac{1}{2} \times \frac{9}{16}$ ).....	54	2.41
Tie plates.....	45	2.02
Nut locks per 1000, \$12.00.....	.....	.....
Rail anchors each 16¢.....	.....	.....

For rolled manganese rail about \$95 per ton. In the case of an addition of titanium, the cost is from 5 to 12 per cent in excess of the plain steel and for nickel rail about 75 per cent, under normal conditions.

Where rail has failed from battering at the ends, it is usual to saw off the defective ends and redrill the holes before relaying for branch line service. The cost of resawing may be estimated at 75 cents per ton, which includes picking up rail, taking it to shops, redrilling, sawing, reloading and salvage from scrap. The average scrap value of old rails for a number of years prior to 1915 was about \$12 per ton and the average price of new rail \$30 per ton, or the difference in value between scrap and new rail was about \$18.

A. M. Wellington writing in 1902 states that the average life of good steel rails weighing 60 to 80 lb. per yard is about 150,000,000 to 200,000,000 tons or from 300,000 to 500,000 trains. From 10 to 15 lb. or  $\frac{3}{8}$  to  $\frac{5}{8}$  of an inch in height of head of rail is available for wear and abrasion takes place at the rate of about 1 lb. per 10,000,000 tons, or  $\frac{1}{8}$ " per 14,000,000 to 15,000,000 tons.

The reasonable cost per train mile of rail wear may be estimated at from 0.3 to 0.5 cents as follows:

Cost of one mile steel rails, 95 tons @ \$30.....	\$2850
Less scrap value of unworn rail (nearly half).....	1350
Leaving as net cost of wearing portion, per mile.....	\$1500

Divided by total life 300,000 to 500,000 trains gives 0.3 to 0.5 cents per train mile, but in view of present difficulty of getting good rails and a tendency to increase the weight of trains, we may assume the even figure of one cent per train mile.

Rail statistics on the Northern Pacific indicated a loss of weight due to wear in four years of about 0.5 per cent per 10,000,000 tons duty. This would indicate a loss of about 1.25 per cent per year per 100,000,000 tons duty.

*Re-rolled Rails.* — Since 1910 a process of re-rolling old rails has been in vogue with very satisfactory results.

Usually the larger section rails that are slightly worn and not sufficiently good for main line are re-rolled and used on branch lines. The rails are heated and practically all of the work is done on the head of the rail, straightening it up, etc.

The work elongates the head considerably, making it, of course, lighter in section than the original. The reduction varies from six to ten pounds, according to the wear and kind of finish it receives.

The re-rolled rail needs to be classified and various classes of rails must be laid together, to obtain the best results.

The cost of re-rolling averages from \$5 to \$7 per ton, the Railway Company paying the freight to and from the mills.

The practice on the C. M. & St. P. R. R. is not to re-roll any rail less than 85 lb., although 65 lb. and 75 lb. have been re-rolled; the rail shipped for re-rolling is usually in pretty fair condition, free from burrs, and not worn more than  $\frac{1}{4}$  in. at any point.

On the Ill. Cent. and Chi. G. West., rails have been re-rolled from 67 lb. to about 60 lb.; the process is said to have toughened the rail and made a very satisfactory rail in use.

The Santa Fé, the B. & O., and Chic. and N. West., have also used re-rolled rails extensively.

For weights and quantities of rail and fastenings, see page 20. For renewing rail, capital and maintenance charges, see page 21. For cost of laying rail, see page 12.

## CHAPTER X.

## OTHER TRACK MATERIAL.

**Rail Joints.** — There is no common standard rail joint; most railroads have developed their own designs and there are in general use a number of different types, the most common of which is the angle bar.

The angle bar was first introduced about 1868; previous to this the fish plate was used; at that time both the fish plate and angle bar fitted flat against the web of the rail, and about 1870 both were improved by making the inside of the bar concave so that only the top and bottom of the bar came in contact with the rail; the recent improvement to this type of bar is a widened base with a slight vertical turndown at the side and a reinforcing of the upper part of the web near the under side of the rail head. Figs. 54 and 55. The patented joints that have been used to any extent are of two kinds; — the base supported type such as the Continuous, the Weber, and the Wolhaupter, page 11, and the deep girder type such as the Duquesne, Hundred per cent, and the Bonzano. A plain bar that has given good service is the C. P. R. standard, Fig. 53.

The Rock Island bars, Fig. 54, are heat treated and quenched in oil and are applied with 1 in. heat-treated track bolts and spring washers, standard tie plates, and  $\frac{5}{8}$  in. by 6 in. track spikes.

The tendency is towards a plain four-holed bar splice 24 in. long with 1 in. bolts for 90 lb. rail and over U. S. standard thread, with a good make of spring nut lock, square head tap. There is also a desire to obtain a joint bar that will dispense with the necessity of respacing ties when relaying rail, with its added expense and resulting disturbance of roadbed that is so detrimental to good riding track. Some of the roads that are relaying rail without respacing ties are the Lehigh Valley, the Illinois Central, the Pittsburg and Lake Erie, and the C. P. R.

Some roads to strengthen the joint are using a base plate under the rail; the Pennsylvania R. R. use a long base plate extending over four ties, which is said to not only strengthen the joint but makes an excellent anticreeper as well.



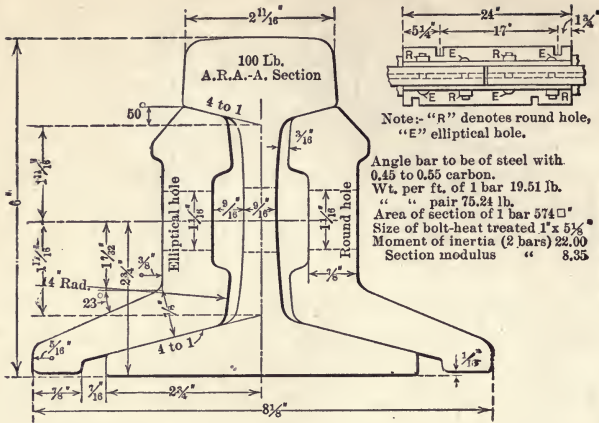

Fig. 54. Rock Island 100-lb. Rail — Angle Bar.

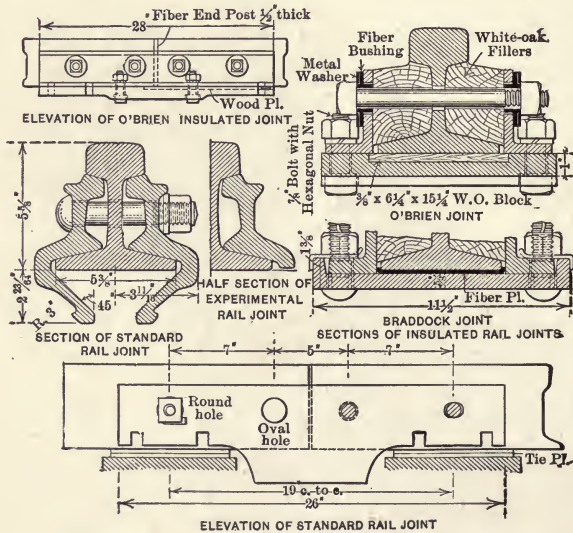

Fig. 55. Phila. & Reading 100-lb. Rail Splice.

Where two different sections of rail come together compromise or step up joints are commonly used, or a tapered rail each end of which has a different section to match the two sizes of rail which it connects.

The insulated joint, Fig. 55, in track was brought about by the



adoption of track circuits, and formerly was accomplished with wooden splice bars, but with the increase of weight and speed of trains, the weakening of the joint with a wooden bar was soon demonstrated and insulating material between the parts of the joint structure took its place.

The 100 per cent type of bar used by the Phila. & R. R. is shown, Fig. 55, for 100-lb. rail; the bars are 26 in. long and slotted for the track spikes. The bolts are 1 in. diameter, with oval necks, and heads shaped to fit ribs of splice bars. Spring-nut blocks are used. The bolts are placed with heads alternately on the inner and outer sides. For insulated rails the Phila. & Reading use the O'Brien and Braddock joints. The rail ends are separated by  $\frac{1}{2}$ -in. fiber end post shaped to the rail section.

**Bolts and Nut Locks.** — The bolts used in coupling up the joint bars to the rail must be of sufficient strength so that a trackman cannot twist, bend or stretch it with a wrench; to provide against this the elastic limit of the material must be high and the result is usually obtained by heat treatment of the bolts at a slight extra cost.

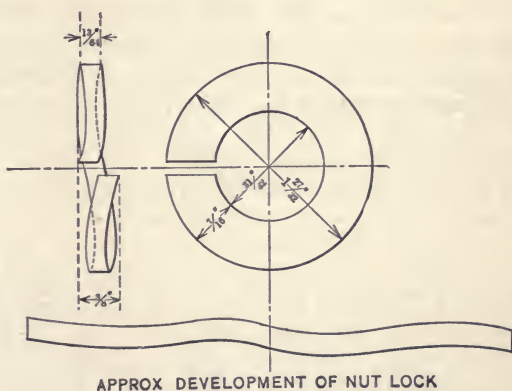

APPROX DEVELOPMENT OF NUT LOCK

The ordinary track bolt with a nut lock or a self-locking grip bolt such as the "Harvey" are most commonly used.

Loose bolts are the cause of most of the deterioration of the rail at the joints and great care is usually taken to keep them tight; to this end also a great number of different types of nut

locks have been introduced, the spring effect of which takes up the looseness resulting from wear until adjustment can be made. With the lock nut the adjustment of course can only be made with the wrench. The bolts are usually placed alternately on the outside and inside of the rail, which in the case of derailment protects the joint bolts from being entirely stripped, and incidentally makes a better balanced joint.

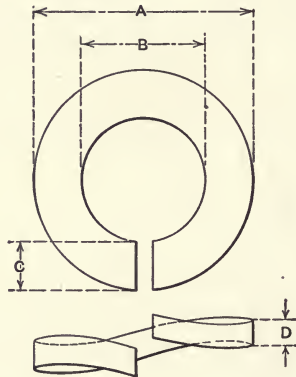

The cost of maintaining the self-locking bolts may be estimated at from \$10 to \$12 per year (bolts tightened twice a year).

The cost of maintaining the nut locks may be estimated at from \$6 to \$8 per year (bolts tightened once a year) per mile of track.

H. P. TRACK SIZES OF NUT LOCKS.

Approximate number of horsepower required per mile of track.	Size, in.	Effective pressures in pounds.	Dimensions.				Number per keg.	Approx. net weight per M., lb.	Wt. of keg, lb.	Number of horsepower required for a min. car load.
			A, diam. outer, in.	B, diam. inside, in.	C, width, in.	D, height, in.				
.....	$\frac{3}{4}$	6,000	$1\frac{3}{4}$	$\frac{5}{8}$	$\frac{3}{8}$	$\frac{7}{16}$	2500	72	10	462,000
33' rail, 4 bolt splices, 1280....	$\frac{7}{8}$	8,000	$1\frac{3}{4}$	$\frac{3}{4}$	$\frac{7}{8}$	$\frac{1}{2}$	2000	109	10	328,000
33' rail, 6 bolt splices, 1920....	1	10,000	$1\frac{3}{4}$	$1\frac{3}{8}$	$\frac{7}{8}$	$\frac{3}{8}$	1500	122	10	263,000
30' rail, 4 bolt splices, 1408....	$1\frac{1}{8}$	12,500	$2\frac{3}{8}$	$1\frac{5}{8}$	$\frac{1}{2}$	$\frac{1}{2}$	1000	160	10	206,000
30' rail, 6 bolt splices, 2112....	$1\frac{1}{4}$	15,000	$2\frac{3}{8}$	$1\frac{3}{8}$	$\frac{1}{2}$	$\frac{1}{2}$	1000	186	10	178,000



**Rail Anchors.** — Rail anchors or rail creepers have come into general use during the past two or three years. It is generally conceded that the anchoring of the rail to the ties supporting the joint by spiking through the slotted holes in the flanges of the angle bars places most of the anchorage on one side of the joint ties, on broken jointed track, and makes an unbalanced joint, and unless rail creepers are used the rail on the opposite side of the joint ties will not maintain a square position across the track.

The creeping of rails of sufficient magnitude to cause track disturbances, except in very rare cases, is the result of forces generated by the rolling load, according to Mr. P. M. LaBach; such as creeping due to the tractive power of the locomotive, creeping due to the friction of locked wheels, creeping due to wave motion in the track and creeping due to the discontinuity of the track structure.

The creeping due to the tractive power of the locomotive tends to move the rail in a direction contrary to that of the locomotive. The creeping due to locked wheels will be found where stops are made and will be in the direction of traffic. The creeping due to wave motion increases directly as the load and the tie spacing and inversely as the stiffness of the rail, and will increase with the speed, the stress in the rail and the traffic. The creeping due to the discontinuity of the track structure from worn angle bars or loose or poorly designed joints causes an increased hammering on the ends of the rails in the same direction as traffic, and increases with the speed, load and flexibility of the rail. The creeping due to wave action and to hammering of the ends is in the same direction.

The creeping of track (rails and ties together) occurs sometimes on swampy roadbed, owing to the wave motion under traffic. The M. St. P. & S. St. M. Ry. use ten and twelve foot long ties with angle bars spiked to two ties at the center of the rail, to keep the rails from creeping on the ties.

In laying rail, anchors are used permanently, according to conditions, to keep the rail from creeping under traffic, by distributing the resulting stresses throughout the rail length rather than concentrating it on the joint ties. For this reason, slot spiking the joints and the spacing of joint ties have been abandoned on many roads. Rail creepers are also used to prevent

rail from crowding the frog or wing rail of frog, on spring rail frogs on one way traffic.

The boltless, self-maintaining wedge, skew, spring or clamps are the most generally used types. Among the many in general

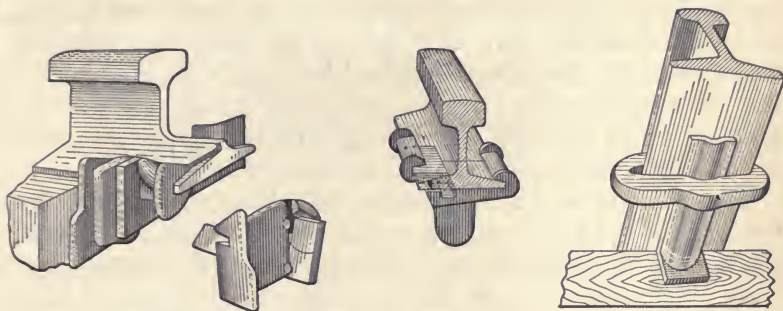

Vaughan.

P. & M.

Dinklage.

Rail Anchors.

use may be mentioned the "L. & S.," a bolt operated anchor, the "Dinklage," a two-piece anchor, the "Ajax," a two-piece wedge anchor, the "Vaughan," a two-piece anchor with a spring, the "Positive," a one-piece anchor, and the "P. & M.," a two-piece anchor of the wedge type, and the "Sullivan" plate anchor.

THE COST OF RAIL ANCHORS IN PLACE.

Four anchors per rail, 1280 per mile @ 16¢ . . . . .	\$204.80
Labor applying @ 0.013 each . . . . .	19.20
Total . . . . .	<u>\$224.00</u>

It is estimated an annual saving of from \$250 to \$400 per mile can be made by the use of anchors which would otherwise be spent on maintenance in driving back rail, squaring up slewed ties, resurfacing, etc. Under favorable conditions with stone ballast and heavy section rail four anchors to a 33 ft. rail is recommended, placed without reference to joints but always opposite each other and against the same tie, one pair preferably in each quarter rail length. The adoption of the uniform spacing of ties without reference to the joints means a large saving in maintenance as it is estimated that the average cost of respacing

joint ties and surfacing track (on account of respacing) approximates \$350.00 per mile on stone ballasted line where rails are laid with staggered joints.

**Spikes.** — Spikes are used to fasten or hold the rail to the ties; two kinds are in service, the ordinary common cut spike and the screw spike. The functions of the spike are to prevent the rail from spreading, overturning or lifting; the outer line of spikes therefore resists the lateral or side thrust, the inner line anchors the rail and prevents it from canting, while both lines simultaneously hold the rail from lifting vertically from the wave action which develops in the rail when under stress.

The spike therefore is measured by its holding power and as the cut spike is not half as strong in this respect as the screw spike the latter is undoubtedly the best fastening for the purpose, but there are certain features in track maintenance and climatic conditions in this country that make it undesirable to adopt it under all circumstances.

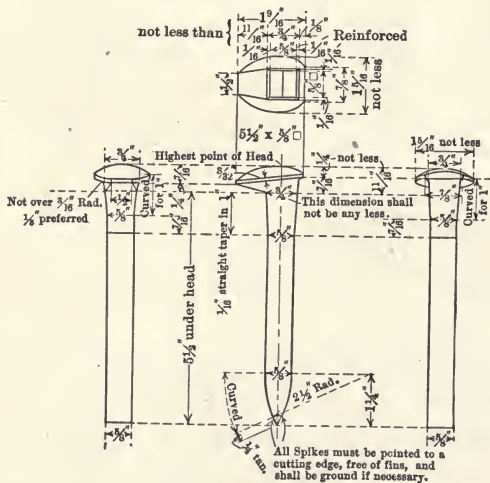

Fig. 56. C. P. R. Cut Track Spikes.

**Cut Spikes.** — The common cut spike is in general use but is largely objected to on account of its limited holding power both vertically and laterally and is the cause of the tie being rapidly destroyed by spike killing, entailing thereby a very heavy main-

tenance cost in tie renewals; so far as the lateral holding power of the spike is concerned the introduction of the tie plate has greatly strengthened it in this respect and for lines of ordinary traffic it is doubtful if it will ever be entirely superseded by the

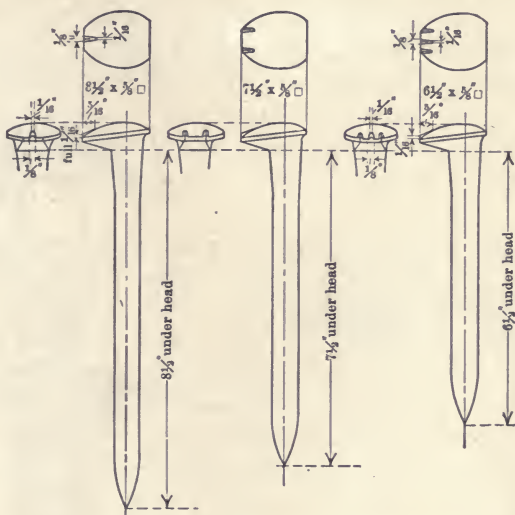

Fig. 57. C. P. R. Shimming Spikes.

screw spike. Figs. 58 and 59 illustrate the A. R. E. A. proposed standard cut and screw spikes and Figs. 56 and 57 the C. P. R. standard cut track spikes and shimming spikes.

The average standard cut track spike is  $\frac{9}{16}$  in. sq.  $\times$   $5\frac{1}{2}$  in. long. Average weight 0.65 lb. each.

TONS AND KEGS OF SPIKES REQUIRED PER MILE SINGLE TRACK (FOR VARYING NUMBER OF TIES).

Ties per mile.	Spikes per mile.	Weight, lb.	Per mile, tons, 2000 lb.	Number of kegs.		Lb. per 100 ft. of track.
				200 lb. each.	224 lb. each.	
2600	10,400	6760	3.38	34	30½	128
2800	11,200	7280	3.64	36½	32½	138
3000	12,000	7800	3.90	39	35	148
3200	12,800	8320	4.16	42	37½	158

Quantities allowed per mile (C. P. R. single track).

Construction (new track).....	34 kegs per mile (224 lb. per keg).
Maintenance (relaying rail).....	4 " " " "

Approximate cost of spiking one mile:

12,000 spikes distributed.....	\$216
Driving cut spikes per mile.....	84
	<hr/>
	\$300

If tie plated, add 6000 tie plates at 16¢.

Total..... \$1260 per mile (single track)

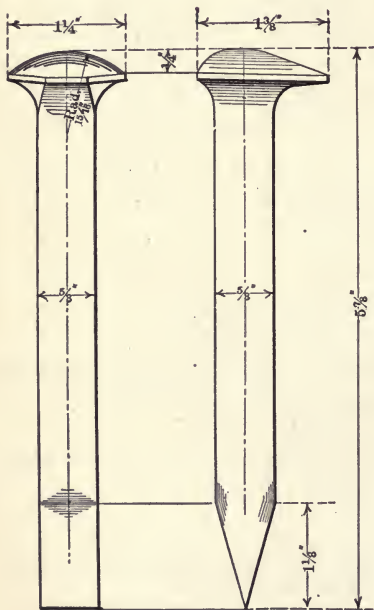

Fig. 58. A. R. E. A. Proposed Std. Track Spike.

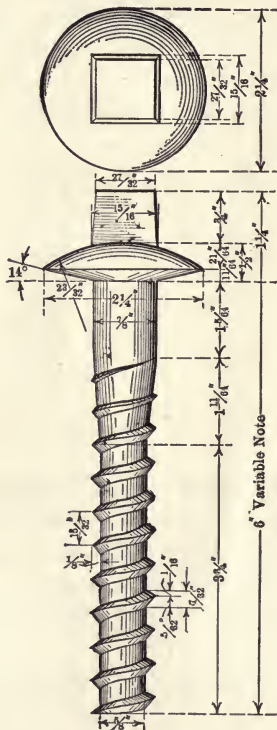

Fig. 59. A. R. E. A. Proposed Standard Screw Spike.

*Screw Spikes.* — The Lackawanna introduced the screw spike both on maintenance and construction about 1910, and have now over 12,000,000 in service and the results obtained are on the whole favorable.



The cost of applying screw spikes for labor only is about \$300 per mile in excess of applying cut spikes. On the other hand, with the use of screw spikes it is considered that the maintenance charges for lining and surfacing and tightening fastenings will be reduced, especially on heavy traffic lines.

On lines of dense traffic the screw spike is being used by many roads to obtain a more rigid track and while the results are not by any means conclusive it is said to increase the mechanical life of ties, as it decreases the wear between the rail tie and tie-plate, reduces spike killing, has a greater grip, is stronger laterally and does not loosen readily, retards creeping and eliminates noisy track.

The objections to their use is increased first cost, greater difficulty in withdrawing the spikes when making repairs or renewals, being most serious in case of a derailment. Amongst the roads that are using them to a large extent may be mentioned the A. T. & Santa Fé, D. Lacka. & Western, C. Rock Isl. & Western, N. Y. N. H. & H., Union and Southern Pacific, the Penn., etc.

The cost of material is about double the cost of cut spikes. In relaying rail or removing broken rail more time is consumed and consequently the cost of such work will be more than with the ordinary cut spike.

*Cost of installing screw spikes:*

Sante Fé.	(Machine boring) 1½¢ per hole or	6¢ per tie
Rock Island.	Placing two tie plates, boring 4	
	holes and driving spikes by hand	14½¢ " "
" "	Average by machine.....	4¢ " "
Penn.	Preparing ties for screw spikes and	
	drilling 8 holes on construction	
	work.....	4¢ " "
"	Driving screw spikes by machine,	
	aver.....	.9¢ " spike
New Haven.	Driving screw spikes by machine,	
	aver.....	.7¢ " "
B. & O.	Driving screw spikes by machine,	
	aver.....	1.1¢ " "
Penn.	Preparing tie exclusive of treat-	
	ment.....	5.3¢ to 15¢ per tie
"	Placing tie in track exclusive of lin-	
	ing and surfacing.....	10.6 to 19.5¢ per tie
A. T. & S. F.	Installing screw spikes and dowels for one mile (single track):	
	12,000 screw spikes @ 2.7¢ each.....	\$324
	6,000 tie plates @ 21¢ each.....	1260
	Boring ties and driving dowels.....	240
	Wood dowels.....	360
	Driving screw spikes.....	150
	Total.....	\$2334



TABLE 92. — HOLDING POWER OF CUT AND SCREW SPIKES.

Kind of ties. (All thoroughly seasoned.)		Pounds required to pull spikes with various sizes of holes bored.					
		Common cut spike.			Screw spike.		
		No. hole.	$\frac{7}{8}$ in.	$\frac{1}{2}$ in.	$\frac{3}{8}$ in.	$\frac{1}{2}$ in.	$\frac{3}{4}$ in.
Red gum.....	Aver.	3265	3478	2872	2786	7,000	10,310
	Max.	3610	4230	3220	3195	7,080	10,570
	Min.	2580	2760	2490	2330	6,920	10,050
Red oak.....	Aver.	4120	3950	3265	2812	9,055	11,090
	Max.	4600	4320	3740	3300	9,470	12,170
	Min.	3700	3220	2700	2220	8,640	10,010
Pine, longleaf.....	Aver.	3583	3898	3215	2800	11,970	10,990
	Max.	4770	4200	3660	3710	13,450	11,660
	Min.	2400	3600	2900	2280	10,490	10,320
Pine, New Mexico...	Aver.	2285	1970	1190	1713	6,025	5,195
	Max.	2460	2210	1370	2220	6,660	5,770
	Min.	2020	1790	860	1000	5,300	4,620
Pine, shortleaf.....	Aver.	3323	3870	2275	2282	7,215	8,355
	Max.	3680	4580	2840	2640	8,680	9,290
	Min.	2870	2830	1920	2070	5,750	7,420
Douglas fir.....	Aver.	2883	3268	1928	2020	8,555	8,333
	Max.	3770	3820	2320	2080	9,010	9,040
	Min.	2290	2560	1570	1880	8,090	7,620
Balsam.....	Aver.	2968	2540	1913	1718	7,780	7,295
	Max.	4340	3640	2540	1840	9,900	9,000
	Min.	1980	1630	1280	1640	5,660	5,590
Ohia.....	Aver.	4315	6073	4207	3108	Could	18,010
	Max.	5010	7930	4950	4370	not screw	18,650
	Min.	3620	4910	3750	1400	spike in	17,370
Japanese oak.....	Aver.	6595	7650	4853	4760	Could	13,235
	Max.	8060	8370	6080	5210	not screw	13,280
	Min.	5120	6570	3630	4110	spike in	13,190

H. B. MacFarland, Eng. of Tests, A. T. &amp; S. Fé.

Common  $\frac{5}{8}$  in. cut spike, 9 $\frac{1}{2}$  ounces each or 169 spikes per 100 lbs. Screw  $\frac{7}{8}$  in. spike rolled V. thread  $\frac{1}{2}$  in. pitch; diam. at bottom of thread  $\frac{5}{8}$  in., 19 ounces each or 84 spikes per 100 lbs.

Cut spikes driven 4 $\frac{3}{4}$  in. deep with a maul under the four conditions mentioned. Screw spikes, holes were bored and the spikes screwed in for 5 in.

TABLE 93. — HOLDING POWER OF CUT AND SCREW SPIKES.

(Forest Service, Circular 46.)

Kind of timber.		Pounds required to pull spike.				Ratio of screw over common.	Condition of timber.
		Common spike.	No. of tests.	Screw spike.	No. of tests.		
Oak, white . . . . .	Aver.	6950	5	13,026	5	1.88	Partially seasoned
	Max.	7370		14,940			
	Min.	6160		11,050			
Oak, red . . . . .	Aver.	4342	5	11,240	8	2.61	Seasoned.
	Max.	5300		13,530			
	Min.	3490		8,900			
Pine, loblolly . . . . .	Aver.	3670	28	7,748	26	2.11	Seasoned.
	Max.	6000		14,680			
	Min.	2320		4,170			
Catalpa, hardy . . . . .	Aver.	3224	12	8,261		2.53	Green.
	Max.	4000		9,440			
	Min.	2190		6,280			
Catalpa, common . . . . .	Aver.	2887	11	6,939	11	2.42	Green.
	Max.	4500		8,340			
	Min.	2240		5,890			
Chestnut . . . . .	Aver.	2980	4	9,418	5	3.15	Seasoned.
	Max.	3220		11,150			
	Min.	2600		7,470			

In making a comparison of the holding power of cut spikes and screw spikes, the tables indicate that the screw spike has a holding power double to three times that of the cut spike. The least ratio of the screw spike over the common spike is 1.88 for white oak only partially seasoned but the majority of tests on seasoned as well as green timber give a ratio from 2.11 to 3.15 in favor of the screw spike. The reasons for and against screw spikes are discussed on page 198.

Ordinary track spikes are made of open hearth steel, heat treated, a sample of the spike usually being furnished by the manufacturer before the order is filled.

**Tie Plates.** — Tie plates increase the life of ties and prevent spreading of track, canting of rails and the cutting of ties by rail pressure, and excepting at joints are usually placed in pairs, one on each end of the same tie.

The first plates put into service were flat and thin and soon cupped and gave out under traffic; to strengthen the plate it was made heavier but the thicker metal cut the surface of both sides of the outside spike. To protect the spike a shoulder was introduced and the plate in this form was very satisfactory but it was found to rattle under traffic, when spikes were loosened. To overcome this trouble and at the same time to increase the lateral holding efficiency of the plate, ribs and other projections were inserted underneath. Deep ribs under the plate are said to be a source of weakness to the tie as it cuts into and destroys the fibers; for this reason and also to allow of shimming under the plate the ribs are made very low. Flat bottom plates are also used made extra heavy and sometimes with a camber to prevent rattling, and in some cases the plate is attached independently to the tie with lag screws.

When screw spikes are used almost invariably the plates are flat. The plates in use vary in size from 5 in.  $\times$  8 in.  $\times$   $\frac{3}{8}$  in., to 10 in.  $\times$  10 in.  $\times$   $\frac{1}{8}$  in., and the average weight per plate is about 7 lb.

To hold the tie plate to the tie and prevent movement between the plate and the tie, cut spikes are sometimes used independent of those that secure the rail, as shown, Fig. 60.

Screw spikes or lag screws are also used for this purpose, independent of the fastenings used to secure the rail. The standard tie plate on the P. L. & E. R. R., Fig. 61, cut spikes are used to secure the rail, and lag or screw spikes to hold the plate.

The Lundie tie plate with an inclined face is shown, Fig. 62.

Fig. 60a shows a screw spike tie plate with rail, D. L. & W. R. R.; the plate is held to the tie by lag screws. A hook shoulder tie plate used on the same road is shown, Fig. 61a; the plate is secured to the tie by screw spikes and the rail by a hook on one side and a screw or cut spike on the other.

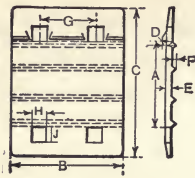

Typical 4 Hole.

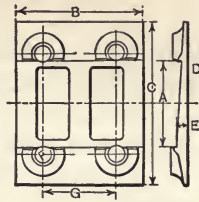

Typical 4 Hole.

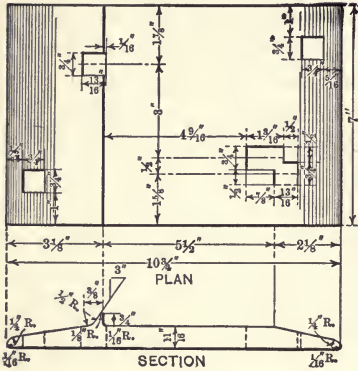

Fig. 60. Std. Tie Plate, P. R. R.

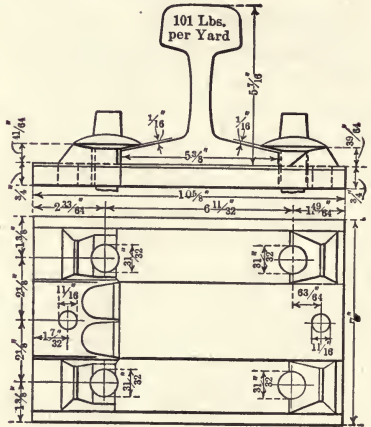

Fig. 60a. Screw Spike Tie Plate. D. L. & W.

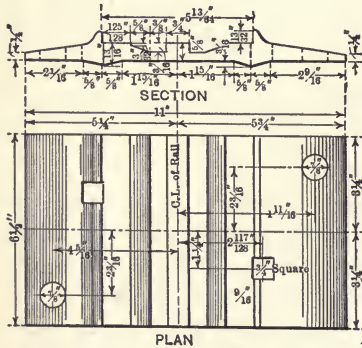

Fig. 61. Std. Tie Plate, P. L. & E. R.

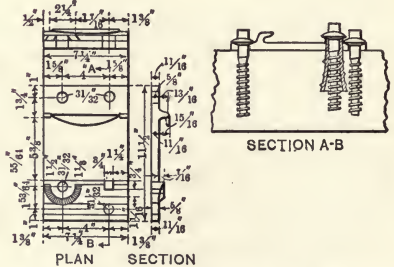

Fig. 61a. Hook Shoulder Tie Plate.

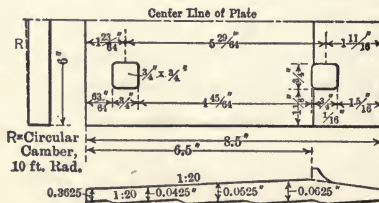

Fig. 62. Lundie Tie Plate.

TABLE 94. — TIE PLATES.  
SIZES USED BY A NUMBER OF RAILROADS.

Bearing area, sq. in.	Railroad.	Size.			Weight per plate, lb.	No. of ribs.	Number of ties per mile.		
		Width, in.	Length, in.	Thick-ness, in.			2800.	3000.	3200.
							Wt. per mile, lb.	Wt. per mile, lb.	Wt. per mile, lb.
40	N. Y. N. H. & H.....	5	8	$\frac{3}{8}$	4.9	4	27,500	29,400	31,360
41 $\frac{1}{2}$	Boston & Maine.....	5	8 $\frac{1}{2}$	$\frac{3}{8}$	5.3	4	29,680	31,800	33,920
51	Chicago & Alton.....	6	8 $\frac{1}{2}$	$\frac{3}{8}$	7.0	.....	39,200	42,000	44,800
51	M. St. P. & S. S. M....	6	8 $\frac{1}{2}$	$\frac{3}{8}$	5.6	Wol'r	31,360	33,600	35,840
51	Missouri Pacific.....	6	8 $\frac{1}{2}$	$\frac{1}{2}$	7.2	4	40,320	43,200	46,080
55 $\frac{1}{2}$	Canadian Pacific.....	6 $\frac{1}{2}$	8 $\frac{1}{2}$	$\frac{3}{8}$	6.2	4	34,720	37,200	39,680
59 $\frac{1}{2}$	Great Northern.....	7	8 $\frac{1}{2}$	$\frac{1}{2}$	7.8	4	43,680	46,800	49,920
63 $\frac{1}{2}$	Illinois Central.....	7 $\frac{1}{2}$	8 $\frac{1}{2}$	$\frac{7}{8}$	7.8	Sellers	43,680	46,800	49,920
67 $\frac{1}{2}$	A. T. & S. F.....	7 $\frac{1}{2}$	9	$\frac{1}{2}$	9.8	2	50,400	54,000	57,600
70	Union Pacific.....	8	8 $\frac{1}{2}$	$\frac{7}{8}$	6.6	Nil	36,960	39,600	42,240
70	Penn. — Lines west...	7	10	$\frac{1}{2}$	11.7	Nil	65,520	70,200	74,880
74 $\frac{1}{2}$	Penn. — Lines west...	7	10 $\frac{1}{2}$	$\frac{3}{8}$	11.8	Nil	66,080	70,800	75,520
100	Southern Pacific.....	8	8 $\frac{1}{2}$	$\frac{7}{8}$	6.6	Nil	36,960	39,600	42,240

## APPROXIMATE COST, C. P. R. TIE PLATES.

	Average, lb.	Per 100 lb.	Per plate, cents.
85 lb. rail shoulder tie plate.....	7	\$1.75	12 $\frac{1}{2}$
85 lb. rail taper tie plate.....	8	1.75	14
85 lb. rail Sellers bottom tie plate.....	6 $\frac{1}{2}$	1.75	11 $\frac{1}{2}$
85 lb. rail Sellers improved tie plate.....	7 $\frac{1}{2}$	1.75	13 $\frac{1}{2}$

With ordinary labor it costs from 5 to 10 cents per plate to put on tie plates. This includes adzing ties, plugging old holes, respiking and gauging.

**Turnouts.** — The turnout includes the switch, frog, guards, lead rails, etc., Fig. 63, and is the arrangement by which an engine and train pass from one track to the other.

A train approaching the turnout so as to pass the switch point first is said to "face" the switch, and when it approaches in the opposite direction, passing the frog first, it is said to "trail" the switch. To reduce the danger of derailment, especially on high speed main lines on double track, the turnouts are installed to trail the switches as far as possible.

Looking at the turnout from the switch towards the frog, the turnout is said to be "left-handed" when it turns out towards the left, and "right-handed" when it diverges towards the right.

A summary of the various items that go to make up a complete turnout, together with their approximate cost for a No. 7 and a No. 9 turnout, is as follows:

APPROXIMATE COST OF NO. 7 AND NO. 9 85-LB. TURNOUTS (SPRING FROGS).

Items.	New turnout.		Relaying all new rail.		Relaying second hand rail.	
	No. 7.	No. 9.	No. 7.	No. 9.	No. 7.	No. 9.
Switch and frog material . . .	\$114.12	\$127.74	\$95.90	\$109.52	\$95.90	\$109.52
Lead rail and fastenings . . . .	202.88	232.26	202.88	232.26	143.34	163.27
Ties, gravel ballast, etc. . . .	178.00	221.00	153.22	176.22	129.76	140.21
Total cost com. in place . . .	\$495.00	\$581.00	\$452.00	\$518.00	\$369.00	\$413.00

Deduct credit for any turnout removed.

The use of a rigid in place of a spring frog will reduce the total figure in each case by \$12.00.

The rails of the frog are always made straight.

The lead rail between the switch point and frog is curved to a circular arc which is tangent both to the switch rail and the wing rail.

For itemized statement of the foregoing figures showing in detail how the totals are arrived at for the turnouts see, page 210.



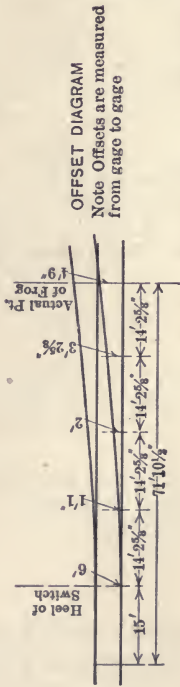
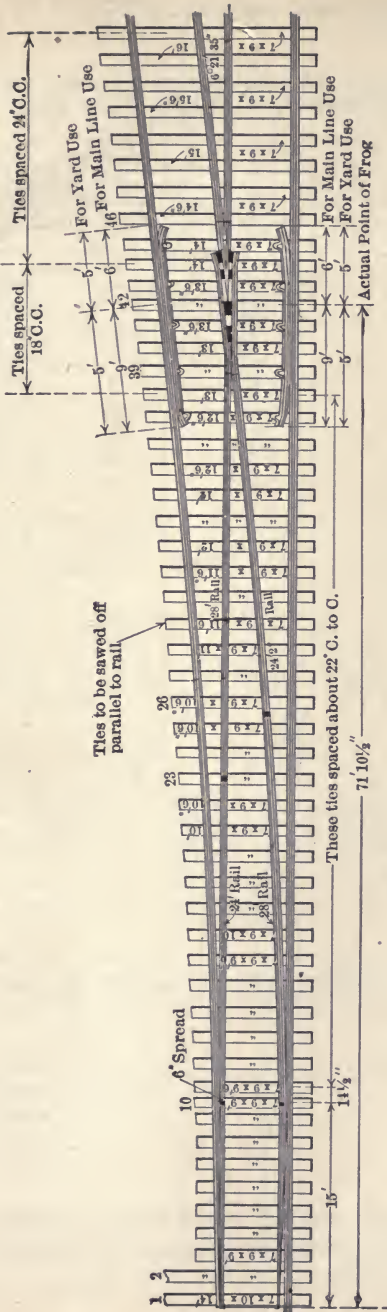

Fig. 63. Standard No. 9 Turnout, N. Y. C. & H. R. R. R.

APPROXIMATE COST OF A NO. 9 85-LB. TURNOUT WITH NEW RAIL,  
WITH RELAY RAIL AND WITH SECOND HAND RAIL.

Material.	85-lb. rail.		
	Cost of a new No. 9 turnout.	Relaying.	
		With all new rail.	With second hand rail.
<i>Switch and frog material:</i>			
2 switch points.....	\$22.90	\$22.90	\$22.90
2 heel castings.....	4.42	4.42	4.42
1 switch rod, No. 1.....	1.51	1.51	1.51
1 switch rod, No. 2.....	1.42	1.42	1.42
2 plate rods.....	2.34	2.34	2.34
1 set elevation plates.....	6.38	6.38	6.38
1 set rail braces.....	2.10	2.10	2.10
1 switch stand.....	12.95	.....	.....
1 spring frog.....	50.02	50.02	50.02
2 guard rails.....	7.15	7.15	7.15
2 guard rail center clamps.....	2.80	2.80	2.80
4 guard rail end clamps.....	3.26	3.26	3.26
1 switch lamp.....	3.75	.....	.....
1 lock.....	0.45	.....	.....
1 chain.....	0.21	.....	.....
	\$121.66	\$104.30	\$104.30
Stores charges 5 per cent.....	6.08	5.22	5.22
<i>Total switch and frog material.....</i>		\$127.74	\$109.52
<i>Rails and fastenings:</i>			
No. 9.			
5.43 tons rail.....	\$179.00	\$179.00	\$108.60
0.30 tons angle bars.....	13.50	13.50	13.50
0.03 tons bolts.....	2.36	2.36	2.37
0.20 tons spikes.....	10.40	10.40	10.80
200 tie plates.....	27.00	27.00	28.00
<i>Total rails and fastenings.....</i>		\$232.26	\$163.27
<i>Miscellaneous:</i>			
Ballast gravel, 120 cu. yd. (No. 9).....	\$60.00	.....	.....
Ties, 80 cu. yd. (No. 7).....	101.00	\$101.00	\$75.00
Labor laying turnout.....	60.00	60.00	50.00
Labor taking up old turnout.....	.....	15.22	15.21
<i>Total miscellaneous.....</i>		\$176.22	\$140.21
<i>Grand total.....</i>		\$581.00	\$413.00
Deduct proper credit for turnout removed.....	.....	?	?
<i>Final total.....</i>		\$581.00	?

From the foregoing it will be noted that the cost of a new No. 9 turnout is \$581 which may be briefly summarized as follows:

Switch and frog material.....	\$127.74
Rails and fastenings.....	232.26
Miscellaneous.....	221.00
<b>Total.....</b>	<b>\$581.00</b>

For relaying with all new rail, the cost is less on account of some of the items being on hand, and when second hand material is used the cost is reduced about 25%.

APPROXIMATE COST OF A NO. 7 85-LB. TURNOUT WITH NEW RAIL,  
WITH RELAY RAIL AND WITH SECOND HAND RAIL.

Material.	85-lb. rail.		
	Cost of a new No. 7 turnout.	Relaying.	
		With all new rail.	With second hand rail.
<i>Switch and frog material:</i>			
2 switch points.....	\$22.90	\$22.90	\$22.90
2 heel castings.....	4.42	4.42	4.42
1 switch rod, No. 1.....	1.51	1.51	1.51
1 switch rod, No. 2.....	1.42	1.42	1.42
2 plate rods.....	2.34	2.34	2.34
1 set elevation plates.....	6.38	6.38	6.38
1 set rail braces.....	2.10	2.10	2.10
1 switch stand.....	12.95	.....	.....
1 spring frog.....	37.05	37.05	37.05
2 guard rails.....	7.15	7.15	7.15
2 guard rail center clamps.....	2.80	2.80	2.80
4 guard rail end clamps.....	3.26	3.26	3.26
1 switch lamp.....	3.75	.....	.....
1 lock.....	0.45	.....	.....
1 chain.....	0.21	.....	.....
	\$108.69	\$91.33	\$91.33
Stores charges 5 per cent.....	5.43	4.57	4.57
<i>Total switch and frog material</i> .....	\$114.12	\$95.90	\$95.90
<i>Rails and fastenings:</i>			
No. 7.....	\$151.54	\$151.54	\$92.00
4.60 tons rails.....	11.25	11.25	11.25
0.25 tons angle bars.....	2.37	2.37	2.37
0.03 tons bolts.....	9.72	9.72	9.72
0.18 tons spikes.....	28.00	28.00	28.00
200 tie plates.....	\$202.88	\$202.88	\$143.34
<i>Total rails and fastenings</i> .....			
<i>Miscellaneous:</i>			
Ballast gravel, 120 cu. yd. (No. 9).....	\$40.00	.....	.....
Ties, 80 cu. yd. (No. 7).....	88.00	\$88.00	\$65.00
Labor for ying turnout.....	50.00	50.00	50.00
Labor taking up old turnout.....	.....	15.22	14.76
<i>Total miscellaneous</i> .....	\$178.00	\$153.22	\$129.76
<i>Grand total</i> .....	\$495.00	\$452.00	\$369.00
Deduct proper credit for turnout removed.....	.....	?	?
<i>Final total</i> .....	\$495.00	?	?

Note. — The use of a rigid instead of a spring frog would reduce the total \$12.00 in each case.

From the foregoing it will be noted that the cost of a new No. 7 turnout is \$495 which may be briefly summarized as follows:

Switch and frog material.....	\$114.12
Rails and fastenings.....	202.88
Miscellaneous.....	178.00
<b>Total.....</b>	<b>\$495.00</b>

For relaying with all new rail, the cost is less on account of some of the items being on hand, and when second hand material is used the cost is reduced about 25%.

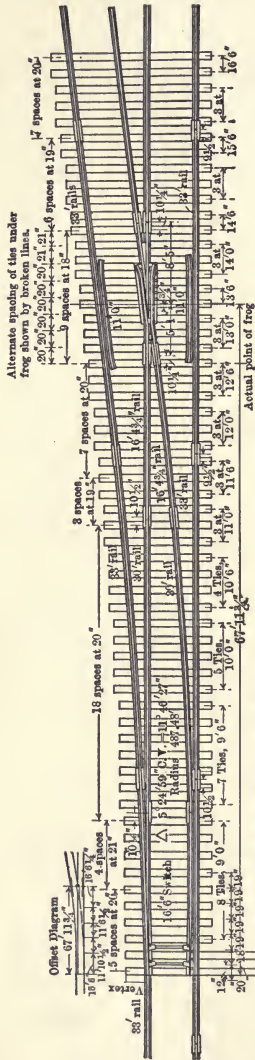

Fig. 64. A. R. E. A. Typical Plan No. 8 Main Line Turnout.

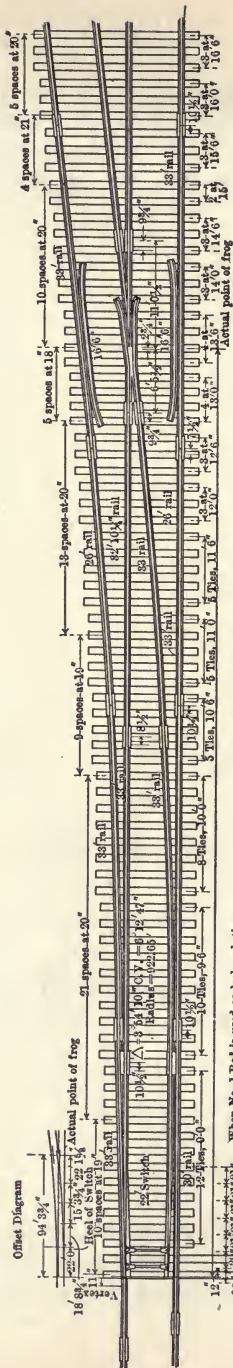

Fig. 65. A. R. E. A. Typical Plan No. 11 Main Line Turnout.

TABLE 95. — TABLE OF THEORETICAL AND PRACTICAL SWITCH LEADS.

(Amer. Ry. Eng. Assoc.)

In all cases gage is considered 4 ft. 8½ in.

Properties of frogs. Thickness of all frog points 0½ in.

<i>N</i> = frog number.	<i>F</i> = frog angle.			<i>W</i> = length point to toe.		<i>K</i> = length point to heel.		Total length.		Spread at toe.	Spread at heel.
I.	II.			III.		IV.		V.		VI.	VII.
	Deg.	Min.	Sec.	Ft.	In.	Ft.	In.	Ft.	In.	Feet.	Feet.
4	14	15	00	3	2	5	4	8	6	0.79	1.32
5	11	25	16	3	7	6	5	10	0	0.71	1.28
6	9	31	38	4	0	7	0	11	0	0.66	1.16
7	8	10	16	4	5	8	1	12	6	0.63	1.15
8	7	09	10	4	9	8	9	13	6	0.59	1.09
9	6	21	35	6	0	10	0	16	0	0.67	1.11
9½	6	01	32	6	0	10	0	16	0	0.63	1.05
10	5	43	29	6	0	10	6	16	6	0.60	1.05
11	5	12	18	6	0	11	6	17	6	0.54	1.05
12	4	46	19	6	5	12	1	18	6	0.53	1.01
15	3	49	06	7	8	14	10	22	6	0.51	0.99
16	3	34	47	8	0	16	0	24	0	0.50	1.00
18	3	10	56	8	10	17	8	26	6	0.49	0.98
20	2	51	51	9	8	19	4	29	0	0.48	0.97
24	2	23	13	11	4	23	2	34	6	0.47	0.97

<i>N</i> = frog number.	Properties of switches. For all switches thickness of point = 0½ in. and heel distance = <i>H</i> = 6½ in.								Theoretical leads.							
	<i>S</i> = length of switch rail.		<i>a</i> = switch angle.			<i>R</i> = radius of center line.		<i>D</i> = degree of lead curve.			Distance point of switch rail to theoretical point of frog.		Closure straight rail.		Closure curved rail.	
	I.	VIII.		IX.			X.		XI.			XII.		XIII.		XIV.
	Ft.	In.	Deg.	Min.	Sec.	Feet.		Deg. Min. Sec.			Feet.		Feet.		Feet.	
4	11	0	2	36	19	112.26		52	53	56	37.05		22.88		23.29	
5	11	0	2	36	19	183.22		31	40	24	42.77		28.19		28.55	
6	11	0	2	36	19	273.95		21	01	58	48.11		33.11		33.38	
7	16	6	1	44	11	364.88		15	47	19	61.94		41.02		41.24	
8	16	6	1	44	11	488.71		11	44	40	67.47		46.22		46.42	
9	16	6	1	44	11	616.27		9	18	27	72.24		49.74		49.92	
9½	16	6	1	44	11	699.97		8	11	33	74.90		52.40		52.58	
10	16	6	1	44	11	790.25		7	15	18	77.51		55.01		55.17	
11	22	0	1	18	8	940.21		6	05	48	92.06		64.06		64.20	
12	22	0	1	18	8	1136.34		5	02	38	97.25		68.83		68.96	
15	33	0	0	52	5	1744.38		3	17	01	133.02		92.36		92.46	
16	33	0	0	52	5	2005.98		2	51	24	135.95		94.95		95.05	
18	33	0	0	52	5	2587.66		2	12	52	146.38		104.54		104.61	
20	33	0	0	52	5	3262.98		1	45	22	156.35		113.68		113.76	
24	33	0	0	52	5	4932.77		1	09	42	175.09		130.66		130.77	

# 214 THEORETICAL AND PRACTICAL SWITCH LEADS.

TABLE 95 (Continued). — TABLE OF THEORETICAL AND PRACTICAL SWITCH LEADS.

In all cases gage is considered 4 ft. 8½ in.

Practical leads.										
N = frog number.	$R_1$ = radius of center line.	$D_1$ = degree of lead curve.			Rectangular co-ordinates to the quarter and center points on gage side of curved rail, referred to point of switch rail as origin.					
					X.	$X_1$ .	$X_2$ .	Y.	$Y_1$ .	$Y_2$ .
I.	XV.	XVI.			XVII.	XVIII.	XIX.	XX.	XXI.	XXII.
	Feet.	Deg.	Min.	Sec.	Feet.	Feet.	Feet.	Feet.	Feet.	Feet.
4	110.69	53	42	24	17.74	23.44	29.75	0.97	1.67	2.79
5	174.34	33	19	57	17.78	24.54	31.27	0.95	1.61	2.62
6	265.39	21	43	04	19.07	27.13	35.15	1.01	1.74	2.72
7	362.08	15	52	29	26.72	36.93	47.11	0.97	1.71	2.74
8	487.48	11	46	27	28.37	39.91	51.45	1.02	1.78	2.91
9	605.18	9	28	42	28.75	40.98	53.19	1.02	1.76	2.75
9½	695.45	8	14	45	30.31	43.35	56.37	1.06	1.82	2.83
10	790.25	7	15	18	30.28	44.05	57.81	1.06	1.84	2.85
11	922.65	6	12	47	40.74	56.47	72.19	1.08	1.84	2.87
13	1098.73	5	12	59	43.99	60.65	77.28	1.15	1.90	2.91
15	1744.38	3	17	01	55.49	77.95	100.41	1.01	1.78	2.85
16	1993.24	2	52	59	58.16	81.76	105.35	1.04	1.82	2.87
18	2546.31	2	14	31	58.73	84.46	110.10	1.04	1.82	2.86
20	3257.26	1	45	32	61.84	90.21	118.59	1.08	1.88	2.93
24	4886.16	1	10	21	67.82	100.21	132.59	1.27	1.97	3.00

Practical leads.

N = frog number.	$T_s$ = tangent adjacent to switch rail.	$T_f$ = tangent adjacent to toe of frog.	$L_1$ = distance actual point of switch rail to theoretical point of frog.	Lead = distance actual point of switch rail to actual point of frog.	Closure for straight rail.		Closure for curved rail.	
					XXVII.	XXVIII.		
I.	XXIII.	XXIV.	XXV.	XXVI.	XXVII.		XXVIII.	
	Feet.	Feet.	Feet.	Feet.				
4	1.03	0.00	37.77	37.94	1-23.60		1-24	
5	0.00	0.82	42.26	42.47	1-27.68		1-28	
6	0.00	0.66	47.73	47.98	1-32.73		1-33	
7	0.00	0.19	61.81	62.10	1-13.89	1-27	1-14.11	1-27
8	0.30	0.00	67.65	67.98	1-16.40	1-30	1-16.60	1-30
9	0.00	0.57	71.91	72.28	1-16.41	1-33	1-16.59	1-33
9½	0.76	0.00	75.32	75.71	1-25.82	1-27	1-26	1-27
10	0.00	0.00	77.51	77.93	1-27	1-28	1-27.17	1-28
11	2.99	0.00	93.85	94.31	1-32.85	1-33	2-33	
13	5.33	0.00	100.30	100.80	1-23.88	2-24	3-24	
15	0.00	0.00	132.66	133.28	2-33	1-25.9	2-33	1-26
16	1.56	0.00	136.90	137.57	1-29.90	2-33	1-30	2-33
18	0.00	1.08	145.76	146.51	1-25.93	3-26	4-26	
20	0.44	0.00	156.59	157.42	1-26.92	2-27	1-33	3-27
24	2.43	0.00	176.22	177.22	1-32.89	3-33	4-33	

**Switches.**— The switches in common use for turnouts are the stub and split or point switch. If the ends of the rails are cut off at a bevel so as to lap slightly when thrown it is called a lap switch.

The fixed end of the switch is called the heel, the movable end the toe; the heel is nearest the frog and the toe is practically the switch point; from toe to heel is the length of switch.

The throw is the distance over which the free end moves when thrown.

Turnout between switch and frog is usually made a simple circular curve.

*Stub Switch.*— The ordinary stub switch breaks the continuity of the main line in three places, two at the switch head block and one at the frog. Owing to the pounding of wheels over the open space, account settlement of head block, and to expansion and contraction of rail, rendering the joints tight in summer and open in winter, and the liability of derailment should a train trail the switch, their use has been practically abandoned except in isolated tracks in yards or at points seldom in service.

*Slip Switches.*— Slip switches are used where space is insufficient for ordinary turnouts or crossovers. Single slip is used when only one crossover track is required, double slips when two crossovers are necessary. The switches are operated simultaneously from a central "slip switch stand." Each end of a slip has a special twin split switch, which forms the entrance to the crossovers, each crossover containing one right and one left turnout. The A. R. E. A. recommended typical types of slip switches are shown, Fig. 73.

APPROXIMATE COST OF SWITCHES ONLY.

Switches.	Approximate cost.	Laying and surfacing.	Approximate cost.
New stub switch.....	\$25.00 to \$35.00	Stub switch.....	\$25.00 to \$35.00
New main line split.....	35.00 to 65.00	Main line switch (split)..	30.00 to 50.00
New main line slip switch (single)	60.00 to 80.00	Switches in large yards..	30.00 to 40.00
New main line slip switch (double)	70.00 to 100.00	Taking up and relaying switch .....	30.00 to 50.00
Tie rods (6).....	\$12 at 4¢ per lb.	Slip switch, single.....	50.00 to 70.00
Tie plates or rail braces 15¢ each..	\$2.70 per turnout	Slip switch, double.....	60.00 to 100.00

*Point Switches.* — 16½ ft. switch point is recommended by the A. R. E. A. for No. 8 frog; 22 ft. for No. 11 and 33 ft. for No. 16.

In choosing the length of a switch, it will be noted that the degree of turnout curve tends to increase as the switch length increases, with reference to a particular frog; the longer the switch length, however, the easier will be the change in direction for comfortable passenger service.

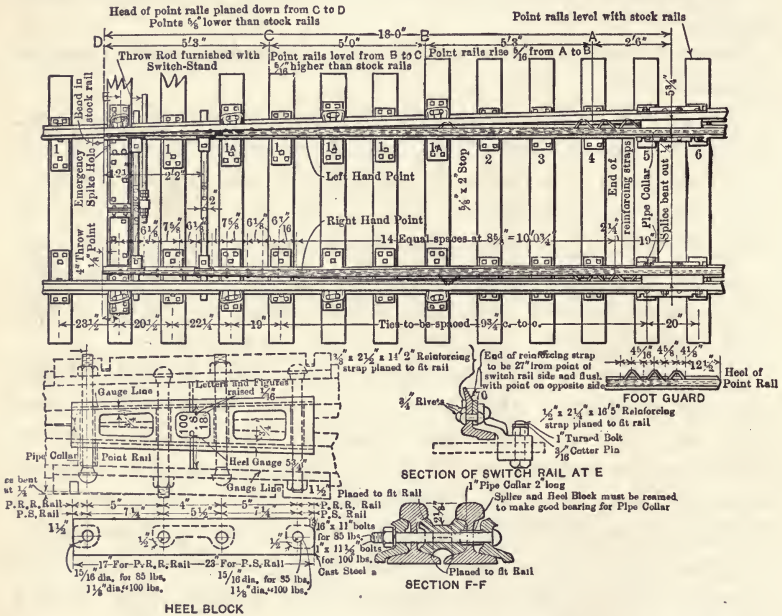

Fig. 66. P. R. R. Standard 18-ft. Point Switch for 85- and 100-lb. Rails.

BILL OF MATERIAL.

No. of pieces.	Description.
2	Switch point rails (with foot guards, sockets and bolts complete).
25	Switch plates (complete).
8	Adjustable braces (with bolts, nut locks, double nuts and malleable washers).
2	Rods (complete).
If heel blocks are desired the following must be included:	
2	Heel blocks (with bolts and pipe collars complete).
2	Splices (bent and reamed as shown).



From a theoretical standpoint, the ideal relation exists when the switch angle is no greater than one-fourth the frog angle, although quite satisfactory results are obtained when the ratio is as low as one to three and a half.

Usually the space available and service required, whether high or low speed, determines the number of frog and the length of switch most suitable for the frog selected.

No. 6 frog is usually the minimum permissible.

No. 8 frog is common for main track connections to spurs, set off sidings, yard ladders, etc., when speed in operating does not exceed 15 miles per hour.

No. 11 frog for main track turnouts and crossovers for moderate speed, and No. 16 where high speed is maintained.

*Switch Points.* — The reinforced high grade steel switch point rail is in general use for main line track. The purpose of reinforcing is to provide extra strength in case of breaks rather than to strengthen the switch point.

The cost of reinforcing is about \$1.25 per point extra.

For split switches in common use the reinforced point is recommended.

For yardwork at inside switches the manganese separable switch point is recommended.

No switch point shorter than 12 ft. should be used.

*Switch Stands.* — The switch stands in general use are of two types commonly called the rigid and automatic. The rigid stand has a positive connection between the stand and the switch so that when run through, the stand or the connecting rod to the stand will be broken or so damaged that it must be reported and repaired before it can be used again.

The automatic stand is equipped with a spring so that if run through, the points will automatically open and close without apparent damage to the switch connections; for this reason it is said to be an invitation to trainmen to go through without throwing the switch, as the spring permits them to do so without breaking the points or connecting rods; but in so doing the spring may be weakened and the point opened sufficient to endanger the next train passing in a facing point direction. Another objection to the spring is that anything falling on the switch from the train, or snow clogging the spring, will allow it

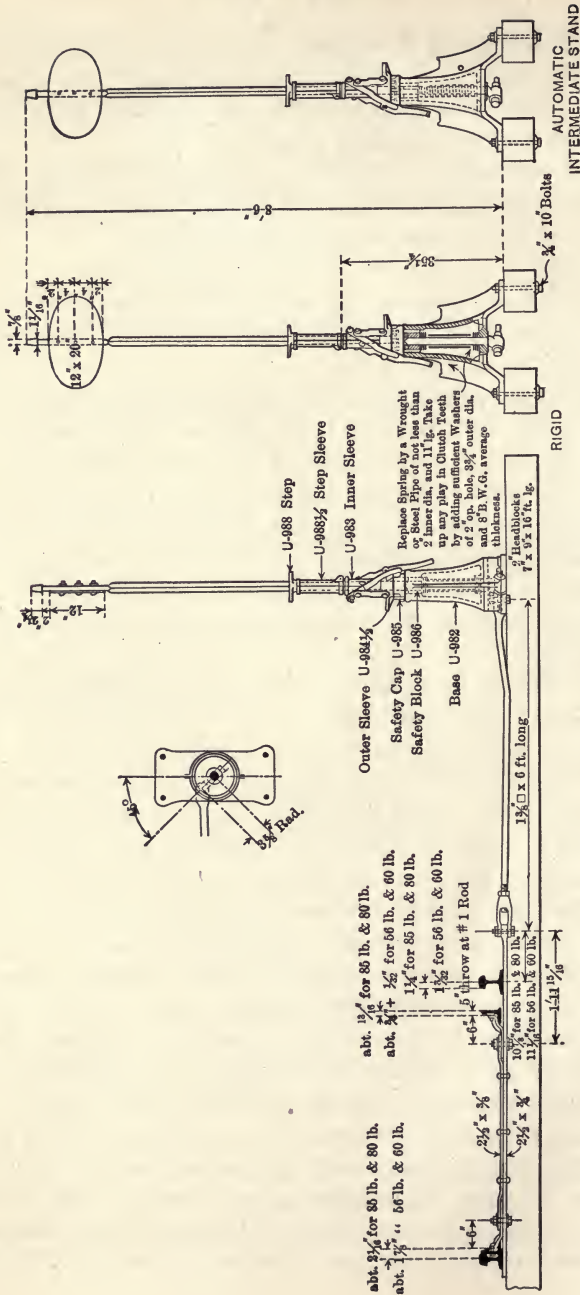

Fig. 66a. C. P. R. Rigid and Automatic Switch Stands.

to close although the points may not be precisely tight against the stock rail.

Approximate cost split switch stands only:

Automatic.....	\$14.00 to \$16.00
High.....	20.00 to 25.00
Intermediate.....	17.00 to 22.00
Low.....	10.00 to 15.00
Ramapo stub switch stand.....	9.00 to 16.00
Lamps.....	4.00 to 5.00
Lock and chain.....	0.50 to 0.75
Head chain (2).....	\$3 at 3½ cts. per lb.

The stand should be as simple as possible, preferably the shaft and lever should be a one-piece forging and the frame of malleable metal which twists rather than breaks.

The average cost of the rigid type of stand with target is \$11.00.

The average cost of the automatic type of stand with target is \$14.00.

A high switch stand should be used on all main line switches and a low stand for secondary tracks at stations, sidings and for the outside of ladder tracks.

For yard stands for inside switches and ladder tracks, a ground throw stand is preferred, designed so as to throw on a vertical plane parallel with the track instead of a horizontal plane. In this way danger to switchmen is reduced.

*Switch Targets.* — It is the practice to use the single target or stands showing no signals for a clear track except by a light at night.

Enameled targets are used to a great extent as they retain their brightness longer than painted targets.

The bull's-eye target with the light in the center is considered good practice for yard stands. It is usually not the practice to use lights or switch stands within 200 ft. of a semaphore. The use of a distinct color for the targets of secondary switches is quite common, yellow being the color usually adopted.

*Frogs.* — The frog is a device whereby the rail at the turnout curve crosses the main track rail, and is represented by Fig. 66b, with all the parts designated in the terms generally used.

Foot guards are inserted in the angle of frogs, heel of switches and ends of guard rails to protect employees from getting their feet caught.

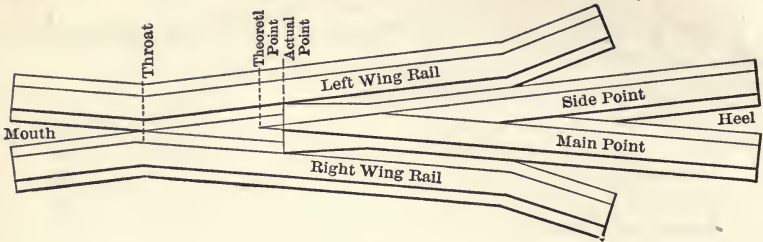

Fig. 66b.

The frog number is the proportion of its length into its breadth or spread. Frog angle =  $cb \div (ab + cd)$ .



Fig. 66c.

*Example.* —  $ab = 4$  inches,  $cd = 8$  inches,  $bc = 84$ .  $84 \div (8 \text{ inches} + 4 \text{ inches}) = 7$ . Angle or spread of frog is 1 in 7, or No. 7 frog.

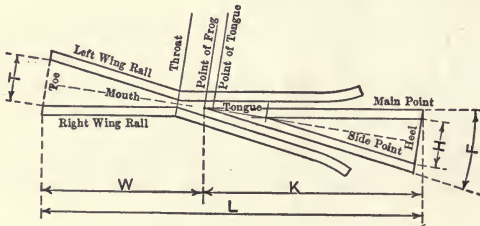

PROPERTIES OF FROGS.

Thickness of all frog points  $0\frac{1}{2}$  in. (4 ft.  $8\frac{1}{2}$  in. gage).

Frog number.	Frog angle.	Length of point to toe.		Length of point to heel.		Total length.	Spread at toe.	Spread at heel.
	F.	W.		K.		L.	T.	H.
	Deg. Min. Sec.	Ft.	In.	Ft.	In.	Ft. In.	Feet.	Feet.
7	8 10 16	4	5	8	1	12 6	0.60	1.15
8	7 09 10	4	9	8	9	13 6	0.59	1.09
9	6 21 35	6	0	10	0	16 0	0.67	1.11
10	5 43 29	6	0	10	6	16 6	0.60	1.05
11	5 12 18	6	0	11	6	17 6	0.54	1.05
12	4 46 19	6	5	12	1	18 6	0.53	1.01
15	3 49 06	7	8	14	10	22 6	0.51	0.99
16	3 34 47	8	0	16	0	24 0	0.50	1.00
18	3 10 56	8	10	17	8	26 6	0.49	0.98
20	2 51 51	9	8	19	4	29 0	0.48	0.97

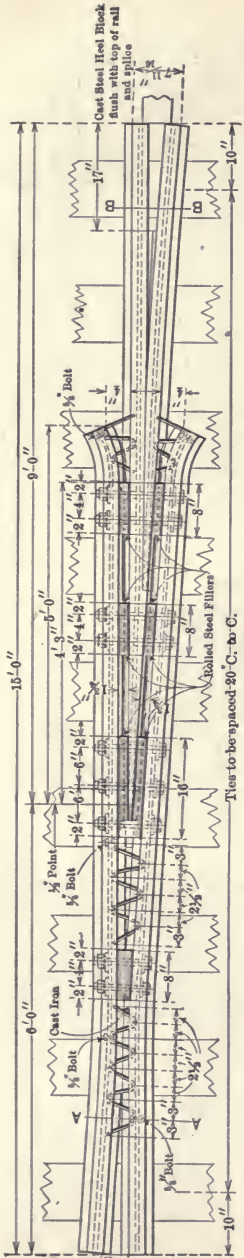

No. 15 FROG

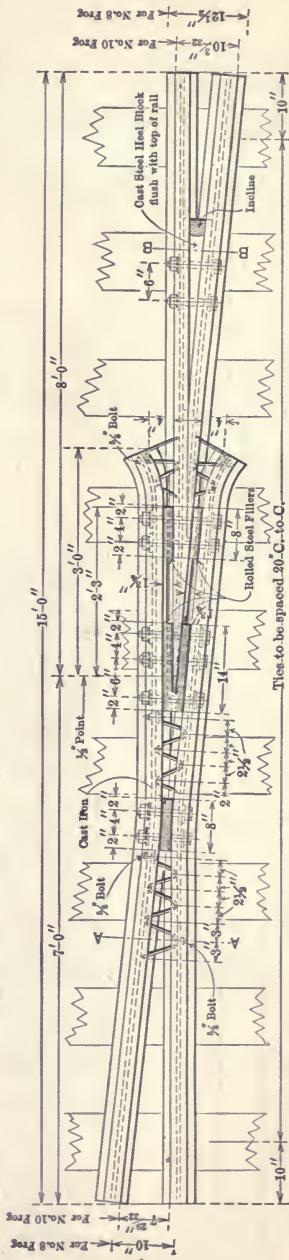

No. 8 & 10 FROGS

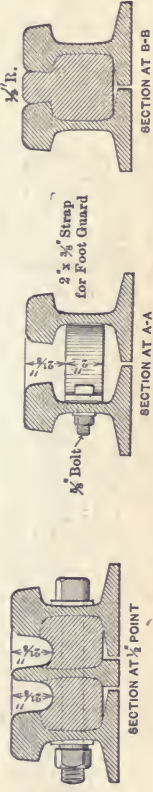

BOLTS	DIAM.
86 lbs. rails	1 1/4"
100 lbs. rails	1 1/2"

Fig. 67. P. R. R. Std. Rigid Frogs for 85-lb. and 100-lb. Rails.

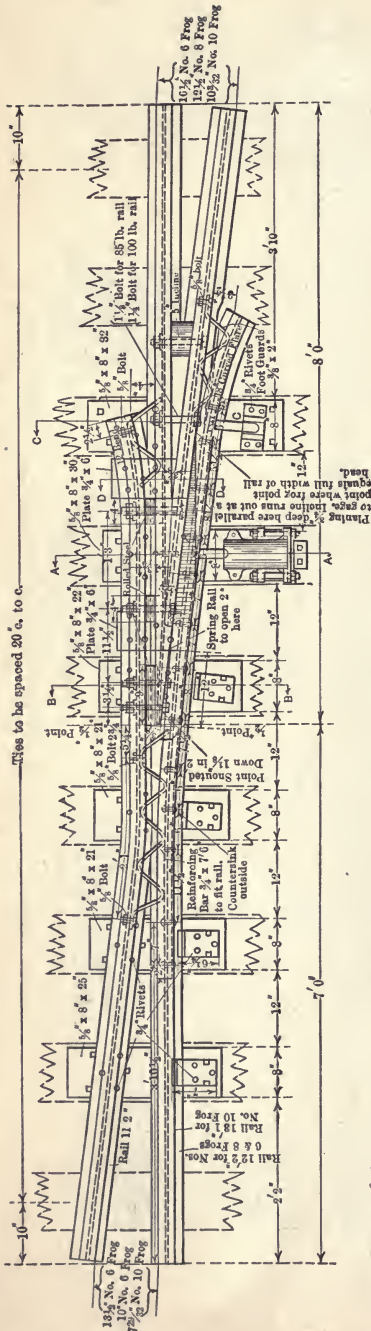

Fig. 68. P. R. R. Standard Spring Rail Frog.

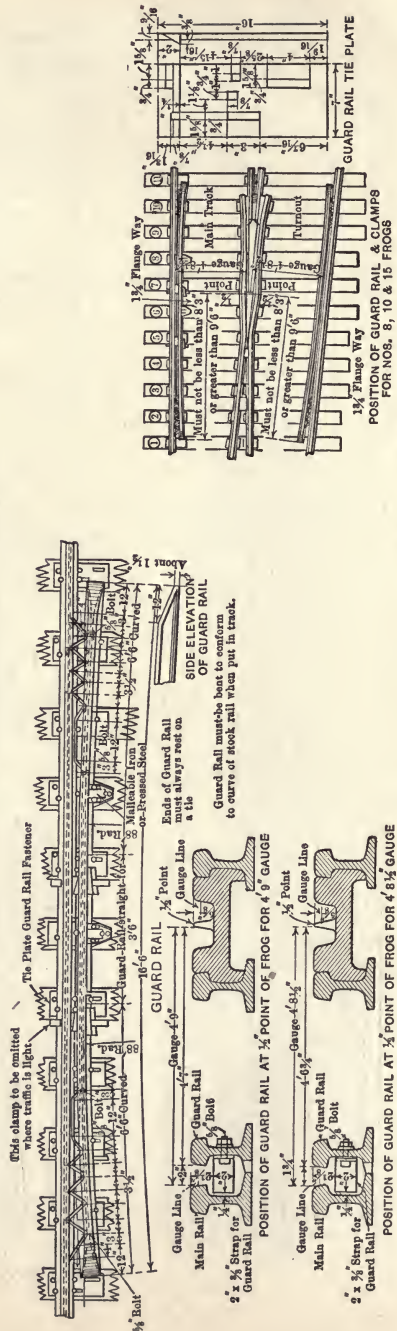

Fig. 68a. P. R. R. Guard Rail for 85-lb. and 100-lb. Rails.

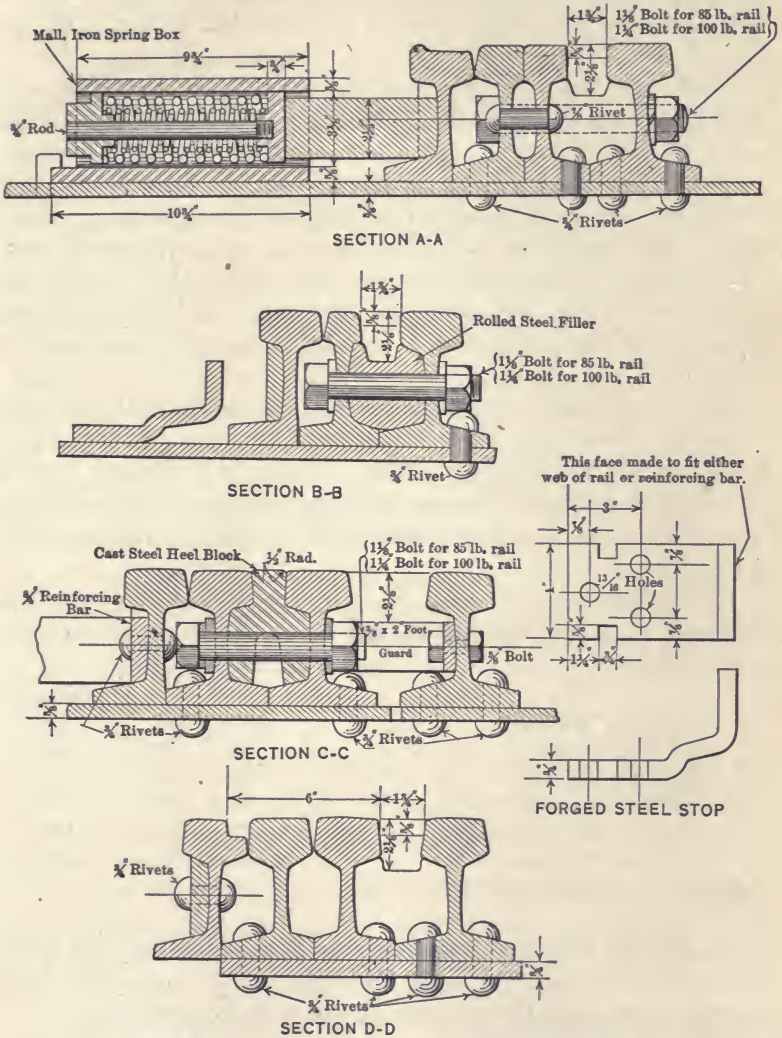

Fig. 69. P. R. R. Standard Spring Rail Frog.

Numbers 8, 11 and 16 frogs are recommended by the A. R. E. A. as meeting all general requirements for yards, main track switches and junctions, with 16½ ft. switch point for No. 8 frog, 22 ft. for No. 11, and 33 ft. for No. 16.

There are two types of frogs in general use, the rigid frog and the spring frog. Both are built up in a variety of different ways with bolts, clamps and rivets, and they are usually designated the bolted frog, the clamped frog, the riveted or plate frog from the method employed in their construction. There is also the manganese cast frog made of manganese steel, or a combination of the built-up frog with manganese inserts, the manganese being introduced at the point of greatest wear, usually the frog point and a facing for the wing rails at the throat.

The life of frogs is very variable, depending upon the amount of traffic, the quality of steel, its design and the amount of care and attention given to its up-keep. It has to withstand a series of shocks and if any looseness develops in its parts the resultant violent blows it has to withstand will soon destroy its usefulness for service.

For estimating purposes or as a comparison between the built-up type and the manganese frogs the following relative costs are given:

		Average
Spring frog, built-up.....	\$55 to \$65.....	\$60
Rigid frog, built-up.....	40 to 50.....	45
Spring frog, manganese insert.....	110 to 130.....	120
Rigid frog, manganese insert.....	80 to 120.....	100
Spring frog, solid manganese.....	150 to 210.....	180
Rigid frog, solid manganese.....	130 to 170.....	150
Cost of placing frog in track.....	6 to 10.....	8

During the life of an ordinary frog it is estimated that \$5.00 to \$10.00 is spent in tightening bolts and rivets more than would be spent on the maintenance of a manganese frog.

Solid manganese rigid frogs are recommended for busy terminals and switching leads where there is much traffic and where the Bessemer or open-hearth rail would wear out in less than one year, and manganese inserts at points of heavy wear and slow speed.



The length of a solid manganese frog is about three eighths the length of an insert frog which makes the solid frog a more easily handled article.

Comparing the ordinary steel rail frogs, generally designated as built-ups, with the cast manganese frogs, the principal feature is its probable economy due to the greater life of one over the other.

The first cost of an ordinary open-hearth 85-lb. steel, built-up No. 9 spring frog, which can be used as a comparison, is approximately \$65.00 in place, and the cost of the same frog in cast manganese steel may be estimated at \$165.00 in place. This comparison makes the ratio of price about 2.6 to 1.

The service of the ordinary steel frog is very variable, depending on its quality, design and up-keep, traffic, etc.; in many situations it might not last six months, but where conditions are favorable it may last six years and more.

The service of the best kind of manganese frog in situations where built-ups have lasted less than two years is known to be at least six years under fairly heavy traffic conditions. On the other hand, as the result of poor material many manganese frogs have lasted but a few months longer than the ordinary built-up frog which they replaced. When buying manganese frogs, it is not uncommon to have the makers guarantee them for at least five years, or to outlast the built-ups which they replace three to one.

In general it may be stated that the best kind of manganese cast steel frogs will outlast the ordinary built-up frogs, three to one (some go as high as 6 to 1) in situations where the latter does not last two years.

Frogs should be installed with the greatest care and should be well ballasted, preferably in stone throughout, the drainage should be given particular attention and ties should be spaced to insure as far as possible continuous bearings.

In making comparative prices for the built-up and manganese frogs, the cost figures are those in vogue previous to 1915. Since that time however prices have increased at least 50% and manganese, on account of lack of competition, has gone very much higher and can hardly be obtained at a reasonable price.

**Crossovers.**— A crossover is installed when it is desired to connect two parallel tracks, and consists of two turnouts connected by a short piece of straight track (Fig. 70). Where space is not available and the movements are slow, it is connected practically as reversed curves.

On double track the crossover is usually installed so as to avoid facing point switches, the movement being backward when the crossing is used, and trailing for main line movement.

The length depends upon the distance between tracks and the frog number.

The distance between frog points measured along one of the parallel tracks and the over-all length of crossovers can be obtained from the following table:

TABLE 96.

Distance B-B between frog points in feet.					Distance over all from switch point to switch point in feet.				
Frog No.	Distance between track centers.				Distance between track centers.				Turnout lead, ft.
	12 ft.	13 ft.	14 ft.	15 ft.	12 ft.	13 ft.	14 ft.	15 ft.	
6	14.5	20.46	26.42	32.38	110.46	116.42	122.38	128.34	47.98
7	17.07	24.04	31.00	37.96	141.27	148.24	155.20	162.16	62.10
8	19.62	27.59	35.56	43.53	155.58	163.55	171.52	179.49	67.98
9	22.16	31.13	40.10	49.07	166.72	175.69	184.66	193.63	72.28
10	24.70	34.68	44.66	54.64	180.56	190.54	200.52	210.50	77.93
11	27.22	38.20	49.18	60.16	215.84	226.82	237.80	248.78	94.31
12	29.75	41.73	53.71	65.69	231.35	243.33	255.31	267.29	100.80
15	37.30	52.28	67.26	82.24	303.86	318.84	333.82	348.80	133.28
16	39.81	55.80	71.79	87.78	314.95	330.94	346.93	362.92	137.57
18	44.83	62.82	80.81	98.80	337.85	355.84	373.83	391.82	146.51
20	49.85	69.84	89.83	109.82	364.69	384.68	404.67	424.66	157.42

## RELATIVE SPEEDS THROUGH LEVEL TURNOUTS (A. R. E. A.).

To give the EQUIVALENT RIDING CONDITIONS TO TRACK ELEVATED THREE INCHES  
LESS THAN THEORETICALLY REQUIRED.

Turnout.		Speed, miles per hour.
Frog number.	Length of switch.	
7	16.5	17
8-10	16.5	20
11-14	22	27
15	33	37
16-24	33	40

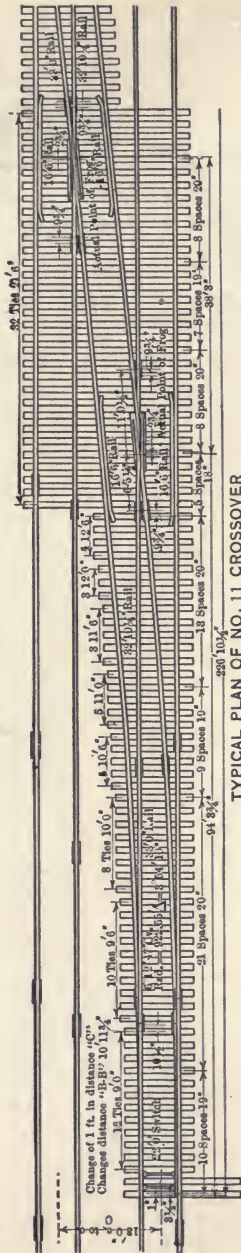

TYPICAL PLAN OF NO. 11 CROSSOVER

Fig. 70.

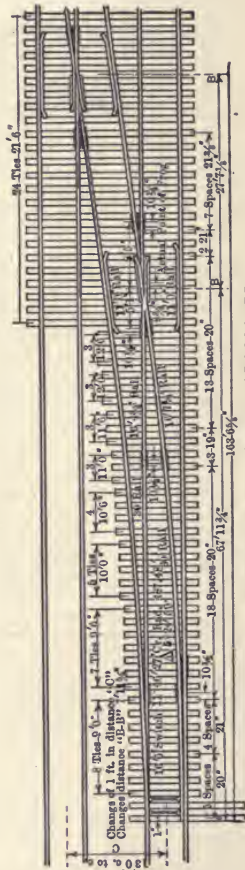

TYPICAL PLAN OF NO. 8 CROSSOVER

Fig. 71.

Turnout and Slip Switch Ties.

BILL OF MATERIAL FOR A. R. E. A. SLIP SWITCH TIES.

No. 8. DOUBLE SLIP. F. B. M. 5828.

80 pieces.		Bill of material of ties.					
	Ties.		Ties.		Ties.		Ties.
10	7''×9''×11' 0''	6	7''×9''×13' 0''	6	7''×9''×15' 0''	12	7''×9''×16' 6''
10	7''×9''×11' 6''	4	7''×9''×13' 6''	4	7''×9''×15' 6''	.....	.....
2	7''×9''×12' 0''	6	7''×9''×14' 0''	6	7''×9''×16' 0''	.....	.....
6	7''×9''×12' 6''	4	7''×9''×14' 6''	4	7''×9''×16' 6''	.....	.....

No. 11. DOUBLE SLIP. F. B. M. 7182.

100 pieces.		Bill of material of ties.				B/M.	
	Ties.		Ties.		Ties.		Ties.
14	7''×9''×11' 0''	8	7''×9''×13' 0''	4	7''×9''×15' 0''	12	7''×9''×16' 6''
12	7''×9''×11' 6''	8	7''×9''×13' 6''	6	7''×9''×15' 6''	.....	.....
6	7''×9''×12' 0''	6	7''×9''×14' 0''	6	7''×9''×16' 0''	.....	.....
6	7''×9''×12' 6''	6	7''×9''×14' 6''	6	7''×9''×16' 6''	.....	.....

No. 16. DOUBLE SLIP. F. B. M. 10,064.

150 pieces.		Bill of material of ties.				B/M.	
	Pieces.		Ties.		Ties.		Ties.
18	7''×9''×10' 6''	8	7''×9''×12' 6''	8	7''×9''×14' 6''	10	7''×9''×16' 6''
10	7''×9''×11' 0''	10	7''×9''×13' 0''	10	7''×9''×15' 0''	12	7''×9''×16' 6''
22	7''×9''×11' 6''	10	7''×9''×13' 6''	10	7''×9''×15' 6''	.....	.....
4	7''×9''×12' 0''	10	7''×9''×14' 0''	8	7''×9''×16' 0''	.....	.....

No. 8. MAIN LINE TURNOUT.

Bill of material. 58 pieces. 3651' B. M. 8' 6'' track tie.

P'ces.		P'ces.		P'ces.		P'ces.	
8	7''×9''× 9' 0''	3	7''×9''×11' 0''	3	7''×9''×13' 0''	5	7''×9''×15' 0''
7	7''×9''× 9' 6''	3	7''×9''×11' 6''	2	7''×9''×13' 6''	2	7''×9''×15' 6''
5	7''×9''×10' 0''	3	7''×9''×12' 0''	3	7''×9''×14' 0''	3	7''×9''×16' 0''
4	7''×9''×10' 6''	3	7''×9''×12' 6''	2	7''×9''×13' 6''	2	7''×9''×16' 6''

Bill of material. 56 pieces. 3336' B. M. 8' 0'' track tie.

P'ces.		P'ces.		P'ces.		P'ces.	
8	7''×9''× 8' 6''	3	7''×9''×10' 6''	3	7''×9''×12' 6''	3	7''×9''×14' 6''
7	7''×9''× 9' 0''	3	7''×9''×11' 0''	2	7''×9''×13' 0''	4	7''×9''×15' 0''
5	7''×9''× 9' 6''	3	7''×9''×11' 6''	3	7''×9''×13' 6''	3	7''×9''×15' 6''
4	7''×9''×10' 0''	3	7''×9''×12' 0''	2	7''×9''×14' 0''	.....	.....

No. 11. MAIN LINE TURNOUT.

Bill of material. 78 pieces. 4814' B. M. 8' 6'' track tie.

P'ces.		P'ces.		P'ces.		P'ces.	
12	7''×9''× 9' 0''	5	7''×9''×11' 0''	4	7''×9''×13' 0''	4	7''×9''×15' 0''
10	7''×9''× 9' 6''	5	7''×9''×11' 6''	4	7''×9''×13' 6''	3	7''×9''×15' 6''
8	7''×9''×10' 0''	3	7''×9''×12' 0''	3	7''×9''×14' 0''	3	7''×9''×16' 0''
5	7''×9''×10' 6''	3	7''×9''×12' 6''	3	7''×9''×14' 6''	3	7''×9''×16' 6''

Bill of material. 75 pieces. 4363' B. M. 8' 0'' track tie.

P'ces.		P'ces.		P'ces.		P'ces.	
12	7''×9''× 8' 6''	5	7''×9''×10' 6''	4	7''×9''×12' 6''	2	7''×9''×14' 6''
10	7''×9''× 9' 0''	5	7''×9''×11' 0''	4	7''×9''×13' 0''	5	7''×9''×15' 0''
8	7''×9''× 9' 6''	3	7''×9''×11' 6''	3	7''×9''×13' 6''	3	7''×9''×15' 6''
5	7''×9''×10' 0''	3	7''×9''×12' 0''	3	7''×9''×14' 0''	.....	.....

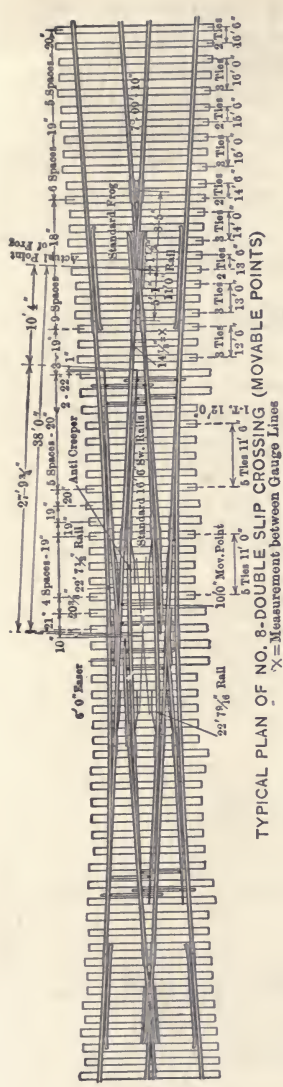

TYPICAL PLAN OF NO. 8-DOUBLE SLIP CROSSING (MOVABLE POINTS)  
X = Measurement between Gauge Lines

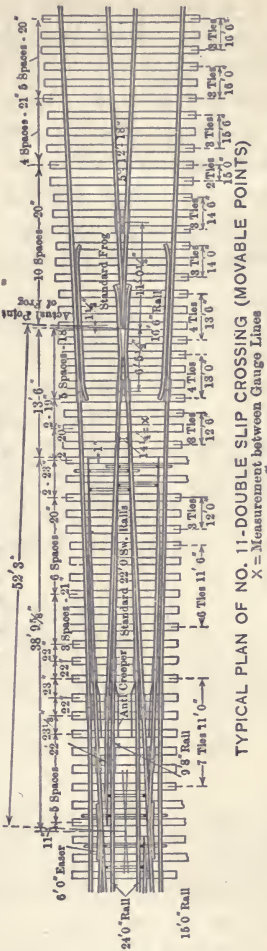

TYPICAL PLAN OF NO. 11-DOUBLE SLIP CROSSING (MOVABLE POINTS)  
X = Measurement between Gauge Lines

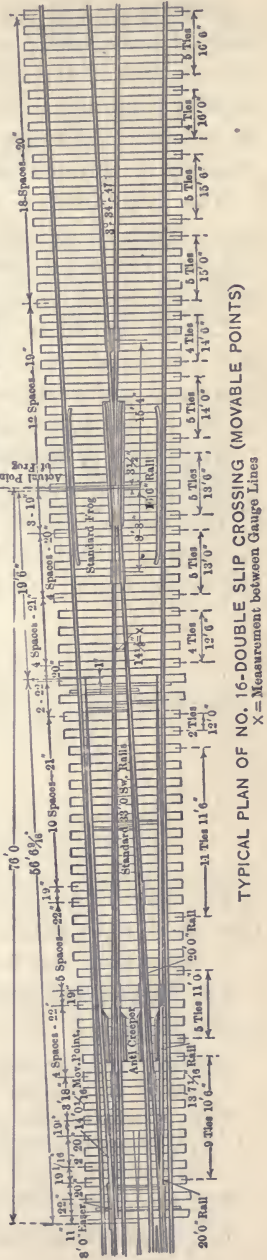

TYPICAL PLAN OF NO. 16-DOUBLE SLIP CROSSING (MOVABLE POINTS)  
X = Measurement between Gauge Lines

Fig. 72. A. R. E. A. Typical Double Slip Crossings.

**Derails.** — Derails are used generally for the protection of main tracks where a siding, which may be used for standing cars, comes off the main track or any other track leading thereto, having a gradient of 0.2 per cent or over toward the main line, so located that there is danger of a runaway car getting either directly or through an intervening siding to a main track.

The type used is generally that having an operating stand and target of its own, but in special cases where deemed advisable, the type having a target stand only and interlocked with the switch is used.

Derails should be located so that derailed cars shall not foul the protected track, and the distance of the derail from the clearance point should be carefully considered with reference to the probable distance a car would run after being derailed.

Retaining or deflecting guard rails are used in special cases where deemed advisable.

The terms "Right" and "Left" hand derail mean a derail deflecting to the right or left in the direction which a derailed car would move. (Fig. 73.)

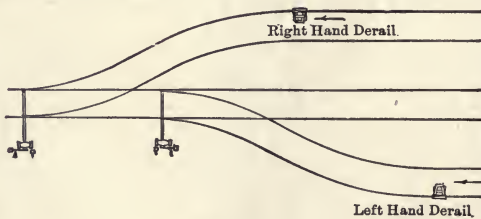

Fig. 73.

The following is an illustration of the method of determining the speed of a runaway car at the derail.

A car is standing on a siding 450 ft. from the derail.

The fall of the track to the derail is 5.06. Between these points there is 2° 00' curve 200 ft. long.

Rolling friction equals 0.3 ft. per 100 ft. of travel, or in 450 ft. it is  $4.50 \times 0.3 \dots \dots \dots$  1.35 ft.

Curve resistance equals 0.04 ft. per 100 ft. of travel per degree of curve, or in 200 ft. of 2°00' curve it is  $2 \times 2 \times 0.04 \dots \dots \dots$  0.16 ft.

Total resistance expressed in feet of fall.  $\dots \dots \dots$  1.51 ft.

The effective fall is  $5.06 - 1.51 \dots \dots \dots$  3.55 ft.

Let  $V$  = the speed of the car and  $h$  = the effective fall, then the general formula is

$$V^2 = h \div 0.0355.$$

In this case

$$V^2 = 3.55 \div 0.0355 = 100,$$

$$V = 10 \text{ miles per hour,}$$

the speed of the car at the derail.

The proximity of other tracks, structures, embankments and curvature of the track must also be considered.

Formula for impact of cars under four different conditions are given by the A. R. A. Assoc. as follows:

IMPACT OF CARS.  
CONSIDERING CARS AS INELASTIC BODIES.

CASE 1, -BOTH CARS MOVING IN SAME DIRECTION

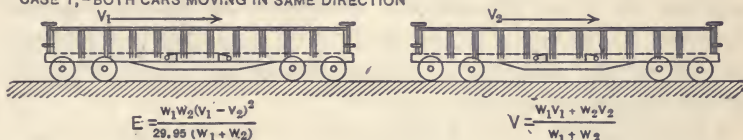

CASE 2, -CARS MOVING TOWARD EACH OTHER

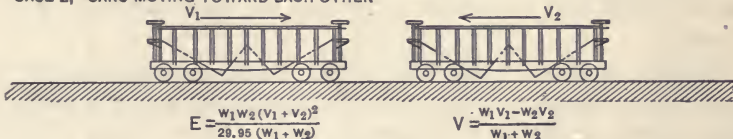

CASE 3, -ONE CAR STANDING STILL

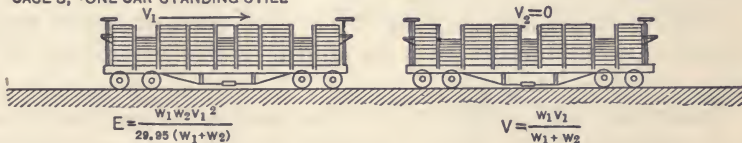

CASE 4, -ONE CAR STRIKING AN IMMOVABLE BODY

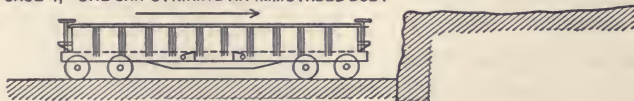

$$E = .0334 W V^2$$

$W_1$  = weight of one car in pounds.

$V_1$  = velocity of one car in miles per hour.

$W_2$  = weight of other car in pounds.

$V_2$  = velocity of other car in miles per hour.

$E$  = energy of impact in foot pounds.

$V$  = resulting velocity of both cars in miles per hour.

**Bumping Posts, Car Stops, etc.** — The type of stop or post to be used should be carefully considered for each case.

For tracks ending in a cutting or at unimportant points where there is little or no grade, the frame car stop, Fig. 77, may be used.

For tracks at about ground level where there is little or no grade and no better protection is necessary, an earth or cinder stop, Fig. 75, is used.

Where the side space is limited the sand car stop, Fig. 78, is used.

For passenger stub tracks in stations and yards on a level the cast iron stop, Fig. 74, is generally used.

Where sidings end on an embankment or trestle or have buildings or other damageable structures at the end thereof, rendering it necessary to positively stop a car for the safety of the car or the property adjoining the siding, a bumping post should invariably be used.

Too frequently the bumping posts in use are badly chosen, and often the damage caused by them is much greater than would be the cost of pulling a derailed car onto the track occasionally.

*Frame Car Stop.* (Fig. 77.) — The frame car stop should be used in cuts where the excavated embankment forms a natural stop, or for tracks at unimportant points where there is little or no grade.

*Earth or Cinder Stop.* (Fig. 75.) — The earth or cinder stop should be used when there is no need of better protection, and there is little or no grade.

*Sand Car Stop.* (Fig. 78.) — The sand car stop should be used where the side space is limited, and there is no need of better protection and there is little or no grade.

*Cast Iron Stop.* (Fig. 76.) — The cast iron stop should be used principally for protection of passenger car tracks in stations and yards on a level or nearly level grade.

*C. P. R. Bumping Post.* (Fig. 74.) — This bumping post is to be used only when necessary for the protection of person or property, and when it is absolutely essential to stop the car rather than have it run over the end of track.





Steel Bumping Post, D. L. & W. R. R. (Fig. 79.) — It is built entirely of structural steel shapes and rests on a concrete bed to which it is securely anchored by twenty 1½-in. bolts. The bottom ties are 15-in. 55-lb. channels about 15 ft. 6 in. long bedded in concrete laid over the foundation. These are said to provide a stable base, and the upright bracket which carries the rubber bumper block is strongly reinforced with stiffening angles in the direction of the resultant forces under impact.

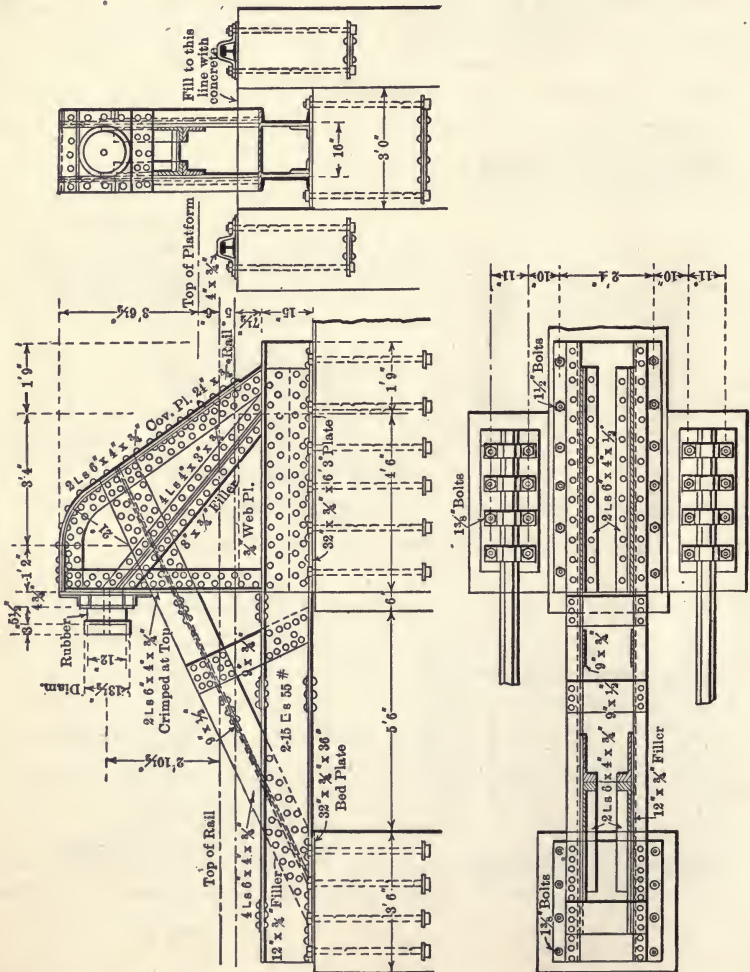

Fig. 79. Details of Steel Bumping Post in Hoboken Terminal of D. L. & W. R. R.

**Diamonds.** — The present day crossings, where traffic amounts to anything, are usually made of manganese steel, cast in two or more pieces. Where traffic is very light, built-up rail crossings of heavy steel are quite common.

It is well known that the pounding of rolling stock over a crossing is very destructive and if any looseness develops in any part of the crossing it is soon rendered unfit for service. It is essential, therefore, that the crossing be made of as few parts as possible, that the rails are deep and stiff and the connections made rigid so that no looseness shall develop under ordinary care and wear.

Standards for manganese crossings of various types for varying conditions and angles have been developed by the manganese track society which are followed pretty closely by the various manufacturers.

It is usual for the railway, in manganese work, to contract for their crossing work and plans are submitted for their approval by the makers, and the results chiefly depend on the workmanship and quality of the cast manganese as well as proper installation and maintenance.

To further strengthen crossings of this kind, foundations of concrete and steel directly under the crossing have been used in one or two cases, as an additional effort to get better riding track with less noise and wear.

*Cost.* — The cost will depend upon their weight, kind of angle and type of rail. There is very little difference in recent figures between the cost of a solid manganese and a built-up with manganese inserts. The following figures are some recent prices for manganese and built-up crossing, f. o. b. cars for the material.

One solid manganese 85-lb. diamond, 18°.....	\$740
One solid manganese 85-lb. diamond, 30°.....	850
One solid manganese 85-lb. diamond, 60°.....	809
One built-up 85-lb. diamond, 56°.....	235
One built-up with manganese inserts, 85-lb. diamond, 20°....	719
Two solid manganese 85-lb. diamonds.....	\$1000 to \$1250
Four solid manganese 85-lb. diamonds.....	\$2100 to \$2500

**Interlockers.** — On the assumption that all trains approaching a grade crossing would be required to come to a stop before

proceeding over the crossing, unless the crossing is protected by interlocking, it is figured that 12 trains a day, aside from the safety of interlocking, would justify its installation. The figures are as follows:

*Estimated yearly cost of interlocking.*

Cost of interlocking single track (16 levers) (Fig. 80).....	\$6000
Interest on cost, 5 per cent.....	\$300.00
Depreciation, 7 per cent.....	420.00
Maintenance.....	270.00
Operation.....	1200.00
Total cost per annum.....	\$2190.00 or \$6.00 per day

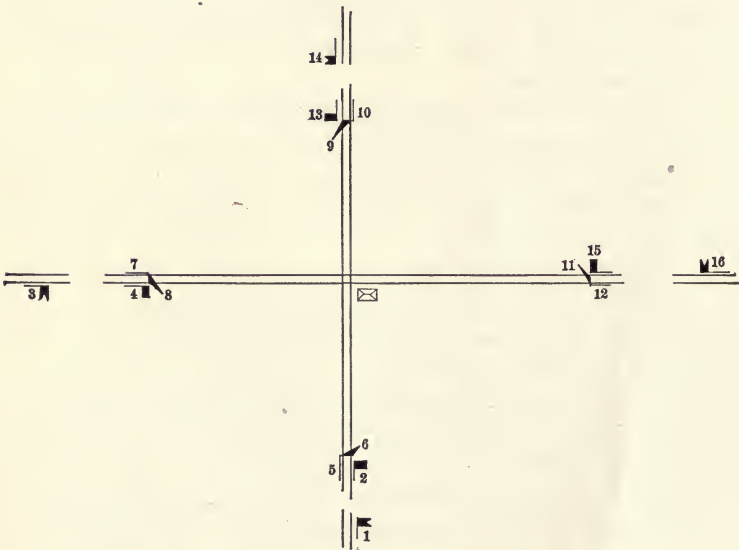

Fig. 80. Interlocked Single-track Lay-out.

Figuring that it costs 50 cents to stop a train and again accelerate it to its original speed, 12 trains would be \$6.00 per day or the equivalent of what it would cost to install and operate an interlocker. Where there are more than 12 trains there would be a corresponding saving.

**Interlocking Tower, Montclair, N. J., D. & W. R. R.** (Fig. 81.) — The signal tower is a two-story concrete structure with a basement. The tower plans show the end, the front, and rear



elevations, and also the floor plans. The basement plan shows the locations of the power equipment which consists of duplicate air compressors driven separately by three-phase 60-cycle induction motors, rated at 1800 R P.M. The air compressors are of the four-cylinder two-stage type, each compressor having a capacity of 100 cu. ft. per minute. The motors are controlled from the switchboard with an external starting resistance connected into the rotor circuit.

The motor generator sets, of which there are three, consist of three-phase 60-cycle 220-volt motors with shunt wound generators, rated at 75 amperes and 15 volts. These sets are of the unit frame type and furnish energy for charging storage battery.

The storage battery consists of four sets of Edison A-10 cells. Two sets of 16 cells each furnish energy for the interlocking apparatus as follows: for the control of switches, signals, and various indicator and annunciator circuits. One set of battery is for on and one set for off duty. Two sets of four cells each furnish energy for 32 track circuits on the plant.

The approximate cost of this tower (without equipment) under ordinary conditions is estimated to be \$3900.

## CHAPTER XI.

## BALLAST.

The material placed on the roadbed for the purpose of holding the track in line and surface is called ballast, and commonly consists of broken stone, gravel, cinders, sand, slag, or other material, depending on what is most available or expedient.

It is essential that the material selected should drain readily and the ballast section should be such as to distribute the bearing of the ties and insure a uniform pressure on the subgrade with reference to the volume and character of traffic, the climatic conditions, the nature of the subgrade itself and the spacing of the ties.

To produce a uniform pressure on the subgrade with the ordinary tie it is stated that 24 in. of ballast under the tie is necessary, but for a cushion only on a solid roadbed 12 in. is sufficient. The general ballast sections in use, however, vary from 7 in. to 12 in. in depth under the tie, and are of two types, the square section and the rounded section or a combination of both.

The principal kinds of ballast generally used today as described by Mr. E. A. Hadley are earth, cinders, gravel, chatts, burnt clay, furnace slag and broken stone. Dirt ballast or earth is easily worked in dry weather, but it is difficult to keep up the track with it in wet weather, and it also has a heavy growth of grass and weeds. It is dusty in dry weather and it reduces the life of the ties by decay at the ground line and causes broken ties in the winter by the earth heaving. Gravel is a ballast which increases the life of the tie and makes it possible to maintain good track. It is comparatively free from weeds, especially washed gravel from streams. It is also fairly free from dust. Chatt ballast is the refuse from lead and zinc mines from which the metal has been extracted, and is really finely crushed stone. It almost entirely destroys vegetation, and if not too fine is practically dustless. It is easily worked and gives a neat appearance to the track.

BALLAST SECTIONS.

Crushed Stone or Slag.

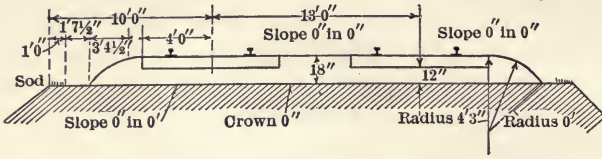

Tie, 6 in. by 8 in. by 8 ft.  
Baltimore and Ohio Railroad.

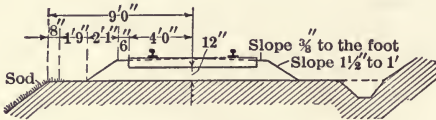

Tie, 6 in. by 8 in. by 8 ft.  
Chicago, Burlington & Quincy Railroad.

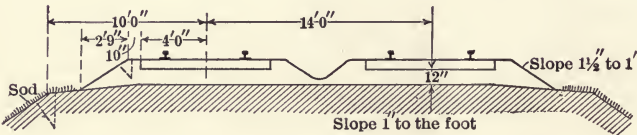

Tie, 6 in. by 8 in. by 8 ft.  
Illinois Central Railroad.

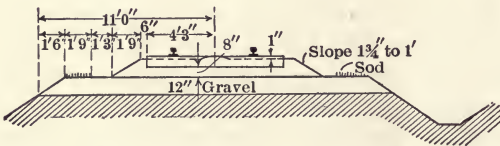

Tie, 7 in. by 9 in. by 8 ft. 6 in.  
Lake Shore & Michigan Southern Railroad.

Gravel.

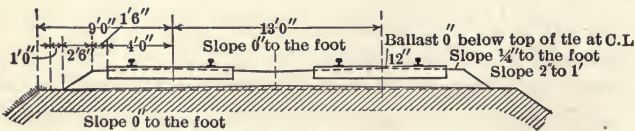

Tie, 6 in. by 8 in. by 8 ft.  
Grand Trunk Railroad.



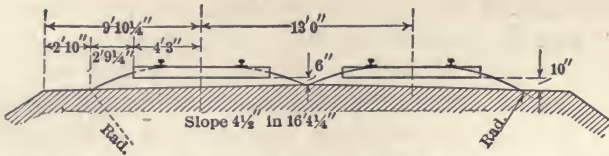

Tie, 7 in. by 9 in. by 8 ft. 4 in.  
 Pennsylvania Lines East.

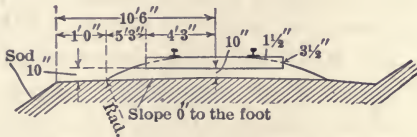

Tie, 7 in. by 9 in. by 8 ft. 6 in.  
 Pennsylvania Lines West.

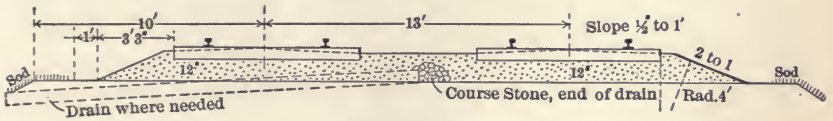

Crushed Rock and Slag  
 Class A

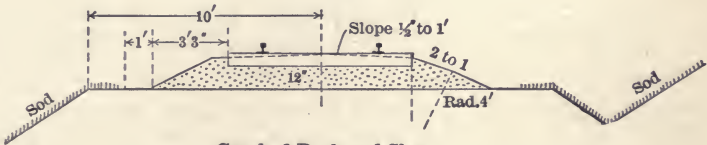

Crushed Rock and Slag  
 Class A

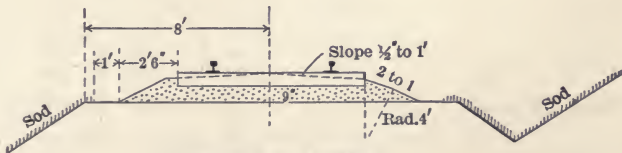

Crushed Rock and Slag  
 Class B

Figures Class A and B are the recommended A. R. E. A.  
 Sections under Varying Conditions.

Burnt clay is not used extensively. It pulverizes rapidly and the growth of weeds is heavy. It is usually a rather coarse material and should not be used except where cost of other ballast is high. Granulated slag ballast is molten slag run into water. It forms a fair ballast for yard and side-tracks. The coarse slag is practically crushed rock. It is hard, black and has very sharp projections, which cut into the ties, making renewals difficult, but is free from dust and weeds. Broken stone ballast can be worked the year around and is not easily displaced by running water and is practically dustless. It is expensive in first cost and makes tie renewals difficult.

The heavier the traffic the more economical stone ballast becomes, but it is not so for light traffic. On a comparatively solid subgrade a stone-ballasted track will remain in good condition longer than a gravel-ballasted track. Stone ballast, after being in use for some years, becomes filled with earth from the subgrade and with cinders and other foreign material, so that it does not properly drain off the water. It must be removed and cleaned with ballast forks or screens to remove the dirt and then replaced with 10 to 20 per cent of new material.

### Quantity of Ballast in the Standard Sections of Various Railroads.

TABLE 97. — STONE BALLAST SECTIONS.

Name of railroad.	Track.	Width at subgrade.	Crowning at center.	Depth of ballast under tie.	Cu. yds. per mile.
Chicago & N. W.....	Single	20' 0"	Curve	6"	2100
	Double	33' 0"	Curve	6"	4000
Chicago, Rock Island & Pacific.....	Single	18' 0"	Nil	8"	2100
	Double	33' 0"	.....	8"	4600
Pennsylvania Lines, West .....	Single	21' 4"	Nil	10"	2400
	Double	35' 4"	Nil	12"	6900
Lehigh Valley.....	Single	19' 0"	5"	7"	2500
	Double	32' 0"	5"	9"	5400
Pennsylvania Lines, East .....	Single	19' 8 $\frac{1}{2}$ "	2 $\frac{1}{2}$ "	8"	2600
	Double	32' 8 $\frac{1}{2}$ "	4 $\frac{1}{8}$ "	8"	5200
New York Central & Hudson River	Single	20' 0"	1 $\frac{1}{2}$ "	9 $\frac{1}{2}$ "	3000
	Double	33' 0"	2"	.....	7000
Baltimore & Ohio.....	Single	20' 0"	Nil	12"	3400
	Double	33' 0"	Nil	12"	7000
Illinois Central.....	Single	20' 0"	1" in 1' 0"	12"	3600
	Double	34' 0"	1" in 1' 0"	12"	7100
C. P. R.....	Single	17' 0" to 19'	$\frac{1}{2}$ " to 1' 0"	7"	2500
	Double	30' 0" to 32'	$\frac{1}{2}$ " to 1' 0"	7"	4800

TABLE 98. — GRAVEL BALLAST SECTIONS.

Name of railroad.	Track.	Width at subgrade.	Crowning at center.	Depth of ballast under tie.	Cu. yd. per mile.
Chicago & N. W.....	Single	20' 0"	Curve	12"	3000
	Double	33' 0"	.....	12"	6200
Chicago, Rock Island & Pacific....	Single	.....	.....	.....	.....
	Double	31' to 33'	Nil	6" to 8"	2800
Pennsylvania Lines, West.....	Single	21' 0"	Nil	10"	3600
	Double	36' 0"	Nil	12"	7000
Lehigh Valley.....	Single	18' 0"	5"	7"	2400
	Double	32' 0"	5"	7" to 9"	3500
Pennsylvania Lines, East.....	Single	19' 8½"	2½"	8"	2100
	Double	32' 8½"	4½"	8"	3700
New York Central & Hudson River	Single	20' 0"	1½"	9½"	3100
	Double	33' 0"	2"	9½"	6200
Baltimore & Ohio.....	Single	20' 0"	Nil	12"	3800
	Double	33' 0"	Nil	12"	7300
Illinois Central.....	Single	20' 0"	1" to 1'	12"	3800
	Double	34' 0"	1" to 1' 0"	12"	7100
C. P. R.....	Single	17' to 19'	½" to 1' 0"	7"	3000
	Double	30' to 32'	½" to 1' 0"	7"	5300

**Ballast Section Templates.**— In setting and trimming the ballast in maintenance work, a template made of wood is used by the section gang; arranged so that it is supported by the rails when set up in position, serving as a guide for the trimming and shaping of the ballast in accordance with the standard section.

The C. P. R. ballast templates are illustrated in Fig. 81a and are made of 1" × 4" and 1" × 6" timbers nailed together and shaped to conform with the lines of the ballast sections. It will be noted that both the main line and branch line templates for gravel ballast are alike except for position of gauge blocks.

The cost of each template is about \$1.50 each.

**Cost of Ballasting.**— Stone ballast is considered to be the most efficient; next comes broken slag (not granulated), then gravel, chatts, burnt clay or gumbo, and cinders. The efficiency of gravel ballast is much improved by washing, which removes clay and dust. Stone ballast that has been in the track for a long time gets clogged up with dust and dirt and is much improved by screening. Ballast is most economically handled by cars designed for the purpose but they are not always available; whatever class of car is used the cars in the train should be of

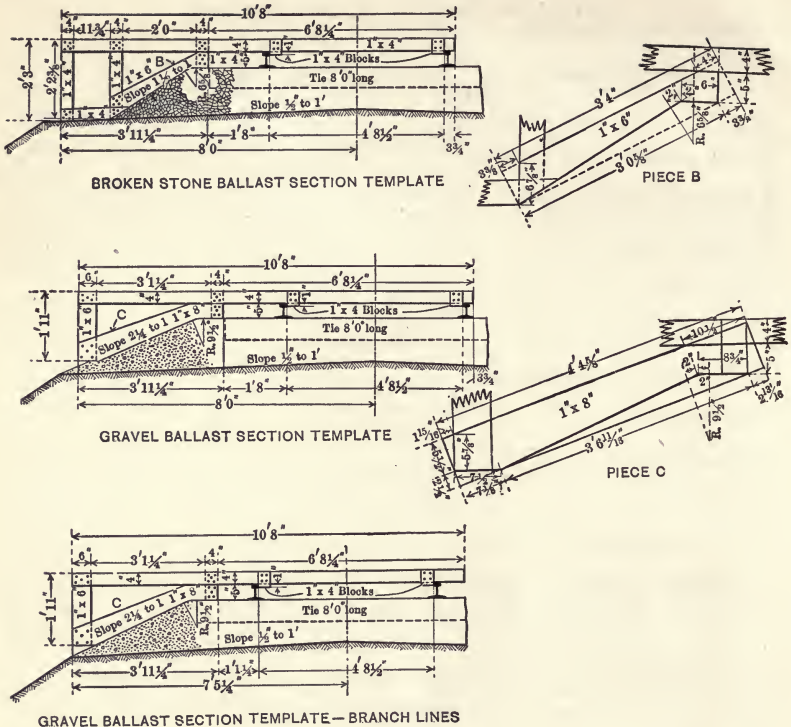

Fig. 81a.

uniform construction. On improvement work, when large quantities of ballast or waste material are to be handled, ballast car unloaders and spreaders are used.

The cost of ballasting will depend largely on local condition, the kind of ballast available or the kind and amount desired, the length of haul, density of traffic and the amount and class of work contemplated.

On the Missouri Pacific R. R. for train service in connection with ballasting done by contract the following daily charges were made for use of equipment (exclusive of labor and force):

Locomotive with cylinders to 18 in.....	\$10
Locomotive with cylinders 18-22 in.....	20
Shovels, steam, 40-60 ton.....	15
Shovels, steam, 60 ton and over.....	18
Cars derrick (incl. tool and blocking cars).....	20
Cars, wrecking, 30 ton.....	30
Cars, wrecking, 40-50 ton.....	40
Cars, wrecking, 78 ton and over.....	50

Contract prices for gravel ballasting for a 6-in. raise in track on the Missouri Pacific R. R.:

Loading and hauling from pit and unloading at point of application.....	52¢ per yard
Applying ballast.....	25¢ " "
Renewing ties (incl. necessary respacing ties and spikes furnished by company).....	15¢ " "

A carefully kept statement of the cost of ballasting with heavy gravel on a large single track division of a transcontinental road in 1913 gave the following:

TABLE 99. — COST OF BALLASTING TRACK WITH GRAVEL.

Cu. yd.	Average haul, miles.	Details of cost.													
		Loading.		Train service.		Unloading.		Putting under track.		Trimming.		Supervision.		Total.	
		Cost.	Per cu. yd.	Cost.	Per cu. yd.	Cost.	Per cu. yd.	Cost.	Per cu. yd.	Cost.	Per cu. yd.	Cost.	Per cu. yd.	Cost.	Per cu. yd.
36,321	31.0	\$763	2.1¢	\$4,721	13.0¢	\$600	1.9¢	\$11,000	30.2¢	\$3,000	8.2¢	.....	.....	\$20,084	55.4¢
32,445	39.4	1,121	3.4	3,256	10.3	1240	3.8	4,710	14.6	1,943	5.9	\$70	0.2¢	12,340	38.0
14,220	36.5	613	4.3	1,969	13.8	634	4.4	1,354	9.5	913	6.4	30	0.2	5,513	38.7
25,420	27.0	762	3.0	2,288	9.0	636	2.5	3,050	12.0	2,542	10.0	254	1.0	9,532	37.5
23,100	22.0	693	3.0	2,079	9.0	462	2.0	2,310	10.0	2,310	10.0	231	1.0	8,085	35.0
41,400	40.0	1,242	3.0	7,452	18.0	820	2.0	8,280	20.0	4,140	10.0	.....	.....	21,942	53.0
28,170	30.0	845	3.0	2,817	10.0	563	2.0	5,634	20.0	2,817	10.0	.....	.....	12,676	45.0
16,000	20.0	480	3.0	1,280	8.0	320	2.0	3,200	20.0	1,600	10.0	.....	.....	6,880	43.0
10,384	20.0	312	3.0	727	7.0	208	2.0	2,077	20.0	1,038	10.0	.....	.....	4,362	42.0
24,350	50.0	974	4.0	2,112	8.8	730	3.0	5,888	24.2	2,435	10.0	487	2.0	12,626	52.0
59,835	58.0	2,606	4.4	3,819	6.3	1400	2.3	7,161	12.0	2,871	4.3	219	0.4	17,776	29.7
32,945	16.0	1,318	4.0	1,977	6.0	659	2.0	2,636	8.0	659	2.0	.....	.....	7,240	22.0
18,655	40.0	1,676	9.0	1,280	6.9	350	2.0	3,015	16.0	1,536	8.0	310	1.9	8,167	43.8
363,245	36	13,405	3.7	35,777	9.8	8630	2.4	50,315	13.8	27,804	7.7	1601	0.8	147,232	40.6

Where item of supervision is omitted it has been included as labor under the various headings. Allow 5¢ for material and 4.4¢ for stripping, making 50¢ per cu. yd. for estimating.

APPROXIMATE COST OF GRAVEL BALLAST.

Average haul, 90 miles.	Cost per cubic yard.		
	Average, cents.	Minimum, cents.	Maximum, cents.
Loading.....	\$0.04	\$0.02	\$0.12
Train service.....	0.06	0.02	0.12
Unloading.....	0.01	0.01	0.03
Putting under track.....	0.12	0.08	0.20
Supervision.....	0.02	0.02	0.03
Total cost per cubic yard.....	\$0.25	\$0.15	\$0.50

## APPROXIMATE COST OF WASHED GRAVEL.

Washed gravel at pit.....	22-34.....	28
Washed gravel hauling.....	10-06.....	08
Washed gravel placed in track.....	25-35.....	30
Average.....		66 cents

The cost of placing ballast in track includes cutting out old ballast, dressing up new ballast and surfacing.

**Stone Ballast.**—Stone ballasting on maintenance work has been done by contract on a unit price basis per foot of track, the work principally consisting of the skeletoning out of the old ballast to the bottom of the ties, lifting the track to the grade stakes and surfacing, lining and trimming. Stone ballasting done by contract during season 1913 (about 12 miles double track) on the Michigan Central Ry., the unit prices for a stone ballast lift not to exceed 8 in. were as follows:

Skeletoning track.....	2.62¢ per ft.
Lifting track.....	3.50¢ “
Surfacing and trimming.....	5.54¢ “
Total.....	11.66¢ per ft. single track.

Unloading stone, putting in and spacing ties, and widening banks was done by the railway or on force account at actual cost; plowing down the ballast and distributing same and all train service incidental to such work is done with company's forces. When stone has to be moved more than 300 ft. by the contractor, an overhaul is allowed.

The company provided bunk cars for the contractor's men, including all tools and equipment needed in the work and free transportation for the men over its own lines. For ballast lifts exceeding 8 in., the contractor was allowed  $\frac{3}{4}$  cents per foot for each inch or fraction of an inch in excess of 8 in.

## AVERAGE COST OF STONE BALLAST.

Average haul, 60 miles.	Cost per cubic yard.		
	Average, cents.	Minimum, cents.	Maximum, cents.
Material.....	\$0.59	\$0.52	\$0.85
Train service.....	0.06	0.03	0.11
Unloading.....	0.01	0.01	0.03
Putting under track.....	0.28	0.18	0.38
Supervision.....	0.02	0.01	0.03
Total cost per cubic yard.....	0.96	0.75	1.40

**Cost of Reballasting with Broken Stone.**—Cost of reballasting with broken stone for various depths under the ties, figuring on removing the old ballast from shoulder and between ties to bottom of ties and giving the track a lift equal to the depth of stone proposed to be placed under the ties.

Usually stone is purchased by the ton f. o. b. cars; very few roads operate or own quarries.

For estimating purposes the weight of a cubic yard of solid granite may be taken at . . . . . 4500 lbs.  
 Voids when crushed ( $2\frac{1}{2}$  in. to  $\frac{3}{4}$  in.) . . . . . 40%  
 Weight of a cubic yard crushed granite will be  $4500 \times \frac{80}{100} =$  . . . . . 2700 lbs.  
 For crushed granite purchased at 48¢ a ton the cost per cubic yard will be  $48 \times \frac{2700}{2240} =$  . . . . . 65 cts.

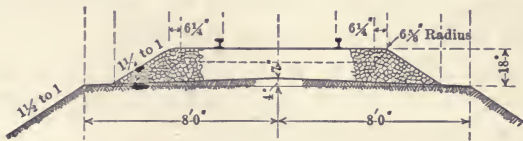

Single track.	5 in. under tie.	6 in. under tie.	7 in. under tie.	8 in. under tie.
	1800 cu. yds.	2100 cu. yds.	2500 cu. yds.	2900 cu. yds.
Cu. yd. crushed granite . . . . . 65¢	\$1170.00	\$1365.00	\$1625.00	\$1885.00
Train service ( $\frac{1}{4}$ ¢ per ton mile) . . . 15¢	364.50	424.50	505.50	586.50
Preparing track, 900 cu. yds. . . . . 20¢	180.00	180.00	180.00	180.00
Unloading ballast . . . . . 01¢	24.30	28.30	33.70	39.15
Putting under track and surfacing 25¢	450.00	525.00	625.00	725.00
Supervision and contingencies, abt. 10%	211.20	257.20	290.80	344.35
Cost per mile, single track . . . . .	\$2400.00	\$2780.00	\$3260.00	\$3760.00
Cost per foot, single track . . . . .	\$0.45 $\frac{1}{2}$	\$0.53	\$0.62	\$0.71
Cost per cu. yd., single track . . . . .	\$1.33	\$1.32	\$1.31	\$1.30

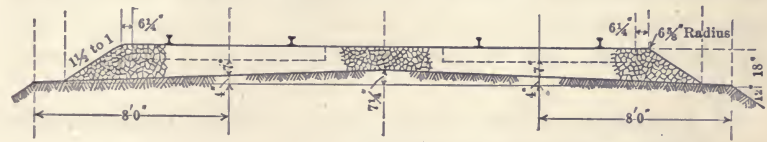

Double track.	5 in. under tie.	6 in. under tie.	7 in. under tie.	8 in. under tie.
	3400 cu. yds.	4100 cu. yds.	4800 cu. yds.	5500 cu. yds.
Cu. yd. crushed granite . . . . . 65¢	\$2210.00	\$2665.00	\$3120.00	\$3575.00
Train service ( $\frac{1}{4}$ ¢ per ton per mile). 15¢	688.50	829.50	972.00	1113.00
Preparing track, 2000 cu. yds. . . . . 20¢	400.00	400.00	400.00	400.00
Unloading ballast . . . . . 01¢	45.90	55.30	64.80	74.20
Putting under track and surfacing 25¢	850.00	1025.00	1200.00	1375.00
Supervision and contingencies, abt. 10%	405.60	495.20	573.20	662.80
Cost per mile, double track . . . . .	\$4600.00	\$5470.00	\$6330.00	\$7200.00
Cost per foot, double track . . . . .	\$0.87	\$1.04	\$1.20	\$1.38
Cost per cu. yd., double track . . . . .	\$1.35	\$1.34	\$1.33	\$1.32

For construction work when ballast pits have to be bought, also for spur tracks where the amount of ballast required is relatively small, it is usual to estimate 50 cents per cubic yard for gravel and \$1.25 per cubic yard for broken stone, for the work in place.

- On the Big Four stone ballast cost 60¢ cu. yd. f. o. b. cars.
- On the Big Four stone ballast cost 32¢ cu. yd. applying.
- On the Big Four gravel ballast cost 6¢ to 14¢ cu. yd.
- On the Big Four gravel ballast cost 12¢ cu. yd. applying.

The C. C. C. & St. L. Ry., St. Louis Div., put under stone ballast after stone was unloaded on the ground, at an average cost of 27 cents per track foot. This was an 8-in. average raise, and included tie renewals, dressing and filling.

W. I. French, Div. Eng., B. & O. Ry. (A. R. E. A., Vol. 15, No. 164), comments on the cost and the extras that may be entailed from lifting track as follows:

(a) Stone ballast costs from 45 to 80 cents per cubic yard, and to raise *one mile of double track* 10 in. will require 4380 cu. yd.; estimating this say at 60 cents per cubic yard, the cost of lifting track would be:

Material . . . . .	\$2628
Labor ballasting . . . . .	1300
Dressing after berm is raised . . . . .	300
· Total . . . . .	<u>\$4228</u>

(b) A 10-in. raise on a 10-ft. fill requires 2000 cu. yd. of filling per mile to restore standard embankment at, say, 50 cents per cubic yard, and will amount to \$1000. The raising in cuts fills the ditches, and requires widening the cuts, which is very costly.

(c) The lift may also require raising bridges, platforms and depots and lengthening culverts, etc.

### Cost of Cleaning Ballast.

The following table from the A. R. E. A. proceedings (Vol. 15) shows a comparison of cost of cleaning ballast on several roads and by different methods. It will be seen that the costs vary widely, due to the various methods employed and the various depths to which ballast was cleaned.



Tests on the Baltimore & Ohio show that ballast can be cleaned by use of screens for just one-half the cost of doing the work with forks, and the results are said to be more uniform and altogether more satisfactory:

Railroad.	Method of cleaning.	Cost per mile, double track.	Remarks.
Pennsylvania..... (Eastern Div.)	Forks. (Screened dirt.)	\$1074.60	Space between ties cleaned to bottom of ties. The shoulders outside the track and space between tracks to a depth of 12 in. below base of ties. Ten yds. of stone reclaimed by screening from dirt obtained by forking one-half mile double track at cost of \$159.
Pennsylvania..... (Pittsburg Div.)	Forks. (Screened dirt.)	\$2252.00	Section cleaned same as above. Seventy-five yds. of stone reclaimed by screening from dirt obtained by forking one-half mile of double track at cost of \$165.
N. Y. N. H. & H.....	Forks.	\$2500.00 (Four tracks.)	
C. R. R. of N. J.....	Forks.	\$1484.00 to \$2534.40 \$3115.20 (Four tracks.)	Estimated that from 150 to 300 yds. of ballast are lost per mile of track, when cleaned at intervals of three years.
N. Y. C. & H. R.....	Forks.	\$491.04 (Single track.) Under and between ties to a depth of 6 in.	Material removed consists largely of dirt; averages about 30 per cent.
		\$813.12 (Single track.) In space between ties, track 12 ft.	On four-track territory. Waste divided as follows: 16 per cent of stone could not pass through 1-in. mesh, 24 per cent stone passed through 1-in. mesh, but was retained on $\frac{3}{4}$ -in. mesh; 60 per cent dirt passed through $\frac{3}{4}$ -in. mesh.
B. & O.....	Screens.	\$622.00	Cleaning and dressing. Cleaned to 12 in. below bottom of tie at berm. Cleaned to bottom of tie between ties. Cleaned to 6 in. below bottom of tie in center ditch.
		\$576.00	Cleaning only. Same depth.
		\$262.00	Cleaning center ditch and berm only.
		\$363.00	Cleaning 6 in. below tie in center ditch and to bottom of tie between ties on each adjacent track.
		\$145.00	Cleaning ditch only.

## CHAPTER XII.

## TRACKLAYING AND SURFACING.

**Tracklaying.** — There are numerous methods of laying track depending upon the kind of work entailed, whether it is for a new line, a second track, or re-laying.

Tracklaying on a new line will entail a material yard to store the ties, rails, fastenings, turnouts, etc., located to suit the local conditions, the method of tracklaying proposed, the amount of work involved, etc., and as the material has to be forwarded over the track under construction the arrangement should be such that will best suit the gang organization, the latter being dependent on the weight of steel, kind of construction and method of trackwork proposed, whether by hand or a combination of gang and machines.

The cost of tracklaying is very variable depending upon a large number of factors and conditions, and whether new steel or old steel is being laid. Exclusive of ballast and ballasting, the cost of tracklaying only, varies from \$200 to \$300 per mile.

Tracklaying for second track is generally less costly than for a new line, as the material can be distributed from the old track to better advantage; it may average \$150 to \$250 per mile.

**Tracklaying and Surfacing.** — In addition to the tracklaying, this includes picking up low joints, tamping ties and redressing ballast. The cost varies from \$350 to \$650 per mile.

**Loading and Unloading Rail.** — An economical method of handling rails is to have them shipped workways on flat cars with boards between each layer, unloading with rail unloaders.

The rail unloaded where the machine can work freely will handle a rail per minute provided it is not held up waiting for the men to release rails. For quick work in storage yards a locomotive crane with a magnet can be used. To expedite the unloading of rail along the track, rail has been transferred from coal cars to flat cars with a rail loader in a yard at a cost of \$2.10 per car.

Unloading new rail with rail loader costs . . . . .	\$25 to \$35 per mile.
Loading up old rail with rail loader costs . . . . .	\$25 to \$35 " "

**Relaying Rail.** — The relaying of rail is one of the big items of maintenance work usually undertaken during the summer; a rail laying gang cost approximately \$150 per day, or \$15 per hour. When a rail laying machine is used, the number of men in the rail-laying portion of the gang may be reduced accordingly.

The rail laying gang is usually closely followed by the surfacing gang, to readjust the ties at the new joints and to surface the track in finished condition. Rail taken up out of the track should be classified before being picked up.

In relaying rail it is usual to distribute the new rails outside of the track and to relay one line of rails at a time.

There are two methods in vogue for handling work of this kind, — either the old rails are shifted outwards and the new rails lifted over them and set in place, or the old rails are moved inward and then disconnected and thrown out after the new rails have been placed. On double track the rail laying should proceed in direction of the traffic.

The cost of relaying rail will depend on the amount of track work done when the new rail is being placed. On one of the New York Central lines it cost 4 cents per track foot to lay rail under heavy traffic, unloading new rail and picking up old rail not included. This is about \$211 per mile and adding \$60 as the cost of unloading new rail and picking up old rail, it would total \$271 per mile, single track.

The C. C. C. & St. L. Ry. gives the cost of taking up 80-lb. rail and laying 90-lb. rail per mile, single track, as follows:

Unloading new rail, with rail loader.....	\$27
Loading up old rail.....	27
Laying new rail.....	135
Total per mile.....	\$189

An ordinary estimate for this class of work where a certain proportion of new ties, surfacing and other work has to be done, gives the cost at \$550 per mile as follows:

Taking up old rail, per mile.....	\$25
Unloading new rail, per mile.....	25
Adzing ties per mile.....	9
Respacing ties, @ 3¢ per foot.....	158
Resurfacing, @ 3¢ per foot.....	158
Laying new rail, @ 1½¢ per foot.....	79
Putting new ties, 5 per cent, 150 @ 65¢.....	96
Total per mile.....	\$550

On the L. Valley, in June, 1915, one work train with several machines loaded 149,466 lin. ft. of 90-lb. rail, with fastenings or 14.15 track miles, on the Seneca Division, in one day. This comprised 2002 tons of rails and was loaded at a cost of 15.6 cents per ton, or about \$22 per mile.

**Throwing Track.** — Men will ordinarily be distributed at about 2-ft. intervals. A 2-ft. section of track weighs about 182 lb., while the resistance against throwing laterally is ten times this amount or 1820 lb. The average man can lift his own weight or 142 lb.; with a lining bar he can lift four times his own weight or 568 lb.

**Tie Tamping.** — The pneumatic or mechanical tamping machine mounted on a push car, having a compressor and gasoline engine, equipped with tampers driven by compressed air, requiring a man to operate each tamper and also a man to work the machine, has been in experimental use for some time on a number of roads and while no definite recommendation is given as to the economy to be obtained as against hand tamping, the results are much better than hand tamping, are more uniform and track stays up better; and in situations where it is desirable to have the least disturbance of track, such as crossings, turnouts, tunnels, river tubes, etc., the results will be very satisfactory. Electric tampers are also used.

**Cost of Tamping.**

D. L. & W. Ry.

2 cents per tie for mechanical tamping.

1.8 cents per tie for hand tamping.

N. Y. N. H. & H. Ry.

5.17 cents per tie for mechanical tamping, 3.92 to 9.30 cents.

6.51 cents per tie for hand tamping, 4.44 to 10.09 cents.

Expect to reduce cost by mechanical tamping to 4 cents per tie.

Erie Ry., stone ballast:

3.6 cents per tie for mechanical tamping.

3.4 cents per tie for hand tamping.

**Renewing Ties.** — Renewing ties in main track "in face" consists of digging the ballast from around the old tie, drawing the spikes, removing the old tie, preparing the new bed, carrying new tie from pile, placing new tie in position, spiking it to gauge and tamping it solidly in position, after which the ballast, having been cleaned, is returned to the crib and the shoulder redressed and the old tie removed for burning.

The renewing of eight ties per ten hours in stone ballast is considered a good average performance for one gang.

**Respacing Bunched Ties** consists of digging out the ballast from between the ties, drawing spikes, driving tie in place, spiking to gauge, tamping, cleaning the ballast and redressing the shoulder. Respacing twelve ties in ten hours is considered a good average performance for one gang.

**Tie Plugs.** — As ties fail quite as much from spike cutting as from rail cutting, tie plugs play quite an important part in the life of the tie, especially where the curvature is heavy, and it is necessary to reline and regauge track at frequent intervals. Because of the wave motion in a passing train there are comparatively few spikes that have their head in contact with the rail, the tendency being for the spike to work upwards, and it is necessary to have them redriven from time to time, until it eventually becomes necessary to redraw them and drive them in a new

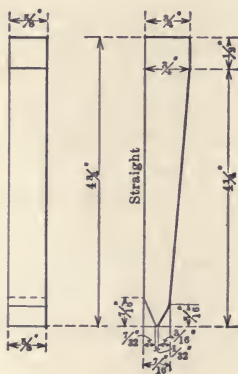

Fig. 81b.

place. It is false economy to redrive a spike without immediately plugging the hole it formerly occupied.

**Cost of Tie Plugs.** — The type of tie plug used for this purpose by the C. P. R. is shown, Fig. 81b. The cost is about 75 cents per thousand untreated or \$1.10 per thousand treated; the timber used is local hardwood.

All plugs must conform strictly to outlines and dimensions shown and be of full size and length.

They must be made from sound, thoroughly air-dried white pine, free from knots and sap.

A small percentage of hardwood plugs may be ordered and shall be of white oak, rock elm, birch or maple.

Bags or boxes to be used for shipping.

Plugs are purchased subject to inspection and acceptance of the railway company's inspectors.

**Cutting and Destroying Weeds.** — Usually the weeds are cut with a shovel and thrown on the sides of the piles. The cost is about \$25 per mile per year. On dirt track this practice from between ties and from heads of ties leaves the track in a bad condition and necessitates the section forces refilling same.

**Weeding Track.** — To replace hand weeding of track, weed burners have been used to a limited extent, and weed destroyers by the use of chemicals.

The application is made in a dry spell with a tank car and sprinkling device to distribute over the track. Average cost \$35 to \$45 per mile.

Chicago, Milwaukee & St. Paul Ry. treated sixteen miles in 1911 with an average of 62.5 gals. per mile at a cost, including expense of train crew, of \$26.25 per mile.

Baltimore & Ohio Ry. treated thirty-six miles in 1912, a width of 12 ft. with 100 gals. per mile at a cost of \$37.75 per mile, exclusive of \$29.35 for equipping car with a sprinkling device.

**Temperature Expansion (A. R. E. A.).** — When laying rails their temperature should be taken by applying a thermometer. To allow for expansion the openings between the ends of adjacent 33-ft. rails should be as follows:

Temperature, Fahrenheit.	Allowance.
-20° to 0° .....	$\frac{5}{16}$ inch
0° " 25° .....	$\frac{1}{4}$ "
50° " 75° .....	$\frac{3}{16}$ "
75° " 100° .....	$\frac{1}{8}$ "
Over 100° rails should be laid close, without bumping .	$\frac{1}{16}$ "

**Tile Drains.** — When cut and surface drainage is insufficient to carry off the surface water, or where trouble has developed from the formation of water pockets, or where the material holds the water so that it is prevented from escaping, or where conditions are such that the track is rendered soft and spongy during rainy spells, making it hard to maintain proper line and surface, such trouble is very often remedied by the introduction of tile drains. Drainage of this character is very common and each road has its own methods of getting results.

A method of draining wet cuts on the eastern lines of the A. T. & S. F. Ry. is shown on Fig. 82. The side of the cut is ditched as shown and the tile laid at the bottom, connecting with which are branch drains at about  $16\frac{1}{2}$  ft. centers, staggered; with the Santa Fé section, the ditch is about 3 ft. deep, 1 ft. wide at the bottom and 7 ft. at the top. The branch pipes are laid so as to tap the bottom of the ballast or cinder pocket and the lateral trench is usually filled with ballast and the main ditch with cinders.

The cost of such work will vary; 25 to 30 cents per lineal foot is a common figure for estimating 6-in. and 4-in. tile drainage for track work.

**French or Rock Drains.** — For draining an embankment the "French" or rock drains are used to a large extent on the Santa Fé. These are simply trenches filled with broken stone, 3 to 4 ft. wide, ordinarily at right angles to the track and extending to a depth sufficient to drain the water pocket.

Some cases extend entirely through and in other cases only from about the center to one face of the embankment. The bottom of the trench is graded sufficient to ensure flow and the distance they are spaced apart, etc., depends upon the location and character of the pocket to be drained. The rock is usually rip-rap or one man stone, and sometimes a longitudinal drain at the foot of the embankment is also inserted into which the blind drains are connected.

The cost of rip-rap stone is usually figured at about \$1.25 per cubic yard in place; where rock is available the cost may be as low as 50 cents per cubic yard in place.

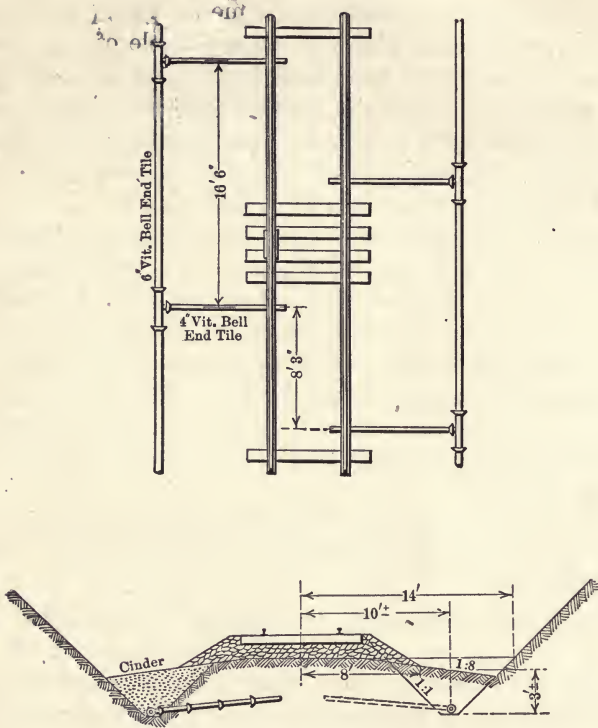

Fig. 82. Details of Tile Drain.

### Surface and Sub-surface Drainage (A. R. E. A.). —

1. Water should be kept off the roadbed if possible.
2. Intercepting ditches should be constructed for the protection of cuts.
3. Intercepting ditches or pipe drains should be provided for the protection of banks built on saturated soils.
4. Side ditches should be constructed in cuts through all classes of materials.
5. Pipe drains should be provided for the drainage of wet cuts.



## EQUATING TRACK VALUES.

To determine how the proper standard of maintenance may best be obtained and at the same time assign equal or equivalent duties to all trackmen the following table of equated track values has been suggested by the Roadmasters and Maintenance of Way Association.

EQUATED TRACK VALUES FOR PRACTICAL APPLICATION.

Class.	Force, one foreman and	Equiv. mileage or sect.	Men per mile with foreman.	Men per mile without foreman.	Miles per man with foreman.	Miles per man without foreman.	
A. Double track lines	S.....	6 men	9	0.78	0.67	1.29	1.50
	W.....			0.44	0.33	2.25	3.00
A. Single track lines	S.....	4 men	6	0.83	0.66	1.20	1.50
	W.....			0.66	0.50	1.50	2.00
B. Single track lines	S.....	4 men	7	0.71	0.57	1.40	1.75
	W.....			0.57	0.43	1.75	2.33
C. Single track lines	S.....	3 men	8	0.50	0.37	2.00	2.67
	W.....			0.37	0.25	2.67	4.00

Each supervisor should have a permanent extra gang on his district on the following percentage of the actual main line and siding mileage (not equated):

Class A. Summer, 10 per cent; winter, 5 per cent.

Classes B and C. Summer, 6 per cent; winter, 3 per cent.

## Proposed Equated Track Mileage Value.

2 miles of passing track equal 1 mile of main track.

2½ miles all other sidings equal 1 mile of main track.

15 switches equal 1 mile of main track.

24 single derails connected with tower or switch stands equal 1 mile of main track.

12 single track railway crossings equal 1 mile of main track.

15 single highway crossings (public roads) equal 1 mile of main track.

10 single highway crossings (city streets) equal 1 mile of main track.

## Classification Track.

Class A railways are those having more than one track, or a single track with the following traffic per mile:

Freight cars per year equal 150,000 or 5,000,000 tons.

Passenger cars per year equal 10,000.

Maximum passenger speed of 50 miles per hour.

Class *B* roads are those single track lines having the following traffic per mile:

Freight cars per year equal 50,000 or 1,670,000 tons.

Passenger cars per year equal 5000.

Maximum passenger speed of 40 miles per hour.

Class *C* lines are single track lines not meeting the minimum requirements of Class *B*.

### TOOL EQUIPMENT.

Tools to supply every man in the gang and several extra for repair purposes are required, for each section.

The kind of tools used vary according to the ballast and other conditions, and the following is an average list of the minimum equipment for section gang of foreman and three men:

Adzes.....	2	Handles, pick.....	2
Axes.....	1	Jack track.....	1
Bars, claw.....	2	Lanterns.....	4
Bars, crow.....	2	Levels, spirit pocket.....	1
Bars, lining.....	2	Levels, track.....	1
Bars, tamping.....	2	Oil can.....	1
Boards, elevation.....	1	Oiler.....	1
Brooms.....	1	Oil (signal), pints.....	4
Cars, hand or motor.....	1	Padlock, key, and chain.....	2
Cars, push.....	1	Pail, water.....	1
Chisel rail.....	5	Picks and handles.....	4
Cup, tin.....	1	Platform dumping for push cars.....	1
Flags, red.....	2	Ratches and 3 drills.....	1
Flags, yellow.....	2	Rail tongs.....	2
Grindstone.....	1	Saws, hand.....	1
Gauge, track.....	1	Saws, crosscut.....	1
Globes, red.....	2	Scythe, complete, grass or brush.....	1
Globes, white.....	2	Shovels, track.....	6
Globes, yellow.....	2	Switch key.....	1
Hammers, maul.....	2	Tape, 50 feet.....	1
Hammers, nail.....	1	Template, standard roadbed.....	1
Hammers, sledge.....	1	Torpedoes.....	12
Handles, adze.....	1	Wrenches, monkey.....	1
Handles, axe.....	1	Wrenches, track.....	3
Handles, maul.....	2		

#### *Approximate cost.*

1 car, hand.....	\$40
1 car, push.....	30
1 car, dump platform.....	21
1 rail bender.....	27
1 rail drill.....	25
Balance as per list.....	182
Total.....	\$325
If motor car instead of hand car add.....	175
	<u>\$500</u>

**Equipment for One Extra Gang.** — 1 eccentric rail bender, 1 rail drill, 8 1-in. and 4 1½-in. bits, 4 15-ton double action track jacks, 6 hand or motor cars, 4 push cars, 4 platform dump boxes, 6 dozen snow shovels, 6 track wrenches, 6 claw bars, 12 spike mauls, 24 lining bars, 12 rail tongs, 24 cold sets, 6 dozen track shovels, 24 spike maul handles, 24 pick axes and handles, 12 adzes and handles, 1 50-ft. tape complete, 1 crosscut saw, 1 hand saw, 1 1-in. auger 12 in. long, 6 tamping bars, 1 16-in. monkey wrench. 1 12-lb. sledge hammer.

*Approximate cost, \$650 to \$1500.*

STANDARD SIZES OF TOOL HOUSES ON VARIOUS RAILROADS.

Pennsylvania.....	16 ft. by 30 ft.	Philadelphia and	
Pennsylvania.....	16 ft. by 20 ft.	Reading.....	10 ft. by 13 ft.
Pennsylvania.....	12 ft. by 14 ft.	Canadian Pacific and	
Cincinnati Southern.	12 ft. by 16 ft.	Northern Pacific..	10 ft. by 24 ft.*
Union Pacific.....	10 ft. by 14 ft.	Canadian Pacific and	
Atchison, Topeka &		Northern Pacific..	10 ft. by 12 ft.†
Santa Fé.....	12 ft. by 16 ft.	Lehigh Valley.....	16 ft. by 20 ft.

**Motor and Hand Cars.** — The adoption of motor cars instead of hand cars is generally recommended; by using motor there is said to be a saving of two cents per mile over the hand car. In many cases engines are purchased and mounted on the hand car.

Price of one hand car.....	\$25.00
Price of one motor car.....	200.00
Price of one engine attached to hand car.....	130.00

On sections employing up to eight men, a motor car may affect a saving of one man.

The idea of the motor car instead of the hand car is to save time and energy; to relieve the men from the extra labor of hand car pumping and to enable gangs to combine and respond for emergency work without loss of time.

The Baltimore & Ohio figures that a saving amounting to \$101.42 per year is necessary to make it economical to substitute a motor car costing \$200 for a hand car whose first cost is \$25. The comparative capitalized cost of the two is estimated as follows:

\* Double.

† Single.

	Motor cars.	Hand cars.
First cost of cars.....	\$200.00	\$25.00
Life of cars.....	6 yr.	5 yr.
Interest on first cost of 5 per cent.....	10.00	1.25
Annuity for depreciation at 5 per cent.....	20.94	4.52
<i>Operation:</i>		
Gasoline at \$0.15.....	\$49.35	
Oil at \$0.50.....	9.50	
Batteries at \$0.20.....	8.40	
Repairs.....	12.00	
Total.....	\$79.25	3.00
Annual cost.....	\$110.19	\$ 8.77
	8.77	
Cost of operation.....	\$101.42	

**Cost of Operation.** — For bridge gangs, motor cars save much time which would otherwise be wasted in waiting for local freights to move the gang from one job to another. Several roads also mention the saving in train service which is effected by distributing bridge material on motor cars.

Analysis of costs of operation which have been obtained by B. & B. Assoc., 1913, show the following:

AVERAGE COSTS PER 100 MILES.

	Fuel.	Repairs.	Total.
Section.....	1.10	1.04	2.14
Bridge.....	1.20	1.60	2.80
Maintainers.....	0.45	.....	.....
Inspection.....	1.07	0.91	1.98
Miscellaneous.....	1.16	.....	.....

The cost per 100 miles is larger for bridge men, which is consistent with the larger size of bridge gangs.

The value of the time saved in one month during 1912 averaged \$71.33 for 3 section gangs, and was \$286.08 for one extra gang. To enable comparisons to be made, one road is now reducing the data on cost of operation of motor cars to a ton-mile basis.

**Type of Car.** — Small engines have been installed on hand cars and found satisfactory for section gangs, especially for gangs of two or three men, on account of their lighter weight. The more rigidly constructed motor cars are better adapted to the use of the larger bridge gangs.

The advantage of the 2-cycle engine is its simplicity of operation, while the manufacturers of the 4-cycle engine claim greater economy in oil. Other features to be considered in choosing a car are: method of cooling, air or water, depending on whether car is to be used for running continuously for long distances, or intermittently; type of drive, direct or friction, and power required.

**Recommended Requirements of Motor Cars.**—The car should be as light as possible consistent with required strength, and should not weigh more than 1000 lbs. The most of the weight should be over the loose wheels, to facilitate taking the car off the track. Small pipes, which freeze quickly, should not be used for cooling. Water cooling should not be added if necessitating very much additional weight.

The car should be designed to run either way at the same speed, with equal safety. The motor should be started with the car at rest, and car started by a clutch or belt.

The maximum speed possible should not exceed 20 miles per hour. It is very desirable to have at least two speeds in either direction to enable the car to pull heavy loads up steep grades at low speed, and at increased speed over light grades.

The car should be designed as simply as possible, with all parts easily accessible.

#### SECTION FORCE TRACK WORK.

There is a great deal to be said in favor of a definite program of section force work, and whether it is followed out or not in actual practice, it is bound to help the section foreman as it brings to his attention many items that might otherwise be neglected.

A suggested plan of work by W. F. Rensch, described in the August number of the *Ry. Main. Engineer* for 1916, is given below. It is recognized of course that certain conditions must exist before a program of this kind can be carried out, and when such are lacking it would have to be modified to suit seasonable and other conditions.

In the item of rail renewal there is a possibility of divergence because the material may not be supplied promptly. A large percentage of the rail is scheduled to be applied in the winter and early spring; this is rendered practicable by the increas-

Month.	Per cent of ties to be renewed in main tracks at end of month.		Progress.		Per cent of rail renewals to be completed at end of month.	Progress.		Work to be engaged in.
January.....					15			Laying new rail, constructing standard ditches, removing snow and ice, surfacing, shimming and gaging.
February.....					30			Laying new rail, constructing standard ditches, removing snow and ice.
March.....					45			Mainly surfacing, continuing rail renewals, starting tie renewals, policing the road, installing under drainage.
April.....	27		25		50			First half, laying rail, putting in ties, raising track where tie renewals were made; second half, surfacing track.
May.....	46		35		65			Vigorous prosecution of tie renewals, rail renewals and track raising, with as much policing as possible.
June.....	57		50		70			First three weeks, surfacing, including track raising; last week, continuing rail and tie renewals. Mow the right of way about the middle of the month.
July.....	72		68		85			First half, continuing rail and tie renewals; second half, lining and surfacing and gaging.
August.....	90		78		90			Vigorous prosecution of tie renewals, track raising, rail repairs, with as ample policing as possible.
September....	95		90		95			First half, surfacing and lining; second half, general policing of roadway, ballast border and ditches, with rail and tie renewals in sidings. Mow the right of way the second week in this month.
October.....	100		100		100			Final policing of the road for the division inspection along with necessary lining, surfacing and gaging and repairing crossings.
November.....								Surfacing and lining in order to enter upon the closed period in the best shape possible.
December.....								Cleaning snow and ice, keeping ditches open, making standard ditches where possible.

Saturday to be devoted to policing, cleaning up scrap, pulling grass and weeds.

Between June and September, two days each month to be devoted to tightening bolts.

Last working day each month, bridge seats to be cleaned thoroughly.

When making tie renewals, 3½ days to be devoted to putting in ties, 1½ days to surfacing or raising the stretch renewed.

ing use of plain base splices and the ability to postpone for a time the spacing of the ties. The program coördinates the laying of rail to some extent with the several periods.

CHAPTER XIII.

RIGHT OF WAY FENCES.

**Wire Fence.** — The wiring is generally purchased in accordance with the company's specification. Particular attention should be given to the gauge of wires, the galvanizing and the weaving.

Either woven or field erected fencing is used. When woven, the fence is shipped in rolls, and when field erected, the wire is usually sent from the shop in reels.

The C. P. R. standard fences are shown, Fig. 82a, both for woven and field erected. The woven fence is used on fairly even ground and the field erected when the ground is rough and uneven.

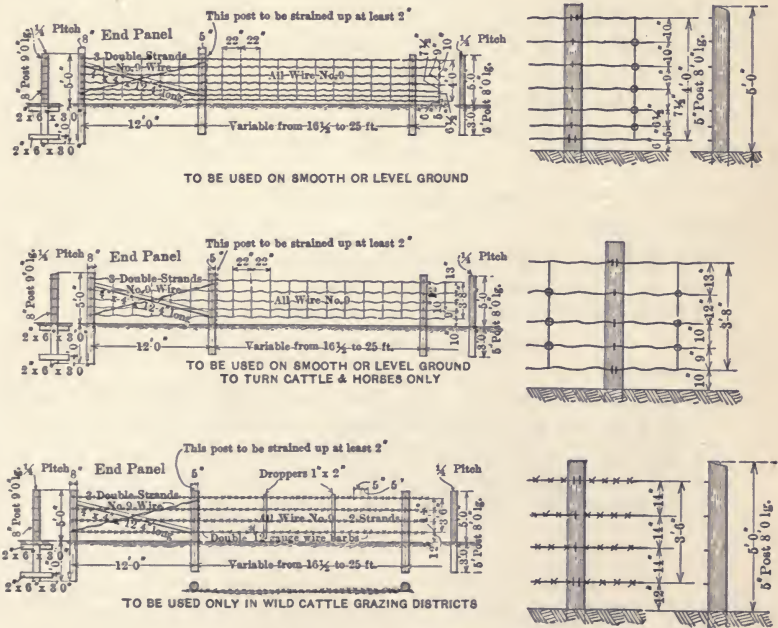

Fig. 82a. C. P. R. Fences.

TABLE 100. — APPROXIMATE COST, GALVANIZED IRON FENCES.

Material per rod (16½ ft.).	7-strand woven wire.	7-strand field erected.	5-strand woven wire.	5-strand field erected.
Wire fencing F.O.B. (gal. iron).....	0.30	0.37	0.25	0.31
Posts (wood).....	0.18	0.18	0.18	0.18
Staples, locks, etc.....	0.05	0.07	0.04	0.06
Erection.....	0.18	0.27	0.16	0.24
Supervision and contingencies.....	0.09	0.16	0.07	0.11
Cost per rod.....	\$0.80	\$1.05	\$0.70	\$0.90
Cost per mile fence.....	\$256.00	\$336.00	\$224.00	\$288.00
Cost per mile track.....	\$512.00	\$672.00	\$448.00	\$576.00

## BILL OF MATERIAL FOR ONE MILE.

## WOVEN SEVEN-WIRE FENCE.

*Posts 25 ft. apart:*

- 320 rods 7-wire 48-in. woven wire fencing as specified.
- 14 lb. 1½-in. galvanized wire fence staples.
- 212 fence posts 8 ft. 0 in. long, 5-in. diameter at small end.

*For end panel add:*

- 1 fence post 9 ft. 0 in. long, 8 in. diameter at small end.
- 1 piece 4 in. × 4 in. × 12 ft. 4 in. long.
- 2 pieces 2 in. × 6 in. × 3 ft. 0 in. long.
- 1 lb. 60 d. steel wire nails.
- 30 yds. wire No. 9.

## WOVEN FIVE-WIRE FENCE.

*Posts 25 ft. apart:*

- 320 rods 5-wire 44-in. woven wire fencing as specified.
- 11 lb. 1½-in. galvanized wire fence staples.
- 212 fence posts 8 ft. 0 in. long, 5 in. diameter at small end.

*For end panel add:*

- 1 fence post 9 ft. 0 in. long, 8 in. diameter at small end.
- 1 piece 4 in. × 4 in. × 12 ft. 4 in. long.
- 2 pieces 2 in. × 6 in. × 3 ft. 0 in. long.
- 1 lb. 60 d. steel wire nails.
- 30 yds. wire No. 9.



BILL OF MATERIAL FOR ONE MILE (*Continued*).

## FIELD ERECTED SEVEN-WIRE FENCE.

*Posts 25 ft. apart:*

- 14 reels of 160 lbs. each of wire as specified.
- 14 lb. 1½-in. galvanized wire fence staples.
- 212 fence posts 8 ft. 0 in. long, 5 in. diameter at small end.

*For each panel add:*

- 1 fence post 9 ft. 0 in. long, 8 in. diameter at small end.
- 1 piece 4 in. × 4 in. × 12 ft. 4 in. long.
- 2 pieces 2 in. × 6 in. × 3 ft. 0 in. long.
- 1 lb. 60 d. steel wire nails.
- 30 yds. wire No. 9.
- 27¼ bundles of stays of 100 each as specified.
- 14,240 locks as specified.

## FIELD ERECTED FIVE-WIRE FENCE.

*Posts 25 ft. apart:*

- 10 reels of 160 lbs. each of wire as specified.
- 11 lbs. 1½-in. galvanized wire fence staples.
- 212 fence posts 8 ft. 0 in. long, 5 in. diameter at small end.

*For end panel add:*

- 1 fence post 9 ft. 0 in. long, 8 in. diameter at small end.
- 1 piece 4 in. × 4 in. × 12 ft. 4 in. long.
- 2 pieces 2 in. × 6 in. × 3 ft. 0 in. long.
- 1 lb. 60 d. steel wire nails.
- 30 yds. wire No. 9.
- 27¼ bundles of 100 each of stays as specified.
- 8480 locks as specified.

## STOCK RANGE FENCE.

- 27 reels of 100 lbs. each of barb wire as specified.

*When posts are 25 ft. apart:*

- 22 lb. 1-in. galvanized wire fence staples.
- 9 lb. 1½-in. galvanized wire fence staples.
- 636 1-in. × 2-in. droppers 4 ft. 6 in. long.
- 212 fence posts 8 ft. 0 in. long, 5 in. diameter at small end.

*For each end panel add:*

- 1 fence post 9 ft. 0 in. long, 8 in. diameter at small end.
- 1 piece 4 in. × 4 in. × 12 ft. 4 in. long, 2 pieces 2 in. × 6 in. × 3 ft. 0 in. long.
- 30 yds. wire No. 9. 1 lb. 60 d. steel wire nails.

COMPARATIVE COSTS OF FENCING WITH METAL POSTS AND WOOD POSTS  
ON THE B. & O. R. R.

On two sections of test fence, 4620 ft. long each, on the Philadelphia Division of the B. & O. R. R., erected in May, 1913, one section had metal posts and the other had wood posts; the cost was as follows:

Material.	Steel posts.	Wooden posts.
Labor, driving and tamping intermediate....	\$0.0573	.....
Setting end or anchor posts.....	1.22	.....
	<b>\$1.2773</b>	.....
Digging holes, distributing and setting.....	.....	\$0.1879
Erecting fence on posts per rod.....	0.18	0.1576
Erecting fence on posts per mile.....	57.60	50.43
Stretching wire, per rod.....	0.0613	0.0672
Stretching wire, per mile.....	19.62	21.50
Posts, price.....	0.245 (line)	0.18
Posts, cost in place.....	0.3023	0.2679

**Concrete Fence Posts.** — Concrete fence posts have been used extensively on the Chicago, Burlington & Quincy. The standard post is of circular section,  $3\frac{1}{2}$ -in. top,  $4\frac{1}{2}$  in. at the butt and 7 ft. long reinforced with six wires; thirteen pin holes are provided to permit of the application of the fence wires.

The material necessary to make 100 posts are 19 sacks of cement,  $2\frac{1}{4}$  cu. yd. washed sand and 100 sets of six wire reinforcement 7 ft. long.

Posts are said to cost 21 cents each in the storage pile when made by the railroad.

**Old Boiler Flue Fence Posts.** — Old boiler flues are used to some extent on the Chicago, Rock Island & Pacific for fence posts. The flues are cut in 7-ft. lengths, and the holes are machine punched in one operation for the wire fence to be used. After the posts are pointed at one end they are dipped in hot asphalt and then dried. The cost allowing scrap value for old flues is between 7 and 10 cents or an average of  $8\frac{1}{2}$  cents per post. The flues are driven into the ground by means of a maul, the top being protected by a board while driving.

For permanent and portable snow fences see page 275.

**Farm Crossing Gates.** — Generally made of wood and wire, or gas pipe and wire, the last mentioned being known as the steel gate.

Usually 14 and 16 ft. long, standing 4 ft. 6 in. above ground 4 ft. high, made to swing outward away from track.

Kind.	Approximate cost, delivered F. O. B.
Swing wire gate with wooden frame complete 14 ft. long (Fig. 84).....	\$3.75 to \$4.00
Swing wire gate with steel frame complete 14 ft. long (Fig. 85).....	4.00 to 4.25
Swing board gate, board frame 14 ft. long (Fig. 83)....	4.25 to 4.50
Swing wire gate, steel frame 16 ft. long (Fig. 85).....	4.50 to 5.00
Swing wire gate pipe braced 16 ft. long (Fig. 86).....	4.75 to 5.25

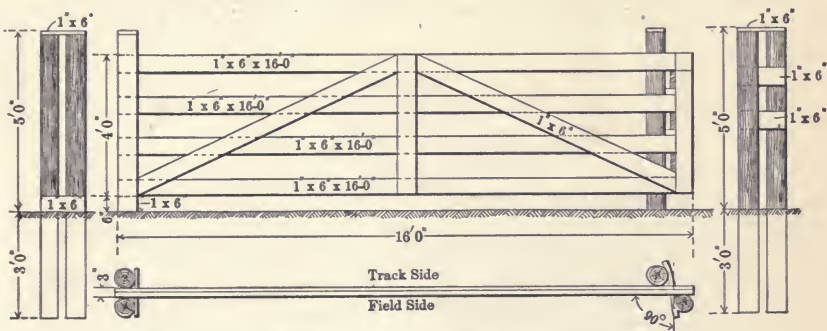

Fig. 83. Swing Board Gate.

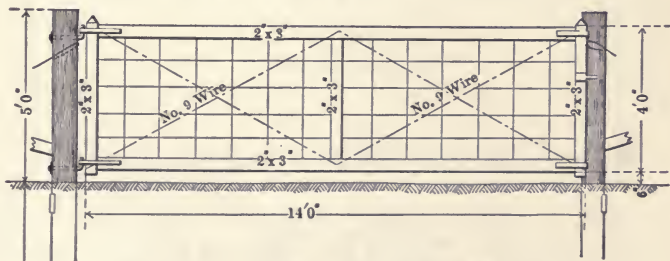

Fig. 84. Swing Wire Gate (Wood Frame).

**Wooden Gates.** (Figs. 83 and 84.) — The wooden gates are usually made of 2" × 3" frame all round with a 2" × 3" post in center and No. 9 galvanized wire mesh over, with two diagonal cross-wire ties.

The wooden swing board gate is made up of four 1" x 6" x 16' planks with 8-in. spaces between having one center and two diagonal planks 1" x 6".

**Steel Gates.** (Figs. 85 and 86.)—The steel pipe gates are made with 1½-in. steel pipe, divided into three equal panels with two vertical 1½-in. bars between, covered with No. 9 galvanized iron wire mesh with diagonal wire brace.

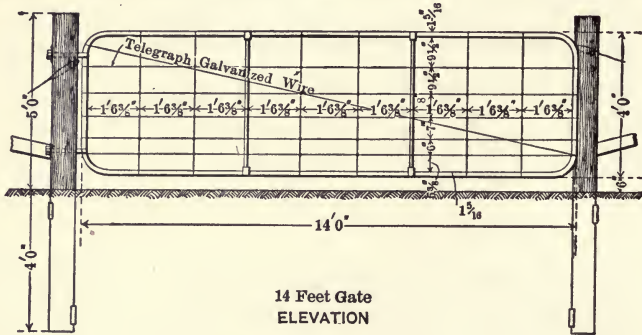

Fig. 85. Steel Gate.

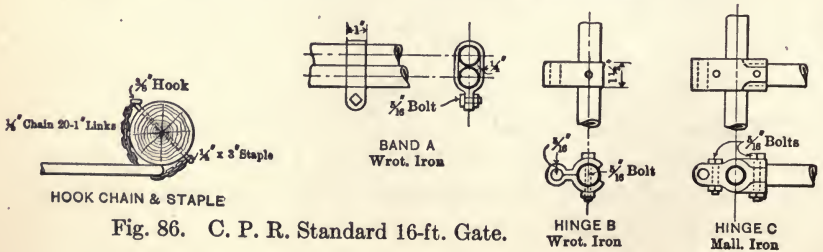
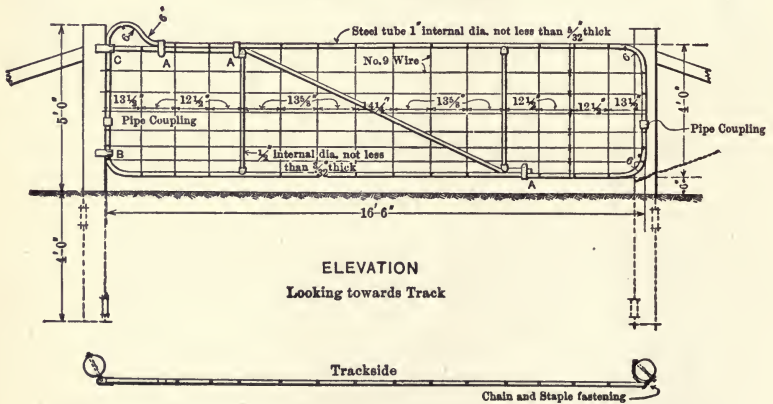

Fig. 86. C. P. R. Standard 16-ft. Gate.

**Cattle Guards.** — At public highways and other crossings cattle guards are placed on each side of the road, to prevent cattle from getting on the right of way.

They are made of various kinds of material, metal and wood being used principally. The metal guards are liable to rust unless frequently painted. The wood cattle guard is the most popular.

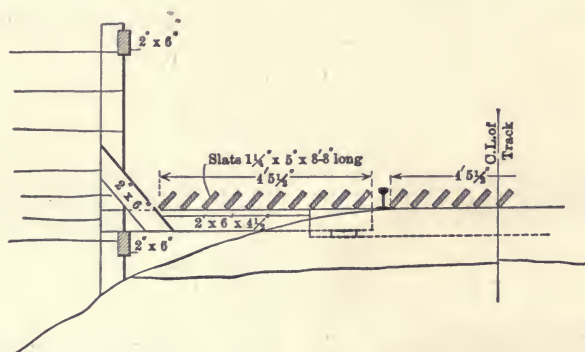

Fig. 87. Wood Cattle Guard.

**Wood Cattle Guards.** (Fig. 87.) — The common wood cattle guard consists of a number of board slats  $1\frac{1}{4}'' \times 5'' \times 8'$  nailed at about 4-in. centers to slant face wood blocks, one block at each end between each slat, 10 slats with 18 blocks forming a section; three sections are generally used, one at each side and one in the center of track, and placed each side of road crossing resting on  $2'' \times 6''$  timbers supported on 8-in. diameter cedar posts with small brace straps at the bottom and ends; the rest timbers are arranged to come about level with base of rail, so that the guard extends about 4 in. above the base of rail. The guards and fence posts are usually whitewashed when placed.

Whatever type or make the cattle guard may be it is essential that it be held down in the most rigid manner so that none of its parts can become loose and engage a locomotive pilot, a brake beam, or some other part of a passing train. There should be no pockets that will collect dust, leaves or moisture which will cause deterioration and shorten the life of the guard.

Fig. 87a illustrates two methods of placing guards, one within the right of way, the other on the public road.

**Pit Guards.** — The pit guard is usually an open culvert spanned by stringers to carry the track; their use for many reasons is not recommended.

**Metal Guards.** — Metal guards made with galvanized iron bent to form any desired type of cattle guard is usually made up in sections arranged to fasten to the track ties, the two outer sections being supported at the ends with 2" × 6" timbers nailed to 8-in. cedar posts similar to the wood guard supports.

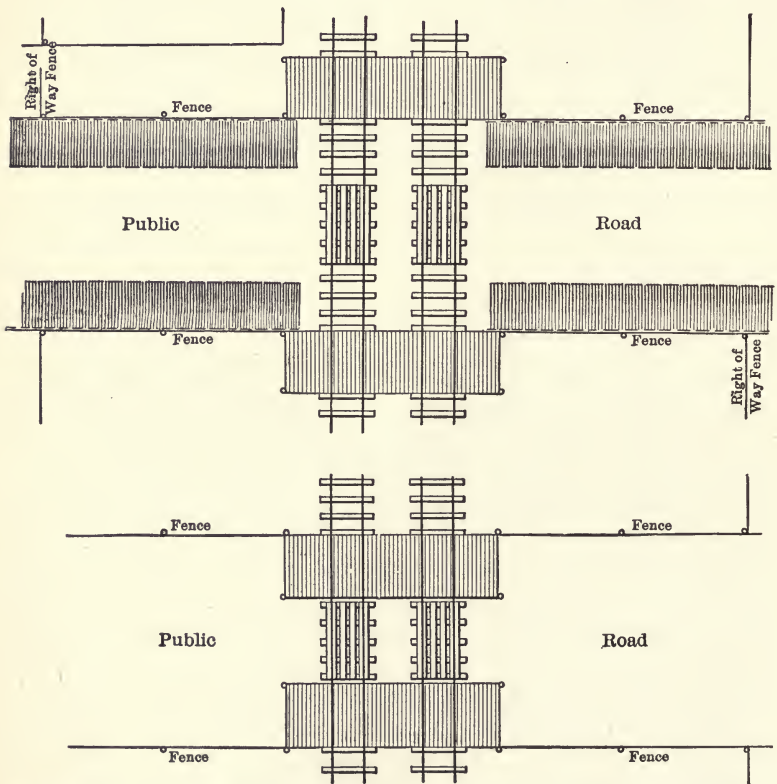

Fig. 87a. C. P. R. Method of Placing Cattle Guards at Road Crossings.

*Approximate Cost of Wooden Cattle Guards.*

SINGLE TRACK (ONE COMPLETE CROSSING, 6 SECTIONS), FIG. 88.

*Lumber:*

	Ft. B. M.
60 pcs. 1¼" × 4" × 8' 1¾" (out of 16 ft. lengths).....	200
4 pcs. 4" × 8" × 14' 0" separators to slats, etc.....	150
16 pcs. 2" × 6" × 18' 0" fence rails, braces, etc.....	288
8 pcs. 2" × 6" × 14' 0" return fence rails.....	168
	806 @ \$25 per M. \$20.15

*Hardware:*

20 lb. 20 d. cut nails @ 6¢.....	\$1.20
14 lb. 50 d. cut nails @ 6¢.....	0.85
Labor, making and installing.....	10.80
Total for one single crossing complete.....	\$33.00

If cedar posts are required at return fences add:

20 cedar posts 9 ft. long, 180 ft. @ 30¢ each	\$6.00
Labor digging holes and setting posts @ 25¢ each.....	5.00
	\$11.00

RENEWING SIX MOVABLE PANELS.

*Lumber:*

	Ft. B. M.
60 pcs. 1¼" × 4" × 8' 1¾" (out of 16 ft. lengths).....	200
4 pcs. 4" × 8" × 14' 0" separators to slats, etc.....	150
6 pcs. 2" × 6" × 9' 0" braces, etc.....	54
	404 @ \$25 per M. \$10.10

*Hardware:*

16 lb. 4-in. cut nails @ 6¢.....	\$1.08
14 lb. 5½-in. cut nails @ 6¢.....	0.82
Labor, making.....	6.00
Total for renewing 6 panels for one single track crossing....	\$18.00

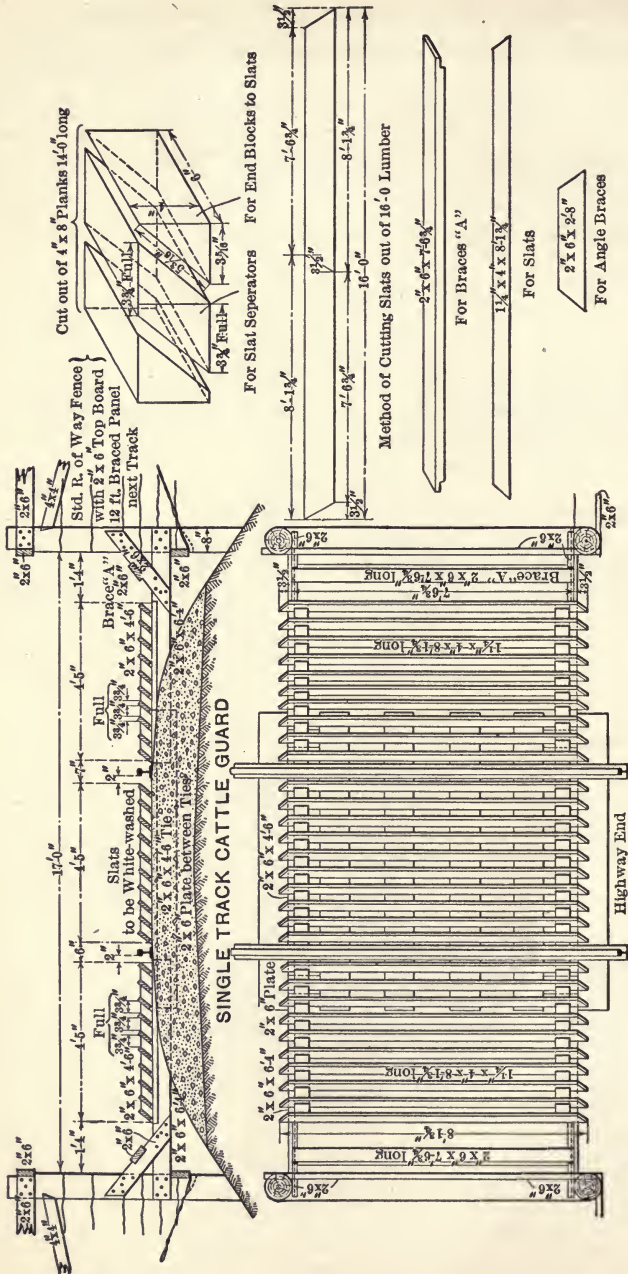

Fig. 88. C. P. R. Wooden Cattle Guards — Single Track.



*Approximate Cost of Wooden Cattle Guards (Continued).*

DOUBLE TRACK (ONE COMPLETE CROSSING, 10 SECTIONS), FIG. 89.

*Lumber:*

	Ft. B. M.	
114 pcs. 1¼" × 4" × 8' 1¾" (out of 16 ft. lengths).....	380	
8 pcs. 4" × 8" × 14' 0" separators to slats, etc.....	300	
28 pcs. 2" × 6" × 18' 0" fence rails, braces, etc.....	504	
	<u>1184</u>	@ \$25 per M. \$29.60

*Hardware:*

40 lb. 4-in. cut nails @ 6¢.....	\$2.40
28 lb. 5½-in. cut nails @ 6¢.....	1.68
Labor, making and installing.....	21.32
Total for one double crossing complete.....	<u>\$55.00</u>

If cedar posts are required at return fences, add:

16 cedar posts 9 ft. long @ 30¢ each.....	\$4.80
Labor, digging holes and setting posts 16 @ 25¢ each.....	4.00
	<u>\$8.80</u>

RENEWING TEN MOVABLE PANELS.

*Lumber:*

	Ft. B. M.	
114 pcs. 1¼" × 4" × 8' 1¾" (out of 16 ft. lengths).....	380	
8 pcs. 4" × 8" × 14' 0" separators to slats, etc.....	300	
6 pcs. 2" × 6" × 18' 0" braces, etc.....	108	
	<u>788</u>	@ \$25 per M. \$19.70

*Hardware:*

32 lb. 4-in. cut nails @ 6¢.....	\$1.92
28 lb. 5½-in. cut nails @ 6¢.....	1.68
Labor, making.....	12.70
Total for renewing 10 panels for one double track crossing.....	<u>\$36.00</u>



CHAPTER XIV.

SNOW AND SAND FENCES AND SNOW SHEDS.

**Wood Snow Fences.** — Snow fences are used in open country to prevent or minimize trouble from drifting snow blocking the track. They are usually of wood, though tree and hedge fences and earth banks are in use.

When permanent, a close or open board fence is erected on the portion of the right of way affected, 30 to 50 ft. from track. When located off the right of way, permission is usually obtained from the farmers, and portable fences are used and placed 150 feet or more from the track.

Kind.	Approximate cost.
Permanent close board fence per lin. ft.....	50 to 60¢
Permanent open board fence per lin. ft.....	40 to 50¢
Portable fence per lin. ft.....	30 to 40¢

**Permanent Close Board Fence.** — Cedar posts 8 in. diameter by 12 ft. long, placed 8-ft. centers, standing about 8 ft. 6 in. from ground line, and covered with  $\frac{7}{8}$ -in. boards to within one foot of ground with 1" x 6" cover piece over the joints at each post.

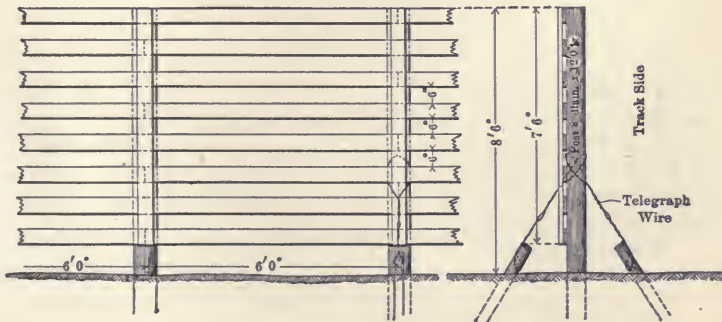

Fig. 91. Permanent Snow Fence (Open Board).

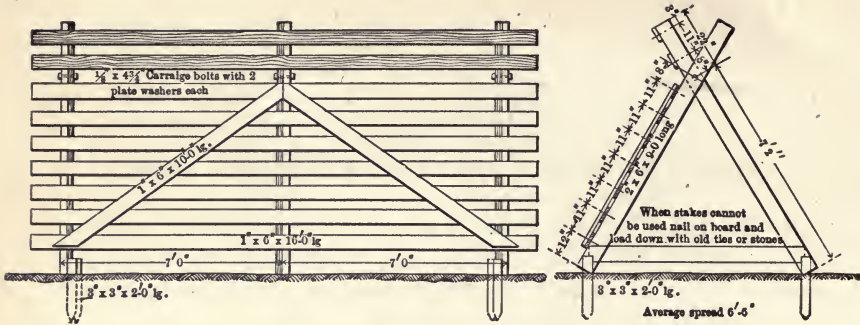

Fig. 92. Portable Snow Fence.

**Permanent Open Board Fence.** (Fig. 91.) — Similar to the close board fencing excepting that the boards are placed with 6-in. spaces between.

**Portable Fence.** (Fig. 92.) — Made in sections 14 and 16 ft. long, with triangular shaped supports 6 to 8 ft. high, and about 6 ft. spread, with 2'' x 6'' inclined main supports at 7-ft. centers, and 2'' x 6'' brace behind; when not held down by stakes to ground, 2'' x 6'' ties are used at the bottom of frame and stone piled on top.

The boards are 7/8-in. material from 6 to 8 in. wide, about 12-in. centers with 4 to 6-in. spaces between.

*Approximate estimate of cost.*

PERMANENT CLOSE BOARD FENCING.

One 16-foot Panel.

2 fence post holes @ 35¢	.....	\$0.70
2 posts 8-in. diameter, 12 ft. long @ 9¢	.....	2.16
150 ft. B. M. boarding @ \$35	.....	5.25
3 1/2 lb. 12 d. steel nails @ 8¢	.....	0.28
2 stake posts 6-in. diameter, 5 ft. long, each @ 25¢	.....	0.50
16 ft. galvanized iron guy wire	.....	0.11
Total, p. panel	.....	<u>\$9.00</u>

PERMANENT OPEN BOARD FENCE.

*One 16-foot Panel.*

2 fence post holes @ 35¢.....	\$0.70
2 posts 8-in. diameter, 12 ft. long, @ 9¢.....	2.16
97 ft. B. M. boarding @ \$35.....	3.40
1½ lb. nails @ 8¢.....	0.13
2 stake posts 6 to 8 in. diameter, 5 ft. long, each 25¢.....	0.50
16 ft. galvanized iron wire.....	0.11
Total, p. panel.....	\$7.00

PORTABLE FENCE.

*One 14-foot Panel.*

150 ft. B. M. timber at \$35.....	\$5.25
3 lb. nails @ 8¢.....	0.24
3½" × 4½" carriage bolts with washers.....	0.31
Ground stakes or bottom ties.....	0.20
Total, p. panel.....	\$6.00

**Location of Snow Fences.** — Snow fences are located more from experience based upon personal observation during winter conditions, rather than from any hard and fast rules.

A hilly, rolling or open country, generally free from vegetation, offers the greatest possibilities for the use of snow fences. The fence should be placed as nearly windward from the cut to be protected as possible. For general use a portable type is recommended.

On some roads where the land is of little value or is not in use, the company get the privilege of locating the snow fences to secure the best results, as sometimes it is necessary to place two or three parallel rows of snow fence spaced 150 to 200 ft. apart where the land slopes downward towards the cut to be protected, or where the ground rises abruptly towards the cut it may be necessary to place the fences 50 ft. or less apart.

**Picket Fence.** — The ordinary picket fence for use in yard shops, etc., consists of 8-in. cedar posts 9 to 10 ft. long, set 6 ft. above ground and 3 to 4 ft. under, at about 8-ft. centers, with 3" × 4" runners top and bottom, set about 12 to 18 in. from ground and top of posts; to these are nailed 4" × 1" × 6' vertical pointed end pickets, with spaces between varying from 1 in. to 6 in.

*Approximate cost per linear foot, 50 to 75 cents in wood.*

*Approximate cost per linear foot, \$1 to \$1.25 in wood and metal (Fig. 93).*

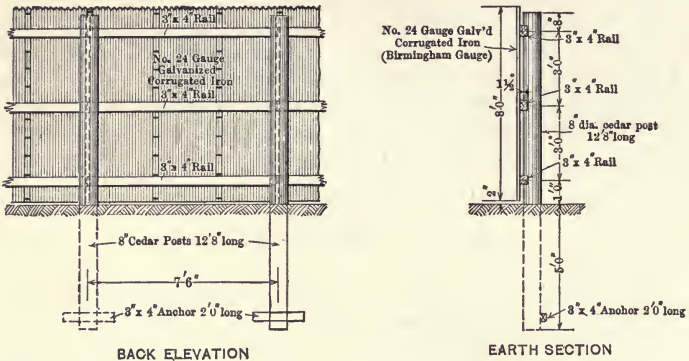

Fig. 93. Picket Fence.

**Snow Sheds.** — Snow sheds are erected principally to protect the track from snow slides, and are designed to suit the varying conditions for each particular locality.

Level fall sheds are also built where excessive heavy falls of snow are frequent.

What might be termed a typical shed, Fig. 94, built with cedar crib on the inside to retain the earth, and rock backing from the original slope line, with roof over track, and trestle bent supports on the outside. The width of roadbed is made sufficient to take summer and winter tracks. The bents on the outside are spaced 4 to 8 ft. apart and sheathed with plank 2 to 4 in. thick, depending upon the span.

Approximate cost, \$45 to \$80 per lineal foot of shed complete.

A gallery shed (Fig. 95) is built with round or square timbers in trestle fashion to carry slide protection back to slope, and the roof over the track. The gallery bents are built 4 to 12 ft. apart, with run beams to carry the roof joists and planking.

Approximate cost, \$18 to \$45 per lineal foot of shed complete.

A valley shed (Fig. 96) consists of two cribs with earth and rock backing and roof over tracks. The cribs resist the impact from sliding masses of snow that may come from either side.

Approximate cost, \$70 to \$100 per lineal foot of shed complete.

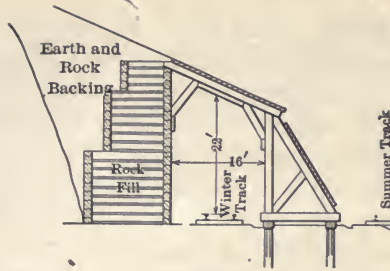

TYPICAL SHED  
Fig.94

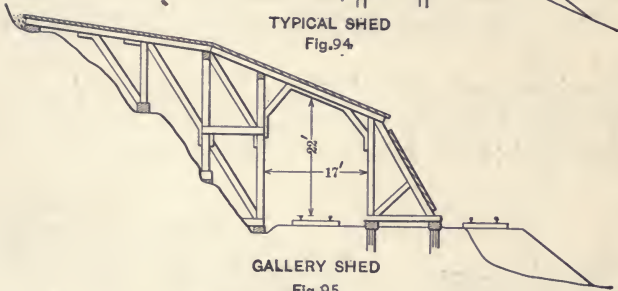

GALLERY SHED  
Fig.95

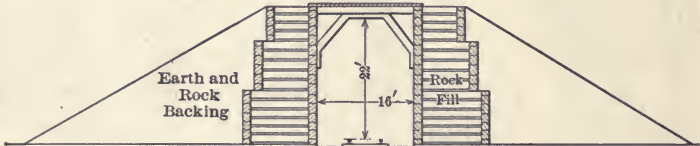

VALLEY SHED  
Fig.96

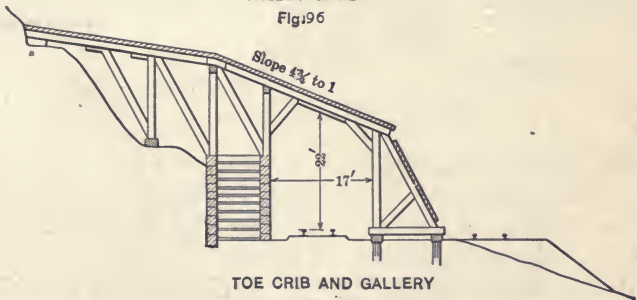

TOE CRIB AND GALLERY  
Fig.97

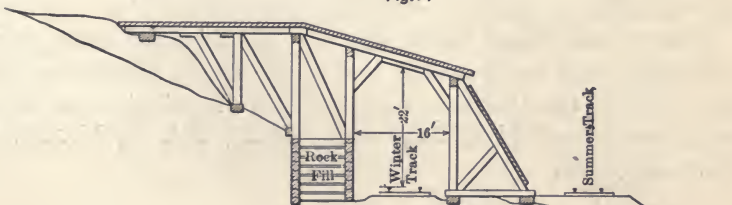

TOE CRIB AND GALLERY  
Fig.98

The crib and gallery sheds (Figs. 97 and 98) are a combination of crib and gallery trestling to take the slope with roof over track and timber trestle bents on the outside.

Approximate cost, \$30 to \$60 per lineal foot of shed complete.

Level fall shed not exposed to slides. The side walls are built of round or square timbers sheathed with plank, with double-pitched roof over track, properly braced, with openings left for ventilation. The width varies from 16 to 18 ft., and the height 20 to 22 ft. 6 in. clear, the bents being spaced from 5 to 12 ft. apart.

Approximate cost, \$10 to \$15 per lineal foot of shed complete.

The Great Northern timber sheds are shown, Fig. 99. The bents are 12" x 12" with plank braces, spaced 4 ft. center to

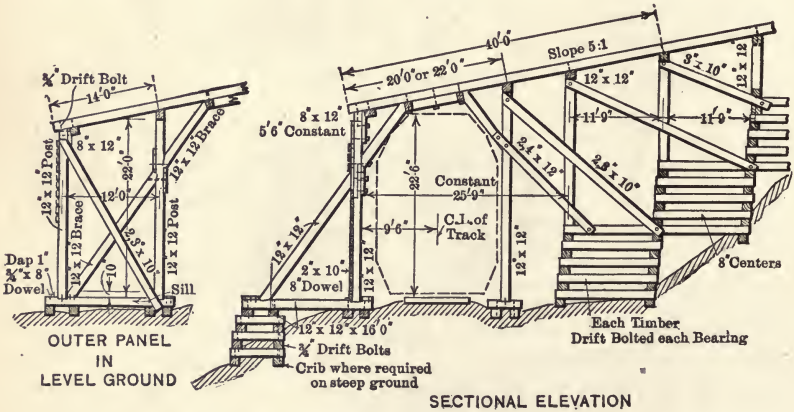

Fig. 99. Great Northern Snow Shed.

center where heavy slides are expected and 8 ft. center to center for lighter slides. On flat ground the timber crib is omitted on the outer side of the shed and the roof is extended or cantilevered only halfway over the track.

It was estimated that 6100 ft. of timber shed (100 ft. replacing old sheds) would cost \$450,000.

**Concrete and Wood Snow Sheds.** — Combination snow sheds of concrete and wood on the line of the Great Northern Railway crossing the Cascade Mountains, in Washington, as illustrated and described in *Engineering News*, Vol. 75, No. 25, is shown, Fig. 100.





It consists of a back wall of concrete (gravity type) and timber posts. The roof timbers consist of 16" × 16" transverse timbers laid close together and rest directly on the wall and are notched to fit over the projecting leg of a continuous 4" × 5" T-bar embedded in the concrete. The ends of the timbers are housed beneath a projecting ledge on the wall, with 4-in. wood blocks wedged between the timber and the ledge.

The roof timbers are securely anchored to the wall by horizontal 1½-in. bolts which pass through 2-in. sleeves and have their heads held in a 6-in. channel on the back of the wall. Upon the roof timbers is spiked a line of steel plates 7/8" × 18", in lengths of 11 ft. 11 in., secured by drift bolts. Upon these plates are riveted socket castings for the anchor bolts, the nuts being screwed up against the castings. These anchor bolts are spaced 4 ft. center to center.

The concrete wall is built in sections about 48 ft. long, with no bond between adjacent sections. The shed as shown is designed for a load of 1500 lb. per sq. ft. For a load of 1000 lb., the roof timbers are 12" × 12", the outer and inner posts are 12" × 16" and 16" × 20", respectively, and all posts spaced 10 ft. center to center.

It is estimated that 3700 ft. of combination concrete and timber snow sheds built on the west slope to replace 3000 ft. of old timber sheds will cost \$500,000.

**Concrete Snow Sheds, Great Northern Ry.**—On account of the danger from forest and other fires and heavy maintenance cost the Great Northern Railway have built fireproof sheds (about 4000 ft.) just west of the long tunnel in the Cascade Mountains, where the slides are unusually severe. They are for double track, and of reinforced concrete construction, as shown, Figs. 101 and 102.

The roof slab is figured for a load of 1100 lb. and the beams for 700 lb. per square foot of roof surface, using a stress of 500 lb. per square inch in the concrete in compression and 12,000 lb. per square inch in the steel in tension. The buttresses and anchorages are reinforced for a friction load of 100 lb. per square foot of roof, acting in the direction of the roof slope, and for a load of 700 lb. per square foot on top of the surcharged bank as produced by a slide.

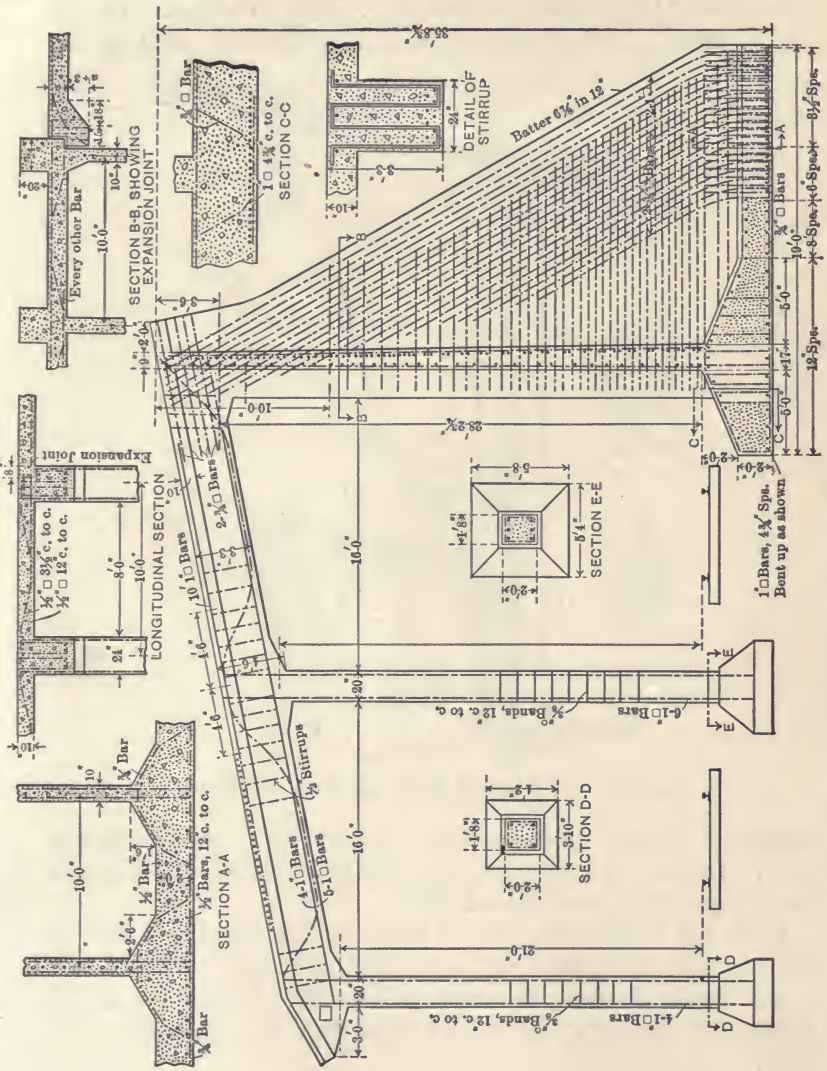

Fig. 101. Snow Shed against Earth Bank, G. N. Ry. Double-track Shed.

The columns, which are 24 in. wide parallel to the tracks, and 20 in. transversely, are 10 ft. apart center to center and carry beams 24 in. wide and 3 ft. 3 in. deep. The roof slabs are 10 in. thick. Both deformed and plain bars are used in the

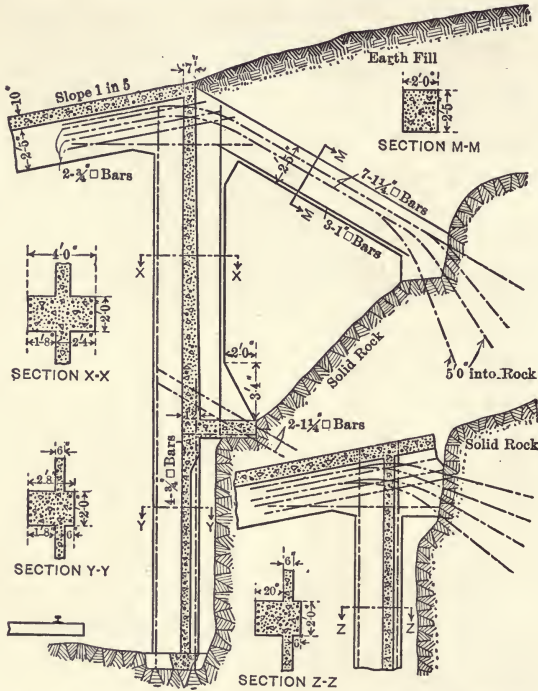

Fig. 102. Shed against Rock and Rock and Earth.

reinforcement, the deformed bars being mostly of the corrugated type. Expansion joints are placed both in the roof and in the retaining walls at intervals of 80 ft.

Different designs have been prepared for the uphill side, of the sheds in earth, rock and earth, and rock cuts. Though not shown in the drawing the earth is backfilled behind the uphill wall and is carried up to form an even slope with the roof of the shed.

In rock cuts with an earth overlay the upper part, which receives the earth load, is stronger in design than the lower part. In the lower portion a 6-in. face slab is used between the

columns while above a heavier slab is used and the wall is held back at each column by a tie with reinforcing rods anchored into the rock. The earth is backfilled up to the roof line.

In the solid rock cuts the thin face wall is carried up to the full height at a uniform thickness and the top is tied into the rock as in the previous case. This thin face wall is to protect the track from any rock which may disintegrate and break off the rock wall.

## CHAPTER XV.

## CROSSINGS AND SIGNS.

## Road Crossings.

**Farm Crossings.** — At grade crossings of public and farm roads it is necessary to make a driveway for the safe passage of vehicles over the track, for a width of 12 to 16 ft. for farms, and 20 ft. or over for public crossings. Three-inch plank is generally used of varying widths, and of the desired length, placed fairly close together between rails and one on the outer side of each rail, spiked to 2-in. shims under the planks and secured to the ties; the height of shims is made to suit the rail, and the ends of planks are usually chamfered off, and in some cases a rail is placed on its side, butting against the web of the main track rails with the base against the plank to form a flangeway. Fig. 103.

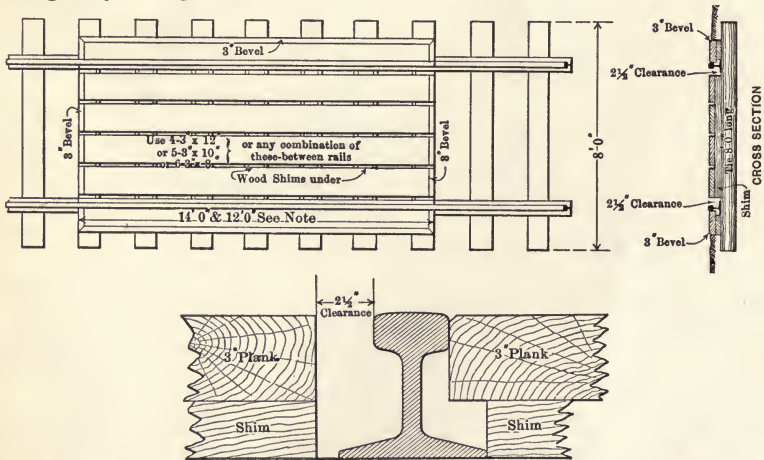

Fig. 103. C. P. R. Standard Farm Crossing.

In some cases a wooden frame is made and filled with gravel or cinders at about the same cost. This form is not recommended, as heavy loads may cause the wheels to sink into the filling when teams are passing over, and is likely to cause trouble.

Kind.	Approximate cost, single track crossing.
12-ft. wide plank crossing.....	\$7.00 to \$10.00
16-ft. wide plank crossing.....	10.00 to 15.00
20-ft. wide plank crossing.....	15.00 to 20.00
24-ft. wide plank crossing.....	20.00 to 25.00

**Overhead Farm Crossings.** — The overhead farm crossing is in the nature of a light highway bridge, and generally has to be designed to suit the varying conditions of ground actually met with. The bents are placed 20 to 30 ft. or more apart across the track, with a clear height of 22 ft. 6 in. under the crossing, and a width of 14 ft. or more. The balance of the bents are spaced 14 to 16-ft. centers on either side of track. The floor joists up to 20-ft. center to center of bents may be 3" x 12", and for double track 31 ft. 6 in. centers to centers of bents 6" x 14", at about 2-ft. centers, covered with 3-in. plank; a railing 4 ft. high or more is placed on each side of crossing

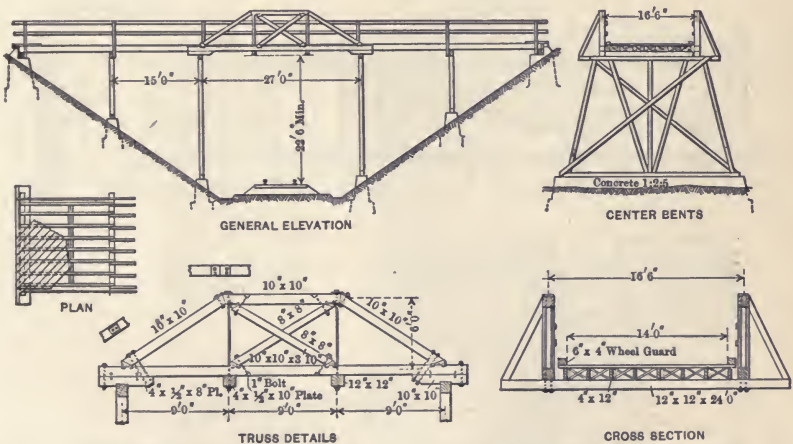

Fig. 104. Overhead Farm Crossing.

made up of 4" x 4" posts about 8-ft. centers with 2" x 3" brackets and 4" x 4" hand rail secured to posts; the floor plank is made extra long at the posts to take the bracket, and 1" x 4" fencing is used. The bents have 12" x 12" caps on three cedar piles, or 10" x 12" posts, three or more to a bent,

with flatted cedar sill under and 12" × 12" cap on top; the bents are crossed braced from sill to cap with 3" × 10" plank, one on each side, and 3" × 10" braces are also inserted longitudinally, at least one panel on each side of the track. Where desired concrete foundation is built under the bents.

Highway or overhead farm crossing, Fig. 104, has a pony truss across the track; where long timbers are scarce this is the cheaper scheme.

The cost of the crossing shown with concrete foundations under the bents 5 ft. below the ground line would be about \$2000.

**Public Road Crossings.** — At public road crossings the width varies from 16 ft. to 20 ft. and over. Where possible the crossing should be placed between rail joints. Old rails are used to make the flange way which must not be too wide, for horses hoofs catching in the gutter.

Fig. 105 illustrates the C. P. R. wood plank crossing and the estimated cost of same 16 ft. wide by 8 ft. is \$15.

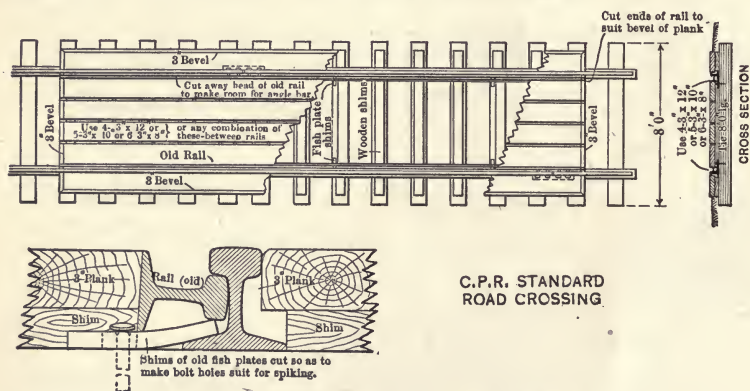
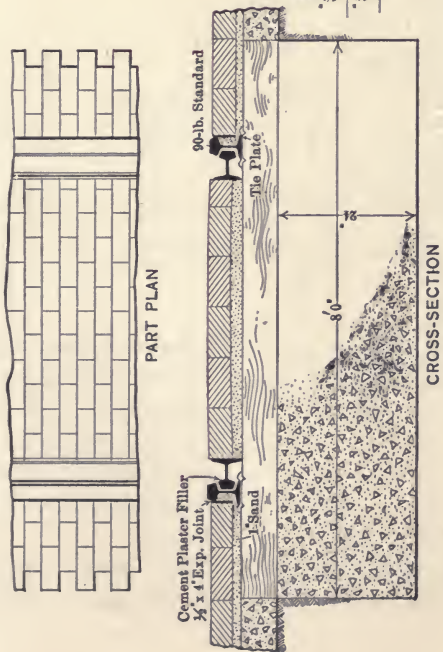

Fig. 105. C. P. R. Wood Plank Crossing.

**Permanent Paved Crossing.** — A design for a pavement railway crossing, Fig. 106, as illustrated in the *Eng. News*, Mar. 2, 1916, was devised by G. V. McClure, City Engineer, Oklahoma, Okla.

By making a run off on each side of the concrete foundation a cushion of ballast is obtained excepting at the crossing proper which is built solid. The concrete is 2 ft. deep and 8 ft. wide





PART PLAN

CROSS-SECTION

PART LONGITUDINAL SECTION

Fig. 106. Pavement Construction over Railway Crossings, Oklahoma City, Okla.

under the track and is sloped off on either side 1 in 10 longitudinally. The ties over the crossing are embedded in concrete and the paving blocks are laid on a 1-in. sand cushion.

**Highway Crossing Alarm Bell.** (Fig. 107.) — At highway crossings where traffic does not warrant a watchman or safety gates, an electric alarm bell attached to the road-crossing sign, or erected on a special iron or wood pole, is often used, arranged so as to ring ahead of an approaching train; a light also is sometimes provided above the bell. The track rail joints are bonded for a distance of 1000 to 3000 ft. on either side the crossing and insulated for battery and bell circuit, a battery being necessary at each end of the bonded track and one at foot of bell post.

Average cost for installing crossing gates.....	\$700
Expense of flagman per annum, averages.....	600
Installing signal bells, each averages.....	500
Annual maintenance for each bell.....	100
Cost of installing gate protection, averages.....	475
Cost of installing automatic flagman, averages.....	600
Annual maintenance charge for each, averages.....	100

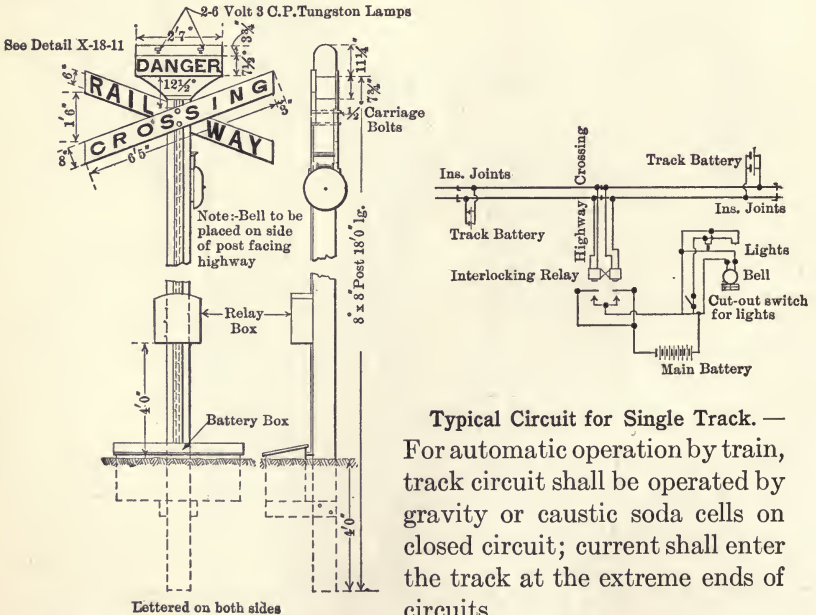

Fig. 107. Highway Crossing Sign and Alarm Bell.

**Typical Circuit for Single Track.** — For automatic operation by train, track circuit shall be operated by gravity or caustic soda cells on closed circuit; current shall enter the track at the extreme ends of circuits.

Bell ceases ringing when last wheels pass crossing.

**Safety Crossing Gates.** — At public road grade crossings it is sometimes necessary to place safety gates, consisting of iron posts placed at the curb of roadway parallel with track to which are connected the main and sidewalk arms, usually of wood, that stretch over and protect the crossing. They are operated by hand crank at gate level, or by hand lever or compressed air from a tower (sometimes a number of crossings are operated from the one tower), arranged so that the gates cannot be opened or closed excepting by the operator. The connections for operating the gates simultaneously are either placed underground or overhead as desired.

The gates are usually located 8 to 10 ft. clear of the nearest rail, with the elevated tower on one side or between tracks when convenient.

The span of gates varies to suit conditions. They are made usually in two-post or four-post crank, level or pneumatic types, the two-post style being used when the road is not too wide, and four-post construction for large openings. The smaller the span, other things being equal, the easier will the gates be operated.

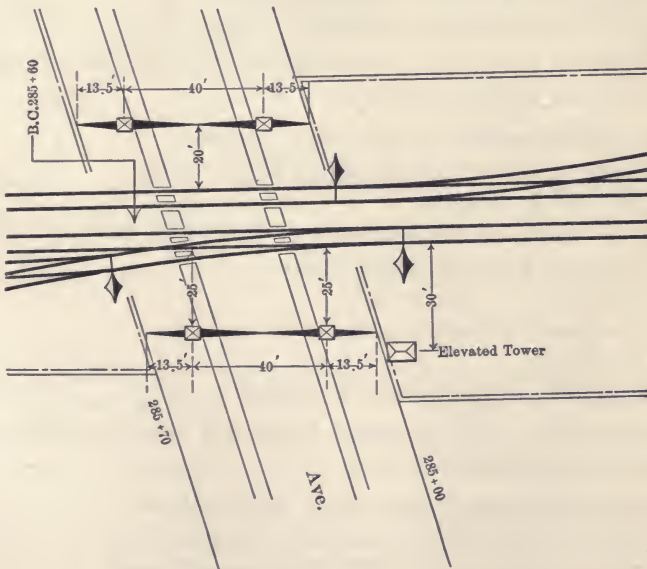

TABLE 101. — SAFETY GATES.

Kind.	Approximate cost.	Actual cost.
Two-post crank gates with watchman's shanty complete.....	\$300.00 to \$400.00	.....
Four-post crank gates with watchman's shanty complete.....	400.00 to 500.00	.....
Two-post lever gates with wood tower and connections complete.	450.00 to 650.00	.....
Four-post lever gates with wood tower and connections complete.	600.00 to 800.00	.....
Two-post pneumatic gates with wood tower and connections complete.....	500.00 to 700.00	.....
Four-post pneumatic gates with wood tower and connections complete.....	700.00 to 900.00	.....

The above prices are for wood foundation throughout.

**Two-post crank gate** would consist of —

- One cast-iron power or crank post,
- One cast-iron dead post,
- Two bifurcated wooden main and sidewalk arms,
- Two shafts,
- Piping, wood or concrete foundations,
- Watchman's shanty and bells if desired.

A four-post crank gate, excepting for the first and last items, would be double the above.

**Two-post lever gate** would consist of —

- Elevated tower with posts and foundations,
- Two cast-iron posts,
- Two bifurcated wooden main and sidewalk arms,
- One lever stand with two levers,
- Chain and rod connections,
- Gatepost foundations and ducts,
- Installation,
- Bells for arms and tower if desired.

A four-post lever gate would be double the above excepting the first and last items.

**Two-post pneumatic gate** would consist of —

- Elevated tower with posts and foundations,
- Two cast-iron posts with locking connections,

- Two bifurcated wooden main and sidewalk arms,
- One air-pump and valves (unless air can be supplied),
- Piping and connections,
- Gatepost foundations and ducts,
- Installation,
- Bells for arms and tower if desired.

A four-post pneumatic gate would be double the above excepting the air-pump and first and last items.

The elevated tower for crossing gates would cost from \$150 to \$200 each, in wood.

Generally speaking the lever crossing gate is more positive in action than the pneumatic type; the pneumatic type under certain conditions is not always satisfactory.

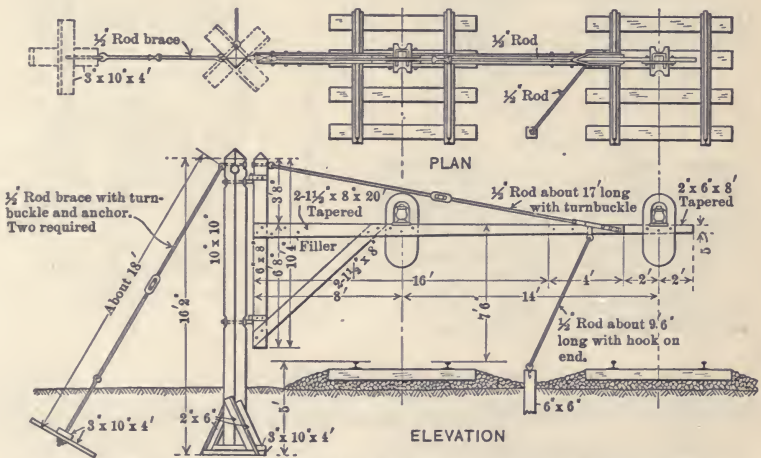

Fig. 108. Standard Gate for Suburban Crossings, Virginian Ry.

### Suburban Crossing Gates.

The standard gate for suburban railway crossing, Virginian Ry., Fig. 108, consists of a 10" x 10" post set into the ground with 3" x 10" x 4" sill support and 2" x 6" braces held at the top and anchored into the ground with a 1/2-rod brace as shown; the gate is made of 6" x 8" upright, a tapered horizontal arm with brace of 1 1/2" x 8" material held by 1/2 diagonal tension rod at top. The gate is secured by a 1/2 rod from the tapered

bar and hooked to a 6" × 6" block set into the ground. The approximate cost of one gate in place complete would be about \$15.

**Virginian Ry. Standard Watchman's Cabin.** — The standard cabin for suburban railway crossings, Virginian Ry., Fig. 109, is 6 ft. square and 8 ft. high from floor to wallplate; the frame rests on 6" × 8" sills; the vertical studs, horizontal girts, rafters and ties are 2" × 4", and the frame is covered by 1" × 7" boards as shown on the plan; the floor is of 2-in. plank nailed to the sills, and the roof is covered with 1 sheathing and finished with shingles on top; there are three fixed windows and one

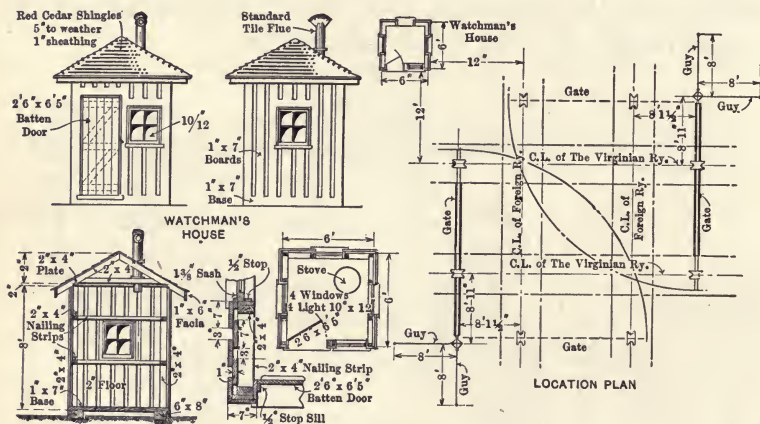

Fig. 109. Watchman's Cabin.

2' 6" × 6' 5" batten door; a small stove is provided the pipe of which is connected to a tile flue.

The approximate cost complete under ordinary conditions would be about \$45.

For description of gates see page 291.

**Flagman's Concrete Cabin, Erie R. R.** — The switchman's and flagman's concrete house, as used on the Erie Railroad, is shown, Fig. 110. The walls are 4 in. thick with wire reinforcement and  $\frac{3}{4}$ -in. round rods at the angles.

The concrete is composed of coarse sand and gravel and cement, in the proportion of about 1 to 3, machine mixed. In order to pour readily, the mixture is made to thickness of thick

cream. The concrete work contains 3 cu. yd. coarse sand and gravel, 6 barrels Portland cement, 150 lin. ft.  $\frac{3}{4}$ -in. round and 225 sq. ft. expended metal  $1\frac{1}{2}$ -in. mesh No. 12 gauge.

The cost of this type of shelter is about \$125.

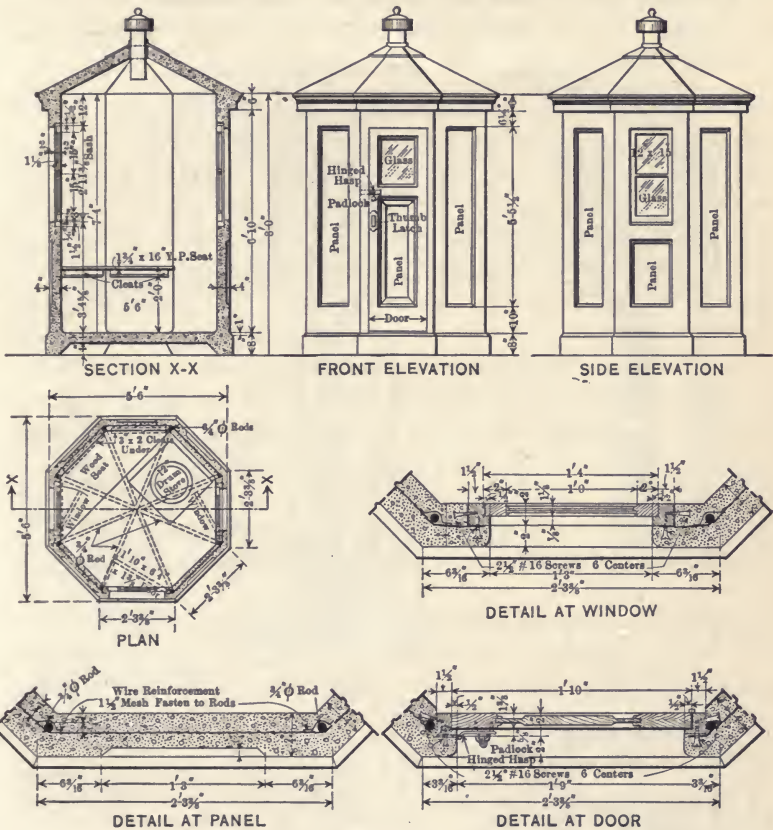

Fig. 110. Watchman's Cabin.

**Tower for Crossing Gates.** — The C. P. R. standard tower for crossing gates is illustrated, Fig. 111, and consists of four old steel rails bent and shaped so as to form a solid post on which the small frame enclosure is set. The rail post is supported on an 8-ft. square slab of concrete, tapering to about 3 ft. square at the ground line. The frame house on top of the tower is made up of 4" x 6" joists, 2" x 4" wall plates, 2" x 4" roof

joists and  $\frac{7}{8}$ -in. sheathing and lining for the wall and roof covering; the roof is finished with asbestos shingles. A trap door and an ordinary signal tower ladder is provided including a cast iron smoke stack.

The estimated cost of this tower complete is \$250.

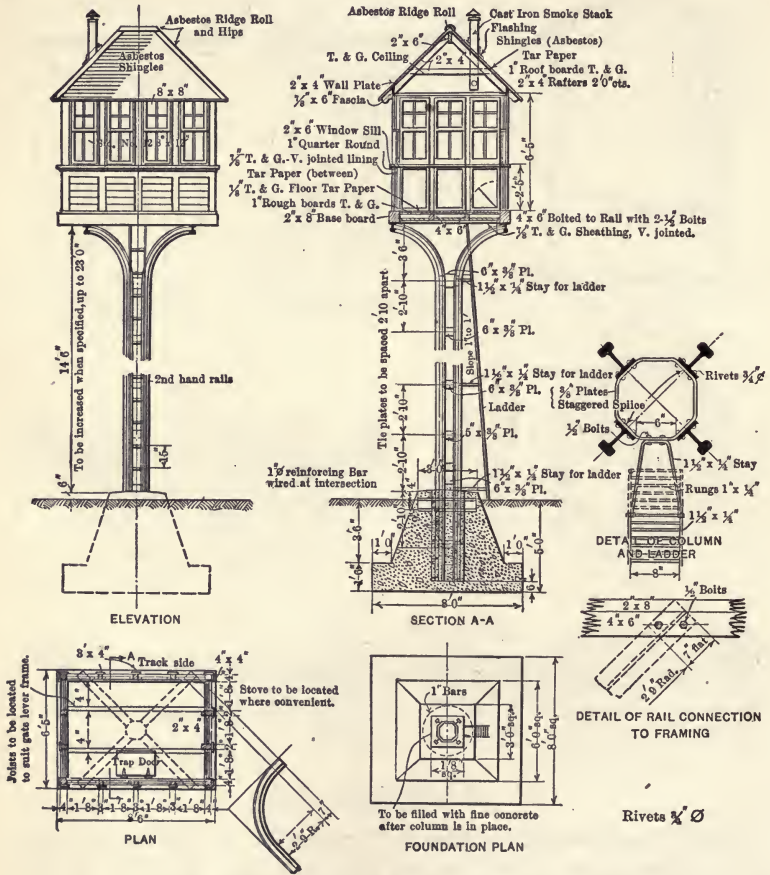

Fig. 111. C. P. R. Tower for Crossing Gates.

**Cost of Installing Gates and Tower.** — The estimated cost of installing the above tower including the gates as shown on page 291 is about \$1400, detailed as follows:



Gate stands, deflecting boxes and lever machine . . . . .	\$ 425.00
Piping 1-in. and 2-in. bolts, washers, etc., for gate stands. . . . .	50.00
Tower complete . . . . .	250.00
Miscellaneous, including stove, pipes and connections . . . . .	85.00
Pine carriers . . . . .	30.00
Labor . . . . .	450.00
	<u>\$1290.00</u>
Supervision and contingencies, about 10 per cent . . . . .	110.00
Total . . . . .	<u>\$1400.00</u>

N. P. Ry., two post tower, Fig. 112, consists of two 10" × 12" posts set on 6" × 8" × 9' ties, 6 ft. underground. The posts are braced laterally below the ground line with 6" × 6" and 6" × 8" timbers bolted together. The cross sills on top of the posts are 8" × 8" and the braces 6" × 6"; the floor sills are also 6" × 6" and the studding, wall plates and rafters 2" × 4". The siding floor and roof covering is 1" × 6" D. & M. boards with a shingle roof.

The approximate cost of this tower complete is \$150.

**Track Signs.** — Track signs in general are considered to be more of an eye-sore than an ornament on the right of way and the tendency at present is to limit their use and to make those that are necessary as inconspicuous as possible; as a rule they invite target practice by gunshot or throwing of stones, and in some hunting locations, if wooden signs are used they are soon shattered.

The signs in general use are made of cast iron, sheet steel, concrete, enamelled iron and wood, with concrete, steel or old boiler tube and wooden posts. The wooden signs and posts, used almost exclusively, are, however, gradually disappearing, for work of this character, on account of the higher price of timber, its short life and high maintenance cost.

The desire also to get away from the everlasting painting of signs has led to a number of devices, such as concrete signs with the letters or numbers made in a black mixture, the cast iron sign with the letters or numbers cast on them, and the punched out sign where the letters or figures are punched out and daylight takes the place of paint.

The punched out signs were introduced by the C. P. R. for their bridge and culvert numbers, whistle posts, mile plates and slow and stop signals, snow plow signs, section numbers, etc., and a short description of each may be of interest:

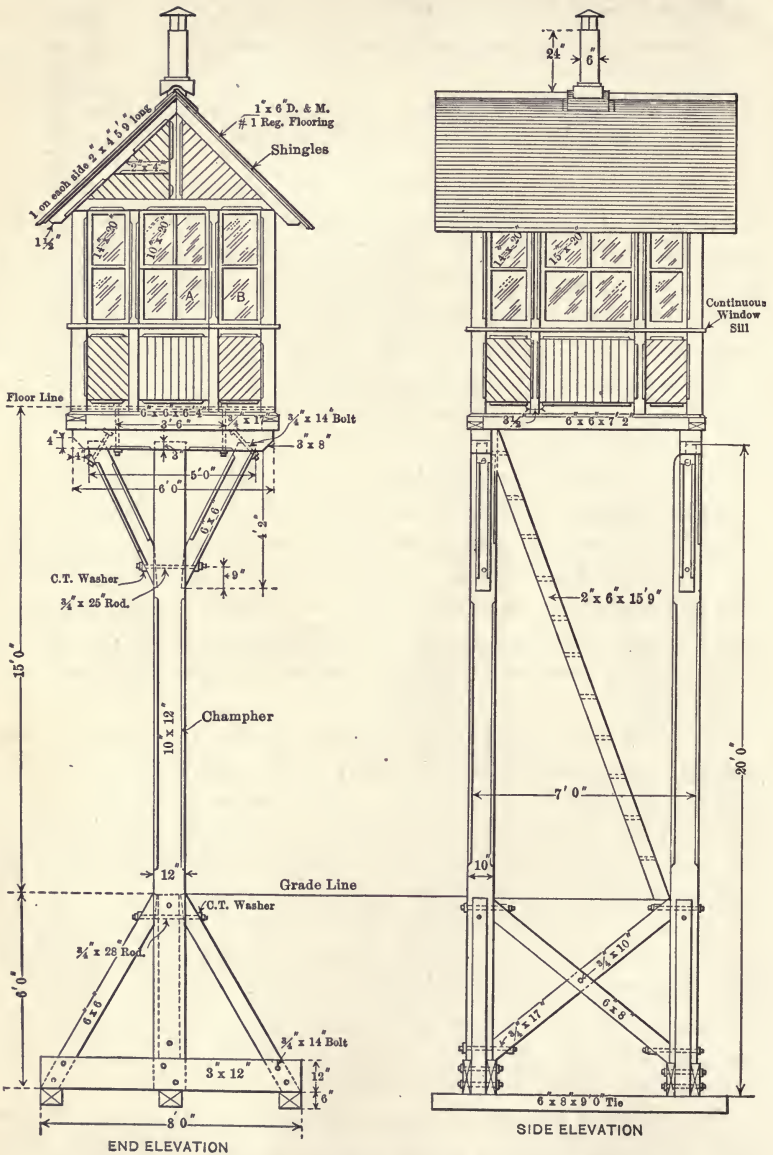
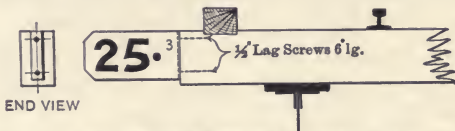

Fig. 112. N. P. Ry. Two-post Tower for Crossing Gates.

Bridge Numbers.

Fig. 114 shows the punched out sign now used in place of the wooden sign. For new bridges it is furnished with the bridge and costs 75 cents; when replacing a wooden sign the cost is \$1. There is practically no maintenance to this sign as it is a part of the bridge and is painted when the bridge is painted; there is no lettering and the little paint required to cover it when the bridge is being painted is practically nothing.



Note:—One Number Plate on Mile Post side of each Bridge about centre. When Bridge is over 500 ft. long place Number Plate at each end. All plates painted same color as Bridge.

For detail of punched out figures see F-14-18<sub>2</sub>

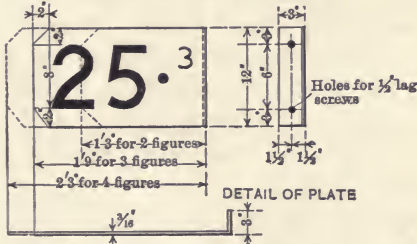

Fig. 114. Punched out Bridge Numbers (F-14-18-2).

It is figured that the punched out metal bridge sign will outlast the wooden sign four to one; therefore the saving from renewals and repainting is quite large. For example if the wooden sign lasts 12 years, the metal sign will last 48 years; the saving during this period for a punched out sign, figuring that the wood signs are repainted every three years, would be \$16. The figures are as follows:

*Cost of Wood Signs (48 Years).*

Wood signs, 4 @ \$1.25.....	\$ 5.00
Painting and lettering (every 3 years), 16 @ 75¢.....	12.00
Total cost of wood sign in 48 years.....	<u>\$17.00</u>

*Cost of Metal Sign (48 Years).*

1 punched out metal sign.....	\$1.00
Nil.....	
Total cost of punched out sign in 48 years.....	<u>\$1.00</u>

The saving of \$16, or even half or quarter of this amount, on each bridge sign on a large system amounts to a very big sum and when it is worked out for other signs, on the same basis, such as mile boards, snow plow signs, whistle posts, etc., the saving is bound to be considerable.

**Culvert Number Posts.** — Culvert number posts have been abandoned on the C. P. R. The old sign consisted of wood post with the numbers painted at the top, or an old boiler tube was used flattened at the top and painted the same as the wooden post; the posts were painted in black and white.

The punched out sign, Fig. 123, consists of an old boiler tube flattened at the top with the figures punched out, only black paint is used. The cost is 75 cents each.

**Snow Plow and Flanger Post Signs.** — This type of sign is to indicate that wings, plow points or flange blades have to be brought to clear. On the C. P. they are placed 8 ft. from rail at crossings where planking is maintained in winter, and 150 ft. each way on engineer's side of track, from all bridges, tunnels, rock cuts, etc., where necessary to clear wings, etc.

At switches, public road crossings or stations, however, the switch stand, public road crossing sign or station building indicates the obstruction, and snow plow signs are not considered necessary at such points.

The steel punched out sign, Fig. 117, consists of an old 2-in. boiler tube post with a  $\frac{1}{8}$ -in. plate on top. The post and plate are painted black and the discs are punched out. The cost is \$1.25 each.

It may be mentioned that the punched out discs are particularly good for this type of sign, as in winter it shows up white against the black plate. Its economy consists in getting away from painted discs and the use of one color instead of two.

**Stop and Slow Post Signs.** — On the C. P. these are placed on engineer's side of track 8 ft. from rail and 400 ft. from all grade crossings, junctions, drawbridges, etc., not protected by interlocking where trains must come to a full stop or 2000 ft. at points for slow signs when trains must be under full control.

In the old wooden stop and slow signs the posts were 6"  $\times$  6", with 1-in. thick blades bolted to the posts. The letters were

painted in white on red background for stop blades and black letters on yellow background for slow blades, balance white.

The new stop and slow signs, Fig. 114a, are built of old boiler tubes, with  $\frac{3}{8}$ -in. metal blades. The letters are punched out, the stop blade is painted red and the slow blade yellow, balance white. The cost is \$2 each.

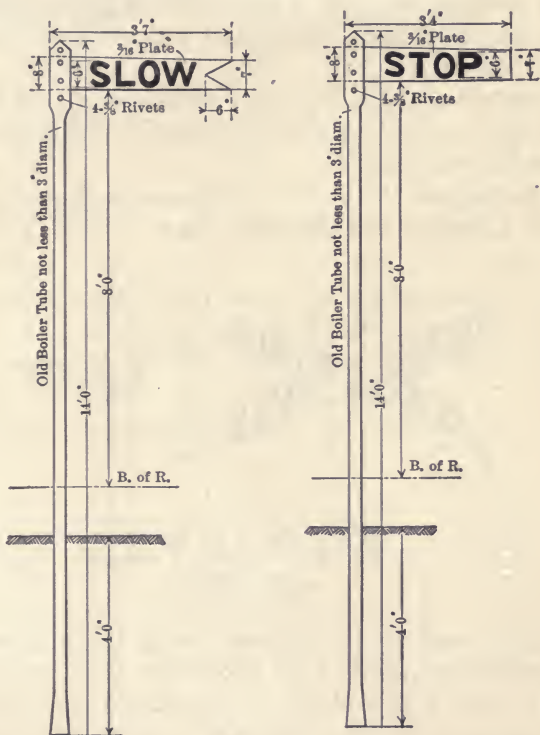

Fig. 114a.

**Section Post.** — Section posts are used to mark the boundary of each section foreman's territory. The old post consisted of a 4" × 4" upright and 1" × 18" × 10" board placed 7 to 8 ft. from the rail; the letters were painted black and the pole white.

The new sign consists of a punched out plate which is placed on the nearest telegraph pole, as shown, Fig. 119. The pole behind the plate is painted white and the plate black. The sign costs about 40 cents.

**Mile Board Signs.** — On the C. P. R. the mile board signs are placed on the nearest telegraph pole.

The metal sign, Fig. 120, is made of  $\frac{1}{8}$ -in. plate with the mile number punched out. The plate is painted black. The cost is 75 cents each.

**Whistle Posts.** — Whistle posts are erected on each side of and at a distance of about  $\frac{1}{4}$  mile from all public and highway crossings at grade, blind curves and tunnels, 8 ft. from rail on engineer's side.

The punched out sign, Fig. 121, consists of an old 2-in. boiler tube and  $\frac{1}{8}$ -in. steel plate with the letter *W* punched out. This sign costs 90 cents each.

The following are the C. P. R. standard track posts and signs.  
**Railway Crossing and Highway Sign.** (Fig. 115.) — Placed

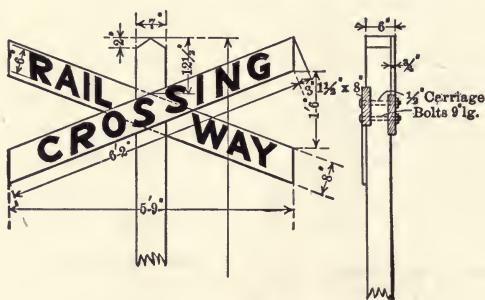

Fig. 115.

at all public road grade crossings facing the approach. Post 7 to 9 inches round, about 12 ft. above top of rail, set into ground about 4 ft., two 8-inch planks on top placed crosswise with the words "Railroad Crossing" marked in plain block letters 6 in. high on each side.

*Approximate cost in wood complete, \$4.00 to \$5.00.*

**Railway Crossing, Railway Junction and Drawbridge Sign.** (Fig. 116.) — Post 7 to 9 inches round, about 10 ft. 6 in. above top of rail and 5 ft. in ground, with four boards on top placed diamond shape with the words "Railway Crossing One Mile" in plain block letters 6 in. high, or "Drawbridge Crossing" or "Junction Crossing" in place of "Railway Crossing."

*Approximate cost in wood complete, \$3.50 to \$4.50.*

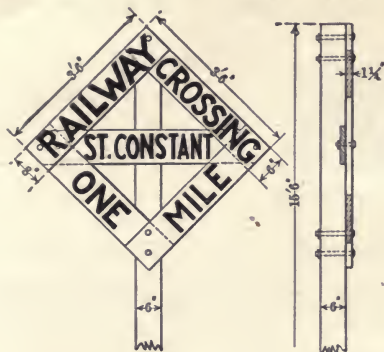

Fig. 116.

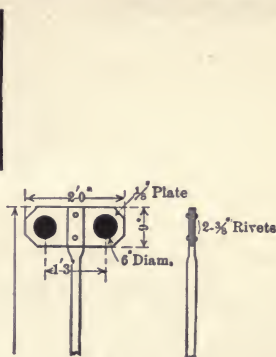

Fig. 117.

**Flanger Post.** (Fig. 117.) — Placed 8 ft. from rail, and 150 ft. from obstructions where points and flangers must be lifted. Post 2-in. old boiler tube 7 ft. 6 in. above rail set 3 ft. 6 in. below ground, with  $\frac{1}{8}$ "  $\times$  2' plate on top, having two round black disks, one on each side punched out.

*Approximate cost in metal complete, \$1.00 to \$1.25.*

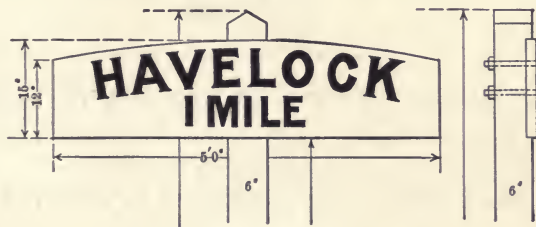

Fig. 118.

**Station Mile Board.** (Fig. 118.) — Placed 10 ft. from rail, 6 to 8 in. round, post about 9 feet above rail and set in ground 4 ft., with board 12 to 15 in. wide, 5 ft. long, with "Name of Station" and 1 mile under in plain block letters.

*Approximate cost in wood complete, \$2.00 to \$2.50.*

**Section Number.** (Fig. 119.) — Placed 7 ft. above rail on

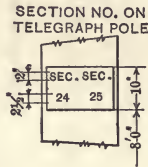

Fig. 119.

telegraph post 10" × 18" board, with the two section numbers marked.

*Appropriate cost complete, \$0.90 to \$1.00.*

**Mile Board.** (Fig. 120.) — Attached to telegraph pole about

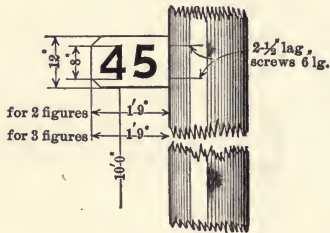

Fig. 120.

10 ft. above ground. A 10" ×  $\frac{1}{8}$ " plate with the mile number punched out, and attached to the nearest telegraph pole.

*Appropriate cost in metal complete, 50 to 75 cents.*

**Whistle Post.** (Fig. 121.) — Placed 7 ft. from rail and one-

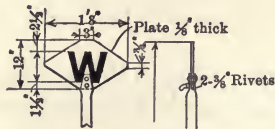

Fig. 121.

fourth mile from public road crossings. A  $\frac{1}{8}$ -in. plate standing 5 ft. above rail, and set 3 ft. in ground; the letter "W" is punched out.

*Appropriate cost in metal complete, 75 to 90 cents.*



**Trestle Number.** (Fig. 122.) — Placed in center of structure

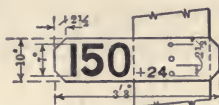

Fig. 122.

on milepost side. 12'' × 36'' plate with the number punched out and bolted to one of the ties outside of the guard.

*Approximate cost in metal complete, 75 cents to \$1.*

**Culvert Number.** (Fig. 123.) — 4'' × 4'' square post stand-

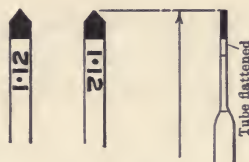

Fig. 123.

ing 6 ft. above ground, 8 ft. from rail, with 9'' × 24'' board having the Culvert number painted on in plain block letters.

*Approximate cost in wood complete, 80 to 90 cents.*

**Trespass Sign.** (Fig. 124.) — Six-inch round post or old boiler

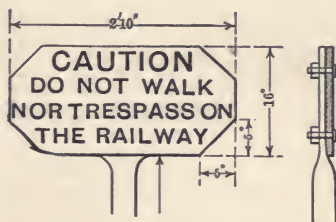

Fig. 124.

tube standing 5 to 6 ft. above the rail and about 4 ft. in ground, with 18'' × 30'' board on top, having the words "Caution," "Do not trespass" painted in plain block letters.

*Approximate cost in metal complete, \$1.50 to \$1.80.*

**Elevation Posts.** (Fig. 125.) — 4" × 4" posts standing about level with top of rail, placed on the outside, and at the beginning and end, of curves and spirals about 6 ft. from outside rail, with the letters **E** and **O** under facing tangent, and **G** and **O**

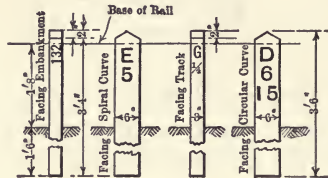

Fig. 125.

under facing track, on tangent end of spirals, and the letter **E** with elevation under, facing spiral curve, and **G** with excess gauge marked under, facing track, and **D** with degree of curve under, facing circular curve.

*Approximate cost in wood complete, 40 to 50 cents.*

**Rail Rack Posts.** (Fig. 126.) — 6" × 15" posts made up of old stringers with three 5-inch steps at top, to hold spare rails;

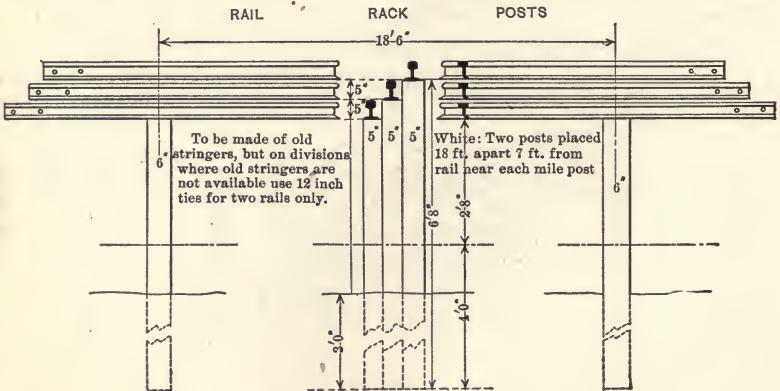

Fig. 126. Rail Rack Posts.

posts are set 18 feet apart 7 feet from rail, and set about 3 feet in ground.

*Approximate cost in wood complete, 75 cents to \$1 per pair.*

**Bridge Warning or Tell Tale.** (Fig. 127.) — Placed over the track 100 ft. or thereabouts from all overhead obstructions less than 22 ft. 6 in. clear height above top of rail. 8 by 8 post standing about 26 ft. above rail and about 5 ft. in ground with

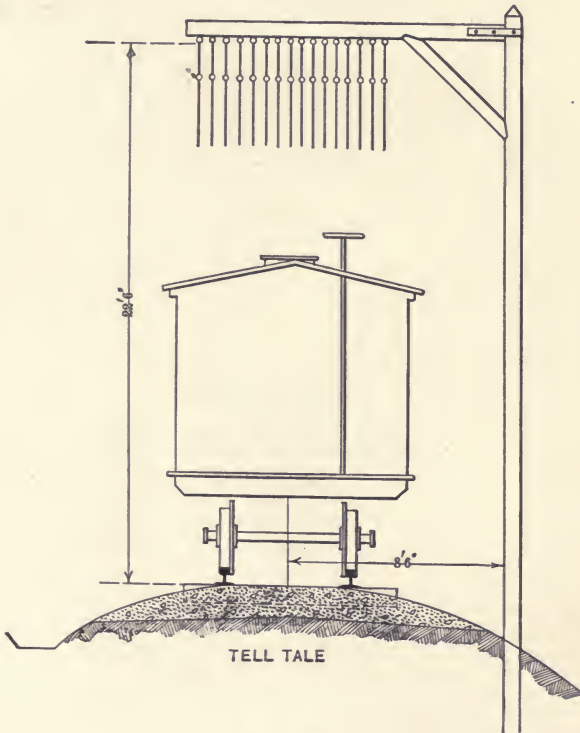

Fig. 127.

6"  $\times$  6" horizontal arm on top 13 ft. long, fastened to post with iron strap and 6 by 6 brace; from the arm are suspended sixteen  $\frac{3}{8}$ -in. sash cords 3 ft. 6 in. long each, well bound at the bottom and looped to one-half inch by 2-ft. long double eye bolts, hooked to screw eye bolts fastened to the horizontal bar.

*Approximate cost complete, \$15 to \$18.*



PART TWO.  
ROADWAY BUILDINGS.



## CHAPTER XVI.

## STATION AND OTHER BUILDINGS.

**Passenger Stations.** — In locating passenger stations it is desirable to place them throughout on one side of the right of way as far as possible, to allow for additional extra tracks at a future time that will not involve the moving of the stations and platforms; where it cannot be conveniently done the platform should be made wide enough so that it only shall be affected in the case of a future track. The same remarks apply to water tanks, coaling chutes, and similar structures.

The type of station to adopt will depend very much on local conditions, the size of the town and the kind and amount of traffic expected, etc. The following illustrations give a wide range of choice for varying conditions and the usual accommodation provided for the ordinary run of stations, including a brief description of their construction and the probable cost of such structures.

**Depot, I. C. R. R.** (Figs. 129, 130 and 130a.) — The station is of brick with white limestone trimmings and red tile roof flared at the eaves. The circular full glass bay at the south end of the waiting room gives a conservatory effect and provides a pleasing outlook. The accommodations for the public are conveniently arranged.

The roof is designed to project over the platform immediately in front of the depot, in such a way that the platform extension becomes a shed and fits in architecturally with umbrella sheds when constructed.

The average cost of a station of this character including the shelter roof and platform would be about \$14,000.

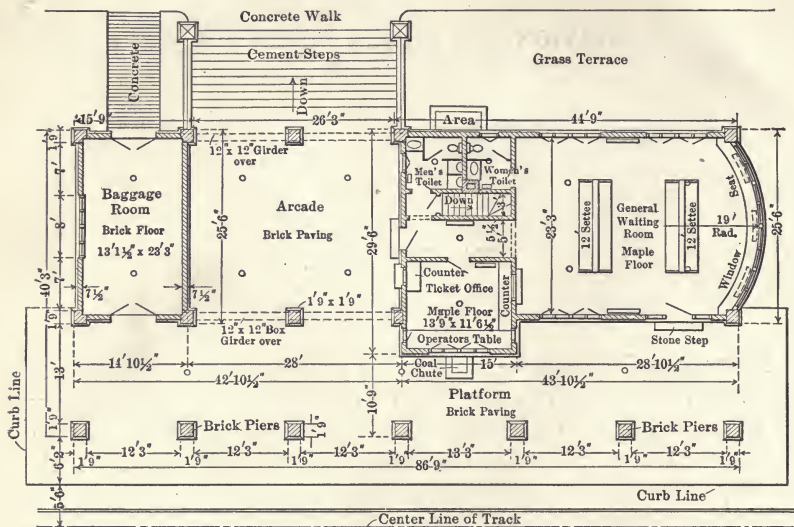

Fig. 129. Floor Plan, I. C. R. R. Station.



Fig. 130. General View.



Fig. 130a. End View.



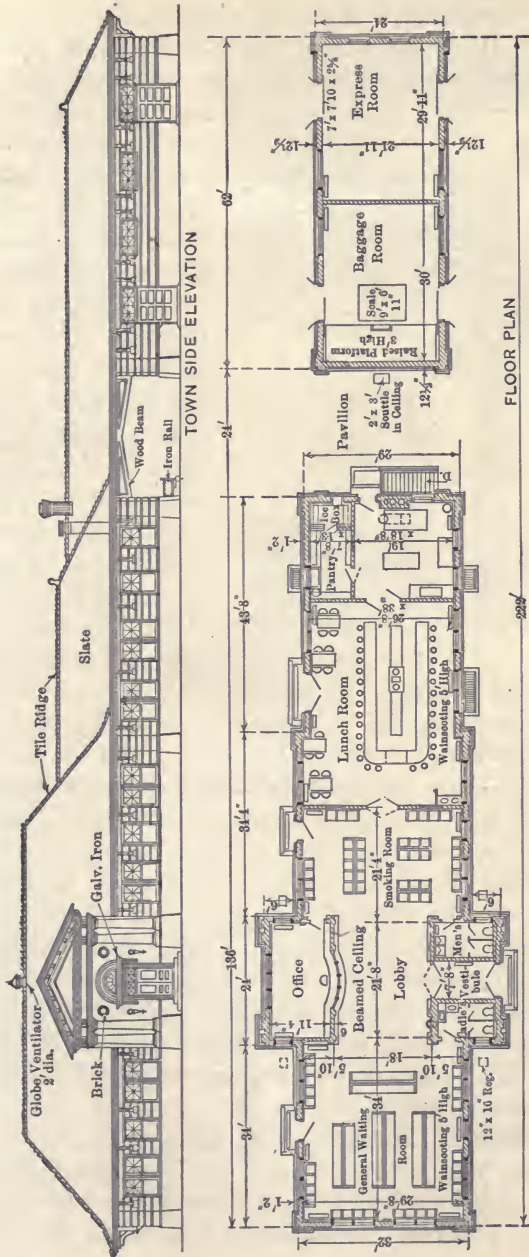
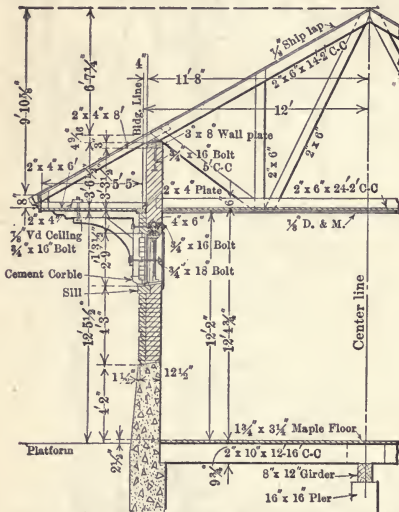

Fig. 131. Town Side Elevation and Floor Plan, Mills City Passenger Station, C. M. & P. S. Ry.

A very imposing type of station is shown, Fig. 131, built by the C. M. & P. S. Ry. at Miles City. The layout is one which commends itself as a good combination for a station of this size. A cross



SECTION THRU BAGGAGE & EXPRESS ROOMS  
Fig. 132.

section through the express and baggage room portion, is shown, Fig. 132. A station of this character with platforms will in normal times cost from \$30,000 to \$35,000.

**Log Railway Station.** — Fig. 133 illustrates a log passenger station on the Mil. & Pug. Sound Ry. The station is 64 ft. long and 38 ft. wide with public accommodation and living rooms on the ground floor, and some attic storage on the upper floor.

The structure is built of logs with the bark on and

the ends hewn tapered. At the angles the logs are notched one over the other, as shown. The logs are edged off top and bottom, to allow about 3 in. flat surface for bearing, and the joints calked with tarred oakum and plastered with ordinary mortar, nails being driven into the logs at intervals of 12 in., alternating top and bottom, in order to hold the plaster more securely. The exposed rafters shown in the general view are also small logs. The roof is of split shingles or shakes about 8" x 36", exposed 18 in. to the weather. The chimney top is of field stones. The windows have plank frames with spring catches for the sash. The interior walls are stripped and finished with V-jointed ceiling, and ornamental strapped hinges used for the doors. A station of this character will cost about \$5500, in a location where logs can be easily obtained.

**Small Fireproof Station.** (Fig. 134.) — This type of station has been built on the Wabash; the frame work is steel with "Trussit" lath attached thereto, on which is plastered a wall 3 in. thick. The roof is similar but 4 in. thick, the ceiling fol-

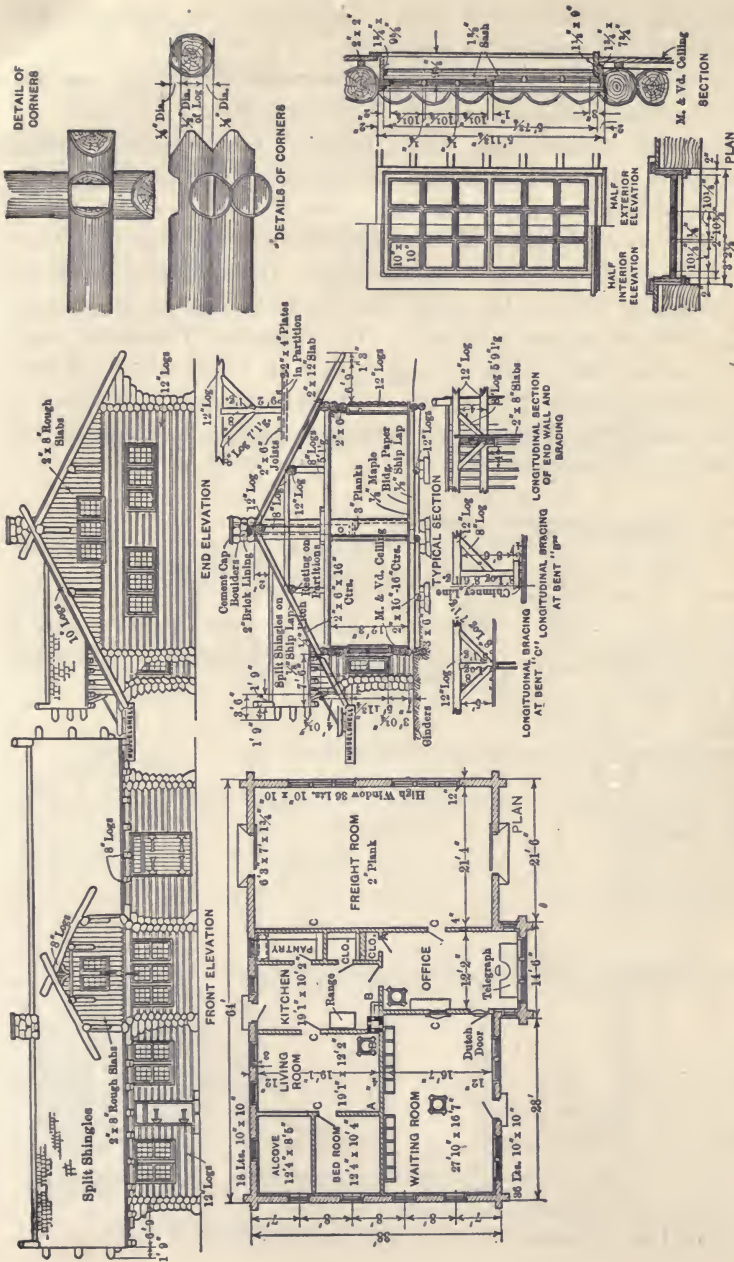

Fig. 133. Log Passenger Station.

lowing the contour of the roof. The floors and platforms are of reinforced concrete on a cinder fill.

The cost of this type of station with steel frame, etc., as described without platform would be about \$3500.

The same design with wood framing has expanded metal attached to  $\frac{1}{2}$ -inch round iron bars secured to the studs both inside and out and plastered, the outer wall being  $1\frac{1}{2}$  in. thick, plastered on both sides of the expanded metal, and the inner wall 1 in. thick, plastered on one side. The ceiling is attached to the under side of the roof purlins, thus leaving no vacant space between ceiling and roof. The chimney is made of concrete, with either a stove pipe lining or a tile flue. Where the chimney passes through the roof there is a concrete slab.

The cost of the wood frame station including wood floors but no platform is about \$2500.

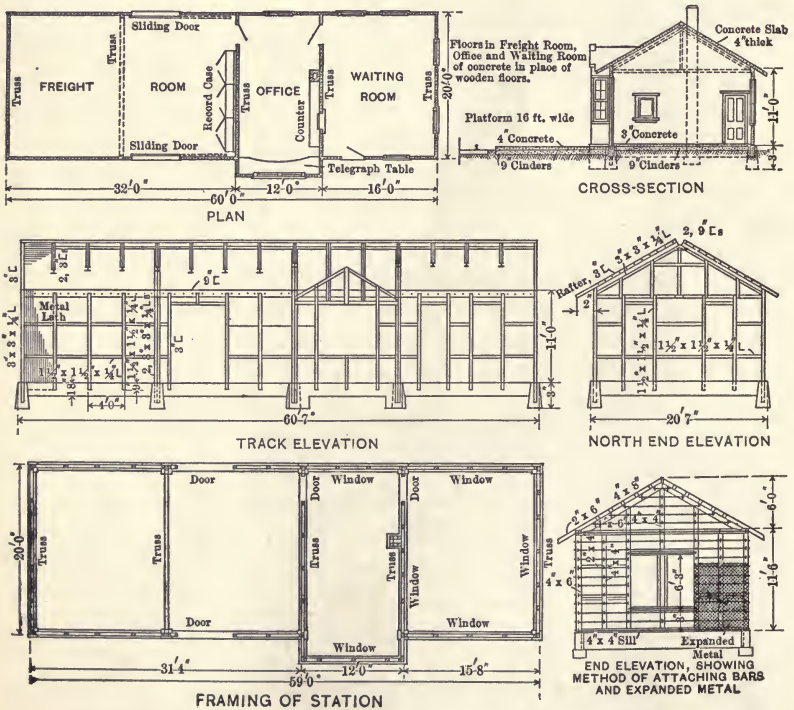

Fig. 134. "Wabash" Fireproof Station with Wooden Framework.

Frame Stations. — The following frame stations range in price from \$1000 to \$3500, which is about the average run of ordinary way stations. They are not submitted as ideal schemes, but simply as suggestions as to size and cost in a general way, that may be varied as desired.

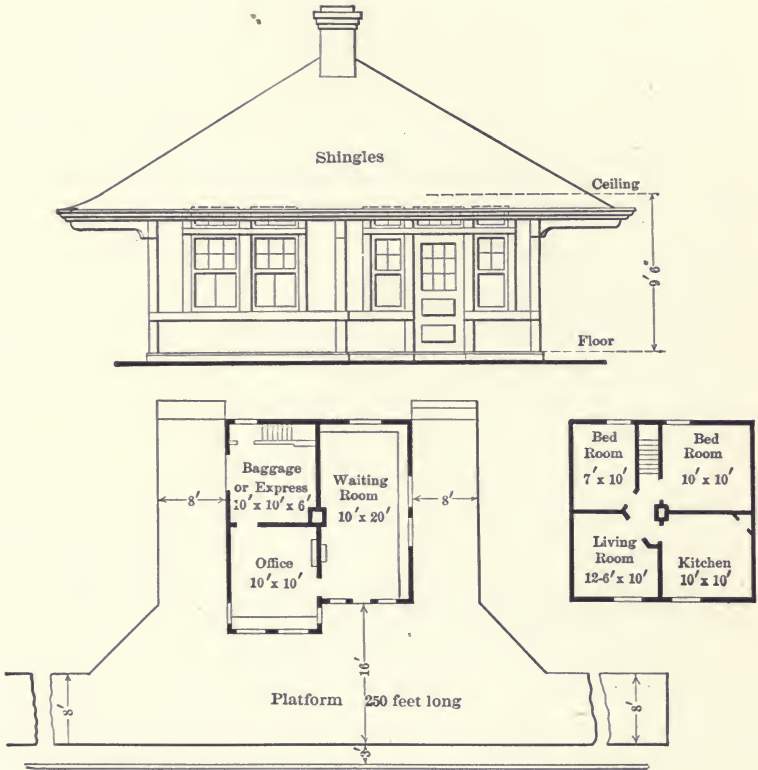

Fig. 135.

Fig. 135, station with waiting room 10' x 20', office 10' x 10', and baggage or express room 10' x 10½'. Height from floor to ceiling 9½ ft.

Approximate cost with platform complete:

Cedar posts or mud sill foundation.....	\$1000 to \$1300
Masonry foundation with cellar.....	1250 to 1500



Figs. 135 and 136, station similar to the above, with agent's dwelling over.

*Approximate cost with platform complete:*

Cedar post or mud sill foundation.....	\$1500 to \$1700
Masonry foundation with cellar.....	1800 to 2000

Fig. 137 station similar to Fig. 135, with a freight room added.

*Approximate cost with platform complete:*

Cedar post or mud sill foundation.....	\$1400 to \$1700
Masonry foundation with cellar.....	1700 to 1900

Fig. 138, station with waiting room 16' x 16', ladies' waiting room 10' x 20', office 12' x 10', baggage and express 16' x 16',

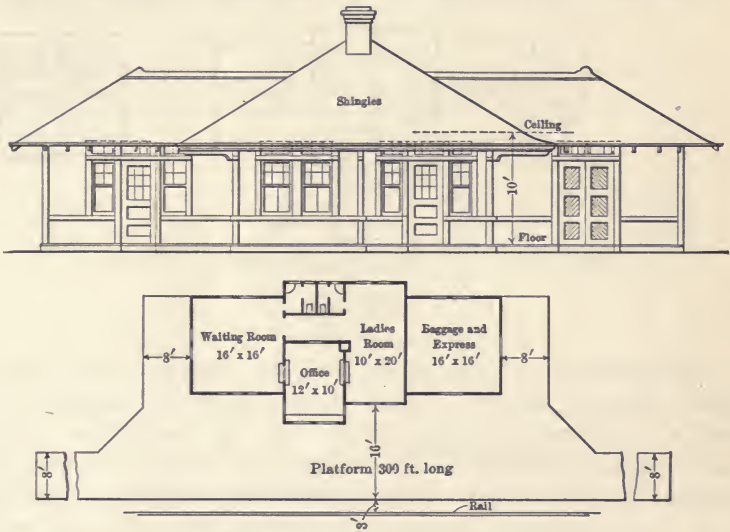

Fig. 138.

with corridor between general and ladies' waiting room, and lavatory accommodation in the rear.

*Approximate cost with platform complete:*

Cedar post or mud sill foundation.....	\$2000 to \$2500
Masonry foundation with cellar.....	2400 to 2600

Fig. 139, station with waiting room 16' x 16', ladies' room 10' x 10', office 10' x 13', baggage or freight 16' x 16', with kitchen and living rooms in the rear and four bedrooms above.

*Approximate cost with platform complete:*

Cedar post or mud sill foundation.....	\$3000 to \$3500
Masonry foundation with cellar.....	4000 to 4500

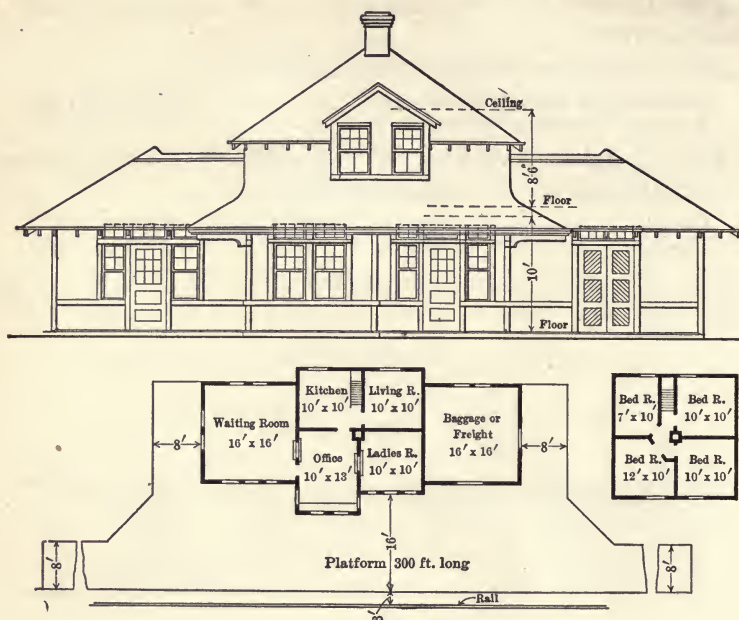

Fig. 139.

*Construction.* — Cedar sills, post or masonry foundation, brick chimneys, 2" × 4" studs 16-in. centers for outside walls, and 2" × 3" studs at 16-in. centers for inside partitions. Ceiling joists and roof rafters 2" × 8" at 2-ft. centers, well tied and secured to wall plates. Outside walls and roof to be covered with  $\frac{7}{8}$ -in. T. and G. boards and finished with ship lap, clapboards or shingles, with building paper between.

All inside walls and ceilings lath and plastered, and rooms finished with baseboard and picture mould, with architraves, sills, thresholds, and general trim for doors, windows, and other openings. Waiting-room walls burlapped 6 ft. high, and freight and baggage rooms sheathed 8 ft. high. Ground floor laid with second quality maple, or local hardwood on  $\frac{7}{8}$ -in. T. and G. boards with building paper between, other floors  $\frac{7}{8}$ -in. T. and G. narrow boards, good native pine.

When cellars are provided the floor may be of cement or 2-in. plank on 3-in. to 6-in. flatted cedars at 4-ft. centers, em-



bedded in cinders, with coal bin and chute in approved position so that coal may be shoveled from car at level of platform and run by gravity to cellar.

Platform 3-in. plank on heavy cedar sleepers at 4-ft. centers, well bedded in good gravel or cinders.

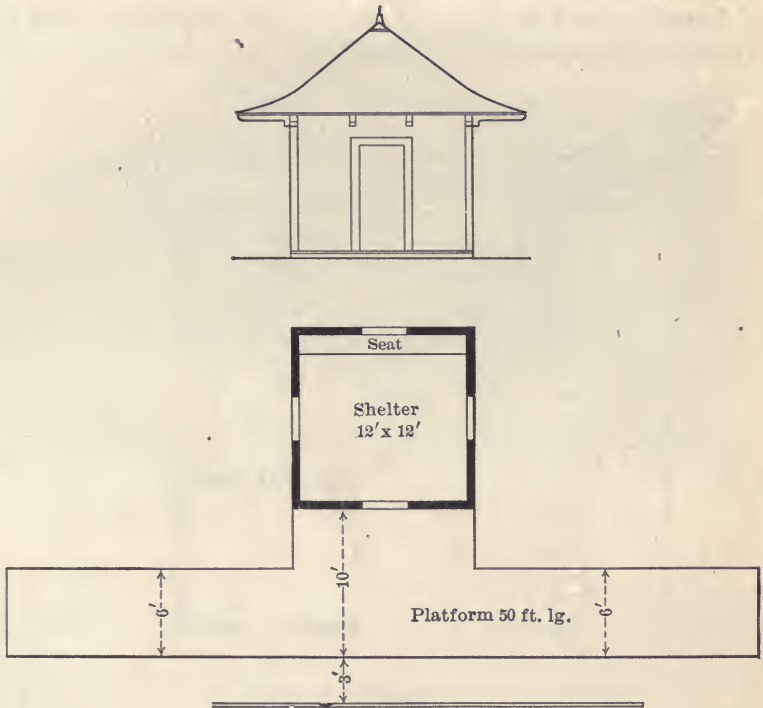

Fig. 150.

**Shelters.** — Shelters are erected at suburban points where passenger traffic is light.

*Approximate Cost.*

Fig. 150 complete with platform.....	\$125 to \$200
Fig. 151 complete with platform.....	350 to 450

*Construction.* — Foundation cedar sills, frame 2" × 3" studs, 2-ft. centers, 4" × 3" wall plates, 2" × 3" ceiling and roof joists, 2" × 6" floor joists at 2-ft. centers, covered with 1-in. rough T. and G. boards, and  $\frac{7}{8}$ -in. finished floor on top, with tar paper

between, outer frame covered with  $\frac{7}{8}$ -in. rough T. and G. boards, including roof, finished with drop siding and shingles, with tar paper between. Inside walls and ceiling sheathed with  $\frac{7}{8}$ -in. matched boards. All woodwork stained outside and inside.

Platform 5 in. above rail, made of 3-in. plank on cedar sleepers, 7-ft. centers.

Extension roof 6"  $\times$  6" posts, 4"  $\times$  4" brackets, 6"  $\times$  6" runners, rafters and roof finished similar to shelter.

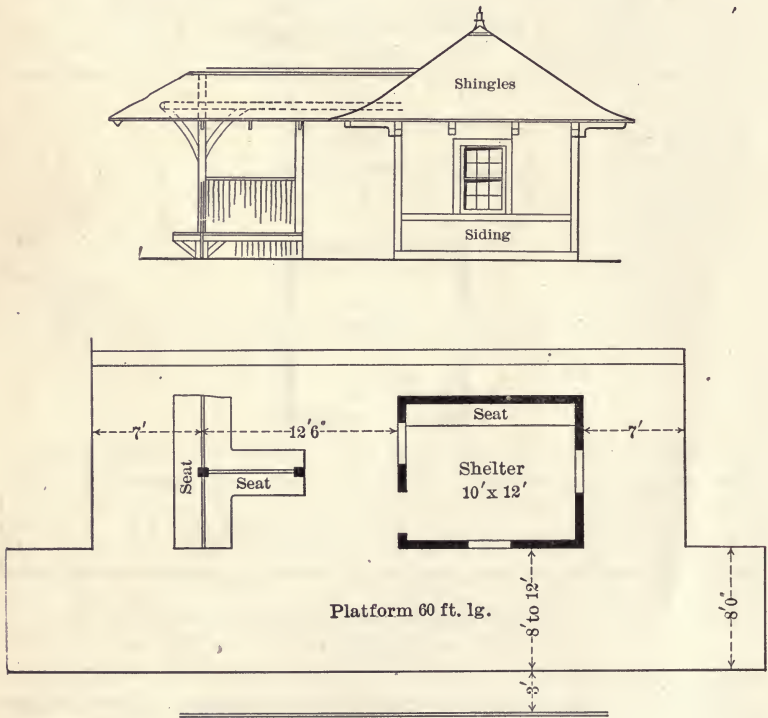

Fig. 151.

**Shelter Station, Ill. Traction System.** — The Illinois Traction System shelter station for highway crossing, known as Kerfoot station, about five miles east of Peoria, is shown in Fig. 152 (from *Ry. and Engineering Review*):

Starting from the ground, there is a concrete platform 30'  $\times$  24', the latter dimension measured at right angles to the track.

On this there is erected an enclosed waiting room of frame construction  $10' \times 12'$  in size, the latter dimension at right angles to the track, in front of which there is an open porch  $10' \times 12'$ , extending to brick columns, and over the whole there is a shingled



Fig. 152. Shelter Station, Ill. Traction System.

roof projecting out even with the concrete platform all around. The design of this roof, with its wide projection, is simple but pleasing. The door enters the enclosed waiting room from the porch, so that it is entirely protected from the weather, and the waiting room is provided with a chimney for a stove.

At points where cheaper construction is sufficient, a small shelter shed of reinforced concrete is used. This consists simply of two crossed partitions, each 8 ft. long, the ground plan of which is X-shaped, resting upon a concrete platform  $12' \times 13\frac{1}{2}'$  in size. These crossed partitions, which are of metal lath and plaster construction, are surmounted by a flat roof 7 ft. 9 in. sq., draining to a 4-in. sewer tile at the center. By this arrangement falling water does not drip from the eaves on waiting passengers.

The approximate cost of the shelter illustrated, including platform, is estimated at \$550.

Station Electric Light Standards.

Electric Light Standards. — Type *C* is made of iron pipe of varying thicknesses and has a goose neck top, to which the shade is attached and a cast iron base to fasten it to the platform. It is considered that the light in the standards should not be above the level of the engineer's eye when looking from a cab so that he will not be blinded; for this reason the height of the standard is limited. In addition the shades are made opaque as a further means of protection against the engineer's vision.

Types *A* and *B* are made of pressed metal and are usually of a stock pattern. They are anchored to the concrete platform with anchor bolts and openings for cut-outs are provided in the base.

The average cost of types *A*, *B* and *C* are as follows:

	Erected.
<i>A</i> Pressed steel, two lights, Fig. 152c.....	\$30
<i>B</i> Pressed steel, two lights, Fig. 152c.....	27
<i>C</i> Iron pipe, one light, Fig. 152c.....	12

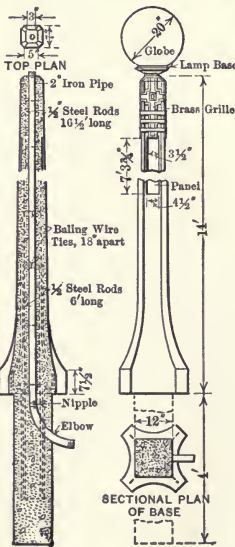

Fig. 152a. Concrete, E. L. Standard.

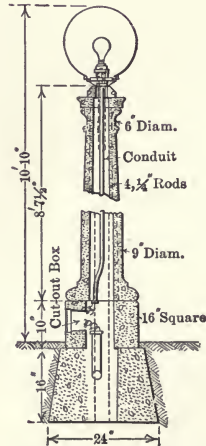

Fig. 152b. Reinforced Concrete, E. L. Standard.



the surface is quickly brushed with muriatic acid, then drenched with water and brushed over with a broom.

*Cost.* — About two gallons of acid is used for each post. Weight when finished 2000 lb. Cost of manufacture \$16 to \$19 each.

Fig. 152b is a reinforced concrete lamp-post. It is cast in three distinct parts, shaft, base and cap; when set up it is securely anchored to the concrete foundation by twisted steel reinforcing rods.

### Train Sheds.

The advent of reinforced concrete or steel encased in concrete has brought about an entire change in the design of train sheds. In place of the high one span structure which was almost universal a few years ago the low short span type of shed with posts is now most in evidence for new structures of this character.

The low shed has many advantages over the high shed, and is not only cheaper in first cost but also in maintenance. The latter item in the old type of shed was always a very heavy burden. In addition the sulphuric fumes from the locomotives was an element of danger to the steel work that had to be closely watched, and the shed itself was not altogether free from leaks and other defects that required constant attention.

The disadvantages in connection with the use of columns in the interior of a train shed, whereby the low shed is made possible, such as the danger of a fall of the roof in case of a derailment or a boiler explosion wrecking one or more columns has been largely discounted as it has been found that these possibilities are so remote as to be almost negligible. Most of the low sheds so far have been built with columns in the center of the passenger platform. It would seem, however, that there are no great objections to putting the columns between tracks, leaving the platforms clear for the convenience of passenger traffic and trucking.

Figs. 154 and 155 illustrate the two designs, one with posts in the center of platform and the other with posts between tracks from which it will be noted the design for columns between tracks increases the height of the shed so that the area of enclosed space

is somewhat greater than for the design with columns on the platform.

It is figured in the comparison that a 14-ft. platform without posts is equivalent to a 16-ft. platform with posts and that track centers would have to be about 15 ft. to take care of the posts between tracks as against 13 ft. centers without posts.

One of the very important features in connection with train shed and platform construction is the drainage and the means taken to carry the storm water from the roof, especially in cold climates where alternate freezing and thawing takes place and the outlets and downspouts are quickly clogged up with ice. All sheds, wherever possible, should be built with a continuous slight down grade, away from the concourse or midway. Square downspouts are commonly used of large dimensions run wherever possible in straight lines without bends. When a change of direction is necessary, cast iron or concrete boxes should be built, into which the downspouts should connect, the box being connected independently to the main drain; these boxes are usually built at the junctions of downspouts and the cross drains, and serve as manholes and inspection chambers. A line of steam pipes is sometimes run alongside each downspout connecting with a main through which exhaust steam can be conveyed at certain periods so as to keep the downspouts clear of ice.

**C. & N. W. Ry. Train Shed.** — The shed is of the Bush type 320 ft. wide, varying in length from 740 to 940 ft. Single row of columns are placed in the center of each platform spaced 25 ft. 6 in. center to center longitudinally and 38 ft. 9 in. transversely. The main cross roof supports are curved plate girders supported on columns consisting of two 12-in. channels connected with lacing bars. The columns are braced longitudinally by struts composed of two 10-in. channels with a half-inch bottom plate 18 in. wide. The smoke ducts are lattice girders encased in concrete and the roof framing consists of eye beam rafters and bulb angle purlins upon which is a 2½-in. concrete roofslab reinforced with wire mesh, and covered with composition roofing.

In each bay there are 5 ft. wide wire glass skylights over the platforms, and a central row of ventilators. The smoke duct

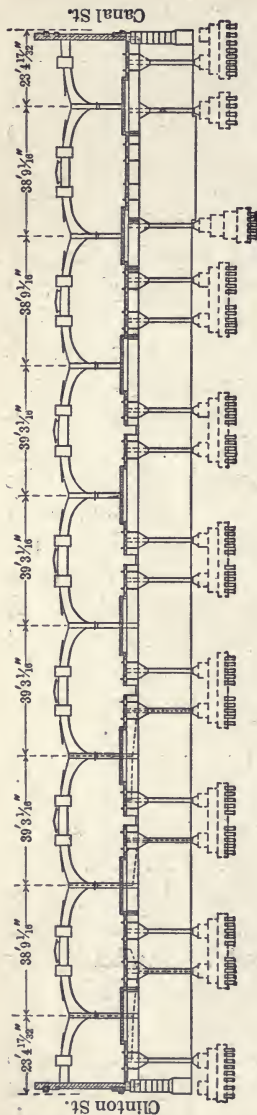

Fig. 153. Bush Train Shed, Chicago & Northwestern Railway, Chicago.

projects far enough above the roof to take care of roof drainage and is supposed to be far enough below to prevent rain and snow from reaching the platform. The roof drainage is led to gutters in the valleys and thence by downspouts at alternate columns to the sewer connections. A snow load of 20 lb. per square foot was assumed for the roof loading.

**Platform and Train Shed Floor.** — The train shed floor is carried by steel girders and columns resting on concrete piers and footings with pile clusters and has a solid floor of concrete resting upon shelf angles on the girders and track stringers well drained and waterproofed. To avoid vibration the floor was made 16 in. thick and for the platforms about 6 in. thick. In each case there is a 2-in. surface of mastic asphalt upon the concrete with a layer of burlap in the asphalt. The platforms are 16 ft. wide and 8 in. above top of rail.

**Lehigh Valley Train Shed.** — A shed with posts between tracks of the Bush type was built recently at the old Lehigh Valley depot at Buffalo as it was found to be more suitable for existing conditions than a shed with posts in the center of platform. (Fig. 155.)

The columns between tracks have a clearance of 14 ft. and are built 14 ft. 8-in. centers, the width of column being 8 in. The platforms are 5 ft. from center of track and about 14 ft. 3 in. wide, and 6½ in. above top of rail.



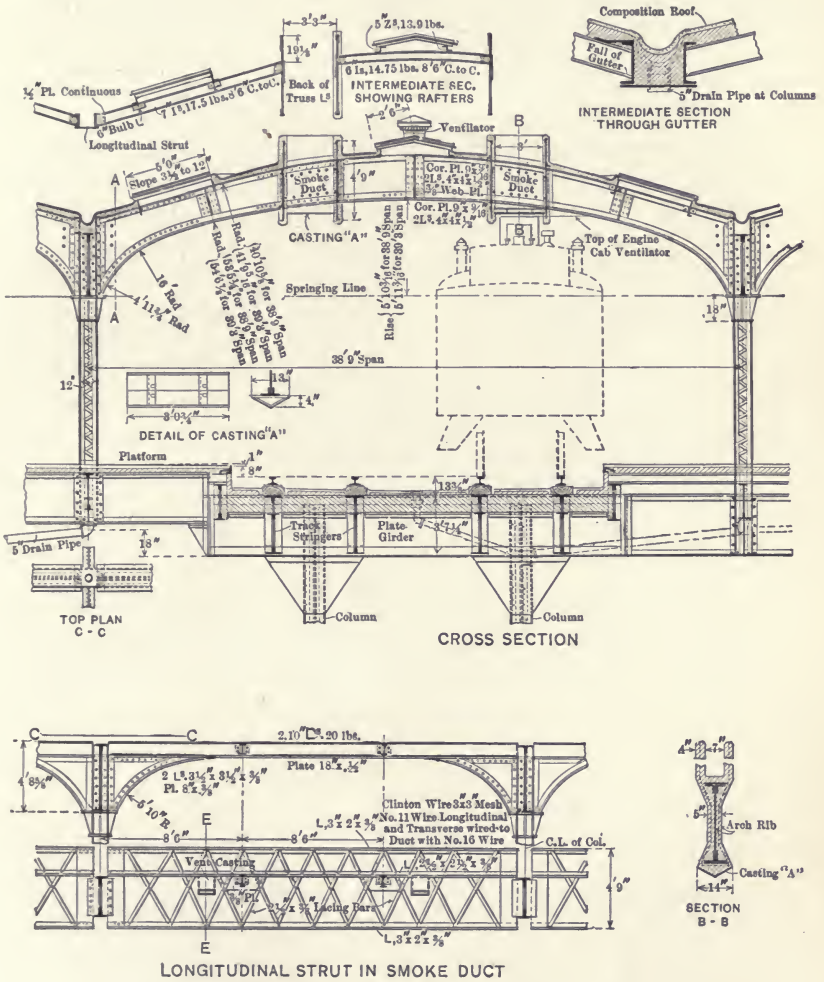

Fig. 154. Details of Train Shed, C. & N. W. Ry.

The columns are spaced 33 ft. centers longitudinally and are built of sections with the web parallel to the track. Curved plate girders constitute the main truss supports with lattice steel trusses forming the longitudinal purlins, those acting as the smoke ducts being encased in concrete; the roof covering is of concrete slab construction finished on top with composition roofing.

The platforms are built of concrete on cinder fill as shown, Fig. 156. The sidewalks are 8 in. thick, 14 ft. wide; the platform slab is 6 in. at the outer edge and 7½ in. at the center and has a reinforcement of triangular wire mesh. Beneath the platform and between walls a bed of 6 in. tamped cinders is placed before laying the concrete.

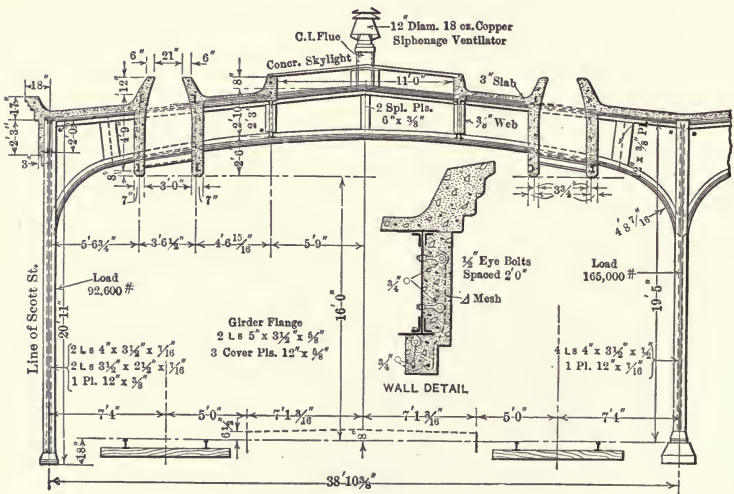

Fig. 155. Cross-section of Typical Bay — Eye Bolts Used in Wall Detail.  
L. V. Train Shed at Buffalo.

A detail of the Kepplar roof lights used on this shed is shown, Fig. 156, and is built of 6 in. units with steel reinforced cement ribs.



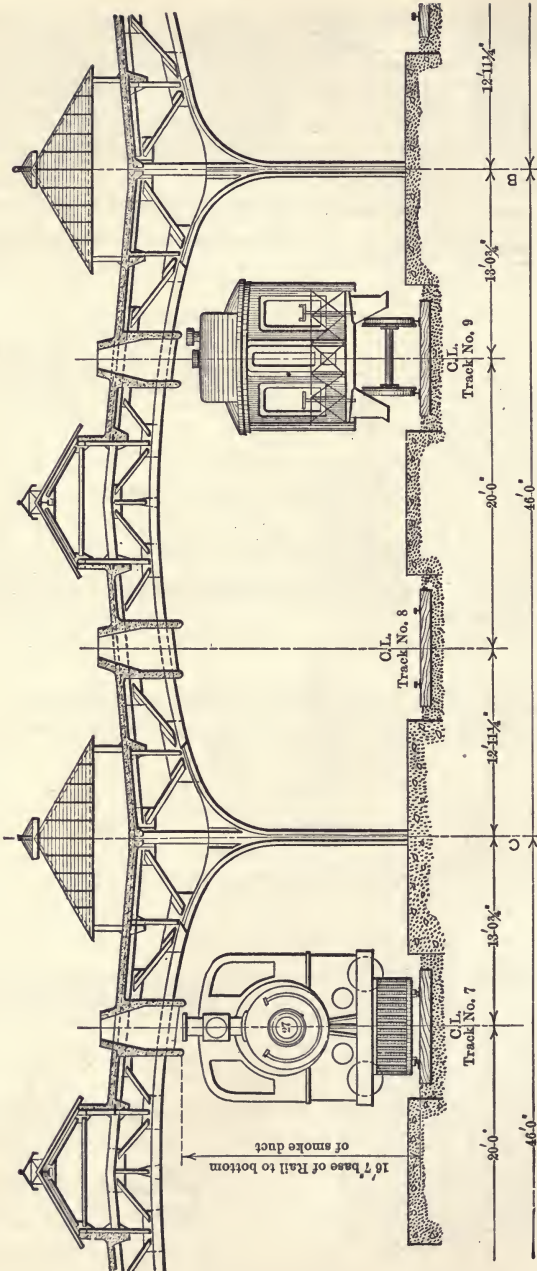

Fig. 157. C. P. R. Train Shed, Windsor Street, Montreal.

**C. P. R. Train Shed.** — The train shed recently built at Montreal, P. Q., is of the Bush type, the layout comprising separate passenger and trucking platforms. The columns are placed alongside the center of each passenger platform and are 46 ft. centers crosswise and 28 ft. centers longitudinally. The main cross roof supports are curved trusses, which support the longitudinal steel purlins and lattice trusses forming the smoke ducts, the latter being encased in concrete. The roof covering is of concrete slab construction reinforced with wire mesh and finished on top with asbestos roofing composition. (Fig. 157.)

The skylights rise above the main roof and are very pronounced and give a very much larger amount of light and ventilation than is usual in this type of shed and while it may have some advantage in this respect over the flat style of skylights, the latter has certainly a more simplified appearance and will not hold drifting snow to the same extent as the former. The fact that the smoke ducts are open all the way throughout the length of the shed is more than sufficient for all the ventilation necessary and the less projections on a roof the easier it will be wind swept and kept clear of snow.

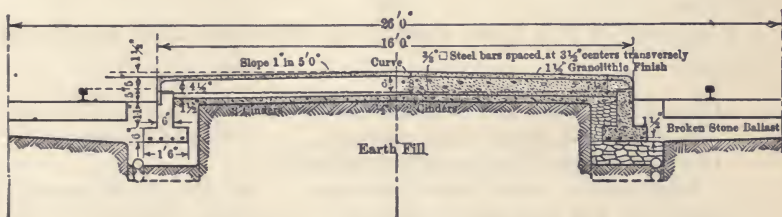

Fig. 158. C. P. R. Passenger Platform.

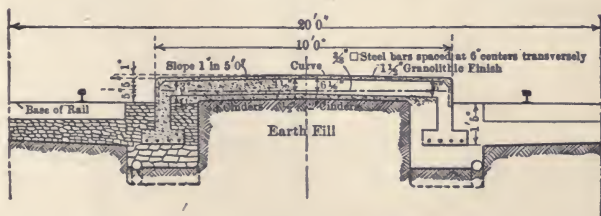

Fig. 159. C. P. R. Baggage Platform.

**Platforms.** — The passenger platforms are 16 ft. wide and the trucking platforms 10 ft. Their construction is shown in Figs. 158 and 159. The side walls are 6 in. thick with a footing course resting on a broken stone fill. The platforms are  $6\frac{1}{2}$  in. thick and reinforced with  $\frac{3}{4}$ -in. square steel bars at about 15 in. centers; most of the filling under the platforms was of broken stone. Farm drains of 4 in. tile were laid lengthwise about 2 ft. 3 in. below the track, connecting with the cross drains at every alternate column, the latter being 6 in. cast iron pipe carried under the tracks crosswise and connected to the main sewer.

An improvement to this design would be to let the platform portion project over the wall on each side so as to cast a shadow which would give a better appearance and make a better drip for waste water, etc., when washing or cleaning platforms.

**Cost of Train Sheds.** — The range of prices for train shed work is bound to be very variable depending upon the kind of shed, the loading figured, its height, width and the amount and kind of light and ventilation desired. The nearest method for different designs is to take the cubic contents and compare the prices per cubic foot of enclosed space, rather than the cost per square foot.

For sheds of the types shown, the following units may be of service:

Cost of train shed (not including platforms, foundations or drains below platforms) . . . .	6 to 10 cents per cu. ft.
Cost of train shed (not including platforms, foundations or drains below platforms) . . . .	\$1.10 to \$2.25 per sq. ft.
Pounds of steel per square foot of roof . . . . .	16 lb. to 20 lb.
The cost of reinforced platforms including the excavation and stone filling under, as well as the curbing, Figs. 158 and 159, average per square foot . . . . .	40 to 60¢

**Station Platform Canopies.** — The inverted type of station canopies shown in Figs. 160 and 161 illustrates the designs on the N. Y. C. The roof is supported by one row of posts down the center of the platform and drains to the center, the water being carried off by downspouts inside the posts.

Fig. 161 is for platforms used exclusively for passenger business and Fig. 160 is for platforms used both for freight and passenger. In the former case the butterfly extension covers the platform to a greater extent than the latter, as is shown by the clearances. The posts are made of four light angles or two channels, placed back to back, with steel brackets and purlins, the roof boards being nailed to nailing strips secured to the tops of the beams and covered with composition roofing.

The cost of this type of platform roof may be estimated at \$1.25 per square foot, which includes the ordinary foundation for the posts 5 ft. below ground, but does not include any platform or drainage below and beyond the platforms.

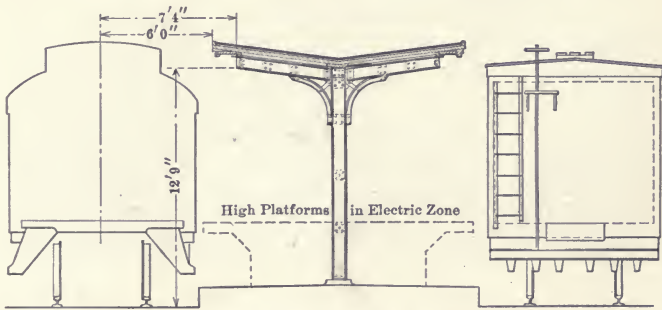

Fig. 160. N. Y. C. Butterfly Platform Shed, Passenger and Freight Traffic.

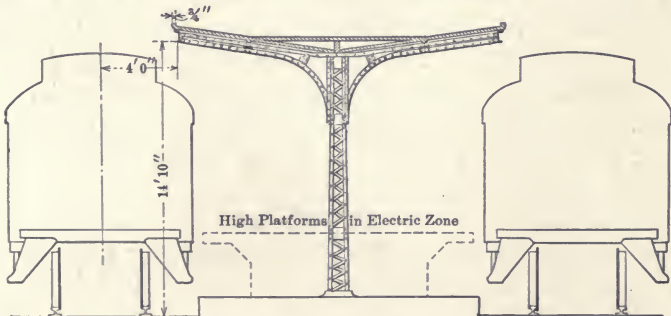

Fig. 161. N. Y. C. Butterfly Platform Shed, Passenger Traffic Only.

**Platform Shelters, Southern Pacific Co.** — The new station of the Southern Pacific Co. at Los Angeles, Cal., has the platforms covered by shelter roofs built of reinforced-concrete units. The roofs are of the "butterfly" or concave type, sloping down from the eaves to a central gutter. There are four platforms 740 ft. long and 16 ft. wide, with roofs 18 ft. wide.

The main construction consists of a central row of T-head columns, spaced 20 ft. center to center and carrying two rows of roof slabs 20 ft. long. (Fig. 161a.) The columns are 12"  $\times$  24" at the base and 12"  $\times$  18" at the top, with caps or heads 10 ft. long and 17 in. deep. On each side of the cap is a recess, forming a shelf for the end of the roof slab.

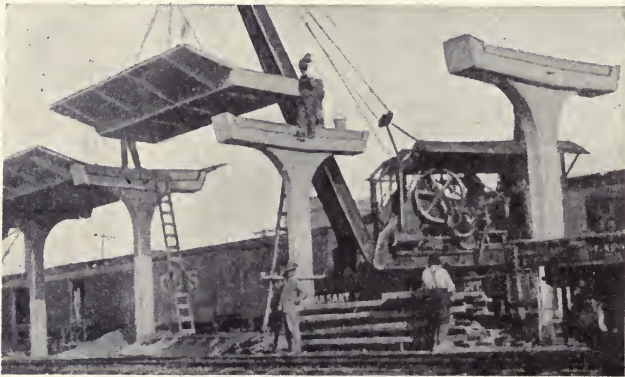

Fig. 161a. Placing Roof Slabs.

Reinforcing bars projecting from the ends of the slabs lap each other over the top of the cap and are embedded in cement mortar, which is filled in over the cap to the level of the slabs. The longitudinal joint between the slabs is also filled with cement mortar. A roofing composition is laid upon the completed shelter. At intervals of about 340 ft. an expansion joint is provided, covered with copper flashing.

The roof slab has a minimum thickness of 4 in. (increased to give an incline for drainage) and is stiffened by six transverse ribs. The columns are set in sockets, 18 in. deep, in pedestal footings.



A variation in this construction is required where the inclined ramps connect the platforms with the subway beneath the tracks. Here the roof is carried by two-column bents, as shown in Fig. 161b. These columns are 8" x 12", connected by an arched cap. They are set in steel sockets in the steel framing of the subway roof. *Engineering News*, July 13, 1916.

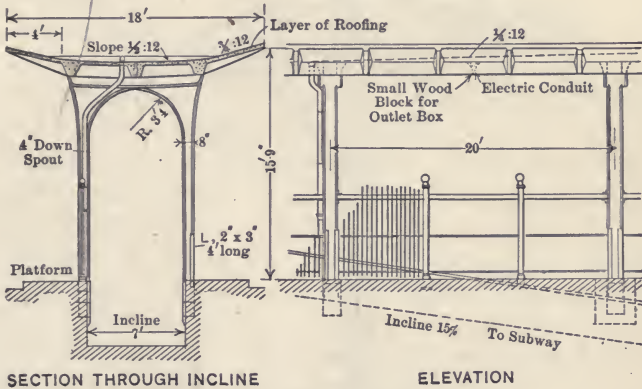

Fig. 161b. Concrete Platform Shelter with Two-Post Bents Spanning Incline Approach.

**C. P. R. Platform Shelter.** (Fig. 162.) — Umbrella type of platform shelter 16 ft. wide, with main posts 8" x 10" — 14-ft. centers, ridge plate 11" x 3", rafters and ties 2" x 6" with 4" x 6" supports, and 4" x 6" run beams, roof covered with 1 1/8-in. matched boarding, and galvanized iron, ready roofing or shingles on top; the main posts are supported on round, flatted cedar sills about 6 ft. below the platform, braced both sides, and held laterally by the platform joists. The platform is made of 3-in. plank on top of 11" x 3" joists on split cedar sills at about 7-ft. centers.

Estimated cost per square foot of covered space without platform, 30 cents; with platform, 55 cents; does not include any piping or drainage.

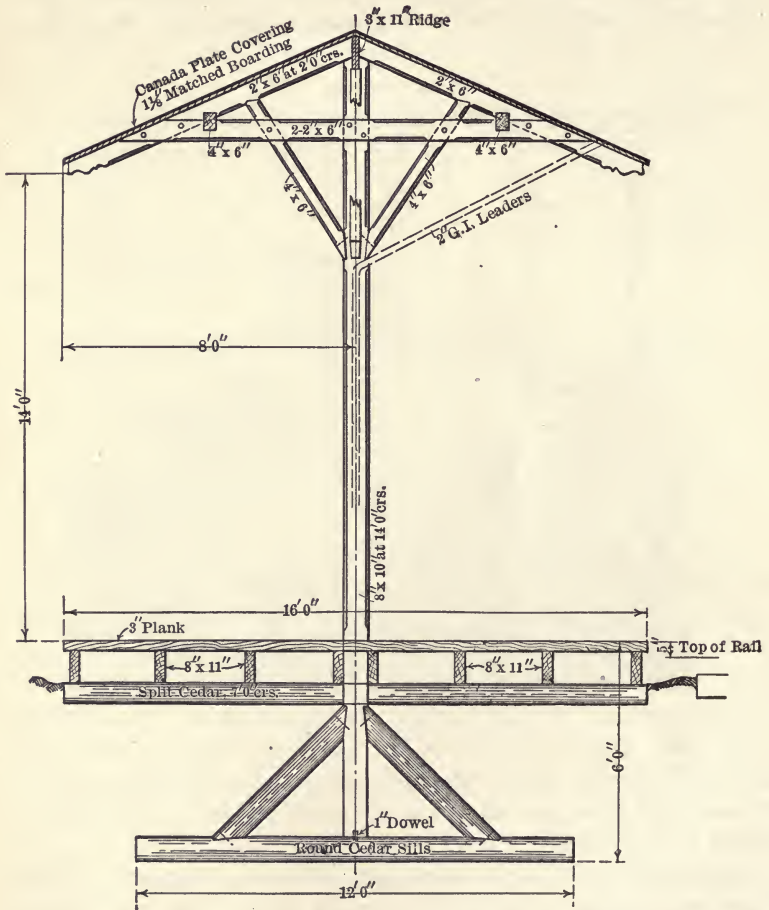
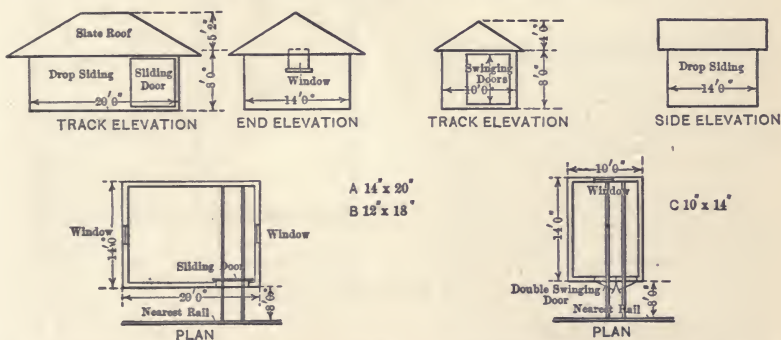

Fig. 162. C. P. R. Wood Umbrella Platform Shelter.

CHAPTER XVII.

ROADWAY BUILDINGS.

**Tool Houses.**— In the maintenance of track the road is divided into sections ranging from 4 to 8 miles or thereabout, each section being looked after by a gang of men under a foreman who is responsible for its safety to the roadmaster. A tool house to hold the hand car and tools is usually provided for each section, and is generally located on the right of way close to a public road, or near a station, and within easy reach of the section foreman's house; it is set back far enough so that the hand car can be pulled out to stand clear of the tool-house door when open, and passing trains, placed when possible alongside the main track clear of switches. The minimum distance from rail and the sizes of the houses recommended by the Amer. Ry. Eng. Assoc. are shown on the following sketches.



Recommended A. R. E. Assoc. Typical Section Tool House, Classes A. and B.

Recommended A. R. E. Assoc. Typical Section Tool House, Class C.

Approximate costs:

Tool house A, 14' x 20', about \$200.

Tool house B, 12' x 18', about \$150.

Tool house C, 10' x 14', about \$100.

The C. P. R. Standard single and double tool houses are illustrated, pages 340 and 341, and may briefly be described as follows:

Plank or cedar sill foundation for flat ground, and cedar posts 6-in. diameter about 5-ft. centers, or old bridge stringers, when on sloping ground.

Sill 4" × 4" all round the outer walls, joists 4" × 6" at 2-ft. centers, covered with 2-in. plank.

2-in. by 4-in. studs, 2-ft. centers doubled at door openings and all corners, 4" × 4" wall plates 7 ft. high from floor, outside boarded with  $\frac{7}{8}$ -in. rough plank finished with seven-eighths ship lap or drop siding with 1" × 5" planed, top, bottom and corner boards.

Rafters, 2-in. by 4-in., 2-ft. centers, one-third pitch roof covered with  $\frac{7}{8}$ -in. rough boards and shingles with building paper between, gable ends.

A small window is provided at each end, a double door facing the track, opening outwards, about 7 ft. wide, with stringers and light platform from the house to the track, for convenience in taking the hand car out and in. The door is provided with chain staple and switch padlock.

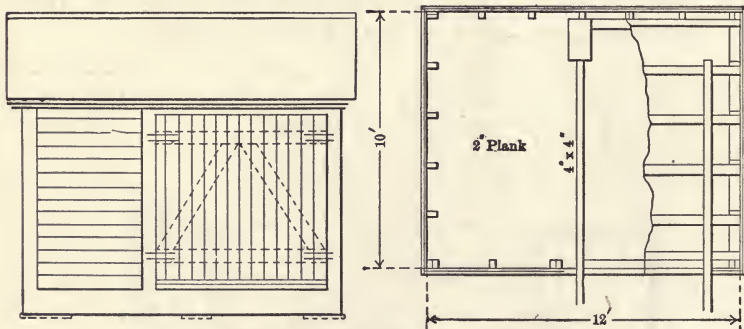

Fig. 163. C. P. R. Single Tool House.

*Approximate estimate of cost.*

SINGLE TOOL HOUSE. (Fig. 163.)

Quantities.	Material.	Labor.	Total unit.	Cost.
2000 ft. B. M. lumber per thousand				
ft. B. M. ....	\$17.00	\$13.00	\$30.00	\$60.00
2000 shingles per thousand .....	2.00	2.00	4.00	8.00
Hardware and glass .....	3.00	2.00	.....	5.00
Painting .....	5.00	7.00	.....	12.00
Total .....	.....	.....	.....	\$85.00

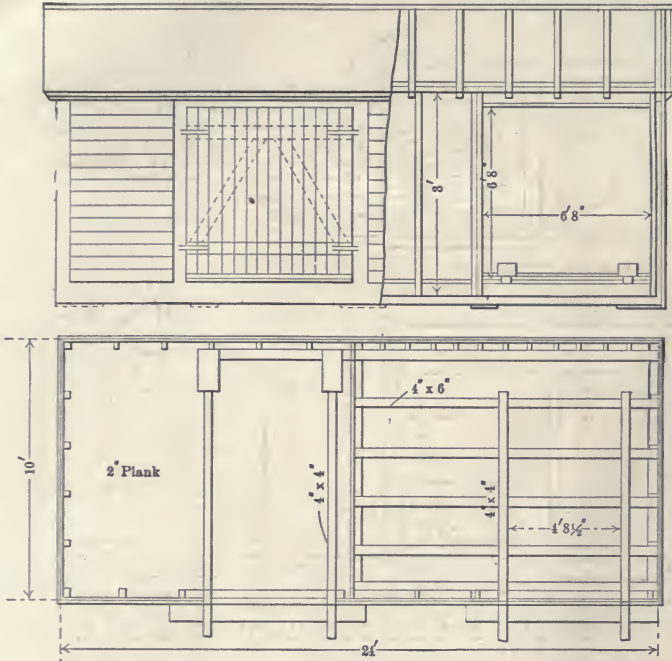

Fig. 164. C. P. R. Double Tool House.

*Approximate estimate of cost.*

Quantities.	Material.	Labor.	Total unit.	Cost.
3500 ft. B. M. lumber per thousand				
ft. B. M. ....	\$17.00	\$13.00	\$30.00	\$105.00
4000 shingles per thousand.....	2.00	2.00	4.00	16.00
Hardware and glass.....	6.00	4.00	.....	10.00
Painting.....	9.00	12.00	.....	21.00
Total.....	.....	.....	.....	\$152.00

The B. & O. section tool houses, Figs. 165 and 166, present a very neat appearance and are simple in design.

The size of the No. 1 house is 10' x 14', the framing is 2" x 6" studs doubled at the corners; the building is sheathed on the outside with drop siding. The cost is approximately estimated at \$115 complete in place.

The No. 2 house is similar to No. 1 but is only 8' x 10' and the cost is estimated at \$75 complete in place.

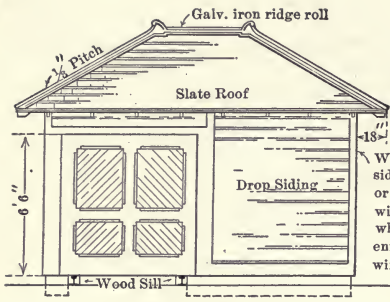

Note: Window in this end only. Window to be made to slide to one side on the inside. A closed shutter or door to be made to follow the window to close up the opening when window is drawn back. Fastenings to be made to lock both window and shutter securely.

FRONT ELEVATION

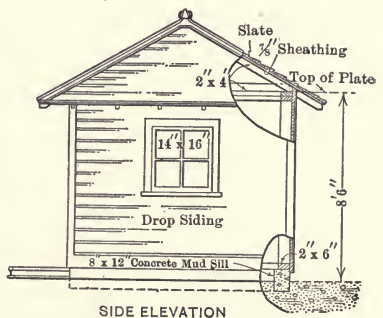
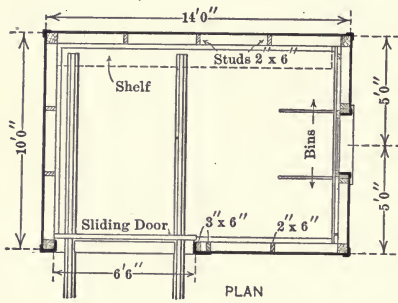

SIDE ELEVATION

Fig. 165. B. & O. R. R. Section Tool House No. 1.

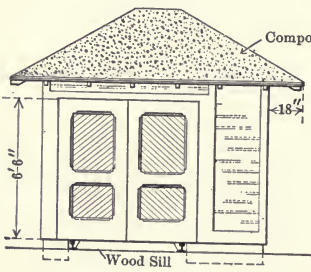

FRONT ELEVATION

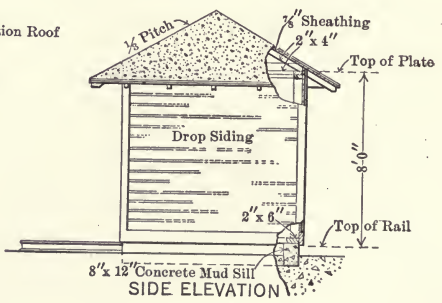

SIDE ELEVATION

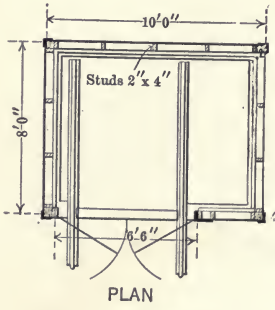

PLAN

Fig. 166. B. & O. R. R. Section Tool House No. 2.

**Section Houses.** — Section houses are built along the right of way principally for the convenience of having the trackmen live close at hand to readily respond for emergency service at any time. The houses are usually framed structures, and are built single or double; the double houses are convenient at points where it is necessary to keep two gangs.

The character of these houses varies to suit the class of labor and the accommodation necessary or desirable to provide under different conditions. An ordinary single section house, Fig. 167, can be built for \$750, wood foundation, or \$900 with concrete

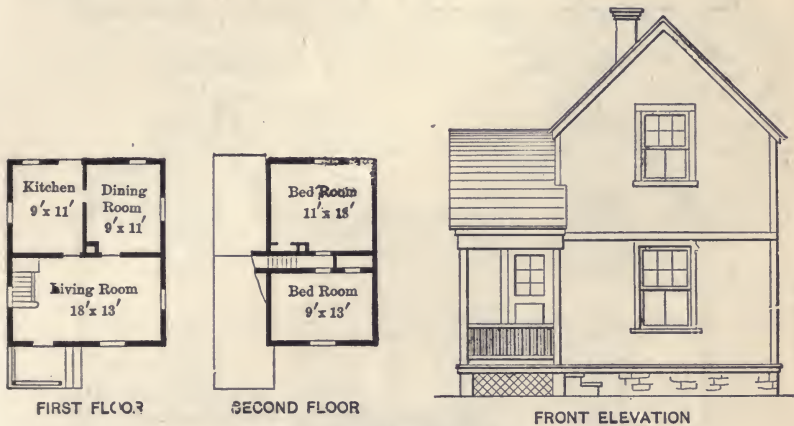

Fig. 167. Single Section House.

foundation. A double house, Fig. 168, is estimated at \$1400 with wood foundation or \$1700 for concrete foundation. Their construction would be about as follows:

*Construction.* — Frame and partitions, spruce; rough boarding, floors, clapboards, outside and inside finish, frames, etc., good quality native spruce or pine; shingles, pines or cedar; all mouldings, doors, windows, and inside finish, stock pattern.

Cedar sills or posts about 5-ft. centers, or when it can be done cheaply, concrete, stone, or brick foundation with cellar. Frame, 2" x 3" studs at 16-in. centers, 2" x 10" joists at 16-in. centers, ceiling roof joists and rafters 2" x 6" at 16-in. centers, 4" x 3" wall plates and runners, outside walls  $\frac{7}{8}$ -in. rough boarding, with  $\frac{7}{8}$ -in. ship lap, siding, or shingles, with building paper between,

and 1" × 5" trim around windows, doors, porch, eaves, etc. All inside walls lathed and plastered. Shingle roof, 7/8-in. boards with building paper between. Floors 7/8-in. rough boards and 7/8-in. finished floor with building paper between for ground floor, and 7/8-in. finished floor only for upper story.

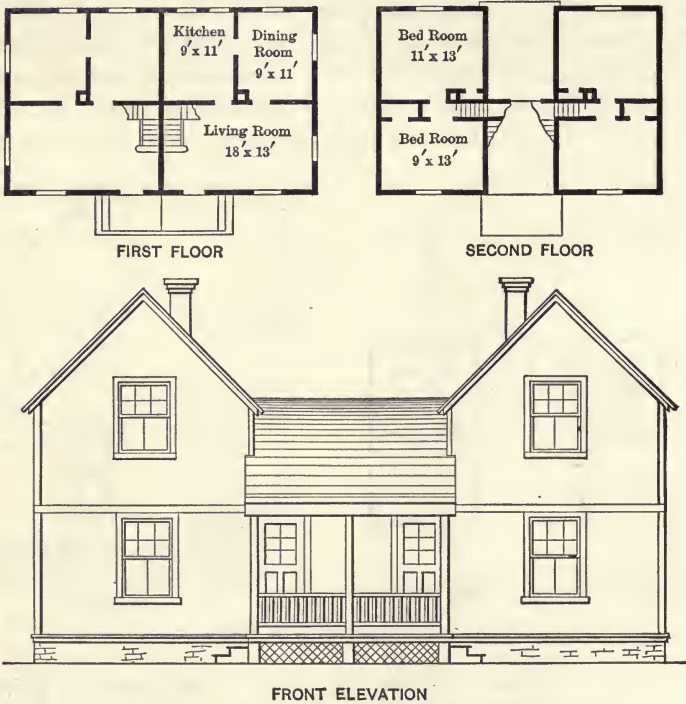

Fig. 168. Double Section House.

*Approximate estimates of cost.*

Quantities.	Single house.	Double house.
Excavation and wood foundation.....	\$20.00	\$35.00
Brick.....	35.00	70.00
Hardware.....	20.00	35.00
Carpentry.....	518.00	953.00
Lath and plaster.....	82.00	167.00
Shingles.....	25.00	45.00
Painting and glazing.....	50.00	95.00
	\$750.00	\$1400.00
If masonry foundation, add.....	150.00	300.00
Total.....	\$900.00	\$1700.00



**Combination Section House.**—A combination section house adopted by the Lehigh Valley for the use of its foremen and laborers provides a bunk room  $14' \times 30'$  in rear, with separate entrance, and house accommodation in addition, comprising a dining room and kitchen on the first floor, and three bedrooms on the second floor. (Fig. 169.)

The structure is  $1\frac{1}{2}$  stories in height, and is constructed of hollow tile building blocks, with buff colored rock asbestos stucco finish, and supported on concrete foundations. Red quarry floor tiles are used for the bunk room floor, and pine floors for the balance.

The bunk room is plastered with two coats Portland cement mortar, trowelled to a hard finish and waterproofed; the balance of the house is finished with three coats ready mixed hard wall plaster. The building is heated with stoves, and a cellar is provided for storage.

*Cost.*—The cost of this building complete is about \$3750.

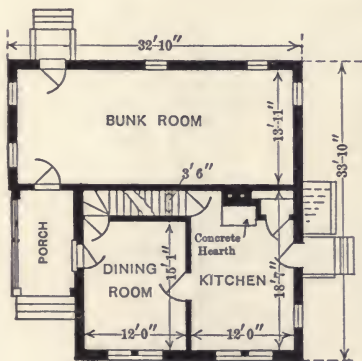

FIRST FLOOR

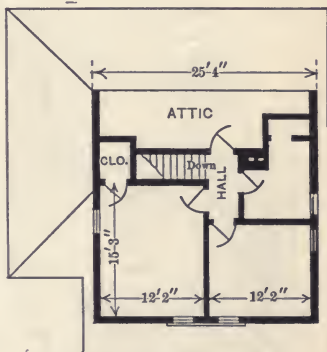

SECOND FLOOR

Fig. 169. Combination Section House.

C. P. R. Standard Section House. — The standard C. P. R. section house, Fig. 170, is a two-story frame building on a concrete foundation. It provides six fairly large rooms, three on each floor, with a partial cellar in the basement, or when desired the whole basement may be made into a cellar. The

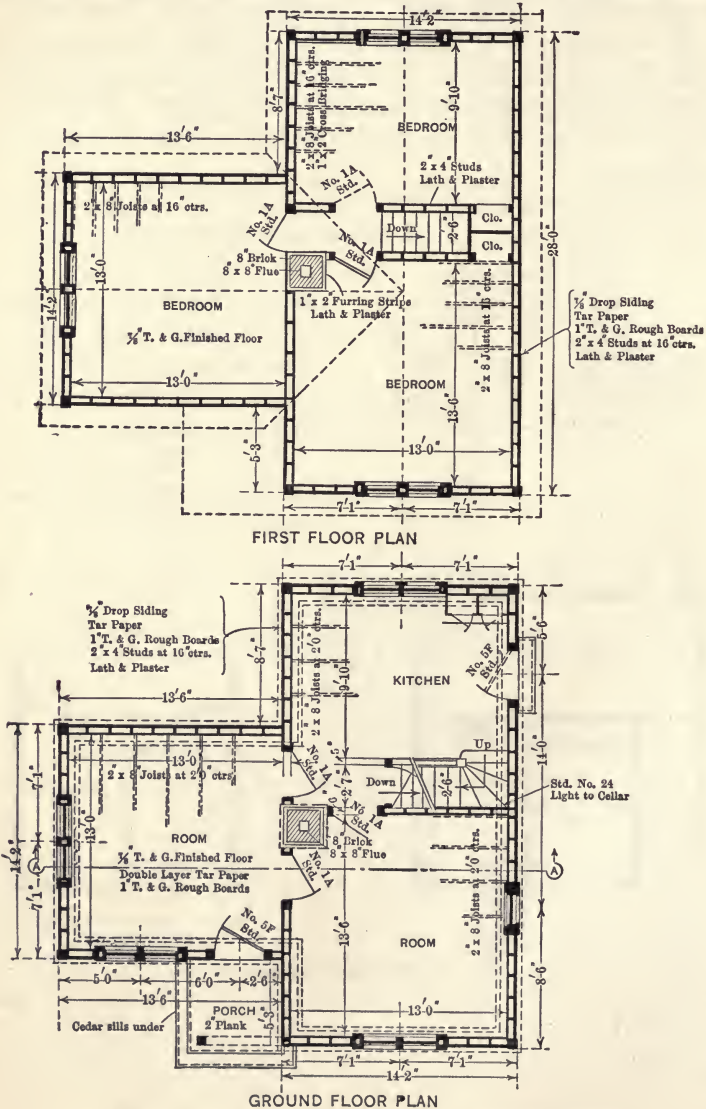
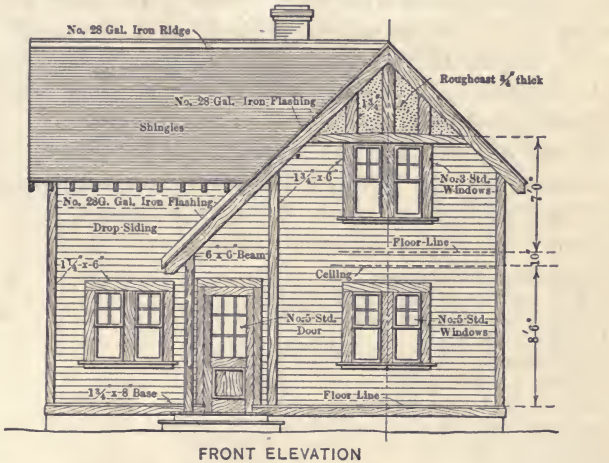

Fig. 170. C. P. R. No. 4 Standard Section House.

house is lathed and plastered inside throughout and double sheathed on the outside; the concrete walls are carried to the top of the joists at the ground floor level.

The average cost of the house complete is from \$1800 to \$2100.



FRONT ELEVATION

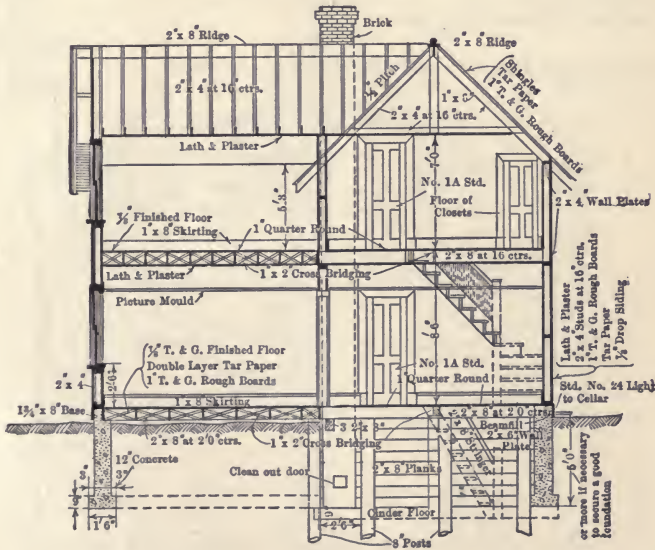

SECTION A-A

Fig. 170 (Continued). C. P. R. No. 4 Standard Section House.

**C. P. R. Double Section House.** — Fig. 171 illustrates a double section house as built on the C. P. R. The foundation may be of cedar sills or concrete with a basement. The ground and first floor, including the roof, etc., are built of timber throughout. This layout provides three rooms downstairs and three rooms upstairs with two chimneys for each house. The studding for the outer walls is 2" × 4" and the inside walls are 2" × 3", all at 16" centers. The exterior is covered with T. and G. boards with a layer of felt and finished with shingles. The interior is lathed and plastered throughout.

The cost of this structure on cedar sill foundation was \$2800, the details of which are given below. When concrete foundation is desired the cost would be about \$3500.

*Approximate cost of a double section house.*

Excavation and clearing.....	\$ 150.00
400 ft. cedar sill foundation @ 15¢.....	60.00
25,000 ft. B. M. lumber @ \$40.00.....	1000.00
Doors and windows.....	375.00
34,000 shingles @ \$5.00.....	170.00
800 yds. plaster @ 35¢.....	280.00
36 yds. rough cast @ 50¢.....	18.00
5 squares tar and gravel @ \$6.00.....	30.00
5000 brick and lime for chimney @ \$20.00.....	100.00
Hardware, etc.....	192.00
50 gallons paint @ \$2.50.....	125.00
	\$2500.00
Supervision and contingencies about 10 per cent.....	300.00
Total.....	\$2800.00

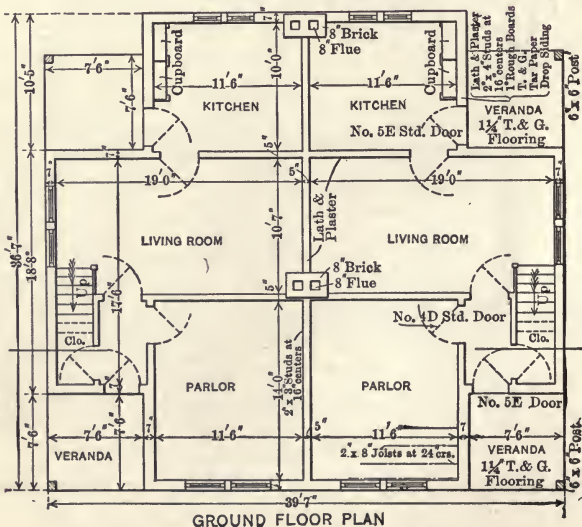
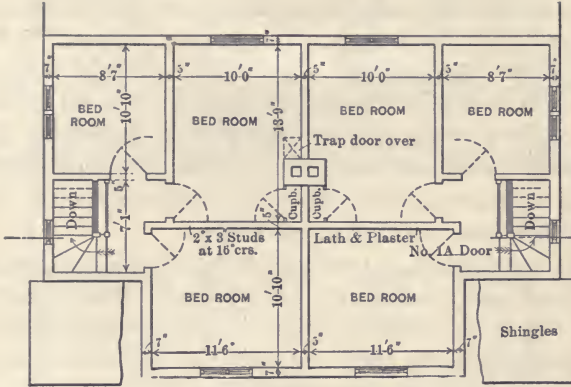
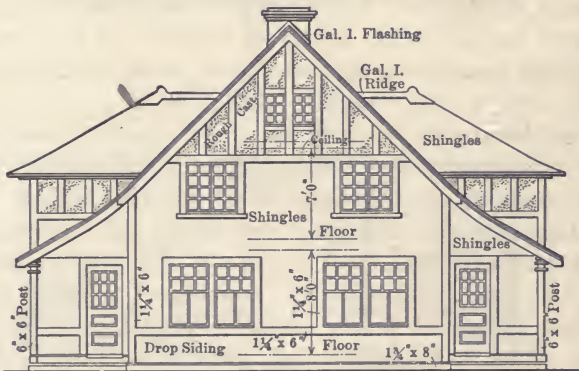

Fig. 171. C. P. R. Double Section House.



FIRST FLOOR PLAN



FRONT ELEVATION

Fig. 171 (Continued). C. P. R. Double Section House.

**Rest Houses.** — One of the important features about a rest house is to obtain a good site for it. As often as not it is located in the corner of a yard where it is subjected to noise and periodical deluges of smoke from the roundhouse which not only causes irritation and dissatisfaction, but also adds greatly to its maintenance as it requires constant painting to keep the building from looking dingy.

It is claimed that the men coming in tired at all hours do not care to walk very far and in consequence the nearer the house is to his cab or caboose at the end of his run the better he likes it. The same also applies when he is called for duty, the closer he is the less time it takes to get ready.

Whilst these have a bearing on the location, freedom from smoke and noise, attractive outlook and genial surroundings have a value in efficiency that is too often overlooked and more money is often spent in trying to counteract a poor site by providing lavish indoor attractiveness, that would otherwise not be necessary if the site had been more congenial.

These houses very often furnish room and board for office and shop hands as well as trainmen and the designs vary to suit local conditions. In the larger houses the layout is in the nature of an up-to-date hotel, with office and help accommodation, check room, safe, lockers, bunks, beds, reading and writing rooms, lecture hall, bowling alleys, billiard room, baths and showers, lavatories, as well as ample kitchen accommodation and equipment, besides store rooms, ice and refrigeration, heat, fire protection, electric light, attractive furnishings, provision for future extension and good ventilation and sanitation.

The Railway Branch of Y. M. C. A., working in conjunction with the railroads, has established a great number of boarding houses or hotels at many of the principal divisional points, which prior to their advent did not provide the proper class of accommodation for railway men. It is claimed by many, however, that as good results could be obtained by company operation, under the Sleeping and Dining Car Department.

**Two Story Rest House.** — A two story type of rest house to accommodate fifty men is shown in Fig. 172. In place of the usual dining and reading room, a large lounge room is provided

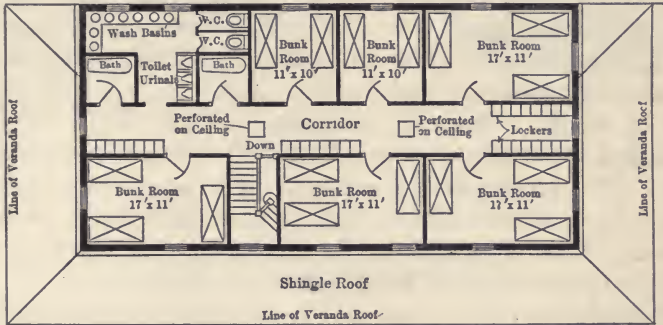
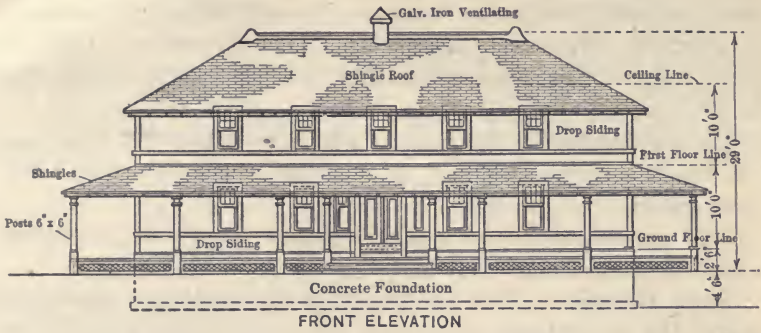

FIRST FLOOR PLAN

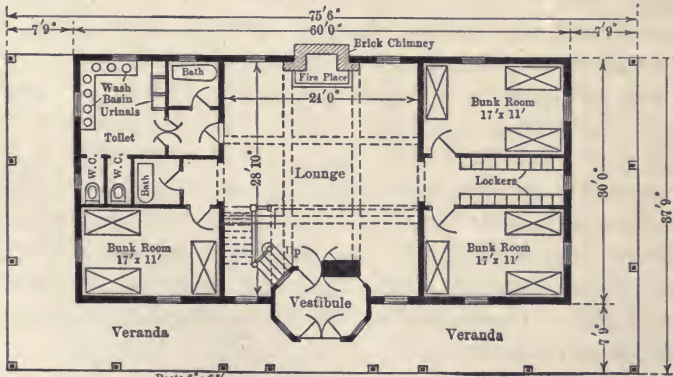

GROUND FLOOR PLAN

Fig. 172. Two Story Rest House.

with an open-fireplace and vestibuled entrance. It also provides a large number of bath-rooms, and locker accommodation in the corridors. A veranda 7 ft. 9 in. wide is built on three sides of the house. If desired showers can be substituted for baths.

The building is a frame structure 30 ft. deep by 60 ft. in length, on concrete foundations, and is lathed and plastered inside throughout.

The approximate cost under ordinary conditions, including steam heating, electric light, and drainage, is \$9500.

**Bunk Houses.** — The smaller class of building is commonly called the bunk house and these are usually provided by the railway for the trainmen only at points where crews have to lay over, when away from their home-quarters, or where the town is too far away from the junction point, or where there is no accommodation for railway men.

**C. P. R. No. 1 Standard Bunk House.** — The No. 1 C. P. R. Standard Bunk House, Fig. 173, will accommodate twenty-two men. The arrangement provides a series of rooms which hold from two to three double bunks, so that an engine crew can be accommodated in one room, the idea being that when a crew is called, the others in the house are not disturbed.

This house is 30 ft. deep by 57 ft. long, and contains five bunk rooms with 17 lockers located in the corridor, including a fair sized dining and reading room, an office or store room, a moderate kitchen, a large lavatory and a bath-room.

The structure is a frame building on concrete foundations and is lathed and plastered inside. Screen doors and windows and good ventilation are provided; a large veranda, 8 ft. wide is located at one end of the building, returning 14 ft. on the long side of the house to provide ample shade. Under ordinary conditions, this house on concrete foundation, including steam heating, electric lighting, septic tank and drainage is estimated to cost \$5000. The cubical contents is approximately 33,000 cu. ft. and the average unit price per cubic foot is 15 cents.

The two tier bunks, shown in Fig. 174, are made of iron with wire springs and post castings are provided to attach to the floor. The details are fashioned after the ordinary iron bed frame, made up of light angle and corner castings.



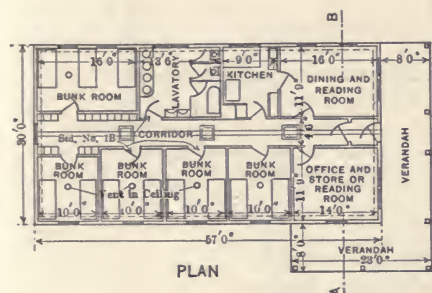
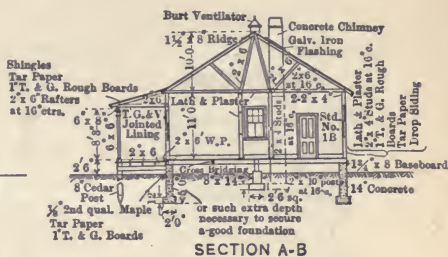
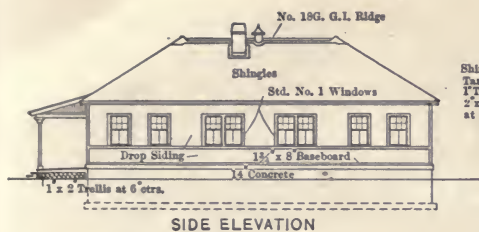

Fig. 173. C. P. R. No. 1 Bunk House.

*Approximate cost of C. P. R. No. 1 bunk house.*

Concrete and excavation .....	\$ 480.00
30,000 ft. B. M. lumber @ \$35.00.....	1050.00
Labor in erecting.....	750.00
Windows and frames.....	250.00
Outside doors and frames.....	75.00
22,000 shingles @ \$5.50.....	121.00
800 sq. yds. plaster @ 40¢.....	320.00
Spikes and nails.....	60.00
Building paper.....	24.00
Locks and fixtures.....	75.00
Painting, tinting, etc.....	240.00
Plumbing, heating and drainage.....	925.00
Bunks in place (iron).....	125.00
	4495.00
Supervision and contingencies.....	505.00
Total.....	\$5000.00

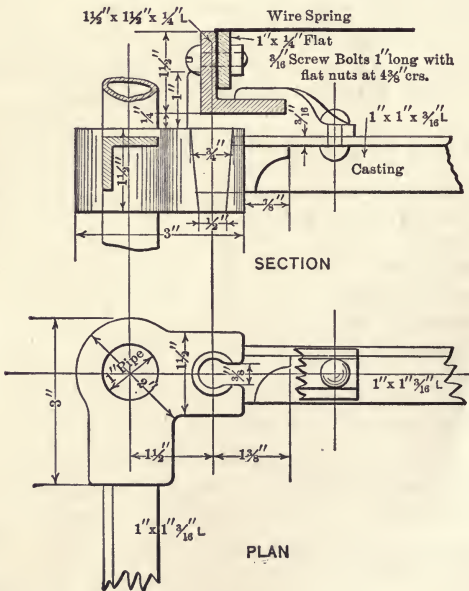
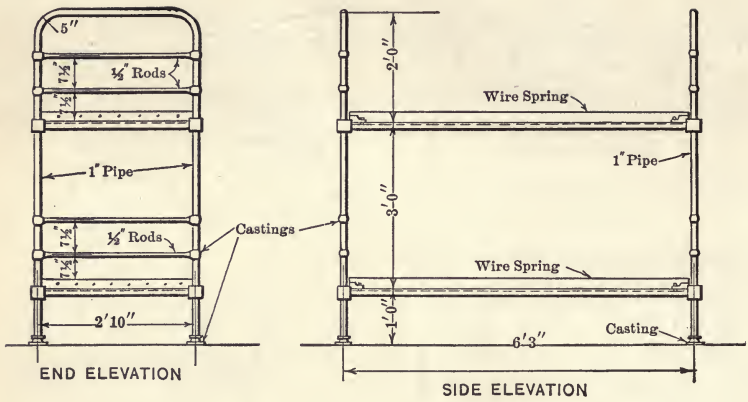

Fig. 174. Two Tier Iron Bunks.

**Small Bunk House.** — A small type of bunk house 15' × 22' to accommodate eight men is shown, Fig. 175. This house is usually built on cedar sills directly on the ground, only the chimney is built of concrete. The structure is a frame building, sheathed inside with  $\frac{3}{8}$ " V-jointed boards, and finished on the outside with T. & G. boards, a layer of felt paper and clapboards. The approximate cost of this house finished complete is \$600.

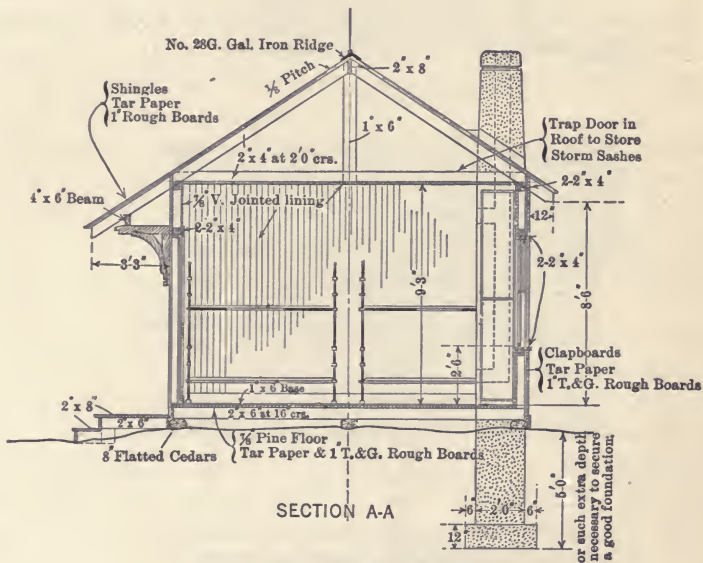
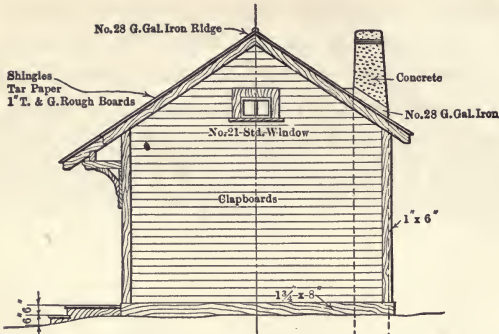

Fig. 175. Small Bunk House.

If a concrete foundation with a cellar under the full area of the house is desired the cost would be increased about \$400.

Instead of shingles being used now for roofs of this character ready roofing of various colors is quite common. The cost of shingles has gone up tremendously in the last few years and in many cases it is not as cheap a roof as the prepared roofing now on the market.

SMALL BUNK HOUSE.



END ELEVATION

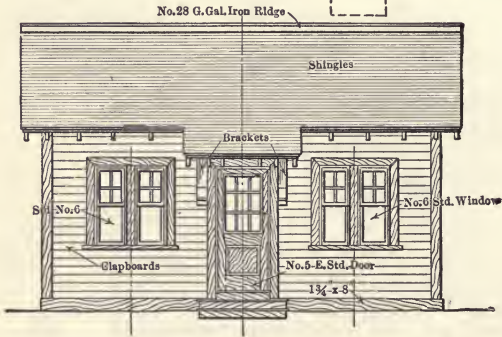

FRONT ELEVATION

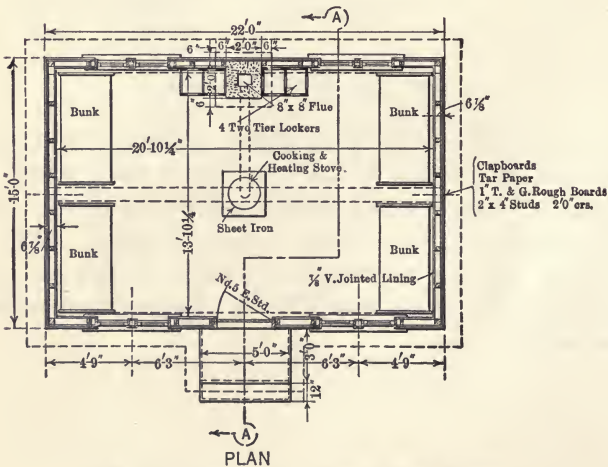

PLAN

Fig. 175 (Continued). Small Bunk House.

**Bunk House for Section Men.** — A type of dwelling for section men used on the B. & O. R. R. is shown, Fig. 176. The building is 12' × 36' of frame construction throughout. The accommodation provides a large kitchen and sleeping quarters for six double tier bunks. The house rests on wooden sills and is sheathed outside and inside with T. & G. boards. Two ventilators are installed in the sleeping-room and a smoke jack and cupboard is provided in the kitchen.

The cost of this type of building is estimated to be \$600.

**Box Car Bunk House for Section Men.** — Another type of dwelling for section men on the B. & O. Ry., using an old car body as the bunk and dining-room accommodation with a lean-to kitchen tacked on, is shown, Fig. 177.

The old car rests on a wood sill foundation and is approximately 8' × 36' with an 8' × 8' kitchen extension; four double tier bunks are provided to accommodate eight men. The car body has four sliding sash and the method of distributing the bunks at each corner of the car probably gives the maximum amount of ventilation and air space.

Figuring that old car body is worth \$50, the cost of building the kitchen extension and making the alterations, etc., to conform with the plan, the entire building is estimated to cost \$250. It should be noted that the kitchen, etc., is well ventilated and that summer blinds are provided, as well as fan lights over the doors. The larger type of houses for buildings of this character are known as rest houses, where accommodation is provided for a big crowd of men. Such houses are discussed and described on page 350.

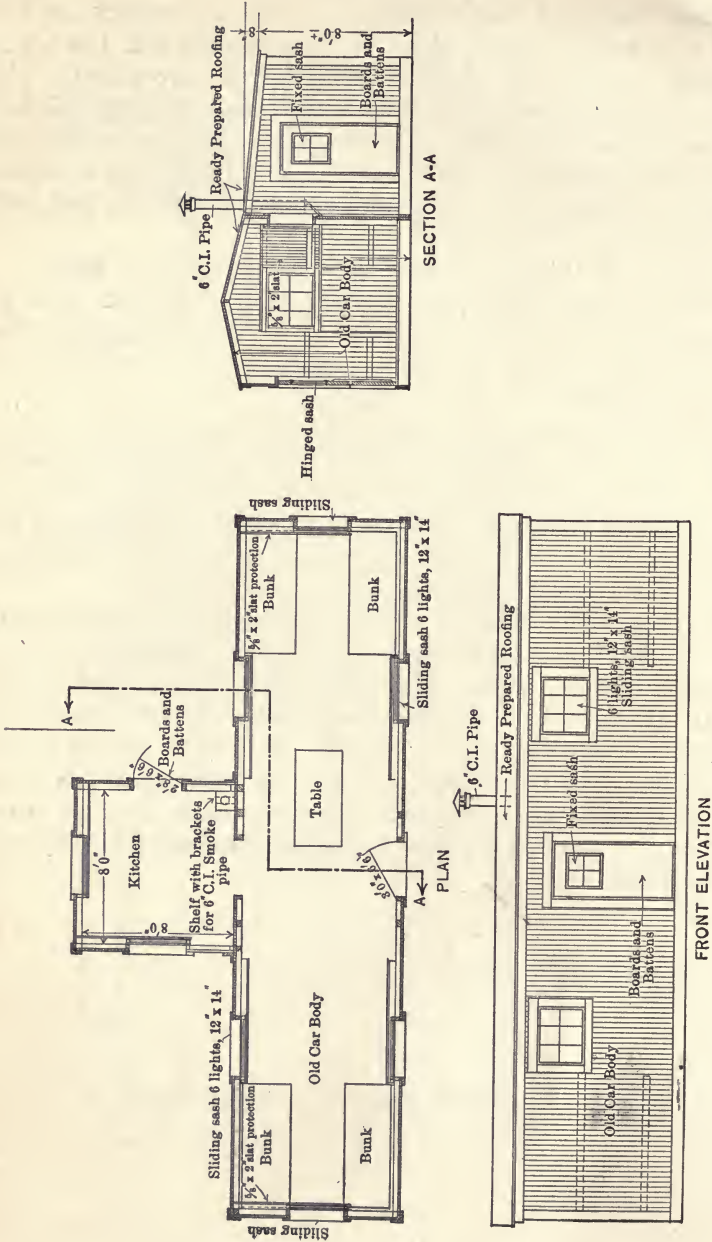

Fig. 176. B. & O. R. R. Bunk House.



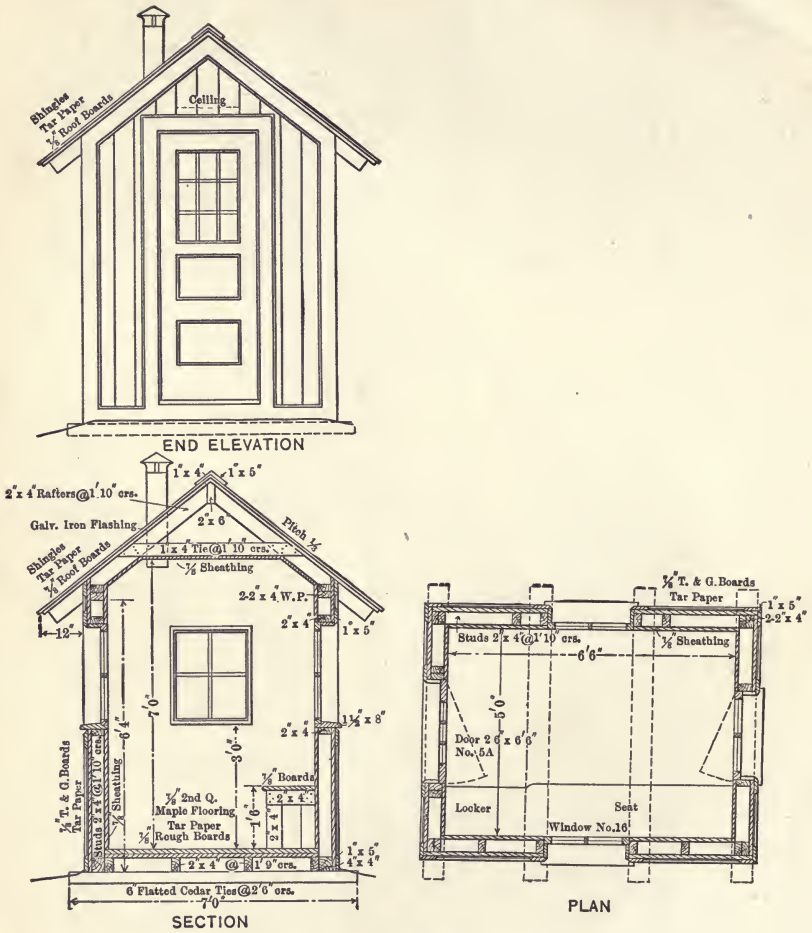

Fig. 178. Watchman's Cabin.

**Watchman's Cabin.** — A cabin 5 ft. by 9 ft. suitable for isolated locations where it is used as living quarters by the watchman is shown, Fig. 178. A seat bunk, locker and small stove are provided; in addition it is usual to include a coal or wood bin at the side or rear of the cabin. The cost of this cabin is estimated at \$75 to \$90 on wood sill foundation; the general details and construction are plainly shown on the drawings.



**Freight Sheds.**

At large freight terminals where the amount of business requires separate inbound and outbound sheds, the outbound house is usually made narrow, about 30 ft. in width, and the inbound 40 to 60 ft. in width.

To avoid the spotting of cars on the track side and also to save trucking room inside the house, a platform 8 to 12 ft. wide is sometimes provided. Where electric trucks are to be used 12 ft. should be the minimum width and it should be protected by an overhanging roof. In place of platform, continuous doors along the track side are often substituted.

On the team side, shed doors are usually provided in each bay; sometimes these doors are arranged to open outwards so as to form a shelter for the teams, but generally a roof over the door is provided for this purpose.

To assist trucking it is recommended that the floor of the inbound shed be sloped about 1 in. in 8 ft. towards the street and that the outbound shed floor be given the same slope from the street to the track. In the outbound shed scales are provided about 50 to 80 ft. apart, and in the inbound shed where very little freight is weighed one scale to each section or about every 200 ft. is sufficient. Four ton dial scales are recommended.

**C. P. R. Freight Sheds.** — A cross section of a C. P. R. freight terminal of this character is shown, Fig. 179, having a

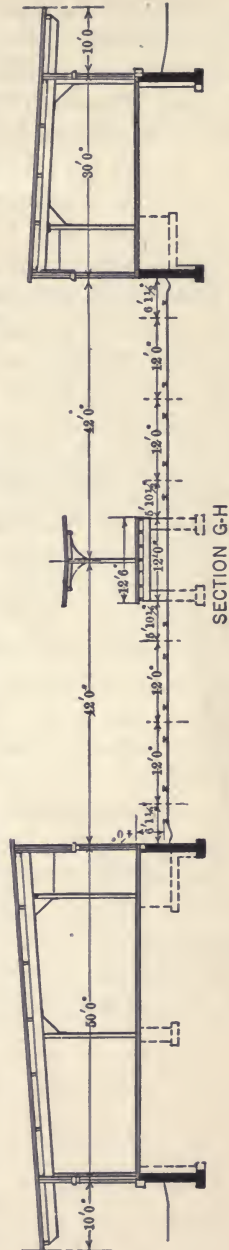

Fig. 179. Freight Terminal Sheds.

50-ft. inbound shed and a 30-ft. outbound, with six house tracks between sheds and a transfer platform in the center; the tracks are 12 ft. center to center.

**Inbound Shed.**—The 50-ft. inbound shed is shown, Fig. 180, and is of steel and concrete construction with a mill type roof. It will be noted that the floor is 4 ft. above the top of rail and that continuous doors are used on the track side, the posts being set back 7 ft. 6 in. from the front of the building to provide trucking room. In the construction of the main roof, the steel beams are cantilevered over the posts, and the entire front of building, including the sliding doors, is suspended to the cantilever beams. The interior posts are 20 ft. centers with steel eye beams running crosswise, and 8" × 12" wood purlins lengthwise. A mill roof of 2" × 3" plank laid on edge over the purlins is finished on top with a composition or tar and gravel roof. On the team side of the building the roof cantilevers 10 ft. over the roadway to form a shelter. The space between concrete walls is filled with gravel and a 3-in. narrow plank floor is laid on cedar sills. In preference to this floor 1¼-in. T. & G. boards laid on 4-in. flatted cedar sills and covered with 7/8-in. second quality maple with a layer of tar paper between boards has been substituted at the same cost. Another type is the wood block floor that gives good results if properly laid on a solid foundation. In this house 3-ton scales were located every 9th bay, or about 180 ft. apart.

Fig. 181a illustrates the track and rear elevations. The concrete foundation walls are carried up to the floor level; the doors are the continuous sliding type of wood, iron clad, hung on rollers on metal runners. Above the doors as much light as possible is introduced.

To hold the building lengthwise brace frames are inserted between posts every second panel high enough up to clear.



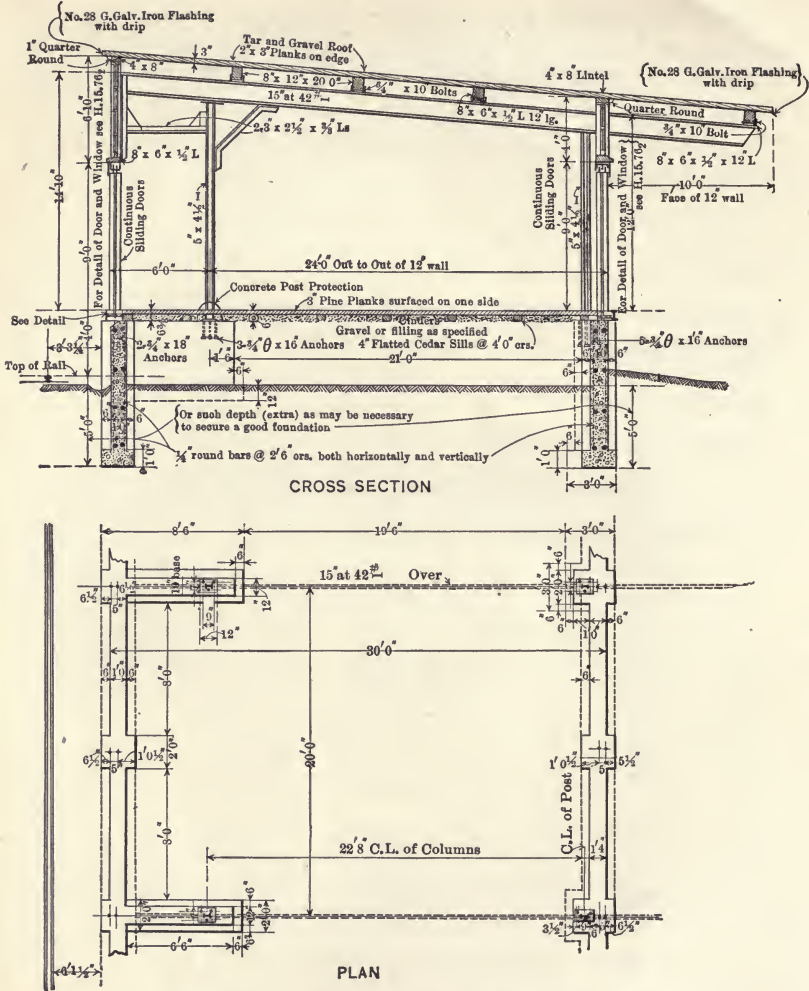

Fig. 181. 30-ft. Outbound Freight Shed (Wood Floor).

Outbound Shed. — The 30-ft. outbound shed is shown, Fig. 181, and is practically of the same construction already described for the inbound shed excepting that scales are installed every second bay or about 40 ft. apart. The sliding doors and the lights provided are shown, Fig. 181a, for the track and rear elevation.

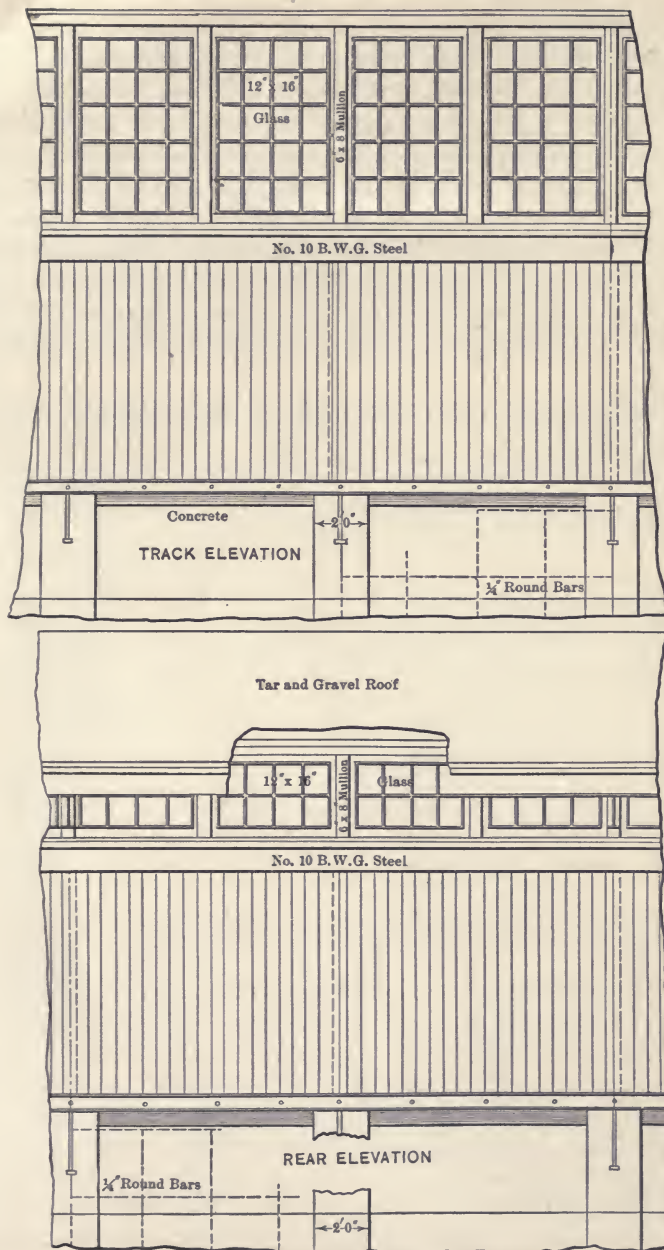

Fig. 181a. 30-ft. and 50-ft. Freight Shed Elevations.

**Cost of Inbound and Outbound Sheds.** — The cost of these sheds with wooden floor on fill was estimated at \$1.50 to \$1.75 per square foot for ordinary foundations. Where wood piles were used the cost was \$1.85 per square foot and where concrete floor and concrete piling were used the cost was \$2.25 per square foot. The cost of the office building averaged 18 cents per cubic foot.

The above prices are for the building complete, ready for occupation, including electric lighting, scales, heating, plumbing, and ordinary light fixtures as well as two fire hydrants in each section with a hose cabinet and 150 ft. of hose. The estimated and actual cost of the freight terminal, built in 1914, was as follows:

*Estimated cost:*

Inbound shed 50' × 920', 46,000 sq. ft.	}	@ \$1.50	\$114,000.00
Outbound shed 30' × 1000', 30,000 sq. ft.			
Transfer platform 12½' × 980', 12,250 sq. ft.,		@ \$1.10	13,475.00
			<u>\$127,475.00</u>
Offices: two story, 362,000 cu. ft. @ 18¢			65,160.00
Small portion of sheds, covered platform, etc.			6,740.00
			<u>\$199,375.00</u>

*Actual cost:*

Structural steel and erection	\$32,386.00
Sheds, transfer platform and office building	140,429.00
Electric lighting and heating	8,313.00
Scales	4,788.00
Engineering and supervision	13,459.00
	<u>\$199,375.00</u>

*Unit prices, per sq. ft., sheds and platform:*

Average cost of sheds per sq. ft.	\$1.075
Cost of steel, 7 lbs. @ 3.375¢ per lb.	0.230
Cost of lighting per sq. ft.	0.043
Cost of scales per sq. ft. (1 every 3200 sq. ft.)	0.063
	<u>\$1.411</u>
Add for engineering 5 per cent approx.	0.089
Total cost per sq. ft.	<u>\$1.50</u>
Approximate cost of transfer platform per sq. ft.	1.00
Cost of electric lighting	0.044
	<u>\$1.044</u>
Add for engineering 5 per cent approx.	0.056
Total cost per sq. ft.	<u>\$1.10</u>

*Unit prices, cu. ft., office building:*

Cubic contents of office building taken from bottom of footings to top of roof, 362,000 cu. ft.	
Cost of office building, 18¢ per cu. ft.	
Cost per cu. ft. for builder's contract	11.42¢
Structural steel including erection	3.66
Electric lighting contract	0.53
Heating contract	0.73
Engineering	1.66
Total cost per cu. ft.	<u>18.00¢</u>

**Transfer Platform.** — The transfer platform is shown, Fig. 182. The posts are 20 ft. apart and the roof is of the butterfly type. Concrete piers are placed 20 ft. centers and the floor is built of 3" × 8" joists and 3-in. plank resting on 8" × 12" sleepers. The roof consists of steel brackets fastened to the posts, on which are placed three 6" × 10" × 20' purlins and a 2-in. plank covering, the plank cantilevering 1 ft. 9 in. over the main roof beams. The roof is finished with tar and gravel or composition. Downspouts 4 in. square are placed every 40 ft. to carry the rain water from the roof. The cost of this type of transfer platform is estimated at \$1.10 to \$1.25 per square foot.

**Cross Trucking and Bridges.** — In the Los Angeles local freight terminal of the A. T. & S. Fé, three power operated transfer bridges have been installed as a means of reducing the cross trucking distances. These bridges are illustrated in the *Railway Age Gazette*, July 21, 1916.

The terminal consists of two buildings about 1000 ft. long, separated by seven house tracks, divided into three groups by two platforms each 16 ft. wide and connecting with a cross platform at the stub end. Transfer bridges have been built at two points on the length of the shed to permit cross trucking a cut being made in a string of cars opposite each bridge, when cars are placed, to allow room for the bridge.

These structures consist of gallows frame of steel, spanning the center pair of tracks, on which is supported the operating machinery from which the three drawbridges are raised and lowered.

The bridges consist of steel beams carrying a plank floor; one bridge spans three tracks and is about 43 ft. long, and the other two are about 29 ft. long each. Between tracks heavy sills are placed on the center line to form supports for the swinging legs which are used as intermediate supports to reduce the span length.

The spans are operated by means of cable winding on drums by 7½ horsepower 3 phase 60 cycle alternating current motors. Worm drums are used without brakes. One 7½ horsepower motor operates the 3-track bridge and another of the same size operates the two smaller ones simultaneously.

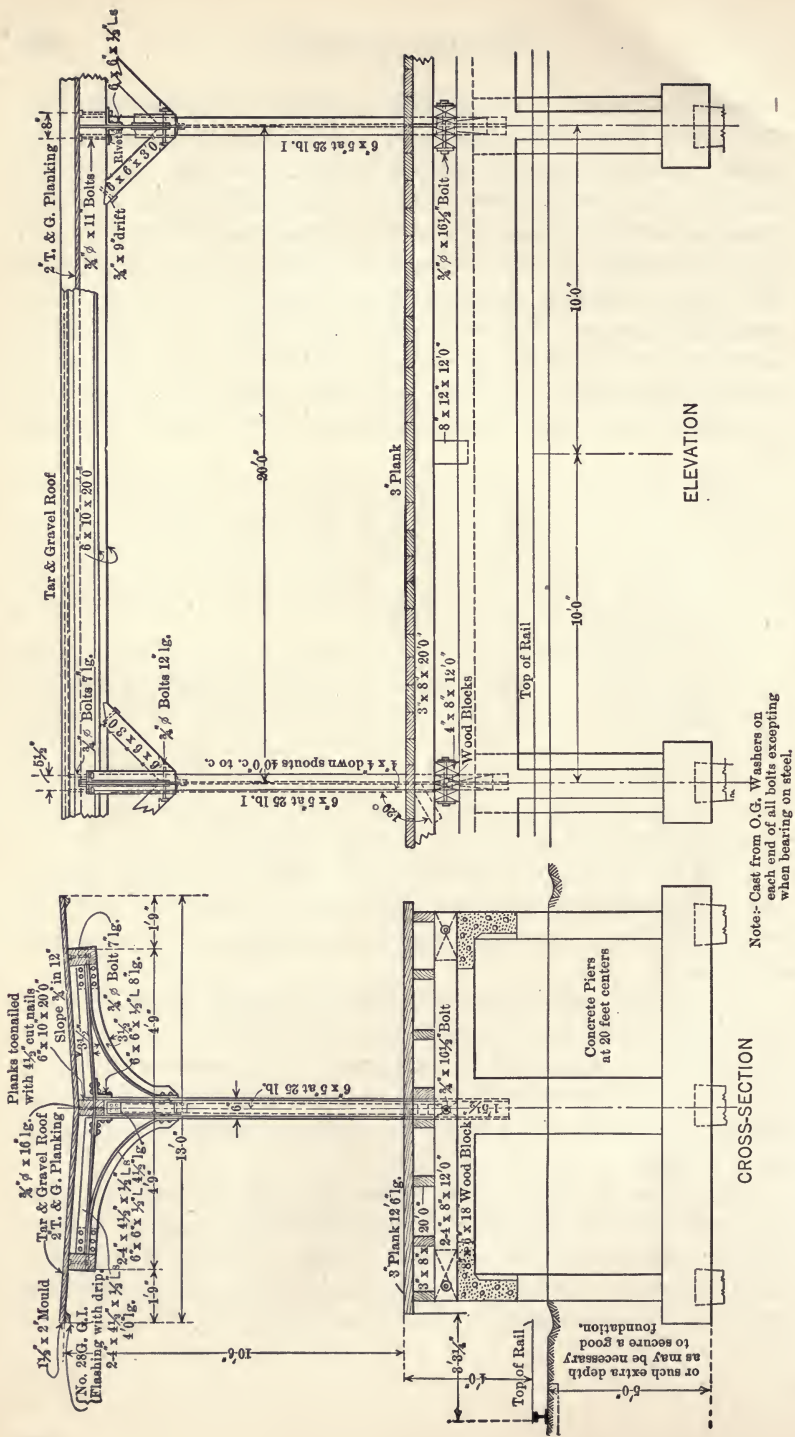

Fig. 182. Transfer Platform.



**Local Sheds.** — When posts are not objectionable inside the house, the flat roof construction is probably the simplest and cheapest for this class of building.

In long wooden sheds, brick gable walls are built at each end, and at intervals of 50 to 100 ft. fire walls are inserted, the walls being carried 12 to 24 in. above the roof, capped with a coping of concrete, stone, or tile.

Hand sprinklers and fire hydrants are also introduced throughout the house for fire protection, and in many cases the sprinkler system is installed. This consists of a series of main and branch water pipes. The mains are carried up at frequent intervals, and the branches are carried across the ceiling fairly close, and equipped with sprinkler heads that automatically open when the temperature exceeds a certain limit. Scales are also provided to weigh freight when desired.

Fig. a illustrates a 32 ft. wide shed, 14 ft. high, with trucking platform on track side, posts 16-ft. centers both ways. The doors on the track side can be hung on a double trolley track overhead, so that they may slide by each other, or on sheaves, with counterweights, to slide up similar to the ordinary English window. The doors on the road side may be 16-ft. or 32-ft. centers, the balance of the construction as per sketch.

*Approximate cost.* — \$1.25 to \$1.75 per square foot (concrete floor), or 7 to 10 cents per cubic foot (concrete floor), ordinary foundations.

Fig. b illustrates a 40-ft. wide shed, 14 ft. high, without platforms, with two inner rows of posts at 16-ft. centers either way. The roof joists towards the track side are cantilevered out 8 ft. and carry the doors and lights over. With this arrangement, and the doors hung on a double trolley track, so that they slide past each other, there are no posts to interfere with car doors, and truck platforms are not necessary. The balance of the construction is shown on the sketch.

*Approximate Cost Complete.* — \$1.50 to \$2 per square foot (concrete floor), or  $7\frac{1}{2}$  to 12 cents per cubic foot, ordinary foundations.

Fig. c illustrates a 52-ft. wide freight shed with platforms both sides, wood floor and overhanging roofs. The front posts are 8" × 10" at 8-ft. centers, the inner posts 8" × 10" at 16-ft.

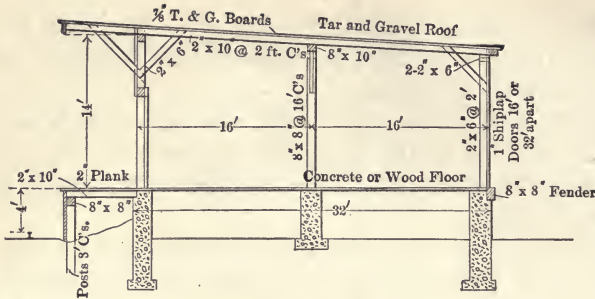

Fig. a.

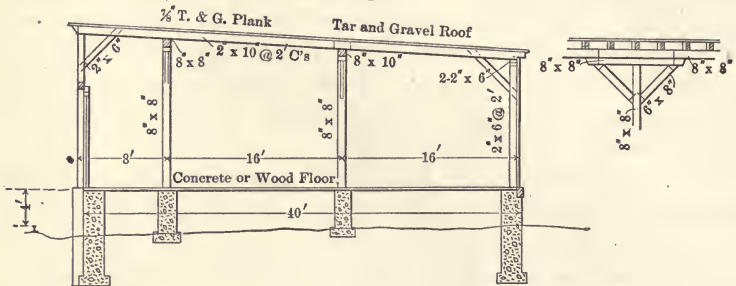

Fig. b.

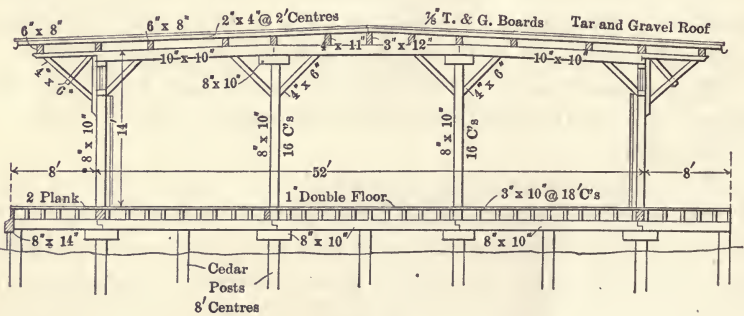

Fig. c.

Local Freight Sheds.

centers. The doors on both sides are placed 32-ft. centers, and are hung on pulleys and weights similar to the English sash windows, so as to slide up. The balance of construction is shown on the sketch.

*Approximate cost complete.* — 75 cents to \$1.25 per square foot of building or 3 cents to 6 cents per cubic foot of building, ordinary post foundation.

**Freight sheds**, 50 cents to 75 cents per square foot. When covering a large area with suitable ground, so that the floor rests on natural soil, construction 6" × 8" posts, 16-ft. centers across and along the house, the posts resting on cedar sills.

The main roof beams are 8" × 10", corbeled over the posts and bracketed at each side, the rafters 2" × 8" at 2-ft. centers, with 1" × 2" bridging,  $\frac{7}{8}$ -in. roof boards on top, and finished with tar and gravel or ready roofing. The posts are held crosswise by 2" × 4" braces.

The floor is second quality hardwood on  $\frac{7}{8}$ -in. rough boards, with tar paper between, on 3 to 6-in. flatted cedar sills embedded in the ground.

A wood-built wall of 6-in. cedar posts and 3-in. planks is made along the track sides. The doors are hung on a double trolley track so as to slide past each other.

**Freight shed**, 75 to 100 cents per square foot. This is somewhat similar to above, excepting that the floor is raised about 4 ft. above the natural ground.

The B. & O. Freight Shed, Fig. 183, is a convenient type of shed to attach to an ordinary way station where the business is too large to handle in conjunction with the station. The sizes of such buildings usually vary to suit conditions. The average width is 20 ft. and the length may be 20 ft., 30 ft., or 40 ft., or more. Where conditions are favorable, concrete foundations are built, but generally wood sill or wood posts are used, and the balance of the building is of frame construction. The floor joists are 2" × 12" at 16-in. centers, covered with  $\frac{7}{8}$  rough boards and finished with second quality maple or other hardwood. The walls are of 2" × 6" studs at 24 in. centers, double sheathed on the outside and lined inside for a height of 5 ft. The roof timbers are also 2" × 6" at 24 in. centers, covered with T. & G. boards and either shingled or finished in slate or ready roofing.

The cost of this class of building is approximately, for the various sizes, as follows:

	Concrete foundation.	Wood foundation.
20' × 30' without platform.....	\$1200	\$950
20' × 40' without platform.....	1600	1250
20' × 50' without platform.....	2000	1600

The platform may be estimated at 30 cents per square foot.

SMALL FREIGHT SHED.

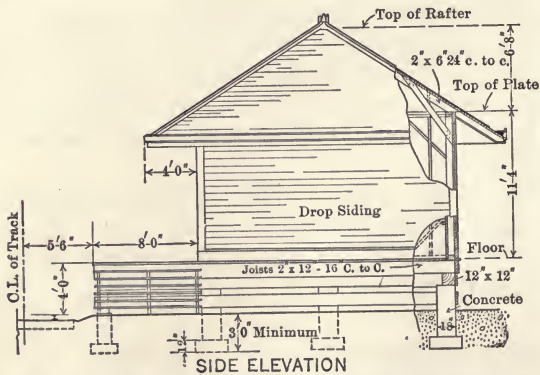
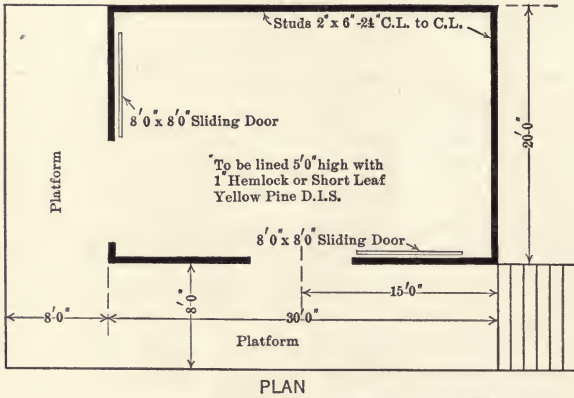
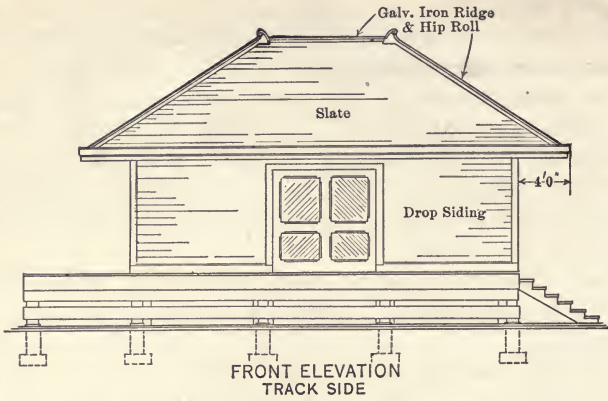

Fig. 183. B. & O. R. R. 20' by 30' Freight Shed.

C. P. R. standard freight sheds, Figs. 184, 185 and 186 are of flat roof construction with concrete or wood foundation. The shed posts are 8" × 10" at 16-ft. centers, resting on wood or concrete sills; the main roof beams are 8" × 14" at 16-ft. centers running longitudinally, supported on 8" × 10" corbels, and braced with 6" × 9" struts. The roof timbers are 3" × 12" at 2 ft. centers and it will be noted that they cantilever 7 ft. 6 in. over the first row of posts and that the front doors and fanlights are hung from them. The doors slide in two separate trolley tracks so that one door slides past the other; by this arrangement no platform is necessary alongside the track as the front posts are far enough back to provide ample trucking room and one-half of the entire shed can be opened up at one time if desired.

The roof timbers are covered with 1½-in. T. & G. boards over which is nailed a layer of felt paper well lapped; a finished roof of ordinary tar and gravel is then placed on top.

The floor may be 3" × 12" wood joists at 18-in. centers covered with rough boards and finished with hardwood on top, the joists resting on wood sills, or the portion between walls may be filled and the floor laid on ordinary flatted timbers, or a concrete floor 4-in. thick finished with mastic or other composition may be used.

The cost of this type of freight shed, per square foot of area, for the three different kinds of floor specified for sheds with continuous doors, and sheds with platform in front and one door to each bay, is about as follows:

Freight sheds with continuous sliding doors.	Different widths of sheds.		
	30 ft.	40 ft.	50 ft.
	Fig. 186.	Fig. 184.	Fig. 185.
Shed with wood floor on joists.....	\$1.60	\$1.45	\$1.35
Shed with wood floor on fill.....	1.70	1.55	1.45
Shed with concrete floor on fill.....	1.90	1.75	1.65
Freight sheds with platforms in front.			
Shed with wood floor on joists.....	\$1.50	\$1.35	\$1.25
Shed with wood floor on fill.....	1.60	1.45	1.35
Shed with concrete floor on fill.....	1.80	1.65	1.55

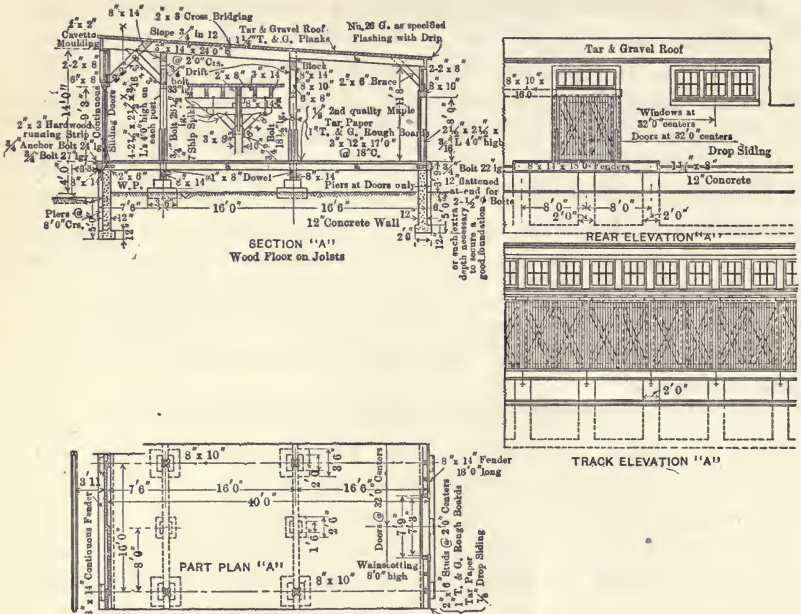

Fig. 184. C. P. R. 40-ft. Freight Shed without Platform.

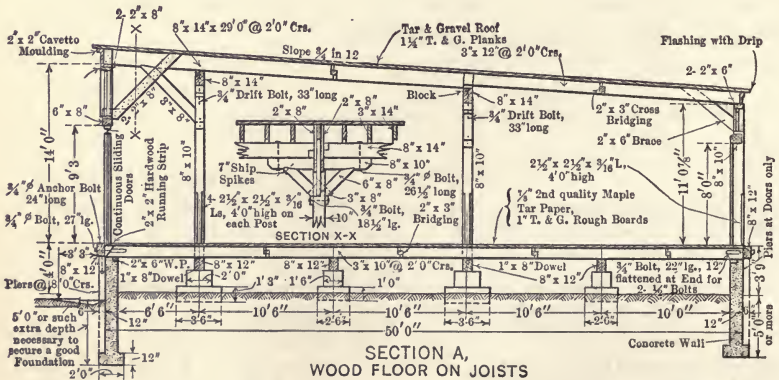

Fig. 185. C. P. R. 50-ft. Freight Shed without Platform.

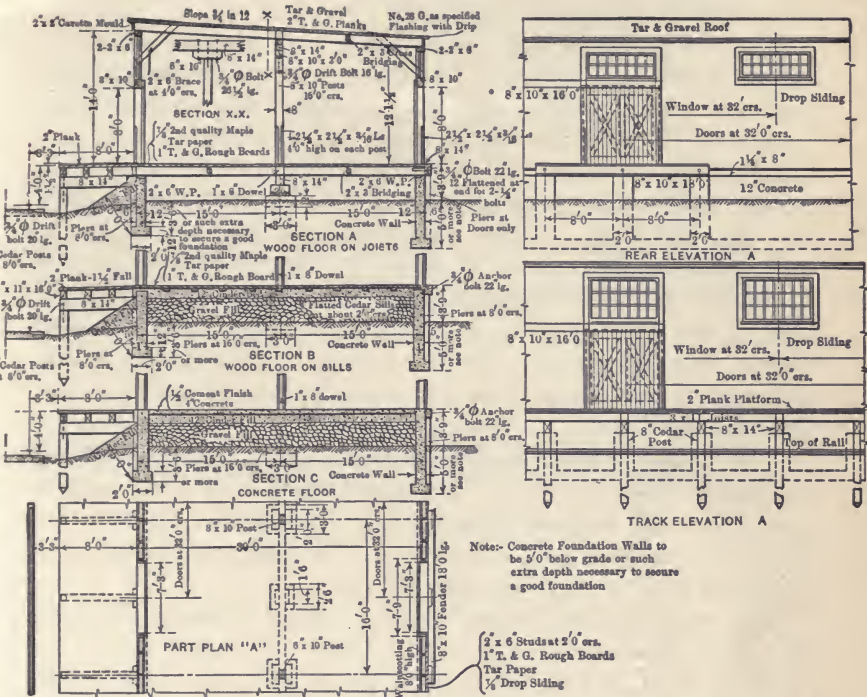

Fig. 186. C. P. R. 30-ft. Freight Shed with Platform.

In the foregoing illustration, Fig. 186, are shown three types of floors. The first is a wooden floor supported on joists and run beams, the second is a wooden floor on a fill, and the third is a concrete floor on a fill. The concrete or filled floor should only be used when the fill is good and solid; where there is a doubt it would be better to use a wooden floor with a maple finish on top.

### Station and Freight Shed Platforms.

**Platforms.** — The principal platforms built on the railway are those used at passenger and freight stations.

The low platform, that is a platform level with top of rail or a few inches above top of rail on account of car equipment clearance, is in general use; with a higher type such as that shown in Fig. 189 for use in third rail territory. At freight stations the platforms are invariably high. For stations, combining freight and passenger service, a combination of high and low platforms is built connecting one with the other by ramps.

At low platforms, baggage ramps are usually built at either end of the main platform so as to facilitate trucking over the tracks, Fig. 188, where there are two or more platforms, or in some cases one crossing ramp is made about the center of the platform.

The clearance from gauge side of rail and height of platform is usually governed by the car equipment in use or by orders issued by the Railway Boards, etc. A common figure is to place the platform 2 ft. 6 in. to 3 ft. 0 in. from gauge line, at a height of 5 to 12 in. above base of rail.

The Pennsylvania clearance for passenger platforms is 2 ft. 6 in. from gauge line and 6 in. high above top of rail; the N. Y. C. & H. R. R. is 2 ft. 10 $\frac{3}{4}$  in. from gauge and 12 in. high above base of rail and the C. P. R. 3 ft. from gauge and 5 in. above top of rail.

The length of platforms is dependent upon the average length of the regular trains stopping at the station and the amount of passenger business transacted. It is usual to keep the platform 12 to 20 ft. wide opposite the station proper and then to converge to 8 or 12 ft. on either side.

It is considered that ample and conveniently arranged platforms, especially when covered and provided with benches, will allow of a smaller accommodation being provided inside the passenger station; especially would this be the case for suburban service or pleasure resorts where large crowds are handled.



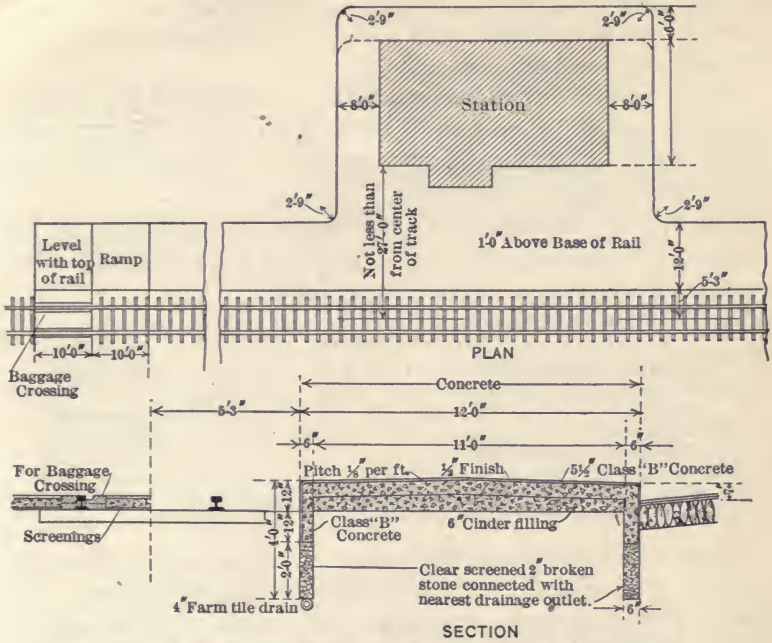

Fig. 187. N. Y. C. & H. R. R. R. Concrete Station Platform.

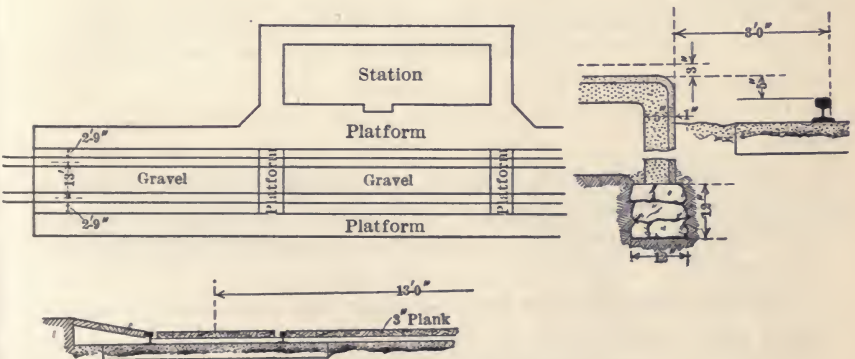

Fig. 188. C. P. R. Station Platform.

**Passenger Platforms.** — The use of timber for station platforms has been largely superseded by permanent material such as brick, concrete, asphalt, cinders with a coating of limestone screening, tar, macadam and other compositions.

Where brick or other surface coatings are used, it is generally necessary to build a concrete base and concrete or stone curbs at the edges, providing in all cases good drainage if the best results are desired.

The cost of the different platforms will vary according to local conditions, etc.; the average prices for estimating purposes under normal conditions are as follows:

*Cost of station platforms.*

	Per Sq. Ft.
Wooden platforms on sills . . . . .	18¢ to 25¢
Brick (vitrified) laid flat on 18-inch cinder bed and 1-in. sand . . . . .	25¢ to 30¢
Brick (vitrified) 4-in. concrete base and cinder fill . . . . .	35¢ to 45¢
Concrete laid on cinder fill . . . . .	25¢ to 35¢
Cinder fill 2-in. top limestone screenings . . . . .	18¢ to 25¢

The above figures do not include stone or concrete curb. A 5" X 24" sandstone or concrete curb costs from 50¢ to \$1.25 per lineal foot in place.

The brick platform is said to have a better footing than the concrete type especially in cold climates subject to snow and frost. With permanent material water drains off very readily, usually towards the track, for which there should be provided tile or other pipe at the bottom of the curbing to take care of drainage.

The concrete platforms, Fig. 187, N. Y. C. & H. R. R. R., which are a fair average for this class of work, are constructed as follows:

Platform is divided into blocks of not more than 40 sq. ft. area.

Curbs are constructed adjacent to tracks and driveways only.

If more than one passenger track is used, a 12-ft. 0 in. platform opposite and outside of additional passenger track or tracks is provided.

The platform work is kept covered and moistened for one week after completion. A system of metal reinforcement is used in the construction of the platform and curbs.

In wet ground or where the volume of drainage is large a 4-in. farm tile drain as indicated on the section is used under the curbs.

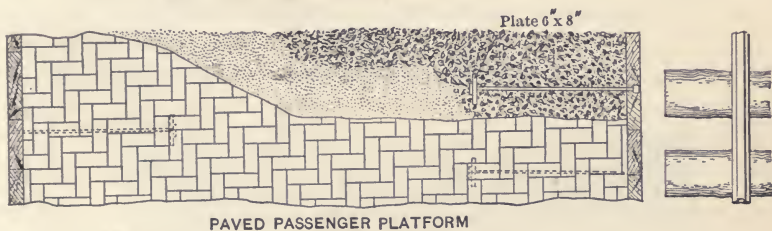
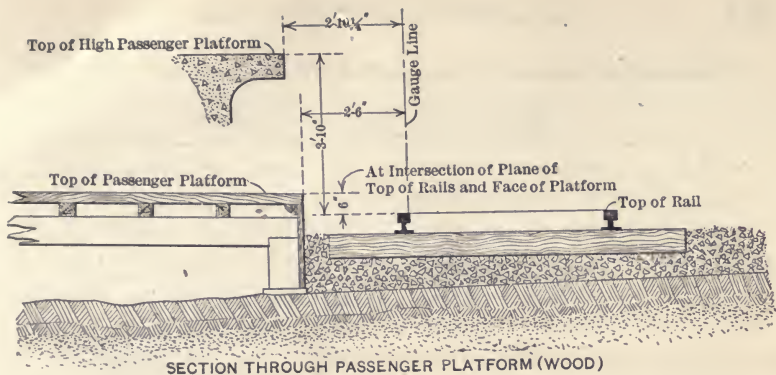

At Unimportant Stations Old Timbers should be used instead of Stone Curbing and Platforms should be made of Stone Screenings, Cinders or other Suitable Material.

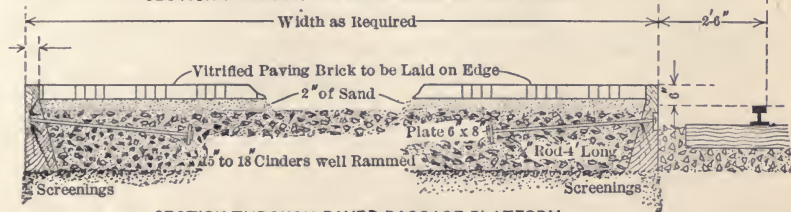
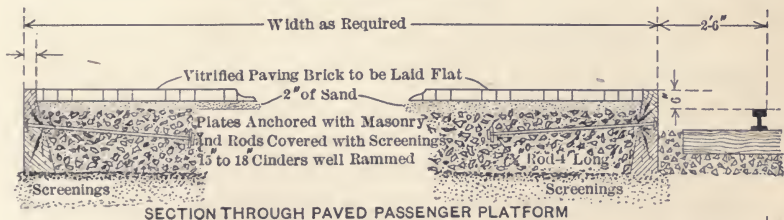
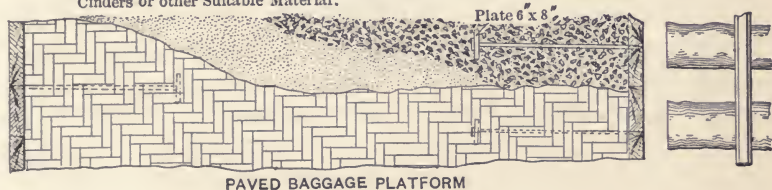

Fig. 189. P. R. R. Station Platforms.

Platforms are usually constructed 200 ft. long.

TABLE OF CONCRETE PROPORTIONS.

Class.	Cement.	Sand.	Stone.
"B".....	1 part	3 parts	6 parts
Finish.....	1 part	1½ parts	0

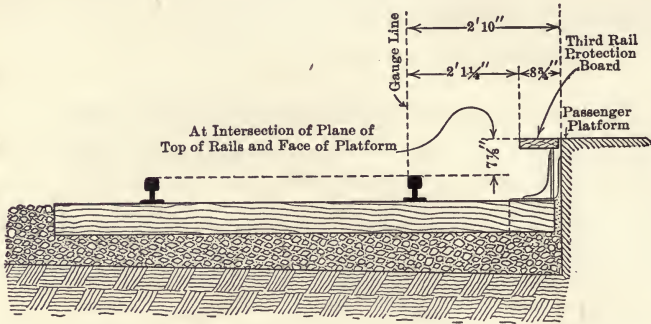

Fig. 190. Height and Distance from Rail for Low Passenger Platforms for Electrified Track.

**Freight Platforms.** — At points where the freight shed is at one end of the station building, either as an extension or a separate building on the main line, it is impossible to unload car-load freight or heavy machinery. On this account it is sometimes necessary to erect unloading platforms on the siding delivery track, where machinery or car-load freight can be handled.

The platforms vary in width from 8 to 24 ft. or more, and should not be less than a car length, or about 30 ft., with a ramp at one end, Fig. 191.

*Approximate cost.* — The cost of such platforms varies from 25 cents to 50 cents per square foot erected complete.

**Paving Freight Shed Teamways.**

*Approximate cost.* — Paving, including filling excavation and gutters per square yard, \$2.25 to \$3.25. Concrete curbing 1 ft. wide by 1 ft. 6 in. deep, per lineal foot in place, 60 cents to \$1. 12-inch vitrified tile drain pipe in place, per lineal foot, 75 cents to \$1.

*Grading.* — Roadway excavated or filled or both to insure a good foundation and to conform with subgrade.

Excavate for the curbing to such depths as may be required to properly set the same and insert a bed of broken stone 3 or 4 in. thick before concreting. Fill to subgrade with good gravel, thoroughly pounded, or rolled, and water if necessary before rolling, all soft material to be removed before filling, surplus material to be deposited as directed or removed.

**Paving.** — Over the prepared subgrade, lay a bed of clean sharp sand, not less than  $1\frac{1}{2}$  in. or more than 3 in. thick, well watered and rolled to a hard surface, to established levels.

Blocks to be  $4\frac{1}{2}'' \times 5\frac{1}{2}'' \times 10''$  to 15 in. long or thereabout, free from cracks or defects, laid in straight lines and in close contact at sides and ends, to break joints at least 3 in., each row tightened from end to end before closure is inserted; the whole when laid to be well rammed and rolled and brought to a true cross-section, and the joints filled with sand.

*Drainage.* — 12-in. tile pipe connecting with manhole, laid to established grades with cement joints.

FREIGHT PLATFORMS.

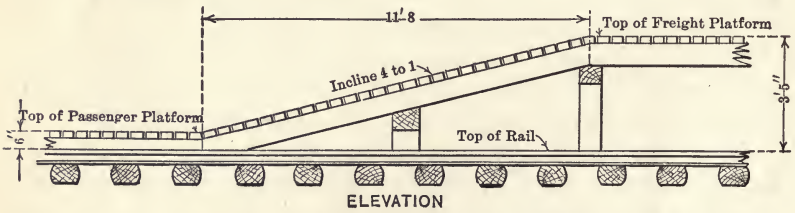
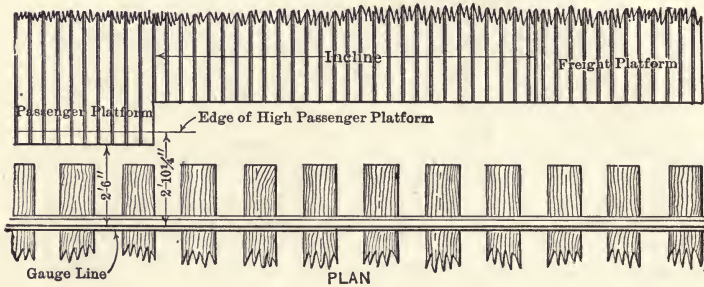
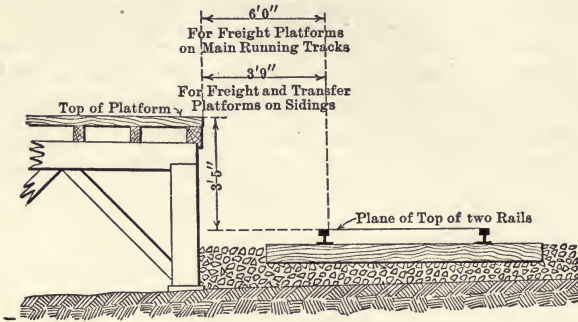

Fig. 191. P. R. R. Standard Section through Freight and Transfer Platform.

**Loading Platforms.** — Two types of grain loading platforms, as used by the C. P. R. at points where grain is shipped, are shown, Fig. 192. It will be noted there is a 1 in 10 ascending grade and 1 in 6 descending.

The filled platform with a retaining wall parallel with the track, made of ties, is the cheaper one if the filling can be obtained at a reasonable rate. Figuring this at 50 cents, the cost per square foot would be about 15 cents.

The approximate cost of filled platform as shown would be as follows:

180 track ties, 8 ft. long @ 75¢.....	\$135.00
260 lb. iron in track ties @ 5¢.....	15.00
400 cu. yd. fill @ 50¢.....	200.00
Miscellaneous.....	35.00
Total.....	<u>\$385.00</u>

The trestle type of platform is more expensive, and where traction engines are used for hauling the 3" × 10" joists at 1 ft. 9 in. centers should be increased to at least 4" × 10" at 15 in. centers. The cost of this type of platform varies from 50 to 60 cents per square foot.

The approximate cost of timber platform, as shown, would be as follows:

Timber, 19,000 F. B. M. @ \$40.00.....	\$760.00
Iron in timber, 1900 lb. @ 5¢.....	95.00
Filling, 50 cu. yd. @ 75¢.....	37.00
Miscellaneous.....	88.00
Total.....	<u>\$980.00</u>

Comparing the two estimates given above, the filled platform is much cheaper, and in place of the wooden walls a similar method of cribbing with concrete ties, when conditions are favorable, would make this form of construction much more permanent than the wooden trestle.

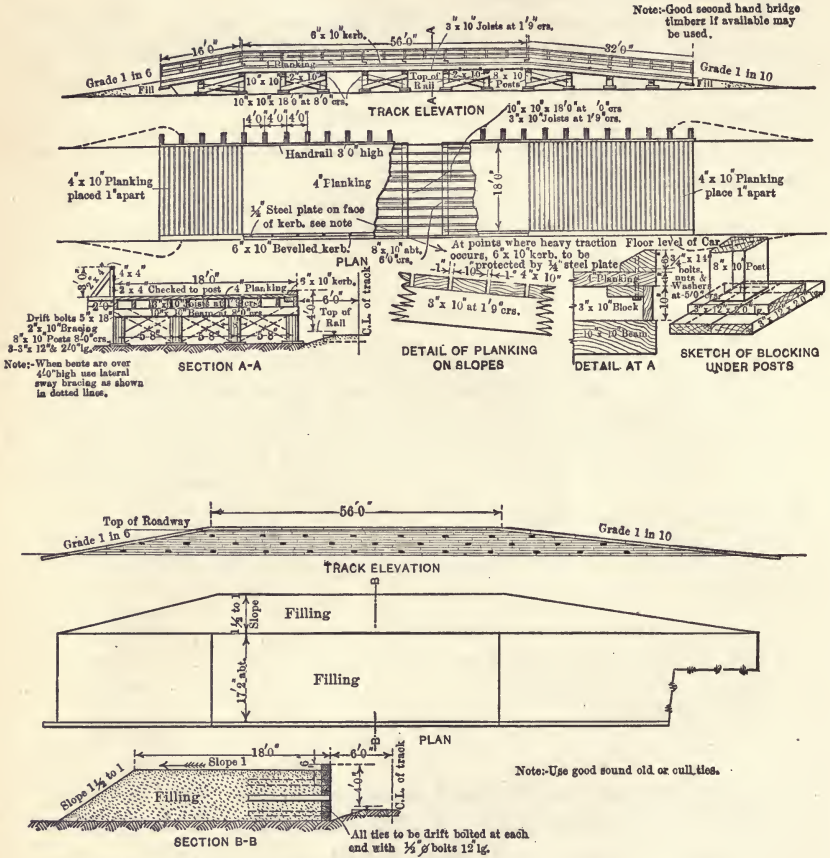

Fig. 192. C. P. R. Grain Loading Platforms.



**Portable Scales.**— At small stations, usually portable scales of about 2000 lb. capacity are used unless there is considerable weighing of individual baggage when a stationary scale may be necessary. (Fig. 192a.)

PORTABLE PLATFORM SCALE WITH DROP LEVER  
CAPACITY 2000 LBS.

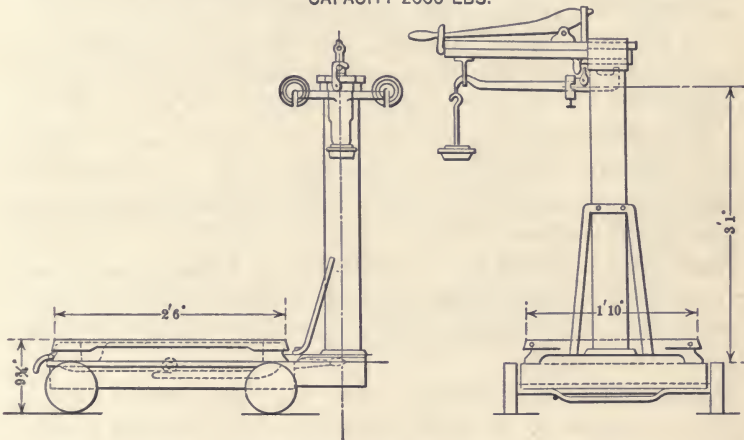

Fig. 192a. Portable Platform Scale with Drop Lever.

**Electric Motor Trucks.**— The electric motor baggage truck floor is about 30 in. high and is 9 to 12 ft. long, and about 44 in. wide. A modification of the baggage truck has a floor only 9 in. high for use in depressed track stations.

Warehouse trucks have a depressed portion at one end to facilitate loading and delivery of the load into the end of a freight car. Height 10 in., width about 40 in. and length over all about 9 ft.

With the object of avoiding entirely the necessity for turning around, the trucks are usually constructed with double end control, which permits of operation with equal facility in either direction.

Space required to turn is reduced by steering four wheels instead of two and operation is made identical in either direction and eliminates the practice of running two-wheel steering trucks backward.

Sufficient traction for all ordinary work is available with

two-wheel driving and therefore four-wheel driving complication is avoided.

The voltage adopted on the Pennsylvania was 24 volts as the minimum. The 24-volt battery has the minimum number of cells and connectors and consequently the minimum possibility of jar and connector breakage, the minimum cost per unit of capacity and weight per unit of capacity.

It is not customary to weigh express goods on trucks nor commercial express excepting when there is a considerable quantity.

Capacity 4000 lb. as a maximum with a 50 per cent overload factor that can be handled quickly and safely in congested enclosures, in consideration of the absolute necessity of quick stopping and position control.

High speed has been found of little or no value for the reason that speed is limited by the amount of congestion, etc., and is about 6 to 7 miles per hour with the empty truck and 5 to 6 miles an hour loaded.

**Station and Freight Scales.** — The average distance between center of wheels of an ordinary three-wheel baggage truck is 6 ft. 6 in. to 8 ft. 6 in. and the average width center to center of tires 3 ft. The front wheel diameter is 1 ft. 3 in. and the rear wheel 1 ft. 11 in.

The average distance between center of wheels of an ordinary express truck is 6 ft. 6 in. and the average width center to center of tires 3 ft. The front wheel diameters are 2 ft. 4 in. and the rear wheel 2 ft. 6 in.

To accommodate baggage, express and freight trucks the C. P. R. standard 3-ton stationary scale platform is 4' 6" × 9', Fig. 193.

The cost of a 3-ton dial depot scale complete, Fig. 193, varies from \$350 to \$450; an average estimate of work is as follows:

Excavation, 10 cu. yd. @ 50¢ .....	\$ 5.00
Concrete, 1.25 cu. yd. @ \$10.00 .....	12.50
Lumber, 440 F. B. M. @ \$50.00 .....	22.00
2-9 in. I beams, 21 lb., 3 ft. 9 in. long, 157 lb. @ 6¢	9.42
Contingencies.....	<u>5.08</u>
	\$ 54.00
Scale irons and dial case.....	346.00
Erection.....	<u>25.00</u>
Total.....	\$425.00

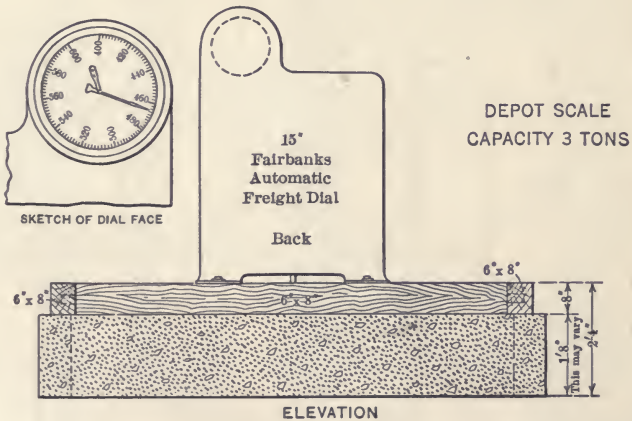
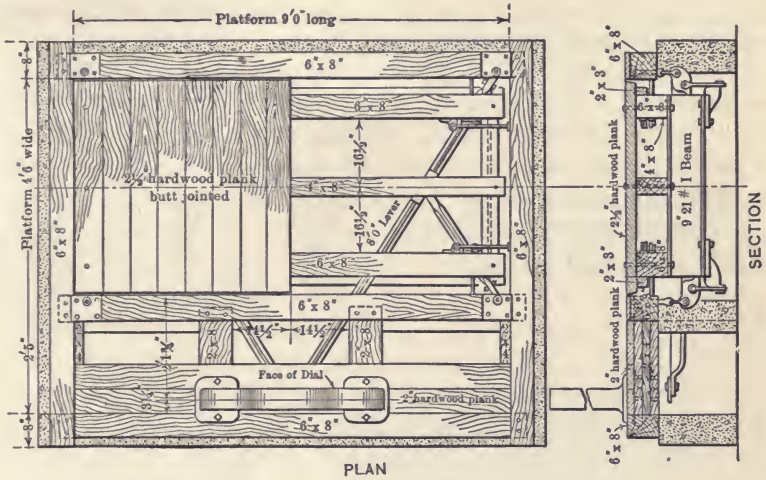

Fig. 193. Three-ton Depot Scale.

**Wagon Scales.** (Fig. 194.)— There are two types of wagon scales in general use. One is known as the Trussed Lever Pit Pattern and the other as the Suspension Wagon Scale. The latter is a little more expensive than the former for the scale irons. Their costs are about as follows:

APPROXIMATE COST OF WAGON SCALES.

Material.	8'x14', 10 ton.	8'x14', 15 ton.	8'x22', 20 ton.
Scale irons platforms.....	\$175	\$200	\$300
Pit with concrete walls and floor...	130	130	200
Timber, frame and floor over scale	50	52	82
Hardware and miscellaneous.....	45	43	68
Cost in place.....	\$400	\$425	\$650

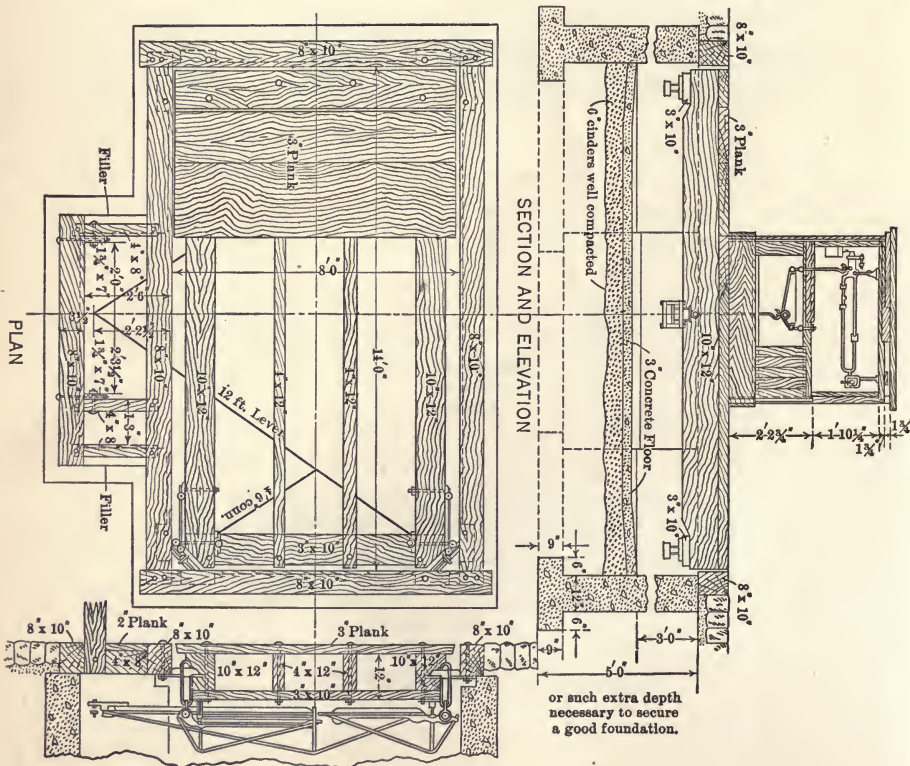

Fig. 194. Ten-ton Wagon Scale.

**Freight Yard Cranes.** — Handling heavy machinery and other material from flat cars can best be accomplished with power by means of cranes placed straddling one or two tracks and a team way in the yard.

A 40-ton electric freight yard crane for this purpose was erected in the west yard of the N. Y., N. H. & H., in Providence, R. I., consisting of a 4-motor electric traveling gantry crane with a main lift of 40 tons, and a higher speed auxiliary hoist of 5 tons capacity. Span center to center of runway rails 55 ft. 6 in., covering a wide driveway and two tracks, range of crane travel about 300 ft. The cost of the crane installed, including foundations, was about \$14,000, and the expense of operation is about \$100 monthly.

**Yard Crane Traveling Tower.** — An unusual yard crane has recently been put into service by the Cleveland Railway Co. in its new Harvard St. yard, to handle sand, coal, broken stone, etc., from and to storage piles, as described in *Eng. News*, June 15, 1916. It is a tower crane traveling on a straight track and equipped with a long cantilever jib carrying a traversing hoist from which a grab bucket is suspended.

Fig. 194a shows the structure of the crane quite clearly and

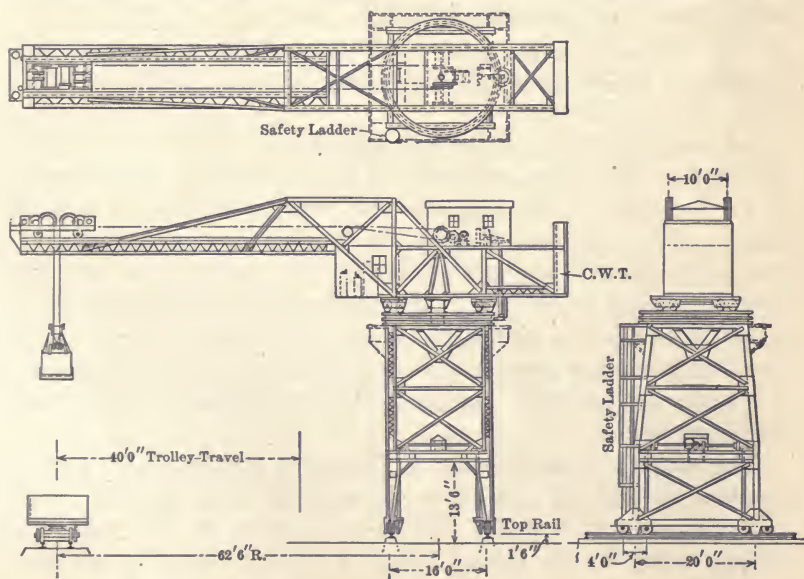

Fig. 194a. Traveling Cantilever Yard Crane, Cleveland Railways Co.

gives also the principal dimensions. The tower is carried by two 30-in. rolled-steel double-flanged wheels at each corner. The axle of one wheel of each pair is extended to take a bevel gear driven through shaft and gear connections by a motor just above the portal. The gear shaft nearest the motor carries a brake wheel, with brake shoes pressed against the wheel by springs and released by compressed air when the crane is to be moved.

The top of the tower carries a circular girder 18 ft. in diameter, on which are a rail and a rack circle. The cantilever is supported at four points on the rail by two 24-in. rolled steel wheels. It is rotated by a pinion on a vertical shaft extending from the rack up to the motor in the machinery house directly above. A manually operated brake controls the rotation. The trolley, a steel frame supported by four 16-in. cast-steel wheels, is designed for handling a  $2\frac{1}{2}$ -yd. grab bucket, maximum load about 15,000 lb. There are two 20"  $\times$  42" drums on the trolley, each driven by a geared motor; one drum handles the closing line and the other the two opening lines of the bucket. The two opening lines are attached to the bucket by an equalizer that holds them 24 in. apart. Equalizers at the ends of the trolley frame provide attachment for two pairs of ropes parallel to the track, leading to a motor-driven winding drum in the machinery house, by which the trolley is moved back and forth along the cantilever.

An operators' cab, placed just under the cantilever track and in front of the tower, contains all the controllers. This house is an inclosure of asbestos-covered corrugated steel on a steel frame. The floor is of wood. The machinery house, on top of the jib framework, containing the trolley travel and the rotating machinery and an air pump, is a corrugated-iron inclosure on a steel frame with a steel-plate floor. The crane-travel motor, over the portal, is protected by a hinged casing over the motor and brake mechanism. Similar casing is provided for the trolley hoist motors.

The general proportioning of the crane is such as to give a factor of stability of 2, with maximum load in the bucket. The motor equipment includes two 40-hp. motors on the trolley, a 10-hp. motor for the trolley travel, a 40-hp. motor for rotation

and a 40-hp. motor for the crane travel, all series wound. The hoist motors have disk magnetic brakes and are governed by magnetic control with dynamic braking; the other motors are handled by drum controllers.

The speeds of the machine are 160 ft. per min. hoist speed at maximum load; trolley travel, 300 ft. per min.; crane travel, 100 to 125 ft. per min.; rotation, 2 r.p.m.

**Track Scales.** — The track scale is not directly a revenue producer, but since weight is the basis of freight revenue, it is evident that the construction, installation and maintenance of scales is of great importance.

To keep pace with the rapid increase in the weight of cars and the paramount need of accurate results, track scales, for railway purposes, have received considerable attention and study on the part of the railway officials and the manufacturers during the past few years.

It is recognized that there are some essential features which must be obtained before the desired results can be achieved in scale weighing; some of these are as follows:

A rigid frame to support the track that will be strong enough to carry the load without appreciable deflection.

The scale irons must be of adequate construction so designed that the working unit stresses shall be as low as possible.

The scales must be so anchored as to prevent undue motion on the knife edges.

The use of bridge rails or extension ends at either end of the scale to transmit the load onto the scale gradually, without hammer or shock.

Track scales can be secured up to and including 400-ton capacity, but makers prefer when the weighing is over 150 tons to make each scale a special study.

The scales are usually placed between the receiving and separating yards, or on one side of the main yard, parallel with and next to the switching track convenient to the main line.

With the introduction of the steel car the use of wooden stringers for supporting scale platform has been virtually abandoned, having been replaced very largely by all-metal construction.

**Track Scales, Lake Erie.** — The dead rails are supported independent of the weighing mechanism on steel, 12-in. 40-lb. I-beams framed to cross girders. The main line rail girders are 24-in. 80-lb. I-beams, on which rest the cast pedestals that support the double rail beam track.

The main levers are of cast iron with 12-in. load and fulcrum pivots and 4½-in. tip pivots.

The main lever stands are placed directly on concrete foundation. The pit is large and is entered by a stairway from the scale office. The weighing beam is graduated by 20 lb. up to 2000 lb., with 50 lb. poise. Deck is built of steel plates resting on the walls of the pit rather than on the scale itself.

**C. P. R. Track Scale.** — Figs. 195 and 196 are known as the extra heavy type 100 and 150-ton capacity steel frame. The scale is constructed on a system in which a series of transverse

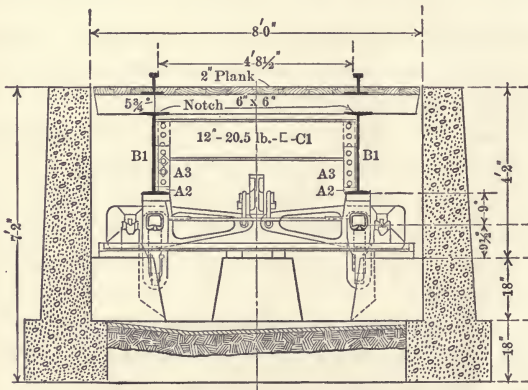

Fig. 195. Cross Section, C. P. R. Track Scale.

or main levers transmit the load to a line of longitudinal extension levers, which in turn transmit to the 5th lever and thence to the weighing beam. The main lever stands are set directly on the concrete foundation; the scale is equipped with steel transverse girders to support the dead rail so that the traffic over them in no way affects the weighing mechanism. The scale may be built level or on a 0.75 per cent grade if motion weighing is desired.

The foundations are of concrete and the main girders of steel; the main levers are of cast steel and the pivots and bearings of



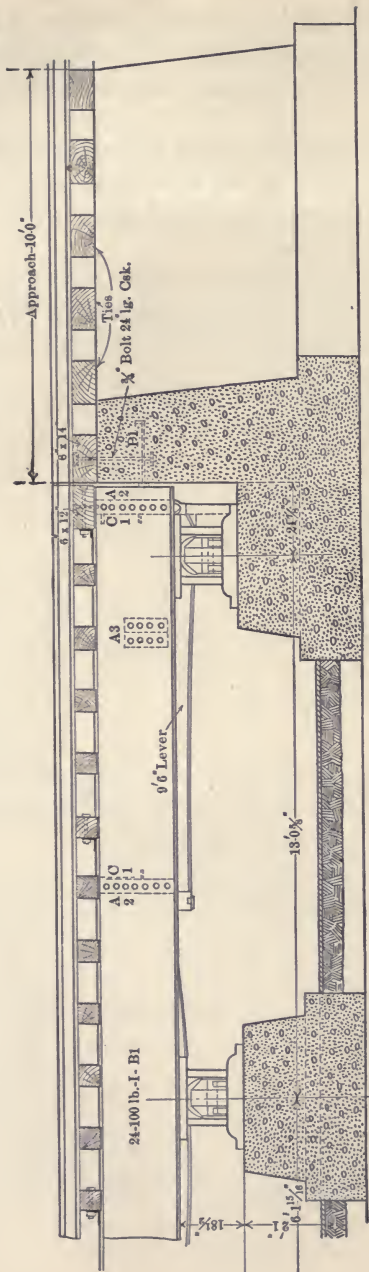

Fig. 196. Longitudinal Section, C. P. R. Track Scale.

special alloy steel and the weighing beam close grained cast iron. The deck is constructed of two thicknesses of  $1\frac{3}{4}$ -in. yellow pine, T. & G. planking, with a thickness of tar paper between layers.

The cost of the 100-ton track scale with 42-ft. platform is estimated at \$3750 and the 150-ton track scale with 50-ft. platform at \$8500. The various items from which the totals are arrived at are given below.

The following is an itemized estimate of the C. P. R. standard 100-ton track scale; extra heavy steel frame with 62-ft. pit and approach walls and 42-ft. weighing platform, no dead rail:

Excavation and backfill, 210 cu. yd. @ 75¢.....	\$ 157.50
Concrete foundation.....	888.00
Cinder filling.....	5.00
Cement floor.....	35.00
Lumber.....	105.00
One set 100-ton scale irons.....	1100.00
Steel frame for scale irons (10,250 lb.) @ 6¢.....	615.00
Labor erecting scales.....	200.00
Drainage.....	100.00
Painting.....	10.00
Freight, say.....	100.00
General hardware.....	5.00
Rail and fastening for 66 ft. of 85-lb. track.....	75.00
	<u>\$3395.50</u>
Supervision and contingencies.....	354.50
Total.....	<u>\$3750.50</u>

The 150-ton track scale is of very much heavier construction and has a pit 56 ft. by  $10\frac{1}{2}$  ft. and a weighing platform of 50 ft. The following is an itemized estimate:

Excavation and backfill, 300 cu. yd. @ 75¢.....	\$ 225.00
Concrete, 134 cu. yd. @ \$10.00.....	1340.00
Cinder filling.....	7.00
Cement floor.....	50.00
Lumber, 3000 F. B. M. @ \$50 per M.....	250.00
Set 150-ton scale irons.....	2100.00
Steel frame for scale irons, 47,462 lb. @ 6¢.....	2848.00
Labor erecting scales.....	250.00
Drainage.....	100.00
Freight.....	100.00
Rails, fastenings and switches.....	400.00
Painting.....	10.00
General hardware.....	100.00
	<u>\$7780.00</u>
Supervision and contingencies.....	720.00
Total.....	<u>\$8500.00</u>

**Scale Houses.** — Scale houses are usually constructed at track scales for proper housing and protection of scale beam and protection of weigh master, and where scale houses are not provided it is usual to box in the scale beam.

A C. P. R. shelter or scale house is shown, Fig. 197, constructed as follows:

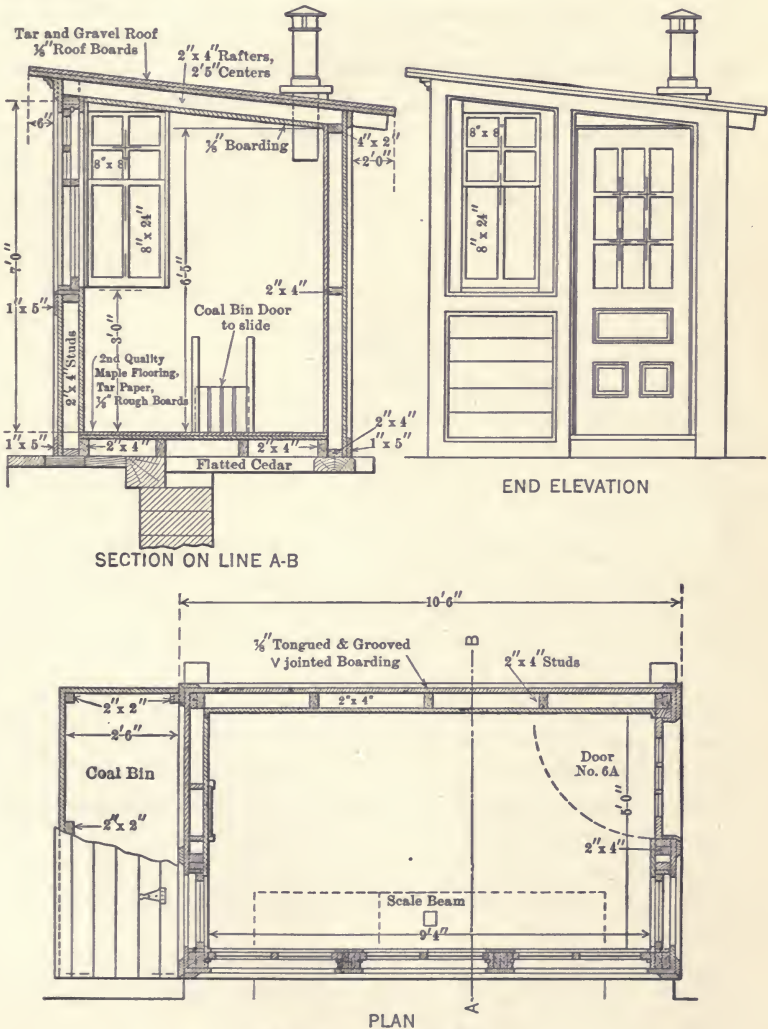

Fig. 197. Scale Shelter

The house itself rests partly on the pit walls so that there is little or no foundation to be provided. The ground sills are of 6-in. flattened cedar, and the studs 2" × 4"; the joists are also 2" × 4" including the rafters. The floor is built of  $\frac{7}{8}$ -in. T. & G. rough boards with  $\frac{7}{8}$ -in. dressed narrow flooring on top and a layer of building paper between. The roof is also double boarded and finished on top with tar and gravel or composition roofing. The interior is sheathed throughout with  $\frac{7}{8}$  narrow boards and the exterior is covered with novelty sheathing or siding boards. A small coal bin and chimney are provided.

The estimated cost of the scale house is as follows:

Timber, 1300 F. B. M. @ 40¢.....	\$ 52.00
Millwork.....	28.00
Hardware.....	3.00
Roofing and eaves.....	42.00
Painting, etc.....	25.00
Total.....	<u>\$150.00</u>

### Ice Houses.

Ice houses are generally framed structures built by the railway company to store ice at divisional, terminal, and other points convenient for storage and supply. The houses are stocked in winter, and the ice used for drinking purposes, etc., in office, car, freight, and general service.

For office and car service the ice is washed and broken up in the ice house, and trucked to the cars, etc. For refrigerator freight service a siding is generally placed close to the ice house, with an elevated platform running alongside, from which the ice is handled from house to car by trucks.

Ice-handling machinery for storing and handling blocks of ice either into or out of storage consists, if the quantity is small, of adjustable tackle hung from beams projecting over the doors, the doors being arranged in tiers to facilitate the handling of ice at different levels; when large quantities are handled, elevating and lowering machines on the endless chain, pneumatic, or brake principle are used which automatically dump the blocks at any level desired.

In estimating the capacity of ice houses, the height of storage is usually reckoned to the eaves, and a ton of ice will occupy from 40 to 45 cu. ft. of space.

*Construction.* — To avoid shrinkage as much as possible, stone or concrete foundations should be used for the outer walls; ordinary wood sill foundation is not sufficient to prevent heat penetrating through the outside ground to the floor in summer.

The outer walls and roof should be insulated with at least three coverings of board and two air spaces, and a vent should extend the full length of roof.

The house should be divided up into a number of compartments, the cross partitions serving to tie in the main walls instead of iron rods; it also serves to lessen the exposure of ice to warm air when ice is going out; it divides the house into so many units, and one unit only is exposed when handling.

The floor should slope slightly both ways to the center of the house and be well drained, the drain having a water seal and vent when possible.

*Cutting, Storing, and Handling.* — No doubt the method of cutting, storing, and handling the ice has a great deal to do with obtaining results. Outer doors should be used only when filling the house, and inner doors for removing; working always to one main outlet rather than to a series of outlets. All ice should have snow caps planed off before storing, and the blocks cut to a size easily handled; 100 lb. or thereabout, 10 to 14 in. thick, is recommended.

When storing, a space should be left all around each block, so that it may not be necessary to hack and break the ice too much when removing. For quick and easy handling ice machines should be used rather than slides or block tackle, to avoid waste and to deliver the ice in good condition.

*Cost.* — Ordinary frame structures, cedar sill foundation, insulated walls, two air spaces and three boards, insulated partitions and roof with louver ventilators, and 1-in. rough hemlock board floor, on a cinder bed as per Fig. 198, will cost approximately \$3 to \$4.50 per ton capacity, or 7 to 10 cents per cubic foot.

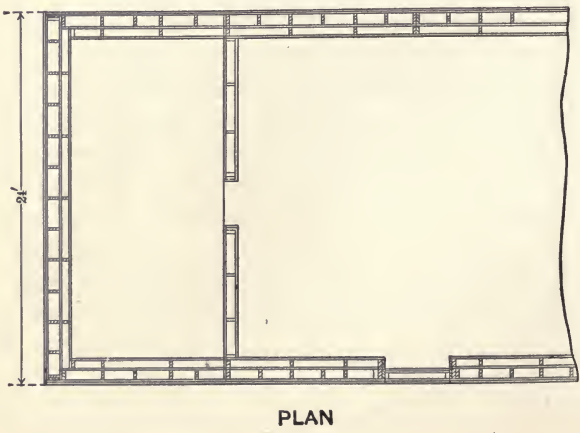
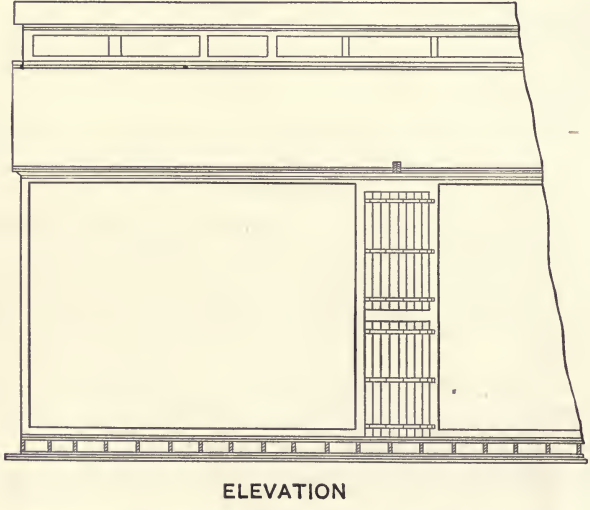
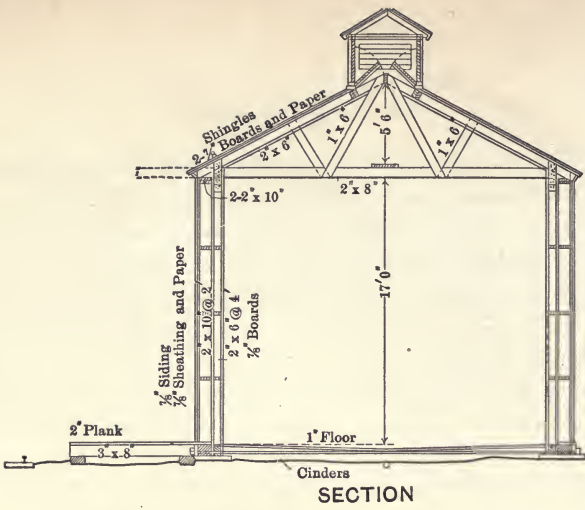

## APPROXIMATE COST OF VARIOUS SIZES OF ICE HOUSES.

	Wood foundations.	Masonry foundations.
250-ton ice house 24 feet wide by 36 feet long by 18 feet high to eaves.....	\$950	\$1,300
500-ton ice house 24 feet wide by 72 feet long by 18 feet high to eaves.....	1850	2,500
1000-ton ice house 30 feet wide by 84 feet long by 20 feet high to eaves.....	3350	4,000
2000-ton ice house 30 feet wide by 168 feet long by 20 feet high to eaves.....	6650	7,800
3000-ton ice house 30 feet wide by 252 feet long by 20 feet high to eaves.....	9950	11,500

## APPROXIMATE ESTIMATE FOR A 250-TON ICE HOUSE. (Fig. 198.)

Quantities.	Material.	Labor.	Total unit.	Cost.
20,000 ft. B. M. lumber, per thousand.....	\$18.00	\$17.00	\$35.00	\$700.00
Doors.....	25.00	10.00	....	35.00
Hardware.....	25.00	15.00	....	40.00
Paint.....	34.00	40.00	....	74.00
Cinders and drain.....	....	....	....	18.00
				\$867.00
Supervision and contingencies.....				83.00
				\$950.00
If masonry foundation, add.....				350.00
Total.....				\$1300.00

**Small Ice Houses on the N. Y. C. & H. R. R.** — The ice houses at North Rose and Model City represent houses of smaller capacity than have been built recently. The size of rooms is 48' × 28' × 24' high with a capacity of 735 tons. Some of the houses are 33' × 32' × 24' high with a capacity of 500 tons.

The foundations are posts, or they may be old bridge ties, but concrete is sometimes used and is preferable. The floors are of 2-in. hemlock plank on 18 in. of cinders. Plank should be spiked to the cedar sleepers for which old bridge stringers or old car sills may be used.

Beginning at the outside, the walls consist of siding, sheathing paper, a 2-in. air space, sheathing paper, 1-in. hemlock, an 8-in. air space, 1-in. hemlock, sheathing paper, a 2-in. air space,

sheathing paper and 1-in. hemlock. In some cases the larger air space is empty, and in others it is filled with shavings. The outside 2-in. air space is ventilated. The partitions consist of studding sheathed with 1-in. hemlock, leaving a 10-in. space which is filled with shavings or sawdust if desired. The ceiling is built with rafters ceiled on the under side, or ceiling joists ceiled on top. In some cases the latter is covered with 14 in. of shavings or sawdust, and in other cases not. In the Pennsylvania division houses no ceiling was placed, but the roof was insulated by one-ply tar paper and ceiling on the under side of the rafters, while the space to the top of rafters was filled with shavings and then tongue-and-groove roof sheeting, finished with some type of prepared felt roofing. The space under the roof in all houses is well ventilated, in the cheaper houses by louvers in each end, and in the better houses by 6' × 8' ventilators along the roof, and by doors or louvers in each end of the house.

On the latest houses the platforms are 6 ft. wide, and are supported by brackets on the side of the house. On the Pennsylvania division houses the platforms are 4 ft. 8 in. wide, and are supported by piers. No conveyors are used on the smaller houses. Elevators operated by steam or electricity are used. The gig used on the St. Lawrence division will handle four cakes per minute; most of the installations will handle about two cakes per minute. Natural ice exclusively is handled and stored. The standard size of cakes is 22" × 32" × 10 to 24" thick. No standard is adopted, but ice is stored flat in most houses and as compact as possible. A cavity of 6 or 8 in. is left between the ice and the wall, while the space between the ice and the ceiling is 2 to 3 ft. A heavy covering of sawdust is placed on top of the ice, and sometimes between the ice and the wall. Swamp hay is preferable to sawdust. Nothing of any kind is used between layers.

No standard method is adopted in removing the ice. In some cases it is lowered in all rooms uniformly, and in others one room is emptied before working another.

In some cases seepage is found to be entirely sufficient to provide drainage. In others blind drains or tile drains are provided, but they are arranged so that air currents cannot enter the house.



In some cases the floor is placed a little higher than the adjacent ground. The sub-grade of the floor should be sloped  $\frac{1}{2}$  in. in 1 ft. to carry the water to the center.

The shrinkage is estimated at about 10 to 12 per cent. At some houses where cars are iced daily with ice brought to the platforms some time-in advance, the loss may reach as high as 40 per cent.

*Cost.* — Two houses, built for North Rose and Model City, cost as follows:

2200 tons capacity; total cost \$5538, or \$2.51 per ton.

2200 tons capacity; total cost, \$4730, or \$2.14 per ton.

The following data apply to two houses built on the St. Lawrence division in 1912 and 1913:

1500 tons capacity; total cost, \$5742, or \$3.83 per ton.

1500 tons capacity; total cost, \$5092, or \$3.39 per ton.

**Ice Storage Houses on the N. Y. C. & H. R. R.** — The three best equipped houses are fairly uniform in construction but vary in size. These houses are 60 ft. wide, and 120 to 240 ft. long. They are located so that additional rooms can be added in the future. The inside dimensions of the bays are 38' 9"  $\times$  57' 6"  $\times$  36' high with a capacity of 1700 tons each.

The foundation and partition walls are of concrete. The foundations under the floors consist of 12 in. of cinders, well tamped.

The floors are of 2-in. plank spiked to sleepers for which old 8'  $\times$  10' bridge ties, old car sills or other timbers may be used. There has never been any insulation other than the foundation of cinders, and it is not thought essential if proper foundation walls are used.

Beginning at the outside the walls and partitions consist of: siding, sheathing paper, 2-in. live air space, sheathing paper, 1-in. hemlock, 10-in. air space, 1-in. hemlock, sheathing paper, 2-in. air space, sheathing paper and 1-in. hemlock. The standard construction up to 1913 called for sawdust or shavings to be used in the exterior walls of houses, but during the last two or three years nothing has been used between studding in the 10-in. space. The 2-in. outside air space has an opening back of the water table which extends the entire height to about 8 ft. up to the rafters and opens into the attic. Interior partitions

are of 1-in. sheathing on each side of the studding giving a 10-in. air space. No paper is used.

The ceiling is entirely floored over, and 18 to 24 in. of shavings are placed on the top. Experience seems to question the advisability of this plan for several reasons: (1) Floor joists and flooring rot out in about six years, and renewals are very expensive: (2) much space is lost because workmen cannot pack ice within 3 ft. of the ceiling, thus necessitating a house 3 ft. higher than would otherwise be the case for a given tonnage: and (3) ice would really keep better if the ceiling were omitted and the roof insulated instead, and the ice covered with 12 in. of swamp hay. Under this plan it is believed the shrinkage would be much less.

The attic and roof are well aired by large ventilators set on the ridge of the roof, and by a door at each end of the house. The gable roof is ceiled on the under side of the rafters to a point where the distance from the attic floor to the roof is 2 ft. In case the ceiling of the house is omitted the under side of the rafters should be entirely ceiled and the space filled with shavings. A ventilator should be placed over each bay.

The doors are 9 in. thick with a clear width of 3 ft. 6 in.; they contain one air space and one space filled with shavings.

A platform is suspended against one or both sides of the house carrying an endless chain conveyor, which is lowered or raised according to the height of the ice in the rooms being worked. A long platform 14 ft. 6 in. above the base of rail is provided for icing cars, and the short platform below is for filling the house.

The "Gifford-Wood" conveyors are used, the motive power being electricity. The conveyor on a suspended gallery is reversible to fill or empty the house. Where the conveyor of the suspended gallery joins the icing platform, men are stationed to push the cakes to conveyors running each way along the platform along that point. From 5 cakes per minute for the oldest house of this type to 12 cakes for the newest can be handled. From 25 to 30 cars per day can be stowed with a force of 45 men. The ice averages 25 to 28 tons per car. All ice comes by railroad and is packed as closely as possible. The standard size of cakes is 22" × 32" × 12 to 24" thick. A

thickness of 12 in. is preferred, as handling 24-in. ice costs more in the end. The ice comes out better and with less breakage when stored on edge, but it can be more easily and quickly packed when laid flat. The practice in this respect is not uniform. The cakes are placed in contact as solidly as possible. No space between the ice and the wall is necessary with houses of this design.

The space between the ice and the ceiling is 3 to 4 ft. because it is impossible to work in less space. The ceiling may well be omitted to avoid this. No insulation for the ice is provided. No wood is used between layers for natural ice, but this is necessary for artificial ice to prevent freezing together.

No sawdust is placed between layers. At railroad houses ice is not well cleaned when removed, and the sawdust makes a bad mess. In refrigerator cars it causes trouble by clogging the drip pipes. Cork is too expensive, in addition to its being a nuisance like sawdust. If the construction of the house requires a covering, swamp hay is the best material as it can be used several times. The top layer of ice is always covered, and it is not as dirty as sawdust and shavings. There is no difference in methods of handling for a short busy season and a long slow one for conditions which vary from a few cars per day in the spring and summer to 200 cars per day in the fruit season.

The sub-grade and floor of each room are sloped  $\frac{1}{2}$  in. per foot to the center. A 6-in. tile drain is provided for each room extending from the catch basin at the bottom of the cinders. In a good percolating soil, however, a drain is not necessary. There must be a trap in the drain to prevent the entrance of air.

For houses kept closed the shrinkage will average 15 per cent; with doors open more or less of the time this will amount to 25 per cent; doors open most of the time will result in a loss of 50 per cent or more. With doors carefully supervised and good swamp hay covering, shrinkage should not exceed 10 or 15 per cent. Ice is drawn before or after arrival of trains depending on operating conditions. In busy times conveyors are constantly at work.

*Cost.* — The cost of the 69'  $\times$  240' house, with six rows and a capacity of 10,000 tons, including platforms and machinery (but not tracks) at Rochester, built in 1913, was \$60,000 or \$6

per ton. The house at Oswego, built in 1913, 60'  $\times$  120' with three rooms and a capacity of 5000 tons, cost \$25,177 or \$5.05 per ton. The former has very long platforms, with a total length of 1800 ft. extending beyond the end of the house on each side. The latter house has shorter platforms, with a total length of 1500 ft. on one side only, thus having only half the outfit of motor and hoisting machinery, and a little more than one-fourth of the conveyor chain.

**Concrete Ice House on the Northern Pacific.** — The Northern Pacific ice house at Pasco is 483 ft. long, 94 ft. 6 in. wide and 41 ft. 10 in. high to the roof and has a storage capacity of 30,000 tons. (Fig. 199.)

It is divided into 12 bays by insulated walls. The main walls and partitions consist of two 4-in. concrete reinforced walls cast with a 10-in. space between them, which is filled with fine regranulated cork for insulation.

The floor is made of 4-in. reinforced concrete laid on 16 in. of cinders well tamped for insulation and drained. The floor is sloped from all four sides to the center of each bay to provide drainage and give the ice a tendency to tip away from the walls. On the inside of all walls, 2"  $\times$  4" timbers, 2 ft. 6-in. centers, are bolted vertically and 1"  $\times$  4" beveled boards nailed horizontally to keep ice and drippings away from walls.

The ceiling is of the beam and slab type, reinforced concrete 4-in. thick. On top of ceiling slab 2"  $\times$  6" timbers are placed 3-ft. centers and the space between is filled with fine regranulated cork giving 6-in. of insulation.  $\frac{7}{8}$ -in. boards are nailed to the 2"  $\times$  6" and covered with two layers of oil paper, on top of which is placed 1 $\frac{1}{2}$  in. cement mortar reinforced with wire netting.

The roof is of reinforced concrete supported on Warren roof trusses and covered with tar and gravel.

The cupolas built along the center of the building are provided for ice chutes and elevator machinery. The frame is of steel and the walls of hard burned tile in cement mortar, excepting the parts carrying the elevator machinery which is of hard burned brick. The roof is of reinforced concrete similar to the main roof.

Each bay is provided with an elevator, 2000 lb. capacity,

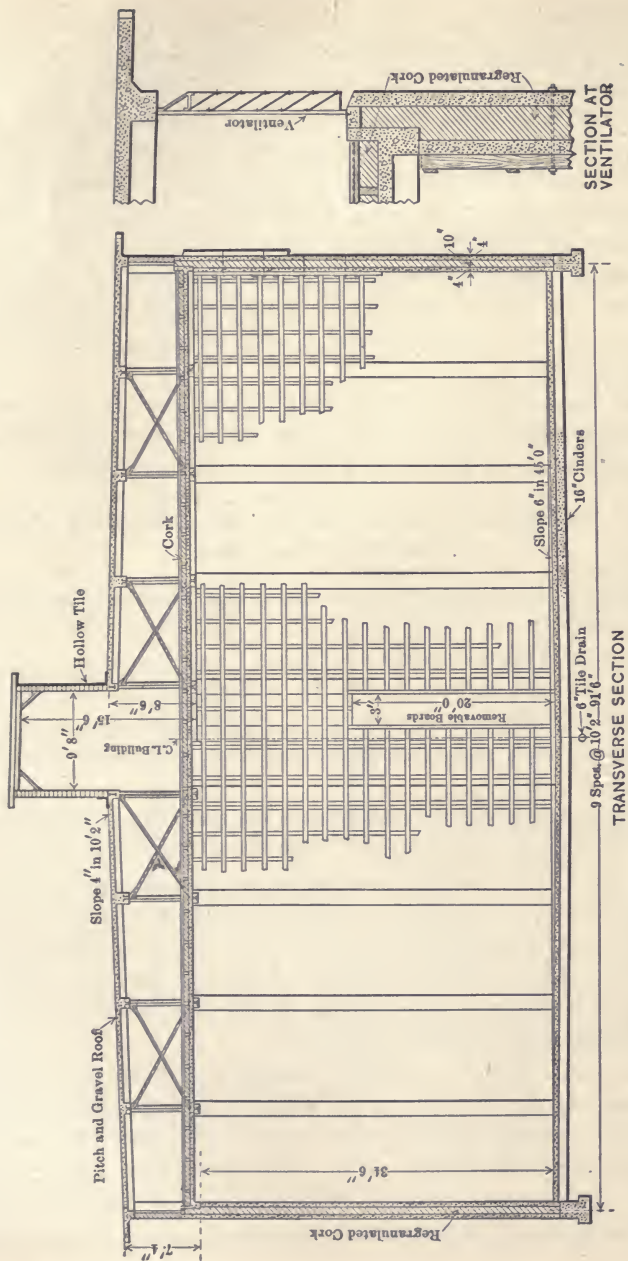

Fig. 199. Section Through Northern Pacific Ice House Showing Cork Insulation.

operated by an electric hoist and is constructed of steel and designed to unload ice automatically into the chute at the top of the building. One door is provided for each bay for filling purposes; each division wall has a door 3 ft. wide by 20 ft. high located about the center. The outside doors are double and are made of four thicknesses of  $\frac{3}{4}$ -in. boards — two on the inside and two on the outside, with  $2\frac{1}{2}$  in. air space between. Two layers of waterproof paper are laid between the boards. The doors are hung on heavy strap iron combination hasps and hinges, and all edges covered with rubber canvas  $\frac{1}{8}$  in. thick on a cushion of hair. The outside of the doors is covered with galvanized steel.

Estimating 10 cents a cubic foot as the cost of a house of this character and size, the price would be in the neighborhood of \$193,000 or about \$6.50 per ton of ice storage capacity.

#### **Cost of Ice Storage Houses and Ice Manufacturing Plants for Railway Purposes.**

It is a foregone conclusion that any house built for the storage of ice cannot be so constructed that some shrinkage will not take place in the ice stored.

How much the shrinkage will be depends upon the class of house built, how it is designed and insulated and also to a very large degree with what care it is looked after and operated when in use.

On the assumption that the greater the cost the more efficient will be the house, the amount to spend for a storage house will depend primarily upon the price at which ice can be purchased and also, to some extent, on the total amount consumed.

In southern countries, where the cost of ice is high, it will pay to put up an expensive house to conserve the ice; whereas in northern latitudes where ice can be obtained at a low rate, a much cheaper house is quite justified.

On the other hand, there is a point where storage houses would not be as economical as an ice manufacturing plant; where one leaves off and the other begins is a matter that cannot always be solved by figures alone. The economics may not be the final figured cost per ton of ice stored or manufactured, but rather the local factors, such as ground space, power avail-

able, labor, teaming, car refrigeration, passenger and public service, peculiar to each location, also a possible loss of revenue.

When working out the economics as to whether it will pay to purchase ice during the winter and store same, instead of making a contract with some ice company, there are a number of items to be considered.

The first would be the cost and construction of the storage house, which may range from \$2.50 to \$7.50 per ton of ice stored, but to make a comparison the following three types of ice storage houses will be considered:

*Cost of three types of ice storage houses.*

- No. 1. C. P. R. ice house, Fig. 200, sill foundation estimated shrinkage 40 per cent, will cost per ton stored. . . . \$3.50
- No. 2. C. P. R. ice house, Fig. 200, concrete foundation, estimated shrinkage 25 per cent, will cost per ton stored. . . . 5.00
- No. 3. N. P. R. ice house, Fig. 199, concrete foundation, estimated shrinkage 15 per cent, will cost per ton stored. . . . 6.50

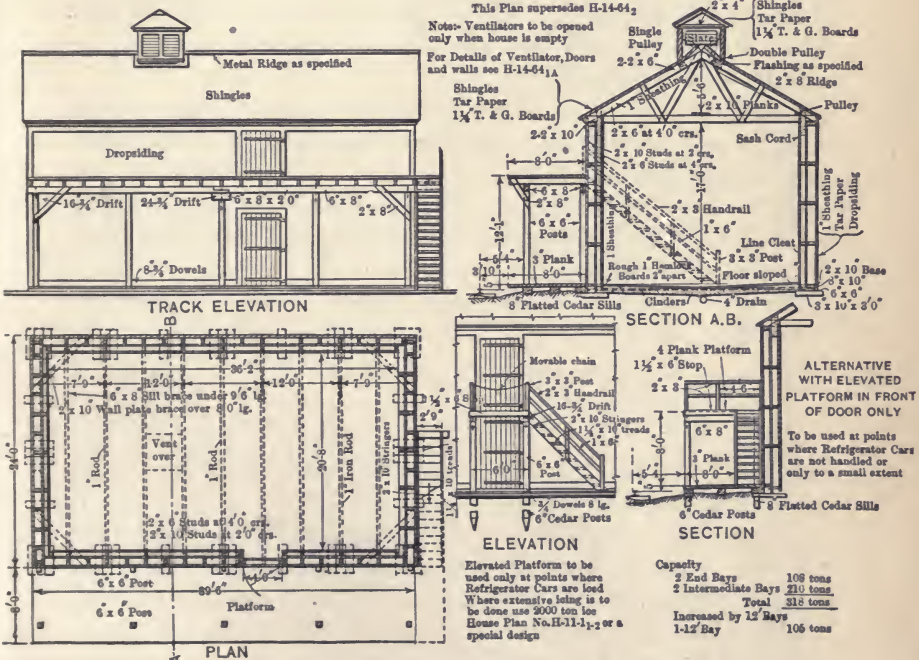

Fig. 200. C. P. R. Standard No. 2 Ice House.

In order to compare the above houses on a ton basis of ice consumed, the shrinkage has to be added; the figures will therefore be:

		Per Ton Consumed.
No. 1.	\$3.50 plus 40 per cent.....	\$4.90
No. 2.	\$5.00 plus 25 per cent.....	6.25
No. 3.	\$6.50 plus 15 per cent.....	7.47½

The latter figures, therefore, represent the investment per ton of ice consumed. To this should be added, on the same tonnage basis, the cost of the land on which the house is to be built; generally the house is located on the railway company's property that is available, and is seldom considered in the cost; it will be omitted in this discussion.

There is also the question of trackage to be considered depending upon the facilities that may be required to handle not only the ice from car to storage, but the icing of cars as well. So far as the railway company is concerned, this is seldom figured in the cost as it is considered that track has to be provided in any case whether the ice is bought by contract or brought in to be stored.

*Fixed charges.* — The fixed charges, such as interest on the money spent to build the house, including taxes, insurance, maintenance and depreciation, have next to be considered; the interest on the investment may be taken at 6 per cent and the taxes, insurance, maintenance and depreciation at 4 per cent or a total of 10 per cent.

The fixed charges for the three houses under consideration would therefore be:

		Per Ton Used.
No. 1.	10 per cent on \$4.90.....	\$0.49
No. 2.	10 per cent on \$6.25.....	0.62½
No. 3.	10 per cent on \$7.47½.....	0.74½

To the fixed charges has to be added the cost of harvesting the ice and the handling of it.

*Cost of Ice.* — The cost of ice harvested during the winter will vary at each location, depending upon the facilities and natural advantages that may be available, transportation, length of haul, etc., and will vary from 20 cents to \$1 per ton, or more, if it has to be transported in cars to the ice storage house, which usually is the case.



Supposing that it costs 80 cents per ton f. o. b. cars at store house we would have the following comparison for the three cases being considered, per ton of ice consumed.

	Per Ton Consumed.
1st. 80¢ plus 40 per cent for shrinkage.....	\$1.12
2nd. 80¢ plus 25 per cent for shrinkage.....	1.00
3rd. 80¢ plus 15 per cent for shrinkage.....	0.92

*Removing Ice from Cars to Storage.* — The cost of removing ice from cars to storage varies from 25 cents to 55 cents per ton and covers cleaning the house, boarding up doors, looking after hoists, slings, etc., and covering over the ice. An average price for estimating would be 40 cents per ton. For the three cases under consideration, the cost per ton of ice consumed would be:

1st. 40¢ plus 40 per cent for shrinkage.....	\$0.56
2nd. 40¢ plus 25 per cent for shrinkage.....	0.50
3rd. 40¢ plus 15 per cent for shrinkage.....	0.46

A summary or table can now be made of the various charges for the three types of ice storage houses, as follows:

TABLE 102. — COST PER TON OF ICE CONSUMED.  
(For varying conditions, figuring ice can be purchased at 80 cents per ton.)

	No. 1	No. 2	No. 3
<i>Investment:</i>			
Kind of house.....	No. 1	No. 2	No. 3
Percentage of shrinkage.....	40%	25%	15%
Cost of building, per ton.....	\$3.50	\$5.00	\$6.50
Add, per ton, for shrinkage.....	1.40	1.25	0.97½
Cost per ton consumed.....	\$4.90	\$6.25	\$7.47½
<i>Fixed charges:</i>			
Interest on investment 6%	\$0.49	\$0.62½	\$0.75
Taxes, insurance, maintenance and depreciation } 4%			
Cost of ice at 80¢ per ton put into cars, or direct into storehouse with shrinkage added.....	1.12	1.00	0.92
Cost per ton consumed if stored direct.....	\$1.61	\$1.62½	\$1.67
If ice has to be handled from cars to storage, add (including shrinkage).....	0.56	0.50	0.46
Cost per ton consumed when shipped in cars.....	\$2.17	\$2.12½	\$2.13
If ice has to be handled from storage to refrigerator cars, add.....	0.30	0.30	0.30
Cost per ton consumed, when shipped, stored and handled to refrigerator cars.....	\$2.47	\$2.42½	\$2.43

From the foregoing figures it will be noted that with ice at 80 cents per ton, a No. 1 house is the most economical when ice is placed direct into storehouse; and No. 2 when the ice has to be shipped. It shows that ice at 80 cents per ton, handled

in cars, is high enough to warrant a type of house that will conserve the shrinkage and reduce the amount to be shipped.

As a comparison, and to ascertain approximately how the figures run for ice varying from 10 cents to \$1.20 per ton, the equivalent costs for the three following conditions are shown on Table 103.

1st. Cost per ton of ice consumed when stored direct.

2nd. Cost per ton of ice consumed when shipped and stored.

3rd. Cost per ton of ice consumed when shipped, stored and supplied to refrigerator cars.

TABLE 103. — EQUIVALENT COST PER TON OF ICE CONSUMED FOR VARYING CONDITIONS, FIGURING THE COST OF ICE FROM 10 CENTS TO \$1.20 PER TON.

No. 1 ice house 40% shrinkage.

Cost of ice per ton delivered.....	\$0.10	\$0.20	\$0.30	\$0.40	\$0.50	\$0.60	\$0.80	\$1.00	\$1.20
Cost per ton plus 40% shrinkage....	0.14	0.18	0.42	0.56	0.70	0.84	1.12	1.40	1.68
Fixed charges on investment.....	0.49	0.49	0.49	0.49	0.49	0.49	0.49	0.49	0.49
Cost per ton stored direct.....	\$0.63	\$0.67	\$0.91	\$1.05	\$1.19	\$1.33	\$1.61	\$1.89	\$2.17
Handling ice from cars to storage with shrinkage added, per ton....	0.56	0.56	0.56	0.56	0.56	0.56	0.56	0.56	0.56
Cost per ton shipped in cars and stored.....	\$1.19	\$1.23	\$1.47	\$1.61	\$1.75	\$1.89	\$2.17	\$2.45	\$2.73
Handling ice from storage to refrigerator cars, per ton.....	0.30	0.30	0.30	0.30	0.30	0.30	0.30	0.30	0.30
Cost per ton shipped in cars, stored and supplied to refrigerator cars..	\$1.49	\$1.53	\$1.77	\$1.91	\$2.05	\$2.19	\$2.47	\$2.75	\$3.03

No. 2 ice house 25% shrinkage.

Cost of ice per ton delivered.....	\$0.10	\$0.20	\$0.30	\$0.40	\$0.50	\$0.60	\$0.80	\$1.00	\$1.20
Cost per ton plus 25% shrinkage....	\$0.12½	\$0.25	\$0.37½	\$0.50	\$0.62½	\$0.75	\$1.00	\$1.25	\$1.50
Fixed charges on investment.....	0.62½	0.62½	0.62½	0.62½	0.62½	0.62½	0.62½	0.62½	0.62½
Cost per ton stored direct.....	\$0.75	\$0.87½	\$1.00	\$1.12½	\$1.25	\$1.37½	\$1.62½	\$1.87½	\$2.12½
Handling ice from cars to storage with shrinkage added, per ton....	0.50	0.50	0.50	0.50	0.50	0.50	0.50	0.50	0.50
Cost per ton shipped in cars and stored.....	\$1.25	\$1.37½	\$1.50	\$1.62½	\$1.75	\$1.87½	\$2.12½	\$2.37½	\$2.62½
Handling ice from storage to refrigerator cars, per ton.....	0.30	0.30	0.30	0.30	0.30	0.30	0.30	0.30	0.30
Cost per ton shipped in cars, stored and supplied to refrigerator cars..	\$1.55	\$1.67½	\$1.80	\$1.92½	\$2.05	\$2.17½	\$2.42½	\$2.67½	\$2.92½

No. 3 ice house 15% shrinkage.

Cost of ice per ton delivered.....	\$0.10	\$0.20	\$0.30	\$0.40	\$0.50	\$0.60	\$0.80	\$1.00	\$1.20
Cost per ton plus 15% shrinkage....	\$0.11½	\$0.23	\$0.34½	\$0.46	\$0.57½	\$0.69	\$0.92	\$1.15	\$1.38
Fixed charges on investment.....	0.75	0.75	0.75	0.75	0.75	0.75	0.75	0.75	0.75
Cost per ton stored direct.....	\$0.86½	\$0.98	\$1.09½	\$1.21	\$1.32½	\$1.44	\$1.67	\$1.90	\$2.13
Handling ice from cars to storage with shrinkage added, per ton....	0.46	0.46	0.46	0.46	0.46	0.46	0.46	0.46	0.46
Cost per ton shipped in cars and stored.....	\$1.32½	\$1.44	\$1.55½	\$1.67	\$1.78½	\$1.90	\$2.13	\$2.36	\$2.59
Handling cars from storage to refrigerator cars, per ton.....	0.30	0.30	0.30	0.30	0.30	0.30	0.30	0.30	0.30
Cost per ton shipped in cars, stored and supplied to refrigerator cars..	\$1.62½	\$1.74	\$1.85½	\$1.97	\$2.08½	\$2.20	\$2.43	\$2.66	\$2.89

From the foregoing Table 103, it would appear that when ice, stored direct, can be purchased for 80 cents a ton, or less, the No. 1 house is quite suitable; above 80 cents to \$1.20 the No. 2 house, and over \$1.20 the No. 3 house; and when the ice shipped in cars to the storehouse can be purchased for 50 cents, or less, the No. 1 house is the one to adopt; and from 60 cents to \$1 per ton, the No. 2 house; and above \$1 per ton the No. 3 house.

**Ice Manufacture.** — In the manufacture of ice, the plant to select will depend, to a large extent, on local conditions, power available, facilities for handling and icing cars without extra service, etc.; obviously the larger the plant, the less will be the comparative cost per ton.

Table 104 gives the investment, cost of operation and capacity of plants ranging from 15 tons to 50 tons in 24 hours, for the ordinary run of railway installations. The figures are fairly liberal because it is recognized that a plant of this character requires good supervision and careful management; where carelessness creeps in and cheap labor is employed, the plant will depreciate and the maintenance charges are likely to be very high.

It may be noted that where cheap electric power is available the cost of electric plants as against steam will be 10 to 20 per cent less than the figures stated.

Comparing the cost per ton when manufactured with the cost per ton when stored, as given in Table 103, always provided that the quantity for each mechanical plant under consideration will actually be required, the figures would be about as follows:

15 ton plant will be cheaper than storing when ice is costing \$1.10 per ton or more.

25 ton plant will be cheaper than storing when ice is costing 70 cents per ton or more.

40 ton plant will be cheaper than storing when ice is costing 45 cents per ton or more.

50 ton plant will be cheaper than storing when ice is costing 35 cents per ton or more.

It is obvious that any mechanical plant that is not worked up to its capacity or is too large for actual needs will run up the cost per ton to much higher figures than those given.

TABLE 104. — APPROXIMATE COST OF ICE MANUFACTURE INCLUDING INVESTMENT, COST OF OPERATION AND COST PER TON. (STEAM OR ELECTRIC EQUIPMENT.\*)

Capacity in tons per 24 hours..... Capacity in tons yearly (for 240 days).....	15 tons. 3600 tons.	25 tons. 6000 tons.	40 tons. 9600 tons.	50 tons. 12,000 tons.
<i>Investment:</i>				
Building and land.....	\$7,500	\$11,875	\$14,000	\$17,000
Mechanical equipment.....	13,000	18,125	27,000	33,000
Total investment.....	\$20,500	\$30,000	\$41,000	\$50,000
<i>Daily operating expenses:</i>				
Engineers, 2.....	\$7.00	\$7.00	\$7.00	\$7.00
Tankmen, 2.....	4.50	4.50	4.50	4.50
Firemen, 2.....	4.50	4.50	4.50	4.50
Storeman, 1.....	.....	.....	2.25	2.25
Coal at \$3.00 per ton or electric current at $\frac{1}{2}$ ¢ kw.-hr.....	5.00	7.50	12.50	15.50
Ammonia, oil, waste.....	2.00	3.50	4.25	5.25
Records and stationery.....	1.00	2.00	3.00	4.00
Cost of operation (daily).....	\$24.00	\$29.00	\$38.00	\$43.00
Cost of operation on basis of running the plant full operation, 240 days..	\$5,360	\$6,960	\$9,120	\$10,320
All labor expense for balance of year..	1,070	1,317	1,700	2,360
<i>Interest on investment:</i>				
Building and mechanical equipment, 6%.....	1,230	1,800	2,460	3,000
Depreciation, insurance, taxes, etc., building, 4%.....	300	474	560	680
Depreciation on mechan'l equip., 8%.....	1,040	1,449	2,160	2,640
Total yearly expense.....	\$9,000	\$12,000	\$16,000	\$19,000
Cost per ton of ice produced.....	\$2.50	\$2.50	\$1.67	\$1.58
Cost per ton if supplied to refrig. cars..	\$2.80	\$2.30	\$1.97	\$1.88

\* When electric power can be obtained at a low rate, the cost per ton with electrical equipment will be from 10 to 20 per cent less than the above figures.

NOTE. — No tracks are included in the above costs.

The foregoing table would indicate that the larger plants are much more economical than the smaller ones, provided that the machines are used to their full capacity. Some of the difference is also due to the fact that supervision and labor does not run in proportion to the increase in capacity.

**Comparative Costs for Large Commercial Ice Manufacturing Plants.** — The initial and operating costs of large ice plants ranging from 100 to 500 tons capacity per day of 24 hours, by Robert P. Kehoe, which are given in Table 105, may be taken as a guide in the determination of the advantageous kind of plant to install when such large installations are considered. The cost of the property is not included, which, of course, will vary with the location and, if desirable, an amount to cover this item may be added to the investment.

Evaporators and automatic stokers have been covered in the first cost of the steam-driven plants.

An average economy of 9 tons of ice per ton of coal has been assumed which is the usual working basis.

The price of oil has been taken as 3½ cents per gallon and a 1 cent rate per kilowatt-hour for electric current because any higher price could not be considered: even at this price it does not compare favorably with either the oil-engine driven or steam plant. The average electric-driven plant will be found to use 60 kw.-hr. per ton of ice.

The yearly load factor of 60 per cent is equivalent to 216 days of full operation. This would mean about 4 months of full operation, four months at half capacity and four months at one quarter capacity. In large plants in cities of considerable size these conditions usually exist, for commercial operation.

The capacity of the plants are given in tons of ice per twenty-four hours, and only one type is considered for three different kinds of motive power, using 300-lb. cans. A summary of the detailed figures are as follows:

Capacity per 24 hrs.	Cost of ice per ton.		
	Steam.	Electric.	Oil, etc.
100 tons	\$1.40	\$1.55	\$1.19
200 "	1.21	1.40	1.03
300 "	1.17	1.33	0.97
400 "	1.13	1.30	0.94

TABLE 105. — INVESTMENT, DAILY AND YEARLY COST OF OPERATION OF LARGE ICE PLANTS.

Capacity in tons of ice per 24 hr. ....	100 tons.			200 tons.		
Type of plant (all 300 lb. cans).....	Distilled water.	Raw water.		Distilled water.	Raw water.	
Motive power.....	Compound condensing steam engines.	Electric motors.	Oil engines.	Compound condensing steam engines.	Electric motors.	Oil engines.
<b>Investment:</b>						
Mechanical equipment complete.....	\$62,000	\$52,000	\$70,000	\$119,000	\$99,000	\$135,000
Building.....	37,500	35,000	35,000	65,000	60,000	60,000
Total investment (excluding land)....	\$99,500	\$87,000	\$105,000	\$184,000	\$159,000	\$195,000
Daily operating expense:						
Chief engineer.....	\$6.00	\$5.00	\$6.00	\$7.00	\$6.00	\$7.00
Assistant engineers, 1.....	3.50	3.50	3.50	(1) 4.00	4.00	4.00
Oilers, 2.....	4.00	4.00	4.00	(2) 4.00	4.00	4.00
Firemen, 2.....	4.00			(2) 4.50		
Tankmen, 4.....	8.00	(6) 12.00	12.00	(8) 16.00	(12) 24.00	24.00
Storehouse men, 2.....	4.00	4.00	4.00	(2) 4.00	4.00	4.00
Other labor.....				(2) 4.00	(1) 2.00	2.00
Fuel, coal at \$3.50 per ton, oil at 3½¢ per gal., current at 1¢ per kw.-hr.....	38.50	60.00	15.00	77.00	120.00	30.00
Ammonia, oil, waste, etc.....	10.00	10.00	10.00	18.00	18.00	18.00
Net operating expense per day.....	\$78.00	\$98.50	\$54.50	\$138.50	\$182.00	\$93.00
<i>Total cost of operation per year on basis of operating full capacity four months, ½ capacity four months and ¼ capacity four months equivalent to full operation for 216 days (60% load factor).</i>						
Operating cost of equivalent of 216 days of full operation.....	\$16,848	\$21,276	\$11,772	\$28,670	\$39,312	\$20,088
All labor expense for balance of year.....	4,248	4,104	4,248	6,264	6,336	6,192
5% depreciation on cost of mech. equip.....	3,100	2,600	3,500	5,950	4,950	6,750
3% depreciation on cost of building.....	1,125	1,050	1,050	1,950	1,800	1,800
5% on total investment for repairs, taxes, water and incidentals.....	4,975	4,350	5,250	9,200	7,950	9,750
Total annual expense.....	\$30,296	\$33,380	\$25,820	\$52,034	\$60,348	\$44,580
Number tons of ice produced annually	21,600	21,600	21,600	43,200	43,200	43,200
Total cost per ton of ice per annum....	\$1.40	\$1.55	\$1.19	\$1.21	\$1.40	\$1.03
Capacity in tons of ice per 24 hr. ....	300 tons.			400 tons.		
Type of plant (all 300 lb. cans).....	Distilled water.	Raw water.		Distilled water.	Raw water.	
Motive power.....	Compound condensing steam engines.	Electric motors.	Oil engines.	Compound condensing steam engines.	Electric motors.	Oil engines.
<b>Investment:</b>						
Mechanical equipment complete.....	\$171,000	\$141,000	\$195,000	\$218,000	\$178,000	\$250,000
Building.....	95,000	88,000	88,000	120,000	111,000	111,000
Total investment (excluding land)....	\$266,000	\$229,000	\$283,000	\$338,000	\$289,000	\$361,000
Daily operating expense:						
Chief engineer.....	\$7.50	\$6.50	\$7.50	\$8.00	\$7.00	\$8.00
Assistant engineers, 1.....	(2) 7.00	7.00	7.00	(2) 8.00	8.00	8.00
Oilers, 2.....	(4) 8.00	8.00	8.00	(4) 8.00	8.00	8.00
Firemen, 2.....	(2) 5.00			(2) 6.00		
Tankmen, 4.....	(10) 20.00	(15) 30.00	(15) 30.00	(14) 28.00	(21) 42.00	42.00
Storehouse men, 2.....	(2) 4.00	4.00	4.00	(4) 8.00	8.00	8.00
Other labor.....	(3) 6.00	(1) 2.00	2.00	(3) 6.00	(1) 2.00	2.00
Fuel, coal at \$3.50 per ton, oil at 3½¢ per gal. current at 1¢ per kw.-hr.....	\$115.50	\$180.00	\$45.00	\$154.00	\$240.00	\$60.00
Ammonia, oil, waste, etc.....	25.00	25.00	25.00	31.00	31.00	31.00
Net operating expense per day.....	\$198.00	\$262.50	\$128.50	\$257.00	\$346.00	\$167.00
<i>Total cost of operation per year on basis of operating full capacity four months, ½ capacity four months and ¼ capacity four months equivalent to full operation for 216 days (60% load factor).</i>						
Operating cost of equivalent of 216 days of full operation.....	\$42,768	\$56,700	\$27,756	\$55,512	\$74,736	\$36,072
All labor expense for balance of year.....	8,280	8,280	8,424	10,368	10,800	10,944
5% depreciation on cost of mech. equip.....	8,550	7,050	9,750	10,900	8,900	12,500
3% depreciation on cost of building.....	2,850	2,640	2,640	3,600	3,330	3,330
5% on total investment for repairs, taxes, water and incidentals.....	13,300	11,450	14,150	16,900	14,450	18,050
Total annual expense.....	\$75,740	\$86,120	\$62,720	\$97,280	\$112,216	\$80,996
Number tons of ice produced annually	64,800	64,800	64,800	86,400	86,400	86,400
Total cost per ton of ice per annum....	\$1.17	\$1.33	\$0.97	\$1.13	\$1.30	\$0.94

TABLE 105 (Continued). — INVESTMENT, DAILY AND YEARLY COST OF OPERATION OF LARGE ICE PLANTS.

Capacity in tons of ice per 24 hr .....	500 tons.			
	Type of plant (all 300 lb. cans).....	Distilled water.	Raw water.	
Motive power .....		Compound condensing steam engines.	Electric motors.	Oil engines.
Investment:				
Mechanical equipment complete.....	\$260,000	\$210,000	\$300,000	
Building.....	150,000	140,000	140,000	
Total investment (excluding land).....	\$410,000	\$350,000	\$440,000	
Daily operating expense:				
Chief engineer.....	\$9.00	\$8.00	\$9.00	
Assistant engineers, 1.....	(2) 10.00	10.00	10.00	
Oilers, 2.....	(4) 8.00	8.00	8.00	
Firemen, 2.....	(2) 7.00			
Tankmen, 4.....	(16) 32.00	(24) 48.00	48.00	
Storehouse men, 2.....	(4) 8.00	8.00	8.00	
Other labor.....	(4) 8.00	(2) 4.00	4.00	
Fuel, coal at \$3.50 per ton, oil at 3½¢ per gal., current at 1¢ per kw.-hr.....	\$192.50	\$300.00	\$75.00	
Ammonia, oil, waste, etc.....	36.00	36.00	36.00	
Net operating expense per day.....	\$310.50	\$422.00	\$198.00	
<i>Total cost of operation per year on basis of operating full capacity four months, ½ capacity four months and ¼ capacity four months equivalent to full operation for 216 days (60% load factor).</i>				
Operating cost of equivalent of 216 days of full operation.....	\$67,068	\$91,152	\$42,768	
All labor expense for balance of year.....	11,808	12,384	12,528	
5% depreciation on cost of mech. equip.....	13,000	10,500	15,000	
3% depreciation on cost of building.....	4,500	4,200	4,200	
5% on total investment for repairs, taxes, water and incidentals.....	20,500	17,500	22,000	
Total annual expense.....	\$116,876	\$135,736	\$96,496	
Number tons of ice produced annually.....	108,000	108,000	108,000	
Total cost per ton of ice per annum.....	\$1.08	\$1.26	\$0.90	

**Cold Storage.** — For hotel, dining car, and restaurant service it is necessary to have good storage and ample facilities for keeping eatables in first-class condition, as the supplies are usually bought in large quantities; this necessitates either an ice or mechanical refrigeration plant. For dining car service the building is generally located at one end of the sleeping and dining car stores, and in the basement of hotels or restaurants.

Comparing natural ice and mechanical refrigeration, the latter is by far the best means of keeping dining supplies; with natural ice the cooling process is limited, there is also dampness and poor ventilation to contend with; ice leaves a residue liable to foul unless the storage box is cleaned out frequently.

With the mechanical cold air process the proper temperature for keeping supplies in the best condition can be attained, and

the temperature can be varied for any class of goods; the air is purified and fresh at all times.

**Cold Air Refrigeration.** (Fig. 201.) — The walls and partitions are insulated similar to ice houses, and divided into compartments for storing the various classes of goods.

The mechanical plant is placed at one end of the building, and consists of a steam engine coupled to a double-acting ammonia compressor, an ammonia condenser and receiver, with all necessary ammonia gauges and gauge boards; connection pipes and fittings, including an air cooler, consisting of an iron tank with refrigerator coils, brine pump, air fan, and sundry connections.

The cooler is placed next to the cold storage room, and the wall between it and the engine room must be insulated similar to outer walls.

The following is a comparative estimate of installing and operating a cold air plant and natural ice refrigeration plant.

*Cold Air Plant.* — Six tons capacity, approximate cost of installation and operation.

Cold storage house 40' × 48' × 24' high, \$3600 at 6%..	\$216.00
Cost of 6-ton ice plant, \$3200 at 6% per annum.....	192.00
Foundations for ice plant, \$200 at 6% per annum.....	12.00
10 horsepower per annum at \$40 per horsepower.....	400.00
Maintenance, repairs, and depreciation.....	42.00
Labor, one man at \$2 per day (see note).....	730.00
Ammonia per annum.....	30.00
Water rates.....	35.00
	<u>\$1657.00</u>

NOTE. — One man can run an ordinary 35 horsepower plant and also assist in the shop or stores at other work. Less than 30% of his time is taken up with the cold storage plant.

*Natural Ice Plant.* — Approximate cost of installation and operation.

Increased height of building for ice storage with air ducts, drainage, lifts, and insulation, \$4800 at 6% per annum.	\$288.00
3 tons of ice per day at \$2 per ton.....	2190.00
Labor, one man at \$1.50 per day.....	548.00
	<u>\$3026.00</u>

From the above it will be noted that the cold air plant, besides keeping the supplies in better condition, is a good deal less costly than buying ice at the price quoted.

*Construction.* — For cold storage buildings the construction is about as follows:



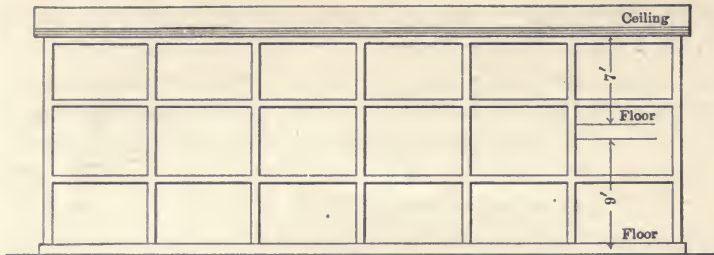

ELEVATION

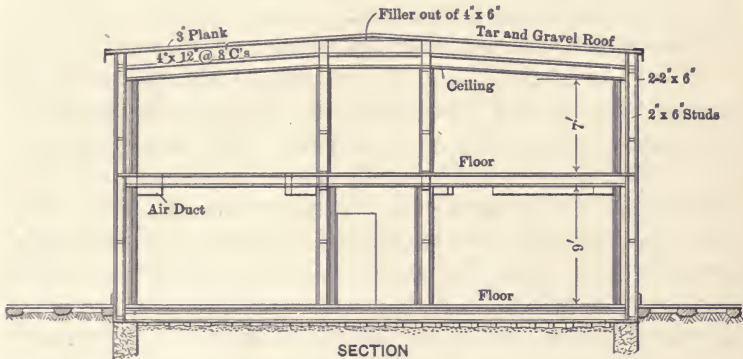

SECTION

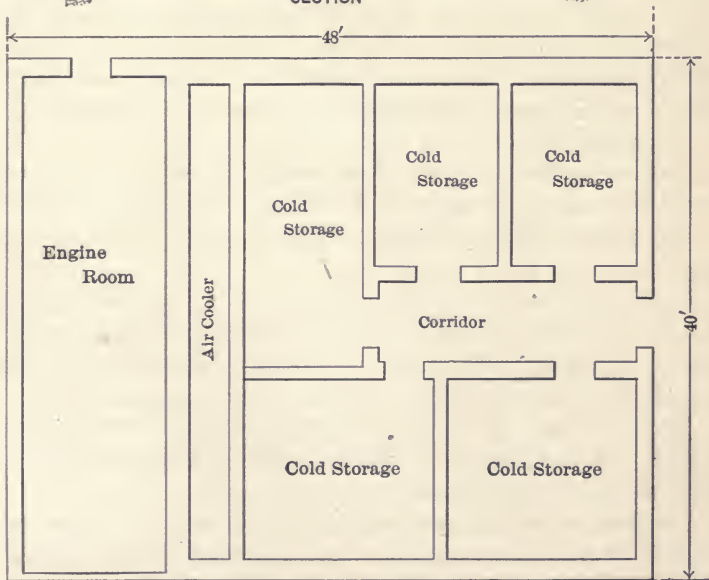

PLAN

Fig. 201. Cold Storage House.

Rubble or concrete foundation walls taken below frost, 24 in. thick, with 12-in. footing course.

*Outer Walls, Frame Buildings.* — Beginning on the outer face, two layers of 1-in. matched sheathing, with insulating paper between, 2'' × 6'' studs at 16-in. centers, two layers 1-in. sheathing, with insulating paper between, 2'' × 4'' studs 16-in. centers, with 1-in. matched sheathing, 2'' × 2'' studs 16-in. centers, with two layers of 1-in. sheathing and insulating paper between; with this arrangement the walls are about 20 in. thick. All spaces are filled with mill shavings.

*Ground Floor.* — A bed of gravel at least 12 in. thick, with 3'' × 3'' sills on top, at 18-in. centers, covered with 1-in. matched sheathing, and 1'' × 2'' scantling on top, and two layers of 2'' × 4'' matched flooring over, laid flat with insulating paper between. All spaces are filled with mill shavings.

*Inner Walls.* — Between cold storage rooms: 2'' × 6'' studs at 18-in. centers, with two layers of 1-in. matched sheathing on either side, and insulating paper between boards, all spaces filled with mill shavings.

Between cold storage rooms and corridors: 2'' × 8'' studs at 18-in. centers, with two layers of 1-in. matched sheathing and insulating paper between on the inside, and 1-in. matched sheathing, and 1'' × 2'' scantling 18-in. centers covered with two layers of matched sheathing, with insulating between, on the corridor side.

*Ceiling.* — Two-inch by 8-in. studs at 18-in. centers, with two layers of 1-in. matched sheathing on each side, with insulating paper between boards. Spaces filled with mill shavings.

*Roof.* — Two-inch by 8-in. studs, 18-in. centers, with two layers 1-in. sheathing on each side, with insulating paper between, roof joists 4'' × 12'' at 8-ft. centers, with 3-in. T. & G. boarding on top, covered with 5-ply tar and gravel roofing.

*Cold Air Ducts.* — Wooden air ducts are provided for exhausting the air from the various rooms to the fan and cooler, and from the cooler back into the rooms.

Insulation for the main suction ducts consists of two layers  $\frac{7}{8}$ -in. T. & G. sheathing, with double insulating papers between, and 1'' × 1'' battens on the outside covered with 1-in. T. & G.

sheathing; other ducts consist of double boarding with insulating paper between.

The ducts are placed usually on each side of the room close to the ceiling, with hardwood slides on the bottom of the delivery ducts and on the sides of the suction ducts.

### Stock Yards.

Stock yards are erected at way stations and terminals for receiving cattle for shipment, and also for rest and feeding purposes for cattle en route. The yards are located parallel with the siding tracks convenient to the roadway at stock business points. (Figs. 202 and 203.)

The ordinary wayside station stock yard consists of a series of fenced-in pens, with feeding and water troughs, including feed barns and shelters when necessary.

The terminal stock yards are usually housed in and are arranged with pens, feeding and water facilities, to suit the different classes of stock.

The usual arrangement is to provide loading and unloading platforms with chutes alongside the track. The platforms are made narrow so that the gates of the chutes when open shall come close to the cars for convenience in loading the cattle. The chutes lead to a main alleyway, from which the distribution of pens is arranged, the pens being divided to hold a car or portion of a car load, and made so as to open into one another and to branch alleyways in the center, so that the cattle may be sorted and classified if desired. Barns and shelters are erected on the branch alleyways for feeding purposes when necessary.

In addition to feeding and shelter sheds, water has also to be provided, with frost-proof hydrant valves to avoid freezing, the pipes being graded to drain when not in use.

*Construction.*—The construction generally is cedar posts 6 in. to 9 in. in diameter, placed 5 to 6 ft. centers, set into the ground solid. The fencing is from 6 to 7 ft. high, of 1- to 2-in. material, with 3- to 8-in. spaces between. Feed racks are placed on one or two sides, made with 2" × 6" plank, the height and width varying to suit the stock. Water troughs are placed on the opposite side of feed racks, and are made of 2-in. plank supported on 2-in. plank brackets, with three-quarters to 1-in.

water supply taken from a 1½-in. main and extending above the water trough with a goose neck. The floor, where the business amounts to anything, is usually of concrete finished rough.

An ordinary 20-car capacity stock yard would consist of a 4-ft. platform placed 7 ft. from rail, with 4 loading chutes 40-ft. centers and 3 unloading chutes ramped down to main alleyway, the depth varying from 20 to 50 feet or more, and the depth of alleyway 12 to 13 ft. by 200 ft. long.

The area covered by the pens behind the main alleyway would be 213 ft. long and 160 ft. deep, divided into 10 pens, and one branch alleyway in the center 13 ft. wide. The pens front and back would be 50' × 50', and the center ones 50' × 100'. In the branch alleyways two shelters and two hay barns are erected projecting into the center pens as per Fig. 202.

*Approximate cost.* — The approximate cost of open stock yards with concrete floor averages from 20 to 35 cents per square foot of area covered.

The approximate cost of a 20-car capacity stock yard with feed racks, water troughs, hay barns, shelter, concrete floor, etc., complete, \$5500 to \$7500.

The cost of frame barns and shelters, from 50 to 75 cents per square foot.

The cost of enclosed stock yards, concrete floor for single-story frame buildings with skylights, etc., complete, varies from 65 to 90 cents per square foot when the amount is fairly large.

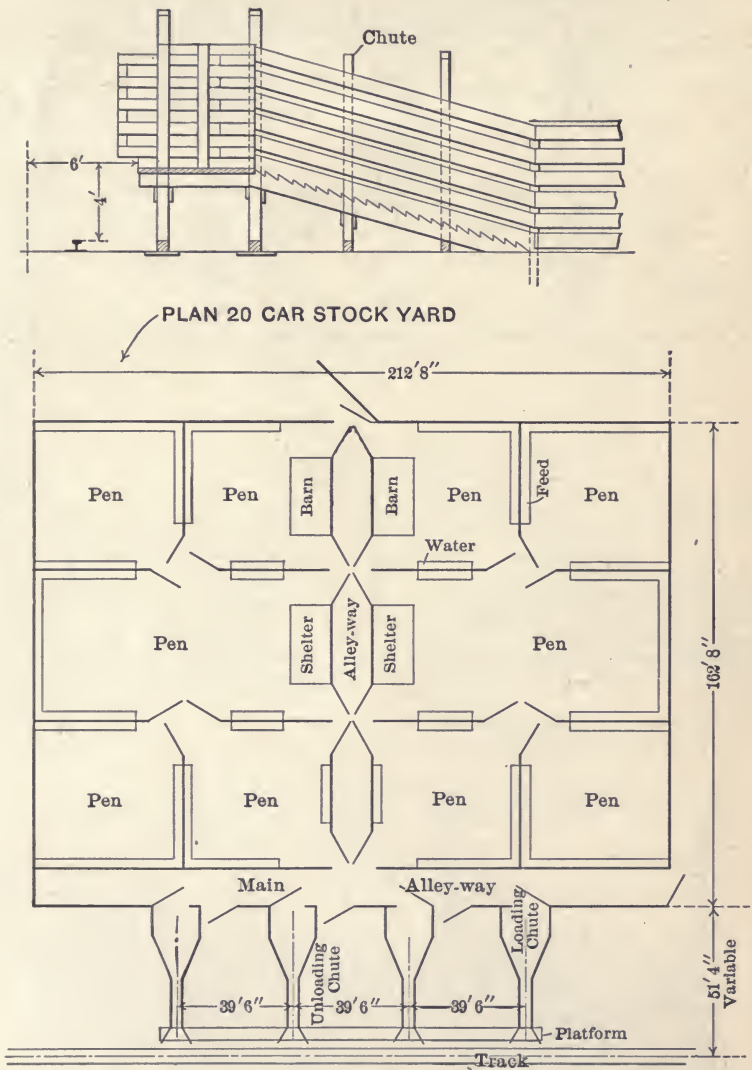
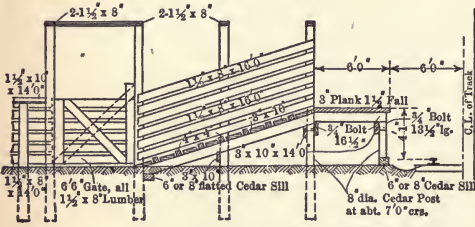
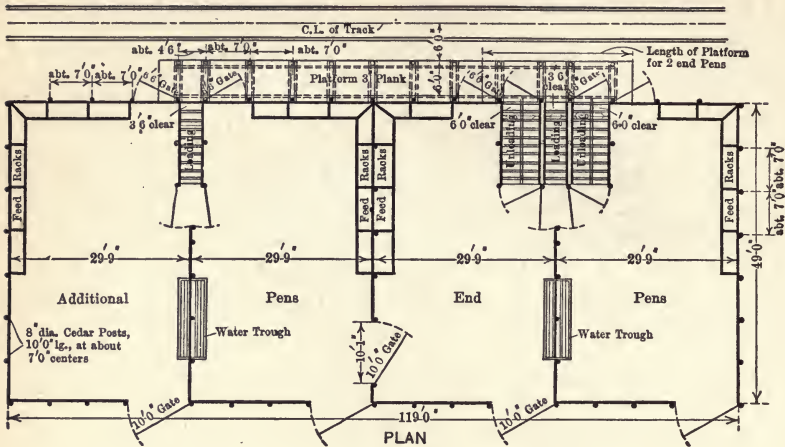
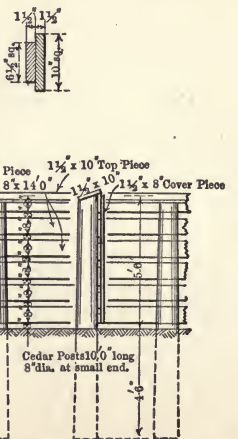
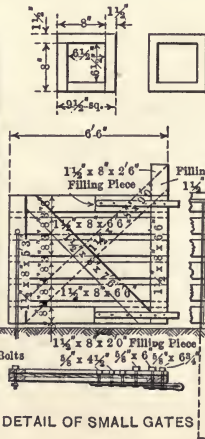
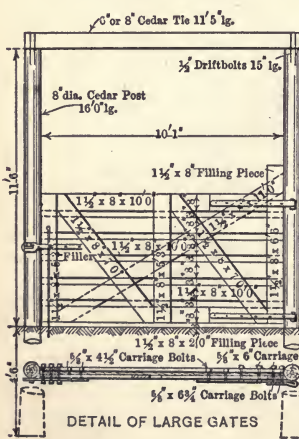
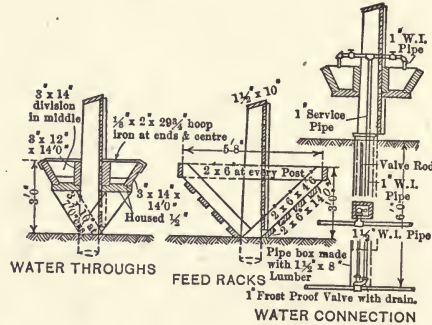

Fig. 202.



SECTION THRO' LOADING CHUTES





At the top of the post about three-foot centers two horizontal arms project 3 ft. towards the track arranged to hold the mail bag. The arms have a steel spring attachment at the post end so that when the bag is released they automatically rise and fall towards the post, one going up and the other down. (Fig. 204.)

A light iron ladder is placed for convenience of the operator, so that he may be able to catch the arms and tie the mail bag in position.

*Approximate cost of an iron mail crane complete, \$35.*

The relation of the mail crane to the mail car is shown, Fig. 205, and the design of the catcher across the door of the car, Fig. 206; the catcher is operated by the mail clerk pulling the upper handle which brings it into a horizontal position ready to engage and catch the bag suspended on the mail crane. On releasing the handle the catcher drops down into a vertical position as shown on the elevation.

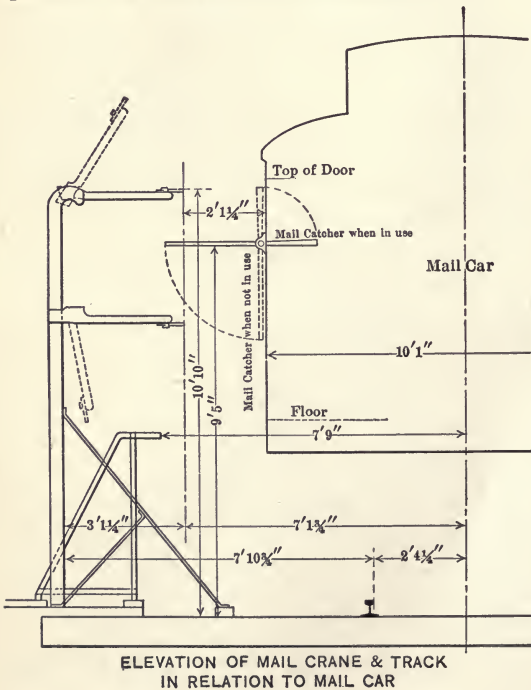

ELEVATION OF MAIL CRANE & TRACK  
IN RELATION TO MAIL CAR

Fig. 205.

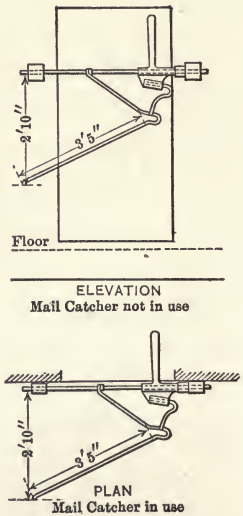

Fig. 206.



**Track Tanks.** — Track tanks are used to a limited extent, and usually consist of steel troughs placed directly on the ties, to hold the water so that locomotives can scoop up a supply while in motion, and are used for passenger and freight service to expedite train movement on congested districts.

A comprehensive article on this type of structure is given in detail in the *Railroad Gazette*, March 13, 1908, by H. H. Ross.

The tanks must be located where the supply of water is abundant and of good quality; 15 to 50 per cent of the water is wasted by being forced out over the sides and ends by the engine scoops. The speed for satisfactory service is from 25 to 30 miles per hour, and the tracks are graded at the approaches to enable the necessary speed to be made, and for this reason track tanks should be away from any structures, crossings, yards, etc., and be well drained so that the water that gets into the bank is carried away quickly. This is done by stone-filled trenches and tile between tracks, the ballast being covered with large flat stones to hold the ballast and shed the water.

*Approximate cost.* — A double-track installation will cost \$15,000 to \$30,000 exclusive of grading, track work, and drainage. The maintenance averages probably about 8 per cent of the cost.

*Construction.* — The ties supporting the trough should be of white oak 8" × 10" × 8' 6" long, and track thoroughly surfaced and filled in with stone ballast and same quality of ballast continued for at least 1000 feet beyond the troughs on the trailing ends, and all ties tie plated.

Water is usually supplied from elevated tanks, with a large-sized main reduced for the different inlets; 1½ to 2 minutes are required to refill trough after an engine has scooped, and the filling is done with automatic valves.

Trough recommended, 28 in. wide, 7½ in. deep, and 2000 ft. long, to give 5000 to 6000 gal. in a run. When track tanks are used in cold climates, it is necessary to heat the water to keep it from freezing, which is done by steam blowing, or by circulating by means of a pump or an injector.

## CHAPTER XVIII.

## WATER STATIONS.

**General.** — The ordinary railroad water station usually consists of an elevated tank for storage purposes, a pumping outfit or gravity main to supply the tank, and standpipes when necessary for convenient service. A locomotive consumes from 30 to 100 gal. per mile, and carries from 2000 to 7000 gal. Owing to mixed traffic, possible detentions and climatic conditions, however, it has been found necessary to place water stations 10 to 20 miles apart, usually at regular stopping points along the right of way.

*Purity.* — As the water is to be used principally for locomotive purposes, a sample should be sent to the company's chemist to be analyzed to ascertain if it is suitable for the purpose. Conditions will sometimes make it necessary to treat the water chemically to render it soft for economical boiler service.

The treatment may be lime only, when the hardness is due to carbonates of lime and magnesia, or soda ash when the hardness is due to sulphates of lime and magnesia. The method of applying these reagents to the water may require a special mechanical outfit, or a mixer with valve, feed, etc., connected with the water supply, can be so arranged that every stroke of the water piston may take in a desired portion of the chemical previously made ready. To render the work efficient, it should be closely watched and supervised by the company's chemist or his assistant.

*Supply.* — When a municipal water service is established and the rates are favorable, there may be a saving in obtaining water by meter or other agreement. Under ordinary circumstances, however, the permanent supply is usually obtained from artesian or driven wells, or from a natural lake, river, or stream, and the delivery may be by gravity or by pumping, local conditions determining the method employed. A gravity supply usually requires a dam and spill-way for storage purposes. When the location is convenient and a permanent and abundant supply

can be obtained in a natural or artificial basin, a gravity supply is the most economical.

EQUIVALENTS OF WATER BY WEIGHT AND MEASURE.

Water.	U. S. gal- lons.	Imperial gallons.	Cubic feet.	Cubic inches.	Pounds.
U. S. gallon.....	1.00	0.833	0.133	231	8.33
Imperial gallon.....	1.2	1.00	0.16	277.274	10.00
Cubic foot.....	7.48	6.23	1.00	1728	62.35
Cubic inch.....	0.0043	0.0036	0.00058	1.00	0.036
One pound.....	0.12	0.10	0.16	27.72	1.00

A miner's inch of water is approximately equal to a supply of 12 U. S. gallons per minute.

TABLE 106. — CONVERTING DISCHARGE IN SECOND-FEET PER SQUARE MILE INTO RUN-OFF IN DEPTH IN INCHES OVER THE AREA.

Discharge in second-feet per square mile.	Run-off in inches.				
	1 day.	28 days.	29 days.	30 days.	31 days.
1.....	0.03719	1.041	1.079	1.116	1.153
2.....	0.07438	2.083	2.157	2.231	2.306
3.....	0.11157	3.124	3.236	3.347	3.459
4.....	0.14876	4.165	4.314	4.463	4.612
5.....	0.18595	5.207	5.393	5.578	5.764
6.....	0.22314	6.248	6.471	6.694	6.917
7.....	0.26033	7.289	7.550	7.810	8.070
8.....	0.29752	8.331	8.628	8.926	9.223
9.....	0.33471	9.372	9.707	10.041	10.376

NOTE. — For partial month, multiply the values for one day by number of days.

1 sec.-ft. equals 7.48 United States gallons per second; equals 448.8 gals. per minute; equals 646,317 gals. for one day.

1 sec.-ft. for one year covers one square mile 1.131 ft. or 13.572 in. deep.

1 sec.-ft. for one year equals 31,536,000 cu. ft.

1 sec.-ft. for one day equals 86,400 cu. ft.

1,000,000,000 cu. ft. equals 11,570 sec.-ft. for one day.

1,000,000,000 cu. ft. equals 414 sec.-ft. for one 28-day month.

1,000,000,000 cu. ft. equals 399 sec.-ft. for one 29-day month.

1,000,000,000 cu. ft. equals 386 sec.-ft. for one 30-day month.

1,000,000,000 cu. ft. equals 373 sec.-ft. for one 31-day month.

1,000,000,000 United States gals. per day equals 1.55 sec.-ft.

100 United States gals. per minute equals 0.223 sec.-ft.

1 in. deep on 1 square mile equals 2,323,200 cu. ft.

1 in. deep on 1 square mile equals 0.0737 sec.-ft. per year.

1 HP. equals 550 ft.-lb. per second.

1 HP. equals 1 sec.-ft. falling 8.80 ft.

1½ HP. equals 1 Kw.

To calculate water power quickly:  $\frac{\text{sec. ft.} \times \text{fall in ft.}}{11} = \text{net horsepower on water wheels realizing 80 per cent of theoretical power.}$

*Area of Pipe.* — To find the area of a required pipe, the volume and velocity being given, multiply the number of cubic feet of water by 144 and divide the product by the velocity in feet per minute.

*Velocity.* — To find the velocity in feet per minute to discharge a stated number of gallons per minute divide the amount of discharge in gallons per minute by the number of gallons in one lineal foot, or the number of gallons per minute by 144, and divide by the area of pipe in inches.

TABLE 107. — NUMBER OF U. S. GALLONS IN ONE LINEAL FOOT OF PIPE.

Inside diameter of pipe.	1 in.	2 in.	2½ in.	3 in.	4 in.
Cubic foot.....	0.0055	0.0218	0.0341	0.0491	0.0873
Gallons per lineal foot..	0.0408	0.1632	0.2550	0.3673	0.6528
Area, square inches.....	0.785	3.14	4.9	7.06	12.56
	6 in.	8 in.	9 in.	10 in.	12 in.
Cubic foot.....	0.1963	0.3490	0.4418	0.5455	0.7854
Gallons per lineal foot..	1.469	2.611	3.305	4.081	5.875
Area, square inches.....	28.27	50.26	63.61	78.54	113.09

*Depth of Suction.* — The mean pressure of the atmosphere is estimated at 14.7 lb. per square inch. With a perfect vacuum at sea level it will therefore sustain a column of mercury 29.9 in., or a column of water 33.9 ft. high. This is the theoretical height that a perfect pump would draw water. Owing to air in the water, valve leakage, etc., the actual height in practice seldom exceeds 20 ft., and the velocity through the suction pipe should not exceed 200 ft. per minute, as the resistance of suction will be too great. To obviate this tendency the suction pipe is usually one or two sizes larger than the delivery or discharge pipe.

*Service Pipe.* — Steel, cast-iron, plain wrought-iron, wood and galvanized iron pipe are used extensively; cast iron is the most

durable and reliable for underground service, and above ground plain wrought-iron pipe. In many situations wood pipe may be quite satisfactory.

The depth to which pipe should be placed in the ground should be sufficient to avoid injury from frost, usually 4 to 5 ft. A water main laid in a rock-cut trench is less liable to freeze up if covered with broken stones.

TABLE 108. — APPROXIMATE COMPARATIVE COST PER FOOT OF DIFFERENT PIPES.

Size of pipe.	6 in.	8 in.	10 in.	12 in.
Wood pipe, wire wound, uncoated.....	\$0.32	\$0.40	\$0.50	\$0.65
Wood pipe, wire wound, asphalted.....	0.34	0.42	0.52	0.67
Wood pipe, wire wound, burlapped.....	0.40	0.50	0.60	0.75
Iron pipe, cast.....	0.63	0.93	1.28	1.66
Steel pipe, lap welded, burlapped.....	0.76	1.05	1.60	2.10
Iron wrought.....	0.93	1.41	2.00	2.45

*Service Connections.* — The discharge pipe should enter the water tank at the bottom, as it reduces the head and takes less power than feeding it from the top.

Provide a check valve in delivery pipe and a waste cock in the discharge chamber so that air may be expelled, a stop valve for shutting off the back pressure so that the pump can be opened for inspection.

Set up the pump on solid foundation of concrete; wood is liable to rot and cause leaky joints. To obviate jar or vibration, use expansion bolts to anchor the pump.

Arrange the steam pipe feed so that the water of condensation will drip away from the pump when not in use, and insert drip cock.

An air chamber on the suction pipe will make the pump work smoother at moderate speed, and is advisable, as it prevents pounding or water hammer; in high lifts it is a necessity.

Unless the suction lift and length of supply pipe are moderate, a foot valve and strainer are also advised for all pumps raising water by suction.

The foot valve is placed at the bottom of the suction pipe and holds the priming.

The suction pipe must be entirely free from all leakage.

Lay suction pipes with a uniform grade from the pump to the source of supply, and avoid air pockets. All pipes should be as direct as possible; use full round bends for elbows and Y's for tees.

*Wrought-iron and Steel Pipes.* — All wrought-iron and steel pipes must be equal in quality to "standard."

The pipes shall not be less than the following average thickness and weight per lineal foot; supplied in random lengths with threads and couplings.

TABLE 109. — APPROXIMATE COST AND WEIGHT OF WROUGHT-IRON PIPES.

Inside size of pipe.	Thick-ness.	Normal weight per lineal foot.	Approx. cost per 100 feet.	Approx. cost per lineal foot.	Inside size of pipe.	Thick-ness.	Normal weight per lineal foot.	Approx. cost per 100 feet.	Approx. cost per lineal foot.
In.	In.	Lb.			In.	In.	Lb.		
1	0.13	1.67	\$6.00	\$0.06	5	0.25	14.50	\$72.00	\$0.72
1½	0.14	2.68	9.00	0.09	6	0.28	18.76	93.00	0.93
2	0.15	3.61	13.00	0.13	7	0.30	23.27	116.00	1.16
2½	0.20	5.74	23.00	0.23	8	0.32	28.18	141.00	1.41
3	0.21	7.54	30.00	0.30	9	0.34	33.70	168.70	1.68
3½	0.22	9.00	45.00	0.45	10	0.36	40.00	200.00	2.00
4	0.23	10.66	54.00	0.54	11	0.37	45.00	225.00	2.25
4½	0.24	12.49	63.00	0.63	12	0.37	49.00	245.00	2.45

*Cast-iron Pipes.* — All cast-iron pipe and fittings must be uncoated, sound, cylindrical and smooth, free from cracks, sand holes, and other defects, and of a uniform thickness and of a grade known in commerce as "extra heavy," cast in lengths to lay twelve feet, with bell and spigot joints, and to withstand a static pressure of not less than 130 lb. per square inch.

*Joints.* — All joints must be made with picked oakum and molten lead and made water-tight. For estimating, take 1½ lb. of soft pig lead for each joint for each inch in the diameter of the pipe, and 1 oz. of oakum for each joint for each inch in the diameter of the pipe.

The average total cost per foot for installing cast-iron water mains, depth of trench 5 feet, from 4 inches to 24 inches in diameter, is given in Table 110, page 431.

**Approximate Cost of Installing Cast-iron Water Mains (4-in. to 24-in. Pipes).**

*Pipes (cast) in 12 ft. lengths F. O. B. cars . . . . .* \$25 to \$35 per ton  
 (See table for weights.)

*Loading and hauling:*

Loading from cars to wagons . . . . . 5 to 30¢ per ton  
 Unloading from wagons at site . . . . . 2½ to 15¢ per ton  
 Lost time by teams (loading and unloading) . . . . . 2½ to 15¢ per ton  
 Total . . . . . 10 to 60¢ per ton

*Hauling (2-ton loads) per mile . . . . .* 9 to 21¢ per ton mile

*Trenching:*

Excavation 5 ft. deep and 21 in. wider than diameter of pipe, bell holes dug out just before laying pipe.

Excavation, ordinary earth per cu. yd. . . . . \$0.20 to \$0.50  
 “ medium gravel per cu. yd. . . . . 0.30 to 0.60  
 “ cemented gravel per cu. yd. . . . . 0.75 to 1.00  
 “ boulders and hard pan per cu. yd. . . . . 1.25 to 1.50  
 “ loose rock and hard pan per cu. yd. . . . . 1.75 to 2.00  
 “ solid rock and hard pan per cu. yd. . . . . 2.25 to 3.50

*Laying (including caulking) per lin. ft. . . . .* 0.05 to 0.30

*Back filling (including puddling) per cu. yd. . . . .* 0.05 to 0.20

*Miscellaneous.* 10 per cent to take care of overhead charges, supervision and contingencies, etc.

TABLE 110. — AVERAGE TOTAL COST PER FOOT INSTALLING CAST-IRON WATER MAINS.

Size of pipes.	Weight per ft., lbs.	Cost of pipe at \$35 per ton deliv'd.	Loading and hauling.	Excav. and backfill.	Laying and jointing.	Miscellaneous.	Total cost per lin. ft.
4	22	\$0.39	\$0.01	\$0.18	\$0.05	\$0.07	\$0.70
6	36	0.63	0.02	0.21	0.08	0.11	1.05
8	53	0.93	0.03	0.24	0.10	0.15	1.45
10	73	1.28	0.04	0.27	0.13	0.18	1.90
12	95	1.66	0.05	0.30	0.15	0.19	2.35
14	119	2.09	0.06	0.33	0.18	0.24	2.90
16	147	2.57	0.08	0.36	0.20	0.29	3.50
18	176	3.08	0.09	0.39	0.23	0.36	4.15
20	208	3.64	0.12	0.42	0.25	0.47	4.90
24	282	4.93	0.14	0.45	0.30	0.58	6.40

The above prices are for pipe laid in a 5-foot trench. For approximate weight, thickness and dimension of cast-iron pipe, see Tables 111, 112, 113 and 114, pages 432, 433, 434 and 435.

# 432 WEIGHT AND DIMENSIONS OF CAST IRON PIPE.

TABLE 111. — APPROXIMATE WEIGHT, THICKNESS AND DIMENSIONS OF CAST-IRON PIPE FOR WATER.

300 foot head, 130 pounds pressure.



## Hub and Spigot Pipe for Lead Joints.

	In. 3	In. 4	In. 6	In. 8	In. 10	In. 12	In. 14	In. 16	In. 18	In. 20	In. 24	In. 30	In. 36
Diameter.....	3	4	6	8	10	12	14	16	18	20	24	30	36
Thickness.....	$4\frac{7}{8}$	$5\frac{1}{2}$	$7\frac{1}{2}$	$10\frac{3}{4}$	$12\frac{1}{2}$	$14\frac{1}{2}$	$16\frac{1}{2}$	$18\frac{3}{4}$	$20\frac{1}{2}$	$22\frac{1}{2}$	$26\frac{3}{4}$	$33\frac{1}{2}$	$41\frac{1}{2}$
Inside dia. of hub	$4\frac{1}{2}$	$5\frac{1}{2}$	$7\frac{1}{2}$	$10\frac{1}{2}$	$12\frac{1}{2}$	$14\frac{1}{2}$	$16\frac{1}{2}$	$18\frac{1}{2}$	$20\frac{1}{2}$	$22\frac{1}{2}$	$26\frac{1}{2}$	$33\frac{1}{2}$	$39\frac{1}{2}$
Depth of hub inside	3	$3\frac{1}{2}$	$3\frac{1}{2}$	$3\frac{1}{2}$	4	4	$4\frac{1}{2}$	$4\frac{1}{2}$	$4\frac{1}{2}$	$4\frac{1}{2}$	5	5	$5\frac{1}{2}$
Length from end of spigot to inside of hub.....	Ft. 12	Ft. 12	Ft. 12	Ft. 12	Ft. 12	Ft. 12	Ft. 12	Ft. 12	Ft. 12	Ft. 12	Ft. 12	Ft. 12	Ft. 12
Wt. per running ft.	Lb. 16	Lb. 20	Lb. 30	Lb. 45	Lb. 65	Lb. 85	Lb. 110	Lb. 135	Lb. 175	Lb. 200	Lb. 265	Lb. 375	Lb. 480
Weight per length.	192	240	360	540	780	1020	1320	1620	2100	2400	3180	4500	5760

APPROXIMATE WEIGHT OF PLUGS.		APPROXIMATE WEIGHT OF SLEEVES.		APPROXIMATE WEIGHT OF CAPS.	
In.	Lb.	In.	Lb.	In.	Lb.
3	6	3	35	3	11
4	7	4	45	4	14
6	12	6	57	6	27
8	29	8	72	8	38
10	60	10	127	10	75
12	70	12	190	12	85



Reducer.

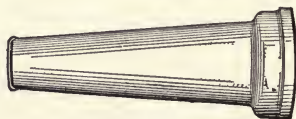

Increaser.

APPROXIMATE WEIGHT AND DIMENSIONS OF REDUCERS.				APPROXIMATE WEIGHT AND DIMENSIONS OF INCREASERS.			
Size.		Weight.	Length over all.	Size.		Weight.	Length over all.
In.	In.	Lb.	Ft. In.	In.	In.	Lb.	Ft. In.
3	to 2	23	2 6	2	to 3	25	2 6
4	" 3	78	2 9	3	" 4	84	2 9
6	" 3	81	2 10	3	" 6	90	2 10
6	" 4	96	2 8	4	" 6	105	2 8
8	" 4	155	2 7	4	" 8	164	2 7
8	" 6	165	3 2	6	" 8	175	3 2
10	" 4	185	3 0	8	" 10	246	3 2
10	" 6	190	3 0	6	" 10	220	3 0
10	" 8	195	3 1	4	" 10	200	3 0
12	" 4	230	3 10	4	" 12	250	3 10
12	" 6	260	3 10	6	" 12	275	3 10
12	" 8	275	3 6	8	" 12	300	3 6
12	" 10	280	3 6	10	" 12	315	3 6



TABLE 112. — APPROXIMATE WEIGHT AND DIMENSIONS OF STANDARD  $\frac{1}{4}$  OR 90° BENDS.

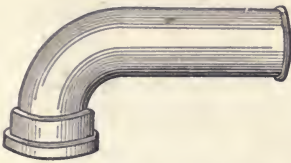

Standard  $\frac{1}{4}$  or 90° Bend.

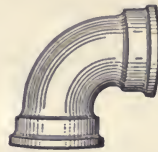

$\frac{1}{4}$  Bend, Double Hub.

Size.	Weight.	Length from outside of spigot to center of pipe.		Length from outside of hub to center of pipe.		Size.	Weight.	Length from outside of spigot to center of pipe.		Length from outside of hub to center of pipe.	
		Ft.	In.	Ft.	In.			Ft.	In.	Ft.	In.
3	38	1	7		$8\frac{1}{2}$	8	225	2	7	1	$2\frac{1}{2}$
4	61	1	6		$10\frac{1}{2}$	10	422	2	10	2	4
6	107	2	1		$11\frac{1}{2}$	12	480	3	0	2	8

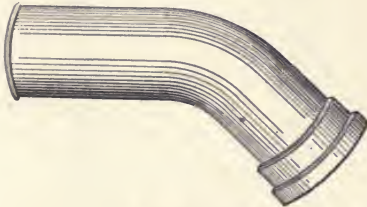

$\frac{1}{8}$  or 45° Bend.

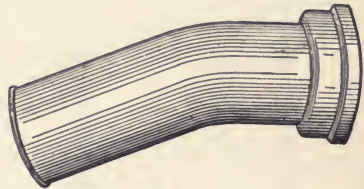

$\frac{1}{8}$  or 22 $\frac{1}{2}$ ° Bend.

WEIGHT OF STANDARD $\frac{1}{8}$ OR 45° BENDS.		WEIGHT OF STANDARD $\frac{1}{8}$ OR 22 $\frac{1}{2}$ ° BENDS.	
Size.	Weight.	Size.	Weight.
In.	Lb.	In.	Lb.
3	37	3	36
4	60	4	61
6	104	6	109
8	190	8	161
10	260	10	257
12	285	12	290

Weights are for bends with hub and spigot. If double hubs, weights will be about the same and the second column of dimensions will apply for length of quarter bends.

One thirty-second or 11 $\frac{1}{4}$ ° bends and  $\frac{1}{8}$ ° or 5 $\frac{5}{8}$ ° bends are special and patterns only are usually kept in stock.

TABLE 113. — APPROXIMATE WEIGHTS AND DIMENSIONS OF TEES.

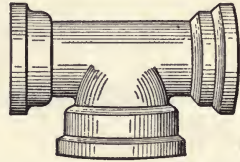
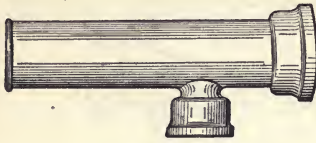

Tee with Two Hubs and One Spigot.

Tee with Three Hub Ends.

Size.		Weight.	Length over all.		Length of branch over all from center of pipe.
In.	In.	Lb.	Ft.	In.	In.
3	off 3	82	3	0	10 $\frac{1}{2}$
3	" 6	130	3	0	10 $\frac{1}{2}$
3	" 8	180	3	0	10
3	" 10	250	3	0	10 $\frac{3}{4}$
4	" 4	97	2	5 $\frac{1}{2}$	9 $\frac{3}{8}$
4	" 6	165	3	0	10 $\frac{1}{2}$
4	" 8	195	3	0	10
4	" 10	265	3	0	10 $\frac{3}{4}$
4	" 12	345	3	0	11 $\frac{3}{4}$
6	" 6	175	3	0	10
6	" 8	210	3	0	10
6	" 10	250	3	0	10 $\frac{3}{4}$
6	" 12	350	3	0	11 $\frac{3}{4}$
8	" 8	220	3	0	10
8	" 10	270	3	0	10 $\frac{3}{4}$
8	" 12	372	3	0	11 $\frac{3}{4}$
10	" 10	305	3	0	11 $\frac{1}{2}$
10	" 12	385	3	0	12 $\frac{1}{2}$
12	" 12	392	3	0	12 $\frac{1}{2}$
16	" 16	720	4	6	16
16	" 20	1240	4	6	16

APPROXIMATE WEIGHT AND DIMENSIONS OF "GLOBE" TEES.

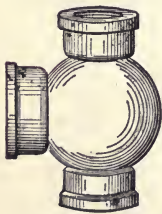

Globe Tee, Three Hub Ends.

Size.		Weight.	Length over all.		Length of branch over all from center of pipe.
In.	In.	Lb.	Ft.	In.	In.
4	off 4	128	1	8	10
4	" 6	138	1	8	10
4	" 8	330	1	8	10
4	" 10	352	2	4	12 $\frac{3}{4}$
4	" 12	440	2	4	14
6	" 6	149	1	8	10
6	" 8	198	1	8	10
6	" 10	365	2	4	12 $\frac{3}{4}$
6	" 12	460	2	4	14
8	" 8	195	1	8	9 $\frac{1}{2}$
8	" 10	362	2	4	14
8	" 12	476	2	4	14
10	" 10	394	2	4	14
10	" 12	485	2	4	14
12	" 12	490	2	4	14

TABLE 114. — APPROXIMATE WEIGHT AND DIMENSIONS OF CROSSES.

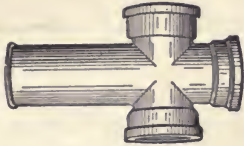
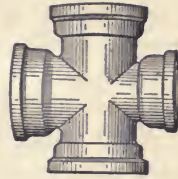
Cross with Three Hubs and  
One Spigot.

Cross with Four Hubs.

Size.		Weight.	Length over all.		Length over branches, inside of hubs.
In.	In.	Lb.	Ft.	In.	In.
3	off 3	102	2	8	8
3	“ 4	108	2	8	8
3	“ 6	190	3	0	12
4	“ 4	130	2	8	12
4	“ 6	208	3	0	14
4	“ 8	217	3	0	13
4	“ 10	274	3	0	14
4	“ 12	365	3	0	16
6	“ 6	215	3	0	13
6	“ 8	245	3	0	13
6	“ 10	300	3	0	14
6	“ 12	350	3	0	16
8	“ 8	285	3	0	13
8	“ 10	365	3	0	14
8	“ 12	370	3	0	16
10	“ 10	360	3	0	16
10	“ 12	380	3	0	18
12	“ 12	405	3	0	18

### Railroad Water Tanks.

**Water Tanks.** — The capacity of the ordinary standard tank is from 60,000 to 100,000 gal. There is a tendency, however, towards very much larger tanks, and on many roads the standard includes tanks 100,000 to 200,000 gal., particularly at engine terminals.

The tank should be large enough to supply the demand for water without continuous pumping, or where a large number of engines take water within a limited time, roadside tanks should also be large enough so that it is not necessary to employ night pumpers.

It is now quite common practice to erect the water tank remote from the tracks and to deliver through underground pipes to standpipes or water columns, and as it is desirable to deliver the water to the engines in the least possible time, the pipe and head of water should be large enough to give the required discharge in the time desired.

The usual height of tank for locomotive supply is 20 ft. from top of rail to bottom of tank and the discharge in United States gallons per minute from water tank to standpipe for various sizes of supply pipes, 1000 ft. in length, and two different types of standpipes are given in the following Table 115.

A tank with from 16 to 20 ft. of water and a 12-in. standpipe with 1000 ft. of 14-in. supply pipe will deliver from 3500 to 4000 gal. per minute.

The tanks are usually built of wood although steel tanks are being used to a large extent. According to the American Railway Bridge and Building Association, the average life of the various timbers entering into the construction of water tanks is about as follows, provided the most rigid specifications and inspection be adhered to:

Cypress.....	40 years
Redwood.....	30 years
Cedar.....	30 years
White pine.....	20 years
Douglas fir.....	16 years

The tank staves are usually 6 to 8 in. wide and uniform from end to end, and 3 in. thick with edges accurately planed on

radial lines from the center of the tub; the croze in each stave should be 3 in. in the clear from end of stave with  $\frac{5}{8}$ -in. gain, accurately cut to uniform dimensions on one circle for all staves. Three 1-in. dowel pins made of the same material as the staves should be furnished with each stave and the staves bored for dowels.

TABLE 115.

WATER DISCHARGE FROM TANK TO STANDPIPE

10° Telescopic Standpipe Supply Pipe			Discharge in U.S. Gallons per Minute From Water Tank to Standpipe For Various Supply pipes 1000 ft. lg.	10° Rigid Standpipe Supply Pipe		
8°	10°	12°		8°	10°	12°
900	1550	2500	35	972	1700	2600
855	1492	2422	13	943	1650	2515
821	1434	2306	12	914	1600	2430
786	1377	2210	11	886	1550	2346
751	1319	2114	10	857	1500	2261
717	1262	2018	9	828	1450	2177
682	1204	1922	8	800	1400	2092
658	1146	1826	7	772	1350	2008
623	1088	1730	6	743	1300	1923
588	1030	1634	5	714	1250	1838
554	973	1538	4	686	1200	1754
519	915	1442	3	657	1150	1669
485	858	1346	2	628	1100	1585
450	800	1250	1	600	1050	1500

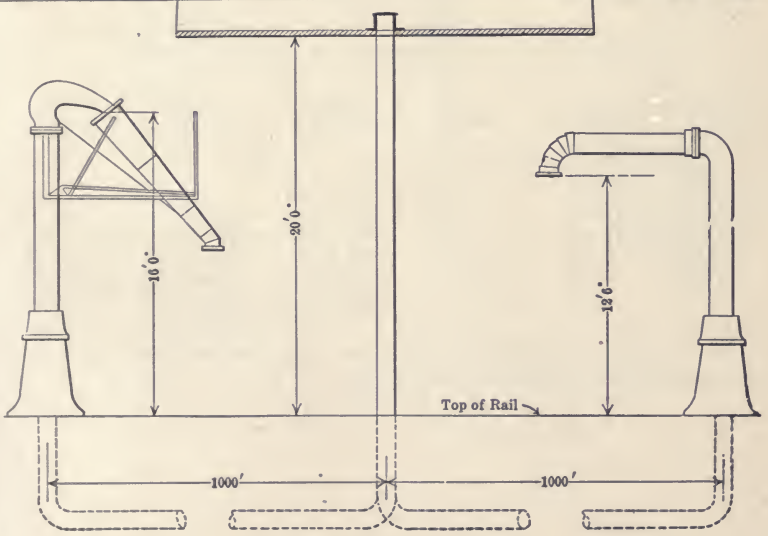

The floor or bottom of tank is usually 3 in. thick of 8- to 12-in. plank full length without splicing and every joint machine-made. The planks should be joined by 1-in. dowel pins about 30-in. centers.

The hoop bands around the tank are usually flat, although round hoops are coming into general use and oval or half round hoops are also used to some extent. The band iron lugs are usually fastened to the hoops by rivets or a single- or double-bolt cast lug connection is used. The hoop should be of wrought iron rather than steel.

The frame or tower for a wood tank is commonly a twelve-post structure of 12" × 12" timber braced according to height.

Usually the tank is roofed over and the supply and discharge pipes are enclosed and insulated. In cold climates the tower is housed in and a small stove is installed, the stove pipe extending up through the tank. In some cases the entire tank is housed in, as shown in Fig. 209.

A 50,000-gal. tank with steel substructure, recommended by the A. R. E. A., is shown in Fig. 207. The approximate average cost is about \$2500.

TABLE 116. — APPROXIMATE COST OF WATER TANKS COMPLETE; FOR TOWERS 20 FEET HIGH FROM RAIL TO TANK FLOOR.

Approximate capacity in U. S. gallons.	Height tank staves.	Diameter tank.	Semi-enclosed, wood. Fig. 208a.	Semi-enclosed, masonry. Fig. 208b.	Enclosed tanks, wood. Fig. 208c.
	Ft.	Ft.			
10,000	10	14½	\$1000-1200	.....	.....
20,000	12	18	1200-1500	.....	.....
30,000	14	21	1500-1800	\$1500-1700	\$1800-2100
40,000	16	22	1800-2200	2200-2600	2300-2800
50,000	16	25	2600-3000	3000-3500	3300-3800
60,000	16	27	3500-3800	3800-4300	4300-4800

NOTE. — In the above cost no allowance is made for supply pipes, waste and drainage; these generally are included in the estimate of water supply.

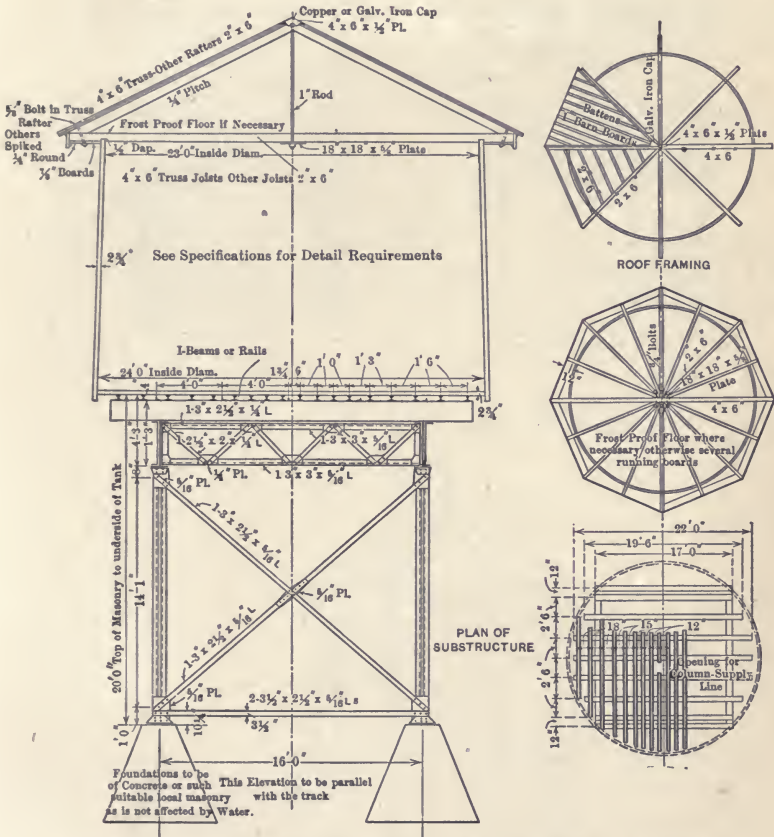

Fig. 207. A. R. E. A. Recommended Wooden Tank. Capacity 50,000 U. S. Gallons.

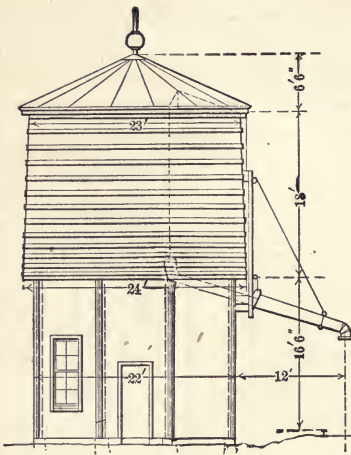

Fig. 208a.

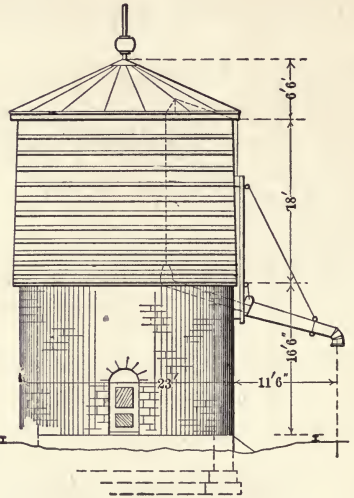

Fig. 208b.

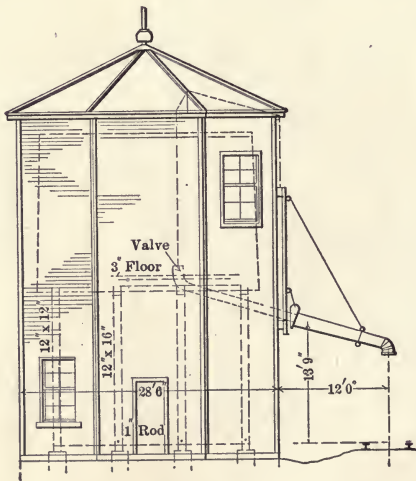

Fig. 208c.  
Water Tanks.



The C. P. R. standard enclosed type of water tank illustrated, Fig. 209, is used at points where climatic conditions are severe, and where it is necessary to provide protection for winter service.

A concrete foundation supports a 12-post structure and an ordinary water tank; around this is built a frame enclosure which is roofed in and double sheathed on the outside, and a stove is generally provided for heating purposes.

The approximate cost of this structure is about \$3500, complete in place.

A brief description of a 50,000-gal. enclosed water tank, the C. P. R. standard, is as follows:

*Foundations.* — Masonry or concrete piers under each post, 1 ft. 6 in. square at top and 4 ft. square at bottom, depth 5 ft. The piers of the outer posts are extended to catch the foundation sills of the housing.

*Posts.* — Outer 12"  $\times$  12", inner 12"  $\times$  16" upright, well braced and tied with rods, 12"  $\times$  12" framing and 12"  $\times$  16" cross beams, with oak corbels at top of posts and 4"  $\times$  12" joists over, covered with 3-in. plank.

*Tub.* — 16-ft. staves, bottom outside diameter 24 ft., top outside diameter 23 ft., cedar staves 3 in. thick with iron bands at varying intervals on the outside.

*Housing.* — The housing consists in building an ordinary frame structure around the tank, supported on cedar sills resting on the foundation piers. The walls are octagon-shaped, set back to get 18 in. clear at the tub, studs 2"  $\times$  6" at 2-ft. centers, doubled at corners, with 4"  $\times$  6" wall plates, and 2"  $\times$  6" stiffeners, and double boarding on the outside with building paper between. The roof is made of 2"  $\times$  6" rafters and ties, covered on the outside with T. & G. boarding and shingles or ready roofing on top. The frame is held to the main posts of the tank with 2"  $\times$  6" braces.

*Fixtures.* — The fixtures consist of a tank valve and outlet pipe with elbow, to which is attached a sway pipe with hold-fasts, pull chain, hangers, counterweights, sheaves, eyebolts, guide pipes, valve rod, indicator, pulley, chains, sheaves and float.



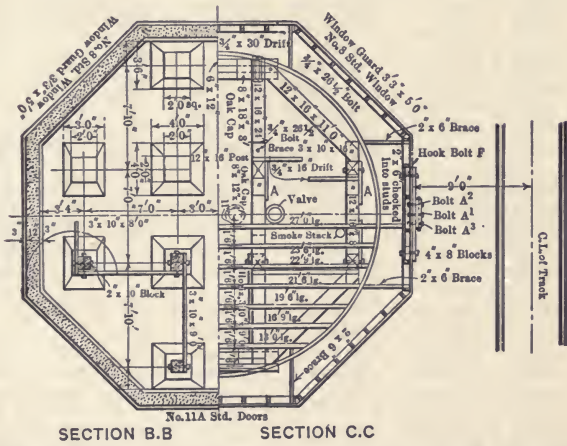
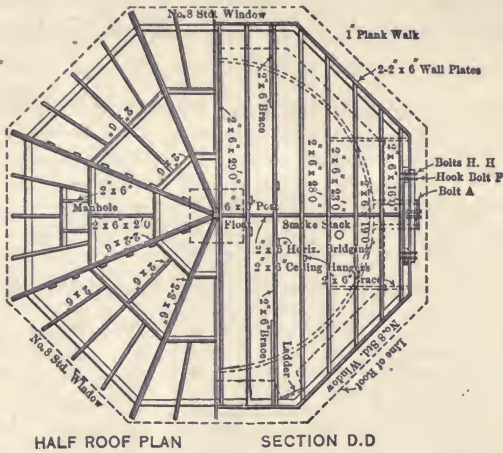

Fig. 209 (Continued). C. P. R. Standard Water Tank. Capacity 50,000 U. S. Gallons.

The approximate cost of a number of water storage tanks obtained from 12 railroads as given by the A. R. E. A. are as follows:

TABLE 117. — APPROXIMATE COST OF WATER TANKS.

No.	Rated capacity, gals.	Construction materials.			Costs (approx. average).			
		Foundation.	Tower.	Tank.	Foundation.	Super- struc.	Total.	Per M. gal.
1	10,000	Concrete....	18' timber....	Wood	\$ 75	\$ 660	\$ 735	\$73.50
2	30,000	Concrete....	13' timber....	Wood	120	1150	1270	42.33
3	32,000	Stone.....	18' timber....	Wood	195	1102	1297	40.53
4	47,000	Concrete....	Timber.....	Wood	497	1665	2162	46.00
5	47,000	Concrete....	Timber.....	Wood	248	2008	2256	48.00
6	47,300	Stone.....	18' timber....	Wood	438	1312	1750	37.00
7	48,600	Stone.....	18' timber....	Wood	400	1204	1604	33.00
8	48,600	Piles.....	18' timber....	Wood	95	1266	1361	28.00
9	50,000	Concrete....	16' timber....	Wood	396	1404	1800	36.00
10	50,000	Concrete....	32' timber....	Wood	420	1680	2100	42.00
11	50,000	Concrete....	Timber.....	Wood	200	1300	1500	30.00
12	50,000	Concrete....	22' timber....	Wood	196	1204	1400	28.00
13	50,000	Concrete....	12' timber....	Wood	300	1200	1500	30.00
14	50,000	Concrete....	17' timber....	Wood	312	1488	1800	36.00
15	50,000	Concrete....	27' timber....	Wood	312	1688	2000	40.00
16	50,000	Concrete....	16' steel.....	Wood	255	2095	2350	47.00
17	50,000	Concrete....	32' steel.....	Wood	275	2475	2750	55.00
18	50,000	Concrete....	Steel.....	Wood	424	1704	2128	42.56
19	47,000	Concrete....	Brick.....	Wood	730	2466	3196	68.00
20	47,000	Concrete....	Brick.....	Wood	1952	2466	4418	94.00
21	50,000	Concrete....	Brick.....	Wood	*1300	1200	2500	50.00
22	100,000	Concrete....	Steel.....	Wood	900	2100	3000	30.00
23	50,000	Concrete....	16' steel.....	Steel	255	2295	2550	51.00
24	50,000	Concrete....	32' steel.....	Steel	265	2685	2950	59.00
25	65,000	Concrete....	Steel.....	Steel	308	2238	2546	39.17
26	†65,000	Concrete....	None.....	Steel	†586	1987	2573	39.59
27	†65,000	Concrete....	None.....	Steel	†869	1987	2856	43.94
28	100,000	Concrete....	Steel.....	Steel	700	2800	3500	35.00
29	†165,000	Concrete....	None.....	Steel	†586	4228	4814	29.18
30	†165,000	Concrete....	None.....	Steel	†869	4228	5097	30.89

\* No. 21 — Foundation cost includes tower.

† Nos. 26, 27, 29 and 30; standpipe type capacity above the twelve-foot line. Costs are for warm and cold climates respectively.

In some locations it is convenient to place the pumping outfit in the enclosure under the tank, and when this is done the layout as shown on Fig. 210 is usually adopted, when the enclosed type of tank is used.

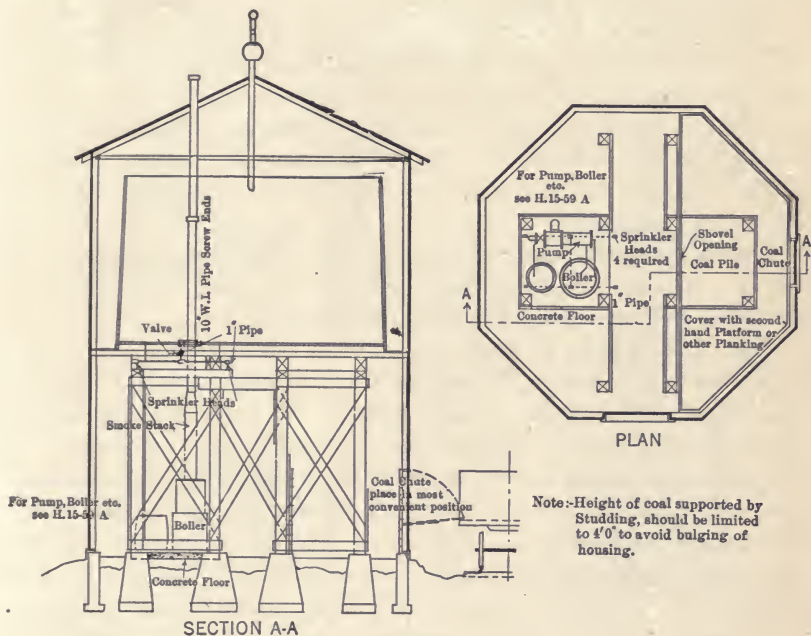

Fig. 210.

In many situations it is often desirable to place the tank away from the track and to feed to the locomotive through a standpipe. The discharge in U. S. gallons per minute from water tank to standpipe for various supply pipes is given in Table 115, page 437.

### Steel Tanks.

The necessity for tanks of large capacity and the scarcity and high cost of select timber for wooden tanks has brought about the development of the steel tank.

The conical bottom type of steel tank, Fig. 212, on account of its adaptability to act as a settling basin for the purpose of precipitating matter carried in suspension, and the ease with which the resultant sludge can be washed out without interrupting service, has made it very satisfactory for railway water supply storage and a number of roads have adopted this type of tank as standard.

The design combines strength, durability and pleasing appearance. All surfaces, both inside and outside, are open for inspection, and are easily accessible for painting.

The tank is built of large diameter, and shallow depth, so as to reduce the variation in pressure to the lowest practical limits. The large riser acts as an inlet pipe to the tank and also as a settling basin for any sediment in the water. It is equipped at the extreme bottom with a washout valve, so that the sediment can be washed out at any time without emptying the tank and interrupting its service. The outlet pipe extends several feet above the bottom of the large riser so that only clear water is drawn off. The riser pipe is made large enough so as to prevent freezing under regular working conditions, and eliminates under ordinary conditions the need of any temporary wooden frost casing. The fact that the large riser is riveted directly to the flexible tank bottom obviates the need of any expansion joint.

For locations where the temperature will fall below 20 degrees below zero or for isolated cases where the service is intermittent and irregular, the use of a stove is recommended for heating the tank. This can be accomplished by raising the bottom of the large riser about 7 ft. 6 in., which will provide sufficient space for the heating stove; around this space a double wooden frost casing should be provided extending from the top of the center foundation pier to the tank bottom. The casing would consist of two thicknesses of  $\frac{7}{8}$ -in. boards and two layers of heavy tarred roofing felt with a 4-in. dead air space

outside the steel riser. The stove pipe would extend from the raised bottom of the large riser up through the tank to about 1 ft. 6 in. above the apex of the roof.

In addition to the stove pipe there are two additional pipes run through the tank to convey the intense hot air from the stove in the lower portion to the roof portion of the tank, and to conserve this heat as much as possible the roof is insulated in-

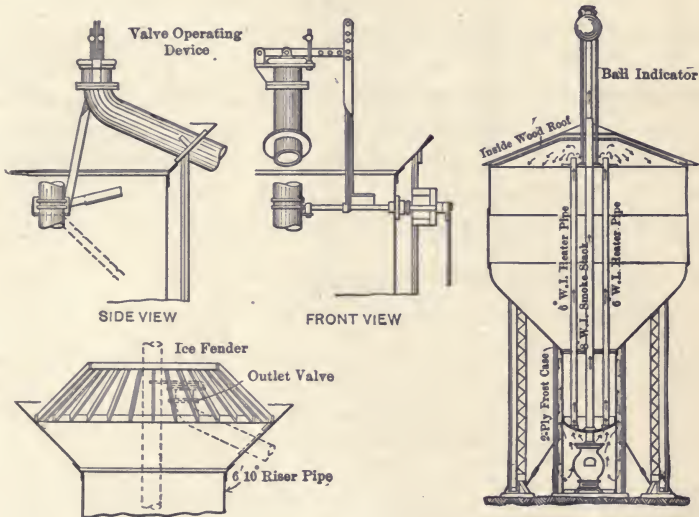

Fig. 211.

side with double boarding and tar paper between; the lower chamber under the tank is also insulated in the same manner. (Fig. 211.)

An ice fender is used to protect the valve from being jammed or damaged by floating ice, when locomotives are taking water.

*Cost of Steel Water Tanks.* — The cost of the steel tanks will vary according to location, the distance it has to be transported, and the kind of labor available. For ordinary conditions, the following prices for various sizes of tanks are a fair average:

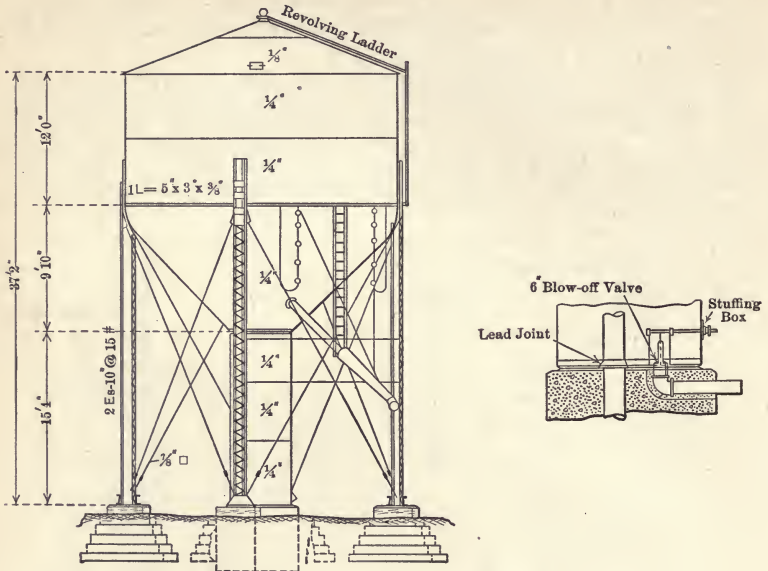

Fig. 212. Capacity 50,000 U. S. Gal. 22 Ft. Diam.

TABLE 118. — COST OF STEEL WATER TANKS.  
(Height from top of rail to valve outlet on tank 20 ft.)

Capacity of tank, U. S. gallons.	Cost of tank and foundation.	10-in. spout and outlet fixtures.	If large riser is frost cased.	Engineering and contingencies.	Total cost.
50,000	\$2600	\$150	\$175	\$275	\$3200
60,000	2860	150	175	315	3500
70,000	3100	150	175	370	3800
80,000	3415	150	175	360	4100
100,000	3850	150	175	428	4600
150,000	5315	150	175	560	6200
200,000	6600	150	175	675	7600

Above prices are for the material and the erection of the tank complete, ready for the connection of the service pipes; if it is desired to house in under the tank to accommodate a pumping outfit, an additional \$350 should be added to the above figures.



## Pumps.

**Water Pumping.** — To ascertain the most economical outfit for pumping water at any proposed water station necessitates a study of the surrounding conditions and requirements before the most suitable type of plant can be determined.

Its economy depends upon the proper proportioning of the suction and discharge pipes and the ratio of steam and water cylinders under working pressure.

The working pressures vary according to the height and distance the water has to be pumped.

*Steam Pumps.* — The duplex steam pump with vertical boiler when properly set up on solid foundation and anchored to work without vibration is thoroughly satisfactory.

Its first cost is a good deal less than the gasoline, oil, or electric outfit, and for ordinary conditions the following is a fair average.

TABLE 119. — STEAM PUMPS AND BOILERS.  
TABLE OF CAPACITIES.

Capacity, U. S. gallons per min.	Duplex pumps.				Pipes.				Boilers.				
	Head feet.	Steam.	Water.	Stroke.	Suction.	Discharge.	Steam.	Exhaust.	H.P.	Diameter.	Height.	2" Tubes.	
												No.	Length.
100	100	6	5	7	5	4	1	1½	10	30	72	54	27
150	150	7	5	10	5	4	1	1½	15	36	84	68	38
200	200	8	5	12	6	5	2	2½	20	42	96	85	48

*Combined Pumps.* — For large supply gasoline or oil is very economical. The combined pumper is very successful and satisfactory in many situations.

There may be no saving in using oil or gasoline instead of coal when the labor of the operator cannot be used in connection with other work.

When gasoline is used and the pump is placed under the tank, stoves may have to be used during winter months to keep pump and water from freezing.

The cost of the fuel for fire purposes under tank would be approximately:

For coal.....	\$20.00
For labor.....	58.00
Total.....	\$78.00 or \$13.00 per month

TABLE 120. — COMBINED GASOLINE ENGINES AND PUMPS.

H.P.	Adjustable stroke.	Cylinders.	Gallons per minute.	Feet head.	Suction.	Discharge.
8	8, 9, 10	5-7	66½-146	145-319	4	4
10	8, 10, 12	7-8½	133-295	90-200	6	5
15	8, 10, 12	7-8½	140-310	127-281	6	5

## COMPARISON ESTIMATES OF STEAM, OIL, AND GASOLINE.

*Conditions.* — Pump to deliver 200 gal. per minute working 10 hours per day and 300 days per year, against an equivalent head of 200 ft. or 10 theoretical horsepower.

## STEAM PUMP AND BOILER.

One 8" × 5" × 12" pump and boiler complete, from Table 121....	\$540.00
Connections and contingencies.....	60.00
Total.....	<u>\$600.00</u>

*Cost of Operating.* —

Assuming 20 pounds of coal per horsepower hour = 200 pounds × 10 hours = 1 ton × 300 = 300 tons per year at \$2.25.....	\$675.00
Attendance by station agent or portion of a regular pumpman's time at \$10 per month.....	120.00
Oil and waste.....	25.00
Repairs and maintenance.....	50.00
Total per year.....	<u>\$870.00</u>

or \$2.90 per day, or 29 cents per hour, or about 2½ cents per 1000 gal. If necessary to have a pumpman all the time, \$300 more would have to be added for his wages, making the cost about 3¼ cents per 1000 gal.

## OIL COMBINED PUMPER.

8" × 12" pump direct connected, from Table 122.....	\$1200.00
Connections and contingencies.....	120.00
	<u>\$1320.00</u>

*Cost of Operating.* —

Coal oil 15 cents per gallon.	
Assuming 1½ cents worth of coal oil per horsepower per hour, including waste and handling = 10 × 1½ = 15¢ × 10 = \$1.50 × 300	\$450.00
Attendance by station agent or portion of a regular pumpman's time at \$10 per month.....	120.00
Lubricating oil and waste.....	30.00
Repairs and maintenance.....	90.00
Total.....	<u>\$690.00</u>

or \$2.30 per day, or 23 cents per hour, or 1.9 cents per 1000 gal. If necessary to have a pumpman all the time, \$300 more would have to be added for his wages, making the cost about 2¾ cents per 1000 gal.

GASOLINE COMBINED PUMPER.

8" x 12" pump direct connected, from Table 122.....	\$1200.00
Connections and contingencies.....	120.00
	<u>\$1320.00</u>

Cost of Operating. —

Gasoline 18 cents per gallon.	
Assuming $\frac{1}{10}$ imperial gallon per horsepower hour = 1 gallon =	
18¢ x 10 = \$1.80 x 300.....	\$540.00
Attendance by station agent or portion of a regular pumpman's	
time at \$10 per month.....	120.00
Lubricating oil and waste.....	30.00
Repairs and maintenance.....	90.00
	<u>\$780.00</u>

or \$2.60 per day, or 26 cents per hour, or 2.2 cents, about, per 1000 gal. If necessary to have a pumpman all the time, \$300 more would have to be added for his wages, making the cost about 3 cents per 1000 gal.

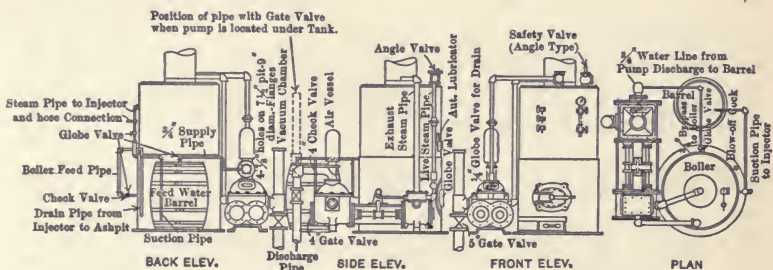

Steam Pump and Boiler Layout.

It will be noted from the foregoing that the approximate cost of pumping water is as follows:

Oil engine.....	1.9 to 2.75 cents per 1000 gal.
Gasoline engine.....	2.2 to 3.00 cents per 1000 gal.
Steam pump and boiler.....	2.5 to 3.25 cents per 1000 gal.

There are many elements that enter into the cost of pumping water that may bring the figures up to double the amounts given. The sizes of suction and discharge pipes are quite as important as the pumps, and if these are figured too small, poor results will be obtained at an additional cost.

The question of using oil, gasoline, or steam depends a good deal on the location and existing conditions and the means at hand for having them looked after in case of repairs. Fuel supply, including depreciation and first cost, has also to be considered.

TABLE 121. — APPROXIMATE COST OF DUPLEX STEAM PUMPS AND BOILERS FOR RAILWAY SERVICE.

Capacity U. S. gal- lons, 100 strokes per min.	Equiva- lent.		Pumps.			Pipes.				Approx. cost of pumps.	Boilers.					Approx. cost of boiler.	Approx. total cost pump and boiler in place.
	Head.	Press.	Steam.	Water.	Stroke.	Suction.	Discharge.	Steam.	Exhaust.		H.P.	Diameter.	Height.	2-in. tubes.			
														Number.	Length.		
	Ft.	Lb.	In.	In.	In.	In.	In.	In.	In.		In.	In.	In.	In.			
65	185	80	6	4	6	4	3	1	1½	\$100	5	24	60	31	18	\$105	\$250
102	115	50	6	5	6	4	3	1	1½	120	5	24	60	31	18	105	270
119	115	50	6	5	7	5	4	1	1½	135	10	30	72	54	27	150	350
119	155	68	7	5	7	5	4	1	1½	150	10	30	72	54	27	150	360
136	115	50	6	5	8	5	4	1	1½	160	10	30	72	54	27	150	380
136	155	68	7	5	8	5	4	1	1½	170	12	30	84	54	38	160	400
170	155	68	7	5	10	5	4	1	1½	240	15	36	84	68	38	190	500
171	110	47	7	6	7	5	4	1	1½	200	10	30	72	54	27	150	420
171	145	63	8	6	7	5	4	2	2½	230	15	36	84	68	38	190	510
204	205	89	8	5	12	5	4	2	2½	260	20	42	96	85	48	230	600
232	80	35	7	7	7	6	5	1½	2	200	10	30	72	54	27	150	420
244	110	47	7	6	10	5	4	1½	2	260	15	36	84	68	38	190	540
244	145	62	8	6	10	5	4	2	2½	270	20	42	96	85	48	230	600
266	105	46	8	7	8	5	4	1½	2	280	15	36	84	68	38	190	570
266	165	71.4	10	7	8	5	4	2	2½	320	20	42	96	85	48	230	660
283	145	62	8	6	12	5	4	2	2½	290	20	42	96	85	48	230	630
283	225	98	10	6	12	5	4	2	2½	310	40	48	114	128	57	420	880
283	325	140	12	6	12	5	4	2½	3	460	50	54	114	174	57	660	1350
332	80	35	7	7	10	6	5	1½	2	300	15	36	84	68	38	190	600
398	105	45	8	7	12	6	5	1½	2	315	20	42	96	85	48	230	660
398	165	71.4	10	7	12	6	5	2	2½	370	40	48	114	128	57	420	950
398	240	103	12	7	12	6	5	2½	3	460	50	54	114	174	57	660	1350
398	325	140	14	7	12	6	5	2½	3	530	70	54	Hor.	40	192	770	1560
522	80	35	8	8	12	6	5	1½	2	510	20	42	96	85	48	230	900
522	125	54	10	8	12	6	5	2	2½	530	40	48	114	128	57	420	1140
522	182	78.75	12	8	12	6	5	2½	3	540	50	54	114	174	57	660	1440
522	250	108	14	8	12	6	5	2½	3	590	70	54	Hor.	40	192	770	1650
522	325	140	16	8	12	6	5	2½	3	690	100	66	Hor.	60	192	1050	2100
816	50	22	8	10	12	6	5	2	2½	570	20	42	96	85	48	230	960
816	115	50	12	10	12	6	5	2½	3	600	50	54	114	174	57	660	1520

TABLE 122. — APPROXIMATE COST, GASOLINE COMBINED PUMPS.

Horse- power.	Adjust- able stroke, inches.	Strokes per minute.	Cylinder, inches.	Gallons per minute, pump dis- placement.	Ft. head.	Suc- tion.	Dis- charge.	Approxi- mate cost in place.
5	8, 9, 10	91	4½-7	51-137	96-259	3-4	3-4	\$ 600
8	8, 9, 10	97½	5-7	66½-146	145-319	4	4	900
10	8, 10, 12	100	7-8½	133-295	90-200	6	5	1200
15	8, 10, 12	105	7-8½	140-310	127-281	6	5	1600
20	8, 10, 12	110	7-8½	147-324	163-360	6	5	2000
25	8, 10, 12	109½	8-10½	215-494	134-356	7	6	2300

**Pumps.** — When practicable the pump is placed under the tank, or in a separate pump house when the source of supply renders it necessary.

The pump may be operated by air, motor, steam, gasoline, oil, gas, or electric motor, and in some instances by the hydraulic ram driven by the fall or force of running water.

The most popular in common use is the duplex type of steam pump, with an independent vertical boiler to supply steam to operate the pump, or a steam pipe is run from the local boiler house when convenient and the pump boiler dispensed with.

The gasoline direct-connected combined pumper is also favored to a large extent, and also the electric-driven motor where power is cheap.

When selecting or investigating a pump, the following information is necessary:

- (a) Maximum quantity of water to be pumped per minute.
- (b) Height to be lifted by suction.
- (c) Length and diameter of suction pipe and number of angles or turns.
- (d) Height to which water has to be forced, from pump to top of tank.
- (e) Length and diameter of delivery pipe and number of angles or turns.
- (f) Pressure of steam to be used.

When the above information is known the following should be estimated:

- (a) Capacity (Table 123).
- (b and d) Lift (Table 126).
- (c and e) Pipe friction (Table 127).
- (f) Power to be provided to raise the water, to overcome the friction of the water in pipes, and bends, and to overcome the friction in pump, and connections to the engine.

The lift and pipe friction pressures equal the total pressure against which the pump has to work, and the area of the water cylinder multiplied by this pressure equals the total resistance.

The area of the power cylinder multiplied by the working pressure equals the total power pressure, and the ratio of power to resistance must be sufficient to move the piston at the required speed. For this, an excess of 33 to 50 per cent is usually allowed. When the capacity, lift, and friction heads are figured, the power necessary to drive the pump may be obtained from Table 124.

As it is not necessary to deliver the water to the tank at high pressure, steam economy is obtained when the ratio of steam and water piston area is proportioned for the actual conditions, using, of course, the nearest commercial size pump.

*Example.* — *A* equals 200 gal. per minute; *B*, 15 ft. (pump set directly over well); *C*, suction pipe 5 in. diameter, 15 ft. deep in well, one elbow; *D*, 45 ft.; *E*, 4 in. diameter, delivery pipe 5000 ft. in length, two elbows; *F*, 80 lb. boiler pressure.

Lift or actual head (*B* + *D*) = 15 + 45..... equals 60 ft.  
 Pipe friction (*C*) 5-in. pipe 15 ft. long

(Table 127)  $0.42 \times \frac{15}{100}$ ..... equals 0.063  
 1 5-in. elbow (Table 128)..... equals 0.068  
 (*E*) 4-in. pipe 5000 ft. long + 60 ft.  
 = 5060 ft. =  $1.22 \times \frac{5060}{1000}$ ..... equals 61.732  
 2 4-in. elbows =  $0.172 \times 2$ ..... equals 0.344  
 Total pipe friction..... equals 62.207

Equivalent height of water for friction  
 pressure =  $62.207 \times 2.3^*$ ..... equals 143 ft.  
 Total head against which the pump  
 has to work..... equals 203 ft.

Referring to Table 121, under 205 ft. head an 8" × 5" × 12" pump is given.

*Power.* — Horsepower necessary to raise water (Table 124)

$$= \frac{200 \times 8\frac{1}{3} \times 203}{33,000} = 10.3 \text{ horsepower.}$$

Pump friction, back pressure,  
 and steam losses say 40 per cent = 4.12 horsepower.  
 Total, 14.42 horsepower.

\* 2.3 = height of water for 1 pound per square inch pressure.

*Engine Horsepower.* — Assuming that the engine is running 100 strokes per minute, and (*F*) 80 lb. boiler pressure, cutting off one-fourth stroke.

$$\text{Horsepower} = \frac{47.7 \times 1 \text{ ft.} \times 2 \times 50.26 \times 100}{33,000} = 14.5.$$

Lift and pipe friction pressure	= (203 ft.) = 87.93 lb.
Area of water cylinder (5 in.)	= 19.63.
Total resistance = 19.63 × 87.93	= 1735 lb.
Area of steam cylinder (8 in.)	= 50.26.
Working pressure	= 47.7 lb.
Total power pressure	= 50.26 × 47.7 = 2397 lb.
Ratio of power to resistance	= 1.4 to 1, or 40 per cent.

**Capacity.** — The capacity of a pump depends upon the speed at which it can be run, and the speed depends largely upon the arrangement of valves and passageways for water and steam; ordinarily it is reckoned by the gallons per minute the pump plunger can deliver at the average speed of piston travel.

For short-stroke pumps, generally used in railroad water tank service, the piston travel may be rated at 100 strokes per minute.

$$\text{Capacity per stroke in gallons} = \frac{\text{stroke} \times \text{area}}{231}.$$

231 = cubic inches in a gallon of water.

TABLE 123. — CAPACITY OF PUMPS PER STROKE IN GALLONS (ONE PLUNGER).

Diameter, water cylinder.	Area, water cylinder.	Length of stroke in inches.								
		5	6	7	8	9	10	12	14	16
In.	Sq. in.									
4	12.56	0.272	0.326	0.381	0.435	0.489	0.544	0.652	0.761	0.870
5	19.63	0.425	0.51	0.595	0.68	0.765	0.85	1.02	1.19	1.36
6	28.27	0.612	0.734	0.877	0.979	1.101	1.224	1.468	1.713	1.958
7	38.48	0.833	0.999	1.166	1.332	1.499	1.666	1.999	2.332	2.665
8	50.26	1.088	1.305	1.523	1.740	1.958	2.176	2.611	3.046	3.481
9	63.61	1.377	1.652	1.928	2.203	2.478	2.764	3.304	3.855	4.406
10	78.54	1.7	2.04	2.38	2.72	3.06	3.4	4.08	4.76	5.44
11	95.03	2.057	2.464	2.879	3.291	3.725	4.113	4.936	5.759	6.582
12	113.09	2.448	2.937	3.422	3.916	4.406	4.896	5.875	6.854	7.833
14	153.93	3.331	3.997	....	5.33	5.996	6.663	7.994	9.328	10.66
15	176.71	3.824	4.589	....	6.119	6.884	7.649	9.178	10.70	12.23
16	201.06	4.35	5.22	....	6.96	7.83	8.703	10.44	12.18	13.92

Gallons delivered in one minute equal capacity per stroke multiplied by strokes per minute. For duplex piston or plunger, multiply by 2. For triplex piston or plunger, multiply by 3.

*Example.* — What quantity of water is delivered per minute with a duplex pump 5-in. water and 7-in. stroke, piston speed 100 strokes per minute? *Ans.*  $0.595 \times 2 \times 100 = 119$  gal. per minute.

*Speed.* — A piston travel of 100 ft. per minute is the basis generally used for rating the capacity of a pump. If short-stroke pumps, however, are run at this speed they would not be durable for every-day service, and 100 strokes rather than 100 ft. is a more reasonable service. Even this is high for railway service; 50 to 75 ft. is nearer the mark.

At a piston speed of 100 ft. per minute the pump would have to make the following strokes:

Three-inch stroke pump, 400 strokes per minute.

Four-inch stroke pump, 300 strokes per minute.

Five-inch stroke pump, 240 strokes per minute.

Six-inch stroke pump, 200 strokes per minute.

Seven-inch stroke pump, 171+ strokes per minute.

Eight-inch stroke pump, 150 strokes per minute.

Nine-inch stroke pump, 133+ strokes per minute.

Ten-inch stroke pump, 120 strokes per minute.

Eleven-inch stroke pump, 109+ strokes per minute.

Twelve-inch stroke pump, 100 strokes per minute.

A steam pump and boiler layout as used by the C. P. R. in many installations of this kind is shown on page 451. The boiler, steam pump and feedwater barrel are nested together to take up as little space as possible and to economize in piping and fixtures.



Theoretical Horsepower.

Theoretical horsepower necessary to raise water any height

$$= \frac{\text{gallons per minute} \times 8.33 \times \text{height in feet}}{33,000}$$

= horsepower per minute.

8.33 = weight of a gallon of water.

33,000 = number of foot-pounds per minute in one horsepower.

TABLE 124. — THEORETICAL HORSEPOWER TO RAISE WATER TO DIFFERENT HEIGHTS.

U. S. gallons per minute.	U. S. gallons per hour.	Height in feet.								
		20	25	30	35	40	45	50	60	75
20	1,200	0.100	0.125	0.150	0.175	0.20	0.22	0.25	0.30	0.37
25	1,500	0.125	0.156	0.187	0.219	0.25	0.28	0.31	0.37	0.47
30	1,800	0.150	0.187	0.225	0.262	0.30	0.34	0.37	0.45	0.56
35	2,100	0.175	0.219	0.262	0.306	0.35	0.39	0.44	0.52	0.66
40	2,400	0.200	0.250	0.300	0.350	0.40	0.45	0.50	0.60	0.75
45	2,700	0.225	0.281	0.337	0.394	0.45	0.51	0.56	0.67	0.84
50	3,000	0.250	0.312	0.375	0.437	0.50	0.56	0.62	0.75	0.94
60	3,600	0.300	0.375	0.450	0.525	0.60	0.67	0.75	0.90	1.12
75	4,500	0.375	0.469	0.562	0.656	0.75	0.84	0.94	1.12	1.40
90	5,400	0.450	0.562	0.675	0.787	0.90	1.01	1.12	1.35	1.68
100	6,000	0.500	0.625	0.750	0.875	1.00	1.12	1.25	1.50	1.87
125	7,500	0.625	0.781	0.937	1.094	1.25	1.41	1.56	1.87	2.34
150	9,000	0.750	0.937	1.125	1.312	1.50	1.69	1.87	2.25	2.81
175	10,500	0.875	1.093	1.312	1.531	1.75	1.97	2.19	2.62	3.28
200	12,000	1.00	1.25	1.50	1.75	2.00	2.25	2.50	3.00	3.75
250	15,000	1.25	1.562	1.875	2.187	2.50	2.81	3.12	3.75	4.69
300	18,000	1.50	1.875	2.25	2.625	3.00	3.37	3.75	4.50	5.62
350	21,000	1.75	2.187	2.625	3.062	3.50	3.94	4.37	5.25	6.56
400	24,000	2.00	2.5	3.00	3.50	4.00	4.50	5.00	6.00	7.50
500	30,000	2.25	3.125	3.75	4.375	5.00	5.62	6.25	7.50	9.37
			90	100	125	150	175	200	250	300
20	1,200	0.45	0.50	0.62	0.75	0.87	1.00	1.25	1.50	
25	1,500	0.56	0.62	0.78	0.94	1.09	1.26	1.56	1.87	
30	1,800	0.67	0.75	0.94	1.12	1.31	1.50	1.87	2.25	
35	2,100	0.79	0.87	1.08	1.31	1.53	1.75	2.19	2.62	
40	2,400	0.90	1.00	1.25	1.50	1.75	2.00	2.50	3.00	
45	2,700	1.01	1.12	1.41	1.69	1.97	2.25	2.81	3.37	
50	3,000	1.12	1.25	1.56	1.87	2.19	2.50	3.12	3.75	
60	3,600	1.35	1.50	1.87	2.25	2.62	3.00	3.75	4.50	
75	4,500	1.69	1.87	2.34	2.81	3.28	3.75	4.69	5.62	
90	5,400	2.02	2.25	2.81	3.37	3.94	4.5	5.62	6.75	
100	6,000	2.25	2.50	3.12	3.75	4.37	5.00	6.25	7.50	
125	7,500	2.81	3.16	3.91	4.69	5.47	6.25	7.81	9.37	
150	9,000	3.37	3.75	4.69	5.62	6.56	7.5	9.37	11.25	
175	10,500	3.94	4.07	5.47	6.56	7.66	8.75	10.94	13.12	
200	12,000	4.50	5.00	6.25	7.50	8.75	10.00	12.50	15.00	
250	15,000	5.62	6.25	7.81	9.37	10.94	12.50	15.72	18.75	
300	18,000	6.75	7.50	9.57	11.25	13.12	15.00	18.75	22.50	
350	21,000	7.87	8.75	10.94	13.12	15.31	17.50	21.87	26.25	
400	24,000	9.00	10.00	12.50	15.00	17.50	20.00	25.00	30.00	
500	30,000	11.25	12.5	15.62	18.75	21.87	25.00	31.25	37.50	

## Engine Horsepower.

$$\text{Horsepower} = \frac{P \times L \times A \times N}{33,000}$$

$P$  = average effective pressure in pounds per square inch.

$L$  = twice the length of piston stroke in feet.

$A$  = area of piston in square inches.

$N$  = the number of revolutions of the crank shaft per minute.

TABLE 125. — AVERAGE STEAM PRESSURE ON PISTON, IN POUNDS PER SQUARE INCH.

Aver. press. throughout the piston stroke. (Initial press. = 1.)	0.966	0.937	0.919	0.846	0.743	0.699	0.596	0.385
Grade of expansion of steam	1½	1½	1½	2	2½	3	4	8
Steam cut-off	¼	¼	¼	½	⅔	⅔	⅔	⅔
Initial steam press., lbs. per sq. in.								
25	24.1	23.4	22.9	21.1	18.5	17.4	19.9	9.6
30	28.9	28.1	27.5	25.3	22.2	20.9	17.8	11.5
35	33.7	32.8	32.1	29.6	25.9	24.4	20.8	13.4
40	38.6	37.4	36.7	33.8	28.9	27.9	23.8	15.3
45	43.4	42.1	41.2	38.0	32.6	31.4	26.8	17.3
50	48.2	46.8	45.9	42.3	37.1	35.0	29.8	19.2
55	53.0	51.3	50.5	46.6	40.8	38.4	32.8	21.2
60	57.8	56.0	55.1	50.8	44.5	41.9	35.8	23.1
65	62.8	60.7	59.7	55.0	48.2	45.4	38.8	24.9
70	67.5	65.3	64.3	59.2	52.4	48.9	41.6	26.7
75	72.3	70.0	68.9	63.5	56.1	52.4	44.7	28.6
80	77.1	75.7	73.5	67.7	59.3	53.9	47.7	30.8
85	81.9	80.3	78.1	72.0	63.0	59.4	50.7	32.7
90	86.7	84.0	82.7	76.2	66.8	62.9	53.7	34.6
95	91.5	88.7	87.3	80.4	70.4	66.4	56.7	36.6
100	96.4	93.3	91.9	84.5	74.2	69.9	59.6	38.5
105	101.2	98.0	96.5	88.9	77.9	73.4	62.6	40.4
110	106.0	101.7	101.0	93.1	81.6	76.9	66.6	42.3
115	110.8	106.3	105.6	97.4	85.2	80.4	69.6	44.2
120	115.6	112.0	110.2	101.6	89.0	83.9	71.6	46.2
125	120.5	115.7	114.8	105.8	102.8	87.4	74.6	48.1

*Example.* — What horsepower will a steam engine 8-in. bore and 12-in. stroke develop at 100 revolutions of the crank shaft per minute, cutting off one-third stroke and having an initial pressure 100 lb.?

$P$ , 100 pounds initial pressure one-third stroke, from table = 69.9, less say 14.9 for back pressure = 55 lb.;  $L$ , twice stroke = 12'' × 2 = 2 ft.;  $A$ , area 8-in. piston = 50.26;  $N$ , 100; hence horsepower of engine

$$= \frac{55 \times 2 \times 50.26 \times 100}{33,000} = 16.8.$$

**Lift.** — The head of water against which the pump has to work, or the pressure due to the height to which the water has to be forced, is usually termed the lift, and expressed in pounds per square inch = height of water column  $\times$  0.434.

0.434 = pound pressure per square inch exerted by a column of water one foot high.

TABLE 126. — FEET HEAD AND EQUIVALENT PRESSURE IN POUNDS PER SQUARE INCH.

Ft. head.	Equip. press. in pounds.	Ft. head.	Equip. press. in pounds.	Ft. head.	Equip. press. in pounds.	Ft. head.	Equip. press. in pounds.	Ft. head.	Equip. press. in pounds.
1	0.43	65	28.15	129	55.88	193	83.60	257	111.32
2	0.86	66	28.58	130	56.31	194	84.03	258	111.76
3	1.30	67	29.02	131	56.74	195	84.48	259	112.19
4	1.73	68	29.45	132	57.18	196	84.90	260	112.62
5	2.16	69	29.88	133	57.61	197	85.33	261	113.06
6	2.59	70	30.32	134	58.04	198	85.76	262	113.49
7	3.03	71	30.75	135	58.48	199	86.20	263	113.92
8	3.46	72	31.18	136	58.91	200	86.63	264	114.36
9	3.89	73	31.62	137	59.34	201	87.07	265	114.79
10	4.33	74	32.05	138	59.77	202	87.50	266	115.22
11	4.76	75	32.48	139	60.21	203	87.93	267	115.66
12	5.20	76	32.92	140	60.64	204	88.36	268	116.09
13	5.63	77	33.35	141	61.07	205	88.80	269	116.52
14	6.06	78	33.78	142	61.51	206	89.23	270	116.96
15	6.49	79	34.21	143	61.94	207	89.68	271	117.39
16	6.93	80	34.65	144	62.37	208	90.10	272	117.82
17	7.36	81	35.08	145	62.81	209	90.53	273	118.26
18	7.79	82	35.52	146	63.24	210	90.96	274	118.69
19	8.22	83	35.95	147	63.67	211	91.39	275	119.12
20	8.66	84	36.39	148	64.10	212	91.83	276	119.56
21	9.09	85	36.82	149	64.54	213	92.26	277	119.99
22	9.53	86	37.25	150	64.97	214	92.69	278	120.42
23	9.96	87	37.68	151	65.40	215	93.13	279	120.85
24	10.39	88	38.12	152	65.84	216	93.56	280	121.29
25	10.82	89	38.55	153	66.27	217	93.99	281	121.73
26	11.26	90	38.98	154	66.70	218	94.43	282	122.15
27	11.69	91	39.42	155	67.14	219	94.86	283	122.59
28	12.12	92	39.85	156	67.57	220	95.30	284	123.02
29	12.55	93	40.28	157	68.00	221	95.73	285	123.45
30	12.99	94	40.72	158	68.43	222	96.16	286	123.89
31	13.42	95	41.15	159	68.87	223	96.60	287	124.32
32	13.86	96	41.58	160	69.31	224	97.03	288	124.75
33	14.29	97	42.01	161	69.74	225	97.46	289	125.18
34	14.72	98	42.45	162	70.17	226	97.90	290	125.62
35	15.16	99	42.88	163	70.61	227	98.33	291	126.05
36	15.59	100	43.31	164	71.04	228	98.76	292	126.48
37	16.02	101	43.75	165	71.47	229	99.20	293	126.92
38	16.45	102	44.18	166	71.91	230	99.63	294	127.35
39	16.89	103	44.61	167	72.34	231	100.00	295	127.78
40	17.32	104	45.05	168	72.77	232	100.49	296	128.22
41	17.75	105	45.48	169	73.20	233	100.93	297	128.65
42	18.19	106	45.91	170	73.64	234	101.36	298	129.08
43	18.62	107	46.34	171	74.07	235	101.79	299	129.51
44	19.05	108	46.78	172	74.50	236	102.23	300	129.95
45	19.49	109	47.21	173	74.94	237	102.66	310	134.23
46	19.92	110	47.64	174	75.37	238	103.09	320	138.62
47	20.35	111	48.08	175	75.80	239	103.53	330	142.95
48	20.79	112	48.51	176	76.23	240	103.96	340	147.28
49	21.22	113	48.94	177	76.67	241	104.39	350	151.61
50	21.65	114	49.38	178	77.10	242	104.83	360	155.94
51	22.09	115	49.81	179	77.53	243	105.26	370	160.27
52	22.52	116	50.24	180	77.97	244	105.69	380	164.61
53	22.95	117	50.68	181	78.40	245	106.13	390	168.94
54	23.39	118	51.11	182	78.84	246	106.56	400	173.27
55	23.82	119	51.54	183	79.27	247	106.99	500	216.58
56	24.26	120	51.98	184	79.70	248	107.43	600	259.90
57	24.69	121	52.41	185	80.14	249	107.86	700	303.22
58	25.12	122	52.84	186	80.57	250	108.29	800	346.54
59	25.55	123	53.28	187	81.00	251	108.73	900	389.86
60	25.99	124	53.71	188	81.43	252	109.16	1000	435.18
61	26.42	125	54.15	189	81.87	253	109.59		
62	26.85	126	54.58	190	82.30	254	110.03		
63	27.29	127	55.01	191	82.73	255	110.46		
64	27.72	128	55.44	192	83.17	256	110.89		

TABLE 127. — FRICTION OF WATER IN PIPES.

Pressure in pounds per square inch to be added for each 100 feet of clean iron pipe.

Gals. per minute delivered.	Pipe sizes.															
	$\frac{3}{4}$	1	1 $\frac{1}{4}$	1 $\frac{1}{2}$	2	2 $\frac{1}{2}$	3	3 $\frac{1}{2}$	4	5	6	7	8	9	10	12
5	3.3	0.84	0.31	0.12	0.04	0.02	.....	.....	.....	.....	.....	.....	.....	.....	.....	.....
10	13.0	3.16	1.05	0.47	0.12	0.04	0.02	.....	.....	.....	.....	.....	.....	.....	.....	.....
15	28.7	6.98	2.38	0.97	0.25	0.08	0.04	0.02	.....	.....	.....	.....	.....	.....	.....	.....
20	50.4	12.3	4.07	1.66	0.42	0.14	0.06	0.03	.....	.....	.....	.....	.....	.....	.....	.....
25	78.0	19.0	6.40	2.62	0.62	0.21	0.10	0.04	0.02	.....	.....	.....	.....	.....	.....	.....
30	.....	27.5	9.15	3.75	0.91	0.30	0.13	0.06	0.03	.....	.....	.....	.....	.....	.....	.....
35	.....	37.0	12.4	5.05	1.22	0.40	0.17	0.09	0.05	0.02	.....	.....	.....	.....	.....	.....
40	.....	48.0	16.1	6.52	1.60	0.53	0.23	0.11	0.06	0.02	.....	.....	.....	.....	.....	.....
45	.....	.....	20.2	8.15	1.99	0.66	0.28	0.14	0.07	0.03	.....	.....	.....	.....	.....	.....
50	.....	.....	24.9	10.0	2.44	0.81	0.35	0.17	0.09	0.04	.....	.....	.....	.....	.....	.....
60	.....	.....	36.0	14.0	3.50	1.17	0.50	0.24	0.13	0.05	0.02	.....	.....	.....	.....	.....
70	.....	.....	48.0	20.0	4.80	1.50	0.60	0.38	0.19	0.07	0.03	.....	.....	.....	.....	.....
75	.....	.....	56.1	22.4	5.32	1.80	0.74	.....	.....	.....	.....	.....	.....	.....	.....	.....
80	.....	.....	64.0	25.0	6.30	2.00	0.90	0.41	0.23	0.08	0.03	.....	.....	.....	.....	.....
90	.....	.....	80.0	32.0	7.80	2.58	1.10	0.54	0.26	0.09	0.04	.....	.....	.....	.....	.....
100	.....	.....	.....	39.0	9.46	3.20	1.31	0.64	0.33	0.12	0.05	0.02	.....	.....	.....	.....
125	.....	.....	.....	.....	14.9	4.89	1.99	0.96	0.49	0.17	0.07	0.03	.....	.....	.....	.....
150	.....	.....	.....	.....	21.2	7.00	2.85	1.35	0.69	0.25	0.10	0.04	.....	.....	.....	.....
175	.....	.....	.....	.....	28.1	9.46	3.85	1.82	0.93	0.34	0.13	0.05	.....	.....	.....	.....
200	.....	.....	.....	.....	37.5	12.47	5.02	2.38	1.22	0.42	0.17	0.07	.....	.....	.....	.....
250	.....	.....	.....	.....	.....	19.66	7.76	3.70	1.89	0.65	0.26	0.12	0.07	0.04	0.03	0.01
300	.....	.....	.....	.....	.....	28.06	11.2	5.04	2.66	0.93	0.37	0.17	0.09	0.05	0.04	0.03
350	.....	.....	.....	.....	.....	.....	15.2	7.40	3.65	1.26	0.50	0.23	0.12	0.07	0.05	0.02
400	.....	.....	.....	.....	.....	.....	19.5	9.25	4.73	1.61	0.65	0.30	0.16	0.09	0.06	0.05
450	.....	.....	.....	.....	.....	.....	25.0	11.70	6.01	2.00	0.81	0.37	0.20	0.11	0.07	0.03
500	.....	.....	.....	.....	.....	.....	30.8	14.5	7.43	2.40	0.96	0.45	0.25	0.14	0.09	0.04
750	.....	.....	.....	.....	.....	.....	.....	.....	.....	.....	2.21	1.03	0.53	0.30	0.18	0.08
1000	.....	.....	.....	.....	.....	.....	.....	.....	.....	.....	3.88	1.80	0.94	0.53	0.32	0.13
1250	.....	.....	.....	.....	.....	.....	.....	.....	.....	.....	6.00	2.85	1.46	0.82	0.49	0.20
1500	.....	.....	.....	.....	.....	.....	.....	.....	.....	.....	8.60	4.08	2.09	1.17	0.70	0.29

Table is based on Ellis' and Howland's experiments. To find "friction head" in feet multiply figures by 2.3.

TABLE 128. — FRICTION OF WATER IN ELBOWS.

Pressure in pounds per square inch to be added for each elbow.

Gals. per minute delivered.	Pipe sizes.															
	$\frac{3}{4}$	1	1 $\frac{1}{4}$	1 $\frac{1}{2}$	2	2 $\frac{1}{2}$	3	3 $\frac{1}{2}$	4	5	6	7	8	9	10	12
5	0.07	0.027	0.008	0.005	0.002	.....	.....	.....	.....	.....	.....	.....	.....	.....	.....	.....
10	0.28	0.094	0.031	0.018	0.006	0.003	.....	.....	.....	.....	.....	.....	.....	.....	.....	.....
15	0.63	0.212	0.069	0.04	0.014	0.005	.....	.....	.....	.....	.....	.....	.....	.....	.....	.....
20	1.12	0.376	0.123	0.069	0.025	0.012	0.005	.....	.....	.....	.....	.....	.....	.....	.....	.....
25	1.74	0.585	0.194	0.108	0.038	0.02	0.008	.....	.....	.....	.....	.....	.....	.....	.....	.....
30	.....	0.845	0.278	0.157	0.055	0.028	0.011	.....	.....	.....	.....	.....	.....	.....	.....	.....
35	.....	1.15	0.380	0.215	0.076	0.037	0.015	0.009	.....	.....	.....	.....	.....	.....	.....	.....
40	.....	1.50	0.495	0.278	0.098	0.049	0.02	0.011	0.007	.....	.....	.....	.....	.....	.....	.....
45	.....	1.90	0.626	0.352	0.125	0.062	0.026	0.015	0.009	.....	.....	.....	.....	.....	.....	.....
50	.....	.....	0.77	0.43	0.153	0.08	0.032	0.017	0.01	.....	.....	.....	.....	.....	.....	.....
60	.....	3.38	1.11	0.62	0.22	0.112	0.044	0.026	0.015	0.006	0.003	.....	.....	.....	.....	.....
70	.....	4.60	1.52	0.86	0.304	0.148	0.06	0.035	0.021	0.009	0.004	0.002	.....	.....	.....	.....
75	.....	5.30	1.74	0.98	0.35	0.172	0.072	0.04	0.024	0.01	0.005	0.003	.....	.....	.....	.....
80	.....	6.00	1.98	1.11	0.392	0.196	0.08	0.044	0.027	0.012	0.005	0.003	.....	.....	.....	.....
90	.....	7.60	2.50	1.41	0.50	0.248	0.104	0.06	0.035	0.014	0.007	0.004	.....	.....	.....	.....
100	.....	.....	3.08	1.72	0.612	0.32	0.128	0.068	0.043	0.017	0.008	0.005	0.003	0.002	.....	.....
125	.....	.....	.....	2.72	0.97	0.48	0.20	0.112	0.067	0.027	0.013	0.007	0.004	0.003	0.002	.....
150	.....	.....	.....	3.92	1.39	0.685	0.286	0.16	0.096	0.039	0.019	0.01	0.006	0.004	0.003	0.001
175	.....	.....	.....	5.32	1.90	0.935	0.390	0.218	0.132	0.053	0.026	0.014	0.009	0.005	0.004	0.002
200	.....	.....	.....	6.88	2.44	1.28	0.512	0.272	0.172	0.068	0.032	0.02	0.011	0.007	0.005	0.002
250	.....	.....	.....	.....	3.86	1.91	0.80	0.446	0.268	0.109	0.052	0.029	0.017	0.011	0.007	0.004
300	.....	.....	.....	.....	5.56	2.74	1.14	0.64	0.384	0.156	0.076	0.042	0.025	0.016	0.01	0.005
350	.....	.....	.....	.....	.....	3.77	1.58	0.88	0.530	0.215	0.103	0.057	0.034	0.022	0.014	0.007
400	.....	.....	.....	.....	.....	5.12	2.05	1.09	0.688	0.272	0.128	0.08	0.044	0.028	0.018	0.009
450	.....	.....	.....	.....	.....	6.20	2.58	1.45	0.870	0.352	0.170	0.094	0.057	0.036	0.023	0.011
500	.....	.....	.....	.....	.....	7.64	3.20	1.78	1.07	0.436	0.208	0.116	0.068	0.044	0.028	0.016
750	.....	.....	.....	.....	.....	.....	.....	.....	2.42	0.970	0.470	0.260	0.156	0.10	0.063	0.031
1000	.....	.....	.....	.....	.....	.....	.....	.....	4.28	1.74	0.832	0.464	0.272	0.176	0.112	0.064
1250	.....	.....	.....	.....	.....	.....	.....	.....	6.70	2.71	1.31	0.728	0.435	0.276	0.175	0.086
1500	.....	.....	.....	.....	.....	.....	.....	.....	9.68	3.88	1.88	0.84	0.624	0.40	0.252	0.124

Table is based on Weisbach's formula for very short bends, or with a radius equal to the radius of the pipe. To find "friction head" in feet multiply figures by 2.3.

**Standpipes.** — There are two kinds of water columns or standpipes in general service, for conveniently supplying locomotives with water at locations remote from the water tank. Both are much alike excepting in the spout which is either telescopic or semi-rigid. The telescopic spout has a vertical movement of about 5 ft., a convenience to accommodate the varying heights of locomotive tenders, and the semi-rigid about 2 ft. The standpipes are made of iron and steel and a great number of styles are produced; in all, however, the essential features consist of a main vertical pipe or column, a bell pedestal base, a spout, the valve mechanism and chamber or pit in which the valves are set. Normally the water column spout stands parallel with the track; on taking water the spout is drawn across

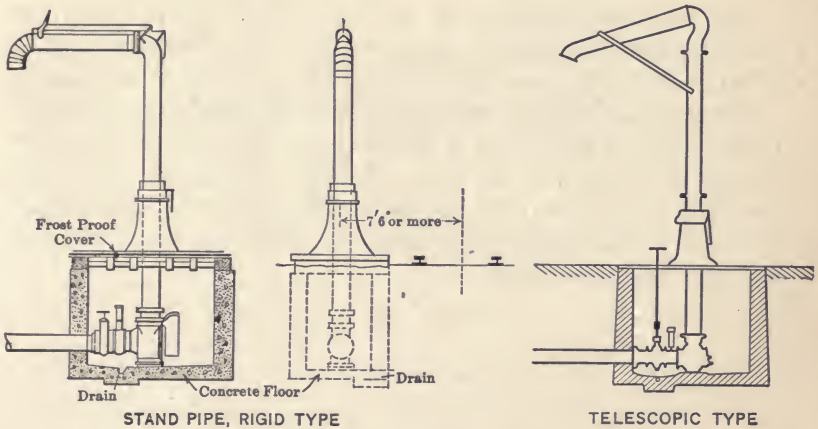

the track, a lever is pulled and the flow is immediate. When sufficient water has been taken the lever is released and the water is automatically cut off, and the spout being released is returned to the position parallel to the track.

As it takes up little room and is arranged to swing clear of the tracks when not in use, it is not considered a serious obstruction.

Standpipes are used very extensively at stations, yards, and other places where convenient for quick service, and are generally located so that one standpipe will serve two tracks.

*Standpipe, Telescopic Type.* — A pipe line from the service water tank the full size of the standpipe is run connecting the

two as direct as possible, so as to render a high velocity supply; sometimes the connection is made with the city or town's high pressure mains and charged by meter.

The standpipes in general use are 6, 8, 10, and 12 in., weighing from 2500 to 5000 lb. each.

APPROXIMATE COST WITHOUT SUPPLY PIPE LINE.

	Wood chamber.	Concrete chamber.
6-inch standpipe complete in place.....	\$300 to \$400	\$400 to \$450
8-inch standpipe complete in place.....	450 to 550	550 to 650
10-inch standpipe complete in place.....	500 to 600	600 to 700
12-inch standpipe complete in place.....	550 to 650	650 to 750

The approximate discharge in U. S. gallons per minute from water tank to standpipe for various supply pipes 1000 feet long is given in Table 115, page 437, for two different types of standpipes.

For example, it is desired to ascertain what will be the discharge from a water tank through a 10-inch supply pipe to the standpipe with 14 ft. of water in the tank. For the 10-inch rigid standpipe the table (115) gives 1700 and for the telescopic 1550 gallons per minute. If the pipe were 12 inches the discharge would be 2600 and 2500 gallons respectively.

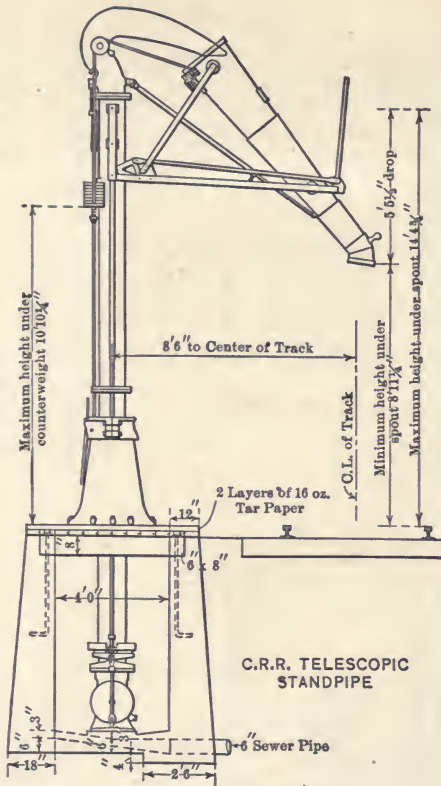

C. P. R. Telescopic Standpipe.

APPROXIMATE ESTIMATE FOR SUPPLY PIPE AND STANDPIPE.—  
SUPPLY PIPE 140 FEET LONG.

Supply pipe:	
Excavation for supply pipe, 110 cubic yards at 75¢ . . .	\$82.50
C. I. pipe, 10-inch supply, 5.26 tons at \$35. . . . .	184.10
Lead for joints, 168 pounds at 8¢ . . . . .	13.44
Laying pipe, 140 lineal feet at 17¢ . . . . .	23.80
Connections . . . . .	10.00
	\$313.84
Standpipe:	
1 10-inch standpipe erected . . . . .	\$420.00
Excavation for pit, 10 cubic yards at 75¢ . . . . .	7.50
Concrete pit . . . . .	100.00
	\$527.50
Drain 5 feet deep:	
Excavation 164 cubic yards at 75¢ . . . . .	\$125.00
210 lineal feet 4-inch tile pipe laid, at 16¢ . . . . .	33.60
Bell trap bends and connections . . . . .	13.40
	\$170.00
	\$1011.34
Supervision and contingencies 10 per cent. . . . .	108.66
Total . . . . .	\$1120.00





Pump Houses.

**C. P. R. Frame Pump House 16' × 32'.** — Fig. 214 illustrates the C. P. R. standard frame pump house for a steam pump and boiler installation. The studs are 2" × 4" at 2 ft. centers, supported on 6-in. flatted cedar sills, covered with  $\frac{7}{8}$ -in. rough boarding, protected with a layer of tar paper and finished with  $\frac{7}{8}$ -in. drop siding. The rafters are also 2" × 4" at 2-ft. centers covered with 1" rough boards and 2-ply ready roofing.

The house is divided into a boiler room 16' × 16' and a coal shed of the same dimensions. The boiler room floor is finished with a layer of cinders and the coal shed floor is covered with 2-in. rough plank.

The approximate cost of the building complete, not including the pump or boiler, is about \$700.

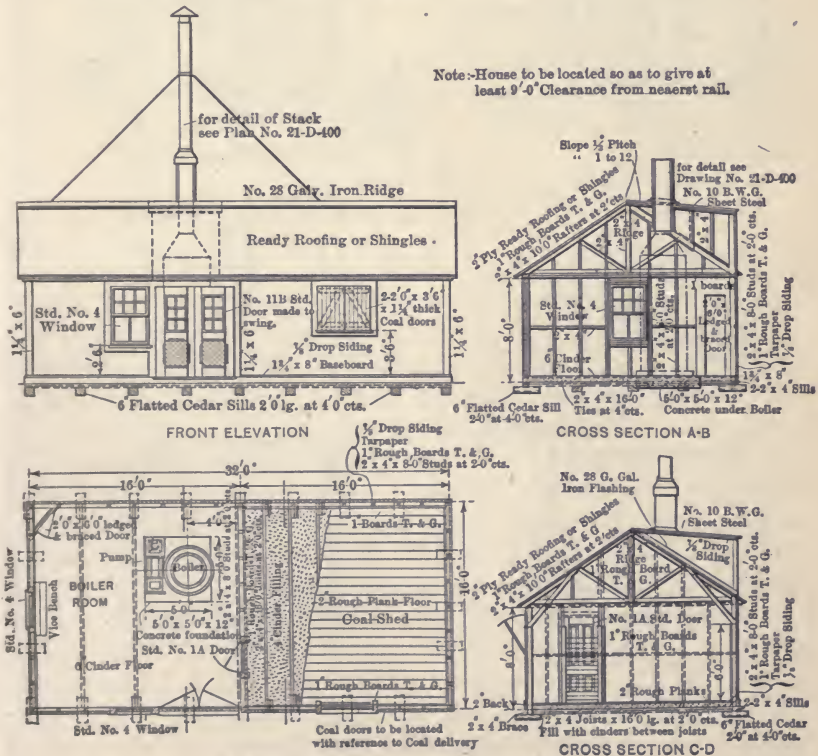

PLAN

Fig. 214. Frame Pump House.

**C. P. R. Frame Pump House 14' x 16'.** — The wooden pump house 14' x 16' shown on Fig. 215 is used for electric pumping outfits. The frame consists of 2" x 4" studs at 2 ft. centers, supported on 6-in. cedar sills and covered with drop siding or corrugated iron. The roof timbers are 2" x 6" at 2-ft. centers, covered with 1-in. rough boards and 2-ply ready roofing.

The approximate cost of this house is about \$275.

**C. P. R. Concrete Pump House 15' x 17'.** — A similar house 15' x 17', Fig. 215a, in concrete with flat roof, would cost about \$450.

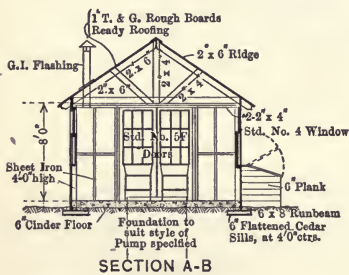

SECTION A-B

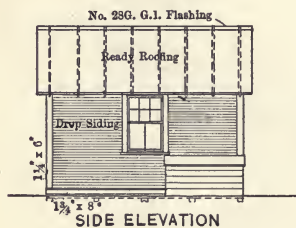

SIDE ELEVATION

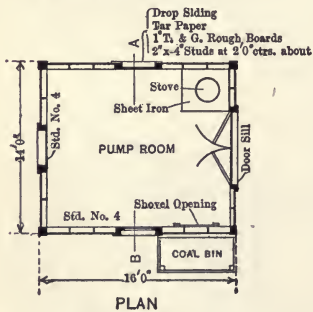

PLAN

Fig. 215.

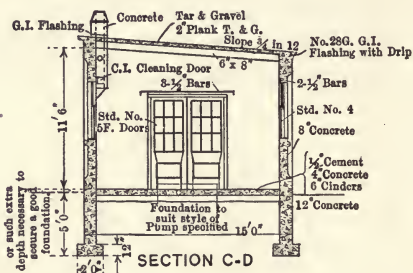

SECTION C-D

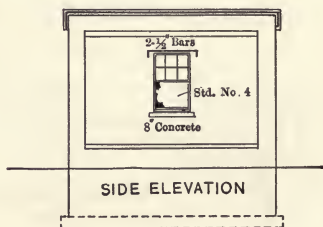

SIDE ELEVATION

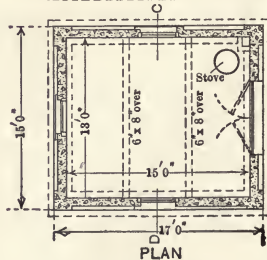

PLAN

Fig. 215a.

Frame and Concrete Pump Houses.

**Concrete Block Pump House, M. St. P. & S. S. M. Ry., 14' × 14'.** — Fig. 216 shows a concrete block pump house built by the M. St. P. & S. S. M. Ry., for gasoline pumping outfit. It is 14 ft. square and the cost would be about \$400. This price will include the pump foundation and tank receptacle, but not the pumping outfit or gasoline tank.

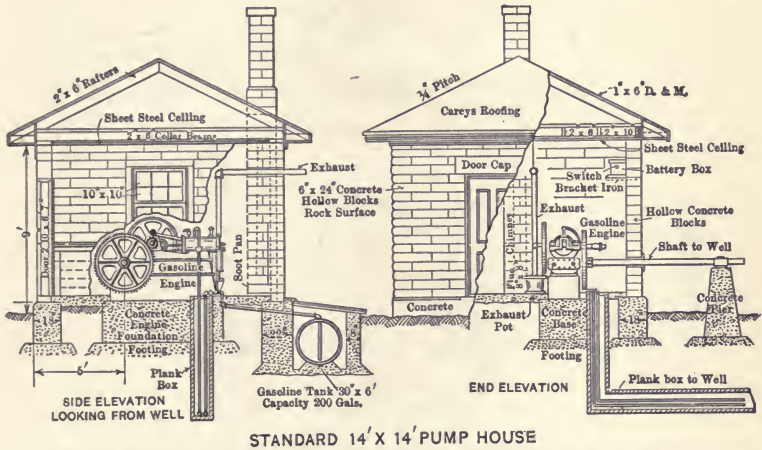

Fig. 216. Concrete Block Pump House, M. St. P. & S. S. M. Ry.

**C. L. O. & W. Ry. Pump House.** — A pump house, built on the C. L. O. & W. Ry. at a number of points, is shown, Fig. 217. The inside dimensions are 10' 7" × 13', to accommodate a 10 horsepower combined gasoline engine and pump. The foundation for the pumping outfit is a solid block of concrete, supported on piles, where soft bottom is encountered and provision is made for a stove and coal bin. A separate pit for gasoline tank is built of concrete with a wooden top, located in a suitable position some distance from the pump house. The pit is drained and is large enough to hold a 50 gallon tank. The house itself is of the ordinary frame construction with 2" × 6" wood joists on cedar sills, finished on top with 2 in. plank for the floor; the wall studs are 2" × 4" at 2-ft. centers and the roof and ceiling timbers 2" × 6". The roof is covered with 7/8-in. T. & G. boards with building paper and shingles over. The walls are double lined with 7/8-in. T. & G. boards and drop siding with building

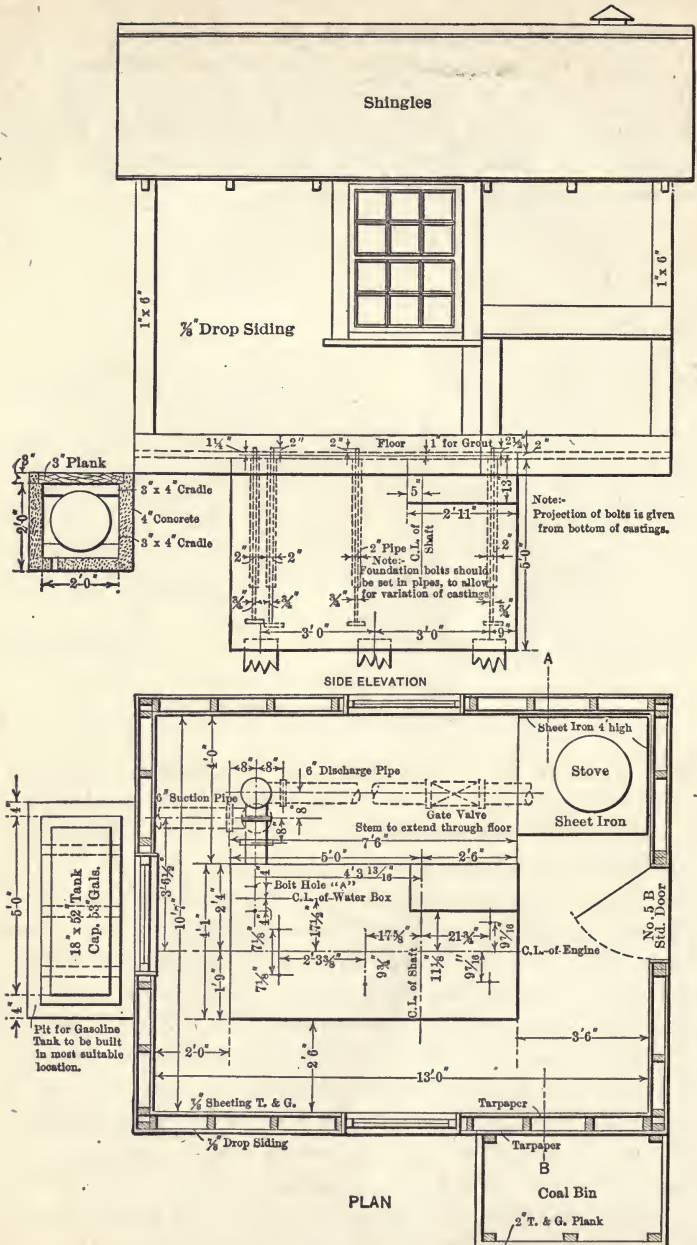

Fig. 217. C. L. O. & W. Ry. Pump House.

paper between. The cost of this type of house, without the pumping outfit, but including the foundation for the pump and the gasoline concrete pit, is about \$500.

**Dams.** — Dams for impounding water for gravity service average from 6 to 12 ft. in height, consisting usually of an earth embankment or such material as can be had conveniently near the location, or wood crib, or stone or concrete retaining wall.

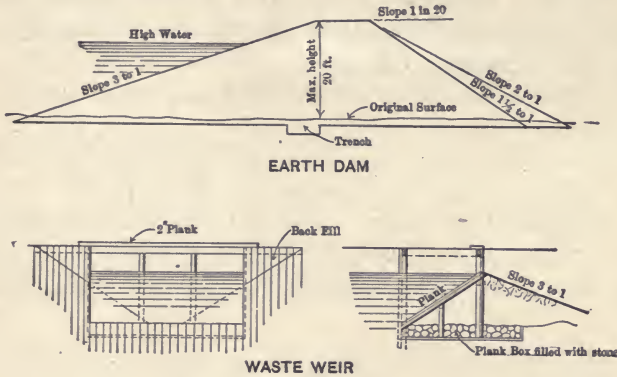

Fig. 218.

Fig. 218 represents the general cross section for earth dam; with ordinary material it is recommended that the upstream slope should not be steeper than 1 to 3, the rear slope  $1\frac{1}{2}$  to 1, preferably 1 to 1, top width not less than 6 ft. for a height of 10 ft. or less, 8 ft. wide from 10 to 15 ft. high, and 10 ft. wide for 15 to 20 ft. high.

The foundation should be on firm ground, with all sod and perishable matter removed over the entire area of the foundation for a depth of at least 6 inches, to prevent disintegration and possible leakage.

When the height exceeds 10 ft., an intercepting or bond trench 2 ft. deep, from 6 to 12 ft. wide, should be made running the full length.

The inner slope should be protected with a thick layer of hard material, and when subject to wave action a further layer of heavy rock should be provided; the rear slope is best protected by sod.

The waste way if possible should be located at a natural gap.

If placed close to the dam, care must be taken to prevent the spill from endangering the dam from washing, saturation, or erosion, by building aprons and wings to prevent the water from passing around or under the dam. For safety, waste water should always be discharged at a distance from the dam.

Top of levee should be at least 6 ft. wide and level with top of dam, with slopes or waste side not steeper than 1 to 3, riprapped when possible. Difference in elevation between top of dam and bottom of waste way should not be less than 4 feet, with slope of dam side at angle of repose.

A deep fall waste should have checks so as to form a series of smaller falls.

The waste way may be constructed of timber as shown in sketch, though permanent material is more desirable.

**Crib and Masonry Dams.** — When the location is convenient and only a gap or small length of dam is necessary a masonry or concrete wall or crib as illustrated in Figs. 219 and 220 is often used.

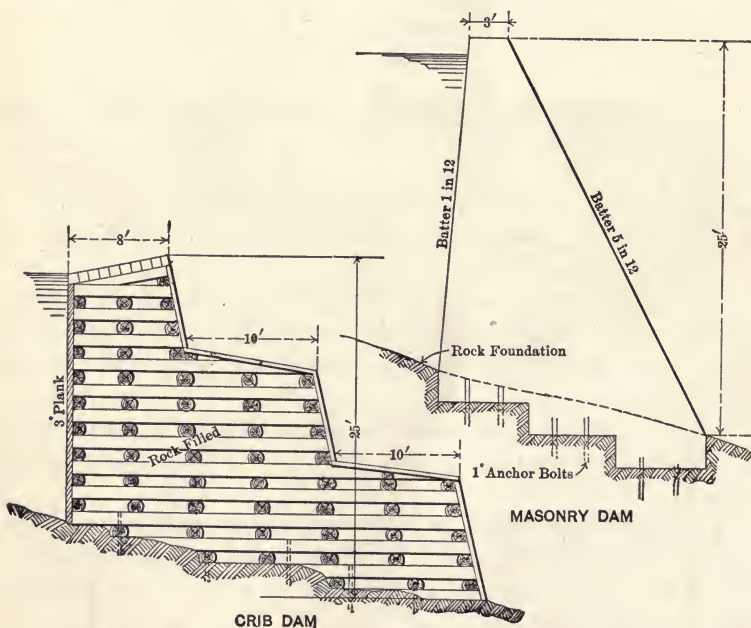

Fig. 219.

Fig. 220.

With the masonry dam it would be necessary to have a waste way at some natural point around the storage reservoir or a sluice with gate valves to let out the over surplus water in time of floods or severe storms.

The crib dam is built with three offsets so as to form a spill way in itself.

The approximate cost of dams will vary greatly, depending upon local conditions.

*Approximate Cost.* — Earth dams 12 ft. high, per lineal foot, \$5 to \$15. Wood and crib 25 ft. high, per lineal foot, \$40 to \$60. Stone dam 25 ft. high, per lineal foot, \$80 to \$150.

APPROXIMATE ESTIMATE GRAVITY WATER SUPPLY PIPE LINE 2500 FEET LONG (300 FEET IN DOUBLE WOOD BOX).

Crib dam:

3000 lineal feet cedar logs at 15¢ . . . . .	\$450.00	
6000 feet board measure timber at \$50. . . . .	300.00	
200 cubic yards boulder fill at 50¢ . . . . .	100.00	
Waste channel and fixing up gully for overflow. . . . .	150.00	
		\$1000.00

Pipe line:

1800 cubic yards excavation boulders and rock, \$2.00. . . . .	\$3600.00	
1500 cubic yards earth, 75¢ . . . . .	1125.00	
25 tons C. I. 4-inch pipe, \$35.00. . . . .	875.00	
16 tons W. I. pipe, \$38.00. . . . .	61.00	
1500 pounds lead for joints, 8¢ . . . . .	120.00	
Hauling and distributing pipes. . . . .	125.00	
Laying joints. . . . .	125.00	
Valves, bends, etc. . . . .	100.00	
		\$6131.00

Boxing pipe account of precipice 300 feet:

10,600 feet board measure timber, per thousand \$50.00 . . . . .	\$530.00	
4200 square feet tar paper, 10¢ . . . . .	42.00	
Trestle support to pipe when boxed. . . . .	100.00	
		\$ 672.00

		\$7823.00
Supervision and contingencies. . . . .		777.00
		\$8600.00
Total. . . . .		

## CHAPTER XIX.

## FUEL STATIONS.

Coaling stations are erected to supply engines quickly with coal, to reduce delay to engines and to release coal cars as soon as possible, to take care of all coal held for emergencies (at least three days' supply), and to minimize the cost of handling.

They are usually built at divisional, terminal, and other points and are principally constructed of wood, though concrete and steel are coming into extensive use for this class of structure. Generally speaking, no mechanical plant can handle coal, ashes, and sand with the same mechanism and do it efficiently; the nature of the materials is such as to render this a very difficult matter.

The structure is usually located parallel to or across the round-house tracks, convenient to the cinder pits, the arrangement depending upon the type of coaling plant adopted.

In figuring the cost of handling coal the unit considered is generally one ton of 2000 pounds.

To make a fair comparison for any type the following items should be estimated and fair values given to each.

*Capacity of Plant.*

Interest on first cost. . . . . 6 per cent.

Depreciation. . . . . 10 per cent to 20 per cent.

Operation.

Maintenance.

Car storage.

Switching charges.

*Capacity of Plant.* — In addition to the tons of coal handled per day, the storage capacity of the plant should be considered.

*Car Storage.* — Car storage is usually much more expensive than storing in bins. Figuring a car holds 40 tons, and that it is worth a dollar a day, storage in cars costs  $2\frac{1}{2}$  cents per ton per day.

Self-clearing cars can be unloaded into a hopper at from 5 to 6 cents less per ton than from flat-bottom cars by hand.



*Switching.* — When coal is delivered in self-clearing cars and dumped into a hopper, tracks can be arranged so that cars can be handled by gravity, without the need of a switcher, thereby reducing the cost of operation.

There are a number of methods in vogue for the handling of coal for locomotive purposes; in general, however, it may be said, — at least at terminals and busy points where a large number of engines are handled, — that two methods predominate, either the elevated trestle type of coaling plant with trestle approach is used, or the mechanical type of plant where the coal is handled by machinery and carried to elevated pockets is adopted.

The chute known as the “White” type is very common, especially on western roads. The general construction of this chute is shown on Fig. 221. The chutes may be on one or both sides of the shed, depending upon local conditions.

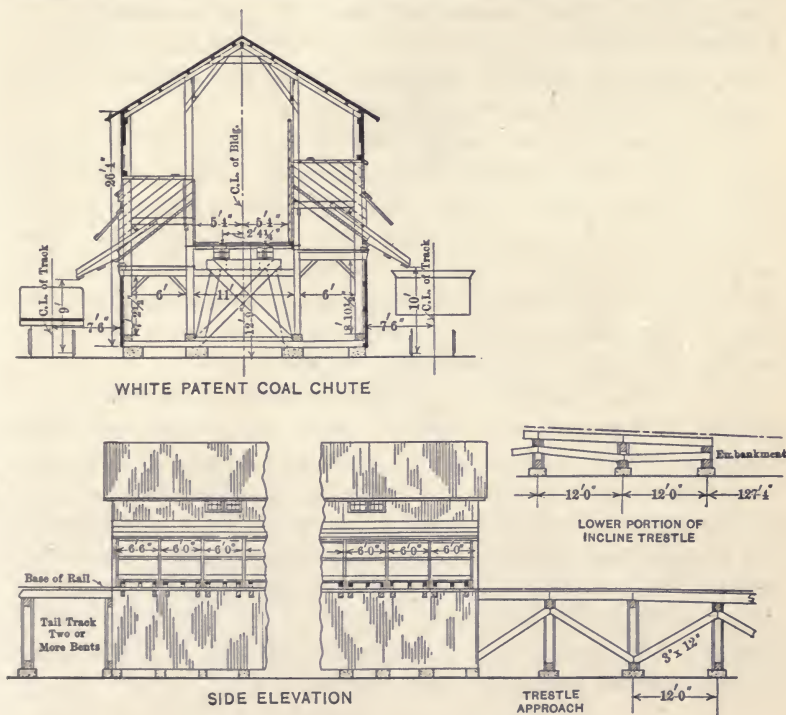

Fig. 221. White Type Coaling Chutes.

In most cases cars of coal are delivered to the plant by means of an incline and a locomotive. In some instances, however, a short, steep incline is constructed and the cars are hauled up by means of a stationary engine and cable. The coal is then shoveled into the chutes. When a locomotive takes coal the fireman or hostler opens the chute by means of a chain.

As a general rule, in coaling stations of this character a regular force of coal heavers is employed, the number of men, of course, depending upon the quantity of coal handled.

*Approximate Cost.*—Figuring a six pocket chute and three-pile bent incline approach 500 ft. long, under normal conditions will cost from \$5500 to \$7500.

During the past few years the mechanical type of coaling plant has been most in evidence and, in general, is being used in preference to the trestle type.

It may be set down as a general principle that a mechanical coaling plant is very economical when the full capacity of the machine is utilized. On the other hand, where the quantity of coal handled is small in comparison with the capacity of the machine, it will not make a good showing.

The trestle type of coaling plant takes up a lot of ground space and usually cannot serve more than two tracks, and while a great number of chutes can be installed, any line may be blocked by the first engine taking coal. There is also the objection to the locomotive climbing a steep grade to get the coal to the elevated pockets and the large maintenance cost of a structure of this character after it has been in service a few years, and there is always the fire risk to be considered.

On the other hand, the mechanical coaling plant takes up a minimum of ground space and can serve any number of tracks; if the machinery is of the proper quality and properly cared for, very few, if any, breakdowns need occur. The structure can be made of fire-proof material, if desired, and the arrangement can be such that the labor charges will be very low. The power required to run a mechanical plant is comparatively small, and if the machinery is well designed and of the very best quality and the full capacity of the machine utilized, it will handle coal at less cost than any other method.

**Elevated Chutes (Trestle Type).** (Figs. 222 and 223.)— For flat-bottom car service where the coal is shoveled by hand into elevated bins, the trestle requires to be at least 25 ft. above the engine track.

If the cars are pushed up the trestle by a switching engine, the grade should not be more than 5 per cent; if by stationary hoisting engine, this can be increased to 20 per cent.

For the trestle type of coaling station the hoisting engine is considered the best way to elevate the coal. The switching of

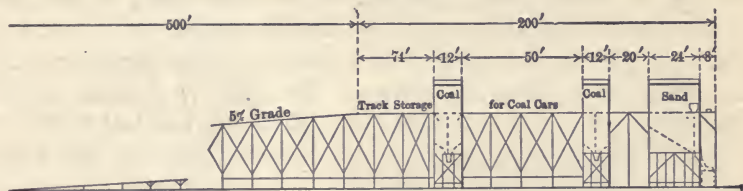

Fig. 222.

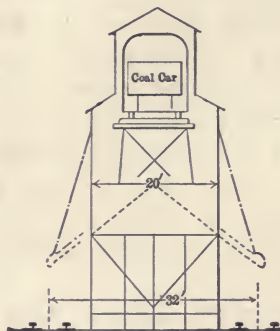

Fig. 223.

the cars on the trestle by ordinary locomotives is considered dangerous and expensive.

This plant consists of a wood trestle 5 per cent grade, with two 100-ton pockets and sand bin located between tracks.

The approximate cost complete is from \$15,000 to \$18,000.

The coal chute is of timber construction throughout with a track reaching the upper deck by means of a framed approach trestle. In this case the locomotive pushes the coal cars up the incline where they are spotted over the coal chutes.

**Coaling Station with Locomotive Hoist.** — A design borrowed from the Baltimore & Ohio R.R. in which the pockets rest normally at ground level while being filled and are then hoisted by locomotive power to an elevation suitable for loading the tender by gravity flow, Fig. 224. The design is very simple, consisting of an upright framework of 12" × 12" timbers, to serve as guides for the pocket, with a hoisting sheave at the top and another at the bottom. The movable pocket has the usual inclined bottom, and its top is at a convenient height for unloading by hand from a gondola car on side-track, at the rear of the structure. The capacity of each pocket is six tons of coal. At the front side there is a gate and drop apron or chute for admitting coal to the tenders. The gate is of such pattern that the quantity of coal taken on can be regulated at will.

The locomotive to be coaled does its own hoisting, the hoisting cable being of such length that, when the loop at the end thereof is hooked over the pilot beam, the pocket will be hoisted to the desired height by the time the locomotive has pulled ahead far enough to bring the tender opposite the pocket. The pocket being emptied, the locomotive backs up and lets it down again. In the station referred to there are duplicate pockets, one for loading in either direction.

Figure 224 shows the framing, general plan and the details of the hoisting pocket. The pocket is merely a strong box securely held with bolts at the four corners, with a piece of 100-lb. rail caught under the top timbers of the pocket, to which the hoisting cable is attached.

Its use is applicable only to isolated places where conditions are suitable. The plant complete will cost in the neighborhood of \$1000 and has to be handled very carefully in operation. A coaling device of this kind requires constant attention and the cost of maintenance will usually be high.



**Mechanical Plants.** — The ordinary mechanical plants, consisting of elevated pockets fed by endless chain, belt, or buckets, are arranged to hold from 30 to 800 tons or more, the amount of coal elevated per day depending upon the capacity required, the number of tracks to be served, and the storage necessary for emergencies.

The cost of a mechanical type of coaling plant varies according to capacity and style of plant adopted, and may range from \$20 to \$75 per ton capacity. In cases where it is necessary to weigh the coal taken by locomotives the cost is somewhat increased.

*Two-pocket Plant, Single Track, Wood Structure.* — Fig. 225 illustrates a two-pocket single-track McHenry coaling plant with dynamometer weighing device to each pocket so that the amount of coal taken by each tender can be recorded. Capacity 70 tons. Cost complete \$4000 to \$5500.

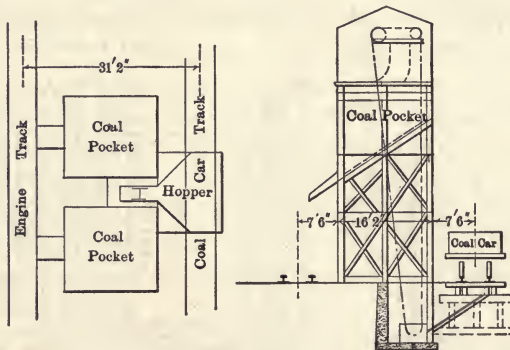

Fig. 225.

*Four-pocket Plant, Single Track, Wood Structure.* — Fig. 226 illustrates a four-pocket, single-track McHenry coaling plant with weighing device to each pocket. Capacity 140 tons. Cost complete \$8000 to \$9500.

In the two and four pocket plants the coal car is spotted over the hopper and dumped, the coal running by gravity into the boot, where it is hoisted by endless chain and bucket method to the pockets above. On the upper horizontal run the coal is scraped along the conveyor. Gates are provided to each pocket

so that the coal may be dumped into any one desired by leaving the gate open. In the four-pocket plant the chains and buckets make an entire circuit round the house, the drive being set above the up-shaft end. The engine house with steam or gasoline

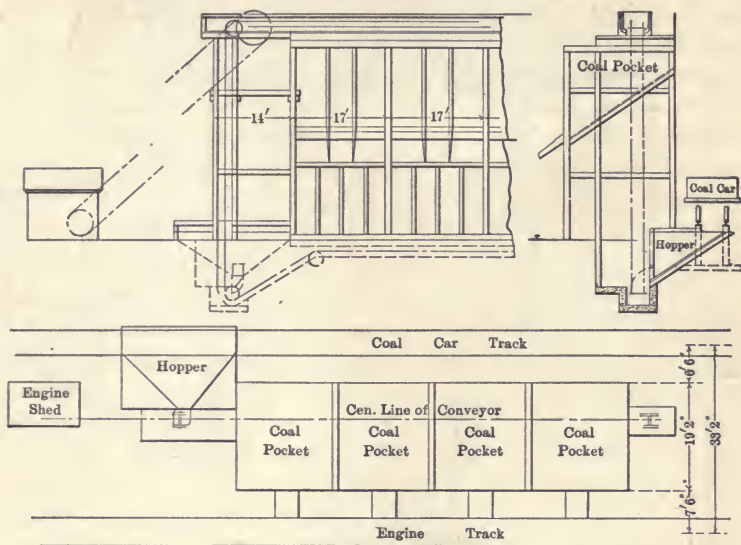

Fig. 226.

power is placed a little beyond the coal structure, and a rope drive connects the engine with the main drive above. If desired, the mechanism can be motor driven direct or by pulley, thus dispensing with the engine house, when electric power can be obtained. The chain speed is 65 ft. per minute and the power consumption about 12 to 15 horsepower. The space under the pockets may be boarded and used for storage purposes.

*Four-Pocket, Three-track Plant, Wood Structure.* — Fig. 227 illustrates a four-pocket, 150-ton elevated capacity, three-track coaling plant. Cost complete \$12,000 to \$16,000 with dynamometer weighing device to each pocket, so that the amount of coal taken by each tender is recorded. Under the elevated pockets next to the coal hopper the space is boarded and used for storage purposes if desired, gates being provided so that the coal can flow back into the hopper and be re-elevated when necessary.

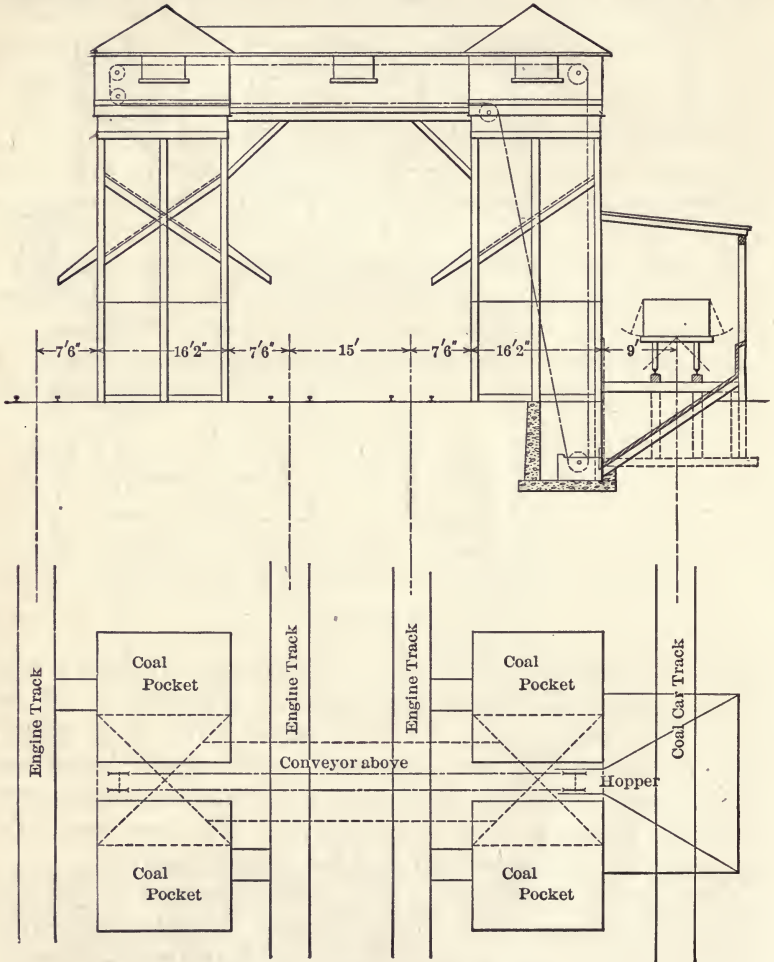

Fig. 227. Three-track coaling plant.



This structure is a modification of the McHenry type of coaling plant, and consists of two double elevated coal pockets, located between three tracks and connected together on top by a house spanning two tracks; the bottom hopper, into which the coal is dumped, is located behind the main pocket on one side, and is elevated 6 ft. 6 in. above the locomotive service track, and made wide enough to take side-dump as well as center-dump cars.

The elevating mechanism consists of endless chain and buckets and a steel boot. From the bottom of the hopper the chain is carried up and over the house across the tracks, returning under the floor, and back to the boot. The drive is run by electric motor controlled by a switch on the ground near the coal dump hopper for the convenient use of the operator.

When the coal is dumped into the hopper it flows by gravity into the boot, regulated by a gate, and is picked up by the endless buckets and hoisted up to the elevated pockets above and along the horizontal trough over the track. Openings with slide doors and chutes are arranged to supply any pocket with coal when desired. The chain speed is 65 ft. per minute and the power consumption about 20 horsepower.

**Sand Tower.** — With the foregoing arrangement three tracks are provided for coaling locomotives, and the space between the elevated pockets facing the track may be used as a sand tower, so arranged that sand can be furnished on two tracks, the sand being elevated by air pressure from a cylinder in the drying room through inclined pipes, the sand house being located between the two tracks about 50 ft. ahead of the structure. The cost of the wood sand house lined with galvanized iron on the outside, including sand bins between coal pockets and all mechanism, averages from \$1200 to \$1500.

A number of mechanical plants built on the C. P. R. and their approximate cost are given on page 482 as follows:

Single Track Plant, Capacity 76 Tons — \$12,000 to \$13,000

Two Track Plant, Capacity 200 Tons — 15,000 to 16,000

Three Track Plant, Capacity 300 Tons — 18,000 to 20,000

General Layout.

Capacity and Cost of a Number of Mechanical Plants.

	<p>Single Track</p>	<table border="1"> <tr><td>Coaling Plant</td><td>\$ 8,500</td></tr> <tr><td>Approach</td><td>2,000</td></tr> <tr><td>Sand House</td><td>10,500</td></tr> <tr><td></td><td>1,500</td></tr> <tr><td></td><td>12,000</td></tr> <tr><td>If Gasoline Engine req'd add</td><td>1,500</td></tr> <tr><td>Total</td><td>\$13,500</td></tr> </table>	Coaling Plant	\$ 8,500	Approach	2,000	Sand House	10,500		1,500		12,000	If Gasoline Engine req'd add	1,500	Total	\$13,500
Coaling Plant	\$ 8,500															
Approach	2,000															
Sand House	10,500															
	1,500															
	12,000															
If Gasoline Engine req'd add	1,500															
Total	\$13,500															
	<p>Two Track</p>	<table border="1"> <tr><td>Coaling Plant</td><td>\$11,200</td></tr> <tr><td>Approach</td><td>2,000</td></tr> <tr><td>Sand House</td><td>13,200</td></tr> <tr><td></td><td>1,800</td></tr> <tr><td></td><td>15,000</td></tr> <tr><td>If Gasoline Engine req'd add</td><td>1,500</td></tr> <tr><td>Total</td><td>\$16,500</td></tr> </table>	Coaling Plant	\$11,200	Approach	2,000	Sand House	13,200		1,800		15,000	If Gasoline Engine req'd add	1,500	Total	\$16,500
Coaling Plant	\$11,200															
Approach	2,000															
Sand House	13,200															
	1,800															
	15,000															
If Gasoline Engine req'd add	1,500															
Total	\$16,500															
	<p>Three Track</p>	<table border="1"> <tr><td>Coaling Plant</td><td>\$ 14,500</td></tr> <tr><td>Approach</td><td>2,000</td></tr> <tr><td>Sand House</td><td>16,500</td></tr> <tr><td></td><td>2,000</td></tr> <tr><td></td><td>18,500</td></tr> <tr><td>If Gasoline Engine req'd add</td><td>1,500</td></tr> <tr><td>Total</td><td>\$20,000</td></tr> </table>	Coaling Plant	\$ 14,500	Approach	2,000	Sand House	16,500		2,000		18,500	If Gasoline Engine req'd add	1,500	Total	\$20,000
Coaling Plant	\$ 14,500															
Approach	2,000															
Sand House	16,500															
	2,000															
	18,500															
If Gasoline Engine req'd add	1,500															
Total	\$20,000															

**Locomotive Crane.** (Fig. 228.) — With the locomotive crane the coal is taken direct from flat-bottom cars by grab buckets and hoisted into the tender. When self-clearing cars are used, a pit is constructed and the coal dumped, from which it is handled by the crane.

To avoid delays to locomotives elevated pockets are sometimes built and the coal hoisted by a long boom crane. With

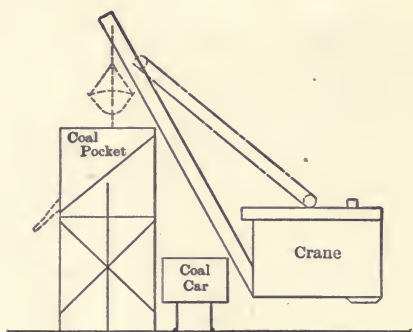

Fig. 228.

proper structural facilities the crane can also handle cinders, and in some cases the sand, and is available at odd times for switching cars.

The cost of the locomotive crane set up complete depends on its capacity and may vary from \$7000 to \$9500 or more. The cost of storage pit and elevated pockets when desired is also a very variable quantity. In addition a certain amount of special track and yard room has to be figured.

A one-ton bucket and 42-ft. boom crane with a 50-ton elevated pocket, including the extra track arrangement, would average \$9500.

The cost of handling coal by crane depends upon the scheme of coaling facilities and the work it can do in handling ashes, etc., at odd times.

**Belt Conveyor.** (Fig. 229.) — This plant may consist of one or a series of pockets with an inclined belt on a 25-degree slope, fed from a track hopper beneath the coal car track, the coal being delivered to the belt by automatic feeders.

A 30-in. wide belt, 180 ft. run, with a speed of 100 ft. per minute will deliver 50 tons per hour.

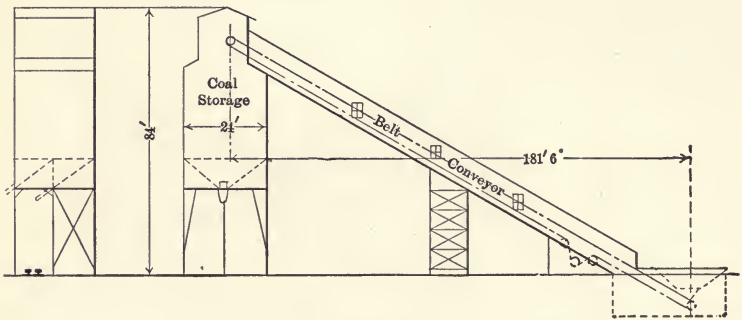

Fig. 229.

The belt and its supports with a gang walk is usually housed in and supported by trestle, under which the engine room is placed.

The coal pockets are wood construction usually, and a sand shed beneath the coal wharf can be arranged and the sand shot by air to a storage tank at the top of the bin, from which it is piped to the engines as required.

The approximate cost of a wooden structure, single pocket, 500 tons capacity plant, including sand house, etc., complete, averages from \$12,000 to \$18,000.

**Balanced Bucket or Holman Type.** (Fig. 230.) — The elevated pocket has a capacity of 350 tons. The coal car is spotted over the hopper and fed by gravity into two vertical cars that are alternately hoisted and lowered, one going up as the other comes down. The buckets are automatically fed and dumped by feed device and tripping arrangements, the buckets being designed to hold three tons and are self-clearing.

They are operated by hoist with cable drive and 25-horsepower motor controlled by the operator in the engine room. At a speed of 60 ft. per minute 100 tons can be delivered to the elevated pocket per hour.

The approximate cost of the plant complete averages from \$12,000 to \$15,000.

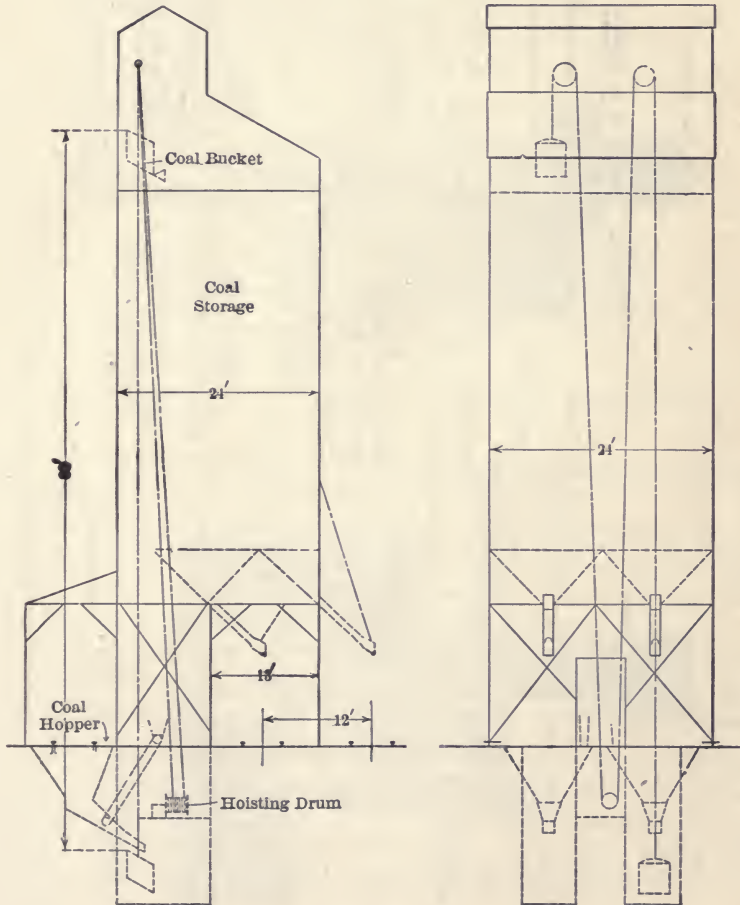

Fig. 230.

100-ton Mechanical Coaling Plant, C. N. R. (Fig. 231.)— The coal is carried in an elevated coal pocket, 14 by 22 ft., of a depth varying from about 10 to 20 ft., the bottom having a slope with regard to the horizontal of about 30 degrees. This pocket is carried on 8 heavy squared timbers, resting on concrete piers, heavily cross braced. The coal pocket, supported

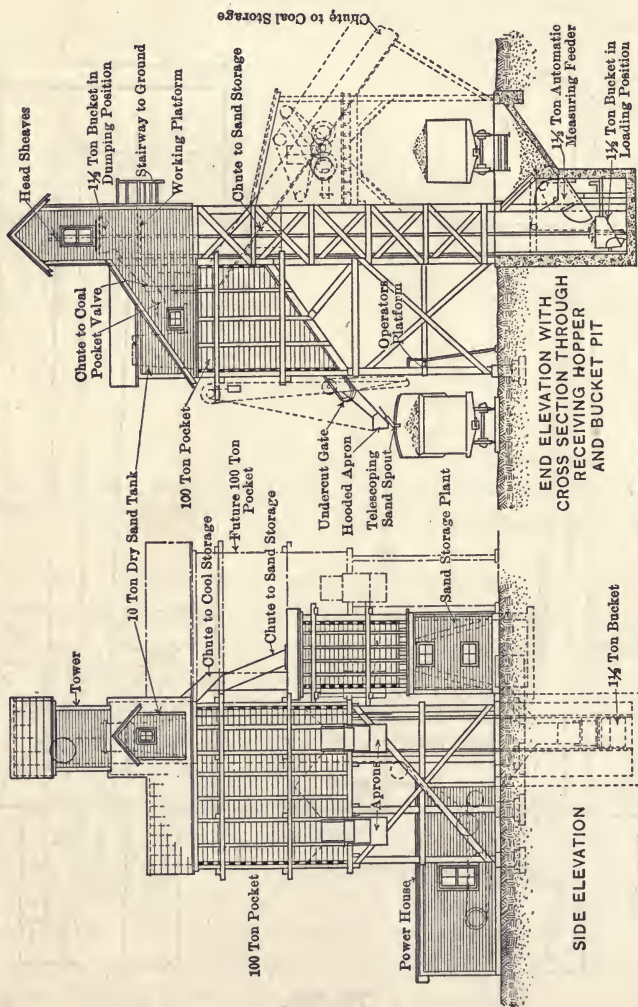

Fig. 231. 100-ton Mechanical Coaling Plant, C. N. R.

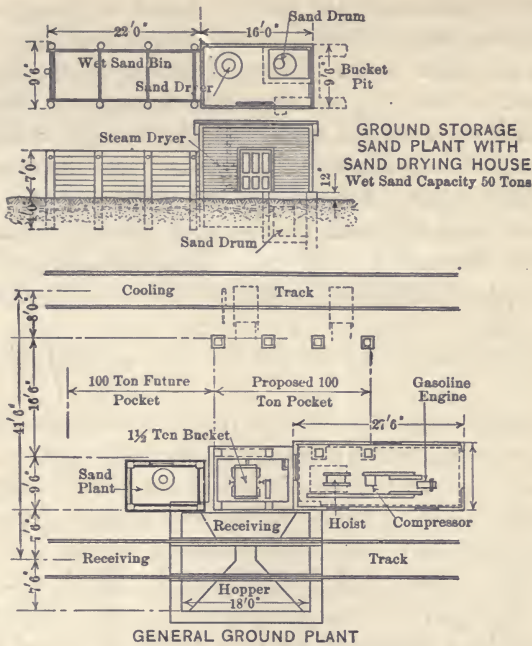

Fig. 231 (Continued). 100-ton Mechanical Coaling Plant, C. N. R.

by, and contained between, these columns, is composed of heavy planking.

The elevator shaft consists of four wooden columns, two of which are those of the coal pocket supports, the other two being carried on the concrete side walls of the receiving coal hopper. The elevator shaft extends into a pit, 18 ft. deep.

Back of the elevator is a receiving hopper, underneath the delivery track, which spans the pit on two tracks, supported by I beams. The hopper and elevator pit are concrete lined, the receiving hopper having sloping sides. The coal is delivered on cars and run over the hopper and dumped. The area of the receiving hopper is 11 by 14 ft., and it slopes in three directions. The feeding mechanism consists of a gate, chute and feeder, the latter delivering the coal automatically in  $1\frac{1}{2}$  ton lots.

The elevating bucket is  $1\frac{1}{2}$  ton capacity, and 4 ft. square.

The apron or folding chute is kept closed in its upward travel by a roller on its front face bearing against a guide. The elevator ways are 30-lb. rails. The movement of the bucket from the bottom of the pit, automatically causes the feeder to revolve, filling up with the measured  $1\frac{1}{2}$  ton. At the top of the elevator travel, the apron roller guide bends forward and the apron swings open, discharging the coal through the apron to a chute, into the coal pocket. As the bucket commences to descend, the apron is closed. On approaching the bottom of the pit, the feeding mechanism is automatically operated and fills the bucket.

The approximate cost would be about \$9500 without sand house.

The sand storage is a small frame building adjoining the hoistway, of similar construction to the coal pocket. A chute, leading into it from the top, is fed in exactly the same manner as the coal pocket, a valve in the coal pocket chute diverting the sand as elevated from the receiving hopper into the sand pocket chute. Beneath the sand pocket there is a sand drying room, fed by gravity from the supply above. The dried sand is delivered by compressed air to a 10-ton dry sand tank, situated directly over top of the coal pocket. There is also a 50-ton ground storage plant for wet sand.

The coaling plant is designed so that a 100-ton pocket can be added in the future. The total capacity would then be 200 tons, somewhat large for a single-track plant. The construction throughout is principally wood, excepting the portion of the pit and coal hopper, which are built of steel and concrete. The inside of the pockets are lined with sheet iron to facilitate the flow of coal.



**260-ton Coaling Station, N. & W. Ry.** (Fig. 232.) — The building is entirely of reinforced concrete and provides overhead storage facility for 260 tons of coal and 10 tons of dry sand, ground-floor storage for 100 tons of wet sand. The general arrangement provides for supplying both coal and sand to engines on three tracks — two main tracks which the station spans and one outside track which also is used for dumping coal into the track hopper and shoveling sand into the wet storage bins.

Each of the three service-tracks is supplied with coal through a coaling chute, the flow being controlled by a gear-operated undercut gate. Sand is delivered through special swiveled, telescopic spouts that can be adjusted to suit the position of the locomotive; one of these spouts serves the two inside tracks and another the outside. All chutes and spouts are counter-balanced and, when not in use, are swung up and out of the way automatically.

The track hopper for receiving coal from the cars is 10 ft. wide by 12 ft. long and is fitted, as shown in Fig. 232, with a reciprocating apron which feeds the coal to an elevator of the gravity-discharge type. The elevator consists of V-shaped steel buckets 36 in. long by 22 in. wide by 10 in. deep attached every 3 ft. between two strands of steel link chain fitted with 4-in. rollers chamfered to admit of lubrication. It has a vertical travel of 60 ft. from the hopper to the top of the pocket and then a horizontal run of 33 ft. over the bin into which it discharges through two two-way chutes. The horizontal run has a speed of 50 ft. per minute and a capacity of 50 tons per hour.

The objection to a concrete structure for coaling plants is due to the fact that most yards are susceptible to change and enlargement and it is an exceedingly difficult matter to wreck a building of this character. There is little or no salvage and the cost of demolishing it is very high.

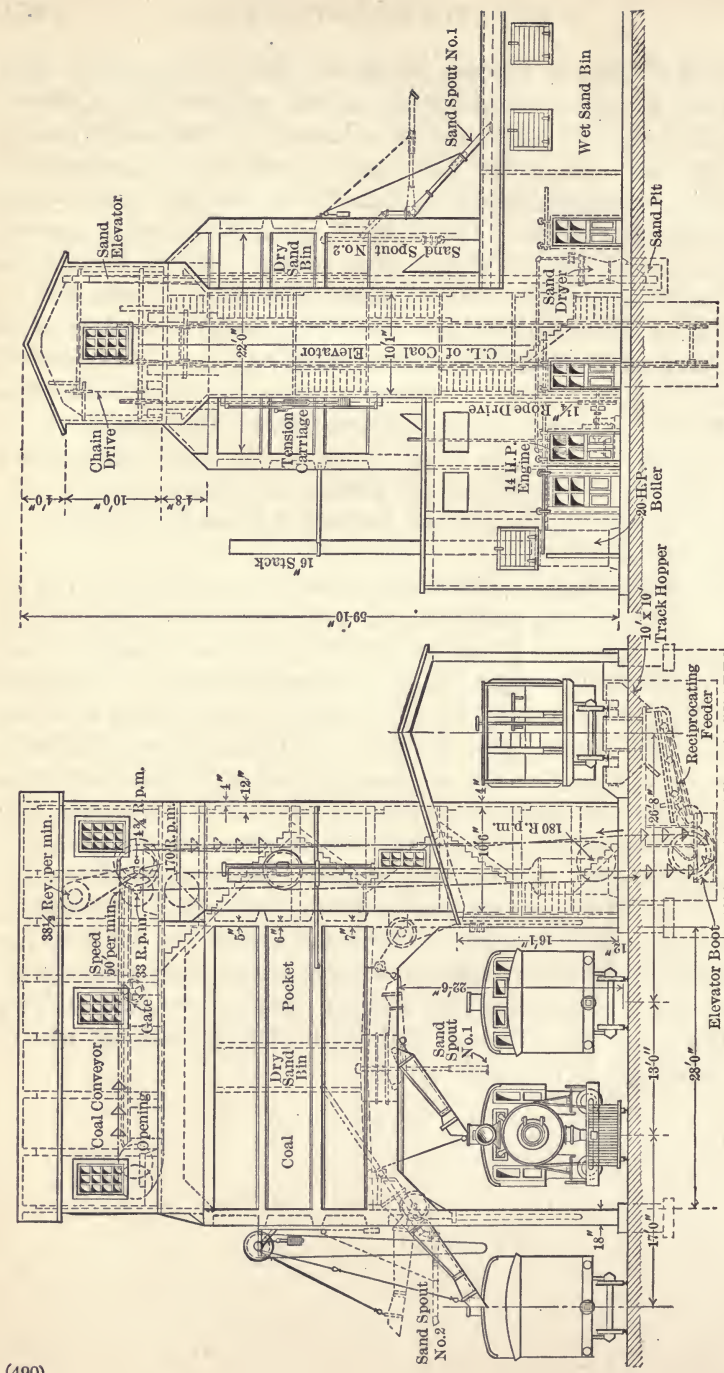

Fig. 232. 260-ton Coaling Station, Norfolk and Western Ry.

### Sand Houses.

At divisional and other points where engines are housed, provision is usually made to supply locomotives with sand to use in case of slipping on heavy grades or on account of climatic conditions. This generally consists of a small wooden house with an extension wet sand storage bin and an elevated dry sand box or tower, into which the sand is elevated by manual labor or some mechanical hoisting device or by blowing it through a pipe by compressed air, where it is stored and run by gravity to the sand box of the locomotive when required. The shed is generally arranged so that the wet sand can be conveniently delivered and shoveled from cars to the storage bin, the bin being sufficient to hold at least one carload. A small room is provided to house in the sand drier and hoisting mechanism, etc.

Instead of hoisting the sand into elevated hoppers, a platform is often used on which dry sand is placed in buckets arranged so that they can be easily handled by the enginemen, the platform being placed alongside the engine track on a level with the foot-board of engines.

The sand is dried by cast or sheet-iron drying stoves, or by steam pipe troughs, and is generally screened before being placed for use.

The sand house is usually located in close proximity to the coal and water supply, so that engines when taking coal or water can at the same time obtain their supply of sand.

*Approximate Cost.* (Fig. 233.) — 32 ft. long, 13 ft. wide, consisting of wet sand bin 16'  $\times$  12', drying room 14'  $\times$  12', small coal bin, sand drier and screen, compressed air cylinder and elevated sand tower, masonry foundation, \$700 to \$900. With wood foundation, balance as above, \$600 to \$700.

*Construction.* — Wood sills or masonry foundation, concrete floor in sand-drying house, frame walls, 2-in. plank on 4"  $\times$  4" studs at 4-ft. centers, lined on the outside with corrugated iron; no finish inside; roof, 3-in. plank with 6"  $\times$  8" beam, tar and gravel finish; tower, 8"  $\times$  8" posts well anchored to base at floor level, height about 30 ft. from base of rail to center of sand storage, braced with 2"  $\times$  6" horizontal and cross timbers; sand tower walls 2-in. plank with corner posts, roofed over with

$\frac{7}{8}$ -in. T. & G. boards, covered with shingles and building paper between boards. The tower is provided with sand valve and spout with rubber hose at end for running the sand to the engines.

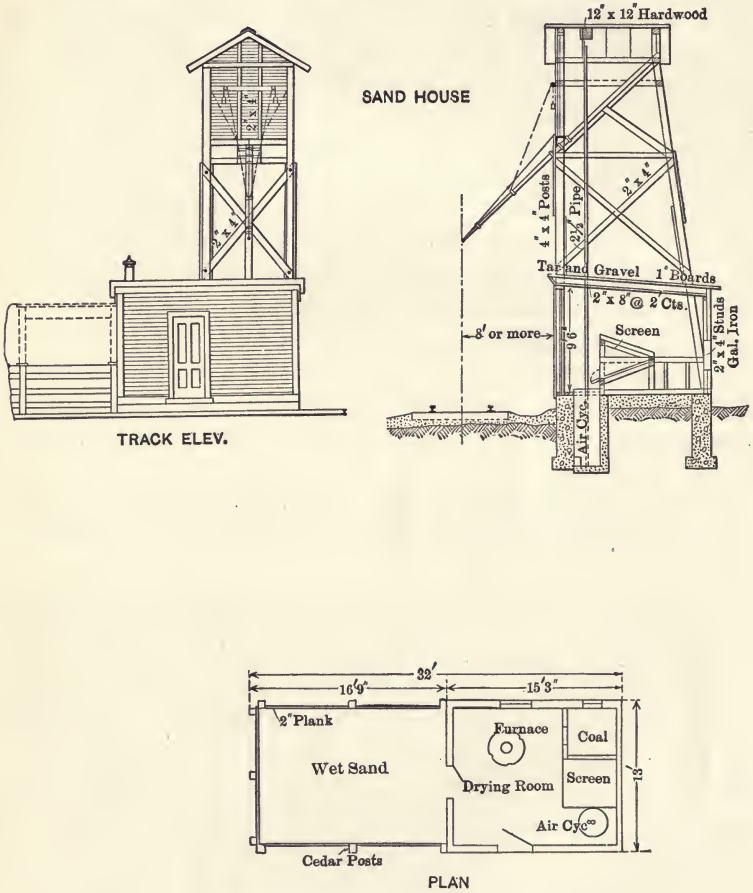

Fig. 233. C. P. R. Sand House.

*Wet Sand Storage.*—Two-inch plank walls supported by 8" × 8" posts about 8-ft. centers, set on cedar sills on the ground, or the posts may extend into the ground 5 ft. or thereabout; roofing 2-in. plank and 8" × 8" rafters, with tar and gravel finish. The length of wet sand bin varies to suit conditions.

APPROXIMATE ESTIMATE OF COST. FIG. 233.

Quantities.	Material.	Labor.	Total unit.	Cost.
40 cubic yards excavation.....			\$ 0.50	\$ 20.00
24 cubic yards concrete.....	\$ 3.50	\$ 3.50	7.00	168.00
8 cubic yards sand fill.....			0.50	4.00
8000 ft B. M. lumber, per thousand.....	18.00	17.00	35.00	280.00
2 doors.....	5.00	2.50	7.50	15.00
1 window.....	6.00	3.00	9.00	9.00
1 sand-drying furnace with cast-iron smoke jack and piping.....	20.00	23.00	....	43.00
1 compressed air sand cylinder.....	25.00	30.00	....	55.00
30 feet 2½-inch pipe.....	0.16	0.17	0.33	10.00
1 glove valve.....	1.75	0.50	....	2.25
1 drain cock.....	0.75	0.25	....	1.00
5 squares galvanized or corrugated iron, per square.....	4.00	3.00	7.00	35.00
Sand screen.....	2.00	0.50	....	2.50
1 sway supply spout with connections.....	20.00	9.25	....	29.25
1½ squares shingles, per square (100 square feet).....	2.00	2.00	4.00	6.00
4 squares tar and gravel roof, per square (100 square feet).....	2.50	2.50	5.00	20.00
Painting.....	14.00	16.00	....	30.00
Concrete floor.....	8.00	12.00	....	20.00
				\$750.00
If wood foundation is used under sand-drying room, deduct.....				150.00
				\$600.00

The sand air cylinder is embedded in concrete below the floor level, the sand running by gravity from the screen to the cylinder. The refuse from the screen falls into a wooden bin on the opposite side and is removed by shovelling when desired.

**Sand Storage.** — The sand storage bin shown on Fig. 234 as built by the Chicago and Alton at Glen, Ill., is located at one end and is a part of the coal chutes with the track above, consisting of three bins with a capacity of 374 tons of wet sand each, and one double dry sand bin with a capacity of 66 tons. The wet sand bins extend down considerably below the level of the coal chute bin floor to a dryer, provided in the bottom of each bin. The dry sand is elevated by compressed air into a dry sand storage.

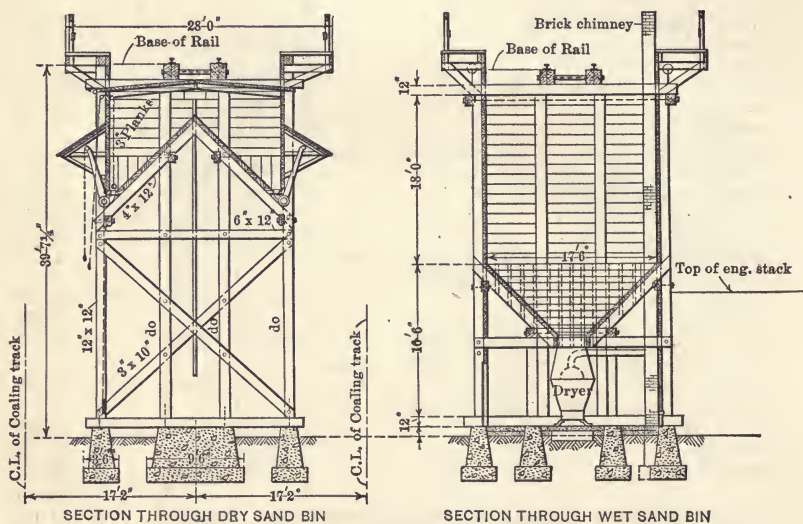

Fig. 234. Sections Through Sand Bins, C. & A.

The structure is built almost entirely of wood excepting the foundations which are of concrete. The objection to this type of structure is the fire risk on account of having the dryer immediately under the structure. With a steam dryer, however, the risk could be eliminated.



The turntable should be from 500 to 600 ft. at least from the coal chutes to allow for engines standing after taking coal.

The typical layout suggested by the A. R. E. Assoc., Fig. 235, cover the features involved, which will necessarily be modified to suit the location, the shape and size of ground site, etc., where such are fixed.

A modified layout of a terminal in a congested area is shown, Fig. 236, which illustrates the track and facilities provided at Decatur, Ill., on the Wabash, where approximately one hundred engines are handled per day.

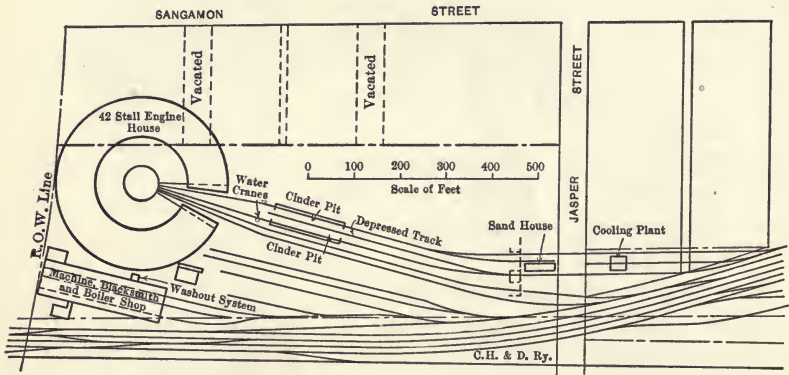

Fig. 236. Layout Engine Terminal, Decatur, Ill.

The Lake Shore and Michigan Southern Ry. terminal at Air Line Jct., Ohio, is shown, Fig. 237. The layout comprises two engine houses, a power house, machine and blacksmith shop, and other buildings conveniently grouped. The twenty-seven stall house is for freight engines and the thirteen-stall house for the mallet pusher locomotives. Both houses are provided with a 90-ft. turntable.





**Engine Houses.** — In the past few years there has been a great improvement in the design of engine houses, particularly in regard to light, heat, and ventilation. There has also been added facilities and equipment to further its efficiency, including the introduction of lockers and proper toilet arrangements either in the house itself or in the boiler and machine shop, which is usually an annex or extension to the engine house when it exceeds 10 stalls. Drop pits are also provided for driving wheels, engine and tender wheels when running repairs are required to any extent, with overhead cranes or trolleys for removing dome caps, front end doors, bumper beams, etc.

Washout systems for washing out and filling locomotive boilers have also been introduced to a very large extent for protection against leaky flues and economy in firing up, etc., with storage tanks for the conservation of the water blown from the boilers which is reused for washout purposes and refilling, the refilling water being filtered before being reused in the boilers.

A great number of engine house designs, varying mostly in cross-section, have been produced and some typical sections in general use are shown, Figs. 238 and 239.

The flat roof construction is probably the most common. It has the advantage of being simple in design, is easier to heat and is fairly low in first cost and economical in maintenance.

On account of the destructive nature of the smoke fumes there is a desire on the part of designers to eliminate almost entirely, when possible, any steel or exposed iron work of any kind in its construction and where timber is not used for the posts and beams, reinforced concrete has been generally adopted; where steel is used it is generally encased in concrete.

On the C. P. R. it has been found that the mill type all wood construction, excepting for outside, dividing or end walls, has proven more satisfactory than steel and concrete construction. There are a number of reasons for this; with concrete in very cold weather sweating may take place from the opening and closing of doors in the movements of engines, and, unless very well insulated, the roof is liable to drip at certain times by the chilling of exhaust steam on the cold concrete surface; the house is also harder to heat and is exceptionally high in first cost.

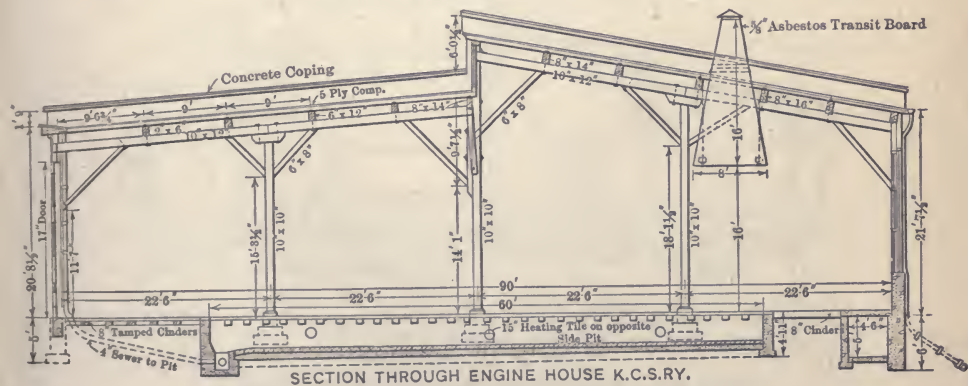
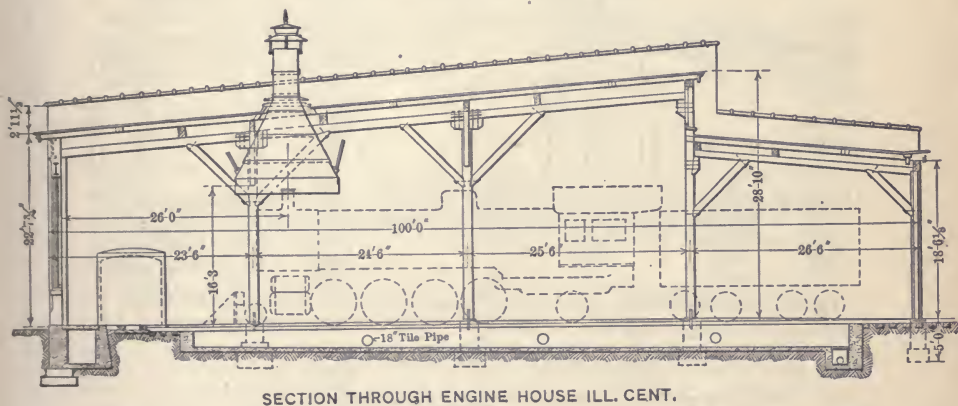
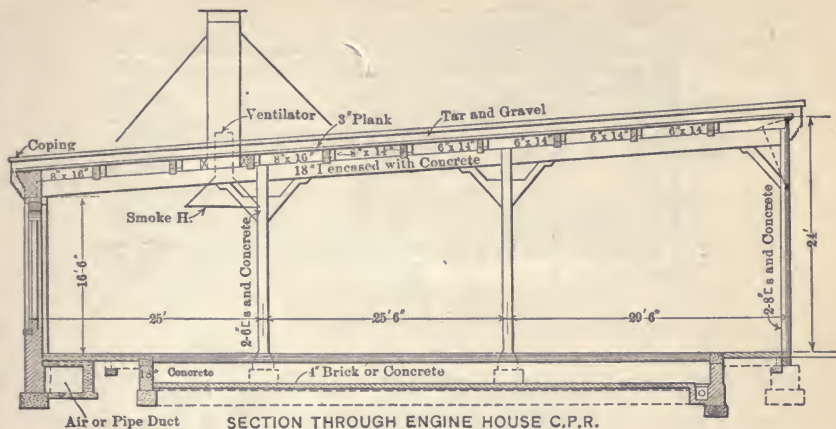

Fig. 238. Typical Cross Sections of Engine Houses.



In the mill type building where laminated construction is used on the roof and heavy wood beams for the roof timbers and posts these defects do not occur; a building of this sort is semi-fireproof, is very hard to burn, is fairly low in first cost, easy to maintain, and in the event of a change of location has some salvage.

A few typical cross sections of the various types of engine house are shown, Figs. 238 and 239, which give a fair idea of their general construction.

For the mill type the posts vary from 10"  $\times$  10" to 12"  $\times$  12" with 6"  $\times$  6" or 6"  $\times$  8" braces connecting the posts and the main run beams. The main beams vary from 10"  $\times$  12" to 10"  $\times$  16" depending upon the span. Roof beams 8"  $\times$  12" to 8"  $\times$  16" varying from 6 ft. to 8 ft. centers over which is built a solid timber roof with boards laid on edge and nailed sidewise, and the roof covering, tar and gravel or composition; usually the fire, rear and end walls are of brick or concrete and the foundations of concrete.

Another type of engine house that has been used to a large extent is designed to accommodate a travelling crane; typical cross sections of this kind are shown, Fig. 239. The construction is generally reinforced concrete throughout, or a combination of steel shapes encased in concrete.

**Cost of Engine Houses.** — The size of engine houses varies from 60 to 105 ft. in depth. An 85-ft. house, which is about the average, would have an area of approximately 1700 sq. ft., or a cubic capacity of about 34,000 cu. ft. for the ordinary flat roof house.

*Approximate Cost.* — Approximate cost per stall for various designs, dimensions as above, previous to 1915:

(1) *Frame building:* Wood posts, cinder floor, *cedar sill foundation*, wood roof, \$1600 to \$1800. Average, \$1 per square foot, or 5 cents per cubic foot.

(2) *Frame building:* Wood posts, cinder floor, *masonry foundation*, wood roof, \$2000 to \$2200. Average, \$1.25 per square foot, or 6½ cents per cubic foot.

(3) *Brick building:* Wood posts, cinder floor, *masonry foundation*, wood roof, \$2400 to \$2600. Average, \$1.50 per square foot, or 7½ cents per cubic foot.

(4) *Brick building:* Steel and concrete posts, cinder floor, masonry foundation, mill construction roof, \$2800 to \$3000. Average, \$1.75 per square foot, or  $8\frac{1}{2}$  cents per cubic foot.

(5) *Masonry or concrete building:* Steel and concrete posts, brick floor, cedar sill foundation, concrete roof, \$3200 to \$3500. Average, \$2 per square foot, or 10 cents per cubic foot.

The wood roof for the first three estimates would consist of ordinary joists with double  $\frac{7}{8}$ -in. boarding on top.

The mill construction roof would consist of large wood beams, spaced at least 8-ft. centers with 3-in. plank on top.

The concrete roof would consist of reinforced concrete beams, at least 8-ft. centers with 3-in. concrete over, reinforced with expanded metal.

The above costs are for building one stall complete, and include heating, electric wiring and lights, steam, air and water pipes, smoke jacks, drainage inside the house, etc.

The approximate cost per stall of a few standard engine houses on a number of railroads previous to 1915 is given as follows:

APPROXIMATE COST OF ENGINE HOUSES.

No. of stalls.	Name of railway.	Depth of house.	Kind.	Diam. of turntable.	Total cost.	Approx. est'd cost per stall.
		Ft.		Ft.		
35	A. T. & S. Fé, T. C.....	92	Reinforced concrete.....	.....	\$158,000	\$4500
42	Wabash Ry.....	91	Wood.....	.....	84,500	2100
34	C. Jct. Ry.....	85	Concrete, brick and wood	.....	75,000	2500
40	L. S. & Mich.....	.....	Frame concrete fds.....	.....	132,000	3300
Std.	B. & M.....	75	Brick.....	.....	.....	1600
18	C. P. R.....	85	Concrete and steel.....	.....	63,000	3500
18	C. P. R.....	90	Concrete and mill cons...	.....	57,600	3200
13	Lake Shore & Mich. Southern.....	105	Concrete and mill cons...	90	.....	5000
16	Buff. Roch. & Pitts., T. C.....	103	Reinforced concrete.....	90	.....	.....
....	Ill. Central.....	100	Concrete and mill con...	.....	.....	.....
....	Western Maryland, T. C..	105	Reinforced concrete.....	100	.....	5000

**Wabash Engine House (Wood).** (Fig. 240.) — A 42-stall engine house of this design was erected at Decatur, Ill. It was built of wood and cost about \$2100 per stall; its construction was as follows:

*Construction.* — Inner circle posts 12'' × 12'', outer circle 8'' × 8'', depth of stalls 90 ft. 10 in.; outer wall filled with glazed

sash above window sills, below sills wall is made with an 8" x 8" base plate and a 6" x 8" sill directly under the window sash. To these are fastened expanded metal covered with a heavy coating of cement plaster, both inside and out. Inner wall

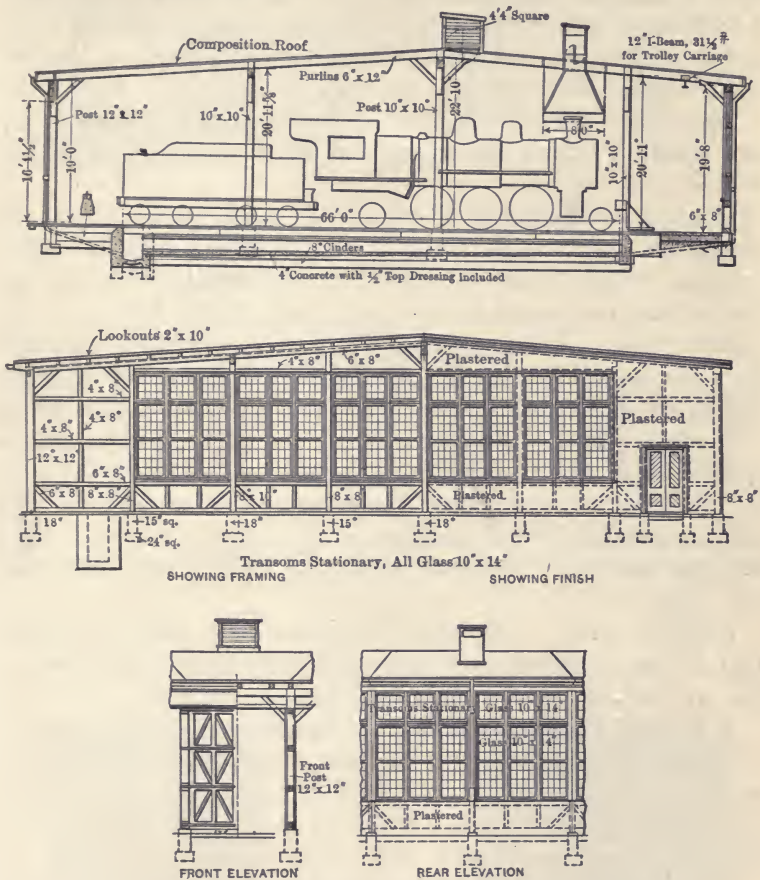

Fig. 240. Wabash Engine House, Decatur, Ill.

solid doors, and the short space between door and roof is finished same as outer walls. Post and wall foundations and pit walls are of concrete.

*Floor.* — Floor consists of 8-in. cinders, 4 1/2-in. concrete and 1/2-in. cement finish.

*Vents.* — Over each pit at the apex of the roof there is a wooden ventilator  $4\frac{1}{2}$  ft. square with wooden slats on all four sides.

*Smoke Jacks.* — Smoke jack 3 ft. square with steel angle frame; the portion extending below the roof is flared to form a hood 8 ft. long and 3 ft. wide. The angle frame is tied with  $\frac{3}{8}$ -in. round rods placed about 18 in. centers and the whole jacket is covered with expanded metal and cement to prevent the iron from rusting.

*Drop Pits.* — There are three drop pits each extending under two tracks. Two of the pits are for driving wheels and one for engine truck wheels.

*Heating.* — The house is heated by steam, with 2-in. pipes placed alongside the pit walls, four on each side.

*Light.* — The house is lighted by incandescent lamps, six lamps being suspended between each pair of pits.

*Air Pipes.* — Compressed air for power purposes is supplied by a compressor driven by a .75-horsepower motor and supplies 375 cu. ft. of air per minute. The main pipe overhead is  $1\frac{1}{2}$  in.

*Trolley System.* — Six feet from the outside wall there is suspended from the roof purlins a single line of 12-in. I-beams,  $31\frac{1}{2}$  lb. per foot, completely encircling the house. These support an overhead trolley, driven by an electric motor and having a capacity of 2 tons for transferring wheels, heavy castings, etc.

*Washout Plant.* — The system consists of a series of storage tanks, pumps, thermostats, and regulating valves and the operation and details are described on pages 508 and 522.

**A. T. & S. Fé Engine House (Concrete).** (Figs. 241 and 242.) — A 35-stall engine house of this design was erected at San Bernardino and Bakersfield, Cal., built of reinforced concrete, and cost about \$4500 per stall. Depth of stall 92 ft. from outer to inner wall, and inner wall is 123 ft. from center of turntable.

*Construction.* — These houses are of unusual construction, inasmuch as there is only one line of post supports inside the house, which practically divides it into two parts, one section of which is provided with a  $7\frac{1}{2}$ -ton travelling crane for stripping and assembling engines. The walls, columns, roof girders, roof beams and roof are of reinforced concrete. The pit walls are built of concrete reinforced with old boiler tubes.





DETAILS OF PIT CONSTRUCTION.

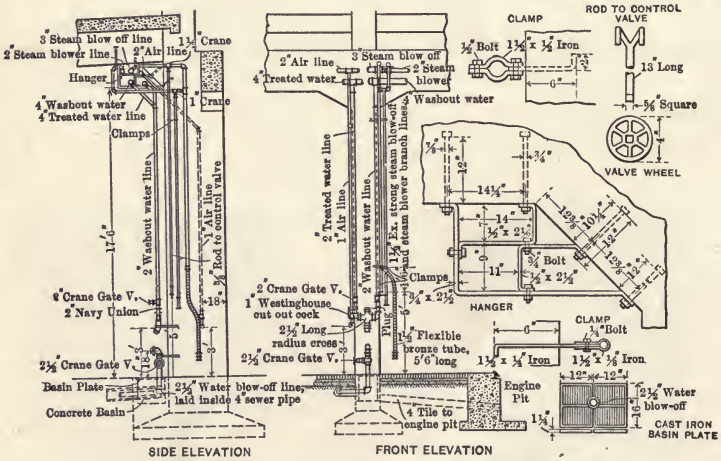
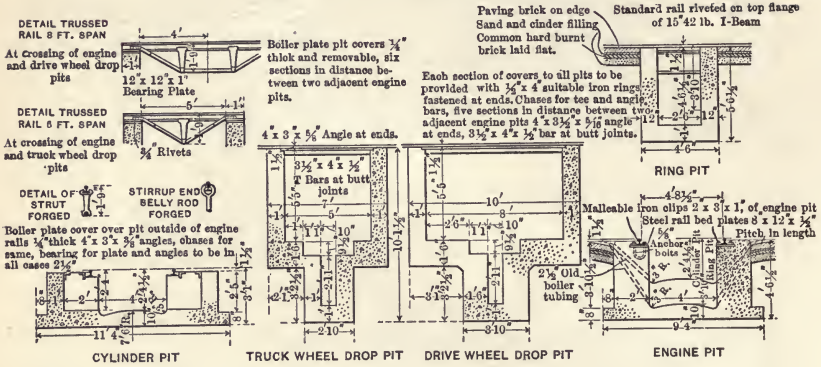

Fig. 242. Details, 35-stall Engine House, A. T. & S. F. Ry.

## DETAILS STEAM, AIR AND WATER PIPING.

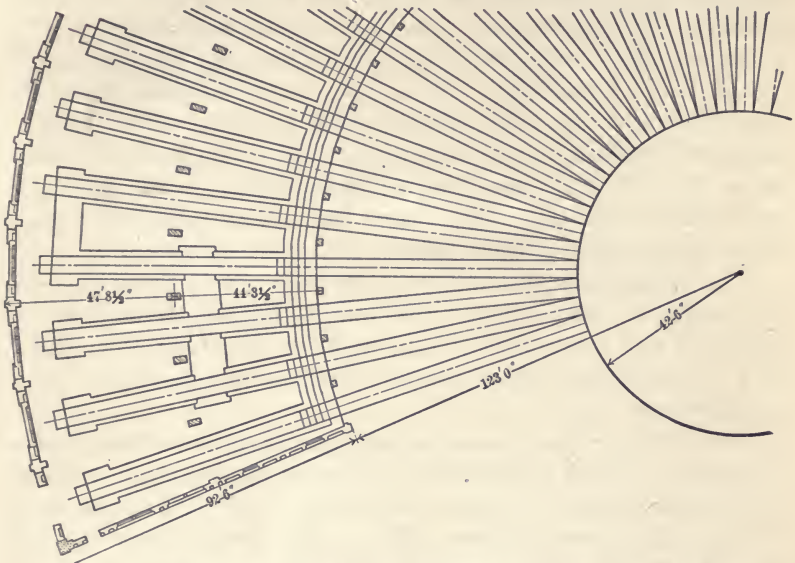

Fig. 242 (Continued). Partial Plan, 35-stall Engine House, A. T. & S. F. Ry.

*Floor.* — Floor consists of 8-in. cinders and a layer of common hard brick, on top of which is placed a bed of sand and cinder filling, on which is placed the finished paving brick.

*Vents.* — Over the high portion of the house is a 6' × 15' ventilator with adjustable louvers, encircling the entire house, which serve as smoke jacks also.

*Drop Pits.* — There are three drop pits, each extending under two tracks, also two truck wheel pits. The pits are so arranged that it is possible to remove driving wheels and truck wheels at the same time when desired.

*Heating.* — The house is heated by steam from mains in the ring pit, with pipes placed on either side of the engine pit.

*Trolley System.* — The house is provided with travelling crane with three D.-C. 220-volt direct-current motors. The bridge is equipped with a 7½-ton motor, speed 200 ft. per minute. The travelling hoist motor is 7½ horsepower, hoisting speed 10 ft. per minute, the rack with two horsepower giving a speed of about 200 ft. per minute.

The crane is designed to run on two concentric tracks, and they are so proportioned at either end of the bridge that both ends of the crane travel together on their respective circles.

*Steam, Air, and Blow-off Lines.* — The air line enters the round house through the wall nearest the boiler room and 27 ft. from the floor line and extends along the side of the bottom chord of the main truss to the opposite end of the same and down to a 2" × 2" × 2½" tee, from which run 2-in. lines horizontally each way to the last post at each end of the house, with 1-in. branch lines down at each post.

The 2½-in. steam blower line enters the round house as near as possible to the air line and follows it alongside of the bottom chord of the main roof truss and down to a 2" × 2" × 2½" "T" from which a 2-in. line runs horizontally supplying 1½-in. branch lines.

The 2-in. horizontal lines are given a slight fall each way from the 2½-in. tee, and provided with a ½-in. drain pipe at the extreme ends leading down to a point about 2 ft. from the floor line and directly over a sewer basin. A ½-in. globe valve is provided on the drain pipe about 12 in. from the end.

The steam blow-off line is of 3-in. pipe running parallel to the air line and the steam blower line with 1½-in. branch lines extending down each post to 6 ft. 6 in. from the floor. The connection to the locomotive is made by a flexible bronze tube 5 ft. 6 in. long.

The treated water and the washout water lines are carried overhead, in the same brackets which support the other lines mentioned. These lines are 4 in. with 2-in. branch lines extending down the posts and terminating in a 2-in. long radius cross, which is provided with a plug in the top and a hose connection in the bottom, making it possible to wash out a boiler with ordinary water and fill it with treated water with the same hose connection.

A 4-in. water blow-off line is laid in the ring pit and connected to each stall by a 2½-in. pipe entering the engine pit through a hole provided in the basin plate. A 4-in. drain tile is laid from the bottom of the posts and the engine pit to carry away any drip or overflow that might occur from the water and steam lines.

**Smoke Jacks.** — The only desirable opening in an engine-house roof is that required for the smoke jack. Skylights rob the house of a good deal of heat, and very soon get blackened up.

Ventilators, also, unless operated by mechanical suction or fan, are of little use.

The smoke emitted from engines, when mixed with steam, forms sulphuric acid that destroys all exposed metal. All material, therefore, for openings of any kind should be such as will not readily be affected by smoke fumes, and while there has been a steady improvement in the design of engine houses, the smoke jack problem has not yet been satisfactorily solved.

*Design.* — The old style of telescopic jack that was arranged with counterweights so that it could be pulled up and down over the engine stack has almost disappeared, having been supplanted by the wide-mouthed rigid jack that carries off the smoke to better advantage and allows some leeway in the spotting of the engine. There has also been a marked increase in the area of the smoke flue and a tendency to decrease the height of the stack above the roof; also from the nature of the materials used a square section as well as a round and oval one has developed. To conserve the heat in winter, dampers are used to some extent, but this feature is gradually being dispensed with; obviously the smoke stack without a damper, also serves as a good ventilator.

The present day jack, therefore, may be said to consist of a wide-mouthed hood 8 ft. to 12 ft. long or more, preferably not less than 36 in. wide; the hood tapers on two or all four sides and connects with the smoke stack. The smoke stack varies from 30 in. to 42 in. in cross section, either round or square, and extends 6 ft. or more above the roof, terminating with a cowl or opening at the top to serve as an exit for the smoke.

When the hood is narrow and short in length or has a flat taper, a ventilating feature at the roof is sometimes provided by making the jack in two pieces, that portion above the roof being made a little larger than the portion below the roof so as to produce the effect of a box within a box for a square jack, or a pipe within a pipe for a round jack, the space between serving as an exit for any smoke getting from under the hood. This feature, however, is not generally provided for hoods that

are wide and long. Most of the designs that are used to any great extent at the present time are patented and the illustrations and descriptions that follow are from drawings that are protected by patents.

**Materials.** — The materials now commonly used in the construction of smoke jacks are cast iron, asbestos, and wood. A large number of railroads have used all three with indifferent success and the item which has figured largest in the problem has not been the first cost but the maintenance repairs.

*Cast Iron.* — Cast-iron jacks have been used for the past twenty-five years, but as their size increased, the excessive

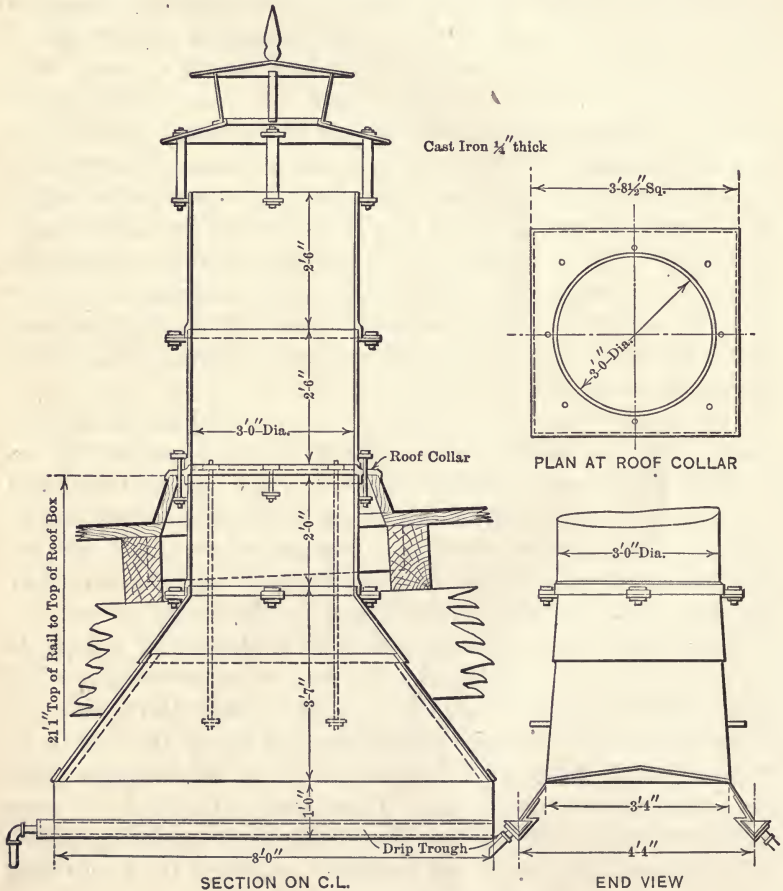

Fig. 243c. Cast-iron Smoke Jack.

weight to be carried by the roof has given some concern; this, however, has been largely overcome by using light castings built up in sections secured and supported with cast-iron bolts, as per Fig. 243c. With this material it is necessary to provide for condensation and usually a drip trough is placed at the bottom of the hood on either side and the drip is conveyed far enough over to escape the engine by means of small pipes. It has also to be kept well painted to protect it from rust. An ordinary cast-iron jack with hood 36 in. wide and 8 ft. long and 36 in. diameter stack will weigh approximately 2500 lb. and the average cost is about \$125 erected complete in place. Under ordinary conditions the average life of a cast-iron jack given by a number of railroads is from 8 to 10 years.

*Asbestos.* — Asbestos in sheet form has been used to a large extent during the past ten years and although the general experience with this material has been far from satisfactory its light weight and fire-proof qualities are very inviting. On a number of railroads it has been found that it will not stand up against steam, smoke, and weather conditions for any considerable length of time without sponging and peeling and a large maintenance expense is entailed in its upkeep.

No special specification has been devised for its manufacture and the material supplied is very variable in quality. When first used for smoke jacks the sheets were thin and soon gave out. The heavier sheets last much longer but moisture and steam play havoc with it as soon as the least weathering or wear takes place.

The portion under the roof where it is protected from the weather lasts a good deal longer but is apt to be brittle and easily broken.

The jack built of sheet asbestos, Fig. 243a, is square in cross section, having four wood posts or asbestos angles at each corner to which the sheets are attached with copper nails or rivets. The hood is also made with a wood or asbestos angle frame. It makes a light form of smoke stack that entails little or no extra weight on the roof.

A jack, 3 ft. square and 6 ft. high above roof with 3' × 8' long hood, using  $\frac{3}{8}$ -in. asbestos sheets, will cost in place \$100

ASBESTOS VENTILATING SMOKE JACK

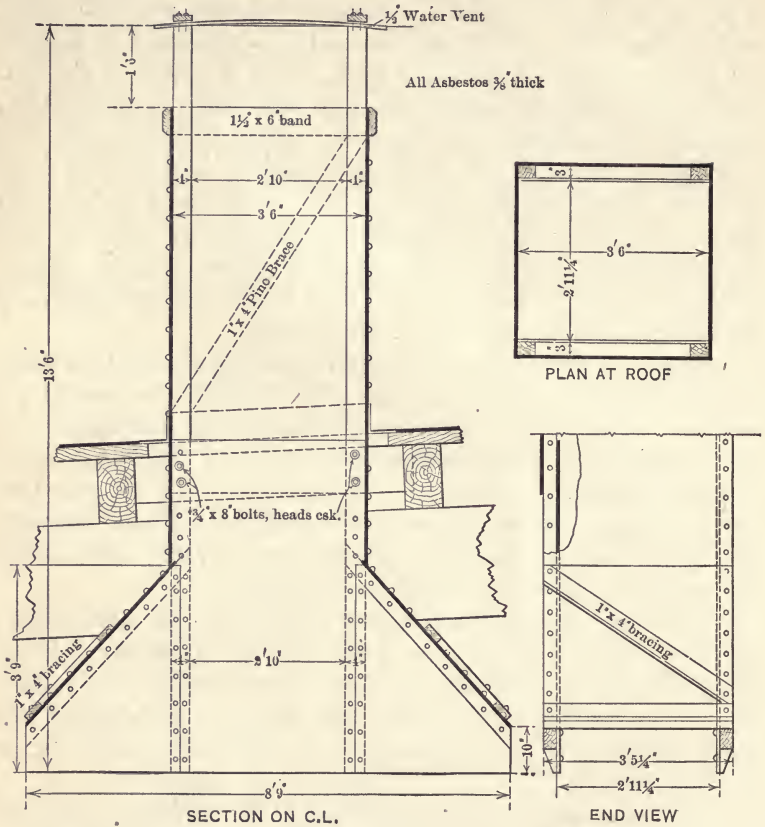

Fig. 243a.

and the average life given by a number of railroads is from 3 to 5 years.

This type of jack has been used extensively on the C. P. R. The supports shown are 2" x 4" timbers but asbestos angles have also been used reinforced with metal. The asbestos sheets are used in standard sizes and the joints are simply butted together. A coat of metallic paint is given all outside surfaces after erection.



Some types of cast asbestos jacks have been quite successful and satisfactory, and though somewhat lighter than cast iron they cost about the same, or about \$125 to \$150 complete in place. (Fig. 243.) The material also for this type of jack seems to be very variable, failures have been numerous, and usually they are purchased under a guarantee; 8 to 10 years is given by some users as their average life.

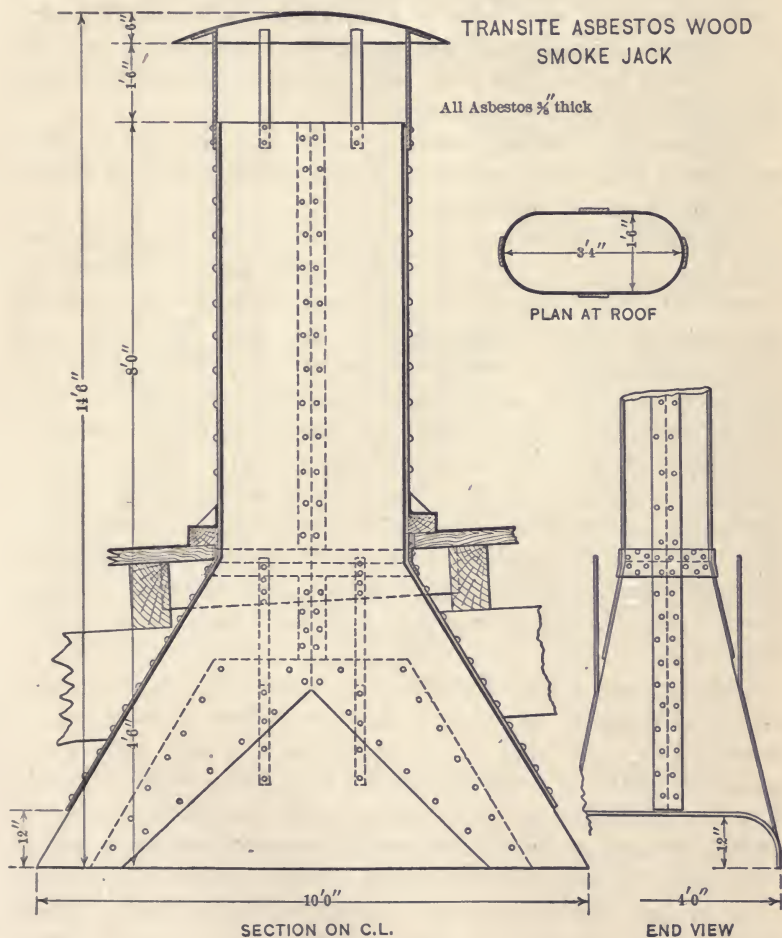

Fig. 243.

*Wood.* — Wood jacks were probably the first kind to be built and there is a tendency at the present time to revert back to this material, which may be accounted for by the desire of many designers to eliminate iron of any kind from the present-day construction of engine houses, owing to the rapid deterioration that takes place from the smoke and sulphuric gases that are prevalent around structures of this kind.

The flimsy construction of wood jacks in the past made them a fire hazard and they failed to stand up to the service required. To overcome the fire risk the wood has been treated but the cost is said to be high. In place of treated wood fire-proof paint has given good satisfaction.

There are also wooden jacks in service that are held together and bound at the corners with cast-iron clamps, etc., that appear to be giving satisfactory results.

A wooden jack built on the mill-type method of construction, Fig. 243b, made of 2" × 3" timbers laid flat one against the other and nailed sidewise throughout, produces a very strong and rigid jack that requires no guy supports. The nails used in its construction are well protected by the method adopted in putting it together, each layer of timber protecting the nails of the previous piece so that when completed no iron work of any kind is exposed to the smoke fumes. This type of jack is standard on the C. P. R. The timbers before being put together are saturated in a bath of fire-proof paint. The hood is 3 ft. wide by 8 ft. 6 in. long with a 3-ft. square smoke stack extending 6 ft. above the roof, and the jack complete in place costs about \$75 and is expected to last as long as the engine house itself.

**Chimney and Induced Draft.** — In residential districts where smoke is regulated by civic by-laws, or where it would be of considerable annoyance to the community, a high chimney is sometimes built to carry the smoke to a point where it would not be objectionable. The smoke jacks instead of extending above the roof are connected with a large smoke duct carried over along the roof to the chimney. The sections of the ducts vary in size according to the number of smoke jack connections it has to carry. To create sufficient draft to carry away the smoke from the main duct, induced draft fans are used.

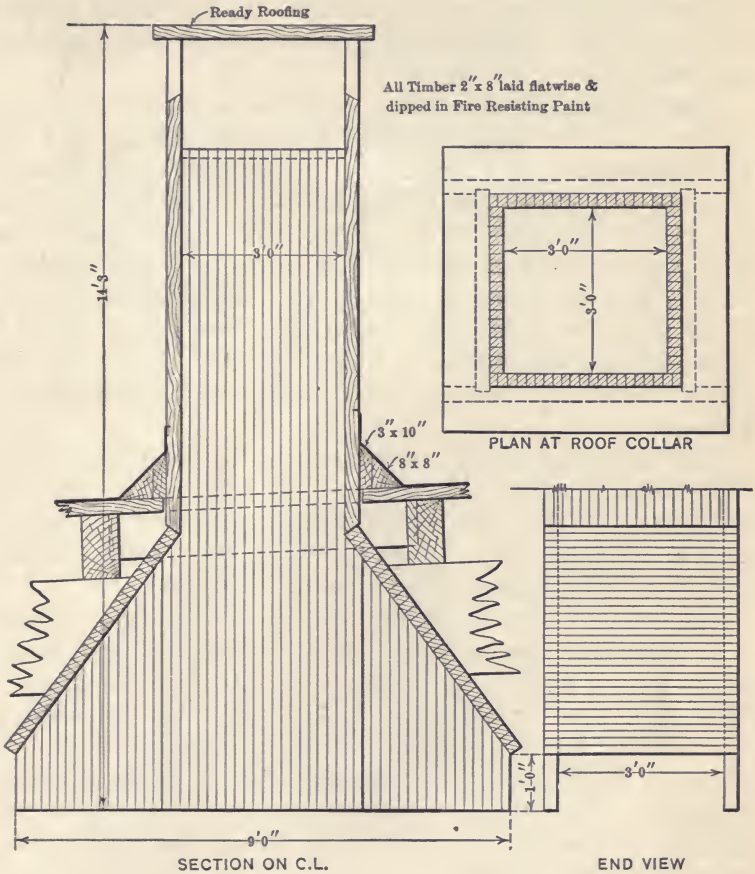

Fig. 243b. Wood Mill Type Smoke Jack, C. P. R. Standard.

This type of jack has been used to a very large extent on the C. P. R. during the past few years and has given good satisfaction. All of the material is subjected to a bath of fireproof paint before assembling and it is built up in crib fashion as described on page 514.

This is an expensive installation and the fact that iron work of any kind is liable to be attacked and destroyed very quickly by the gas and sulphuric fumes the installation must be designed with the greatest care as to the material used and the method of making the various connections to provide the maximum protection.

*Smoke Precipitation.* — The precipitation of smoke by the use of high potential electricity and a suitable electric field has been successful in a large number of practical applications in chemical and other works, but has not so far been applied directly in the collection of smoke from engine houses, and while the complete elimination of the smoke can be obtained by this process the initial cost for ordinary round house purposes would be very high, but in situations where smoke is regulated by civic by-laws it would probably be cheaper and more satisfactory than the induced draft system already described.

Fig. 243d illustrates an installation of this kind, the electric field for which has been suggested by J. A. Shaw, electrical engineer, C. P. R. The smoke jack is of the mill type design with an asbestos hood. It is estimated that this installation including a high-tension transformer will cost \$500.

The removal of smoke is accomplished by passing it through a precipitation chamber, made up of a number of pipes firmly joined to end headers, the wires passing through the pipes as illustrated. The precipitation depends upon the intensity of the electric field, the quantity and temperature of smoke, the degree of initial ionization, and the type of corona discharge employed. The soot or residue settles at the bottom of the chamber and can be removed when desired through the door provided for the purpose.

This jack is a combination of Mill and asbestos construction, the asbestos being used only for the portion which is protected from the weather. The smoke precipitator is supported on 4 in. by 3 in. wooden posts resting directly on the roof. The main beams on which the jack rests are designed to carry the extra loading entailed.

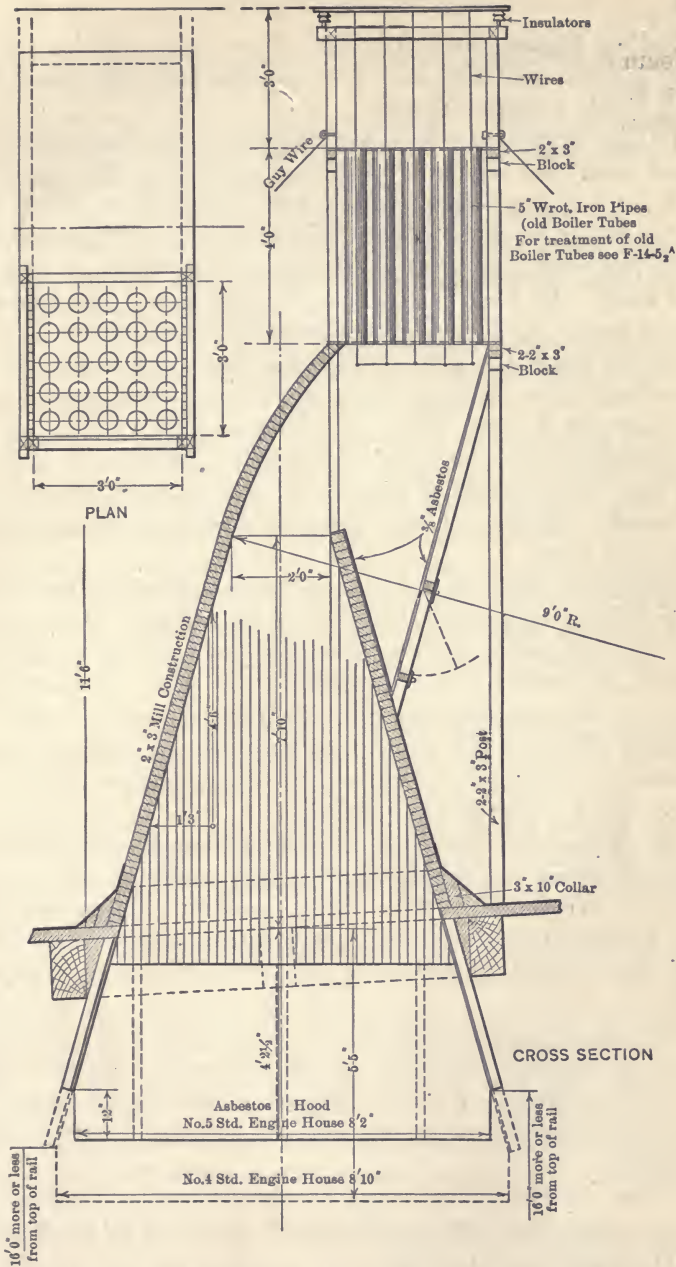

Fig. 243d. Electric Precipitation Mill Type Smoke Jack, Cross Section.

**Heating Engine Houses.** — In the heating of round houses there are two methods in vogue, the hot air system and the direct steam vacuum method.

*Hot Air Heating.* — The heating apparatus when possible is placed about the center of distribution either in the engine or boiler house or in a separate annex, and consists of an engine, fan, and heater, set up and anchored on concrete or wood foundation.

The heater is made up of a series of coiled steam pipes enclosed by a sheet steel jacket, to which is attached a steel plate fan, usually driven by a vertical or horizontal steam engine.

The fan draws the air over the steam coils and forces the hot air through pipes or ducts to any part of the house desired.

On account of smoke fumes corroding any iron work that is not well protected, the air ducts are usually placed underground. The main duct is built of reinforced concrete, and the branches are usually tile pipe, though wood is often used on account of cheap first cost.

Usually the main duct runs around the back of the house, the inside face of foundation wall serving as one side. It is necessary that all inside surfaces should be as smooth as possible, without projections of any kind inside the duct. Branches are taken off the main with long radius bends and run down between pits with offsets to the engine pits, and risers at points where it is desired to admit hot air to heat the balance of the house, the outlets being controlled by dampers.

The ducts absorb a portion of the heat and are also subject to dampness from condensation. The main point is to provide means for keeping them dry. This is done by grading the ducts so as to drain to the air outlets, and placing covers in the main duct that can be opened to let out the dampness at favorable times.

*Capacity and Approximate Cost.* — The capacity of the heating apparatus depends upon the size of the house. In any event it is always necessary under ordinary conditions to figure the units large enough so as to provide for a reasonable future house extension.

For the ordinary run of engine houses the supply of hot air per minute varies from 2000 to 3000 cu. ft. per stall at a fan speed of 200 revolutions per minute.

Figuring 2250 cu. ft. of air per minute, a 20-stall engine house would require the following:

Steel plate fan 8 ft. in diameter by 4 ft. wide. Theoretical capacity, 45,000 cu. ft. of air per minute at 200 revolutions.

Side crank steam engine 8" × 12".

Heating coils, 6700 lineal feet of 1-in. pipe capacity.

Approximate cost of the above installed, with concrete foundation walls and timber floor for the fan and heater, varies from \$2800 to \$3400, or on an average \$150 per stall.

The cost of the main ducts, branches, risers, dampers, etc., in place averages from \$100 to \$180 per stall, or the cost of the complete installation \$250 to \$350 per stall.

The sizes of the mains and branches have to be figured out for the volume of air carried, and are usually given by the manufacturers of the heating outfit. No boilers, or steam main connections from the same, are included in the estimate.

A feed water heater and pump with valves and connections arranged to receive the drip of the heating system for boiler feed is often added, also a vacuum pump in connection with the hot air heater to relieve pipes of air, etc., and give good steam circulation.

The cost of a 100-horsepower heater with feed and vacuum pump, including valves and connections set up complete for the above heating apparatus, varies from \$500 to \$750.

The heater is generally arranged to condense the exhaust from the fan or other engines for boiler feed, and when omitted, steam traps are provided for removing the water of condensation to the drain.

In exceptionally cold weather, the air is taken from the engine house and reheated, openings being provided in the air chamber so that this can be accomplished. It is not an ideal method, but under exceptional conditions is often necessary.

*Steam Heating.* — The ordinary method is a low pressure direct steam heating system, adapted to use and utilize all exhaust steam available from the engine and boiler house, with such additional live steam as may be necessary from boiler during severe weather.

From the exhaust header the main steam supply is run around either the front or back of the house, usually in the underground

ducts carrying the air and water pipes, with branches to the pit and wall coils, including a return main to which all coils are connected.

The steam main reduces in size as it goes along proportionately as the amount of radiation is decreased, and the size of the return pipe is increased proportionately as the coils are added to it. To relieve heating coils of water of condensation and air, the return pipe is connected to a vacuum pump located in pit near the boiler, the water of condensation being discharged into a feed water heater, and from the heater to the boiler by a feed pump. The exhaust header is connected into heater full size of header, with relief pipe from heater to roof fitted with a back pressure valve.

Valves are applied in steam main or mains near exhaust header, between vacuum pump and heater, steam supply from boiler to vacuum, and boiler feed pumps.

The following areas and weights of pipe may be of service when figuring the square feet of radiation required and the size of pipe that will best suit the service desired.

TABLE 129. — OUTSIDE SURFACE AREAS AND WEIGHTS OF PIPES.

LENGTH OF STANDARD WROUGHT-IRON STEAM PIPE CONTAINING ONE SQUARE FOOT OF OUTSIDE SURFACE, FROM ONE-EIGHTH TO TEN INCHES.

Size of pipe.....	$\frac{1}{8}$	$\frac{1}{4}$	$\frac{3}{8}$	$\frac{1}{2}$	$\frac{3}{4}$
Feet of pipe containing one square foot of outside surface.....	$9\frac{440}{1000}$	$7\frac{75}{1000}$	$5\frac{557}{1000}$	$4\frac{322}{1000}$	$3\frac{697}{1000}$
Size of pipe.....	1	$1\frac{1}{4}$	$1\frac{1}{2}$	2	$2\frac{1}{2}$
Feet of pipe containing one square foot of outside surface.....	$2\frac{203}{1000}$	$2\frac{302}{1000}$	$2\frac{00}{1000}$	$1\frac{602}{1000}$	$1\frac{306}{1000}$
Size of pipe.....	3	$3\frac{1}{2}$	4	$4\frac{1}{2}$	5
Feet of pipe containing one square foot of outside surface.....	$1\frac{91}{1000}$	$\frac{955}{1000}$	$\frac{849}{1000}$	$\frac{765}{1000}$	$\frac{629}{1000}$
Size of pipe.....	6	7	8	9	10
Feet of pipe containing one square foot of outside surface.....	$\frac{577}{1000}$	$\frac{505}{1000}$	$\frac{444}{1000}$	$\frac{394}{1000}$	$\frac{355}{1000}$



TABLE 129 (Continued).—OUTSIDE SURFACE AREAS AND WEIGHTS OF PIPES.

WEIGHT PER FOOT IN LENGTH OF STANDARD SIZE WROUGHT IRON STEAM PIPE FROM ONE-EIGHTH TO TEN INCHES.

Size of pipe.....	$\frac{1}{8}$	$\frac{1}{4}$	$\frac{3}{8}$	$\frac{1}{2}$	$\frac{3}{4}$
Weight per foot in length in lbs.....	$\frac{2.43}{1000}$	$\frac{4.22}{1000}$	$\frac{5.61}{1000}$	$\frac{8.45}{1000}$	$\frac{11.26}{1000}$
Size of pipe.....	1	$1\frac{1}{4}$	$1\frac{1}{2}$	2	$2\frac{1}{2}$
Weight per foot in length in lbs.....	$\frac{16.70}{1000}$	$\frac{22.58}{1000}$	$\frac{26.94}{1000}$	$\frac{36.67}{1000}$	$\frac{51.73}{1000}$
Size of pipe.....	3	$3\frac{1}{2}$	4	$4\frac{1}{2}$	5
Weight per foot in length in lbs.....	$\frac{75.47}{1000}$	$\frac{91.55}{1000}$	$\frac{107.38}{1000}$	$\frac{124.92}{1000}$	$\frac{141.64}{1000}$
Size of pipe.....	6	7	8	9	10
Weight per foot in length in lbs.....	$\frac{181.67}{1000}$	$\frac{234.10}{1000}$	$\frac{283.48}{1000}$	$\frac{341.77}{1000}$	$\frac{401.41}{1000}$

*Heating Surface and Equipment Required.*—For ordinary engine houses the amount of heating surface usually installed varies from 1 to  $1\frac{1}{2}$  sq. ft. per 100 cu. ft. of enclosed space; probably  $1\frac{1}{4}$  sq. ft. is a fair average.

For one stall having a capacity of 34,000 cu. ft. the heating surface would be  $\frac{34000}{100} \times 1\frac{1}{4} = 425$  sq. ft., or 680 lin. ft. of 2-in. pipe per stall.

The best distribution is to put four pipes on each side of the engine pit and the balance as coil radiators on the roundhouse walls.

Sometimes five or six rows of pipe are placed on the engine pit walls, but this method is not recommended, as it will usually be found that so much pipe will impede circulation, and as a result the bottom pipes are generally cold.

The pipes are supported by cast or bent steel pipe hangers about 6 ft. apart. Usually wood plugs or strips are built into the wall to which the pipe supports are attached by lag screws, the screws serving in the case of the bent steel hangers as supports on which the pipes rest.

For a 20-stall engine house the steam main would be 5 in. for the first ten pits, 4 in. for the next six, and 3 in. for the balance. They are hung from strap hangers supported by rods passing through the ducts about 7-ft. centers, or on floor rollers with

expansion bends. The return would be 2 in. for the last four pits,  $2\frac{1}{2}$  in. for the next six, and 3 in. for the balance.

The heater not less than 100 horsepower, and made sufficiently strong to carry 10 lb. of steam pressure. The vacuum pump  $3\frac{1}{4}'' \times 5\frac{1}{2}'' \times 4''$ , all brass lined, and feed pump  $4\frac{1}{2}'' \times 2\frac{3}{4}'' \times 4''$  duplex.

*Approximate Cost.* — The cost for complete installation varies from \$225 to \$300 per stall without ducts. Only a portion of the cost of ducts would be chargeable to the heating, as the same ducts would be used to run the live steam, air and water pipes. No boilers are included in the above estimates. See under "Boiler Houses" for cost of boilers, etc.

**Washout System.** — By using a series of hot water tanks suitably connected with pipes, valves, pumps, etc., the steam and water can be taken from locomotives and stored in tanks to be reused for washing-out purposes and refilling when desired.

By this method a large saving of time is effected in washing out and refilling locomotive boilers, and as the water is hot, the work is done without danger from unequal expansion to the tubes, stay bolts, or fire box, and in addition 50 per cent of the water is saved and reused, and it is possible to take the water from a boiler and refill with a fresh supply in 30 minutes without removing the fire. To blow off, wash the boiler, and refill it with a fresh supply, and to obtain 100 lb. steam requires about two hours. The old method of blowing off and letting the water waste to the drain requires from 8 to 10 hours to wash out, refill, and get 100 lb. steam.

The system consists of one or a series of storage tanks, with blow off, hot water, washout, and filling, pipe lines, including live steam piping to the tanks, also valves and connections; where a series of tanks are used for washing out, refilling and superheating, pumps are required to maintain pressure at the hose nozzles for filling purposes.

*Approximate Cost.* — Usually the piping is furnished to a few pits only for washing-out purposes, and to each pit if refilling and washout system is installed. The cost varies from \$6000 to \$25,000, depending upon the capacity and requirements of the plant.

TABLE 129a. — WASHOUT, BOILER FEED AND VACUUM PUMPS.

(Average standards: for ordinary conditions.)

DUPLEX STEAM PUMPS — WASHOUT AND BOILER FEED.

To be brass fitted throughout.	Diam. of steam cylinder.	Diam. of water cylinder.	Length of stroke.	Cap. in imp. gals. per min. at 50 strokes.	Cap. in imp. gals. per hour at 50 strokes.	Pressure per sq. in.	Diam. of pump suction.	Diam. of pump discharge.	H.P. required.
	12''	7''	12''	160	9600	100 lb.	6''	5''	50
(Ordinarily used in washout plant — emergency fire pump.)									
5½'' 6''	3½'' 4''	6'' 7''	20 30	1200 1800	..... .....	2½'' 3''	2'' 2½''	Boiler feed pump.	

DUPLEX STEAM VACUUM PUMP — FOR HEATING SERVICE.

4''	6''	5''	Up to 4,000 sq. ft. radiation.
6''	8''	10''	Up to 12,500 sq. ft. radiation.
8''	10''	12''	Up to 22,500 sq. ft. radiation.

*Washout System, Wabash Ry.* — A system installed in the 42-stall engine house built by the Wabash already described will serve as a typical layout for this character of work.

Pipes are supplied for blowing off and filling up boilers for 42 stalls and for washing of boilers through 15 stalls. The overhead main consists of an 8-in. pipe for blowing off, one 4-in. pipe for filling up, one 3-in. pipe for washing out, two circulating pipes, each 2 in. in diameter for the washing out and filling system, and one 6-in. superheater pipe. At each central post between the pits there are two 2-in. drop pipes, one for blowing off and one for filling boilers, and in addition in each of the 15 pits there is one 2-in. drop pipe for washing out. The water for washing out is used at a uniform temperature of 120° F., and for filling at 180 to 190 degrees with three boiler washers and five helpers, by the aid of this system, it is possible to wash out 18 engines in 24 hours.

The system consists of a series of storage tanks, pumps, thermostats and regulating valves, and the operation of the system is as follows: The blow-off line is connected to the water leg of the locomotive and the pressure of steam in the boiler forces the water and steam into a washout tank which is so arranged that

the steam is separated from the water, going into a separate tank where it is condensed and used for filling purposes. The mud and water goes into the lower tank where the water is filtered so as to be available for use again. The water in the lower tank varies from 140° F. to 200 degrees, and it flows from here to another tank which is automatically controlled by a thermostatic valve to admit cold water to temper the water for washout purposes so that a uniform temperature of 120° F. is supplied. Electrically driven triplex pumps, controlled automatically by a mechanical device, maintain a constant pressure of 80 lb. on each of the hose's nozzles, regardless of the number of nozzles in use. These pumps have a capacity of 350 gal. of water a minute and the operation of a valve in a drop pipe in the roundhouse starts the pumps into action.

After the engine is washed out, it is filled with water taken from the upper tank. This water is maintained at a temperature of about 180° F. The capacity of the pump for filling is 350 gal. per minute, and under a pressure of 175 lb. it takes only about 10 minutes to fill a boiler. The system is so arranged that it is possible to change the water in a boiler and give it a fresh supply in 20 minutes without removing the fire. It is also possible with the largest locomotives to blow off, wash the boiler, fill it again, and obtain 100 lb. steam pressure in 1 hour and 45 minutes. With the use of hot washing water and filling water, maintained at uniform temperature, it is possible to do this quick work without danger from unequal expansion affecting the firebox, tubes or staybolts. Under the old system of washing out and filling it takes from 5 to 8 hours to wash out and fill an engine and get up 100 lb. steam pressure. The saving in water used amounts to about 60 per cent, as under the old system the water was allowed to run to the sewer while in the new system it is used over and over again.

An auxiliary to this filling system consists of an additional tank which acts as a superheater. The water is forced by pumps through this superheater, which is jacketed with live steam from the locomotives, by means of which the temperature of the water is raised from a minimum of 200 degrees to a maximum of 320 degrees. This gives ordinarily a steam pressure of 100 lb. in the boiler of the locomotive when supplied with this

superheated steam, and it is sufficient pressure to use for the blower or to move the engine without building a fire.

**Steam, Air and Water Pipes.** (Fig. 244.) — One of the most important features about an engine house is the installation of the steam, air and water pipes.

The steam is required for heating purposes and engine supply, the air for engine and shop supply, and the water for washing-out purposes and fire service.

For the ordinary run of engine houses up to 22 stalls the following sizes are commonly used:

Live steam main 3 in. diameter, branches  $1\frac{1}{2}$  in. diameter.

Air pipe main  $1\frac{1}{2}$  in. diameter, branches  $1\frac{1}{4}$  in. diameter.

Water service main 3 in. diameter, branches 2 in. diameter.

The branch pipes where connections are desired are arranged so as to be attached to the inside posts, and terminate about 5 ft. from the floor. The steam pipe is equipped with a valve and air-brake coupling, the coupling being used for hose connection to convey live steam to engine boilers when necessary.

The air pipe is fitted with a Westinghouse air brake and coupling.

The water pipe is equipped with gate valve and drip cock for fire purposes, also a globe valve and hose coupling for engine boiler service; in addition a short length of pipe extends above the fire valve, with elbow, to which are attached 50 ft. of rubber-lined hose and 18-in. fire hose nozzle; the hose and nozzle are supported on a stand with movable brackets secured to the posts and encased in wood frame with glass front.

A valve is placed on each branch pipe near the main so that any branch supply can be cut off for repairs without interfering with the rest of the house.

Owing to smoke fumes corroding the iron and the annoyance from dripping it is considered the best practice to place the pipes in underground ducts instead of stringing them overhead inside the house.

The ducts are arranged so as to be easily accessible for repair purposes and valve service, and are usually built of wood or concrete.

The wood duct, though cheap in first cost, is high in maintenance. On account of being subjected to the moisture from the



ground on the outside, and excessive heat inside, it soon rots out, and has to be renewed every few years.

To eliminate the maintenance charges entirely, it is necessary to build the ducts of concrete or masonry, or such material as will be permanent; and to be successful it is also necessary that its cost will compare favorably with the price of wood.

The "Thurber" patented system of rib concrete ducts is said to accomplish this result, and the method of installation is as follows:

The main ducts carry the steam, air, water and heating pipes, run between and connect each engine pit, either at the front or back of the house, making a continuous passage throughout, so that no breaking or cutting of walls for the passage of pipes is necessary; they are made 2 ft. 9 in. wide and 2 ft. 9 in. deep.

The ducts carrying the branch steam, air and water pipes connect with the main duct between alternate pits, and extend back to the end post so as to serve two pits, the pipes being carried up the post face. The branch ducts are 1 ft. 6 in. wide and 1 ft. 6 in. deep.

The method of building the ducts consists in placing iron tee sections at varying intervals, not exceeding 3 ft., and setting up concrete slabs between; the slabs fit into the bottom pockets and bear against the iron sides of the ribs, and are held by bolts or rods at the top, the rods being used to hang the pipes inside the ducts. The floor can be made in slabs or built in concrete in the usual way. All slabs are laid in cement mortar.

The approximate cost of steam, air and water pipes installed complete, not including the ducts, averages from \$55 to \$80 per stall.

**Electric Wiring and Lights.** — Probably the best method of wiring engine houses is to enclose all wires in conduit pipe and sealed boxes, running the mains and branches on the roof, an improved type of which is the "Ravelin" patented system. By this method all wiring and joints are protected from smoke and gas fumes, and the work of wiring is simplified, and as all parts are accessible, repairs can be made easily.

Usually three incandescent 16-candlepower drop lights are placed between each stall, with a plug receptacle connection on each post for portable hand light. The lamps are protected by wire screens over the lights.

Switches are placed on the back or front walls for each stall or series of stalls.

Outside, arc lights are generally used, strung on poles in convenient position. The number vary with the size of the house and the amount of light desired.

*Approximate Cost.* — The cost of complete installation varies from \$50 to \$75 per stall.

**Inspection Pits.** — Inspection pits are provided on the incoming tracks where the engines are inspected as soon as they reach the terminal and before the engineer leaves. The advantage is in having the repairs started at the earliest possible

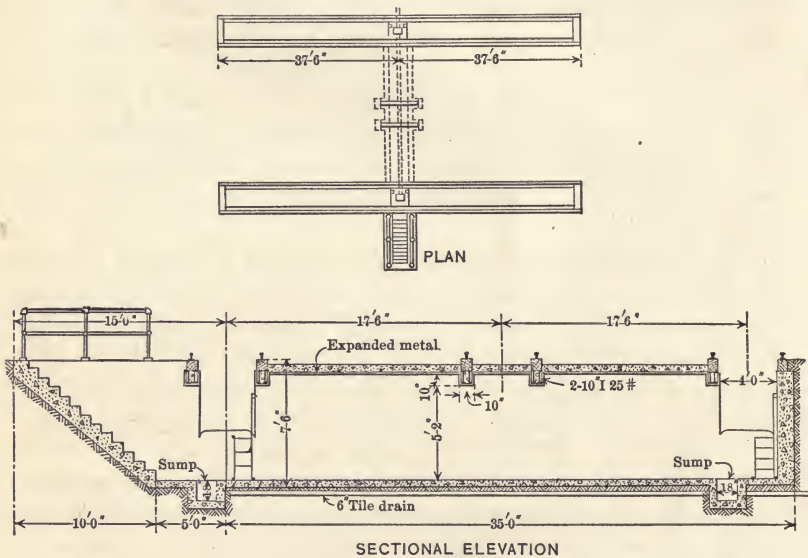

Fig. 245. Plan and Section of Inspection Pits, C. & A.

moment; the inspectors make minor repairs, such as tightening nuts, etc., or have assistants to do this work. A good deal of the routine inspection of locomotives is done in the inspection pits, relieving the tracks of the roundhouse to a large extent.

*Inspection Pits, C. & A.* — Two engine inspection pits, built by the Chicago & Alton at Glen, Ill., are shown on Fig. 245. The pits are located just west of the coal chute, are 75 ft. long and are built of concrete. A concrete stairway at the center of



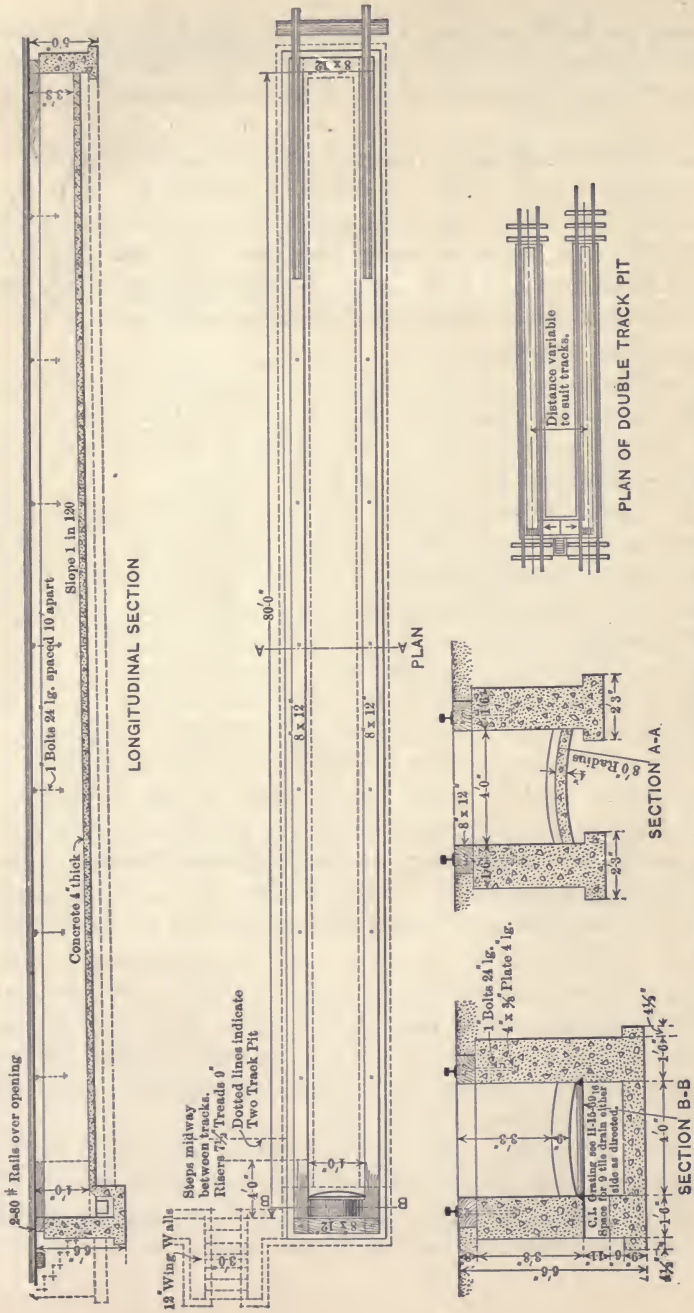

Fig. 246. Plan and Section of Inspection Pits, C. P. R.

the east pit leads down to a tunnel reaching both pits, passing under an intermediate track to connect with the pit on the west. Access to the pits is secured by short ladders leading from the tunnel.

The approximate cost of the pits complete is about \$1500.

*Inspection Pits, C. P. R.* — A double pit as built by the C. P. R. is shown, Fig. 246. The walls and floor are of concrete with 12" × 16" wall plates to carry the rails. The entrance stairway is located at one end midway between the pits. The cost of an 80-ft. double track pit including ordinary drainage is estimated at \$1200.

**Ash Pits.** — Ash pits are required at divisional and other points so that ash pans of locomotives can be cleaned out.

The pits are usually placed convenient to the coal and water supply, and within easy reach of the turntable.

The time required to clean a locomotive ash pan is from twenty to sixty minutes, depending on weather and other conditions, hence the type of ash pit to select depends on the number of engines to be handled and the time in which it has to be done.

*Construction.* — The walls are usually built of stone or concrete or 12" × 12" cedar timbers. When concrete is used a lining of fire brick is built on the inside face of walls, and when of timber old boiler plate is used. The lining of fire brick or other protection is necessary to protect the walls from the detrimental effect of hot ashes. On account of the wave action when the engines travel over the pit it is difficult to keep the rails anchored to the masonry, and for this reason wood stringers, or cast-iron rail chairs 3-ft. to 4-ft. centers, are used frequently. The wood stringers are protected by a covering of sheet metal.

Water is used to cool the ashes, and this necessitates a water service with hose connection, valves, etc., and proper drainage. A sump hole 12 in. wide and 12 in. deep at one end of the pit, with the floor dished so as to drain to the sump, serves the purpose, the outlet to drain being placed on the side of the wall about 6 in. above the floor of sump.

*Shallow Track Pit.* (Fig. 247.) — This type of pit is built in long lengths, and necessitates sufficient help being on hand to remove the ashes promptly. It is also used for temporary work during construction and occasionally on main lines.

Approximate cost, \$5 to \$7 per lineal foot complete (Fig. 247).  
 Approximate cost, \$9 to \$12 per lineal foot complete (Fig. 248).

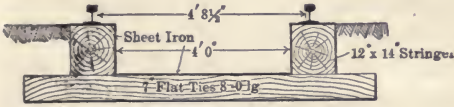

Fig. 247. Shallow Ash Pit.

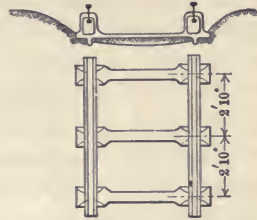

Fig. 248. Cross Iron Ash Pit.

*Deep Track Pit, Closed Sides.* (Figs. 249 and 250.) — The deep ash pit is constructed somewhat after the ordinary engine house pit, built 33 ft. long and over. When two pits are placed on the same track they should be at least 50 ft. apart. The ashes may be dumped directly into the pit and then shoveled out by hand, or small ash cars or buckets may be used under the engines to catch the cinders, the buckets being hoisted out by crane or air hoist when the track is clear.

Approximate cost, \$8 to \$10 per lineal foot without buckets or hoist. Cost, \$17 to \$35 per lineal foot with buckets and hoist. A pit 33 ft. long with two ends would average \$300 complete.

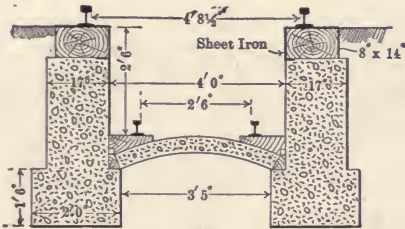

Fig. 249. Deep Ash Pit.



Fig. 250.

At points where large ash pits are necessary there are two types in general use. One is the open side pit operated by hand, and the other the mechanical type operated by compressed air. The former is used to a much greater extent, however, than the latter which would make it appear that the open side pit, hand-operated, is in the long run the most economical.

In the depressed type of cinder pit, proper drainage is a matter of first importance. From the designs illustrated it will be

noted that the depression of the loading track varies from 4 ft. 6 in. to 9 ft. 0 in., and, generally speaking, where proper drainage can be obtained, there will be a saving in labor in the handling of ashes from the pit to the car the lower the loading track is depressed. The depth, however, must necessarily be regulated by the drainage facilities and very few situations lend themselves to an unusual depth in the matter of drainage.

If conditions were such in the handling of ashes that the operation was continuous instead of intermittent, it is quite likely that a mechanical type of ash handling apparatus would be much more economical than any hand-operated method. As it is there are many cases where the mechanical type of apparatus in its simplest form has proved to be more economical, where conditions have fitted the machine, when the equipment is such to be low in first cost, easy to maintain and inexpensive to operate.

**Deep Ash Pit, Open One Side.** (Fig. 251.) — This pit is similar to the closed type excepting that the pit is open on one side and the outer rail is supported by steel or cast-iron posts. The ashes may be dumped and shoveled out by hand or picked up by crane or other mechanical device.

*Approximate cost, \$35 to \$50 per lineal foot.*

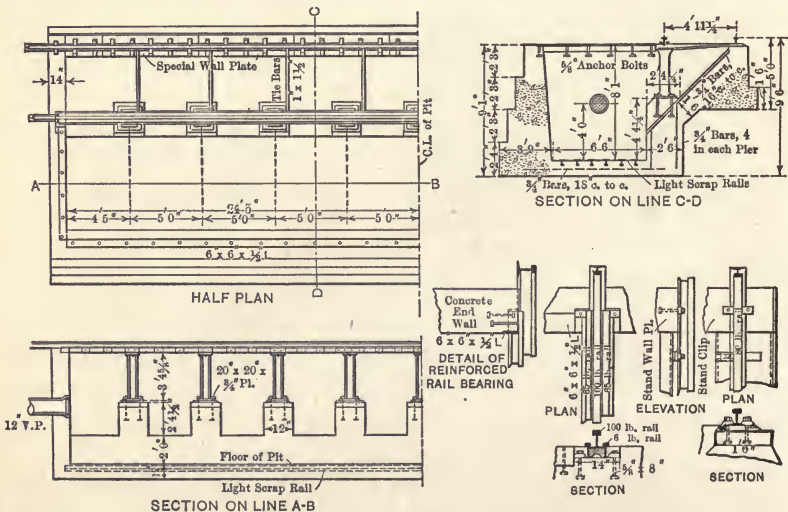
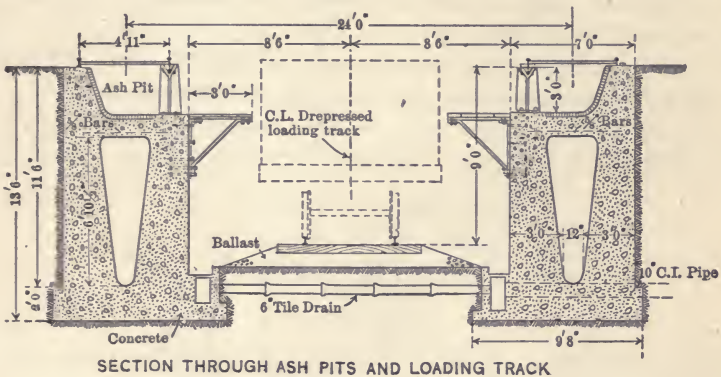

Fig. 251. Cinder Pit, Lake Shore & Michigan Southern Ry., Hillsdale, Mich.

Double Cinder Pit, Chicago & Alton Ry. at Glen, Ill. — Fig. 252 illustrates a double cinder pit built by the C. & A. at Glen, Ill., with a depressed track in the center. It is located close to the roundhouse. The pits are 200 ft. long enabling six engines to clinker at one time. The engine tracks are supported on heavy concrete walls, hollowed out in the center, as shown in the illustration, and filled with sand to save concrete.

The loading track is depressed 9 ft. below the running tracks, and platforms 3 ft. wide are built out on each side at the elevation of the bottom of the cinder pits, on which workmen may



SECTION THROUGH ASH PITS AND LOADING TRACK

Fig. 252.

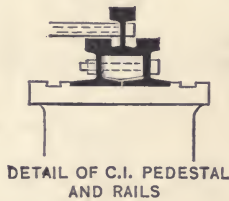

DETAIL OF C.I. PEDESTAL AND RAILS

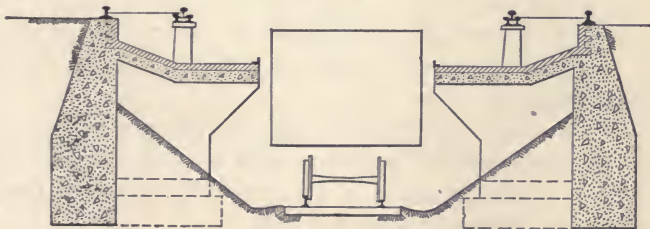

Fig. 253. Depressed Ash Car Track.

stand while loading the cinders. The platforms are covered with steel plates nicked with cold chisels to insure safe footing. The running tracks are 12-ft. centers and drainage is provided on either side of the depressed loading track.

The approximate cost of this type of cinder pit for estimating purposes may be figured at \$100 per running foot.

Fig. 253 is another type of depressed ash pit, with pedestal supports and cantilever floor.

**Mechanical Ash Plants.** — Ashes are best handled in bulk, so that most mechanical plants are arranged to dump the ashes directly into small cars or buckets under the engine tracks, the small cars running on tracks at right angles to the pit so that they can be pulled out and hoisted by trolley, crane, or other device and automatically dumped into the cinder car.

*Gantry Crane.* (Fig. 254.) — The trolley beam is hinged at one end and is worked by air cylinder, with sheaves fastened to

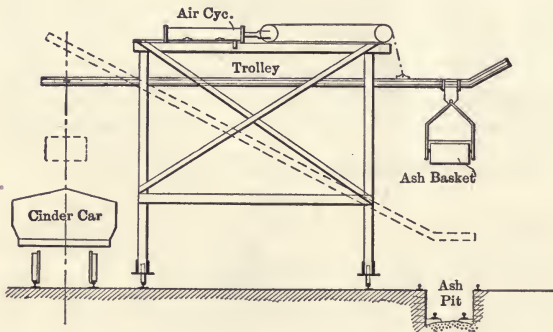

Fig. 254.

the gantry frame. The crane is moved along the track by geared hand wheels, one on each side, and the air is conveyed to the cylinder by hose pipe suspended on trolleys on an overhead wire. The supply of air is generally obtained from the engine or boiler house close by.

When the engines are off the ash pit, the gantry frame picks up the filled ash baskets and runs them by trolley to the ash car, where they are automatically dumped. By lowering the boom the basket is returned to the ash pit.

Approximate cost complete, with 6 ash baskets, \$800 to \$1000.

*Ord Ash Pit.* (Fig. 255.) — The ash baskets are placed under locomotive ash pan and pulled out from the side and hoisted by air crane and dumped without interfering with the movement of engines. The rails on which the ash baskets run are made of pipe, in which steam circulates, keeping the pit free of snow and preventing the water used in cooling the ashes from freezing.

Approximate cost of a single-track, 30-ft. ash pit with crane and four ash baskets complete, \$1200 to \$2000.

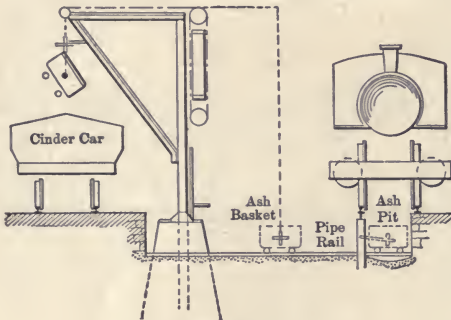

Fig. 255.

**Water Filled Ash Pits.** — B. & O. R. R. water-filled double track ash pit at Chicago is shown, Figs. 256 and 256a. The pit is of reinforced concrete 150 ft. long by  $28\frac{1}{2}$  ft. wide over all and 13 ft.  $3\frac{1}{2}$  in. deep. Cross walls are introduced at either side to support the 20-in. steel and concrete encased girders which carry the rails. The rails are 100 lb. section. The pit receives the ashes discharged from the locomotives when cleaning fires and the ashes are removed by a grab bucket handled by a locomotive crane. The bottom of the pit is reinforced with old rails to protect the floor from being damaged by the grab bucket and the corners of the crosswalls are protected with angle irons for the same reason. Four valve boxes, alongside the pit, supply water, the overflow pipe being about 15 ft. from the floor level and leads into a sump pit with a 6-in. outlet.

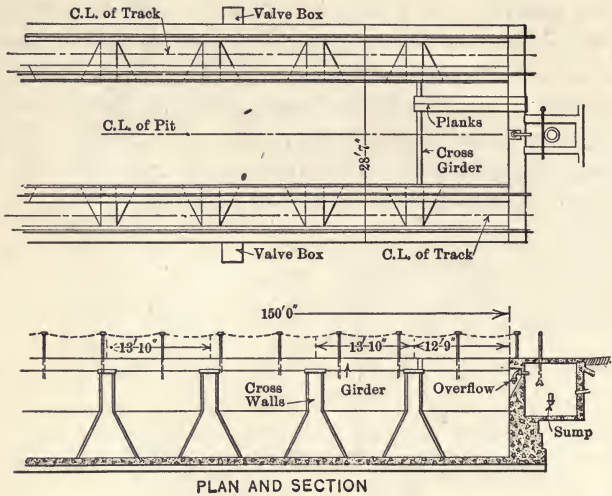

Fig. 256. Water Pit with Gantry Crane.

The length of ash pits will depend upon the number of engines it is desired to handle at one time, and as the service is usually very intermittent, the engines coming bunched generally for a short period of time, the pits are made long enough to accommodate the maximum service desired within certain periods.







Figs. 257 and 258 show a pneumatic patented cinder conveyor of the Robertson type. The track on which the cars are placed for receiving the cinders is on the same level with the entire engine track. The cinders from the engines are dumped into the iron car below the track. This car is then hauled up the incline by compressed air and automatically dumps the cinders into a gondola or a cinder dump. This incline is made of ordinary T rails. The drainage problem is easily solved owing to the shallowness of the pit under the engine track.

The power is usually available from the engine house for its operation.

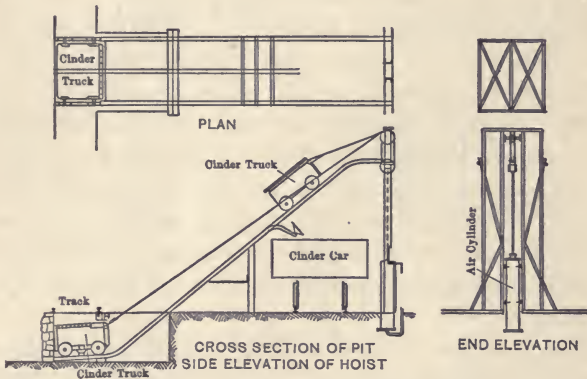

Fig. 258. Pneumatic Cinder Conveyor.

**Locomotive Turntables.**—The length of wheel base of the longest engine to be turned and the position of its center of gravity are the conditions which usually determine the length of the turntable. For ease of turning the locomotive should be balanced and to determine this length the most unfavorable condition, with the tender empty and the boiler filled, should be assumed. The length required then becomes twice the distance from the center of gravity to the rear tender wheel with an additional foot or so at each end for a margin to facilitate spotting and to clear wheel flanges.

The standard lengths of the ordinary turntable, on various railways, are from 80 to 100 ft.; 90 ft. is about the average length.

The designs are confined chiefly to the deck and half through type of plate girder construction, built to carry the full load on the center and provided with four cast steel end wheels, as well as a center pivot device. The table is built of steel fabricated in the shops the same as ordinary bridge work, and is shipped on cars ready to be dropped into place at the site. As stiffness is most essential for economical operation the depth of the table should be sufficient to prevent deflection.

The center piers and circular walls are built usually of concrete though stone is used when it can be had at less cost and the foundations are dry. The center pier is generally capped with cut stone or granite or reinforced with old rails.

It is recommended that a recess in the circular wall be provided for inspection of wheels and making repairs, and circle rail seat should be extended at two points immediately opposite each other to afford support for jacks for raising table and examining center; this will render the operation much safer than cribbing on yielding ground. When there is any doubt as to the nature of the ground spread foundations should be provided or piling when the former is not economical. Some roads provide that the center pier shall be piled in all cases excepting in rock foundation.

Paving the pit floor helps to keep it clean, assists the drainage, and snow can be removed with less trouble. Sometimes steam pipes encircle the floor of the pit to melt the snow in winter time. This also enables the snow being dumped into the pit from the engine house approaches and helps in keeping the engine tracks clean.

At points where tables are not used to any extent the circle wall is only built at the entrance and runoff, using ballast under the ties for the balance of the circular rail, sloping the ground where no retaining walls exist and grading the floor of the pit on the natural ground, covered with a layer of cinders rolled and dished so as to drain readily.





The C. C. & O. Ry. standard turntable pit is shown in Fig. 259. The turntable is one hundred feet in length of the plate girder type. The entire foundation is built of concrete reinforced with old rails. Two kinds of center pier foundations are given, type "A" for firm earth and type "B" where piles are necessary. The floor of pit is finished with paving brick laid on edge and grouted in cement. Drainage is provided by grading the floor of the pit to a catch-water basin near the center, which connects with the drain. Where piles are used they must be below water level, or creosoted.

The Virginia Ry. standard pit is shown in Fig. 260. The turntable is a plate girder design one hundred feet in length. The foundations throughout are built of concrete and are supported on piles where the engineer so directs. The concrete is reinforced with one-inch round steel rods, when the foundations extend to rock the rods are omitted. The floor of the pit is finished in concrete dished to drain to a sump pit near the center.

☛ The Chicago, L. Shore & Eastern Ry. 70-ft. turntable pit is shown in Fig. 261. The foundations are of concrete and the floor of the pit is of cinders graded to drain to sump pit. The table is of the Pratt hinged type.

The Chicago, & N. W. Ry. 80-ft. turntable pit is shown in Fig. 262. The foundations are of concrete, with piles supporting the center pedestal, cut stone being used for the pedestal seat. On the center pier the average pressure per square foot is 6000 lbs. and the average pressure per pile 32,000 lbs. For the main walls the average pressure per square foot is 2300 lbs. The bottom of the footings may be varied and determined by local conditions. The floor may be of concrete, brick or cinders graded to drain.

The C. M. & St. P. Ry. 85-ft. turntable is shown in Fig. 263. The foundations are of concrete with a stepped footing around the circular wall. It will be noted that a recess is provided in the main wall for access to table wheels and should be located away from tracks. A casting is used to support the table on the center pier. A section for concrete pit with wooden wall is also shown.







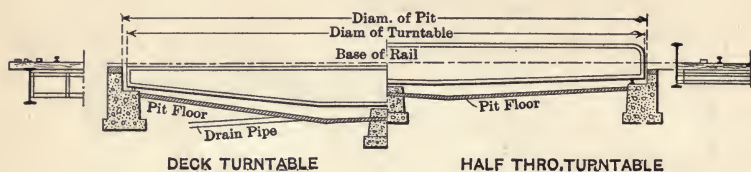

The cost and design of a number of turntables follow:

COST OF TURNTABLES.

Spans, ft.	Kind of table.	Railway.	Kind of foundations.	Approx. total cost ready for rail.
70	Deck plate.....	Chic. & N. W.	Concrete	\$7,332
75	Deck plate.....	Phil. & Reading	Concrete	7,785
80	Through plate.....	Nor. Pacific	Concrete	7,600*
80	Through plate.....	Nor. Pacific	Concrete	6,750
80	Through plate.....	Col. & Southern	Concrete	6,390
70	Deck plate.....	B. & M. Ry.	Concrete	6,500
80	Deck plate.....	N. Y. N. H. & H.	Concrete	9,000
70	Through plate.....	C. P. R.	Concrete	7,700
70	Through plate.....	C. P. R.	Wood	4,800
85	Deck plate.....	C. P. R.	Concrete	9,000
100	Deck plate.....	C. C. & O.	Concrete	10,000†

\* Estimated.

† High cost due to excavation being done in freezing weather.

APPROXIMATE COST OF MOTOR DRIVES FOR TURNTABLES.

Kind.	Horsepower.	Name.	Cost.
Electric.....	20 H.P.	Induction motor, 200 v. 2 phase	\$1500
Electric.....	.....	Nicols tractor (Nor. Pac.)	1223
Gasoline.....	8 H.P.	Gasoline motor	1000
Air.....	.....	N. P. Ry.	470

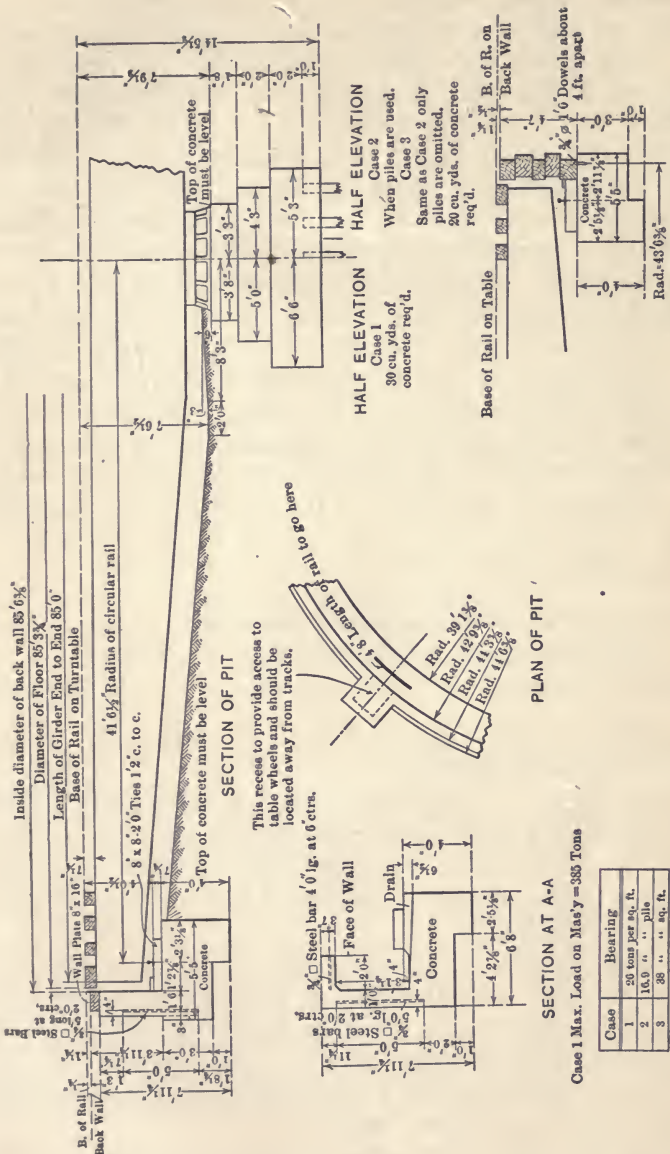

Fig. 263. Chic. Mil. & St. P. Ry.—85-Ft. Turntable.

**Turntable Motor Drives.** — Where many locomotives are handled the work of a turntable is usually intermittent, rushing for a short period and then at a standstill. To expedite the movement during the rush period it is very important to do the work in the shortest time possible. The length of time required to turn the table by hand depends largely on the number of hands available to do the turning and even with the handles full the work cannot be done as quickly as with a motor, and the three types in use are electric, gasoline and air.

*Electric Motors.* — Where generators are installed in the engine house or machine shop close by, or where electric power can be obtained cheaply, the electric motor is usually installed and though higher in first cost it is low in maintenance. The feed wires are run underground in conduit and brought up in the center of the turntable to a collecting switch arranged so that contact is made in all positions of the turntable, the motor being mounted on the center of the turntable and connected direct.

*Approximate Cost.*

20-horsepower induction motor 200 volts

2 phase 60 cycles, installed complete. . . \$1500

Cost of operating and power averages . . . 10 per month

*Northern Pac. Ry.* — Electric tractor cost \$1104.37; installation, \$115.86; total, \$1220.23.

*Gasoline Motor.* — Approximate cost. 8 horsepower gasoline engine operating a 65-ft. table at Reading on the Phila. & Reading Ry. cost about \$100 and turned from 75 to 80 engines per 24 hours at a cost of \$165 per month. This includes labor, oil, gasoline and repairs.

*Air Motor.* — The air motor is said to be very efficient if properly installed and arranged to take proper adhesion on circular wall. The supply of air is obtained from the locomotives or from the air reservoir near-by. On account of the time required in making couplings, the air motor is slower in operation than the electric or gasoline machine.

*Northern Pac. Ry.* — Air motor in use at Jamestown, N. D., cost at St. Paul, \$450; installation, \$19.81; total, \$469.81.

### Boiler Houses and Machine Shops.

The ordinary boiler house is usually built behind the engine house, or as an annex to it, principally to supply steam, air, and water to the engine house proper, and incidentally to supply heating for other buildings and cars in the yard if necessary. For a medium sized locomotive terminal the building generally consists of machine, engine, and boiler rooms, with locomotive foreman's offices, registry room, and lavatory on one side of the machine room, having a small gallery for light stores over. The boiler room is made sufficiently large to hold two or three batteries of boilers, with a coal bin on one side which is filled from cars through the openings above.

*Approximate Cost.* (Fig. 264.) — The average cost of boiler houses for the building only ranges from \$1.75 to \$2.50 per square foot; for the one illustrated the cost would be \$6000 to \$7000.

For boilers and equipment 100 to 150 per cent extra.

Two 100-horsepower boilers erected complete \$3500 to \$4000.

Engine room equipment \$3000 to \$5000.

*Construction.* — Masonry foundation walls to five feet below ground, face walls common brick, stone, or concrete, with arches over doors and windows. Roof 8" × 14" beams at 8-ft. centers, covered with 3-in. plank, and tar and gravel on top. Office inside finished with hardwood floor, ordinary trim, and plastered walls and ceilings.

Machine room: hardwood floor, walls and woodwork whitewashed; boiler room: brick floor, with wood plank over coal bin, walls and woodwork whitewashed.

The ordinary locomotive type of boiler is generally used in units of 100 horsepower, with mechanical draft or large chimney, the boiler room being made large enough to hold an additional boiler in case of future extension.

The machine room equipment generally consists of an engine and air compressor and a small lathe, planer and saw, with benches fitted up for convenient use.

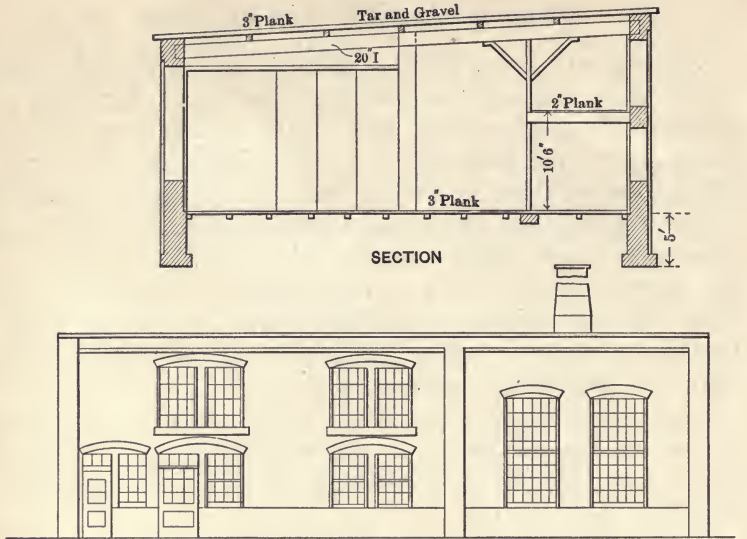

ELEVATION

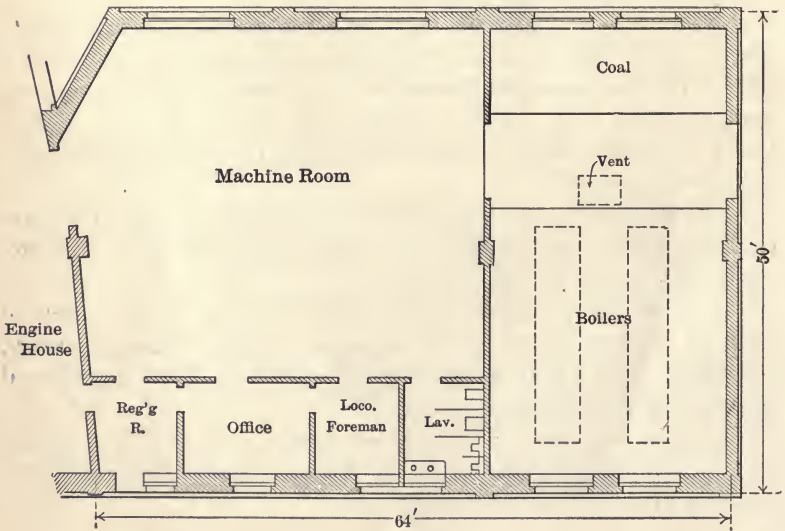

PLAN

Fig. 264. Boiler House.

**Boiler House Chimneys.** — The ordinary boiler house chimney stacks are sometimes built of steel, but where the boiler capacity is fairly large permanent chimneys are erected.

The steel stacks are usually independent, one being supplied for each boiler, and an ordinary size for 100 to 125 horsepower boiler is 30 in. diameter by 80 ft. high. They usually last from two to three years.

The permanent chimneys are built to accommodate the maximum number of boilers likely to be used, and it is preferable to do this even though the chimney may be too large for the time being as they can be regulated by dampers.

The area of the chimney for a given power varies inversely as the square root of the height, and the average height of an ordinary boiler house chimney at locomotive terminals is 125 ft.

*Cost of Chimneys.*

A steel stack 30 in. diam., 80 ft. high, for 100–125 H.P. boiler, will cost approximately, in place.....	\$225.00
A permanent radial brick chimney, 100 ft. high from ground, 54 in. clear diam. at top and 5 ft. deep foundation under the ground for 400 H.P., will cost approximately.....	2200.00
A permanent radial tile chimney, 125 ft. high from ground, 66 in. clear diam. at top and 5 ft. deep foundation under ground for 600 H.P., will cost approximately.....	3000.00
An older type of brick chimney for a terminal boiler house, 48 sq. in. opening at top and 113 ft. high from boiler house floor to top of chimney, cost.....	3500.00
A brick chimney for a grain elevator, 48 sq. in. opening at top and 150 ft. high from floor line to top of chimney, cost.....	4500.00
Fig. 265 illustrates a Weber reinforced concrete chimney built on the Ill. Cent. R. R. at Centralia, Ill., to accommodate a total boiler capacity of about 1500 H.P. The chimney is 90 in. diam. at top and 212 ft. high. The approximate cost is estimated at.....	5000.00





**Storehouses.** — At divisional, terminal, and other points storehouses are necessary to receive and store supplies for engine, car, and general service, for repair and operating purposes. It is important that its location provide facilities for receiving and shipping heavy material at a minimum cost for switching and handling.

On account of the class of equipment handled, a fire, while it may be covered by insurance, does not take care of the loss by not having the material to take care of running repairs.

The house is usually a frame structure on masonry, cedar sill, or post foundation, divided up with shelving and racks to hold the miscellaneous articles usually kept in stock, with an office in one corner for the storekeeper; to this may be added a counter if desired.

Sometimes the store and oil house are combined, or the oil house is placed in close proximity to the storehouse so that both can be looked after by the storekeeper.

APPROXIMATE COST OF STOREHOUSES COMPLETE, INCLUDING PLATFORMS, ETC. (Fig. 266.)

Size.	Wood foundation and floor.	Concrete foundation and concrete floor.
30'×30'×13' high	\$900.00 to \$1200.00	\$1500.00 to \$1800.00
45'×30'×13' high	1300.00 to 1500.00	2100.00 to 2500.00
60'×30'×13' high	1800.00 to 2100.00	2800.00 to 3300.00

*Construction.* — Fig. 62 illustrates a small storehouse 30' × 30' with platform. The house can be extended by adding 15-ft. bays.

Concrete foundations taken below frost, walls filled between with sand or good ballast well puddled and finished on top with concrete or wood floor. Framing consists of 2" × 6" studs 2-ft. centers, with 1-in. rough boards and siding, and building paper between on the outside and sheathed on the inside. The roof is made of 4" × 12" rafters at 7 ft. 6 in. centers, covered with 3-in. plank and tar and gravel. Shelvings and racks are provided to suit the class of goods kept in stock.

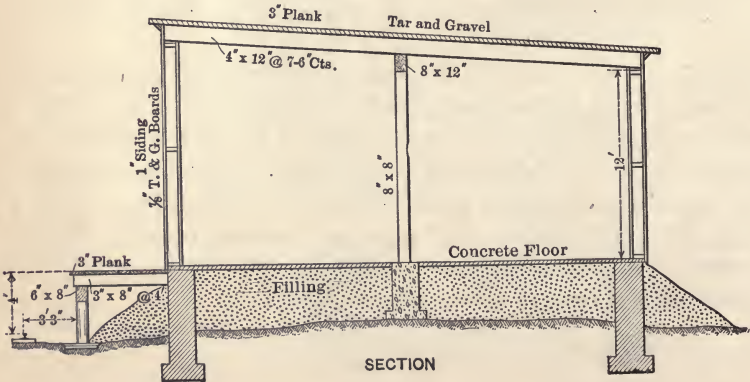
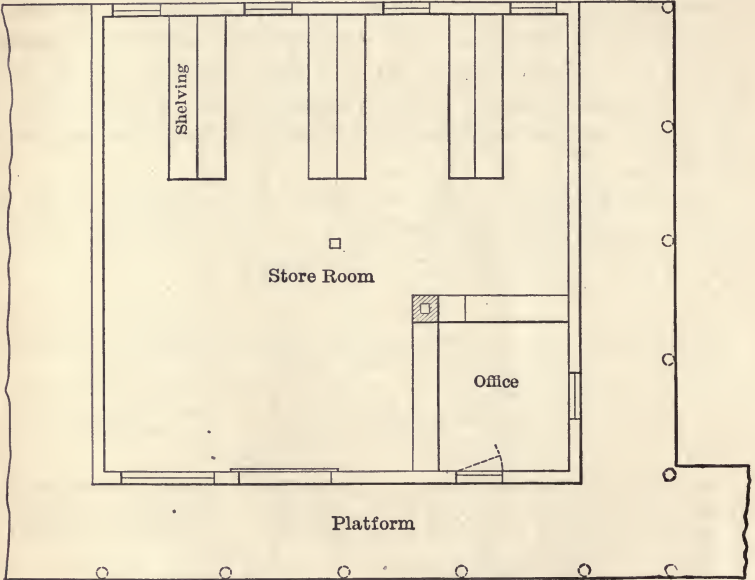

Fig. 266. Storehouse.

*Approximate estimate: (Fig. 266.)*

Quantities.	Material.	Labor.	Total unit.	Cost.
50 cubic yards excavation.....	.....	.....	\$0.50	\$25.00
54 cubic yards masonry (rubble).....	\$2.00	\$3.00	5.00	270.00
14,500 feet B. M. lumber, per thousand.....	18.00	17.00	35.00	507.50
Doors and windows.....	42.50	20.00	.....	62.50
Hardware.....	20.00	15.00	.....	35.00
Roofing.....	24.00	26.00	.....	50.00
900 square feet concrete floor and filling....	0.08	0.12	0.20	180.00
Brick chimney.....	8.00	12.00	.....	20.00
Painting and glazing.....	20.00	25.00	.....	45.00
Shelving.....	100.00	70.00	.....	170.00
				\$1364.00
Supervision and contingencies.....				136.00
				\$1500.00
900 square feet platform at 15¢.....				135.00
Total.....				\$1635.00

\$1.65 per square foot with masonry foundation and concrete floor.

\$1.50 per square foot with masonry foundation and wood floor.

\$1.25 per square foot with wood foundation and wood floor.

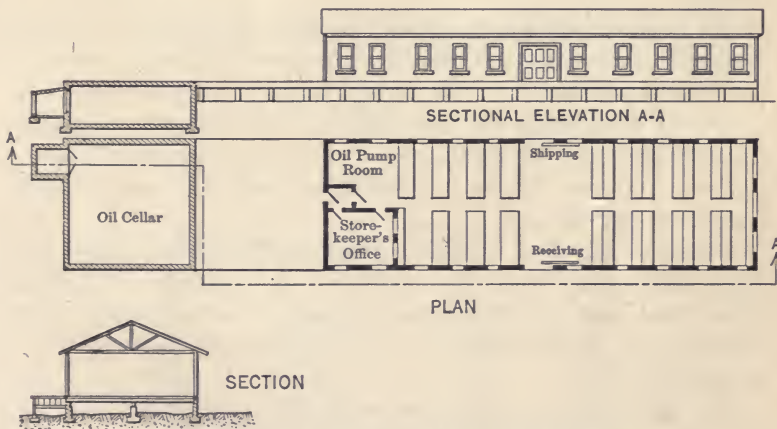

Fig. 267. R. S. A. Arrangement of Sub-storehouse.

A one-story house recommended by the Railway Storekeepers Association is shown, Fig. 267.

The office is located at the front of the house; the size should be sufficient to accommodate the help required, allowing 64 sq. ft.

for each clerk. No basement is shown, but if it is necessary to take care of hose and material that deteriorates if kept in too dry a place, a basement is a great convenience and when built should have an independent entrance from the outside as well as a stair and hoist inside.

In addition to the storeroom, an oil cellar located some distance from the storehouse and connected by a platform is provided at one end with the oil pump-room located in the storehouse.

The material racks and bins all run crosswise of the house with an aisle up the center; the door space is reserved in the center for receiving and shipping material.

The width, height, length and general dimensions will vary to suit the requirements.

### Oil and Storehouses.

**Oil Houses.** — Oil houses are necessary on railroads to store and handle the various oils required for engine, car, and shop service.

The most common arrangement consists of a frame or masonry shed with basement and platform, located alongside a track in convenient proximity to the various departments to be served.

Usually steel tanks are provided for storing the oil, varying in capacity from 500 to 2000 gallons or more; they are set up on concrete supports in the basement, so that they can be easily examined and cleaned.

When the supply is brought by barrels, they are dumped over fillers inside the house or outside on the platform if desired; when filled from car service tanks, the pipes are extended under the platform and provided with stop cocks and hose connections as per Fig. 268.

The floor over the basement is usually heavy plank not less than 3 in. thick, or reinforced concrete. A trap door and small ship ladder are necessary to gain access to the basement, the trap door and frame being made fireproof. No other openings are provided, electric light being used when desired for inspection purposes.

The tanks are generally ventilated by a pipe connecting each

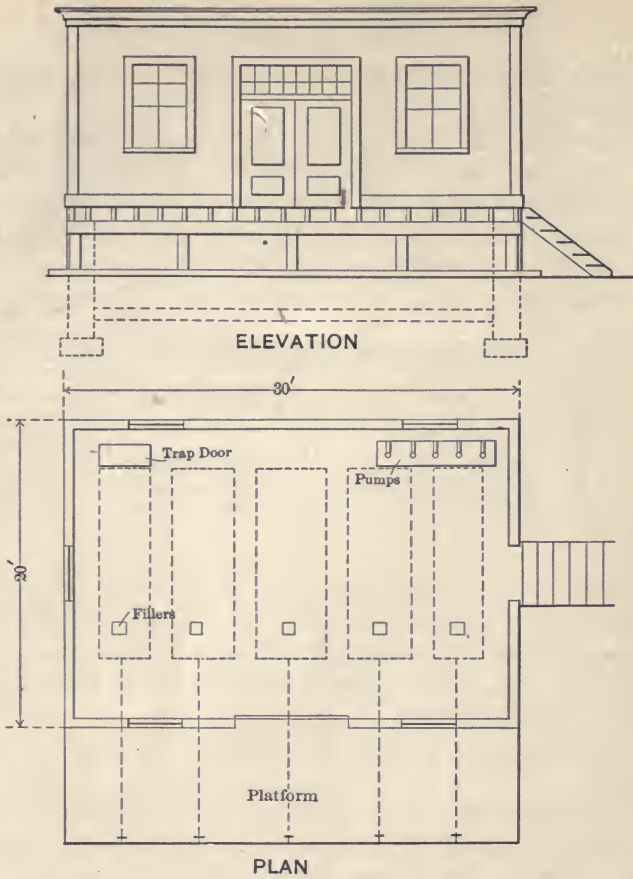

Fig. 268. Oil House.

tank, with a main riser taken above the roof, to allow escape of air and gases.

The floor above the basement is used for the distribution of oil to employees; each tank is connected to a hand or power pump; the pumps are grouped together and set up conveniently in one corner of the house with oil stands, trays, and drip pans, and a counter with waste bins and can racks is placed where most convenient.

APPROXIMATE COST OF OIL HOUSES COMPLETE. (Fig. 268.)

Size.	Concrete foundation and floor, wood platform.
30'×20'×12' high	\$1500 to \$1900
45'×20'×12' high	2500 to 2900
60'×21'×12' high	3000 to 3900

*Construction.* — The chief points to be considered in the construction are to eliminate the risk of fire, to provide ample storage and convenient means for filling the tanks either from barrels or oil cars, and to provide proper facilities for handling, pumping, and distribution.

Fig. 268 illustrates a 30' × 30' oil house with steel tanks in basement.

The foundation walls up to platform level, also basement floor, are of concrete; the oil house floor may be of reinforced concrete or heavy plank. The house frame is 2" × 6" studs at 2-ft. centers with rough boarding and shiplap with building paper between on the outside, and 1-in. sheathing on the inside. The roof is 2" × 8" joists at 2-ft. centers covered with 1-in. T. & G. boards and finished with tar and gravel.

The platform on the track side is supported on 8-in. diameter cedar posts on mud sills, with 2" × 10" joists at 24-in. centers covered with 3-in. plank.

The tanks are made of steel boiler plate with pipe connections and hand hole with valve for cleaning purposes, and have the following capacity:

Four feet 6 in. diameter,  $\frac{1}{4}$  in. thick metal, 12 ft. long, 1200 gal.

Four feet 3 in. diameter,  $\frac{1}{4}$  in. thick metal, 12 ft. long, 1000 gal.

Three feet 3 in. diameter,  $\frac{3}{8}$  in. thick metal, 12 ft. long, 600 gal.  
 Three feet diameter,  $\frac{3}{8}$  in. thick metal, 12 ft. long, 500 gal.  
*Approximate estimate of cost:* (Fig. 268.)

Quantities.	Material.	Labor.	Total unit.	Cost.
68 cubic yards excavation.....	.....	.....	\$0.50	\$34.00
53 cubic yards masonry.....	\$2.50	\$3.50	6.00	318.00
23 cubic yards concrete.....	3.00	3.50	6.50	149.00
7000 feet B. M. lumber, per thousand.....	18.00	17.00	35.00	245.00
Doors and windows.....	50.00	35.00	.....	85.00
5 squares roofing, per square (100 square feet)	2.50	2.50	5.00	25.00
Hardware and reinforcement.....	75.00	47.00	.....	122.00
Painting and glazing.....	25.00	30.00	.....	55.00
5 tanks, capacity 4100 gallons.....	280.00	296.00	.....	576.00
Pumps, piping, connections, and fittings....	100.00	63.00	.....	163.00
Steam coils.....	16.00	12.00	.....	28.00
				\$1800.00
Supervision and contingencies.....				180.00
Total.....				\$1980.00

or about \$3 per square foot or 16½¢ per cubic foot.

**Oil House, K. C. S. Ry., Pittsburg, Kan.** — Oil house, K. C. Southern Ry., Fig. 269, has a number of interesting features. It provides for the storage and distribution of oils and waste for the terminal at which it is situated only, and includes a basement that is built out to the platform edge of reinforced concrete; this portion is 59 ft. by about 38 ft., while the upper portion of the house is about 41½' × 14' wide. The platform is 4 ft. above base of rail and the floor of the basement 7 ft. below grade. A double incline paved with brick proves a convenient means of traffic between platform and basement. The approximate estimate cost of this building complete under ordinary conditions would be about \$6500. This includes the platforms and approaches as well as all interior fittings.

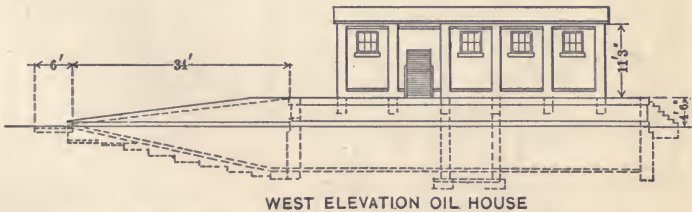

WEST ELEVATION OIL HOUSE  
 Fig. 269. K. City S. Ry., Pittsburg, Kan.

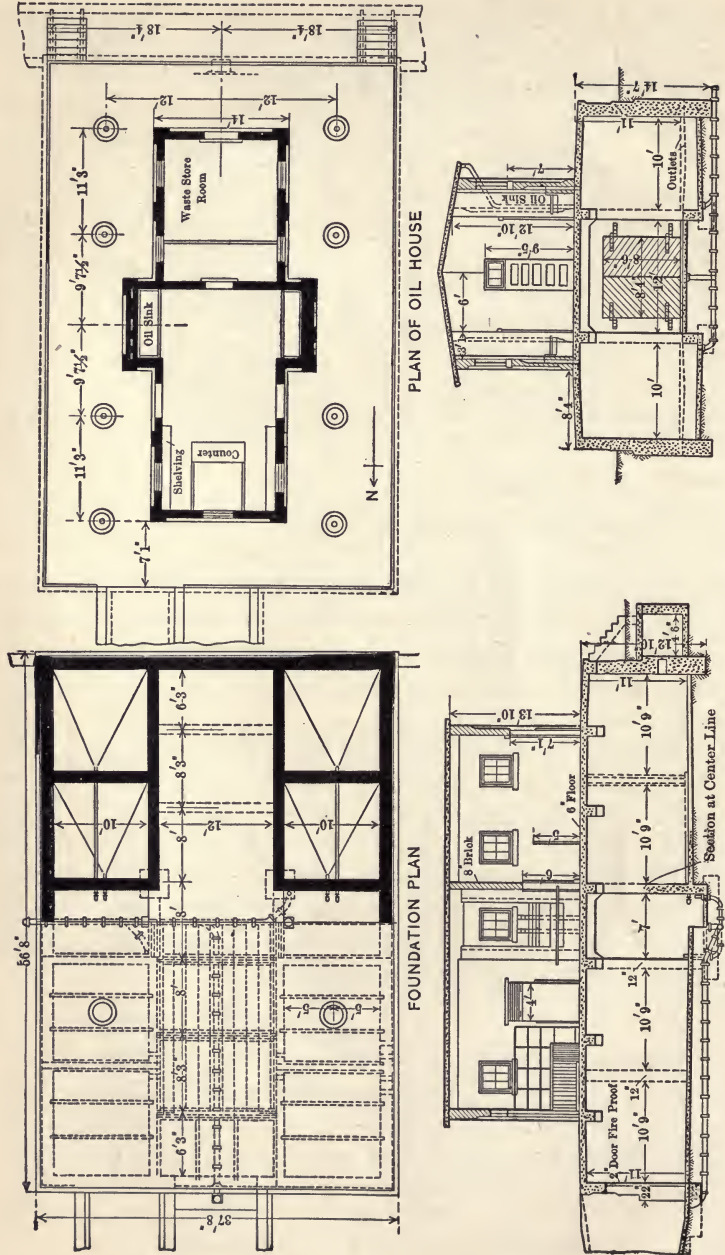

Fig. 269 (continued). Oil House, K. C. S. Ry., Pittsburg, Kan.





**Locomotive and Car Shops.** — The grouping of shops for the manufacture of cars and locomotives as well as their repair and maintenance has been given a great deal of attention and considerable study during the past few years by specialists in conjunction with railway engineers, and while the shops are common in regard to their use there cannot be said to be any typical plans that will suit all conditions; as a rule what serves the purpose at one point may be totally and entirely wrong at another place; varying conditions and a great variety of reasons require that each case be studied out and designed to meet the requirements desired and necessary to fit the situation.

The tendency in shop buildings has been to group and correlate each department; to centralize power, and to cut down traffic of men and material in operation, and to so arrange the layout as will best suit the conditions and locality in which the shops are situated.

In general it may be said that the layout usually arranges itself around the locomotive machine and erecting shop as this is the most important and largest building in the group.

A group of buildings of this character though built some years ago and considerably extended in 1913 is the C. P. R. Angus Shops at Montreal, Fig. 271, also the New York Central Shops, West Albany, N. Y., Fig. 272. In these layouts it may be mentioned that a transfer table is used for the handling of equipment and material supplemented with traveling cranes, but the tendency at the present time is to discard the transfer table and use electric cranes almost exclusively.

In Fig. 271 the buildings are grouped along a transverse avenue 80 ft. wide over which a 10-ton overhead traveling electric crane operates through a distance of about 1000 ft.

A brief description of the various shops and their approximate cost follows:

As already mentioned, the costs of the various structures are those which ruled during normal times, that is, previous to 1916. Since that date prices have increased considerably, and conditions are such that no definite figures of cost data can be established at the present time.

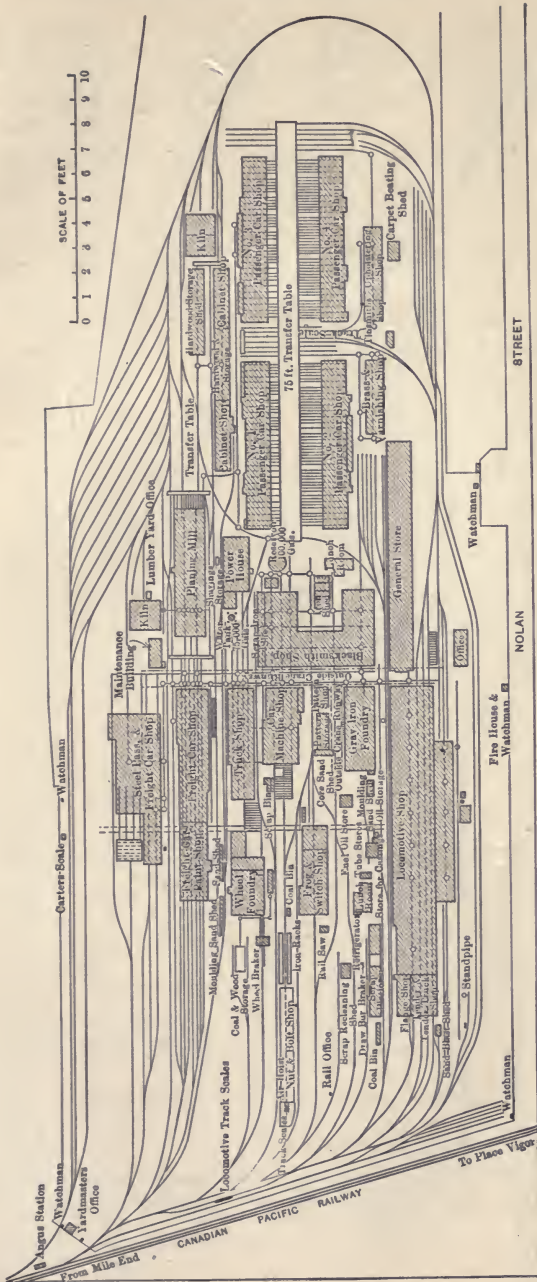

Fig. 271. General Layout, C. P. R. Angus Shops, Montreal, P. Q.

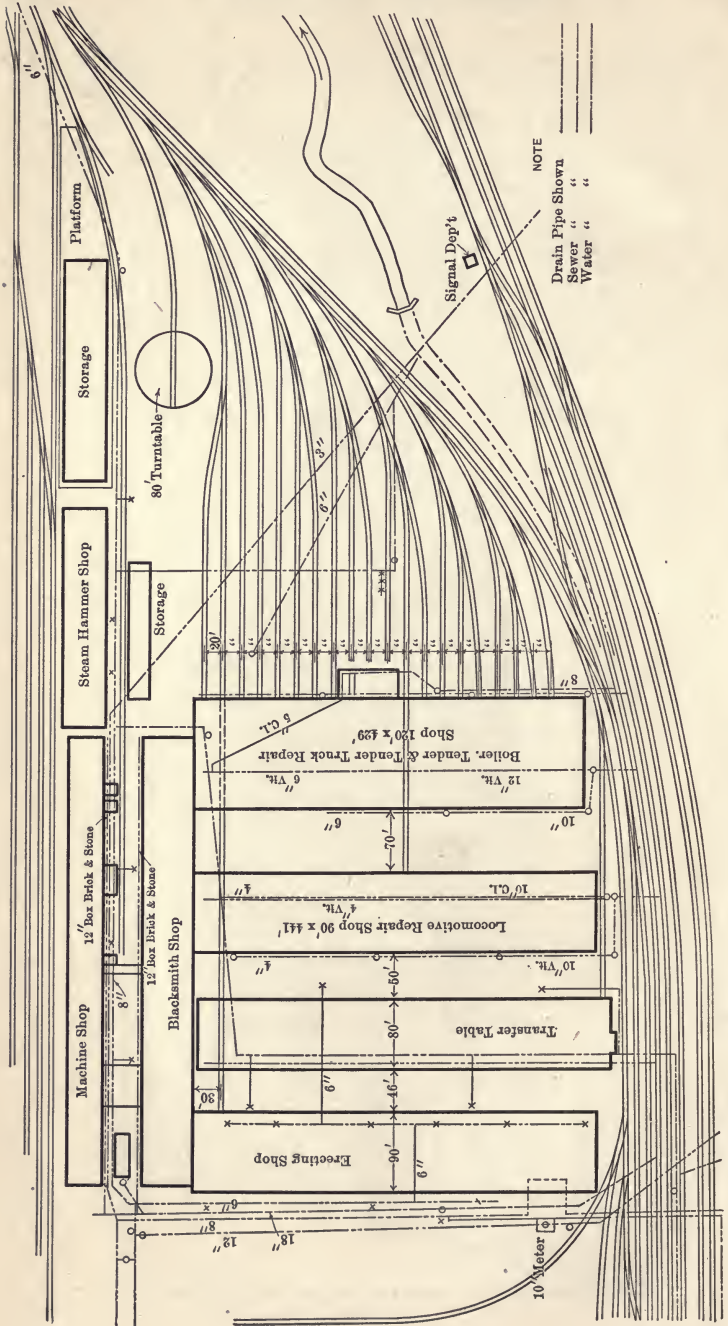

Fig. 272. General Layout, N. Y. Central Shop, West Albany, N. Y.

**Blacksmith Shop.** — Masonry foundations, brick walls with pressed brick facing, door and window sills stone, steel posts, trusses, and purlins, wood rafters covered with 3-in. plank and tar and gravel roof.

Skylights over the center running the full length of shop. Floor, 12 in. cinders. Lavatory and office accommodation inside shop, ground floor.

The building is L-shaped, with extreme dimensions 434'  $\times$  300', one wing being 146 ft. and the other 130 ft. wide.

The building is opposite the gray iron foundry and car machine shop, with the long side facing the midway. In the interior of the building the wings have "hip" roofs, and each divides into three equal aisles by row of columns supporting the roof trusses. The center aisle has a clerestory equal to the width of the trusses. The building covers an area of 83,600 sq. ft., and is equipped with tools and furnaces for working iron. The furnaces all use oil fuel, so that there is little smoke, and the ventilation is obtained by overhead pipes connected with large exhaust fans driven by electric motors. The larger hammers, punches, and shears are located in the small wing. There are three standard gauge tracks leading from the forge to the runway and overhead crane, and also three tracks leading from the smith shop. In addition there is a longitudinal track through the center of the long portion of the building.

**Cabinet and Upholstering Shop.** — Masonry foundations, brick walls with pressed brick facing, door and window sills stone, wood posts and rafters in cabinet shop and steel posts and beams in storage portion and upholstering floor, roof 3-in. plank with tar and gravel covering. Skylights 10 ft. wide running lengthwise over the center of the building, which is 62'  $\times$  500'. The cabinet shop occupies half the ground floor, the other half being set apart for hardwood storage; the portion above the hardwood storage forming a second floor is used for an upholstering room. The building is located convenient to the planing mill, the passenger car shop, and the dry kiln, and is equipped with hoists, stairs, and office accommodation inside, with a lavatory lean-to on outside of building. Ground floor, 3-in. plank on 4"  $\times$  6" sleepers 4-ft. centers on a 12-in. cinder bed; upper floor, 3-in. plank on wood joists.

**Car Machine Shop.** — Masonry foundations, brick walls with pressed brick facing and stone trimmings for door and window sills, steel posts, wood trusses and rafters covered with 3-in. plank and tar and gravel roof, skylights in each bay 12 ft. wide by 60 ft. long. Floor, 3-in. plank on 4" × 6" sleepers 4-ft. centers on a 12-in. cinder bed.

The shop is 288 by 130 ft. It has three lines of track running through it longitudinally. The cross section is divided into equal spans 43 ft. 4 in. by steel columns 24-ft. centers, which support the wooden roof trusses. A lean-to on one side of the building provides office, lavatory, and fan room accommodations.

**Car Truck Shop.** — Masonry foundations, brick walls with pressed brick facing, door and window sills stone, wood posts and rafters covered with 3-in. plank and tar and gravel roof. Floor, 3-in. plank on 4" × 6" sleepers 4-ft. centers on a 12-in. cinder bed. The shop is 82' × 434'. It is divided into three equal sections each 26 ft. 8 in. span at the western portion, where steel columns and supporting steel beams are used, while the eastern portion is entirely of wood construction and here there are four sections each 20-ft. span. The steel construction was used for the purpose of handling trucks from overhead supports.

On one side of the building there are two 16' × 24' fan houses and on the opposite side two 12' × 18' lavatories and toilet rooms.

**Dry Kilns** (soft and hard wood). Masonry foundations, brick walls outside, wood partitions inside, wood roof covered with tar and gravel.

The dry kiln has three compartments — one for soft wood, 19' × 85', one for hard wood, 19' × 85', and an additional 21' × 85' compartment for miscellaneous work. These are equipped with patent heating apparatus. There are no end walls, but the openings are covered by canvas doors operated by an overhead roll like a curtain.

**Foundry Iron.** — Masonry foundations, brick walls faced with pressed brick, window and door sills stone, steel posts, trusses, and purlins, wood rafters covered with 3-in. plank and tar and gravel roof. Skylight lengthwise along center of house. Floor,

3-in. plank on 4" × 6" sleepers and 12-in. cinder bed for the chipping and tumbler room, office, sand and facing room, 12 in. sand for the moulding floor, concrete for the blower room, and cinders and clay for the cupola room.

The iron foundry is 122' × 242', located near the locomotive shop, with one end facing the midway. The cross section of the building is in three sections, the central one having a height of 29' to the lower side of the roof truss, and it is served by a traveling crane of 57-ft. span and 10 tons capacity. The side wings are each 30 ft. wide and 16 ft. high. Over the cupola room there is a second story with a storage bin and a heavy platform, which serves as a charging floor. This is an extension to which the yard crane delivers pig iron and coke. This building covers an area of 42,700 sq. ft.

Data of electric traveling cranes are given in Table 132.

**Freight Car Shop.** — Masonry foundations, brick walls faced with pressed brick, door and window sills stone, steel posts 24-ft. centers, wood trusses and rafters covered with 3-in. plank and tar and gravel roof, skylight over each bay. Floor, 3-in. plank on 4" × 6" sleepers 4-ft. centers on a 12-in. cinder bed; every seventh bay has a brick fire curtain wall with communicating fire doors.

The shop is 107' × 540', and is served by a yard crane across one end and by four longitudinal tracks running through it. There are also two intermediate tracks for supplies and six traveling cranes fitted with air hoists for handling heavy material.

On one side of the building there are two 16' × 24' fan houses and one 12' × 41' lavatory and one 12' × 40' office in a one-story lean-to. The roof trusses are supported on steel columns, which carry 12-in. girders for three 1-ton traveling air hoists in each aisle of the building. The wall girders for the crane runways are carried on steel brackets bolted through the pilasters.

**Frog and Switch Shop.** — Masonry foundations, brick walls faced with pressed brick, window and door sills stone, steel columns and purlins, wood rafters covered with 3-in. plank and tar and gravel roof. Skylights along center of shop. Floor, 3-in. plank on 4" × 6" sleepers at 4-ft. centers and 12" cinder bed.

The shop is 102' × 264', has a single track extending through

it, and is also served by a 33-ft. 2-ton traveling crane in two of the three sections into which it is divided. Data of electric traveling cranes are given in Table 132.

**Locomotive, Erecting and Machine Shop.**—Masonry foundations, brick walls faced with pressed brick, door and window sills stone, steel posts and trusses, wood rafters covered with 3-in. plank and tar and gravel roof, with skylights and ventilators, 3-in. plank floor on 4" × 6" sleepers at 4-ft. centers on a 12-in. cinder bed.

The locomotives are handled by two 60-ton cranes of 77-ft. span, each with 10-ton auxiliary hoist.

In the machine shop there is one 15-ton crane of 77-ft. span, with a runway which is the extension of the erecting shop. All cranes driven by continuous-current motors at 250 volts.

The walls of the locomotive shop are 48 ft. high to the eaves; they are divided into panels 22 ft. wide by pilasters which carry the roof trusses. Each panel has two windows 12 ft. wide and 16 ft. high. In each roof panel there is a transverse monitor 12' × 72', with double pitched skylight roof, and in the sides 2' × 3' ventilating doors.

On the east side of the shop there are four 12' × 24' one-story extensions, which are used as lavatories. The balcony is used for a sheet-iron shop and for light machinery.

The boiler shop occupies 300 ft. of the south end of the building, is supplied with a 17-ft. gap hydraulic riveter, and above it the riveting tower, which occupies one panel of the 80-ft. bay, is 65 ft. from top of rail. There are two 25-ton hydraulic cranes.

The shop equipment is a hydraulic triple punch and a two-plunger flanger, four riveting furnaces and a flange furnace, hydraulic punch and shears, small hydraulic riveter, hydraulic pump, the machine tools served by cranes 50-ft. span, one 15-ton and the other 10.

The machines include a very long planer, a heavy 3-headed frame slotted machine and a driving wheel press and a milling machine for cylinders, a four-spindle frame drilling machine direct driven by four motors, and one electric oil pump, 3-spindle cylinder borer direct driven, 10-horsepower motor, a cylinder planer direct driven by electric motor, large driving wheel lathe.



Two 10-ton cranes for the outside runways, with one 25-horsepower and 8-horsepower direct-current 250-volt motors.

One 20-ton 77-ft. crane in the boiler section of the locomotive shop, and one 10-ton 50 ft. span crane in the iron foundry, and one 10-ton crane in the engine room of the power plant, and in addition a number of small cranes and air hoists in the other shops.

Data of electric traveling cranes are given in Table 132.

**Offices (Main).** — Masonry foundations, brick walls faced with pressed brick, door and window sills stone, wood floors and partitions, slate roof. Interior natural finish and plastered walls burlapped 6 ft. high in halls. Lavatory and toilet accommodations on each floor.

The building is 56' × 80', three stories high, with a basement and attic near the center of the building. The basement to be used for testing room, lavatory and heating apparatus, storage and small offices. The first floor is for clerks and storekeepers, the second for officials of rolling stock and car builders, and the third for drafting room and blue-print room.

**Passenger Car Shop (Erection and Paint).** — Masonry foundations, brick walls faced with pressed brick, door and window sills stone, wood posts, and rafters covered with 3-in. plank and tar and gravel roof, skylights in each bay, floor 3-in. plank of 4' × 6 sleepers at 4-ft. centers on a 12-in. cinder bed.

The passenger car erection and paint shops are each 100' × 672', and they are served by an electric transfer table 75 ft. long operated by a 20-horsepower alternating-current motor. Each shop has 28 tracks spaced 24 ft. center to center. On account of the peculiarity of track approach to the shop grounds, necessitated by the contour of the shop yard, the transfer pit is placed with longitudinal axis parallel to the long shops. In the passenger department the cars enter the transfer table by a long curve from the main shop track.

**Pattern Storage.** — Masonry foundation, brick walls with pressed brick facing, door and window sills stone, steel posts and rafters and reinforced concrete roof covered with tar and gravel, with skylights over roof. Intermediate wood posts support the floors.

Ground floor, concrete on a sand bed; first and second floors, heavy floor beams and  $4\frac{1}{4} \times 3\frac{1}{4}$  flooring with  $1\frac{1}{2}$ -in. air spaces.

The building is  $50' \times 100'$ , and is three stories. Inside light only is obtained from skylights in the roof. The four exterior doors are covered with galvanized iron.

**Pattern Shop.** — Masonry foundation, brick walls faced with pressed brick, window and door sills stone, wood posts, beams and rafters covered with 3-in. plank and tar and gravel roof. Ground floor, 3-in. plank on  $4 \times 6$  sleepers 4-ft. centers and 12-in. cinder bed. First floor, 2-in. T. & G. planks on  $6'' \times 12''$  joists about 4-ft. centers.

The pattern shop is  $50' \times 82'$ , two stories high, and is located on the midway opposite the blacksmith shop.

**Planing Mill.** — Masonry foundations, brick walls faced with pressed brick, window and door sills stone, steel posts, wood trusses and rafters covered with 3-in. plank and tar and gravel roof, with skylights over each bay.

Floor, 3-in. plank on  $4'' \times 6''$  sleepers 4-ft. centers on 12-in. cinder bed. The planing mill is  $126' \times 500'$ , similar in construction to the car machine shop, but has one row of columns which divides it into longitudinal aisles. There is a track passing through the center of each aisle and one transverse track with turntables at the intersection which connects with the dry kiln.

**Power House.** — Masonry foundation, brick walls faced with pressed brick, steel trusses, wood rafters covered with 3-in. plank and waterproof covering with a 2-in. air space and a covering of  $1\frac{1}{4}$  in. T. & G. boards on top finished with tar and gravel roof with skylights over. Boiler and pit duct room floors 6 in. concrete, engine room floor hardwood. A steel frame is placed around the smoke stack, leaving two feet clear on each side. The stack is also insulated by sheet steel and heavy asbestos board to guard against fire.

The house is located near the planing mill in order to use the refuse lumber and shavings. The building is  $101' \times 168'$ , divided by a longitudinal middle wall into boiler and engine room. The engine room is equipped with a 10-ton traveling crane.

Engine and generator equipments are as follows: Three 750 and one 375 horsepower cross compound horizontal Corliss en-

gines, making 150 revolutions per minute, direct connected to three 500-kilowatt and one 250-kilowatt, three-phase, 300-volt, alternating-current generators; two 250-kilowatt, 250-volt direct-current dynamos for the crane service, air compressors to supply air at 100 lb. pressure through one seven-inch and one two-inch main leading to the different shops.

In the boiler house there are four 416-horsepower boilers working under a pressure of 150 lb. and one 300-horsepower boiler at 300 lb. working pressure used in testing locomotives; boilers hand stoked, equipped with shaking grates.

There is a shaving exhaust system for supplying the boilers with the refuse from the planing mill. The induced system of draft is used on the boilers, and the stack is of steel 8 ft. in diameter and 70 ft. high. The induced draft is operated by two 10-ft. fans each making 200 revolutions per minute. Two economizers are used and are sufficient for the five boilers already installed. Further data of cost are given in Table 131.

The boiler connects with a 12-in. header, and there are reducing and by-pass valves provided to permit high-pressure steam to be used in the mains from the low-pressure battery.

There are two 12" × 7" × 12" and two 6" × 3½" × 6" feed pumps, also feed water heater. Underneath the boiler house is a tunnel terminating at an air hoist for lifting the ash cars to the surface track. The ashes are discharged to floor hoppers, from which they are emptied into the tunnel cars. The steam pipes are carried from the power house to the several buildings in a tunnel 6 ft. high, 4½ ft. wide, built of brick. Wall brackets carry the live steam pipes for heating by night and exhaust steam by day, a high-pressure steam pipe for locomotive tests, the compressed air pipes, and a return pipe for drainage of all the heating apparatus. The steam exhaust pipes are covered with asbestos air cell covering wired on. A few of the smaller mains are carried underground in wooden boxes. The distribution of electric power to the different shops is by bare wire on steel poles.

Data of miscellaneous power house equipment are given in Table 131 and electric traveling cranes in Table 132.

**Stores.** — Masonry foundations, brick walls faced with pressed brick, door and window sills stone, wood posts and rafters

covered with 3-in. plank and tar and gravel roof. Ground floor, 3-in. plank on 4" × 6" sleepers 4-ft. centers on a 12-in. cinder bed; second floor, 2-in. T. & G. plank on heavy joists.

The house is 85' × 594', and is located with one end facing the midway directly opposite the end of the large machine shop. This building is two stories high; it has wooden roof girders supported by three longitudinal rows of wooden columns, which carry a center gallery supported on joists between girders. The sills of the windows are 13½ ft. above the floor line to allow for storage racks and shelves on the walls below them. The gallery is lighted by 12-ft. standard monitors extending the whole length of the building.

Offices, scales, hoists, and lavatory and toilet accommodation are provided on the ground floor.

**Wheel Foundry.** — Masonry foundations, brick walls faced with pressed brick, door and window sills stone, steel posts, trusses, and purlins, wood rafters covered with 3-in. plank and tar and gravel roof; skylights in each bay; moulding floor, 12 in. cinders and clay.

The foundry is located on the extreme northwest portion of the yard and is convenient to the freight car and truck shops. It is 107' × 187', and is divided into three sections transversely, two of them 52 ft. 6 in. span. The cupola room, 27 ft. wide, is two stories, having a length of 90 ft., and the second floor is built like that on the iron foundry, having a charging floor on the opposite side. There is a one-story extension 12' × 27' for toilet room and lavatory. At each end of the building 40 ft. is used for the annealing pits, and this is served by a 3000-lb. crane, running transversely to the longitudinal axis of the building. This building covers an area of 24,300 sq. ft.

**Electric and Telephone Installation.** — There are about 200 electric motors used in the different shops, and only 15 of them are of the variable-speed type. All the machine tools, cranes, transfer table, heating and exhaust and the various draft fans are motor driven. The constant-speed motors are of three-phase induced type, using current at 550 volts.

In the buildings there is a mixed system of open porcelain cleats and slow-burning waterproof wire in the ceiling and Richmond conduits and rubber-covered wire on the side walls. Cut-

out boxes are supplied for about every 100 horsepower of motor wire and every 10 kilowatts of lighting. The shops and yards are lighted with four hundred 110-volt enclosed arc lamps and in addition 3800 16-candlepower incandescent 110-volt lamps.

In the passenger car shops low extension arc lamps are installed.

In the yard there are 50 enclosed series arc lamps.

There is a complete telephone system using fixed telephones connecting to long-distance wires.

This system is equipped with metallic circuit, electric generators for ringing, and self-restoring drops.

TABLE 130. — APPROXIMATE COST DATA RAILROAD SHOPS, FOUNDATIONS 5 FEET BELOW GROUND.

Shop name.	Average width, length, and height.	Contents.		Cost of building only.			Equipment add per cent of total cost.*
				Total.	Sq. ft.	Cu. ft.	
	Ft.	Sq. ft.	Cu. ft.			Cents.	Per cent.
Blacksmith.....	146×434 and 130×158×32	83,600	2,697,000	\$101,000	\$1.20	3½	30
Cabinet.....	62×580×27	36,900	954,700	53,000	1.43	5½	25
Car machine.....	130×288×27	38,400	1,066,600	44,200	1.15	4½	25
Car truck.....	82×434×20	36,800	763,600	38,600	1.05	5	20
Dry kiln, soft wood.....	70× 85×16	6,900	96,500	7,400	1.05	7½	90
Dry kiln, hard wood.....	40× 85×16	3,700	51,700	4,200	1.11	8	90
Foundry, gray iron.....	122×342×30	42,700	1,354,700	80,300	1.90	6	40
Freight car.....	107×540×30	59,500	1,829,900	76,700	1.28	4½	25
Frog and switch.....	102×264×22	30,300	674,000	29,700	0.99	4½	30
Locomotive, boiler, erecting and machine.....	163×168×50	191,300	9,520,800	497,200	2.60	5½	10
Offices.....	56× 80×54	4,500	241,900	27,700	6.20	12	35
Passenger car erection.....	100×672×24	69,400	1,752,700	69,000	1.00	3½	35
Passenger car paint.....	100×672×24	69,400	1,752,700	75,800	1.07	4½	35
Pattern.....	50× 82×26	4,100	135,500	7,400	1.80	5½	25
Pattern stores.....	50×150×30	7,500	247,500	17,300	2.31	7½	5
Planing mill.....	50×150×30	63,300	1,835,300	64,400	1.33	4	30
Power house.....	104×160×39½	17,200	616,400	84,700	4.92	1½	500
Stores general.....	85×594×33	50,500	1,653,500	88,100	1.75	5½	20
Wheel foundry.....	107×187×24	24,300	649,800	46,700	1.93	7½	100

\* Equipment includes heating, plumbing, fire protection, cranes, elevators, electric wires and lighting.

The foregoing prices are for shops built previous to 1915; since that date, owing to abnormal conditions, the prices have increased from 50 to 75 per cent. This refers also to the cost data given in Tables 131, 132 and 133.

TABLE 131. — DATA OF MISCELLANEOUS POWER HOUSE EQUIPMENT.

Equipment.	Approximate cost in place.	Approximate cost per unit.
Boilers and stokers.....	83,500	\$27.50 per B. H. P.
Generators.....	50,600	22.48 per Kw.
Engines.....	68,000	20.88 per H.P.
Compressors.....	15,400	
Economizers.....	10,500	
Induced draft.....	11,500	
Ash-handling apparatus.....	1,500	
Piping.....	27,000	
Switchboard.....	28,000	
Feed pumps.....	2,500	
Shaving feed and storage.....	8,800	
Total.....	\$312,300	

Rated H.P. boilers, 3219; engines, 3265; Kw., 2250.

TABLE 132. — SHOP ELECTRIC TRAVELING CRANES.

Shop location.	Number.	Capacity.				Motors H.P. D.C. 250 volts.				Speeds in ft. per minute loaded.				Crane clearance.	Approximate cost erected.
		Main tons.	Aux'y tons.	Span.	Lift hook.	Drum hoist.	Trolley.	Bridge.	Aux'y.	Main.	Trolley.	Bridge.	Aux'y.		
Erecting.....	2	60	10	76½	25½	50	7½	50	27	10	100	250	25	24½	29,200
Machine.....	1	15	.....	52	25½	27	3½	27	.....	19	125	300	.....	25½	5,800
Machine.....	1	10	.....	52	25½	27	3	27	.....	27	150	300	.....	25½	5,300
Boiler.....	1	20	5	76½	25½	25	5	25	10	12	100	250	20	.....	9,500
Midway.....	1	10	.....	77	30	25	3	25	.....	25	125	250	.....	.....	5,100
Foundry.....	1	10	.....	60	30	25	2	25	.....	25	100	350	.....	.....	5,000
Foundry.....	1	10	.....	60	22	25	2	25	.....	25	100	350	.....	.....	5,200
Foundry.....	1	10	.....	30	12	5	.....	5	.....	16	.....	200	.....	.....	2,500
Frog.....	1	2	.....	30	20	3	.....	3	.....	10	.....	200	.....	.....	2,000

TABLE 133. — ORDINARY YARD LIFT STEAM CRANES WITH BOILERS.

Capacity.	Radius.	Approximate cost erected.
Tons.		
1½	25	\$2000 to \$2500
2	20	1800 to 3000
2	25	2500 to 3500

TRANSFER TABLE 75 tons capacity, 75 feet long, complete with 550-volt motor A.C., travel 125 feet per minute loaded, 300 feet per minute light (cable ½ inch), \$5500 to \$6500 erected, without foundations.



	PAGE		PAGE
Cost of — <i>continued</i>		Estimating prices — <i>continued</i>	
rail.....	188	for buildings.....	24, 25, 26
rail anchors.....	197	pile and frame trestles....	128, 129
railroads.....	40	pipe culverts.....	137, 140
railroad shops.....	573	spikes.....	199
retaining walls.....	95	switches.....	215
roads and streets.....	59	track work and material....	12
sheds, freight.....	366	weight, steel trestles.....	30
steam pumps.....	452	Electric light standards.....	324
steel spans.....	103	Electric motor trucks.....	385
steel viaduct.....	164	Elevated structure.....	163
storehouses.....	555	Elevation posts.....	306
street bridges.....	109	Engine houses.....	495
subways.....	33, 78	Equating track values.....	257
switches.....	215	Equipment rental.....	51
switch ties.....	17, 228	Excavation, cost of.....	55
tie plugs.....	253		
ties.....	174	F	
tie tamping.....	252	Farm crossing gates.....	267
track.....	14	Farm crossings.....	286
track scales.....	394	Feet —	
train service.....	50	of rail into tons.....	6
treating ties.....	182	in decimals of a mile.....	8
trestles.....	128	Fences —	
tunnels.....	71	open.....	276
turnouts.....	16, 211	portable.....	276
turntables.....	545	snow.....	275
water tanks.....	444	wire.....	263
wooden bridges.....	116	Fill, cost of.....	55
Crib abutments.....	101	Flagman's cabin.....	294
Culverts.....	137	Frame stations.....	317
		Frame trestles.....	126, 129
D		Freight scales.....	386
Dams.....	469	Freight sheds.....	361
Dead load, railway.....	105	Freight yard cranes.....	390
Deck and thro trusses.....	104	Frogs.....	219
Deck plate girders.....	102	Fuel stations.....	472
Derails.....	230		
Diamonds.....	235	G	
Drain, tile.....	49, 255	Gates, farm crossing.....	267
Draw bridges.....	104, 106	Grade separation.....	52
		Grading.....	47
E		Gravel ballast sections.....	243
Estimating prices —		Gravity retaining walls.....	35
concrete culverts, 152, 153, 154, 155,		Guards, bridge and trestle....	108
157, 158, 159, 160, 161, 162			



	PAGE		PAGE
<b>H</b>			
Half deck girders.....	102	Outbound sheds.....	364
Haul.....	47	Overhead farm crossings.....	287
Highway bridges.....	34, 109	<b>P</b>	
Highway crossing alarm.....	290	Passenger —	
Holding power of spikes.....	203, 204	platforms.....	334, 376
Houses —		stations.....	311
bunk.....	352	Paving.....	381
freight.....	361	Picket fence.....	277
ice.....	396	Pile trestles.....	126, 128
pump.....	465	Piling.....	48
rest.....	350	Pipe culvert.....	49
scale.....	395	Platform shelters.....	336
section.....	343	Platforms, freight.....	376, 381
station.....	311	Point switches.....	216
tool.....	339	Portable scales.....	385
Howe trusses.....	121	Properties of frogs.....	220
<b>I</b>			
Ice houses.....	396	Properties of rail.....	4
Inbound sheds.....	362	Public road crossings.....	288
Inspection pits.....	528	Pumps.....	449
Interlockers.....	236	<b>R</b>	
Interlocking towers.....	237	Rail.....	184, 251
<b>L</b>			
Loading platforms.....	383	Rail anchors.....	196
Locomotive and car shops.....	562	Rail concrete culverts.....	145
Log cribs.....	100	Rail, feet into tons.....	6
Log station.....	314	Rail joints.....	190
Life —		Rail joints and bolts.....	10
of frogs.....	224	Rail loading and unloading....	250
of ties.....	175	Rail properties.....	4
Live loads, railway.....	104	Rail rack posts.....	306
<b>M</b>			
Manganese frogs.....	225	Rail renewals.....	21
Mechanical coal stations.....	478	Rail, tons into track miles....	7
Mile board.....	302	Railway bridges.....	29, 102
Motor and hand cars.....	259	Railway crossing signs.....	302
<b>O</b>			
Oil and storehouse.....	556	Reballasting.....	247
Open viaducts.....	163	Reinforced concrete culverts...	150
Ordinates of curves, bridge....	107	Rental for equipment.....	51, 61
		Rest houses.....	350
		Retaining walls —	
		gravity.....	35, 58, 95
		reinforced.....	36
		Right of way fences.....	263
		Roadway, widths of.....	46

PAGE	T	PAGE
S		
Safety crossing gates.....	291	
Sand fences.....	275	
Sand towers.....	481, 491	
Scales, freight.....	385, 386	
Scales, track.....	391	
Screw spikes.....	200	
Section forces.....	261	
Section houses.....	343	
Section post sign.....	301	
Sheds, freight.....	361	
Shelters.....	321, 336	
Shops, railroad.....	562	
Signs.....	286	
Smoke jacks.....	509	
Snow fences.....	275	
Snowplow and flanger signs....	300	
Snow sheds.....	275	
Spikes.....	198	
Stand, switch.....	217	
Standpipes.....	461	
Station buildings.....	311	
Station canopies.....	335	
Station mile board.....	303	
Steam shovelwork.....	56	
Steel bumping post.....	234	
Steel tanks.....	446	
Steel ties.....	182	
Stock yards.....	419	
Stone ballast.....	246	
Stone box culverts.....	144	
Stop and slow post signs.....	300	
Store and oil houses.....	556	
Storehouses.....	553	
Street grades.....	58	
Subways.....	76	
Subways, weight of steel.....	34	
Surfacing.....	250	
Switches.....	215	
Switch leads.....	213	
Switch ties —		
for crossovers.....	23	
for turnouts.....	22	
Switch ties, common.....	171	
Tables: Rail Dimensions and Properties.....	4	
boring tools.....	38, 39	
building live and dead loads..	27, 28	
cost of rail and arch culverts	37	
crossovers.....	17	
elements wooden beams.....	32	
estimating prices, track work	12	
estimating prices for build- ings.....	26	
feet in decimals of a mile....	8	
feet of rail into tons.....	6	
quantities, bridge abutments	84	
bridge piers.....	86	
quantities, gravity retaining walls.....	35	
quantities, reinforced retain- ing walls.....	36	
rail joints and bolts.....	10	
structural material and esti- mates.....	24, 25	
switch ties for turnouts.....	22	
tons of rail into track miles..	7	
track material per 100 feet..	20	
track material per mile.....	20	
turnout quantities.....	16, 18	
weight, steel work on subways	33	
steel, highway bridges.....	34	
weights, railway bridges.....	29	
steel trestles.....	30	
wooden trestles.....	31	
Tanks, water.....	436	
Throwing track.....	252	
Tie plates.....	205	
Tie plugs.....	253	
Ties.....	171, 172	
Tie tamping.....	252	
Tile drains.....	255	
Tile pipe culvert.....	138	
Tons of rail into track miles...	7	
Tool equipment.....	258	
Tool houses.....	339	
Tower —		
crossing.....	295	

	PAGE		PAGE
Tower — <i>continued</i>		U	
interlocking.....	236	Unit prices.....	45
Track, cost above subgrade....	14	V	
Track material and estimates..	18	Valuation cost of railways.....	42
Track material per 100 feet and		Viaducts, retaining walls.....	167
per mile.....	20	W	
Track depression.....	54, 55, 57	Wagon scales.....	388
Track elevation.....	54, 57	Watchman's cabin.....	294, 360
Tracklaying.....	49, 250	Water stations.....	426
Track scales.....	391	Water tanks.....	436
Track signs.....	297	Weeding track.....	254
Track spikes.....	202	Weight —	
Track tanks.....	425	of steel railway bridges.....	29
Track work and material prices	12, 18	of steel subways.....	33
Train service.....	50	Whistle post.....	202
Train sheds.....	326	Wood cattle guards.....	271
Transfer, platform.....	368	Wood snow fences.....	275
Treated ties.....	179	Wooden —	
Trestle number.....	305	trestles.....	31
Trestles, steel.....	30	beams, elements.....	32
Trestles, wood.....	31, 126	Wooden bridges.....	121
Trespass sign.....	305	Y	
Trucking, cross.....	367	Yard cranes.....	389
Tunnels.....	62	Yard stock.....	421
Turnouts.....	16, 208		
Turntables.....	539		

— 1  
234771

