









# Railway AND Locomotive Engineering

A Practical Journal of Motive Power, Rolling Stock and Appliances

## INDEX FOR VOLUME XXIX, 1916

Illustrated Articles marked \*

### A

#### Air Brake Articles:

Air Brake, Requirements of an, 184.  
\*Air Compressors, Cost of Operating, 382.  
Air Pipes, Wrongly Connected, 225.  
Air Pump Bushings, Reboring 225.  
Air Pump, Care of the, 275.  
\*Air Pump Governor, Repairing, 299.  
Air Pump Heads, Repairing, 158.  
\*Air Pump Strainer, 115.  
Application of Distributing Valve, Retarded, 310.  
Back-up Hose, Stopping Trains with, 233.  
Brake Application, Variations in, 14.  
Brake Cylinders, Pressure in 224.  
Brake Engineering and Practice, Developments in, 172.  
Brake Operation, Installation Phase of, 7.  
Brake Freezing Up, 15.  
Brake Pipe Broken, 266.  
Brake Sticking, 225.  
Brake Valve Exhaust Port, Size of, 266.  
\*Brake Valve Manipulation, 57.  
\*Braking Power in Cars, Difference in, 390.  
Braking Ratio for Passenger Cars, Proposed, 42.  
\*B-3-A Conductor's Valve, The, 343.  
Car Brake Cylinder Arrangement, Passenger, 87.  
Charging Freight Train, Trouble in, 158.  
\*Compressors, Repairing Air, 169.  
Compressor Troubles, Cross Compound, 224.  
Dead Engine, Hauling, 301.  
Defect of Universal Valve, 123.  
\*Difference of Force of Impact Between Cars, 260.  
Defective Brake Valve, 123.  
Distributing Valve, Defective, 301.  
Distributing Valve, Defects of, 15.  
\*Distributing Valve, Repairs on, 337.  
Distributing Valve Works in Quick Action, 86.  
\*Electric Operation of New York P. S. Brake Equipment, 308.  
\*Empty and Load Brake, Advantages of, 296.  
\*Empty and Load Brake in Grade Service, 370.  
Equalizing Piston, Collapsible Type of, 310.  
E. T. Brake, Defective, 14.  
\*E. T. Equipment, Charging Trains with, 23.  
Exhaust Port, Leak at, 225.  
Federal Regulations, Changes in, 26.  
Freight Brake Conditions, 214.  
\*Governor Synchronizing System, 56.  
Handling Brakes on Yard and Passenger Service, 92.  
Improved Features in Brake Equipment, 266.  
Instructions to Yard Shifting Crews, 128.  
Limits of Brake Valve Gear, 267.  
Locomotive and Tender Brakes, Daily Inspection of, 94.  
L Triple Valve, Graduated Release of, 87.  
\*Parasite Reservoir Governor, 345.  
Passenger Car Brake Design, 114, 150.  
Passenger Car Brakes, Improvements in, 418.  
Passenger Train Braking, 229.  
\*P. S. Pneumatic Brake, 229.  
\*P. S. Pneumatic Brake, Operation of, 272.  
Pump Governor Trouble, 159.  
Quick Action, Causes for, 87.  
Quick Action, Undesired, 87.  
Recharge of Passenger Car Brakes, 159.  
Reducing Valve, Defective, 15.  
Repairing Triple Valves, 129.  
\*Single Shoe or Double Shoe Foundation Brake Gear, 77.  
\*Slid Flat Wheels, 336.  
\*Stop Distances, Calculating Train, 343.  
Strainer, Special "Fifty-four" Air Compressor, 274.  
Test Truck, the Portable Brake, 383.  
Train Stops, Improving, 309.  
Triple Valve, Defective Type L, 159, 301.  
Triple Valve Maintenance, 381.  
Triple Valve Piston, Fit of, 87.  
Triple Valves, Cleaning and Lubrication of, 402.  
\*Type J Compressor Governors, 25.  
\*Universal Control Equipment, 416.  
Universal Valves, Improvements in, 267.  
Universal Valve Operation, 15.  
Accidents, Serious, 306.

Adhesion, Factor of, 14.  
Alaska, Conditions in, 404.  
Alloys, Effect of Steel on, 311.  
American Boiler Manufacturers' Association, 284.  
Armor Plate, 235.  
Appliances, Reinventing Useful, 306.  
Apprentices, Co-operation, 52.  
Apprentices, Past and Present, 176.  
\*Apprentice Schools, Modern, 372.  
\*Apprentice School on the Erie, Another, 31.  
Apprentices, The Selection of, 10.

### B

Babbitt Metal, 225.  
Baltimore and Ohio, Railway Pay on, 178.  
Bells, 159.  
Belts, About, 267.  
Belt Stretching, 191.  
Blows and More Blows, 116.  
Boilers and Their Accessories, Testing, 158.  
Boiler Circulation, 91.  
Boiler Code, Hearing on the, 428.  
Boilers, Designs of, 53.  
Boilers, Design and Maintenance of, 221.  
Boilers, Effect of Soot in, 366.  
Boiler Inspection, 341.  
Boilers, Intelligent Care of, 268.  
Boilers, Strength and Weakness of, 53.  
\*Boiler Washing, Approved Method of, 190.  
Boilers, Washing of Locomotive, 65.  
Boilers, Water Circulation in, 264.  
Books, Buying, 228.

#### Book Reviews:

Air Brake Association Proceedings, 1916, 359.  
Accident Bulletin, 70.  
Automobile Repairing, 70.  
Bridge Foundations, 70.  
Chart of Steel Gondola Hopper Car, 431.  
Coal, 143.  
Electric Motors Direct and Alternating, 323.  
Electrical Tables and Engineering Data, 323.  
How to Build Up Furnace Efficiency, 323.  
Industrial Organization and Management, 285.  
Laboratory Tests of a Consolidation Locomotive, 35.  
Locomotive Dictionary, 162.  
Locomotive Management, 359.  
Locomotive Superheaters, 286.  
Lubricating Engineers' Handbook, 431.  
Maintenance of Way and Structures, 35.  
Mechanical Engineers' Handbook, 242.  
Mechanical Engineers' Pocket Book, 70.  
Oil Fuel Equipment for Locomotives, 209.  
Pamphlet on the Electro-Pneumatic Brake, 106.  
Passenger Terminals and Trains, 431.  
Practical Track Management, 359.  
Principles of Locomotive Operation and Train Control, 35.  
Proceedings of the American Railway Master Mechanics' Association, 105.  
Proceedings of the Master Boiler Makers' Association, 323.  
Proceedings of the Master Car Builders' Association, 105.  
Proceedings of the Traveling Engineers, 70.  
Rail Joints and Bonds, 143.  
Railway Organization and Management, 394.  
Rise of Rail Power in War and Conquest, 209.  
Smithsonian Institute Report, 285.  
Statistics of Common Carriers, 162.  
Time Card and Rule Examination, 242.  
Boxes, Preventing Hot, 376.  
Brain Power, 90.  
\*Brake Shoe and Brake Beam Equipment, 216.  
\*Brick Arch, Advantages of, 119.  
Bridges, Duration of Steel, 38.  
\*Bridge, Fall of the Quebec, 325, 340.  
\*Bridge, Hell Gate, 5.  
\*Bridge, Jacking the Quebec, 363.  
Bridge, The Quebec, 38.

### C

\*Canadian Northern, Through Service on, 37.  
\*Canadian Pacific, Improvements on, 73.  
Canadian Railway Development, 206.  
Car Construction, 134.

\*Car Ferry "Ramon," 327.  
Car, Power to Move or Step a, 86.  
Cars, Overworking Passenger, 269.  
Carbonized Oil, Removing, 158.  
Carbic Flare Light, The, 366.  
\*Cars, Automobile for Wheeling and Lake Erie, 235.  
\*Cars, Baggage for the Intercolonial Railway, 406.  
\*Cars for the Erie, Hopper, 234.  
Cars, Ventilation of, 413.  
Car Wheels, 216.  
Case Hardening, 51.  
Chemistry, The Mechanics' Debt to, 17.  
\*Chicago Great Western, Rebuilding the, 289.  
Coal for Locomotives, Pulverized, 328.  
Coal, Origin of, 153.  
Coal Pier on the Pennsylvania, New, 51.  
Coal, Powdered Paper Used Instead of, 415.  
Coal Reserves in the United States, 26.  
Coal, Saving and Waste of, 264.  
Coal, Simple Test of, 101.  
Coal, Text of, 413.  
Combustion, Spontaneous, 104.  
Committees, Mechanical Association Executive, 283.  
Common Things, Doers of, 307.  
Compressed Air in Shops, Use of, 98.  
Congress and the Railways, 377.  
\*Connector, The Robinson Steam Air and Whistle, 405.  
Convention, Air Brake, 130, 195.  
Convention, Fuel Association, 206.  
\*Convention, General Foremen's, 332.  
\*Convention, Master Car Builders, 216.  
\*Convention, Master Mechanics', 220.  
Convention of the National Machine Tool Builders, 385.  
\*Convention of Traveling Engineers, 356, 407, 412.  
\*Cranes for Railway Use, Locomotive, 361.  
\*Crosshead Shoes, Adjustable, 420.  
Cuban Railroads, Nationalization of, 178.  
Cylinder Condensation, 160.  
Cylinders, Location of Locomotive, 86.

### D

Difficulties, Keeping Out of, 239.  
\*Dining Cars, New Style of Decorating, 223.  
Dispatching, The Telephone System of, 63.  
Doctor of Engineering, Angus Sinclair as, 281.  
Draft Gear, 217.  
\*Drifting Device, Wyman's Automatic, 262, 403.  
\*Drifting and Relief Valve, Combined, 185.  
Drill Press, About the, 19.  
\*Drill Press Clamp, Pneumatically Operated, 81.  
\*Driving Boxes, Refitting, 79.

### E

Efficiency, 55, 193.  
Eight-hour Day, The, 153, 187.  
Eight Hours a Day, 304.  
Eight-hour Law, The Proposed, 340.  
Electrical Department:  
\*Arc Welding, Electric, 389, 414.  
\*Catechism of the Electric Locomotive, 201, 236, 278, 316, 347, 386, 421.  
\*Electric Drive on a Swing Bridge, 43.  
\*Electric Limit, The, 346.  
\*Electric Locomotive, Why the Crews Like the, 297.  
\*Electric Passenger Locomotive, 96.  
Electric Power Development, 63.  
\*Electric Railway, Pacific Coast, 137.  
\*Electric Rolling Stock, Design of, 221.  
Electricity's Dangers, 305.  
Electrification of Terminals, Chicago, 16.  
Electrification of the New York Central, 157.  
Electrification in England, 373.  
\*Electro-Pneumatic Brake System, Goff's, 199.  
\*Electro-Magnet System, Advantages of the, 386.  
General Electric's Exhibit, 137.  
Headlights, Incandescent, 137.  
\*Inductor Motor, 203.  
Locomotive, The Electric, 173.  
Locomotives, Electric on the Norfolk & Western, 136.

# INDEX FOR VOL. XXIX

\*Logan Division of the Ogden, Logan and Idaho Railway Equipped with Electric Power, 28.  
 \*Railway Electrification, Advance in, 211.  
 Rotary Convertors, Improvement in, 29.  
 \*St. Clair Tunnel, Electrification of, 96.  
 Storage Batteries on the New York Central, 137.  
 Trolley Shoe, New, 237.  
 \*Trolley Truck, Electric-Driven, 173.  
 \*Turbine-Generator, The Curtis, 62.  
 Units, Generating, 29.  
 Volt Ammeters, 172.  
 Emery Wheels, Grinding on, 99.  
 \*Engine Cleaners, Women, 290.  
 Engineer, Praise for, the, 49.  
 Engineer, The Tinkering, 168.  
 Engineers, Abuse of, 10.  
 Enginemem, Progressive, 88.  
 Enginemem, Superstitions of, 112.  
 Enterprising Drummers, 193.  
 \*Eric Flyer, Another Old Time, 83.  
 Eric Officials, Meeting of, 101.  
 Etching Machinist's Tools, 152.  
 Exactness in Doing Work, 125.  
 Explosions in Mines, 22.

## F

Farmers and Railway Men, 149.  
 Fatalities on Railroad Crossings, 377.  
 Feed Water, Doctoring, 98.  
 Feed Water for Locomotives, Selecting, 369.  
 Feed Water, Softening, 52.  
 \*Fenders, Anti-Collision, 95.  
 Figures Lie, Making, 226.  
 Finland, Railways in, 149.  
 Firemen Make Best Engineers, 192.  
 Firemen, Training of, 227.  
 Firing, Question of, 322.  
 Fitness, Natural, 127.  
 Flue, Burst, 14.  
 Flue Welding, Progress in, 9.  
 Flues, Leaky in Oil Burning Locomotives, 86.  
 Flues, Removal and Application of, 45.  
 Flues, Welding, 301.  
 Forge, The Catalan, 99.  
 Freight Cars, Construction, Maintenance and Abuse of, 84.  
 \*Freight Cars, Excellent Record of, 375.  
 \*Freight Cars, Standard Lettering of, 85.  
 Freight Cars, Their Construction, Maintenance and Abuse, 61.  
 Fuel Economy and Smoke Prevention, 220.  
 Fuel for Locomotives, Pulverized, 125.  
 Fuel Tests on a Locomotive, 404.  
 \*Furnace, Gaines Locomotive, 380.

## G

Gear, Power Reverse on Yard Engines, 340.  
 \*Gondola Car for the Pennsylvania, 189.  
 Grade Crossings, Safety on, 333.  
 Grades, Relation of, to Locomotives, 152.  
 Graphite, 123.  
 Graphite as a Lubricant, 151.  
 Graphite in Valve Chambers, 187.  
 \*Grease Cup, Improved, 152.  
 Grinding Appliances, Growth of, 40.  
 "Gripwell," Results from, 349.  
 Gun Metal, 178.

## H

Hammers, Soft Metal, 265.  
 \*Hand Brake, Improved High Power, 339.  
 Hardening and Tempering, 265.  
 Headlight in Order, To Put a, 374.  
 Heat and Steam, Facts Concerning, 55.  
 Heat Appliances, Wasteful, 199.  
 Heat, Laws and Relation of, 306.  
 Heat, Locomotive Not Wasteful of, 270.  
 Heat, Motion and Work, Measurement of, 313.  
 Heat Phenomena, 353.  
 Heat, Superficial Efforts of, 160.  
 Heat, Use and Waste of, 14.  
 \*Hoosac Tunnel Electric Locomotives, 328.

## I

Inch, Settling the Size of, 91.  
 Income and Uses, Improved Railroad, 342.  
 Industry, Power of, 18.  
 Injector, Defective, 266.  
 Injector, Failure, A, 227.  
 Interchangeability, 226.  
 Interchangeable Parts, Favors Greater Use of, 90.  
 International Railway General Foremen's Association, 284.  
 Inventors, Sponging, 194.  
 Iron and Steel Pipe, Wrought, 22.  
 Iron, Original Discovery of, 319.

## J

Job or Position, 18.

## L

### Locomotives:

\*American Locomotive Co., Pacific, 4-6-2 for the Delaware, Lackawanna & Western, 20.  
 \*American Locomotive Co., 2-10-2 for the Erie, 147.  
 \*American Locomotive Co., 2-10-2 for the New York, Ontario and Western, 146.

\*Baldwin Consolidation, 2-8-0 for the Lake Superior & Ishpeming Railway, 188.  
 \*Baldwin Mikado, 2-8-2 Type for the Raritan River Railway, 164.  
 \*Baldwin Mikado, 2-8-2 Type for the Chicago Great Western, 229.  
 \*Baldwin Mikado, 2-8-2 Type for the Lehigh & Hudson River Railway, 164.  
 \*Baldwin Mikado, 2-8-2 for the Missouri, Oklahoma and Gulf Railway, 11.  
 \*Baldwin Santa Fe, 2-10-2 Type for the Erie, 329.  
 \*Baldwin Santa Fe, 2-10-2 Type for the Bessemer & Lake Erie, 399.  
 \*Baldwin Four-coupled Switcher for Worth Brothers, 112.  
 Baldwin Six-coupled Switcher for the Youngstown Sheet and Tube Co., 113.  
 \*Baldwin Narrow Gauge Locomotive for the East Broad Top Railroad, 315.  
 \*French Locomotives, Switchers, 213.  
 \*Lima Pacific, 4-6-2 Type for the Central of Georgia, 378.  
 \*Porter Switchers at Home and Abroad, 100.

### Locomotive Running Repairs:

VIII. Fitting and Refitting a Throttle Valve, 163.  
 VI. Leaky Steam Pipes, 48.  
 V. Pounding, 12.  
 VII. Refitting Driving Boxes, 79.  
 \*Lathe, Davis Close Coupled, 276.  
 \*Lathe, New Design of Car Wheel, 397.  
 Leather Belts, To Soften, 10.  
 Lighterage in New York Harbor, 257.  
 Liners, Their Use and Abuse, 152.  
 Link Block, Position of, 86.  
 Locomotive Boiler Horse Power, 34.  
 Locomotive, Development of, 318.  
 Locomotive Efficient, Making the, 412.  
 Locomotive, Old Timer Down East, 298.  
 Locomotive Repairs, Saving Work on, 192.  
 Locomotive Running, Failures in, 9.  
 Locomotive, Time to Build a, 157.  
 Locomotives, Decapod Type for Russia, 256.  
 Locomotives, Equalization of Long, 221.  
 Locomotives, Horse Power of, 114.  
 Locomotives, Industrial, 115.  
 Locomotives, Inspecting Steam, 6.  
 Locomotives, Modernizing of, 222.  
 Locomotives, Speed and Power of, 18.  
 Locomotives, Tests of, 258, 294, 334, 342.  
 Lubricating Oils, Variety of, 97.  
 \*Lubricator, Sweeley Graphite, 60.

## M

Machine Design, Beauty in, 268.  
 Mahogany, 265.  
 Mason Engines on the Boston & Maine, 338.  
 Master Car Builders' Committees for 1917, 355.  
 Master Mechanics' Committees for 1917, 427.  
 Material, Worn Railroad, 376.  
 Materials, Specification and Tests of, 222.  
 \*Mechanical Drawing, Elements of, 50.  
 Mechanics, The Unexpected in, 319.  
 Metric System, The, 341.  
 Motion, Laws of, 98.  
 Motion, Perpetual, 127.  
 \*"Movies" on the Baltimore & Ohio, 139.  
 Mud Ring Leaking, 86.

## N

National Tube Company's Prizes, 6.  
 Natural Laws, Study of, 126.  
 \*New England, Engineering Triumphs in, 109.  
 Nickel Plating, 349.  
 \*North Shops, St. L. & S. F. Ry., Springfield, Mo., 41.  
 \*Nut Lock, Spring, 353.

## O

### Obituaries:

Baillie, Frank H., 31.  
 Booth, John Sinclair, 31.  
 Campbell, John D., 391.  
 Carney, Charles L., 175.  
 Cuntz, William C., 427.  
 Ely, Theodore N., 427.  
 Gayley, Oliver C., 67.  
 Hayes, William C., 31.  
 Hennessey, Thomas J., 31.  
 Hill, James J., 205.  
 Hill, John A., 67.  
 Lamonte, A. C., 67.  
 McKinney, Col. Robert C., 391.  
 Monkhouse, Harry, 427.  
 Saunders, Alexander, 103.  
 Sinclair, James, 31.  
 Vaughn, G. W., 103.  
 Voorhees, Theodore, 139.  
 Walsh, J. F., 205.  
 Wright, Amos W., 427.

Oil, Variation in Drops of, 14.  
 Oiler, Force Feed, 404.  
 Old Things Made New, 46.  
 \*Old Timer, An Irish, 117.  
 \*Old Timers, A Pair of British, 13.  
 \*Oroya Railroad, 145.  
 \*Oxy-Acetylene, Origin and Manufacture of, 253.  
 \*Oxy-Acetylene Welding and Cutting, 302.

## P

Paint, Removing from Iron, 163.  
 \*Painting, Development in Passenger Car, 166.  
 Passenger Cars, the Sanitation of, 239.  
 Passports, Antiquity of, 172.  
 Peat Powder on Swedish Locomotives, 142.

### Personals:

Adams, A. C., 138.  
 Adams, J. L., 242.  
 Alexander, J. R., 426.  
 Allen, Samuel G., 138.  
 Anthony, J. T., 320.  
 Attridge, O. H., 242.  
 Averill, E. A., 138.  
 Ayers, A. R., 391.  
 Baker, Edwin H., 139.  
 Baldwin, A. R., 320.  
 Baldwin, L. W., 30.  
 Barba, W. B., 426.  
 Barrett, C. D., 204.  
 Basford, George M., 139.  
 Beckner, C. N., 30.  
 Begien, R. N., 282.  
 Bell, W. J., 283.  
 Bennett, H. E., 174.  
 Benson, J. C., 391.  
 Bess, C. E., 426.  
 Bettenberg, N. C., 391.  
 Borell, Elmer A., 174.  
 Breckenridge, H. L., 242.  
 Brookhart, James W., 138.  
 Brown, A., 242.  
 Brown, A. B., 138.  
 Burkholder, C. J., 426.  
 Burgman, C. F., 66.  
 Butler, F. A., 426.  
 Burnet, R. W., 30.  
 Burns, C. R., 426.  
 Cathcart, H. N., 30.  
 Charles, M. G., 204.  
 Cleinor, H., 282.  
 Clements, B. A., 175.  
 Clements, M. F., 426.  
 Coburn, Ralph G., 138.  
 Coc, F. W., 138.  
 Coniff, P., 30.  
 Coniff, Philip C., 138.  
 Coon, J. W., 139.  
 Corbett, P., 30.  
 Crawford, G., 102.  
 Crammer, M. F., 242.  
 Cunningham, D., 320.  
 Cunningham, F. W., 102.  
 Cunningham, G. F., 282.  
 Curry, H. E., 426.  
 Cuyler, G. W., 320.  
 Dales, A. E., 320.  
 Daves, George W., 391.  
 Davis, B. H., 391.  
 Dean, Aaron, 282.  
 Denney, C. E., 426.  
 Dickson, John, 242.  
 Dice, Agnew T., 139.  
 Dillon, Sydney, 426.  
 Dow, T. W., 204.  
 Dowling, J. J., 426.  
 Drake, I. H., 354.  
 Drescher, P. L., 174.  
 Duff, Wm. A., 426.  
 Duffey, G. I., 66.  
 Duggan, George H., 139.  
 Dunkerley, W. L., 66.  
 Durham, George, 391.  
 Edison, B. B., 138.  
 Elmore, W. R., 391.  
 Embury, W. B., 138.  
 English, H. A., 30.  
 Ewing, Charles H., 138.  
 Farr, B. J., 391.  
 Finley, R. F., 242.  
 Finnegan, L., 30.  
 Fischer, J. C., 391.  
 Fitzmorris, James, 242.  
 Flannery, M. J., 391.  
 Flavin, J. T., 174.  
 Ford, A. B., 426.  
 Foster, Edwin G., 426.  
 Fox, M. I., 242.  
 Franey, M. D., 174.  
 Fryburg, F. W., 391.  
 Gaines, F. F., 66.  
 Galloway, A. K., 354.  
 Galloway, G. K., 174.  
 Gaston, J. H., 242.  
 Gemlo, William, 147.  
 Gray, C. B., 320.  
 Greenwood, H. E., 138.  
 Greenwood, W. E., 242.  
 Greer, Hugh E., 426.  
 Halliday, J. B., 66.  
 Hamilton, G. H., 242.  
 Hamilton, M. E., 30.  
 Hammack, Henry C., 204.  
 Hankins, Fred. W., 204.  
 Hanna, J. H., 66.  
 Harrill, R. F., 138.  
 Harris, E. J., 102.  
 Harris, L. J., 282.  
 Hartings, W. R., 282.  
 Harwood, G. A., 242.  
 Hedge, G. H., 30.  
 Hickson, C. W., 30.  
 Himmelright, R. J., 320.  
 Hines, I. D., 102.  
 Hodges, Geo., 174.  
 Hodgins, Geo. S., 340.



# INDEX FOR VOL. XXIX

- Hoffstot, H. P., 30.  
Hood, G. D., 320.  
Howley, Thomas E., 102.  
Humes, W. Sherman, 320.  
Houston, F. T., 242.  
Hussey, F. A., 426.  
Ingram, W. N., 354.  
Ivers, N. H., 320.  
Jackson, R. E., 355.  
Johnson, B. F., 138.  
Jordan, L. E., 174.  
Kinsell, W. J., 30.  
Karibo, M. J., 174.  
Keenan, E. C., 242.  
Keller, W. H., 282.  
Kelly, William, 391.  
Kendall, A. H., 391.  
Kennedy, J. V., 174.  
Kincaid, R. M., 30.  
Kinyon, A. G., 204.  
Kuchner, A. T., 174.  
Lamb, E. T., 66.  
Landreth, J. P., 426.  
Langton, G. H., 102.  
Lemmin, C. A., 426.  
Lewis, Thomas, 174.  
Lewis, Thomas, 242.  
Lounsbury, Chas., 291.  
Lowe, W. W., 138.  
MacDonald, A., 426.  
MacEnulty, J. F., 30.  
Malone, W. H., 354.  
Martin, A. W., 204.  
Mason, William W., 102.  
Maxfield, H. H., 204.  
May, E. H., 30.  
May, H. C., 66.  
McCallister, M. M., 283.  
McCarra, F., 138.  
McCarthy, F. W., 320.  
McCuen, R. F., 320.  
McDonald, R. J., 426.  
McKinney, C. R., 391.  
McMillan, E., 138.  
McNeill, J. J., 30.  
McQuilkin, W. R., 282.  
McRae, I. A., 102.  
Meeder, W. R., 283.  
Millice, R. N., 138.  
Morris, L. B., 175.  
Moshisky, P. C., 174.  
Moth, G., 66.  
Mullen, John F., 282.  
Murray, Samuel, 242.  
Norton, C. H., 354.  
Neal, W. M., 426.  
O'Neil, R. J., 320.  
Ostby, Oscar F., 282.  
Oviatt, H. C., 138.  
Parsons, Robert S., 355.  
Pearson, F. J., 138.  
Peers, M. A., 174.  
Pierce, F. L., 426.  
Pierce, H. E., 204.  
Potter, C. D., 204.  
Pyne, R. A., 355.  
Quigley, J. E., 354, 138.  
Rasnor, J. A., 354.  
Raycroft, T. J., 426.  
Reeder, N. S., 30.  
Regan, F. H., 391.  
Reid, H. G., 320.  
Rider, J. B., 30.  
Rogers, J. D., 426.  
Ronaldson, F., 30.  
Sawyer, E. T., 282.  
St. Clair, D. W., 242.  
Schule, Robert, 204.  
Searle, Jas. D., 66.  
Sexton, John R., 242.  
Sheffield, Edward, 30.  
Sinclair, D. W., 242.  
Slattery, J. T., 175.  
Smith, John L., 320.  
Smith, Oliver J., 391.  
Smith, M. R., 138.  
Staley, H. F., 66.  
Starkweather, F. F., 320.  
Stewart, R. L., 102.  
Stockbridge, W. A., 174.  
Stow, J. P., Jr., 138.  
Sumner, E., 282.  
Swift, A. O., 138.  
Taylor, G. W., 391.  
Tenney, J. W., 30.  
Thompson, W. O., 204.  
Trube, G. A., 320.  
Turk, James F., 139.  
Twist, G., 354.  
Wager, F. C., 242.  
Warford, N. L., 426.  
Warner, H. E., 138.  
Warthen, H. J., 138.  
Watters, R. J., 242.  
Webber, George, 204.  
West, A., 282.  
West, S., 138.  
Whitsel, N. B., 320.  
Williams, A. G., 242.  
Williams, R. J., 204.  
Williams, Thomas F., 102.  
Wilson, R. L., 102.  
Wintersteen, John, 66.  
Wood, F. O., 354.  
Wood, R. H., 426.  
Wood, W. H., 174.  
Woodard, W. E., 355.  
Worthmuller, L. S., 355.  
Woticky, C. B., 282.  
Pipe, Increasing Use of, 358.  
Pipe Manufacturing, 127.  
Piston Rods, Breakage of, 226.  
\*Piston Valves and Rings, Design of, 221.  
Poets, Inventors, 264.  
Pooling Engines, 305.  
\*Pop Valve for Locomotives, Improved, 277.
- Portraits:**  
Allen, Samuel G., 139.  
Averill, E. A., 139.  
Basford, George M., 139.  
Duggan, George H., 139.  
Carney, Charles J., 175.  
Clement, B. A., 175.  
Dow, T. W., 205.  
Gayley, Oliver C., 67.  
North, L. A., 332.  
Ostby, Oscar F., 218.  
Posthwaite, C. E., 31.  
Pratt, E. W., 220.  
Ramsey, Joseph, 283.  
Shaughnessy, Baron, 66.  
Slattery, J. T., 175.  
Turner, Walter V., 131.  
Underwood, Frederick D., 424.  
Walsh, John F., 205.  
Woodard, W. E., 355.  
Pound, A. Mysterious, 162.  
Powdered Fuel, Use of in Locomotives, 222.  
Production, Schemes for Increasing, 17.  
Progress and Principle, 122.  
Pulverizing Coal, Machines for, 393.  
Pumps, Massive Horizontal Pressure, 411.
- R**
- Rail Accidents, 292.  
\*Road Motor Car, "Thomas Transmission," 293.  
\*Rail System, Safety First Railroad, 118.  
Railroad, Erie, 67.  
Railroad Management in South Africa, 68.  
Railroad Notes, 33, 69, 105, 141, 177, 207, 243, 284, 321, 357, 392, 429.  
Railroad Operating, Development of, 53.  
Railroad Operating, First, 307.  
Railroad, Our Oldest, 4.  
Railroad Question, President Willard on the, 200.  
Railroads, Government Control of, 54.  
Railroads, What American Need, 64.  
Railroads, Government Ownership of, 64.  
Railroads, Pioneers of, 64.  
Railroads, Urges Help for, 91.  
Railroads, Valuation of, 67.  
Rails, Broken, 341.  
\*Railway Engineering in the Northwest, 1.  
Railway Machinery Parts, For Stronger, 98.  
Railway Medals, Award of, 63.  
Railway Men, Aristocratic, 269.  
Railway, Transandine, 101.  
Railways as Manufacturers, 304.  
Railways, Federal Valuation of, 157.  
Railways in Ireland, 5.  
Railways in the United States, Statistics of, 280.  
Rates Dispute, Curious, 161.  
Reading Youngster, The, 161.  
Red Cross Car on the Erie, 140.  
Resistance and Tonnage Rating, Train, 222.  
Resistance, Train, 270.  
\*Reversing Gear, Ragonnet, 379.  
Rocker, Offset, 86.  
Rules, Too Many, 99.
- S**
- \*Safety Appliances, 217.  
Safety Award, 111.  
\*Safety Film, New Railroad, 39.  
Safety First, 88.  
Safety First Exhibit, Washington, 67.  
Safety on the Pennsylvania, 292.  
\*Sander, A Self Cleaning, 281.  
Science and Engineering, 125.  
Science in Workshops, Deficiency of, 270.  
Semaphore for Railroad Crossings, 149.
- Shop Appliances and Practices:**  
\*Air Pump, Expander Plug for Stuffing Box, 403.  
\*Air Pump Lifter, 263.  
Arc Welder, 44.  
\*Attaching the Ends of Superheater Flues, 261.  
\*Body Bolt, Wrenches for Brake Valve, 371.  
\*Boring Bar for Cylinders and Valve Chambers, 149.  
\*Car Wheel Borer, 134.  
Case Hardening, 51.  
Castings, Stopping or Filling, 115.  
Copper Coating on Steel, To Put, 389.  
Corroding, Prevent Joints from, 366.  
\*Cutters for Facings Air Pump Valve Caps, 45.  
Drills, 51.  
\*Driving Spring Fuller, 264.  
Emery Wheels, Grinding on, 122.  
Hammers, Soft, 19.  
\*Hydraulic Press, 289.  
Iron Rust, To Remove, 133.  
Lathe Tools, Hardening, 393.  
\*Lubricator, Stud Repairing, 215.  
\*Milling Machines, Portable, 132.  
\*Pipe Vise, Pneumatic, 299.
- \*Press, Hydraulic and Drill Combined, 403.  
\*Rescuing Injector Rams, Device for, 372.  
\*Sand Trough, Adjustable, 9.  
\*Threading Machine, Improved Landis, 388.  
\*Three Way Cock for Air Presses, 338.  
\*Throttle Yoke, Jig for, 338.  
\*Top Heads for Air Pumps, Handle for Lifting, 371.  
\*Valve, Testing Device, 403.  
Valves and Packing Blowing, Tests for, 43.  
Welding Frames and Bolsters, 217.  
Shop Foreman, Selecting a, 270.  
Shop Men, A Plea for, 185.  
Shorter Hours, The Clamor for, 124.  
Signal System on the New York Central, 291.  
\*Signal, Three Position, 300.  
Signals, Deceptive Stationary, 208.  
\*Signals, Discretionary Obedience to, 352.  
Signals on the Pennsylvania, Change of, 292.  
\*Slack Adjuster, Automatic, 133.  
Sleeping Cars, Sixty-five Years Ago, 311  
Smoke Abatement in Chicago, 16.  
Smoke Washing, 224.  
\*Snow Plows, Rotary, 1.  
\*Snow Sheds, 2.  
Speed, Figuring Train, 187.  
Spikes, "Dog-Ear," 339.  
Southern Railway Extensions, 4.  
Springs, Helical, 266.  
Staybolts, Methods of Screwing in, 215.  
Steam Engine, Early Development of, 49.  
Steam Engine, Fault of the, 269.  
Steam Engine, Fireless, 140.  
Steam Engine, Mysteries About, 113.  
Steel, Hardening, 126, 330.  
Steel, High Speed Tool, 374.  
Steps, Dangerous Locomotive, 46.  
Stokers, Mechanical, 220.  
Stokers, Underfeed, 13.  
Stop Signal, Psychology of, the, 367, 376.  
\*Stop Signal, Bulla Automatic, 419.  
Strength and Stupidity Combined, 126.  
Subways, London, 110.  
Suits for Damages, Decisions in, 18.  
Superheated and Saturated Locomotives, 266.  
\*Superheater Appliances, Improvements in, 154.  
Superheater Locomotives, 221.  
Superheater Locomotives, High Water in, 89.  
Superheater Lubrication, Trouble in, 64.  
\*Superheater Performance on Locomotives, 330.  
\*Superheater, Robinson's, 38-240.  
Supply Manufacturers' Association, Meeting of, 218.  
Supplies, Purchasing Railway, 341.
- T**
- Tank Cars, 217.  
Telegram, The First, 430.  
Telegraph School, 153.  
\*Thermit Welding, Stability and Growth of, 181.  
Theory and Practice, 89.  
Thermostatic Control, 383.  
\*Threading Machine, The Landis, 47.  
Throttle Valve Trouble, A, 227.  
Tin Brought the Steam Engine, 307.  
Tires, Filling Flat Spots in, 78.  
Tool Steel Tips, Welding to Machine Shafts, 425.  
Tool Steels, Treatment of, 305.  
\*Track Scales, Testing Railway, 350.  
\*Train Brakes and Train Air Signals, 217.  
Train, The Safest Part of a, 270.  
Trains, Cost of Stopping, 227.  
Trains, Excessively Fast, 76.  
Traveling Engineers' Association, 284.  
\*Truck, "Fox," 238.  
Turn Table, Test on a, 299.  
\*Turner, Sketch of Walter Victor, 131  
Tyranny, Governmental, 228.
- V**
- \*Valve Gear, The Young Locomotive, 364.  
\*Valve Gears, Adjusting Walschaerts and Baker, 82.  
Valve Setting, 15, 377.  
Valves, Outside and Inside Admission, 86.  
\*Valves, Sizes of in Existing Locomotive, 312.  
\*Vanadium, Discovery and Qualities of, 27.  
Voltage in Railway Service, High, 161.
- W**
- Wages Question, The Railroad, 159.  
\*Walschaerts Valve Gear, Adjusting the, 8.  
Water Evaporated Per Pound of Coal, 14.  
Water Impurities, Trouble With, 61.  
Water, Methods of Treating, 241.  
Westinghouse Air Brake Co., Official Changes in, 423.  
\*Westinghouse, Memorial Tablet to George, 104  
\*Whistle, Mechanically Operated Shop, 116.  
Winter, Preparing for the, 369.  
Wood, Fireproofing, 65.  
Work, Discontent with Present, 228.  
Workmen, Ignorant, 32.  
Wrecking Train, Chancetaker Necessitates, 401.  
Workmen's Evening School of Long Ago, 314.
- Y**
- \*Yard Engine Adaptation to Service, 384.  
\*Young Locomotive Valve Gear, 364.



# Railway AND Locomotive Engineering

A Practical Journal of Motive Power, Rolling Stock and Appliances

Vol. XXIX.

114 Liberty Street, New York, January, 1916.

No. 1

## Railway Engineering in the Northwest—Rotary Snow Plows and Snow Sheds Ready for Winter

The indications that there is a likelihood of a severe winter brings into prominence the engineering necessities required to maintain open railroad tracks. Even in mild winters, short heavy snow storms not infrequently suspend railroad service for days. The situation has been met with admirable skill, and as a rule the ponderous snow plows make short work of the ordinary drift, so that by far the greater portion of the American railroads suffer

now so thoroughly estimated that surprises are rare. The varying conditions are all accounted for and nearly all provided for. Leaving the Pacific and following the line of the Fraser and Thompson rivers, the railroad passes through a comparatively low level. In this region a very heavy rainfall occurs, frequently over 100 inches per annum, with almost a total absence of snow. Then follows the Gold Range, the Selkirk Range, and the main

each other, and all subsidiaries of the same system, is because the Gold and Selkirk ranges are the first high mountains that encounter the moisture-saturated clouds that drift eastward from the Pacific Ocean, with the result that the clouds become largely condensed into rain in summer and snow in winter, and by the time that the air currents have reached the main ridge of the Rocky Mountains they have already been deprived of the

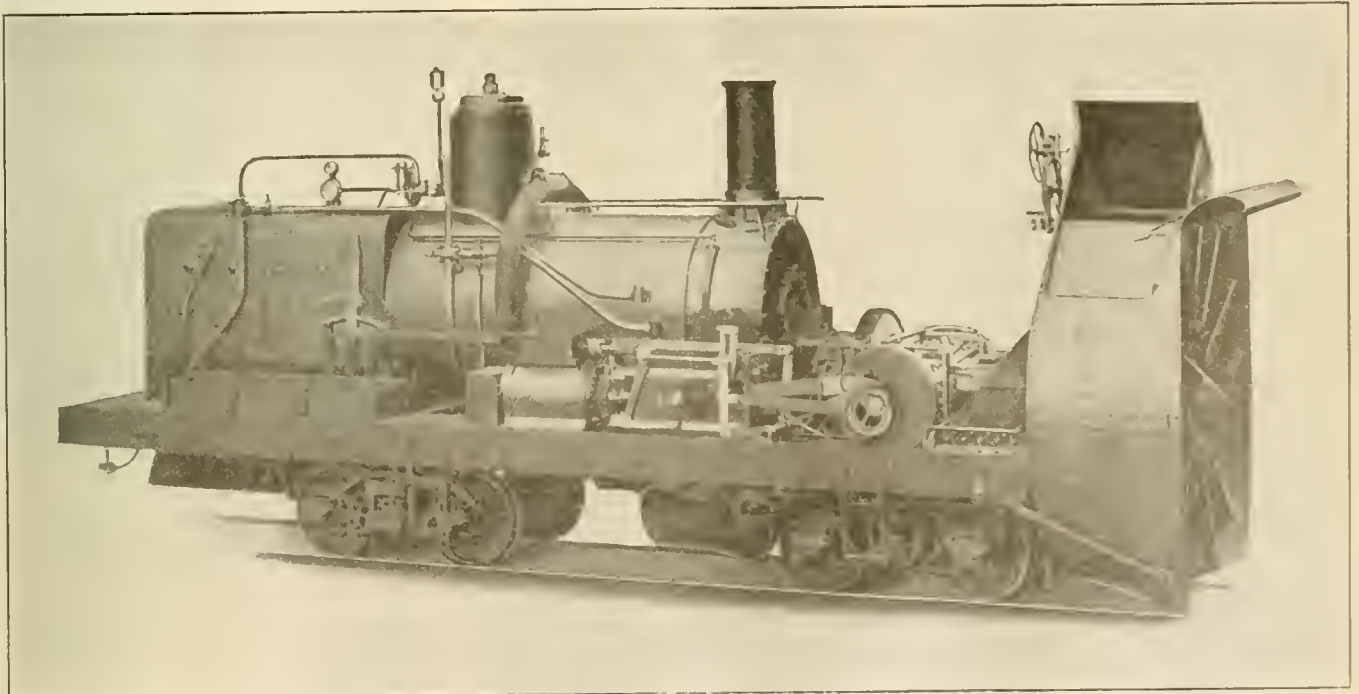

THE ROTARY SNOW PLOW WITHOUT HOUSING, SHOWING BOILER AND MACHINERY.  
American Locomotive Company, Builders.

comparatively little from the ravages of winter. In the Northwest, however, the situation is more serious. What is known as an open winter in the East is unknown there. Among the larger railroads the Canadian Pacific has, perhaps, had the hardest experience, and this is being avoided by the extensive system of tunnelling in the regions subject to the intermittent but inevitable snow slides. The climatic conditions along the road are

range of the Rocky Mountains. In these ranges the railway attains elevations respectively of 1,900, 4,300, and 5,300 feet. On the Gold Range the average snow fall is 25 feet; in the Selkirks, 35 feet, and in the Rockies from 14 to 15 feet. In the Selkirks it has been claimed that as much as 50 feet of snow has fallen in one season.

The variations of snow fall in these mountain ranges, comparatively near to

greater part of their moisture, and so the snow fall is much lighter, although the ridge is nearly 2,000 feet higher than the other adjacent ridges further west. The permanent way through the Selkirks being largely side-hill excavations; it will be readily understood that the grade runs at right angles to the paths of the inevitable snow slides, which in the early days choked up the railway with snow and debris.

The snow was not the only danger. The mountain sides are steep and are littered with loose masses of rock, and clothed here and there with heavy timber. As the snow moves in a mass downwards it gathers an immense accumulation of rock and timber which it hurls with a rapidly increasing and terrific force. Some idea of its velocity may be gathered from the fact that some of the largest snow slides have been timed on their descent, and after attaining full dimensions a distance of 2,500 feet has been made in thirty seconds. When it is considered that the density of the snow, by actual measurement exceeds 50 pounds for cubic foot, some measure of the amazing force of these snow slides may be roughly calculated.

The problem of saving a slender line of railroad from complete annihilation taxed the ingenuity of the best engineers, as no kind of structure could resist the impact of such forces as have been referred to. The early snow sheds were built of timber, but latterly ferro-concrete has been brought into service. The underlying idea of the various types of sheds has necessarily been to carry the descending mass harmlessly over and clear of the line. The contour of the ground is the main consideration in the formation of the shed. In the annexed diagram different types of sheds are illustrated, and these are capable of modification to an indefinite degree. The "A" or "K" type is perhaps the most familiar from pictorial representation. On the side of the mountain a rock crib is built, balks of timber dovetailed, bolted together, and fitted to the wall, being packed and loaded with massive pieces of rock, while the roof is finished off to the slope of the mountain so as to form a sharp continuation thereof. On the opposite side the uprights comprise huge posts spaced closely together, heavily braced and strutted, to secure strength for the roof. By giving the roof a sharp fall, the moving mass can be thrown clear of the structure on the lower side, to tumble into the valley below. In the "B" type the rock crib-work is placed on either side, forming virtually a wooden tunnel for the line. In "C," as the track runs through a shallow cutting it is necessary to build up the slope formation on the mountain side so as to lift the moving mass imperceptibly over the track. The "E" and "F" or "J" types are modifications of this design, and are generally introduced at such places where, owing to the configuration of the ground, the slide becomes somewhat spent before reaching the line. Type "D" is simpler, being adapted to those points where the line skirts a precipice, and where it is probable that the avalanche attains a high velocity, so that it clears the track quickly, instead of dropping directly on to it. Type "G" is useful where small pure snow movements are likely to be expe-

rienced, or where, owing to the open character of the location, the snow is likely to drift heavily. The "H," "I," and "L" types are more elaborate, and are modifications of one another. There is a double roof, with intervening rafts and bracing. These are used at points where the slides are apt to bring down masses of rock and timber. The final type "M" is a simple means of throwing the snow clear of the line. On the mountain side the heavy rock

In many instances water pipes are carried through the sheds, and hydrants and lines of hose are provided ready for instant use in case of fire. The sheds are patrolled day and night, so that an outbreak may be readily caught. Telephones are also in use. "Fire-breaks" occur at intervals in the sheds, so that in case of fire occurring only a limited portion of the shed can be destroyed. These "breaks" or open spaces are protected by "glance"

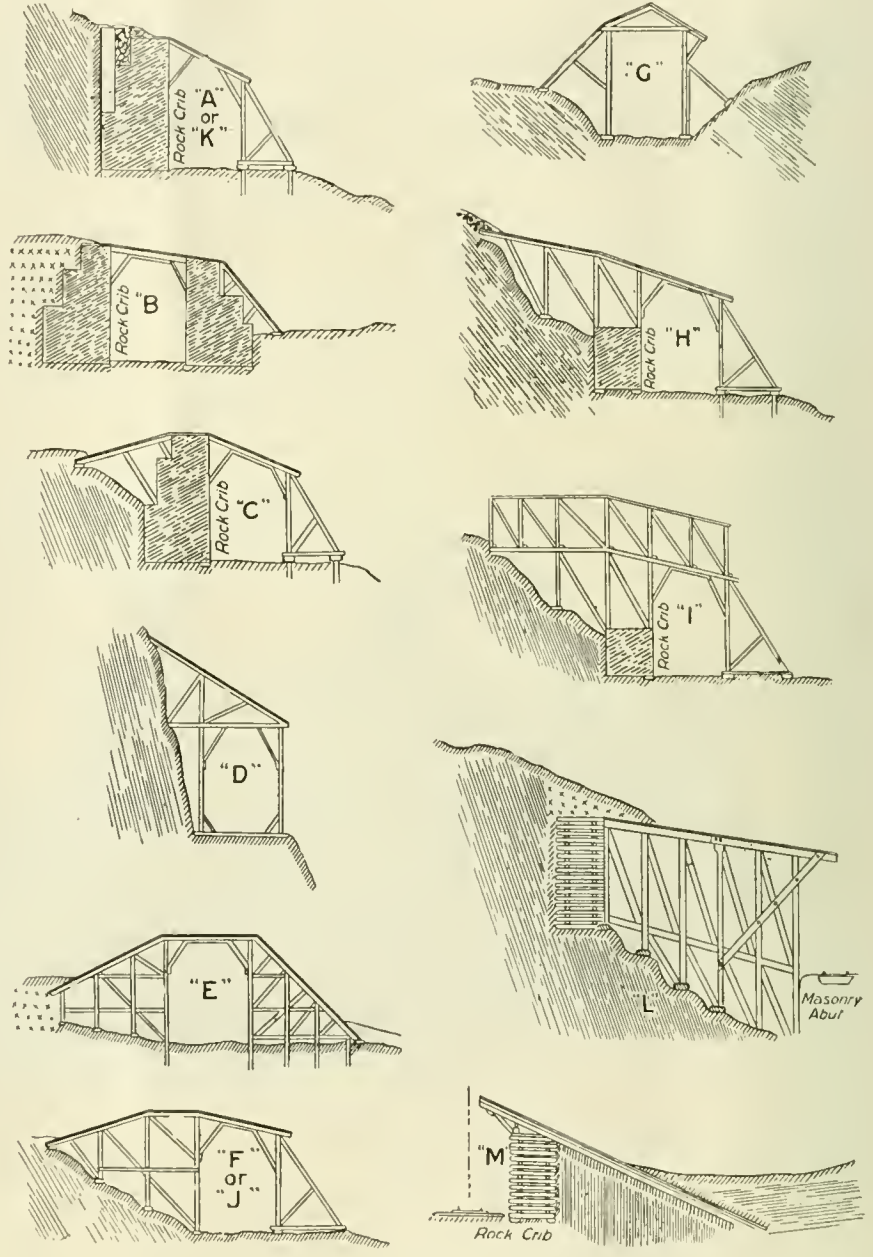

DIFFERENT TYPES OF SNOW-SHEDS.

crib is built up to support massive balks that are laid so as to point upward over the track. The lower ends of these timbers are buried, and the ground shaped to form a hollow. The descending snow rushes into the depression and up the inclined plane to fly into the air and to fall clear of the track, the clearance varying with the velocity of the avalanche.

cribs or split fences higher up on the mountain side, which serve to divide the avalanche, sending it flying over the adjacent sheds.

As we have stated, however, as the tunnelling proceeds the snow sheds are disappearing, and not only will the most serious of the avalanches be avoided, but the grades and curves are lessened, af-

fording a heavier haulage and less of risk.

Returning to the snow plow, it will be recalled that the wedge type plow of the last century was a mere attempt to clear a railroad by brute force, and the wedge-shaped plow, while it suited a light snow fall, had its limitations. With the advent of the Rotary snow fighting apparatus, an approach to regularity of service was immediately made. The appliance was first used on the Union Pacific in 1887, and promptly raised blockades that had tied up the road for weeks. Its introduction was rapid. Some remarkable exploits have been performed by the Rotary. In some Western storms that continued ten days it looked like a determined attempt of the elements to smother the machine, but it came out every time triumphant. When the construction of the Colorado Midland road across the Rocky Mountains in Colorado was first agitated, it was the general opinion that such a line could not be successfully operated for more

The engine consists of two horizontal cylinders with slide valves actuated by the Walschaerts valve gear. The boiler

should be thrown away from the road.

Various important improvements have been made on the Rotary. Among these



ROTARY SNOW PLOW CLEARING A SIDING.



INTERIOR OF SNOW SHED ON THE CANADIAN PACIFIC RAILWAY.

than four or five months in the year. Simultaneously with the beginning of the construction of the road came the Rotary and the road has never been closed for more than a few hours. Indeed the Western roads are as a rule kept clearer than some of the Eastern roads where there is less snow, and, of course, less efficient devices to meet an emergency. The representatives of foreign countries were not slow to see the merits of the Rotary, and its adoption in European railways was rapid and general.

It may be well to add, however, that the Rotary snow plow did not spring into perfection in a single day or year. In its present perfected form, as constructed by the American Locomotive Company, a reproduction of a photograph of which is shown in our frontispiece, it is the result of twenty years of practical experience combined with the best mechanical skill.

is of the locomotive type with Belpaire firebox, and has ample heating surface to give a good margin of steam capacity to meet all requirements. The wheel is driven by means of bevel gears on the main shaft and on the engine shafts.

The wheel is composed of ten hollow cone-shaped scoops. Each scoop is open its entire length on the front side through which the snow is taken in. Knives are hinged on each side of the opening, arranged so as to adjust themselves automatically into cutting position. The wheel is encased in a drum with a square front or hood. At the bottom the hood projects a few inches in advance of the cutting blades, while at the centre of the wheel, the knives are the first to encounter the snow. As a result, the whole front of the Rotary is a sharp, cutting edge. The shute in the top of the drum

is the design of the flanger and ice-cutters. Since the improvements in their construction it has been found impossible for the Rotary to be derailed by snow or ice. The ice-cutters and flangers are connected by iron rods to cranks on the balance shaft, and may be raised and lowered simultaneously by means of an air cylinder. The flanger points, which go below the rails, are bolted to the bottom of the wings so that, in case they strike an obstruction other than snow or ice, the bolts will be broken off and no other possible injury can be done to the flanger. Extra flanger points with bolts are carried in the tool box and in a few minutes the flanger may again be put in perfect working order. By these means the continued service of the Rotary is insured in spite of collisions with other substances embedded in the snow or ice.



ROTARY SNOW PLOW BUILT FOR THE DENVER, NORTHWESTERN & PACIFIC

is provided with an adjustable cover which can be turned to suit the direction in which it is desired that the snow

The Rotary is equipped with Westinghouse Air Brake, with 9 1-2 inch pump, and large reservoir capable of supplying

both air brake cylinder and flanger cylinder. The cab is partitioned off in front of the boiler, the front compartment being the pilot house, and the rear the engineer's cab. The machinery of the Rotary is underneath the floor of the pilot house and is covered with iron plates, thus securing the safety of those operating the machine. The American Locomotive Company publish a pamphlet of instructions in regard to the proper handling of the Rotary Snow Plow, and with these instructions in mind any locomotive engineer can readily handle the mechanism under any condition.

In conclusion it may be said that in general practice it is preferable that the Rotary should never be coupled to a train. With a train the inability to stop and start quickly enough may result in jamming the Rotary into a hardened hank and thereby fracture some part of the mechanism. It has also been found

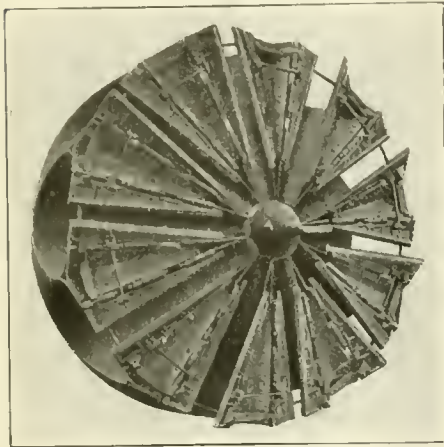

THE SCOOP WHEEL.

by experience that the best practice is to use one heavy locomotive to push the Rotary instead of two or three lighter engines. The impact of forces will then be found to be more readily controllable and the avoidance of sudden jerks avoided, as a slow beginning and a steadily increasing force is in the interest of Safety First rather than a sudden rush at a snow bank by the Rotary Snow Plow.

#### Southern Railway Extension.

Within the next few months the Alabama Great Southern Railroad will place in service its new double-track line between Chattanooga and Wauhatchie, and discontinue the use of the tracks of the Nashville, Chattanooga & St. Louis Railway between these points.

The new line which the A. G. S. will use has been under construction for several years past, and involves a large amount of heavy construction work, including a double-track tunnel through Lookout mountain 3,500 feet in length, steel bridges over Lookout creek and the N., C. & St. L. Railway, and concrete

bridges over numerous streets and highways.

In accordance with modern railroad construction, grade crossings, either of highways or of other railroads have been avoided, except three street crossings within the city limits of Chattanooga, where the separation of grades was impracticable.

The Southern Railway trains of the Memphis division will also use this route between Chattanooga and Wauhatchie, at which latter point connection for these trains will be made with the Nashville, Chattanooga & St. Louis Railway.

The opening of this new line, which it is expected will take place in the near future, will mark another advanced step in the operations of the Queen & Crescent route and the Southern Railway, and furnish another concrete example of the policy of these lines to install modern improvements, tending to better services rendered by these lines, even though large expenditures be involved.

#### Fifty Schoolboys Killed.

President Fairfax Harrison, of the Southern Railway Company, reports that during the fiscal year ending with last June, 147 trespassers were killed on the tracks of that road. He urges the development of a public sentiment that will put an end to the hazardous practice of trespassing. He has prepared a map showing the point at which each trespasser was killed and "it looks like a map of the monuments on the Chickamauga battlefield." . . . "Fully one-third of those killed were schoolboys, 'hopping' trains, and a large percentage were valuable wage-earners walking on the tracks to or from their work. Very few were 'tramps.'"

#### Missouri Grants Increase in Rates.

The railroads of Missouri have cause for congratulation. The State Public Service Commission granted them increases in both passenger and freight rates. The concession is not all the railroads asked, but it is worth while and shows that the commission aims to be consistent. The new rates have become effective after January 1. For years the railroads have been forced to haul passengers at two cents per mile. They requested an advance to three cents. The concession permits them to charge two and one-half cents per mile. The freight rate increase will aid the roads in regaining some of the losses they have sustained the past few years. Now if the railroads can secure like increases in all other states, both state and interstate rates, they will soon be able to make some of the much needed improvements and incidentally get out of the hands of the receivers.

#### Sleeping Car Cogitations.

Years ago when sleeping car travel was in its infancy, Bret Harte wrote: It was in a Pullman sleeping car on the Erie. After the first plunge into unconsciousness which the weary traveler takes on getting into his berth, I awakened to the dreadful revelation that I had been asleep only two hours. The greater part of the long winter night was before me to face with staring eyes.

With the recollections of last night's dinner weighing on me as heavily and as coldly as the blanket, I began wondering why over the whole extent of the continent there was no local dish; why the bill of fare at restaurants and hotels was invariably only a weak reflection of the metropolitan hostelrys; why the entrees were always the same, only more or less badly cooked; why the traveling American always was supposed to demand turkey and cold cranberry sauce; why the pretty waiter girl apparently shuffled your plates behind her back, and then dealt them over your shoulder in a semicircle, as if they were a hand at cards and not always a good one. Why having done this, she instantly retired to the nearest wall and gazed at you scornfully, as one who would say: "Fair sir, though lowly, I am proud; if thou dost imagine, that I would permit undue familiarity of speech beware." And then I begin to think of and dread the coming breakfast, to wonder why the ham was always cut half an inch thick and why the fried eggs always a glass eye that visibly winked at you with diabolical dyspeptic suggestions; to wonder if the buckwheat cakes would be brought in one minute before it was time to change cars.

#### Our Oldest Railroad.

The numeral adjective which begins the title, "Eighty-ninth annual report of the president and directors to the stockholders of the Baltimore & Ohio Railroad Co. for the year ended June 30, 1915," seems commonplace enough, but to the student of railroad history it is eloquent of the whole period of railroad activities in this country. For the first steps in the construction of the Baltimore & Ohio marked the real beginning of railway building in the United States. The company was chartered in 1827, in Maryland and Virginia, and actual construction was begun July 4, 1828—a significant date indeed, and particularly so in this case because it was Charles Carroll, last surviving signer of the Declaration of Independence, who laid the first rail. President Hadley of Yale aptly emphasized the romance of that scene when he wrote, in 1885: "One man's life formed the connecting link between the political revolution of the last century and the industrial revolution of the present."

## Hell Gate Bridge Nears Completion—Largest Arch Span in the World

Among the other great works completed, or nearly completed, at the end of the last year, is the arch span of the New York Connecting railroad bridge over the east channel of the East River in New York City, and is a part of the  $2\frac{1}{2}$  miles of bridge work which extends from 138th street to Lawrence street in Astoria, Long Island. The most notable feature in the arch span is its immense size. The length between the centers of skewbacks is 977 feet 6 inches. The distance between near sides of the tower piers at the coping is 1,015 feet. In the center of the arch the top chord on its upper edge clears the river at high tide 307 feet 6 inches, and on the lower side of the chord 265 feet. The construction of the arch was unique in engineering methods, a large triangular structure being designed on each side of the river

both halves simultaneously and the elevations although varying a few inches were speedily brought into place by the use of hydraulic jacks on the suspending structures, the variation arising from the fact that the Long Island counterweight had settled  $2\frac{1}{2}$  inches, while the Ward's Island side had settled only  $\frac{7}{8}$  inch. The junction of the arch was completed on October 4, and the roadway structure is now being rapidly proceeded with, and the work is in many respects recognized to be the boldest bridge erection scheme on record.

This Hell Gate bridge work has all been designed by Gustave Lindenthal, consulting engineer for the New York Connecting Railroad. The steel work was fabricated and is being erected by the American Bridge Company. The entire scheme of erection including the use of skew back



HOISTING A FLOOR BEAM ON THE HELL GATE BRIDGE.

which was held down by counterweights while each projecting half-span was in course of construction until the two halves could be connected in the center, when the whole span became self-supporting.

The accompanying illustration shows the arch completed and the roadway in progress of construction. The bottom of the floor or roadway system will clear the river at high tide 135 feet. The span is divided into 23 panels of 42 feet 6 inches each, the bottom chord sections weighing 180 tons and diminishing in proportion to 85 tons at the center. The arch span will have four railroad tracks between its trusses, and two highway tracks on brackets outside. The work on the extending span from the Long Island side was begun on January 22 of last year, and continued until seven panels stood out over the river. Work was then stopped on this half and the Ward's Island half of the arch was begun on May 28, and on August 30, six panels were completed, and operations were afterwards continued on

stays was developed by the Bridge Company under the direction of Mr. Emil Larsson, assistant chief engineer.

### Railways of Ireland.

The railways of Ireland traverse, principally the southern and eastern sections, over one-third—1,300 miles—of the total mileage of 3,403 lying within the consular district of Munster. The total passenger traffic is about 30,000,000 persons per annum, and of this Munster has only one-fourth. Of the freight traffic, Munster has probably one-half, owing to the movement of cattle, swine, and sheep. In 1911 the number of persons employed on Irish railways was 13,043.

The early part of the year 1914 was adverse to all transportation undertakings. The official statistics, which include the majority of the Irish railways, showed gross receipts from January to June, 1914, at \$10,393,380, a slight decrease from receipts for the same period in 1913. The

freight traffic for the year was decidedly better than the passenger traffic. The railways of Ireland were not taken over by the Government under the act of 1871, as were the English railways, and the employees were at times dissatisfied with the terms under which they labored.

### Engineering Fellowships.

It will be of interest to many of our younger readers to learn that there are now no less than fourteen Research Fellowships, for each of which there is an annual stipend of \$500, open to graduates of approved American and foreign universities and technical schools, in connection with one given by the Engineering Experiment Station of the University of Illinois. There will be five vacancies to be filled at the close of the current academic year. Research work may be undertaken in civil, electrical, mechanical and railway engineering and other branches, the complete details in regard to which may be had on application to Professor W. F. M. Goss, dean of the College of Engineering, Urbana, Illinois.

### Hornets in a Railway Car.

A short time ago a gentleman who had been rambling through some woods on the Missouri Pacific walked into a passenger with a hornets' nest stuck on the end of his cane. The cold weather had benumbed the insects, but under the warmth of the car they gradually displayed vitality, and before the would-be naturalist had presence of mind to throw the hive out of the window the hornets were buzzing all through the car and stinging the passengers. The presence of the conductor did not alarm the swarm for when he began to try and force them out he was attacked and severely stung. The train was stopped and doors and windows thrown open, but many of the passengers were stung before the hornets were forced out of the car.

### Oldest Locomotive Still Working.

One of George Stephenson's first engines is still in operation at Hetton Colliery in England, where it was first put into use and where it has been in constant service since 1822, the year in which it was built. Although the English government has offered to purchase it for preservation in one of the museums, the owners, say they will keep it.

When a fatal accident happens on a British railway its cause is thoroughly investigated by a Government inspector, who generally finds out the cause. While investigating lately the cause of an accident that happened on the London & Northwestern Railway, the statement was made that the passenger engine mileage for the last six years has been 36,000,000 per annum.

# New Additions to the Rules for Inspecting Steam Locomotives

Additions to the rules and instructions already in force in regard to the federal boiler inspection law have been approved by the Interstate Commerce Commission and the railroads, and take effect at the beginning of the present year. Among some of the additions are the following:

## RULES AND INSTRUCTIONS.

The railroad company will be held responsible for the general design, construction and maintenance of locomotives and tenders under its control.

The mechanical officer in charge, at each point where repairs are made, will be held responsible for the inspection and repair of all parts of locomotives and tenders under his jurisdiction. He must know that inspections are made as required, and that the defects are properly repaired before the locomotive is returned to service.

The term "inspector" as used in these rules and instructions means, unless otherwise specified, the railroad company's inspector.

Each locomotive tender shall be inspected after each trip, or day's work, and the defects found reported on an approved form to the proper representative of the company. This form shall show the name of the railroad, the initials and number of the locomotive, the place, date and time of the inspection, the defects found, and the signature of the employe making the inspection. The report shall be approved by the foreman with proper written explanation made thereon for defects reported which were not repaired before the locomotive is returned to service. The report shall then be filed in the office of the railroad company at the place where the inspection is made.

## ASH PANS.

Ash pans shall be securely supported and maintained in safe and suitable condition for service.

Locomotives built after January 1, 1916, shall have ash pans supported from mud rings or frames. Locomotives built prior to January 1, 1916, which do not have the ash pans supported from mud rings or frames shall be changed when the locomotive receives new firebox.

The operating mechanism of all ash pans shall be so arranged that it may be safely operated and maintained in safe and suitable condition for service.

No part of ash pan shall be less than 2½ inches above the rail.

## CABS, WARNING SIGNALS AND SANDERS.

All cabs shall be securely attached or braced and maintained in a safe and

suitable condition for service. Cab windows shall be so located and maintained that the enginemen may have a clear view of track and signals from their usual and proper positions in the cab.

Road locomotives used in regions where snowstorms are usually encountered shall be provided with what is known as a "clear-vision" window, which is a window hinged at the top and placed in the glass in each front cab door or window. These windows shall be not less than 5 inches high, located as nearly as possible in line of the enginemen's vision, and so constructed that they may be easily opened or closed.

Steam pipes shall not be fastened to the cab. On new construction or when renewals are made of iron or steel pipe subject to boiler pressure in cabs, it shall be what is commercially known as double strength pipe with extra heavy valves and fittings.

*Cab aprons.*—Cab aprons shall be of proper length and width to insure safety. Aprons must be securely hinged, maintained in a safe and suitable condition for service and roughened, or other provision made, to afford secure footing.

*Cylinder cocks.*—Necessary cylinder cocks, operated from cab of locomotive, shall be provided and maintained in a safe and suitable condition for service.

*Sanders.*—Locomotives shall be equipped with proper sanding apparatus, which shall be maintained in safe and suitable condition for service, and tested before each trip. Sand pipes must be securely fastened in line with the rails.

## THROTTLE AND REVERSING GEAR.

*Throttles.*—Throttles shall be maintained in safe and suitable condition for service, and efficient means provided to hold the throttle lever in any desired position.

*Reversing gear.*—Reversing gear, reverse levers, and quadrants shall be maintained in a safe and suitable condition for service. Reverse-lever latch shall be so arranged that it can be easily disengaged, and provided with a spring which will keep it firmly seated in quadrant. Proper counterbalance shall be provided for the valve gear.

Upon application to the chief inspector, modification of these rules, not inconsistent with their purpose, may be made for roads operating less than five locomotives, if an investigation shows that conditions warrant it.

## ACCIDENT REPORTS.

In the case of an accident resulting from failure, from any cause, of a loco-

motive or tender, or any appurtenances thereof, resulting in serious injury or death to one or more persons, the carrier owning or operating such locomotive shall immediately transmit by wire to the chief inspector, at his office in Washington, D. C., a report of such accident, stating the nature of the accident, the place at which it occurred, as well as where the locomotive may be inspected, which wire shall be immediately confirmed by mail, giving a full detailed report of such accident, stating, so far as may be known, the causes and giving a complete list of the killed or injured.

Note.—Locomotive boilers and their appurtenances will be inspected in accordance with the order of the Commission, dated June 2, 1911. Safety appliances on locomotives will be inspected in accordance with the order of the Commission dated March 13, 1911.

## National Tube Company's Prizes.

Among the finest exhibits displayed at the Panama-Pacific Exposition was that of the National Tube Company of Pittsburgh. This company was awarded a Grand Prize, which was the highest award conferred, but it seemed to us that each of the company's separate exhibits deserved a Grand Prize or at least a medal of honor.

The Grand Prize was given for the general excellence of the tubular products and fittings, the greatest merit being recognized in the following special products exhibited as representing the highest development of the art:

"National" oil well casing, tubing, drill pipe, drive pipe, rotary drill pipe and tubing with upset ends, line pipe, lead joint pipe, steel poles, standard pipe, black and galvanized, spellerized (4 inches and under) to minimize corrosion. Manufactured in 40 feet lengths when desired.

"National" Spellerized boiler tubes.

"National" protective coating.

"Kewanee" unions, valves and fittings.

"Shelby" seamless steel tubing—Special alloy tubing, boiler tubes, cylinders, flasks, steam pipe, drill pipe, mechanical tubing, trolley poles.

## The Cost of Repairs.

A superintendent of motive power was showing a Scotchman the wonderful improvements in the locomotives and explaining the merits of super heat. In opening the smoke box door to explain the apparatus, the Scotchman exclaimed: "Ha! ha! I see, I see, but mun it ma cost you something to keep the nick-nacks in repair."



# Installation Phase of Brake Operation

By WALTER V. TURNER, Assistant Manager, Westinghouse Air Brake Co.

In previous articles on the subject of braking ratio to be employed in the design of passenger car brakes, I have dealt chiefly with the definitions of expressions commonly used and have suggested certain requirements to be observed in connection with brake installation, but when considering in a general way the installation of a brake on a vehicle, it is necessary to employ a ratio of brake shoe pressure to empty weight of car which engineering practice and experience have determined as most desirable and this either for service or emergency operation, or both. When an installation is required wherein a certain rate of retardation in miles per hour per second is desired, or in which a certain stopping distance is specified, it is essential that all of the other factors be known or fixed upon, before the braking ratio is even considered.

There was some justification in the viewpoint that the brake manufacturers were concerned only with a recommendation as to what the braking ratio for a brake installation should be, until a few years ago, but since that time real engineering problems in brake design are presented by transportation companies. In some cases the question is, how much time can be saved on the schedule by an improved brake; in other cases the chief consideration is the distance in which a certain weight of train can be stopped on a level track from a 60 mile per hour speed; again, the most efficient brake all around for service and emergency operation may be desired and in one instance the actual rate of retardation in miles per hour, per second on the loaded weight of the car, both in service and emergency, and at different speeds is specified; therefore, wherever the question of brake performance is concerned, as in brake tests, safe and efficient service, the cylinder pressure from which the braking ratio is to be obtained, is the last thing to be considered and the customary statements, "90 on 60, etc.," have practically no application whatever to the matter in hand.

Under such circumstances, we are concerned with two separate and distinct phases of the braking problem, that is, the one where simply a question of brake installation is involved and the other where it becomes a much broader proposition of securing a specified or required retarding force, or more concretely, one phase as viewed by the car designer or car builder, the other by those concerned with efficient train braking.

From the foregoing it will become evident that we are concerned only with the ratio of the shoe pressure to the weight of the car until we actually reach the question of car design; therefore, because of hav-

ing the necessity for a base from which to work in cases where retardation requirements are not given, it is necessary to fix upon some arbitrary percentage, such as 60 per cent. for freight service and 90 per cent. for passenger service, or there would be no starting place for the design of a suitable brake apparatus, moreover without such a base the result would be a conglomeration of braking percentages; however, when retardation requirements are to be met, the braking ratio required must be left until other factors have been determined upon.

With this proposition, it will be clearly seen that no matter which phase we are considering, the question of cylinder pressure, ratio of leverage, etc., does not enter until we come to the actual lay out for a brake installation, and thus it is unnecessary and confusing to point out any of the other factors involved until such time as they arise from the nature of the case.

It will not be sufficient to dismiss the question of using braking ratio without mention of cylinder pressure initially by the statement that everyone knows when the term cylinder pressure coupled with "braking power" means anything and when it does not, for I take the stand that everyone does not know, and that those who do, often use it and confuse those who do not know, and further that the indiscriminate use of those two terms together is unscientific and exhibits a looseness of conception with consequent neglect of principles that has no place in engineering practice.

From these considerations, I would suggest that in the future recommendations should be for some arbitrary per cent. braking ratio for both service and emergency operations, without any reference whatever to the cylinder pressure from which it is to be realized—this question of cylinder pressure only to come into the statement when we can no longer proceed without it, which, obviously, is when some specific brake installation is being considered. The recommendation I would suggest to be 90 per cent. braking ratio for service and 150 per cent. for emergency.

In order that my position may be properly understood and the value of the suggestion appreciated, it is desirable to add the following, as it reduces the foregoing to a concrete engineering basis.

(1) That braking ratio per se has nothing whatever to do with cylinder pressure. This will be more clearly realized when it is considered that braking ratio is nothing but a ratio and that neither of the terms in the ratio is cylinder pressure—one of the terms being shoe pressure, the other the weight of the car.

(2) That neither braking ratio or cyl-

inder pressure bears any fixed relation to the retarding force developed.

(3) That to couple braking ratio and cylinder pressure together, unless actually laying out a brake installation, is confusing and misleading.

(4) That primarily when speaking of the force necessary to control a train, or what braking ratio it would be best to employ, the cylinder pressure is not a factor, but is merely one of the many details that come into the matter later. For instance, when kind of brake apparatus, existing practice, or car design, becomes the subject for consideration.

(5) That cylinder pressures for the service operations of the brake are now so numerous that if cylinder pressure is mentioned at all, all of them must be mentioned, or the particular equipment for which one is speaking must be specified and the discussion limited to this particular one.

(6) That if it is considered necessary to tack the brake cylinder pressure to braking ratio whenever this is mentioned, as is very generally done, no matter whether speaking of train control or brake installation, why not also mention the ratio of leverage to be employed, the ultimate pressure that will be obtained in emergency applications, since this is necessary before the lever designs can be made, the stresses permissible in levers and rods, the piston travel required to give proper shoe clearance, and any other details that are as essential to the brake question as is that of cylinder pressure.

All of these are essential factors at a certain stage of the consideration, but none of them need to be mentioned to assist in the discussion of what braking ratio should be employed and since not needed must necessarily make the discussion more complex and unintelligible. This may not appear so to the man long accustomed to using "90 per cent. braking power on 60 per cent. cylinder pressure" in the same sense as he would use a symbol, or who thinks of it as he would a single term, either of which make it mean something different to him from what it may seem to another, but the writer has found by tedious experience that if he can keep the two separated when discussing brake phenomena, such as wheel sliding, long and short stops, etc., that much more rapid headway can be made to a clearer and more intelligent comprehension that 90 per cent. braking ratio is 90 per cent. braking ratio, irrespective of the cylinder pressure, and is also able to dodge the most terrifying question he now is frequently called upon to answer, namely: "Why is it that 86 lbs. cylinder pressure will not slide more wheels than 60?"

# Simple Method of Adjusting the Walschaerts Valve Gear

By CLARENCE BODEMER, Master Mechanic, Louisville & Nashville Railroad, Decatur, Alabama

To set valves and make alterations on an engine equipped with Walschaerts valve gear, when the eccentric crank arm leads the pin in the forward motion.

Put reverse lever in extreme forward notch of quadrant, and place crank pin on

and the length B and F would remain the same as before.

If the marks on valve rod crosshead were as shown on Fig. 3.

The length F would be  $\frac{3}{8}$  in. longer than B, consequently, the lead in forward

back dead centers in forward and backward motions. After these marks have been obtained, the lines will show on valve rod crosshead similar to those in figure 2, but with a different amount between the front end and back end lines. The lead, however, in the forward and backward motion will be equal, and it will then only be necessary to lengthen the valve rod, the sum of the distance between the lines.

If the marks on valve rod crosshead were as shown on Fig. 4.

The length B would be  $\frac{1}{2}$  in. longer than F, consequently, the lead in the back motion would be one-half of  $\frac{1}{2}$  in. =  $\frac{1}{4}$  in. greater in the back motion than the forward motion. In this case pinch engine ahead with reverse lever in forward motion, and place crank pin on front dead center. Drive the eccentric arm directly toward the center of driving axle, until the 24 in. valve tram falls outside the back mark of the forward motion line  $\frac{1}{8}$  in. This will increase the lead in forward motion  $\frac{1}{8}$  in. and decrease the lead  $\frac{1}{8}$  in. in backward motion, thereby equalizing the lead in both motions.

When the distances F and B in any of the above figures are equal, it is never necessary to shift the eccentric crank arm, and the only change required is to lengthen or shorten the eccentric rod, so as to bring the forward motion marks in line

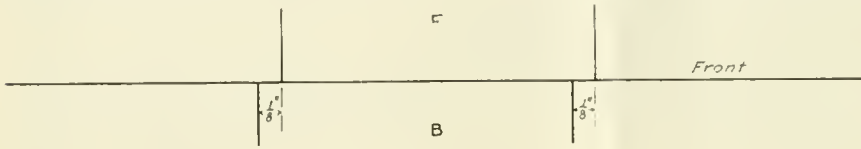

FIG. 1

forward dead center, then scribe a mark on valve rod crosshead with the standard 24 in. valve stem tram. With reverse lever in the same position, place crank pin on back dead center and scribe a mark

motion would be one-half of  $\frac{3}{8}$  in. =  $\frac{3}{16}$  in. greater in the forward motion than the backward motion, and in this case both the crank arm and the eccentric rod would have to be changed. First,

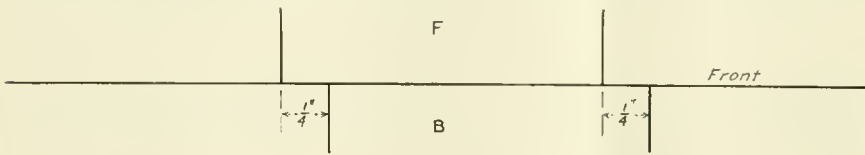

FIG. 2

on valve rod crosshead. These forward motion marks should be scribed on the valve rod crosshead, starting from a horizontal line and running above this line. Repeat this with reverse lever in backward motion until all four lines have been scribed on each valve rod crosshead, pinching wheels to take up lost motion in the ordinary manner.

The backward motion marks should be scribed starting from the same horizontal line, but running below this line. It is not necessary to pay attention to any port opening marks until the very last thing, after all changes have been made to eccentric arms, eccentric rod or both.

If the marks made on valve rod crosshead were as shown on Fig. 1.

The lead would be the same in both motions, consequently the eccentric crank arm would require no change of position. However, the eccentric rod would have to be shortened the sum of  $\frac{1}{8}$  in. +  $\frac{1}{8}$  in. =  $\frac{1}{4}$  in. This would make the forward motion lines drop in the backward motion lines and the valves would be square. This does not change the distance between the port lines designated by B and F, which are equal in this case.

If the marks on valve rod crosshead were as shown on Fig. 2.

The lead would be the same in both motions, consequently, the crank arm would require no change of position, but the eccentric rod would have to be lengthened the sum of  $\frac{1}{4}$  in. +  $\frac{1}{4}$  in. =  $\frac{1}{2}$  in.,

place the crank pin on front dead center pinching engine in forward motion, with reverse lever also in front notch, then knock the crank arm away from the center of the driving axle (to take up the lost motion in link gear), and then knock

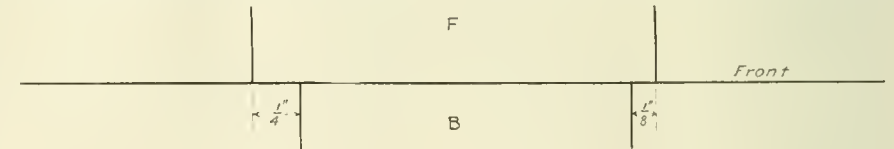

FIG. 3

it towards the center of the axle again until the valve tram falls  $\frac{3}{32}$  in. inside of back mark of forward motion tram mark  $\frac{3}{32}$  in., being half the amount that the forward lead exceeds the backward lead.

with the backward motion marks, and then the valves are set. The next thing to do is to mark the port openings on the valve stem with a short tram about 6 in. long, and then find the center between the port opening marks. Find the center of

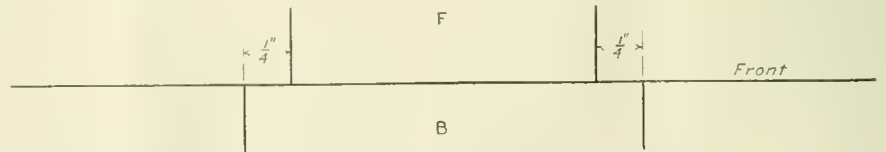

FIG. 4

Of course, the valve tram must be held at the valve rod crosshead, while the crank arm is being moved, so as to know when the crank arm has been shifted enough. Clamp the crank arm in this position and catch all four points over again by pinching wheels on front and

the marks on valve rod crosshead and set this crosshead so that this center mark drops in the 24 in. valve tram, then lengthen or shorten the valve stem until the center of the port openings marks on valve stem drops in the 6 in. valve tram, and the valves are complete.

**Progress in Flue Welding.**

BY JAMES MULCAHY, FOREMAN BLACKSMITH, CHESAPEAKE & OHIO SHOPS, COVINGTON, KY.

Twenty-five years ago flues were being welded in the open fire. The average output was 15 flues per hour. After a short time I constructed a coke furnace on which we averaged 25 flues per hour. Afterwards on a flue welder we raised the average to 35 flues per hour. At present, using our home-made flue hammers and an oil furnace, we can equal the output of any flue shop in the country. As an illustration a complete set of G Y flues are welded in 7 hours, or an average of 50 per hour.

Several years ago Mr. J. R. Gould, our superintendent of motive power, requested me to build a superheater flue machine. At that time we were removing the large flues from the Mikado engines and sending them to Huntington to have the safety ends welded, which caused considerable delay in addition to the expense of loading and unloading them. We built a machine adapted to welding the large flues at a cost of \$122.00. With this machine we can take a set of superheater flues and weld them in two hours, at a cost of about three cents a flue. They are welded and swedged at the same time. In the most of the flue shops the flue is welded and heated again to swedge it, causing delay and extra expense.

Flues should be scarfed, otherwise it will be found that in testing they will break off at the weld. Sometimes they will break off at the first blow of a hammer, whereas if the flues are scarfed they can be bent double without breaking. The doubling will take about eight blows with a sledge hammer, the safety ends can be scarfed at the same cost as if they were not scarfed, and if it should cost more it is cheaper in the end.

The Flue Rattler is also worthy of notice. In taking out a set of flues that have served their amount of mileage, put them in the rattler and more than likely pieces will break off from some of them. This will avoid the possibility of double welding. I may add that our flue welder is paid at the rate of 25 cents per hour, and his helper 22.40 cents per hour. Both earn their money.

**Handy Adjustable Sand Trough for Roundhouse.**

BY F. W. BENTLEY, JR., MISSOURI VALLEY, IOWA.

In cleaning out air sander trap pipes leading from the sand box, it is sometimes an aggravating proposition to keep the sand from falling down on other parts of the locomotive where it is prone to be the source of damage if enough of it falls in one place and it is not carefully cleaned away.

The sketch and photograph show an inexpensively constructed trough which can be used on almost any style of sander on which the trap is located below the runboard. The framework is of No. 8 copper wire over which the canvas sheet is stretched and hemmed over by means

will generally be found there when needed.

**Failures in Locomotive Running.**

BY M. H. GRAY, SAVANNAH, GA.

In the last few days in my territory, we have had a serious head-on collision. Several lives lost, considerable destruction of property. A man failure. The engineer forgetting an order. I have always thought that every man in the train crew, including the flagman, should have a copy of all orders. Someone may not fail, the flagman could have stopped the train, the baggage master could have stopped it. I say "man failure"—the memory failed, and this is the result. I have been in the business twenty-seven years and every time the engineer's mind failed, he carries everybody with him. The result—death with those that had their confidence in the man on the head end.

We have people born in all kinds of business with peculiarities, that will affect them, and get their minds all tangled up. I am going to mention a few. I saw an engineer one day going out on his run that had just received in his mail a pretty severe letter from a master mechanic about a delay. It had Bill pretty well worked up. His mind for that whole trip was tangled up with this letter.

A man told me once that just such a thing as this caused him to run by a board. I am not saying that this had anything to do with this case or any other. It takes a pretty good judge of human nature to tell what will worry a man. A good many times he has reported work on his engine. He comes down about two o'clock in the morning to go out; when he starts, he finds it hasn't been given attention. That is going to worry him. It takes a strict concentration of the mind all the time in this business. We have other people that had letters like Bill got, and any other thing, don't worry them. They go to sleep over it, and, as I say, give everybody a copy of the orders. The flagman could stop the train, with an emergency cord.

On one of these single track roads everybody is in a hurry. The engineer grabs his orders, puts them in his overalls pocket. He may tell the fireman if he is a white man. There are too much orders anyway. Too much for one man's mind to memorize. The engineer is overloaded already. When he gets in he has a long report to make out, on an engine, maybe it has been a rough rider, and he is practically all in, so it seems to me that giving the full crew all a copy, there may be a possibility of some one not failing at the proper time. It is an awful thing to think as an engineer that we have betrayed the trust that was in our care, and there is only one life here, and it can never be replaced; when the mind fails to act, or we have forgotten the orders.

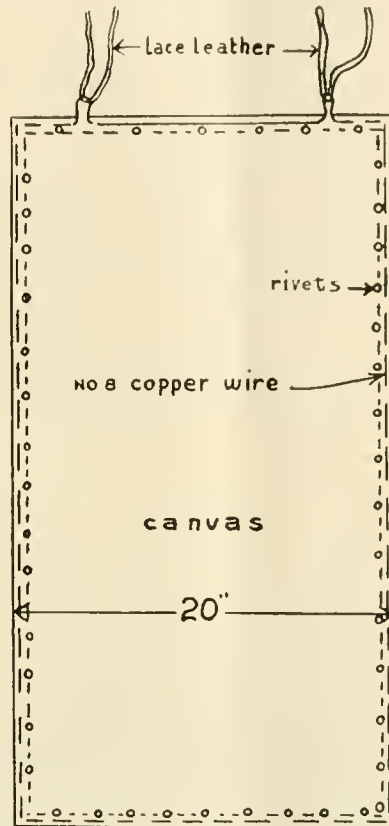

DETAILS OF SAND TRAP.

of either small rivets or glue. When in use the top of the device is held around the trap by means of two lace leather strips. This makes it possible to tie or fasten the bag up to almost anything which presents itself. The top piece being of copper wire makes it also possible to

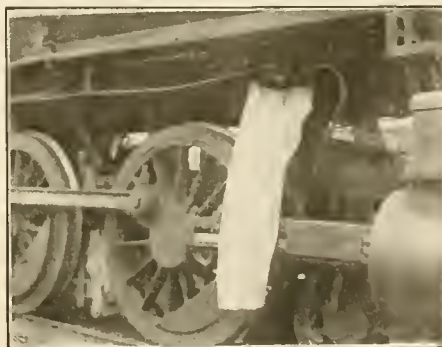

SAND TRAP ATTACHED TO LOCOMOTIVE.

bend the trough around any arrangement of piping leads that are set up.

Perhaps the strongest recommendation that the little device can present is that it is too small a piece of canvas to be used for numerous other purposes by roundhouse men, and as a result if kept in a certain place when not in use, it

## The Selection of Apprentices

By H. E. BLACKBURN, Instructor of Apprentices, Erie Railroad

The common saying that like father, like son, has been taken for the truth so long, that the little truth that it contains has been lost.

Any person would naturally think though that the son of a railroad engineer, who had reached the age of sixteen, would know why they placed a "pop" on the dome of a locomotive boiler, but strange to say this is the last person in the world to give you a good answer. As a rule all that they can see in a "pop" is a noise maker of the first variety, while the ever curious boy from the country will tell you it is there to keep her from "blowing up."

Of course we have to take into consideration that all boys are not born alike, in fact, some are born "short," and others "long." But mostly short when it comes to things mechanical, birth, surroundings, heredity and the lack of opportunities all have their effect upon the boy, and these things must be taken in consideration by the father before he holds the instructor responsible for his boy and his future.

As a rule the father comes home worn out after a hard day's work. And after supper he reads awhile, lies down to rest, or drifts out to places where he forgets his troubles. If he is one of the old school who stays in, he is generally too tired to instruct his boy in the trade he is following, or he is afraid the boy will ask him about something new that he is not up on, so as to give him an intelligent answer.

The result is that the boy drifts out on the street, and later on to the "movies," finally the father cannot keep the boy at home nights, and he drags him off to some shop to learn a trade, or rather to keep him off the street.

If the boy fails to pass the examination as laid down by the railroad company, the father becomes "sore" on the instructor, and begins to talk about his religion or nationality not being in harmony with the surroundings, while the real truth of the matter is the father never took enough interest in the boy, or even gave him a "look in" around a machine shop.

If you will look over some of the sheets turned in by mechanics' sons you will find the following:

Q.—Which are the main driving wheels on a locomotive?

A.—The wheels next to the steam main.

Q.—What is the lead on a valve?

A.—A heavy piece of lead to hold it down.

Q.—What is lap on a valve.

A.—Once around.

Q.—What is an oil plug used for?

A.—To keep the oil from running out.

Q.—Why is a sand box placed on the boiler?

A.—So that the conductor can stop the train on a wet day.

Q.—What are the injectors used for?

A.—So as to see how much water and steam there is on hand.

Q.—Why do they use two injectors?

A.—So if one blows up they can use the other.

Q.—What are the safety chains for?

A.—To keep the engineer in the cab, and to keep the fireman from losing his rake.

Q.—Why is lagging placed on a boiler.

A.—To keep the steam in the boiler.

Q.—How does the engineer open the cylinder cocks?

A.—He works his feet.

Q.—What two parts does the piston rod connect?

A.—The cylinders and the guides.

Q.—Which way will the engine go if given steam when the reverse lever is in the center of the quadrant?

A.—The wheels will slip and the engine will not move.

Q.—How many strokes will a piston rod make in one turn of the wheels?

A.—Eight.

Q.—What makes you think that you want a trade?

A.—The old man.

Q.—What trade do you wish to follow?

A.—Any old thing as long as it pays the most.

Q.—How far have you been in your studies?

A.—Five years.

Q.—Can you work fractions?

A.—Yes, a few.

Q.—Can you read a rule?

A.—Yes, some of it.

Q.—What is your nationality?

A.—Methodist, and I don't smoke cigarettes.

Q.—Have you any tools?

A.—Yes, a couple.

And so it goes on from day to day and the majority excuse themselves by saying that they are all out of "figgering practice."

The truth of the matter is that they have shunned the sound of the school bell, for that of running water or the "movie screen."

Perhaps if the father had interested the boy early in life in some mechanical toy things would have been different with the boy, for if he shows a liking for these he will unknowingly absorb the principles of mechanical or electrical engineering,

and while he may play at being a railroad manager, he may get the "bug" into his head that later may lead him to be the real thing.

Knowledge seems to be cherished by few, and neglected by many. No boy can be too well prepared for the trade that he takes a fancy too, and while many fathers secretly want their boys to become "chinists," they generally turn out to be "shinists" in some barber shop, just because the father failed to interest the boy, or the almighty dollar figured more than a good show at the trade.

It does not pay to run up against the prescribed examination, and then fall down. Examinations for those who are not prepared for them, will go on just as long as the parent is indifferent to the boy's future, and if the parent has a boy who can pass the examination, the apprentice school connected with a small shop is the correct place to learn the trade, for there (if the boy goes after it) he will get the hard knocks in working out problems in order to do jobs with few tools which are seldom twice alike. He will certainly have to think hard and use his ingenuity to the utmost, and this is what counts in the long run.

### Ill-Deserved Abuse of Locomotive Engineers.

By G. E. ROBINSON, ENGINEER.

Pick up any newspaper—morning, noon or night, and you will find a hair-raising account of some one killed or injured by some railroad train, and invariably the stereotyped words "run down by a train" appears in glaring capitals. This always seems to me like a travesty on justice. The train appears like a dog running down a rabbit, and the natural impression made upon a great many people is that the engineer does this maliciously, while the fact is that there is no class of men that will do more with the means at command to save human life, and it has occurred to me that if you would comment on this occasionally editorially, it might help to keep that misleading expression out of print. As you well know, there are many other expressions more suitable. For example the words, "He could not take care of himself," or, "He misjudged his distance," or, in the case of a survivor, "He will know better, next," might briefly convey the proper meaning.

### To Soften Leather Belts.

Mix 1 pint of boiled linseed oil, 2 ozs. of beeswax, 1 oz. of Burgundy pitch, 2 ozs. of turpentine, and melt them together over a slow fire. Rub the mixture into the leather on both sides thoroughly.

## Powerful Mikado Type of Locomotive for the Missouri, Oklahoma and Gulf Railway

The growing popularity of the Mikado type of locomotive is being acknowledged all over America. Its ready adaptability to every kind of service, especially for heavy and fast freight is undeniable, as well as mixed trains render it especially serviceable in the newer, and rapidly expanding railroad routes. The Baldwin Locomotive Works have recently completed four Mikado type locomotives for the Missouri, Oklahoma and Gulf Railroad. These locomotives exert a tractive force of 43,600 pounds, and represent practically the limit of capacity than can be secured in an engine of this type designed for operation on 70-pound rails. With high steaming capacity, and a ratio of adhesion of approximately four, the proportions of these locomotives are closely similar to those of the heaviest of their type.

arm of a bell-crank, to the other end of which the valve-stem is attached. The eccentric rod is suspended by a hanger, whose upper end is pinned to a block. This block slides in a link-shaped guide, which is secured, in a horizontal position, to a suitable support. The direction in which the locomotive will run, and the point of cut-off, depend upon the position of the block in the guide. In the present instance the gears are controlled by the Ragonet power mechanism, which relieves the engineman of considerable labor in handling the locomotive.

The main frames are  $4\frac{1}{2}$  in. wide, and the rear sections are separate pieces of slab form, arranged to accommodate the Hodges design of trailer truck. The equalization system is divided between the second and third pairs of driving-wheels. Back of the rear driving-wheels, the

sure, 180 lbs.; fuel, soft coal; staying, radial

Fire Box—Material, steel; length,  $114\frac{3}{16}$  in.; width,  $72\frac{1}{4}$  in.; depth (front),  $81\frac{1}{2}$  in.; depth (back),  $67\frac{1}{2}$  in.; thickness of sheets: sides,  $\frac{5}{16}$  in.; back,  $\frac{5}{16}$  in.; crown,  $\frac{3}{8}$  in.; tube,  $\frac{1}{2}$  in.

Water Space—Front, 5 in.; sides, 4 in.; back, 4 in.

Tubes—Material, steel; thickness, No. 9 W. G.—No. 12 W. G.; number, 38-265; diameter,  $5\frac{3}{8}$  in.—2 in.; length, 18 ft. 6 in.

Heating Surface—Fire box, 208 sq. ft.; tubes, 3,540 sq. ft.; firebrick tubes, 30 sq. ft.; total, 3,778 sq. ft.; grate area, 57.2 sq. ft.

Driving Wheels—Diameter (outside), 52 in.; diameter (center), 46 in.; journals (main), 10 in. x 12 in.; journals (others),  $9\frac{1}{2}$  in. x 12 in.



MIKADO, 2-8-2, TYPE OF LOCOMOTIVE FOR THE MISSOURI, OKLAHOMA AND GULF RAILWAY.

R. Q. Prendergast, Master Mechanic.

Baldwin Locomotive Works, Builders.

The boiler has a straight top and is built with longitudinal seams having a strength equal to 90 per cent. of the solid plate. The equipment includes a brick-arch and a Schmidt superheater with 38 elements. The fire-door is pneumatically operated, and there is a coal-pusher on the tender. The Master Mechanics' standard self-cleaning front end is applied. Two rows of Baldwin expansion stays support the front end of the crown, and 500 flexible stay-bolts are used in the breaking zone.

The steam distribution is controlled by piston valves 11 inches in diameter, which are driven by the Southern valve motion. This gear is similar to the Walschaerts, in that it uses a return crank and an eccentric rod. The forward end of this rod is connected, by a vertical rod, with one

locomotive is cross-equalized by two transverse beams, which are connected by a vertical link placed on the center line. This construction tends to prevent any transverse rocking action from being communicated from the driving-springs to the rear truck springs, or vice versa.

The tender frame is composed of 12-in. channels, and the tank is semi-cylindrical in shape. The weight of the tender, loaded with 8,000 gallons of water and 13 tons of coal, is 154,000 pounds. The trucks have cast-steel side frames and triple elliptic springs.

The leading dimensions of these locomotives are as follows:

Gauge, 4 ft.  $8\frac{1}{2}$  in.; cylinders, 23 in. x 28 in.; piston valves, 11 in. diameter.

Boiler—Type, straight; diameter, 82 in.; thickness of sheets,  $\frac{3}{4}$  in.; working pres-

Engine Truck Wheels—Diameter (front), 30 in.; journals, 5 in. x 10 in.; diameter (back), 36 in.; journals,  $7\frac{1}{2}$  in. x 10 in.

Wheel Base—Driving, 14 ft. 3 in.; rigid, 14 ft. 3 in.; total engine, 32 ft. 4 in.; total engine and tender, 65 ft.  $7\frac{1}{2}$  in.

Weight—On driving wheels, 176,600 lbs.; on truck (front), 20,200 lbs.; on truck (back), 34,100 lbs.; total engine, 230,900 lbs.; total engine and tender, 385,000 lbs.

Tender—Wheels: number, 8; diameter, 33 in.; journals,  $5\frac{1}{2}$  in. x 10 in.; tank capacity, 8,000 gals.; fuel capacity, 13 tons; service, freight.

Engine equipped with Schmidt superheater.

Superheating surface, 838 sq. ft.

# Locomotive Running Repairs

By JAMES KENNEDY

## V—Pounding

In all mechanism where the moving forces act reciprocally it is to be expected that a certain amount of wear will speedily manifest itself in what is known as pounding. With the increase in the size of the working parts of locomotives this chronic defect has perceptibly lessened. It still, however, remains what it has always been—one of the leading troubles in locomotive running and management. While it is, as we have said, to be expected, it should not, under any condition, remain unheeded. It should be taken as a note of warning, for neglect is almost always sure to lead to disaster. The location of the trouble is not always easy of discovery, and it should be looked for with carefulness.

A good method of locating a pound, after determining on which side of the engine the pounding occurs, is to move the engine until the main crank pin is on the top quarter on the side on which the pounding has been located, then block the driving wheels, and admit steam to the cylinder, and by reversing the lever so that the steam may act alternately on each side of the piston, the location of the pound will likely be detected. If there is no movement visible in the driving box or crosshead or main rod connection, it is safe to assume that the trouble is in the cylinder. The trained ear will readily detect the sharp, metallic sound of piston rings which is easily distinguishable from the duller sound of pounding on account of the wearing, or loosening of the wearing parts. A loose piston head may be said to have a sound peculiarly its own, partaking of both sounds previously referred to, and is usually much exaggerated in sound in proportion to the slight amount of lost motion that may have arisen from the loosening of the piston on the piston rod.

Some locomotives produce a pounding sound when running in full gear, and care should be taken not to experiment blindly with them. It may be taken that some of the intricate mechanism is not properly adjusted or balanced. It will be easily observed whether the pounding is of a constant or growing kind. If the sound is constant the trouble will likely be in the lack of compression as the piston approaches the end of the stroke. The sudden release of the steam at a high pressure in the cylinder rendering something of a shock. This is particularly noticeable when pulling a heavy load with a full stroke of the valves. It should be remembered that if the valves are properly proportioned and adjusted the compression which occurs as the piston approaches the end of the stroke should preclude any shock or apparent pounding, but the valve gearing seldom

retains its exact position for any considerable length of time.

Pounding may be caused by the loosening of the cylinders on the frames, and also by the piston striking the cylinder head. When the latter condition occurs the sound is of a loud and hard kind that is readily distinguishable. This condition should be guarded against by occasionally observing the striking points usually marked on the guides. There is always a tendency towards a lengthening or shortening of the main rod, according to the location of the main rod keys, which may culminate in a collision between the piston and cylinder head.

It is safe to assume, however, that in most cases of pounding the trouble may first be looked for in the driving boxes, and it is often found that the condition of the wedges in their relation to the driving boxes is the cause of the pounding frequently complained of in the locomotive. It would seem that no matter how carefully the wedge may have been fitted when the locomotive was constructed or repaired, the driving boxes will be found sooner or later to be loose in the wedges. The use of thin liners under the wedges and shoes in the process of exact adjustment during repairs, which is frequently unavoidable, leaves a condition that is slightly compressible, inducing lost motion, and in addition to this the heating of the boxes renders the loosening of the wedges sometimes an absolute necessity, but care should be taken to set the wedges up to their proper position again as soon as practicable. This precaution should be followed up continuously by the roundhouse men. Many frame fractures are due to the loosening of the wedges, thereby allowing the shock of the piston to strike with great force against the pedestal jaws. These shocks or blows are greatly increased when the wedges are loose in the boxes, and even if no fracture occurs to the frames the wear of wedges and boxes are very rapid when allowed to run loosely.

It has been noted that since the introduction of the Walschaerts and other outside valve gears, there is a tendency among some roundhouse men to evade the pit, with the result that the wedges are not receiving their proper attention. This should be guarded against.

It would hardly be possible to enumerate all the causes that lead to pounding. One of the common causes is in the fitting, or rather misfitting of the driving box brasses. When the brasses are bored out a little too large, they are easily passed as fitting, when in fact they are loose and invariably develop lost motion and con-

sequent pounding almost from the beginning of the service of the locomotive.

The brasses should be fitted carefully all around except a small portion at the two points or ends of the semicircle, where they may be slightly relieved. Nothing can ever remedy the defect of a loosely fitted bearing, except refitting.

The irregular distribution of steam, which may occur by reason of some slight distortion of the valve gearing, will also speedily create pounding on the side of the engine where the greater amount of steam is being used. An excessive amount of lead also has a tendency to beget pounding, as the shock of the admission of steam at the point of the center line of motion cannot have any other effect than that of a severe blow, and the multiplicity of such blows gradually finds a yielding point that soon gives vocal utterance to the weight of its overwork. This gives us another reason why the valve gearing should be constantly supervised, as errors of any kind in the valve gearing are among the certain causes of pounding in the working parts of the engine.

A dryness of any of the working parts of the engine will also, in addition to superinducing a heating of the parts, cause pounding or knocking. This is especially so in the case of the cylinders not being sufficiently lubricated. The same effect, in a lesser degree, will be noted if the rod brasses or any of the driving connections are allowed to approach a condition of dryness. A loose crank pin will also speedily develop into a knocking sound, as also will any fracture of the frames or deck casting or saddle or any of the heavier braces that may be attached to the frames. It may be said, however, in a general way, that the loosening of the wedges, either wilfully by careless changing of their position, or by reason of their wear, is the most common cause of pounding in all locomotives. The friction on the face of the wedges is very great, and the holding of movable wedges in position is a problem that has not yet been completely solved.

Wedges that are secured by a threaded bolt passing loosely through the binder and adjusted in position by well-fitting jam nuts securely tightened, are as reliable as any other method. Many clever devices have been tried and found wanting, and some still in embryo are full of promise. The complete solution of the problem of securing the proper position of the movable wedge would be an object of much importance in lessening the running repairs of a locomotive, and of more valuable service in transportation than the discovery of the River of Doubt or the North Pole.

## A Pair of British Old-Timers Engineering Curiosities of the Last Century

Writing about the last years of the broad gauge on the Great Western railway of England, Mr. E. L. Ahrens gives some interesting particulars in regard to a pair of old timers that were the last of their kind. Originally built at Bol-

ton until their abolition which occurred toward the close of the nineteenth century.

Of the speed records made by these locomotives, there is really no authentic account. That they ran at high speeds

that the boilers were too small, and the fire box space too limited to furnish a supply of steam to cylinders 18 inches by diameter by 24 inches in length.

Frequent derailments also led to change of diameter of bogie wheels and other idle experiments. Finally some mechanical genius suggested that flanges become part of the driving wheels and the mystery was solved. Looking back at these mechanical curiosities the most remarkable feature about their history is that they held their own so long in the face of improvements on other railroads. Possibly if the track had not been changed to the standard gauge these fossilized remains of a defunct period might have been consuming coal at the present day.

### Underfeed Stokers.

A locomotive engineer writing in the *Fireman's Magazine*, says: "The Pennsylvania Railroad has 375 locomotives equipped with the Crawford Underfeed stoker.

"When beginning the use of the stoker, a great deal of trouble was experienced with breakdowns and irregular distribution, but later on as the stoker developed, the weak points were discovered and remedied so as to overcome all trouble.

"Stokers are so arranged as to enable the plungers to distribute the coal evenly all over the firebox. It was thought at first that slack coal could not be used with the Underfeed type of stoker, but from experience we have had with run of mine lump and slack coal, the slack has proved successful. We have no engines assigned

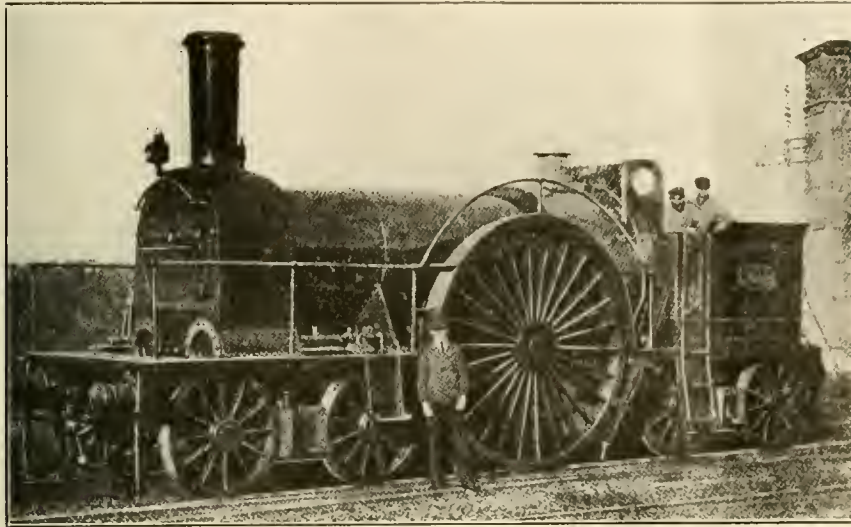

NINE-FOOT SINGLE 4-2-4 TANK ENGINE, BRISTOL AND EXETER RAILWAY, REBUILT 1873.

ton, by Messrs. Bothwell in 1853-4 to the designs of Mr. Pearson, of the Bristol and Exeter railway, they were 4-2-4 well tank engines with two bogies and 9-foot driving wheels. They were rebuilt in 1868-73 with driving wheels 8 feet 10 inches in diameter. A peculiarity in rebuilding was the reduction of the driving wheels at each succeeding reconstruction. This particular pair of locomotives held their own as far as speed was concerned for nearly 40 years. They remained at work until 1892, when the broad gauge was abolished.

Their numbers were 2001 and 2002, and a peculiar feature in their construction was the immense size of the driving axle-boxes in the inside frames. With a slight enlargement they would have made excellent triumphal arches, and as the weight of the driving boxes was naturally in proportion to their size their arrival in the repair shops was not heralded with any great amount of enthusiasm on the part of the gang allotted to repairing them.

At the end of their 40 years' service there was not much of the original engines left. The reconstruction engineers had not only changed the driving boxes, but the cylinders, and bogies and fire boxes, and while there was no evidence of any kind of improvement in all these changes, it seemed that the only lessons learned during these endless experiments were that they discovered what not to do next and went on from bad to worse

down hill there is no question. With a train of a hundred tons or little more they could move along slowly on a level track, but in attempting a grade they came to a standstill, and newer types of engines had to be hooked on and get

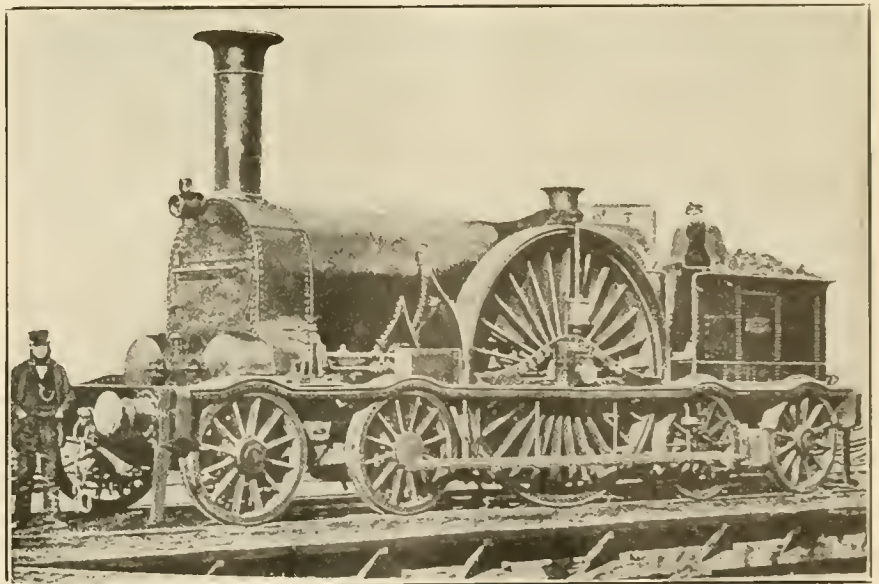

BRISTOL AND EXETER 4-2-4, 9-FOOT TANK ENGINE. BUILT BY BOTHWELL & CO., 1853-4.

them over the hill when their speed came back to them and they went on the home stretch on the down grade at record breaking speeds. It took the constructors nearly half a century to discover

to regular crews. All of our engines are run in pools. Each fireman on our division gets a stoker equipped engine an average of twenty days a month, and they never fail.

## Department of Questions and Answers

### Pounds of Water Evaporated Per Pound of Coal.

C. B., Bucyrus, Ohio, asks: How many pounds of water should be evaporated per pound of coal in a locomotive? A. The number of pounds of water that may be evaporated per pound of coal in a locomotive boiler depends entirely upon the quality of the coal used. With a fair quality of bituminous coal an evaporation of 7 to 8 pounds of water per pound of coal is considered good locomotive performance. With anthracite or hard coal the evaporation is even lower than the above, and would be placed between 6 1-2 and 7 pounds.

### Factor of Adhesion and Total Area of Flues.

C. M. W., Ottawa, Canada, writes:—Will you kindly give me a short formula for working out the factor of adhesion on a locomotive with 142,000 pounds on driving wheels, and a rated tractive effort of 33,000 pounds, and how the factor is arrived at? (2) Also explain the difference between the cross sectional area of the tubes on a locomotive and the area of the tube opening or the total opening through the tubes. A.—Divide the weight on the driving wheels by the tractive effort, thus:  $142,000 \div 33,000 = 4.3 =$  factor of adhesion. (2) The area of a flue two inches in diameter amounts to 3.142 in., which is found by multiplying the square of the diameter of the flue by .7854, thus:  $2 \times 2 \times .7854 = 3.142$  nearly. Then multiply this sum by the number of flues. This will be the sectional area of the flues as far as the opening of the flues is concerned.

### Variation in Drops of Oil.

H. K., Corning, N. Y., writes: Please explain why some drops of oil are larger than others when fed through a lubricator. With some kinds of oil the drops are small, while with other kinds fed through the same lubricator the drops are at least twice as large. Is it the weight of the oil that controls the size of the drops, or is it the thinness? I suppose it is in the weight of the oil. A. The supposition that the variation in size of oil drops is due to the properties of the different oils is correct. Other things being equal, the greater the specific gravity or weight of an oil, the thicker it will be. The variation in size is influenced then by both weight and thickness, heavy, thick oils producing large drops and light, thin oils small drops. The reason for this is not difficult of explanation. Heavy, thick oils have a greater viscosity than do thin oils; that is, they are more sticky; the particles

of which they are composed have a greater tendency to adhere to surrounding surfaces, and to cohere to each other, than do the particles of thin oils; while on the other hand, drops formed from thin oils have a greater tendency to rise through the column of water in the lubricator glass than do the drops from thick oils. From this it follows that the particles of heavy oils being more adhesive to surrounding bodies and more cohesive to each other, and having a less tendency to rise in water, due to their weight, they naturally grow quite large before there is sufficient force developed to detach them from the lubricator feed plug, while, as stated before, drops formed from thin oils have a greater tendency to rise and are less adhesive, consequently they are detached and rise while yet small.

### Burst Flue.

S. Y., Aramato, New Zealand, writes: A tube burst in an engine and the driver applied the brake and got out of the cab as the escaping steam was scalding him. The flue, 11 feet in length, was partly decayed, and the hole in the flue was about  $\frac{3}{8}$  inch in diameter. Ashes were found in the cylinders, and the right hand cylinder was cracked. The engine driver was fined one pound for reversing the engine. Would the ashes be drawn into the cylinders by reversing, and would the steam and water go down into the cylinders carrying ashes there? A.—Assuming that the engineer closed the throttle and applied the brakes the reversing of the engine was not necessary, but in any event the ashes would rush into the exhaust cavity and reach the cylinders. That the engineer did the best he could is very evident, and he should have been commended for his high courage and prompt action instead of being fined, but the ways of some officials are past finding out.

### Broken Air Pipe.

G. H. P., Willow Glen, N. Y., writes:—On an engine with two  $9\frac{1}{2}$  in. air pumps, the discharge pipe of the No. 2 air pump was broken along the road, and this pipe was plugged, and after that the No. 1 pump would pump but 40 lbs. air pressure. Can you tell me the cause of this? A.—You have failed to state whether the governor stopped the pump at this time or whether the other pump was in such an inefficient condition as to be unable to raise the pressure to a higher figure.

Assuming that it was stopped at 40 lbs air pressure by the governor, it would indicate that a bad leak was started in the excess pressure governor pipe at the same time the accident occurred to the pump

discharge pipe, or that a brake pipe leak had developed in the meantime which in volume exceeded the capacity of the feed valve.

It is also possible for the brake pipe feed valve to stick shut and produce this condition, but in any event you should have inquired from the shop repairman concerning the defect he found to exist when the engine was brought to the shop.

### Defective E. T. Brake.

G. H. P., Willow Glen, N. Y., writes:—I make a brake application and move the brake valve to release position and the driver brake releases, and when the brake valve handle is brought back to running or holding position, the driver brake re-applies, can you tell me what causes this? A.—You evidently have a leak in the distributing valve release pipe, probably between the brake valves, and are holding the brake valve in release position long enough to overcharge the pressure chamber of the distributing valve which causes the re-application as the valve handle is returned to running position. With a long train, this re-application is a usual result, as the pressure in the head end of the train is higher than at the rear end during the release and at this time the head auxiliary reservoirs tend to charge to a higher pressure than the rear ones, and when the brake valve is returned to running position, the feed valve adjustment may be at a lower figure than the auxiliary reservoir pressure on the head cars and a re-application of brakes is the result. This also affects the distributing valve in the same manner, although it may be augmented by an enlarged feed groove in the equalizing piston bushing.

### Variations in Brake Application.

H. A. B., Harrisburg, Pa., writes: What is wrong with the No. 6 E. T. equipment when the brake remains applied with a blow from the exhaust port of the automatic brake valve after a light application of either the independent or automatic brake valve, but after a heavy application with either brake valve the brake releases properly? A.—It is due to a leaky application piston packing ring in the distributing valve accompanied with a certain amount of frictional resistance to movement of the application piston, thus after a very light application, the application piston graduating spring is unable to return the application piston to lap position and a flow of air from the main reservoir into the brake cylinder continues and the brake cylinder pressure instead of returning the application piston to release position, leaks by the packing ring into the application cylinder and causes the



blow at the emergency exhaust port of the brake valve.

This defect becomes noticeable with the beginning of cold weather as the lubricant becomes stiff and the leather less pliable and the ring leakage may have no particularly noticeable effect in warm weather if the valve is well lubricated, but as weather conditions change, the badly worn ring or worn piston bushing or the ring being stuck in the piston groove, produces the effect you mention.

#### Defect of the Distributing Valve.

W. L. B., Harrisburg, Pa., writes.—How is the signal pipe of a locomotive overcharged when the reducing valve operates correctly until after the independent brake is applied, then the pressure in the signal pipe goes up to 65 or 70 pounds? A.—You should first note whether this occurs with the independent brake valve in application or on lap position. With the handle in lap position it would indicate that the reducing valve was at fault, but if it occurs with the valve handle in application position it may be from several different sources. A test should be made for a leak into the application chamber of the distributing valve in the usual way. This leak may be from either of the brake valves or from the equalizing slide valve or graduating valve of the distributing valve. If no leakage can be found and the brake application continues to overcharge the signal pipe when the independent valve is in application position it is reasonable to assume that the application piston packing ring of the distributing valve is at fault. Under such circumstances a leak past this ring will permit air pressure to flow from the brake cylinders into the application cylinder and cause the increase of pressure in the signal pipes as a back flow into the signal pipe can take place through the independent valve when it is in application position. This is usually accompanied by an unusual amount of friction in the application portion of the distributing valve.

#### Brakes Freezing Up.

W. M. B., Buffalo, N. Y., writes: Why is it that on some engines freezing up of the air brake system takes place in the distributing valve sometimes in the hose couplings between the engine and tender, and sometimes in the pipe around the main reservoir? A.—It is due principally to the different methods of piping and the main reservoir and air pump capacity employed. The condition of the air pump is also a factor, but as a general proposition the smaller the main reservoirs and the shorter the air pump discharge and circulating pipes, the further the point of freezing will be away from the main reservoir.

With an overheated air pump or an incorrect piping arrangement, or insufficient length of piping, the freezing may take place in the brake pipe under the tender or in the hose couplings between the engine and tender, while with correct installation or liberal lengths of air pump discharge pipes, the freezing usually takes place about the main reservoirs, which is technically the correct place, as the freezing and cut off of air supply is then detected by a lowering of the pressure in the brake system before the pressure is depleted to a danger point, where, if the freezing occurs in the brake pipe, it may not be discovered until such a time as a brake application may become necessary, which might result in an accident. This matter of freezing up of the brake system is one of the very strongest arguments in favor of ample air pump and main reservoir capacity and standard piping arrangements.

#### Defective Reducing Valve.

W. L. B., Harrisburg, Pa., writes.—How is it that a reducing valve that is repaired and tested on a shop rack can be made to overcharge the signal line after it is applied to a locomotive. I have seen this done with several quick movements of the independent brake valve after 45 pounds pressure is in the application cylinder of the distributing valve? A.—It is generally due to too neat a fit of the supply valve piston of the reducing valve, but in any event the reducing valve is not in a condition that will permit it to accurately control a small as well as a large volume of compressed air, thus a quick movement of the independent brake valve opens the reducing valve and it cannot shut off rapidly enough to prevent an overcharge of the reducing valve pipe from where it flows into the signal pipes.

#### Universal Valve Operation.

L. M., Philadelphia, Pa., writes.—If the quick service feature of late types of triple valves is essential to brake operation on long trains in both freight and passenger service under modern conditions, why is it that there is no quick service feature in the universal valve of the U. C. equipment? A.—This valve was designed as the pneumatic portion for electric brake operation or for the electro-pneumatic brake, and when the magnet portion is added and the universal valve is operated with electric current, it embodies the most perfect quick service feature yet devised.

#### Grinding and Polishing Knives.

Use a wheel covered with leather, and the face dressed with a cake made of the finest washed flour emery and beeswax.

#### Annealing Small Castings.

Bury the castings in lime or chalk place in an iron box and heat up to red. Then let them cool gradually, and they will be as soft as can be made. Copper may be further softened by heating and quenching in water.

#### Iron in Lead.

Iron railings embedded in lead lack the element of durability. Apart from the softness of the lead which readily yields to pressure, at the point of junction of the iron with the lead, corrosion, when moisture is present, is in constant process, and in the course of time iron bars over one inch in thickness will be reduced to a mere thread. This is the result of galvanic action.

#### Corrosion of Iron and Steel.

A question we frequently see discussed is, which metal is more subject to corrosion, iron or steel? The Iron and Steel Institute of Great Britain has been wrestling with the question mentioned, and they have concluded that it is impossible to tell unless full details are given concerning the nature of the corroding media. In ordinary air gray cast iron is more resistant to corrosion than steel, but when both are submerged in water there is little to choose between the metals.

#### Valve Setting.

Disregarding the position of the engine entirely, set the eccentric carefully on one of its dead centers. Then adjust the length of the eccentric rod, or valve stem, so that the valve will show one port wide open. If, on turning the eccentric to the other dead center, the valve shows the other port just wide open, then the length of the rod is correct. If, however, the valve moves past the wide open port, measure the distance from the end of the valve to the edge of the port, and mark half-way. Then adjust the length of the rod so as to bring the valve to this mark, which will give the proper length. When the valve rod length is found, set the engine on the dead center and advance the eccentric ahead of the crank until the valve shows the required lead—usually about 1-100th of the diameter of the cylinder. Then fasten the eccentric and the job is done. Ten minutes should suffice for the whole job, where the engine is of the ordinary slide-valve type. The same methods hold good for any valve motion of the slide type, whether rocking, piston, or single valve automatic.

This method has not only the quality of correctness, but it avoids the prolonged labor of turning the engine, which in the case of a heavy flywheel is no trifling matter, especially if a belt is attached.

# Railway & Locomotive Engineering

A Practical Journal of Motive Power, Rolling Stock and Appliances.

Published Monthly by

## ANGUS SINCLAIR CO.

114 Liberty St., New York.

Telephone, 746 Rector.

Cable Address, "Locong," N. Y.  
Glasgow, "Locoauto."

### Business Department:

ANGUS SINCLAIR, D. E., Prest. and Treas.  
JAMES KENNEDY, Vice-Prest.  
HARRY A. KENNEY, Secy. and Gen. Mgr.

### Editorial Department:

ANGUS SINCLAIR, D. E., Editor.  
JAMES KENNEDY, Managing Editor.  
GEO. W. KIEHM, Associate Editor.

### London Representative:

THE LOCOMOTIVE PUBLISHING CO., Ltd.,  
3 Amen Corner, Paternoster Row, London, E. C.

### Glasgow Representative:

A. F. SINCLAIR, 15 Manor Road, Bellahouston,  
Glasgow.

### SUBSCRIPTION PRICE

\$2.00 per year, \$1.00 for six months, postage paid in the United States, Canada and Mexico. For other parts of the world, \$2.50, or ten shillings. Single copies, 20 cents. Remit by Express Money Order, Draft, Post Office Order or Registered Letter.

Mailing address can be changed as often as necessary—always give old and new address, and if you subscribe in a club, state the name of the agent.

Please give prompt notice when your paper fails to reach you regularly.

Entered at the Post Office, New York, as Second-class Mail Matter.

## Smoke Abatement and Electrification of Railway Terminals in Chicago.

Twenty-four committeemen, and seventeen of an expert staff, with numerous assistants have worked for four years in pillars of cloud by day and pillars of fire by night in the city of Chicago, and the result of their labors are before us in the shape of a massive printed report of nearly 1,200 pages. Nothing shorter than the report itself could be anything like a complete account of the means and methods used in the great work they have accomplished. Like other civic, state and federal reports we doubt if anybody will ever read all of it, but its conclusions are of much value. The committee can rest on their laurels. William F. M. Goss, Dean of the College of Engineering, University of Illinois, chief engineer of the expert staff, has thrown into the work of the experts under his supervision a

degree of thoroughness that is amazing. We can now tell within an infinitesimal decimal fraction where all the smoke comes from. Two things are distinctly proven. First, that the smoke from locomotives entering the city of Chicago and remaining there and returning from thence on their destined journeys is neither here nor there. If it was entirely eliminated the air would be no clearer, or at least the difference would not be visible to the naked eye. Nobody need remain any longer in the dark about that. Then in the second place the idea of electrifying the railways terminals in Chicago is little short of an absurdity. The cost would mean complete financial ruin to nearly all of the roads. Many of them are near enough to ruin as it is. The smoke nuisance would, as we have stated, still remain in scarcely perceptible diminution, while the burden of debt would be insupportable. These two conclusions may be said, therefore, to dispose of any change in the complexion of the railroads, and if the people of Chicago are determined to abolish smoke they must look elsewhere for the remedy.

As a matter of fact they will not have far to look. The report states where the sources may be found. High pressure steam and stationary plants furnish nearly one-half of it, or to be exact 48.53 per cent. Low pressure steam and other heating plants 19.2 per cent. Furnaces for metallurgical manufacturing and other processes 18.83 per cent. This leaves a little over 13 per cent. to be divided between steam locomotives and steam vessels. Of course the amount of smoke attributed to locomotives is, in a city like Chicago, much greater than that produced by steam vessels, the latter being almost a negligible quantity.

In view of these facts and figures it is surprising how much complaint has been made in regard to the smoke of locomotives in the windy city. That the part contributed by the locomotives to the smoke nuisance has always been grossly exaggerated was well known among scientific men generally, and railroad men particularly. But the clamor for abatement against the locomotive went on, and the call for complete electrification became a common cry, which, in view of the undisputable facts presented will surely now be hushed. The railroads have trouble enough with fool legislators and cross-grained commissioners without adding to the burden of misrepresentation and hysterical abuse.

Indeed it is not too much to claim that strangers visiting Chicago are more likely to form a more nearly just estimate as to the causes of the dark cloud that envelops the city than the dwellers within its gates, because the stranger is not burdened with tradition or warped by prejudice. If he comes in a dry season when the unimproved streets are like the

beds of (dried up) rivers—deep in powdered dust and ashes mixed with gray sand, not to speak of the perpetual excavations that are continually going on in the streets that have already been paved, but are not allowed to remain fit for traffic, and if he adds to this the shining sands of the lake shore lifted by the winds that have gathered much momentum over the flat lands of Kansas and Iowa, in addition to the thousands of tall chimneys belching forth their sombre clouds of smoke inseparable from the use of bituminous coal, often the foulest and cheapest kind, one does not require to be a learned professor or an analytical chemist to discern the causes and sources of this segregation of maddened molecules that constituted the sirocco that beclouds the darkened city in an atmosphere murky as the third circle of Dante's Inferno.

In this war of the elements, however, it appears that when the average Chicagoan sees a locomotive, as through a glass darkly, coming thundering along in a pall of smoke, this must be the cause of the pestilential pollution, and he vents his spleen upon the railroads, and hastening to some sheltered shade he coughs up a few bilious observations, and launches them into the lurid pages of some daily newspaper.

Then there is a saving grace that the bewildered citizen never thinks of. It is this: Coal smoke has a certain purifying effect on a filth laden atmosphere. Prof. Goss and his phalanx of experts proves conclusively that certain poisonous gases take wing and fly away when the carbonic particles of which the smoke is composed cleave their way through the lighter gases. Other matter also when impregnated with the vapor evolved from the passionate exhaust of an overworked steam engine crowd together, like cattle in a storm, and forming into minute solid particles drop to the earth, not that the streets of Chicago require foreign matter dropped upon them, but the action of the law of gravitation acting upon the solidified or incrustated atoms they cannot remain in the intangible air like winged spirits, but sink into the earth, like the blood of a Plantagenet.

Of course, the report, luminous with intelligence, does not recommend the smoke emanating from soft coal as a means of atmospheric purification. The report simply sets forth that the smoke has its bright as well as its dark side, and the former should not be overlooked or misrepresented, or underestimated. Neither should the committee be considered as looking upon coal smoke as a blessing in disguise. It should not be permitted to exist any longer than is possible, but in the mad rush for high steam pressures scientific skill has not fully discovered the means of catching every particle of carbon that joins in the whirlwind rush through the flues before they have had

time to burst into flame. Improvements in this direction are being constantly made, and nowhere more persistently or more successfully than in the steam locomotive, but the ideal end eludes and probably ever will elude the seeker after perfection.

In conclusion it might be well to quote the exact words of some of the conclusions to be drawn with reference to the extent to which smoke discharges from steam locomotives pollute the atmosphere of Chicago. This study of the results of the committee's numerous tests and analyses, made in connection with the investigation of smoke discharges, justifies the following conclusions with reference to the extent to which the smoke discharges from steam locomotives constitute a source of atmospheric pollution.

Steam locomotives consume 11.94 per cent. of the total fuel consumed within the city limits of Chicago, and they rank fourth as a fuel consuming service.

Steam locomotives are responsible\* for 22.06 per cent. of the total visible smoke discharged within the city limits of Chicago, and they rank third among all services on the basis of total quantity of visible smoke produced.

Steam locomotives are responsible for 7.47 per cent. of the total solid constituents discharged into the atmosphere in the smoke of all services within the city limits of Chicago, and they rank fourth among all services on the basis of the total amount of solid materials discharged into the atmosphere in smoke.

Steam locomotives are responsible for 10.31 per cent. of the total gases of combustion discharged into the atmosphere in the smoke of all services within the city limits of Chicago, and they rank fourth as a service producing polluting gases discharged into the atmosphere in smoke.

The contribution made by the different classes of steam locomotives to the pollution of the atmosphere of Chicago are as follows:

Locomotives engaged in suburban passenger service contribute 1.54 per cent. of the total visible smoke, 1.97 per cent. of the total dust and cinders of smoke and 0.74 per cent. of the total polluting gases of smoke discharged annually into the atmosphere of Chicago.

Locomotives engaged in through passenger service contribute 2.07 per cent. of the total visible smoke, 1.80 per cent. of the total dust and cinders of smoke and 0.89 per cent. of the total polluting gases of smoke discharged annually into the atmosphere of Chicago.

Locomotives engaged in all passenger services combined, including suburban passenger, through passenger and passenger transfer, contribute 3.80 per cent. of the total visible smoke, 3.81 per cent. of the total dust and cinders of smoke and 1.73 per cent. of the total polluting

gases of smoke discharged annually into the atmosphere of Chicago.

Locomotives engaged in road freight service contribute 2.01 per cent. of the total visible smoke, 1.18 per cent. of the total dust and cinders of smoke and 0.66 per cent. of the total polluting gases of smoke discharged annually into the atmosphere of Chicago.

Locomotives engaged in yard freight service contribute 10.25 per cent. of the total visible smoke, 1.73 per cent. of the total dust and cinders of smoke and 5.17 per cent. of the total polluting gases of smoke discharged annually into the atmosphere of Chicago.

Locomotives engaged in all freight services, including road freight, yard freight and freight transfer services, contribute 16.85 per cent. of the total visible smoke, 3.34 per cent. of the total dust and cinders of smoke and 7.57 per cent. of the total polluting gases of smoke discharged annually into the atmosphere of Chicago.

#### Schemes for Increasing Production.

We have recently received several circulars from concerns that allege they are making specialties of schemes for increasing the productive capacity of workmen, ideas for getting more and better work from mechanics; and a mass of literature aimed at increasing the production of every laboring force. Although we are employers of labor, and expect to receive a fair return for the wages paid weekly, we do not sympathize at all with the various schemes designed to increase the output of our employees. The writer worked at the bench of machine shops in various parts of Great Britain and Canada before settling in America, and has to confess that when he went to work in a contract shop in the United States he was shocked with the hard labor the mechanics habitually performed.

In Europe there is an underlying sentiment among workmen that they must work steadily and refrain from loitering over any operation in hand; but there was no rushing and there ought to be no such methods of working. In the United States it is habitual for foremen to domineer over workmen and find fault with the slow progress they are making. One of the first jobs the writer was employed in an American shop was fitting a set of locomotive guides. He had done such work before and proceeded in a workmanship manner, neither hurrying nor loitering. He was dreadfully shocked when about half done with the job, to have the foreman come and ask if that work was going to last all the week. The foreman, who was a Welshman, added, "Remember you are not working in England now." This was soon very apparent and the reflection came that should any employer of skilled mechanical labor in Europe attempt to bully their men into

working harder than the shop traditions called for, he would soon have a strike upon his hands.

#### The Mechanic's Debt to Chemistry.

The technical education being conferred on mechanics and workmen generally by night schools and other mediums of information is causing a demand for technical reading away beyond anything ever thought of a few years ago. This is particularly the case with subjects that involve a knowledge of chemistry. Mr. Arthur D. Little, chemical engineer of Boston, in a recent address said: Chemistry enters so intensely, even though unobtrusively, into every phase of modern life and thought that it is impossible to present in any adequate degree the real dependence of the commonwealth upon the work of chemists past and present.

"Industrial revolutions are seldom chronicled and more rarely celebrated, though their influence upon the welfare of mankind may be as profound as that of other revolutions, the records of which are traced in blood. It can no longer be said, as it was said of the father of chemistry, who was one of the martyrs of the great French revolution, 'The republic has no need of chemists.'

"If we were to take away what chemists have contributed, the whole structure of modern society would break down at once. Every commercial transaction in the civilized world is based upon the chemist's certificate as to fineness of the gold which forms our ultimate measure of values. Faith may remove mountains, but modern society relies on dynamite. Without explosives our great engineering works would cease. Without it there could be no Panama Canal or hydraulic tunnels, no methods of modern warfare.

"Prices rise and fall with the variations in the gold supply as the barometer responds to the changing pressure of the atmosphere, so that to the cyanide and chlorination processes, which have so greatly increased the world's supply of gold, must be ascribed a potent influence on market prices everywhere.

"With the development of the steel industry have come great fortunes and greater corporations, bringing with them social benefits and social problems hitherto unknown. This industry rests pre-eminently upon the work of the chemist, as its greatest master has been quick to testify, and is today at every point under the strictest chemical control.

"The Bessemer process alone was estimated by Abraham S. Hewitt to add, directly and indirectly, \$2,000,000,000 yearly to the world's wealth. Of this vast sum, Bessemer himself retained in all about ten million dollars, or one-half of one per cent. of his contribution to the community in a single year.

"And this is characteristic generally of the rewards which come to chemists. They are not taken from the common fund; no man is poorer for them; their recipient has made others richer in those rare cases in which he has become rich himself."

#### Curious Decisions in Suits for Damages.

What we consider to be an extraordinary decision was made in a suit in Glasgow, Scotland, brought by John Duffy, a trackman, for compensation owing to damages incurred while boarding a moving train. The workman was on his way to work and got on the side platform or running board, as we would call it, of a moving train from which he fell and sustained injuries for which he claimed compensation. While on the running board he attempted to open a compartment door, but his shovel, which he was carrying, got entangled with his feet and he fell, sustaining serious and permanent disablement.

The sheriff, who is the judge of such cases in Scotland, decided that the man had been injured in the course of his employment and awarded him compensation at the rate of eleven shillings and three pence a week till further orders of the court. The decision arrived at by that sheriff was to follow a precedent established by the Court of Sessions, which had awarded damages to a porter who was injured while trying to board a moving train, an act strictly forbidden by the company's rules.

These decisions make us believe that the Scottish law courts are much more inclined to favor the workmen than are the United States courts. We believe that in both the cases mentioned an American judge would have held that they were cases of contributory negligence, that the men were injured through their own carelessness and that they were not entitled to damages.

#### Power of Industry.

We have recently seen recommendations given to young men concerning the best way to achieve success in life. The writer has watched the careers of many men and has concluded that the secret of the most successful ones is that they worked harder than those who fell behind.

It is the honest, "plodding" workman who rises to an elevated position in the world. Work is, as a rule, at the foundation of all true success. Brilliant ability, fine thorough education, powerful friends, are not to be despised, but they cannot supply the place of personal toil and patient, painstaking industry. The lives of all great men who have risen from ob-

curity to eminence teaches the world the lesson that success is founded upon hard work. President Lincoln literally worked his way up from a common laborer to the highest position in the United States. Nearly all our successful railroad managers have worked their way from the bottom through persistent hard work, President Underwood of the Erie being a shining example. Among other railroad dignitaries who have risen by the same force are Daniel Willard, Howard Elliott, William R. Scott, A. J. Earling, George W. Stevens, Samuel Rea, C. H. Markham and many others.

#### Speed and Power of Locomotives.

"A Constant Reader" of RAILWAY ENGINEERING has conceived the idea that it would improve the working of the locomotive to equip the engine with speed regulating or controlling appliances, such as are used on stationary engines. Speed regulating appliances would certainly be out of place on a locomotive, which unlike more steam engines, varies in speed and power all the time it is working. The man holding the throttle lever of a locomotive performs the functions for which automatic cut-off valves and other regulating devices are applied to other forms of engines. On European railways the throttle valve of a locomotive is called "the regulator," and that is the function that it performs.

In place of the constant speed and steady load of the stationary engine, the conditions under which a locomotive works are such that it must be able to run at any intermediate speed between starting and the attainment of full velocity, and at the same time develop all the degrees of tractive effort within its capacity. At slow speed the maximum pull must be exerted in order to start the trains easily, and for this reason live steam is admitted to the cylinders during 80 to 87 per cent. of the stroke. As the speed increases it is necessary to reduce the admission period, thereby increasing the expansion of the steam; therefore, for any speed there is some point of the valve to cut off the live steam at which the engine will develop its maximum power. There is also some minimum velocity at which the full horse power of the locomotive is obtained, and after this velocity has been reached the horse power remains constant or slowly decreases. This critical point may be taken at 700 to 1,000 feet per minute piston speed. It has been, and still is in some cases, customary to use certain ratios based on cylinder volume for locomotive proportions. These ratios lead to individual preference in such matters as rate of combustion per square foot of grate, length of tubes, the evaporative value of firebox heating surface, or value of tube heating surface in relation to the length, making it desirable to proportion boilers

upon more uniform methods in which these variable factors are given due consideration. Some time ago a report was drawn up with the object of reducing this matter to a more uniform basis, substituting for the ratios hitherto employed cylinder horse power requirements. This method has given favorable results where employed.

#### Job or Position?

Our work is whatever we choose to make it; either "just a job" or a position, a daily grind with only the pay envelope as the goal, or a stepping stone toward our ultimate success. The man who does all his work with his hands and body will never have anything but a job. We can so dignify our labor that the most menial task will become a position. Even the man digging ditches can mix brains with his work and when he does, he is no longer a ditch digger. He is a constructor of sewers. Some day, too, he'll be "The Boss."

It may seem to us that we are paid too little for our services. If we feel that way we need only remember that this is a free country and that our employer can't compel us to work for him. Then we ask ourselves how much more our services would be worth some place else. We may think the boss fixes our wages. He doesn't. We do that ourselves. If we feel that we are doing more than we are paid for, we probably are being paid for more than we do.

The work we are doing now may not be the kind we would most prefer to do, but as long as we are at it, give it the best that's in us. As early in life as possible we should get into the kind of work we want to follow, but until we find it don't neglect the work at hand.

While we are working forget about the pay envelope, put our best ideas and efforts into whatever we are doing and don't be content until we feel that we have done our level best. And then try to do a little better next time. When we work in that spirit it will not be long until the result will show in the pay roll. But that will be the least satisfying part of our compensation.

#### Female Help Discredited.

The fate of war has led to the employment of women as clerks and in other lines of industry in Great Britain, and we understand that the women are proving themselves as satisfactory as male employes. A change in public sentiment must have taken place from what it was twenty years ago, when an attempt was made to introduce female clerks on the London & Northwestern Railway. A prominent railway official of that time who had no sympathy with "lady help,"

wrote: "A trial of eight months at Warrington station has shown that there may be too much of civility and an evident desire to oblige men in a booking office of a railway station, and it has been once more demonstrated that the gentle nature of women has little affinity to unrelenting regulations founded on the principle of promptness, punctuality and despatch. Regardless of the fact that a train happened to be waiting at the station, conversation, no doubt of a pleasing and satisfactory character, would be continued in the ticket office, and while the machinery of the local line merged into inextricable confusion, flirtations stolen and therefore the more sweet, drowned all recollection of infuriated directors or the probability of accidents.

It would be needless to state, that to avoid some terrible calamity, the female clerks were politely but firmly requested to depart in search of a more congenial sphere of occupation, and that beings of a sterner mold were again installed on the onerous duties at Warrington station.

#### About the Drill Press.

The proper running of a drill press is a much more important job than it is generally believed to be. The idea that anybody can run a drill press is a mistake. Long experience and close observation is necessary to become familiar with speed limits and cutting angles and the lubrication of drills, not to speak of the numberless details of adjusting and clamping work. It is a noteworthy fact that on drilling work that is not clamped down on the table and where the stop point or holder against which the work is steadied, is to the left of the drill point, the tendency of the hole being drilled is to creep nearest the upright post of the machine. A few of the more experienced machinists know how to make allowance for this by drawing the center towards the outer side.

On a sloping surface the center of holes should be drawn to the higher side before the operation is begun, and it is very helpful on uneven surfaces to drill a small hole as a guide for a larger drill, which will run true to the smaller hole. In enlarging holes it is dangerous to attempt to enlarge a hole with a twist drill. Only the drills should be used in increasing the size of holes, that is, when there is only a small amount to cut off. In the case of a small hole merely intended as a central guide, a twist drill of a much larger diameter can be used effectively.

In regard to increasing the size of holes by the usual process of running a rose bit through, the work should not be clamped to the table until the rose bit has begun to work in its true center, otherwise it is very difficult to locate the true center, and the hole instead of being straightened may be completely spoiled. In drilling

holes for tapping there is usually a table showing the sizes of drills to be used for certain sizes of taps, but in addition to these it may be noted that in drilling for permanent screws or tap bolts that are not likely to be disturbed, a larger hole may be drilled than for operating screws where the thread must necessarily be full and perfect.

It may be added that the tendency of the present time in the principal machine shops is toward making jigs for every class of work where exact duplicates are required. The inclination to make jigs is the one distinguishing mark of the factory-bred mechanic. It gives a perfection of work that no mere careful watching can ever hope to rival. Jigs with hardened bushings pay for their construction in a very short time. There are no spoiled holes, no large holes to be tapped and plugged up and to be drilled again. There are no useless and wasteful reamings. Jigs are appliances that lead toward perfection in drill press work. In high class work jigs are not merely a convenience, they are a necessity. Sometimes they may seem trifling, but trifles make perfection, and perfection is not a trifle.

#### The Humble Youth's Opportunities.

A sad characteristic of Young America is the tendency to be ashamed of poverty and to make pretense of having been reared in the lap of luxury. The inspirations that move youths to energetic ambition to success in life do not emanate from the lap of luxury. In his very interesting *Life of James Watt*, Andrew Carnegie says: "The writer's knowledge of the usual effect of the heritage of millionaires upon the sons of millionaires leads him fully to concur with these authorities to believe that it is neither to the rich nor to the noble that human society has to look for its preservation and improvement, but to those who have to labor that they may live, and thus make a proper return for what they receive as working bees, not drones, in the social hive. Not from palace or castle, but from the cottage have come the needed leaders of our race, under whose guidance it is to ascend."

#### Soft Hammers.

Many soft hammers are soft only in name. Last century there were hammers made of lead and babbitt that were really soft and left no mark on polished metal. Now they are made of scrap copper or dross of bronze, or other indescribable compounds. Knuckles and corrugations gather on their wrinkled faces, and their impressions may be seen and felt all over the twentieth century locomotives. The polished crossheads are bruised and dented like the shield of Launcelot by the blows of circumstance. Valve rod ends and bolts and keys are battered out of

recognition. Even the piston glands bear sad traces of the unkindly thumps that they received. The chief point of attack, however, is the rod straps. The distressful strokes from which they suffer begin before the locomotive has left the shop. In coupling up the rods there is necessarily more or less experimenting with liners to adjust the rod to the exact distance as well as to secure the correct correlation of the bolt holes. The skilled mechanic who has ever fine-finished a rod strap knows that there is a silken softness on the surface of a finely finished strap, or other highly polished, unhardened metal. The rod man begins operations with a block of wood. The so-called soft hammer breaks the piece of wood into a thousand pieces, and there is no time to keep up the supply of timber, so it is that in the general hurry and confusion that invariably attends the finishing of a locomotive, the alleged soft hammer begins to get its work in.

In a few months the strap not only presents a very sorry appearance, but the mechanical effect of the blows has been such that the outer surface of the strap has become lengthened and the strap has closed in at the free ends, while the solid end has by repeated hammering become crystallized and is in a condition that is ready to break when the psychological moment arrives.

Hammers of lead or babbitt are comparatively harmless and are easily made. Small bars of lead are also very useful in adjusting the finer parts of a machine. The bar may be readily held upon the strap or key or bolt head, and a straight and effective blow can be struck on the leaden bar by the ordinary hand hammer. In any event the copper or bronze hammer should be reformed or abolished altogether. The element of durability, which is its distinguishing feature, is its worst feature. It hardens as it grows older. Its blows mar the hardest surfaces. Like the leprosy or the smallpox, its victims are known at a glance. Nothing on the modern locomotive seems free from the pernicious effects of the soft hammer from the brake hangers up to and including the boiler checks.

#### The Pernicious Effect of Alcoholic Beverages.

A young man who wished to hide his identity was drowned in an English river. On a paper found in his pocket was written: A wasted life sent to death by the curse of strong drink. Let me rot without inquiry. Within a week the coroner received over two hundred letters from anxious parents wishing for particulars about the drowned man so that they could decide if he was their lost son. Horrible tax that drink puts upon decent households.

## Pacific Type of Locomotive for the Delaware, Lackawanna & Western Railroad

The general idea that certain types of locomotives had reached the limit of their capacity in power has, during the past year, been repeatedly proved to be a fallacy. Five Pacific type locomotives, believed to be the most powerful of its kind, have recently been delivered to the Delaware, Lackawanna & Western Railroad Company by the American Locomotive Company.

The general introduction of steel cars in passenger service has necessitated the purchase of these heavier engines. They have been put in service between Scranton and Hoboken. This division crosses the Pocono mountains and has a constant ruling grade between Stroudsburg and Pocono Summit of 78 feet to the mile for a distance of 16 miles, with curves of 5 and 6 degrees. Trains of nine steel cars

increase in power of 16.4 per cent. was obtained.

A tractive power of 47,500 pounds on a Pacific type passenger locomotive requires an exceptional boiler. It is of the extended wagon top type. At the first course the barrel measures 79½ inches in diameter outside, while the outside diameter of the largest course is 88½ inches. The barrel is fitted with 272 tubes, 2 inches in diameter, and 38 flues, 5½ inches in diameter and 17 feet long. A combustion chamber 44 inches long is included. The firebox is 126⅞ inches long by 104¼ inches wide and includes a brick arch supported on 5 tubes. All longitudinal seams are dectuple riveted. Tube and flue heating surface is 3,311 sq. ft., firebox heating surface is 332 sq. ft., arch tube heating surface is 57 sq. ft., giving a total

the side of the steam dome. The throttle valve itself has a stem projecting downwardly through the throttle box. The passage through which the stem passes is made steam tight. At the lower end of the throttle stem there is a horizontal lever, one end of which connects through a vertical rod with the inner arm of the operating shaft on the side of the dome. The stuffing box on the side of the dome is of ordinary construction suitable for a rotating shaft. It will be noted that this shaft has a motion of rotation only and is not subject to the same objections as a backhead throttle rod which is pulled in and out of the stuffing box.

The throttle rod passes over the outside of the boiler jacket and in through the front of the cab, connecting to a special design of throttle lever. This throt-

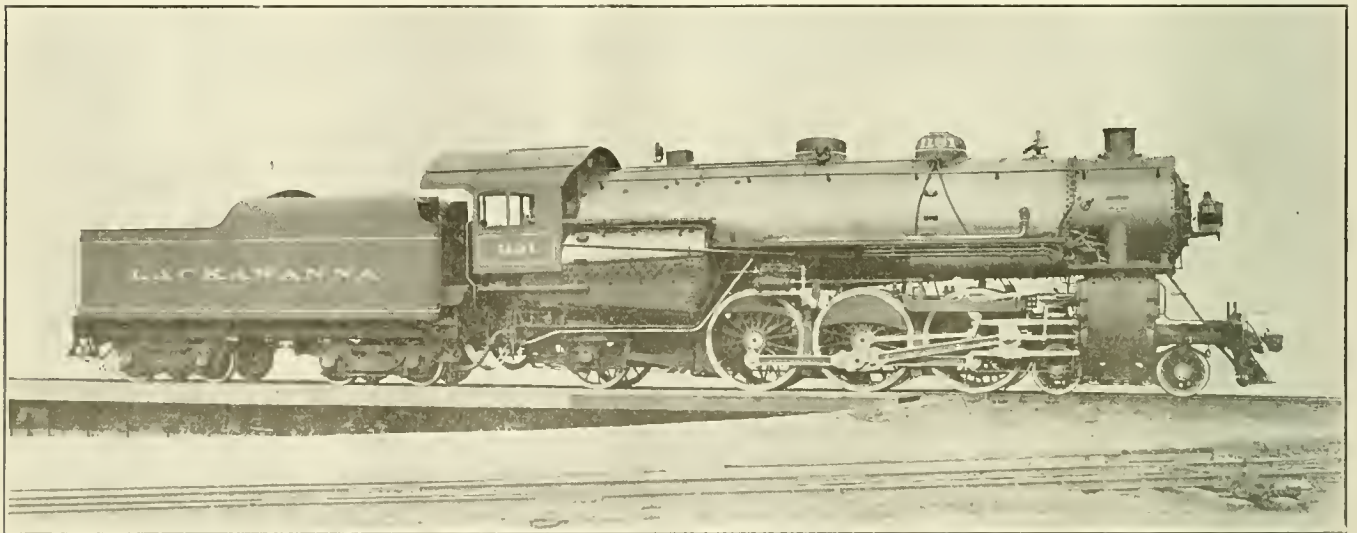

PACIFIC 4-6-1 TYPE OF LOCOMOTIVE FOR THE DELAWARE, LACKAWANNA & WESTERN RAILROAD.

H. C. Manchester, Supt. M. P. & E.

American Locomotive Company, Builders.

are being handled over this district on Lackawanna Limited trains Nos. 3 and 6, or a total train load of 600 tons, at a speed of 30 miles per hour. On other trains these engines are handling from one to two extra cars at schedule time on the grades. Also, all helpers on the mountain district have been dispensed with on trains consisting of ten cars or less.

Pacific type locomotives built three years ago and known as the 1101 class, which have been replaced by the new locomotives, handled 530 tons of train in eight cars at the same speed.

The new Pacifics have a total weight, engine and tender, of 471,300 pounds and a tractive power of 47,500 pounds. Pacifics of the 1106 class have a total weight, engine and tender, of 449,800 pounds and a tractive power of 40,800 pounds. With an increase in weight of 4.8 per cent. an

of 3,680 sq. ft. Superheating surface is 760 sq. ft. and grate surface is 91.3 sq. ft. One of the locomotives, number 1131, is fitted with a Riegel boiler. This boiler has the same tube, flue, and arch tube heating surface, superheating surface, and grate area. The firebox heating surface is reduced by 5 sq. ft. and 260 sq. ft. of water tube heating surface is added which gives it a total heating surface of 3,935 sq. ft. Baffle plates are installed along both sides of dome opening in boiler shell to prevent water washing up into dome when engines are rounding curves.

An interesting detail is the design of the throttle arrangement known as the Woodard throttle and patented by the builders. The throttle rod is placed on the outside of the boiler shell and operates the throttle by means of a horizontal shaft which passes through a stuffing box on

the lever is so arranged that it has a differential leverage. At the beginning of motion the leverage is greatest and the movement of the end of the lever is largest for a given motion of the throttle rod. The arrangement, therefore, offers a method of obtaining maximum pull at the beginning of the motion. After the throttle valve is unseated the leverage increases with a corresponding decrease in the travel of the lever handle for a given lift of the valve. This permits of using the throttle lever with which the travel in the cab can be kept down to workable limits and at the same time the starting pull obtained is sufficient to easily lift the valve. Also, the position of the throttle lever in the cab permits of a better arrangement of the backhead fittings on the boiler than can be obtained with the old style of throttle lever. The gauge cocks are un-

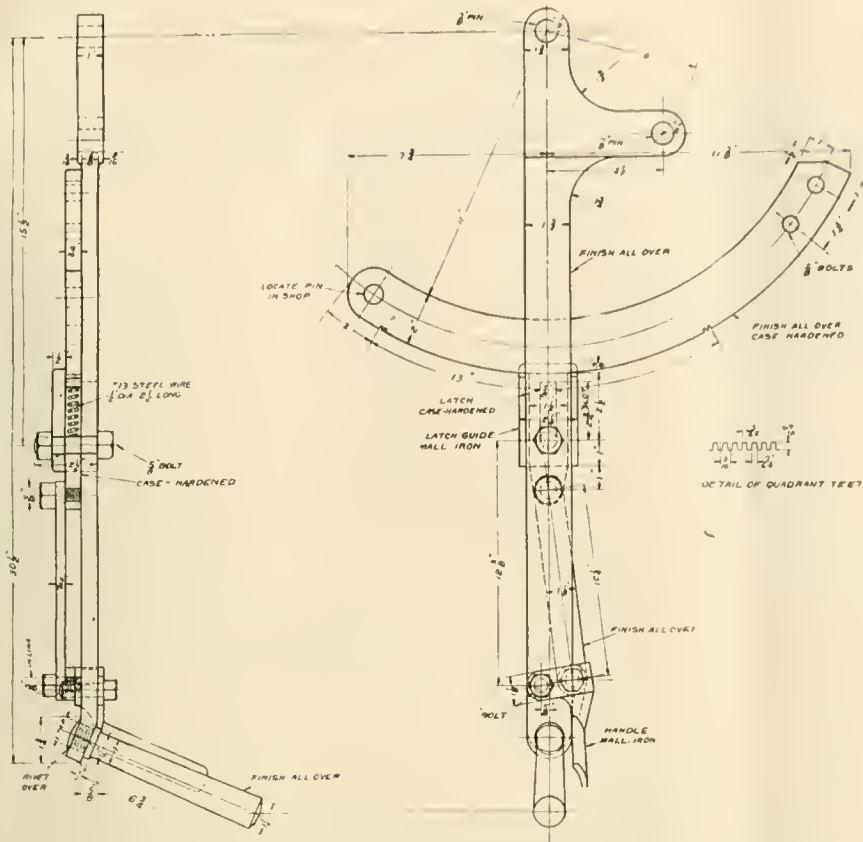

DETAILS OF WOODARD THROTTLE LEVER.

obstructed by the throttle lever handle, and the water glass and steam gauges can be placed in the position usually occupied by the throttle stuffing box and fittings of the lever.

All driving axles and main crank pins are of Cambria Coffin Process steel with a 3-inch hole bored the entire length after they have been given the Coffin Process. Other interesting details are Man-

chester-Riegel by-pass and drifting valves, Walschaerts' direct drive gear having the combination link attached to the crosshead wrist pin, Schmidt superheater, brick arch, Ragniet power reverse gear, Foulder solid back end main rod, Woodard inverted link constant resistance engine truck, Cole long main driving box, self-centering valve stem guide, extended piston rods, radial buffer, and vanadium frames.

The following are the general dimensions of this type of locomotives:

- Track gauge, 4 ft. 8 1/2 ins.
- Fuel, Anthracite coal.
- Cylinder, type, Piston; diameter, 27 ins.; stroke, 28 ins.
- Tractive power, simple, 47,500 lbs.
- Factor of adhesion, simple, 4.35.
- Wheel base—Driving, 13 ft. 0 in.; rigid, 13 ft. 0 in.; total, 34 ft. 5 ins.; total engine tender, 67 ft. 1 in.
- Weight—In working order, 305,500 lbs.; on drivers, 197,300 lbs.; on trailer, 56,000 lbs.; on engine truck, 52,200 lbs.; on engine and tender, 471,300 lbs.
- Boiler—Type, extended wagon top; O. D. first ring, 79 1/2 ins.; working pressure, 200 lbs.
- Firebox—Type, wide; length, 126 1/8 ins.; width, 104 1/4 ins.; combustion chamber, with length, 44 ins.; thickness of crown, 1/2 in.; tube, 9-16 in.; sides, 1/2 in.; back, 3/8 in.; water space front, 5 ins.; sides, 3 ins.; back, 4 ins.; depth (top of grade to center of lowest tube), 23 1/2 ins.
- Crown, staying, radial.
- Tubes—Material, char. iron; number, 272; diameter, 2 ins.

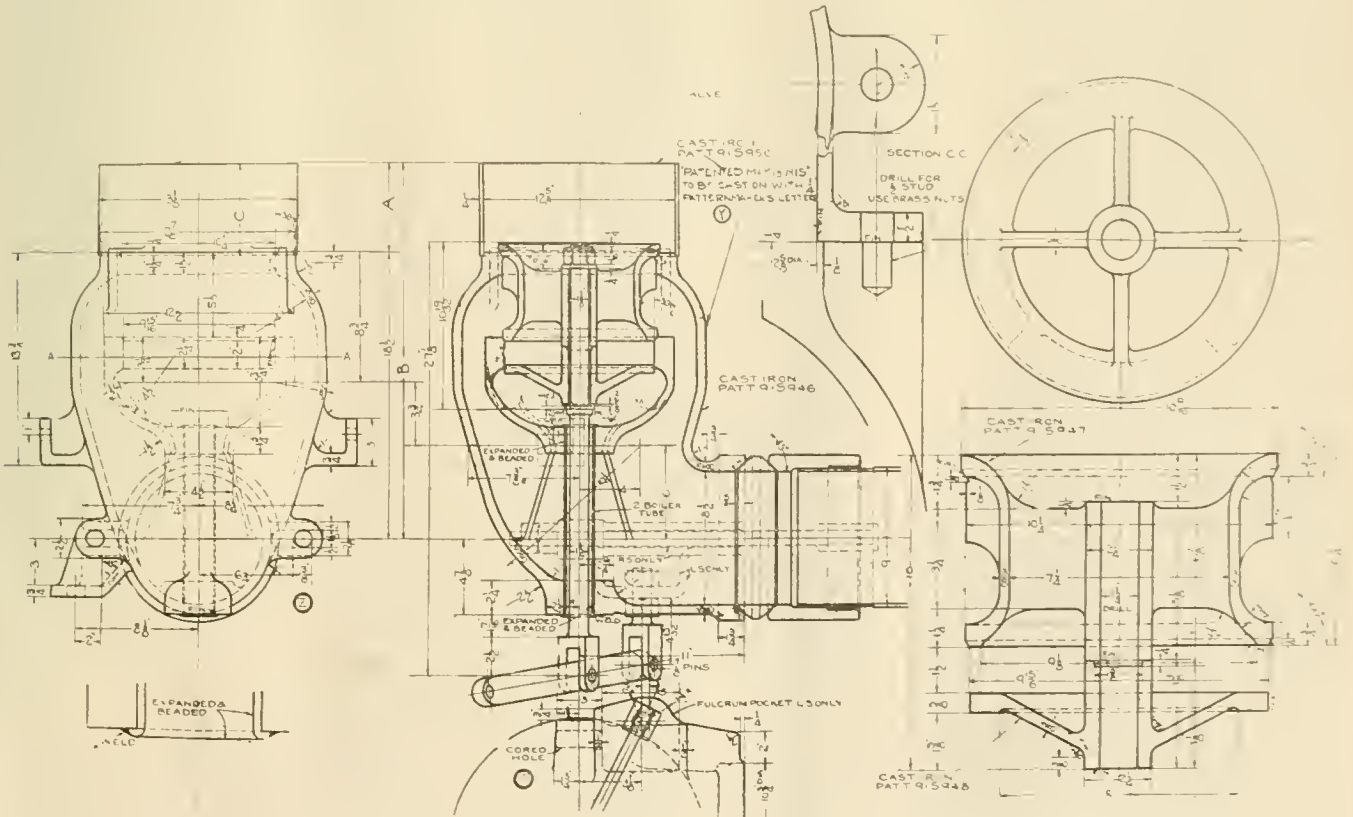

DETAILS OF THE WOODARD THROTTLE VALVE.

Flues—Material, hot rolled S. S.; number, 38; diameter,  $5\frac{3}{8}$  ins.  
 Thickness—Tubes, No. 11, B. W. G.; flues, No. 9, B. W. G.  
 Tube—Length, 17 ft. 0 in.; spacing, 11-16 in.  
 Heating surface—Tubes and flues, Riegel, 3,311 sq. ft.; firebox, Riegel, 327 sq. ft.; arch tubes, Riegel, 37 sq. ft.; water tubes, Riegel, 260 sq. ft.; total, 3,935 sq. ft., 3,680 sq. ft.  
 Superheater surface, 760 sq. ft.  
 Grate area, 91.3 sq. ft.  
 Wheels—Driving, diameter outside tire, 73 ins.; center diameter, 66 ins. Driving material, main, C. steel; others, C. steel. Engine truck, diameter, 33 ins.; kind, C. iron. Trailing truck, diameter, 50 ins.; kind, C. steel spoke. Tender truck, diameter, 36 ins.; kind, solid rolled steel.  
 Axles—Driving journals, main,  $11\frac{1}{2} \times 21$  ins.; other,  $10\frac{1}{2} \times 16$  ins. Engine truck journals,  $6\frac{1}{2} \times 12$  ins. Trailing truck journals,  $9 \times 14$  ins. Tender truck journals,  $6 \times 11$  ins.  
 Boxes—Driving, main, C. steel; others, C. steel.  
 Brake—Driver, American Wm-3 West. E. T. No. 6; truck, American; tender, West. E. T. No. 6; air signal, West. L.; pump, 1-11 in. West.; reservoir,  $218\frac{1}{2} \times 102$  ins.  
 Engine truck, 4-wheel Woodard.  
 Trailing truck, radial self-centering.  
 Exhaust pipe, double; nozzles,  $3\frac{7}{8}$  ins., 4 ins.,  $4\frac{1}{8}$  ins.  
 Grate, style, Rocking.  
 Piston, rod diameter,  $4\frac{3}{4}$  ins.; piston packing, G. iron ring.  
 Smoke stack, diameter,  $18\frac{1}{2}$  ins.; top above rail, 15 ft. 3 ins.  
 Tender frame, D. L. & W. style, 13-in. channels.  
 Tank—Style, Water Bottom; capacity, 9,000 gallons; capacity, fuel, 10 tons of coal.  
 Valves—Type, Piston, 14 ins.; travel,  $6\frac{1}{2}$  ins.; steam lap,  $1\frac{1}{8}$  ins.; ex. clear, 3-16 in.; setting, O in full gear forward, lead 9-16 in. in full gear back.

#### Wrought Iron and Steel Pipes.

From a long article contributed to the *Engineering Magazine* by L. C. Wilson, we glean the following:

In puddling, the iron is melted on a bed of iron ore which gives up part of its oxygen to oxidize the carbon, silicon, and manganese, and, to a less extent, the sulphur and phosphorus. The greater the purity of iron, the higher the temperature at which it melts; therefore, the metal in the furnace becomes pasty after a time as the impurities are burned out, and is worked into a ball and removed.

This ball is rolled into bars of convenient size, which are cut and piled up, then reheated to a welding temperature and

rolled again into a bar of the desired dimensions.

Wrought iron produced in this manner is a very pure article, the greatest and most objectionable part of the impurities being the slag, which is scattered all through the metal and gives it the apparently fibrous structure so characteristic of its appearance after rolling. These fine slag lines are easily detected and form a ready means of distinguishing between wrought iron and that produced by other methods. It is only necessary to smooth down a small spot with a file when the lines will show up; best, under a magnifying glass.

It can be seen that the puddling process is rather slow and expensive, since only a limited amount of metal, a few hundred pounds at most, can be treated at a time. Something like an hour and a half is required for a charge, and considerable skill and care are needed in order to obtain a good product. The presence of two per cent. or so of slag distributed irregularly throughout the mass can hardly tend to increase the homogeneity, and it is generally accepted that lack of this is of more importance, from the standpoint of corrosion, than the presence of a reasonable amount of impurities thoroughly and uniformly mixed in. It is very hard to weld perfect sheets or bars several inches in width, so laminations are met with and may give trouble.

In the Bessemer process, the molten iron from the blast furnace is run into huge mixers, then into big egg-shaped converters, where cold air is blown through the charge by means of tubes at the bottom. The entering oxygen rapidly burns out the impurities, and thereby generates a large amount of heat; so no difficulty is experienced in keeping the metal melted. The length of time the air is blown through is determined by the color of the flame issuing from the mouth of the converter. As might be expected, more or less of the iron is oxidized at the same time; but the addition of a small amount of manganese, for example, will take care of these oxides, so the requisite quantity of this, calculated from an analysis of the iron, is added together with such other elements as may be needed.

It requires only ten or fifteen minutes to convert as many tons of iron into an equal quantity of steel, so in point of speed and general economy the Bessemer process is superior to the other. It is especially adapted to making low carbon steel, and, as a matter of fact, gives a product which is more nearly pure, considered on the score of total impurities, than that from the puddling furnace. As a general proposition, the silicon, carbon, sulphur, manganese, and phosphorus may be lower in the wrought iron than in the steel, but the former will contain about two per cent. of oxides, while in steel

these will not run over one or two tenths of one per cent. From the nature of the process whatever impurities are present are well distributed, and as the metal is rolled directly into skelp, without cutting and re-welding, as in the case of wrought iron, the danger from laminations is greatly reduced.

Concerning the relative value of iron and steel an excellent authority says: Of ten different tests made by different observers, seven resulted distinctly in favor of steel, while in three cases the results were slightly in favor of iron. The tests that resulted in favor of steel were: seven months in hot aerated salt water; sixteen months buried in dampened ashes; exposed to sulphuric acid coal-mine water; in railroad interlocking and signal service; in locomotive boiler service. It was found that steel tubes made in 1906 fritted much less than those made in 1897 by the same makers, indicating the superiority of modern steel over that of a decade earlier.

#### The Taper Fit.

In locomotive work, the taper can be used to advantage in many places such as strap bolts for rods, bolts in guides, links, etc. In other places where it is desirable to get rid of heads of bolts, they could be let in flush with the surface, saving time and trouble in wiping, also getting rid of the dirt and oil which accumulate and looks so bad where cleanliness is desirable.

The taper is also much used in fitting crank pins, and in some places in fitting wheel tires and wheels on axles. As to making taper fits, it is a well-known fact that very few holes of any length are perfectly straight when made with a lathe; that is, where the work is held in a chuck or on a face plate. If a reamer is used, in almost every case the hole will be found larger on the front side, as can easily be seen by trying arbor at both ends. If the hole is turned out with a tool held in the rest, it will be found that most lathes are more or less imperfect in cutting straight. Where both centers are used, it can of course be made to cut straight by moving the tail center. In making a taper hole, if a ream is used, it must have some kind of a stop if more than one hole is to be made; the same if a hand reamer is used, it is likely to chatter, in which case the hole will not be round. In turning out a taper hole held in a chuck or on a face plate, the imperfections of the lathe must be taken into consideration, provided a certain taper per inch is to be used.

To perfectly fit a stud or shaft to a taper hole requires patience and care, especially where the work is large and heavy, so that it is not handy to try the bit frequently.



# Air Brake Department

## Charging Trains With E. T. Equipment—Type J Compressor Governors—Changes in Federal Regulations

In a previous issue we have attempted to point out the necessity for a brake inspection of the locomotive by the engineer, and if followed out a great deal of time may be saved when charging or attempting to maintain the required pressure in the brake pipe of a train of cars. In coupling to an uncharged train of cars it is well to make an effort to have a reduced pressure in the pressure chamber of the distributing valve before the air hose are connected, and this can be accomplished by making one or two heavy reductions in the brake pipe with the automatic brake valve and allowing the valve handle to remain on lap position while the hose are coupled. The object is to prevent any possible annoyance from the creeping on of the engine brake should a prompt movement of cars become necessary. It is understood that the brake can be released under any conditions with the independent brake valve, but the idea is to prevent an unnecessary application of the brake, which is a waste of main reservoir pressure which may be of material assistance in charging the train brakes. In handling modern trains of cars, economy in compressed air consumption should be practised to such an extent that it will become second nature, and this in itself will avoid a waste of time and delays.

As an example of the advantage that may be derived from coupling to a train of cars with the pressure chamber and the auxiliary reservoir pressures somewhat depleted, if coupled to several cars with the L. N. equipment, fully charged, and it is necessary to couple up to several more cars uncharged or partially charged, a 25 or 30 pound brake pipe reduction made after the cars are coupled and before the air hose are united, will prevent the possibility of an angle cock being used to produce an emergency application of the brakes and thus prevent a prompt release following an emergency or quick action application. This becomes apparent if we understand that the L. N. brake equipment if used in quick action develops approximately 105 pounds pressure in the brake cylinder, and in order to effect a release the brake pipe pressure must be raised to at least 106½ or 107 pounds, whereas if the brake is applied with the heavy service reduction when coupled, the brake cylinders will contain too high an air pressure to permit of the operation of the by-pass valve of the triple valves and the brake cannot be

thrown into quick action and develop the high brake cylinder and auxiliary reservoir pressure which interferes with the prompt release of brakes, but instead the brake may be released somewhat sooner and the auxiliary reservoir recharged from the supplementary, requiring only enough main reservoir volume to raise the pressure in the pipe under the cars. Also, the service brake pipe reduction with the brake held on while the hose are being coupled will necessitate leaving the brake valve handle on lap position which will permit the compressors to accumulate the maximum pressure in the main reservoirs to the intent that this may be used to facilitate a prompt release and recharge of brakes.

In handling the modern, L. N., P. C. and U. C. brake equipments, this will be found of considerable importance as the volume of compressed air stored in these equipments ranges from ten to sixteen cubic feet each, that is, the capacity of the various reservoirs and the brake pipe is about five times that of the P. M. equipments which range from two to four cubic feet in capacity to hold compressed air, therefore in volume, the one car with the modern equipment is equal to at least five cars of the P. M. type, or a 10 car train of modern brake equipment stores a volume of compressed air equal to a train of fifty cars of standard high-speed brake equipment, but when charged and correctly manipulated the release is much more positive with modern brakes than with the former high-speed type. In service operation, the improved action during a release is due to the auxiliary reservoirs being recharged from the supplementary, quick recharge or emergency reservoirs, as the case may be, but after the emergency or quick action application the release is more difficult with modern equipment principally because the brakes were designed to develop high brake cylinder pressures for emergency stops, the release action being in some considered of secondary importance. To just what figure it is necessary to raise the brake pipe pressure in order to effect a release depends upon the type of equipment used and the relative sizes of the storage reservoirs. We have stated why the L. N. brake is more difficult to release after an emergency application, and if the P. C. brake is used a full emergency brake cylinder pressure will be 86 pounds, requiring approximately 88 pounds brake pipe pressure for a release. The U. C. with the large emer-

gency reservoir for high pressure develops about the same brake cylinder pressure as the L. N. equipment, but through a separation of brake cylinder and service and auxiliary reservoir pressure, 90 pounds in the brake pipe will produce a release. Contrasted with this is the P. M. brake, which blows the auxiliary reservoir pressure down to 60 pounds during a quick action or emergency application.

However, this digression from the subject is merely to set forth the fact that prompt movements of cars under the various conditions is made possible through the practice of economy in compressed air consumption and the maintenance of the maximum pressure in the main reservoir.

In charging a train of cars, there are various reasons why release position of the brake valve should be used and one reason in particular why it must be used. If the brake valve handle is brought to running position while charging a train, the compressors may be expected to stop through the action of the excess pressure pump governor top, because if the storage reservoirs on the cars absorb brake pipe pressure faster than the main reservoir pressure can expand through the feed valve, which with a long train is always the case, the difference in these pressures unseat the diaphragm valve of the excess pressure governor top and stop the compressors until the main reservoir pressure reduces to a figure within 20 pounds of that remaining in the brake pipe. This is, of course, prevented by using the brake valve handle in release, the correct position for charging the brakes on cars.

When the brake pipe pressure is then very nearly up to the adjustment of the brake pipe feed valve, the valve handle must be moved to running position to prevent an overcharge of brakes, and the compressors then cannot be stopped by a 20 pound difference between the main reservoirs and the brake pipe until the desired pressure has accumulated.

Ordinarily then the stoppage of the compressors may be expected if the brake valve handle is brought to running position while the car reservoirs are being charged, but after waiting a reasonable length of time for the charging to be completed it may be found that the pump or compressors stop every time the valve handle is brought to running position, and it may be due to the brake pipe leakage being in excess of the capacity

of the feed valve, or to state it differently, the capacity of the feed valve may be insufficient to supply the leakage present in the brake pipe. Brake pipe leakage can be determined by making a brake pipe reduction, returning the valve handle to lap position and noting the fall of pressure as shown by the black hand of the small air gage, but a test for the capacity of the feed valve would involve cutting the air hose between the engine and tender and noting the rate at which the main reservoir pressure will escape with the handle in running position and the angle cock at the rear of the tender open.

In order to make a test for the capacity of the feed valve to deliver main reservoir pressure, the pressure should be allowed to pump up to standard, then by closing the brake valve cut out cock and opening the angle cock at the rear of the tender and having the driver brake released by means of the independent valve, the brake valve cut out cock may be opened, and with the automatic brake

from 30 to 35 seconds. With the smaller reservoirs of about 50,000 cubic inches the drop from 130 to 110 pounds will be in from 15 to 20 seconds, and with exceptionally small reservoirs of say 35,000 cubic inches, in about 10 seconds time.

This is based upon the assumption that the feed valve is working at its maximum capacity and that there is no restriction in the feed valve or in the piping. However, if the time required to reduce the main reservoir pressure is considerably longer than the time given for a drop of 20 pounds pressure in the average size of main reservoir, it will indicate that there is a restriction in the feed valve or the piping, and if it is then found that the excess pressure top of the governor will not hold the compressor shut down it indicates that the restriction is not in the feed valve or the piping leading to it, but rather that the feed valve pipe pressure is being maintained and that the restriction is in the feed valve pipe or brake pipe passages in the

would be consumed in cleaning the feed valve, for cleaning could not be expected to remove a restriction in the ports in the valve or in the piping, and there are several reasons why the train should not be run over the road with the brake valve in full release position.

If, however, the brakes have been tested according to standard instructions and the train has been pulled out of the yard, brakes may be felt to be dragging and it is then permissible to make a quick movement to release and back to running position for the purpose of "kicking off" any brakes that may have stuck from any temporary irregularity, but such movements should never be made at any other time than when brakes are felt to be sticking, because such movements, if continued, tend to overcharge the brake pipe and produce stuck brakes.

If when moving a train it is found that the compressor has stopped for an unusual length of time, the positions of the gage hands should be observed, and if the

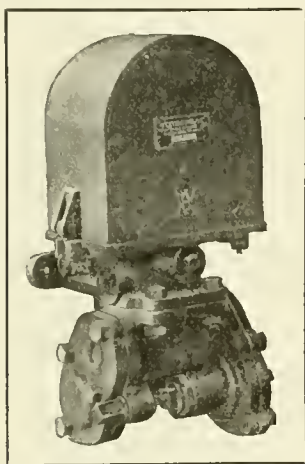

FIG. 1.—TYPE OF ELECTRIC COMPRESSED MOTOR.

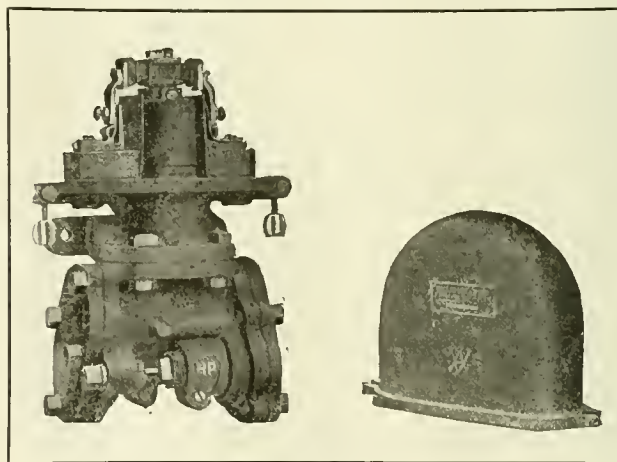

FIG. 2.—GOVERNOR WITH COVER REMOVED.

valve in running position, the fall of the main reservoir pressure as indicated by the air gage will show the capacity of the feed valve to admit pressure from the main reservoir to the brake pipe.

This, in itself, is a very poor and unsatisfactory test if the man conducting it has no idea of the capacity of the main reservoir on the locomotive he is handling, and it is practically impossible to make an accurate estimate of the volume of compressed air that is escaping without knowing the temperature of the compressed air in the reservoir and the amount of moisture contained, but it is a very good test if the reservoirs are known to be free of water and if the man making the test has an idea of their capacity in cubic inches.

With the 60,000 to 80,000 cubic inch reservoirs found on modern locomotives, the drop in main reservoir pressure under the condition mentioned may be expected to be from 130 pounds to 110 pounds in from 20 to 25 seconds, or if in freight service from 90 to 70 pounds in

brake valve or in the brake pipe proper.

Under circumstances of this kind there are several wrong ways in which the compressors may be started and kept running, but the correct method of procedure would be to first make the brake pipe leakage test, then if the brake fails to pass this feed valve capacity test, take the engine back to the shop, granted there are no instructions that refuse to accept a defect of the feed valve as an engine failure. In case the return of the engine would be forbidden, the brake valve should be moved to release position during the feed valve capacity test and if the main reservoir pressure then drops rapidly with a heavy blow of air through the open hose at the rear end of the tender, the valve handle may be used partially in release position to maintain the pressure in the brake pipe until such time as the necessary repairs can be made.

The reason for taking an engine back to the shop in the event that a restriction is indicated in the feed valve test is to prevent an unnecessary loss in time that

hands of the large gage are more than 20 lbs. apart and the brake pipe gage hand somewhat below the point of feed valve adjustment, it would indicate that the stoppage was due to some irregularity of the feed valve. If the valve handle was then moved to release position and the compressors would not start, it would indicate that the feed valve was stuck shut. Under these conditions it will be understood that the reason the compressors will not start is that with the brake valve in release position the feed valve pipe will receive no air pressure through the brake valve rotary and with the feed valve stuck shut the diaphragm valve of the excess pressure governor top will remain unseated and hold the governor steam valve closed.

Under this condition the brake valve would be moved far enough toward release position to partly open the brake valve warning port and in this position the feed valve pipe will be supplied from the main reservoir, and by observing the air gage, the brake valve handle can be regu-

lated to a position where the brake pipe pressure will be maintained without carrying the valve handle in full release position.

If, however, the movement of the brake valve handle to release position results in a lowering of main reservoir pressure and an increase in brake pipe pressure until the gage hands are somewhat less than 20 lbs. apart, and the compressors will not start, it will indicate that the pump governor is at fault or that the compressor has broken down. If two compressors are used the fault will be found in the governor, as it is scarcely possible for

brake valve handle in any position it would indicate that the maximum governor top was at fault or that the compressor had broken down and it would be necessary to proceed as previously outlined under the heading of pump and governor troubles.

**Type J Compressor Governors.**

In a recent issue the operation of a well known type of Westinghouse electric air compressor was explained, and as it was pointed out at the time, some means must necessarily be devised for controlling the operation of the compressor, that is, it

steam compressor governors. Instead of cutting off a supply of steam pressure the work of this governor is to disconnect an electric switch for stopping the compressor and to re-connect or to make another contact for starting the compressor. This switch is opened and closed through means of a piston and rod working through an air cylinder, the arrangement of which and the cut out details afford a pneumatic blow out of the arc so effectual that coils for a magnetic blow out or complete cut-off of current is unnecessary.

The electric portion is shown at the upper end of the cut of this governor and is

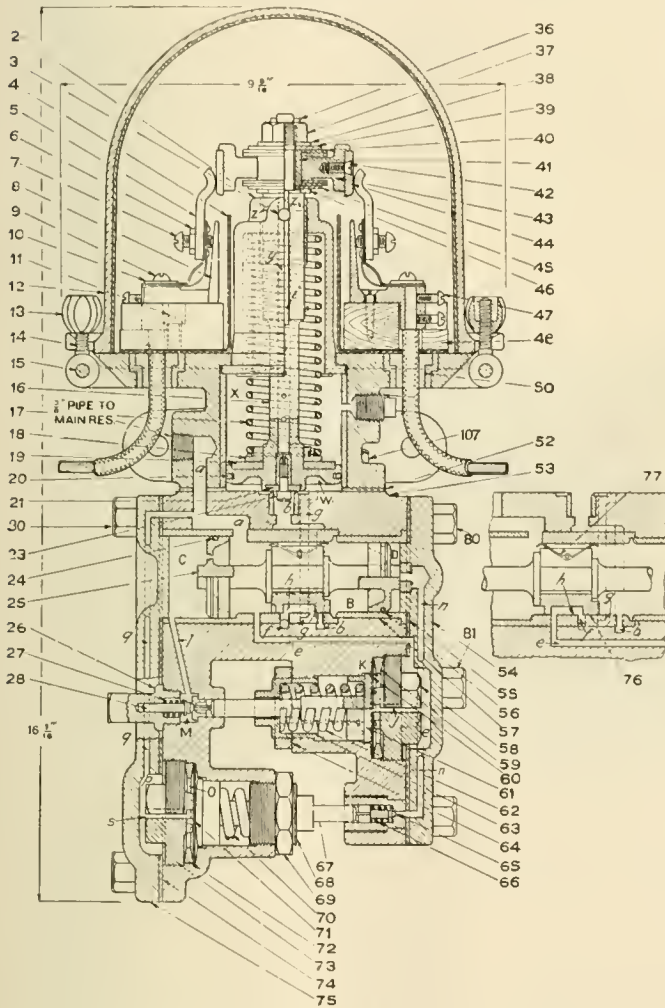

FIG. 3. DIAGRAMMATIC VIEW OF TYPE J GOVERNOR.

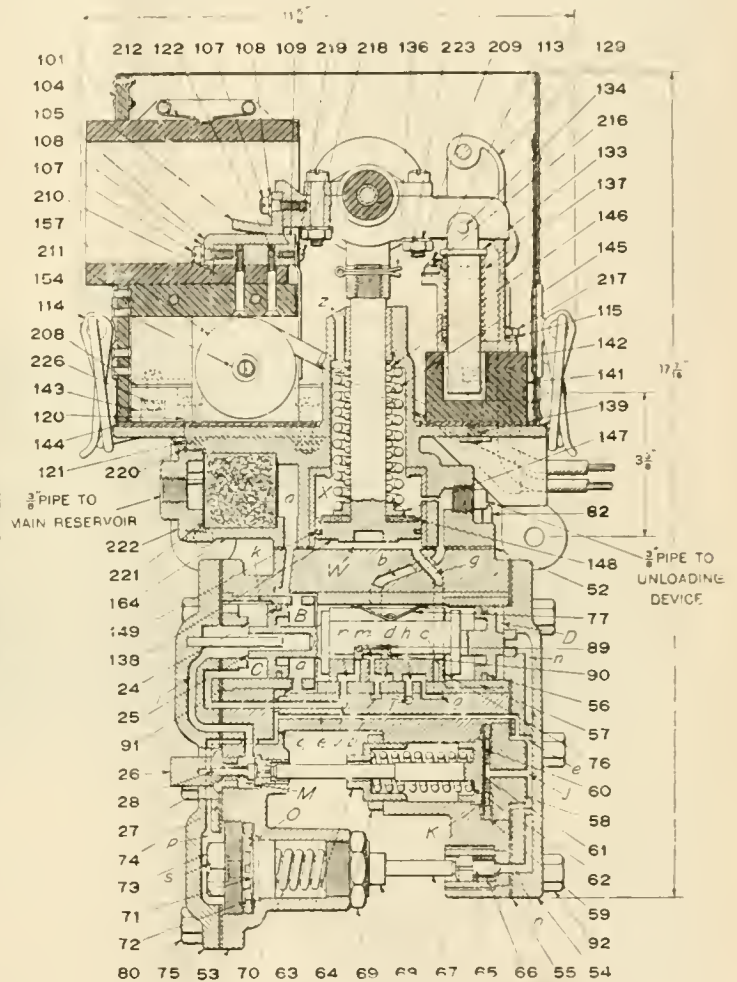

FIG. 4. J-23 COMPRESSOR GOVERNOR USING A MAGNETIC BLOW-OUT OF ARC.

both compressors to break down at the same instant. Under such a condition the brake valve would be placed on lap position to cut the air pressure from the main reservoir away from the excess pressure governor top, then if the compressors started when the handle was placed on lap position and stopped as soon as the handle was returned to running position, the gage hands still being less than 20 lbs. apart, the excess pressure governor is at fault and the handle can be held on lap long enough to place a blind gasket in the operating pipe.

Assuming the same condition, if the compressors would not start with the

must be stopped when the desired pressure has accumulated in the main reservoir and again be permitted to start when the pressure has fallen to a predetermined figure, and for this an electric governor is used.

The most familiar one of these is known as the type J governor, the electric portion of which can be modified or adapted to a variety of conditions as to voltage and current but we will deal chiefly with the pneumatic or regulating portion which will serve to indicate the requirements of a governor for an electric compressor.

The operation of the governor is necessarily different from that of ordinary

thoroughly insulated from the parts with which it comes in contact. In the diagrammatic view, Fig. 3, this governor is in cut-in position, the double piston and slide valve is operated by the opening and closing of small regulating valves resting against the diaphragm spindles which are moved by air and spring pressure acting on the diaphragms. The slide valve admits air pressure to, and exhausts it from, the space W in the piston cylinder.

The upper diaphragms, spring and spindle are the cutting out portion and the lower ones, the cutting in. When the compressor is started, main reservoir pressure enters as indicated and flows to

the double piston chamber between the pistons and equalizes through a small port with chamber C at the outside of the large piston, and it is also effective on the diaphragms of both the cutting in and cutting out portion. At this time regulating valve 28 is closed and valve 65 is open, and a glance at the diagram will show that this would hold the outside of the small end of the double piston open to the atmosphere, insuring that this position of the double piston and slide valve will be maintained.

When main reservoir pressure passes the cutting in point which is represented by the tension of spring 70, this spring will compress or yield, and close valve 65. Pressure is then equalized on all sides of the double piston and as the main reservoir pressure continues to rise until it reaches the cutting out point, which is the tension of spring 62, this spring will be compressed and the diaphragm spindle will unseat valve 28 and exhaust the pressure from chamber C, whereupon the pressure effective upon the inside of the large piston end will move this structure to the left or cut-out position, in which the slide valve admits main reservoir pressure to chamber W; but owing to a seal and the small portion of the piston exposed, this piston does not move at once, but when sufficient pressure to start it has accumulated, full pressure is effective on its entire area and it rapidly travels the full stroke through the cylinder, disconnecting the switch at the end of the rod and the sharp exhaust of the atmosphere from the space above the piston across the ends of the contact fingers accomplishes a complete pneumatic blow-out the instant the circuit is broken.

The double piston and slide valve remain in this position until main reservoir pressure falls below the cutting in point, the tension of spring 70, when the spindle draws away from spring 65 allowing spring 66 to unseat it and exhaust the pressure from the outside end of the small end of the double piston, the pressure surrounding the large end being equal, the balance of pressure effective on the inside of the small end of the piston moves the structure to the right, as shown, when the slide valve exhausts the pressure from chamber W, and the coil spring forces piston 16 and attached circuit closer back to the position shown where they remain until again cut out by the increase of pressure from the compressor, as explained.

It is important that the adjustment of this governor be thoroughly understood, the cutting out portion should be regulated first, the cutting in feature afterward and the cutting out regulation must be somewhat higher than the cutting in, the amount of difference to be decided by the requirements of service. The adjustment is made by means of regulating nuts, which form the abutments for

springs 62 and 70, and if the tension of spring 62 should be less than that of spring 70, the governor once cut out will continue to cut in and out in rapid succession without giving the desired results.

#### Changes in Federal Regulations.

In the November issue we printed the Federal Regulations governing the inspection and maintenance of locomotive brake equipment, and at the same time called attention to the fact that the same rules were subject to a slight revision, and the order of the Interstate Commerce Commission under date of October 11, 1915, changes but two of the paragraphs from those printed in our November issue, they are as follows:

**Compressors.**—The compressor or compressors shall be tested for capacity by orifice test as often as conditions may require, but not less frequently than once each three months.

The diameter of orifice, speed of compressor, and the air pressure to be maintained for compressors in common use are given in the following table.

Make.	Size compressor.	Single strokes per minute.	Diameter of orifice.	Air pressure maintained.
Westinghouse	9½	120	11/64	60
Westinghouse	11	100	3/16	60
Westinghouse	8½ CC	100	9/32	60
New York...	2a	120	5/32	60
New York...	6a	100	13/64	60
New York...	5b	100	15/64	60

This table shall be used for altitudes to and including 1,000 feet. For altitudes over 1,000 feet the speed of the compressor may be increased 5 single strokes per minute for each 1,000 feet increase in altitude.

**Brake Cylinder Leakage.**—With a full service application from maximum brake pipe pressure, and with communication to the brake cylinders closed, the brakes on the locomotive and tender shall remain applied not less than 5 minutes.

With these changes the rules stand as formerly printed, and we would call attention to a paragraph of the order which reads:

"It is ordered, that the said rules and instructions for the inspection of locomotives and tenders and all their parts, as follows, be, and the same are hereby, approved, and from and after the 1st day of January, 1916, shall be observed by each and every common carrier subject to the provisions of the act of Congress aforesaid as the minimum requirements: Provided, That nothing herein contained shall be construed as prohibiting any carrier from enforcing additional rules and instructions not inconsistent with the foregoing, tending to a greater degree of precaution against accidents.

#### Coal Reserves in the United States.

By the annual report of the Secretary of the Interior it appears that although we are the largest consumer of coal in the world, using nearly 40 per cent. of the world's production, we have as yet consumed but one-half of 1 per cent. of the total quantity the geologists estimate as present in the United States. The annual production of coal in the United States has increased over 800 per cent. in 35 years—from 68,000,000 short tons in 1879 to 570,000,000 short tons in 1913. The total value at the mines of the coal produced in 1913 was \$760,000,000.

The public-land States in the West contain the largest reserve of bituminous coal, both high and low grade, and of lignite in the world. Nearly half of this reserve is yet in public ownership. In the public-land States it is estimated that there are 100,000,000,000 recoverable tons of bituminous coal and lignite in beds of sufficient thickness and near enough to the surface to be profitably mined under present commercial conditions and many times that amount in thinner beds and at greater depths that can not be profitably mined at present.

So great is our use of coal and so large is our annual coal bill that consumers are constantly striving to obtain the largest measure of heat possible from their coal. This is being accomplished by the development of improved boilers and furnaces which permit the use of lower-grade coal, by the use of producer gas, and by the use of powdered fuel. The progress made in the use of coal in the last five years along mechanical and metallurgical lines is nothing short of remarkable.

If need be, the United States can supply the world with coal. The supply of coal is here, and undoubtedly the capital, labor, and transportation facilities will be forthcoming if the price of coal rises sufficiently to warrant their use for this purpose. But it is to be hoped that the great bulk of our coal will be utilized at home in the upbuilding of our industries. The apparent limitless extent of our coal reserves has made us prodigal in our waste of them. Coal is cheap in this country, and not until we put a higher value on it will proper attention be paid to its conservation in the ground. During each year for every 500,000,000 tons of coal produced we waste or leave underground in such condition that it probably will not be recovered in the future at least 250,000,000 tons of coal. This represents an average recovery of 66 per cent. In some cases the recovery in former years has not exceeded 30 per cent. of the contents. However, under the best current practice with improved mining methods some mines are now recovering 85 to 90 per cent. and the improvements in this regard are still going on with every assurance of still greater saving.

# Vanadium—Its Discovery and Qualities; Most Powerful Metal for Alloying Steel

The growing use of vanadium in locomotive construction gives occasional rise to the question among the younger railroad men, and others not so young, as to the discovery and qualities of vanadium. Its discovery in some of the lead ores in Mexico over one hundred years ago was discredited until a Swedish chemist named Sefstrom rediscovered it in 1830 in some remarkably ductile iron made from one of the Swedish ores. After a thorough analysis of the new material it was named vanadium, after Vanadis, one of the goddesses of Swedish mythology. Practically nothing came of the discovery for over half a century owing to the scarcity of the metal. In 1896 three armor plates were made in France in which vanadium was used. The tests of these plates showed a very remarkable improvement, and rapid investigations followed and the elastic limit of steel was found to be raised from 50 to 100 per

are still in service and have never failed. The result is that they are rapidly becoming standard on all of the leading railroads. Failures of vanadium frames have been less than one half of one per cent. from all causes. When it is considered that frame failures constituted at least 20 per cent. of locomotive maintenance a few years ago, it will be readily seen of what vast significance the use of vanadium is in locomotive frame construction. Probably the most remarkable proof has been shown in the case of the Southern railway, where the locomotive frames have practically been of vanadium steel for seven or eight years. Their records show that in six years there have been only three failures, two of which were caused by failure of other parts of the locomotives.

The accompanying illustration shows one of twelve sets of vanadium cast-steel frames made by the Union Casting Com-

### PHYSICAL PROPERTIES (Minimum)

	Grade A	*Grade B
Elastic Limit, lbs. per sq. in.	30,000	31,000
Tensile Strength, lbs. per sq. in.	65,000	75,000
Elongation in 2 in., per cent.	20	11
Reduction of Area, per cent.	28	27

\*When high carbon steel frames are specified this grade shall be used.

It is possible to obtain elastic limits of 40,000 to 45,000 lbs. per sq. in. with Grade B, commonly known as "high" or "40 carbon" cast-steel frames; but these high elastic limits are accompanied by low ductility, generally the minimum specified. This means greatly lessened resistance to shocks and repeated stresses and increased liability to failure through fatigue. On the other hand, the high elastic limits associated with high ductility of vanadium frames mean greatly increased resistance to fatigue or what is commonly known as crystallization, and much longer service.

The New York, Ontario & Western has



VANADIUM CAST STEEL FRAME FOR NEW YORK, ONTARIO & WESTERN, 2-10-3 TYPE LOCOMOTIVE  
Union Steel Casting Co., Makers.

cent. by the admixture of vanadium. Drills made from some of this steel containing three-tenths of one per cent. of vanadium proved to be 25 per cent. better than a 3 per cent. tungsten tool steel. According to eminent authorities vanadium is the element which, together with carbon, acts with the greatest intensity in the way of improving alloys of iron, and is undoubtedly the most powerful metal yet discovered for alloying steel.

Just as its superlative merits became thoroughly established, adventurous spirits were not slow in looking for the rare substance in the far ends of the earth. In the Andes in Peru an immense deposit of vanadium ore of richness and character hitherto unknown was discovered, and it is now available as a steel-making metal in unlimited quantities.

The first application of vanadium for locomotive construction was for frames. A number of Vanadium cast-steel frames were applied early in 1907, and all of them

pany for heavy Santa Fe type locomotives recently built for the New York, Ontario & Western. These are the largest and heaviest cast-steel frames of which the makers have record. They are 6 in. wide, 41 ft. 7 in. long, and each casting weighs 13,250 lbs.

The following are the average physical properties:

Elastic Limit, lbs. per sq. in.	47,000
Tensile Strength, lbs. per sq. in.	78,500
Elongation in 2 in., per cent.	26
Reduction of Area, per cent.	49

Contrast these high physical properties obtained by means of vanadium, with steel containing only .22% to .25% of carbon, with the Master Mechanics Association's latest proposed specifications for cast-steel frames as follows:

### CHEMICAL COMPOSITION.

	Grade A	*Grade B
Carbon	0.25%—0.37%	0.37%—0.50%
Manganese	0.40%—0.75%	0.40%—0.75%
Phosphorus	not over 0.05%	not over 0.05%
Sulphur	not over 0.05%	not over 0.05%

had over four years' experience with vanadium cast-steel frames which has proved to the mechanical officials the superiority of this type of frame and led to the specification of the particular frames recently ordered.

It may be added that special tests repeatedly made of carbon-vanadium steel, the chemical composition showed carbon .47 per cent., manganese .90 per cent., phosphorus .015 per cent., sulphur .020 per cent., and vanadium .15 per cent. the elastic limit has reached 118,500 lbs. per square inch, the tensile strength 142,300 lbs. per square inch, elongation in 2 in. per cent., 22, and reduction of area per cent., 34. These figures are not approached by any other kind of steel manufactured, and, as is well known, it is seldom indeed that one-half of these figures are surpassed in actual tests.

It need hardly be added that the use of vanadium is growing rapidly, particularly in automobiles and other machines.

# Electrical Department

## The Logan Division of the Ogden, Logan and Idaho Railway Equipped with High-Voltage, Direct-Current Electric Power

The Logan division of the Ogden, Logan and Idaho Railway is being equipped with one of the latest high-voltage direct-current electric power. Last spring the construction was completed on this section, known as the Cache Valley Route, and regular service has been inaugurated between Preston and Idaho and Wellsville, Utah, a distance of forty miles. This is the first interstate electric interurban road in that section of the Middle West.

The Ogden, Logan and Idaho Railway Company also owns and operates electric interurban lines from Ogden to Plain City, Utah; from Ogden to Brigham City, Utah; and from Ogden to the Hermitage and Idlewild resorts in Ogden Canyon east of Ogden and now constructing five miles from Idlewild to Huntsville. These latter lines were for-

The line from Preston to Wellsville traverses the eastern side of the rich Cache Valley in Utah, one of the state's finest and most beautiful sections. It is in direct competition with the Oregon Short Line, a steam road whose line is paralleled from Wellsville to Preston. The new line has been splendidly constructed in every detail. It has been carefully designed for high speed and heavy service, all grades being reduced as much as possible and short curves eliminated. The tracks are on a private right-of-way the entire distance, this right-of-way averaging 65 feet in width. Seventy-pound rails and catenary overhead construction have been used throughout.

The company secures its power from the Utah Power and Light Company's system, consisting of hydro-electric plants

equipment consists of one set of type "A" electrolytic lightning arresters and a type "GB" 3 pole, single-throw, hand operated automatic oil circuit-breaker. The high tension bus-bars are constructed of  $\frac{7}{8}$  inch copper tubing, and are provided with a full set of disconnecting switches. Power is measured on the high-tension side through 44,000 volt current and voltage transformers, the measuring instruments of both the Utah Power & Light Company and the Ogden, Logan & Idaho Railway Company being mounted on the low-tension switchboard.

Over thirty miles of the Logan division has been in operation for several months, a two-hour schedule being maintained. Three new all-steel triple compartment interurban cars have recently been placed in operation over this section of the line, running from Wellsville north to Lewis-

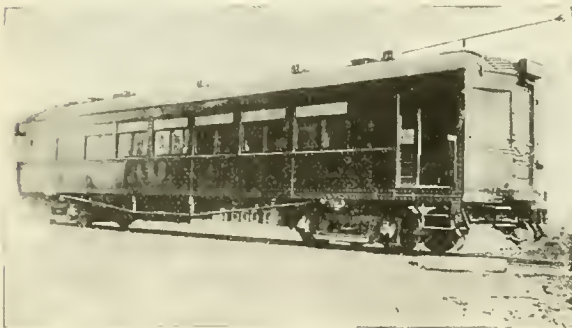

TYPE OF ALL STEEL CAR IN SERVICE ON THE LOGAN DIVISION OF THE OGDEN, LOGAN AND IDAHO RAILWAY.



ELECTRIC LOCOMOTIVE NO. 901.

merely owned by the Ogden Rapid Transit Company.

The City lines of Logan, Utah, together with a short interurban from Logan to Providence, a distance of two miles, were owned by the Logan Rapid Transit Company. The interests controlling the Ogden and Logan lines were friendly, and several months ago the properties were consolidated under the ownership of the Ogden, Logan and Idaho Railway Company, with general offices in the Eccles Building at Ogden, Utah.

The Ogden, Logan & Idaho Railway contemplates the construction this year of an extension from Brigham City to Wellsville, Utah. This connecting link will give this company a continuous interurban road running from Preston, Idaho, south through Utah to Ogden City,

with an aggregate capacity of 75,000 kva. and a 20,000 kva. steam auxiliary. This power is received at each of the substations of the Ogden, Logan and Idaho Railway from the Utah Power and Light Company's 44,000 volt transmission lines.

The transmission line voltage is stepped down by a bank of three Westinghouse 235 kva. single-phase, 60 cycle, oil insulated, self-cooled transformers to a potential of 2,300 volts. Both primary and secondary windings are connected in delta, and taps are provided for obtaining reduced voltage at starting. The particular capacity and arrangement of the transformers were selected with a view to operation in open delta in case of damage to one of the three units.

The protective apparatus and switching

ton. The new cars were built by the American Car Company of St. Louis. They are 62 feet in length over all, and have a seating capacity of 75 passengers. The electrical equipment on cars consists of four Westinghouse No. 334-E-6, 750-1500 volt motors, each with a nominal rating of 85 kw. On the higher voltage the motors are operated in series so that there is but a potential of 750 volts across each motor. They are geared for free running speed of from 47 to 50 miles per hour on the level, with an average of 1350 volts on the trolley.

The air-brake equipment on these cars consists of Westinghouse AMM apparatus with M-24-A brake valve combination straight and automatic air-brakes. A unique feature of the electro-pneumatic equipment on these cars is the use of a

continuously running dynamotor to furnish 750 volts power for the control and lighting circuits, and also to operate the air compressor. The compressor is connected mechanically to the dynamotor by means of a multiple disc clutch, which is normally held by a spring in a closed position. Whenever the air pressure reaches a predetermined value, the operation of the governor admits air to a small cylinder which disconnects the clutch and stops the compressor, but allows the dynamotor to continue running. The lighting equipment for the cars consists of two circuits of seven-56-watt Westinghouse Tungsten lamps with Alba shades, taking power from the dynamotor circuits. Headlights and heaters operate direct on the 1500-volt circuit.

To accommodate the local traffic in the city of Logan, the present four-motor, double truck, 40 passenger cars have been changed over to operate with straight 1500 volt equipment. Each car is equipped with two Westinghouse No. 543-A-6, 750-1500 volt motors, connected permanently in series and controlled by R-200 double-end equipment.

A 50-ton Baldwin-Westinghouse locomotive for hauling freight on the lines between Wellsville and Preston has recently been put in operation. The employment of the equalized pedestal form of construction on this machine allows the use of simply-designed trucks, with half-elliptic springs and rigid bolsters.

The tractive effort developed by the rotors, mounted in pairs on the trucks, is transmitted to the couplings through the center pins and the cab frame. The longitudinal sills of the frame consist of 12-inch channels. The frame is braced transversely above the center pins, by flanged plates which are riveted to the longitudinal channels. An air duct, for the ventilation of the motors, is built into the frame between the center sills.

The locomotive is designed for double-end operation and has a central cab, with sloping hood at each end. The cab is of steel, with a wood floor. The doors and windows are so placed as to afford an unobstructed view when running in either direction.

The motors are of a new type, styled No. 562-A-6, which has been especially developed by the Westinghouse Electric & Mfg. Company for high-potential direct-current. Two motors are permanently connected in series so that the voltage across each is 750 volts. Their nominal rating is 75 kw. (100 H. P.).

These motors have a unique system of ventilation. While air for cooling is normally provided by a motor-driven blower, each motor has a fan at one end of the armature which will provide sufficient ventilation to operate the locomotive at three-quarter capacity in case of accident to the blower.

The control equipment used on this

locomotive is H. electro-pneumatic and is practically the same as the high-voltage control outfits used on the motor cars on this system.

The principal dimensions of this locomotive are as follows:

Wheel-base, rigid, 6 ft. 6 in.

Wheel-base, total, 22 ft. 6 in.

Distance between truck centers, 16 ft.

Diameter of wheels, 36 in.

Size of journals, 5 in. x 9 in.

Width, 10 ft.

Height to top cab, 12 ft.

Length between coupler knuckles, 34 ft 9½ in.

Weight, 100,000 lbs.

#### Generating Units.

President E. M. Herr of the Westinghouse Electric & Mfg. Company, in a recent address before the Railway Club of Pittsburgh said, "Due largely to the wonderful development in the steam turbine and its direct-connected electric generator, and the remarkably flexible, efficient and easy distribution of electricity, we are on the eve of a notable—in fact, I believe an epoch-making—change in the utilization of electric power.

"First—The modern steam turbo-generator makes it possible to concentrate enormous amounts of power generation in one place.

"Second—This makes possible and advantageous very large individual generating units. The growth in the capacity of generators has really been enormous, made possible by the steam turbine.

"Third—Electricity can be transmitted long distances in large or small quantities and its characteristics changed at will, all with small losses and at comparatively low cost."

The speaker then proceeded to trace the development of large generating units as exemplified by certain notable installations of central stations, industrial and railway plants, and then discussed the effect of the concentration of such a large amount of power in one station.

Mr. Herr said the building of units as large as 50,000 and 60,000 kw. was contemplated.

This address has been published in pamphlet form by the Westinghouse Electric Company, and will be sent to anyone interested.

#### Recent Improvements in Single-Phase Rotary Converters.

Mr. Val. A. Flynn, writing in the *Electrical World*, states that single-phase converters have not been much used in the past, mainly because it was found well-nigh impossible, or at least very difficult, to start them from the alternating-current side, and also because of serious commutating difficulties and low weight efficiency. The use of a short-circuited damping winding in connection with field structures, as heretofore employed, certainly

improved the commutation and the efficiency to a great extent, but failed to solve satisfactorily the commutation problem and greatly increased the already great starting difficulties.

In 1905 the author made an effort to overcome these difficulties, and he finally evolved the machine about to be described. This new rotary converter can be started from the alternating-current side with a large torque per ampere, commutates perfectly in normal operation, and has a good efficiency and high power factor. Its main distinctive feature is the arrangement of the damping winding. In one connection this can be used for starting the machine from the alternating-current side, in another for improving the commutation and efficiency in normal operation. To this end the short-circuited damping winding is arranged just like a polyphase winding, the several phases are placed in a certain space relation to the brush line, and provision is made for interrupting the short-circuit of at least one of the phases at starting. The field structure, or stationary part, of these converters is made without defined polar projections.

While this machine was designed mainly for the purpose of converting single-phase into unidirectional current, it can be used for the converse process, and is sometimes used as a synchronous single-phase motor.

When employed for converting alternating into direct current, it enables single-phase currents to be utilized for charging storage batteries or for operating direct-current arc lamps, for instance, in moving picture shows or for any kind of electrolytic work.

Operated as a single-phase synchronous motor, it is particularly useful in connection with revolving rectifying apparatus.

These machines have often been put to a double use in automobile garages sheltering electrically operated vehicles, being employed to charge the storage batteries of the vehicles at night and to drive various auxiliary appliances, like machine tools, pumps, vacuum cleaners and buffing wheels, during the day.

The Wagner Electric Manufacturing Company, of St. Louis, has acquired the control of the various United States patents covering this converter and has for some time past been regularly manufacturing these machines in different sizes.

In several departments of train operating the Erie Railroad people have found that cheapness in first cost does not always mean economy. It seems that objection was raised that they were paying too much for gasoline. It was decided to try a cheaper grade of gasoline and the change was made. After a thorough trial extending over several thousand miles of operation, it was found that the cheaper gasoline cost more per unit of distance than the more costly gasoline.

# Items of Personal Interest

Mr. H. J. Whyte has been appointed supervisor of car work of the Eastern Lines of the Canadian Northern.

Mr. John D. Rogers has been appointed roundhouse foreman of the Oregon Short Line with office at Pocatello, Ida.

Mr. George Mott has been appointed district master mechanic and trainmaster of the Alberta division of the Canadian Pacific.

Mr. R. E. Anderson has been appointed air brake instructor on the Chesapeake and Ohio, with headquarters at Richmond, Va.

Mr. W. E. Grove has been appointed assistant general car inspector of the Philadelphia & Reading, with office at Reading, Pa.

Mr. C. E. McGann has been appointed roundhouse foreman of the Cincinnati, Hamilton & Dayton with office at Ivorydale, Ohio.

Mr. C. J. Quantic has been appointed master mechanic of the Pacific division of the Canadian Northern, with office at Port Mann, B. C.

Mr. Joseph Bluetge has been appointed road foreman of engines on the Erie, with office at Cleveland, Ohio, succeeding Mr. J. J. McNeill.

Mr. B. E. Nevins has been appointed road foreman of engines of the first and second divisions of the Virginia railway, with office at Victoria, Va.

Mr. G. F. Shull, formerly acting master mechanic of the Carolina, Clinchfield & Ohio at Erwin, Tenn., has been appointed master mechanic at Erwin.

Mr. B. Corbett has been appointed master mechanic of the Missouri, Kansas & Texas, with office at Smithsville, Tex., succeeding Mr. J. R. Greiner, resigned.

Mr. F. J. Yonkers has been appointed road foreman of equipment on the Colorado division of the Chicago, Rock Island & Pacific, with office at Goodland, Kans.

Mr. E. E. Keyser has been appointed assistant road foreman of engines of the third and fourth divisions of the Virginia railway, with office at Princeton, W. Va.

Mr. M. E. Hamilton, formerly in the employ of the Garlock Packing Company, has been appointed general air brake inspector of the St. Louis & San Francisco.

Mr. J. W. Tenney has been appointed road foreman of equipment with jurisdiction west of the Missouri division, west of Eldon, Iowa, with office at Trenton, Mo.

Mr. R. W. Burnet, formerly general master car builder of the Canadian Pacific, has been elected vice-president of the National Car Equipment Company of Chicago, Ill.

Mr. H. A. English has been appointed

master mechanic of the Central division of the Canadian Northern with office at Winnipeg, Man., succeeding Mr. G. H. Hedge, promoted.

Mr. E. Ronaldson, formerly locomotive foreman of the Canadian Pacific at Lambton, Ont., has been appointed district master mechanic on the same road with office at Farnham, Que.

Mr. C. A. Dunaent has been appointed general foreman of the Rock Island at Haileyville, Okla., and Mr. Samuel Tolley has been appointed roundhouse foreman at the same place.

Mr. H. N. Cathcart, for several years traveling fireman on the Philadelphia & Reading, has been promoted to fuel and locomotive inspector on the same road, with office at Reading, Pa.

Mr. J. J. McNeill, formerly road foreman of engines on the Erie at Cleveland, Ohio, has been appointed supervisor of locomotive operation on the same road, with office at Youngstown, Ohio.

Mr. G. H. Hedge, formerly master mechanic of the Central division of the Great Northern, has been appointed general master mechanic of the Western Lines, with office at Winnipeg, Man.

Mr. R. M. Kincaid, formerly valuation engineer of maintenance of equipment of the Chicago & Eastern Illinois, has been appointed master mechanic at Villa Grove, Ill., succeeding Mr. F. Studer, resigned.

Mr. J. H. Anderson has been appointed tool foreman of the Santa Fe at Clovis, N. M., succeeding Mr. John Gibson who has been transferred to a similar position on the same road at Topeka, Kans.

Mr. C. W. Hickson, formerly signal supervisor of the Vandalia at Terre Haute, Ind., has been appointed signal supervisor of the Pennsylvania Lines West, succeeding Mr. A. J. Scifert, deceased.

Mr. L. C. Ord, assistant works manager of the Angus car shops of the Canadian Pacific at Montreal, Que., has been granted leave of absence to enter active service as lieutenant of artillery in the Canadian expeditionary force.

Mr. W. J. Kinsell, formerly chief clerk to Mr. David Van Alstyne, assistant to the vice-president of the New York, New Haven & Hartford has been appointed assistant shop superintendent of the same road at Reading, Pa.

Mr. Edward Sheffield, formerly assistant signal supervisor of the Texas & New Orleans has been appointed acting signal supervisor of signals of the Houston & Texas Central, during the leave of absence of Mr. L. H. Feldlake.

Mr. C. N. Beckner, formerly assistant signal engineer of the Louisville & Nashville at Louisville, Ky., has entered the

service of the Federal Signal Company as superintendent of construction with headquarters at Chicago, Ill.

Mr. L. W. Baldwin has been appointed general manager of the Georgia Central, with headquarters at Savannah, Ga. Mr. Baldwin was formerly superintendent of the Illinois Central on all lines south of the Ohio river.

Mr. Paul M. Lincoln, formerly employed on the engineering department of the Westinghouse Electric & Manufacturing Company, has resigned his position to devote his time in the manufacture of a meter that he has invented.

Mr. George Lawler has been appointed division foreman of the Santa Fe, with office at Belan, N. M., succeeding Mr. J. A. Baker, and Mr. A. Fugate has been appointed roundhouse foreman on the same road with office at Albuquerque, N. M.

Mr. E. H. May formerly assistant on the engineering department of the Indianapolis division of the Pennsylvania Lines West, has been appointed assistant division engineer of the Michigan division of the Vandalia, with offices at Logansport, Ind.

Mr. T. L. Reed, formerly assistant master mechanic of the Seaboard Air Line at Hamlet, N. C., has been appointed master mechanic of the North Carolina division of the same road with office at Hamlet, and the office of assistant master mechanic has been abolished.

The Westinghouse Electric & Manufacturing Company announces the following changes: Mr. S. A. Chare, Mr. T. J. Pace and Mr. Carl G. Schluederberg have been appointed assistants to Manager J. J. Gibson; Mr. C. E. Stepiens has been appointed manager of the illuminating department; Mr. C. Streamer becomes manager of the switchboard department, and Mr. A. P. Joseph becomes the head of the order section; Mr. M. C. Morrow becomes manager of the appliance section, and Mr. M. C. Rypinski manager of the meter section.

Mr. N. S. Reeder has been elected vice-president of the Pressed Steel Car Company, with headquarters at New York City; Mr. J. B. Rider has been elected vice-president, with headquarters at Pittsburgh, and will continue to perform the duties of General Manager in charge of operations; Mr. J. F. MacEnulty, formerly general sales manager, has been elected second vice-president, with headquarters at New York City; Mr. H. P. Hoffstot has been appointed assistant sales manager, Central District, with headquarters at Pittsburgh.

Mr. P. Conniff, formerly superintendent of shops of the Baltimore and Ohio



railroad at Mount Clare, Baltimore, has been appointed special inspector, being succeeded by Mr. L. Finnegan, transferred to Baltimore from similar position at Glenwood Shops, Pittsburgh. Mr. E. J. Brennan, formerly master mechanic of the Buffalo, Rochester and Pittsburgh railroad, has been appointed in Mr. Finnegan's place at Glenwood. Mr. Finnegan has been in Baltimore and Ohio service about four years as master mechanic and superintendent of shops at Glenwood.

#### C. E. Postlethwaite.

Nearly all railroad officials have been for years pleasantly acquainted with Mr. C. E. Postlethwaite, representing the



CHARLES E. POSTLETHWAITE.

Pressed Steel Car Company of Pittsburgh. In the past Mr. Postlethwaite has been local manager for his company, and now his numerous friends are congratulating him upon his appointment to be general manager of the Pressed Steel Car Company and of the Western Steel Car & Foundry Company, with headquarters in New York. We join heartily in the congratulations extended to Mr. Postlethwaite, whose genial personality is always welcome in this office.

#### OBITUARY.

##### William Crowe Hayes.

A host of men belonging to the mechanical department of our railroads will learn with sorrow that their friend, William Crowe Hayes, superintendent of locomotive operation of the Erie Railroad, died at his home in New York on Christmas day. Mr. Hayes was born in 1853, received a common school education, and in early manhood began railroad life as fireman on what is now a part of the Pere Marquette Railroad. From there he went to the Lake Shore & Michigan Southern, where he remained as fireman and engi-

neer for two or three years, after which he went to the Minneapolis & St. Louis as engineer and remained there for twenty years. When Mr. F. D. Underwood became president of the Baltimore & Ohio Railroad he took Mr. Hayes along as locomotive superintendent, a position he held till Mr. Underwood became president of the Erie Railroad, when Mr. Hayes accepted the position of general road foreman of engines. On the Erie Mr. Hayes was successively assistant mechanical superintendent, superintendent employment bureau, superintendent Delaware and Jefferson divisions, and latterly superintendent of locomotive operation.

Mr. Hayes had a strong alluring personality which made him highly popular with all the people he came in contact with, that characteristic commending him for leadership in various associations. He was a prominent member of the Brotherhood of Locomotive Engineers and of the Traveling Engineers' Association, of which he was president 1911-12. He was a member of several other associations, among them the Railway Master Mechanics' and International Fuel Association. He was also a Royal Arch Mason.

In 1877 Mr. Hayes married Miss Maria Whitmeier, by whom he had one daughter, both of whom survive him.

##### Thomas James Hennessey.

The death is announced on December 4 of Mr. T. J. Hennessey, for many years master mechanic on the Michigan Central railroad. He was born in London, Ont., January 1, 1845, and commenced his railroad career as fireman in 1872. He was promoted to engineer in 1874, travelling engineer 1889, master mechanic at Detroit 1893, master mechanic at Jackson 1895, master mechanic at Bay City, Mich, 1903, and retired from service on account of age limit, February 1, 1915, thus completing 43 years' service with the company, 22 years of which was occupied as master mechanic at the points named. Mr. Hennessey was very highly esteemed among all who had the honor of his acquaintance.

##### John Sinclair Booth.

Much regret is expressed, especially among railroad men in the South, at the announcement of the death of Mr. John S. Booth, who died last month at his home in Atlanta, Ga. He was born in Gloucester county, Virginia, in 1858, and served an apprenticeship as a machinist. He won rapid promotion on the Southern Railway, and was foreman at Salisbury and at Spencer, N. C. In 1900 he was appointed master mechanic on the North Carolina & North-Western Railway, and served in that capacity until incapacitated by failing health in 1912. He was an active member of the Railway Master Mechanics' Association and other railroad

clubs and societies, and was very highly esteemed. With few educational advantages in his youth, except at night schools Mr. Booth remained an earnest student all his lifetime, and he won his place in the front rank of railway men by his high intelligence and noble character.

##### James Sinclair.

In November last there died in Inverness, Scotland, James Sinclair, a Scottish Highlander, 52 years old, who had passed many years of his life as master builder on a railway in Venezuela. He supervised several important improvements on railway structures and was regarded as a man of unusual construction ability. He was a first cousin of our Angus Sinclair

##### Frank H. Bailie.

Mr. Frank Howard Bailie, for twenty-seven years associated with the H. K. Porter Company, Pittsburgh, Pa., and latterly assistant manager of sales for the company, died after a brief illness from pneumonia on December 14. He was well-known among railroad men and very highly esteemed.

##### Another Apprentice School Started on the Erie Railroad.

Owing to the encouragement given by Mr. F. D. Underwood, president of the Erie Railroad Company, that company has been conspicuous of late years in promoting means for educating on scientific lines the apprentices belonging to the various repair shops. For years the company has maintained apprentice schools connected with the shops at Meadville, Pa., Hornell, N. Y., Susquehanna and Denmore, Pa. and Port Jervis, N. Y. Now the company has organized an apprentice school at Jersey City, N. J.

The opening session of that school was held on December 8 in a hall connected with the repair shops at Jersey, where an attendance of 78 apprentices or young mechanics listened to an address given by Dr. Angus Sinclair who is Special Instructor for the company. He said:

"Men like myself who had to acquire some knowledge of the science of mechanical engineering, are inclined to be envious of the educational privileges you are enjoying through the instruction given in these schools. The teachers can impart information, but it lies with you to make it a power capable of lifting you from a low to a high position in life. I have seen several attempts to educate mechanics which failed because those to be benefited grew weary of well doing, and refused to cooperate with the instruction intended for them. To you young men, I should say be persevering and industrious in receiving the instruction arranged for your benefit. To profit thoroughly from the educational opportunities now placed within your reach, industry, per-

severance and habit of keen observation are essential. Cultivate these and your future will be successful.

"The educational and practical training which you are receiving will fit you to fill satisfactorily the highest positions in the railway mechanical world. This scientific education combined with the excellent shop work you are learning to perform, makes you better prepared to achieve renown in your choice calling than the training given to any other class of men. In my opinion you will be better trained for becoming leaders in the railway world than any other class of men who have had railway experience.

Very few of the men who have taken a lead in managing and in promoting railway enterprises, had received any share of what is known as higher education and few of them enjoyed such practical training as you are going to enjoy. Modern conditions make scientific knowledge a power in railway management and operation, but that has not always been the case. The invention of the locomotive engine made modern conditions of railway operating possible, but the locomotive was invented and developed by intelligent workmen with little book learning. The man who first equipped a piston to move inside of a cylinder, though producing a practical steam engine, was a working blacksmith. Not a common blacksmith, although he performed blacksmithing, but a man possessed of inventive faculties and keen habits of observation which he cultivated to good purpose. Oliver Evans who invented the high pressure steam engine and made the locomotive a possibility was a grain miller. Peter Cooper who built the first American locomotive was a merchant. The list of names associated with the improvement and development of railway machinery makes a long story, but most of the men who performed important services to the world in this line had been workmen. The opportunities that came to these persons are within your reach and you are enjoying the training that will make you ready for the opportunity. We frequently heard it said that a mechanic's opportunities for distinguishing himself are not so good as they once were. That is a mistake; the opportunities of advancement were never better than they are today.

Railroad life to day presents better opportunities of advancement by men having no other means of promotion beyond their own industry and native ability than any other line of human industry. Napoleon as a note of encouragement to the rank and file of his armies, assured them that every French soldier carried the possibility of a field marshal's commission in his knapsack; circumstances justifies the assertion that every ambitious man of good character entering railway service enjoys the possibility of becoming a president of some transportation company.

### Ignorant Workmen.

The methods of instruction now followed by leading railway companies for the benefit of apprentices and others is spreading useful information that must prove of great benefit to the recipients. That is a commendable and desirable change, for it used to be the case that apprentices and others picked up principles of their business or remained ignorant. Many men engaged in repairing railroad machinery are woefully ignorant of the principles underlying locomotive construction.

An instructor of apprentices belonging to one of our leading railroads offered to instruct a class of machinists and others upon the details of locomotive construction. The first question he asked was: "What is lead?" No one answered at first, but finally one of the men said: "Lead is a piece of lead placed upon the top of a valve to hold it down."

The next question asked: "What is lap?" The answer given was: "A band put round the boiler to keep it from bursting."

These were exceptionally stupid answers, but most of these workmen were ignorant beyond belief concerning details of the work they were daily employed upon.

### Widows and Orphans as Railway Dependents.

At a railway club meeting General Miller, of the Galena Oil Company, made some reference to widows and orphans being benefited by the economical operation of railways, and some of his audience laughed, thinking that the General was joking. In closing his remarks at the end of the discussion, General Miller remarked: "My friends here, I guess, thought I was speaking sarcastically when I spoke of the widows and orphans. I know there have been slurs placed on the words 'widows and orphans' as owners of stock in railroad companies. Gentlemen, I happen to know many of them whose *all* is in railroad securities, and it behooves us to have a kindly feeling towards them, and to avoid the all too common flippant way of speaking of them—the widows and orphans of some of the dearest friends we ever had on earth."

### A Chinaman Who Knew His Rights.

Recent experiences of the writer in transatlantic travel bring back reminiscences of the days and nights when sleeping cars had not come into use. Passing two or three nights in a railroad car without any visible means of repose was trying and frequently led to ingenious attempts at securing comfort. A long ago incident of travel was:

There were two seats in the car turned

to face each other. One was occupied by a lady, the other by a Chinaman. Evidently the lady did not relish the presence of the Chinaman, so she explained to him that she wanted to take the cushions and place them lengthwise to make a comfortable lounge.

John said all right and got out into the aisle while the lady toiled to form the cushions into a bed. When they were arranged to her satisfaction, the lady lay down upon the improvised bed, with the idea that she could take her comfort on both cushions. She expected that the Chinaman would raise no objections to a white lady taking the space provided for four persons; but she reckoned without thinking on a Chinaman's wiles. As soon as she had got comfortably settled the Chinaman crept in beside her, and stretched himself by her side. The lady, as soon as she realized that she had a bed-fellow, started up in a rage looking fiercely at the Chinaman, but he did not budge, so she climbed over him and walked away into the next car, amidst the laughter of the people she deserted.

### Fishing for What?

A tourist was just walking out of the hotel when he saw an aged villager sitting on the garden wall, solemnly holding a line and rod over the flower bed as if he was fishing.

Asking the manager of the place what was the matter with the poor man, he was told that he was "just a bit soft."

After watching the motionless figure for some time, the tourist went up to him and asked:

"What are you doing?"

"Fishing," was the solemn reply.

The stranger then asked the fisherman to come and have a drink. Over the two glasses he sought to solve the mystery.

"So you were fishing," he said presently. "Have you caught many this morning?"

"Yes," replied the old man, placidly. "you're the sixth."

### One for the Minister.

A good story was told recently at a church meeting in Dundee. There was a vacancy in a country church, and the managers, in the old-fashioned way, drew up a short list of candidates, and the chosen ones to preach before the congregation. One youthful aspirant preached what he considered an excellent sermon, and after the service endeavored to "draw" a venerable elder. "Do you think I have any chance, Mr. Blank?" he asked. "No, I dimna," was the uncompromising reply. "Surely you don't mean that?" said the abashed youth. "I think you might get a far worse man than me for your pulpit." The gruff old fellow looked him up and down and replied; "Whaur?"



## Discovered Over Fifty Years Ago

That the use of flake graphite combined with silica made the most ideal pigment for protective paint that has ever been produced. And its use for over fifty years has proven that

# DIXON'S SILICA GRAPHITE PAINT

has no equal as a protective paint for steel, iron and wood. It retains its original toughness and elasticity for almost indefinite periods. Dixon's Silica-Graphite Paint has been used on many structures all over the world. "There's a reason." Write for booklet No. 69-B, to the

**Joseph Dixon Crucible Company**  
Jersey City, New Jersey



Established  
1827



B-19

### RAILROAD NOTES.

The Elgin Joliet & Eastern, has plans for a car repair and machine shop at Joliet, Ill.

The Pennsylvania is rebuilding its roundhouse at Derry, Pa., at a cost of \$35,000.

The Southern Railway has ordered 10,000 tons of rails from the Maryland Steel Company.

The Santa Fe has let contracts for extensive shop improvements at Albuquerque, N. M.

The French Government has ordered 85,000 tons of rails from the Pennsylvania Steel Company.

The Beaver Penrose & Northern, it is said, will build a roundhouse and shops at Penrose, Colo.

The Erie Railroad has ordered 10 Pacific locomotives from the American Locomotive Company.

The Norfolk Southern has ordered 4 Consolidation locomotives from the Baldwin Locomotive Works.

The Union Railroad has ordered 5 Consolidation locomotives from the Baldwin Locomotive Works.

The Bethlehem Chile Iron Mines Company has issued inquiries for 25 100,000-lb. capacity steel ore cars.

The Cuba Railroad is reported as ordering 20 locomotives from the American Locomotive Company.

The Chicago Great Western has ordered 5 Mikado type locomotives from the Baldwin Locomotive Works.

The Western Maryland proposes during the coming year to install automatic block signals on 106 miles of its line.

The French Government has given the Maryland Steel Company an order for 90,000 tons of rails and fittings.

The Oklahoma, New Mexico & Pacific is erecting shops and roundhouse at Ardmore, Okla. The shop building will be 70 by 80 ft.

The National Railways of Mexico plans to build large shops at Piedras Negras, Coahuila, Mexico, for the manufacture of freight and passenger cars and other equipment.

The H. K. Porter Company, it is said, has received orders for 25 more locomotives from Russia and has just completed a shipment of 50.

The Fort Smith & Western is reported to have plans for the equipment of car and machine shops as well as terminals at Oklahoma City, Okla.

The Great Northern has ordered 175,000 tie plates, 7,000 kegs of track spikes, 8,000 kegs of bolts and 90,000 angle bars from the Lackawanna Steel Company.

The Toledo, St. Louis & Western has divided an order for 10,000 tons of 85-lb. rails between the Illinois Steel Company and the Carnegie Steel Company.

The Pennsylvania Lines West of Pittsburgh have ordered 1,000 gondola cars from the American Car & Foundry Company and 1,150 70-ton hopper cars from the Haskell & Barker Car Company.

The Great Northern has divided an order for 8,000 tons of rails among the Illinois Steel Company, the Cambria Steel Company, the Lackawanna Steel Company and the Colorado Fuel & Iron Company.

The Chesapeake & Ohio has let contract to the Combs Lumber Company of Lexington, Ky., to erect a \$25,000 building in Netherlands yards, Lexington, Ky., for repair shop, storehouse, club house and office.

The San Pedro Los Angeles & Salt Lake has awarded contract to the Union Switch & Signal Company for automatic block signals to be installed on 56 miles of track between Los Angeles and Riverside, Cal.

The Pennsylvania has let another contract for a large number of locomotives, 63 in all, of which 15 are to be constructed at Lima Locomotive Works and 48 by American Locomotive Company. This company has been making inquiries for 9,000 freight cars and 240 passenger cars.

A committee of steel manufacturers and others under the lead of Elbert H. Gary, chairman of the Steel Corporation, and Charles M. Schwab, president of the Bethlehem Steel Corporation, are contributing toward the presentation of an armored train to the National Guard of New York. The train will have a battle car heavily protected with armor plate and six or seven lightly armored cars equipped with machine guns and capable of high speed. The steel makers have promised to contribute and to furnish the armor plate and other metal parts of the train at cost.

### Locomotive Boiler Horsepower.

Experiments conducted under supervision of Mr. D. F. Crawford, general superintendent of motive power of the Pennsylvania Railroad, indicated that to obtain from locomotives the average power required from them it is necessary to consume fuel at the rate of 100 pounds of coal per square foot of grate per hour, and to obtain the maximum power required, it is necessary to consume 150 pounds, and at times an excess of that amount per square foot of grate per hour. To obtain the power necessary to perform the work demanded, a boiler which from its heating surface would be rated at 320 horsepower is frequently forced to develop over 1,500 boiler horsepower. Other boilers rated at 400 horsepower have developed as high as 1,994 boiler horsepower.

### Use and Waste of Heat.

People who handle the steam engine and are familiar with heat phenomena are but rarely acquainted with the amount of heat required to perform the work of train hauling or machine operating. It is edifying to enquire into the amount of heat expended in performing operations that all engineers are accustomed watching.

The wastage of heat energy under present methods is appalling. About 65 per cent. of the heat energy of coal can be put into the steam boiler, and from this less than 15 per cent. of mechanical power is obtained. Few locomotives utilize 10 per cent. of the fuel energy. Putting mechanical power into electricity, only from 2 to 5 per cent. is turned into light; or in other words, from coal to light we get on an average only about one-half of one per cent. of the original energy, wastage of ninety-nine and a half per cent. of every pound of coal used. The very best possible with largest and best machinery is a little more than one pound for every hundred pounds consumed. Who says that the opportunities of the inventor have been exhausted?

### Convinced at Last.

When the American Railway Master Mechanics' Association was devoting much attention to increasing the size of the locomotive, which had been an eight-wheel engine weighing 60,000 lbs. or on four drivers, an annual report expressed the belief that the proper weight on each driving wheel was 16,000 pounds. Builders have varied from that considerably, but when the weight per driver exceeded 16,000 pounds, the engine seldom gave satisfaction.

An impression prevailed in railroad circles for many years that a 4-inch tire did not wear so well as a 3-inch tire, but exhaustive tests of Midvale tires made at the Watertown Arsenal proved that there was no difference in the wear of these

tires when the material was the same. It took years to convince master mechanics that the wear could be the same, but all doubts about the wear of the thicker tires have now passed away, and the thicker tires have a constantly growing preference.

### Put Off the Wrong Passenger.

The Glasgow *Herald*, which is unusually well posted on railway matters, relates the following incident as a note of railway experience:

An old gentleman joining the Scotch Express at Enston, London, one night informed the conductor he was traveling to Crewe, and wished to sleep all the way up. He stated that whenever he was awakened out of a sleep he refused to obey anyone, and always gave way to very strong language. "However," he said, "no matter what I say or do, put me out at Crewe." This the conductor consented to do, and the old man fell into a peaceful slumber. After a good snooze he awoke and discovered the train was at a standstill—at Glasgow. The Scotch conductor was standing at the door of his van, and the passenger approached him with flaming face. He made several forcible remarks, and asked him why he did not put him out at Crewe. The conductor listened in silence, and looked at the old man for a while. Then, gripping his beard with his right hand, he said: "Mon, you've a powerful vocabulary, richt enough, but you cudna haud a caundle to the man we put oot at Crewe."

### Would Tire Them.

A conscientious owner of a queer tempered cow sent her to market, carefully instructing his herder to warn all intending purchasers that the animal was most troublesome to milk. The man returned, having sold her very advantageously, and was anxiously questioned as to whether he had given the enjoined warning. "Troth, and I did so, your Honor. Sure, when they axed me was she a good milker, I up and tould them it's tired milkin' her they'd be. And bedad that same was no lie."

### Change Here.

A native of the Emerald Isle was traveling by railway for the first time in his life. The train stopped at a station, and the guard, opening the door of the carriage in which Pat was seated, called out: "All change here!"

"All change here!" exclaimed Pat, aghast. "Shure then, Mister, Oi've only wan shilling and two dirty coppers in the woide, woide wurruuld, an' yu wudn't be so mane as ter be afther takin' thim from me, wud ye, sorr?"

# GOLD Car Heating & Lighting Company

Manufacturers of

ELECTRIC,  
STEAM AND  
HOT WATER  
HEATING  
APPARATUS  
FOR RAILWAY CARS  
VENTILATORS  
FOR PASSENGER  
AND REFRIGER-  
ATOR CARS  
ACETYLENE SYSTEM  
OF CAR LIGHTING

Send for circular of our combination PRESSURE AND VAPOR SYSTEM OF CAR HEATING, which system automatically maintains about the same temperature in the car regardless of the outside weather conditions.

Main Office, Whitehall Building  
17 BATTERY PLACE  
NEW YORK

# Hydraulic

**Riveters Fixed and Portable  
Punches, Shears,  
Presses, Lifts, Cranes  
and Accumulators.**

**Matthews' Fire Hydrants,  
Eddy Valves  
Valve Indicator Posts.**

**The Camden High-Pressure Valves.**

## Cast Iron Pipe

**R. D. Wood & Company  
Engineers, Iron  
Founders, Machinists.**

**100 Chestnut St., Philadelphia, Pa.**

## Nichols Transfer Tables Turntable Tractors

**GEO. P. NICHOLS & BRO.  
1090 Old Colony Bldg. CHICAGO**

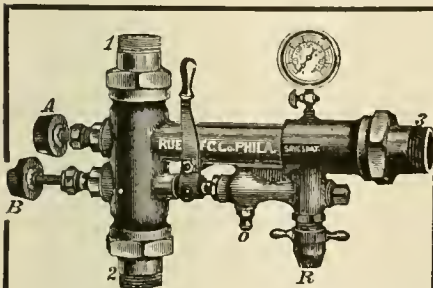

### NOW IS THE TIME to install a Rue Boiler Washer and Tester,

For you will need it when cold weather comes. It will wash out, test and fill your boiler, all with hot water, and have it ready for use in one hour.

THINK IT OVER.  
Catalog on Boiler Washers A-5.  
Catalog on Injectors B-5.

**Rue Manufacturing Co.,  
228 CHERRY STREET  
Philadelphia Pa.**

Manufacturers of Injectors, Ejectors,  
Boiler Washers and Testers, Boiler Checks,  
Check Valves.

# Books, Bulletins, Catalogues, Etc.

## Maintenance of Way and Structures.

The McGraw-Hill Book Company, New York, taking advantage of the revival in railroad traffic in America, are publishing a variety of books on various subjects appertaining to railroad matters that are models of their kind. Among these a work on Maintenance of Way and Structures, by William C. Willard, Assistant Professor of Railway Engineering, McGill University, holds a high place. It extends to 451 pages, is divided into 21 chapters, and contains 232 illustrations and 24 tables. The book sets forth in a clear style the best accepted practice of the present day in the important branch of maintenance of way and structures. The book may well become a standard for the maintenance of way engineer or the student studying a course of engineering. Individual railways are given as illustrations of the means and methods described. No other work furnishes such a number of drawings and photographs, and the carefully prepared index may well form an example to other authors. The subject is completely covered, with the exception of the subject of signalling, which, of course, calls for a volume by itself. The book has all the usual excellent qualities in letterpress and binding of the enterprising publishers. The price of the book is four dollars.

## Laboratory Tests of a Consolidation Locomotive.

The University of Illinois has just published Bulletin No. 82, being results of locomotive tests in the Experiment Station. The tests were conducted by Professors Schmidt, Snodgrass and Keller, of the Railway Engineering Department of the University, and constitute the first work of the recently established locomotive testing laboratory. The tests were made on a typical consolidation locomotive loaned to the University of Illinois by the Illinois Central railroad, and the data secured and the results derived therefrom are presented and analyzed in detail. Since this is the first series of tests conducted in the new laboratory, the bulletin includes a description of the laboratory equipment and the methods of testing employed.

The locomotive was first tested in the condition in which it was received from service. It was then subjected to certain repairs, and again fully tested. The main purpose of the tests was to determine the general performance of the locomotive and the performance of its boiler and engines after the repairs were made and when the locomotive was in excellent condition. The secondary purpose was to study the effect of some of these repairs upon the locomotive's perform-

ance. The locomotive was worked during the tests throughout a range of speed corresponding to that which would ordinarily prevail in service. At each of the various speeds the endeavor was made to vary the cut-off throughout as wide a range as the capacity of the boiler or of the grates would permit. All tests were made with the throttle wide open.

The maximum amount of dry coal fired per hour was 11,127 pounds or 224.5 pounds per square foot of grate per hour. The maximum equivalent evaporation per hour was 57,954 pounds or 17.65 pounds per square foot of heating surface per hour. The University of Illinois equipment makes possible the collection of all stack cinders and the information relative to cinder losses which is presented shows these losses to have ranged from 3 to 16 per cent of the weight of the dry coal fired for what might be considered ordinary service conditions and to have amounted to 27.4 per cent of the weight of the dry coal fired during one test under extreme conditions of firing and draft.

Copies of the bulletin may be had on application to W. F. M. Goss, director of the Engineering Experiment Station, University of Illinois, Urbana, Ill.

## Principles of Locomotive Operation and Train Control.

The new and exacting problems brought forward by the adoption of steel cars and heavier trains on railroads has engaged the attention of many of the most learned mechanical engineers of our time. Among these, A. J. Wood, associate professor, in charge of railroad mechanical engineering, in Pennsylvania State College, has made a notable contribution to railroad literature in a book of 271 pages published by the McGraw-Hill Book Company, New York. The author has enjoyed exceptional advantages in the use of State and other testing plants, and the results of his careful experiments and close study of the involved subjects are seen on every page. While the book has been written primarily for use in technical schools, the engineer may, by the use of this book, review the theory on which are based many problems in design and construction. The principles are clearly set forth and beyond this, of course, lies the field of extended study. The book is divided into sixteen chapters, and is profusely illustrated with drawings, folders and reproductions of photographs, and in every detail the accomplished author shows a thorough mastery of the subject. The letterpress is elegant, the binding substantial, and the price is three dollars.



## ASHTON POP VALVES AND GAGES

The Quality Goods That Last

The Ashton Valve Co.  
271 Franklin Street, Boston, Mass.  
No. 174 Market St., Chicago, Ill.

### American Anvils.

The Hay-Budden Manufacturing Company, 254-278 North Henry street, Brooklyn, N. Y., have issued a neat pamphlet containing the revised lists and patterns of the celebrated "Hay-Budden" solid wrought anvils. The popularity of these anvils is the best proof of their superiority. They are universally admitted to be just right, and while marked improvements have been made in recent years in the material and patterns, the consensus of opinion now is that they cannot be further improved upon. The perfection of the details of the hydraulic presses, furnaces, cranes and other appliances is such that while the quality and patterns of the anvils have been improved, the prices have been lowered. Send for a copy of the company's new catalogue and observe the price lists, and if any confirmation of the growing demand is desired ask the nearest dealer.

### Low-Grade Fuel in Europe.

Technical Paper 123, issued from the Washington Government Printing Office, contains valuable information in regard to the use of low-grade fuels in Europe, with occasional reference to experiments in America, from which it would appear that the colliery refuse heaps which have been accumulating for years are found to contain a good percentage of coal. This material is being handled by crushing and washing machines, and the worked coal is being used; 115 tons of the unworked material yielding as much as 60 tons of numbers 1, 2 and 3 nuts, and 40 tons of slack. The material was reported as containing about 25 per cent ash when used in the producers. The experiments have been conducted by Mr. R. H. Fernald, and copies of the paper may be had through the Superintendent of Documents, Washington, D. C.

### Graphite.

The current issue of *Dixon's Graphite* contains an interesting descriptive article on a new graphite lubricator for locomotive cylinders. The appliance has no connecting rods or moving parts, but consists of a cup containing graphite and arranged for attachment to any convenient part of the locomotive and is connected by a shut tube to the indicator plug on the steam cylinder. The varying steam pressure in the cylinder when the engine is running operates a small differential piston contained in the cup. By adjusting the length of travel of this piston, the amount of graphite fed to the cylinder can be increased or decreased at will. The exhaust steam carries the graphite into the valve chambers, thereby giving them the same advantage of lubrication as well as the cylinders. One ounce of graphite per 100 miles is sufficient. It is claimed that as much as 7 1-2 per cent of decrease in fuel

consumption has been made by the use of the appliance.

### Staybolts.

The Flannery Bolt Company maintain the interest of their monthly *Digest*, and a mass of interesting data is presented in regard to the safeguarding of boilers from the effects of severe stresses, owing to the irregularities of sheet expansion. Continual staybolt breakage was in past years the source of greatest trouble, but this menace has by gradual process of development been largely overcome, and the use of the Tate flexible staybolt has fully proved to be a most useful and practical connecting member to the fire-box assemblage, and a standard for reliable and economic service. The December issue of the company's publication contains a mass of matter in little bulk, and a copy should be in the hands of all who are interested in steam boiler service. Send for a copy to the company's office, Pittsburgh, Pa.

### The Terry Turbine.

"The Terry Turbine" is the title of a new Bulletin just issued by the Terry Turbine Company, giving a general description of the various turbine applications, and dealing particularly with different kinds of high, low and mixed pressure turbines. Nearly 3,000 of these turbines are now in operation, and their reliability, efficiency and durability have been thoroughly tested in various kinds of service. The aim of the enterprising company has been towards perfection in design rather than cheapening the cost of production. With this in view defects in gland packing and other troubles have been reduced to a minimum. Copies of the Bulletin, No. 20, will be supplied to all interested on application to the company's office, Hartford, Conn.

### Smoke Abatement and Electrification of Railway Terminals in Chicago.

The report of the Chicago Association of Commerce Committee on the investigation of smoke abatement and electrification of railway terminals has just been published, and is reviewed at some length in our editorial column, and, consequently, need be but briefly referred to in this department. The work has been completely supervised by W. F. M. Goss, chief engineer, and is published by Rand, McNally & Co., 538 South Clark street, Chicago. Apart from the voluminous and valuable report, the illustrations and letterpress are excellent. Price, six dollars.

### The New Year.

Ring out the old, ring in the new,  
Ring happy bells across the snow:  
The year is going—let him go;  
Ring out the false, ring in the true.  
—Alfred Tennyson.

## Locomotive Engine Running and Management

By ANGUS SINCLAIR

This popular book has been a **RELIABLE REFERENCE** and comfortable unfailing **POCKET EDITION**.

PRICE, \$2.00

**ANGUS SINCLAIR CO.**  
114 Liberty St., New York

## STEEL STAMPS

**INSPECTORS HAMMERS**  
Hand Cut **STEEL LETTERS & FIGURES**  
**LATHE TOOLS, TIME CHECKS,**  
Noble & Westbrook Mfg. Co.  
9 ASYLUM ST. HARTFORD, CONN.



## The Armstrong Automatic Drill Drift

IS DRIFT AND HAMMER COMBINED.



The handle or driver is always ready to strike a blow as the spring automatically throws it back into position.

LEAVES ONE HAND FREE TO SAVE THE TOOL.

Special Circular mailed on Request.

**ARMSTRONG BROS. TOOL COMPANY**  
312 N. Francisco Ave., CHICAGO, U. S. A.

NEVER SHRINKS OR DETERIORATES



ESPECIALLY PREPARED FOR THE ENGINEER

WORKS EQUALLY WELL ON HOT AND COLD SURFACES  
CLEANS POLISHES and PRESERVES ALL KINDS OF METALS

**GEO. WM. HOFFMAN CO.**

Indianapolis  
New York Chicago San Francisco  
Send for FREE Sample

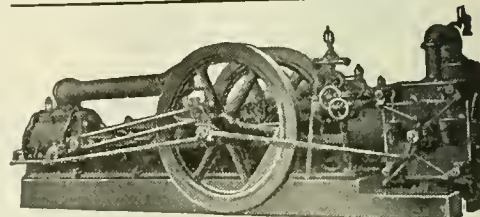

## The Norwalk Iron Works Co.

SOUTH NORWALK, CONN.

Makers of Air and Gas Compressors  
For All Purposes

Send for Catalog

# Railway AND Locomotive Engineering

A Practical Journal of Motive Power, Rolling Stock and Appliances

Vol. XXIX.

114 Liberty Street, New York, February, 1916.

No. 2

## Through Service on the Canadian Northern One Locomotive Hauls the Longest Train Over the Rockies

Perhaps there is no better proof of the fact that a government that is well disposed towards railroad development has a beneficial effect on the development of the country than the vast improvements on the Canadian railways during the last few years, and when we compare this with the depressing effect that the United States Government has had on the railroads within its borders, the results are particularly noteworthy. The progress of the Dominion railroads has been

be found in the Canadian Northern, a transcontinental important trunk line reaching out to practically all of the Canadian centers, and additional branches, running through productive areas in the east and west, connecting the system into one symmetrical transportation machine, with approximately ten thousand miles of track. In its main line from Atlantic tidewater to the Pacific the Canadian Northern has the easiest gradients of any road of similar national importance on

inces of Canada. As may be expected, the grades of the prairie lines are easy, but between Port Arthur, on Lake Superior, and Ottawa and Montreal, where real difficulties were again encountered, and where the chief locating engineer of the company spent four years in exploratory work before the most suitable route was selected, the main line runs with maximum grades of one-half of one per cent. in either direction, or 26 feet of a rise in any single mile. The ter-



SINGLE LOCOMOTIVE HAULING FIFTEEN COACHES ACROSS THE THOMSON RIVER AND OVER THE ROCKY MOUNTAINS, BREAKING THE RAILWAY RECORD IN AMERICA. WEST BOUND GRADE 26 FEET TO THE MILE. EAST BOUND GRADE 37 FEET TO THE MILE.

phenomenal. In the United States one-third of the railways are in receivers' hands, and the other two-thirds praying for some measure of relief. It is hoped and believed that the Canadian government will continue its policy of encouraging railroad enterprise. In the United States we are hoping against hope, and have occasional gleams of assurance that the pernicious effects of governmental repression cannot much longer continue.

A striking example of the rapid development of the Dominion railways may

be found in the Canadian Northern, a transcontinental important trunk line reaching out to practically all of the Canadian centers, and additional branches, running through productive areas in the east and west, connecting the system into one symmetrical transportation machine, with approximately ten thousand miles of track. In its main line from Atlantic tidewater to the Pacific the Canadian Northern has the easiest gradients of any road of similar national importance on

the continent of North America. It has pierced the Rocky Mountains with a line which presents no greater obstacles for its locomotives to overcome than a rise in any one mile of 35 feet, and that applies over a short division only. The interprovincial trade between British Columbia and the Central prairie provinces is rapidly increasing since the opening of the Panama Canal, and one locomotive suffices to haul a standard train over the mountains which wall off British Columbia from the eastern prov-

vincial facilities in all the important centres served are adequate and convenient, and it is but a step from the trains at either Montreal or Quebec to the decks of the Canadian Northern Atlantic "Royals"—R.M.S. "Royal Edward" and R.M.S. "Royal George." At Port Arthur the Canadian Northern grain elevator, with a capacity of 10,000,000 bushels, is the largest plant of its kind in the world.

The Halifax and South-Western Railway, in Nova Scotia, requires no introduction to the people of the Atlantic sea-

board States, as the resorts along "the Line by the Sea," as the road is popularly known, have a yearly acquaintance with Americans from as far south as Philadelphia. The lines of the company in Ontario and Quebec traverse the widely-known Laurentian, Rideau Lakes and Muskoka Lakes Districts, and connect the chief cities, such as Quebec, Montreal, Ottawa and Toronto. They have opened up the famous Nipigon country, and go through the summer grounds in the Rainy Lake region, which lies between Port Arthur and Winnipeg. On the prairies, C.N.R. lines serve nearly all the important centres, such as Brandon, Regina, Moose Jaw, Calgary, Edmonton, North Battleford, Prince Albert and Saskatoon, apart from a host of intermediate municipalities, and the chief remaining cities—Medicine Hat and Lethbridge—are included in the construction programme of the immediate future. Jasper Park, at the gateway to the Yellowhead Pass, set aside by the Dominion Government, is served by the transcontinental line, which continues westward through magnificent mountain scenery, and down the valleys of the North Thompson, Thompson, and Fraser Rivers to the sea—a water level route through British Columbia.

Transcontinental service was recently inaugurated on the Canadian Northern Railway, the first through train from Vancouver to the east leaving this port last month. This is the third railway in the Dominion to establish a regular ocean to ocean service, the first being the Canadian Pacific which has maintained a transcontinental service since 1885. The Grand Trunk, with Pacific terminals at Prince Rupert, British Columbia, was completed and a through service established last summer. The Canadian Northern, the last of the Dominion railways to enter the list of competitors for transcontinental business, has its terminals in this port. The Grand Trunk will also have railway terminals in Vancouver, and connections with the main line over a branch road now in the course of construction. At present the Vancouver connection is by steamer service with the company's fleet operating between Vancouver and Prince Rupert.

#### Duration of Steel Bridges.

Mr. J. H. Ames, at the Northwestern Road Congress, said that the probable life of a steel bridge is a point of serious consideration, if this type of construction is to be generally used. The life of the steelwork will depend almost entirely upon the attention it receives from the maintenance forces. If properly painted with a good quality of paint there is no apparent reason why the life of a well designed steel bridge may not be very great. From observation of properly

painted steelwork it is believed that under ordinary conditions our present riveted steel structure or I-beam spans should have a life equal to, if not greater than, much of our present concrete construction. To attain a life of even twenty years the steelwork must often receive attention, and corrosion must be checked before it seriously affects the metal. With the general tendency towards more efficient supervision of highway work we are able to provide greater assurance of prolonged life to our metal structures in the matter of keeping them properly painted and in repair. The elimination of details not easily accessible for painting, and the demand for more durable paints, have both tended to increase the general use of steel structures. The annual depreciation and maintenance charge need not be high if the steel receives the proper shop and field coats before erection, and if it is given the necessary attention after erection.

#### The Quebec Bridge.

Mr. H. P. Borden, assistant to the chief engineer for the Quebec Bridge, says that if the programme of work as outlined is carried out it will be possible to run trains across the bridge at the close of next season. By October the great suspended span, which is 640 feet long, and weighs 6,000 tons, will be floated to its place. This great undertaking was begun nearly eight years ago by a private firm. Subsequently the bonds of the company were guaranteed by the then Government. During its first construction the bridge gave way, and some 95 people lost their lives. The Quebec Bridge was one of the legacies inherited by the present Government. When finished it will have cost some seventeen million dollars. It was at first calculated that the bridge could be built for six million.

#### Bolivar-Amazon Railway.

The surveys of the important project, the Puerto Bolivar-Amazon Railway of Ecuador, are nearly complete, the staking of the line from the coast, at Puerto Bolivar, to a point 37 miles beyond the city of Loja having been accomplished. The chief engineer states that the first section is nearly straight to Machala, continuing to Santa Rosa, thence to Torata Pass, and ascends the hill at Garanta de Piñas. From there it descends to cross the Colera, Amarilla, Luis, and Embocas Rivers, rising to the pass of Santa Ana, whence it descends to a point 85 miles from the coast. At least eight tunnels will be constructed within five miles, at a point 75 to 80 miles inland. One of these will be at Toronche Pass, extending 1,283 feet, and another through Cajanuma Ridge, 485 feet. These are the longest.

#### Berlin to Constantinople.

The German Railway Administration has issued the new time-tables for the Berlin-Munich-Constantinople trains. The trains will not go through Belgrade, because the bridge over the Save is not rebuilt and the Ripanj tunnel is destroyed. They will follow the route Berlin-Munich-Budapest-Temesvar-Verschez, crossing the Danube at Semendria and reaching Nish by a secondary line. Thence they will run to the Turkish capital. The first train was announced to leave Berlin on December 23. According to another German message through Zurich, the bridge across the Save between Belgrade and Semlin, the destruction of which by the Serbians was one of the first acts of the present war, has been rebuilt.

#### Robinson's Superheater.

On the Victorian Government railways it has been found that the use of superheaters on locomotives realizes an all-round economy of from 15 to 20 per cent. in fuel.

Before the war a considerable number of the "Schmidt" pattern had been ordered, but the Administration Report of the Commissioners states that as there is "not likely to be any appreciable variation in economy as between the two types, and that as the company controlling the 'Robinson' superheater is wholly British, it has been decided to adopt the 'Robinson' as the standard superheater, and an additional 60 locomotives are to be equipped with superheaters of that type."

#### Degrees of Curves.

Much uncertainty exists among railroad men concerning the sharpness of track curves. In the United States railway curves are nearly always described as so many degrees. In foreign countries so many feet radius describes the curve. American engineers measure curves as part of a circle whose radius is established by the angle of deflection. If the angle of deflection is 1 degree, the radius of the curve is 5,730 feet; 2 degrees is half of that and so on. A 10-degree curve is part of a circle having 573 feet radius. By memorizing the radius of a 10-degree curve any person can readily make a mental calculation of the sharpness of any curve.

#### Long Non-Stop Runs.

The Great Northern Railway, of England, can boast of some remarkable non-stop runs. The longest of these is between Wakefield and King's Cross, a distance of 175¾ miles, a journey usually performed in 190 minutes. The next longest non-stop run is King's Cross to Doncaster, 156 miles in 169 minutes.



# New Railroad Safety Film

## Ready for Exhibition on the New York Central Lines

The first exhibition of a new Safety film, "The House That Jack Built," was produced before a large number of leading railway men and representative mem-



REALISTIC REAR END COLLISION SCENE, IN WHICH THREE CARS ARE TELESCOPED.

bers of the press at a private performance in the Schuyler Theatre, New York, on January 15. It consisted of what is known as a three-reel feature Safety film, and was written and adapted to pictures by Mr. Marcus A. Dow, general safety agent of the New York Central Lines. It will be recalled that Mr. Dow produced a work along similar lines over a year ago, and the great success that attended that production, especially among the railroad employees of many of the leading railroads, induced Mr. Dow to produce something, if possible, still more worthy of their attention. In this second effort he is eminently successful and the unqualified approval of the critical observers of the first production is a guarantee of its popular reception among the lessons to be impressed in the minds of railway men in the growing propaganda of safety first.

Like Mr. Dow's first effort, "Steve Hill's Awakening," it is a story of absorbing human interest, and covers a wider field, illustrating unsafe practices in shops,



CONTINUATION OF SCENE IN REAR END COLLISION.

as well as those involving operations of trains. The most thrilling scene is that of a realistic rear end collision, in which a powerful freight engine hauling a heavy

train is seen to crash at a high speed into another train, completely demolishing a coach and two other cars. This scene is one of startling interest, and anyone uninitiated into the mysteries of film production marvels how such an appalling spectacle of wreck and ruin could be produced otherwise than by an actual catastrophe. Everything is there except the shrieks. The suddenness of the arrival of help in this as well as other scenes, while not exactly in keeping with what we have seen of real disasters, is a stretch of Mr. Dow's imagination quite allowable on the mimic stage, and it would be well if it were possible to imitate it in real life.

Coming to the story itself, Jack Foster, a brakeman, who is a fine type of a man, saves his money and builds a house. Jack, however, has his faults like the rest of us, his fault is chiefly that of carelessness while engaged in his work. The wife overhears the conductor telling Jack that sorrow will some day come to him if he does not stop taking chances. She be-

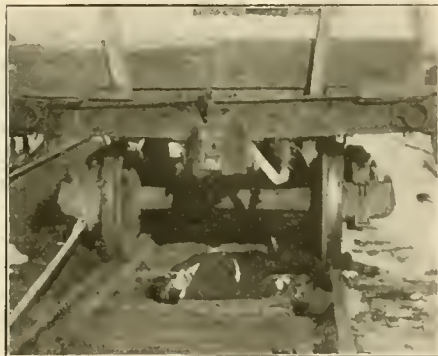

YARD EMPLOYEE HAVING HIS LEG CRUSHED IN THE MOVIES.

comes haunted by visions of what might happen, and the vision comes to her of a train collision due to her husband's neglect in failing to properly protect the rear end of his train by going back a sufficient distance, according to the flagging rule. This is where the most remarkable railroad disaster ever seen in the "movies" is staged. Mrs. Foster hastens to the railroad to allay her fears, and overhears her husband and two men talking. One of them is telling how he lost his leg because his mind was occupied with thoughts of a quarrel he had one morning with his wife. As the story is told the section of the screen shows how the man was knocked down and had his leg run over.

The conductor induces Jack to attend a Safety Rally and a number of unsafe practices in yards and shops are vividly enacted on the screen. One sees the result of leaving nails sticking up in planks left carelessly about where persons might step on them; a shopman is seen to lose an eye because he refused to wear safety

goggles provided for his protection; a carpenter loses a finger while working at a buzz saw with the guard removed from the saw; a brakeman is in a thrilling man-



VIEW OF SHOPMAN WHO RECEIVED A WOUND FROM PROTRUDING RAIL.

ner knocked off the roof of a box car when a coupling is made, because he stood in a careless manner; a brakeman who went between moving cars contrary to instructions fell and his arm was run over in plain view of the audience; an engineman standing between the rails and boarding the footboard of an engine falls under the engine, etc. As each of these scenes appear on the screen close up views of various characters in the audience are shown, their facial expressions depicting the great impression the vivid scenes on the screen have made on their minds. For instance, a one eyed man, viewing the scene in which the goggles are not used, turns to his wife and tells her that was the way he lost his eye; a man with a crippled hand tells his daughter, who sits beside him, that the man in the picture who used the saw without the guard in place paid the same price that he did for his carelessness.

Jack is greatly impressed and on his return to his home he is seen bending over the bed in which his two children are



SHOPMAN RECEIVED INJURY TO HIS EYE REFUSING TO WEAR GOGGLES.

sleeping, and a high resolution comes to him to banish carelessness forever, and Jack becomes the ideal railroad man.

The New York Central Lines will show

this film to the employees of the road and their families in a specially fitted "movie" car, which will travel over the system, stopping at all yards and shops for daily exhibitions. Employees will be required to take the time to witness the film, with the view of teaching them the lessons in safety so impressively brought forth in this intensely interesting and instructive story, and we were much gratified to hear the representatives of other roads promptly bespeak their assurance of special contracts for its appearance in other than the New York Central Lines.

As we have previously remarked on the appearance of Mr. Dow's first effort in this direction, our opinion is that this is the most impressive method hitherto established in conveying the most serious lessons in safety first to railway men. That careless methods have been prevalent among the younger men is painfully evident to all who have had opportunities of observing the celerity with which risks will be taken by the thoughtless young athletes who form the bulk of the younger railroad men, and the statistics collected by Mr. Dow and others who have taken up this matter seriously show a very marked decrease in the list of casualties among this class. Some disasters will probably always remain unavoidable. Such are the happenings on the strenuous work of transportation under any condition, but that it can be reduced to a minimum by appealing to those particularly engaged in the occupation, as well as to that larger body who are by the ties of kindred or association knit to them, by methods at once startling in their realism and appallingly impressive in the lessons that they convey.

#### Elements That Contribute to Success.

A New York City preacher who takes much interest in the careers of young men and labors zealously for their welfare, sent out the following questions for a few prominent business men to answer:

1. What traits are most essential to success?
2. Are we in danger of over estimating ability to make money a mark of success?
3. Which has the greater tendency to break a man down—hard work or worry?
4. Why do many young men fail to make good in business.
5. What bad habits most endanger success?
6. Does a college education help or hinder toward success?
7. Does a religious life add to the young man's general efficiency?

The first question brought forth these answers:

1. Success means securing the greatest real good out of life—not necessarily money or position. I should say that the most essential traits are sincerity, loyalty, gratitude, love of one's fellows, high

ideals and a method by which to attain those ideals.

2. There are a great many essential traits. Most of them can be summed up in one word—dependability.

3. Honesty, loyalty, courage, decision, enthusiasm and tenacity of purpose.

4. Calm persistence is one of the essentials, and due resignation to the will of God another.

The second question brought only one reply, as follows: Many make the mistake of basing success upon ability to make money. Most of the world's greatest successes have been made by men of limited means.

The third question brought four opinions:

1. Hard work is a tonic.
2. Worry breaks men down; hard work seldom does.
3. Worry will wear a man down sooner than anything.
4. No man who believes in God and prays to him worries much.

The fourth question brought four opinions, as follows:

1. Wrong ideals. Superficiality of character.
2. Lack of definite direction.
3. Lack of concentration.
4. Lack of definite purpose.

The fifth question, three replied as follows:

1. Any habit is bad when it interferes with business.
2. Debt, intemperance, bad company and gambling.
3. Drink.

The sixth question brought answers:

1. Undoubtedly. (From two men.)
2. Most decidedly.
3. If it does not make him bigoted and narrow.

Seventh question:

1. Yes, if his religion is real.

#### Explosions in Mines.

"Safety First" is a shibboleth conspicuously displayed in connection with a great many industrial plants, and it is to be hoped that the sentiment will move many concerns to the exercise of care where criminal recklessness now prevails. Among the most fatal accidents that happen in this country are dust explosions in mines, yet mine owners display outrageous carelessness about putting in force the legal requirements instituted to prevent such fatalities.

Despite all Government and State provisions of "Safety First" to prevent mine explosions, it must be admitted that unsatisfactory progress has been made in lessening the number of dust explosions. The observation of Bureau of Mines engineers is that mine managements are not using the means at hand. Out of 100 typical mines examined in one State only 15 were taking any precautions and in

only a few of these had preventions been taken against the ignition of coal dust.

There are some reckless practices indulged in by railway companies, but we know of nothing so reckless as the dangerous apathy of mine owners. Some people object to the supervision put upon railroad companies, but it would be good for the American public if supervision such as prevents railroad accidents were extended to mine owners. We would like to see mine owners prosecuted for manslaughter when people get killed through their criminal recklessness.

#### Growth of Grinding Appliances.

It is a long journey from the crude grindstone of our apprentice days to the elaborate and efficient methods of the present day used for reducing metal by abrasion appliances. The humble grindstone gave place to the emery wheel, so that by 1890 emery wheels performed the greater portion of the abrasion of metals. The abrasion used for years was Turkish emery, which soon was pushed aside by emery from the island of Naxos in the Grecian Archipelago, which for years proved to be the best material for the manufacture of grinding wheels.

An important advance in the manufacture of abrasives was made in 1891 when the Carborundum Company of Niagara Falls put upon the market "Carborundum," which is a carbide of Silicon. Eight years later that enterprising company put upon the market an artificial corundum which they called "aloxite."

The invention of improved abrasives has made very remarkable progress in the last fifteen years for there are now thirty-three plants in the United States and Canada making abrasive devices. Emery, though used to some extent, has been largely supplanted by artificial abrasives, and the carbide of silicon and aluminous oxides of clay or bauxite have come into extensive use. No mechanical operation has come so rapidly into use since this century opened as the construction of grinding appliances.

#### Engineering Expressions.

Reciprocal of a number = unity divided by the number.

Coefficient of adhesion is the reciprocal of the ratio of adhesion weight to tractive power:

$$\text{If ratio} = 3.875, \text{ coefficient} = \frac{1}{3.875} = 0.258.$$

If weight on drivers = 155,000 the tractive power for a coefficient of adhesion as above would be  $155,000 \times 0.258 = 39,990$  + pounds.

Tractive power = 40,000 pounds.  
Ratio of adhesion weight to traction power = 3.875 which gives a coefficient of adhesion = 0.26.

# At the North Shops, Springfield, Mo., on the St. Louis and San Francisco Railroad

The general increase in railroad traffic which is being experienced all over the country, together with here and there a

in the north to New Orleans and along the coast of the Gulf of Mexico to the Rio Grande in the south, with an inter-

purchased, controlled or operated, the most important next to the main line of the St. Louis and San Francisco Railroad, that of the Chicago and Eastern Illinois Railroad is the next largest, extending as it does to 1,282 miles.

The equipment has been maintained at a high degree of efficiency, and the improvements have been continuous and large augmentations to the equipment will be made in the near future. The principal repair shops are located at Springfield, Mo., and since their original construction in 1872 have been greatly added to from time to time. In keeping with the general trend of better instruction for apprentices the class rooms at the north shops seemed to us to be furnished with every appliance necessary for the establishment, while the accomplished apprentice instructor, Mr. C. B. Kerr, showed an earnestness in his work that was calculated to impress the learners with the special advantages provided for them.

It should be stated that a new shop of the most modern type was recently built and which is principally used as a manufacturing plant and for repairing all work equipment, and furnishing parts for other points.

The heads of the departments in the various shops seemed to have become possessed with the spirit of intelligent activity, and were ready for any emergency. Among these were Mr. A. S. Abbott, master mechanic; Mr. J. F. Long, general foreman; Mr. J. P. Malley, general boiler foreman; Mr. M. Christinan, general machine foreman; Mr. J. French, blacksmith foreman; Mr. E. Mitchell, motor car foreman; Mr. R. A. Watson, special equipment foreman; Mr. H. T. Watts, foreman air brake department; Mr. F. W. Allen, erecting foreman, and Mr. S. K. Peters, chief clerk. They were all masters in their way, and the next time we pass we hope that we will have more time on our hands.

### Activity in the Main Shops of the New York, New Haven & Hartford.

The Company's shops at Readville, New Haven and Roxbury repaired 65 locomotives in the month of December, 1915. This compares with a total of 39 locomotives repaired in these same shops in the corresponding month of 1914. There were 23 more locomotives repaired in the month of December than were awaiting repairs on the first of the year. Less than 4 per cent. of the Company's locomotives were in need of repairs on the first of the year. This is considered in railroad circles a very limited number



VIEW SHOWING ROUNDHOUSE AND SHOPS OF THE ST. LOUIS AND SAN FRANCISCO RAILWAY, SPRINGFIELD, MO.

limited increase in rates is having a marked effect in every department in railroad activity. The continued depression had a particularly paralyzing effect on portions of the

vening network of branches passing through the richest portions of a dozen of states, the prospects are now of the brightest, and if the present activity con-

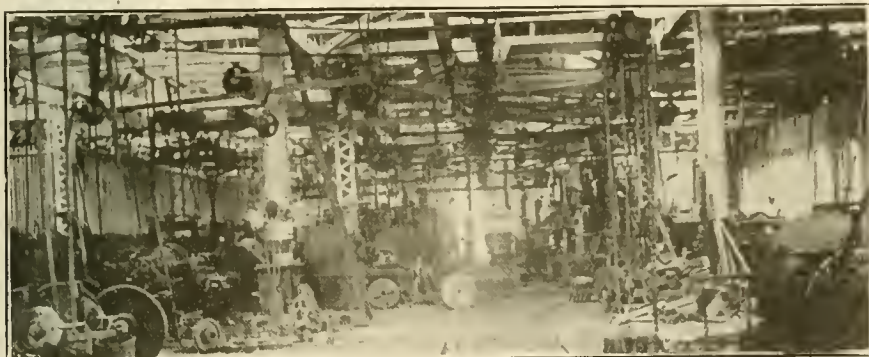

VIEW OF MACHINE SHOP.

west and southwest, with the result that during the last five or six years the additions to the mileage of many of the railroads in those sections of the country al-

times, as it bids fair to do, the rapid development of large portions of the districts referred to cannot fail to be realized.



VIEW SHOWING THE ERECTING SHOP.

luded to were extremely limited. In the vast territory traversed by the St. Louis and San Francisco Railroad Company's System, extending as it does from Chicago

The road at present with its subsidiary branches extends to 5,254 miles, with 896 locomotives and 34,128 cars in service. Of the twenty or more contributory roads,

# Proposed Standard Braking Ratio for Passenger Cars

By **WALTER V. TURNER**, Assistant Manager Westinghouse Air Brake Co.

From previous articles leading up to this subject, it will be seen that as far as train control is concerned, we are dealing with the braking ratio required, desired, or permissible and with all the factors required to obtain the braking ratio determined upon, in which among many other things, brake cylinder pressure is involved. It is evident then that braking ratio is independent of cylinder pressure and consequently the expression is made confusing by mention of cylinder pressure until required and may even be harmful, as is evidenced by the fact that some recommendations as they stand (calling for 90 on 60, 80 on 60, etc.) prohibits the employment of the PC equipment, since it obtains only about 63 per cent. braking ratio on a 60 pounds cylinder pressure, although its maximum service braking ratio is, of course, 90 per cent.

The suggestion to leave off cylinder pressure off the expression when speaking of braking ratio, clears the question of all confusion, and while fixing on some specific figures gives this ratio a definite value and affords a working basis, or starting point, for general brake installations, but even this only affords a means for discussing in a general way the question of braking ratio, its chief merit in this connection being that it is free from the term which misleads, misleading because it must give the impression either the cylinder pressure is indispensable to the expression of braking ratio, or, that by its statement the expression is made full and complete, or both these, whereas, as a matter of fact, in neither case is it so.

With regard to the suggestion that 90 per cent. braking ratio, obtained by a 24 pound reduction in the auxiliary reservoir pressure, be recommended as the most logical, I may point out that it is not the writer's intention to inquire fully into the question as to whether or not the long used and generally accepted 90 per cent. braking ratio for service applications is either the scientific percentage or the best practicable percentage. Personally I believe this to be the case and can furnish very good evidence that this is so, but whether so or not, it would be a very hard task in the first place to change it, and, in the second, the supplanting percentage would have to demonstrate marked superiority before it would be considered worth while to make the attempt to change, and, certainly, before it would be accepted. This is supposing that the change would be great. If it would not be so, certainly it would not deserve consideration. Briefly, my

reasons for suggesting that 90 per cent. braking ratio be recommended as standard are:

First, 90 per cent. has been a common standard for years, and therefore, requires that sufficient reasons be advanced to justify a change and the writer knows none.

Second, this percentage braking ratio happens to be the critical point for the installation of new apparatus and any recommendation which calls for higher than 90 per cent. braking ratio for a full service brake application would be open to the charge of requiring increased expense and troubles which appear prohibitive.

Third, by keeping the braking power down to 90 per cent. for a full service brake application, it is possible to obtain a safe and satisfactory margin between maximum service and maximum emergency braking ratio. If the foregoing is accepted as correct reasoning, we have then reached a starting point in the endeavor to accomplish the purpose as expressed above, namely that 90 per cent. braking ratio be declared as the standard maximum braking ratio for service applications. If this be accepted, then I would suggest that, with a pneumatic brake, that this 90 per cent. be obtained by the reduction of 24 pounds pressure in the auxiliary reservoir. This reduction to be caused by a flow of air at an approximately uniform rate from the auxiliary reservoir to the brake cylinder, this rate to be such that the time to obtain it will be 7 seconds.

These three requirements cover all that with which we are concerned in the design and installation of the air valves. From these we may go on to the leverage ratio that should be considered standard and the cylinder pressure upon which this percentage of braking ratio should be based, but these are derived factors and not fundamental factors, since the leverage ratio permissible is determined by the car and truck construction and by the kind of foundation brake gear employed; while the cylinder pressure upon which the 90 per cent. braking ratio must be based is determined by various other considerations, such as, type of brake equipment, class of service, etc. I am not concerned with any specified set of figures, and am willing to accept any change in these that shall be shown to have greater warrant than those submitted. The chief concern is the adoption of some criterion or standard that will prevent many of the present vagaries and conflicting properties. In other words, I desire that we may be able to say "that after due de-

liberation and consideration of all the interests, conditions, and other considerations, such and such a standard has been adopted and before you, whoever it may be, can hope for the acceptance of what you propose you must attack the standard and demonstrate that it can be obsolete and conditions improved by the acceptance of your proposition."

Assuming now that 90 per cent. braking ratio is accepted as the standard for service brake operations, the solution of the brake ratio problem, for emergency applications is simple and must proceed along certain definite, and not to be varied from, lines, for only two avenues are open for its accomplishment, namely, (1) by an increase in cylinder pressure, and (2) by an increase in brake piston area.

The method by an increase in brake cylinder volume is susceptible of accomplishment in two different ways—(1) by increasing the auxiliary reservoir pressure until at equalization with the brake cylinder the desired emergency braking ratio be obtained, and (2) by an increase in stored volume to such a degree that at its equalization into the brake cylinder the pressure required to give the emergency braking ratio will be obtained.

As a corollary from these two, it is evident that it may be advisable in some cases and necessary in others that both of them be employed.

With regard to the second, namely, increase of brake piston area, it is plain that to increase the brake piston area by the increase in the diameter of a single piston would change the service standards of ratio and time, and therefore, this is manifestly not a permissible method. We are reduced to the necessity of using an additional brake cylinder of such area, pressure considered, that the desired emergency braking ratio will be obtained.

The conclusion from these statements is that 90 per cent. braking ratio obtained from 24 pounds reduction of auxiliary reservoir pressure once being accepted, the means and method of obtaining the emergency braking ratio is absolutely fixed. Reflection will also show that the quantity of emergency braking ratio may be unlimited, if it be obtained, by an increase of auxiliary reservoir pressure. The practical limit is determined by what brake pipe pressure may be carried. For instance, if 90 per cent. braking ratio was based upon 60 pounds cylinder pressure and the 60 pound cylinder pressure was obtained by a 24 pound reduction it is plain that the pressure carried was 84 pounds, assuming that the 24 pounds reduction produced equalization of auxiliary and brake cylinder pressures. There-

fore, if it was desired to obtain 180 per cent. braking ratio in emergency, it would be necessary to carry an auxiliary reservoir pressure of 168 pounds, equalization again being obtained. If the increase of emergency braking ratio is to be obtained by an increase of reservoir volume (called supplementary reservoir) it is likewise plain that 150 per cent. ratio is

the limit that could be obtained in emergency, for the reason that from 110 pounds reservoir pressure carried, 100 pounds brake cylinder pressure is as high an equalization in the brake cylinder as other requirements, such as ability to release the brake, practical volume permissible, etc., will permit under the existing conditions.

If the second method, namely, increase of piston area, is followed, again an unlimited value in braking ratio is possible, since the area of the emergency brake piston as compared with the service brake piston, may be at any ratio, requiring only that the necessary pressure or volume be carried to give the desired cylinder pressure.

## Electric Drive on a Swing Bridge

By J. G. KOPPEL, Asso. A. I. E. E., Sault Ste., Marie, Mich.

Up to within the last few years, the motive power for the operation of draw-bridges has been done almost entirely by electricity, with the exception of few instances where steam power is used for that purpose.

For instance a draw-bridge which was built about 29 years ago for the Duluth, South Shore & Atlantic Railway, at Soo, Michigan, which is 398 feet long and was operated with steam power, from the beginning till last summer, when the

underground cables and are on the operator's disposal all the time.

So far about the operator's side also. In the former case one engineer \$85, and one boy \$40 per month per shift, plus labor when the coaling was needed and the removal of ashes also. Now two men \$2.65 a day per shift, are handling the bridge successfully.

The attached illustration shows the wiring diagram of the installation in

spokes and the frame are very low, so that a standard pot-head or other similar device was impossible to install.

This difficulty was solved by the construction of a home-made terminal box as shown on the right-hand corner on the same illustration, which consists of a steel box, made perfectly water tight, and the one end arranged with lead sleeves to take the lead covered cables with wiped joints, and the other end with suitable bushings to take the extra flexible rub-

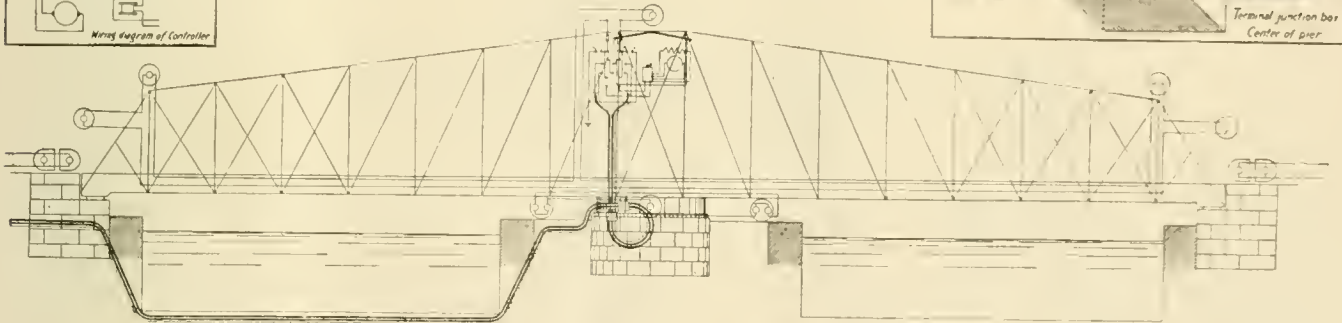
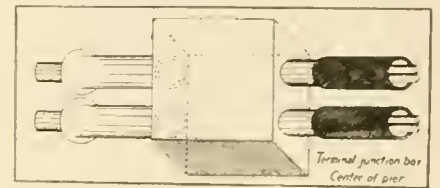
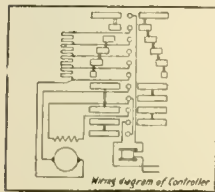

VIEW SHOWING ELECTRIC DRIVE ON A SWING BRIDGE.

steam plant was discarded and electric drive installed, and is in successful operation since; with the improvement that no coal nuisance or water pumping or ashes to handle. The same men who were wearing overalls and leather gloves to handle the equipment, are now in clean clothes with clean faces, answering train calls and operating the bridge without any need of watching the steam gauge or the water columns. Now the power is ready always, which is supplied by the

question; of which only one motor is required for the whole operation. The motor counter-shaft is clutched at both ends, so that with one end the bridge is swung, and with the other end the end-rails are set and locked in position. The wiring was done very simple, with one exception that a special terminal box was required to connect the underground lead covered cables to the extra flexible rubber insulated and armored cables; due to the fact that the center traveling roller

ber insulated and armored cables. The inside was fitted out with slate slabs and drilled for four copper terminals, arranged with thumbscrews to receive the cable terminal lugs on one end, and on the other end the flexible cables, which are coiled in such a way, when the bridge is swung out, the coil uncoils and when the bridge is swung in, that coil recoils.

The motor employed is 43 H. P., and is controlled through 5-point reversible controller from 600-volt direct current.

## Simple Tests for Valves or Packing Blowing

By A. D. CARL, Salamanca, N. Y.

Not every engineer has stopped to think how much time is wasted and how much extra expense the Motive Power Department incurs every year through hasty tests and misleading reports on the work book. It amounts to a nice round sum, and besides if you have a regular engine it sometimes means that you will lose

it for a trip, just because you did not take time to test the engine thoroughly for the blow that gave so much trouble on the last trip.

The tests are simple enough if we only stop and think it over. Why report both valves blowing if it is the cylinder packing on one or both sides? It means

hours of extra work for the roundhouse force unless they have a competent man in the roundhouse who can make these tests and also cause a great amount of delay to engines that should be in service. It takes from five to seven hours to renew a set of cylinder packing on a Mikado engine, and if the roundhouse

force finds the packing all right, they have wasted that much time and we still have the defect which must be remedied.

Now we will place our engine on the right top quarter with the reverse lever in the corner, and open the throttle; but let us first set the brakes. If we get a blow at both cylinder cocks on the left side it is no indication that the valve or cylinder packing is blowing on that side. Now why make a mistake when a little thought and a few minutes' time will tell us just where the blow is. If we get a blow on the right top quarter the best way to find out if it is on that side is to pull the reverse lever to the center of the quadrant while the throttle is opened slightly. If the blow stops when the lever reaches the center we can safely blame the cylinder packing on that side for the trouble. If the blow does not stop with the lever on the center let us try the valve by lifting the cylinder cocks with a stick of some kind, and see how much steam is escaping with the valve in the central position. We should be able to tell just where the blow is almost as well as if we could see the defective rings;

thereby saving time and worry for the roundhouse force, and expense to the company for which we work.

For instance, we will say that we are testing the right cylinder packing. In this position our left engine is taking steam in the back end of the cylinder, and if the rings are down, steam will blow by the defective rings and out at the exhaust. Now the nozzle being smaller than the exhaust passages to the right side will cause the steam to back through the right exhaust passage and in through the open exhaust port into the front end of the right cylinder, and it will show at the cylinder cock as though the packing on that side was blowing.

Now let us place the reverse lever on the center, and, under the conditions I have mentioned, we will get a blow at both cylinder cocks on that side. This is caused by the steam backing through the exhaust passages, and with the valve in the central position we have an opening into both ends of the right cylinder, due to the exhaust clearance. If a valve admission ring was broken or stuck, we would get a blow at the stack and also at

the cylinder cock on the end having the defective ring.

Some engineers complain about a blow when the engine is in a certain position; this is generally caused by a stuck or defective exhaust ring. We have considerable trouble caused by exhaust rings sticking on our superheated engines. We can easily locate the stuck rings. Let us place the engine on the right side on the top quarter; in this position we can get the extreme travel of the valve. Now, if the defective ring is on this side we will not get the blow with the reverse lever in the extreme corner, but when the lever reaches about half the distance to the center of the quadrant, we will get the blow if the defective ring is on the back end of the right valve. Let us test the ring on the front end of the valve in the same manner by placing the lever in the back corner, and gradually pulling it toward the center. When we pull the reverse lever toward the center, we bring the admission ring over the port, and, as the ring is only about half as wide as the port, the defective exhaust ring allows the steam to escape into the exhaust passage.

## The Electric Arc-Welder—Its Advantages and Disadvantages in Flue Welding

### Much Misleading Information in Regard to Its Uses

By C. RICHARDSON, Bridgeport, Conn.

Doing firebox repairs with the Electric Arc-Welder has been of marked benefit to the railroad shop man during recent years; there has, however, been a great deal of misleading information given out from time to time on flue welding. The different makers of the welding machines are no doubt largely responsible for this, as the elimination of leaky flues on the road appeals strongly to all railroad men; holding the flues rigidly to back flue sheet temporarily stops the roundhouse foreman's old-time troubles and annoyances of having to continually work over flues whenever the engine is subject to the usual care to eliminate abuses on the ashpit or on the road.

Eliminating all flexibility at flues and back flue sheet brings about in many instances other boiler troubles that are much more serious than those that were helped. After a short time in service, in some cases only a few months, cracked bridges start to show. The arc-welder can be used for making temporary repairs to these broken bridges; they will not hold for any length of time, however, and before long the cracked bridge condition gets so bad that the sheet must be cut out and renewed after less than a year's service has been obtained in some instances. In some cases the safe ends start to develop longitudinal cracks, also as a result

of welding them to flue sheet, cracks appear first very small, later develop and extend forward past the water side of flue sheet. These flues with cracked safe ends must be taken out and renewed, as there is no way of making effectual repairs.

Various methods of setting the flues have been experimented with to eliminate these failures, flues were set with copper ferrules and without them, some were applied without beads, so that the least possible amount of added thickness would be given to sheet when the flue was welded. None of these arrangements seemed to be of any material assistance in eliminating the bridge cracks. One idea was suggested that at first appeared to be reasonable, scale accumulation between the flues and next to back flue sheet on water side was blamed. It was claimed that the addition of this foreign matter to thickness of material at this point interfered with the water properly cooling the sheet. A careful investigation disclosed the fact that this scale accumulation was evidenced on boilers of exactly same design that had not had welded flues and no resultant cracked bridges.

The writer does not desire to belittle in any manner the great economical advantages of doing firebox repairs other

than flue welding with the arc-welder. Fireboxes of wide-box design that riveted side sheet seams could not be made to hold in have been given part side sheet applications with arc-welded seams with no bother at all being experienced with leaks. The life of fireboxes on these engines has been lengthened at least 50 to 65 per cent. as result. Heretofore when side sheets cracked badly along fire line these boxes had to be renewed.

The arc-welding method has been found to be much more effectual than riveting or using patch bolts and more economical in all ways; many fireboxes have been brought back to life with the arc-welder that would have been cut out and renewed. A new era nearly equaling the advent of High Speed Steel was presented when the present shop man was given the Electric Arc-Welder for his firebox repairs.

It would be gratifying to have the experiences of some of your qualified correspondents on this vital subject, as is usual with all improvements in mechanical details there is much to be learned that does not appear at first sight, and doubtless an exchange of experiences and opinions would add to our stock of knowledge on a subject that is of great and growing importance to railroad men.

# Set of Cutters for Facing Air Brake Pump Valve Caps

By E. L. BROWN, Air Brake Foreman, Illinois Central Railroad

The accompanying drawing illustrates the details of a complete set of cutters for use in facing the upper valve cap and lower valve cage on the Westinghouse

a moderate tightness a few turns of the cutters will brings the seats back to a perfect bearing, and true with the threads, which, of course, is essential to

and carefully tempered. The cost is trifling and if finished to the dimensions given should last for a generation. We always look in the pages of RAILWAY AND

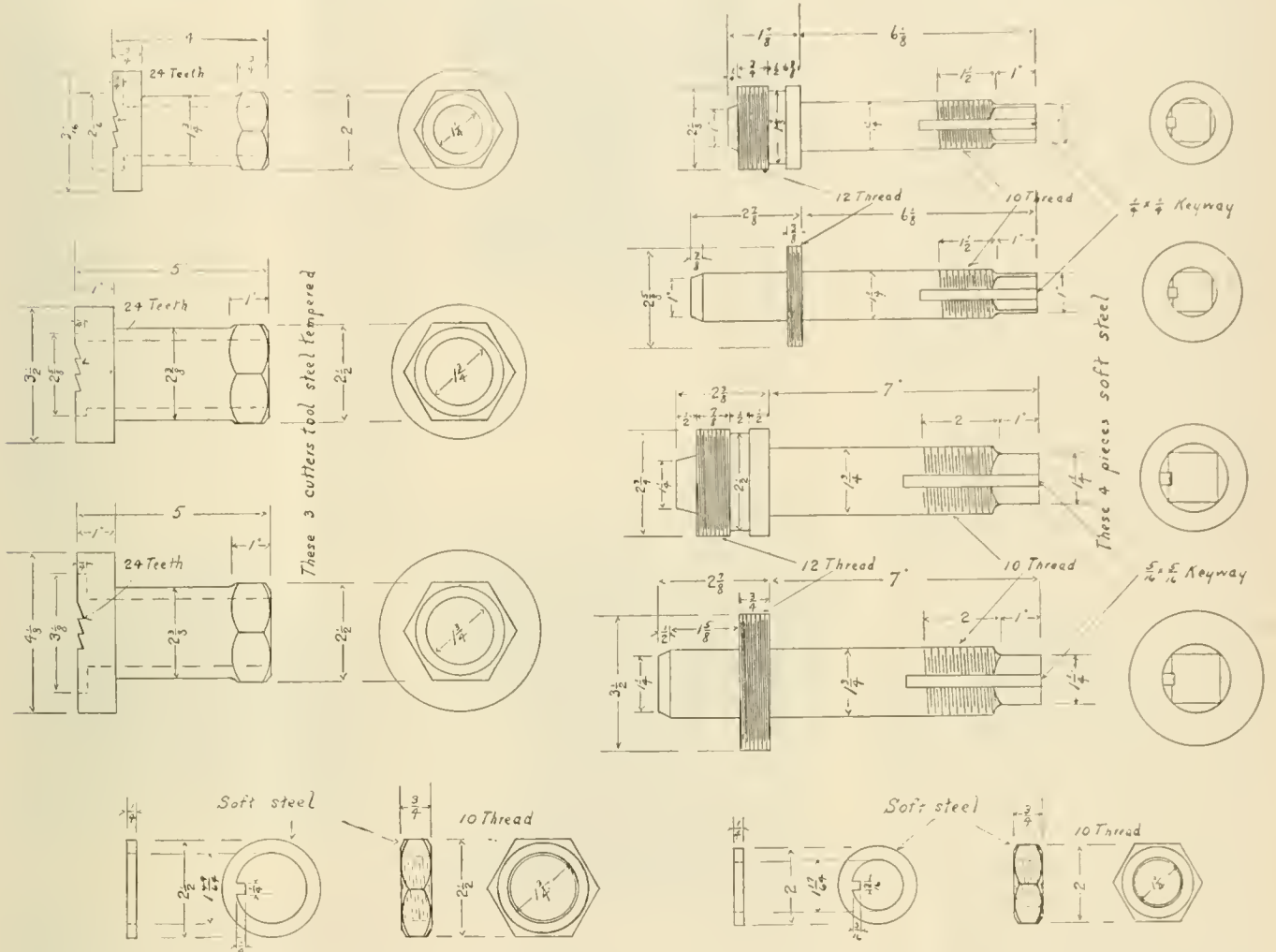

DETAILS OF SET OF CUTTERS FOR FACING THE UPPER VALVE CAP AND LOWER VALVE CAP ON THE WESTINGHOUSE 9 1/2 IN., AND NEW YORK NO. 5, AIR PUMPS.

9 1/2 in., and New York No. 5, air pumps, where the seat is damaged or where a leak may be discovered. By applying the apparatus and tightening the same

the formation of a properly fitting joint. It will be observed that the shanks and nuts may be made of soft steel, while the cutters should be made of tool steel,

LOCOMOTIVE ENGINEERING for the latest details in the locomotive generally and anything appertaining to the air brake particularly.

## Removal and Application of Flues

By G. F. PROUT, Boiler Maker Foreman, Covington, Ky., Chesapeake and Ohio Railway

In describing the details of the removal and application of flues in a locomotive boiler, and estimating the cost of the same, we will take a Class G-7 boiler, which we are the most familiar with. The average G-7 boiler has 363 tubes, and should be .125 x 2" x 14' 9". In removing these flues we cut away the flue bead, which operation is performed by one

boiler maker in three hours time at a cost of \$1.24, the rate being \$.4126 per hour. At the same time the beads are being removed the flues are being cut in front with shop-made flue cutter, operated with a No. 2 pneumatic motor. This operation requires 2 1/2 hours for one high rate helper, .2882 per hour and one low rate helper at .2182, or \$1.27. The flues

are then conveyed to the flue rattlers, taking four helpers three hours each at .2182 per hour or \$2.62. The flues are distributed between two rattlers and cleaned dry in 10 hours, the flue rattler receiving 15 cents per hour or \$1.50. After the flues are cleaned they are cut off preparatory to welding them. This necessitates using one high rate helper 5 hours

at .2882, amounting to \$1.44, and one low rate helper 5 hours at .2182, amounting to \$1.09. The flues are then turned over to the blacksmith shop for welding.

After the flues are removed from the boiler, the flue sheets are examined and necessary repairs made. If needed, the sheets are straightened at an average cost of \$2.32 per boiler. In taking the lengths of the tubes before applying (which is nothing more than getting the length of the water space, horizontally between flue sheets) requires one hour for high rate helper at .2882, and one low rate helper at .2182. Good care should be taken so as not to have over five lengths at the most, for if more lengths than this should develop flue sheets should be re-straightened, as it is very evident that the sheet went back to the old position after removing (strong backs) or vice versa. After getting the length of the flues on measuring stick, we are ready to cut them off to length. This operation requires longer time than cutting them preparatory to welding them. It is necessary to allow at least one-half inch on length to give sufficient stock on each end and to insure a standard bead. These flues are cut at this time in six hours by using a high rate helper at .2882 per hour or \$1.73, and one low-rate helper at .2182 per hour or \$1.31. After the flues are out of the boiler, the flue ends remaining in front sheet are removed and the flue holes in both back and front sheet are cleaned of all foreign substance in ten hours by one high rate helper at .2882, or \$2.88. Copper ferrules are then applied by boiler maker with sectional expanders in 5 hours at .4126, or \$2.06. I find that by using sectional expanders with the same reach as thickness of flue sheet it is much cheaper and makes a much better job in the end than by the old method of driving liner with hammer, after having stretched same, and then rolling the life out of the copper, after which they invariably had to be pinned or belled over on inside in one operation; the shoulder on prosser clinching liner on inside. We are now ready for the application of the flues. The flues are brought to the engine, and put in boiler with one boiler maker at .4126 per hour, one high rate helper at .2882 per hour, and two low-rate helpers at .2182 per hour each. A total of five hours time at a cost of \$5.69. We are now in a position to set the flues.

We first pin the flues with long stroke pneumatic hammer with tool in same especially made for this work, which is operated by one boiler maker who received .4126 per hour, and one boiler maker apprentice who received 17 cents per hour, requiring three hours' time or a cost of \$1.74.

The flues are then belled (or lipped over) requiring one hour's time with the same gang but using a different tool in the pneumatic hammer at a cost of 58 cents. This operation has been performed in fifteen minutes.

The flues are then expanded and prossered. The sectional expander, which is called the prosser, was named after the man who invented same. This operation requires the same gang with the same tools four hours to complete at a cost of \$2.33.

We then give the flues a light rolling with roll expanders and pneumatic motor, operated by the same gang. This work is usually done in 1½ hours at a cost of 87 cents, this operation is done many times in forty minutes.

The flues are now ready to head—which work is completed by one boiler maker in eight hours at .4126, at a cost of \$3.30. (This work has been done in five hours.)

While these operations are being performed in the firebox, one high rate helper is working the front end of the flues. If the steam pipes have been removed, the front end can be completed in nine hours at .2882 per hour or a total cost of \$2.59.

First, the sheet is braced in the shape of a wheel with eight spokes, running out from the hub. These flues are completed to keep flues from creeping or the sheet from moving either way.

Second, copper ferrules are then applied around the flues, if needed.

Fourth, flues are rolled hard with self-feeding rolls and pneumatic motor. As the flues are usually the last work to be completed on boiler we are now ready for test.

The total cost of labor for the removal and application of locomotive boiler tube-flues on class G-7 engines is \$37.09.

#### Old Things Made New.

"I like your paper very well," said an old friendly critic, as he turned over the pages of RAILWAY AND LOCOMOTIVE ENGINEERING, "but there is a good many things described in it that are old as the hills." This might have lacerated our feelings if we had not remembered some reflections made by "Chordal" years ago to this effect:

"The apprentice boy in a machine shop with a fondness for reading trade literature finds in the simple every-day matter subjects of novelty to himself, and in the course of time his mind becomes stocked with material gathered there, item by item, each one as old as the hills to the world but fresh as daisies to him.

"An apprentice boy sits on a block at noon reading a mechanical paper, and is thoroughly interested in an illustrated article on lining up guides. Some old, gray-headed fellow looks over the boy's shoulder, gets a general idea of the illustrations and sneeringly remarks: 'Pshaw, that thing's a thousand years old. Is that what you fellows read about in these papers?' If the boy is smart he will reply:

'I am 14 years old and this is the first I ever saw of this guide business. How old were you when you found it out?'

"When this same boy gets to be, say, fifty years old he may possibly get disgusted with this kind of shop literature, and begin to think that the editor ought to be kicked for putting old things in the paper, thinking that they can be passed off for novelties. He may forget his own experience.

"Professional literature forms the annals of professional progress. The artisan's literature is not and need not be consecutive in any of its arrangements. It presents a series of items, which each individual arranges in his own mind for his own individual annals of progress.

"The real fact is that the literature of the artisan to be of real value must contain repetitions on literary subjects, and there is a fine problem involved in finding out how often a repetition should occur. We have among our readers the apprentice boy, and the old workman, besides the fireman and the engineer, the master mechanic and the superintendent of machinery. Behind them are a mass of other readers who will not suffer from having old stories told in new words. Men forget things so quickly that old memories will stand feeding with the knowledge that is new to the younger generation."

#### Dangerous Locomotive Steps.

A dangerous defect of American locomotives has always been the steps provided for mounting to the cab. If designers of locomotives were obliged to mount a locomotive going seven miles an hour on a dark night they would receive a valuable object lesson on the danger of badly designed steps that would not soon be forgotten.

We do not think there was ever a worse case of defective designing than the step now happily passing away, consisting of a little oval cast iron pad often loose, stuck on the end of a rod and made in such shape as to collect coal and ice. All handles should be at least four inches long from the cab and extending below the corner of it.

Two freight handlers had a shocking time in the yards of the Erie Railroad at Jersey City. They were directed to go to a certain car and bring out a "roan horse." When they opened the car door they were alarmed to find a rhinoceros inside so they hurriedly closed the door and went away for one of the heavy covered vans that heavy animals are transported in. They backed the van to the car door in great dread about handling the wild animal, and then found that the rhinoceros was stuffed.



# The Landis Threading Machines

## Their Characteristics and Adaptability

The growing favor with which the Landis threading machines are being received in many of the principal railroad shops induces us to call attention to the leading characteristics of the machines, so that those who may not have an opportunity of witnessing the degree of perfection at which they have arrived in accomplishing the work for which they are designed may form some idea as to their superiority. The head, which is the main feature of the machine, locks within itself and produces the effect of a solid die, thereby relieving the yoke of all cutting strain. It is opened and closed automatically by the forward and backward movements of the carriage. This mechanism is controlled by means of a trip rod by which an adjustment for any desired length of thread may be obtained. The vises have a horizontal side-wise as well as a vertical centering adjustment. This insures perfect and permanent alignment with the die. The frame is of a box structure, and is cast in one piece. The cone pulley is mounted on top of the ma-

clamp engages the upper side of the dovetail on the back of the chaser. A small

action between the two supports and insures a rigid die.

There are other features which have stood the test of time and shown how thoroughly the enterprising designers have provided for every detail of a machine admirably adapted in every way for the work that it is expected to do. The chasers have an enduring quality hitherto unknown. Their cutting angle is variable and can be readily ground to suit the nature of the material. They are interchangeable, and they require no annealing, hobbing or retempering. The same chasers will also cut both right and left-hand threads, of course, with the added use of left-hand holders.

As to the material, the most exhaustive experiments have been made and the most suitable metals are used throughout, the head being made entirely of steel, and it has also been found that high-speed steel can be used to better advantage than in any other style of die. In brief the design of these machines, the materials of which they are composed, and the element of durability places them as near perfection in general, in particular, and in detail, as

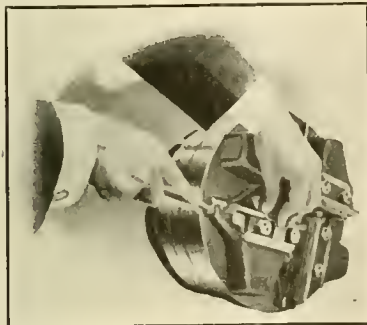
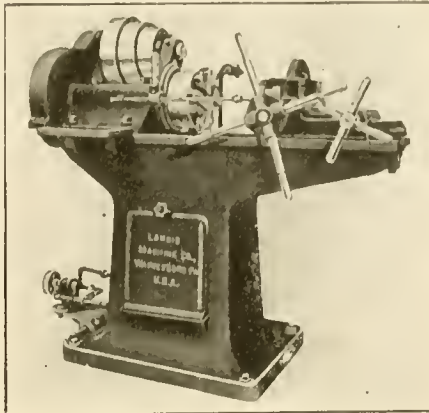

FIG. 1.

chine, and economizes floor space and belting. The gears are enclosed to comply with the factory inspection law, and insures safety for the operator. The lubrication system includes a rotary pump, a by-pass for the surplus cutting solution, and a special control valve at the head. An internal drain located in the main spindle, provides a direct passage to the storage tank for any lubricant which may enter the bore.

The most original and most distinguishing feature in these machines, however, is in the form and position of the chaser in its holder. It will be noted in the illustrations that the chaser is supported close to the cutting edge and is clamped so as to prevent any canting or bell-shaped effect in the die. The chaser is backed at the rear and advanced in its holder by means of an abutting screw. The correct cutting position is obtained as shown in Fig. 1, and is determined by making the zero line on the gauge coincide with the zero line on the holder. Figure 2, shows the manner in which the



LANDIS 1-INCH SINGLE-HEAD BOLT CUTTER. FOR BOLTS AND NUTS FROM 1/4 IN. TO 1 IN.

spring beneath this clamp causes it to release the tool when the screws are slack-

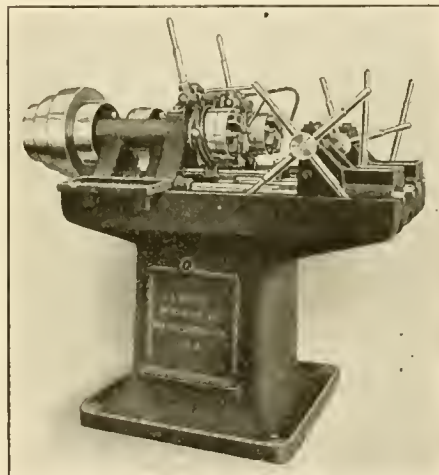

LANDIS 1/2-IN. DOUBLE-HEAD BOLT CUTTER. FOR BOLTS AND NUTS FROM 1/4 IN. TO 1/2 IN.

ened. Each chaser holder is securely fastened to a trunnion and is supported

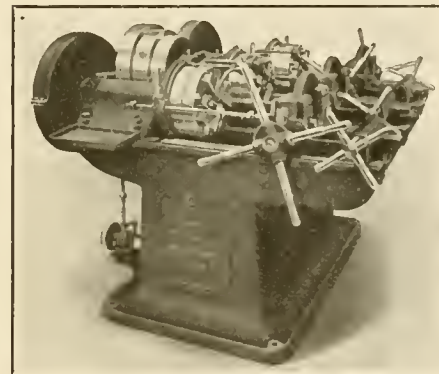

LANDIS 1 1/2-IN. TRIPLE-HEAD BOLT CUTTER. FOR BOLTS AND NUTS FROM 1/2 IN. TO 7/8 IN.

at the outer end by a sliding block. This construction distributes the cutting re-

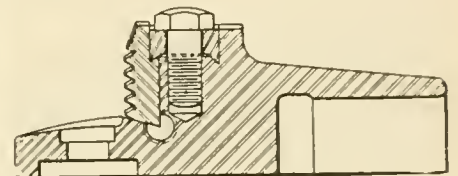

FIG. 2.

anything possible in the realm of high-speed machinery.

### Power of Habit.

We have among our acquaintances a gentleman who always carries an umbrella until it is worn out. He never ventures out without the umbrella, rain or shine. Sheer force of habit prevents him from leaving it when he stops anywhere, a common fete of umbrellas. If an apprentice learning a trade or a fireman engages to maintain steam on a locomotive would adopt a similar plan in the beginning of his career of doing his work in first class shape, he will form habits that will stick to him like the gentleman's umbrella which in later years will bring him large returns. Few people realize the enormous power of habit. The young man engaged in mechanical pursuits who is going to do the next job right, never amounts to anything. The young man who is going to do this job right cannot be kept down. The habit of doing every job right is quite as strong as the habit of always preparing for rain by carrying an umbrella.

# Locomotive Running Repairs

By JAMES KENNEDY

## VI—Leaky Steam Pipes—Their Original Fitting and Refitting Separately Considered

Among the troubles that are to be expected in locomotive operation there are very few more certain of appearing in due time than leaky steam pipe joints and leaky flues. The one seems to follow the other, as if there was some correlation between the separate parts. The cause and effect of these troubles are not far to seek. In the case of the steam pipes, the changes of temperature and the varying pressures to which they are constantly subjected are not only a severe strain on the bolts holding the pipe joints in place, but the pipes and rings are structurally affected by the sheer pressure of the bolts, and in time the lugs of the steam pipes will bend slightly where the continuing pressure of the bolts occur. The occasional tightening of the bolts increases the slight distortion of the rings, and by and by the tightening of the bolts will fail to stop the leaking of the joint, for the reason that the pressure of the bolts will be largely on that portion of the rings adjacent to the lugs, while it will sometimes be found impossible to stop the leaking by the mere processes of pulling and hammering.

When this occurs it is customary to send for the machinist who originally fitted up the pipes, so that he may have the opportunity of being an eye-witness to his alleged incompetency, and walk back to his bench through a valley of humiliation, resolving in a blindly bewildered way to be a better mechanic. It need hardly be said that the machinist is entirely blameless. If the steam pipes were tight at their first trial of steam pressure his work was the work of a master.

It will speedily be observed that when a steam pipe joint is leaking, especially if the escaping steam is blowing toward the flues, the effect on the fire is of a disturbing and dampening kind. A certain number of flues cease to be of any service; the blast of escaping steam, if it be of any considerable volume, will be much stronger than the strongest kind of draft that passes through the flues; consequently, the number of flues affected cease to be operative. The train of evils culminate in the leaking of the flues.

It is not unusual at this period of decadence to send for some overworked boilermarker, when some official, clothed in temporary authority and with an image of importance sitting on his frowning forehead, delivers a short, sharp lecture that is calculated to do the boilermaker good. The boilermaker knows better; but he is accustomed to loud noises, and they pass in at one ear and out at the other.

It should be borne in mind, however,

that the original fitting of the steam pipes is a matter of considerable importance in the reliability of the joints during their period of service. The faces of the joints should be adjusted to stand as nearly parallel to each other as possible. Slight variations in the castings should not be permitted to affect the exact squaring of the joints. Concave bearings and convex rings afford a considerable degree of flexible adaptability, but it is observed that the tendency of the joints to leak is much greater in the case of these fittings where there is an obliquity in the relation of the joints, the leak almost invariably occurring in that portion of the joint where the adjoining castings may be furthest apart from each other.

It will also be found that rings that are comparatively thin have a greater tendency to leak than those that are of more substantial dimensions. In ordinary practice the rings should at least be one inch in thickness. Even the quality of the metal composing the rings is of some consequence in the reliability of the joints, the harder brass or bronze being more likely to resist the bending pressure of the bolts than the softer and more ductile alloys.

When the tendency to leak in the steam pipe joints has become persistently chronic it is good practice to take the earliest opportunity to refit the joints. With proper tools in the hands of an experienced workman the operation is not nearly as serious as it looks. The time occupied in facing the rings in the lathe is time well spent; and it should be noted before taking the steam pipe joints apart whether there are any marked variations in the relation of the joints to each other, as a portion of the face of the bearing on the steam pipe should be removed in order to more properly adjust the bearings to square with each other. This, of course, may necessitate the use of a thicker ring in refitting of the joint.

It should not be expected that the job of refitting can be well accomplished while the locomotive is in a heated condition. All good work requires that it should be performed under good physical conditions, and the most skilled workmen are generally very susceptible to extreme conditions. A careful refitting of the steam pipe joints will in the end be much more conducive to good railway engineering than any amount of repeated efforts to compel joints to remain tight with the application of roundhouse wrenches.

In the fitting or grinding of a steam pipe joint the general practice is to have

cylindrical blocks of wood from four to six inches in length, one end of the block being slightly tapered and fitted so that it will bind itself in the ring without projecting through the ring. On the other end of the block a cross piece of wood may be attached, which may serve as a handle for turning the ring during the grinding process. The application of emery and oil will speedily clean the joint, when the ring and bearing should be carefully dried and rubbed together. The polished parts will show the exact extent of the bearing, and in instances where the bearing shows on two or more separated spots an application of the beveled cutting tool used in forming convex bearings will save time and labor in grinding. In fact, the grinding of steam pipe joints need occupy but little time if the rings and bearings are properly fitted to each other.

In the fitting up of new steam pipes it may be worth while to observe that there is very seldom the amount of care taken that there might be in marking of the exact line of the face of the bearing. It is just as important to draw a line carefully around the entire fitting projection on the steam pipe as it is to mark off the fitting space of the saddle before beginning to remove the superfluous metal. The steam pipe should be hoisted into position with the T-head properly bolted into place. A flat piece of wood, representing the thickness of the ring, should be placed between the two castings and the pipe held in place by a clamp or other temporary attachment. The bottom of the pipe should also be centrally blocked in regard to its relation to the opening in the saddle, and it is good practice to chalk the edges of the bearing strips on the pipes and with hermaphrodite calipers draw a line as nearly as possible all around the part of the pipe to be planed off. This will insure a good beginning and avoid the troubles that naturally arise in all mechanical contrivances where skew bevels are permitted to show their distorted faces. If the faces of the joints are square to each other, and carefully fitted and securely bolted, this is as good as can be, and the work of which the mechanic need never be ashamed.

Spring washers and other devices have appeared and reappeared from time to time, with that degree of tenacity with which exploded theories may be said to be immortal, but they are of no use in securing the bolts, the excessive heat rapidly destroying any degree of resiliency that they ever possessed and rendering them of no service.

# Early Development of the Steam Engine

By ANGUS SINCLAIR, D. E.

The locomotive is one of the most important developments of the steam engine. Very many years have passed since scientific men got to understand that there was something tremendously powerful in steam confined in a vessel strong enough to withstand high pressure. We must wander away back into Greek history some 2,600 years ago to find the earliest speculations about what were the possibilities of steam.

In Alexandria, the Egyptian city, some centuries before the present era, learning had become intensely popular, and a famous savant, named Hero, prepared a manuscript in which an elementary form of steam engine was described. From that time on to the seventeenth century various attempts were made to cause steam to do mechanical work, and a vast amount of speculation was published concerning the possibilities of steam, but no real progress was made until 1710 when Thomas Newcomen, a working blacksmith, of Dartmouth, England, applied a piston to a cylinder, and from that idea originated all the inventions that have made the steam engine the magnificent machine that now performs the world's work. Newcomen's invention was known as the atmospheric engine.

Learned men voiced the speculations as to what steam might be made to do without much practical progress being made for twenty-two centuries, but our opinion is that the housewife used the cooking caldron in such fashion as to keep the world familiar with the terrible possibilities of compressed steam. Loaded with a lump of meat she would put a big pot upon a blazing fire in preparation for the family dinner. To prevent the escape of rich juices she would wrap a cloth around the lid making a steam-tight joint, and put some weight on top. Sometimes the pressure inside the pot would prove too great for the iron to withstand and there would be an explosion, spreading devastation around. Then all sorts of reasons were given concerning the cause of the explosion, the most popular explanation being that the devil had got into the pot. They could never boil a pot very rapidly without wondering if the devil was in it or not. He was a very important personage in those days and to his agency was attributed all the mysterious phenomena that were not understood by ordinary people. The troubles with the boiling pot were afterwards taken up by scientific men, who proceeded to explain that the pressure of steam from boiling water could fracture or force its way out of any vessel.

The first application of steam to perform real useful work was in raising

water out of deep mines. The early attempt to raise water by steam pressure was to put a heavy pressure upon the surface of the water and force it up by that pressure through pipes, but it was a very slow and expensive method. The first real success in doing mechanical work with steam was achieved by Thomas Newcomen, as already mentioned. His invention arranged for pushing the piston upwards by steam pressure and permitting it to descend by the pressure of the atmosphere, the cylinder being open at the top.

Newcomen's atmospheric engine represented, at the time it was invented, the most important and the most useful invention in the world's history, for it gave to mankind the means of transforming fuel into useful work. It made the coal heap the basis of steam engineering.

The first eminent American engineer was Oliver Evans who has the right to be considered the father of the high speed steam engine. When James Watt in Glasgow, Scotland, was working on developing Newcomen's engine into a condensing engine, Oliver Evans a native of Delaware in the United States, built a high pressure high speed engine which became the prototype of American and all high speed motive power. While Watt was striving to force into popularity his slow moving ponderous condensing engine, Evans was offering to the industrial world light non-condensing engines that he considered were more efficient than those built after Watt's patents.

American inventors were much more successful than their European rivals in constructing boilers that were safe under high steam pressure. European inventors seeking to improve upon existing types, used the domestic caldron as their model which was essentially weak. Americans untrammelled by precedent, adopted the idea of pipe boilers, which had great pressure resisting power. Evans used steam of 150 pounds pressure, when Watt was using only 25 pounds to the square inch.

Watt had not been long building his condensing engine, when the leading people of Britain requested that he construct an engine that would propel vehicles on roads. He built one engine for that purpose, but it was a failure and the maker declared there was nothing in that line of improvement. Oliver Evans said there was a great deal in it. We can save steam he insisted by running 150 revolutions a minute thereby getting much power out of a light engine. Evans' engines used about 200 pounds weight per horse power, Watt used about 1,000 pounds and over to the horse power.

In 1780, Evans applied to the legislature of Pennsylvania for a patent on his high pressure steam engine and it was refused. But that did not discourage this great inventor, for to the end of his days he continued to build high pressure engines that were used for mill driving and other purposes.

Poverty prevented Evans from making the success of the light pressure engine that Watt made of the condensing engine; but his voice was heard crying in the wilderness that his engine was destined to perform great services for mankind, and his prediction proved true after many days. He held that his engine was well adapted for the propulsion of ships and to pull railroad trains. Evans was an inventive genius and one of the keen seers of the human race, whose visions penetrated the gloom of the future, but his labor and aspirations were strangled by adverse circumstances. He did not live to see his engine pulling railroad trains, but it was his invention that enabled George Stephenson, Peter Cooper, Matthias Baldwin and others to supply motive power adapted to hauling railroad trains.

## Praise for the Engineer.

A well-known railroad president who rose through the coal scoop, throttle and master mechanic's position to the exalted office he now holds with dignity and undoubted ability, recently discussed several phases of railroad operating with the writer. He remarked: "There is no mistake that the locomotive engineer is every day becoming an increasingly important person in railroad operation. When I was on the road, the engineer received no consideration compared to the conductor. If there was a very important special to be run, when the making of time was of much consequence, the best conductor on the road was selected and upon him devolved the responsibility of getting the train along without loss of time. If the weather was bad, snow deep or unusual difficulties were looked for in getting trains over a division the conductor was looked upon as the man who would do the most in getting there.

"Since there came to be so much machinery on locomotives and cars that the engineer alone is likely to understand, he is getting to be looked upon as the man responsible for everything connected with the safe and prompt movement of the trains. When there is anxiety about pushing a train through under difficulties nowadays we never concern ourselves about who is conductor. If the engineer is a man whom record gives confidence, we know that everything will be done that ability can accomplish."

# Elements of Mechanical Drawing

## May Be Learned Without the Aid of Special Instructors

In the study of mechanical drawing for shop use, contrary to the old traditions of the subject, it is not necessary to struggle through an intricate maze of exercises that are more than likely to never be of service in practical application. The prime need is to cover the elements of the art, since that is the ground work of it, making such use of that portion as has direct bearing on office and shop practice, embracing the theory of projections, intersection of solids and also free hand sketching. Those are the essentials of line language—a working knowledge of which is one of the requisites to advancement in the shop as well as the first requirement to a place in the drawing office.

The object of this article is to show the relation of mechanical drawing to the actual theory and practice of shop application, by the aid of elementary principles and examples of drawing and sketching of objects on a plane surface. In these exercises and conventions care is given to the needs of the beginner from the standpoint of those who are the architects of their own success, and are intended particularly for the advancement of those who may not be in a position to enjoy the advantages of a regular course of study under the care of an instructor.

The representation of an object by lines serves the double purpose of acquiring a knowledge of practical geometry and a proficiency in drawing, and such drawing may be made with the simplest of aids, as a pencil with paper only, or by means of the most expensive accessories. The drawing board receives first consideration in the selection of apparatus to work with, since it is the foundation on which the work is reared, and it should therefore be of thoroughly dry material, well made, true and smooth on all working surfaces, and of white pine, in order to easily take the thumb tacks by which the drawing paper is secured to the board. For the present purpose the board as shown in Fig. 1 may be made 18 by 24 inches, glued up in sections  $\frac{3}{4}$  inch thick and with facing pieces at each end tongued, grooved and glued to the built up body of board; these ends, against which the T-square works, should have the grain running in the direction of their length. On the bottom side of the drawing board is two cleats near each end which are screwed with one screw through each section of the board. The function of these cleats is to prevent warping of the board, and also to raise it clear of working table when in use.

Selection of a T-square is of equal

importance to that of a drawing board, and care should be taken that it is of hard material, as its ability to resist wear and thus retain its truth is dependent wholly on the material in its make-up.

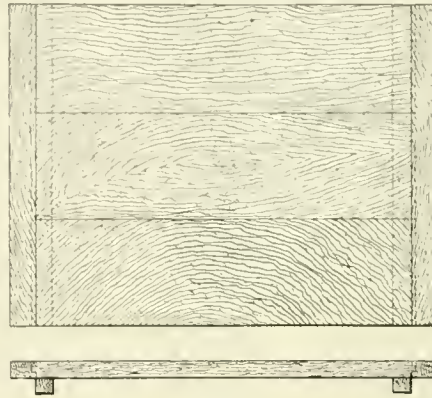

FIG. 1.

It may be of cherry throughout, or have a hard rubber blade and either a cherry or ebony head. The wooden construction is cheaper and furnishes a satisfactory tool, but in any event the blade must

ling, the latter type being convenient for many cases where drawing of lines at an angle is necessary, and also affords a ready means of adjustment for any slight deviation of the board from truth. Fig. 2 shows a serviceable T-square with a fixed head secured to the blade by screws. A blade 24 inches long will be suitable for the board selected.

For use in connection with the T-square and also by themselves for short diagonal or perpendicular lines triangles are used and are usually two in number, but it is more convenient to have four or two of each kind—one large and one small of 45 and 90 degrees, and 30, 60 and 90 degrees. The material may be of wood, hard rubber, or zylonite, as the fancy or means dictate. The zylonite angles have the advantage of being transparent, and thus allow lines under the angles to be visible. A convenient size for the angles is 4 and 8 inches for the 45 degree, and 4 and 10 inches for the 30 and 60 degree. A pair of these triangles is shown in Fig. 2.

A drawing pencil should be hard and

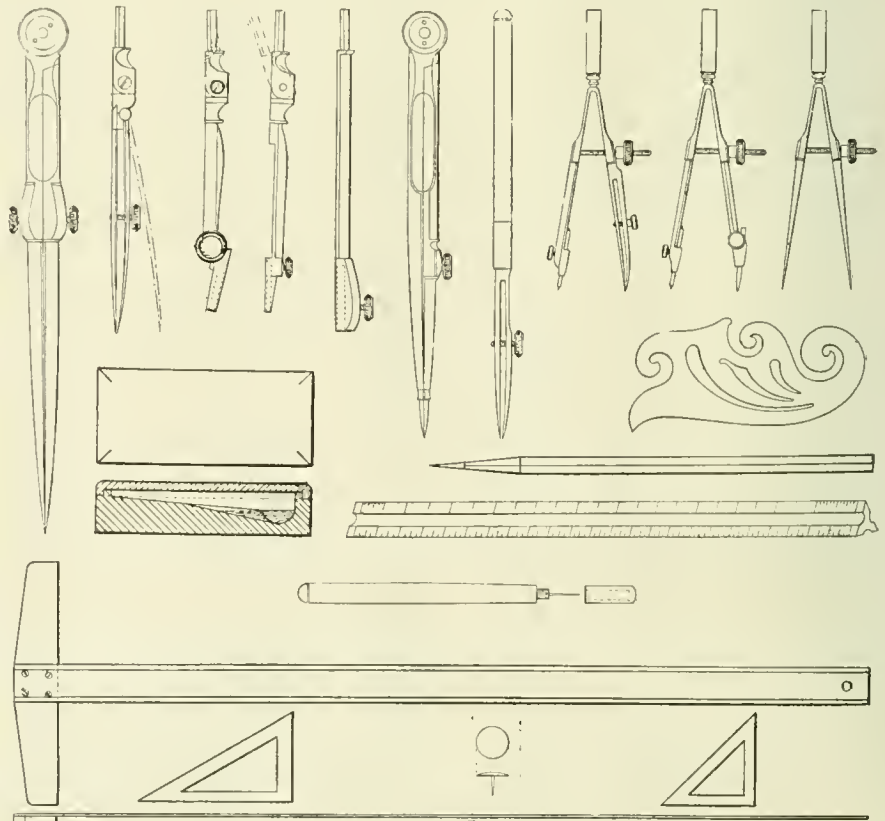

FIG. 2.

have a straight working edge and should not be over  $\frac{1}{2}$  inches wide by  $\frac{3}{32}$  inches thick, with the two edges chamfered on the inside to  $\frac{1}{16}$  inch thick. The head may be either fixed or swivel-

of uniform density, dressed to a round, true point by a sharp knife and finished with a fine file or a piece of fine emery cloth or sandpaper on a flat piece of wood. Such a point will require careful

usage to preserve it, but will stand fatigue well when used with a rotary motion. Its round form facilitates the plotting of dimensions from the scale, and is generally regarded with more favor than the flat knife edge point. There are many good pencils in the market, but the Dixon pencil is well liked for drawing and sketching and are recommended both on the ground of quality and the fact that they may be obtained anywhere.

In the selection of thumb tacks the first consideration is the character of the shank and point and how secured in the head. The best tacks are those with the shank of small diameter, and screwed into head. The advantage of both of these features is that a small sharp point is easier to manipulate in and out of the drawing board, and does not leave a large hole when removed, while the screwed head provides against pushing the shank through into the thumb when putting drawing paper on the board. A thin head not over  $\frac{1}{2}$  inch in diameter is the best size of tack for all work. Such a tack is shown in Fig. 2.

Drawing paper may be had in any quality, but for the purposes of this work an inexpensive article known as manila will prove suitable. Since there are many grades of manila paper; that for the drawing board should be of the heavy quality that will permit of erasures, and will also give a clear, smooth ink line. Such paper can always be obtained and will be fully as satisfactory for this work as the more expensive papers, in fact, such paper is used in many large drawing offices for all classes of work.

In the selection of drawing instruments much care is necessary, not only as to quality, but also in the number. Sets of instruments so-called, such as are found put up in cases should be avoided, except those made by reputable houses, and only those purchased that are actually needed for use, for the reason that instruments are put up in some collections that would never be used in ordinary practice. The better method in getting together the first instruments is to purchase such as have been found to cover actual needs, and find a case to fit the selection. Such a choice embraces a 5-inch ruling pen, a 5-inch spacer, a  $5\frac{1}{2}$ -inch compass with a pen, pencil, and needle point and lengthening bar, also a set of three  $3\frac{1}{2}$ -inch steel spring bows consisting of a divider, bow pen and bow pencil. The large compass with its accessories will take care of as large work as is usually done in general drawing office practice, while the bow instruments will be useful on the finest and smallest work. This collection of instruments is shown in Fig. 2 in separate pieces and also in a case in Fig. 3. A proper care of the instruments demands that they have a case in which to be kept, and it is as much of a neces-

sity as anything in the draftsman's outfit. The case illustrated is one of the best devised for the purpose, for it occupies but little space, can be carried in the pocket, and the instruments are always where they belong, ready for use. In addition to the instruments named, there are shown in Fig. 2 an ink slab made of porcelain or slate, which is used in preparing india ink when inking in the drawing from the pencil construction lines. For laying down dimensions and drawing an object to scale the 12-inch triangular scale will be found the most satisfactory one to use. They are made of metal or boxwood, and are graduated on one edge to sixteenths of an inch, while the remaining edges are lined to represent  $\frac{1}{8}$ ,  $\frac{1}{4}$ ,  $\frac{3}{8}$ ,  $\frac{3}{4}$ ,  $\frac{1}{2}$ , 1,  $1\frac{1}{2}$  and 3 inches to the foot. In laying off dimensions from the scale when extreme accuracy is desired the pricker shown—which is a needle in the end of a suitable handle, and having a cap to protect the needle when not in use—will be found preferable to the pencil point, for the pencil, as shown, has a long, sharp point that will stand fatigue better in line work than in pricking of distances. The irregular, or French curve so-called, is made of thin wood or hard rubber, and is used in connecting points not controllable by the compass. An erasing rubber to be used for erasing superfluous construction lines and also for cleaning the drawing after the inking in is completed will also be a necessary part of the draftsman's exhibit. Such a rubber about 2 inches long by  $\frac{1}{4}$  inch thick by  $\frac{1}{2}$  inch wide will be perfectly satisfactory.

The instruments and materials, as shown or enumerated, are absolutely all that are required to learn mechanical drawing, or to follow it as a profession. An outfit such as illustrated may be obtained for about 18 dollars; with care and right usage it will last a lifetime.

#### Casehardening.

If a deep case is required the article is first casehardened in the ordinary way, and then cleaned and polished bright; it is important to keep all grease away from it after polishing. If, however, only a thin case is required the article is polished in its soft state. It is then embedded in bone dust in an iron box, the lid of which is well luted with clay so as to exclude air. The box is then heated in the furnace until all is red hot throughout, as well as may be judged, the time, of course, being much shorter than is allowed for deep hardening. The box is then held over the surface of the cooling water, the lid loosened, and the whole contents, bone dust and all, quickly tumbled into the water. Any attempts to take the article out with tongs and quench it in the ordinary way would expose it to the air too long and cause an opaque film of oxide to form. So that

it may be said truly here that "Time is the essence of the contract." Above process gives rich brown mottling, though a little experimenting may be necessary to arrive at the best period of time to allow whilst hot to secure a desired result.

#### Drills.

Drills, observes the *Engineer*, that are properly hardened and pointed are often condemned on account of breakage when the trouble should be rightly charged to the drilling machine. If there is any spring, lost motion or backlash between the upper part of the machine and the table, the drill will not begin to cut until the pressure has taken this up, after which the feed will be practically constant until the point of the drill breaks through. As this happens the resistance to the penetration of the drill is abruptly reduced, and any spring or backlash in the parts of the machine will cause the drill to "hog in." The sudden increase in torsional stress which is thus produced frequently causes drills to break.

#### New Coal Pier on the Pennsylvania.

The Pennsylvania Railroad has commenced work on an extensive new coal pier located at Canton Wharves, Baltimore, Md., calculated to handle 20,000 tons of coal per day. Contracts have been let to the Maryland Dredging & Contracting Company, Baltimore, Md., for dredging at the dock and grading the yard for 1,000 cars which will be part of the entire layout; to the Arthur McMullen Company, New York, for the building of the pier and to the Mead-Morrison Manufacturing Company for the machinery. The pier will be 940 feet long and 66 feet wide. It will be built on creosoted piles with a reinforced concrete floor and concrete bulkhead. Space will be provided for loading four vessels at a time. Connected with the pier there will be a thawinghouse for 30 cars and storage bins for coal for local harbor trade.

#### Accidental Prisoners.

John Johnson, while paying a visit to this office, had a pathetic story to relate. He is engineer of a hotel steam plant in New York City, and decided that one of the boilers needed examination, so he removed the manhole cover and went inside. He seemed to increase in size after he got inside for strive as he might he could not get out. He remained there all night and in the morning managed, with lusty help, to get out.

We know of a more serious case, Daniel Murphy, engineer of another New York hotel steam plant went into a boiler one day and seemed to fatten on the job, for in spite of friends nearly pulling him to pieces he stuck fast. The end was that a boilermaker had to be sent for who cut a strip out of the manhole large enough to let Murphy creep through.

# Railway Locomotive Engineering

A Practical Journal of Motive Power, Rolling Stock and Appliances.

Published Monthly by

**ANGUS SINCLAIR CO.**

114 Liberty St., New York.

Telephone, 746 Rector.

Cable Address, "Locong," N. Y.

Glasgow, "Locoauto."

**Business Department:**

ANGUS SINCLAIR, D. E., Prest. and Treas.

JAMES KENNEDY, Vice-Prest.

HARRY A. KENNEY, Secy. and Gen. Mgr.

**Editorial Department:**

ANGUS SINCLAIR, D. E., Editor.

JAMES KENNEDY, Managing Editor.

GEO. W. KIEHM, Associate Editor.

**London Representative:**

THE LOCOMOTIVE PUBLISHING CO., Ltd.,

8 Amen Corner, Paternoster Row, London, E. C.

**Glasgow Representative:**

A. F. SINCLAIR, 15 Manor Road, Bellabonston,

Glasgow.

**SUBSCRIPTION PRICE**

\$2.00 per year, \$1.00 for six months, postage paid in the United States, Canada and Mexico. For other parts of the world, \$2.50, or ten shillings. Single copies, 20 cents. Remit by Express Money Order, Draft, Post Office Order or Registered Letter.

Mailing address can be changed as often as necessary—always give old and new address, and if you subscribe in a club, state the name of the agent.

Please give prompt notice when your paper fails to reach you regularly.

Entered at the Post Office, New York, as Second-class Mail Matter.

**Softening Feed Water.**

A friendly correspondent who is particularly well informed on railway matters, has written asking if we could make an estimate of the extra fuel used by locomotives owing to the heating surface being more or less coated with scale and added is it not possible to eliminate the scale forming impurities? These are questions beyond our capacity for estimating or guessing, but if any of our readers wish to attempt giving answers we shall gladly publish them.

The vicious effects on the heating surfaces of locomotives by hard water is a subject that has been puzzling mechanical men and the chemists ever since locomotives have been put into operation, and numerous remedies have been proposed but the evil is still rampant. These remedies that would help but they seldom receive efficient trials. Purges, scale

looseness, lime neutralizers and other remedies are frequently recommended, tried for a time, then gradually abandoned, is the tale of scale prevention.

Nearly all officials connected with the operation of locomotives believe that fuel consumption is greatly increased by the use of hard water. Yet there seems to be general apathy in the persistent application of remedies. The reason seems to be in the somewhat complex action of the remedies and doubts ensuing from un-intelligent trials whether the remedies applied have accomplished their purpose. The question of saving is frequently ignored owing to the difficulty of placing a value in actual figures of a clean boiler as compared with a foul one.

The subject of impure feed water or scale prevention may be considered under two heads. 1. Will the process tried, accomplish the purpose? 2. Will the results pay? The trouble experienced with hard water used in locomotive boilers, is the forming of scale that prevents the water from promptly absorbing the heat of the fuel gases. This scale is formed by the depositing in a crystalline form of lime compounds, which are present in solution in all waters. This deposition takes place from the destruction of the solubility of the compounds by the heat of the boiler. Certain chemicals may, however, be introduced into the water which will act upon the lime to form other and noncrystalline precipitates. It is these chemicals which constitute the so called "purges" or boiler compounds. The lime is precipitated by their action in a granular or mud like form, which does not adhere to the sheets, unless baked on by carelessness in drawing off the water while the sheets are hot, and which may be readily blown off or washed out as slime.

Next consideration is will the compounds accomplish their purpose? Exact investigations have been made by scientific men on the softening of water, that prove various systems of water treatment to be entirely effectual in eliminating the hardening elements. There are many cheap and harmless chemicals which act on lime salts in water, and always in known and calculable proportions. The precipitates resulting from such treatments form the sludge already referred to and can be worked out, leaving the boiler sheet clean.

In these days of far reaching economy, the question comes up, will the treatment that eliminates boiler scale pay? This question has not been answered with the accuracy which it deserves, but the belief of those best able to judge is that it pays very well.

The expense of the cleaning process is made up of several items and may be quite definitely ascertained. Thus, we have first, cost of chemicals per engine mile, including all expenses of making up and

handling; second, cost of extra washing entailed; third, cost of fuel wasted by reason of frequent washing out at the blowing out on the road. All of the above are on the wrong side of the ledger. Against these we have the saving effected. This is likewise made up of several items, but unfortunately their true money value is seldom definitely ascertainable.

They are: First, saving of coal on account of better evaporation in boiler uncoated with scale; second, saving in boiler repairs; third, saving of delays on the road from leaking flues etc; fourth, obtaining increased hauling capacity by reason of better condition of boiler and the increased evaporation resulting from clean sheets; fifth, fewer days per year in the shop for repairs, the monetary value of which is at times very great; sixth, absence of obstruction to careful interior examination of boiler as to the condition of its sheets.

It is not the purpose of this article to work out the equation of expenditure and savings. To be applicable, it must be done for each individual case, with the data cost at hand. We have merely attempted to point out the elements to be considered, and to attach the position so frequently taken by motor power officials, that it does not pay to carry on laborious processes for the purpose of keeping boilers clean. The indifferent man avoids all labor that is not absolutely compulsory, a spirit responsible for so many boilers being in use that are foul with scale and lime impregnated water.

**Co-operative Apprentices.**

Considerable attention is being directed to the system of handling apprentices at the McComb, Miss., shops of the Illinois Central Railroad. The system consists of three years of what is known as the co-operative system. High school boys over sixteen years of age are engaged as vacancies occur, and are given employment in the company's shops as co-operative apprentices. The co-operative features includes working in the shops half of their time and the remainder of the time in their classes in the high school. They also work in the shops during the usual vacation school period. The boys in the ninth and tenth grade alternate with the boys in the eleventh and twelfth grades, the alternation being weekly, and the numbers in each grade being nearly equal the force in the shops is not materially interfered with.

Practical information is given in the shops by the foreman, or gang foreman, as the case may be. There is a fixed schedule of work governing the periods at each branch of the shop work, of which a record is kept, thus affording each boy an all round experience. Attendance is also compulsory at the apprentice school in the shops, consisting of one hour a day on

the company's time, where instructions are given in reading drawings, free-hand sketching and elementary drawing with a course of geometry. Lessons are also given in relation to combustion, the properties of steam, the co-relation of temperatures in regard to expansion and condensation of steam and kindred subjects.

The public school officials have heartily endorsed the movement, and the boys are enabled with little more than the usual attention to graduate with their classes. In estimating the rating of the scholars, eighteen units are the requirement for graduation, four of which are allowed for work in the shops, and two for apprentice school work. The remaining units must be made in the usual high school course. The system has already met with general approval, and a marked superiority in the boys over what may be called the usual apprentice material is particularly marked. Arrangements are being made to establish the system at other points on the Illinois Central, and doubtless after the results of the system are better known and more widely established it may become universal, because the method of educating the youth of a country in the elements of a general education and coincidentally giving them an opportunity to devote a certain amount of their time to learn some useful trade is surely better than the system generally in vogue of dropping a boy suddenly from the study of quadratic equations and defunct languages to shuffle coal or clean castings or carry planks from place to place. One of the most pathetic spectacles in railroad work is the college graduate entering upon a special apprenticeship. The spirit is there but the flesh is weak. Those who come heroically through the early days of this unhappy period usually make good men, but it entails all the agonies of the sufferings of the early martyrs. Those who have had the opportunity of looking at the hands of those soft-skinned embryos did not require to be a palmist to know that whatever their future may be the present was full of muffled misery, and the heavy blows of circumstance showed themselves on the peeled knuckles and the repercussions of the heavy hammer opened up the tender lines on their blistered palms, and while the so-called line of life might be long it was also deep, and while, as the palmists usually declare, that the right hand makes money and the left hand gives it away again too easily, surely the penance might be to some extent avoided, and we are already convinced that whoever suggested the sensible plan of co-operative apprenticeships as practised in the McComb shops of the Illinois Central future generations should arise and call him blessed.

In the meantime the plan is not only worthy of imitation, but is the best that we have heard of.

### Dr. Angus Sinclair on Development of Railroad Operating.

For years after railroads were put into operation, the lines under one management were nearly all short, 100 miles being about the maximum length. Such lines were managed almost entirely from the head office, all rates for passengers and freight being arranged by the management which took care that the charges should not deviate from the legal or established schedule.

In the control of train movements the station agents exercised considerable influence. They controlled the loading and unloading of freight and were at liberty to delay trains while freight was being handled. All trains were run on schedule, but station agents were at liberty to accelerate or delay train movements and they enjoyed the privilege of deciding how many cars should be placed upon any train. For years each train had to take along all the cars ready for movement and it was a common occurrence for engines having to double on every hill they came to, a practice which tended greatly to demoralize the traffic.

This condition of operation led to the appointment of a train inspector who decided the load each engine should be called upon to haul. As the cars varied greatly in capacity, this inspector decided upon the loads being hauled by the various locomotives. On some railroads the inspector was called train master and later superintendent.

The superintendent performed a variety of duties that had not previously fallen upon the station master or the train master. In most cases he was responsible for the proper operation of the railroad, not only for the regulation of train movements but for the work of all railroad employees being properly performed. The station agents continued to decide on what rates should be charged for passengers and freight, but when any dispute arose between passengers or shipper with the agent, the superintendent settled the matter. Unless the question was of sufficient gravity to be appealed to the head office.

On nearly all railroads the machinery department was managed separately from the operating department and the master mechanic or locomotive superintendent had entire charge of his own force and was responsible to the general manager. When the responsibilities of the division superintendents came to be clearly defined, they had supervision over the workmen engaged on the maintenance of way which was shared to some extent by the engineering department. In fact before there were regular superintendents the civil engineers acted to some extent as supervisors of trains and traffic operations; but by degrees the engineers' duties became curtailed to the engineering department proper which included care of track, bridges and buildings.

In great Britain, where my longest experience in railway work was gained, there were no diversity of rates for passengers or freight. A regular schedule of rates was established by the management under government supervision and no deviations from that schedule was attempted. I never heard of rate cutting on European railways, which prevented the business complications that became common in the United States.

I had a few years' experience on a short railroad in New York State that was in a position to compete with other lines, and then the rates were fixed by the superintendent who habitually attracted business by giving rates lower than those charged by competitive companies. Then the superintendent was supreme, and the prosperity of the company depended upon his energy in securing business. I had heard him accused of being unfair and he replied: "Fair men be damned, I must have the business."

Such sentiments became widespread by degrees and led eventually to state and government control of rates. As consolidation of mileage resulted in railroads being very long, the superintendent lost the supreme authority he exercised on the shorter lines but his position as a rule has become more comfortable and his responsibility more limited.

### Designs of Boilers.

In these days of high speed, heavy trains and long runs, the locomotive boiler is a very important factor in railroad economy. No matter how good the engine may be, its efficiency is decreased to a great extent by an inferior and especially a leaky boiler.

The chief requirements of a boiler are: (1) that it should be amply strong in all its parts to withstand the pressure to which it will be subjected; (2) that it should provide an abundant supply of steam for the cylinders of the engine it is attached to; (3) that it should do this with the least possible expenditure of fuel; (4) that it should be of such design as to admit repairing cheaply and readily; (5) and that it should be easily kept clear of scale and sediment besides being easily inspected.

First cost within reasonable limit is a minor consideration, that should not be allowed serious consideration, for, broadly speaking a locomotive boiler cannot be too good.

The cylindrical part, or waist, of the boiler can easily be constructed to stand the maximum strain coming upon it with a fair factor of safety—say, five, which is good practice. It is only a question of good plates of the proper thickness, a strong seam and honest workmanship. As soon as the boiler is put into service, however, deterioration begins, and it is the retarding of this as much as possible that should be considered in the design. There is no

doubt whatever that when a butt joint is used corrosion along the seam is much less than with the lap joint. Why this should be true is not altogether clear. The most plausible hypothesis is, that with the butt joint the strains due to the steam pressure is uniformly distributed over the whole circle, while with the lap joint when the boiler is under steam there is a tendency for the plates to straighten out, the result being that the sheet bends to some extent on each side of the lap. This tendency causes scale that may be deposited to flake off leaving the surface of the sheet exposed to furrowing and corrosion. Another theory is that chemical action takes place more readily when a sheet is subjected to a high tensile strain, which is quite reasonable. Although a lap joint can be made as strong as a butt joint yet the established fact that a butt joint is less susceptible to corrosion than the other kind warrants its adoption more especially for large boilers, or for boilers designed to carry high pressures.

The firebox end of the boiler is where the greatest danger lies, and it is this part that claims the major share of attention of boiler designers. Sheets that require severe flanging, such as the throat sheet and top connection on flat wagon top boilers, should always be made 1/16 inch or 1/8 inch thicker than the others, so as to make up for the thinning out arising from the operation of flanging.

The most troublesome things about a locomotive boiler are broken stay-bolts, and every increase in the size of boilers witnesses increased danger from such stay-bolts. As is well known, stay-bolts usually break close to the outer sheet, and may generally be found broken in the two or three upper rows along the sides, except towards the ends of the box where they extend down as far as the sixth or seventh row from the crown. The cause of this breakage is generally understood to be due to the constant bending backwards and forward caused by the difference in expansion between the sheets. There appears to be no remedy for this troublesome condition unless the ball and socket joints prove effective.

A very important consideration in boiler design has been the means employed to support the crown sheet. When the feed water was free from substances that deposited sediment, the crown bar was the most satisfactory means for supporting the crown sheet, but in regions infested with scale and mud depositing water the radial stay has become the most satisfactory sustainer. At first considerable apprehension was felt as to the security of the radial owing to the angle at which many of them must pass through the sheets, but that line of weakness has been overcome.

### Government Control of Railroads.

There was once a tremendous clamor in the United States, because a powerful railway magnate was reported to have used the expression, "the public be damned," but the wrath generated was not long lived, and many of the railway managers kept on treating the public as if they had no rights that the owners of railway property were bound to respect. That practice and policy gradually promoted the growth of an anti-railroad sentiment, which threatened to put all of the railways in the country under government ownership.

Mr. Seth Low, President of the National Civic Association speaking on the Railroad Problem said:

"If government regulation falls short of being as effective as it has fortunately been in the ending of rebates, the tendency toward government operation, despite all its difficulties and dangers, is not unlikely to grow, unchecked. If the railroads wish to escape public ownership they must consent to the public regulation, for the future, of the issue of stocks and bonds; and it is greatly to be hoped that instead of placing every imaginable difficulty in the way of such legislation, they will cordially co-operate to see that effective and fair legislation to prevent the repetition of the abuses of the past is quickly made a part of the law of the land.

If not completely, still very largely, the actual management of railroads in this country has passed, and is constantly passing out of the hands of financiers into the hands of practical railroad men who are less and less affiliated with the stock market. It is reasonable, therefore, to hope that we are passing out of the old era into a better order of things. The practical question also arises whether it is not better now to "let the dead past bury its dead" and to turn with united and courageous front towards the better future. An attempt to uncover all of the past, and to try to do ideal justice now for wrongs that were committed long ago, is certain to be very costly to the country as a whole, as well as to the unhappy stockholders, who, without personal fault, find themselves involved in such a predicament. Mr. Evarts used to say that "there are vested wrongs as well as vested rights," which was a wise man's way of saying that some wrongs are so costly to undo that it is better to leave things as they are and turn over a new leaf.

"There is one aspect of public ownership and operation which it seems to me legitimate to point out to the railroad employees who are so largely represented in our membership, and that is its probable effect upon wages. Railroads that are publicly owned have available for wages only such sums as are appropriated by law. In a country of the vast

extent of the United States that this difference is substantially certain in wages, as established by law, when they have once been fixed. Working conditions will also then be much more difficult to change than when the railroads are under private management. The cost of living is so different in different parts of the United States that this difference is substantially certain to be reflected in an average wage below that which the railroads can pay under private management. The agricultural interests of the country are enormous, and one of their greatest difficulties comes from the fact that agriculture cannot afford to pay as large wages as transportation and many other occupations pay now. This is, in fact, one great reason for the high cost of food products, that agriculture cannot command the labor it needs in order to cultivate as it should, and to produce and to harvest larger crops. As long as railroads are privately owned, agriculture must take its chances; but, in this country, if railroads were publicly owned, the granges and other combinations of farmers would certainly be on the job to keep railroad wages as low as possible. They would have to be or they could not work their farms at all. There is a rigidity about law that makes it difficult to change conditions once established; and it is equally hard, under the provisions of law, to take into consideration local qualifying conditions. Such considerations as these satisfy me that railroad employees are not only better off now, under the private administration of railroads than they would be likely to be under public administration, but also that under existing conditions they can hope for a betterment in pay and rules of service which it would be vastly harder to realize from a Federal government constituted like ours."

### Strength and Weakness of Boilers.

It is almost impossible to make the ordinary boiler user realize that a boiler which has been in operation for years with safety is gradually or rapidly approaching a condition when it will be dangerous to those coming in contact with it. When an owner first puts a boiler into his premises he is nervous every time he hears the steam blow off lest the noise indicates a coming explosion, but familiarity with the noise gets him over that feeling, and then it breeds the contempt which ignorance is ever ready to embrace.

Most of our states are painfully in want of laws to regulate the control and inspection of steam boilers, but public opinion is slow in making the demand that leads to the necessary law making, although possible examples of killed and wounded from boiler explosions are sufficiently numerous to stir people with any feelings of humanity to compel remedies.

Laws requiring thorough and system-



atic investigations of all boiler explosions by expert inspectors, and the publication of the facts, would do a great deal to prepare for effectual remedies and to stop the murders that result from the reckless carelessness of many boiler users. It is not necessary that expert specialist inspectors be employed, men who must be brought in from outside the state where a boiler to be examined is stationed. An intelligent boiler maker employed upon other work belonging to his trade may act very efficiently as a boiler inspector when boilers have to be examined.

The Railroad Commissioners of the State of Massachusetts, who are noted for the conscientious way they perform their duties, used their influence in the enactment of a law requiring all locomotive boilers to be periodically inspected and tested. Most of the railroad companies considered that law a hardship at first, but most of them soon recognized that the law was a blessing in disguise. The boilers are inspected regularly at trifling expense, and the territory so controlled has been celebrated for its exemption from boiler accidents. Defects of a dangerous character are frequently discovered by the inspectors and accidents prevented. If the system of boiler inspection prevalent in Massachusetts were practiced all over the United States, much death and suffering resulting from boiler explosions would be prevented.

There are many people who still cling to the delusion that there is some mysterious force at work which causes boilers to explode. This belief is cherished with child-like faith, more especially among people who are using boilers with ignorant men in charge. It is in their interest to believe or profess that accidents to boilers are mysterious dispensations of Providence and with their interests moves their opinions.

Two well-known facts give strong testimony in favor of the value of thorough and systematic inspection of steam boilers. One of the structurally weakest forms of boilers owing to its awkward shape is the Scots boiler, used on nearly all British ocean steamers; one of the strongest forms of boiler naturally is the locomotive. Although the Scots marine boiler is very extensively used, there is scarcely any instance of such a boiler exploding when inspected under the rules of the British Government. The boiler that explodes most frequently in this country is the portable locomotive boiler used with threshing machines. Inspectors never disturb the comfort of the owners of the common portable boiler.

#### Facts Concerning Heat and Steam.

A very important feature in the operation of steam is to use it in such a manner as to obtain full advantage of its expansive power. Engines working the steam full stroke, and consequently performing

no work through its expansive force do their work at the expense of enormous waste of heat, for practically they pass all the heat transferred from the fuel to the water in the boiler through the exhaust. The economical thermal efficiency of an engine operated in this manner is about as low as can be. The steam does its work in the cylinder by sheer pressure of the densely compressed volume crowding out of the boiler. Worked in this fashion the action of steam on a piston resembles the action of water upon a hydraulic ram, when the water is forced against the ram by the action of the pump behind it. Steam passing from the boiler without expansion to the exhaust by way of the cylinder resembles a stream of water rushing through a turbine, with the exception that the turbine takes some work out of the water by reduction of its velocity, while in the case of steam its full potentiality for work is present at the instant of its release.

It used to be the case that many practical engineers professed contempt for the theories or science on which steam engineering is founded, but the spread of engineering education is pushing such men out of influence. "Knowledge is power" is an ancient proverb whose truth never was so strongly apparent as it has been among the workers who have devoted thought and labor to improving the steam engine.

Numerous insuperable obstacles stand in the way of admitting steam without loss of heat or diminution of pressure into a cylinder made of conductive materials or to exhaust it without back pressure; but to render clear certain calculations respecting the manipulation of steam, it is convenient to assume that certain impracticable operations are possible. Many valuable and interesting laws, facts and figures relating to the behavior and action of steam which the engineering world accepts as being absolutely correct, could not be demonstrated with any degree of accuracy in the ordinary practical working of the steam engine. They are the discoveries and calculations of accomplished physicists and mathematicians, who have devoted laborious and skilful special investigation to the subject aided by ingeniously designed apparatus. In studying out questions relating to heat and steam, the engineer has often to accept as implicitly as he believes the multiplication table, formulas and tables of data given in hand books which he has no means of verifying. Facts, figures and tables about heat and steam that excite but little attention from the men daily using them are in themselves monuments of assiduous and accurate scientific labor, built up by eminent men who have devoted life-long efforts to the investigation of Nature's laws. Among the physicists and mathematicians whose names are identified with the investigations bearing directly in

steam engineering are many whose existence is merely an abstraction to the ordinary engineer, yet their labors have materially lightened his work, and supplied him with data for calculations that enable him to measure heat as accurately as the farmer measures his corn.

#### Speed of Woodworking Machinery.

There seems to be small effort made to instruct the mechanics in railroad planing mills anything about the science of their business, yet there are many interesting things to be learned concerning woodworking machinery, things that would astonish many master mechanics.

Woodworking machines require great power to drive them owing to the enormous capacity for doing work. Wood is more easily worked than metal, but the material is cut so rapidly that it represents immense concentration of power.

A properly driven circular saw has a peripheral speed of 7,000 feet per minute—nearly a mile and a half. A band saw is run at about half that speed. Planing machine cutters have a speed at the edge of 6,000 feet per minute, as the cutters of molding machinery trims out material at about 4,000 feet per minute. Wood carving drills run 5,000 revolutions per minute. Angers one and one half inch diameter are run 900 revolutions per minute and those half that size are run 1,200 revolutions per minute. Mortising machine cutters make about 300 strokes per minute. Two men operating a cross cut saw, regulate their speed by the eyes of the foreman.

#### Efficiency.

It takes a strong man to be highly efficient. He must abandon prejudices in mind and habits in action; must throw away unbeliefs; learn to think that little which once seemed large, and that vital which was deemed unimportant. Improving a method, getting a machine, hiring an abler man may be done without grasping the first principles of efficiency.

#### Railway Mechanical Convention.

It is reported that 35,000 square feet of space has been already applied for at Atlantic City for the June Convention. The space used last year was 70,772 square feet. Ten per cent. of those who have applied thus far did not exhibit last year. A large number of companies which have never exhibited before have written for detailed information. From present indications it is essential, therefore, that those who expect to exhibit make application at once, and, in any event, not later than February 18, on which date the first assignment of space will be made. Applications should be made to John Conway, 2136 Oliver building, Pittsburgh, Pa.

# Air Brake Department

## Governor Synchronizing System—Brake Valve Manipulation

In last month's issue the operation of the electric air compressor governor was explained, which would suffice for compressor control if but one vehicle is used

type replaces one of the type J previously referred to, but the principles of operation are practically the same, the regulating portion of the type J resembling

parts necessary for the synchronizing system on each motor car are, a master governor, an electro-pneumatic compressor switch, a resistance unit to limit the voltage impressed on the magnet valve portion of the compressor switch, a one point plug connector complete, snap switches for compressor and compressor switch circuits and fuse block and box with fuse for these circuits.

The electro pneumatic compressor switch, controls the current supply to each compressor motor and the master governor acts as a pilot or master switch to open and close the circuits which control the compressor switches.

The compressor switch is operated by compressed air pressure from the main reservoir and a magnet portion, or rather the admission of air to and the exhaust from the air cylinder in which a piston and rod operate the switch to make and break the circuit from the trolley to the compressor motor, is controlled by the magnet valve and in the position shown the compressor switch is making the circuit, and at this time the magnet is



ELECTRO-PNEUMATIC COMPRESSOR SWITCH.

in a train, or if but one motor car and a trailer are in use, but when more than one motor is being operated, especially as with the multiple unit system on 8 and 10 car trains, where each vehicle furnishes its own supply of compressed air as well as its own motive power, the proper control of compressors becomes a problem, which, however, has been solved with the governor synchronizing system. Those who have had some experience with steam driven compressor governors where separate governors were used for two pumps per locomotive, or where one diaphragm portion was used to control two steam portions, will appreciate the difficulties encountered in keeping both compressors in operation after one of the steam portions was in an inferior condition to the other, and especially so when the excess pressure governor top was in use and the same trouble in regulation would be experienced in electric service, that some compressors would furnish all of the compressed air for the system, while others would be operating continuously for the obvious reason that all regulating devices (air operated) could not be adjusted to work in perfect harmony or be expected to remain in perfect harmony for any length of time, therefore the synchronizing system whereby the operations of governors on all motors is made uniform through the use of electric current.

With this system all compressors must start and stop simultaneously and the uniformity of compressor labor is not affected by excessive leakage on any car, incorrect adjustment of governor or feed valve, relative efficiency of the compressors or other causes.

For the system, a governor of the S-6

the action of the steam valve mechanism of the 9½ or 11 inch air pumps, while the form and action of the regulating portion of the type S-6 governor, represents that of two E-6 safety valves, and

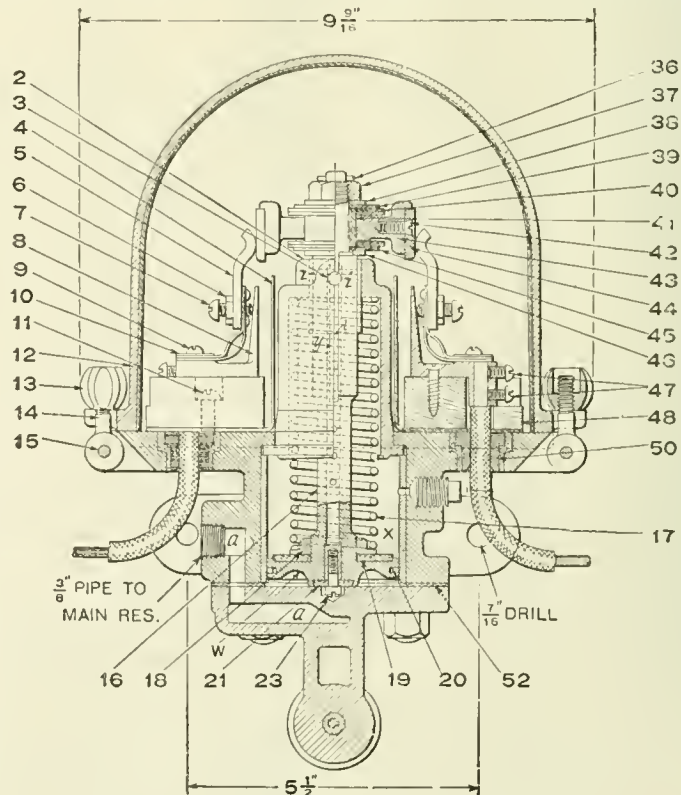

SECTIONAL VIEW OF COMPRESSOR SWITCH.

if the principles of the operation of the type J are understood it will not be necessary to refer to the change in these governors.

For a trolley or third rail circuit, the

energized through current from the master governor. When the desired pressure is attained in the main reservoir the master governor cuts out and de-energizes the magnet and magnetic attraction be-

tween the magnet core 506 and the armature 504 is broken, enabling supply valve spring 516 to unseat supply valve 515 and seat exhaust valve 514. This cuts off communication between the passage b and

core 506 by the magnetic attraction, thereby pushing armature stem 505 inward, unseating the exhaust valve 514 and seating supply valve 515. This action cuts off communication between passages a and b

that the opening or closing of any master governor in the train opens or closes the circuit controlling all the compressor switch magnets.

All the main reservoirs in the train are connected by means of a main reservoir pipe line and the main reservoir on each car is connected to the pneumatic regulating portion of the master governor on that car. When the main reservoir pressure falls below the cutting in point of any one of the master governors, its switch is immediately closed, thereby closing the circuit controlling the compressor switch magnets and causing all the compressors in the train to start simultaneously. Whether one or more of the master governors cuts in at the same time is immaterial, since the compressors will continue to operate and raise the main reservoir pressure on each car and the main reservoir line throughout the train until such time as the governor set for the highest cutting out pressure (which will be the governor that operates to cut in the compressors) acts to open the circuit of the switch compressor switch magnets. This causes the compressor switches to cut out and likewise stop the operation of all compressors simultaneously.

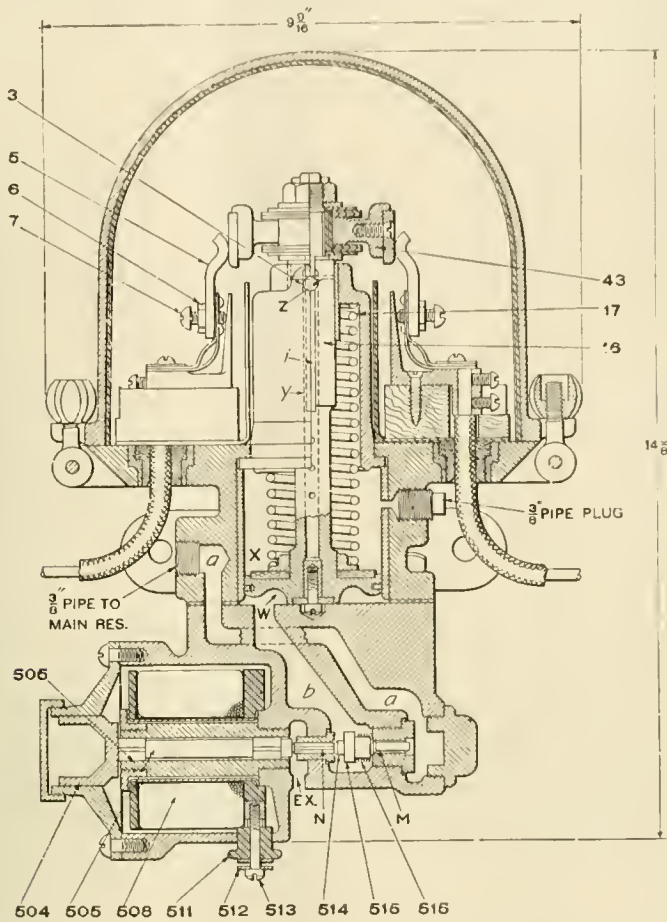

DIAGRAMMATIC VIEW OF COMPRESSOR SWITCH-IN CUT IN POSITION.

the atmosphere and permits main reservoir air to flow from passage a, through passage M to passage b and thence to chamber W, causing the switch piston 16 to move outward and break the circuit

and opens the switch chamber W to the atmosphere through passages b and N and the exhaust opening, allowing the piston spring 17 to force the piston 16 back to cut in position, again completing the cir-

**Brake Valve Manipulation.**

The previous articles on locomotive brake inspection have led up to the subject of brake valve manipulation, or train handling, and this in itself is, from one point of view, too broad a proposition to be handled in printed form; but from another viewpoint it is possible to condense a great deal of the printed matter that relates to train handling, and printed instructions should be confined to, or concerned with, how the brake operates, rather than how the brake should be operated. The modern air-brake instructor makes no special effort to tell

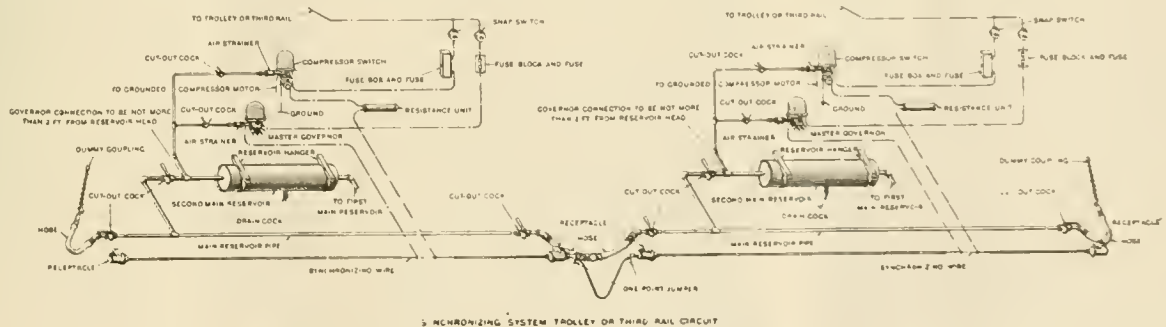

WIRING DIAGRAM OF GOVERNOR SYNCHRONIZING SYSTEM.

from the trolley to the compressor motor. When the main reservoir pressure falls below the cutting in point of the regulation of the master governor, the magnet of the compressor switch is energized and armature 504 is drawn toward magnet

cut from the trolley to the compressor motor. With a trolley or third rail system, the magnets are connected in parallel between the synchronizing wire and the ground, and the wiring is so arranged

an engineer how the brake should be handled, only in a general way, and confines himself to a demonstration of how the brake operates under the various conditions, and leaves the results to the judgment of the engineer.

With this in mind, an effort will be made to sum up the matters that are generally considered as recommended practice, to the intent that a great deal of printed matter may be brought into a concrete form and simplified as far as possible, and beginning at the point where this series of articles dealt with charging a train of cars and maintaining the pressure in the brake pipe, we will assume that a freight train is en route and that no apparent defects of equipment have been discovered.

If the brakes are found to be sticking or dragging, it is permissible to make a quick movement of the automatic brake valve to release position and back to running, provided that some brakes actually have not released, but otherwise this is a very bad practice. To make a practice of this is the surest possible way of having stuck brakes and stalled trains, especially if the habit is indulged in just before ascending grades. Under such conditions the auxiliary reservoirs on the head cars are overcharged, and the brake pipe leakage, if sufficient, will surely cause a brake application.

Another bad practice is the use of lap position of the brake valve just before making a brake application, which affords an opportunity for brake pipe leakage to start the brake application instead of it being started with the reduction from the brake valve; the manner in which this contributes to undesired quick action is very well known, in fact the use of any position of the brake valve may be abused under modern operating conditions.

The secret of smooth train handling is ability to control the slack action, and in a 100-car train there is approximately 50 feet of draw bar and coupling slack, and this slack permits of considerable differences in speed in two portions of the train, and this difference in speed is what causes the shocks to the train during stops made with the brake. The chief consideration in freight train braking on a level track is to stop the train without unnecessary shock or damage, regardless of the distance required to make it. From a viewpoint of smooth handling only the ideal stop with a long freight train would be to close the engine throttle and allow the train to drift to a stop, or the next best would be to close the engine throttle and gently catch up the slack with a light application of the independent brake and allow the engine to stop the train, but this is not considered train braking; so, it follows that while the use of the independent brake for stopping a train is contrary to instructions, and that an eminent authority on air-brake subjects points out that a freight train presents greater possibilities for smooth stops than a passenger train, as there is more coupling slack to absorb the shock, therefore the smoothest possible stop that can be made with a freight train with the auto-

matic brake would appear to be with the lightest possible brake pipe reduction that will run through the train. To decide upon how many pounds reduction this should be is a real air-brake problem, as it varies with almost every different make-up of train, and naturally the more type K triple valves that there are in the train, the lighter the reduction that can be made to apply all of the brakes possible in a long train. As an example, a 5 or 6-pound brake pipe reduction will apply all of the brakes that are in good condition in a 100-car train, if type K triple valves are used on all cars, while if the valves are of the type H, from 12 to 15-pounds brake pipe reduction will be required to apply all of the brakes possible to be applied.

If stopping the train with the lightest initial brake pipe reduction that will apply the brakes at the rear end of the train, which necessarily means that it is to be made far enough away from the desired point of stop for this reduction alone to stop the train, another somewhat heavier reduction should be made within an engine length from the point at which the train will stop, not for the purpose of assisting in making the stop, or rather of shortening the stop distance, but to bring the train to a state of rest, while the brake valve is discharging brake pipe pressure and building up the braking force at the head end of the train. The actual stop will then be made with one application, consisting of two brake pipe reductions, the latter one to have no bearing whatever upon the length of the stop.

If the train is running at a high rate of speed, the initial reduction should be governed by the same process, and it should be followed by a second reduction heavy enough to bring the speed of the train down to about 18 miles per hour, when the brakes should be released and recharged for the stop, and it to be made as outlined, with the lightest possible brake pipe reduction that will run through the train and apply all of the brakes possible.

This has particular reference to the worst conditions encountered, where the train is made up with loaded cars ahead and empty cars at the rear end; however, the most important observation to be made during the initial reduction of the first brake application on a train is to note the direction in which the slack runs, if it runs out or to the rear, it indicates that the greater percentage of retarding force of the brakes is at the rear end of the train, and if the tendency for the slack is to run in and stay in, or bunched, it indicates that the greater braking force is at the head end, but this must not be confused with the general tendency for the slack to run in as a result of the brakes applying first on the head end.

With a mixed train, with the loads

ahead, the tendency is for the slack to run out, and with the empties ahead, for the slack to run in; therefore, a rapid change in slack can be prevented in one case by first bunching the slack with a very light application of the independent brake, and in the other by keeping the slack out or the train stretched by making the brake application before closing the engine throttle. The train of all loads, or all empty cars, is much easier to handle, as the braking force is more evenly distributed and a brake application can be made with the independent valve to bunch the slack before the automatic valve is used, as the tendency will be for the slack to run in on account of the brakes applying first at the head end of the train.

It must be understood that the percentage of braking ratio, or what is sometimes termed "percentage of braking power," may be as much as 60 or 70 per cent. of the light weight of a car, but when the car is loaded, the percentage of braking ratio, by virtue of the added weight of the load, will fall as low as from 17 to 20 per cent. of the total weight of the wheels on the rails; therefore one car may have a percentage of braking force 350 or 400 per cent. greater than that of another car, and an extremely short brake cylinder piston travel may produce 300 or 350 per cent. more braking force on a car than will be developed by an excessively long travel on another car; hence the object of the light initial reduction is to avoid building up enough retarding force in any part of the train to part it. These extreme differences in braking force or braking power is what causes one portion of a train to stop while another portion is moving or in motion. Track conditions with respect to grade and curvature also add to the retarding force of the brake under a variety of conditions; therefore the safest method of handling trains is to use a method that is approved of for the most severe conditions that may be encountered, and naturally they may be modified for handling better make up of trains on perfectly level and straight track.

If this is followed, a stop for water will be made before the engine reaches the plug, so that cutting off the engine will be necessary, and when heading into a siding, it is easier for the brakeman to walk a few feet farther to open the switch than it is for him to drag up enough chain to again get the train together. The fact of the matter is that spot stops should never be attempted with a long freight train, and in backing a train into a siding, the train crew should set enough hand brakes to hold the slack in, and it is good practice to make the application with the engine throttle open and with the independent brake valve in release position.

Releasing the brakes on long trains requires as much care as the application of brake, because release position of the brake valve can be abused, as well as running or service. The time the handle is allowed to remain in release position depends principally upon air pump and main reservoir capacity, length of the train, type of triple valves in use, and the amount of brake pipe reduction that has been made.

As a general proposition, the brake valve should be allowed to remain in release position not over 15 seconds, this time is necessary to force all of the K triple valves possible into retarded release position, the object is to have these triple valves hold in the train slack while the brakes are releasing, and any longer time than this will tend to overcharge the auxiliary reservoirs on the head end to such an extent that a heavy reapplication of the brakes would occur, and this reapplication might result in undesired quick action and wreck the train; as an example, an unusually long time in release position would charge the auxiliary reservoirs, especially with H triple valves, to approximately 90 or 100 pounds, while the rear brakes have scarcely had time enough in which to release; then if the brake valve is brought to running position, the drop in pressure on the cars at the head end of the brake pipe, due to the flow back toward the uncharged cars, is frequently rapid enough to cause a perfectly good triple valve to move into quick-action position, because the drop in the pressure in the brake pipe has been at a faster rate than at which the auxiliary reservoir pressure can flow through the service port into the brake cylinder; or, in other words, the capacity of the service port of the triple valve has been exceeded. Under such conditions, the quick-action would occur only on the head end of the train, and a light service application would result on the rear portion, with the result that there would be a run in from the rear, which might be hard enough to buckle the train. Generally the reapplication of brakes at the head end cannot be avoided and a second quick movement to release position usually effects a release, but the release of the rear brakes requires a driving head or differential in pressure, therefore the usual reapplication after a release.

When moving the brake valve handle from release position back to running, the excess pressure governor top tends to shut down or throttle the compressors, and this in turn tends to still further delay the complete release of brakes, but it is possible to prevent this and at the same time make a more perfect release of brakes by a method that we hesitate to recommend on account of the possibility of a misconception, or of overdoing it; however, if the brake valve is brought from release to running position very

gradually, a position will be found where the flow through the brake valve rotary will be about equal to the capacity of the air compressors, or where the brake valve will deliver the pressure about as fast as the pumps can compress it, and there will be no occasion to use the feed valve until the time that all brakes have about released; but to use a brake valve in this manner with success requires a few experiments and a good general knowledge of air brakes.

Obviously the second man in double heading can assist the head man during a release of brakes by holding his independent brake valve handle on lap position to retain his engine brake and assist in holding in the train slack until such a time as the stop is completed or the type K triple valves have released all the pressure from the brake cylinders.

It should also be understood that it is possible to have a vast difference in pressure between the two ends of a long brake pipe, that is, it is not unusual to have over 100 pounds pressure in the brake pipe on the head cars during a release of brakes and less than 50 pounds in the brake pipe of the rear cars, in fact, it requires almost 30 seconds time for pressure to flow from the main reservoir to the rear car of a 100 car train through an empty brake pipe, therefore under the most favorable conditions it will take from 50 to 60 seconds time from the movement of the brake valve handle to release the brakes on the rear cars in a long train, and 2 or 3 minutes, and possibly more under unfavorable conditions of leakage and moderate sized compressors. For this reason at least  $1\frac{1}{4}$  minutes would elapse from the time the brake valve is moved to release position and the engine throttle opened even under the most favorable conditions, and it is generally recognized that minutes instead of seconds should be considered in releasing brakes on long trains, as an example, if the brake valve was moved to release position and the head brakes released in about 20 seconds time and an effort was made to move the train, the locomotive, if powerful enough would move the head end with the brakes released and leave a portion of the train standing still, which might leave the train in about three sections as the first break would occur near the point at which the brakes were still applied, then quick action occurring at the rear portion of the cars attached to the locomotive would likely result in the second break-in-two.

Attempting to start trains with the rear brakes applied is responsible for about 90 per cent. of the slid flat wheels in freight service, and jerking the cars back and forth trying to start them usually starts an additional amount of brake pipe leakage and still further delays the release of brakes, with the result that no time is gained in the total movement and air

brake men always emphasize the importance of allowing ample time for a release of brakes before attempting to start a train because more wrecks and break-in-two of trains have been caused by a disregard of the time element incident to the release of brakes than from any other single phase of incorrect train handling on level track.

If running at a low rate of speed with the brakes applied it is considered good practice, and it is sometimes necessary to allow the train to stop before an attempt is made to release the brakes, unless there are a large number of K triple valves at the head end, it is absolutely necessary to allow the train to stop.

It is also considered poor practice to release brakes when the rear end of the train is in a curve, if it can be avoided as the curve sets up a considerable amount of retarding effect in addition to that obtained from the use of the brake.

Handling trains in descending heavy grades is essentially different from braking on a level track, as the trains are usually very much shorter and the chief consideration is to hold the train against the possibility of a run-away, and before descending a heavy grade, a standing test of brakes should be made according to the instructions covering the brake operation on that particular division. Standard instructions call for a brake application as soon as the train tips over the summit of the hill, and it should be observed that the brake pipe exhaust corresponds or is of sufficient length for the number of cars in the train and that the brakes are holding. If the first reduction of 7 or 8 pounds materially checks the speed of the train the brakes can be released and recharged, but if a second reduction does not give the satisfactory retarding effect, obviously a call for hand brakes is necessary. Damaging shocks are not so likely to occur in grade braking for a number of reasons, and one of them is that turned up retaining valves and possibly some set hand brakes on the head end tend to keep the slack bunched, also release position of the brake valve is recommended for the time between brake applications, so that a wide open port can be maintained between the main reservoir and the brake pipe, while the excess pressure governor top will maintain the brake pipe pressure at 20 pounds higher than the original figure of feed valve adjustment.

We have stated that this is only an attempt to sum up what is generally regarded as recommended practice, for in order to state exactly how any stop should be made to the best advantage also necessitates an intimate knowledge of every local condition as to grade, curves and location of signals, and with which the experienced railroad man should by every means in his power make himself thoroughly familiar.

# Sweeley Graphite Lubricator

## New Design for Locomotive Cylinders and Valves

A graphite lubricator for locomotive cylinders and valves has recently been patented by Mr. E. H. Sweeley, Richmond Hill, N. Y., which for simplicity of design and ease of control bids fair to mark an important improvement in the methods of applying graphite as a lubricant in locomotive service. As shown in the accompanying illustrations a cup is provided for the lubricating material having an open top which is closed by a screw cap, and lateral lugs formed on the body for attaching it to a suitable support. A tubular extension projects outwardly from the closed bottom of the cup, and a socket is formed on the inside of the bottom of the cup. The extension referred to is threaded at its lower end, and a delivery pipe is connected by a coupling nut. A plug cock controls the communication between the cup and the delivery pipe. The socket of the cup is threaded and a corresponding bushing, centrally bored, is fitted therein. A plunger having a head or piston is fitted loosely in the bore of the bushing, and a conical face which forms a valve is

adapted to seat on a bored face at the top of the bore of the bushing. The plunger is flattened or grooved providing

channels for the passage of the lubricating material around it, through the reduced bore of the outer extension.

The lift of the plunger is controlled by an adjusting stem and is held in place by a lock nut, and a helical spring surrounds the stem. It will be readily noted that the plunger will be raised when the pressure of the steam rushes through the delivery pipe and enters the space around the body of the plunger, the lift of the plunger being regulated by the adjusting stem. Upon the reduction of the pressure by the exhaust the piston of the plunger becomes seated. The alternate movements of the plunger continues during the movements of the piston in the cylinder, the amount of lubricant admitted at each stroke depending on the adjustment of the stem regulating the amount of opening of the plunger. This may be adjusted to any desired amount, one-half ounce to each cylinder per 100 miles has already been found from actual service tests to give best results.

It will thus be seen that the action of



SWEeley LUBRICATOR.

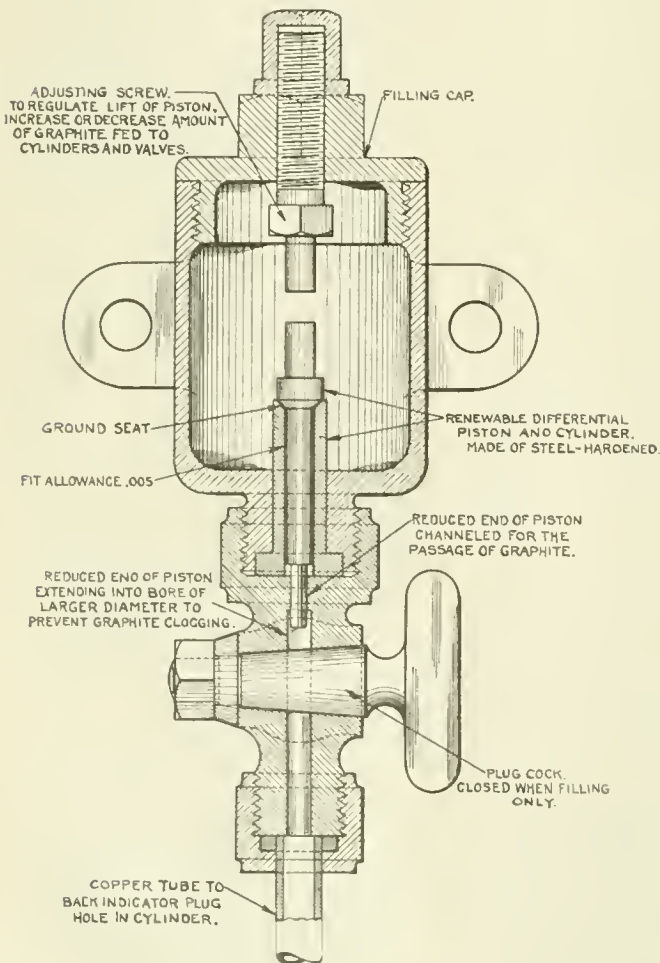

SECTIONAL VIEW OF LUBRICATOR REDUCED TO ABOUT ONE-HALF SIZE.

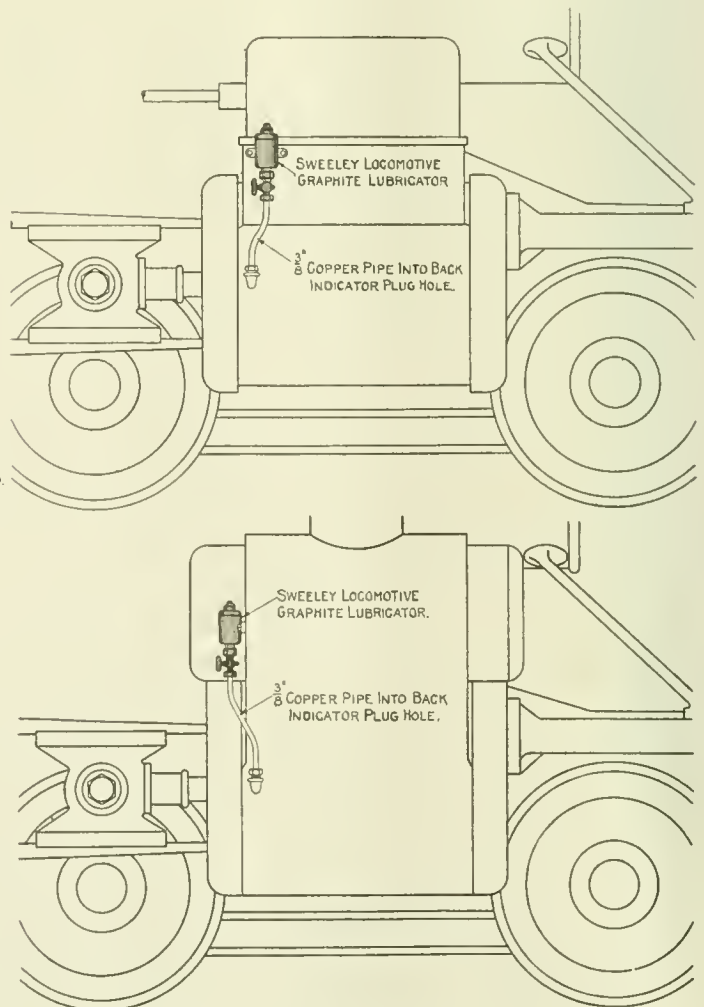

VIEWS SHOWING METHODS OF APPLICATION.

the device in admitting the lubricant is automatic, the supply is easily regulated, and the construction and operation is economical and reliable.

### Freight Cars — Their Construction, Maintenance and Abuse.

From an able paper by C. J. Wymer, general car foreman of the Belt Railway of Chicago, we extract the following: In regard to undesirable features to be avoided, as well as some features which should be favored, the thought naturally arises, how can the problem best be solved? We believe that the remedy lies in standardizing designs and construction as rapidly as consistent, with means of enforcing conformity to same. Standardizing means the elimination of the one man's opinion from which most of our trouble comes and insures through investigation of the subject through the combination of the best talent, preventing certain lines of endeavor being followed to an extreme at the sacrifice of another, by being equalized through resistance offered from another viewpoint and practically assuring a harmonious combination of all desirable features, resulting in the most efficient and economical construction obtainable. Standardizing has several valuable assets, a most valuable one being a reduction in material purchases which now lie dormant for indefinite periods. Material stocks are now much larger than would be necessary except for various designs of more or less equal merit, which, if converted into cash and expended for the purchase of live material and employment of labor for repairing cars would have a far-reaching effect toward better maintenance. It may be argued that standardizing will throttle invention and improvement, but we cannot concur in this thought. We believe it would automatically insure an improvement in construction and would eliminate many ideas of questionable merit. There should be sufficient elasticity to permit the incorporation of improvements of sufficient merit to warrant such action, but alleged improvements which are weighed in the balance and found wanting are not entitled to recognition. The inventive mind would naturally revel in a higher plane of efficiency as "necessity" is said to be "The Mother of Invention."

As to the feature of the M. C. B. rules, making a distinction between owners and delivering line defects, it may be truly said that there is a vast army of men employed by the railroads whose principal duty it is to make records as a means of protection against so-called delivering line defects, and attach greater importance to a few sheathing slightly raked, that may not affect the service of the car, than they do to a worn wheel or numerous other defects, endangering the safety of the equipment, commodity, and human

life. We lay no censure at the doors of the men who are performing this service as we are constantly educating them, that it is almost a crime to overlook a defect involving a defect card which often has a value of less than a dollar. Why not take a business-like view of the situation and cease spending two dollars in an effort to save one. Do away with the delivering line defects, inspect for safety of operation and commodity only, educate these men along the lines of endeavor which have a real value and cease to follow illusions. A vast amount of this labor expense could be diverted to purchasing material and repairing defects which are a menace to safety instead of finding and making a record of a lot of immaterial defects at the expense of more important ones. The reduction in expense would continue down through the offices and result in a larger labor and stationery expense saving a large labor and stationery expense there.

To those who sometimes advance the argument that penalties are necessary against the handling line to promote the proper care of equipment, we would say that in our opinion there is no relation between the thoughts; the employees misusing a car have no knowledge of these penalties and take no notice of the ownership as indicated by the initials on a car. They will damage a car owned by the railroad employing them as readily as they will one owned by a foreign line. They could hardly make this distinction if they desired, on account of the mixed manner of handling cars. Such argument should be discarded.

It is our belief that the railroads are spending more money annually in labor and stationery in protecting themselves against these defects than it would cost to make the repairs, and the repairs are still to be made or allowed to continue in service. There would be less delay to equipment at interchange points. It seems to me it might be in order for this association to appoint a competent committee to make a careful investigation of this subject and find out approximately what we are gaining or losing from these methods. It is not our thought to use the owners' car without justly compensating him for same, but it is our thought that it can be handled more economically by the railroads on a rental basis than through a combination of rental and rules

### Leaving Well Enough Alone

"Leave well enough alone" expresses a sentiment that many railroad men might heed with profit to their employers. The ever tinkering engineer is an expensive employee.

We were very much struck with the truth of that sensible saying when an accident connected with the air brake happened in a small road in the West. The Westinghouse Air Brake Company had

equipped all the passenger cars of this road with air brakes. Nine years after the brakes were applied the superintendent of the road wrote to the brake company saying that some of the brakes were not operating properly.

An inspector was sent to investigate the cause of the trouble, and naturally asked what attention the triple valves and brake cylinders had received.

"Attention," said the superintendent, "they were never touched. I gave orders when the brakes were put on that no one should ever touch any part of these brakes, and my orders are obeyed on this railroad."

"You never cleaned them or oiled them?" asked the inspector.

"Never a clean or an oil," was the reply. "I was afraid that if any of my men took the thing apart that they would never get it together again. You put all the parts in good order again and let us see if they can operate nine years more without attention."

The repairs were made and the brakes went on doing their work for ten years longer.

### Trouble With Water Impurities.

Trouble from corroded and distorted boiler sheets was always experienced on nearly all railroads and so far remedies have been searched in vain. The experience of most motive power people has been that every increase in boiler pressure brought increase of boiler troubles. Most of us realized that increase of boiler pressure brought more bulged and cracked sheets, but no one seemed to know the relation between increase of pressure and increase of sheet trouble.

Through the courtesy of Mr. W. R. Scott, vice-president of the Southern Pacific Company, we have received the following notes compiled by the Universities of California respecting the law of chemistry that applies to pressure and water impurities.

"Whenever there is a tendency to corrosion or chemical action between substances, as between iron or steel plates, and water that may contain ingredients or salts that tend to corrosion of such plates, the rapidity of such chemical action doubles approximately for each ten degrees rise in temperature and pressure.

"There is a difference between different substances, but the above is expressed as a general law."

### Babbitt Metal Casting.

In castings of babbitt metal it is often necessary to core out some part, and a good core has been discovered in the employment of a plastic mixture of salt and glue. A good mixture is made by throwing sufficient salt into the glue to form a stiff paste, which is allowed to harden.

# Electrical Department

## The Curtis Steam Turbine-Generator Details of Progress of the Steam Through the Turbine

The steam turbine has made possible the rapid growth of the electric industry. Practically all of the electric power produced by large steam stations is generated

by turbines. The General Electric Company has brought into prominence the Curtis steam turbine, and its pre-eminence is now so marked that it is taking its

place over all other types in the fundamental requirements of electric power generation. This type of turbine is what is known as an impulse turbine, that is, the rotating element is actuated by the

impact of steam passing through its buckets at relatively high velocity, but without actual expansion in them. The steam is expanded in stationary nozzles, progress of the steam in a Curtis turbine. Entering at A from the steam pipe, it passes into the steam chest B, and then through one or more open valves to the bowls C. The number of valves open depends on the load, and their action is controlled by the governor. From the bowls C, the steam expands through divergent nozzles D entering the first row of revolving buckets of the first stage at E, thence passing through the stationary buckets G, which reverse its direction and redirect it against the second revolving row H.

This constitutes the performance of the steam in the first stage, or pressure chamber. Having entered the first row of buckets at E with relatively high velocity it leaves the last row H with a relatively low velocity, its energy between the limits of inlet D and discharge pressure having been abstracted in passing from C to H. It has, however, a large amount of unexpanded energy since the expansion from C to E has covered only a part of the available pressure range. The expansion process is, therefore, repeated in a second stage.

The steam having left the buckets H, and having had its velocity greatly reduced reaches a second series of bowls J, opening upon a second series of nozzles K. Through these the steam expands again from the first stage pressure to some lower pressure, again acquiring re-

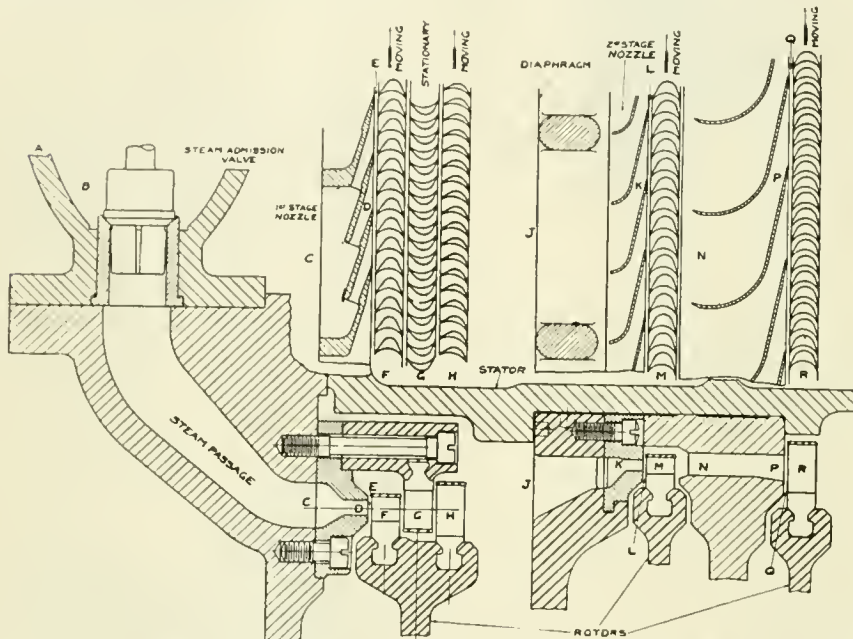
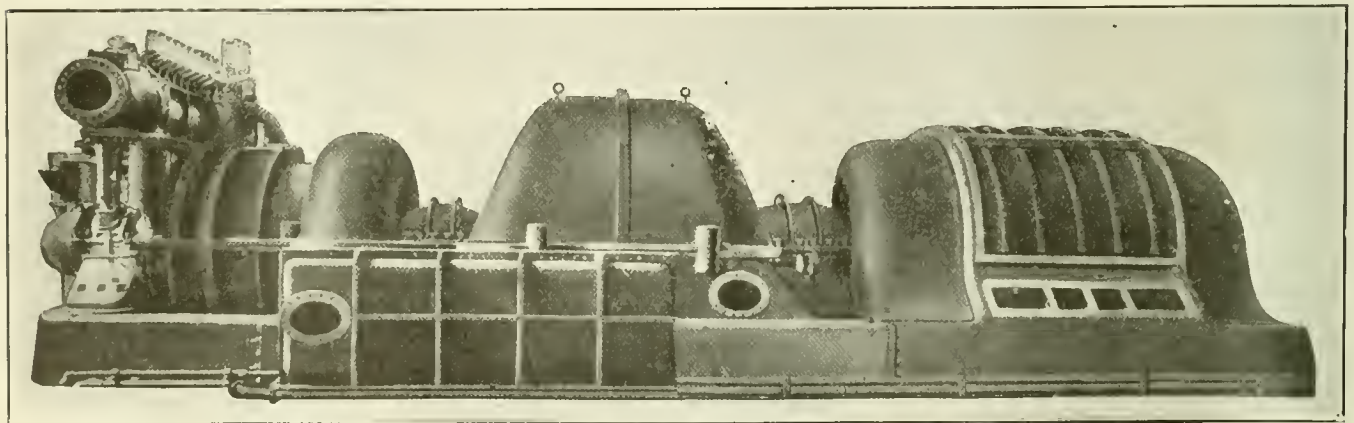

FIG. 1. DIAGRAMMATIC ARRANGEMENT OF MOVING AND STATIONARY MEMBERS OF CURTIS TURBINES.

acquiring relatively high velocity and then passes through and actuates the moving buckets of any stage without further expansion. In the reaction type of tur-

bine there are no distinct nozzles; the steam is expanded in both moving and stationary blades and actuates the former by both impulse and reaction.

Fig. 1 shows diagrammatically the



35,000 KW. CURTIS TURBINE-GENERATOR BUILT BY THE GENERAL ELECTRIC COMPANY.  
WORLD'S LARGEST STEAM TURBINE.

place over all other types in the fundamental requirements of electric power generation. This type of turbine is what is known as an impulse turbine, that is, the rotating element is actuated by the

place over all other types in the fundamental requirements of electric power generation. This type of turbine is what is known as an impulse turbine, that is, the rotating element is actuated by the

place over all other types in the fundamental requirements of electric power generation. This type of turbine is what is known as an impulse turbine, that is, the rotating element is actuated by the

place over all other types in the fundamental requirements of electric power generation. This type of turbine is what is known as an impulse turbine, that is, the rotating element is actuated by the



so on through the remaining stages, if any.

Curtis machines are usually constructed with the first stage wheel carrying two rows of revolving buckets, followed by several stages, each containing a single row. The very small sizes are built with one or more stages, each with two or three rows of revolving buckets.

While all turbine buckets may be subject to wear under the erosive action of very wet steam, or due to corrosion from acids and impurities in the steam, Curtis buckets are adapted to withstand such action. Their very large section permits a certain amount of wear without greatly altering the contour of the steam passages, and consequently without appreciably affecting the economy. On the other hand an equal amount of wear on a bucket of very small section completely changes its shape, with resulting loss in efficiency.

Where turbine blades are required to run with very small radial clearance occasional contact may occur which, while not causing blade stripping, may slightly wear off the blade ends with consequent permanent impairment of efficiency. The end clearances of Curtis buckets is such as to render such wearing impossible.

#### The Telephone System of Dispatching.

As is well known the telephone system of dispatching is rapidly taking the place of the telegraph system. In a number of places it is being used as an adjunct to the Morse system of telegraphy, and at the present time it is being used on more than half of the railroads throughout the country.

As to the advantages of the telephone it is claimed that with the standard equipment designed for train dispatching that the operator is provided with a more rapid means of train movement and that they can handle more business through telephone dispatching. There are fewer possibilities for trouble, and when trouble does occur it rarely puts the entire circuit out of commission. The telegraph sounder is intelligible only to a Morse operator, the bell signal tells every one within hearing that an operator is wanted. Considerable labor is involved in calling an office when the telegraph operator is not within hearing of his sounder, with the telephone circuit no time need be lost, for by snapping a switch, inserting a plug or pressing a button the desired office can be called without loss of time. Thus the regular work of the operator can proceed without interruption.

With the telephone annoyances are sometimes experienced during electrical storms on account of the sharp sounds in the ears, but with the general introduction of the loud speaking receiver instead of the headgear this disadvantage will be eliminated.

If there is ever a time when good train

dispatching is essential it is during a period of wet or foggy weather. Reversing the experience with the telegraph the telephone works even better in bad weather than in good. The lower the static capacity of a telephone line the more satisfactory the service, and damp weather tends to reduce this capacity.

The repetition of orders can be accomplished with accuracy and greater speed and the personal element introduced into the service by the human voice brings the dispatcher nearer his men and better service through team work is the usual result.

From published statistics it would seem that no accidents have occurred through misunderstood orders and none have been attributed to the changed method of dispatching, and that the average efficiency of the telephone is over 22 per cent. greater than the telegraph and that 40 per cent of the time is saved by the telephone.

For some time past there has been considerable discussion in regard to improving the quality of telegraph operators now entering service on some of the larger systems. The introduction of the telephone immediately broadened the supply of men available for its operation for it opened the door for the continuance in service of men who had become incapacitated in service through accident or otherwise. In many instances men of this class whose familiarity with the road, its ruler and train movement had become second nature with them with a little training have developed into excellent telephone operators.

It may be added that the initial cost of the telephone train dispatching equipment is somewhat greater than that of the telegraph system, but its maintenance cost is about the same.

#### Electric Power Development.

Mr. E. M. Herr, president of the Westinghouse Electric & Manufacturing Company, speaking on electric power development, said that the growth in size of electric power stations results not only in economy in their operation but also leads to the development and use of protective and safeguarding apparatus. Many new problems in the control of the enormous amounts of energy distributed have arisen, as well as other problems in the safeguarding and protecting of the generating, regulating and distributing apparatus used. Thus, a short-circuit on a 100,000-kw. power station may bring about conditions so severe as to be beyond the limitations of any known switching or protective apparatus. Such a short-circuit for a moment may correspond to millions of horsepower. Engines and generators may be wrecked, switchboards ruined, disastrous fires started and cables and feeders burnt. In order to prevent

such occurrences, protective apparatus had to be and was developed to more than keep pace with that of power machinery, so that now in a large station very large amounts of money may be expended in protective apparatus, normally inert but which comes into action when danger threatens.

The development and perfection of the modern large power plant increases enormously the advantages in the electrification of railroads.

#### American Museum of Safety Announces Award of Railway Medals.

The American Museum of Safety has just announced through its president, Arthur Williams, that the Anthony N. Brady Memorial medals will be awarded to the Union Traction Company of Anderson, Indiana, for its excellent record in accident prevention during the year 1915. Arthur W. Brady, who is the president of the winning road, is in no way related to the late traction magnate in whose memory the medal was founded. Honorable mention this year goes to the Chicago Elevated Railroads, Britton I. Budd, president, which made the next best record to the Indiana Company. The first award of the Brady Memorial medals was made in 1914 to the Boston Elevated Railroad. Dr. William H. Tolman, secretary of the Jury of Award, the other members of which are Bion J. Arnold, James H. McGraw, George F. Swain, Will J. French and Frank R. Ford, states that the award to the Indiana road was based on accident prevention, not only among its own employes but to the traveling public, on the sanitary conditions of its cars and shops and on the welfare and benefit work it is carrying on among its employes. The principal medal is of gold and is presented to the road. A replica in silver is presented to an operating chief and a replica in bronze to a workman in the shops or on the lines. The winners will receive the medals in person at the annual dinner of the American Museum of Safety at the Waldorf-Astoria, February 3, 1916.

"I'll have to get another typewriter," said the bustling man. "This one is constantly stopping my dictation to ask how some word is spelled."

"That's a great loss of time."

"I don't mind the time, but it interferes with discipline for me to have to keep saying I don't know."

Man's life is like a shadow; it appears to be motionless, but it is ever moving away.

The wise man's tongue is in his heart, and the foolish man's heart is in his mouth.

## Pioneers of Railroads

By ANGUS SINCLAIR, D. E.

The steam engine was developed, first for the pumping of water out of deep mines, then for driving manufacturing machinery. As soon as it worked properly for these purposes, people demanded its application to purposes of transportation. Steam navigation put in the first claim, but steamers had scarcely become familiar to travelers when the claims of land transportation intervened. It came to pass that a few decades after the United States became a nation, many people considered that a very important problem in the world's progress, was the application of power that would send out living cheap transportation into the plains and forests of the world. There was no country in the world, where the opportunities for benefits from convenient transportation were so great as was in America. The country was peopled merely on the seaboard and in the margin of great lakes and rivers. A vast unproductive country was standing waste because there was no means of moving produce. The best thoughts of the time were agitating for the means that would push into the country, over the untrodden prairies, through the vast wildernesses and forests, that could supply any amount of freight, if means were provided to take it away. The idea struck a great many people at the same time, that the nature of the transportation demanded was to be handled by the locomotive engine.

It is generally understood that railway development originated in Great Britain. Moving coal from the mines to the houses of consumers in Britain gave the first work to steam locomotives, and paved the way in 1829 to the construction of the Liverpool and Manchester Railway for general transportation business. Stephenson's "Rocket" on that railway demonstrated the power and speed capabilities of a locomotive, but it is doubtful that railway construction would have been much delayed in the United States had the Liverpool and Manchester Railway never been built.

The Baltimore & Ohio Railroad chartered in 1827 and partly opened in 1830, a line nearly 500 miles long, was under construction when the Liverpool and Manchester was opened. The introduction of railways into the United States indicated how ready the business men of the country were to turn their abilities to mechanical and to engineering pursuits. The construction and equipment of the Baltimore & Ohio Railroad were arduously taken up by the business men of Baltimore and pushed to a successful finish. The railroad was the greatest enterprise the world had contemplated in land transportation.

Some controversy having arisen as to how the Baltimore & Ohio Railroad should be

operated, its line being very crooked and hilly, Peter Cooper a business man of Baltimore constructed at his own expense a small locomotive and set it to work. The locomotive which the designer called the "Tom Thumb" did not exceed 4 horse power, but it demonstrated that the railroad could be operated by locomotives.

Peter Cooper was by no means the first man on the American continent to experiment with what could be done with a steam engine for railroad operating. Robert Stevens, whose name was given to the Stevens Institute of Hoboken, N. J., four years before Stephenson's Rocket was built, constructed a small locomotive and ran it around on a twenty-five foot radius track for the amusement and instruction of his friends. This engine whose boiler had gun barrels for tubes, was put to work not only for the amusement of the friends of the builder, but to act as an object lesson on the possibilities of a high pressure steam engine to do such work. That same Robert Stevens was a constant and persistent advocate of railroad construction. He met with no end of opposition to the efforts he was making. He was one of the most eminent mechanical engineers this country has produced, and performed valuable services that have received meagre recognition. Among the arguments used by Robert Stevens were: "You may talk about steam boats on canals. A canal is stopped half the year by being frozen up. You need to have cars that will not freeze and will go daily from here to Philadelphia and to Washington and all over the country, to develop the commerce and the possibilities of the vast fields and forests, that we now get nothing from but a little grass and wood. You want railroads to develop these great natural resources. Let us be doing and let us not fall behind the world in our efforts."

### Government Ownership of Railroads.

Senator Weeks, of Massachusetts, speaking before the Merchants' and Manufacturers' Association of New York on January 27, said that in the past one of the strongest arguments in favor of government ownership has been that it would prevent discriminations between persons, places and communities; but under our present railroad laws, I do not think that there is enough complaint on this score to warrant taking such action unless the other reasons for so doing are overwhelming. There are other considerations which relate to this subject. The pressure for results in privately owned corporations goads traffic managers to the highest state of activity and efficiency. If they do not get as good results as

their rivals, they are not promoted, and, very frequently, are retired. When we turn to government controlled railroads all this is changed. The taxpayer may be called on when the results are not satisfactory. Therefore there is no particular pressure for results and it is the experience in all affairs of life that you do not get efficiency unless there is some pressure or some personal emolument resulting from it.

### What American Railroads Need.

The *World's Work* for February publishes an article by Otto H. Kahn, of Kuhn, Loeb & Company, New York, on "What American Railroads Need." Mr. Kahn is probably the highest authority on this subject both from the point of view of the public, the investor, and the railroads. Mr. Kahn's article is of far-reaching importance, heralding as it does the new era of co-operation and mutual trust between the public and the railroads. He reviews the history of railroad legislation up to the present time. He points out the strength and weakness of the present situation and suggests the practical remedies which will insure both the public and the railroads a square deal. Coming as it does at a time when this important subject is before the country, Mr. Kahn's article will surely attract widespread attention.

### Troubles in Superheater Lubrication.

The proper distribution of a valve oil, suitable for the temperatures obtained in the superheater, and the correct operation of the engine, will stop the troubles.

Proper distribution will deliver the oil direct to one point in each steam chest, in the centre of the main flow of steam, and direct to each cylinder, at a point in the top of the bore, half-way between the cylinder heads.

Where a suitable oil for lubrication at the temperature obtained is used, the general cause of the troubles mentioned is due to the practice of drifting the engine without steam. This results in the suction of the hot gases, ashes, etc., from the smoke-box into the steam chest and intermediate passages and causes the destruction of the oil and results in increased temperature and the wear of moving parts, due to increased friction.

The use of steam supplied just before or at the instant the main throttle is closed, in a quantity sufficient to prevent the suction of gases from the smoke-box will stop the trouble. Steam for this purpose can be obtained from an auxiliary throttle, used exclusively for this purpose or by "cracking" the main throttle.

The trouble is aggravated by an increase in the oil allowance and by the use of an oil with too low a flash point.

## Washing of Locomotive Boilers Its Importance in Reducing Running Repairs

There is no more important item in locomotive running repairs than in the washing of boilers. Not only does thorough washing repair the faculty of transmitting heat into the water to make steam, but a thorough washing of the boiler prolongs the existence of the boiler and also avoids much repairs that would otherwise be necessary. The work is not pleasant and has been too often performed by incompetent or indifferent labor not properly supervised. In addition to being one of the chief causes of leaking crown and staybolts, it has been repeatedly shown that one-eighth of an inch of scale on heating surfaces results in a loss of about fifteen per cent. of the value of the fuel, so that clean boilers are a great saving in fuel as well as in the cost of repairs.

It is a well known fact that since the adoption of the Federal law in regard to the inspection of boilers a great improvement has been shown, and nothing perhaps has added to this more than the method generally in vogue of washing the boiler with hot water under steam pressure of at least 100 pounds per square inch. It is certain that hot water will more readily remove scale. Steam pressure is not always available, but hot water for the purpose of washing can be economically furnished in any roundhouse when there is a pumping or stationary boiler, and where the roundhouse is heated by steam, a pipe with water attachments may be run parallel with the steam pipes.

In washing the boiler it is not always necessary to remove the dome cap, once in three months now being the regulation, thereby insuring in nearly every class of boiler an opportunity to reach the crown sheet. It is absurd to imagine that any part of the boiler, even if sloped or arched, will take care of itself in the matter of avoiding the tendency to collect scale on the surface of the plates, and especially around the ends of braces or stays, or whatever appliance may be used in holding the sheets together. The liability of the crown sheet to become encrusted is very great, and scale, if allowed to accumulate becomes almost impossible of removal. If taken early in the life of the boiler and regularly and thoroughly cleaned, the scale and sediment can be washed into the legs or hot-tom of the boiler, when it can be readily removed through the plug openings.

It is not necessary to enumerate the number of openings that should be readily attainable in the boiler and serviceable in the washing of the boiler. Their location will readily suggest themselves, and are in general no more than sufficiently numerous to afford an oppor-

tunity of applying the washing apparatus on every part of the boiler, as well as affording the facility of applying chisels to such portions of scale as may be impervious to the action of the water. The application of nozzles of various forms will also readily suggest themselves, and also the necessity for a constant changing of the position of the nozzle so as to reach every point within range.

In inspecting the boiler there are various forms of torches for this purpose. In their absence a temporary form of torch is readily made of asbestos bound with copper wire and soaked in oil. The first inspection will, in all likelihood, reveal portions of scale adhering to the boiler or flues, and in any event a final inspection should be made by the foreman or some competent man detailed by him for that purpose. It is a gross mistake to permit the man who does the washing to inspect his own work. A systematic record of boiler washings should be kept, not only in the hands of the boiler washer but in some convenient receptacle about the locomotive cab. The requirements of locomotive service are often of such a kind as necessitate the removal of locomotives from one part of the railroad to another. It is safe to assume that when the transfer is made the boiler needs washing, but there is usually neither time nor inclination to make any inquiry in regard to the internal condition of the boiler of the borrowed engine. Some weeks of double service adds to the accumulation of foreign matter within the boiler, and by the time that the locomotive is returned to its old quarters a blast of dynamite would be required to loosen the rock-ribbed and ancient deposits that seem as if they were the remains of a prehistoric period.

### Fireproofing Wood.

There are now employed a number of processes whereby wood can be so altered in character that it becomes almost fire-proof, and is no longer liable to dry-rot or any of the disintegrations that come under the head of decay.

Under what is probably the best method, the wood, after having its sap extracted by air-suction in a closed vessel, is charged with a solution of metallic salts, the entire treatment occupying about four hours. It is said that the green wood thus treated neither shrinks nor warps, thus obviating the seasoning generally necessary, and that soft woods become so hardened that they can be utilized for purposes for which they were quite unsuited in their original condition, and become almost incombustible and capable of receiving a high polish.

### Lima Locomotive Corporation.

This company, with plant at Lima, Ohio, has sold its controlling stock to Messrs. Joel S. Coffin and Samuel Allen, who are president and vice-president, respectively, of the Franklin Railway Supply Co., of New York. The plant has a capacity of 800 to 1,000 locomotives per annum, and covers 23 acres of land. The company has been in business since 1872.

### New Car Shops at Knoxville, Tenn.

The advent of steel car equipment gave the mechanical departments of railroads many perplexing problems to solve and compelled the installation of facilities for repairs previously not required. The Southern will provide specially equipped shops at Knoxville, Tenn. The erection begins April 1 and the plant is to be ready for use in six weeks.

### What They Would Take.

A gentleman wishing to discover the predominating trait of mind of the three separate nationalities put the following question to an Englishman, a Scotchman and an Irishman, respectively. He asked: "What will you take to stand all night in the tower of that church?" The Englishman replied: "I should not wish to do it short of a guinea." The Scotchman replied in the good old Scotch fashion of answering a question—namely, by asking another; and he said: "Hoo muckle wud ye be wullin' to gie?" And when the Irishman was asked what he would take he humorously replied, "An' sure, sorr, I think I would be afther takin' a very bad cowl!"

### Soft Conversation.

An incident unexpected happened during the case where the Government is prosecuting certain persons connected with the New Haven Railroad. Mr. Black, a lawyer for the prosecution, was making it hot for some of the witnesses, Mr. Purvis was on the stand and there was an idea that Mr. Black and Mr. Purvis were enemies. One prosecuting lawyer took Black in hand and asked "Do you know Mr. Purvis?" "Do you know Mr. Purvis?" was the first question. "Yes," was the reply. "Have you met him lately?" "Yes, I met him in the United States Hotel yesterday." "Did you have any conversation?" "Yes." "What did Mr. Purvis say?" He said, "Let us go and have a drink."

### Cause and Effect.

A wise man was asked why did his friend die; he replied, "Because he existed."

# Items of Personal Interest

Mr. J. G. Ayers has been appointed master blacksmith of the Southern Pacific shops at Tucson, Ariz.

Mr. P. Carlisle has been appointed roundhouse foreman of the Intercolonial, with office at Moncton, N. B.

Mr. A. S. Brown has been appointed storekeeper of the Salt Lake & Ogden, with office at Salt Lake City, Utah.

Mr. R. E. Kelly has been appointed master mechanic of the Kansas City & Memphis, with office at Rogers, Ark.

Mr. G. Canfield has been appointed locomotive foreman of the Canadian Northern with office at Jellicoe, Ont.

Mr. J. M. Parker has been appointed general manager of the Arkansas & Louisiana Midland, headquarters at Crossett, Ark.

Mr. Walter Shelton has been appointed road foreman of engines on the Chesapeake & Ohio, with office at Silver Grove, Ky.

Mr. Maynard D. Church has been appointed chief engineer of the Terry Steam Turbine Company, with offices at Hartford, Conn.

Mr. I. C. Newmarch has been appointed superintendent of shops for the New York Central Lines with office at Collinwood, Ohio.

Mr. E. F. McCafferty has been appointed roundhouse foreman of the Cincinnati, Hamilton & Dayton, with office at Toledo, Ohio.

Mr. W. J. Murrian has been appointed general foreman of the Southern railway, with office at Salem, N. C., succeeding Mr. T. S. Inge, deceased.

Mr. I. H. Drake has been appointed master mechanic of the Atchison, Topeka & Santa Fe with office at Cloves, N. M., succeeding Mr. Hugh Schaefer.

Mr. A. Grey, formerly assistant car foreman of the Canadian Northern at Winnipeg, Man., has been appointed car foreman on the same road with office at Lucerne, B. C.

Mr. G. H. Nowell, formerly locomotive foreman of the Canadian Pacific at Cranbrook, B. C., has been appointed district master mechanic on the same road, with office at Nelson, B. C.

Mr. H. C. May, formerly superintendent of motive power of the Chicago, Indianapolis & Louisville, has been appointed to a similar position on the Lehigh Valley, with office at South Bethlehem, Pa.

Mr. W. L. Dunkerley has been appointed master mechanic of the Yellowstone division of the Northern Pacific, with office at Glendive, Mont., succeeding Mr. E. D. Johnson, transferred.

Mr. John D. Kendrick, formerly master mechanic of the Buffalo, Rochester & Pittsburgh at Puncatawney, Pa., has been appointed to a similar position on

the same road, with office at Du Bois, Pa.

Mr. Paul A. Platz has been appointed manager of the advertising department of the Cleveland, Cincinnati, Chicago & St. Louis, and Cincinnati Northern railroads, with office at Cincinnati, Ohio.

Mr. L. B. Larsen, formerly locomotive foreman of the Chicago & Alton at Kansas City, Mo., has been appointed erecting shop foreman in the shops of the Oregon Short Line at Poocatello, Idaho.

Mr. J. B. Halliday has been appointed acting master mechanic of the Central and Western divisions of the Minneapolis & St. Louis, with office at Minneapolis, Minn., succeeding Mr. Wm. Gemlo, resigned.

Mr. H. F. Staley, formerly master me-



BARON SHAUGHNESSY,  
President of the Canadian-Pacific.

chanic of the Boyne City, Gaylard & Alpena, has been appointed superintendent of motive power and machinery on the same road, with office at Boyne City, Mich.

Mr. J. H. Hanna, formerly assistant road foreman of engines on the Pennsylvania Lines west of Pittsburgh, western division, has been appointed road foreman of engines, succeeding Mr. C. R. Colmey, deceased.

Mr. James D. Searle, formerly erecting foreman at the Du Bois shops of the Buffalo, Rochester & Pittsburgh, has been appointed master mechanic of the middle and Pittsburgh division, with office at Puncatawney, Pa.

Mr. G. I. Duffey, formerly master mechanic of the Lake Erie & Western, at Lima, Ohio, has been appointed superintendent of motive power on the same road, with office at Lima, and the position of master mechanic has been abolished.

Mr. O. E. Maxwell, formerly assistant

road foreman of engines on the Pennsylvania Lines west of Pittsburgh, western division, succeeds Mr. J. H. Hanna, promoted, and Mr. S. E. Wilmore, succeeds to the position vacated by Mr. Maxwell.

Mr. John Wintersteen has been appointed general master mechanic of the Lehigh Valley, with offices at South Bethlehem, Pa. Mr. Wintersteen was formerly in the service of the Philadelphia and Reading, Norfolk & Western, and has a wide experience in railroad work.

Mr. G. Moth, formerly district master mechanic on the Canadian Pacific at Revelstoke, B. C., has been appointed district master mechanic on the same road, with office at Cranbrook, B. C., and Mr. L. Fisher has been appointed master mechanic at Revelstoke, succeeding Mr. Moth.

Mr. E. T. Lamb was made president of the Atlanta, Birmingham & Atlantic Railway on January 1. Mr. Lamb was receiver and general manager of the Atlanta, Birmingham & Atlantic Railroad Company, the receivership of the property having been dissolved and the new name adopted.

Mr. F. F. Gaines, superintendent of motive power of the Central of Georgia at Savannah, Ga., has been granted leave of absence on account of ill health, and Mr. W. H. Fetner, master mechanic at Macon, Ga., has been temporarily appointed to fill the position during the absence of Mr. Gaines.

Mr. C. F. Burgman, formerly master mechanic of the Chicago, Indianapolis & Louisville & Bloomington, Ind., has been appointed superintendent of motive power on the same road, with office at Lafayette, Ind., succeeding Mr. H. C. May. Among other promotions that of Mr. John Neary, formerly general foreman of the car department at Lafayette, Ind., has been appointed general car foreman, and Mr. W. H. Strang, formerly road foreman of engines at Lafayette, has been appointed general road foreman of engines, with office at Lafayette.

Sir Thomas Shaughnessy, who, in addition to his other honors, has now become a Baron of the British Empire, has been connected with the Canadian Pacific Railway since 1881, when he was appointed purchasing agent of the company. In 1891 he was appointed vice-president, and in 1899 he succeeded Sir William Van Horne as president. He was born in Milwaukee, Wis., in 1853. Of all the New Year's honors and titles awarded by the British government none resulted from higher merit, and none are being received with greater approval by the people of the Dominion of Canada.

## Obituary.

JOHN ALEXANDER HILL.

John Alexander Hill, president of the Hill Publishing Company, New York, died suddenly while on his way to business on January 24. Mr. Hill was the first editor of the *LOCOMOTIVE ENGINEER*, the first name of *RAILWAY AND LOCOMOTIVE ENGINEERING*, and many of our present readers will remember the amusing sketches which Mr. Hill used to write called "Jim Skecner's Object Lessons."

John A. Hill was born in Vermont, but removed when a boy with his parents to Wisconsin where he was raised and educated. At fourteen he entered a printing office, but had to leave that business owing to impaired health. At that time there was great mining excitement in Colorado and John went there seeking for fortune in silver mining, but soon switched off to railroad work, having secured a job as fireman on the Denver & Rio Grande Railroad. There he rose to be a locomotive engineer, but finally left railroad-ing to become editor of the *LOCOMOTIVE ENGINEER*, which the American Machinist Company began to publish January, 1888. In October 1891 Mr. Hill and Angus Sinclair combined interests, forming the Sinclair & Hill Company, which purchased the *LOCOMOTIVE ENGINEER*, expanded the publication and called it *LOCOMOTIVE ENGINEERING*. A few years later Sinclair & Hill purchased the *American Machinist*, but kept it only a few years when they divided their interests, Hill taking the *American Machinist* and Sinclair *LOCOMOTIVE ENGINEERING*. Mr. Hill established the Hill Publishing Company which controls the *American Machinist*; *Power*; *Coal Age*; *Engineering News* and other mechanical journals.

In 1882 he married Miss Emma B. Carlisle who with one daughter survives him.

The numerous friends of Mr. Hill are astonished that at his age he has passed away so suddenly, for he was a strong, robust man of exceptionally good habits. Judging from his apparent physical condition we should have expected that John A. Hill would have comfortably reached four score years.

A. C. LAMONTE.

Mr. A. C. Lamonte, general manager of the coal mining department of the Delaware, Lackawanna & Western, died at his home in Scranton, Pa., last month. In 1888 he entered the service of the Central railroad of New Jersey, and in 1889 he was appointed engineer in the coal mining department of the Lackawanna, and was promoted to district engineer, assistant chief engineer, chief engineer, and a short time ago was appointed general manager of the coal mining department. He was in his forty-seventh year.

OLIVER C. GAYLEY.

The death is announced of Oliver C. Gayley, vice-president of the Pressed Steel Car Company. He was born in Maryland and was a graduate of the Franklin Institute, Philadelphia. He entered railroad service on the Pennsylvania in the engineering corps; and won rapid promotion to the position of supervising engineer. He served several years later as division engineer of the Philadelphia & Reading. He was for some time associated with the St. Louis Car Wheel Company, and also acted as general manager of sales Safety Car Lighting & Heating



OLIVER C. GAYLEY.

Company. Latterly he was appointed general manager of sales of the Pressed Steel Car Company, and after serving some time as second vice-president he was elected first vice-president. He was in his fifty-sixth year.

## Safety-First Exhibit, Washington, D.C.

There will be held in Washington during the week of February 21-26 inclusive, a "safety-first" exhibit in which all of the Government Departments are taking an active part. This exhibit will take on a national aspect, as manufacturers and operators from all over the country are invited to be present, in order that they may see what the Government of the United States is doing in "safety-first" work.

Secretary of the Interior Lane has sent a letter to the governor of each State inviting him to send a delegate, and asking that the Chief Mine Inspector, a representative of the industrial commission, or of other agencies engaged in compiling statistics relating to the various mineral industries, also attend this exhibition.

It is hoped that all interested persons will visit the "safety-first" exhibit, and will attend the conference of State mine inspectors, which will be held at the office of the Bureau of Mines on February 24, 1916.

JOHN ALEXANDER HILL.

The briefs filed by the States discuss at some length the question of value, and its measure in rate cases, and contend that the Valuation Act does not require, and that the Commission should not, in the pending valuation proceedings, ascertain the value of the property of the carriers, but should ascertain and report only the cost data and other details specified in the Valuation Act.

The carriers are of the opinion that the completion of the inventory, and the ascertainment of all the data required by the Act, should precede the discussion of the principles on which the value is to be determined. The carriers do not at the present time discuss value, although stating their dissent from certain views expressed in the briefs of the States.

The carriers will be glad to file a brief on the principles of value, its determination, and discuss the same at any time by oral argument before the Commission, if such be the desire of the Commission. The carriers think that such discussion should be had.

## Erie Railroad.

Work will be started in the near future, it is said, on two pieces of double tracking on the New Castle branch, six miles between Sharon and Middlesex and four miles between New Castle and water works.

One of the things that has made it possible for the Erie Railroad to meet without embarrassment the demand made upon it by the wonderful increase in east-bound traffic, is the lowering of grades, which formerly required shorter trains, slower movement and greater expense. Between Jersey City and Salamanca, N. Y., a distance of 414 miles, the ruling grade has been brought down from 0.65 to 0.2 per cent. The present ruling grade is said to be lower than that of any other railroad running from Pittsburgh, Buffalo, or the Ohio State line to New York city. Between Marion, Ohio, and Hammond, Ind., the ruling grade of the Chicago & Erie has been reduced from 0.55 per cent. westbound and 0.5 per cent. eastbound to 0.2 per cent. in each direction, with the exception of one short 0.5 per cent. grade, which is to be lowered to that figure, when the whole stretch will be uniform. The Chicago & Erie is now 95 per cent. tangent, and has the alignment and lowest grade of any road of its length. Since 1901 the Erie has spent \$100,000,000 (exclusive of maintenance and renewal in kind) for additions and betterments. This included: Grade reduction and additional running tracks, \$32,757,995; equipment, \$49,829,719; and the rest for automatic block signals, grade-crossing eliminations, terminals, shops, yards, bridges, etc. Nearly \$14,000,000 of this was paid out of income.

# Railway Management in South Africa

## Mr. Dooley Gives His Views on the Officials

"Wan av thim ing'naers came through the lighth on his coach this afternoon," said Finnigan.

"Ing'naer," says Mr. Dooley, with a tinge of scorn in his voice; "whar've ye been lately at all, at all, Finnigan? Superintindhint, ye manc."

"What's the diff'rance, Dooley?" asks Finnigan, evincing a keen desire for information.

"Well, I don't exactly know mesilf," replies Dooley, "but there's a diff'rance anyway. Iver since the thransp'tation systhlim was intrajuced there've been no ing'neers, except on consthruktion. They'se superintindhints, assistant superintindhints, deputy assistint dittoes, acting deputy assistint dittoes, and divvel knows what else, but annyhow all superintindhints."

"I wonder how the head off'ce keeps thrack av the whole bilin' of thim," says Mr. Finnigan, meditatively.

"Guess that's what they arre paid for," says Mr. Dooley. "Just as you an' me knows a heel bolt from a slaper, so a good staaff clar-rk knows a superintindhint from an assistint wan of the same soort, just by lookin' at him. Comes water'l or p'raps 'tis thraining. I hear-r some av thim staaff clar-rks do get big pay."

"But what's this thransp'tation systhlim mane, anyway," asks Mr. Finnigan, determined that the point at issue shall not escape attention.

"I'm not quite shure whither I've the hang av it mesilf," replies Mr. Dooley, "but f'rm what I hear-r f'rm some av the clar-rks that come along with the superintindhints, 'tis a soort of poolin' av the brains av the railway in th' intherists of ayconomy an' eefishincy."

"Just loike Mrs. Dooley makes Oirish stew all in the wan pan to save pans," suggests Mr. Finnigan.

"Something loike that, bedad," acquiesces Mr. Dooley, "the consequince bein' that the carrots taste of cabbage and the turnips taste av onions, instid av ache havin' the partic'lar flavour that God give ut."

"As I figger it out," goes on Mr. Dooley, "all the men ar-re on the same footin', whither ing'naers, drivers, porters, fitters, or clar-rks, an' 'ave to take a giniril intherist in the consarns of the administhration. F'rinstins, if wan av thim elicticity fixins undther a thrain breaks down an' the sanit'ry porther happens to be the highest man ther're 'tis his jooty to fix it up."

"But supposin' he knows nothin' about ut?" asks Mr. Finnigan.

"He's got to do his best undher the circumstances," says Mr. Dooley. "an' look for promotion. Th'other day I did hear-r

as how a sanit'ry porther got foolin' with a spanner on wan av thim same fixins. It kicked back turrible haar-rd, an' now he's in hospit'l with an official inquiry waitin' f'r him to come out."

"Do they iver have anny av us in the off'ces?" asks Mr. Finnigan, eagerly. "I shud verry much loike to see what them fellers in cuffs and collars do all day."

"I don't think the systhlim's dayveloped enough yit f'r that," says Mr. Dooley. "'Tis all th'other way about. 'Tis the cliver young sphalpeens f'r'm the off'ces that have to tache us an' not us thim. But sometoimes they'se too cliver. I've har-rd say that a little larnin' is dangerous, an' 'tis mesilf that's thinkin' 'tis thru. A young feller in cuffs an' gaiters came along th'other day. I think he's a shor-rt-hand writer in the rates off'ce or something loike that. Says he, 'Dooley, I'll have to report ye.' 'An' what f'r?' says I. 'Bekase yer road isn't in good ordher,' says he; 'yer rail jints arren't close up, an' the slapers arren't evenly sprid out.' I says nothin', but I'm thinkin' that if iver that raypoort gits to headquarters there'll be throubble, an' it won't be at this ind av the sthick."

"'Tis as funny," says Mr. Finnigan, "as that sthory in the magazine about the man that sint dinner plates f'r fishplates."

"No sthory at all, Finnigan," says Mr. Dooley, "but a fact as happened to mesilf." "Yer coddin'," says Mr. Finnigan, sceptically.

"Divvle a cod," retorts Mr. Dooley, with some asperity. "I wance goth th' inspicthor to woire f'r some fishplates f'r my lighth. Well, wan day there comes along a big craate. When I opened it I found it full av paper an' shavins, an' when I pulled out all thim I found a lot av dinner dishes, too deep f'r plates an' not deep enough f'r basins. Th' inspicthor towld me they'se soup plates, an' said that superintindhints drink their soup out av plates an' not out av basins."

"Is that so?" says Mr. Finnigan, in wonderment.

"So I'm towld," says Mr. Dooley. "Well, th' inspicthor wrote about the soup plates and he read me the letter that came back. As far-r as I can remember ut said that the giniril manager's instruhtions was that nothing was to be bought whoile there was annything suitable in sthock. Av coorse, th' inspicthor sint thim back, and he towld me afterwards that the plates had been sint by a young man who had just been thransferred from the cathering depar-tment."

"That young man should 've got a prize in the suggistions schame," remarks Mr. Finnigan.

"Loikely enough," replies Mr. Dooley.

"'Tis a gr-rate schame is that same suggistions schame. It reminds me av a privit school where ivery man gits a prize to encourage the others. Now then, walk up f'r yer broight new half-crowns!"

"But shurely," expostulates Mr. Finnigan, "it encourages intherist in the sarv'ce?"

"Intherist in the sarv'ce, is ut ye say, Finnigin? A lot av the staaf treats their wages as what the lawyers call a retainin' fee, an' spind their leisure minutes woorrkin' out invintions to git a half-crown f'r'm the suggistions committee. That the show'ls should be stacked nately alongside the loine whin the day's work is done—half-a-crown. That platforms should be washed only whin there's no passingers about—half-a-crown! That ingin drivers an' firemen should be pr'vided with soap an' towels to kape their faces clane so as not to frighten the lady passingers—half-a-crown! That a map av the sate av the war-r should be hung up in waitin' rooms that passingers may not notice how late the thraains ar-re—tin bob!"

Mr. Dooley, with rising emphasis, is going on to give other imaginary instances of the operation of the Suggestions Scheme when Mrs. Dooley, coming out of the cottage wiping her red face with her apron, hammers three times with a broken fishplate on a suspended length of rail. This is the signal that the evening meal is ready. Both men rise and knock the remains of the tobacco out of their pipes.

"I've heard av only wan real good suggistion f'r which a prize was given," says Mr. Dooley as they walk towards the cottage.

"An' what was that?" inquires Mr. Finnigan, with interest.

"Well, I don't know whither 'tis thru," says Mr. Dooley, "bnt I was towld ut by a young gentleman from the head off'ce. A stationmaster suggisted himsilf f'r an increase av pay. Whither it was that the thrassic was better at his station, or whither it sthrukt the Staaff Committee just afther a good male, divvle if I know. But he got it."

"Gee whiz," ejaculates Mr. Finnigan with surprise.

"But that's not all," goes on Mr. Dooley. "The same stationmaster—who they do tell me will make his mar-rk in the sarv'ce—thin wrote to the Committee an' asked f'r a rewar-rd bekase his suggistion had been carried out. An' he got half-a-crown."

The statement is too much for Mr. Finnigan, who remains silent as the two men enter the cottage.—*South African Railways and Harbors Magazine.*

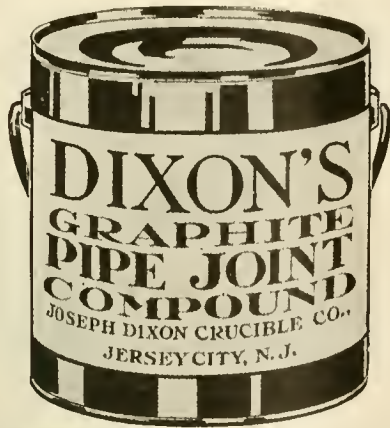

## DIXON'S GRAPHITE Pipe Joint Compound

Here's a graphite product that will show economy of labor and material all through a railway system. Use it wherever there's a threaded or a flanged joint and note the difference. The graphite is a lubricant making light the labor of screwing up and unscrewing. It protects against rust and corrosion, and never hardens or sets. Send for a sample and convince yourself. Ask also for "Valuable Graphite Products," No. 69-D.

Made in Jersey City, N. J., by the  
**Joseph Dixon Crucible Company**

Established 1827

D-21

### Railroad Equipment Notes.

The Wabash has ordered six postal cars from the American Car & Foundry Company.

French Government is reported as ordering 4,000 steel cars from the National Steel Car Co.

The Pittsburgh & Lake Erie has ordered 6,000 tons of rails from the United States Steel Corporation.

The Virginian Railway has ordered one triple articulated locomotive from the Baldwin Locomotive Works.

The Chicago, Milwaukee & St. Paul has ordered 30,000 tons of rails from the United States Steel Corporation.

The Canadian Government Railways have ordered 200 30-ton wooden box cars from the Canadian Car & Foundry Company.

The Southern Railway has ordered 300 tons of steel from the Virginia Bridge & Iron Company for a repair shop at Knoxville, Tenn.

The United States Steel Products Company has received an order for 4,000 tons of rails for India and 2,000 tons for Portuguese East Africa.

The Erie has ordered 10 Santa Fe type locomotives from the Baldwin Locomotive Works and 10 of the same type from the American Locomotive Company.

The Pennsylvania Railroad has ordered 3,000 hopper gondola cars from the Cambria Steel Company and 2,000 of the same type from the Ralston Steel Car Company.

The Lehigh Valley, recently reported as being in the market for 15 switching locomotives, has ordered these locomotives from the Baldwin Locomotive Works.

The Cincinnati, Indianapolis & Western has ordered 3 coaches, one dining car, 3 passenger and baggage cars and 2 postal cars from the American Car & Foundry Company.

The Pennsylvania Railroad has ordered from the Western Electric Company telephone equipment for train despatching lines on five sections of the road, aggregating 577 miles of line.

Grand Trunk Railway is repairing its machine shop on Sebastopol street, Montreal, Que., which was recently destroyed by fire. The new building is to be of steel and brick construction.

New York Central has placed an order with the American Locomotive Co. for 5 Mallet (0-8-8-0) type locomotives. The cylinders will be 26 and 40 by 28 inches, driving wheels 51 inches and total weight in working order 466,000 pounds.

The Newburgh & South Shore has ordered 2 Mogul locomotives from the Baldwin Locomotive Works. These locomotives will have a weight on the driving wheels of 168,000 pounds and will be equipped with superheaters and brick arches.

Contract for the reconstruction of the car shops of the Atchison Topeka & Santa Fe, at Argentine, Kan., destroyed by fire last year, has been let to the Central Concrete Construction Company, of Kansas City, Mo. The contract amounts to about \$40,000.

The Canadian Government Railways have ordered 15 Consolidation and 10 Pacific type locomotives from the Canadian Locomotive Company, Ltd. The Consolidation locomotives will have 24 by 32-in. cylinders, and a total weight in working order of 232,000 pounds. The Pacific type engines will have 23½ by 28 in. cylinders, and a weight in working order of 230,000 pounds.

Indiana Harbor Belt Railroad has ordered 20 Mikado (2-8-2) locomotives with cylinders 25 by 32 inches, driving wheels 63 inches and total weight in working order 294,000 pounds and 10 eight-wheel (0-8-0) locomotives with cylinders 25 by 30 inches, driving wheels 58 inches and total weight in working order 240,000 pounds. The order was placed with the American Locomotive Company.

Delaware, Lackawanna & Western has ordered 7 Pacific (4-6-2) and 10 Mikado (2-8-2) locomotives from the American Locomotive Company. The Pacific type engines will have cylinders 25 by 28 inches, driving wheels 70 inches and total weight in working order 291,000 pounds. The cylinders of the Mikado engines will be 28 by 30 inches, driving wheels 64 inches and total weight in working order 323,000 pounds.

The Lehigh & New England recently reported as being in the market for 550 hopper and 200 flat cars, has ordered 550 50-ton steel hopper cars and 200 50-ton composite drop-end gondola cars from the Pressed Steel Car Company. These cars will be equipped with the Carmer uncoupling device, Buffalo brake beams, Westinghouse air brakes, Farlow twin-spring draft gear, Gould bolsters and Gould journal boxes. Simplex couplers will be used on the gondola cars and Sharon couplers on the hopper cars.

## Books, Bulletins, Catalogues, Etc.

### Proceedings of the Twenty-third Annual Convention of the Traveling Engineers' Association.

The proceedings of the annual convention of the Traveling Engineers have been carefully compiled by the secretary, Mr. William O. Thompson, Buffalo, N. Y., and are now published in a handsome volume of 400 pages with numerous illustrations and photographs, and is a valuable addition to the volumes already published by the association. Of the subjects treated, perhaps the most important is that in regard to "The Effect of Properly Designed Valve Gear on Locomotive Fuel Economy and Operation." This subject occupies 60 pages of the volume, and it is not too much to say that it is perhaps the most exhaustive treatment that this important subject has ever had, coming as it does from a body of men who are all full of interesting experiences and shows a thoroughness that can only come to those who have completely mastered the subject.

"The Difficulties Accompanying Prevention of Dense Smoke and its Relation to Cost of Fuel and Locomotive Repairs," is also an important contribution occupying over 50 pages of the work. Among the other more important subjects treated of is that of "Recommended Practices for the Employment and Training of New Men for Firemen," and "How Can the Road Foreman of Engines Improve the Handling of the Air Brakes on Our Modern Trains?"

The discussions which the presentation of the papers submitted brought out are presented in full in the volume and we cannot do better than recommend a careful perusal of the volume to all who are interested in the subjects treated of in the volume. Copies may be had from the secretary of the association. Price \$1.50.

### The Mechanical Engineers' Pocket-Book.

John Wiley & Sons have just published the ninth edition of the Mechanical Engineers' Pocket-Book, by William Kent, M. E., which now more than completes one hundred thousand copies of this excellent work. It need hardly be said that since the publication of the last edition five years ago, there have been many notable advances in many branches of engineering, and many engineering standards have been changed, involving many changes in the older editions, besides the addition of 150 pages of new matter. The chapter on machine shop practice has been entirely re-written and doubled in size. The subject of electrical engineering has also been entirely re-written and brought into agreement with present practice. The chief merit of the book lies in the fact that all of the valuable data has

been compiled from actual experiences. Although the book extends to more than 1,500 pages with illustrations, where they are necessary, the fine quality of the paper and the flexible binding forms a compact volume not too bulky to be conveniently carried in the pocket. The book has been the standard work of its kind for over ten years, and has earned a distinctive place for itself in the mechanical engineering literature of our time.

### Bridge Foundations.

Messrs. Scott, Greenwood & Sons, 8 Broadway, Ludgate E. C., London, England, has issued No. 19, in the Broadway series of engineering handbooks, an excellent work on Bridge Foundations, by Wm. Burnside, C. E. It extends to 148 pages, with 31 diagrams, bound in cloth. Price \$1.50. The book is intended only as an introduction to the subject of bridge foundations, and has been written from actual experiences under such eminent authorities as the late Sir William Arrol, LL. D., Mr. A. S. Biggart, C. E., and others. Much material has also been gathered from eminent American authorities. The foundation is defined as that part of the substructure which is underground or under water, as the case may be, low water level being taken in the case of tidal waters, and ordinary water level in other cases. In other words, the foundation is the part that is hidden and out of sight. The work is complete in its kind, presenting the details of the various types of foundations of bridges, and is a valuable addition to the excellent series of engineering books published by the firm. Van Nostrand & Co., 25 Park Place, New York, are the American agents.

### Accident Bulletin.

The Interstate Commerce Commission has issued Bulletin No. 56, showing collisions, derailments, and other accidents resulting in injury to persons, equipment, or roadbed, arising from the operation of railways used in interstate commerce, during April, May and June, 1915. It will be noted that although every report in regard to accidents must be furnished under oath in less than one month after the event, it takes the government officials six months to furnish the bald statement of figures, which might be finished in six days by a few competent clerks. It is said that bad news flies fast, but whether the news be good or bad the government office holder takes his time: In the present instance the news is good so far as the decrease in the casualties among the railway employees is concerned. This is undoubtedly owing to the earnestness with which the "Safety First" movement has

# GOLD Car Heating & Lighting Company

Manufacturers of

ELECTRIC,  
STEAM AND  
HOT WATER  
HEATING  
APPARATUS  
FOR RAILWAY CARS  
VENTILATORS  
FOR PASSENGER  
AND REFRIGER-  
ATOR CARS  
ACETYLENE SYSTEM  
OF CAR LIGHTING

Send for circular of our combination PRESSURE AND VAPOR SYSTEM OF CAR HEATING, which system automatically maintains about the same temperature in the car regardless of the outside weather conditions.

Main Office, Whitehall Building  
17 BATTERY PLACE  
NEW YORK



# Hydraulic

**Riveters Fixed and Portable  
Punches, Shears,  
Presses, Lifts, Cranes  
and Accumulators.**

**Matthews' Fire Hydrants,  
Eddy Valves  
Valve Indicator Posts.**

**The Camden High-Pressure Valves.**

## Cast Iron Pipe

**R. D. Wood & Company**

**Engineers, Iron  
Founders, Machinists.**

**100 Chestnut St., Philadelphia, Pa.**

## Nichols Transfer Tables Turntable Tractors

**GEO. P. NICHOLS & BRO.  
1090 Old Colony Bldg. CHICAGO**

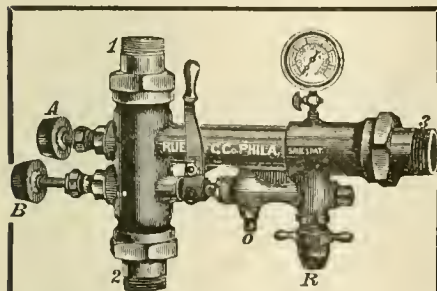

### NOW IS THE TIME to install a Rue Boiler Washer and Tester,

For you will need it when cold weather comes. It will wash out, test and fill your boiler, all with hot water, and have it ready for use in one hour.

THINK IT OVER.  
Catalog on Boiler Washers A-5.  
Catalog on Injectors B-5.

**Rue Manufacturing Co.,  
228 CHERRY STREET  
Philadelphia, Pa.**

Manufacturers of Injectors, Ejectors,  
Boiler Washers and Testers, Boiler Checks,  
Check Valves.



## ASHTON POP VALVES AND GAGES

The Quality Goods That Last

The Ashton Valve Co.  
271 Franklin Street, Boston, Mass.  
No. 174 Market St., Chicago, Ill.

been taken up by all of the railroads. The list of casualties to what is commonly called trespassers is also diminished, although in a lesser degree, and it is an assured fact that the appalling estimate of 10,000 killed for several years in connection with railroads is greatly reduced last year, and a further reduction may be confidently looked for in the future.

Coming to the exact figures it may be stated briefly that for the year ending June 30, 1915, the total number of casualties to persons was 170,661. Of this number 8,621 were killed, and 162,040 injured. These figures show a decrease under 1914 of 1,681 in the number of persons killed, and 30,622 in the number injured. Of the number killed during the year 2,152 were employees, 222 passengers, and 6,247 other persons, including both trespassers and non-trespassers, showing a decrease under 1914 of 1,107 employees killed, of 43 passengers killed, and of 531 other persons killed. Of the persons injured 138,092 were employees, 12,110 passengers, and 11,838 other persons. These figures show a decrease under 1914 of 27,120 injuries to employees, of 3,011 to passengers, and of 491 to other persons. In the period reported upon in Bulletin No. 56, including April, May and June, 1915, the killed number 2,058, while in the same period in 1914 the number killed amounted to 2,224.

### Sturcke-Watson-Stillman Testing Machine.

Catalogue No. 93, just issued by the Watson-Stillman Company, Aldene, N. J., gives an interesting description of the Sturcke-Watson-Stillman testing machine for cylindrical gas containers, including a discussion of various methods of testing the cylinders and safety discs with which they must be equipped. As is well known, the American Railway Association formulated rules over a year ago providing that shippers of liquefied and other gases must assure the safety of the containing cylinders by providing safety devices, and that the cylinders must be subjected at least once in five years to a test by interior hydrostatic pressure. Each cylinder exceeding 12 inches in length containing gas must be equipped with a safety device. Views are given in the catalogue of the various testing devices manufactured by the company and full directions for the tests are also furnished, and the economy and simplicity of these devices admirably meet the requirements of the regulations. Copies of the catalogue may be had on application to the company's main office at Aldene, or at 50 Church street, New York.

### Railroad Track Scales.

The Bureau of Standards, Department of Commerce, has issued a preliminary

folio in regard to the specifications and capacity rating of railroad track scales, copies of which may be had on application to S. W. Stratton, Director, Department of Commerce, Washington, D. C. The purpose of this circular is two-fold: The first, the presentation of general specifications regarding the design and installation of railroad track scales; the second, the development of a consistent method of rating the capacity of such scales. The entire subject matter of capacity rating may be considered as supplementary to the general specifications, since it deals with the strength of the scale parts.

Only those types of railroad track scales which are in common use, such as the ordinary straight lever type and those generally known as torsion or pipe lever scales are considered. The circular does not aim either to limit the development and use of special scales, such as hydraulic and "fulcrum plate" scales, or to interfere with better or heavier construction in the types commonly used; but rather to establish the minimum requirements of track scales, thus discouraging installations which are entirely inadequate for the service for which they are furnished.

The present circular is issued in preliminary form in order that the benefits of criticism and advice may be realized in the circular as it finally appears. The Bureau will therefore be pleased to receive criticisms and suggestions from those who are interested in the subject.

### Automobile Repairing Made Easy.

The Norman W. Henley Publishing Company, New York, never do things by halves. The work before us by Victor W. Page, M. E., contains all there is of the above subject. It extends to 1,056 pages, with 1,000 specially made engravings, and 10 folding plates, and is sold at three dollars per copy. When we state that it contains a comprehensive, practical exposition of every phase of modern automobile repairing practice we do more than echo the claims of the publishers. We know whereof we speak, and our views are corroborated by many automobile users of our acquaintance. The work takes its proper place as the standard work on the subject, and is entirely founded on practical experience and has the rare merit of being free from those involved problems with which some learned men love to becloud themselves. There is not a dark page in Page's work.

### Uncertainty—The Railroad Disease.

An address by Mr. Ivy L. Lee made before the American Association for the Advancement of Science at Columbus, Ohio, last month, has just been published in pamphlet form, and is sure to attract much attention among railroad men. Mr. Lee's long experience in railroad service

eminently qualifies him to present his views and he has come to the conclusion that the distinguishing fact about the system of railroad regulation which has so far been developed in this country is that it is indefinite, inconsistent and not yet established on recognized principles—in other words, that there is nothing certain but uncertainty. As a sample of absurdity it may be noted that when the five per cent. advance rate was allowed by the Interstate Commerce Commission, a declaration was made that the additional amount should be obtained through various suggested methods other than the horizontal increase in rates. When the railroads sought to put into effect the suggested methods, the Commission, upon further consideration, forbade what it had in principle recommended. It takes men like Mr. Lee to show the kind of men of which our Commissions are composed. The future may see some amendment in their personnel, but we are not praying for miracles.

#### "Kewanee."

A series of unique bulletins have been published by the National Tube Company, Frick building, Pittsburgh, Pa. Interesting experiences with Kewanee Unions is a series by itself. There are twenty-four of these interesting, illustrated publications. They are all marked by originality in design, and all convey a convincing argument in favor of the justly celebrated Kewanee Unions. In the one before us there is a lurid story told by an engineer, whose name will be furnished by the company on request, who regretfully failed to persuade his employers to use Kewanee Unions. They were always troubled with leaky steam connections. The place is cracked up now, whatever that means. It is left to the imagination. Doubtless there has been a serious explosion, a sheriff's sale, and very likely some yards of crape showing a flag of distress as a memento of the stick-in-the-mud methods of some fossilized barnacles who refused to keep pace with modern improvements. Send for sample bulletins to the company's office. Whatever may be the matter with other unions, we know that in the Kewanee Union there is strength.

#### "Reactions."

This quarterly publication devoted to the science of Aluminothermics sustains its high character for furnishing details on welding by the Thermit process of all kind of iron or steel fractures in every imaginable situation. In the present issue the performances shown are more complex than ever, as many as four welds being made on one short portion of a locomotive frame, and in another instance a weld 24 inches in length by 4 inches in

thickness made on another frame near the cylinder. In fact, there seems to be no limit to the adaptability of the Thermit method of welding to any part of the modern locomotive. An instance is given of the welding of a mud ring without loosening the boiler sheets. In the mere matter of economy it is unquestionably the most important improvement on locomotive repair work. Frame fractures especially that formerly would have taken over three weeks to repair are now completed in less than three days. Keep informed and send for a copy of *Reactions* to the Goldschmidt Thermit Company, 90 West street, New York.

#### Landis Threading Machines.

Catalogue No. 22, issued by the Landis Machine Company, Waynesboro, Pa., is just issued and furnishes descriptions and illustrations of bolt threading, bolt pointing, nut tapping, pipe and nipple threading and pipe threading and cutting machines, together with screw cutting die heads and chaser grinder. Elsewhere we publish a descriptive article illustrating the company's latest designs of bolt threading machines, which are meeting with much popular favor. The catalogue, however, furnishes complete details of these various machines with dimensions and other interesting matter. Copies of this interesting publication, which extends to 78 pages, may be had on application to the company's office at Waynesboro, Pa.

#### President Wilson Before the Railway Business Association.

President Wilson was the only speaker at the Annual dinner of the Railway Business Association held in New York on January 27. Over 500 members were present and an equal number of guests. The President got a very enthusiastic reception. His speech was largely explanatory of his foreign policy.

#### Naturalization.

Any foreigner may become a citizen of the United States, but in order to do so he must:

1. Live in this country five years.
2. Declare on oath before a court that it is his intention to become a citizen. This declaration may be made as soon as he arrives, or at any time.
3. After the declaration he must wait two years.
4. After that if he can prove that he has resided five years in the United States, and one year in the State, where he then lives, he may be admitted as a citizen.
5. He then, before the court, must deny all allegiance to the sovereign of the country from which he came, and swear to support the United States.

## Locomotive Engine Running and Management

By ANGUS SINCLAIR

This popular book has been a **RELIABLE REFERENCE** and comfortable unfailing **POCKET EDITION.**

PRICE, \$2.00

**ANGUS SINCLAIR CO.**

114 Liberty St., New York

## STEEL STAMPS

INSPECTORS HAMMERS

Hand Cut STEEL LETTERS & FIGURES

LATHE TOOLS, TIME CHECKS,

Noble & Westbrook Mfg. Co.

9 ASYLUM ST. HARTFORD, CONN.



## The Armstrong Automatic Drill Drift

IS DRIFT AND HAMMER COMBINED.



Pat'd  
June 16  
1908

The handle or driver is always ready to strike a blow as the spring automatically throws it back into position.

LEAVES ONE HAND FREE TO SAVE THE TOOL.

Special Circular mailed on Request.

**ARMSTRONG BROS. TOOL COMPANY**  
312 N. Francisco Ave., CHICAGO, U. S. A.

NEVER SHRINKS OR DETERIORATES



ESPECIALLY PREPARED FOR THE ENGINEER

WORKS EQUALLY WELL ON HOT and COLD SURFACES

CLEANS POLISHES and PRESERVES ALL KINDS OF METALS

**GEO. WM. HOFFMAN CO.**

Indianapolis

New York

Chicago

San Francisco

Send for FREE Sample

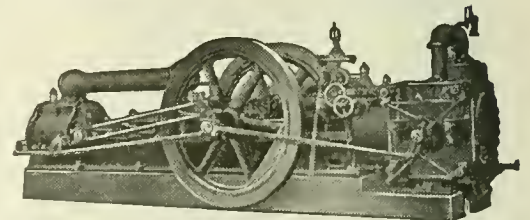

## The Norwalk Iron Works Co.

SOUTH NORWALK, CONN.

Makers of Air and Gas Compressors

For All Purposes

Send for Catalog

# Railway AND Locomotive Engineering

A Practical Journal of Motive Power, Rolling Stock and Appliances

Vol. XXIX.

114 Liberty Street, New York, March, 1916.

No. 3

## Triumph of Grade Reductions and Other Important Improvements on the Canadian Pacific Railroad

Among the remarkable improvements in grade reductions on the principal railroads in America it is doubtful if there is in America a better illustration of what may be done in the way of grade reduction in mountainous regions than the improvement of the Canadian Pacific railroad line

latter to the Roger's Pass tunnel that is being driven through Mount Macdonald in the Selkirk Range.

Prior to 1908 these two stations were separated by such extreme grades that four 154-ton consolidation (2-8-0) locomotives were required to haul a trainload

driver of a descending train signalled to the switchman that his train was under control, the normal setting of one of these switches would divert the train to a catch siding.

Increase in the density and extent of traffic made great reduction practically a

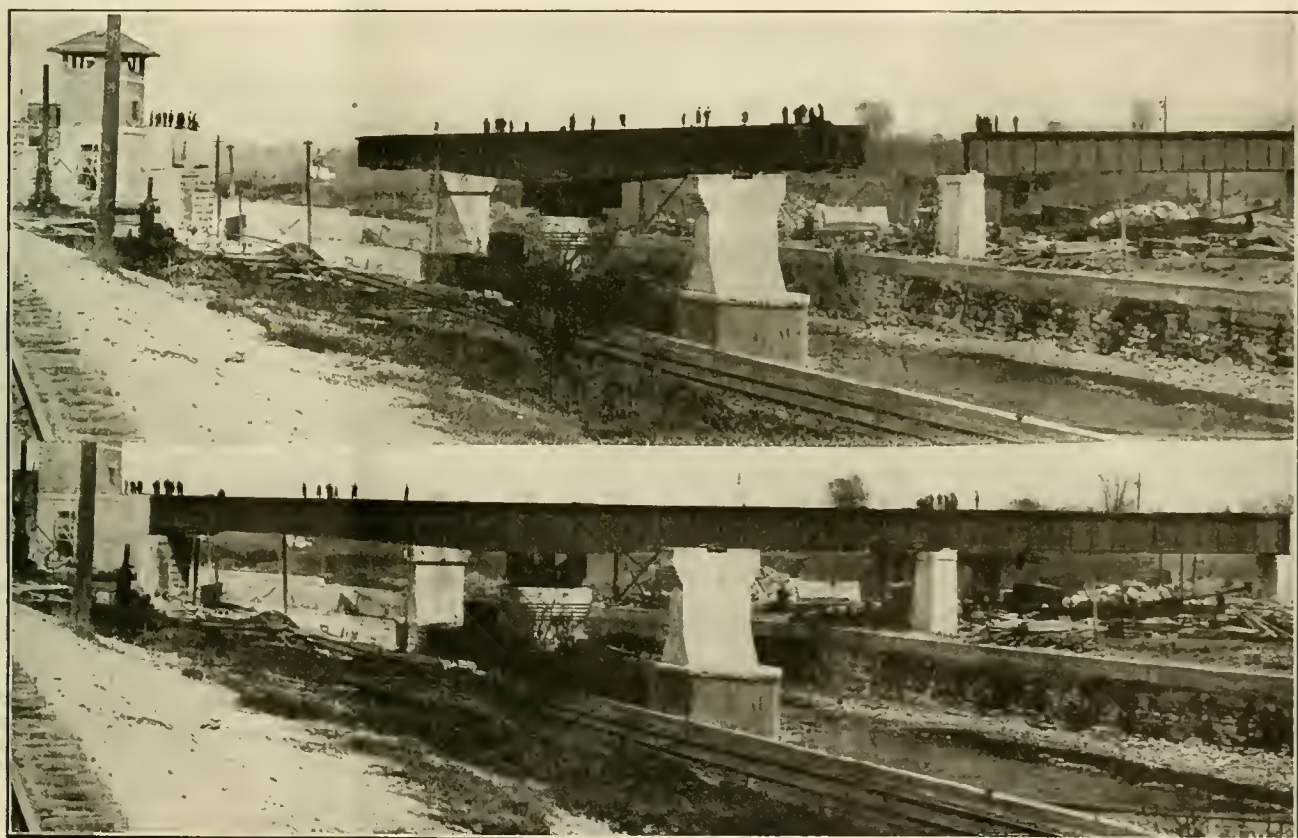

THE LACHINE CANAL SWING SPAN IN ITS OPEN AND CLOSED POSITIONS.

in British Columbia. It has involved the construction, some six years ago, of one of the most interesting systems of tunnels in existence, and also the construction, now under way, of the longest tunnel on the continent. We refer in the former instance to the spiral tunnels in the valley of the Kicking Horse River, and in the

of 710 tons of freight over this section of the main line. For about three miles a grade of 4.5 per cent. prevailed, decreasing to 4 and 3.5 per cent. for the remainder of the distance. These grades involved the use of spring switches at different points along the line for the purpose of safety. Unless the engine-

necessity. Reference to Fig. 1 will enable the reader to clearly understand the manner in which this was accomplished. The main line now traverses the valley of the Kicking Horse River between these two stations with an increased length of 8.2 miles and a maximum grade of 2.2 per cent. (compensated).

This development of length was rendered a difficult problem owing to the steep mountain sides on either bank of the river. The only solution lay in tunnelling a loop on each side and in the construction of bridges, as shown in the sketch. The driving of these spiral tunnels has been regarded by many engineers as one of the most interesting en-

improved to this extent, two engines of the same class as the four previously used can haul 980 tons of freight up the valley.

The spiral tunnels were driven through crystallized limestone of a widely distorted nature. In places, the stratification would vary from nearly horizontal to almost vertical, and in others from normal

tion of the Selkirk portion of the line from 4,330 feet to 3,791 feet. In reducing the maximum grade, one of the most costly sections, from an operating point of view, will be eliminated. The large force of pusher engines, snow ploughs and equipment shops that have necessarily carried on a busy existence at Roger's Pass in service on both sides of the Selkirk Range, will shortly have to seek other quarters.

Besides necessitating about 18 miles of new track, the tunnel project involved, in its preliminary stages, a 900,000-cu. yd. fill in the centre of the Illecillewaet River valley, extending westward for a distance of  $1\frac{1}{2}$  miles. Between this fill and the west portal there is a 300,000-cu. yd. cut, the entrance being at a level of about 80 feet below the ground surface. In the east end there is another approach cut of about 100,000 cu. yd.

The work, commenced in June, 1914, will probably be completed in September, 1916, several months before the time stipulated. It is being carried out under the direction of Mr. J. G. Sullivan, Chief Engineer of Western Lines for the Canadian Pacific Railway. Mr. H. G. Barber is the engineer-in-charge.

The cost of this improvement alone will exceed \$12,000,000.

The new electrically-operated, double-track swing bridge, built by the Canadian Pacific Railway over the Lachine Canal, in the Province of Quebec, on the St. Law-



FIG. 1. GRADE REDUCTION WORK ON THE CANADIAN PACIFIC RAILWAY BETWEEN HECTOR AND FIELD, B. C.

gineering features of the whole Canadian Pacific railway improvement.

Tunnel No. 1 is 3,206 feet in length, turning an angle under Mount Stephen of about 234 degrees on a 573-foot radius with a grade, as reduced by compensation, of 1.6 per cent., producing a difference of level at the portals of 48 feet. Tunnel No. 2 has a similar radius of curvature through an angle of 232 degrees.

to almost parallel with the direction of the centre line. The hardness and brittleness of the rock varied every few feet, rendering drilling operations difficult.

About 85 miles west of Field there is at present under construction a double-track tunnel through the Selkirk Range. From portal to portal its centre line will measure 26,400 feet, thereby exceeding by three-fourths of a mile the longest existing tun-



THE CANTILEVER SPANS OF THE ST. LAWRENCE RIVER BRIDGE.

It is 2,890 feet long and the grade produces a difference in elevation of about 45 feet at the two portals. Thus the road now traverses the valley by three lines at different elevations. It crosses and recrosses the river by four bridges. The improvement further necessitated the driving of a 170-foot tunnel, this one on a tangent, before connecting with the old line near Field. With the gradients

nel in America. This tunnel will be finished during the present year. The Selkirk tunnel may be considered an adequate winding-up of vast expenditures and enormous engineering undertakings which the company has carried out with a view to perfecting the alignment and grade of its road both east and west of the great wheat fields of the Dominion. The tunnel will bring down the summit eleva-

rence River, is a triumph for Canadian engineering, and of particular interest to railroad builders. Unique in many respects, and certainly the most up-to-date in North America, this wonderful piece of mechanism is moved with the ease and apparent simplicity of the hands of a watch, although a weight of not less than 758 tons swing upon the central pivot. From the time the railway traffic is closed

till the moment when the waterway is open for steamship traffic is a period of only seventy seconds. When the bridge is open, not only do the interlocked signals at the bridge indicate stop, but the automatic block signals to which they are connected give a distinct indication to

span at the south end of the bridge to accommodate the existing roadway and admit running of a possible railway track along the south canal bank. This span weighs about 143 tons, making a total of 758 tons for the whole bridge. The electric operating power is carried

bridge for canal traffic until all railway traffic is stopped at a safe distance from the bridge.

THE ST. LAWRENCE RIVER BRIDGE.

In regard to other important bridge work, the reconstruction of the St. Law-

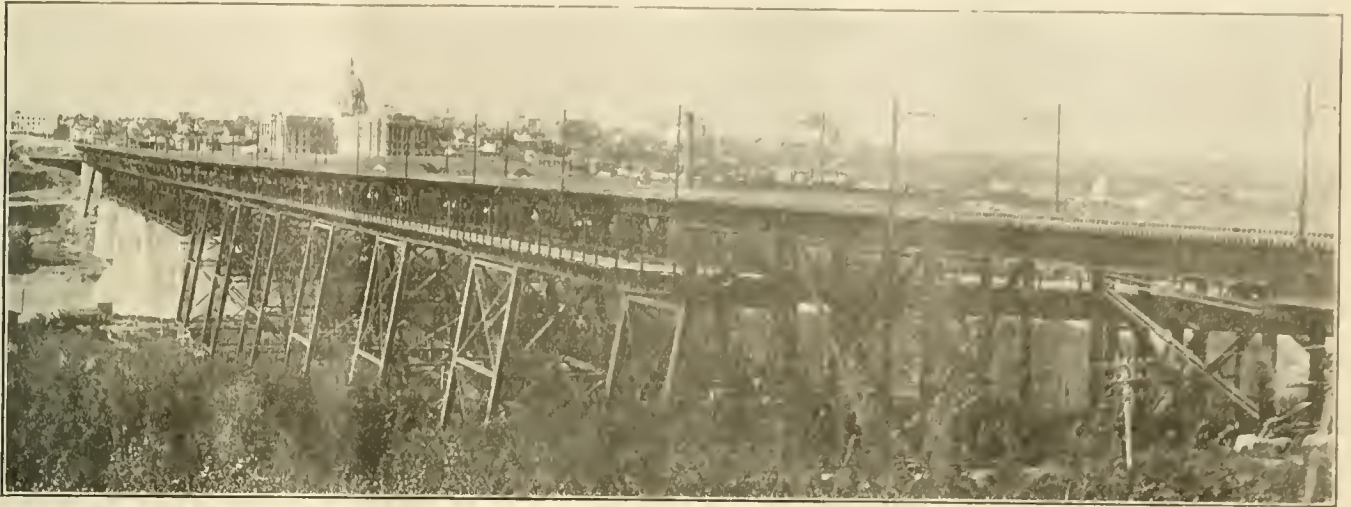

THE C. P. R. BRIDGE AT EDMONTON, SHOWING DEVIATION OF HIGHWAY AT EACH END.

an approaching train that they will find the interlocked signals at "stop" when they are reached.

This plate girder swing span is understood to be the longest plate girder span of its kind ever built, being 239 feet 7

by submarine cables under the canal to the centre pier, and there supplied to duplex 30 h. p. motors which are controlled from the operator's house on the north bank of the canal, and, in addition, a spare 30 h. p. motor is kept on hand

rence River bridge between Highlands and Caughnawaga, about eight miles from the Montreal terminal, is a triumph of a great work being accomplished without interruption to traffic. The old single-track structure was replaced by two



VIEW OF THE RIVER SECTION OF THE OUTLOOK BRIDGE AT LETHBRIDGE. AT THE RIGHT IS ONE OF THE NINE LAND TOWERS.

inches long and 13 feet 6½ inches deep in the centre, reduced to 8 feet ½ inch at the ends measured from back to back of flange angles. There are four girders and the weight of each of these is 112 tons and of the whole swing span 615 tons. There is also a ninety foot

in the house in case of emergency. The bridge is protected by the most modern interlocking machinery, so as to make it impossible for a train to approach the bridge before it is properly closed and safely locked, and, in addition, it is impossible for the operator to open the

parallel single-track bridges designed for heavier loading. The 4,100 tons of steel work in the old structure were replaced by 14,231 tons in the new. The finished bridge, as illustrated, consists of the following spans, viewed from the north end: Three 80-ft. deck plate girders; eight 120-

ft. deck Warren truss spans; four 240-ft. deck Warren truss spans; one 270-ft. and two 480-ft. through Pratt curved chord sub-panelled trusses; one 270-ft. deck Warren truss, and one 120-ft. deck Warren truss.

Another remarkable example of bridge work is the justly famous Lethbridge viaduct, 5,327 feet long, with a maximum difference in elevation between river bed and base of 314 feet. Lethbridge is 759 miles west of Winnipeg, and is a divisional point on the Crow's Nest Branch of the Canadian Pacific railway. There were formerly twenty smaller bridges. The territory included grades 63.4 ft. per mile. The grades are reduced to 21 ft. per mile. Thirty-seven curves were eliminated. The viaduct consists of 44 plate girder spans 67 ft. 1 in. long, 22 plate girder spans 98 ft. 10 in. long, and a riveted deck lattice truss span 167 ft. long. It is carried in 33 riveted steel towers, rigidly braced. The design is shown in the last illustration. The substructure consists of concrete piles supporting concrete pedestals. A 3-degree curve exists at the western approach and a 1-degree curve at the eastern approach. There is a grade of 0.4 per cent. rising towards the west for the entire length. It is the largest work of its kind in the world.

#### Northern Railway of France in War Time.

The Nord railway of France has suffered more through the war than any other French railway. In September, 1914, only 414 miles, or 18 per cent. of the total network of 2,324 miles, was actually being operated by the company, which indicates the invaluable military services which the Nord rendered during the earliest stages of the war. Today the company is operating a total length of about 1,200 miles, or 51.5 per cent. of the entire system. Of the 768 stations on the system, 346 are at present either occupied by the enemy or closed to traffic. Not all the remaining 412 stations are open to the public, a certain number being exclusively reserved for military purposes. The actual situation is that for over a year the Nord has been deprived of the use of most of its great arteries, and the only double-track main line now available is that from Paris to Creil, Amiens, Boulogne, Calais and Hazebrouck.

#### Proposed Railway in Lapland.

With the co-operation of the Norwegian Government the Government of Finland is planning to construct a railway along the western and northern borders of Lake Enare to the mouth of the Neida river at the Arctic Ocean, which is open all the year. The length of the railway would be 280 miles, at a cost of about \$31,000 per mile.

#### New School on the Baltimore & Ohio.

The employees of the Baltimore and Ohio railroad in the freight department have organized a class for the study of matters pertaining to their department. The prescribed course will require eighteen months. Mr. C. G. Roberts, chief rate clerk is in charge and with a staff of assistants has opened class rooms in Pittsburgh, Pa.

#### Passenger Rates in New York.

Many facts unknown to the public, calculated to prove that a readjustment of passenger rates to a uniform basis of 2½ cents a mile in New York State is necessary were presented by the representatives of the New York Central Railroad to the Interstate Commerce Commission last month. The statement clearly proves that in State traffic the revenue is actually less than the expense in carrying passengers. Payments on labor have increased 45 per cent. in the last ten years, and other items in almost equal proportion, while the railroads are held down to ancient rates.

#### Railway Extension in Bolivia.

The Bolivian government is to issue a call for tenders for the construction of a railroad from Potosi to Sucre, according to a recent issue of the *South American Journal*. The new railway will be an extension of the present line to Potosi from Rio Mulato, which is on the Antofagasta & Bolivia Railway, making a total length of 215 miles on this branch line. The bids for construction, which must be presented before June 30, 1916, are to conform to detailed plans already formulated.

#### Goggles for Erie Men.

The Erie Railroad Company will furnish goggles to employes on hazardous tasks. During the last four months 289 employes received injuries to their eyes, including the total loss in five cases. It is said this will cost \$10,000.

Employes will be required to use the authorized standard goggle provided by the company. The goggle has a ground lens, the advantage of which is its clearness and freedom from prismatic effects. The composition of the glass is of such a nature that even a blow of sufficient force to break it will not endanger the eye, as the glass will not chip.

#### Purchase of the Manila Railroad.

Governor General Harrison has recommended that the legislature ratify an agreement for the purchase of the Manila railroad, capitalized at 8,000,000 pesos, with payment immediately of 4,080,000 pesos available in the insular treasury, and of the balance in eighteen months. The government already has financed the

construction of the road to the extent of 6,000,000 pesos, but the war has prevented the English company in charge of the construction from obtaining funds to complete the work.

#### Railway Apprentices in Italy.

According to information furnished by the Director General of the Italian State Railways, firemen are chosen from the ranks of the young mechanical workers who have attended the ordinary elementary State schools and who must then pass a competitive examination. Upon their entry into the service they are given a special theoretical course by engineers and receive practical training by working in the machine shops. Six to nine months are required to complete this course, after which each candidate must undergo further examination, and if successful, is admitted as fireman on a locomotive.

#### Goggles on the Baltimore & Ohio.

To the general use of goggles by mechanics the company's physician attributes a prevention of fifteen injuries to employes' eyes on one division, while on another division there were ten instances of the protection provided by the railroad having saved the sight.

#### Cleaning Machines in Germany.

It is announced that machinery and parts of same may be cleaned without benzine and benzol. Parts of machines are boiled in soda lye, then brushed while the lye is still hot, and afterwards rinsed in hot water. Caustic soda is better than common soda, since it causes the fat or grease to dissolve quicker. In order to dry the hot parts it is only necessary to let the remaining particles of water evaporate.

#### Excessively Fast Trains.

The general managers of one of the transcontinental lines said to the writer, that if it were possible to shoot passengers from New York to Chicago in three hours, with a loss by accident of three per cent., he believed that the average American traveler would patronize such a system. There is a fascination in rushing past mile posts for nearly all passengers except those responsible for keeping up rolling stock and roadbeds. The craze cannot be said to be based on a desire to reach the destination in the shortest possible time. A reduction of two or three hours in time between New York and Chicago would not affect the business interests of one person in a hundred, yet most of the people who travel between these two cities insist on using the fastest trains. Every effort made by railroad companies to reduce the speed of through trains meets with strenuous opposition from travelers.

# The Factor Which Determines the Choice of Single Shoe or Double Shoe Foundation Brake Gear

By WALTER V. TURNER, Assistant Manager Westinghouse Air Brake Co.

The consideration which determines the choice of a brake gear is the distance in which it is desired to stop the vehicle. The distance in which the stop can be made, other things being equal, and up to the limit of the rail adhesion, is determined by the realized pressure of the shoe upon the wheel. If this maximum realized shoe pressure is less than the downward pressure on the wheel, due to the weight of the vehicle, a single shoe foundation brake gear may be employed, as the shoe may be located on the approximate horizontal center line of the wheel without causing trouble.

If the maximum realized pressure on the shoe exceeds the downward pressure on the wheel, due to the weight of the vehicle, a double shoe type of foundation brake gear should be employed, since it is not possible to locate the shoe on the approximate center line of the wheel without risk of journal and other troubles.

To avoid such troubles by locating the shoe a sufficient distance below the center line of the wheel, is only to choose other evils, since then the brake cannot operate or be operated properly. Such brake action as remains causes train handling to be very rough, and there is also a very greatly increased train resistance.

If the one factor above mentioned, which should determine the design, is ignored and, in order to get away from excessive lateral pressure, the brake shoe is dropped on the wheel and the evils inseparable from this are tolerated, there eventually comes another factor into consideration which may decide the question as to whether a single shoe or double shoe type of foundation brake gear is employed. This is the limit of pressure to which the brake shoe may be subjected. This, however, cannot be resolved into the question of weight of vehicle, since it is possible that the pressure on the shoe may be greater with a car weighing 100,000 lbs., than is the case with a car weighing 130,000 lbs.—this depending upon whether the car has a 4-wheel truck or a 6-wheel truck, and again upon what the braking ratio of either of such cars may be. Thus, it will be seen that no matter how the solution of this question is approached, the weight of vehicle "per se" is not a factor in the problem.

As far as passenger carrying service is concerned, the air brake devices available, including also those electrically operated, have for all practical purposes unlimited capacity and efficiency—the realization of which, however, does and must depend upon an adequate foundation being provided. For instance, how foolish it would

be to build a modern locomotive and try to run it on a 50-lb. rail. Every one has sense enough to put down a suitable rail for the locomotive to run on. In like manner, the air brake performance depends for its capacity and efficiency upon truck and "foundation" brake gear construction, for as a chain is no stronger than its weakest link, so the brake is no more efficient than its least efficient part,

erally speaking, is way below par. The foundation brake gear and air devices must be considered as one; that is, as the brake.

The truck, strange as it may seem when we consider that the same consideration is not given to it for the foundation brake gear, is built strong enough to carry the car; therefore, as far as strength is concerned, nothing is requested in this di-

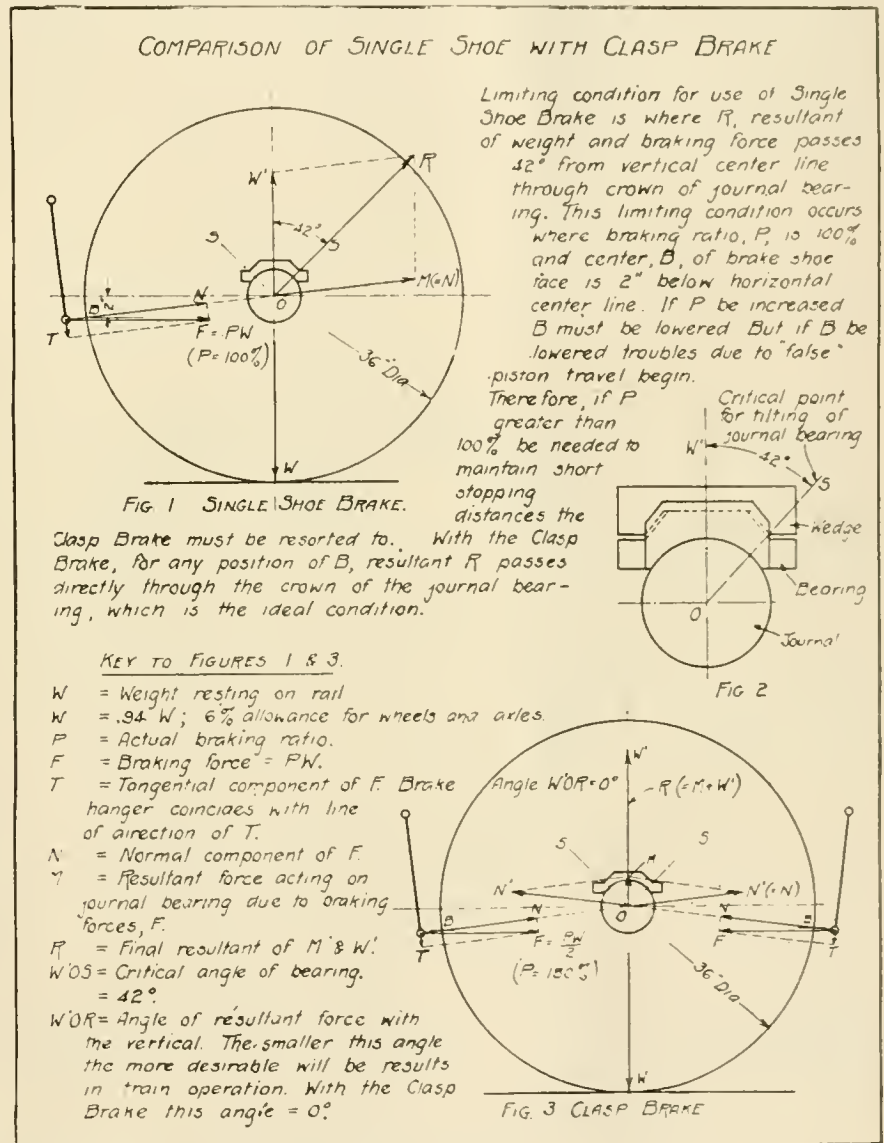

which now is the truck and the foundation brake gear. In other words, not only does smooth, accurate and effective brake control for service; that is, ordinary stops, depend upon these two elements, but the emergency stopping distances are determined now, not by the capacity and efficiency of the air devices of the brake, but by the efficiency of the means for delivering the brake cylinder force to the wheel and the rail, which means, gen-

eration, but seldom is provision made in the truck construction for an adequate and efficient foundation brake gear.

To be adequate, where the work to be performed by the brake shoe so increases the temperature of the shoe that its coefficient of friction is materially reduced and thus even greater shoe pressure has to be employed if the same stopping distance is to be maintained; that is to say, the braking ratio has to be increased, the

foundation brake gear must be of the two-shoe per wheel clasp type, since the retardation necessary for economic railroad operation always requires a braking ratio above 100 per cent., and it is this one factor alone that determines whether the single shoe or two-shoe type of brake should be employed, as I hope the following will make clear.

With a single-shoe type of foundation brake gear, to obtain the most satisfactory operation of the brake, it is necessary to have the brake shoes on the horizontal center line of the wheel. This insures most nearly a constant and uniform proportion of brake cylinder to the auxiliary reservoir. Two inches below the center of the wheel, however, is not radically detrimental in this respect and has some advantages which probably make 2 inches below the center of the wheel the most nearly desired location.

If the brake shoes are hung 6 inches below the center line of the wheel, the resolution of forces is such as to result in a material decrease in piston travel when slack adjusters are employed (If slack adjusters are not employed, the brake may be lost, due to the piston striking the brake cylinder head.) This completely destroys the designed relation between the auxiliary reservoir and the brake cylinder, with the result that low cylinder pressures are not obtainable and also the time in which the brake cylinder pressure is obtained is materially shortened, which results in the brake operation being very unsatisfactory and rough; also, in flat wheels, stuck brakes, greatly increased train resistance, etc.

It would seem then to be inexcusable to hang the brake shoes more than 2 inches below the horizontal center line of the wheel, but this, while wrong, was done to avoid other evils; namely, that when the braking ratio had to be raised to above 100 per cent. in order to properly control the vehicle, the lateral pressure was so great as to crowd the journals from under the brasses, break the pedestal jaws, cause hot boxes, and other kindred evils. Thus, to avoid this evil, the one above referred to was incurred, but both are so bad that neither should be tolerated, since it is not obligatory that they should, for a properly designed clasp brake will avoid both.

If the above-mentioned inefficiency and troubles are to be avoided, a clasp brake

should be resorted to whenever the shoe pressure on the wheel, due to braking force applied at a point 2 inches below the horizontal center line exceeds the downward pressure on the wheel, due to weight of vehicle. In other words, whenever the maximum realized braking ratio is 100 per cent. or more. (This may mean anywhere from 110 to 125 per cent. nominal braking ratio, according to the efficiency of the foundation brake gear, etc.)

The accompanying diagram T-1351 will illustrate this point. Thus, it will be seen that notwithstanding some views to the contrary, the weight of the vehicle is not a factor in determining when clasp brakes should be resorted to. To illustrate: What necessarily follows, if the car weight or weight on the wheel is used as the determining factor of when clasp brakes should be employed, is that every modern freight car would have to be equipped with clasp brakes if braked on their loaded weight (a basis on which cars are now being braked as representative of the most modern practice). Obviously, this is not the case, for even when braked on its loaded weight the braking ratio does not exceed 45 per cent. for the freight car, while the passenger car reaches 150 per cent., or even more, the total car weights (the loaded freight car and empty passenger car) being the same in both cases. This shows the fallacy of using car weight instead of braking ratio as the determining factor.

Nor is the question of permissible limit of shoe load a determining factor, for it is evident that in meeting the brake requirements, the braking force on the wheel may exceed the downward pressure, due to the weight of the vehicle, long before the breaking-down point on the brake shoe metal is reached. In other words, if proper consideration is given in a design to avoiding the two evils, first above mentioned, namely (1st) excessive unbalanced lateral pressure with its bad results, and (2nd) the injurious and detrimental effects of "false" piston travel in train operation, all other evils will be automatically eliminated, since the cause of these two is reached long before consideration need be given to the others.

Inasmuch as nearly all modern passenger cars have a braking ratio exceeding 100 per cent., it is evident that clasp brakes should be the only foundation brake gear installed, if excessive lateral

pressure on the wheel on the one hand and intolerable brake action on the other, with all their attendant evils, are to be avoided.

IN MODERN PASSENGER TRAIN SERVICE, THE FOUNDATION BRAKE GEAR IN GENERAL USE IS RESPONSIBLE FOR:

1. Rough handling of trains in:
  - a. Starting—violent "taking of slack" necessary to get train under way.
  - b. Slowing down.
  - c. Stopping.
2. Inability to make the time because of:
  - a. Hard pulling train—due to dragging brake shoes and stuck brakes.
  - b. Long drawn out stops—"dribbling on" brakes in attempt to avoid shocks.
  - c. Delays due to hot journals, stuck brakes, and damage arising from shocks.
3. Unwarranted expense in:
  - a. Excessive fuel and water consumption.
  - b. Reduced capacity of engine.
  - c. Slid flat wheels due to shocks and stuck brakes.
  - d. Damage arising from shocks even to the extent of break-in-twos.
  - e. Hot journals.
  - f. Burned brake shoes and brake heads.

Note on 3 (a and b):

For an easier pulling train, the same locomotive can haul more cars with the same steam consumption, or the same number of cars with less steam, the schedule time being the same in each case. The Lake Shore Brake Tests in 1909 revealed a possible saving of 35 per cent. in either reduced steam consumption or increased locomotive rating due to the elimination of false piston travel.

A well-designed clasp brake eliminates false piston travel as no other device can possibly do.

The superheater has been adopted as standard on the modern locomotive because of the 25 per cent. saving in fuel consumption realized over the saturated steam locomotive performance and the several attendant advantages. By the general adoption of a suitable design of the clasp brake for modern passenger cars a fuel and water saving may be realized equal to, if not greater than, that gained by the introduction of the superheater.

## Filling Flat Spots on Tires

By F. A. WILLIAMS, Engine House Foreman, Rutland Railroad, Alburgh, Vt.

Much interest has been raised by occasional reference in your pages to the use of welding appliances in filling flat spots on tires of locomotive driving wheels. The first use of the appliance heard of in this part of the country was in 1911, on the Bangor and Aroostook railway when Mr. Hugh Montgomery

was superintendent of motive power, and an Oxweld Acetylene machine was used filling in some skidded drivers. The Midvale Steel Company sent representatives to the shops at that time to report on the work, and as the application of the device is now a great saving to many railroad companies, it would be interesting to

know where and when the first attempts at such work was made. Probably some of you readers might be able to enlighten us as to previous uses of welder filling on skidded wheels. Doubtless any such information would be gladly published in the pages of RAILWAY AND LOCOMOTIVE ENGINEERING.



# Locomotive Running Repairs

By JAMES KENNEDY

## VII—Refitting Driving Boxes

It may be regarded as a certainty that the inevitable wear of the bearings of the axles of locomotives both as applied to the axle, and also to the hubs of the driving wheels render the refitting and also the reinforcing of the driving boxes an occasional necessity. However carefully fitted, the driving boxes may have been, it will soon be found that there is lost motion in their relation to the axle and also in their lateral adjustment that calls for a refitting of the parts. The setting up of the wedges not infrequently augments the trouble instead of remedying the defect, for it will be readily understood that in the event of any heating of the driving box, if the wedges are snugly set up, there is no room for any expansion of the box between the wedges. This will hasten the wear of the brass as the driving axle will crush the particles of the softer metal in its revolving path and it will frequently be seen after a driving box has been heated that a quantity of brass dust will be found in the cellar of the driving box. The box having assumed its normal condition, or nearly so, after cooling the line of curvature of the bearing will be in excess of that of the axle and hence a loosening of the bearing with an increase of pounding, and increased wear and tear in all of the other dependent parts.

When refitting has become absolutely necessary, the degree of looseness on the axle and the amount of lateral motion between the hubs of the wheels will determine the exact mode of procedure. If there is a sufficient quantity of metal remaining in the brass to bear a reboring and if the lateral wear is not excessive, it is good practice to cut a recess on the side of the box next the wheel sufficiently wide to embrace all of that portion of the hub of the wheel that comes in contact with the outer face of the driving box. This will extend to about 5 ins. This recess should at least be nearly half an inch deep to give solidity to the liner to be applied to the side of the box. The outer edge of the recess should be dovetailed at least one-sixteenth of an inch to prevent any loosening outwards of the liner. A still deeper recess should also be cut in the center of the larger recess, which should extend to at least one inch in width. This second or deeper recess to be dovetailed on both its outer and inner edges, in order to prevent any movement of the liner in either direction.

In addition to these recesses two or

three notches may be cut with a flat chisel on both sides of the inner recess, thereby preventing any tendency to revolve on the part of the liner. In applying the molten metal to the prepared recess on the side of the box there is usually a strong horse-shoe-shaped outer piece of iron, half an inch at least in thickness and one inch or more in width. This forms the outer or extreme edge of the proposed liner. An inner shell can readily be fitted into the bearing of the box, of an equal height or projection above the box. The two pieces are then covered and held together by a suitable

rush, unless prevented, to the outer air. It will be found that there is no need of tap bolts or other appliances to insure the fixity of the liners. Other methods and other materials are used in many of the leading railroad shops in dealing with the outer faces of the driving boxes as well as the inner hubs of the wheels.

In some shops the practice of applying babbitt liners to the boxes is approved. The best method of applying this metal, of which there are various kinds of mixtures, is after cutting the recess on the face of the box, to heat the box sufficiently to allow of the process of tinning

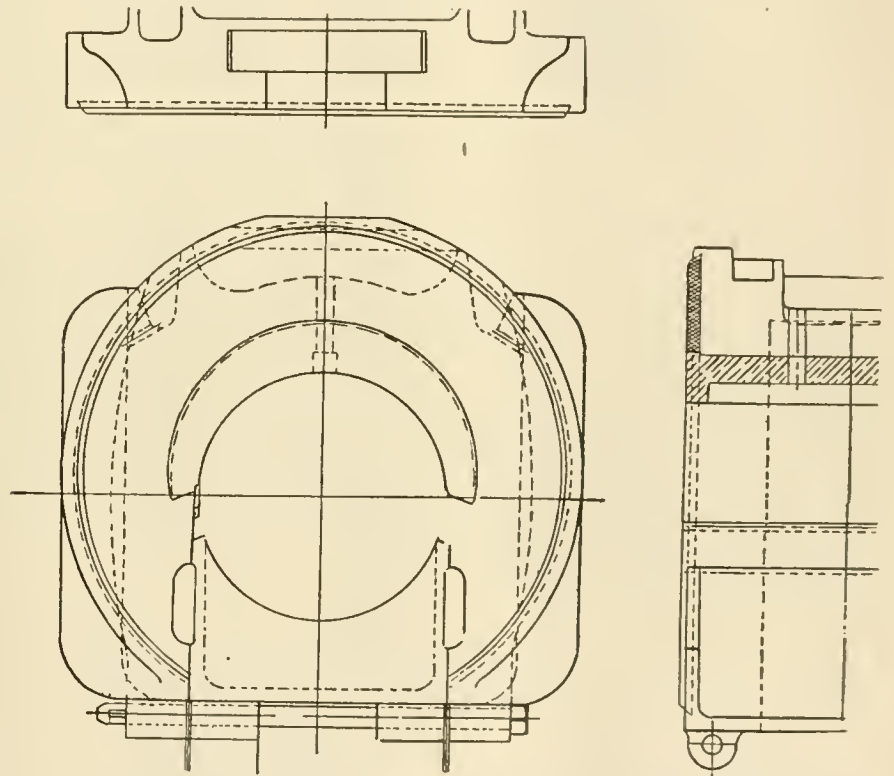

DRIVING BOX WITH PATCH OR LINER ON SIDE NEXT WHEEL.

flat attachment. Some mechanics apply a slight coat of crude or other inflammable oil to the surface of the recessed portion of the box, and when the molten metal is applied it will be found that the burning of the oil has the effect of preventing the formation of air cells in the applied metal. This is especially the case in the use of bronze or other alloys containing sulphur, these compounds generally having a coarse crust forming on their outer surfaces. This tough coating or scum frequently prevents the complete escape of the bubbles of oxygen or other gases that spontaneously coalesce and

the surface of the box where the babbitt is to be applied, the heating being speedily accomplished by a small portable, covered furnace. When the box is tinned in advance of the application of the molten babbitt, the babbitt rarely loosens.

It is also found that where babbitt is used on the box the application of a steel liner on the hub of the wheel makes a bearing of great durability and smoothness of running. The recess in the hub of the wheel need not extend over a quarter of an inch in depth. The disc when turned to the required size is cut into two equal pieces and held in the re-

cess by three tap bolts in each piece, the tap bolts being carefully fitted to counter-sunk recesses in the semi-circular reinforcement plates.

It may be mentioned in relation to the subject of smoothness of running that there have been recently introduced some improvements in the construction of driving box brasses looking in this direction, which, although small in themselves, tend to aid in the approach to that degree of perfection essential to the modern locomotive. Among these the method of cutting the oil grooves in the crown or sides of the casting instead of having the recesses rough cast in the mold commends itself. The grooves cut after casting may be relied upon as not containing sand or other impurities, which is difficult to completely remove from castings where such grooves are roughly formed in the casting.

A simple method of securing the brass in the box may also be alluded to. In reducing the outer surface of the brass to the required size a small collar may be left on the larger end of the brass. On the opposite side of the box a slight bevel or chamfer may be made by a few strokes of a rough file, and when the brass is pressed into place in the box, the projecting edge of the brass may be readily riveted over. This simple combination of a small collar on one side and a slight spreading of the metal on the other side precludes the necessity of drilling holes through the brass and box and fitting pins to hold the brass in place.

Coming to the fitting of the box, it will be seen that the most careful boring out of the box can at best only make a near approach to the exact fit required, and as there are not infrequently slight variations in the diameter of the axle at the different ends of the bearing, the proper

fitting of the driving box, especially in the case of high-class passenger locomotives, is an operation requiring fine mechanical skill. The increasing weight of these boxes has now become so great that heavy appliances have been devised for raising or lowering them to and from the axles. Where it is not convenient for the traveling cranes to reach portable cranes are called into operation, and we have recently seen small cranes that may be readily moved from place to place by a traveling crane and deposited at the desired point. These were equipped with electric motors and pulleys slidably engaged on an extended arm which was counterbalanced by a heavy weight on the opposite side of a strong central structure resting on a heavy base, forming at once a very reliable and flexible means of moving the heavier kinds of driving boxes from place to place. With lighter boxes an improvised crane may readily be bolted by an adjustable strap to the center of the axle, and the box swung into the desired position by a chain running in a suitably grooved pulley, the arm supporting the pulley being furnished with a swivel joint on an upright arm attached, as we have stated, by a strap to the axle on which the boxes are being fitted.

Pieces of wood or corks should be fitted into the oil holes from the inside before beginning to use a file on the bearing. This obviates the necessity of hammering the box for the purpose of loosening the adhesive filings. There are very few evil practices so common in railroad shops as the hammering of driving boxes to jar the filings from their lurking places. Driving boxes of the smaller kind may be readily sprung by this practice until the box may be rendered unfit to admit of the cellar and the bearings on

the box for the reception of the wedges are not parallel. A constant repetition of hard hammer blows upon the top of the box cannot fail also to affect the elasticity of the metal and hasten the crystallization of the part repeatedly struck, so that in time the metal will readily crack or break after a comparatively short period of service.

In this relation it should be remembered that all work on the top of the box, including the cutting of oil ways and fitting saddles should be done before the box is fitted to the axle. The fitting should be the last operation; as any other work that may be done upon the box after being fitted to the axle has a tendency to affect the exact relation of the bearing to the axle. The fit should be the best possible, and it is good practice to fit the bearing so that it bears lightly on the crown of the box, the fit being snug at both sides, special care being taken that there is something less than half a circle in the entire bearing. In regard to the oil ways the best practice is to have a deep oil way cut in the crown of the bearing from which grooves may be cut by hand or compressed air chisel leading angularly across the upper part of the entire bearing, so that the oil may reach every part of the axle bearing freely. In the case of the use of grease it is advisable to cut two grooves, at least one inch in depth. These grooves should be equidistant from the crown of the bearing and at sufficient distance to divide the bearing into three equal parts. The preference for two grooves when grease is used as a lubricant becomes apparent when it is borne in mind that grease possesses greater viscosity than oil, and even when partially heated does not flow so freely.

## Electric-Arc Welding

### Its Advantages In the South Beyond Controversy

By R. G. SMITH, SAVANNAH, GEORGIA

Your able correspondent, C. Richardson, writing on the subject of Electric-Arc Welding of Flues in the February issue of RAILWAY AND LOCOMOTIVE ENGINEERING, states his case very clearly in regard to the disadvantages of arc-welding in his locality, presumably on one or other of the New England roads, where it is generally admitted that there is room for improvements. I feel, however, that issue must be taken with him in regard to the general use of the electric arc-welder in other localities, and whether it may be that the boilers that he has practiced upon may, very likely, have had their flue sheets already burned out, and are past remedy, or whether it may be that by heaping too much metal upon the bead

of the flues, which, of course, has a weakening effect upon the intercostal bridges between the flues, it is not the system but the improper use of it that leads to the disadvantages to which he has referred.

Our experience in the South has been that the advantages of welded flues lie in the fact that they become practically permanent, as the flue and sheet are solidly bonded together without a joint. In the absence of scale or other troubles, which can be avoided by taking proper care, the flue would remain in place and no crack in the sheet develop for an indefinite period, were it not for the limitation of the three years Federal law. No better proof of this could be given than

an extract from the proceedings of the International General Foremen's Association, and which is published in the volume of their proceedings as a part of the report on autogenous welding and refers to the experience on the Central of Georgia Railway:

"A field in which electric welding has proved very successful and profitable is that of welding flues to back flue sheets. We have in service today over ninety locomotives with flues welded to back flue sheets, making a total of about 27,000 flues. Out of this number of locomotives in service with flues welded, we have our first engine to fail on line of road with flues. We have, however, had some flues to leak after being in service a short time,

but this was due to bad beads on flues when welded in. If part of the bead is off, exposing the copper (ferrule) it is very difficult to get a good weld.

"Our first experience on flue welding was tried out on a Pacific type engine. This engine was shopped for a new back flue sheet. The old sheet was so badly worn and buckled that it was impossible to keep flues tight. We had just installed our electric welding plant and we were anxious to see what could be done along this line. Flue beads and sheets were thoroughly cleaned with sand blast, given a light working and welded in. After thirteen months' service, up to the date of making the report, there has been no trouble by leaking. During this period

of time hydrostatic test was applied and no leaks developed. This job was done at a cost of \$14.68, where a new flue sheet would cost about \$150, and the engine held out of service at least 30 days."

The report was made by a member of the association and shows the results of the work that is being done in our part of the country.

Practices, of course, vary in regard to the best method of welding flues. Generally the flues are applied in the usual manner with copper ferrules and rolled, beaded and pressed. The bead is then welded to the flue sheet, leaving a fairly rough finish. The time of welding flues will average about 15 per hour, although

as many as 25 per hour has been accomplished. This refers to 2-inch flues. The common 5-inch superheater flues take about four times as long, and while it must be admitted that flue welding has not been entirely satisfactory in every case, it is generally believed that the difficulties which have been experienced have had their origin in the methods used and not to the process itself, and these troubles from all accounts are diminishing with increasing experience. As stated at the outset, it is false economy under any condition to apply new means and new methods to worn out parts out of boilers, just as it was said of old that it is useless to put new patches on old garments.

**Pneumatically Operated Drill Press Clamp.**

By J. H. HAIN, Long Beach, Miss.

The accompanying sketch illustrates the method of applying a pneumatic clamp to any drill press. In most shops there are generally one or more drill presses on which all small work, such as clamps and braces of all sizes, are drilled, some requiring a certain amount of clamping. This, of course, takes time.

The pneumatic clamp illustrated was designed to save time in clamping small jobs and is easily attached to any style of drill press. No dimensions are given as local conditions will govern the installation of this device. The cylinder can be made to suit the particular drill press, taking into consideration the power required and class of work. A cylinder of from 4 in. to 6 in. in diameter with the average shop pressure should develop sufficient power. If shop pressure is too high put a reducing valve in the line. The cylinder can be inverted and arrangement of levers changed to suit. The clamp C has extra holes to facilitate reaching any part of the work. The air is admitted to the cylinder and exhausted by the use of two cut-out cocks, "A" and "B," and the sketch illustrates the other important features clearly. This device will save time and is an aid to "safety always."

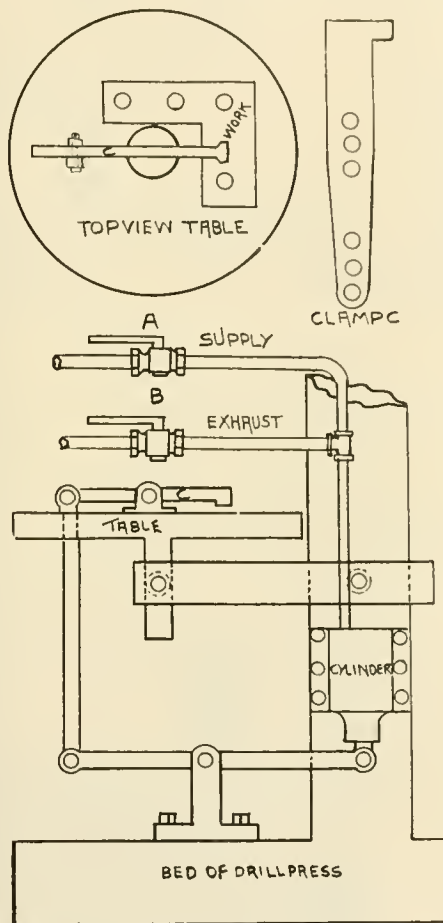

DETAILS OF PNEUMATICALLY OPERATED DRILL PRESS.

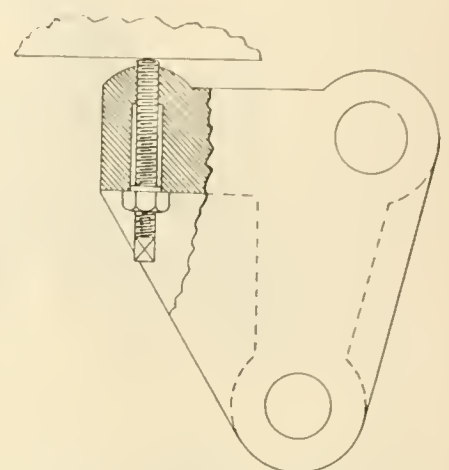

REPAIRS ON DOUBLE LEAF BASCULE BRIDGE.

and the same time may keep the center chords in line.

**Heat Losses Due to Scale.**

In regard to heat losses due to scale, we may state in answer to a correspondent that while authorities differ very much on the subject the following may be taken as very reliable information from one of the highest authorities with which we are acquainted.

The Engineering Department of the University of Illinois some time ago made exhaustive experiments to ascertain the effect of scale on the transmission of heat through boiler tubes. The conclusions from the tests are summarized as follows:

That for scale of thicknesses up to 1/8 inch the heat loss may vary in individual cases from insignificant amounts to as much as 12 per cent. That heat losses increase with thickness is an undetermined ratio. That the mechanical structure of the scale is of much more importance than thickness in producing the loss, and that chemical composition, except in so far as it affects the structure of the scale, has no direct influence on heat transmission.

**Repair of Double Leaf Bascule Bridge.**

By J. G. KOPPEL, S. Ste. M. Br. Co.

During the operation of the double-leaf bascule bridge at Soo, Mich., it was found that the center chords did not line up properly by each closing the bridge. The chords instead to come in line, they lined one a little lower than the other, which interfered to close the chord safety lock. Furthermore, it was found that between the lineup castings, one on each side, a clearance of five-sixteenths of an inch, and by closing when

the south leaf engage the north leaf to bring down both leaves to the closed position, but the south leaf on which the castings are mounted, due to the clearance, came a little too low, and the results were that the rails and the top chords were out of line.

This difficulty was solved by drilling a hole right through that lineup casting, and tapped to receive a set-screw like adjustable bumper head, as shown on the accompanying illustration, which are adjustable in accordance with the wear

# Important Details in Adjusting the Walschaerts and Baker Valve Gears

By E. C. GOETZE, Portsmouth, Ohio

There are many things to keep in mind in setting valves on locomotives equipped with the Baker gear or Walschaerts gear. In making repairs that all parts should be checked and placed in position as shown on the blue prints.

radius bar hanger on Walschaerts gear. If the total travel is found to be greater than required amount, change by moving the stops toward center of the quadrant, or if travel is found to be less than required amount add notches to quadrant.

moved toward center of driving axle until tram point is in middle of the two points on guide. If mark made by tram when engine is on forward center is back of one made when engine is on backward center, eccentric should be

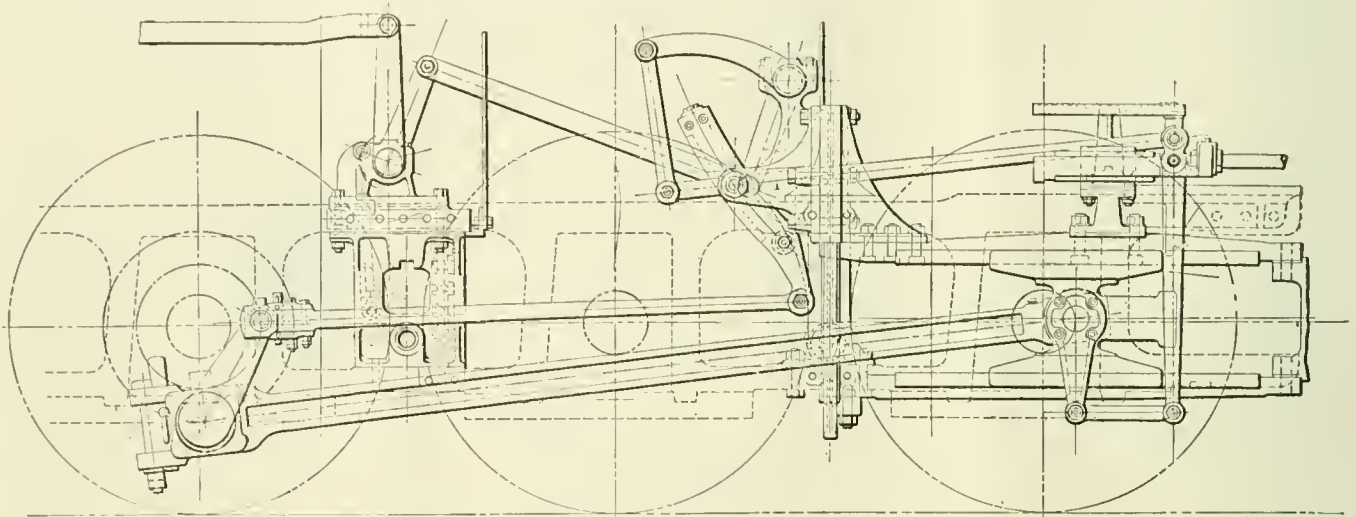

WALSCHAERTS VALVE GEAR APPLIED TO LOCOMOTIVE.

The locomotive should be leveled and the saddle on main driving box should be blocked upon frame the distance, about what the engine would settle when in service, the rollers should be placed under the main wheels and should be adjusted so that the main driving boxes are up against the spring saddle so the tension will hold main journal in place in driving boxes.

The reverse bar should be put into the next to last notch in forward motion (this extra notch to allow for the expansion) the wheels should be rolled forward to get the full travel of the valves and also to get crosshead travel. The main rod should be corrected to proper length, then place reverse bar in the last notch in back up position, then roll wheel backward, get full travel of valves and prove travel of the crosshead (this to be used when proving cut-off). Combine the forward and backward travel on each side and if found to be the correct amount, this would indicate that the quadrant is correct.

If too much travel is shown in forward motion and not enough in back-up motion, this change should be made by shortening the long reach rod to suit, or vice versa; or should one side be shorter than the opposite side, this should be corrected by changing the short reach rod on a Baker valve gear, and by changing

When corrections have been made, place reverse bar in center of the quadrant thus placing the valve gear neutral; roll wheels forward, marking travel of the valve on the valve rod (this travel indicates constant lead and lap of valve). While getting this travel the dead center

moved from center of driving axle until tram point is in middle of two points on guide. The openings of valve should now be taken and checked with the lead and lap travel and if found out of center, valve stem should be corrected, making lead equal on each end. Place reverse

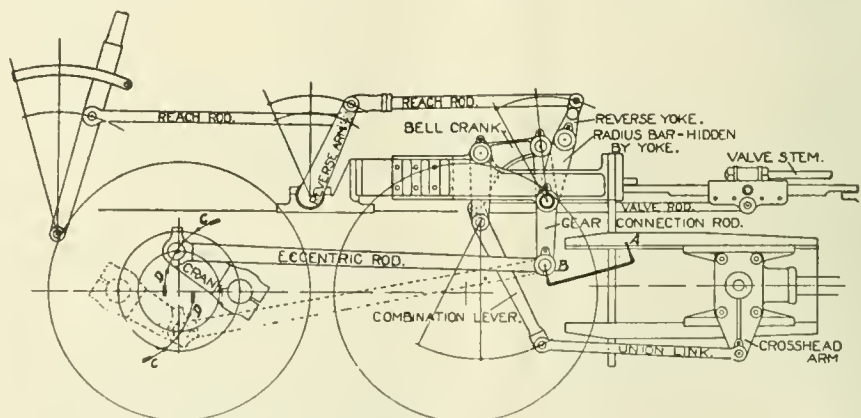

BAKER VALVE GEAR.

should be taken. On each dead center a tram should be placed in the center of eccentric rod bolt at links and a mark made on guide, if the mark made by tram when engine is on forward center is ahead of one made when engine is on backward center, the eccentric should be

bar in next to last notch in quadrant in forward motion, roll wheels forward and catch each dead center, marking the valve stem, place reverse bar in last notch in backward motion, catch each dead center, marking the valve stem, change eccentric rod to divide marks made on valve stem.

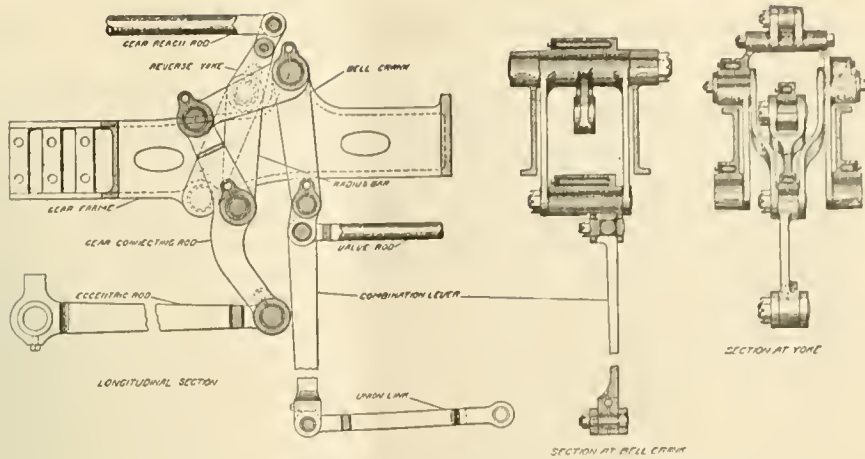

DETAILS OF BAKER VALVE GEAR—INSIDE ADMISSION.

The ratio of change on Baker gear is 4 to 1; on Walschaerts gear ratio is (valve travel divided into diameter of circle of eccentric; example, Valve travel is 6 inches, diameter 18 inches, Ratio 3 to 1) 3 to 1.

Prove engine by catching on each center in both directions. Place reverse bar in 10th notch of quadrant in forward motion, roll wheels forward. When tram points are on line of valve opening, stop rolling and measure distance between cross-head and travel, mark on guide, marking this distance down some convenient place, doing this on all points of both forward and backward motion. If forward motion on right side totals 36 inches (that is if back end is 19 inches and front end 17 inches) and left side totals 34 inches, this should be corrected by lengthening the short reach rod on

Baker gear, or by lengthening radius bar hanger on Walschaerts gear on left side or by shortening short reach rod on Baker gear and shortening radius bar on Walschaerts gear.

As before stated, the back end is 19 inches and front 17 inches, corrections should be made by lengthening eccentric rod (mark valve stem and guide at cross-head, then move crosshead 1 inch and mark valve stem; if found that valve stem has moved 1/16 inch to the cross-head's 1 inch, this will be the proper ratio), 1/4 inch on Baker gear and 3/16 inch on Walschaerts. If front end is 19 inches and back 17 inches corrections should be made by shortening rod 1/4 inch in Baker and 3/16 inch in Walschaerts gear.

This article refers to locomotives having inside steam admittance.

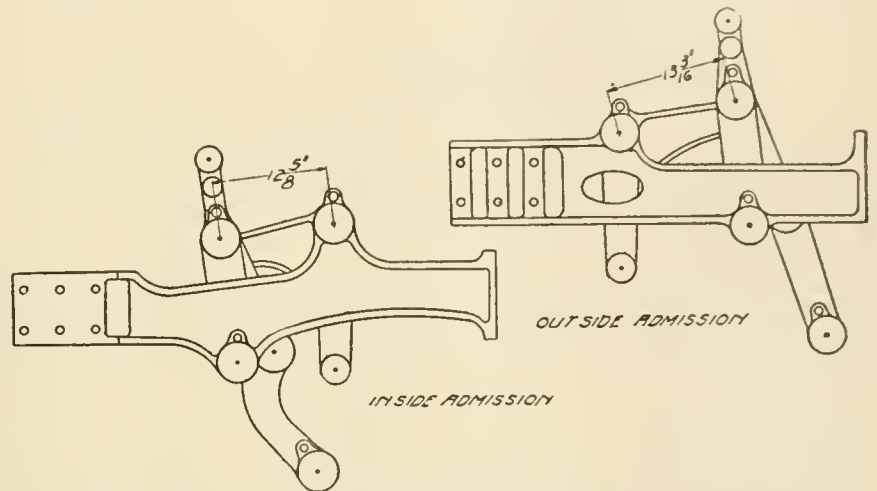

BAKER VALVE GEAR DETAILS—OUTSIDE AND INSIDE ADMISSION.

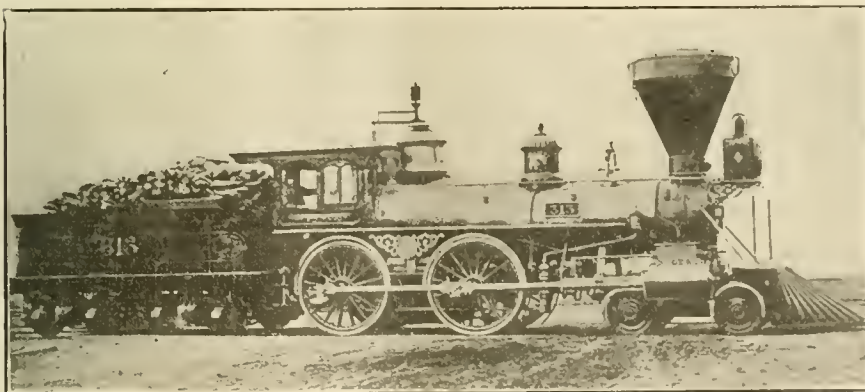

**Another Old-Time Erie Flyer.**

BY ANDREW J. FALLON, SPARKHILL, N. Y.  
 Locomotive No. 313, as shown in the accompanying illustration, was built at the Rogers Locomotive Works, Paterson, N. J., fifty years ago. It was one of the finest types of the highly decorated engines that came into favor in the sixties. Burnished brass and fine scroll work contributed to make these early engines the wonder and admiration of the country people. It was as good as a circus. Farmers with feet like frying pans and

whiskers like weeping willows would gaze in dumb wonderment at the shining spectacle. The glitter of it all had a reconciling effect on the stupid creatures who opposed the introduction of railways, just as the tinsel trappings of kings and queens have a soothing effect on the muddled mind of the average modern European. As soon as the railroads became popular, on account of their utility to meet a growing necessity, the glitter of gold that was not even skin deep, and the sheen of silver that was only German

at the best, vanished in the scrap heap, and the improved locomotives, panoplied only in their supreme strength, came forth to bring the far ends of the continents together. As it was, these gilded giants of their day could run some. The No. 313 referred to ran between Jersey City and Middletown at a speed that has not been excelled in our day. The locomotive was run for many years by Ben Haffner, known as the "Flying Dutchman." The train was known as the Orange County Flyer, the crack train of the road for nearly twenty years. When behind time for any unforeseen cause the "Flying Dutchman" refused to stop at the local stations. Its records were the cause of much comment among railroad officials, and Ben Haffner was a big man in his day, or at least they thought he was. He maintained his reputation by refusing to touch any other locomotive during the periods when the No. 313 was undergoing repairs. Ben assumed a kind of super-luminary authority over the progress of the repairs. What he did not know he pretended to know, like many other big railway men in those days and also in our own time.

# Construction, Maintenance and Abuse of Freight Cars

At a recent meeting of the Car Foremen's Association of Chicago, Ill., a very interesting paper was read by Mr. C. J. Wymer, general car foreman of the Belt Railway, on the subject of Freight Car Construction, Maintenance and Abuse, from which we quote the following pertinent observations:

The railroads expend annually large sums of money in purchasing new equipment of many designs, according to the use to be made of it and the individual opinion of those invested with the authority to make a final decision. These investments are made for the single purpose of providing a suitable number and quality of vehicles to meet the requirements of the railroads in successfully transporting commodities incident to the commercial and agricultural pursuits of the citizenry. If the vehicles provided fail to perform this function in an efficient manner they have not measured up to the fullest intent of their purposes. There are several important features to keep in mind in designing new equipment in order to combine economy and efficiency in such a way as to utilize the money expended with the best possible result. It is desirable to use the minimum amount of material possible, without sacrificing efficiency, as an unnecessary pound of metal or foot of lumber here and there not only adds to the initial cost and subsequent maintenance but adds to the cost of transporting the vehicle as each pound of weight contributes its proportion to this expense in the way of fuel consumption, wear on locomotives, tracks, and the vehicle itself and when considered individually is comparatively small, but when several hundred pounds are multiplied by a great number of cars and again by several years of life, it assumes proportions of large dimensions and worthy of recognition. While this is an economy deserving of careful consideration there is also a danger in employing its use to the extent that it ceases to be an economy only so far as the initial cost is concerned, and proves a burden of expense in future maintenance, accidents, delays, loss and damage to freight, etc., which more than offset the first advantage gained. Observation demonstrates that this condition not unfrequently exists either from an over zealous desire to reduce initial cost or lack of definite knowledge of requirements.

Of the two evils mentioned above the latter is more readily recognized, as it is prominently brought to the surface through failures, while the other is distributed over a long life of existence and is discovered only through technical investigation. In our opinion a reasonable factor of safety should be included in the design in excess of technical requirements to provide a resistance necessary to equal-

ize, in a measure, against an unjust service due to the human element which, while undesirable, nevertheless exists regardless of any discipline administered, and in many cases is excusable.

A proper assemblage of parts is also a feature to be kept prominently in mind when designing new cars in order to obtain strength where the greatest resistance is required, and not to exceed requirements where resistance is not such an important factor, and simplicity of renewal when repairs are necessary. Some cars are apparently designed with the thought that it is a permanent structure and the parts will endure throughout the life of the car without attention or the builder has failed to give any thought to future maintenance. If the structure would endure without future repairs, it would be an ideal condition, but failures due to deterioration and accident comes into the life of all cars, and when simplicity of assemblage, without sacrifice of efficiency, has not been given due consideration, it is certain that unnecessary expense is added to the future maintenance.

The use of commercial sizes and shapes is another thought to keep in mind in the designing of new cars as their use lowers the cost of repairs, as well as detention of cars during their life.

Periodically reducing and reorganizing forces adds very much to prevent economical repairs. Each time a shop is organized for extensive repairs it means the introduction of a large percentage of new labor, taking time to become efficient, and the money thus expended would keep a well organized force of efficient help permanently employed, producing a larger volume of work. If of necessity the forces are to be larger at certain times than others, the greatest result to be obtained, for money expended, can be accomplished by doing so at seasons of the year when weather conditions are most favorable, as there is a considerable percentage of loss in labor performed when there is no protection from the elements during the winter season in climates so affected.

It is also a good business proposition to exert energies in repairing cars and getting them in serviceable condition when they are idle and not needed in service, having them in condition to earn revenue when in demand, instead of having them idle or in service in a crippled condition. Good serviceable cars mean so much in reducing other expenses resulting from cars in poor condition that there seems to be no good reason why they should not be maintained in an efficient serviceable condition. A load placed in a defective car most generally means delayed movement, added expense in transporting, claims for damage, and often dissatisfied customers.

An accident resulting from a bad car often means damage and destruction to other good cars, delay to the entire traffic of the railroad, added expense to the M. of E. account and M. of W. account, for frequently serious track damage results in addition to damaged equipment.

There is also a vast army of men employed by the railroads whose principal duty is to make records as a means of protection against so-called delivering line defects, and attach greater importance to some sheathing slightly raked, that may not affect the service of the car, than they do to a worn wheel or numerous other defects, endangering the safety of the equipment, commodity, and human life. We lay no censure at the doors of the men who are performing this service as we are constantly educating them, that it is almost a crime to overlook a defect involving a defect card which often has a value of less than a dollar. Why not take a business-like view of the situation and cease spending two dollars in an effort to save one. Do away with the delivering line defects, inspect for safety of operation and commodity only, educate these men along the lines of endeavor which have a real value and cease to follow illusions. A vast amount of this labor expense could be diverted to purchasing material and repairing defects which are a menace to safety instead of finding and making a record of a lot of immaterial defects at the expense of more important ones. The reduction in expense would continue down through the offices and result in saving a large labor and stationery expense there.

Another abuse which is common and in our opinion inexcusable in the great majority of cases is the use of 100 per cent. box cars for lading such as hides, coal, oil, etc., which reduces them to an unfit condition for loading grain, food products and other commodities which properly require cleanliness and protection from the elements while the car which should have been so used is set for loading the higher grade of commodity.

Cars are abused by the railroads and shippers through disregard of the loading rules which experience have found essential for proper protection to cars and commodity. It is not uncommon to see ends of cars seriously damaged through ordinary handling, because proper methods of loading have not been followed and frequently necessary to damage equipment at point of unloading for the same cause.

We believe that a careful study of effects and causes by those in authority to regulate would result in changes of many present methods which can be improved upon to the end that the condition of freight equipment would be greatly improved, resources conserved and a more satisfied public.

# The Standard Lettering of Freight Cars

Among other regulations submitted and approved at the convention of the Master Car Builders' Association held last June that of the standard lettering of freight cars received particular attention. The matter had been discussed ten years ago and some progress was made in regard to the style of letters, so that an approach to uniformity was established, and while these regulations were generally followed, no particular location on the car for the markings had been specified. Later further progress was made in recommending

markings on the various roads, and aided much in the avoidance of markings that had been common to various roads, as repetitions had become unavoidable in the initials of the vast number of railroads in North America.

The Railway Association and Master Car Builders' Association have now, however, gone a step further, and in the annual report of the latter association have issued specific directions as to the exact markings and location of the same on all kinds of freight cars.

This is as it should be, and it is a matter of surprise that some standard regulation in regard to this matter had not been adopted before, and is another proof, if proof were needed, that these associations have more work on their hands, especially in the important matter of standardization of details than can be imagined by those who do not have time or opportunities to give attention to the details of the work to which the members are giving the best consideration which their time and experience can afford.

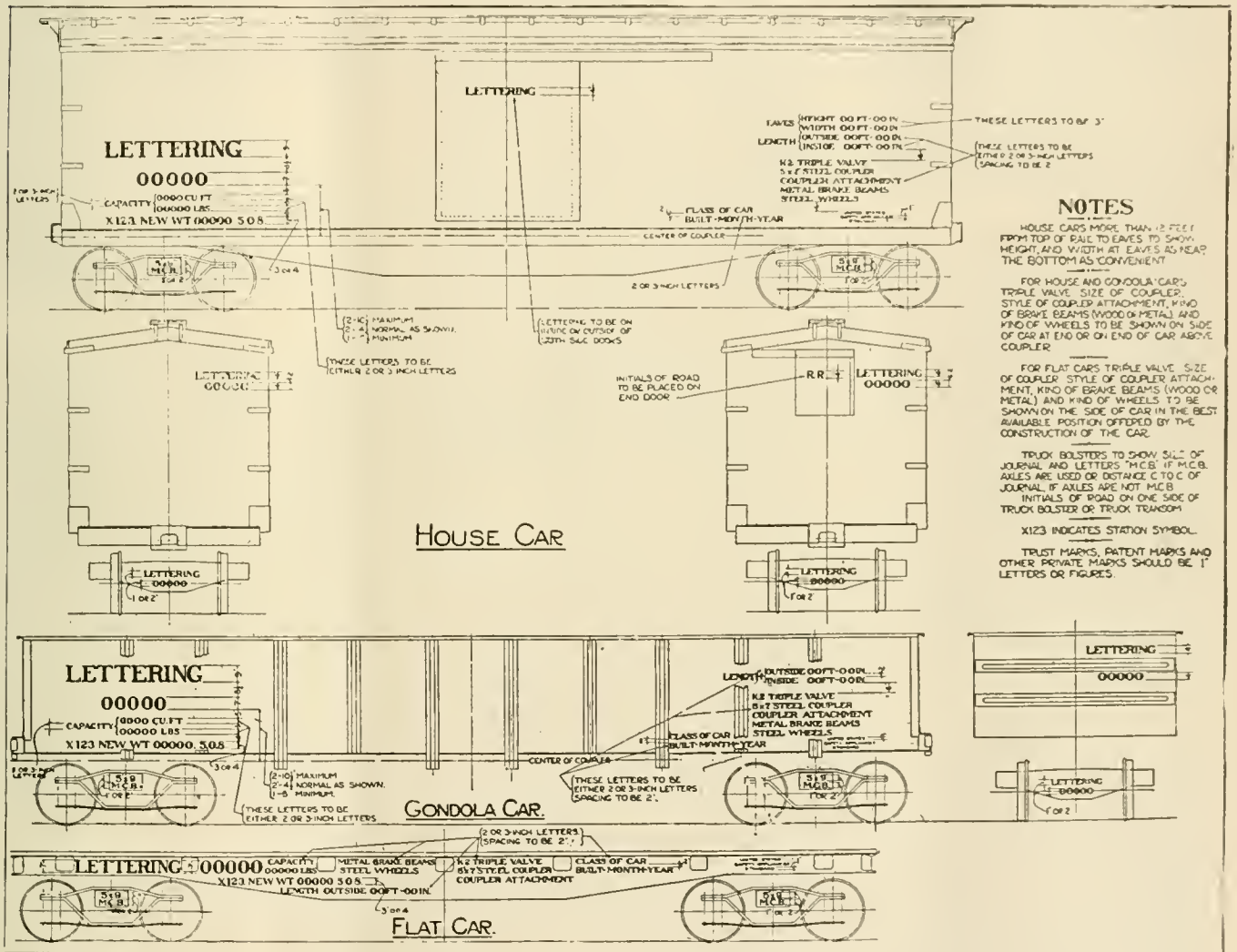

RAILWAY ASSOCIATION AND MASTER CAR BUILDERS' STANDARD LETTERING OF FREIGHT CARS.

that the markings be placed on the sides of the cars, and the markings should embrace the initials or name of the road, the number of the car, the capacity and light weight. It was also recommended that these markings be placed as nearly over the truck as possible, and that a preference be given to having the markings on the left side of the car.

The American Railway Association took up the matter three or four years ago, and after collecting data on the subject issued circulars explanatory of the

We reproduce the accompanying illustration from the report, showing the details of the approved markings on a house car, gondola car, and flat car. It will also be noted that the sizes of the various markings and letterings are specified, and it may be taken for granted that the regulations will be followed as rapidly as is convenient in cases where there is any particular variation from the standard adopted, and that all new cars will be marked strictly to conform to the standard regulations.

In this connection it may be confidently stated that there is not a single detail in connection with the mechanical appliances used on railroads, but has been reported upon from time to time by the committees of these associations, and were it not for the fact that the growing necessities of heavier and more rapid transportation to meet modern demands, calls into being newer and more convenient devices, which call for concerted action and regulation, it otherwise might be said that their work had been accomplished.

## Department of Questions and Answers

### OFFSET ROCKER.

M. D. Mehl, Chicago, Ill., asks: In some locomotives as a part of the valve gear a transmission bar is used, and the arm to which the bar is connected is not exactly plumb with the arm to which the valve rod is attached. How is this variation accounted for? A. It is not always possible that the transmission bar could be placed so as to be exactly in the same plane as the engine frames, and in order to make up for the angularity of the bar the rocker arm is offset a certain amount to make up for the deficiency caused by the angle of inclination. The amount of offset may be readily found by describing an arc, the radius of which is the length of the transmission bar, then lines drawn in the perfect plane bisecting the two connecting points will show the amount of variation where the lines cross the arc referred to.

### LEAKY FLUES IN OIL BURNING LOCOMOTIVES.

G. M. N., Flagstaff, Ariz., writes: I am running an oil burning engine with front end burner and with the draft placed under the burner in the front end. We have experienced some trouble with the tubes leaking. Would it be better to have the draft in the back end of the fire-box? Would it help the tubes? Any information will be appreciated here.

A.—Much depends upon the construction of the brick arch. In any form the flame should be thrown against the back of the crown sheet so that the entire heating surface is swept by the flame before reaching the flues. Much also depends on the working of the appliance. When the throttle is closed and the fire being cut down, great care must be exercised or the fire will be put entirely out, and this is very hard on the fire-boxes and flue ends. Going into stations where stops are to be made, the sheets are expanded with the intense heat, and the fireman not infrequently puts the fire entirely out. This is wrong. The placing of the burner on the front of the fire-box should be an advantage in the saving of the flues, but no amount of precaution can prevent leaky flues in a worn-out flue sheet, especially if scale has been allowed to accumulated around the flues.

### POSITION OF LINK BLOCK.

H. A. S., Bordentown, N. J., asks: Why do the Pennsylvania railroad locomotives on some types of locomotives have the valve gear so adjusted that the link block is on the top of the link when the reverse lever is in the forward gear, whereas in the forward gear on the H 6 B. S. type it is just the opposite? A.

The various types of locomotives first referred to are equipped with what is known as the Stephenson or shifting link, and the latter with the Walschaerts or stationery link. In the former the link is slidably engaged on the link block and moves upwards or downwards on the stationery block, whereas on the latter the block moves in the link, the link being pivoted on a stationary block.

### OUTSIDE AND INSIDE ADMISSION VALVES.

G. E. Q., Youngstown, Ohio, asks: Why is it that an outside admission valve is generally used on low pressure cylinders of Mallet compounds with both piston and slide valve type? A. It will be readily understood that in the case of the low pressure steam chamber the ordinary slide valve being much more easily balanced is more adaptable to the service, being less costly in construction and less apt to get out of order. There is undoubtedly some loss in the balancing of the slide valve, but it is more than made up in economical construction and maintenance at low pressures. The advantage of an inside admission valve over that of an outside admission is not particularly apparent, but is sometimes convenient in regard to the construction of the exhaust cavities. Inside admission is only used where piston valves are employed.

### LOCATION OF LOCOMOTIVE CYLINDERS.

M. D. McD., Chicago, Ill., asks: Would better results not be obtained in a locomotive if the cylinders were set central to the main driving axle instead of from four to six inches above the center? A. Yes, as far as the wear of rails and wheel tires are concerned, and such is the practice on all modern locomotives except in rare instances where some particular design a location of truck makes it necessary to elevate the cylinders above the plane of the driving axles. Many of the early locomotives had the cylinders set a considerable distance above the running center, a delusion existing that it added to the adhesive quality of the engine. This theory was long ago exploded.

### POWER TO MOVE AND STOP A CAR.

J. G. A., Binghamton, N. Y., asks: (1) About how much power per ton does it require to start a car from a state of perfect rest? (2) Would an invention that utilizes for starting the power absorbed on stopping a car be a new and useful invention? A.—(1) From ten to sixteen pounds per ton. (2) No. It would neither be new nor useful. It has been tried often and has been proved to be utterly impracticable.

### COAL OR OIL FUEL FOR LOCOMOTIVES.

S. G., Pensacola, Fla., asks: What are the advantages, if any, in the use of oil fuel in comparison with the use of coal in firing locomotives? Reports are furnished that the difference is 1.75 to 1 in favor of oil fuel, all things being considered. What information have you on the subject? A. Our best information is that if there be any advantage it is in favor of oil, but the matter depends entirely on the locality. Oil fuel is not being used to any extent where the supply of coal is plentiful and consequently cheap, and the same condition affects the regions where oil is plentiful and coal undiscovered, so that the districts may be said to regulate themselves, and are not subject to any general law from which an exact comparison might be drawn. Some advantages in the use of oil fuel are undeniable. It is more nearly under perfect control. There is a saving in labor, and an absence of ashes and cinders which are advantages of considerable merit.

### MUD RING LEAKING.

W. R. G., Edmonton, Alberta, writes: I have noticed that the mud ring leaked much more during the winter than in other seasons. Our boilers are washed out regularly. How is the variation accounted for? A.—Many of the lesser leaks on locomotive boilers are caused by variations in temperature, which causes extreme contraction and expansion. The thin boiler sheets contract much more rapidly in extreme cold weather than the mud ring, which is of considerable thickness. Hence the tendency to leak around the mud ring is much greater in winter than in summer. The locomotives are subjected to harder usage all round in winter than in summer.

### DISTRIBUTING VALVE WORKS IN QUICK-ACTION.

E. B. M., Gordonsville, Va., writes: What are the principal causes of the distributing valve on a locomotive working in quick-action when a service application is intended? A.—From your former questions we assume that you are acquainted with the various defects of the brake apparatus which results in the disorder, and when none of these defects are apparent, the lubricant used or the moisture accumulating about the equalizing valve of the distributing valve is responsible for the undesired action. This trouble will likely occur at different times in the year so long as operating valves are fitted with brake pipe venting devices or so long as the rate of brake pipe reduction that produces service op-



eration and that which must produce quick-action are not any farther apart than that required by the Master Car Builders; but the writer's practice in stopping this disorder in a distributing valve was to merely remove the equalizing piston and slide valve of the distributing valve and wipe it perfectly dry and replace it, assuming that no mechanical defect was found. From a considerable number of experiments with distributing valves, various types of triple valves, control valves and universal valves, the writer feels free to say that while the operating valves are maintained perfectly dry, whether lubricated with dry graphite, or not lubricated with anything but that contained in the atmosphere itself, the chances of undesired quick-action are at the minimum; but so long as oil or moisture accumulates on the slide valves or pistons undesired quick-action may be expected.

#### PASSENGER CAR BRAKE CYLINDER ARRANGEMENT.

R. P., Richmond, Va., writes: I have recently seen a passenger car equipped with the P. C. brake equipment, of which one brake cylinder was 18 in. and the other 16 in. Can you tell me why this is, as I was always under the impression that both cylinders of the P. C. brake were supposed to be of the same size? A.—The object of using the smaller cylinder for emergency operation is to reduce the emergency braking ratio developed. When such brake equipments are correctly installed, the service braking ratio is 90 per cent. based on a 24 lb. drop in the auxiliary reservoir, and with both cylinders in operation, the braking ratio for emergencies would be 180 per cent. when the cylinders are of the same size; but this is considered to be pretty high as compared with the P. M. brake, and as these cars are operated among P. M. equipment, the use of a smaller emergency cylinder does not double the braking ratio, so that the 16 in. cylinder gives about 160 per cent. instead of 180 per cent. braking ratio for emergency stops, which is about equal to that developed by the L. N. brake, and thus a car with P. C. equipment can be operated among P. M. equipment, and will produce no greater deviations from standards of uniformity than a car equipped with the L. N. brake.

#### CAUSES FOR UNDESIRED QUICK-ACTION.

E. B. M., Gordonsville, Va., writes: What are the most common causes for undesired quick-action in passenger train service at the present time? A.—Undesired quick-action of course results from some defect of the brake equipment, and there are about 45 disorders that may in some manner contribute to it, but from your question the causes of the particular cases you have in mind have not been

discovered, therefore the disorder must be or have been occasional and they are exceedingly difficult to locate positively. The reason that the cause of the occasional undesired quick-action is so difficult to locate is that the application when it occurs, in itself removes the cause of the disorder; as an example a triple valve slide valve may be what is termed "water packed," and as the application occurs the moisture may be blown away from the slide valve or the "packing" or seal about the slide valve may be broken and thereafter the trouble may not recur, hence about the only way the cause of such a disorder may be definitely located and remedied is to make an examination of every operating valve in the train and the entire equipment of the locomotive immediately after the disorder is manifested.

While in some cases the disorder may be due to a high temperature of the compressed air in the brake pipe resulting from an overheated compressor the chief cause, assuming that there are no visible mechanical defects, is the quality and quantity of the lubricant used on the triple valves or operating valves on the cars and in the distributing valve of the locomotive.

#### FIT OF TRIPLE VALVE PISTON.

J. M. C., Dayton, O., writes: (1) How close should a triple valve piston fit in the piston bushing? (2) How much beyond the standard size should a bushing be permitted to enlarge before the valve should be rebushed? A.—(1) This is largely a matter of opinion among air brake men, but under modern air brake conditions, the piston should at all times be a neat fit in the piston bushing, or as an example, the triple valve piston should be as neatly fitted as the equalizing piston in the H-6 brake valve. You are no doubt aware of the difference in leakage past the equalizing piston as a result of the difference in the fit of the piston in this valve and in the G-6 valve, and the same reduction in leakage is desirable in triple valve operation in long trains. (2) The Westinghouse Air Brake Company's practice is to rebush a triple valve when the piston bushing is worn .008 inch or more, or if truing up the bushing will enlarge it beyond this figure, but if the fit of the triple valve piston is to be maintained there must be no scraping, reaming or rolling of bushings unless a larger than standard piston is to be used, and this would be impracticable and unnecessary, as a maintenance of a fit of these parts, while expensive from one point of view, will be more than offset by the reduction in the cost of stuck brakes, slid flat wheels and break-in-two-of trains.

#### UNDESIRED QUICK-ACTION.

E. B. M., Gordonsville, Va., writes: Is it possible for the brake pipe air to flow through the service exhaust port of

the H-6 brake valve fast enough to cause the brakes to work in quick-action? A.—It is and it is not. If the brake valve and its connections are in first class condition, the rate of reduction through the brake pipe service exhaust port cannot be rapid enough in itself to cause undesired quick-action, but if the equalizing discharge valve of the brake valve is what is termed "sticky," or if the ring is too tight in the bushing or if the preliminary exhaust port is enlarged, if the equalizing reservoir volume is reduced from the water in the reservoir, or if there happens to be a restriction in the equalizing reservoir piping, or if the brake pipe exhaust is enlarged considerably beyond  $\frac{1}{4}$  of an inch in the opening, the reduction in service position may be at a rate rapid enough to cause the disorder mentioned.

#### GRADUATED RELEASE OF L. TRIPLE VALVE.

R. P., Richmond, Va., writes: We recently had an L-3 triple valve with which the pressure could not be graduated out of the brake cylinder with the supplementary reservoir cut in and every part of the triple valve apparently in first class condition. Could you tell me what could cause a triple valve to fail to graduate the release under such conditions? A.—The triple valve was likely one in which the graduated release feature had been eliminated by drilling a hole through the slide valve bridge between the port leading from the brake cylinder and the port leading to the exhaust. Quite a large number of these valves are in service; the object was to retain the high emergency brake cylinder pressure but to eliminate the graduated release, while the majority of the cars in the train were equipped with type P triple valves.

#### Screwdriver.

The advantage that a long screwdriver has over a short one is, that the former allows more play in the hand, and makes a less angle with the perpendicular of the screw than a smaller one with the same amount of play, and therefore the blade is less liable to leave the screw. If both kept their place equally well, the actual amount of force exerted would be the same in both; but since the larger one keeps in the notch better than the shorter one, it therefore drives a screw in with less trouble. A round handle is better than a flat one.

#### Speed of Steam.

Allowing the area of the steam ports to be about one-twentieth of the area of the cylinder, and the piston moving at about 300 feet per minute, steam would travel through the ports at nearly its maximum velocity of 6,000 feet per minute. The ports should be arranged to suit this speed.

# Railway & Locomotive Engineering

A Practical Journal of Motive Power, Rolling Stock and Appliances.

Published Monthly by

## ANGUS SINCLAIR CO.

114 Liberty St., New York.

Telephone, 746 Rector.

Cable Address, "Locong," N. Y.  
Glasgow, "Loconauto."

### Business Department:

ANGUS SINCLAIR, D. E., Prest. and Treas.  
JAMES KENNEDY, Vice-Prest.  
HARRY A. KENNEY, Secy. and Gen. Mgr.

### Editorial Department:

ANGUS SINCLAIR, D. E., Editor.  
JAMES KENNEDY, Managing Editor.  
GEO. W. KIEHM, Associate Editor.

### London Representative:

THE LOCOMOTIVE PUBLISHING CO., Ltd.,  
3 Amen Corner, Paternoster Row, London, E. C.

### Glasgow Representative:

A. F. SINCLAIR, 15 Manor Road, Bellabouston,  
Glasgow.

### SUBSCRIPTION PRICE

\$2.00 per year, \$1.00 for six months, postage paid in the United States, Canada and Mexico. For other parts of the world, \$2.50, or ten shillings. Single copies, 20 cents. Remit by Express Money Order, Draft, Post Office Order or Registered Letter.

Mailing address can be changed as often as necessary—always give old and new address, and if you subscribe in a club, state the name of the agent.

Please give prompt notice when your paper fails to reach you regularly.

Entered at the Post Office, New York, as Second-class Mail Matter.

### Progressive Enginemen.

The American Railway Master Mechanics Association, the Traveling Engineers Association and other organizations have been discussing the subject of education of enginemen, but we do not yet find that theme so threadbare that our readers would be inflicted by an article on the subject.

Locomotive enginemen having ambition to rise in the railway world should have a good common school education. He should be a passable reader; he should understand orthography and be exempt from frequent blunders in reading; he should know enough of English grammar to write the language approximately correct. He should understand arithmetic, and if he is commendably ambitious he will master such studies; indeed, if he is aspiring, eager for superiority and distinc-

tion he will do more than we have suggested. He will learn to get a thorough knowledge of one's business, acquire skill in one's vocation, more accurately expresses our ideas than the term "education."

We say "learn a trade" and "study a profession." We say master mechanic and master car builder, why not use the term master fireman? It would involve far more knowledge than how to break coal and shovel it into a fire-box. It would mean that the master fireman had husbanded his resources and utilized his opportunities in learning everything pertaining to his chosen calling. It would mean that his leisure hours had been devoted to study, to investigation of reasons why, and it would mean that the master mechanic had set his seal of approval upon his habits of study and sifting research and had marked him for promotion.

As a general proposition the men who start in to fire locomotives are not proficient in common school learning; they are lacking in reading, writing and arithmetic. In saying this we do not assume that the young men are entirely responsible for their deficiencies. Their opportunities have been limited, their surroundings unfavorable for self help; the necessities of their situation such that their ambition was not excited; their associations may not have been of a character to awaken ambition for knowledge; their mental development did not keep pace with the physical growth, and when forced to enter the army of workers, their educational equipment was defective. We do not, therefore, hold illiterate firemen entirely responsible for their inadequate attainment. They are mostly busy fellows, generous hearted, strong of body and will, as thousands of them, ambitious to advance in the calling that has come to their hands. Here the question arises: What will specially contribute to their success?

The great organization of locomotive enginemen insists upon good moral character as a prerequisite, soundness of body and mind, fidelity to obligation, honorable dealing with associates and with all men. In a word, the ethical requirements in such matters are strictly and unbindingly orthodox, and any member of the organization mentioned who violates the constitution and laws designed to keep the order morally healthy and upright are summarily dropped.

The locomotive engineman has become by universal admission, one of the important factors in the railway enterprises of the country, than which not one is more conspicuous. The eyes of the nation are fixed upon him with an earnestness that attaches to no other class of wage-earners. If, therefore, he is to respond to reasonable expectations, he must be educationally equipped, and since such opportunity of preparation is within his reach, excuses will not be tolerated.

As has always been the case, the locomotive firemen of today are to become the locomotive engineers of the future with duties of increasing responsibility. When that goal is reached, it will not be the *ultima thule* of many men's ambition, especially of those who have educated themselves for moving upwards. There are many higher positions in railway service which the trained locomotive engineer may aspire to fill better than any other class of railway employes. His training is of the character that makes men self-reliant, clear sighted and familiar with the process of overcoming difficulties. The proportion of enginemen who will advance to the higher ranks in the future will depend upon the advantage taken of the educational opportunities.

### Safety First.

In some respects the people of the United States are inclined to be too independent. They not only incline to be a law unto themselves, but there is a decided tendency to ignore the laws that have been framed for the benefit and safety of the whole people. This fact has frequently been forced upon our attention in connection with the criminal manner in which our laws enjoining the systematic inspection of steam boilers are ignored. All industrial countries except the United States are blessed by laws requiring the systematic inspection of every appliance used that is likely to jeopardize human life, when defective or in bad order. Mines and railway appliances, factories and steamers, engines and boilers are subject to rigid inspection by experts. Not nominal examination by interested parties, but by trained experts. Such a system greatly reduces the number of dangerous accidents, yet with the greatest care casualties of a serious nature happen occasionally in all the departments named. One of the most valuable features about the proper inspection system is, that when an accident does happen, experts are required to make a thorough investigation and the true cause of the accident is made public. Publishing of all the facts connected with railway accidents has had a powerful influence in causing railway companies to adopt the best appliances for the promotion of safety, and has stimulated the sentiment now becoming so emphatic—safety first.

It seems to us that the sentiment underlying the now popular shibboleth "Safety First" has had of late an excellent influence in the prevention of railway accidents, for we do not remember a period of the same length when serious railway accidents have been so rare as they have been during the last year, and it may be that the talk of safety first is reforming the minds of those who in the past have been

more inclined to defy the law than to obey its injunctions.

It would be a good thing for those promoting safety first to make it plain what are dangerous practices. When an accident has happened it would be well for the officials to give particulars of the cause. There is great need for the imparting to the public as well as to the railway employes exact information as to the cause of every accident that results in suffering or loss of life. Where there is so much material and mechanism subject to the severe service of heavy fast train operating, there are many links in the chain of mechanism liable to break and cause accidents, so that safety can be maintained only by constant vigilance in watching the gradually weakening of wear that ends in breakage. But by far the most common and disastrous accident to railway trains is the collision. Collisions happen because proper means are not employed to keep the trains apart. The American locomotive engineer has always been famous for the skill and vigilance that keep trains running under difficulties free from accident, but nowadays trains are becoming too numerous to be kept apart by the vigilance of the engineer. Fixed signals are becoming essential, and until more of these are installed the list of fatal train accidents are certain to increase. The official propagating the idea safety first ought to direct their sympathies to first signals as the best kind of means to promote safety.

#### High Water in Superheater Locomotives.

The difficulties encountered in the early use of the superheater as applied to locomotives have been almost entirely overcome. Many of them arose from lack of experience. Some troubles still linger from the same cause. Among these the tendency among young engineers, and others not so young, of carrying the water too high in the boiler has a pernicious effect, in many cases almost nullifying the economy of superheating. It is generally conceded that a high water engineer operating a saturated locomotive, needed a superheater to overcome the bad effects of this practice, and, of course, the superheater has the effect of helping the high water man. With a locomotive equipped with the superheater it is possible to carry water at almost any level without being able to discover its presence in the cylinders.

In the case of high water the superheater is merely an auxiliary boiler, and helps to evaporate the moisture or water carried along with the steam, thus utilizing the appliance which should be used in raising the temperature of the steam in changing the mixture of water into steam. As a matter of fact it is not

necessary to carry water so high as it is in saturated practice under certain conditions. Locomotives equipped with superheater appliances develop as much power as a saturated steam locomotive with at least 30 per cent. less water, thereby reducing the liability of the water being used with the same degree of rapidity as it does in the operation of the saturated locomotives where a larger amount of water is required.

This fact should be impressed upon the minds of the high water men, and while the subject has been commented upon occasionally no doubt the practice of carrying too much water in the boiler is being, from all accounts, remedied. It is one of those faults of over carefulness which should not be amended; it should be abolished altogether, and we would not be surprised to learn that some mechanical genius had invented a contrivance showing the height of water in the boiler during the run of a locomotive. It would be easier of construction than Hedley's coasting clocks, that show the saving of electricity on the Interborough Rapid Transit lines, when the trains are running down a grade, and for which bonuses are offered to the motormen who show the best records of economy in power, and, consequently in fuel consumption, which is so large an item of expenditure on all railways.

#### Theory and Practice.

We are frequently moved to comment upon the good-natured contempt frequently manifested by certain persons who ought to appreciate the strong points of each other where they will persist in seeing only weakness. In the practical walks of life are to be found many who express contempt for what they call the theory of the books. They seem to think that no knowledge is valuable unless it is derived from the workshop and through practical every-day experience. Presenting a text book or scientific work to such men produces very much the same effect as does the shaking of a red flag in the face of an infuriated bull.

That our scientific writers and their works should be held in such utter disdain by their practical brothers is indeed surprising to those who have given the matter only casual thought. But there are some urgent reasons for this dislike. In the first place, all so-called scientific treatises are not worthy of the name, many being empirical and full of errors. Then many of these books indulge in the pastime of rapping the practical workman over the knuckles for his lack of scientific education, until he becomes irritated and sore over the matter. To tell a skillful workman who has spent a lifetime in learning his business that he is not proficient therein, because he is not familiar with book theories, is well calculated to

incite his ire and arouse his antagonism.

Then on one side is the practical man talking contemptuously about the bookman, while on the other hand the man of science speaks derogatively about the practical workman. It is not to be inferred that the ill will described is general, but it is more common than it ought to be. It does not follow that because a man has enjoyed sufficient education to enable him to write a readable engineering book that he has sufficient knowledge of the subject to pose as an authority. Hosts of books there are, particularly in the field of mechanics, that display woeful lack of knowledge of the practical side of the subject. Every writer of a work intended for the instruction of mechanics or of manufacturers should have practical experience in the shop or factory before writing about the operations performed therein. A laboratory experience or training in a mechanical school or such institutions as colleges and universities offer is not sufficiently thorough to enable a man to act as instructor of practical men.

Knowledge is largely the result of human experience and operation. The man of science, as distinguished from the practical man, gleans his knowledge largely from the recorded experience and observation of others; while the practical man obtains his from the actual work he performs in following his calling. The student of books may learn and does learn useful facts that the unlearned workman never discovers. But the latter coming into practical contact with the actual details of his business, has the means of testing theories and proving or disproving them as they come up; but his observations must necessarily be more or less limited, while the scientist has the wide range of all recorded experience. If he be a close student he will learn the faults, the failures and the incongruities of the various theories of his art.

The actual worker in the shop is constantly running into difficulties, many of which could be avoided by the application of broader knowledge than can be obtained in the shop. Suppose the moulder in the foundry finds that his castings are continually coming out in imperfect shape, will it not be an advantage for him to learn why they are defective? If the skill or knowledge in the foundry is not adequate to solve the problem where does he go to find a remedy—to the books or to his experience? If he depends upon the latter it may take years to find a remedy, while a few hours spent on books devoted to foundry practice may furnish an immediate remedy.

The rails produced in one of our rolling mills may turn out to be deficient in strength or wearing qualities. The best practical skill in the works may be consulted to find a remedy and thousands of tons of defective metal may be run off before the proper mixture can be ob-

tained. Yet if a piece of the defective steel had been taken to the chemist he would find by analysis of the metal where-in it was defective.

Thus science in a day furnishes the information that practical observation might require months or years to discover. The scientist imparts his knowledge through books. If he deals in truths and brings out new conceptions of the art and introduces new methods or enumerates new theories which elucidate the right way to do a thing, the practical worker finds that such books contain valuable information.

#### Favors Greater Use of Interchangeable Parts.

As far as we can learn nearly every railroad in the country is suffering from scarcity of motive power. This inconvenience has been little in evidence for a few years past, but it is again upon us and very few years pass without a shortage of locomotives afflicting some roads. At these times a locomotive is from twice to ten times its ordinary value to the company. These are the times when the engine houses are certain to get filled up with engines requiring repairs that will make them miss some trips. One has a cylinder head broken, another is laid up with a broken eccentric strap which twisted the rods and called for new adjustment. A broken valve stem is holding one locomotive, and another is bound to be idle for a day or two because the drawbar of a caboose went through the front smoke-box casting. It is needless to enumerate the small disorders or breakages that are keeping other engines in shops when the transportation department is harassed with cars waiting to be moved. The delay of locomotives waiting for small repairs at times when the road is overcrowded with business is a fruitful source of disturbance and even of animosity between the operative and the mechanical departments of some roads.

Every master mechanic and shop foreman who takes an intelligent interest in his business, can readily appreciate the saving of time and expense that would result in the repairing of railroad rolling stock if parts were kept in stock ready to put on when repairs were called for. Those who do not recognize the importance of this are not a credit to the business. It is about half a century ago since the more advanced class of railroad mechanics began advocating the use of interchangeable parts to facilitate rolling stock repairs. For forty years the expatiating on the advantages of an interchangeable system has monopolized the time of railroad men's meetings and the pages of the railroad press. Few men in charge of railroad rolling stock are to be found who do not indorse the inter-

changeable system and yet we do not know of a single surface railroad that has the system properly in practice. There are roads where duplicate parts are kept in stock for certain engines and much saving in time and expense results; but there is no railroad that has in practice the perfected interchangeable system followed in many other lines of machine work. The question naturally arises: Why do profession and practice disagree so thoroughly as they do on this important matter?

The different mechanical superintendents, if asked to answer this question, would reply enumerating difficulties that beset their particular cases, and we should receive a mass of conflicting testimony. A careful study of the question leads us to believe that the failure of railroad companies to put into practice a successful system of preparing interchangeable parts for repair work is due principally to the practice of depending upon drawings for dimensions and upon the 2-foot rule for measurement. There are other obstacles that hinder the establishing of practical standards, such as the diverse character of the engines and cars purchased from different makers, but the real difficulty that has frustrated the progress towards interchangeability is the blue-print and the box wood rule. Both of these things are highly useful in their way, but as a means of maintaining machine parts of exactly the same size, they are a failure.

The thing works in this way: A superintendent of machinery gets out drawings for a standard locomotive or car and a class is established. Rolling stock is built at different times and in different shops, according to the drawings. In laying out the work for the different parts, a scribe line is  $1/64$  in. to one side, dividers have led to  $1/16$  in. error in another place, and the trifling mistakes of those who lay out and those who execute add up till very few of the parts can be taken from one engine and put upon another without fitting. Parts that require fitting are not interchangeable. Files are not permitted in our first class machine shops where interchangeable practices are followed.

A well-known master mechanic in charge of extensive railroad shops who has done important work in making parts really interchangeable, insists that the general use of templates is the proper move in that direction. He maintains that if railroad companies would establish in connection with their mechanical headquarters, a place where templates would be made by expert workmen for use of all the shops on the system it would be the best paying enterprise the company could undertake. It is highly important that only fine workmen should be employed making templates. This system has worked wonderfully well when

properly managed. The templates are made by mechanics accustomed to accurate working with good instruments of precision to keep the measurements correct. The development of such a practice secures uniformity of all parts made by the templates.

Unless special attention is devoted to maintaining accuracy the free and easy habits of the American mechanic will make his own sizes. There are said to be about ten sizes of the Master Car Builders Standard Axle.

#### Brain Power.

In the discussions that are constantly going on relating to various phases of engineering we are continually meeting the expression "horse power," but there is another power rarely mentioned that exercises wonderful influence upon the affairs of mankind, that is "brain power."

One of the most striking peculiarities among men and women is the diversity of character and of ability. Some people are dull and stupid while others shine with quickness and capacity for planning and doing things that are of the utmost importance to themselves and to the world. What makes one person a dunce and another a genius? It is no doubt the difference in brain power. The influence of brain power on individuals is of very high importance to their progress and success in life; but it is when we turn to the history of nations and of corporations that we find brain power a tremendously vital force.

People of mature experience can remember corporations that seemed to begin business with the brightest prospects of achieving a prosperous career, and yet met with nothing but failure and misfortune; other concerns again that started out in a struggling fashion, waxed gradually prosperous and have become leaders in the manufacturing and financial world. These experiences apply to individuals just as much as they do to corporations, as the difference in results is due to powerful brain power being employed in the successful cases, while lack of that power has paved the way to the misfortunes of the others.

The familiar manifestations of superior brain power are ability to perform business better than competitors. There is very little benevolence in business, and the secret of success of an individual or a corporation lies in its or his ability to do better than the present or future competitors. In connection with the desperate struggle now going on in Europe, we hear much said about superior weapons and methods of fighting, but we may rest assured that where superiority prevails, brain power is the force that obtains the advantage.

When an individual fails to achieve success in life, we frequently hear numerous

explanations given, but seldom a word said about deficiency of brain power, which is the real cause of failure. People who act on the belief that the world owes them a living, nearly always fall behind in the race of life. The world owes not any one a living if he fails to realize and act on its responsibility. So in corporations and combination of capital, they are subject to the survival of the fittest. This requires, not that they shall do as well as their competitors, but better. Every one struggling in the race of existence should be students to discover better methods, more efficient apparatus and of every detail that contributes to success and put them into practical operation. Conditions of this character present opportunities that only the ambitious student can realize and those with sufficient brain power make the best of them, that best which means success. We frequently hear the complaint made that there are few opportunities nowadays for building up a successful business; but those who make such complaints are deficient in observation. There were never such good opportunities for success in business as there are today for those who have sufficient brain power to grasp the true situation.

#### Settling the Size of An Inch.

We have recently taken occasion to comment upon the inaccuracies that frequently occur in measuring with the ordinary foot rule, as a reason why standards measured by correctly made templates should be employed. Whilst studying this subject we found information that indicated great confusion in the size of the inch at one time.

Nowadays the inch of every well-regulated machine shop is precisely the exact size—one inch. It is within the memory of men still living, when a different condition of affairs existed. The inch marked on the rules of different makers was seldom approximately the same, and the best of measuring scales rarely made the inch the same length so that 1/32 inch difference in the foot was not considered out of the way. In fact, there was no accurate unit of measurement on this continent till about 1870.

Railroad engineering people are entitled to much credit in reforming the confusion that prevailed in measurement. A committee of the Franklin Institute made the first important move towards getting a standard system of screw threads introduced, and it was in connection with that the need of an accurate inch came to be recognized. When the famous engineer, O. B. Chanute, was in charge of the mechanical department of the Erie Railroad in the early 70s, he decided to have interchangeable screw threads used on a large number of cars to be ordered. When he entered into details, the first difficulty encountered was

finding the correct size of the inch. He applied to the various Government arsenals and shipbuilding yards and obtained scales giving the standard inch they were working from. On a comparison being made, it was discovered that none of the reputed accurate makes were hardly the same length. Mr. Chanute was a highly influential railroad officer and a leading member of the principal engineering societies of the day, so he had good opportunities for making the anomolous condition of American measurements well known to the engineering world. He tried hither and thither seeking for a true inch, like the ancient philosopher seeking for an honest man, and his quest was equally fruitless.

The agitation, however, brought about the necessary reform. The question was taken up to the Master Car Builders' Association, and a committee was appointed to select a firm to make gauges for standard screw threads. The choice fell upon Pratt & Whitney Co., Hartford, Conn., and that company displayed wonderful enterprise in providing the country with a correct standard inch of measurement.

The labor performed was enormous and the expense incurred was not less than \$25,000. The first thing to be done was to ascertain the length of the standard British yard, which was the original gauge of our measuring rules. This yard was made with extreme care in 1760, and was deposited for safe keeping in a strong room in the Houses of Parliament in London. The Houses of Parliament were burned in 1834, and the standard yard destroyed. After a most laborious and painstaking investigation, the new standard yard was made from others considered correct.

To obtain an accurate transfer of this yard was the first work done by the Pratt & Whitney Company. They engaged the services of Professor Rogers, of Harvard College Observatory, who was then considered the first authority in the world on measurements and measuring instruments. The work was successfully performed and the vast machine interests of the country are now enjoying the benefits of absolutely standard size measures and accurate gauges.

#### Boiler Circulation.

Every locomotive engineer of observing habit is aware that the boiler of a locomotive steams more freely when means are provided for promoting circulation of the water, than when the water is permitted to lie inert on the heating surfaces. When the water feeding injector first came into use many locomotive engineers objected to using and caring for it on the ground that it was an extra and unnecessary apparatus to care for, but extended experience demonstrated that the boilers fed by injectors steamed more freely than those fed by force pumps.

There were at times on some roads considerable controversy on the question of why a boiler fed by an injector should steam more freely than one fed by pumps and the question remained a mystery to most engineers, but we have always felt that the superior steaming qualities were due to the increased boiler circulation that resulted from the use of the injector.

We believe that a considerable portion of the boiler saving produced by superheaters is due to the improved water circulation that results from a superheater being placed inside of the boiler. The fact that the water is kept in movement with the charging flow of water coming in contact with the hot surfaces must produce greater evaporation than when sluggish movement keeps the same body of water in contact with the evaporator surfaces. This is a matter that has never been properly investigated and has not been considered so important as it deserves to be.

#### Urges Help for Railroads.

A special despatch from Baltimore to the *New York Times* says that President Willard of the Baltimore & Ohio Railroad has just returned from a long trip over the line and is convinced that the railway systems of the country must be vouchsafed a fair degree of prosperity to properly bear the extraordinary burdens of preparing for a future war in which the United States might engage. While away, Mr. Willard discussed the problems which the railroads would have to face in preparing the properties for war conditions.

"What the situation is now," said President Willard, "may be understood when it is realized that last year, for the first time since the civil war, the number of miles of new line constructed was less than 1,000. Net revenues of the roads are less than they should be, owing to the fact that rates have not advanced in proportion to operating expenses. In the case of the Baltimore & Ohio, for instance, it cost \$4,500,000 a year more for labor than it did five years ago, and \$1,000,000 a year more for taxes. During the last six years \$120,000,000 has been spent for improvements, and the interest on this must be added. For a number of years the railroad has been declaring a dividend of 6 per cent. on its common stock, but at the last meeting of the board of directors a dividend of 2½ per cent. was declared, which is at the rate of 5 per cent. per annum."

#### Pamphlet on the Electro-Pneumatic Brake.

For particulars of our new pamphlet describing and illustrating the Electro-Pneumatic Brake for passenger service see page 106 of the present issue of RAILWAY AND LOCOMOTIVE ENGINEERING.

# Air Brake Department

## Handling Brakes on Yard Shifting and Passenger Car Service, and Daily Inspection of Locomotive and Tender Brakes

Before taking up the subject of handling brakes on passenger trains, it should be of advantage to first consider the subject from a view point of smooth handling beginning with yard shifting service, as it will lead to a better understanding of the requirements of road service, for if trains with various brake equipments can be handled smoothly at low speeds it certainly can be done in road service at higher rates of speed, therefore we print a number of suggestions that were formulated to cover a passenger yard shifting condition where all modern types of brake equipments are indiscriminately mixed.

When shifting cars with the air hose between the engine and cars uncoupled, do not use the independent brake valve in quick action application position except in cases of emergency.

When applying the independent brake, it should be graduated on, the idea is to take up or let out the train slack slowly, and after the slack is all out, or all in as the case may be, the brake can be applied as heavily as necessary to make the stop, that is, instead of making a twenty-five or thirty-pound application, aim to make the first admission to the brake cylinder from five to ten pounds and return the valve handle to lap position. Then add ten more pounds and again lap the valve, after which the brake may be applied with any degree of force necessary. This method of application may have to be started a trifle sooner than is the present practice, but the coupling slack will be given more time with which to change and the stop will be smoother.

When releasing the brake under such conditions, it should be graduated off, that is, exhausted from the brake cylinder in steps of eight or ten pounds at a time, which would gently release the tension on the draft gear springs instead of their compression tending to throw the engine away from the cars.

In coupling to a train of cars, it is a good practice to make a twenty-five or thirty-pound reduction with the automatic brake valve, after the engine is coupled and before the air hose have been coupled. This will give the air pump a chance to hold the main reservoir pressure at the maximum and tend to prevent a re-application of brakes on the engine and the consequent waste of main reservoir pressure through the brake cylinders that could be used to a better advantage through the brake pipe for charging the train.

When handling one or two fully charged cars, and it becomes necessary to couple up to a number of partially charged or uncharged cars, the stop to make the coupling should of course be made with the automatic brake valve, and before the hose can be connected, the reduction should be continued, to make a total of twenty-five or thirty pounds.

This will be of advantage especially in handling "LN" equipment, as such a reduction will prevent the crew from making a quick action or emergency application should the angle cocks be opened too suddenly.

The quick action or emergency application on "LN" equipment develops the high brake cylinder and auxiliary reservoir pressure which prevents a prompt release of brakes, therefore if it can be prevented, an opening of the angle cock will bring the auxiliary reservoir pressure down to sixty pounds, thus insuring a prompt start of the triple valves to release position, and the supplementary reservoir pressure will be used to charge the auxiliary reservoir thus permitting of no drain whatever on the brake pipe of the charged cars while brakes are releasing.

When coupling one or two fully charged cars with a number of uncharged cars, should a prompt movement and another stop be necessary, a service brake pipe reduction, if made within two or three minutes of the time the couplings were made, could not be expected to cause a brake application on the uncharged or partially charged cars. Therefore the brakes applying on the locomotive and charged cars would permit a run in of slack from the cars on which the brakes did not apply, which results in a severe shock. The only way in which this can be avoided is to either wait until the cars have charged before attempting to use the automatic brake valve, or bunch the slack with a light application of the independent brake valve before the automatic valve is used.

In stopping a train with the brake, the automatic brake should be used, as the automatic brake valve is intended for applying the locomotive and train brakes and the independent brake valve for handling the brake on the locomotive alone. However, if the use of the independent brake valve and train slack conditions are thoroughly understood the independent valve can sometimes be used to advantage in controlling changes in train slack.

The distributing valve must be maintained in a condition to apply with from a four to five pound brake pipe reduction.

When stopping a draft of cars, the amount of initial brake pipe reduction should be governed by the type of brake equipment being handled rather than by the rate of speed at which the draft is moving, because the rate of speed in yards is comparatively low.

In handling equipment, which is largely "LN," from four to five pounds reduction is sufficient for the initial brake application. The quick service feature of type "L" triple valves makes it possible for these light reductions to apply all brakes in the average train, and as the actual cases of undesired quick action is practically negligible, this light reduction is permissible regardless of the fact that the light reduction ordinarily tends to produce undesired quick action of triple valves. In fact, if a brake works in quick action on a light brake pipe reduction, it is very likely to do the same thing with a heavier one, and in either case it is caused by a disorder that must be located and removed.

In handling "PM" and "UC" equipment the initial reduction should be from five and a half to six and a half pounds, first for the reason that the universal valve will not apply with less than a five or six pound reduction, and there is no quick service feature in the "UC" or "PM" equipment and practically all of the brake pipe reduction must escape through the brake valve, hence a trifle heavier brake pipe reduction is not only permissible, but is necessary.

In making a brake application the handle should be brought from running position directly to service position, with no stop of the handle on lap position, this practice is slangily termed, "Loafing on Lap," and is responsible for the occasional quick action application of the brakes when service is intended.

No brake application should consist of less than a ten or twelve pound total brake pipe reduction. If the initial light reduction stops the train at the desired point, make enough more brake pipe reduction to total ten or twelve pounds after the train stopped and before an attempt is made to release brakes.

The light total reduction during a stop is responsible for numerous cases of brakes sticking which could otherwise have been avoided. The light reduction leaves the pressure in the brake pipe too near the point of feed valve adjustment

to insure the differential of pressure necessary to accomplish a prompt release of brakes.

The object of a light initial reduction is to permit the draw bar and coupling slack to adjust itself, the idea is to gently gather up this slack, therefore, if a smooth stop is desired there must be time enough allowed for this to take place between the first and second brake pipe reductions, even if the first reduction must be made a trifle earlier than is now the practice in operating brakes on drafts of cars.

Shocks to trains and rough handling is caused by rapid changes in draw bar and coupling slack, or in other words due to differences in rate of speed between two portions of the train, and when this occurs from the use of the brake it is due to a difference in braking or retarding effect originating from differences in brake cylinder pressure, obtained as a result of differences in auxiliary reservoir pressure on different cars, or due to differences of load in cars, or differences in the braking ratio employed in brake installations on different cars to too heavy an application of the brake on the locomotive alone, or due to leakage continuing the reduction after the brake valve closes.

For this reason the first reduction should be light, the object being to develop a brake cylinder pressure that will be too low to set up a rapid retarding effect while the slack is adjusting itself.

The brake can be used in a manner to control the change in slack instead of causing the rapid change.

The secret of smooth train handling is ability to control the slack action by the use of the brake and occasionally with the assistance of the engine throttle also.

On the first brake pipe reduction made on a draft on straight track, it is absolutely essential to smooth handling to know whether the tendency of the braking effect is to cause a running in or a pulling out from the cars at the rear end, and the brake must be handled accordingly.

The initial brake application results in a running in from the rear, the slack should thereafter be bunched by a very light application of the independent brake before the automatic brake valve is used.

If the tendency is for the slack to run out towards the rear, the automatic brake should be applied when the train is stretched, even though it is necessary to keep the throttle partly open in order to accomplish this.

Both of the former instructions are subject to variations when the draft of cars is on a sharp curve or a portion of the draft is on a grade, where the curvature or the grade may change slack conditions.

As an example of the foregoing, the distribution of braking effect may be such

as to permit of a run in, or a crowding in, of the rear cars when on a level track, but when the rear cars of such a train happen to be on a sharp curve the retarding effect is sometimes greater than the differences in braking effect that will be obtained between the different cars as a result of the light brake pipe reduction, hence the condition would change and instead of bunching the slack, the train should be left stretched when the brake is applied.

As another example, if it is necessary to release the brakes while the rear cars are on a curve, the slack must be held in by a full application of the independent brake as a movement of the brake valve to release position and promptly back to running, will release the engine brake and permit of the tendency for the engine and head cars to run away from the rear ones in the curve, generally causing a severe shock and occasionally with heavy locomotives break-in-two of train.

Again if the train is being backed into the curve, the conditions will be reversed and if a release of brakes is to be made the brake should be entirely released on the engine so that it, and the cars next to it, will drive it solidly against the cars on the curve, then should another brake application become necessary the independent valve should be held in release position while the brake application is being made.

Do not attempt to move a draft or make a shift until after the brakes have released, no time will be gained in the total movement and only rough handling will result.

In releasing brakes, the time the brake valve handle is allowed to remain in release position is governed by a variety of conditions, but where the main reservoir volume and pressure is uniform and the air pump capacity is the same, the time in release position is governed principally by the number of cars in the train and the type of brake equipment on the cars, and the pressure in the brake pipe and auxiliary reservoirs.

More care must be exercised with the brake valve in release position with  $8\frac{1}{2}$  cc. air compressor capacity, so that there may be no possibility of brakes reapplying or sticking from an over-charge of the reservoirs on the cars next to the engine.

When releasing the brakes under ordinary conditions, the brake valve handle should not be allowed to remain in release position for more than one second on trains of from two to six cars, and not over three seconds on the longer drafts.

After the first movement to release position when releasing brakes on long drafts, a second, quick movement to release and back to running position is frequently necessary and should be made if the brake pipe pressure is somewhat

lower than that in the main reservoir immediately after the release.

If the brake pipe reduction made before the release has been heavy enough to draw the main reservoir pressure down to, or below, the figure of the adjustment of the brake valve feed valve (110 pounds) this is permissible and sometimes necessary, especially in cases of brake pipe leakage when a second or third movement to release will be found to be of advantage. This is slangily termed, "Flashing the brake valve."

To know why this will be necessary it should be understood that the feed valve cannot operate and supply brake pipe leakage or a drop in brake pipe pressure through the triple valve feed grooves if the main reservoir and brake pipe pressures are approximately equal, as the tension of the supply valve piston spring of the feed valve plus the frictional resistance, usually ranges from eight to ten pounds difference in air pressure, therefore in order to obtain any material supply of air from the main reservoir through the feed valve the main reservoir pressure must be from ten to fifteen pounds higher than that in the brake pipe. Hence these quick movements of the brake handle to release position will maintain the brake pipe against leakage and hold the brakes released while the pump or compressor is accumulating the necessary excess pressure with which to operate the feed valve.

A distinction must be made between releasing brakes and charging the brakes on a draft of cars, if the main reservoir pressure equalizes with the brake pipe at some point below one hundred pounds, the brake pipe and reservoirs must be charged, and release position of the brake valve is the correct position for doing this work. The valve handle should remain in release position until both hands of the air gauge show nearly one hundred and ten pounds, when the brake valve handle should be brought back to running position. It is not always necessary to bring the valve handle directly from full release to running position because the volume of compressed air that enters the brake pipe can be reduced or increased as the brake handle is brought to, or away from, running position.

This position, partially in release, or in full release gives a wide open or a large port from the main reservoir to the brake pipe which quickly admits the volume of compressed air from the main reservoir into the brake pipe, and incidentally permits the pump to work more rapidly against a lower air pressure, thus releasing the brake and recharging the reservoirs in the shortest possible space of time.

If you will understand that this subject of train handling is too broad to be covered with written instructions and that no air brake men will attempt to lay

down any fixed rules to cover various conditions, you will realize that in order to handle the brakes in a manner that will be above criticism it will be necessary to make a study of every condition surrounding each train movement, and to thoroughly understand the construction and operation of every one of the various car brake equipments as well as that of the locomotive.

You should understand that the most important lapse of time, from the viewpoint of smooth handling, is that between the initial and second brake pipe reduction during a stop, as this must be of sufficient duration to permit the train slack to gently adjust itself to surrounding conditions.

When the stop is to be made with the back-up, or rider hose, you will assist in smooth handling by refraining from giving any assistance with the brake valve except in actual cases of emergency, and further by knowing that no undue or unnecessary leakage exists in any part of the brake system on the engine.

In the event of low steam pressure, where the air pressure in the main reservoir falls to approximately that carried in the brake pipe the brake valve handle should be carried in release position until the steam pressure is regained, as this will add the main reservoir volume to that in the brake pipe making it more difficult for brake pipe leakage to apply the brakes. Some care must be exercised in getting the valve handle from release position back into running if there happens to be any material leakage in the brake pipe and the safest method is to leave the handle in release position until such a time as a 30 lb. brake pipe reduction can be made.

Another essential observation in connection with the time element is that which elapses between the time of movement of the brake valve to release position and the opening of the engine throttle, be sure that the brakes on the rear cars have had ample time to release, and if possible be sure that they have released before attempting to start the train and under many conditions of service this may have to be reckoned in minutes instead of seconds in time.

#### Daily Inspection of Locomotive and Tender Brakes.

In order to comply with the Federal Law covering the inspection of locomotive and tender brake equipments, which specifies that the brakes be constantly maintained in a safe and suitable condition for service, we have formulated a method of inspecting the E. T. locomotive brake which, if followed in the right spirit, will meet the requirements of the

law. At a first reading it may appear to be a trifle too rigid or exacting or may appear to involve an unnecessary expenditure of time, but if thoroughly learned and put into practice it will be found to contain but very little more than that specified in standard recommended practices and can be made in from 12 to 14 minutes time. Of course the inspector could not be expected to do any air brake repair work on the engines, as his capacity for inspection would not be much over three engines per hour, which at large terminals means an increase of force, but we are at this time more concerned with the requirements as laid down by the law than by the expense incident to complying with it.

1. Start the brake inspection with approximately 50 lbs. pressure in the brake cylinders, the independent brake valve in lap position and the automatic brake valve in running position.

2. Close the stop cock in the distributing valve supply pipe.

3. Beginning under the engine at the pilot, test brake cylinders and piping with torch, measure piston travel, see that cylinders and cylinder bolts are properly tightened, that brake rigging is in its proper position and that no part of the rigging is less than  $2\frac{1}{2}$ " above the rail.

4. Test air hose between engine and tender, and air pipes under tender, examine tender cylinder and all pipe clamps and measure tender brake piston travel.

5. Coming out at the rear of tender go to the right side of the engine, examine all piping about the distributing valve, and distributing valve exhaust port for leakage, examine equalizing and main reservoirs for leakage, and all reservoir hangers and pipe clamps, drain right main reservoir and note last date of hydrostatic test.

6. Follow the brake and signal pipes to the pilot, examining pipes and clamps, note condition of air hose and gaskets on pilot, and test piping between hose and stop cocks on pilot.

7. Continue from pilot to left side of engine, testing all pipes, test left main reservoir and related piping.

8. Open left main reservoir drain cock, note date of last test, and inspect air pumps for leaks. Note that pumps or compressors draw in air on both strokes of the piston, and report any leakage or blow back at the stuffing boxes or air strainers; see that strainers are clean and report any overheating, pounding, lameness or unusual action of the pumps.

9. Close main reservoir drain cock, and attach gage or preferably a test coupler to the hose at rear of tender; see that signal whistle gives four distinct blasts of the whistle through a 1-16 opening and that the pressure is correct and is promptly restored after a reduction.

10. Test the feed valve for sensitiveness through a 3-64-inch opening to the atmosphere, feed valve must operate upon this amount of leakage and the fluctuation of pressure as shown on the gage must not exceed 2 lbs.

11. Note the condition of the air hose and the figure of feed valve adjustment; remove the test gages and immediately enter the cab and note that the brake pipe pressure as shown on both air gages corresponds with that shown at the rear of the tender.

12. Close the air pump throttle and place the brake valve on lap position; test all air pipes in cab and above the running board and the brake valve exhaust ports for leakage.

13. Inspect last date of air brake cleaning tag under the brake valve, or as shown by the form under glass inside of the cab; note date of last air gage tests and last date of air compressor test and report any found out of date.

14. Note drop in air pressure as indicated by the air gages during this interval in one minute of time, brake pipe pressure must not fall more than 5 lbs. nor the main pressure reservoir more than 3 lbs. If main reservoir pressure, due to high temperature of the compressed air, drops more than 3 lbs. per minute, another test must be made when the pressure has reduced to 85 lbs., and the pressure must not fall more than 9 lbs. in three minutes. This is a very liberal figure for leakage tests and there is no reason why the main reservoir leakage cannot be kept down to 2 lbs. per minute and the brake pipe to 3 lbs.

15. If five minutes time has elapsed since the closing of the distributing valve supply pipe cock, note the brake cylinder pressure as shown on the gage; see that brakes are still applied and open the cock in the supply pipe. If the brake has leaked off the cause must be ascertained or the fact reported.

16. Test the equalizing portion of the distributing valve for sensitiveness by making four or five brake pipe reductions to equal 5 lbs. total. The 5 lb. reduction should apply the brake and the pump governor should be sensitive enough to start the compressor as the reduction of pressure in the main reservoir takes place.

17. Make 15 lbs. more brake pipe reduction to see that 50 lbs. brake cylinder pressure is obtained for the 20 lb. reduction. See that the operation of the equalizing discharge valve of the brake valve is correct at this time, and that there is no leakage from any of the exhaust ports of the brake valve.

18. Make 15 lbs. more reduction to see that the brake cylinder pressure does not increase beyond 68 lbs., then draw the brake pipe pressure below that in the



brake cylinders to see that there is no back leakage from the brake cylinders into the brake pipe.

19. Release with the independent brake valve, application cylinder pressure should be practically exhausted in from two to three seconds.

20. Move the automatic brake valve to release position and compare the pointers of the large gage to see that they and the black hand of the small gage register the same pressure.

21. Leave the valve handle in release position long enough to overcharge the pressure chamber of the distributing valve to 125 or 130 lbs., then make a brake pipe reduction sufficient to apply the brake and return the valve handle to running position. With the brake pipe pressure still above 110 lbs., the brake should remain applied to insure that it will remain applied when the engine is the second one in double heading.

22. Reduce the brake pipe pressure to 110 lbs., then from 110 to 90 lbs., and see that the equalizing reservoir reduction takes place in from five and one-half to seven seconds time, or from 70 to 50 lbs. in from nine to eleven seconds.

23. Return the valve handle to holding position and note that brake pipe pressure is promptly restored to the figure of feed valve adjustment, and that there is no loss of application cylinder pressure; test release pipe branch between the brake valves and return valve handle to running position.

24. After brake has released, move the independent brake valve to slow application position; 40 lbs. brake cylinder pressure should be obtained in from six to eight seconds, and the final pressure should be the same as shown on the test gage when the signal whistle was tested.

25. Test the sensitiveness of the application position of the distributing valve by graduating the pressure out of the cylinders by alternating the valve handle between lap and running position. If the distributing valve operation is correct this can be done in steps of from 5 to 7 lbs. at a time.

26. Release the brake entirely and move the independent brake valve to quick application position; 40 lbs. cylinder pressure should be obtained in from two to three seconds.

27. Test air sanders or any other air operated devices.

Air pumps are out of date for test in three months time, air gages in three months and the brake equipment in six months. Main reservoirs are out of date for hydrostatic test in twelve months time.

The maximum piston travel permitted by law is 6 in. for the drivers, 8 in. for the trailer and truck brakes and 9 in. for the tender brake.

## New Anti-Collision Fenders on the Great Central Railway of England

One of the leading express trains of the Great Central Railway of England, running between London and Manchester, has been fitted with a new arrangement of inter-locking, anti-telescoping fenders, and anti-collision buffers, the invention of Mr. J. G. Robinson, Chief Mechanical Engineer of the railway. The arrangement

designed to take a working load of 5 tons, and a reserve stroke of 15 tons, giving a combined resistance of 20 tons, which can be increased to 35 tons if desired. The spiral springs are so arranged on the piston of the buffer that after the ordinary buffer has been driven up to the working limit, and the shock be still greater, the bolts which hold the springs are so designed as to break away at about 50 tons pressure on each buffer, or 100 tons pressure on the end of each vehicle, thus allowing each buffer to recede, and allowing the anti-telescoping fenders to become interlocked to prevent the vehicles from mounting on each other. The bolts referred to are reduced in diameter for a part of their lengths so that they will break under a pre-determined shock, and larger springs and bolts may be used to suit heavier loads if considered necessary.

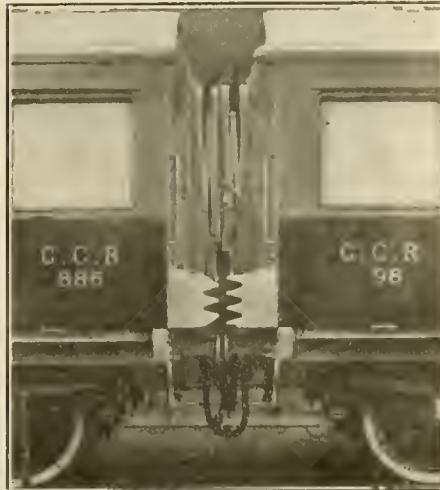

VIEW OF ANTI-TELESCOPING DEVICE.

of corrugated steel interlocking fenders shown in the accompanying illustrations of the ends of the carriages, is intended to preserve the alignment of the train in a lateral as well as in a vertical direction to prevent telescoping of the vehicles in the event of a collision, as they act at



VIEW OF CUSHIONING BUFFERS.

practically the full width of the underframe.

The improved cushioning resistance buffers are also adapted to considerably mitigate the severity of a collision. Each buffer is fitted with strong spiral springs

### Car Hogs.

The persons who push pencils for railway papers have done much to make us familiar with the appearances and habits of the car hog. This animal goes on two legs but acts as if no other person on the car was entitled to comfort or convenience. He occupies a whole double seat and part of the aisle, saying uncivil things when any other passenger tries to interfere.

Some of our female friends assure us that certain women passengers are greater hogs than male passengers can possibly be. One of them, resplendent in silks and laces, gets first into the lady's dressing room, locks the door and remains inside for an hour while less fortunate sisters are waiting in torture outside the door.

### The Influence of One Man.

Emerson says, "A great institution is the lengthened shadow of one man." People who have had experience traveling on the Erie Railroad thirty years ago and today will note a tremendous change for the better. Cars are now clean and comfortable, while trainmen are civil and obliging. That is a gratifying improvement which people familiar with the change recognize as the genial metamorphosis of F. D. Underwood.

### Be as Good as Your Word.

All railroad men ought to realize that their promise to a passenger is the promise of the company. A broken promise always hurts and shows weakness on the part of the company just as much as it would reflect upon an individual who proved worse than his word.

# Electrical Department

## Largest Electric Passenger Locomotive Returns from San Francisco Result of Six Years of Electrification of the St. Clair Tunnel

What is said to be the only electric locomotive equipped with a smoke stack, has recently completed a transcontinental tour from San Francisco to New York where it is used by the Pennsylvania Railroad in hauling trains under the Hudson River between its New York Terminal and Manhattan Transfer.

The locomotive is returned from San Francisco where it was mounted on a turntable in the Transportation Palace of the Exposition, forming the center of the exhibit of the Westinghouse Electric & Manufacturing Company which furnished the electrical equipment for it. At the Exposition it was awarded the Grand Prize, the highest award in the gift of the Exposition, on account of its operating record, it having traveled over 120,000 miles before it was removed from

### Results of the Electrification of the St. Clair Tunnel.

It is always interesting to have an authoritative report on important changes in railway construction and equipment after a lapse of time, so that the new conditions may have had that guarantee of tests that can only come with service experience, involving various conditions, which very frequently furnishes new phases and food for thought that were not apparent at the original installation, which is usually full of an assured success that is not always completely realized.

From a report just published by Mr. Walter D. Hall, superintendent of the St. Clair Tunnel, we reiterate the facts which were previously published in the

vice for a few hours each day for two or three weeks before going into full service. The engineers who first assumed control of these locomotives are still operating them, and, with two exceptions, the same firemen, now called assistants, are with them. During this period not a passenger or a member of a train or yard crew has been injured by electric shocks, but two casualties have occurred to workmen in the electric bay. Means are now used so that it is not necessary to energize the lines in the bay except to move locomotives into the yard, and as soon as this is done the line in the bay is shut off.

The cost per year for the maintenance of the four steam locomotives was \$21,173, while the average cost for the six electric locomotives is \$11,131. The cost



PENNSYLVANIA PRIZE ELECTRIC PASSENGER LOCOMOTIVE RETURNS FROM SAN FRANCISCO.

regular service in the New York Terminal and sent to San Francisco for exhibition purposes.

The reason of the smoke stack is that the Pennsylvania and Westinghouse companies, wishing to insure its safe and prompt return from San Francisco, have sent with it a personal tracer, and in order to afford him comfort when passing through severe storms which have recently been encountered, a cab was erected, in which was included a small coal stove, hence the smoke stack.

The locomotive is rated at 4,000 horsepower and is the largest electric locomotive ever built for exclusive passenger service. It is built in two units, and weighs 156 tons, and will haul a heavy Pullman train at a speed of 60 miles per hour.

pages of RAILWAY AND LOCOMOTIVE ENGINEERING that the tunnel is 6,032 feet in length, with approaches totaling 5,603 feet. Between the years 1890 and 1908 the traffic through this tunnel was handled by steam locomotives capable of hauling trains of 750 tons at slow speed. After the latter date single-phase electric locomotives were placed in service, and have been in constant operation ever since. Trains of 1,000 tons have been handled at a speed of ten miles per hour.

The steam locomotives were about 100 tons each. There are now six 3,300-volt electric units, weighing about 66 tons, of the Baldwin-Westinghouse type. The engineers and firemen who operated the steam locomotives were given instructions relating to electric equipment, and the electric locomotives were placed in ser-

vice for a few hours each day for two or three weeks before going into full service. The cost per year for the maintenance of the four steam locomotives was \$21,173, while the average cost for the six electric locomotives is \$11,131. The cost

per car handled by steam locomotives through the tunnel, approximately five miles, was 26.64 cents, the average cost by electric locomotives is 17.22 cents, although the capacity of the cars is now much greater than formerly. An interesting feature also is the fact that the electric locomotives are available for service about 90 per cent. of the time. No failure of main motors has occurred, but the armature windings have required repairs from time to time. Connection between the motors and the engine wheels, which is accomplished through a single pinion and gear for each motor; the pinions make a mileage of 64,000 to 118,000 miles. At first the largest mechanical expense was due to flange wear, the average mileage being about 25,000 miles between the turnings, but the

adoption of an electro-pneumatic wheel flange lubricator, invented by Mr. Hall, have already made a record of 184,000 miles between turnings.

The controllers require little attention and have given practically no trouble. The commutators of the air compressor motors and blower motors have not required turning since going into service, and only two armatures have been re-

\$17,186 per year, yet the average tonnage handled by the electric locomotives has been much greater than that handled by steam. The difference in cost is partly due to the fact that slack coal is now used, whereas hard coal was used for the steam locomotives; yet fewer tons of slack coal are consumed for all purposes than of hard coal for the steam locomotives alone.

**Variety of Lubricating Oils.**

One of the most successful investigators of scientific phenomena was Arthur Jules Morin, a French mathematician and engineer. The investigations he conducted on friction supplied the world with the most important book on the subject and he is still regarded as a reliable authority although he died in 1880. His experiments demonstrated that the friction of a cast iron shaft upon a dry ball metal bearing amounts to .2 of the transmitted power, while with a wrought iron shaft the friction is more than .25; therefore, if such shaft were dry and unlubricated one-fifth and one-fourth respectively of the total first costs would be wasted in overcoming friction. By careful lubrication of the same shaft, the loss may be reduced to .065 in the one case and to .089 in the other. Hence the importance of a good lubricant. One of the most essential points is that the lubricant be properly distributed over the surface on which it is required that just sufficient lubricant shall be used to relieve the friction without waste.

Putting aside the common characteristics of a good oil, such as the absence of acidity either natural or artificial and the absence of gumminess, one of the most commonly believed ideas is that an oil of high specific gravity is the best for lubricating purposes. Although this may be true in certain cases, yet from observation and experiments made over a long period we find that they are not always the best, and that the point upon which we must rely is viscosity. A very simple test of viscosity may be made with a French pourette graduate into 100 c.c. The pourette is fitted on a stand and filled with oil to be tested. After allowing all bubbles of air to separate, it is permitted to run through and the time it takes to do so is carefully noted. At the finish of the operation it will be found



ELECTRIC LOCOMOTIVE EMERGING FROM ST. CLAIR TUNNEL.

paired. At the commencement of electric operation there were a number of short-circuits caused by birds alighting on the arcing tips of lightning arresters, but the difficulty was overcome by installing porcelain perches for the birds to alight upon.

The average cost of material, tools and labor for maintenance per mile per year

The boilers used in generating the power have given good results, particularly when a good quality of slack coal is used; crushed mine coal is not as satisfactory, because of the excessive draft sometimes required to care for the very erratic coal conditions; at such times a blow torch effect may be set up when mine-run coal is used, which is likely to

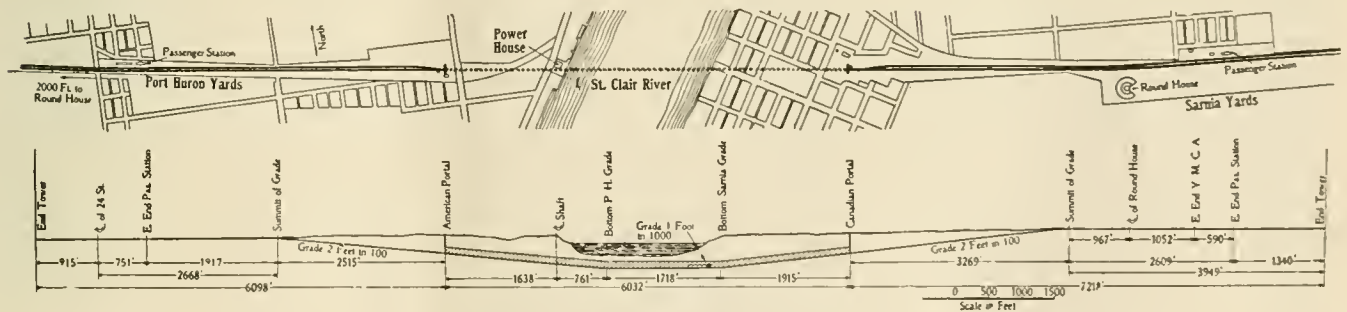

PLAN AND ELEVATION OF THE TRACKS IN THE ST. CLAIR TUNNEL AND YARDS.

of 12 miles of overhead construction and bonding of rails is \$127 for labor and \$72 for material and tools. The saving of track maintenance in the tunnel alone is estimated at \$1,500 per year.

The cost of fuel for the steam locomotives was \$42,729 per year, while the average cost of fuel consumed for generating energy for the electric locomotives is

result in blistered tubes. When not supplying energy for handling trains, the boiler fires necessarily burn low. Notwithstanding this, not a single stoker retort has been renewed since the fires were first lighted, nearly eight years ago. The results obtained speaks well for the design, as well as for the material of which the plant was constructed.

that the viscosities are directly proportional to the time taken. Thus, if a mineral oil takes 15 seconds and refined oil 45 seconds, the viscosity of repressed oil is three times that of mineral oil. The temperature may be either 60 or 90 Fahr., but the latter is preferable, as the oil may be subjected to that temperature when in use.

The next question arises, how is this viscosity basis to be applied? If an oil with very high viscosity were used to lubricate an engine of low horsepower, we should in all probability find, that instead of reducing the friction to a minimum, it would itself become a source of resistance and increase the oil. And conversely, if an oil of very low viscosity were used to lubricate an engine of high horsepower, we shall find that the friction would be but slightly reduced. So when we come to look at extreme cases, we see that there exists a very marked connection between viscosity and horsepower. A high viscosity is not suitable for a low horsepower, and conversely a low viscosity is not suitable for a high horsepower. And just as the case holds for these extremes, so does it hold for every point between them. The viscosity must always keep parallel to the horsepower.

#### Laws of Motion.

The three laws of motion, enunciated by Sir Isaac Newton, the famous scientist, form the foundation of all calculations that deal with the effects of force upon matter. These laws, coming as they did from a master mind, while plain and simple, easily understood by even a school boy, are yet so important that the proper assimilation of what they express would be of benefit to many who feel that they are masters of their chosen callings.

Newton's first law of motion states that every body will remain in a state of rest or of uniform motion in a straight line, except in so far as it is compelled by impressed force to change its status. The second law of motion states that the change of state, acceleration of motion, will be in proportion to and in the direction of the impressed force. Let us consider any large mass, an immensely heavy freight train or an ocean liner, if friction could be absolutely eliminated the force of a single breath would give motion to either of these great masses, and with friction and retarding influences removed motion would continue forever.

The motion would, indeed, be almost imperceptible, but it must be remembered that the giant force that moves the heavy freight or the ocean liner, may be considered as only the multiple of the feeble forces. A feeble force acting for a length of time commensurate with its feebleness and with no opposing force directed against it, would give to the immense mass the same velocity which the giant force imparts in a much smaller time.

It is not necessary to point out that the locomotive with one or two cars, or with no car, can start from rest and reach its greatest speed in very much less time than is required when it has to give acceleration to a heavy train, and even run-

ning light, the force exerted by the locomotive is not wholly expended in producing acceleration of its mass.

A large portion of this force is expended in overcoming the retarding effects of friction in its different forms.

In making comparative statements involving considerations of the acceleration of mass, it is customary to consider the force of gravity as the actuating cause; with the mass falling vertically under the influence of this force, all retarding effects, even the resistance of the air, are understood to be removed.

#### Use of Compressed Air in Shops.

"A constant reader" wants to know to what extent compressed air is used in railroad machine shops, what sort of compressors are used and if we do not think electricity would be a more convenient medium in transmitting small power? In reply we would say that compressed air is used very extensively in railroad repair shops and our impression is that it is so employed because it is more convenient than electricity. In most cases the air plant has been started in a small way by using a Westinghouse air brake pump as compressor. In some shops there are several of these pumps at work; we know of one shop that used for a time twenty-one Westinghouse pumps, but they have all been superseded by a special compressor.

Another reason which we think has established the popularity of compressed air as small power in railway machine shops is, that nearly all the machinists employed in such shops understand the handling of all air appliances and few of them are perfectly at home with electric mechanism.

#### Doctoring Feed Water.

When a person is sick with any complaint of a mysterious character or difficult to cure, he is very liable to fall into the hands of pretentious quacks who presume to have a cure for all the ills that inflict mankind.

We have often thought of this when reading the long list of compounds that have been recommended for softening the feed water of locomotive boilers. A locomotive boiler evaporates such an enormous quantity of water that a small percentage of solid matter forms a big deposit at the end of a month. This soon causes trouble and raises the demand for a remedy. The proper remedy calls for some knowledge of chemistry, a science that is little studied by the men responsible for the safe and economical operation of locomotive boilers.

Under these circumstances the persons responsible for keeping locomotive boilers in steaming order are ready victims of quacks who pretend to possess skill in doctoring feed water. The man hav-

ing a compound that acts as a precipitate of lime salts is the least dangerous of the large tribe that deal in remedies for prevention of scale in boilers. All kinds of vegetable substances and many mineral compounds have been put into boilers with little success. Some of the ingredients used do some good; others are positively hurtful. Cornstarch, potatoes, sorgum, brand compounds of petroleum are a few of the ingredients used on some roads. All of these substances act on the scale and tend to soften it, but they form a sort of mild homeopathic remedy that is permissible because it is not likely to do much harm. It is safe to say that a few pounds of caustic soda would be much more efficient than any of the ingredients mentioned.

Some of the companies that sell boiler compounds such as the Dearborn Chemical Company, prepare their mixtures to suit the water to be treated. Where this practice is followed it indicates intelligent dealing with a difficult problem. It is using scientific knowledge instead of ignorant pretense. The proper practice for a railway company suffering from the evils of boiler scale, is to have an analysis made of the water and send it to such a reputable concern as the Dearborn Chemical Company, of Chicago, and they may safely rely upon receiving a medicine that will affect a cure. But it is of the utmost importance that the medicine should be applied regularly. We have known cases where engine house officials were supplied with reliable ingredients for preventing scale which failed because they were not used. They would be applied for a few weeks and then the application would be neglected. Neglect generally brings bad results.

#### Green Meadows of Industry.

Blessed is he who has found his work; let him ask no other blessedness. He has a work, a life purpose; he has found it, and will follow it! How, as a free-flowing channel, dug and torn by noble force through the sour mud-swamp of one's existence, like an ever-deepening river there, it runs and flows;—draining off the sour festering water, gradually from the root of the remotest grass-blade; making, instead of pestilential swamp, a green, fruitful meadow with its clear-flowing stream. How blessed for the meadow, itself, let the stream and its value be great or small! Labor is life!

#### For Stronger Railway Machinery Parts.

It appears to us that automobile makers are following very sensible practice in the selection of particularly strong material to successfully resist the shocks to which motor cars are subject. In some respects the makers of railway rolling

stock might with advantage adopt some of the strong material that automobile makers have brought upon the market. Breakages of railway machinery are not so rare that railway people can afford to ignore all ideas of progress and improvement.

The progress inspiring automobile manufacturers in the British Isles may be understood from the statement made by our Glasgow agent, Mr. A. Fraser Sinclair, in his weekly letter to the Glasgow *Herald*:

During the last twenty years or so there has occurred one of the greatest changes in the history of metal manufacture, that is to say, the growth in the use of alloys of industrial metals. Twenty years ago manganese, nickel, chrome, and tungsten were all used to some extent; but since then other and better processes have been introduced, while other alloys have also been discovered and employed with the happiest results. Combinations of alloys, with which carbon is generally employed, have had the effect of securing greater hardness, tensile strength, and elasticity as required for different purposes. Thus carbon-nickel-chromium, nickel-chromium-vanadium, carbon-chromium-vanadium, silico-manganese, and other combinations of alloys, all in differing proportions, are now employed according to the needs of the case. Many of these alloys have been evolved for the purpose of meeting the requirements of motor car manufacturers, and now a new, and what may turn out to be a revolutionary, development in connection with the use of aluminum is being discussed. A quarter of a century ago, and ever since, aluminum has been employed as an ingredient of steel, but the proposal now mooted is to use it as the metal in chief, with the addition of alloys in proper quantities to make it hard and tough enough to stand machining, and to permit of its use as cylinders, pistons, connecting rods, and other important parts. Should the day come for alloys of aluminum to reach the stage of strength and toughness required for those purposes, the revolution mentioned will not be far away. Aluminium, as demonstrated by the Harcourt radiators for air-cooled engines, has great powers of radiation, and one has but to imagine an engine in which the cylinders, pistons, combustion chamber and crankcase were all of aluminum, possibly of different alloys, to recognize that cooling by water would no longer be necessary. With water discarded there would go the water jacket, the radiator, the water connections—all of them of metals a long way heavier than the heaviest alloy of aluminum, and all less amenable to the action of cold air than that alloy. Moreover, there would be a vast reduction of weight at many points where such strengthened aluminum might be used with advantages in the lowering of run-

ning costs. Not that reduced weight is an unqualified benefit, the need for adhesion on hills demanding a reasonable minimum, but there are many designs of cars on the market which could be doing with a good deal of pruning to the very great benefit of their tire and petrol bills. But before the millennium suggested can come about there must be a great reduction in the price of aluminum, another economy depending on the end of the war.

#### Too Many Rules.

The officials of some railroads are a little too literal in framing rules for the guidance of trainmen. Considering the fast time made by many trains of the present day, the large number of trains run on the same track, many of them only a few minutes apart, and in general the many dangers that threaten trainmen and passengers, it is best that too many instructions should not be put upon the action of locomotive engineers, else they may hesitate in case of doubt; and it is assuredly true that when running at a speed of 60 miles an hour "he that hesitates is lost."

American railroad men have been famous for the ability displayed in overcoming difficulties as they arise, and for meeting unexpected emergencies with success. The qualities that have proved so valuable in this way, have been developed through the men being permitted to use their own judgment. Railroad operation is now exceedingly complex, and more formulated rules are necessary than formerly, but care should be taken that rules are not made so numerous, that an impression is given that the judgments of the engineer is no longer considered of value.

We recently called upon a railway manager who was writhing with the formation of a book of rules for trainmen, and he had gathered material more voluminous than the Old Testament and yet he was seeking more suggestions. His aim was to cover every event that could possibly happen with a rule for action. This sort of paternal management is not likely to produce good results. It is impossible for men to commit to memory voluminous rules, so the effect of issuing a code of that kind is the taking away personal responsibility without supplying a practical substitute. It is much safer to depend acting promptly on his own judgment in an emergency than to depend upon him thinking of a laid down rule.

#### The Catalan Forge.

A correspondent asks us what we know about Catalan blast furnaces and to what extent they are used in the United States.

The Catalan blast furnace had its ori-

gin in Catalonia in the North of Spain, and was used for blasting iron from the ore by means of wood or charcoal. We are not aware that any Catalan furnaces are now in use in the United States, but at one period such furnaces proved an important factor in promoting the iron making industries of the United States.

In our issue of February, 1892, there appeared an article on "The Oldest Boiler Plate Rolling Mill," from which we copy the following extracts: "About the finish of the War of Independence, when the infant States were famishing for want of iron, there sprang into existence in the valleys and hillsides near Coatesville, Pa., numerous Catalan forges where wrought iron was made directly from the ore. The advantage of this district on nursing such an industry, was the existence of great forests that provided charcoal, and fine waterpower that operated the crude mechanism employed.

"The presence of these Catalan forges and the great wood and water power privileges enjoyed led to the building in 1810 of the Lukens Iron Works, which afterwards developed into the Lukens Iron & Steel Co. The work done by this concern making iron plate from the charcoal blooms produced by the Catalan forges. Here the first plates for boiler making were rolled on the American Continent, and the product was so good that a demand arose in Europe for the charcoal plates that could not be obtained anywhere else."

#### Very Hard Steel.

We do not like the common "hard as fire and water can make it" used frequently in connection with the hardening of steel. It generally means that it is to be made coarse by overheating. It cannot be impressed upon the steel maker too often, that his aim should be to refine the grain, so that it will disappear when viewed by the unaided eye. The hardness will take care of itself. If it is not hard enough when refined by hardening at low heat, then the steel itself is too mild. Better take the steel maker into your confidence, and tell him what you want the steel to do; then he will give you what will refine to a strong condition and harden just right for your purpose.

#### Too Slow.

He stood and looked at the steam roller that was working on the asphalt in the San Francisco exposition. "Great thing, ain't it?" said a bystander. "Great nothing," was the reply; "you must be powerful slow in California when that's all the speed you make. Why out in Pine Center they'd shoot an engineer that couldn't go no faster'n that!"

# Porter Locomotives in Favor at Home and Abroad

As is well known, industrial locomotives, their construction and management, involves many questions not common to general railroad traffic. In what may be called the early days it was usual to transfer locomotives that had done service for many years, and, after giving

locomotives adapted for every kind of industrial service.

In the accompanying illustrations Fig. 1 shows what is known as a double-ender locomotive, with six driving wheels and saddle-tank. It is a coal burning locomotive, and among other orders for this

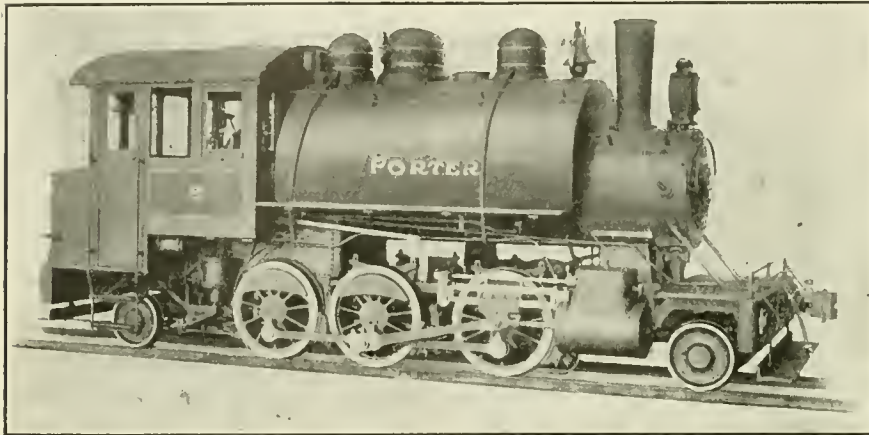

FIG. 1. DOUBLE-ENDER LOCOMOTIVE FOR UNITED STATES PENITENTIARY, FORT LEAVENWORTH, KANSAS.

them such overhauling as could not very well be dispensed with, the safety valves were adjusted at a considerably lower pressure, and they were repainted and sold at a reduced price to some struggling industry to relieve the patient mule from further drudgery. That such decayed locomotives occasionally blew up, even at the reduced pressure, was not to be wondered at. As a rule, they were rarely in skilled hands. Their boilers were not kept as clean as they might have been. Their loose joints were little heeded. When they came to a standstill there were few mourners.

All this is changed. Industrial locomotives are keeping pace with other kinds of locomotives, both in special construction of details and in excellence of material. Indeed, it may truthfully be said that the industrial locomotive is kept in advance of ordinary freight locomotives. They are compelled to meet conditions in regard to tracks that are poorly ballasted and meet many shocks that are not common on well kept roads.

Hence strength and durability of structure are essential requisites, and the necessity for maintaining a high degree of ruggedness under the hardest conditions is a pre-requisite of the modern industrial locomotive. The leading locomotive builders have met the situation admirably, and the improvement in this particular kind of motive power has been particularly marked during the present century. Among these enterprising firms that of the H. K. Porter Company, of Pittsburgh, Pa., has won an enviable distinction in the special attention that the firm has given to the construction of

type of locomotive, one was recently furnished for service at the United States Penitentiary, Fort Leavenworth, Kansas. The type of locomotive is well adapted for general service, being suited for logging, local passenger and other service requiring a fair amount of speed, good distribution of weight, steady running, ability to pass reasonably sharp curves and considerable power on quite heavy grades and on

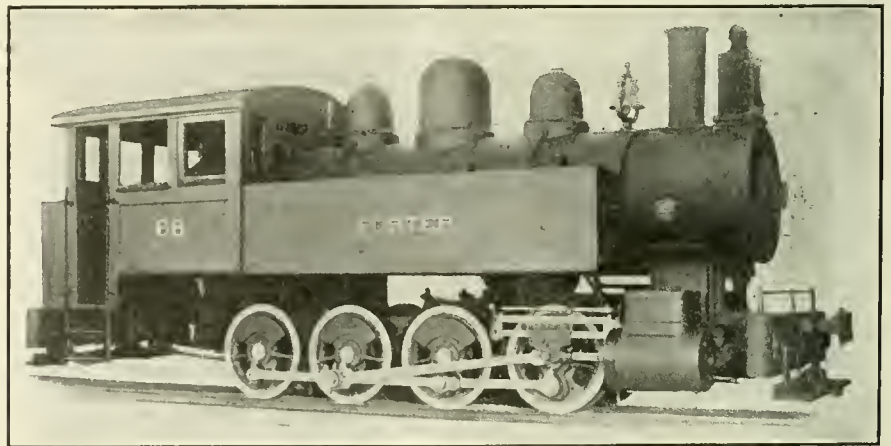

FIG. 2. EIGHT-WHEEL-CONNECTED SIDE-TANK LOCOMOTIVE FOR THE GOVERNMENT RAILWAYS OF SOUTH AFRICA.

light rails, and where the run is not long enough to require a separate tender. The boiler is of a liberal capacity, the frames and machinery throughout of strong construction, and these locomotives are to be depended upon for hard work and low upkeep. The general dimensions of this type of locomotive are variable, according to the variations in the service for which they are required. In the illustration given they are as follows:

Gauge, 4 ft. 8½ ins.  
Cylinders, 15 ins. by 20 ins.  
Diameter of driving wheels, 42 ins.  
Diameter of truck wheels, 24 ins.  
Rigid wheel-base, 9 ft. 10 ins.  
Total wheel-base, 23 ft.  
Length over bumpers, 28 ft. 10 ins.  
Height from rail to top of stack, 12 ft. 10 ins.  
Weight in working order, 94,000 lbs.  
Weight on driving wheels, 75,000 lbs.  
Water capacity, 1,100 gallons.  
Fuel capacity, coal, 3,000 lbs.  
Fuel capacity, wood, 90 cubic feet.  
Radius of sharpest curves, advised, 160 ft.

Boiler pressure, 180 lbs.  
Traction force, 16,390 lbs.  
Factor of adhesion, 4.56.

Of another distinct type of industrial local locomotives a recent consignment of which were furnished for service in South Africa, as shown in Fig. 2, the type of side tanks are desirable for hot climates because the water does not become heated from the boiler. This is a desirable design for power on light rails or soft roadbeds, with reasonable curves, and also where the length of run does not require a separate tender. It is strongly constructed and is reported to stand well against hard conditions with light renewals. This type is also made in various sizes, the dimensions of the type shown in the illustration is as follows:

Gauge, 3 ft. 6 ins.  
Cylinders, 16 ins. by 20 ins.

Diameter of driving wheels, 40 ins.  
Wheel-base, 11 ft. 10 ins.  
Length over bumpers, 27 ft. 6 ins.  
Weight, rail to top of stack, 13 ft.  
Weight in working order, 96,000 lbs.  
Water capacity, 1,200 gallons.  
Fuel capacity, coal, 3,000 lbs.  
Fuel capacity, wood, 90 cubic feet.  
Boiler pressure, 180 lbs.  
Traction force, 19,580 lbs.  
Factor of adhesion, 4.90.

### Meeting of Erie Officials.

Ever since Mr. William Schlafge became general mechanical superintendent of the Erie Railroad he has promoted the holding of periodical meetings of officials connected with the mechanical and stores department for the investigation and discussion of questions calculated to promote economy of operation. "Come, let us reason together," represents an idea of popular wisdom and the Erie staff meetings are based on that principle and have proved productive of much profit to the railroad company and of instruction to the men taking part in the proceedings.

The meetings are generally attended by about twenty officials and all of them display a warm interest in the subjects presented for investigation. At each meeting a list of subjects to be discussed is provided, each member receiving a copy. At the last meeting held at Meadville, Pa., particulars of 81 subjects were provided and they formed the basis of three days' work. At this meeting General Mechanical Superintendent Schlafge occupied the chair and there were present besides the chairman, Mr. A. G. Trumbull, assistant to general superintendent; Mr. E. S. Fitzsimmons, Mr. Charles James, Mr. J. McMullen, mechanical superintendents; Mr. H. S. Burr, superintendent of stores; Dr. August Sinclair, instructor technical education; Mr. F. S. Breen, mechanical engineer; Mr. W. S. Cozad, superintendent apprentices; Mr. Geo. Eisenhauer, electrical engineer; Mr. T. W. Dow, general air brake inspector; Mr. T. S. Dovey, Mr. Wm. Miller and Mr. J. T. Munroe, shop superintendents; Mr. F. A. Griffin, Mr. C. P. Patrick and Mr. F. N. Graff, special agents; Mr. P. J. O'Dea, general inspector; Mr. A. G. Callahan and Mr. A. Nunn, terminal inspectors.

### The Transandine Railway.

The Transandine Railway was the subject of an able paper by Mr. W. T. Lucy, C.E., before the Mechanical Institute of London recently, dealing with the location and construction of the two railways forming the route between Argentine and Chile. A brief description was given of the four different types of locomotives which were in use at the opening of the Chilean Transandine Railway in 1910, together with a short account of the history of the development of the more powerful engines. The conditions necessary in a combined adhesion and rack locomotive for an 8 per cent. (1 in 12½) gradient are considered in detail, comparisons being made between the Kitson-Meyer and the Esslingen types. The author contends that the plan hitherto generally accepted, of providing a separate frame, suspended on the carrying axles of the main frame, for carry-

ing the rack pinions, is unnecessary, and he gives arguments in support of this. He also disagrees with the traditional method of driving the pinions by means of spring-keys, and advocates solid ones as having given better results. He advocates the flexibility in speed obtained by a direct drive on the pinions, and therefore is opposed to the introduction of gearing.

The eight separate brakes used on the Chilean Transandine Railway are dealt with, the value of the repression brake being particularly noted and modifications described which have added to its efficiency. The band brake, which is a usual feature on rack locomotives, is condemned, and reasons are given for its abolition.

Appendices give particulars of a locomotive proposed for the haulage of trains of 150 tons on the 8 per cent. (1 in 12½) gradient, and a list of the cab fittings used on the Chilean Transandine Railway serves to show the complicated nature of the work.

### Railways Brought the Machine Tool.

A subject that would be interesting to many mechanics would be the history of the development of machine tools. Railroad work did much to develop the machine tool, for when locomotives began to be first used, the mechanics making and repairing the engines were compelled to do most of the work by hand tools.

The famous writer on railway subjects in one of his books says: When we commenced in 1828, there was not a planing machine known; screw cutting and drill presses and shaping machines by power were scarcely thought of. Slide rests were sometimes used, but turning was generally done by the long handled "button head" and "hook tools," and finishing was done by the hand hammer and chisel. "Steam joints were made with a lead ring on a rough surface and packed with rusted iron borings."

Under such circumstances many of the great establishments, such as Baldwin's and Seller's, now holding high rank for the extent and quality of their production, were commenced.

### Simple Test of Coal.

There is a very simple form of test for coal that ought to be known to every one interested in fuel. It is based on the quantity of pure lead that will be released from its oxide by a given weight of carbon. Litharge is oxide of lead and contains 34.5 units of lead to one of oxygen. When finely powdered coal mixed with oxide of lead is heated to the combining temperature, the oxygen of the compound unites with the carbon and leaves the metallic lead. The quantity of lead precipitated gives the means of determin-

ing how much carbon there was in the coal used.

Let a sample of coal be heated with forty times its weight in pure litharge. The weight of the former will give a basis for ascertaining the purity of the coal. The weight of lead will vary from twenty to thirty times the weight of the coal. If the weight of the lead is twenty-five times the weight of the coal employed, the percentage of carbon in the

coal will be about  $\frac{25}{34.5}$ . This is not absolutely correct, but it is near enough for all practical purposes.

### Graphite for Joints.

Put up your pipe joints with graphite; use it on bolts and nuts; cover gaskets with it for hand-hole plates, and use it on all joints and bolts in and around the front-end, and when you want to get the parts down they will be moved without the use of chisel or sledges. If in making pipe joints some of the graphite gets into the pipe, it blows through as easily as oil does. Will not harden into a shot to destroy the efficiency of injection, lubrication and what not. Is the only lubricant that does not burn away and is especially valuable for washout plugs and other boiler joints.

### Railroad Electrification Advocated for Boston.

Two bills for the electrification of railroad lines entering Boston are being considered by the Massachusetts legislature, a hearing being held recently by the Railroad Committee. J. J. Leonard, for the United Improvement Association, Boston, advocated the measures as a means of relief from the smoke nuisance in the suburbs, and to increase service. Attorneys for the Boston & Maine and New York, New Haven & Hartford railroads opposed the bills on account of lack of funds at the present time. The cost of electrification in the metropolitan district is estimated at \$40,000,000.

### Getting Along in the World.

"Yes," boasted the over-dressed individual, "I can make my clothes last. This hat is an example of my thrift. Bought it three years ago, had it blocked twice, and exchanged it last month for a new one in a railway restaurant."

Though thou shouldst be going to live three thousand years and as many times ten thousand years, still remember that no man loses any other life than that which he now lives, nor lives any other than that which he now loses.

# Items of Personal Interest

Mr. G. F. Smith has been appointed master mechanic of the Colorado, Kansas & Oklahoma.

Mr. T. Redmond has been appointed car foreman of the Canadian Northern, with office at Ottawa, Ont.

Mr. P. D. Fitzpatrick has been appointed valuation engineer of the Central Vermont, with office at St. Albans, Vt.

Mr. Thomas Rodger has been appointed superintendent of telegraphs of the Grand Trunk, with headquarters at Montreal, Que.

Mr. D. A. Graham has been appointed resident engineer of the Canadian Northern Pacific, with office at Vancouver, B. C.

Mr. F. G. Lister has been appointed mechanical engineer of the El Paso & Southwestern System, with headquarters at El Paso, Tex.

Mr. Paul Linthicum has been appointed assistant shop superintendent of the Rock Island at Silvis, Ill., succeeding Mr. G. W. Cuyler, transferred.

Mr. A. Taylor has been appointed night locomotive foreman of the Canadian Northern at Winnipeg, Man., succeeding Mr. J. Black, transferred.

Mr. A. Mays has been appointed locomotive foreman of the Canadian Northern at Edmonton, Alta., succeeding Mr. W. M. Armstrong, transferred.

Mr. A. C. Shields has been appointed division engineer of the Missouri division of the Chicago, Rock Island & Pacific, with office at Trenton, Mo.

Mr. G. D. Swingley has been appointed supervisor of bridges and buildings on the San Antonio & Aransas Pass Railway, with office at Yoakum, Tex.

Dr. and Mrs. Angus Sinclair are on their annual visit to the west coast of Florida. They report delightful climatic conditions in the land of flowers.

Mr. C. R. McArthur has been appointed car foreman of the Rock Island, with office at Silvis, Ill., succeeding Mr. S. H. Adams, assigned to other duties.

Mr. T. Hambly has been appointed acting road foreman of locomotives, district No. 1, Lake Superior division, Canadian Pacific, with office at Sudbury, Ont.

Mr. J. Herring has been appointed car foreman of the Canadian Northern, with office at North Battleford, Sask., succeeding Mr. A. H. Sweetman, transferred.

Mr. E. J. Harris has been appointed master mechanic of the Missouri division of the Chicago, Rock Island & Pacific, succeeding Mr. P. Linthicum, transferred.

Mr. I. C. Newmarch has been appointed

superintendent of shops for the New York Central, with office at Collinwood, Ohio, succeeding Mr. R. H. Montgomery, deceased.

Mr. W. H. Strang, formerly road foreman of engines of the Chicago, Indianapolis & Louisville, at Lafayette, Ind., has been appointed general road foreman of engines.

Mr. T. D. Sedwick, formerly chief chemist of the Chicago, Rock Island & Pacific, has been appointed acting engineer of tests, succeeding Mr. F. O. Bunnell, resigned.

Mr. H. B. Kraft, formerly foreman of the steel car shop of the Pennsylvania at Altoona, Pa., has been appointed foreman of the truck shop, succeeding Mr. J. W. Shangler.

Mr. B. E. Lintz has been appointed roundhouse foreman of the Santa Fe, with office at Ash Fork, Ariz., succeeding Mr. D. P. Curts, who has been appointed shop foreman at Gallup, N. M.

Mr. J. Black, formerly assistant locomotive foreman of the Canadian Northern at Kamsack, Sask., has been appointed locomotive foreman, succeeding Mr. L. Vincent, transferred.

Mr. Charles E. Barba, formerly assistant engineer, mechanical department, of the Pennsylvania at Altoona, Pa., has resigned to accept a position with the Midvale Steel & Ordnance Company.

Mr. W. H. Farraday, formerly chief clerk to the vice-president of the Pennsylvania has been appointed assistant purchasing agent, with office at Philadelphia, Pa., succeeding Mr. George H. Crone, resigned.

Mr. F. E. More, formerly motive power inspector of the Pennsylvania Lines West of Pittsburgh, western division, has been appointed assistant road foreman of engines, succeeding Mr. F. E. Wilmore, promoted.

Mr. G. Crawford, formerly fuel engineer of the Chicago, Burlington & Quincy, has been elected secretary and treasurer of the International Railway Fuel Association succeeding Mr. C. Hall, resigned.

Mr. Thomas E. Howley, formerly inspector of locomotive service of the Erie at Port Jervis, N. Y., has been promoted to superintendent of locomotive operation, with office at New York, succeeding Mr. W. C. Hayes, deceased.

Mr. I. Drake, formerly general roundhouse foreman of the Santa Fe at Clovis, N. M., has been appointed master mechanic at Clovis, and Mr. A. H. Reime succeeds Mr. Drake as general roundhouse foreman at Clovis.

Mr. G. W. Conway has been appointed general storekeeper of the Louisville & Nashville, with office at Louisville, Ky., succeeding Mr. S. G. Conner, deceased, and Mr. Edwin Meyers has been appointed assistant general storekeeper.

Mr. I. D. Hines, formerly master mechanic of the Baltimore & Ohio, at Brunswick, Md., has been transferred to Philadelphia, Pa., and Mr. M. E. Mullen, formerly general foreman at Grafton, W. Va., has been appointed to succeed Mr. Hines.

Mr. R. L. Stewart has been appointed mechanical superintendent of the Rock Island, with office at El Paso, Okla., and Mr. L. A. Richardson's jurisdiction was extended to include also the Nebraska & Colorado divisions, with office at Des Moines, Ia.

Mr. J. A. MacRae has been appointed mechanical engineer of the Minneapolis & St. Louis, with headquarters at Minneapolis, Minn., and Mr. J. B. Halliday has been appointed acting master mechanic of the Central and Western divisions, with headquarters at Minneapolis.

Mr. G. H. Langton, formerly master mechanic of the Seaboard Air Line at Raleigh, N. C., has been appointed shop superintendent of the Portsmouth, Va., shops, and Mr. A. C. Adams has been appointed master mechanic of the Virginia division at Raleigh, succeeding Mr. Langton.

Mr. Charles A. Bingham, formerly assistant engineer of motive power of the Philadelphia & Reading, at Reading, Pa., has been appointed mechanical engineer of the Philadelphia & Reading, and subsidiary companies. The position of assistant engineer of motive power has been abolished.

Mr. W. L. Connors, formerly signal supervisor of the Buffalo, Rochester & Pittsburgh at Warsaw, N. Y., has been promoted to assistant signal engineer, with headquarters at Du Bois, Pa., succeeding Mr. L. R. Bryam, and Mr. J. H. Moore, formerly signal supervisor at East Salamanca, N. Y., has been promoted to signal supervisor at Warsaw.

Dr. F. W. Cunningham of Orange, N. J., has resigned his connection with the research and development work of the Newark plant of the General Electric Company to join the Engineering Research Staff of the Powdered Coal Engineering & Equipment Company of Chicago at which point he will be located after March 1st. In his new connection Dr. Cunningham will considerably broaden the field of his activities.

Mr. H. R. Hanlin, general manager of the Dayton and Union Railroad, and the Dayton Union Railway, at Dayton, Ohio,



resigned, effective February 1, to become superintendent of the New York terminal properties of our Company, with headquarters at St. George, Staten Island. Mr. Hanlin will report to W. H. Averell, general manager, who announces in connection with the appointment that the positions of general superintendent and assistant general superintendent will be abolished.

Mr. Thomas Williams, formerly Chief Mechanical Engineer of the Aeromarine Plane and Motor Co., of Avondale, N. J., and a specialist in carburization of fuels, has accepted the position of Chief Consultant of the Board of Engineering Research, Mechanical Applications, of the Powdered Coal Engineering & Equipment Company of Chicago and will direct the research work of that company in the carburization of comminuted fuel and the application of automatic mechanical regulation and controls thereof.

Mr. William W. Mason, who has been connected with the Public Service Commission for the First District of New York since 1908, has been appointed senior electrical engineer for the Interstate Commerce Commission, Central District, with headquarters at Chicago, Ill. In 1899 he took a position with the Boston Elevated Railway, of Boston, Mass., and assisted in installing the multiple-unit system on that road. In 1903 he went to the Pacific coast where he constructed the first third-rail interurban line west of the Mississippi river. After the earthquake in 1906 he returned to the East, entering the employ of the Westinghouse, Church, Kerr & Company, of New York. He supervised for this company all field parties in the appraisal of rolling stock of the electric properties of the New York, New Haven & Hartford Railroad. During the appraisal of the Metropolitan Street Railway, Brooklyn Rapid Transit Company, Coney Island & Brooklyn Railroad, Second Avenue Railroad and the Third Avenue Railroad by the Public Service Commission, Mr. Mason was a member of that body.

Mr. R. L. Wilson, manager of the Railway Division of the Westinghouse Electric & Mfg. Company, East Pittsburgh Works, has been appointed assistant general superintendent looking directly after trades apprentices, employment, working conditions and other matters of a similar nature.

Mr. Wilson was born in Shelbyville, Ind., and is a graduate of Rose Polytechnic Institute of that state. He entered the employ of the Westinghouse Electric & Mfg. Co. in 1893 as a student draftsman, and subsequently became inspector, engineer of construction and later superintendent of construction, at one time being in charge of erection work in the New York district. Later Mr. Wilson was made superintendent of the Railway Division, which position he con-

tinues to hold. He is chairman of the joint committee appointed by the company and the employes for the settlement of differences in opinion arising between the employes and the company, and is also trustee of the Veteran Employes Association of the Westinghouse Electric Company.

---

#### OBITUARY.

##### Alexander Saunders.

The death is announced last month of Mr. Alexander Saunders, for many years president of the D. Saunders Sons Company of Yonkers, N. Y. Mr. Saunders was in his seventy-eighth year, and retained his fine faculties up to the last year of his life. In his chosen vocation of the manufacturer of improved tools for car shops he perfected many improvements, and under his able management the firm grew into much popular favor as makers of fine tools. He had a wide acquaintance among railway men and was highly esteemed.

---

##### G. W. Vaughn.

Major G. W. Vaughn, an eminent railroad engineer, died last month at Leavenworth, Kan., aged 86 years. He was for many years prominently identified in railroad construction work on the principal Western railroads. One of his chief works as engineer was the supervision of grade crossing elimination in the city of Chicago, Ill. At the completion of this important work in 1904, he retired from active work. He was a native of New York State, and went West at an early age.

---

##### Dr. Charles A. Eaton on the Origin of the American Nation.

America is a great and beautiful ideal. Brilliant arguments have been made that America is cosmopolitan, but it is British in essence. America was born in that flowering of British life which followed the discovery of the new world. Men came to these shores impelled by a great passion; haunted by a glorious dream. Somewhere they had caught the divine contagion of freedom and their souls were transfigured by the new vision. They believed in the right of a man to himself and his own soul to his own thought, and his own home to the fruits of his own toil. They stood for the right of a man to govern himself by the ordered processes of law. This was the dream of the Briton. The iron-handed Barons in the meadows of Runnymede wresting from a reluctant King that charter which has become the cornerstone of all progress towards civil freedom, were the spiritual ancestors of America. Wild Scots ever fighting for freedom, signing covenants with their blood, singing the stirring songs of liberty

among their free mountains, these were the fathers of America. The individual believed that he had a right to freedom, to opportunity, to a "place in the sun." He believed in the spiritual dignity, worth and equality of men. He put freedom above life; manhood above money. Much has been built upon this foundation. Much of worth and beauty by Teuton and Latin and Slav, but the organizing principle, the architectonic idea of our national life is Anglo-Saxon, in origin, in temper, in quality and in the method and law by which it became a nation.

---

##### Old Men for Firemen.

A correspondent of mature age who wishes to start a new lease of life as a locomotive fireman writes us denouncing the practice of railroad mechanical officials in refusing to employ men for firemen who are more than twenty-five years of age. He says that no man is at his best until he passes his twenty-fifth birthday.

We believe that young men are preferred as firemen because they are likely to learn the part requiring skill more readily than older men. The argument in hiring young men for firemen are the same as those urged for novices to enter other lines of business. Certainly the railroad companies have the right to establish rules regarding the age at which men will be admitted to enter any kind of employment. From the experience the writer has had with men who succeeded in being started as firemen after they were over twenty-five years of age, convince that the rules favoring the younger men are sensible.

---

##### The New York Central Railroad.

President A. H. Smith, of the New York Central Lines, has blossomed into authorship. His work is briefly and tersely setting forth the history of the New York Central Railroad from 1831 to 1915. As now constituted it represents 186 predecessor companies, and the final consolidation of these companies in December, 1914, created one of the greatest railroad organizations in the United States, and planted an important landmark in the history of railroad transportation. Mr. Smith tells the story as it should be told. Many of the leading railroads have had their biographers or historians and the massive volumes were remarkable for fulness and dullness. Life is too short to read such compilations. Some of them are nearly as bad as government reports, but in the future Mr. Smith's model of brevity and method of telling us all we need to know we trust will be taken as an example by future railroad historians. As a frank, authoritative statement of actual conditions, the booklet is a valuable addition to the railroad literature of our time.

## Memorial Tablet to George Westinghouse in the Reception Rooms of the East Pittsburgh Works of the Westinghouse Electric & Manufacturing Company

The Veteran Employees Association of the Westinghouse Electric & Manufacturing Company, at its annual banquet last month, in Pittsburgh, Pa., presented to the company a fine bronze memorial tablet of the late George Westinghouse, founder of the numerous industries bear-

It bears the inscription, "George Westinghouse, Master Workman, Inventor, Founder, Organizer, 1846-1914." It is placed in the reception room of the East Pittsburgh works of the electric company. The model for this tablet was sculptured by the well-known Chicago

ferent phase of the great inventor's life which has particularly impressed him. The tablet was presented on behalf of the veterans by Charles F. Scott, who, in addition to his duties as consulting engineer, is also professor of electrical engineering, Sheffield Scientific School, Yale University, and was accepted on behalf of the company by Guy E. Tripp, who in accepting the tablet on behalf of the company, said in part: "History is little more than a biography of great men, and admiration and emulation of them is the real foundation of advancing civilization. History has been enriched by the life of George Westinghouse, and if we, his associates, have not received some benefit in our lives, if we have not been encouraged by his example of courageousness, if we have not been incited to new efforts by his perseverance, then we should regret having neglected our opportunities. It was an opportunity to have observed his unfettered methods of work—unfettered because he could labor at details without being swallowed up by them and he could deal comprehensively with the whole without vagueness. He instinctively knew the essential point and swept all other matters aside as of minor importance."

### Spontaneous Combustion.

There is a remarkable tendency observable in tissues and cotton when moistened with oil, to become heated when oxidation sets in, and sad results often follow when the tendency to take fire is neglected. A wad of cotton used for rubbing a painting has been known to take fire when thrown through the air. The waste from vulcanized rubber, when thrown in a damp condition into a pile takes fire spontaneously. Masses of coal stored in yards frequently take fire from spontaneous combustion without any spark of fire being applied to the mass. It is good to know such things and to guard against mysterious fires.

### Government Regulation of Railway Rates.

The MacMillan Company of New York has just published an able work by Professor Meyer which is based on to twelve years' wide experience and study. It presents in detail railway rate regulation in those countries where Professor Meyer has been able to study it personally, and gives the pros and cons which the real student will wish to have placed before him in order that in following Professor Meyer's study of the subject, he may draw his own conclusions in a thoroughly logical and scientific manner. While covering ground familiar chiefly to experts, the book is written in such a way as to be most interesting reading for the average student of transportation problems. Price \$1.50.



MEMORIAL TABLET TO GEORGE WESTINGHOUSE.

ing his name. About 450 veterans were present and the president, I. De Kaiser, made the opening address, and John R. Bonham, who is in charge of the Electrical Division of the Engineering Department, acted as toastmaster.

The memorial tablet is approximately 4 ft. by 3 ft., made of solid cast bronze, and weighs about 300 pounds. It shows a true bas-relief likeness of Mr. Westinghouse taken from one of his best photographic poses, seated in an armchair.

sculptor, Lorado Taft. It was placed in position by Jas. H. Matthews & Co., of Pittsburgh.

Addresses were made by a number of veterans, former associates of Mr. Westinghouse, including E. M. Herr, president; L. A. Osborne, vice-president; N. W. Storer, general engineer; B. Kupferberg, of the storeroom office; Charles F. Scott, consulting engineer; and Guy E. Tripp, chairman of the board of directors. Each speaker referred to some dif-

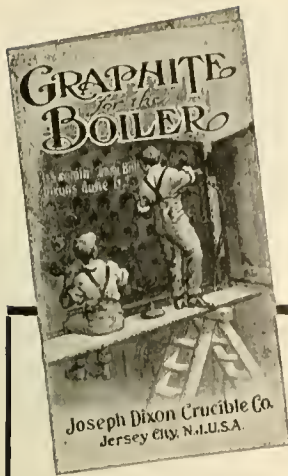

Just send a postal for this booklet

Let Dixon's Flake Boiler Graphite remove scale for you. The explanation of its gentle, mechanical action is fully given in this booklet (No. 69-T), sent free upon request. Do not delay writing for a copy—become acquainted with DIXON'S—"the pioneer boiler graphite."

Made in Jersey City, N. J.,  
by the  
**JOSEPH DIXON  
CRUCIBLE COMPANY**  
Established 1827



T-29

**Railroad Equipment Notes.**

Bessemer & Lake Erie is in the market for 20 locomotives.

Chicago, St. Paul, Minneapolis & Omaha is in the market for 10 freight and 2 passenger locomotives.

Grand Rapids & Indiana is reported as contemplating an expenditure of about \$10,000 for machine tools.

Worth Brothers Co. has ordered two switching (0-6-0) locomotives from the Baldwin Locomotive Works.

The Lake Erie, Franklin & Clarion has ordered 50 steel hopper cars from the Standard Steel Car Company.

Southern Pacific has ordered 20 Mikado (2-8-2) type locomotives from the American Locomotive Company.

The Central of Georgia has ordered 10,000 tons of rail from the Tennessee Coal, Iron & Railroad Company.

The British Government has given the Baldwin Locomotive Works an order for 20 four-wheel tank locomotives.

Atchison, Topeka & Santa Fe will install new machinery in its car repair shed and wheel shop at Argentine, Kan.

The Cuba Railroad has ordered 350 flat, 350 box and 500 cane cars from the American Car & Foundry Company.

The Garden City Western, Kansas City, Mo., has ordered 15 general service cars from the American Car & Foundry Company.

Florida East Coast has placed a large order for frogs, switches and track supplies with the Pennsylvania Steel Company.

The Republic Iron & Steel Company, Youngstown, Ohio, has ordered 2 Mogul type locomotives from the Baldwin Locomotive Works.

Chicago & North Western Railway, reported as considering the purchase of additional locomotives, is in the market for 25 freight, 12 passenger and 28 switching locomotives.

Great Northern is reported actively in the market for steel car axles, cranks, piston rods, shapes, plates, angle bars, bolts and spikes, calling for about 10,000 to 15,000 tons of steel.

Southern Pacific has ordered 50 passenger cars from the Pullman Company. The order includes 10 baggage, 20 combination baggage and mail, 2 combination passenger and baggage cars and 18 coaches.

Cuba Railroad has ordered 25 10-wheel (4-6-0) locomotives from the American Locomotive Company. The cylinders will be 20 by 26 inches, driving wheels 56 inches, total weight in working order 152,000 pounds.

The Lackawanna Steel Company, Lackawanna, N. Y., has ordered 700 50-ton hopper cars from the American Car & Foundry Company and 700 of the same type from the Standard Steel Car Company for its Ellsworth Colliery.

The Detroit Terminal has ordered 3 superheater six-wheel switching locomotives from the American Locomotive Company. These locomotives will have 21 by 28-in. cylinders, 57-in. driving wheels, and a total weight in working order of 172,000 pounds.

Chicago Great Western has placed an order with the Federal Signal Company for 133 Federal type "4"-A signals complete with all other materials required for automatic signal installation and route locking through several mechanical interlocking plants.

The Atchison, Topeka & Santa Fe has ordered 241 tons of steel for a blacksmith shop at Albuquerque, New Mexico, from the Missouri Valley Bridge & Iron Company, and 241 tons of steel for a blacksmith shop at Topeka, Kan., from the Lackawanna Bridge Company.

The Missouri Pacific has ordered from the Federal Signal Company 66 Federal Type "4"-A signals complete with all necessary relays, cable posts, relay boxes, etc., for a signal track automatic signal installation. These signals will be installed between Piedmont, Mo., and Popular Bluff, 39 miles.

The Southern Pacific has ordered 900 50-ton steel frame box cars, 760 40-ton steel frame stock cars, 650 50-ton steel flat cars and 275 flat car bodies from the Ralston Steel Car Company; 1,000 50-ton steel frame box and 250 50-ton all-steel gondola cars from the Haskell & Barker Car Company, and 3 caboose cars from the Mount Vernon Car Manufacturing Company.

The Denver & Salt Lake has ordered 4 Mallet type and 2 Mikado locomotives from the American Locomotive Company. The Mallet type locomotives will have 21 and 33½ by 32-in. cylinders, 55-in. driving wheels and a total weight in working order of 361,000 pounds. The Mikado locomotives will have 26 by 30-in. cylinders, 55-in. driving wheels, and a total weight in working order of 305,000 pounds. All 6 locomotives will be equipped with superheaters.

## Books, Bulletins, Catalogues, Etc.

### New Illustrated Pamphlet on the Electro-Pneumatic Brake for Steam Road Service.

In announcing our publication of a finely illustrated and descriptive pamphlet presenting the complete details of the newly-perfected electro-pneumatic brake for steam railroad service, we would state that our aim has been to place in the hands of railroad men interested in the latest development of the air brake a complete description of the universal valve which is the latest form of operating valve rapidly taking the place of the triple valve in passenger car service. The pamphlet contains finely colored views of the universal valve in all the various positions, the coloring showing the flow of air pressure throughout in the different positions.

The introduction of the electro-pneumatic brake has met with such marked success that its appearance has been hailed as a revelation of the possibilities of electric service, and a constantly increasing number of requests having come to us for full descriptive matter in regard to its construction and operation, the pamphlet has been prepared to meet this demand, and orders are being filled as rapidly as received. A number of the leading railroads have decided to use the appliance, and the Pennsylvania Railroad has already adopted it as the standard brake for passenger cars.

It was our intention to have the pamphlet ready some months ago, but we deemed it proper to wait until the extensive tests were completed, and several minor changes perfected, and the highest authorities now agree that the universal valve is practically complete in its present form, and the accuracy of the matter contained in the pamphlet has been vouched for by them, so that the seal of approval has been placed on our part of the work by all who are interested in the construction and testing of the improved appliance.

In addition to the colored views, there are a number of line drawings of the general arrangement of the brake and wiring diagrams and half-tone illustrations of the brake valve, universal valve and connections between cars. The printed matter embraces a general description of the brake, the construction and operation of the universal valve, the names and duties of the various parts, besides special reference to contingencies that may happen in service.

This valuable publication was written and published under the direct supervision of Mr. George W. Kiehm, Air Brake Editor of RAILWAY AND LOCOMOTIVE ENGINEERING, who has been fortunate in having an extensive experience in oper-

ating and testing the universal valve. All orders for copies of the publication should be sent to our office, 114 Liberty street, New York. The price is fifty cents per copy.

### Report of the Proceedings of the Forty- eighth Annual Convention of the American Master Mechanics' Association.

The report of the meeting of the Master Mechanics' Association, held at Atlantic City last June, has just been issued by the secretary, Joseph W. Taylor, and extends to 736 pages. The illustrations and folders are more than usually numerous and furnish many important details on improved construction. The work bears out what we have previously stated in regard to the association that the various committees work earnestly in securing much valuable information on the various subjects, and the interesting discussions bear out the conclusions arrived at by the committees. Of special importance among the subjects discussed was the recommendation of the Committee on Locomotive Counterbalancing, setting forth very clearly that many of the reciprocating parts of the locomotive should be made much lighter than formerly, on account of the marked improvement in alloy steels; the recommended amount of saving in weight being about one-third, so that the parts referred to might be reduced to 1/240 part of the total weight of the locomotive, instead of 1/160 part, as representing present practice, with the result that more of the weight allowable on the rail would be used in pulling the train. Copies of the report may be had from the secretary.

### Proceedings of the Forty-ninth Annual Convention of the Master Car Builders' Association.

The Proceedings of the Master Car Builders' Association appears in two bulky volumes comprising 1072 pages, with numerous illustrations and folders. As reported in our columns last July, many of the reports presented by the various committees were remarkable for the degree of fulness with which the subjects were treated. These, together with the discussions by the members now appear in complete detail, and the result unquestionably is that a considerable advance has been made toward the standardization and improvement in designs of many of the details of car construction. Many recommendations of much value appear in the reports, an instance being the urgent insistence of the committee on car wheels, that wheels of the recommended size should be used, as the failure of car wheels, especially under refrigerator cars,

# GOLD Car Heating & Lighting Company

Manufacturers of

ELECTRIC,  
STEAM AND  
HOT WATER  
HEATING  
APPARATUS  
FOR RAILWAY CARS  
VENTILATORS  
FOR PASSENGER  
AND REFRIGER-  
ATOR CARS  
ACETYLENE SYSTEM  
OF CAR LIGHTING

Send for circular of our combination PRESSURE AND VAPOR SYSTEM OF CAR HEATING, which system automatically maintains about the same temperature in the car regardless of the outside weather conditions.

Main Office, Whitehall Building  
17 BATTERY PLACE  
NEW YORK

# Hydraulic

**Riveters Fixed and Portable  
Punches, Shears,  
Presses, Lifts, Cranes  
and Accumulators.**

**Matthews' Fire Hydrants,  
Eddy Valves  
Valve Indicator Posts.**

The Camden High-Pressure Valves.

## Cast Iron Pipe

**R. D. Wood & Company**  
Engineers, Iron  
Founders, Machinists.

100 Chestnut St., Philadelphia, Pa.

## Nichols Transfer Tables Turntable Tractors

GEO. P. NICHOLS & BRO.  
1090 Old Colony Bldg. CHICAGO

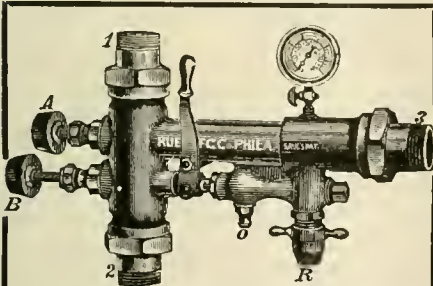

### NOW IS THE TIME to install a Rue Boiler Washer and Tester,

For you will need it when cold weather comes. It will wash out, test and fill your boiler, all with hot water, and have it ready for use in one hour.

THINK IT OVER.  
Catalog on Boiler Washers A-5.  
Catalog on Injectors B-5.

**Rue Manufacturing Co.,**  
228 CHERRY STREET  
Philadelphia, Pa.  
Manufacturers of Injectors, Ejectors,  
Boiler Washers and Testers, Boiler Checks,  
Check Valves.

were out of all proportion to the service. The failures were chiefly under cars of a gross weight of 105,000 pounds or more, which weight is considerably in excess of that supposed to be carried by the ordinary 625-pound type of car wheel, of which type as much as 63 per cent. were found among all the car wheels reported cracked. Applications for copies of the report should be made to the Secretary, Joseph W. Taylor, Karpen Building, Chicago, Ill.

### The Pennsylvania Keeps Up the Good Work About the Smoke Nuisance.

It is always gratifying to us in our Editorial capacity to see our comments quoted in other quarters, and among the most recent and most popular manifestation of our readers knowing a good thing when they see it is the issuance of a special booklet issued by the Pennsylvania Railroad Company containing our comments on the result of the Committee's work on the Chicago smoke abatement question. The voluminous report of the Committee whose investigations were under the direction of Professor William F. M. Goss, Dean of the College of Engineering, University of Illinois, was much discussed both by the engineering press as well as by the daily press, but the editors seemed to content themselves with copious extracts from the report, which were all good enough in their easy way, but were deficient in that digestive appliance of the thought which should be given to an important work. This, without boasting, we think, is the cause that induced the Publicity Department of the Pennsylvania Railroad to make the special use of our comments on the question referred to, and which appeared in our January issue. We learn that the booklet has already had an immense circulation running into the hundreds of thousands, and the railroad has acted wisely as there are many other localities besides Chicago where the average citizen requires enlightenment as to the limited contribution of atmospheric pollution caused by the modern locomotive. As we already stated, and as is borne out by the admirable report, the nuisance caused by locomotive smoke is in reality neither here nor there.

### Oxy-Acetylene Welding and Cutting.

Frederick J. Drake & Company, publishers, Chicago, Ill., have just issued a new book of 216 pages, with illustrations. The author, Harold P. Manly, chief engineer of the American Bureau of Engineering, brings to his task a thorough knowledge of the various processes of welding and cutting, and the book has the particular merit of beginning at the beginning, by describing the uses and characteristics of the various metals, and

also the production, handling and use of the gases and other materials, and the tools and accessories for the production and handling of these materials. The practical nature of the book will be found to be admirably suited to all who are engaged in the trade to which it refers. The instructions are of the clearest, and have been arranged to form rules which are placed in the order of their use during the work described, and the work has been divided in such a way that the desired information may be readily found without the necessity of spending time in other fields. The book is sure to meet with popular favor. The price of the book in cloth binding is \$1.00, leather \$1.50.

### One Hundred Years of the Locomotive.

The Erie Railroad Company has issued an elegant, illuminated booklet commemoration of one hundred years of the locomotive. The work is full of interesting historical matter and every page has an illustration of a locomotive from Stephenson's first experiment up to and including the triplex compound on the Erie, which, as is well known, is the largest and most powerful engine in the world. Every page of the booklet is interesting and the old prints and unusual photographs have been gotten together and carefully selected and finely reproduced with a view to form at once a condensed history of the development of the locomotive as well as a fitting memento of the first century in which steam has been used in locomotion. We understand that copies of the unique publication may be had from Mr. R. H. Wallace, general passenger agent, New York.

### Drill Chips

All shop mechanics and especially shop foremen must be interested in drills. The drill is a very important member of a machine shop equipment, but its work properly performed is highly important and deserves fostering care. Some people think that they know everything about drills, but if they will secure possession of the January number of "Drill Chips," published by the Cleveland Twist Drill Company, of Cleveland, O., and read it carefully they will conclude that they had many valuable facts to learn about drills. That is, if they will make proper use of the pamphlet by reading it carefully three or four times. The Cleveland Twist Drill Company gladly send you the "Chips" if you mention you are taking our advice in asking for it. Be sure to read it carefully.

### Staybolts.

The monthly digest issued by the Flannery Bolt Company, Pittsburgh, Pa., is always of interest as showing some new



## ASHTON POP VALVES AND GAGES

The Quality Goods That Last

The Ashton Valve Co.  
271 Franklin Street, Boston, Mass.  
No. 174 Market St., Chicago, Ill.

phase on the development of their popular products or other matter appertaining to the same. In the February issue there is a continuation of a scholarly essay on the different types of staybolts with illustrations of the various forms of staybolts, and it is remarkable that while little more than ten years have elapsed since the flexible staybolt came into general use it had been in one form or another nearly forty years making its way, so to speak, until Mr. John B. Tate obtained a patent in 1906, embodying for the first time the idea of using a round-headed staybolt, in the three-piece type with outside cap connection. This design was favorably accepted from the start, and its modifications have been necessary to suit the requirements of all types of boilers.

#### Recent Westinghouse Publications.

Westinghouse railway motors Nos. 306-V, 307-V, 333-V and 547-A are thoroughly described and illustrated in a series of leaflets just issued by the Westinghouse Electric & Mfg. Co., Nos. 3837, 3765, 3833 and 3835 respectively. The particular characteristics of these motors, together with detail views of construction, and operating curves are given. Alternating current magnet switches, type F, for industrial service are described in leaflet No. 3551-A. These switches have been designed with a view to fulfill the severest requirements of industrial service, and their details of construction and operating characteristics are given in the leaflets together with illustrations of them mounted on panels. Alternating current low-voltage switches, type EA, are described and illustrated in leaflet 3849. Diagrams of typical connections are given and the construction of the board thoroughly described.

#### International Engineering Congress, 1915.

The committee of management, International Engineering Congress, 1915, announces that the volume on Mechanical Engineering is ready for distribution and the members who have subscribed to this volume will soon receive it.

The other volumes will be issued as rapidly as possible. Owing to the large amount of material to be reprinted, and the thousands of copies to be bound, the work cannot be carried on with greater speed. However, it is hoped that within two months the entire set will be completed.

Members who did not send in their final selections may be disappointed in not securing all the volumes they might have had in mind, and at this date the Committee has decided to close the lists for certain volumes which have been sent to the press. It may be possible to supply members who would apply at this late hour with copies of volumes which have not gone to press.

#### A Rogue Overreaches Himself.

When a smart rogue having property adjoining a railroad sets himself to manufacture claims for damages against the corporation for damages he rarely fails to succeed in obtaining money unjustly. This is a little more certain when the railroad is suburban and has the reputation of being controlled by one of the Money Barons. The men who work up claims for damages against railroad companies sometimes, however, overreach themselves even when the would-be victim is the Manhattan Elevated Railroad. The particulars of a case in point reached us a short time ago. Eugene Nathan, a property owner on one of the New York avenues brought suit against the Manhattan Elevated Railroad for damages to his property adjoining one of the elevated railroad stations. It was alleged to obstruct the light from a corner building and to greatly depreciate the value of a saloon on the ground floor. The jury found a case for the plaintiff and required the company to pay heavy damages or move the station. The company decided to move their station and now the lessee of the saloon is suing the proprietor for \$10,000 damages caused by the loss of custom caused by the station being moved. He will try some other business.

#### A Tramp Fireman.

We have seen the time when railroad companies hired tramp firemen to tide over an emergency of rush business. A fireman of the tramp genus was assigned to Ed. Mahogany. Ed's tramp was a conversationalist and wished to spend most of the time talking to the engineer, neglecting the fire so the engine was steaming badly.

"If Tom Jarvis of the Big Three were running this scrap-heap," said Mr. Tramp, "there was never no busted kettle got away with Tom. Why, pard, Tom would make an engine steam when the boiler was so full of mud and scale that ten buckets of water would choke her up to the whistle."

"Won't you add two buckets to that and make it an even dozen?"

"Nary a bucket."

"Tom was up to all kinds of tricks. No blooming engine would refuse to steam when Tom was at the throttle. If Tom was on this bullgine I bet she would steam."

"Well, I can make this engine steam with very little change."

"Is that so, pard? I wish you would make the change right away."

"Wait till we get in and I shall have another fireman."

She steamed o. k. next trip.

Man's greatest friend is his knowledge. His greatest enemy is his ignorance.

## Locomotive Engine Running and Management

By ANGUS SINCLAIR

This popular book has been a **RELIABLE REFERENCE** and comfortable unfailing **POCKET EDITION**.

PRICE, \$2.00

**ANGUS SINCLAIR CO.**

114 Liberty St., New York

## STEEL STAMPS

**INSPECTORS HAMMERS**  
Hand Cut **STEEL LETTERS & FIGURES**  
**LATHE TOOLS, TIME CHECKS,**  
Noble & Westbrook Mfg. Co.  
9 ASYLUM ST. HARTFORD, CONN.

**THE ARMSTRONG IMPROVED  
PACKER RATCHET DRILLS**  
Are **ALL STEEL**  
and  
**Hardened All Over**  
Will outwear two of the soft kind.  
We make all kinds—all sizes.  
Do you want a catalog?



**ARMSTRONG BROS. TOOL CO.**  
"The Tool Holder People."  
112 N. FRANCISCO AVE., CHICAGO, ILL.

NEVER SHRINKS OR DETERIORATES



**ESPECIALLY PREPARED  
FOR THE ENGINEER**

<b>WORKS EQUALLY WELL ON HOT and COLD SURFACES</b>	<b>CLEANS POLISHES and PRESERVES ALL KINDS OF METALS</b>
--	--

**GEO. WM. HOFFMAN CO.**

Indianapolis  
New York Chicago San Francisco  
Send for **FREE Sample**

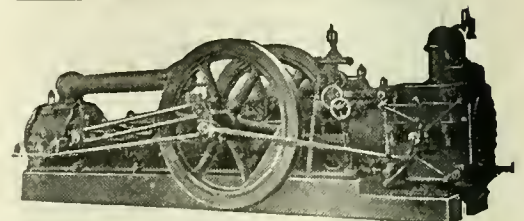

**The Norwalk Iron Works Co.**

**SOUTH NORWALK, CONN.**

**Makers of Air and Gas Compressors  
For All Purposes**

Send for Catalog

# Railway AND Locomotive Engineering

A Practical Journal of Motive Power, Rolling Stock and Appliances

Vol. XXIX.

114 Liberty Street, New York, April, 1916.

No. 4

## Early Engineering Triumphs in New England

Records of Tunnels, Curves and Grades Not Yet Surpassed

In the colossal construction work that has been going on in several of the leading railroads recently there is a tendency to look proudly upon the achievements as if nothing of the kind had previously been accomplished, and as if the present century with its amazing facilities had

completed that are not yet surpassed, or at least not to any great extent.

The earliest and many of the cleverest engineering works were done on what is now a part of the Boston & Maine railroad. The railroad running to the summit of Mount Washington was the pioneer in

out of the spectral whiteness mountain peaks are rising like emerald isles in a sea of amethyst. The little train comes like a messenger from the nether world, and out of the weird wonderland we feel that we are in touch with the earth again.

Great things were done in the atmo-



MOUNT WASHINGTON RAILWAY FROM THE BASE STATION.

suddenly become the period of monumental mechanical achievements. This is a gross error, and; letting the Pyramids of Egypt or the Colossus of Rhodes or the Hanging Gardens of Babylon remain in the dim background of antiquity, we must admit that even in the last century many feats of railroad construction were ac-

complished that are not yet surpassed, and it is a strange sight in the dawn of a summer's morning to see the miniature train coming out of the white clouds that envelop the dark valleys beneath, and slowly but surely rising into the upper regions already glittering in the golden glow of sunshine, while here and there

sphere of New England enterprise forty or fifty years ago and are still being done. Among these the Hoosac Tunnel through the Berkshire Hills on the Boston & Albany railroad is an enduring monument that has stood for over forty years without a rival in America. With its brick archway of five miles, it is now being sur-

passed by the tunnel through the Selkirk Mountains, which is about being completed on the Canadian Pacific, and which extends to about six miles of a steel and concrete and natural rock construction, but it is doubtful if it has been as difficult in construction as the older tunnel, whose features have been so frequently described that we need not dwell upon them at this time. There were other engineering feats in construction in relation to the tunnel which, however, we are apt to forget, and which may be interesting to recall.

Among these what is known as the "Horse Shoe Curve" at Beaver Island, which is situated about three miles east of the Hoosac Tunnel, may be recalled. It was a very difficult feat of engineering construction. The curve was built in order to save tunneling through a 1,500-foot mountain. On the other side of the track is the Deerfield River, which follows the track in its winding course. Because of natural conditions the rock at this particular point is very hard and plentiful and this made the work so much more difficult. The track is laid to a 40 degrees and 58 minutes curve, and the elevation of the outer rail is about  $7\frac{1}{2}$  inches. The grade is about 17 feet to the mile. The track construction of the curve provides for unusual smoothness in riding by the use of frictionless rail. This rail is used on the inside of a curve and has a narrower head than the outer rail, allowing wheels to accomplish the necessary slip on the curve with reduced resistance. It

1876; that is, until the Hoosac tunnel was completed. It was necessary to change the bed of the Deerfield River in constructing the curve and the rock and dirt

present day accomplishments, but it must be remembered that it was built in 1872, when engineering was not developed as it is today.

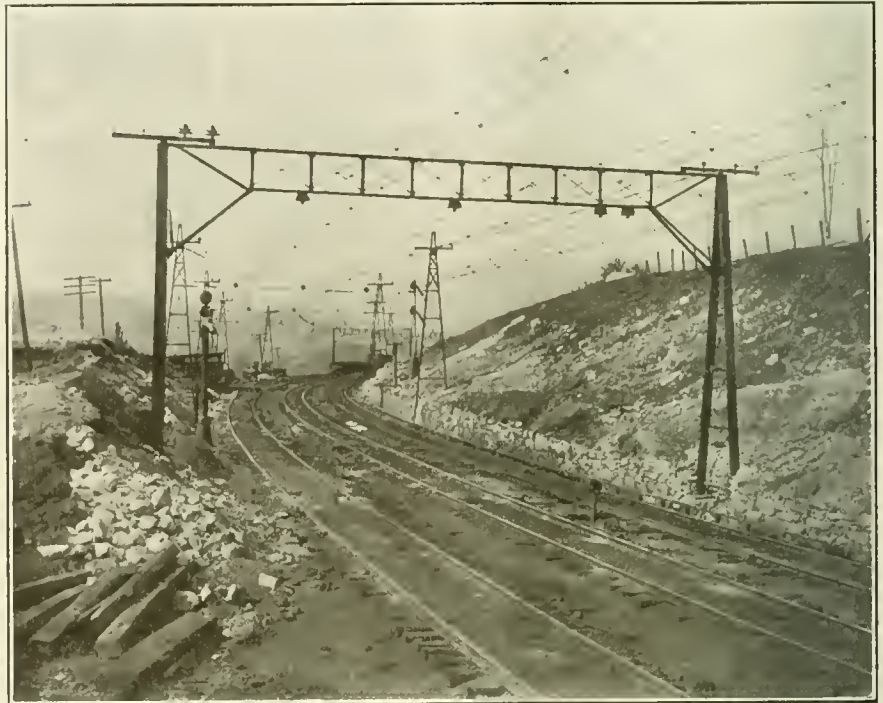

LOOKING FROM WEST PORTAL SHOWING CATENARY SYSTEM.

excavated from the Hoosac tunnel was used for grading and filling in. The curve was very well built because there has never been an accident at this point

It might be interesting to remind many of our readers that the construction of the Hoosac tunnel was begun in 1851 and completed in 1875. The total length is 25,031 feet. The size of the central air shaft is 15 feet by 27 feet. The west shaft measures 10 feet by 14 feet. These shafts effectively aid in the circulation of the atmosphere in the tunnel. Over two million tons of rock were excavated in the operation. The cost of construction exceeded \$16,000,000.

#### London Subways.

London is underrun by a network of subways, or tubes, to use the British name for an underground line. These roads have been constructed and are still owned and operated by wholly or partly independent companies.

Thus there is the Metropolitan line (the old Underground), seventy-one miles in length; the Metropolitan District line, twenty-eight miles in length; the Great Northern and Piccadilly line, nine and a quarter miles in length, which is a double tunnel worked by electric motor power; the Baker street and Waterloo line, nine and a half miles in length, which was originally one of Whitaker Wright's enterprises; the Charing Cross, Euston and Hampstead line, about eight miles in length; the Central London line, six and a half miles in length, which consists of two separate parallel tunnels worked by electric motor power on the multiple unit system; the Waterloo and City line, about



EAST PORTAL OF HOOSAC TUNNEL.

saves rails from considerable wear and the locomotives from considerable work.

The curve was built about 1872 and, was not used to operate trains over until

from the time of its construction even to the present day. Of course, this cannot justly be called a spectacular engineering feat when compared with some of the



two miles in length; the Great Northern and City line, from Finsbury Park to Moorgate street, about three and one-half miles in length, and the City and South London line, from Clapham Common to the north end of City road, Islington, with an authorized mileage of twelve and one-half miles, something over half of which is in operation.

These lines cross and intersect at various points, making it possible by transfers to go almost anywhere underground. The total mileage—constructed, authorized and projected—is 145½ miles, and the total authorized capital of the nine existing companies is £61,553,996.

#### Transportation Congestion in the East.

The *Journal of Commerce* of New York is engaged in an honest endeavor to enlighten the Interstate Commerce Commission and the general public on the congested state of the Eastern railroads. In a recent issue of the *Journal* they set forth the situation very clearly by stating that there is need of patience and mutual consideration in trying to solve the problem of relief, and of co-operation in the effort to work it out to practical results. In this the commission may be of service in bringing the conflicting parties together for a hearing of their complaints and for an exchange of practical suggestions. There is little to be gained by laying stress upon the inadequacy of the means of transportation and of terminal, warehouse and transfer facilities. The situation, as everybody knows, is not only exceptional, but absolutely unprecedented. The railroad companies could not be expected to be prepared for it, for the necessity could not be foreseen. Besides, they were greatly hampered in all their efforts to expand facilities on their lines and at terminals by the restriction put upon their earnings and the accumulation of surplus funds, which impaired their credit for raising new capital.

#### Safety Award.

The gold medal presented by the Travelers Insurance Company each year to the American employer who has done the most during the year to safeguard his employees and the public was given this year to the Hudson and Manhattan Railroad Company. The presentation was made at the annual dinner of the American Museum of Safety recently after a jury of award named by the museum had chosen the railroad to receive the medal "for achievement in accident prevention among its personnel and for promoting safety for the traveling public." The Travelers, though providing the medal, refrains from any part in the awarding of it. The Hudson and Manhattan Railroad Company is better known as the Hudson Tubes, the celebrated twin tunnels built by Mr. William G. McAdoo, now Secretary of the Treasury,

and Mr. Walter G. Oakman, with the financial backing of Mr. Pliny and Mr. Wilbur C. Fisk and the engineering skill of Mr. Charles M. Jacobs and Mr. J. Vipond Davies.

#### The Length of the Pennsylvania.

If the Pennsylvania Railroad System could take up all of its tracks and relay them in a single line, it would have enough to build a standard gauge railroad around the world and double track it from New York to Kansas City. The annual Record of Transportation Lines which has just been issued shows that the trains of this railroad system are now being operated daily over 26,705 miles of track, which gridiron thirteen states and the District of Columbia. The exact length of all the railroad lines in the Pennsylvania System, whether single, double, triple or quadruple tracked, is shown by the Record to be 11,823 miles. Of these lines, 3,761 miles have two or more tracks, 828 miles have three tracks and 635 miles have four tracks. In addition, there are 9,656 miles of track in the sidings owned by the railroad. This excludes the thousands of connecting sidings owned by industrial and other plants.

#### American Locomotives Please New Zealand.

It is stated on reliable authority that the big railway engines imported from the United States by the New Zealand Government last year have done more than come up to expectations. At the time of the order being placed with the Baldwin Locomotive Company some protests were made in Parliament against the giving of orders for railway engines to countries not part of the British Empire, but the fact was shown that the engines were urgently required and that Great Britain could not supply them as quickly as the United States could. The locomotives are now at work on the lines of this Commonwealth and their hauling capacity is exciting the admiration of experts. A remarkably fine effort over hilly country was recorded a few weeks ago, when one of these engines hauled 275 tons from Wellington to Palmerston North (89 miles) without having to replenish either water or coal supplies.

#### Safety First on the Baltimore & Ohio.

At the Safety First exhibit of the National Museum of Safety, which will be held in New York the week of April 17, the Baltimore & Ohio Railroad will install an exhibit which will far surpass its display that received a grand prize at the last congress.

Bringing out the historical facts that America's first railroad, was the first to adopt so many of the refinements of transportation service, the first to orga-

nize a department of safety and enlist its employes in a systematic campaign of protection, the space which the pioneer road will use this year will be double the expanse of its grand prize installation.

President Willard's memorable statement that he considers "Safety First" above everything else" in importance in railroad operation will be carried out in the scheme covering the company's exhibit in Grand Central Palace this year.

#### Model Restaurants on the New York New Haven and Hartford.

Recently the New York, New Haven and Hartford took over the management of the restaurants in the stations at New Haven and Providence, and on December 1 the restaurant in the new station at Hartford was opened. The company also operates the restaurants at Waterbury and Willimantic stations and a hotel at Midway, Conn., for its employes. Several changes are being made and more being considered in the restaurants at New Haven and Providence. The standard of cleanliness and sanitary excellence attained at Bridgeport will be maintained at the new restaurants. The local restaurants in the stations named buy their supplies from local merchants.

#### Safety Record of the Illinois Central Railroad.

The management of the Illinois Central Railroad has announced that in the sixty years ended December 1 the Chicago suburban service of that company has been operated without loss of a life in passenger train accidents. The road handles, in that service, 50,000 passengers daily and operates 300 trains. For the calendar year ended December 31 the Illinois Central on its entire system handled 26,019,820 passengers without the loss of a life in passenger train accidents. This is the third consecutive year that the company has had a clear record in this respect, and in this time 81,080,541 passengers have been transported.

#### Railroad Men's Pay.

Official reports to the Interstate Commerce Commission and evidence presented in the recent arbitrations in the east and west are said by the publicity bureau of the railroads to show that the actual annual earnings of men in the train service, who constitute 18 per cent. of the total number of railway employes, are as follows: Engineers, \$1,760; conductors, \$1,520; firemen, \$1,030; trainmen, \$1,020; average of all men in the train service, \$1,240.

On the other hand, the average earnings of all other railroad employes (including the officers), who constitute 82 per cent. of the number of those in railway employment, is about \$700 per year

## Baldwin Locomotive Works Industrial Locomotives for the Worth Brothers Co., and the Youngstown Sheet & Tube Co.

The motive power requirements of industrial railways are probably quite as diversified as those of trunk lines. Not only are a large number of different types of locomotives used in this kind of work, but each type includes a wide variety in style and size. The reason for this is, that industrial locomotives are required to meet such a wide range of operating conditions. Clearance limits are frequently restricted, tracks are often light and special equipment is required; industrial railways are built to all gauges, from two feet, or even less, to standard; and other factors are usually present, which must be considered when design-

small, thus permitting the boiler to be set low, and keeping the height over all within the specified limits. The locomotive is a coal burner, and the fuel is carried in a box, placed on the left side of the cab. The latter is of steel, and is as large as clearance limits will permit. The water supply is carried in two side tanks, which are designed to fit snugly within the overall dimensions. The steam distribution is controlled by balanced slide valves, and the Stephenson link motion is used. A steam brake is applied, and the draw-heads are of the single pocket type. The leading dimensions follow:

Cylinders, 14 x 16 ins.

utilized to the best possible advantage.

This locomotive will operate under conditions approximating those found in railroad yards and terminals, and is representative of a type extensively used in such service. It uses saturated steam, and is equipped with balanced slide valves and Stephenson link motion. The main rod is connected to the third pair of driving-wheels. Cast steel is used for the wheel centers and boxes. The boiler is of the straight top type, with a long firebox placed above the frames. The cab is of steel, with large side windows and roomy deck. The tank has a straight top, but is comparatively long and low, thus giving



FOUR-COUPLED SWITCHER FOR THE WORTH BROTHERS COMPANY.

ing the locomotives. These engines are often required to remain almost continuously in service with a minimum amount of attention and repairs; hence strong, simple designs with accessible parts, are to be preferred.

The accompanying illustrations represent two locomotives, recently built by The Baldwin Locomotive Works for service in and about steel plants. The four-coupled switcher for Worth Brothers Co. is one of three, built for a track gauge of 2 ft. 6 ins. The height and width limits are 7 ft. 9 ins. and 6 ft. 8 ins., respectively. With these limitations an effective design of locomotive has been worked out, developing a tractive force of 13,300 pounds, and weighing 57,600 pounds. As the wheel-base is short, the locomotive can easily traverse sharp curves.

For an engine of this capacity, the piston stroke is short and the driving-wheels

Boiler, diameter, 44 ins.  
Steam pressure, 165 lbs.  
Firebox, length, 43 11/16 ins.; width, 33 3/8 ins.  
Tubes, number, 110; diameter, 2 ins.; length, 9 ft. 3 ins.  
Heating surface, firebox, 50 sq. ft.; tubes, 528 sq. ft.; total, 578 sq. ft.  
Grate area, 10.1 sq. ft.  
Driving-wheels, diameter, 33 ins.  
Journals, 7 x 8 ins.  
Wheel-base, 5 ft. 6 ins.  
Tank capacity, 800 gals.  
Fuel capacity, 700 lbs.  
Weight, total engine, 57,600 lbs.

The locomotive for the Youngstown Sheet & Tube Co. is of the six-coupled type, with separate tender; and is one of two, built for heavy switching service. It weighs 150,100 pounds, and exerts a tractive force of 38,500 pounds. The ratio of adhesion is thus 3.9 and the weight is

the engineman a good view when backing up.

Further particulars of this locomotive are as follows:

Cylinders, 22 x 26 ins.  
Boiler, diameter, 74 ins.  
Firebox, length, 120 7/8 ins.; width, 42 ins.  
Tubes, number, 335; diameter, 2 ins.; length, 10 ft. 6 ins.  
Heating surface, firebox, 185 sq. ft.; tubes, 1,827 sq. ft.; total, 2,012 sq. ft.  
Grate area, 35 sq. ft.  
Driving-wheels, diameter, 50 ins.  
Journals, 9 x 12 ins.  
Wheel-base, total engine, 11 ft.; total engine and tender, 44 ft.  
Weight, total engine, 150,100 lbs.; total engine and tender, 240,000 lbs.  
Tank capacity, 4,500 gals.  
Fuel capacity, 12,000 lbs.

**Trying to Prevent Cylinder Condensation.**

No steam engine has the cylinders so badly exposed to cooling influences as locomotives; yet every attempt made to keep the cylinders of locomotives to nearly the temperature of the entering steam, produces no economy worth mentioning. The writer has been a firm believer in trying to keep locomotive cylinders hot and has taken part in experiments conducted for that purpose, but they were all failures.

One of the most exhaustive series of experiments ever tried to conserve the heat in locomotives was carried out by George W. Richardson, inventor of the Consolidation safety valve, and F. F. Hemenway, the well known authority on the Steam Engine Indicator. They were given the use of a locomotive by one of our leading railroads and experimented for several weeks. They ran a current of hot air from

would steam freely, while another would scarcely make steam enough to get over the road. All this was popularly supposed to be the case while the parts of the engines were precisely of the same dimensions. The liberal introduction of the steam engine indicator exploded many of the old fallacies and taught engineers and machinists an applied lesson on the principle that there is no effect without a cause. A few men still stick to the old prejudice that the performance of two engines differ from no particular cause, but such views are getting scarce.

In the days when the mystery theories held full sway, the engine of a river steamer began to work very unsatisfactorily. The engineer could not make out what was the matter, so he consulted the best mechanical talent about Burlington. Defective piston rings were blamed for the trouble and new rings were put in, but the engine was no better. A variety of

tives you frequently publish particulars of the traction power but never a word about the horse power. As the standard measure of work is horse power, I should like you to give the horse power of a locomotive with cylinders 20 x 30 inches, driving wheels 60 inches diameter and carrying boiler pressure of 200 pounds to the square inch."

The horse power developed by a locomotive cannot be shown without the average cylinder pressure, which is generally found by the use of the steam engine indicated diagrams. As we have no means of telling the average steam pressure of the engine mentioned by our correspondent we will give the horse power of an engine running the Empire State Express of which the writer took indicator diagrams several years ago.

The engine had cylinders 19 x 24 inches and driving wheels 78 inches diameter. A representative indicator diagram showed



HEAVY SIX-COUPLED SWITCHER FOR THE YOUNGSTOWN SHEET & TUBE COMPANY.

the smoke box around the cylinders maintaining a temperature ranging from 400° to 600° Fah., which ought to have been sufficient to slightly superheat the working steam. Very close record was kept of the water and fuel used. The investigators were astonished to find that no steam saving was effected. The engine was tried without the cylinder heating appliances being in use and exact account of the coal used recorded; then the test with the cylinder heater put into operation and no saving of coal resulted.

**Mysteries About Steam Engines.**

Only a few years ago there used to be much talk among engineers and machinists about the mysterious difference in the working of engines that were built exactly alike. In stationary engines and marine practice, it was often said that no two engines were alike in point of economy, and with locomotives one engine would be smart and the other loggy—one

other changes were recommended and carried out, but the engine began steadily to grow worse and caused much delay in the movement of the boat.

When the owners were thinking of withdrawing the boat, a young engineer who believed there was close connection between cause and effect, happened to be a passenger. He listened to the engine working and expressed the opinion that the exhaust steam was getting choked somewhere. The engineer of the boat insisted that the exhaust was perfectly free, but the other held to his opinion and it led to a thorough examination. It was then found that the pipe of a heater through which the steam passed had collapsed, nearly closing the exhaust passage. When that defect was remedied there was no more trouble with the engine.

**Horsepower of Locomotives.**

One of our correspondents writes: "In your numerous illustrations of locomo-

mean effective pressure of 53.7 pounds per square inch when running 60 miles an hour. The horse power is distributed as follows:

283,529.4 square inches piston area
53.7 pounds M. E. pressure
-----
15,225.5 pressure on one piston
2 pistons
-----
30,451 pounds pressure transmitted from both cylinders
4 feet piston travel in each revolution
-----
121,804
260 revolutions per minute
-----

$31,669,040 \div 33,000 = 959$  horse power.

As most of our readers are aware 33,000 pounds raised one foot per minute represent one horse power.

# Passenger Car Brake Design

## Cars of Certain Weight Should Have a Certain Braking Ratio

By **WALTER V. TURNER**, Assistant Manager Westinghouse Air Brake Co.

In a previous article on this subject of passenger car brakes an effort was made to point out that in equipping a car with an air brake a base for the design must be determined upon, that is, whether some braking ratio is to be arbitrarily chosen, in which the factor of retardation may be what it will or some specified rate of retardation must be fixed upon as the base for the installation and in the latter case the braking ratio can only be determined after many other factors are known.

In the event of the arbitrarily chosen braking ratio, we must consider, a car of known weight, the braking ratio to be employed, then it is necessary to fix upon values for, the range of flexibility, that is, the decrease in auxiliary reservoir pressure to be permitted before the braking ratio is realized, then, shoe clearance, brake piston travel, the cylinder pressure from which the braking ratio is to be obtained, the fiber stresses to be permitted and if the emergency braking ratio is to be greater than that for service, this must be considered in quantity.

These are thought to be all of the necessary factors or absolute values involved in a brake "lay out" where the braking ratio is specified, but there are certain other values which must be known, for instance, the pressure that must be carried, the auxiliary reservoir volume required, the leverage ratio, the size of the brake cylinder and the size of the brake levers. These, however, are all contingent factors or derived values, and must be obtained from others. In other words, they can not be arbitrarily determined, or fixed upon as can all of the preceding fundamental elements. To specify them without deriving them, would be an unwise risk, as the result would probably be the expression of contradictory or inconsistent values, and we submit the following (which makes evident how the derived values are secured from the fundamental values) in proof of this.

The car weight times the braking ratio specified gives the total shoe pressure.

The piston travel divided by the shoe clearance gives the leverage ratio.

The total shoe pressure divided by the leverage ratio will give the total cylinder pressure required.

The total cylinder pressure divided by the unit cylinder pressure will give the area of the piston, which fixes the size of the cylinder.

The volume of the cylinder multiplied by the unit cylinder pressure and divided by the range of flexibility will give the volume of the auxiliary reservoir and this

fixes the size of the auxiliary reservoir.

The unit cylinder pressure plus the range of flexibility will give the necessary auxiliary reservoir pressure which fixes the brake pipe pressure to be carried.

The total cylinder pressure with the total shoe pressure and the fiber stresses to be permitted gives all the necessary information that is required to design the foundation brake gear, the particular form which this shall take depending upon car and truck design and the designers preference. (It is my personal judgment, however, that only a "clasp brake gear" should be employed for modern heavy cars. I have had one or two experiences where the very best air brake mechanism was made very ineffective by an inefficient brake gear.)

If the brake is a duplicate brake, that is, having a service braking ratio and an emergency braking ratio, the size or strength of the foundation brake gear must be based upon the maximum total cylinder pressure.

It will be seen that not one of these eight values can be included among what we have called the fundamental elements, and further, and even more important, not one of them can be arbitrarily chosen, but must follow in the same manner that four follows the adding of two and two if we are to have a harmonious and consistent brake, and to avoid this being dismissed with the assertion that the ideal is not attainable, I will state that by harmonious and consistent, I mean a practical brake.

All the inconsistencies that exist in brake design and installation today are due to the non-observance of these relationships, that is, one or more has been changed without changing the whole, and this cannot be done if the design is to contain but one set of physical dimensions. Remember the assertion is made that it cannot be done if a practical brake is to be had—the answer will be, that it is done. This, we admit, but with chaos and controversy as the inevitable result.

Then follows the next statement of, I don't know, things are not so bad, and certainly better than if we had no brake at all. Admitted again, but with the question that why it is as bad as it is, when is it far easier and much more profitable to all concerned to have the design as it should be?

It seems to the writer that the chief reason why the idea prevails among so many that the derived factors or values can be juggled arbitrarily, as can the fundamental or absolute values, is that, previously a distinction has not been emphati-

cally drawn between them, showing that they will no more mix than will oil and water.

Another reason is that a number of the factors have at some time been fixed by the manufacturers, or some other authority, and the reason for this largely forgotten, or an analysis is not made to see why they were so fixed. In other words, it is not understood that practical considerations fix the absolute values, and therefore, the others are a mathematical result.

Still another reason is that some not knowing that the factors involved in a brake "lay out" are composed of arbitrary and derived values, mix them indiscriminately and give an arbitrary value to one that must have a derived value. For example, they think that the auxiliary reservoir volume can be arbitrarily fixed, when, as a matter of fact, this cannot be done.

I wish at this time to reserve any definite conclusions of the first problem where a braking ratio is arbitrarily chosen, and to touch upon the second problem of designing a brake when the braking ratio is not arbitrarily chosen in the near future, as in the second one either the length of the stop, or the rate of retardation in miles per hour per second is specified, and in this all of the factors of the first problem are necessarily present, and as the problem must be approached in an entirely different manner, and as brake shoe performance is one of the most prominent factors, this will be taken up separately.

What I have previously written in connection with this subject is necessarily quite lengthy, but not complete, at least as far as the reasons for some requirements are concerned. It is a long and obtuse subject, especially when everything involved is considered and when this subject is discussed, it is usually in parts, phases or sections, which as a rule, makes confusion worse confounded both in practice and when real problems are presented. Many of the readers may conclude that this has not simplified the matter by any means, but neither does a text book simplify any science but rather its purpose and usefulness consists in developing the science completely, which of necessity leaves simplicity as a quality of the subject, it being greater or less to the individual, according to his aptness and previous knowledge, but it must leave comprehension and understanding to the patience and diligence of the student, and its value to him will depend upon how completely he learns it and his ability to apply it in practice.

# Air Pump Strainer and Cover for Locomotives

By L. K. SILLCOX, Mechanical Engineer, Canadian Northern Railway

For the past two years the Canadian Northern Railway Co. has operated with complete success an entirely new design of air pump strainer, hung from the running-board, with intake opening 10 inches in diameter, face downwards. It has been found that after six months actual and continuous service the upper portion of the strainer is comparatively free from grit or dirt, the hair for a distance of 1½ inches having retained all foreign matter. It is a usual practice to wash pumps out every four months, at which time strainers are thoroughly overhauled, the hair being washed, dried and recombined. The device has been made standard for all equipments, consisting of two 9½-inch pumps or a single 8½-inch C cross compound unit, the pipe opening being 2½ inches, which develops into two 1½-inch pipes, one to each pump for the double equipment. Great care has been exercised in the detail design of the castings; for instance, the covers are flanged and fitted over rubber packing rings in order to eliminate any possibility of moisture reaching the working area of the strainer; again, the body of the strainer casting is extended down 2 inches, this to minimize the danger of condensation, snow or water, from being drawn up against the surface of the netting. Standard front end netting, 2½ by 2½ mesh, No. 9, B. W. G. wire, is used.

The device has been developed by a series of experiments conducted under the superintendence of Mr. S. J. Hungerford, superintendent of rolling stock, and Mr. William Clegg, general air brake inspector, and its general adoption is being rapidly proceeded with.

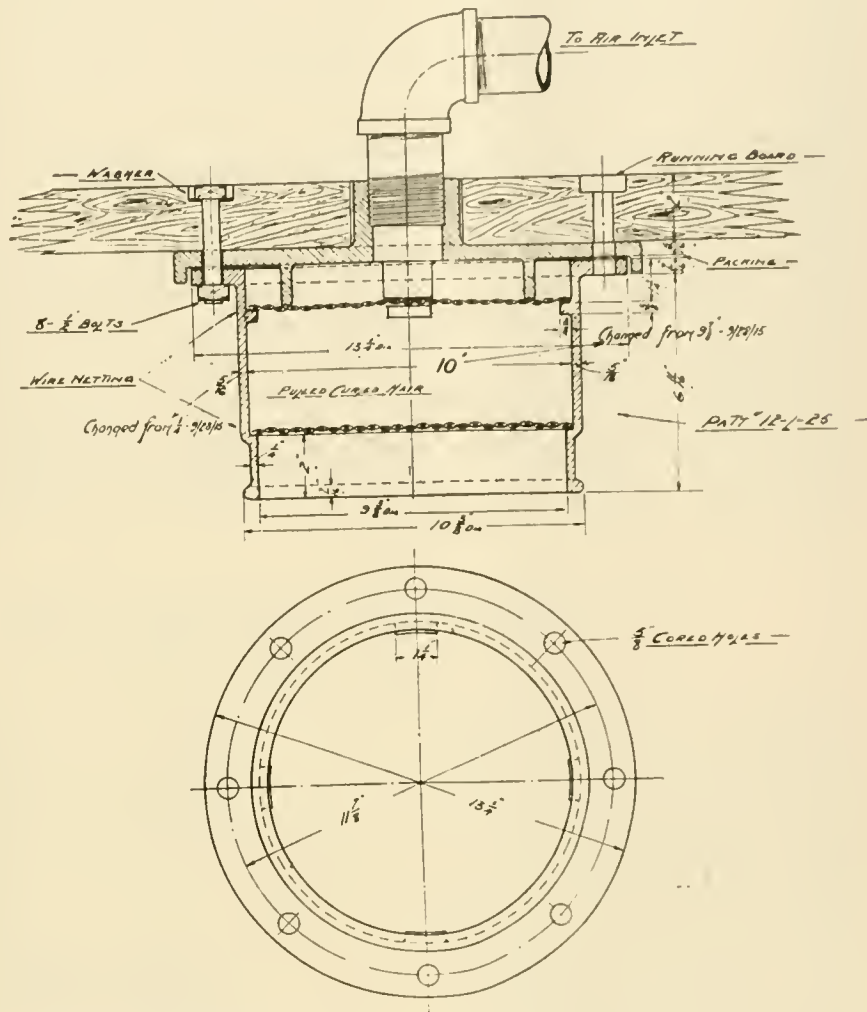

VIEW OF DETAILS OF AIR PUMP STRAINER AND COVER FOR LOCOMOTIVES.

## Industrial Locomotives

By J. CROW TAYLOR, Louisville, Ky.

It is always interesting to observe in the pages of RAILWAY AND LOCOMOTIVE ENGINEERING the thorough presentation that is made in all that is of interest in the development of the modern locomotive, and which continues to be such a distinctive feature in the pages of your popular journal. In your last issue the subject of Industrial locomotives was finely presented, and it occurs to me that a few added words would be in place at this time, as the class of locomotives referred to and the involved problem of their maintenance is a subject that has been brought into the limelight lately by some new rules of the Interstate Commerce Commission which were promulgated to go into effect January 1, 1916.

The new rules have to do with the inspection and testing of steam locomotives,

tenders, etc., and while the order primarily applies only to the interstate commerce it actually reaches out and includes some of the industrial locomotives, especially where they operate over parts of the tracks of lines doing interstate business.

Take, for example, a sawmill plant operating logging locomotives; if these locomotives are used for switching cars on to some railroad engaged in interstate commerce, which is a common thing among such mills, the railroad in question may ask that the industrial locomotives be inspected in accordance with the rules applying to interstate commerce.

There are a number of technical points involved here which have not yet been interpreted but the disposition of the

Interstate Commerce Commission is to hold that it should not work any hardship on a concern operating industrial locomotives to have them properly inspected and kept up to requirements, because it insures their maintenance in proper condition.

Maintaining industrial locomotives is a problem differing in many respects from the care and maintenance required for standard locomotives. This is owing to the fact that industrial locomotives operate over tracks that are rough and poorly ballasted, which subjects the locomotives to many wrenches and strains that do not fall to the lot of the standard locomotive operating on a properly kept railroad.

There is about the same difference between operating a locomotive on a well-

kept railway and one on an industrial line as there is between operating an automobile or motor truck on city streets and on poorly made country roads. The one calls for dependence under speed and smooth running, while the other calls for an order of ruggedness of structure that will stand up under rough treatment.

In the earlier days of industrial locomotive developments there was a fairly common practice of using for this purpose the second hand or discarded equipment of railway lines. Usually the old types of lighter engines that had been discarded by railroads for heavier and more modern locomotives were purchased for operating industrial lines. These were often considerably worn before being put to such service, and this together with the strains incident to service over the light rails and uneven road beds resulted in an enormous burden of machine shop repair work to keep the locomotive in order.

As the business and number of industrial locomotives grew in extent they de-

veloped special requirements and meantime discarded locomotives of railroad lines were often found too heavy for this service, consequently there was more turning to the purchase of the lighter types of locomotives built specifically for service on these industrial lines. The result of this was more satisfaction and service generally out of industrial locomotives, and gradually such locomotives have been improved with a view to standing this particular service so that the comparison of the industrial locomotive today with that of a quarter of a century ago shows wonderful progress and much more efficiency in their use. Still even with the progress made the industrial locomotive is quite a problem and its maintenance calls for lots of machine shop and repair work.

Every industrial plant operating locomotives over short lines to bring in raw material has to obtain a machine shop, and quite often something of a crew is kept busy at the work of overhauling and repairing locomotives. With the diffi-

culties experienced in keeping them in running shape in the service they have to perform and the rails over which they must run it is not to be wondered at that those owning and operating them are somewhat concerned about this matter of inspection and keeping them up to a certain standard. In the end, however, it will probably prove beneficial, even though it may seem expensive at first, and may even call for a better order of maintenance along the roads. There are very few industrial plants which are getting anything like the life and service out of the industrial locomotive that they should, and while they may kick and squirm under requirements to maintain them up to a certain standard the chances are that being forced to do this will in the end prove beneficial and more economical to the industries than the present method of simply trying to keep them in good enough shape so that they will run and pull their loads. The assurance is that this class of locomotive will receive more attention than they ever received before.

## Mechanically Operated Shop Whistle

By J. H. HAHN, Savannah, Ga.

In most railroad shops it is quite a hard matter to have the shop whistle blow promptly and correctly from the engine room. With the view of eliminating complaints from the Master Mechanic, the device shown in the accompanying illustration was devised. By using this device it is possible for the timekeeper to blow the whistle from his office.

The air is admitted to the cylinder by opening a cut-out cock in the supply line. The air is released from the cylinder by opening the cut-out cock B after the cock A has been closed. The cylinder, which is about 4" in diameter, is mounted on a post or suitable stand under the whistle and piped to the timekeeper's office or to any other part of the shop.

After assembling the levers, etc., measure the distance the rod C moves down when the whistle valve is open and regulate the piston in the cylinder to travel this distance by placing an oak block in the lower end of the cylinder. With a little practice any desired blast can be secured. And the device is easily made and very inexpensive.

### Drifting Valves.

By WILLIAM H. ROBERTS, CINCINNATI, O.

In order to help the engineer have a successful trip with the small allowance of oil which many of us seem to think is sufficient, I will try and make plain how this can be done to keep the oil from burning and hot gases from getting to cylinder and valves through exhaust, and air through cylinder cocks. Have four  $\frac{3}{4}$ -

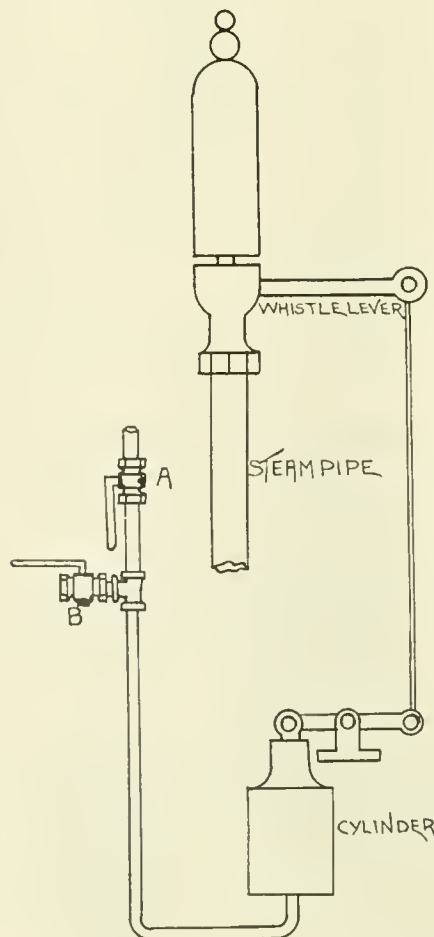

DETAILS OF MECHANICALLY OPERATED SHOP WHISTLE.

inch check valves made, tap in to cylinder cocks above top of valve, screw the check valve in cylinder cock so check will close when pressure is in cylinder, connecting these check valves up to a pipe leading to back of cylinder saddle, where it connects to the steam valve operated by a governor, the piston of which is connected with a pipe to center of steam chest. When throttle is open steam passes to top of piston, pushing it down, closing valve and shutting off steam so it does not go to check valves. When throttle is closed, steam valve on boiler head being open, steam raises valve in governor, passes to both ends of each cylinder, keeping cylinder cocks closed so no air can enter cylinder.

### Blows and More Blows.

By A. D. CARL, SALAMANCA, N. Y.

The subject of valve and cylinder blows, has, I think, been sadly neglected and the amount of money saved each year on the different railroads throughout the United States would greatly increase if we could locate the blow the first time we tried. It doesn't make any difference about finding out which particular ring is broken in a piston or valve, but if we can tell if it is a valve or cylinder blow and which side, we have accomplished what the roundhouse foreman most desires and that is a reliable report.

I did not touch all the blows that occur in an engine in my last article, neither did I make my meaning as clear as I would like to.

We have valve and cylinder blows, by-pass and balance strip blows, loose cylinder bushings and broken bridges and loose false valve seats. The part the good engineer plays is finished when he locates the blow. The shop force will do the rest when they get a dependable report.

Now let us take up the balance strip blow on a slide valve engine. This blow is not as loud as a cylinder packing blow and the reverse lever jerks when the engine is running. Place the engine on the right top quarter with the reverse lever in the front corner. Now set the brake and open the throttle and try to pull the lever to the center of the quadrant. If a balance strip is down on the right side our lever will move hard or we may not be able to move the valve at all, due to the extra steam pressure on top of the valve.

If the lever moves easily, we will try the other side in the same manner. If it is cylinder packing let us proceed in the same manner as though we were testing a piston valve engine. With the engine on the right top quarter and the reverse lever in the corner, we will set the brake and open the throttle, then let us pull the reverse lever to the center of the quadrant. If the blow stops, it may be due to a broken bridge in the back end of the valve seat or it may be the cylinder packing on that side. To make sure let us pull the lever to the back corner. If the blow starts again we will call it cylinder packing, if not we will blame the bridge.

Our slide valve engines have one position blows as well as piston valve engines. We must not lose sight of the fact that the steam can cross from one engine to another on a slide valve engine as well as on a piston valve engine, due to the back pressure caused by the restricted nozzle opening. We have the same exhaust clearance and the same lead opening to contend with that we have in a piston valve engine.

The only safe way is to do your testing with the reverse lever and you will never

have to tell the foreman you "guess" the blow is here or there but you can tell him it is here or there and be positive that he will find just what you have reported.

Recently we had a case of both admission and exhaust rings stuck in a valve. The engineer reported both valves blowing and as he explained it to me, there was no position in which you could place the engine or the reverse lever so as to stop the blow.

I proceeded to test in this manner: I placed the right engine on the top quarter, set the brake and opened the throttle slightly. The blow was as bad as though the cylinder packing was gone on that side and there was a large amount of steam escaping at the front cylinder cock. Then I pulled the reverse lever to the center of the quadrant but the blow continued as it also did with the reverse lever in the back corner. I also tried the cylinder cocks with the reverse lever in the center, and, while there was an escape of steam, from both ends of the cylinder, I did not think that the amount was great enough to cause such a blow at the stack.

I then placed the left engine on the top quarter, set the brake and opened the throttle. The blow continued, so I pulled the reverse lever to the center of the quadrant and it still continued. Then I lifted the cylinder cocks and found that right there the trouble was located—a bad blow at both cylinder cocks and at the stack. I had the valve pulled on that side and they found the four rings compressed and stuck. So the blow was found and cured.

Let us not jump at hasty conclusions where blows are concerned, for a bad report means time and time means money.

#### An Irish Old-Timer.

By CON RYAN, CORK, IRELAND.

It is always interesting to observe in the pages of RAILWAY AND LOCOMOTIVE ENGINEERING the occasional illustrations and descriptions of old time locomotives

that undoubtedly were of some service in their day. Among the others there is a clever writer recalling an occasional Erie Flyer, but the best of them are insignificant in comparison to some that are still running on our fine railroads in Ireland. I enclose a photograph of a specimen locomotive built in 1850, as shown on the builder's name plate. This engine still runs on the Cork, Blackrock and Tanage Railway. In its sixty-five years of service, of course, it has had occasional general repairs, but no organic changes to speak of. In the early days the natives of Blackrock could be seen walking five or ten miles to meet the train hauled by this locomotive so that they have a long run home. The Erie Flyers, so-called by Mr. Fallon, had a brief existence at the best. Ours are immortal, and improve with age. Their frames never break, their bolts and studs are properly fitted, their fireboxes wear out, but they never explode. Our railways are ways of pleasantness, and all our paths are peace. Our cars have compartments where a wedding or St. Patrick's Day party can be by themselves. Our firemen are flute players or fiddlers, and the mellow music of the jewsharp can be heard above the low murmur of the smooth running train. There is no idiotic haste, but we get there just the same. Others have their ways, and we have ours. Nobody was ever killed on this road and in all likelihood never will be. Both sides of the road have high fences, and no one ever thinks of climbing over them. If they did such a thing, they would be put where they would be well taken care of for a long time. As for running after dark they believe in the wise saying, when the night cometh no man can do any work.

#### Automobiles as Freight.

The railroads all over the land, realizing the importance of handling automobiles as freight, constructed special cars for their transportation. At present there are about 70,000 automobile cars in existence in the United States. But 70,000 has proved entirely inadequate. At this time shipments are badly complicated through the fact that over 150,000 freight cars are lying along the Atlantic seaboard and inland as far as Buffalo, Pittsburg, Chattanooga, Atlanta and Mobile, because of lack of ships to take their cargoes to foreign ports. Other little things like snow storms in the West and floods in the South have meant more cars unavailable and given traffic managers of automobile companies a serious problem to solve. Because of their inability to secure enough automobile freight cars The Willys-Overland Company, of Toledo, has hit upon the expedient of shipping a part of its output tarpaulined in flat cars and gondolas—in order that its huge daily output be kept moving as fast as manufactured.

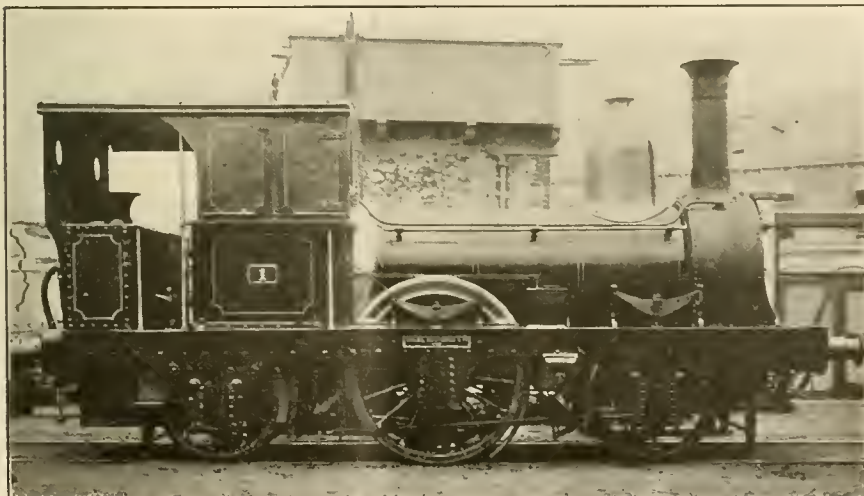

LOCOMOTIVE NO. 1. CORK, BLACKROCK AND TANAGE RAILWAY.

# Safety First Railroad Rail System

By WM. H. WOOD, M. E., Media, Del. Co., Pa.

The particulars for an improved safety railroad rail of balanced construction described in an article in RAILWAY AND

firmly. The rail can be easily taken apart after the bolts are removed and can be lifted vertically out of place.

Sixth: The fish and tie plates as made with ribs or lugs will prevent the spreading of the rail sections when spiked down on the ties.

Seventh: The section of the rail will allow the vibration to be partly released, reducing the crystallization to a minimum, this is what has reduced the life of the present rail to be dangerous.

Eighth: The rail will be spiked down to the tie in the same way as the present rail.

Ninth: The present rail used is too light, and the sectional shape is not of a balanced construction, and being secured directly to the ties, the crystallization will be more rapid, so that when the limit is reached the breakage will occur, and this will take place in extra cold weather when contraction will be at its greatest point.

It needs no further explanation in order that the reader should see that the plan of securing the rail by fish plates as now used will not only be made simpler by the safety first rail system proposed, for the rail will not only be made stronger, but the vibration producing crystallization (which is the direct cause of break-

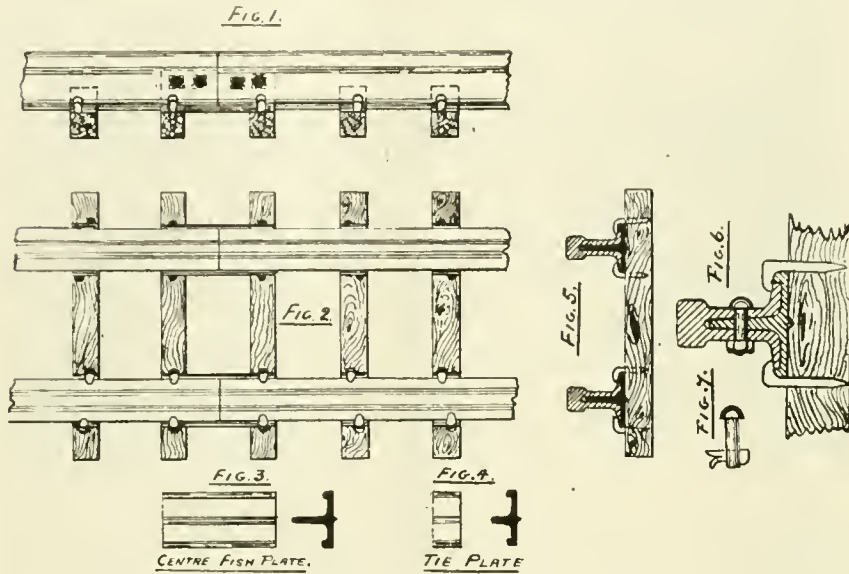

DETAILS OF WOOD'S SAFETY FIRST RAILROAD RAIL.

LOCOMOTIVE ENGINEERING, September issue, 1915, page 203. The accompanying drawings will explain more clearly than the drawing of the single section that was published, as will be seen from the following figures:

Fig. 1 shows a side elevation of the rail.

Fig. 2 shows the rails as used on the ties.

Fig. 3 shows the center fish plate.

Fig. 4 shows the tie plate.

Fig. 5 shows the sectional view of the rail on tie.

Fig. 6 shows an enlarged section of the rail and center fish plate, also shows it bolted as is usual.

Fig. 7 shows a bolt where the rail could be attached with a split cotter instead of being secured by nuts.

First: There is no difficulty in making or rolling this rail referred to, nor is there any difficulty in rolling the center fish plates and tie plates in length, thirty feet and having them sawed off to the length required for fish plates and tie plates.

Second: The rail can be used in connection with the present rail as the section vertically would be the same depth, no difficulty in their being used with present rails until systems are completed.

Third: The rail of this section made with not less than 135 or 145 pounds to the yard which is at this time required for the increased weight of the engines and cars being used.

Fourth: The fish plate is rolled, with ribs or lugs on each side, taking in the width of the rail, thus holding it more

Fifth: The tie plate can be made of the same section as fish plates, with central

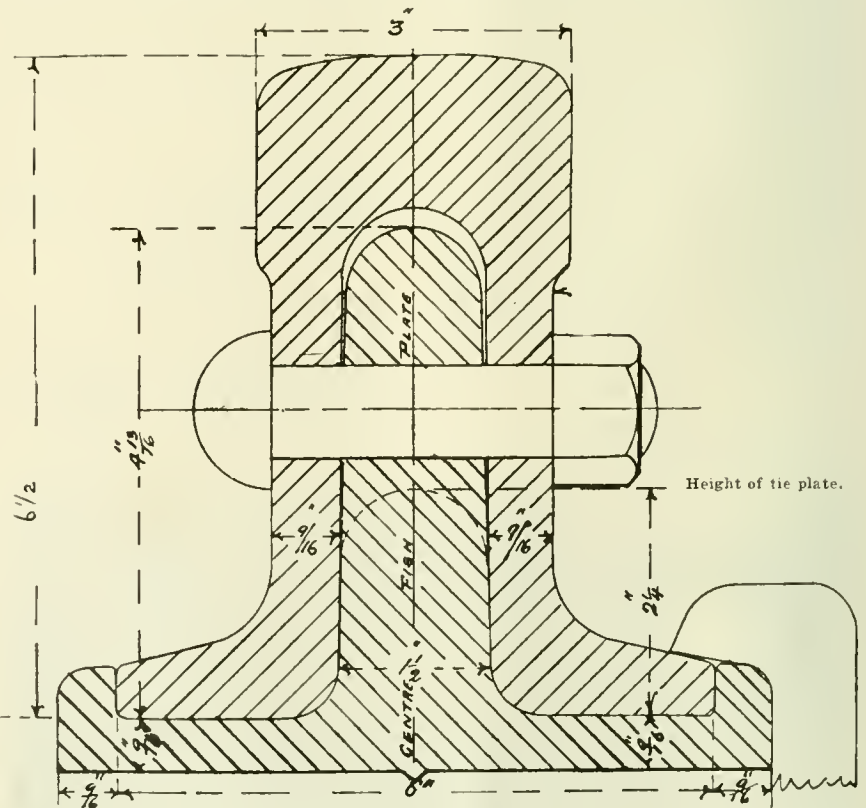

SAFETY FIRST RAILROAD RAIL.

ribs made less in depth and with the ribs or lugs on each side; these will take the place of flat plates which are now used.

age), will be reduced to its lowest per cent. by the balanced construction of a double-webbed rail.



# Advantages of the Brick Arch in Modern Locomotives

## Details of Its Construction, Application and Repairs

The advantages of the brick arch in the fireboxes of the modern high-powered locomotives are so well known and so universally admitted that it would almost seem idle at first glance to make more than a mere passing reference to the growth of its application as sufficient proof of its recognized efficiency and great and growing popularity. In this latter regard it may be briefly stated that among the 70,000 locomotives in service in the United States almost one-half are now equipped with brick arches, and its growth may be almost certainly foretold as becoming almost universal in the next twelve or fifteen years, the new and high-powered type of locomotives being nearly all equipped with the device, and the older

ern locomotive, should be occasionally referred to and information furnished up to the present hour, of which it may be thought a simple matter of applying the device and replacing the burnt-out portions of fire-brick from time to time, something more than a superficial knowledge of the structure and uses of the brick should be obtained by all interested in the mechanical appliances used on the locomotive.

It should be remembered that since its appearance on the Boston & Providence Railroad in 1857, where it was first introduced by Mr. George S. Griggs, it has undergone a variety of changes in form, and is still engaging the minds of some of the cleverest American engineers with a

under the barrel of the boiler as shown.

These openings admit of the pipes being placed in position. The holes are cut 1/32-inch larger than the outer diameter of the tubes, and the opening in the outer sheet readily admits of means for expanding the tube, and also for the purpose of beading the end of the tube, which is usually left a little longer than in the case of flues generally in the tube sheet, as there is no danger of the projection of the beaded portion burning, being in contact with the water. The opening in the outer sheet is fitted with a threaded brass plug which serves as an additional inspection plug and is readily removable and facilitates the cleaning of the boiler.

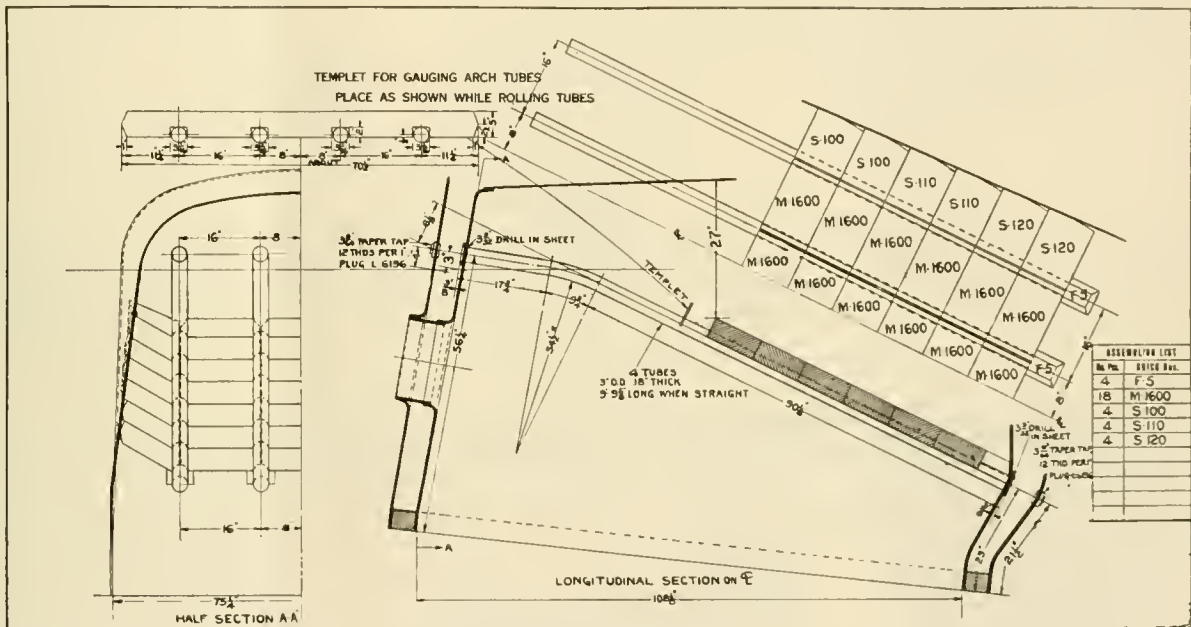

TYPICAL ARCH FOR ATLANTICS, PACIFICS AND MODERATE-SIZED MIKADOS.

and smaller types of engines being in many cases deemed hardly worth while equipping, as their capacity at best is limited, and their days are numbered, and it is a fact that in small fireboxes and at low steam pressures the advantage of the brick arch is not so marked as in the larger class of engines. Hence the increase in its application may be foreseen as being almost universal in the time to which we have referred.

Again to that large spirit of enquiry among the younger railroad men, as well as others not so young, there is a constant spirit of enquiry in regard to the forms and details of the device, so that it is well that this matter, as well as other important matters pertaining to the mod-

view to further improvements. Perhaps the most popular form in which it appears at the present time is that shown in the accompanying illustrations chiefly on the Mikado and other types of locomotives. It will be observed that there are several tubes that pass longitudinally through the firebox, the tubes being connected on one end to the back sheet of the firebox, and at the other end to the inner sheet under the flues. These pipes are usually 3 inches in diameter, and are generally known as No. 7, B.W.G. in thickness. In order to secure these pipes in place, openings are cut through both in the outer as well as the inner sheets of the boiler, one opening being in the back sheets over the firedoor, and the other in the throat sheets

It may be stated in passing that these tubes aid considerably in the circulation of the water in the boiler, and if kept clean the steaming qualities of the boiler is improved by the use of these tubes. Apart from the water circulation theory, however, the principal use of the tubes is to sustain, or partially sustain, the bricks which are placed crosswise on the tubes with their outer edges resting against the inner sheets of the firebox. In the earlier forms of the brick, arch pieces were formed of considerable size, but experience has shown that the smaller pieces are much more economical besides being more readily handled. Formerly it was usual to partially support the bricks by a series of bearings attached to the side

sheets of the firebox. These firebrick arch lugs, as they are termed, were placed so that each of the large kind of bricks formerly in use would rest on two of

the tube nearest to the side sheets. In some of the older and smaller fireboxes where lugs are still used the lugs are now of a circular form like a projecting stud

are found to be very durable, and if their removal is advisable a blow of a hammer will remove them forthwith, and in no case are indentations or recesses now

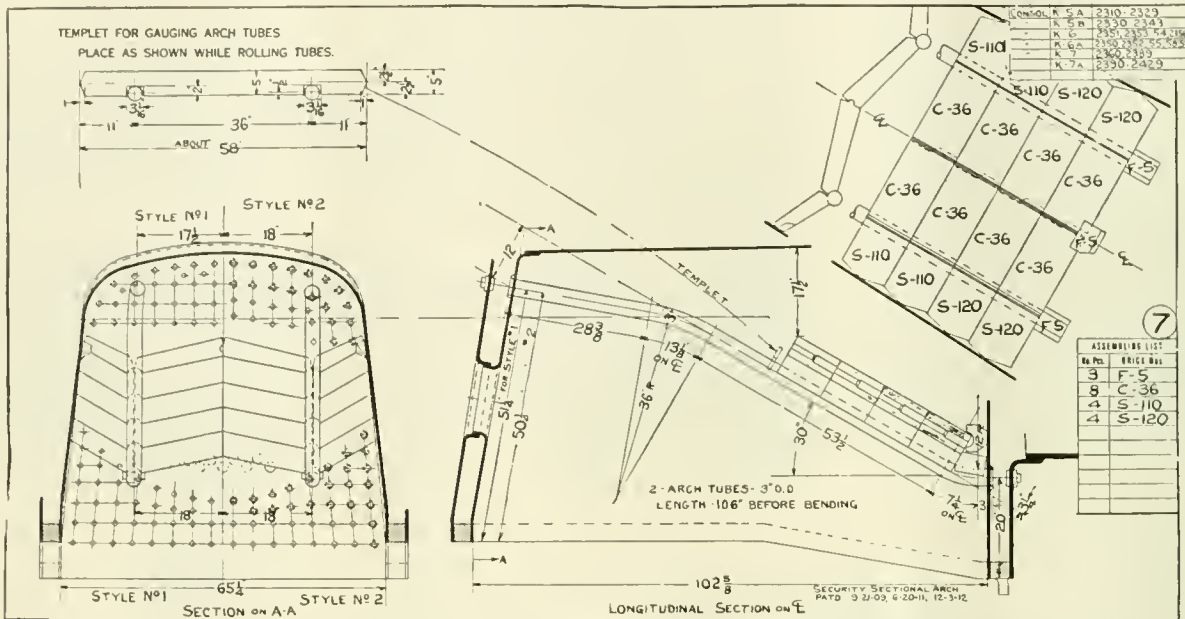

ARCH IN SHALLOW BOX CONSOLIDATION ENGINES.

them, and recesses were cut in the bricks to accommodate the lugs. In the newer forms this is no longer necessary as the arrangements now are such that the pieces

and a short piece of pipe forming a protective thimble is placed on the stud and forms a saving covering for the stud, and when the action of the flame has partially

made in the bricks to cover the supporting studs, as this was found to be a source of weakness in the bricks superinducing early fractures and rapid decay.

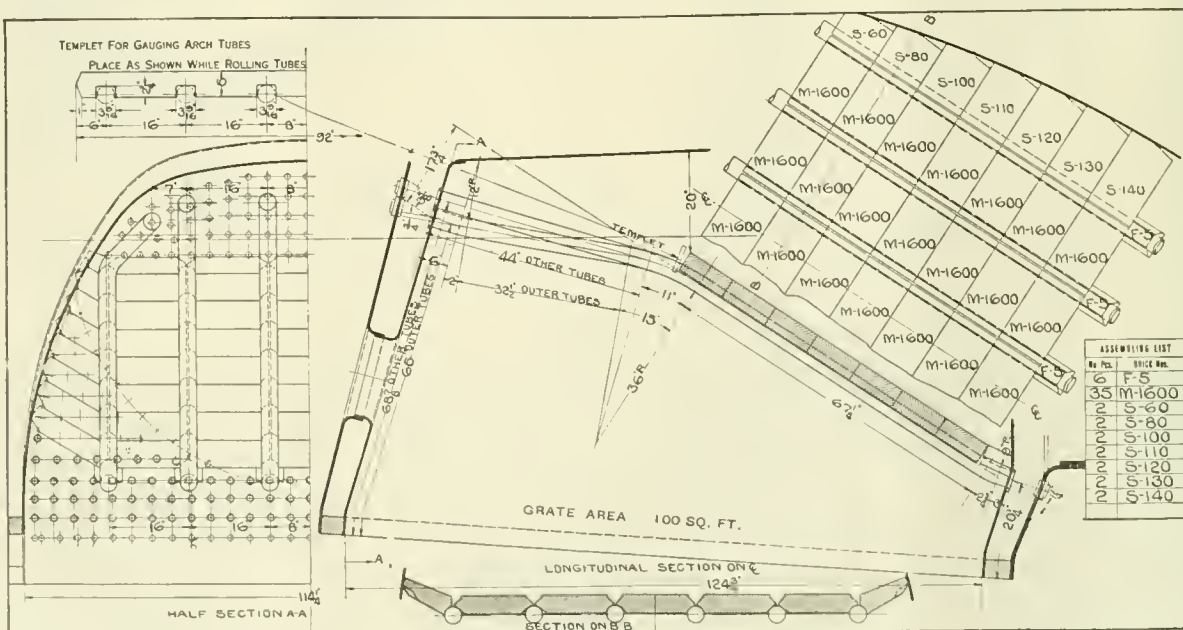

TYPICAL ARCH FOR LARGE MIKADOS, SANTA FE TYPES AND MALLET.

of brick running along the sides are so constructed that they rest against the side sheet at an angle, and a groove on the side forms a substantial bearing on

destroyed the thimble it can be readily replaced. In other cases a projecting stud is welded solidly to the side sheets in place of the threaded stud, and these

It was also formerly the practice to furnish the bricks nearest to the flue sheet with narrow projections extending to as much as 4 inches forming open spaces be-

tween the bottom of the flue sheet and the front end of the bricks. At present the practice is to insert short separate pieces of brick made for the purpose and adapted to the particular conformation of the throat sheet. These openings are of advantage not only in superinducing an extra draught which has the effect of retaining a constant degree of heat in that portion of the fire, but aids in consuming or preventing the excess of smoke, which is an important advantage in the use of the brick arch. Much ingenuity has been shown in the design of these openings or methods of holding the arch a certain distance away from the flue sheet, and they practically eliminate accumulation of coal and cinder on top of the arch, and the particles of unburned coal that may have reached that locality naturally fall over the arch into the fire, and are so consumed. In cases where the firing space under the arch is sufficiently large a spacer block may not be necessary, but generally a short spacer block may be used with good advantage. In a shallow firebox a longer spacer should be used. It may be noted here that the bricks nearest the sides have a slightly rounded bearing side against the side sheets to allow for contraction and expansion in the firebox and prevent the brick from any tendency to form a wedge and thereby cause the outside arch tubes to spring out of alignment, and on the event of this happening from any cause a device is now in use whereby the arch tube may be straightened while in place.

As we have already stated the arch tubes

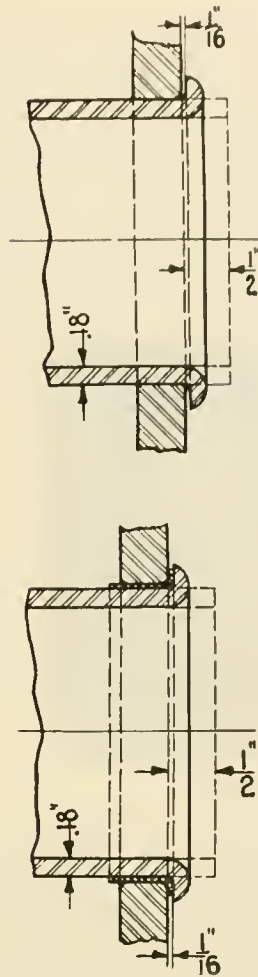

RECOMMENDED ARCH-TUBE SETTING.  
Without ferrule for new work; with ferrule for old holes reamed.

lowed out on the under side so that they are not only lighter, but have a larger heating surface so that their capacity or contact with the smoke and other unburned gases is greatly increased and the opportunity of combustion much improved. An extensive series of tests by the American Arch Company has demonstrated the value of this important improvement which is one of the marked features of their products.

Regarding the element of durability, the brick arch in regular service generally needs renewal, or partial renewal, once in 30 days, the average distance run by the locomotive between renewals being between 5,000 and 6,000 miles. Partial renewals may occur in the case of flue leakage, which, it may be stated, has a pernicious effect on the durability of the bricks, in a ratio to the amount of water that may be allowed to come in contact with the heated bricks. In the case of repairing of flues only a single section of the bricks need be removed, and these may be replaced with new bricks without disturbing the remaining portions. It may be readily imagined that the central sections of the brick arch are more subject to decay, as whatever variation there may be in the temperature of the flame it is usually more intense nearer the center of the fire. Hence the sides and lower portions of the brick arch do not require so frequent renewals as the central or more exposed portions. The cost of a complete renewal will average \$6 or \$8, while the designs being so finely adapted to the varying sizes of fireboxes,

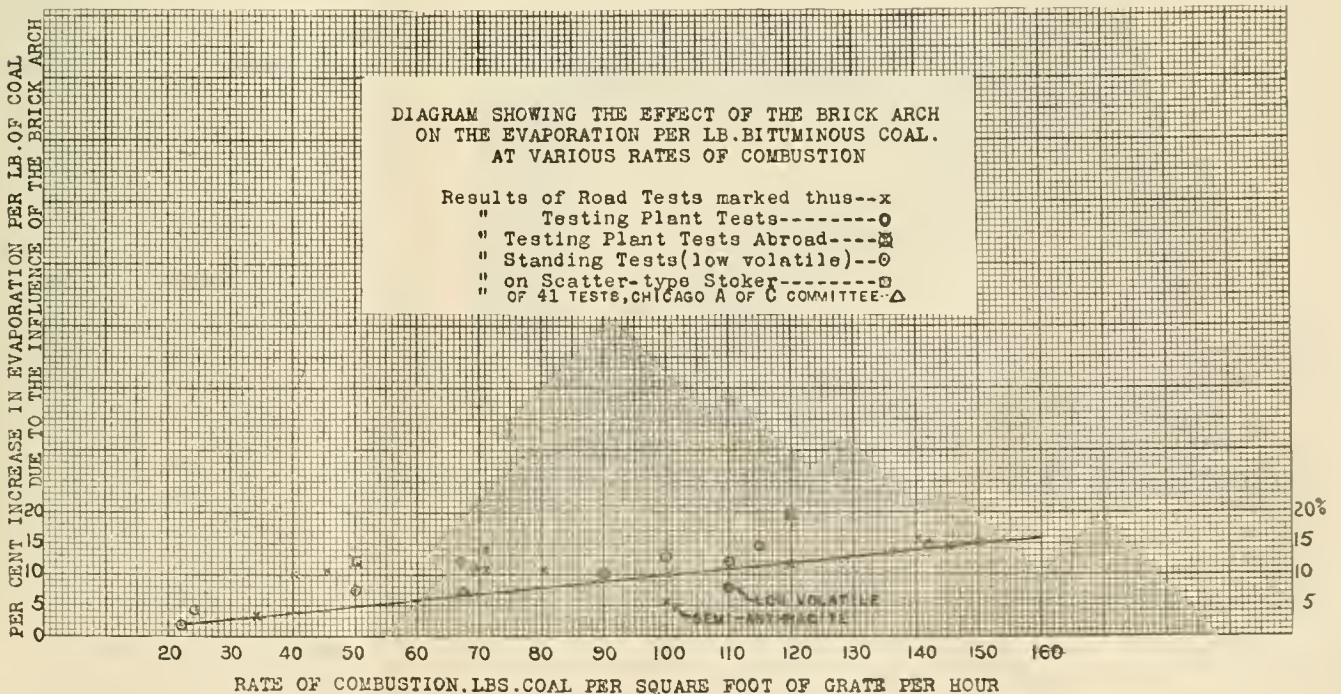

should be kept clean, and this should be attended to when the boiler is washed; mechanical cleaners having recently been constructed for this purpose, and if this is

done the arch tubes need not be renewed until the general renewing of the fire tubes occur. It will also be observed that the bricks as now constructed are hol-

little or no work is required in fitting the sections to their appointed places. In this regard the variety of designs are numerous and all of merit in their adapt-

ability to the forms and sizes of the fireboxes, the same form of firebrick not being, as may be imagined, equally adaptable to all.

Referring again to the water tubes it is good practice when first applied to expand and bead the flues steel to steel, but in old work it is recommended after holes may be slightly worn to ream the holes and apply copper ferrules. In all cases a larger amount of metal should be allowed to project—at least  $\frac{3}{8}$ -inch—to se-

contrast that in regard to the use of the superheater while it increases the efficiency of the steam generated and decreases the amount of steam consumed per horse power hour, it does not increase the boiler efficiency. The brick arch on the other hand increases the boiler capacity directly by adding to the evaporating surface by aiding combustion and by reducing the heat losses. This is accomplished by forming a sort of combustion chamber on what would otherwise be

boiler efficiency from this item alone.

Reports from many roads indicate a smoke reduction of 50 per cent. by the use of the arch, and in regard to flue repairs, reports from 35 roads show an average reduction of 45 per cent., and 37 others reported much less work from flue plugging. This being the case it shows that there is already a large reduction in roundhouse work by the use of the brick arch, while the marked improvement in designs, especially in the matter of using smaller sections of brick makes the application and repair of the device comparatively easy of accomplishment.

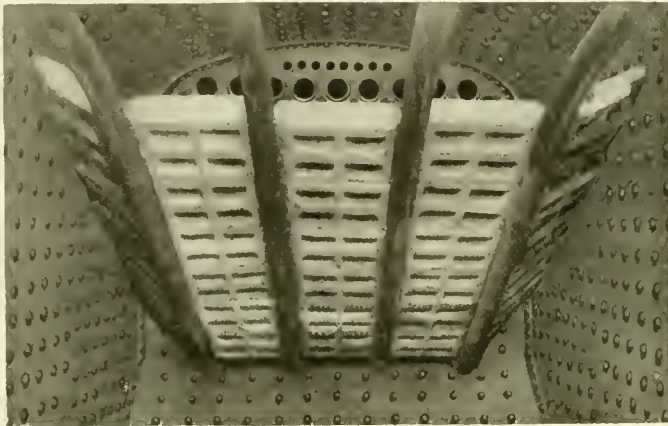

VIEW THROUGH FIREBOX DOOR.

cure the impossibility of any tendency to a possible withdrawing of the flue. In regard to this tendency to accident which is common to all mechanical devices subject to high pressures, it may be stated that there were 60,000 tubes of this kind in use in 1914, and 12 accidents were reported, 6 of which were due to improper application, 3 to negligence in cleaning,

a straight firebox. It has the quality of holding the particles of coal and coal dust until they can be burned, thereby increasing the efficiency of the evaporating surface. Its efficiency, as we already pointed out, increases as the rate of combustion, or as the amount of coal burned per square foot of grate per hour, increases. When burning 30 pounds of coal per hour

#### Progress and Principle.

Progress is based upon principle, not upon policy; it moves forward, never backwards, always towards the right and against the wrong. It does not necessarily mean peace, but will involve conflict only when that is imperative. It is the survival of the fittest, not so much in man's power over nature, but through the power of principle in his control of self and his influence over his fellows. Ignorance and selfishness will antagonize and may temporarily impede the triumph of this fundamental truth, but ultimately it must be recognized that true progress means a broad unity of all great interests and activities and that purely individual or selfish aggrandizement has no proper part in the plan of human progress.

A proper recognition of this, in identification with and in judging as to the merits of all great activities makes their real interest, as well as that of society at large, the same, simply because principle must ever be the underlying foundation of all real advancement, and therefore, no activity, individual or collective, can ever attain distinction in the world's progress unless in harmony with this law.

Progress means quicker movement. Great undertakings require great preparation and equipment, not only in ability, knowledge and experience, but in confidence and courage to promptly apply them. Large equipment and great opportunity bring increased responsibility. Where one life was touched a century ago, many thousands are affected. Machinery has become intensely powerful and influential, but individual effort and responsibility cannot wisely be hidden behind machinery. It has revolutionized the world's methods, but when it gets so all-powerful and ponderous as to blot out individuality and become an end instead of a means it will be an obstacle to instead of a promoter of real progress.

#### Grinding on Emery Wheels.

In grinding tools on an emery wheel, if possible let water drop on the point of the tool. Otherwise keep your finger near the point of the tool, and when the tool is getting warm plunge it into cold water.

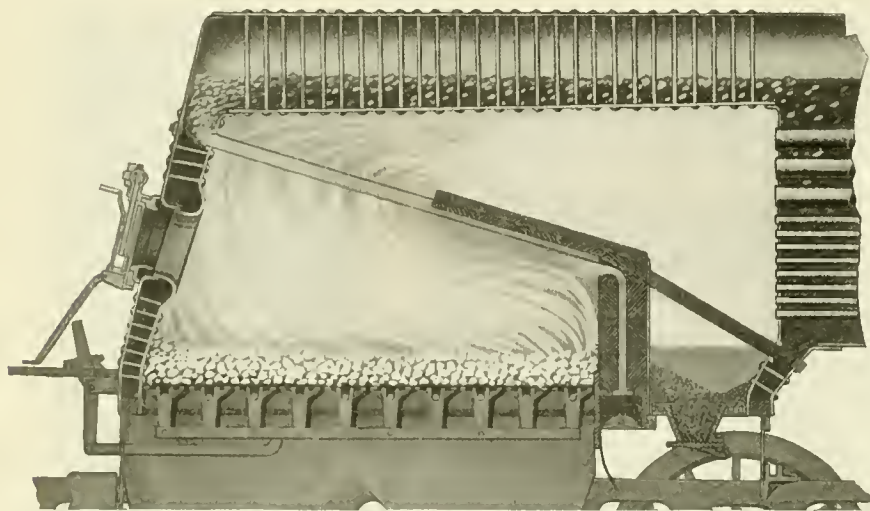

GAINES FURNACE AND COMBUSTION CHAMBER MAKES IDEAL ARRANGEMENT FOR LARGE LOCOMOTIVES IN LIEU OF BARREL COMBUSTION CHAMBER.

and 3 due to faulty material, so that if the application and cleaning had been properly attended to only 3 arch tube failures would have been reported in one year.

Coming to the question of efficiency as a saving device which in the last analysis is the acid test of all improvements on the locomotive, it may be said by way of

we may expect an increased efficiency of 3 per cent., and when burning 100 pounds of coal per square foot per grate per hour we may expect an increased degree of efficiency of 10 per cent. Tests indicate that at a rate of combustion of 100 pounds of coal, the brick arch will effect a reduction of 42 per cent. in loss by sparks. This is equal to a gain of 7 per cent. in

# Department of Questions and Answers

## Graphite.

F. M. S. Stillwater, Minn., writes: In the March issue you recommended graphite for making pipe joints and for lubricating moving parts. Would you kindly describe the physical and chemical nature which go to make graphite such an efficient lubricant for steam valves and cylinders? I would also like to know if graphite would not serve with greater efficiency on valves if it could be fed in alone without mixing it with valve oil?

A. The qualities that go to make up graphite, so efficient as a lubricant, is the fact that it is a solid and cannot be squeezed from a bearing, even by enormous pressure. It is the most slippery and unctuous solid known, and forms a uniformly smooth coating over frictional surfaces. It is durable and cannot be burned or frozen, and is not affected by moisture or acids. It is one of the forms of carbon, just as coal or diamonds are, and while it is found in varying degrees of purity much depends on the methods of cleaning it from other mineral impurities. In this regard the Joseph Dixon Crucible Company has attained a degree of efficiency that is not surpassed. On account of the difficulty in distributing dry flake graphite it is commonly used in connection with oil or grease. Dixon's Flake graphite added to either oil or grease increases its lubricating value and produces as near a perfect lubricant as science has discovered or practice demonstrated. A heat that disintegrates an oil or grease and a cold that freezes either have no effect whatever on Dixon's graphite. As we already stated that the graphite alone is difficult to distribute, hence the combination of oil and graphite or grease and graphite provides the best service, each supplying the qualities lacking in the other.

With regard to the amount of oil experience will soon prove to anyone the proper mixture. From a high railroad authority we have a report from a railroad in the Middle West, that where four pints of oil were used on the cross-compound locomotives in a run of 238 miles, when mixed with graphite two pints have been sufficient. So it may be taken that there is a saving of 50 per cent. in oil. The glaze of graphite is really a thin veneer that is marvellously smooth and durable. It is almost frictionless, and has the quality of filling up the small interstices that exist on the most highly polished surfaces of all metals. This seems to be impossible to oil or grease alone. Not only so, but with the advent of superheated steam its lubricating quality is not in the least diminished.

It will thus be readily observed that with an admixture of oil or grease the graphite reaches every part of the contacting surfaces and remains there, and while there are different varieties and grades of graphite on the market, it should be used advisedly because some grades used will do more harm than good. In all cases where graphite is used instructions can readily be secured from the supplying firm. These instructions are based on extensive experiments and may be confidently relied upon.

We might add further that in other moving parts of the locomotives and cars the use of graphite as a lubricant greatly enhances the diminution of friction. Its lubricating qualities are unquestioned. In some parts of the air brake appliances it may be used in the dry state to advantage. In the case of large bearing surfaces it is, however, more satisfactory to be used in the manner and with the mixtures to which we have referred.

## Defective Brake Valve.

A. H. H., Baltimore, Md., writes: What can be wrong with the Westinghouse G-6 brake valve when the valve handle is placed in service position and but a very slight amount of air escapes at the brake valve exhaust port and the equalizing piston does not lift. There was no obstruction in the preliminary exhaust port or in the groove in the rotary valve and the opening through the preliminary exhaust port bushing was  $5/64$  of an inch? A.—The equalizing discharge valve may not have lifted due to leakage from the main reservoir into the equalizing reservoir or from the brake pipe into the reservoir through the brake valve body gasket or past the equalizing piston ring, but if the proper amount of air to correspond with a  $5/64$  opening does not escape from the brake valve exhaust port, it indicates that the groove in the face of the rotary valve does not fully open the preliminary exhaust port to the atmosphere. This may be due to a twisted rotary valve key or be aggravated by lost motion between the rotary key and the valve handle or it is possible for the positions on the valve body to be imperfect but when the rotary key is perfect the cause of the preliminary exhaust port failing to open fully may be somewhat difficult to ascertain as we can recall an instance in which the exhaust port of the G-6 brake valve did not open fully and an investigation disclosed the fact that the rotary valve was manufactured by an outside firm and the groove in the valve seat was fully  $1/16$  of an inch too short and the end of the groove barely opened the exhaust port to the atmosphere. After lengthening the

groove to correspond with that in the Westinghouse rotary valve no further trouble was experienced.

## Defect of Universal Valve.

A. M., Harrisburg, Pa., writes: What is wrong with the universal valve of the U. C. brake equipment when there is a blow of air from the release slide valve exhaust port when pressure is first admitted to the brake pipe and which then stops after an emergency application is made or if the finger is held tightly over the exhaust port for a few seconds? A.—It is generally due to a dirty and sticky condition of the release piston and slide valve. While the blow at the exhaust port exists the release slide valve is partly off its seat which may have been the result of bleeding the brake by means of the emergency reservoir drain cock which is a wrong practice, as in this way the brake is applied while the emergency reservoir pressure is exhausted and the brake cylinder pressure under the slide valve tends to unseat it and deposit foreign substance on the slide valve seat. Again the brake may have been applied while the pressure leaked out of the brake system thus leaving the release piston and slide valve in application position and through friction and foreign substance the spring at the application end of the piston may have been of insufficient tension to overcome the resistance and return the release piston to release position, then when air pressure is admitted to the system and the blow starts from the exhaust port from the slide valve being partially unseated, holding the finger over the exhaust port temporarily prevents the escape of emergency reservoir pressure and in a few seconds' time sufficient pressure is accumulated in the release slide valve chamber to force the release piston structure to release position and the movement usually seats the slide valve provided that no foreign substance has remained on the seat or slide valve face. The manner in which holding the finger over the exhaust port results in the movement of the slide valve and pistons is that when the equalizing piston and slide valve are moved to their release position from pressure entering the brake pipe, the release end of the release piston is opened to the atmosphere through the equalizing slide valve and graduating valve while the port leading to the application end of the release piston is blanked so that as soon as sufficient pressure is accumulated in the release slide valve bushing to overcome the resistance of the release piston structure, the pressure moves the valve to release position.

# Railway Locomotive Engineering

A Practical Journal of Motive Power, Rolling Stock and Appliances.

Published Monthly by

## ANGUS SINCLAIR CO.

114 Liberty St., New York.

Telephone, 746 Rector.

Cable Address, "Locong," N. Y.  
Glasgow, "Locoauto."

### Business Department:

ANGUS SINCLAIR, D. E., Pres. and Treas.  
JAMES KENNEDY, Vice-Pres.  
HARRY A. KENNEY, Secy. and Gen. Mgr.

### Editorial Department:

ANGUS SINCLAIR, D. E., Editor.  
JAMES KENNEDY, Managing Editor.  
GEO. W. KIEHM, Associate Editor.

### London Representative:

THE LOCOMOTIVE PUBLISHING CO., Ltd.,  
3 Amen Corner, Paternoster Row, London, E. C.

### Glasgow Representative:

A. F. SINCLAIR, 15 Manor Road, Bellahouston,  
Glasgow.

### SUBSCRIPTION PRICE

\$2.00 per year, \$1.00 for six months, postage paid in the United States, Canada and Mexico. For other parts of the world, \$2.50, or ten shillings. Single copies, 20 cents. Remit by Express Money Order, Draft, Post Office Order or Registered Letter.

Mailing address can be changed as often as necessary—always give old and new address, and if you subscribe in a club, state the name of the agent.

Please give prompt notice when your paper fails to reach you regularly.

Entered at the Post Office, New York, as Second-class Mail Matter.

### The Clamor for Shorter Hours.

It is the policy on the part of some of the trade journals, including some of the more pretentious of the engineering press, to take sides against the loud call for shorter hours of labor made by some of the brotherhoods of railway employees. They might as well try to stop the waves of the sea. And while we cannot expect all that is demanded at this time by the joint associations, we may as well frankly state that they do not expect to get all they ask for themselves. Experience has taught them that unless they ask for a good deal they will get nothing. The law of supply and demand has much of the commercial spirit of the Hebrew children in it. They ask a great deal for an article, expecting that the buyer will offer perhaps less than half. On this hypothesis they act wisely because the less they

ask the less they will get. The Brotherhoods learned this lesson long ago, and when they have made up their minds to ask for something more for their labor they may as well ask for a good deal, because they know that they will never get it—at least not all they ask for.

In the present instance, however, it is not really an increase of wages in the gross amount that is asked for, but a reasonable reduction of the hours of labor. Of course, the railroads see it in a different light, like two men looking at a distant landscape through different ends of a telescope. Shorter hours must needs increase expenses in the hiring of more men. Overtime must increase expenses in an increasing ratio. Many railroads are on the brink of ruin now. They are between the upper and nether millstones. The question is not therefore a question of compassion on the workers. It is a question of existence on the part of the railroads. Where is the money to come from? This question is not so easily answered. While there has been a slight increase in rates allowed by the Federal Commission here and there, it does not at all meet the situation, and the inevitable increase is not being met at all.

It might be thought at first glance that the increase everywhere in the volume of transportation would provide vast resources. So it does. But the appliances must be increased, and the terminal facilities must be expanded. This is mandatory. The under dog must wait. And so between these political and physical forces which seem immutable the situation deepens and darkens into a growing menace, and a problem has arisen baffling in its solution, and calling forth the exercise of the wisest statesmanship, if there be such a thing amongst us. The people, from whom all authority comes in a Republic, are blinded by party prejudice, and trammelled by a weight of tradition that is deplorable. Demagogues mislead the multitude. Commodities were going to be cheaper when the present government came into power. Any one might know that this is a matter beyond governmental control. The variable prices in commodities have always inevitably had a higher tendency, and the next government, whatever it is, will see them still higher. Hence the clamor will continue.

Above and beyond all this, however, there is something reasonable about a working day of eight hours. It is no new experiment. How serenely it operates in New Zealand, and other far-off ends of the earth, but the politicians have not time to look at it. All they seem to think about is themselves, and, of course, their allies, the office-holders. We do not know of any of them working more than eight hours a day, but we know a great many who work less, and are better paid than railway men for less work. Hence,

all governments are, more or less, class government, that is operating favorably towards its own component parts. The evil is that we cannot all be government officials. Some of us must carry on the world's work, and there is no class of men who are doing their part more thoroughly or more earnestly than the railway men.

We are not pointing towards government ownership in railroads. That would be a colossal disaster, at least in America. What we need is wiser legislation, more thoughtful consideration of the needs of the transportation companies in the regulation of rates, so that the natural and inevitable call of labor and facilities for labor could be met in a spirit of liberality and justice. This seems at present far off, but its coming is inevitable when the people send the right kind of men to legislate for them.

Coming back to the present clamor for an eight-hour day for the railroad men, while we have neither the desire nor space to take up all its details, we cannot shut our ears to that voiceless multitude of railroad workers who have no one to plead their cause. We refer more particularly to that skilled class of mechanics engaged in construction and repair work. No one seems to give them a thought. Yet they are the very heart of the great machine—the valve gear as it were, and like the valve gear they are largely hidden and are only visible to the enquiring eye. And yet their reward is small. Their hours are long. Their skill is unquestioned. Their backs are bent with the incessant yoke of poorly requited toil. Their noses are at the grindstone, so to speak, from starry morn till starry eve, and nobody gives them a thought. Diogenes said that they whose wants are few are nearest to God. The wants of railroad shop men must be few or they could not live, and perhaps there is a recompense in self-denial that is not visible to the common eye.

We cannot close these observations on the present threatening aspect of affairs without some reference to the Railway Mail Pay question. It is shameful that a liberal government should impose its terms upon transportation companies in a way that private enterprises are not permitted to do. The hiring of a car and the payment of such space as the hirer may find necessary is exactly similar to the renting of a house and then lowering payment because the tenant had no use for certain rooms last month. Or perhaps, the upper floor may be deserted in the winter time, or some of the family may be away to the sunny South in the winter, or the cool North in the summer. Is it to be supposed that any landlord would accept such conditions? Of course not.

In the words of a protest just presented to the Committee on Post Offices and

Post Roads against the so-called Moon bill, which would impose on the railroads the space scheme of pay for transportation of mail matter:

"It would almost seem that the authors of this law felt that its provisions were so unreasonable, so unjust and so un-American that the railroads could only be induced to submit to them by actual force in the way of a fine so heavy that they could not afford to test their rights.

"The anomaly and injustice of the present law is that it provides pay for such travelling postoffices only when occupying full cars of the length of forty feet or more. The railroads are compelled to furnish the department with about four thousand three hundred apartment car postoffices less than forty feet long which are not paid for at all."

#### Pulverized Fuel for Locomotives.

The restless spirit of a desire for economy in fuel consumption in steam locomotives continues to engage the attention of many of the cleverest engineers of our time. This is encouraging because it is in the right direction, but through it all there is a dark vision of the future when the coal will be all burned. Our engineers should not wear this dark mantle of prophecy. It does not become them. All the schemes that can ever be devised by human ingenuity will not greatly add to the period when the last coal fire will be quenched. They may rest assured if that day ever comes, something else will be at hand. As long as the sun shines there will be all the heat we need. This talk of the future does not ring true. We have high assurances of heat and cold and spring time and harvest, and the world has never yet been forsaken in these essentials, and never will be.

Economy, however, is wealth, and if more heat can be got out of coal than we are getting at present it would be a good thing for all concerned. At a recent meeting of the New York Railroad Club the subject of pulverized fuel in locomotives was discussed by some of the ablest railroad men of our time, and it is evident that some real progress is being made in the direction of a better use of coal. We observed that little or no attention was given to the subject of pulverizing the coal although we all know that it costs something to erect a pulverizing plant, and convey the mineral in its rough state as well as in its pulverized state from place to place. Again the cost of the appliances used in blowing or inducing the mineral dust into the furnaces has its relative cost, all adding to the general expense, which in the last analysis cannot be ignored.

We had the fullest opportunities some years ago to observe extensive experiments on the Manhattan Elevated railroad, where an ordinary locomotive was

transformed into a powdered coal burner, and a new locomotive constructed with all the ingenuity and experience available at that time, to give the scheme a fair trial. The failure in both cases was complete. The variations in nozzles, and baffle plates, and air ducts were endless, but the locomotive could do little more than pull itself. Like the man who took all day to catch a horse in the open field, and then it was not much use after he had caught it, it took a long time to get up steam, and then the steam refused to stay up at even a moderate pressure. The rapid clogging of the flues at the fire box end was something bewildering.

As is well known there is no such thing as pure coal. In the earth's convulsions when the great forests were overwhelmed and the mountains fell upon them much fragmentary material was mixed among the crashing timber, and as the aeons of ages rolled on the solid mass became crystallized into what is called coal, and if our inventors whose abilities are great, and our experimenters whose opportunities seem boundless, could devise some means of separating the wheat from the chaff then our pulverized fuel burners would glow with an incandescent flame that would make the fires of today look as "moonshine unto sunshine, or as water unto wine." If aluminum can be taken out of clay by the action of electricity, coal should be taken out of culm, but any one who attempts to burn the scrap heaps of the coal mines of Pennsylvania in their present state has his day's work cut out for him.

We are glad, however, to see that the spirit of enterprise grows with the growing years, and we will be surprised if there is not an early, even if only a partial, solution of the problem of conserving some of the enormous waste that is at present made in the use of coal, and the use of coal in a pulverized state seems to be coming into the realm of accomplishment.

#### Exactness in Doing Work.

We recently listened to a body of railway men discussing seriously the question, Which has done most for the world, inventive ability or manipulative skill. Inventive ability was considered of much greater value than skill of achievement, yet we cannot help feeling that work skillfully performed has done as much to promote the world's industries as the faculties which plan enterprises or invent new devices. The difference between the inventor and the expert workman is that the former is liable to ramble from one industry to another, while the latter adheres to recognized lines of work and increases their value. One of the prominent weaknesses of American industrial life is that too many workers are willing to try operations that they have not learned. Those who have not acquired skill or accurate

knowledge of any art or occupation, are a mob of weakness instead of a properly trained army of industry. They may have acquired a mass of general information, which may be a good thing in its way, but it resembles water running in a stream that might be made to drive power wheels or turbines, if the proper appliances were put in its way and its movement was properly regulated. General information is of little value unless when applied to a specific purpose. When a person learns to do any useful work well, he is likely to secure employment doing it; then he may have the means of applying general information to expand processes connected with his work.

A first class worker at any occupation, no matter how humble it may be, commends himself for advancement. The good mechanic, the efficient car repairer, the skillful fireman, the first class engineer, the quick accurate telegraph operator, the pushing, clear headed trackman, the flagman who protects his train and the machinist who does his work in first class shape are the men who will be chosen as railroad officials in due course. Education is a powerful lever to help men to ascend the ladder of life, but education is useless unless its possessor can apply it to a specific purpose and pushes with all his might the work he is engaged doing.

America is becoming so rich that a multitude of young men are gazing out of luxuriant homes for some easy occupation that may be turned into a business that will keep them from sheer idleness. It is amazing the number of robust youths who are looking for soft jobs. Nearly all first class railroad companies now operate employment bureaus to keep records of men seeking for work and it is a melancholy fact that by far the majority of the applications are for positions as clerks and for other light occupations. During last year a prominent railroad running out of Chicago received 511 applications for the position of clerk and telegraph operator, there were 107 applicants for the position of fireman and 137 men wanted work as brakeman or baggage man. The genteel jobs are those most sought after, the applicants not being aware that for a few years of ease they would lead themselves into a life of penury.

#### Science and Engineering.

"Where shall we draw the line between pure and applied science? For myself, I have been unable to find aught but a hazy line of demarcation." When the velocity of the propagation of light-waves was determined by scientific reasoning and experimentation of the most refined nature, the process of solving the problem remained for a long time in the domain of the exact sciences as a masterpiece of the human mind. 'But who dreamed to what utilitarian purposes these

light-waves would be made subservient? The genius of a Michelson carried them into the workshop, thence to the International Bureau of Weights and Measures at Sèvres, and gave us a value for the international meter in terms of light-waves that will remain absolutely unalterable as long as this old world moves in the luminiferous ether of the universe.' 'getting nearer the utilitarian service of the scientific study of light-waves, Dr. Anderson, of Johns Hopkins, has utilized them in making screws of hitherto unheard-of accuracy.' And when in railway shops nuts made by some firms would not screw on bolts made by others, the problem at first baffled the ability of the most prominent manufacturers of tools of precision in the country, but it was solved through the co-operation of a professor of astronomy.

"And this utilitarian use of science in making possible the construction of accurate screws has again reacted, as it were, and enabled the scientific mechanic to produce a little optical device that rivals, if it does not surpass, the telescope—the diffraction-grating. 'On the plane surface of its polished plate, made accurate to one-tenth of a light-wave, or within one forty-five thousandths of an inch, are ruled more than 45,000 lines, between which there is no greater error than one two-millionths of an inch. With this delicate piece of apparatus, made possible first by rigorous scientific research; secondly, by the skill of the artisan; thirdly, by a knowledge of and vigorous care to avoid temperature changes; and fourthly, by the accuracy of the mechanism which includes the accurate screw mentioned above, the astrophysicist has been able to tell us the composition, temperature, and distance of the stars. It is also possible for the physicist, the chemist, to tell us the purity of the material he is called to investigate; indeed, it makes itself subservient to many phases of engineering in the domain of metallurgy. And the end is not yet. Where can we draw a sharp line of demarcation between pure science and its relation to any and every form of engineering?'"

#### Hardening Steel.

Said a man in my hearing, "I have hardened steel for thirty years, and know how to test steel, and how hot it should be for hardening, and I tell you, in relation to steel springing and getting out of shape in hardening, it depends on how it is dipped in the water. I can harden dies and cutters and have them come out as true as when they left the tool maker."

It is an unquestionable fact, that the manner of dipping has much to do with this matter, but our friend should remember that his action is governed by natural law, as much as are the actions of

others; that steel springs out of shape in the fire from uneven heating, owing to an unequal or unnatural tension of some parts produced in forging; that difference in section at different points in a piece will cause more sudden cooling and contracting in some parts than in others; that some steel at the hardening heat will, in dipping, change in volume more than others; that with different steels all the different heats may be required for hardening, ranging from a yellow heat by daylight to a dark red by twilight; and finally after considering all the tendencies towards distortion and change of volume, resulting from a variation in any way from the best treatment possible, or a variation of quality or condition of steel from the best, there still remains this fact, that the steel by heating is expanded, and by sudden cooling for hardening, is very much contracted from its volume while heated. As the outer portions cool first sufficiently to become hard and unyielding, while the interior of the piece is still hot and largely expanded, there must be a change in shape or volume, or both, produced by hardening.

Was a piece of steel of any considerable size ever hardened, remaining exactly the same size and shape as before? Who believes the steel manufacturer, when he says his steel will do it? Or the skilled steel worker who says, "I can do it every time"? No, my friend, you are mistaken all around; your work doesn't come out true, but only nearer than by some worse methods. And it is not all in the way you dip it. If what you say were strictly true there would be "millions in it."

#### Study of Natural Laws.

People pursuing mechanical occupations are every year having their minds more and more drawn into the system of things which we call Nature which is too vast and various to be studied first-hand by any single mind. As knowledge extends there is always a tendency to subdivide the field of investigation, its various parts being taken up by different individuals, and thus receiving a greater amount of attention than could possibly be bestowed on them if each investigator aimed at the mastery of the whole.

One large department of Nature which is of the greatest importance to practical men is that of physics, or natural physiology. This term is large enough to cover the study of Nature generally, but it is usually restricted to a department which perhaps lies closer to our perception than any other. It deals with the phenomena and laws of light and heat; with the phenomena and laws of magnetism and electricity; with those of sound; with the pressures and motions of liquids and gases, whether in a state of translation or immolation. The science of mechanics is a portion of

natural philosophy, though at present so large as to need the exclusive attention of him who would cultivate it profoundly. Astronomy is the application of physics to the motions of the heavenly bodies, the vastness of the field causing it, however, to be regarded as a department in itself. In chemistry physical agents play important parts. By heat and light we cause bodies to combine, and by heat and light we decompose them. Electricity tears asunder the locked atoms of compounds, through their power of separating carbon dioxide into its constituents; the solar beams build up the whole vegetable world, and by it the animal, while the touch of the self-same beams causes hydrogen and chlorine to unite with sudden explosion and form by their combination a powerful acid. Thus physics and chemistry intermingle, physical agents being employed by the chemist as a means to an end; while in physics proper the laws and phenomena of the agents themselves, both qualitative and quantitative, are the primary objects of attention.

#### Combines Strength and Stupidity.

How it does delight some lathemen to come down on the wrench of a tail-stock. There is not a particle of use in it for ordinary size lathes; for a man who understands things will run year after year on ordinary work, and never tighten but one of the bolts, and the tail-stock will never slip. Another man will take the same lathe, and if it isn't well ballasted he is liable to pull the thing right over as he strains himself on the tail-stock wrench.

Unnecessary screwing of certain bolts is a fair test of a mechanic's intelligence. I once made the drawings for a planer to plane 5 or 6 feet square and 25 or 30 feet long. As a tool-holding arrangement, I put in the usual two clamps with four good size screws. The man who ran the planer broke a bolt every week. We made new ones of every kind of iron and every kind of steel, but still they broke. A planer right alongside of this one, doing exactly the same kind of work, using the same tools, taking the same cuts on the same pieces, but run by another man, never broke a tool bolt, notwithstanding there were only two of the bolts, and they were much smaller.

The foreman decided to change the planer operators. After the men were changed, the bolts began to break on the old planer and none broke on the new one. The trouble was that the man who broke the bolts had too much strength and no judgment. He never knew when to stop fooling with the wrench.

That man represents a class. These are men who break tool-post wrenches on lathes. They break any kind of open-ended wrench you can give them. A monkey-wrench volatilizes in their hands; they



strip bolts and nuts or spring face plates and angle plates and planer tables and burst pipe fittings and come down on the caps of journal boxes. If anything with a screw to it can be damaged they will damage it. If it is so strong they cannot damage it themselves, they will screw it up so unusually tight that somebody will have to damage it to unscrew. Such a combination of strength and stupidity has no natural place in a machine shop.

#### Natural Fitness.

The work of railroad building and operating has been done by men who acquired the necessary skill and knowledge by performing the operations they were afterwards required to direct. These men have been entirely efficient and their efficiency has been particularly conspicuous as heads of mechanical departments. One of the oldest and most numerous of this class is composed of men who, with an apprenticeship training and common school education as a foundation, have acquired by personal diligence the scientific knowledge that entitles them to rank as mechanical engineers fitted to perform satisfactorily the duties of superintendents of motive power and machinery. Those who aspire to reach the highest positions in railroad service must go through an ordeal of patient private industry, similar to that followed by those who become heads of the mechanical department. The habits and characteristics which enable a young mechanic to acquire broad knowledge by burning the midnight oil, are likely to promote his usefulness and advance his efficiency as a railroad official.

Ambition combined with industry are valuable forces for pushing a man upwards, but there is another characteristic which is extremely potential as a means of helping a railroad man towards the highest position. It is that subtle personal quality known as executive ability. Some people think that various forms of training will inspire an individual with executive ability; but our observation of results contradict this. Our experience is that executive ability is a natural product, like a genius for music, likely to be very sparsely strengthened by cultivation. The lessons of experience seem to prove that the hard knocks of practical work are likely to prove the best fertilizer for executive ability.

#### A Place for Every Tool.

Keep your tools handy and in good order. This applies everywhere and in every place, from the smallest shop to the greatest mechanical establishment in the world. Every tool should have its exact place and should always be kept there when not in use.

Having a chest or other receptacle with a lot of tools thrown into it promiscuously

is the very worst way of keeping tools. Some mechanics are so deficient in the sense of order that their tools are either left where they were used or thrown together in confusion. When a man of this type wants a wrench, chisel or hammer the search for it sometimes takes longer than it takes to do the job in which it will be used.

The habit of throwing every tool down when it has been used is one of the most detestable habits a mechanic can possibly fall into. It points to the slouch. It is only a matter of habit to correct that failing. Make an inflexible rule of your shop life to "have a place for everything and everything in its place." Shop foremen should see that this valuable rule is lived up to.

#### Perpetual Motion.

One of the first gleamings of mechanical intelligence was that some device could be invented that would produce perpetual motion without waste of energy.

There was coming before the investigating world the mystic stone of chemic force, which nobody understood; there were heat and light, electricity and magnetism, all competent to produce mechanical motions. Here then were the mines from which hazy ambition sought to seek its gem of gain without loss.

To people imbued with imperfect knowledge, the question is still rational, Why should perpetual motion be impossible? The answer came with increase of knowledge given by scientific investigation which proved that there is a very important principle known as the conservation of energy. This principle demonstrates that no power can make its appearance in Nature without an equivalent expenditure of some other power; that natural agents are so related to each other as to be mutually convertible, but that no new agency is created. Light runs into heat; heat into electricity; electricity into magnetism; magnetism into mechanical force, and mechanical force again into light and heat. The Proteus changes, but he is ever the same; and his changes in Nature are the expression, not of spontaneity, but of physical necessity. A perpetual motion, then, is deemed impossible because it demands the creation of force, whereas the principle of conservation is, no creation but infinite conversion.

#### Pipe Manufacturing.

The growth of railway clubs in the present century has been of incalculable benefit to railway men, not only in the interchange of opinions in regard to the improvements in means and methods possible of application to the science of transportation, but also as an important opportunity for instruction in the manufacture of railroad appliances which opens up a

vast educational field hitherto more or less concealed from the ordinary observer. An excellent illustration of this latter phase of the subject was the presentation of an illustrated lecture before the Western Railway Club, recently, on the subject of "Pipe Manufacturing." While the purifying of iron ore into steel is generally known as simply blowing air through the molten mass of metal whereby the oxygen in the atmosphere combining with the impurities in the iron pass off and leaves the steel in its refined state, it also does not require much information to see by what means the purified mass may be changed into billets and slabs, but the changing of a flat slab into a welded smoothly finished pipe at the rate of three-and-a-half miles an hour seems incredible, and yet this is being accomplished every hour of the day, and the speed increasing so that one hundred miles a day seems within hailing distance.

There are two methods of making standard pipe—the butt weld and lap weld process. In the butt process the slab of metal, a "skelp" as it is called, is made slightly wider than the circumference of the pipe and heated to a welding heat and then passed through a "bell" which turns the skelp into the circular form, bringing the two sides together very sharply and forming a weld. In the lap weld process the skelp is rolled with beveled edges so that in welding the pipe a lap is formed, forming a much stronger weld than butt welding. This makes an additional operation necessary, in which the skelp is first bent in the approximate shape of a tube with edges overlapping and then placed in a welding furnace and drawn out between two rolls over a ball—the rolls taking the function of the hammer and the ball the anvil as in a hand welding process. After cutting and threading the pipe is put under a hydrostatic test of from 600 to 2,000 pounds per square inch, depending on the size of the pipe and the use to which it is to be put. Apart from the perfection of the finished product, the amazing feature, however, is the rapidity of the operations, rivalling the printing press, and is one of the mechanical triumphs of our time.

#### Free Transportation for Track-Scale Test Cars.

The United States Bureau of Standards has completed an arrangement with the American Railway Association for the free transportation of its test cars between certain master scales in various parts of the country. The bureau has reserved the privilege of making other tests that it may desire, provided regular tariff rates are paid for transportation of the car outside of the route specified. The regular rates need not be paid if the bureau can secure more favorable rates from any particular road that may be interested in having its scales tested.

# Air Brake Department

## Special Instructions to Yard Shifting Crews Approved Methods of Repairing Triple Valves

### Instructions to Yard Shifting Crews.

In previous articles on the subject of brake valve manipulation and brake operation in passenger service, it was pointed out that in order to handle long modern trains with mixed brake equipments and make smooth stops with the air brake, a certain understanding of air brake conditions was absolutely essential, and it was also stated that it would be an advantage to contemplate yard shifting conditions, for the reason that if a train can be successfully handled and smooth stops made at low rates of speed, it should also be a possibility when making stops from higher rates of speed in road service. This, however, brings into consideration a condition that is not met with in road service; that is, attempting smooth air brake stops with unequal air pressures, and the one subject is broad enough to be considered separately.

It is generally understood that a smooth air brake stop is produced by a uniformity of retarding effect on the different cars in the train; and it is with a view of obtaining this that the following suggestions to yard crews in passenger train shifting service have been formulated.

In order to overcome rough handling of trains, engineers have been instructed concerning the amount of brake pipe reduction that is to be made during a stop, and you will be expected to assist them in this performance by complying with the following suggestions:

Let the engineer make the brake pipe reduction.

He has been asked to place a limit upon the amount drawn from the brake pipe on the initial, or first, reduction of the brake application.

He cannot do this if you assist in making the stop with the rider hose or the conductor's valve.

He can not be expected to control the amount of reduction when there is heavy leakage in the brake pipe or hose coupling, as such leaks continue the reduction beyond that intended by the brake valve operation.

Be governed by standard instructions, do not open a conductor's valve except in actual cases of emergency, then make a complete report of the conditions which necessitated it.

If you are making a stop with the back-up hose, expect no assistance from the engineer. His instructions are to leave the brake valve handle in running position.

If he is making the stop with the automatic brake valve, should you start a re-

duction with the back-up hose or the conductor's valve those two separate reductions will meet in some point in the train and cause a perfect triple valve to work in quick action or emergency, because the rate of brake pipe reduction exceeds the capacity of the service port of the triple valve to expand auxiliary reservoir pressure into the brake cylinder.

Under such a condition a defective triple valve may not work in quick action but one that has just passed a test on the shop rack will very likely do so.

It is rank presumption to assume that you can use a back-up hose and make a more accurate brake pipe reduction than can be made with the H-6 brake valve.

The accuracy of this same brake pipe reduction governs the kind of stop that will be made, rough or smooth.

Do not use the conductor's valve to assist in releasing brakes. If necessary the engineer can make as large an opening in the brake pipe with the brake valve as you can with the conductor's valve.

Rough handling of trains is caused by a difference in speed between certain cars in the train.

The difference in speed is made possible due to drawbar and coupling slack.

This difference in speed or rough handling during a brake application is due to a change of speed between cars being caused by a greater retarding or braking effect on some cars than on others.

This may be caused by a variety of conditions but the chief one that we are concerned with is the difference in retarding effect caused by unequal brake cylinder pressure, or too high a brake cylinder pressure consistent with the speed at which the cars are moving.

The difference in brake cylinder pressure on the various cars may be caused by unequal auxiliary reservoir pressures or by too heavy a brake pipe reduction, as any reduction from the brake pipe is effective on the triple valve nearest it first.

The same is true regardless of where the opening is made, only that the effect is more violent when the back-up hose is used instead of service position of the brake valve.

As an example of slack conditions and shocks when back-up hose are used, you will notice that when the train is stretched there is always a run in from the engine that resembles a collision because the brakes on the rear cars are heavily applied before those near the engine apply at all.

Conversely if the engine is using steam

and has the slack all bunched or the train solid when the brake application is correctly made with the back-up hose, the stop is almost as perfect as can be made with the brake valve.

The unequal auxiliary reservoir pressure may be obtained through coupling up uncharged cars with others that are fully charged, or by bleeding reservoirs through a mistaken idea of releasing stuck brakes, or through a more frequent practice of bleeding all the air out of the brake pipe before an engine and several cars are coupled.

It requires nearly three minutes' time to charge an auxiliary reservoir from "0" to 110 pounds with full pressure in the brake pipe, and under yard shifting conditions it may require five or six minutes or even more on a long draft of cars.

Therefore if you have bled the reservoirs or brake pipe on a certain number of cars in the draft, you would not expect the brake to apply on such cars if a stop was necessary within three or four minutes of the time the cars are coupled up.

If cars with the reservoirs bled, or with the brake pipe pressure exhausted, are coupled up to an engine and several charged cars you would expect the brake to apply on the charged cars and the failure to apply on the uncharged cars would result in a run in, or run out, of slack with severe shock and probable damage to equipment.

If riding on the uncharged cars at such a time you may conclude that the independent brake has been used on the locomotive and make a report of the rough stop in this manner.

By thus bleeding the brake pipe and reservoirs, not only rough handling results, but delays in testing brakes occur if train connections happen to be close.

On the other hand if the air pressure in the reservoirs is maintained the equipment is always ready for the brake test as soon as the air hose are coupled and angle cocks opened.

It costs money to compress air and every cubic inch wasted means just so much additional wear and tear on the compressor and requires just so much time to replace the waste, and on a hurried movement invariably results in a delay.

If the air pressure is maintained on the cars, all brakes will apply and release promptly under any yard movement condition that may be encountered.

In order to work to your own advantage as well as to that of the company

use the compressed air as though you were paying for it by the cubic foot.

Open no reservoir bleed cock except for the purpose of cutting out a defective brake. Make the engineer release the brakes.

Open no angle cock except for the purpose of admitting compressed air to the brake pipe of that particular car.

Do not exhaust air pressure from the brake pipe with the back-up hose unless actually necessary, and this is unnecessary after the train has stopped.

Whenever and wherever possible the train or draft should be stopped by making the brake pipe reduction with the automatic brake valve, and the back-up hose used as an emergency device.

Refuse to open the conductor's valve when the car is standing still and consume at least ten seconds' time in bringing the angle cock handle on a charged car from its open to its closed position.

Failure to economize in compressed air consumption is responsible for at least 75% of the air brake delays and to about 100% of the rough handling with the air brake.

To make this clearer, a rough stop is caused by too heavy a brake application in some part of the train, meaning a waste of air at some point.

Even if the rough stop should be made with the independent brake valve alone it indicates that the brake has been too heavily applied; therefore too much compressed air has been wasted through the locomotive brake cylinders. Even if the brake has been applied by the use of the back-up hose, compressed air is wasted whether the stop happens to be rough or smooth, as the capacity of the feed valve must be exceeded by a waste of air before the brake on the entire train can apply.

As to 75% of the air brake delays, practically all of the damage done to the foundation brake gear and operating valves is caused by unnecessary quick action or emergency applications, each an uncalled for waste of compressed air.

Make the conservation of air pressure your hobby, to illustrate that this is not merely imaginary, under modern operating conditions, a ten-car train of "LN," "PC" and "UC" equipment averages over ten cubic feet of compressed air capacity or ten of such cars one hundred cubic feet and that 110 pounds pressure requires  $8\frac{1}{2}$  atmospheres or 850 cubic feet of free air to charge the cars from zero to 110 pounds. With the minimum allowance for reduction in pressure due to change in temperature and leakage, the eleven-inch air pump, compressing about 40 cubic feet of free air per minute, will have at least twenty-five or twenty-seven minutes' work in charging such a train, or in other words the volume of compressed air stored on ten of such cars is equal to that stored on 50 passenger cars

having "PM" or high-speed brake equipment.

A  $\frac{5}{32}$  of an inch circular opening will expand air pressure under 110 pounds' pressure at a faster rate than an 11-inch air pump can compress it, or in other words the pump cannot hold the pressure at 110 pounds against a  $\frac{5}{32}$  opening, and from the size of the supplementary and emergency reservoirs under these cars you will readily see that it is possible to waste more compressed air from these reservoirs in 10 seconds' time than the pump can restore in 10 minutes' time.

You should understand that train slack cannot be changed gently and quickly at the same time and it cannot change roughly and slowly at the same time, therefore it is apparent that there is a considerable time element involved in smooth air brake operation, so that if your methods of giving signals require a stop in a short distance it must be made by a heavy application and as a general proposition a rough stop is the result, and conversely if ample distance is allowed in which to make the stop it can be done with a light application, which tends to allow the train slack to gently adjust itself and produce a smooth stop.

#### Repairing Triple Valves.

If we were standing still instead of advancing in the air brake art, the above would be a threadbare subject, but as the number of valves in a train in freight service is constantly increasing, and the difficulties encountered in operating these valves in passenger service are constantly multiplying, the repairing of triple valves is a subject as much alive as it ever was, possibly of more real importance than ever before. The repairing of triple valves in railroad repair shops is a practice that was instituted shortly after the triple valve was invented and this has generally been continued in the majority of railroad repair shops. In recent years several railroads have, however, come to the conclusion that this is an expensive practice and have discontinued repair work on triple valves and are sending them to the manufacturers instead, and in the long run, we believe that this is the correct practice to be employed.

Some years ago the repairman who could repair and pass the largest number of triple valves over a test rack, was considered to be the most valuable man to employ on this line of work, at the present time, however, air brake men are beginning to consider the man who rightfully recommends the largest shipment to the manufacturers for repairs and there is an excellent reason for this because the triple valve that passes the rack test is not always suitable for service, that is, the rack is not necessarily faulty, but a triple valve entirely unfit for service can by certain methods, be made to pass the

test on the standard rack as required.

The most difficult operations in repairing triple valves are fitting a packing ring and facing off the slide valve and seat, and a repairman's principal education should consist of knowing when this should and should not be done. When the wear of the slide valve as well as that of the seat passes a certain point, it should be returned to the manufacturers, and the same thing applies to the fitting of the packing ring, only that the latter is of more real importance than the observation in connection with the slide valve and seat.

We question whether a packing ring should ever be fitted in a railroad repair shop; however, there are permissible arguments, both for and against the practice, the principal one against it is that there are no facilities in railroad shops for properly doing the work, and an argument in favor of thus fitting the rings is that in the railroad shop it is generally done with less wear on the outside circumference of the ring than when it is done in a grinding machine, hence some air brake men figure that if this work can be done with, say several thousand less applications or rubs through the piston bushing, the ring will give several thousand more applications in service before being worn out, and whether this is right or wrong will not enter the subject at this time, as an effort will be made to point out the observations that should be made when inspecting a triple valve before any attempt is made to make any repairs whatever to the valve. We have many times gone over the points of wear that should be observed and stated the permissible amount of enlargement of the piston bushing, but it is now desired to entirely omit such references to slide valve wear and how the seats can be trued up, and confine the remainder of this article to but one point of fit which is the most important observation to be made in connection with triple valve cleaning and repair work, and which, as a general proposition, is given the least attention of any part of the triple valve. This is the fit of the triple valve piston in the bushing.

The writer has had occasion to investigate cases of stuck brakes and slid flat wheels and during the time the condition of the triple valves on such cars were, of course, closely observed, and some valves were found to pass the test rack and go into service and from 4 to 6 weeks afterward the valve would be removed on account of a stuck brake, a slid wheel or some other disorder and when placed on the test rack the valve would fail to pass the test, but after being cleaned and lubricated the valve would pass all of the tests and again be placed in service and when examined a month later the valve would again fail to pass the rack test until after it was cleaned, while on the

other hand some triple valves were placed in service and were never heard of again until the brake on the car was due for cleaning and when removed the valves passed every test before being cleaned or in any way repaired. At the same time it was noticed that some of the valves that passed the test were new ones and had the packing rings stuck solid in the piston groove, yet they passed the test with the stuck ring when from all previous laws governing air brake defects these valves should have failed to pass the ring leakage test.

Now there are evidently good and sufficient reasons why certain triple valves apparently in good condition will not give more than from four to six weeks service without manifesting packing ring leakage and other valves, even if the packing rings are stuck, will never manifest any disorder and, again, when certain valves have been cleaned or repaired, either by railroad shops or the manufacturers and are exposed for a short time to a low temperature, they fail to pass all of the packing ring, application and release tests and others similarly exposed pass every test without any difficulty, and the same lot of valves after being in a warm room for a short time all valves pass all of the tests required. We understand that specifications do not call for a triple valve to be tested at a time that the temperature of the metal is below the freezing point, but in many parts of the country the temperature of the valve in service is below the freezing point for about six months of the year, therefore a triple valve should be repaired and maintained with a view of successfully meeting the adverse conditions encountered. Another point that we have assumed the reader to understand is that all stuck brakes and slid flat wheels are not due to the triple valve operation, they may be caused by incorrect manipulation of the brake valve or by deficiencies elsewhere, but in passenger service a stuck brake or flat wheels on one car alone in the train calls for a pretty close examination of the triple valve of the car in question.

In an effort to make a long story short, there is a reason why a slow rate of rise in brake pipe pressure at the rear of a long train releases all brakes but one or two or why in cold weather, all except one or two are released or why one triple valve with a stuck packing ring will give no trouble between dates of cleaning and one with a perfectly fitted ring will be in the test room about every four weeks, and as a general proposition the only difference between them is that the valve manifesting the chronic case of sticking or packing ring leakage, has a main piston, the outside diameter of which is considerably smaller than the bore of the piston bushing or, in other words, the piston is not a fit in the bushing.

The results obtained from a fit of a

piston can be observed by placing an old style G-6 brake valve on lap position and opening the angle cock at the rear of the tender, then, by placing an H-6 brake valve in the same position and opening the angle cock, the difference in the rate of drop in equalizing reservoir pressure will indicate results obtained by a neatly fitted equalizing piston, or in fitting up the steam portion of a governor, no repairman with any experience will attempt to fit a packing ring in the governor cylinder unless the governor piston is a fit in the bushing and the bushing or cylinder is true or no air pump repairman will fit up an air pump until a fit of the air piston in the air cylinder is obtained, and the amazing part of it is that in the triple valve where the fit is even of more actual importance, scarcely any attention whatever is paid to it.

As a remedy for some of the undesired action obtained from triple valves we would recommend first, a fit of the triple valve piston regardless as to how it is secured and even if it is necessary to send the valve to the manufacturer for this purpose, and this will be considered expensive, but flat wheels and stuck brakes are also expensive and if the money is spent on the triple valve the result will be a more efficient brake at least. To do this will, however, break up any practices of scraping, reaming or rolling a bushing, therefore if the triple valve piston does not fit within 1/64 of an inch there should be no attempt made to pass the valve over the rack.

The acid test for a triple valve is that it be so fitted that every test specified by the code can be made without the use of any lubricant, thereafter it may be found that lubricant is actually unnecessary for the triple valve and this also applies to universal valves, control valves and distributing valves, however, the question of suitable lubricant will be touched upon in a future issue.

#### Air Brake Convention.

The Twenty-third Annual Convention of the Air Brake Association will be held in Atlanta, Ga., beginning Tuesday morning, May 2, 1916, in the Convention Hall of the Hotel Ansley.

As this will be the first Air Brake Association convention held in the South for several years, it will doubtless attract many air brake men who might not be inclined to attend were the convention held elsewhere. An additional attraction will be the meeting of the Southern Railroad Club which has been arranged to convene coincidentally with the meeting of the Air Brake Association.

During the session, papers on the following subjects will be read and discussed:

Slack action in long passenger trains, its relation to triple valves of different

types, and consequent results in the handling of passenger trains.

Proper piping of locomotives and cars, specifications and requirements for pipe in air brake work.

Adequate hand brakes in heavy passenger equipment cars.

Best methods of educating apprentices to give the railroad companies efficient air brake mechanics.

Care of modern passenger brake equipment. Factors contributing to the minimum cost of maintenance with the maximum efficiency.

Accumulation of moisture and its elimination from train and yard testing plants.

Need of efficient cleaning and repairing of freight car brakes. Recommended practice.

In view of the many recent improvements in air brakes for both passenger and freight cars and the continued increase in the length of both passenger and freight trains, the above subjects are the most timely and carefully selected that have ever been prepared for an air brake convention. These subjects will undoubtedly attract one of the largest attendances of any meeting ever held, because no other list of subjects has ever offered the possibilities that may be derived from a discussion of the papers on handling passenger trains and the care of passenger and freight equipment. It should be possible for the air brake specialists to get together and definitely decide upon certain suggestions that would tend toward a betterment of air brake conditions in general and establish a uniformity in practice in brake repair work.

In addition to these subjects, Mr. W. V. Turner will deliver an air brake lecture on the afternoon of May 4.

#### Removal.

Mr. F. M. Nellis, Secretary of the Air Brake Association, announces the removal of his office from 53 State St., Boston, Mass., to 165 Broadway, New York City.

#### Civil Service Examinations.

The United States Civil Service Commission announces an open competitive examination for junior signal engineer on April 19, 1916. From the register of eligibles resulting vacancies will be filled to positions in the Interstate Commerce Commission under the act providing for the valuation of the property of common carriers. Grade I are paid from \$1,200 to \$1,800 a year. Grade II, from \$720 to \$1,080 a year. Theory and Practice of railway signaling counts 50 points. Education, training and experience, 50 points. Applicants should immediately apply for Form 2039, stating the title of the examination for which the form is desired, to the United Civil Service Commission, Washington, D. C.

# Biographical Sketch of Walter Victor Turner

Assistant Manager of the Westinghouse Air Brake Company

In a recent issue of the *Electric Journal*, Mr. S. W. Dudley has an excellent article giving a biographical sketch of our esteemed contributor, Mr. Walter V. Turner, assistant manager of the Westinghouse Air Brake Company, from which it appears that Mr. Turner is English by birth and education but went to New Mexico at an early age, and became secretary and manager of the Lake Ranch Cattle Company there. There he developed that fine physical and mental alertness which has characterized his later activities. Becoming part owner of a sheep and cattle ranch the bright prospects of his partnership were wiped out by the tariff legislation of the first Cleveland administration, and Mr. Turner took to railroading and entered the service of the Santa Fe in 1897. In a few weeks his energy, determination and resourcefulness had gained him the position of foreman of car repairs at the Raton Shops. Some years before, while still on the ranch, he had picked up a discarded triple valve from the debris of a railroad wreck. This device had already aroused his interest in and purpose with regard to means for controlling trains and their possible service to civilization and humanity, which has continuously increased in vigor and earnestness from that day to this. The air brake became his particular hobby. It offered a field peculiarly attractive to his ingenuity and analytical faculties, and he soon became known as a more than ordinary student of the theory as well as the practical application of the principles of air brake construction and operation. His first invention, made about this time, was a handy tool for removing the packing ring and cleaning the packing ring groove of the air hose coupling.

When the Santa Fe Railroad was ready to put its air brake instruction car into commission in 1900, Mr. Turner, although only three years off the ranch, was recognized as the best qualified man on the railroad to put in charge, and his experience while on this car and later in special duties for the mechanical officials of the road, gave him an insight into practical conditions and requirements, and an understanding of the vagaries and influence of human factors and motives which were later to prove of great advantage in the working out of larger problems.

Meanwhile his ingenuity and dominant creative and motive impulses did not permit him to rest satisfied with mere appreciation and exposition of conditions as they were. Several of his patents, showing more than ordinary insight and skill, attracted the attention of the Westinghouse Air Brake Company, and as a re-

sult he finally accepted the opportunity afforded by their offer to develop his ideas.

Having a rare combination of mechanical genius, intuitive perception of the essential practical limitations and requirements of the problems before him and untiring patience and persistence in a course once entered upon, he was particularly well equipped to lead in the engineering development whereby the broad principles and characteristic operative features of the air brake, fundamentally established by George Westinghouse, were expanded and increased to provide the greater flexibility, economy and safety which the rapid advancement in motive power and rolling stock design had made imperative, if the potential of these improved facilities was to be fully utilized.



WALTER V. TURNER.

In recognition of his signal accomplishments in the development and perfection of new apparatus, he was appointed mechanical engineer of the Westinghouse Air Brake Company in 1905. This was only two years after entering the company's employment and but eight years after leaving the New Mexico sheep ranch.

High speeds, heavy trains and the necessity for economical and safe control having created new requirements in the electric railroad field, Mr. Turner early recognized the limitless possibilities in this direction and led to the development and perfection, in rapid succession, of several improved systems of braking devices and air compressor control for electric traction service. He has perceived clearly the practical requirements of existing conditions, the trend of future de-

velopments and the latest commercial possibilities of improved facilities in braking devices in steam railway service and more especially in the more diversified and specialized classes of electric traction service. The secret of his success lies largely in his profound conviction of the potency of facts and principles when properly presented to carry conviction and result in a logical sequence of action.

Conspicuous examples of Mr. Turner's work are the "ET" equipment now generally standard for steam and electric locomotives; the quick service and uniform release triple valve, almost universally used for freight service; the "empty and load" brake for freight cars, in use for several years on the Santa Fe, Southern Pacific, Bingham & Garfield and Virginian Railways; the improved passenger car brake equipments made standard on many of the leading roads of the country; the semi-automatic and combined automatic and straight air traction brake equipments for city and interurban service; and the more highly specialized and efficient systems of pneumatic and electro-pneumatic brakes in successful operation for several years on the lines of the Boston Elevated System and the Chicago Elevated Railways; the subways in Philadelphia and New York; the New York, New Haven & Hartford and Pennsylvania Railroad electrified zones, and the New York Municipal Railway. The equipment developed for the cars of the last mentioned railroad represents the highest development in electro-pneumatically controlled brake apparatus arranged to regulate the retarding force according to the total loaded weight of the car at the time of stopping, including all of the features making for efficiency, economy and safety of operation that experience with previous developments had shown to be practicable.

Mr. Turner has constantly contributed to the advancement of the art of braking along scientific and educational lines by numerous magazine articles and addresses before technical and engineering clubs, societies and colleges. His addresses have been features of the annual conventions of the National Air Brake Association and the Traveling Engineering Association for several years. His "Letter to Urban," published in the *Electric Journal* in November, 1913, presents his philosophy of life, and is typical of his interest in young men and his inspirational appeal to their energy, enthusiasm and loyalty. To this array of literary work must be added his instructive series of articles on air brake subjects now appearing in the pages of

RAILWAY AND LOCOMOTIVE ENGINEERING, and which are attracting wide attention among railway men.

In 1910 Mr. Turner was appointed chief engineer of the Westinghouse Air Brake Company, and in 1914 advanced to the position of assistant manager in charge of engineering. He was given a special testimonial by the Air Brake Association in 1912 in appreciation of his services to that association and his contributions to the cause of humanity and science. He was awarded the Edward Longstreth Medal of Merit (in 1910) and the Elliot Cresson Medal (in 1912) by the Franklin Institute (the latter medal being the highest honor in the gift of the institute) "for his air brake inventions and developments." But perhaps more highly prized than all these, because it was the first and is most intimately connected with the motives actuating and the results achieved by his efforts, is a testimonial presented by the Brotherhood of Locomotive Engineers of the Western Grand Division of the Santa Fe Railroad testifying to their appreciation of his ready aid at all times of need and his success in improving the air brake conditions on that road, whereby "the old fear and dread to tip the crest of our mountains has passed away."

#### Inspection of Locomotives.

An open competitive examination for inspector of locomotives will be held on May 3 and 4, at the places specified on Application Form 1892, copies of which may be had from the United States Civil Service Commission, Washington, D. C. The salary is \$1,800 per annum and expenses when absent on official duties. As now organized the territory of the United States is divided into fifty inspection districts, and appointments may be made of the highest eligibles examined in that district, except that certification may be made of the highest eligibles in the entire country who have expressed willingness to accept appointment where the vacancy exists. Photographs taken within two years must be pasted in the space provided on the admission cards sent them after applications are filed. Tintypes or proofs will not be accepted.

#### The Wabash Has Cars to Burn.

Before the latter part of July the Wabash railroad expects to burn at Decatur approximately 4,000 box cars and coal cars. Already 1,000 have been burned. These cars have been in service for about twenty-five years and some are still in active operation, with their defects patched up. The Wabash expects to order some modern cars in the near future. The new cars will be of the latest design, and of heavier and better material.

## H. B. Underwood & Co. Portable Milling Machines

Among the many popular machine tools constructed by H. B. Underwood & Company, Philadelphia, Pa., the portable milling machine shown in the accompanying illustrations has won an enviable reputation both for its adaptability and durability. This machine is designed and built

der side of bed to the clamp brackets and is ready for work. For convenience in handling, the spindle and rim can be readily removed. The spindle is bored for the Morse standard taper for small cutters, and threaded nose for large cutters.

No machine shop, and especially rail-

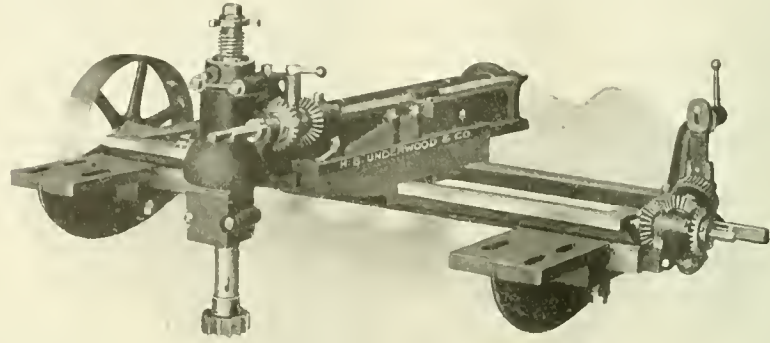

especially for facing steam engine valve seats in solid steam chests, but has also been found useful for a wide range of various kinds of work where it is easier to take a portable machine to do the work than to take the work to the shop.

It is strongly geared and has power feed in both directions and can be used in any position, horizontal, vertical or inclined.

road repair shop, is complete without one or more of these machines. The materials are all of the best and the design is so simple and substantial that there is literally nothing to get out of order. There are a variety of sizes and every machine is guaranteed to do good work and do it quickly.

In the machine illustrated the length of

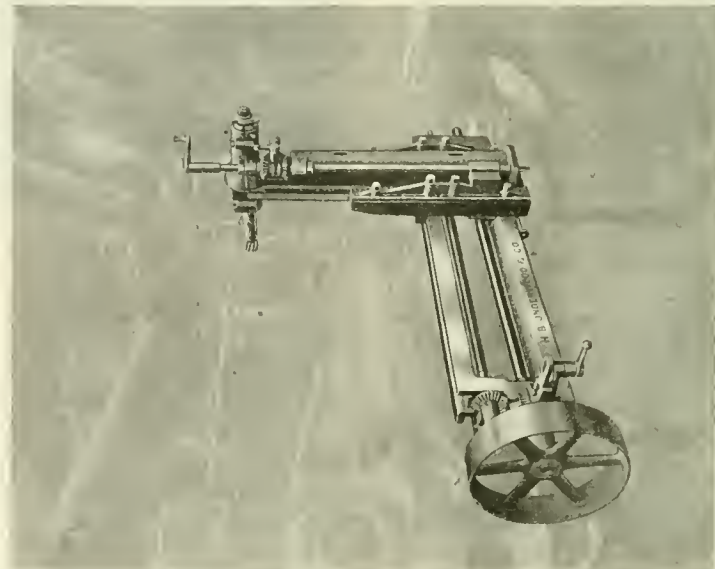

It does rapid and accurate work and will face a valve seat 22 inches by 40 inches by 7 inches deep. It can be run by hand wheel, small steam engine, air or electric motor. It can be easily attached to any steam chest after the steam chest cover and valve have been removed.

The clamp brackets furnished are bolted fast with the steam chest studs. The machine is then bolted by T slots on un-

der side of bed to the clamp brackets and is ready for work. For convenience in handling, the spindle and rim can be readily removed. The spindle is bored for the Morse standard taper for small cutters, and threaded nose for large cutters. The diameter of the spindle is 1 3/4 inches and the diameter of the driving shaft 1 1/8 inches. The diameter of the feed screws is 7/8 inch. The weight of the standard size machine is 700 pounds and when boxed and packed weighs approximately 800 pounds.

## Smith-Ward Automatic Slack Adjusters Applied to New York Railway Cars

The new cars of the New York Municipal Railway and 15 new cars of the New York, Westchester & Boston Railway have been equipped with automatic slack adjusters furnished by the Smith-Ward Brake Company, New York, and their action is reported to be of the most reliable kind. The general details of the device are shown in the accompanying drawing. The shim box of the adjuster is at "A," the bifurcated push rod, which goes under the shims in the shim box is attached between the double levers at "B." The adjusting rod which makes the adjuster automatic is shown at "D," connecting "C" and bolt through "B." At "C," on the slotted end of the adjusting rod, there is a washer and volute-spring drawn down by a bolt, so as to give a certain amount of friction. The hole through the adjusting rod at "B" is round, with a slight elongation to give shoe clearance—it not having the long slot in it as has the bottom rod bar connecting the lower ends of the levers. Upon the application of the brakes, both the line lever and the dead lever move

time it is necessary to touch them for the adjustment of the brakes is when new shoes are required. When it is necessary to apply new shoes, all that is required is to take a small block of wood about 5 ins. long,  $\frac{3}{8}$  ins. thick and 4 ins. or 5 ins. wide, insert it in the slot on the bottom of the shim box "A," raising up the shims and pushing in the box toward the wheel, so that the bifurcated push rod at "B" goes under the shims to the back of the shim box. This will give enough slack so that the old shoes may be removed and the new ones put in. To adjust the brake, then all that is necessary is to make one regular application, when the adjusters will take up the slack, adjusting the shoes in their proper relation to the wheels so that they will be close up to the wheel, but still allow the car to coast freely, and piston travel will be down to a minimum.

### Car Construction.

In a discussion on the merits of wooden and all-steel car construction Mr. James

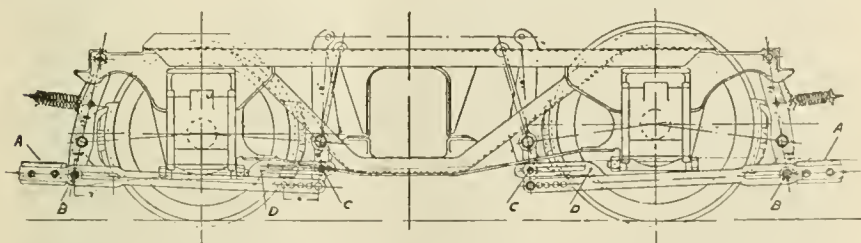

DETAILS OF SMITH-WARD AUTOMATIC SLACK ADJUSTER.

toward each other. Adjusting rod "D" slips toward the center of the truck, under the friction device at "C," the amount possible less the amount of the elongation of the hole of said rod at "B."

Upon the release of the brakes, if there is any slack, except what is required for shoe clearance, and provided for at "B," the bifurcated push rod at "B" pulls out of the shim box "A," allowing some, one or more, of the shims to fall down behind it, thus permanently shortening the distance between the two levers. This operation continues as the shoes wear and the brakes are applied, adjusting rod "D," always moving toward the center of the truck past "C," on the applications of the brakes, and upon the release of the brakes the push rod at "B" always moving out of the shim box, allowing more shims to fall down behind it until the shoes are worn out. Then the shims are raised up in the box so that the push rod is pushed in under them again. New shoes are applied and the operation starts over again.

With these slack adjusters the only

Coleman, superintendent of the car department of the Grand Trunk system, said that the older steel cars are now showing deterioration at the rivet holes. This is a natural result, as the cars get older this defect will become more prominent and will sound like rattle boxes in time. Some railroads are dispensing with the all-steel interior finish, and some are considering also the exterior to be of wood applied to a steel frame.

Many roads in the States are considering which is the most economical. Some use steel on the outside that does not last one half as long as the wooden exterior, for the reason that the steel sheets become thin through corrosion and last only a few years. The wood exterior finish will last indefinitely. The car with the wooden exterior finish painted properly will last approximately eight years, and the cost of repairing will be about \$165. On the other hand, it will cost about \$500 to apply steel interlock sheathing and paint on the outside.

Of all the roads that have all-steel cars to-day there are only three or four that

are in a position to properly maintain those cars. The use of an all-steel underframe is strong enough to resist telescoping. The car should have a wooden interior and a wooden exterior, with steel frame and all-steel ends, and a canvas roof, which is the most economical and the best to apply to passenger cars. We have seen some of these roofs in service for forty years. This is remarkable service compared with the all-steel roof which will not last one-third as long as the canvas roof.

The all-steel coach is fitted with upholstery, the clothing on the passengers and the hand-baggage they carry in their hands is all more combustible than the wooden interior finish. In sleeping cars you have similar combustible materials, only in larger quantities. The all-steel car as a protection against fire is an exploded idea. There is very little in it when you analyze it, practically. Railways are now confronted with the question of which is the most economical car to build and which will give the greatest factor of safety to the travelling public. The most satisfactory car is the composite car with steel underframing that will withstand shocks of 400,000 pounds, having a wooden interior and exterior finish.

### The Damascus Swords.

Among the workers in steel there has always been an air of mystery about the forging and machining of that ancient sword—the Damascus blade. Blacksmiths who are familiar with the forging of swords and bayonets say that fine grained steel is not the best for either.

Very curious stories are told about the Damascus blades, of the way in which they are made, the process of tempering them, and of their superior qualities; but the tales are now old. Years ago N. P. Ames, a noted armour maker of New England, visited Spain with specimens of his handiwork. When the authorities there produced their finest specimens of their armories, a sword that was particularly famous was tested in competition with those of Mr. Ames, and the New England product was found superior to the Damascus blade.

### To Remove Iron Rust.

A method of removing rust from iron consists in immersing the articles in a bath consisting of a nearly saturated solution of chloride of tin. The length of time during which the object should remain in the bath depends on the thickness of the coating of rust, but in ordinary cases twelve to twenty-four hours will be sufficient, the user learning from a little practice the proper time required. On taking the articles out of the bath they should be washed in water and afterwards rinsed in ammonia.

# New Type of Powerful 48-Inch Car Wheel Borer, With or Without Hub-facing Attachment, Adapted for Either Counter Shaft or Motor Drive

The degree of perfection which has been attained in the construction of many of the larger machines used in railroad repair shops is well illustrated by some of the recent products of the Niles-Bement-Pond Company, New York. In the accompanying illustrations two views are given showing the company's latest designs of 48-inch car wheel borers which are meeting with universal approval in many of the leading railroad shops in America.

The chuck capacity is for wheels from 26 to 48 inches in diameter on the treads, but on reversing the jaws smaller wheels can be taken. The roughing and finishing tools of the bars are arranged so that the roughing tool goes through the wheel hub before the finishing tool enters. The table spindle has an adjustable taper bushing so that the inevitable wear of the spindle can be taken up at any time and still retain its perfect alignment. There is attached to the bottom of the table spindle an adjustable collar with a bearing against the bed to take the upward thrust of the table, should it tend to lift.

A self-centering universal chuck is fitted in the table and is operated by the motion of a cam lever that gives sufficient movement for firmly gripping the wheel. The machine is regularly equipped with a three-jaw chuck, but a five-jaw chuck, as shown in the illustrations, is also furnished at a small extra cost. For the purpose of tightening the chuck there are three shafts squared to receive a wrench, and one is always sure to be within easy reach of the operator when the table is stopped. The bar is of great strength, being 8 inches in diameter, with a traverse of 35 inches, and is correctly counterbalanced, and has rapid traverse by a large hand-wheel.

There are four feeds provided for the boring bar,  $\frac{1}{8}$ ,  $\frac{3}{16}$ ,  $\frac{3}{8}$  and  $\frac{9}{16}$  inches. The feeds are changed by two levers conveniently within easy reach of the operator. As will be noted in the second illustration a hub-facing attachment may be fitted to the machine if desired. The hub-facing bar is fed from the center toward the outside of the wheel and may be operated at the same time that the main boring bar is feeding down. The hand-wheels for operating the traverse of the bar and the feed clutch are located on the operating side of the machine, and the tool slide is also conveniently adjusted from the operator's position by means of a socket wrench.

The handling of the wheels is accomplished by a drum type crane as shown

in the illustrations or by a pneumatic crane if preferred. Both are conveniently located and are rapid and reliable in operation. The drum type crane is controlled by friction clutches operated by a conveniently placed lever; and no harm can be done if the wheel is lifted to its highest position in the event of the op-

erations per minute. There are no less than six table speeds, ranging from 12 to 30 revolutions per minute. When the drum type of crane is furnished, there is provided a separate countershaft with an 18-inch diameter pulley for a  $2\frac{1}{2}$ -inch belt, furnishing a run of 320 revolutions per minute. The variable speed motor

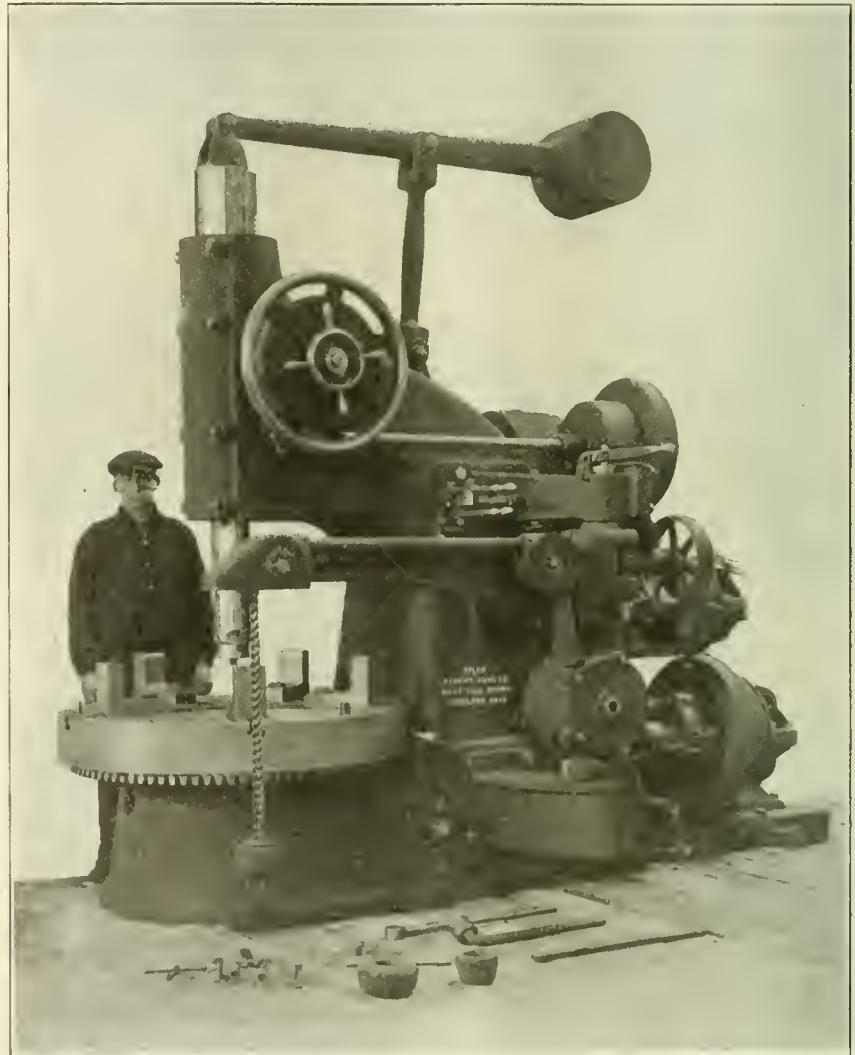

48-INCH CAR WHEEL BORER.

erator failing to throw out the clutch. The pneumatic crane is also readily controlled by a suitable valve within easy reach of the operator.

It may be added that there is also a variety in the driving appliances. The belt drive is by a two-speed countershaft and three-step cone for a 4-inch belt. The maximum diameter of the cone is 26 inches and the minimum 18 inches. The countershaft pulleys are 20 inches in diameter, and run at speeds of 225 and 270

drive is by a 15-horsepower motor, 3 to 1 variable speed. When the drum type crane is furnished, it is operated by a 3-horsepower speed motor.

The ground space occupied by the machine is 10 feet in length, width 10 feet, while the extreme height is 11 feet. It is scarcely necessary to add that the materials are of the best, and with the recent improvements in high-speed tool steels, the output of these fine machines will not likely be surpassed in our time.



**Filling or Stopping Castings.**

In a recent issue of the *Practical Engineer* of London, Mr. W. J. May writes: "For various reasons it often is necessary to stop or fill holes in castings, and provided that the article is not one in which strength is of importance, stopping may be resorted to. If strength is of first importance, a faulty casting should be scrapped right away, as it is always a source of danger. In no case is there any reason why castings should need stopping, because they can always be produced solid, although this may at times

ing material, and they are applied hot. They hold very well if the shape of the hole admits of their having a chance. Where the shape of the hole is such that ordinary fillings will not hold readily, some other hard-setting material must be used, and this must stick to the metal by reason of some adhesive material in its composition. A good filling of this kind is composed of 12 lb. dry white lead, 3 lb. red lead, 3 pints hard varnish, ½ pint japanner's gold size, ½ pint boiled oil and 2 lb. very finely rubbed bath-brick, the whole

to drill out the holes and tap them, screwing in plugs of the metal to make a sound place. A fine thread must be used and a really tight fit must be made. This does not increase the tensile strength of a casting necessarily, but carefully done it makes a sound mend and will bear friction equally with the other parts of the casting. Where castings have to be finished smooth with an enamel paint and have too rough a skin, the surface can be filled and rendered smooth by a thick paint made with white lead and equal parts of gold size and hard drying varnish as a medium. Two or three thin coats of this will, when set hard, allow of rubbing down smooth, and the enamel will form a smooth glassy surface. It is not likely to scale or peel off under ordinary conditions. It also gets harder with age, a point of some importance in many cases. Generally, castings should be sound and smooth and not want filling, but such operations are sometimes unavoidable.

**"There Goes 'Bobby'!"**

The strangest monument perhaps that any man has ever had is a small accommodation train that runs between Yates Center and Fort Scott, Missouri, on the Missouri Pacific Railway. It is not known as "the 9:15" or "the 8:43," but always as "Bobby." And "Bobby" is the name of a man who managed, in his humble capacity as conductor on this line, to endear himself to an astonishing number of people.

For twenty years Bobby Reeves—nobody ever called him Robert—was conductor of the morning Missouri Pacific train that ran along this route. Most of the time the train went as far east as Rich Hill, but later its run was terminated at Fort Scott. Reeves was a big, jovial man. He always had a kindly smile for the country boy who was taking his first ride "on the cars"; he could chuck a crying infant under the chin and bring an immediate smile to its wry little face, and he could swap a joke with any drummer along the line. After a while almost everybody along that portion of the road came to know Bobby Reeves and call him friend. Perhaps he made a few enemies, too, but if he did they were of a remarkably silent sort, for nobody ever seems to have heard of them.

Last winter Bobby Reeves died. About the same time the Missouri Pacific took off the morning train along that route. There was an immediate protest against the road's action by every town along the line. The train probably was not badly needed, but it had come to be a sort of institution, and folk did not want to part with it. After a while the Missouri Pacific restored it in accommodation form. The long-familiar figure of the smiling old conductor is gone now, but folk look after the train a bit wistfully and say, "There goes 'Bobby'!"



CAR WHEEL BORER, SHOWING HUB-FACING ATTACHMENT.

involve the use of some form of oxidant flux. In fact, if such fluxes are properly made—and this can be done both easily and cheaply—the castings can be produced to give absolute soundness with the maximum of strength. The shape of the hole to be filled has much to do with the success secured, and it may be that the ordinary fillings supplied by the foundry supplies people will not hold firmly unless holes are drilled to afford a more or less effective keying. Usually such things are made with borings, sulphur, and some color-

being kneaded into a thoroughly mixed homogeneous paste or dough. As this filler will not keep for any time, it should only be made in sufficient quantities for immediate use. In applying it, the holes should be brushed over with gold size about twenty-four hours before being filled, and after filling the castings should be kept in a moderately warm place until the filling is hard. The filling can be colored with black lead or lamp-black for iron or with chrome yellow for brass, and holds very firmly. In some cases, instead of using fillings, it is the better plan

# Electrical Department

## Performance of Electric Locomotives on the Norfolk & Western Railway Pacific Coast Electric Railways, Etc.

It is interesting to note the marked success that has attended the electrification of the Norfolk & Western at the Elkhorn grade. In less than one year the capacity of that difficult section of the road has been more than doubled. Under the old conditions three powerful Mallet locomotives were used in hauling 45 cars weighing about 75 tons each. The grades run as high as 2 per cent. and extend to nearly 10 miles. The average speed of the steam locomotives did not exceed 8 miles per hour. One electric locomotive does the work of 3 Mallets, 12 of the electric type of locomotive having replaced the work of 33 Mallets at an average speed of 28 miles per hour.

As described in our pages at the time of the installation of the electric locomotives last year, the single-phase system is

stance that the use of electric braking has ever been attempted for heavy freight service, and experience has shown its complete success under the most trying conditions.

These twelve 270-ton Baldwin-Westinghouse locomotives consist of two 135-ton units or halves. Each unit has two main trucks connected by a Mallet type hinge, and each main truck has two driving axles included in a rigid wheel base, with a radial two-wheeled leading truck. The bumping and pulling stresses are transmitted through the main truck frames and through twin draft rigging mounted on the main trucks at each end of the unit. The cab is of the box type, and is supported on the main truck entirely by spring-cushioned friction plates, there being no weight on the center pins, which

inspection, making a continuous service of 22 hours a day. There is also a considerable saving in the wear of brake-shoes, wheels and tires as compared with the steam locomotives.

It is also worthy of note that the engineers who were transferred from the steam locomotives to the electric engines are all well satisfied with the change, and in no case has any one of them shown a desire to return to the steam locomotives, but took to the new job good-naturedly, and, to all appearances, seem to be in better physical condition than when they were employed on the big Mallets. The exact comparison of costs will likely be published at the end of the first year and will be of general interest to all engaged in heavy transportation.

The following are the principal dimen-

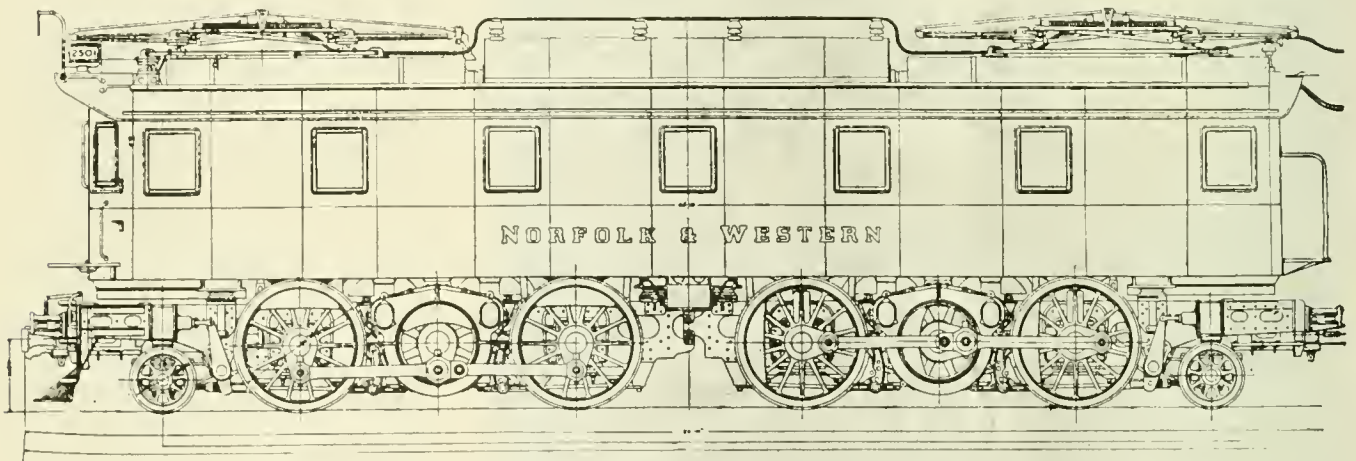

ELEVATION VIEW OF ELECTRIC LOCOMOTIVE, NORFOLK & WESTERN RAILWAY.

used, power being generated, transmitted and distributed single phase at 25 cycles and collected from the overhead catenary trolley contact system at 11,000 volts. The locomotives are unique, however, in that they are equipped with phase converters, which, in connection with the main step-down transformers in the locomotive, transforms the single-phase power of the trolley to three-phase power for use in the three-phase induction type traction motors. Another feature is that without the use of complicated apparatus it is possible to utilize the locomotive for electrically holding or braking trains at constant speed while descending grades. This utilizes the energy in the moving train descending the grade to drive the motors as generators and thus return energy to the line. This is the first in-

serve only to maintain the cab in its proper position on the trucks. Each locomotive is provided with eight traction motors of the three-phase induction type, with wound secondaries for four-pole and eight-pole operation. The motors are force-cooled by air from the main ventilating duct, which also delivers air to the phase converter and to cooling towers for the liquid rheostat.

Returning again to further comparisons between the electric locomotives and the Mallets which they replaced, apart from the power and speed features there is a great saving in repair work. The Mallets were frequently undergoing running repairs, besides the general inspection, cleaning of fires, replenishing coal and water. The electric locomotives have frequently run ten days without any general

sions and weight of these locomotives:

Length over-all—105 ft. 8 ins.

Driving wheel base—83 ft. 10 ins.

Rigid wheel base—11 ft.

Truck wheel base—16 ft. 6 ins.

Height, rail to pantagraph locked—16 ft.

Height, rail to top of cab—14 ft. 9 ins.

Width over-all—11 ft. 6¼ ins.

Width over car body—10 ft. 3 ins.

Diameter of driving wheels—62 ins.

Diameter of truck wheels—30 ins.

Weight on drivers—220 tons.

Tractive effort—133,000 pounds.

Horsepower developed—6,700.

The construction of the power house, locomotives, line construction and signaling were carried under the supervision of Gibbs & Hill, consulting engineers, New York City.

### Pacific Coast Electric Railway.

This company operates an electric road between Guadalupe on the Southern Pacific Company's line between San Francisco and Los Angeles and Santa Maria. Santa Maria being on the Pacific Coast Railway. (The Pacific Coast Railway is a steam railway operating between Port San Luis and Los Olivos.) The distance between Guadalupe and Santa Maria is nine miles, as nearly level as possible and a straight track. The substation is at the Santa Maria end of the line. The principal use to which this road is put is meeting the main line trains of the Southern Pacific Company, with a single steel passenger coach, equipped with Westinghouse narrow-gauge commutating-pole motors and HL control. These passengers are carried to and from Santa Maria. During a ninety-day period in the fall of the year the road handles sugar beets for the Union Sugar Company, other than this short interval of time no heavy traffic is handled.

Guadalupe is a town of 500. Santa

held in the Coliseum at Chicago last month. Among the most interesting apparatus exhibited was the pen drill automatic substation equipment for maintaining a continuous supply of power on a transmission line, or a service line, when two or more sources of electric supply are available; a standard section type switchboard for electric garages, train lighting and baggage truck charging, and general battery charging purposes; vacuum tube lightning arresters; a display of enameled resistance units; indoor and outdoor type air cooled transformers for low voltage signal lighting and portable testing instruments.

### Incandescent Headlights for Street Railway Service.

Extensive experiments made by the General Electric Company have shown that the selection of the incandescent lamp depends for the most part upon the available voltage supply and the possibility of sub-dividing this voltage. Since most railway work is direct current, we are

### Storage Batteries on the New York Central.

In the power houses that supply the electricity for moving the trains in the electric zone are large storage batteries. In these batteries is stored up energy sufficient to keep the trains moving for a very considerable period if anything goes wrong with the generating plant. Happily it is seldom necessary to use them; but they are there and ready if occasion requires. The company wouldn't be without them and run the risk of tying up the whole terminal zone in case of a stoppage of the machinery. Preparation has been made for the emergency whether it ever occurs or not.

### New Haven's Equipment Orders.

The expenditure of approximately \$10,500,000 for purchases the company has made or obligated itself to make constitutes a total of 1,236 units of equipment. This equipment has been ordered with the view of bringing the facilities of the

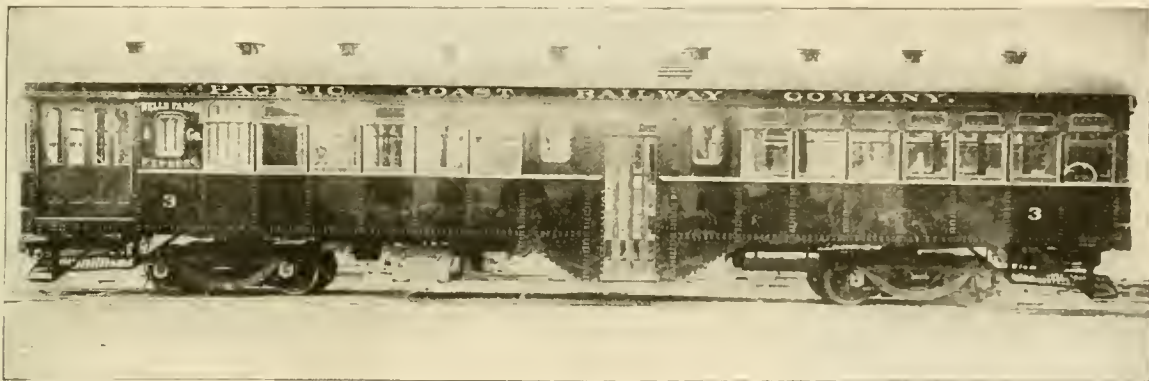

PACIFIC COAST ELECTRIC RAILWAY CAR EQUIPPED WITH WESTINGHOUSE NARROW GAUGE MOTORS AND HL CONTROL.

Maria a town of 2,500. There are no towns between them, excepting for the passenger business and the sugar campaign (during the harvest season of the sugar beets known as the sugar campaign), there is no other source of revenue for this road. This road has a number of feeders running into the beet field, but the trains are gathered by means of steam locomotives on to the main line of the Pacific Coast Electric Railways, where they are hauled by means of an electric locomotive to the branch running through the Union Sugar Company's plant where they are again hauled by steam locomotives. This gives a general idea of the railway and a little of the conditions under which they operate.

### General Electric's Exhibit.

A very interesting exhibit was made by the General Electric Company at the Railway Appliances' Association convention,

limited in the smaller headlights to the incandescent lamp which has the same wattage as the lamps which light the car or a multiple thereof. Thus, if 23-watt lamps are used for lighting the car, the headlight should take either 23, 46, 69 or 92-watt lamps. However, the nearest standard lamps to the 69 and 92-watt are 72 and 94-watt lamps, which may be used satisfactorily under these conditions. For higher powered incandescent headlights for interurban service, lamps of this rating will not give sufficient track illumination, and we are, therefore, obliged to use a lamp of higher candle-power. The majority of railways have been using 4-amp. arc headlights for interurban service. These headlights consume 80 volts at the arc, and are operated in series with external resistance. For this reason, we have developed an 80-volt, 4-amp. incandescent lamp, which can be operated in series with resistance already installed on the cars.

company up to the standards required by the business of New England. Of the 1,236 units that have been ordered in the twenty-eight months from September 1, 1913, to the beginning of the present year, 477 units have already been delivered. These include 3 electric locomotives, 171 coaches, 39 smokers, 100 baggage cars, 15 baggage and mail cars, 20 baggage and smokers, 6 club cars, 15 milk cars, 15 postal cars, 50 cabooses, 1 crane, 1 wrecking crane, 15 multiple unit motors and 26 multiple unit trailers. There are 759 units that have been ordered but have not yet been delivered. Included in this list are 80 steam locomotives, 63 coaches, 35 baggage cars, 500 coal cars, and 50 refrigerator cars. Orders have also been placed for 25 milk cars, 2 diners, 2 funeral cars and 2 multiple unit motors.

The remaining orders are expected to be nearly filled during the present year.

# Items of Personal Interest

Mr. F. Bull has been appointed foreman of the machine shops of the Southern Pacific at Tucson, Ariz.

Mr. J. H. Rosenbaum has been appointed general foreman of the Illinois Central, with office at Clinton, Ill.

Mr. C. A. Matmiller has been appointed roundhouse foreman of the Northern Pacific, with office at Helena, Mont.

Mr. G. W. Henry has been appointed road foreman of engines of the Baltimore & Ohio, with office in Cleveland, Ohio.

Mr. Louis D. Moore has been appointed electrical engineer of the Missouri Pacific, with office at St. Louis, Mo., succeeding Mr. C. Garner.

Mr. B. P. Johnson has been appointed master mechanic of the Seattle division of the Northern Pacific, with office at Seattle, Wash.

Mr. A. C. Adams has been appointed master mechanic of the Virginia division of the Seaboard Air Line, with office at Raleigh, N. C.

Mr. F. McCarra has been appointed master mechanic of the Illinois Southern, with office at Sparta, Ill., succeeding Mr. G. A. Gallagher, deceased.

Mr. Philip H. Coniff has been appointed assistant superintendent of motive power and machinery of the Florida East Coast, with office at St. Augustine, Fla.

Mr. W. G. Willcoxson has severed his connection with the Garrett-Callahan Company, and accepted a position with the Boss Nut Company of Chicago.

Mr. H. E. Warner has been appointed superintendent of shops of the New York Central Lines west of Elkhart, Ind. He was formerly general foreman at the same place.

Mr. M. R. Smith has been appointed master mechanic of the Lehigh Valley, with office at Wilkes-Barre, succeeding Mr. W. G. Barrows, assigned to other duties.

Mr. H. E. Greenwood has been appointed master mechanic of the Indiana division of the Baltimore & Ohio Southern, with office at Seymour, Ind., succeeding Mr. E. A. McMillen.

Mr. B. B. Edison, formerly road foreman of locomotives of the Grand Trunk Pacific at Smithers, B. C., has been appointed road foreman of locomotives on the same road at Regina, Sask.

Mr. J. E. Quigley, formerly general foreman of the Ohio & Southwestern at East St. Louis, Ill., has been appointed master mechanic of the Baltimore & Ohio Southwestern, with office at Flora, Ill.

Mr. R. F. Harrill, formerly general foreman of the Southern at Charleston, has been transferred to a similar position on the same road, with office at Greenville, S. C., succeeding Mr. J. C. Dunham.

Mr. T. W. Coe, formerly superintendent

of shops at Elkhart, Ind., of the New York Central Lines west of Buffalo, has been appointed master mechanic of the Indiana Harbor Belt, with office at Gibson, Ind.

Mr. H. J. Warthen, formerly master mechanic of the Richmond, Fredericksburg & Potomac at Richmond, Va., has been appointed superintendent of motive power of the same road, succeeding Mr. W. F. Kapp.

Mr. S. West, formerly master mechanic of the Canadian Pacific at Kenora, Ont., has been transferred to Medicine Hat, Alta, succeeding Mr. R. Brown, who has been appointed a lieutenant of the Canadian forces.

Mr. W. S. Gray has been appointed general foreman of the Louisville & Nashville at Covington, Ky., and Mr. James Mayhall has been appointed day roundhouse foreman at the same place, succeeding Mr. Gray.

Mr. James W. Brookhart, formerly master mechanic of the Cotton Belt Lumber Company, has been appointed master mechanic of the Thornton & Alexandria, with office at Thornton, Ark., succeeding Mr. W. M. Taylor.

Mr. W. B. Embury, formerly master mechanic of the Chicago, Rock Island & Pacific at Valley Junction, Iowa, has been transferred to Estherville, Iowa, succeeding Mr. W. T. Fitzgerald, who has been transferred to Manly, Iowa.

Mr. A. Brown, formerly locomotive foreman of the Canadian Pacific at Ft. William, Ont., has been appointed district master mechanic on the same road with office at Winnipeg, Man., succeeding Mr. A. Peers, transferred to Moose Jaw, Sask.

Mr. G. H. Langton, formerly master mechanic of the Seaboard Air Line at Raleigh, N. C., has been appointed shop superintendent of the Portsmouth, Va., shops, succeeding Mr. L. D. Freeman, granted leave of absence on account of ill health.

Mr. R. N. Millice has been appointed assistant locomotive superintendent of the United Railways of Havana, at Cienaga, Cuba, succeeding Mr. C. F. Roberts, deceased, and Mr. John P. Risque has been appointed mechanical engineer, with office at Havana.

Mr. H. C. Oviatt, formerly assistant mechanical superintendent of the New York, New Haven & Hartford, at New Haven, Conn., has been appointed superintendent of the Shore Line division, with office at New Haven, succeeding Mr. J. D. Gallary.

Mr. E. H. McGovern has been appointed resident engineer of the Cleveland, Cincinnati, Chicago & St. Louis, and Mr. A. M. Turner has been appointed district

engineer in charge of track elevation on the same road, both with headquarters at Columbus, Ohio.

Mr. E. J. Pearson has been appointed a vice-president of the New Haven road, with headquarters in Boston. He will act as a general assistant to Mr. Elliott, and in particular will have charge of all matters relating to construction, operation and maintenance.

Mr. J. P. Stow, Jr., has been appointed master mechanic of the New London division of the New York, New Haven & Hartford, with office at Midway, Conn., and Mr. James B. Wyler has been appointed master mechanic of the Midland division of the same road, with office at Boston, Mass.

Mr. Emerson McMillin, chairman of the board of directors of the American Light & Traction Company, of New York City, has founded two scholarships in the new school of engineering of the University of Detroit, the scholarships to be awarded by the faculty of the school. The industries controlled by Mr. McMillin's company employ many electrical, mechanical and civil engineers and it is his purpose to promote opportunities for the young men of Detroit and vicinity.

The Franklin Railway Supply Company, due to the remarkable results secured by the use of the Stone-Franklin Lighting Equipment, has appointed Mr. Ralph G. Coburn sales manager of their electrical department. Mr. Coburn has been associated with the Franklin company for the past seven years, being formerly in charge of their Chicago office and for the last few years eastern sales manager, with headquarters in New York, where he will continue in his new capacity.

Mr. A. O. Swift, recently appointed signal supervisor for the Chicago district of the Chicago, Milwaukee & St. Paul, entered the service of that road in 1898 in the bridge and building department. In 1906 he was transferred to the signal department and in 1909 appointed assistant signal foreman of the Chicago district. In 1910 he was appointed district signal foreman for the Chicago district, and when the Chicago district was recently made a supervisor district, Mr. Swift was appointed signal supervisor.

Mr. W. W. Lowe, superintendent of transportation of the Cumberland & West-ernport Electric Railway, of Cumberland, Md., has been promoted to the construction department of the New York offices of the Doherty organization, and will have his headquarters at Frostburg, Md., for the next six months, where he will be available for calls to other traction properties controlled by Doherty & Company. Mr. Lowe's duties as superintend-

ent have been assumed by Mr. B. Waller Duncan, general manager of the company.

After thirty years in the service of the Baltimore & Ohio Railroad, Mr. J. Walter Coon, assistant to general manager, has resigned to become associated with Mr. W. H. Williams, vice-president of the Delaware & Hudson, chairman of the board of directors of the Wabash, chairman of the executive committee of the Missouri Pacific and a member of the reorganization committee of the Pere Marquette, president of the Delaware Coal Company and a director of several trust companies. Mr. Coon entered upon his new duties last month, with headquarters in New York.

Mr. James E. Turk has been appointed general superintendent of the Philadelphia & Reading, with office at Reading, Pa. Mr. Turk has had considerable experience in the engineering department in a number of the western roads and from 1889 to 1899 was supervisor of tracks and buildings on the Philadelphia and Reading at Pottsville, Pa. From 1899 to 1901 he was division engineer on the same road at Reading, Pa. He has also acted as superintendent on the Wilmington & Columbia division, and from May 1, 1903 to the present date superintendent in the Shamokin division of the same road at Tamaqua, Pa. He is succeeded by Mr. R. Boone Abbott.

Mr. Edwin H. Baker has retired as second vice-president of the Galena Signal Oil Company. He has been engaged in the manufacture and supply of lubricating oils for the past 43 years. In 1873 he en-

ness was consolidated with the Galena Signal Oil Company. Mr. Baker had become connected with the Galena company in 1894. Upon the consolidation of the two companies, Mr. Baker was elected second vice-president of the Galena company.

Mr. E. Averill, who has been elected vice-president of the Locomotive Feed



GEORGE H. DUGGAN.

Water Heater Company just established in this city, is a native of New York State, and a graduate of Cornell University in the mechanical engineering classes, and has been a specialist in railway engineering. He has been engaged on several of the leading railways, and has also been prominently identified in an editorial capacity with several of the engineering periodicals. Latterly he filled the position of engineer of operation of the Standard Stoker Company. He is a thorough all-round railway man and brings to his new position a wide knowledge of railway matters polished by experience and calculated to illustrate and emphasize the merits of any meritorious device with which he may be identified.

Mr. Samuel G. Allen has been elected president of the Franklin Railway Supply Company, and Mr. Joel S. Coffin, formerly president, is now chairman of the board. Mr. Allen has served as vice-president since the incorporation of the company. He was born in 1870 at Warren, Pennsylvania, and was educated there and at Pennsylvania State College. He was plunged into business responsibilities immediately after leaving college, and found time to study law in a period of intense business activity. He was admitted to the bar in Warren County, Pennsylvania, and practiced law for nine years. In 1901 the Franklin Railway Supply Company was formed with Mr. Joel S. Coffin as president, and Mr. Allen as vice-president. The ability of Mr

Allen as a lawyer and as a business man is reflected in the success of the large number of concerns with which he is connected as an officer and director.

Mr. Charles H. Ewing, who has been appointed general manager of the Philadelphia and Reading is from Chester County, Pa. He entered the service of the Philadelphia and Reading in 1883, and has been consecutively rodman with engineering corps, constructor department, transitman, assistant engineer in charge of construction and maintenance. From 1889 to 1892 he was roadmaster, and from 1892 to 1893 division engineer of the same road. From 1893 to 1902 he was chief engineer of the Central of New England. July, 1902, to June, 1905, division engineer Reading and Lebanon division of the Philadelphia and Reading. June, 1905, to 1910, engineer maintenance of way of the same road at Reading, Pa. 1910 to 1913, superintendent of the Atlantic City road at Camden, N. J., and from January 1, 1913, to the present date general superintendent of the Philadelphia and Reading. He is an engineer of approved ability and wide experience.

The Board of Directors of the Philadelphia and Reading has elected Mr. Agnew T. Dice, president of the company, succeeding Mr. Theodore Voorhees, deceased. Mr. Dice entered the service of the Pennsylvania road at an early age. From 1882 to 1887 he was assistant engineer, and served sometime on the signal department on the same road. In 1893 and 1894 he was superintendent of signals on the New York Central, and from



SAMUEL G. ALLEN.

1894 to 1897 he was superintendent on the Atlantic City road. In 1897 he was appointed assistant superintendent on the Reading division of the Philadelphia & Reading and latterly superintendent on several divisions of the same road, and from 1903 to 1910 general superintendent



E. A. AVERILL.

tered the employ of S. T. Baker & Company, a firm which was founded by his father who was a large manufacturer of lubricating oils in New York. He was made president and general manager of the Baker company and continued to act in this capacity until 1912, when the busi-

on the same road. From Jan. 1, 1910, to the present date he has been general manager and latterly also vice-president on the same road. He is universally esteemed among railroad men, and is still in the prime of life.

Mr. George H. Duggan has recently been elected president of the Canadian Society of Civil Engineers. He is a graduate of the University of Toronto, and joined the engineering department of the Canadian Pacific in 1886. From 1891 to 1901 he was chief engineer of the Dominion Bridge Company. Later he was appointed assistant to the president and consulting engineer of the Dominion Steel Company and Dominion Coal Company, and from 1904 to 1910 was second vice-president and general manager of the latter company. In 1910 Mr. Duggan was appointed vice-president and general manager of the Dominion Bridge Company, a position he still holds. He is also chief engineer of the St. Lawrence Bridge Company, the contractors for the steel work of the Quebec bridge; vice-president of the Montreal Ammunition Company; and director of the Montreal Trust Company. He joined the Canadian Society of Civil Engineers in 1888, became a member in 1890, and was for ten years a member of the Council. In 1906 he was vice-president of the Canadian Mining Institution, being on the Council of the same society during 1911-13. He is also a member of the Institution of Civil Engineers, England, and of the American Society of Civil Engineers.

Mr. George M. Basford has been elected president of the Locomotive Feed Water Heater Company, with offices at 30 Church street, New York. The company will develop and handle for locomotive use the film heater designed and patented by Mr. Luther D. Lovekin, chief engineer of the New York Ship Building Company. The officers of the company already elected besides Mr. Basford are Mr. E. A. Averill, vice-president, and the incorporators embrace besides these officers Mr. Samuel G. Allen, Mr. H. F. Ball, Mr. Luther D. Lovekin, Mr. Joel S. Coffin, Mr. Le Grand Parish, Mr. J. E. Muhlfeld, Mr. George L. Bourne and Mr. V. Z. Caracristi. With this formidable array of skilled engineers and experienced business men, the success of the enterprise is a foregone conclusion. Mr. Basford, the president, has been so frequently mentioned in our columns that an extended notice of his interesting career is not necessary, but it may be reiterated that he has been connected with the engineering department of a large number of the leading railways, as well as with construction engineers, with all of which his work has been distinguished by a degree of thoroughness that showed the earnest student and accomplished engineer. He has also been

prominently identified with the engineering press, and is a writer marked by clearness and originality. He was also for a number of years assistant to the president of the American Locomotive Company, and for the last three years has been chief engineer of the Joseph T. Ryerson & Son Engineering Company. Mr. Basford is still in the prime of life, and one marvels how he has had time to fill so many important positions, but he seems to have preferred gathering experience in the wide field of railway engineering rather than to come to a stop in some safe siding. The best wishes of his numerous friends go with him in his new enterprise, and it may be added that in addition to assuming the presidency of the new and promising company referred to, Mr. Basford is also forming the G. M. Basford Company which will be devoted to handling the advertising



GEORGE M. BASFORD,  
President of the Locomotive Feed Water Heater  
Company.

accounts of a large number of railway supply houses. Mr. Basford is a New Englander by birth and education.

#### OBITUARY.

##### Theodore Voorhees.

The death is announced of Mr. Theodore Voorhees, for many years connected with the Philadelphia & Reading Railroad and president for the last two years, and vice-president for the preceding eleven years. Mr. Voorhees was born in New York in 1847, and graduated from the Rensselaer Polytechnic Institute, Troy, N. Y., in 1869 and entered the service of the Delaware, Lackawanna & Western in the engineering department. From 1874 to 1875 he was employed in the transportation department of the Delaware & Hudson Canal Company, and from 1875 to 1885, superintendent Saratoga and Champlain division of the same road, and

from 1885 to 1890 assistant general superintendent New York Central & Hudson River railroad, and from 1890 to 1893 general superintendent of the same road. In 1893 he became vice-president of the Philadelphia & Reading railroad, and latterly president as already stated. He was in the front rank of the progressive railway men, and introduced many improvements in the transportation system, especially in encouraging whatever was new and gave inventors an opportunity of testing their devices, and in this way was a leader in block signalling and safety devices generally. Among his associates his energy and enthusiasm was contagious, and at all times he seemed to be the right man in the right place.

#### A Red Cross Car on the Erie.

A Red Cross car, in charge of Dr. Wm. T. Davis, is now moving over the Erie system demonstrating "first aid" to employees. This service is furnished through the courtesy of the American Red Cross Society, and is proving of great interest and value. What should be done in case of accident is being explained as well as what not to do. Thus far demonstrations have been made at a number of the division points.

Naturally the movement of the car and what is being done has raised in numerous quarters the question: What is the Red Cross?

Briefly stated, the answer is this: It is a humane institution, and its objects are to give practical demonstrations in nursing and relief in times of war and on occasions of great disasters such as earthquakes, pestilence, fire, cyclones, mining accidents, floods, etc.

It is *not* a military aid, and in most countries is welcomed and respected, not as an auxiliary of any army or navy, but as a peaceful arm of humanity respected by all.

#### Fireless Steam Engine.

A fireless steam locomotive is used for switching cars and tie trams at an Ohio creosoting plant. The locomotive is of a type which was developed in Europe some years ago and is used around distillation plants, where cinders and live ashes would constitute a fire danger. This locomotive operates by steam, the boiler being charged about seven times every 24 hours at the main boiler, at 150 lbs. pressure. The maintenance cost of this type of switching engine is very low, and its use is said to be very satisfactory in a treating plant yard. Its tractive power is fully equal to that of the usual type, and although it weighs only 22 tons it has pulled as many as 12 loaded gondola cars at a time. Perhaps there are construction contracts on which a locomotive of this type would be an economy.

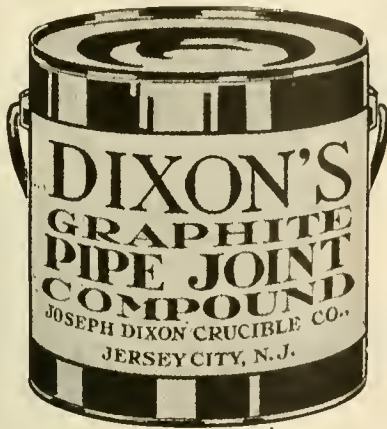

## DIXON'S GRAPHITE Pipe Joint Compound

Hard-set joints in pipe and fittings are impossible where this compound is used, because it never hardens or sets. The graphite lubricates the threads and prevents rust and corrosion — and it is easy at any time to unscrew a joint. At the same time an absolutely tight joint can be secured and maintained. Send for a sample and try it on any screwed or flanged joint, and on studs and bolts. Ask for a copy of "Valuable Graphite Products" No. 69-D.

Made in Jersey City, N. J., by the  
**Joseph Dixon Crucible Company**  
Established 1827

D-22

### RAILROAD EQUIPMENT NOTES.

The New York Central has ordered 72,000 tons of rails.

The Chicago, Burlington & Quincy has ordered 20,000 tons of rails.

The Great Northern has ordered 25 Mikado locomotives from the Baldwin Locomotive Works.

The Norfolk & Western has ordered 6 Consolidation locomotives from the Baldwin Locomotive Works.

The Delaware, Lackawanna & Western will build 10 switching locomotives in its own shops.

The Great Northern has ordered 258 tons of steel for four turn-tables from the American Bridge Company.

The Fort Smith & Western has ordered 3 Mikado type locomotives from the Baldwin Locomotive Works.

The Louisville & Nashville has ordered 47,000 tons of rails from the Tennessee Coal, Iron & Railway Company.

The Chilean State Railways have given the Osgood-Bradley Car Company an order for 24 passenger train cars.

The St. Louis & San Francisco is reported placing an order for 30 locomotives with the Baldwin Locomotive Works.

The Marine Steel Forgings Company, a French company, has ordered 25 general service cars from the Pressed Steel Car Company.

The Imperial Government Railways of Russia have ordered 6 Decapod type locomotives from the American Locomotive Company.

The Baltimore & Ohio has ordered 1,000 tons of steel from the American Bridge Company for a bridge to be built at Defiance, Ohio.

The Chicago & North Western has ordered 40,000 tons of steel rails from the Illinois Steel Company. The rails are for 1917 delivery.

The Atlantic Coast line has awarded contract for 15,000 tons of rails for delivery in 1917 to the Tennessee Coal, Iron & Railroad Company.

The Pennsylvania Railroad is preparing specifications for a number of Decapod (2-10-0) type locomotives for the Lines East of Pittsburgh.

The Chicago, St. Paul, Minneapolis & Omaha is to install automatic block signals on its line from St. Paul, Minn., to Mankato, 84 miles, single track.

The Pennsylvania Railroad is reported as preparing to place rail contracts for next year's requirements, which will probably aggregate upward of 200,000 tons.

The Chicago Great Western has ordered 10 switching (0-6-0) locomotives from the Baldwin Locomotive Works. This road is reported as contemplating the purchase also of 10 freight locomotives.

The Southern has ordered 1,000 box-cars from the Pressed Steel Car Company and 500 from the Mount Vernon Manufacturing Company, and is inquiring for prices on 1,000 additional ventilated box cars.

The Baltimore & Ohio is reported as awarding contracts for 75,000 tons of rails. The United States Steel Corporation will roll 50,000 tons; Maryland Steel Company, 15,000 tons, and other mills, 10,000 tons.

The Pennsylvania Lines West of Pittsburgh have ordered 25 Mikado (2-8-2) type locomotives from the Lima Locomotive Corporation and is said to have ordered an equal number of the same type from another builder.

The French Government is reported to have placed an order for a large number of additional freight cars with the Canadian Car & Foundry Company. The National Car Company, it is said, will build 2,000 additional steel trench cars for France.

The Montour Railroad has ordered 4 superheater Mikado locomotives from the American Locomotive Company. These locomotives will have 27 by 32-in. cylinders, 57-in. driving wheels, and a total weight in working order of 297,000 pounds.

The Chicago Junction has ordered 5 switching (0-6-0) locomotives from the American Locomotive Company. Cylinders will be 21 by 30 in., driving wheels 51 in. in diameter, and a total weight of engine in working order of 200,000 pounds.

The Denver & Salt Lake has ordered one Mallet (2-6-6-0) type locomotive from the American Locomotive Company. This locomotive will have 21 and 33½ by 32-in. cylinders, 55-in. driving wheels and a total weight in working order of 361,000 pounds.

The Bethlehem Steel Company, South Bethlehem, Pa., has ordered 2 eight-wheel

switching locomotives from the American Locomotive Company. These locomotives will have 22 by 28-in. cylinders, 51-in. driving wheels and a total weight in working order of 196,000 pounds.

The Chicago, Milwaukee & St. Paul has ordered 40,000 tons of rails from the Illinois Steel Company, 5,000 tons from the Lackawanna Steel Company, 2,500 tons from the Pennsylvania Steel Company, and 2,500 tons from the Bethlehem Steel Company.

The New York Central has contracted with the Federal Signal Company for the installation of an electric interlocking plant at Utica, N. Y., with a machine of 180 levers. There will be 143 working levers for the control of 76 signals, 51 switches and 16 check locks. The signals will be Type 4. New York Central standards will govern throughout, including the use of concrete trunking and stakes.

Thirty of the 50 steel passenger coaches and 2,585 of the 4,000 steel hopper cars ordered recently by the Baltimore & Ohio Railroad have been delivered and placed in service, and it is expected that the entire order will be completed within a few weeks, if deliveries continue at the present rate. Besides the car equipment the road has on order 30 Mallet locomotives on which delivery is soon expected, and supplementing these orders contracts have just been let for 50 Mikado freight locomotives and 10 switching engines.

The largest single order ever taken by the Lima Locomotive Corporation was placed on the books last month, when the New York Central System gave this firm a contract for 95 locomotives; 70 of which are to be of the Mikado type, cylinders 25 ins. by 32 ins., weight on drivers 215,000 lbs., weight total 284,000 lbs., boiler straight top type, diameter 80 ins., 7,500-gal. Vanderbilt type tender. The remaining 25 locomotives are switchers, 0-8-0 type, cylinders 25 ins. by 30 ins., weight on drivers and total 239,500 lbs. These are among the heaviest switchers of this type in use in this country. This is the second order of any size taken by the reorganized company, the first one being an order for three large Santa Fe type locomotives for the Erie Railroad.

#### "Movies" on the Baltimore and Ohio.

Moving pictures will be used by the Baltimore & Ohio Railroad as an adjunct to its Safety First campaign, impressing upon employes the importance of being careful in the interest of the personal safety of patrons and themselves. The railroad has purchased a machine for ex-

hibiting motion pictures of railroad operation as performed correctly and incorrectly. The machine will be added to the equipment of the General Safety Committee.

"The House That Jack Built," a scenario written by Mr. Dow, of the New York Central Lines, will be exhibited as a part of the program of the various safety committee meetings which are held by officials and employes monthly. The scenario depicts accurately the life of the railroad employe, showing his early training in transportation service, the requirements of efficiency which must be met before he can be promoted to a responsible position in which he is entrusted with the safety of life and property; also his home life and the contentment in the knowledge that the company is assisting him to purchase a home, educate his children and save a part of his earnings are told on the screen while a warning against evil influences is sounded.

#### Peat Powder Used by Sweden for Locomotives.

Experiments in the use of peat powder on locomotives of the State railways have demonstrated that as heavy trains can be pulled and as good speed be made where this fuel is employed as where anthracite is used, according to a statement issued by the Swedish telegram bureau, which has been received from the secretary of the American Embassy at Stockholm. The statement declares that the powder can technically, as well as economically, take the place of anthracite as fuel for locomotives.

The railway directors have decided to undertake the development of this class of fuel by two different methods for purposes of comparison. Two experts have been requested to give complete estimates of the cost of preparing a certain bog for the manufacture of peat powder, together with estimates of running expenses, by the respective methods. The bog selected is said to be that at Hasthagen, about 1½ miles from the station at Vislanda, with an area of about 500 acres.

#### Economy Is Wealth.

The Chicago Great Western has recently compiled an array of facts, showing what may be accomplished by saving in little things. In the matter of train hauling the saving of a two-cent postage stamp is equal to hauling a ton of freight 3½ miles; lead pencil, 2 miles; track spike, 2 miles; track bolt, 3½ miles; one pound of waste, 10½ miles; white lantern globe, 20 miles; red lamp globe, 75 miles; lamp chimney, 10½ miles; station broom, 35 miles; water pail, 20 miles; track shovel, 90 miles.

Thus do grains of sand make up the vast seashore.

# GOLD Car Heating & Lighting Company

Manufacturers of

ELECTRIC,  
STEAM AND  
HOT WATER  
HEATING  
APPARATUS  
FOR RAILWAY CARS  
VENTILATORS  
FOR PASSENGER  
AND REFRIGER-  
ATOR CARS  
ACETYLENE SYSTEM  
OF CAR LIGHTING

Send for circular of our combination PRESSURE AND VAPOR SYSTEM OF CAR HEATING, which system automatically maintains about the same temperature in the car regardless of the outside weather conditions.

Main Office, Whitehall Building  
17 BATTERY PLACE  
NEW YORK



# Hydraulic

**Riveters Fixed and Portable  
Punches, Shears,  
Presses, Lifts, Cranes  
and Accumulators.**

**Matthews' Fire Hydrants,  
Eddy Valves  
Valve Indicator Posts.**

The Camden High-Pressure Valves.

## Cast Iron Pipe

**R. D. Wood & Company**

Engineers, Iron  
Founders, Machinists.

100 Chestnut St., Philadelphia, Pa.

## Nichols Transfer Tables Turntable Tractors

GEO. P. NICHOLS & BRO.  
1090 Old Colony Bldg. CHICAGO

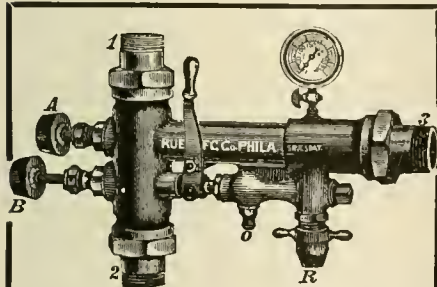

### NOW IS THE TIME to install a Rue Boiler Washer and Tester,

For you will need it when cold weather comes. It will wash out, test and fill your boiler, all with hot water, and have it ready for use in one hour.

THINK IT OVER.  
Catalog on Boiler Washers A-5.  
Catalog on Injectors B-5.

**Rue Manufacturing Co.,**  
228 CHERRY STREET  
Philadelphia, Pa.  
Manufacturers of Injectors, Ejectors,  
Boiler Washers and Testers, Boiler Checks,  
Check Valves.



## ASHTON POP VALVES AND GAGES

The Quality Goods That Last

The Ashton Valve Co.  
271 Franklin Street, Boston, Mass.  
No. 174 Market St., Chicago, Ill

# Books, Bulletins, Catalogues, Etc.

## Coal.

The Technical-Book Publishing Company, Philadelphia, Pa., has published a book on the subject of Coal and Its Economical and Smokeless Combustion, by James F. Cosgrove. The work extends to 280 pages, and is a comprehensive textbook, not only describing every kind of coal and the best methods of combustion but also the types of furnaces best adapted to the burning of coal smokelessly. Many industrial plants use coal that is not well suited to their equipments. Instances are shown where coal bills have been reduced over twenty per cent. when care was taken to select the most suitable kind of coal for the furnace and draft. The work treats fully on the equipment best suited to burn particular kinds of coal, what method of firing is best adapted to the coal and furnace, and what the best method of procedure is for the prevention of smoke. Numerous diagrams illustrate the text. The style of the author is clear and concise and the mastery of his subject complete. A notable feature of the book is the record of a vast number and variety of tests under every conceivable condition, and is a striking proof of the opportunities that the painstaking author has had, and it is rare indeed that a high literary merit is accompanied with such real work, work that is distinctly apart from the mere routine laboratory work, and with which some textbooks are overburdened. One can see at a glance that the author has witnessed these genuine tests in actual service himself, and in this way the book is a sure guide which we recommend with all the uncton that we possess. To railroad men interested in fuel consumption this is an invaluable work. The same might be said of those interested in fuel economy in all kinds of stationary plants, and if the textbook was carefully read and studied by those who should be practically interested in these important matters the saving would be enormous. There is no work of a similar kind that covers the subject so completely. The price is three dollars.

## Rail Joints and Bonds.

"Modern Practice in the Construction and Maintenance of Rail Joints and Bonds in Electric Railways, is the title of Technologic Paper No. 62 just issued by the Bureau of Standards, Department of Commerce. The paper is largely a compilation of information in the nature of data and opinions submitted by forty-two electric railway companies who answered inquiries sent out by the bureau. Loose rail joints are shown to be the most prevalent cause of bond failures, and as a result there appears to be a marked

tendency toward the adoption of improved methods and materials in their construction. The adoption of various types of welded joints to take the place of the common bolted joint appears to be in progress in most of the larger cities. The whole problem of track bonding is shown to be in a state of evolution, owing to new inventions and recent improvements in methods of construction, and as a result complete standardization of these practices cannot be expected for some time to come. Copies of the publication will be sent free to those interested who apply to the Bureau of Standards, Washington, D. C.

## Leakage of Current from Electric Railways.

A study of the problems connected with the leakage of current from electric railways has recently been completed by the Bureau of Standards, Department of Commerce, and the results just published in Technologic Paper No. 63. The theory of the leakage of current from electric railway tracks is developed mathematically, and curves are then plotted to aid in the interpretation of the results. The conclusions to be drawn from the formulas and curves are discussed with special reference to practical problems in electrolysis. It is shown how the escape of electricity from the rails is affected by increasing the track conductivity, as by careful bonding of all joints; by the use of a high resistance roadbed; and by shortening the distance over which a power house or substation furnishes power. The paper is intended primarily for electric railway engineers and others familiar with electrolysis problems. Copies may be obtained free of charge by persons interested upon application to the Bureau of Standards, Washington, D. C.

## Graphite.

In the March issue of *Graphite* there is an article of special interest on the subject of "The Use of Graphite on the Lubrication of Cylinders." Exact data of expenses are furnished regarding graphite lubrication of cylinders showing a saving of 57½ per cent. The data is not furnished by the Dixon Crucible Company from any of their own numerous tests, but from Mr. F. W. Carter, chief engineer of the Wright Wire Co., Palmer, Mass., and is attracting attention in the engineering press. Even with the slightly advanced price of graphite the saving exceeds 52 per cent. At this rate of saving the cost of a device used for feeding dry flake graphite or graphite mixed with oil would be saved in a very short time, and, as is well known, there are a number of

excellent devices already on the market adapted to feed the lubricants. A perusal of the March issue of *Graphite* will be of interest to those interested in economy in lubrication. Copies may be had from the company's main office, Jersey City, N. J.

**Kingsford Boilers.**

Bulletin No. 17, issued by the Kingsford Foundry and Machine Works, Oswego, New York, is of particular interest to all interested in the generation of steam as a motive power. From the data furnished in the interesting bulletin, it is evident that what is known as the Compound Lancashire boiler bears the same relation to approximate perfection in boiler design that the Corliss engine does to engine design, and the reputation already earned by this type of boiler has never been equaled as a factory boiler in European countries. Its adoption has not yet been general in the United States, although it is now used very extensively in some parts of South America, especially in districts where coal is most expensive. It is a fact that many steam users purchase so-called heating surface by the square yard, and consider that they are getting a bargain, whereas real economy lies in the free circulation of the water in the boiler. This is explained very clearly in the bulletin referred to, and the growth of the Kingsford Foundry and Machine Works is the best proof of the growing favor with which their products are being received. The new shop at Kingsford covers 40,000 square feet, and the demand for more space increases. Copies of the Bulletin may be had on application to the company's office at Oswego, N. Y.

**Confidence.**

In the rapid succession of interesting pamphlets issued by the Pennsylvania Railroad Company there are now and then large illuminated posters, the latest being one of unusual attractiveness asking the people to give the management the benefit of their advice. The responses are already said to be very interesting. Most of them, of course, are the reflex of personal grievances. The average traveller looms large in his own eyes. Self preservation is the first law of nature, and self-conceit is the spiked armor that grows on many two-footed specimens of mammals. Many, however, show a helpful spirit on the part of the public. The poster is issued in all seriousness, and it is being met in the same vein. The road is doing its best to give the best service, and the relations between the carriers and the public should be of the most confidential kind. Suggestions that are adopted and prove of value should be published, so that we may all know how the scheme works.

**Bristol Recording Pressure Gauges.**

The Bristol Company, Waterbury, Conn., have issued folder bulletin No.

206, describing and illustrating the company's latest varieties in pressure gauges. Over 40,000 of these gauges are now in use, some of them in continuous service for more than fifteen years. Their unique simplicity of construction is responsible for their durability and accuracy in long continued service, and the degree of perfection of the original design is shown by the fact that 60 per cent. of the total number in use are the same as the original form. A variety of forms, however, are manufactured, and all are fully guaranteed, and are furnished on thirty days' trial, as desired. Sample charts may be had on application.

**Study of Track Bonding Aids Engineers.**

American electrical railway engineers have been provided with a publication on rail joints and bonds which is of special importance to their work, for the double reason that in its compilation use has been made of facts and opinions from half a hundred railway companies, and that a full technical discussion of the subject is presented by the scientists of the United States Bureau of Standards, who have employed the facilities afforded by the Government's laboratory.

Technologic Paper No. 62, as it is designated, is a comprehensive discussion of every phase of the subject, and in its 125 pages, with 29 half-tones and 6 line drawings, it presents a historical and general discussion of bonds and joints, a compilation of information submitted by operating companies, analysis of the facts collected, results of experimental tests conducted by the bureau, and general conclusions.

**A Dangerous Angel.**

In one part of his reminiscences of Locomotive Engine Running, Angus Sinclair says: "I came across a curious steam gauge disorder one day which carried frightful potentialities. A fireman with high art aspirations put a cupid, which he called an "angel," inside the steam gauge. To make the angel stick, he used a paste of thick gum-arabic. When the heat of the rising steam dried the paste, it curled up one leg of the angel like a small horn, and when the pointer of the gauge came round, the leg caught it and held the index fast. Presently a report was made that something was wrong with the "pops" of engine 94 for they went off when the steam gauge showed 60 pounds. Would I have them "screwed down."

"No; we will see what the test gauge says first." The steam gauge was taken down to be tested and the angel's leg was found inviting an overpressure of steam. Angels do not illuminate the inside of our steam gauges any more."

**Locomotive Engine Running and Management**

By ANGUS SINCLAIR

This popular book has been a RELIABLE REFERENCE and comfortable unfailing POCKET EDITION.

PRICE, \$2.00

ANGUS SINCLAIR CO.

114 Liberty St., New York

**STEEL STAMPS**

INSPECTORS HAMMERS

Hand Cut STEEL LETTERS & FIGURES

LATHE TOOLS, TIME CHECKS,

Noble & Westbrook Mfg. Co.

9 ASYLUM ST. HARTFORD, CONN.



**The Armstrong Automatic Drill Drift**

IS DRIFT AND HAMMER COMBINED.



The handle or driver is always ready to strike a blow as the spring automatically throws it back into position.

LEAVES ONE HAND FREE TO SAVE THE TOOL.

Special Circular Mailed on Request.

ARMSTRONG BROS. TOOL COMPANY  
312 N. Francisco Ave., CHICAGO, U. S. A.

NEVER SHRINKS OR DETERIORATES



ESPECIALLY PREPARED FOR THE ENGINEER

WORKS EQUALLY WELL ON HOT AND COLD SURFACES	CLEANS POLISHES and PRESERVES ALL KINDS OF METALS
---	---

GEO. WM. HOFFMAN CO.

Indianapolis

New York Chicago San Francisco

Send for FREE Sample

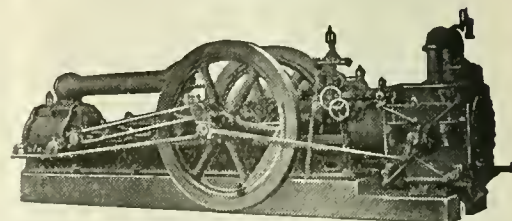

**The Norwalk Iron Works Co.**

SOUTH NORWALK, CONN.

Makers of Air and Gas Compressors

For All Purposes

Send for Catalog

# Railway AND Locomotive Engineering

A Practical Journal of Motive Power, Rolling Stock and Appliances

Vol. XXIX.

114 Liberty Street, New York, May, 1916.

No. 5

## Oroya Railroad in the Andes Mountains in Peru— The Highest Railroad in the World

The frontispiece illustration shows a view of a powerful oil-burning Consolidation locomotive at Ticlio, Peru, with a view of Mount Meigs in the background. Mount Meigs is 18,000 feet above the sea level. The locomotive is shown on the highest point of the Central Railway of Peru, and is 15,865 feet above sea level.

them marvels of construction. There are 16 switchbacks, and the largest copper mines in the world, at Cerro de Pasco, are at an altitude of 12,178 feet. The country is gorgeous with its many lakes and glaciers. The vegetation in the valleys is of the most dazzling brilliance. It is, without exception, not only the highest

also running by gravity the entire distance.

The early locomotives were nearly all of the British type, with inside cylinders. The gauge is standard, 4 ft. 8½ ins., and the equipment generally is excellent, and the railroad rates are a little lower than in the United States. The British engineers and machinists are being replaced

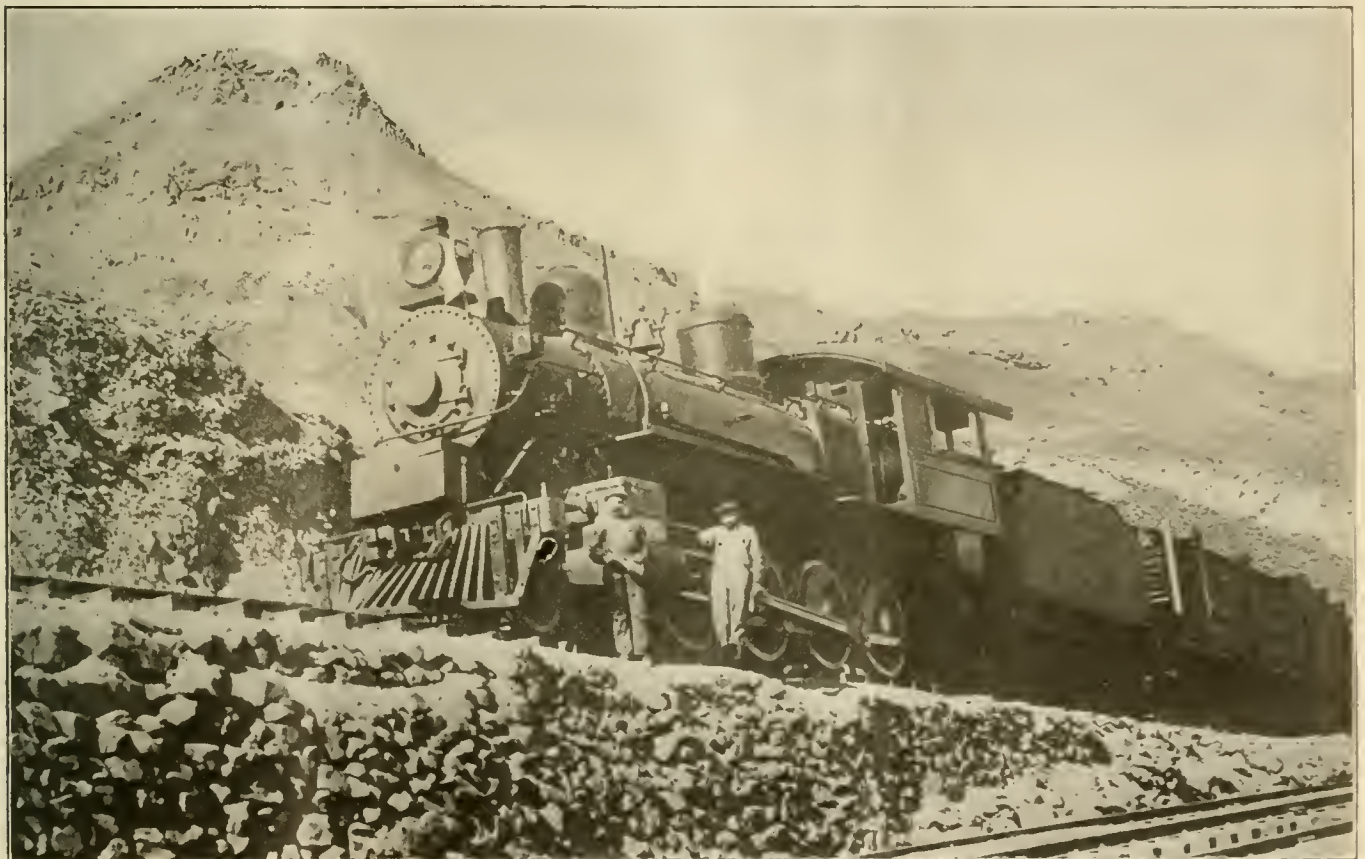

CONSOLIDATION OIL BURNING LOCOMOTIVE AT TICLIO, OROYA RAILROAD.

Copyright by Brown & Dawson and E. M. Newman.

The railroad begins at Huancayo, distant 217 miles, on the Atlantic side of the Andes. The road rises steadily from sea level with an average grade of 4 per cent., much of it through solid rock, to its highest point at Ticlio, which is about 1,000 feet higher than Pike's Peak. There are in all 65 tunnels and 67 bridges, all of

but the most picturesque railroad in the world. It is interesting to note that this extraordinary ascent is made without the use of a single foot of rack line. On the downward journey the passenger trains are piloted by a hand car, equipped, as is the whole of the rolling stock on the railway, with the most powerful brakes, and

occasionally by Americans, and American locomotives are being very favorably spoken of, and bid fair to replace the older British type. The foreign element speak Spanish and the demand for engineering publications in that language is greater than the supply will likely be for some time to come, it is reported.

# Marked Improvements on 2-10-2 Type Locomotives for the New York, Ontario & Western, and the Erie

Important improvements are continuing to appear on the modern high-powered locomotives, and it is interesting to note how admirably they meet the strenuous requirements of the service. Among the more recent and more important new features are ingenious devices for facilitating the curving of heavy motive power, as exemplified in the production of twelve 2-10-2 type locomotives for the New York, Ontario & Western Railway, and

wheel arrangement, with the resulting increased capacity of the locomotive.

	Driving Wheel Base.	Rigid Wheel Base.
N. Y. O. & W.....	20 ft. 0 ins.	15 ft. 0 ins.
Erie .....	22 ft. 6 ins.	16 ft. 6 ins.

These figures for rigid wheel base are well within the figures used on a very large number of Mikado and Consolidation locomotives in service throughout the country.

The lateral box arrangement consists

cross member and the bridge or spacing member above mentioned are interposed two inverted rockers designed so that a lateral force equal to 20 per cent. of the vertical weight transmitted is required to deflect them from their normal position. When the boxes are deflected by a side movement of the first pair of driving wheels from their normal central position, the boxes and the bridge casting are moved laterally in reference to the mem-

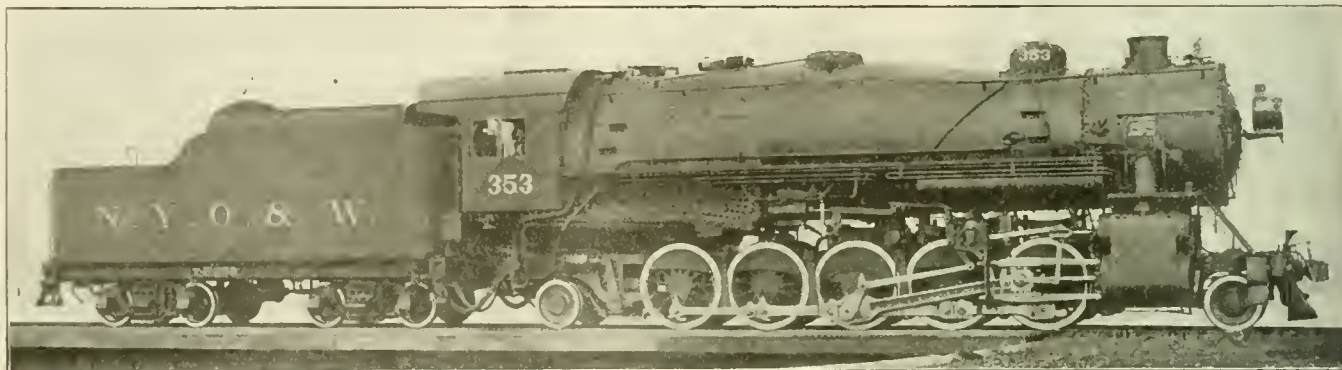

2-10-2 TYPE LOCOMOTIVES FOR THE NEW YORK, ONTARIO & WESTERN RAILWAY.

B. P. Flery, Superintendent of Motive Power.

American Locomotive Company, Builders.

five for the Erie Railroad. These have recently been constructed and delivered by the American Locomotive Company. They are usually known as the mountaineer type, and are in popular favor in mountainous districts, and the examples referred to are attracting much attention among railroad officials.

As train loads outgrow the capacity of the Mikado type, the 2-10-2 type becomes

of two independent driving boxes, whose traverse lateral centers are about on a line with the inside of the main engine frames. These two driving boxes are held in a fixed relation to each other by a bridge or spacing member which engages the inner flanges of the boxes. The weight which is transmitted through this bridge member is applied to the boxes on their transverse centers. The lugs on

ber carrying the springs. This movement deflects the inverted rockers, which offer a definite resistance against the motion. It will be noted that the spring and equalizer work is not shifted from its normal position when the boxes are deflected laterally.

It will be noted from the photograph and drawing that one side of the bridge member is carried down below the driv-

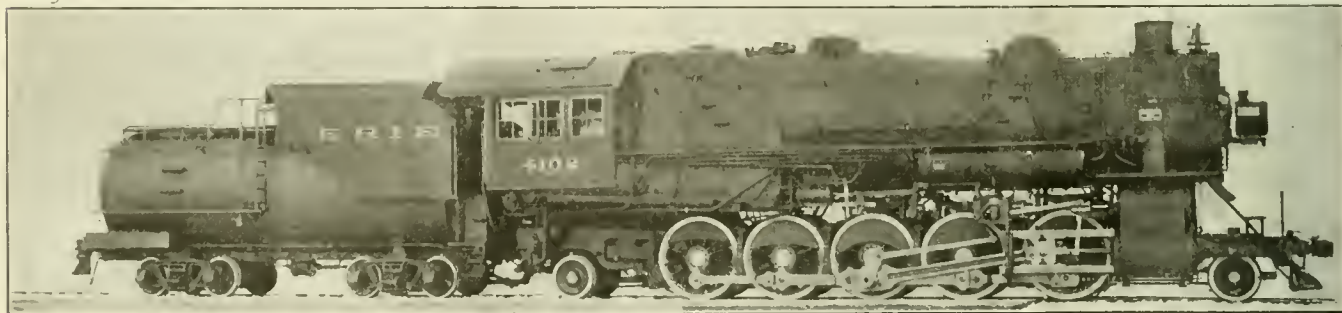

2-10-2 TYPE LOCOMOTIVES FOR THE ERIE RAILROAD.

Wm. Schlafge, Gen. Mech. Superintendent.

American Locomotive Company, Builders.

its logical successor in the same way as the Mikado type succeeded the Consolidation. The 2-10-2 type has formerly been handicapped by its long, rigid wheel base. The application of lateral motion driving axles and boxes to these locomotives was made for the purpose of reducing the rigid wheel base to that which is in common use on locomotives of smaller capacity and at the same time securing the advantages of the 10-coupled

the spacing member which engage the inner flanges of the boxes are for the sole purpose of maintaining the proper spacing of the boxes and do not transfer any vertical load. The driving springs are in about the normal position, and are carried upon a cross member which has a vertical movement only between the engine frames, a wearing shoe being placed upon the inner side of the main frames to prevent side motion. Between this

ing axle with a bolting flange. This is provided for the attachment of a finger to guide the brake beam and insure that the brake heads register properly with tires on No. 1 driver.

The rod connections between the first and second drivers are arranged with a ball knuckle joint ahead of the pin on No. 2 driver, which allows for lateral deflection of the side rods. The construction of the crank pin and rod bearing at

No. 1 driver is clearly shown on drawing. It consists of an ordinary design of cylindrical crank pin, on which is placed a hard, bronze bushing, the interior being bored cylindrical and the outside turned to a spherical surface. Encasing this bushing are two half pieces of hard steel, which are held in place in a rod end with a wedge, in the same manner as two ordinary half brasses. The bushing can revolve either on the crank pin or within the two steel halves. When the rod is deflected from the normal position the spherical bushing allows the parts to rotate sidewise around the center of the front crank pin; at the same time the bushing can revolve on the cylindrical portion of the pin. Several oil holes are provided through the bronze bushing

rear wheel of the truck acting as a driving wheel.

The resistance of the lateral motion box is proportioned with the idea of providing enough initial resistance so that for any ordinary road service on tangent track or road curves the first driver will remain in normal position and deflect only when passing through turnouts and yard curves. The operation of the device in service has clearly demonstrated the correctness of the design in this particular. A close inspection of the engines in operation discloses the fact that the lateral motion first driver very rarely deflects when the engine is upon the road. When the locomotive passes through sharp turnouts or is operating around yards, the lateral motion driver will de-

fect, thus dividing the work of guiding the engine through curves between the truck, first and second drivers instead of truck and first driver only as in the ordinary 10-coupled arrangement. This device has been patented.

This lateral motion driving box can

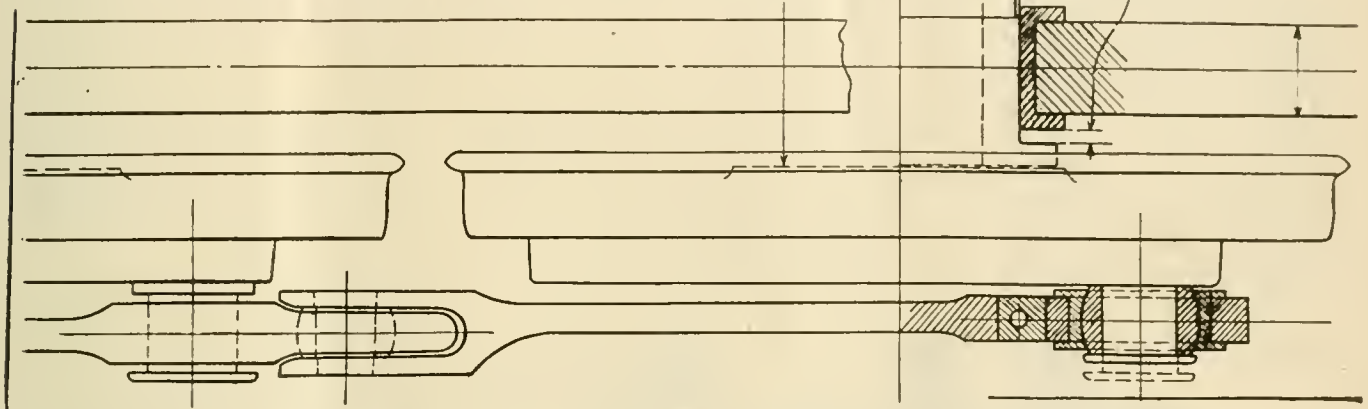

PLAN VIEW SHOWING DETAILS OF CONNECTING RODS AND LATERAL MOVEMENT OF DRIVING BOX.

which insure lubrication of both the spherical and cylindrical surfaces of the bushing.

The operation of the lateral motion axle should be considered in connection with the engine truck. It will be noted that the driving springs of the first and second axles are equalized in the usual manner to the engine truck; therefore, the weight upon the engine truck center pin and the lateral motion boxes on the first axle is divided in proportion to the arms of the front equalizer. The engine truck on this engine is of the inverted rocker type having a resistance of 50 per cent. against the initial movement; and, as stated, the resistance of the lateral device at the first driver is 20 per cent. These resistances are so chosen in relation to the weight coming upon each centering device that the lateral resultants at the engine truck and the first driver are just about the same in amount. It will thus be seen that, in effect, the engine truck and the first driver act in practically the same way as a four-wheel engine truck in guiding the front of the locomotive, except that the lateral resistance is applied in the plane of each wheel instead of being applied midway between the wheels and divided between them, as in the case of a four-wheel truck. As far as guiding the engine is concerned, therefore, the arrangement is very similar to a four-wheel truck application with the

deflect, thus preventing the cramping of the driving wheel base in the curve and excess pressure upon the driving wheel flanges.

It should be noted that the action of the rockers provides a limit to the lateral

also be applied to engines having four wheel trucks.

On the ordinary design of 2-10-2 types, about 80 per cent. of the total weight of engine is on the drivers. It is therefore interesting to note the increase which

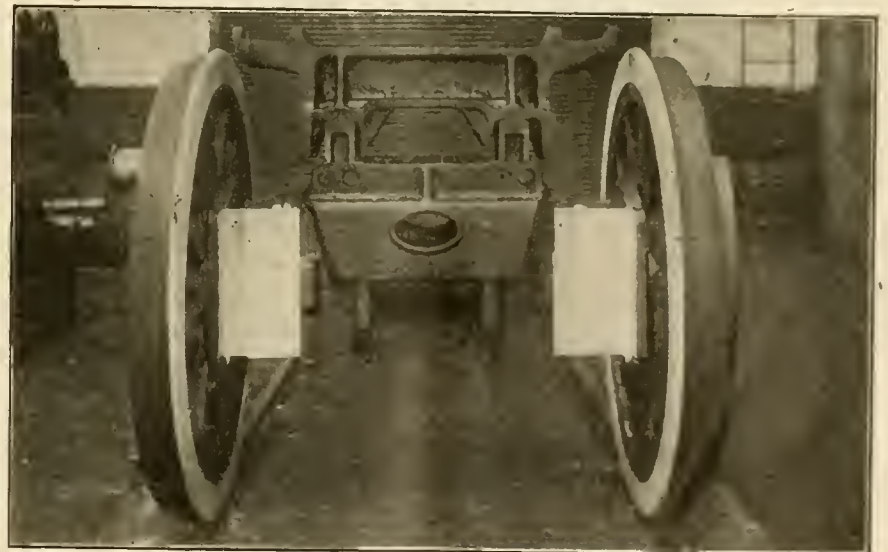

VIEW OF FRONT DRIVER IN NORMAL POSITION.

pressure which can be placed upon the first driving wheel flange. When this lateral resistance exceeds 20 per cent. of the weight carried upon the lateral motion rockers, the boxes will deflect, the excess lateral pressure being then transferred to

has been obtained on these new engines.

	Total Weight.	Weight on Drivers.	Percentage.
N. Y. O. & W....	352,500	293,000	83.2
Erie .....	401,000	335,500	83.7

Most careful attention was given to the boiler design.

	Total Heating Surface, Sq. Ft.	Super-heating Surface, Sq. Ft.	Tube Length, Ft.	Diameter of Boiler at Largest Course, Ins.
N. Y. O. & W.	4,498	1,007	17-0	98
Erie	4,959	1,274	17 0	104

These excellent boilers have the added advantages of a short tube length and a

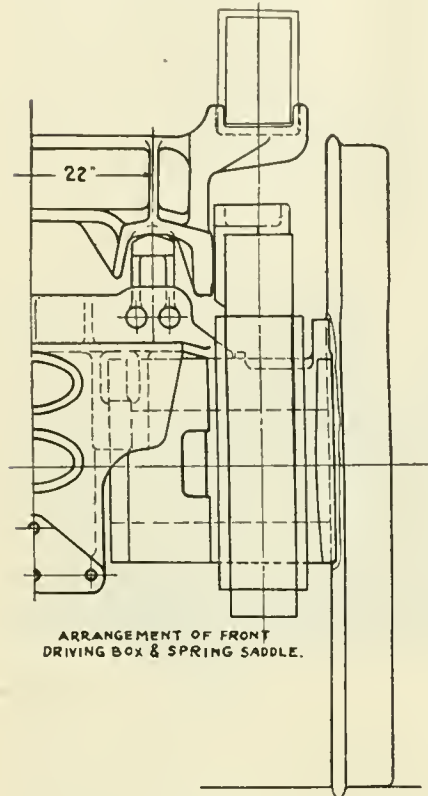

large diameter. A short tube length not only gives greater evaporative value per square foot of heating surface but also reduces back pressure and consequently increases the power of the engine. A large diameter combined with short tube length gives a large volume of water where the evaporative valve is the highest. This large volume of water is ready to flash into steam and therefore increases the reserve supply of steam.

Both these engines have a short distance from the rear wheel to the draw bar. This not only makes the engine ride easier on curves but it reduces the friction between flange of wheel and rail which increases the draw bar pull.

Both engines are equipped with superheaters, a combination Gaines and Security arch, Street stokers, Baker gear, Ragonet air reverse, Chambers throttle, Economy front and rear trucks, and Vanadium frames.

The general dimensions of these engines are as follows:

NEW YORK, ONTARIO AND WESTERN RAILROAD LOCOMOTIVES.

Track gauge, 4 ft. 8½ ins. Fuel, bituminous coal.

Cylinder—Type, piston valve; diam., 28 ins.; stroke, 32 ins.

Tractive power, simple, 71,200 lbs.

Factor of adhesion, simple, 4.21.

Wheel base driving, 20 ft.; rigid, 20 ins.; total, 36 ft. 9 ins.

Wheel base total, engine and tender, 66 ft. 10 ins.

Weight in working order, 352,500 lbs.; on drivers, 298,500 lbs.; on trailers, 24,000 lbs.; on engine truck, 30,000 lbs.; engine and tender, 521,200.

Boiler—Type, extended wagon top; O. D. first ring, 86 ins.; working pressure, 190 lbs.

Firebox—Type, wide; length, 150¼ ins.; width, 96¼ ins.; thickness of crown, ¾ in.; tube ½ in.; sides, ¾ in.; back, ¾ in.; water space, front, 5½ ins.; sides, 5 ins.; back, 5 ins.; depth (top of grate to center of lowest tube), 2¾ ft.

Crown staying, radial.

Flues—Material, cold drawn seamless steel, No. 50.

Thickness tubes, No. 11 B. W. G.; flues, No. 9 B. W. G.

Tube—Length, 17 ft.; spacing, 7/8 in.

Heating Surface—Tubes and flues, 4,173 sq. ft.; firebox, 274 sq. ft.; arch tubes, 51 sq. ft.; total, 4,498 sq. ft.

Superheater Surface, 1,007 sq. ft.

Grate Area, 80.2 sq. ft.

Wheels—Driving diam. outside tire, 57 ins.; center diam., 50 ins.

Wheels—Driving material, main, cast steel; others, cast steel. Engine truck, diam., 33 ins.; kind, rolled steel. Trailing truck, diam., 33 in.; kind, rolled steel; tender truck diam., 33 ins.; kind, rolled steel.

Axles—Driving journals, main, 12 x 22 ins.; other, 10 x 13 ins. Engine truck journals, 6½ x 12 ins. Trailing truck journals, 6½ x 12 ins. Tender truck journals, 6 x 11 ins.

Boxes—Driving, main and others, cast steel.

Brake—Driver, Amer. W. U. 3 and B. C. West. E. T. 6. Tender, West. E. T. 6. Pump, two 11 ins. West.; reservoir, two 20½ x 114 ins.

Engine truck, A. L. Co. Woodard centering device.

Trailing truck, radial constant resistance type.

Exhaust pipe, single; nozzles, six 3/16 in., six 5/16 in., six, 7/16 in.

Grate—Style, rocking.

Street stoker applied.

Piston—Rod diam., 4¾ in.; piston packing, gun iron rings.

Smoke stack—Diam. 21 ins.; top above rail, 15 ft. ½ in.

Tender frame, cast steel.

Tank—Style, water bottom; capacity, 9,000 gallons; capacity fuel, 15 tons.

Valves—Type, piston, 14 ins.; travel, 6¾ ins.; steam lap, 11/16. Line and line. Setting, ¼ in. lead.

In these locomotives the fire box is equipped with the Gaines arch forming combustion chamber at the front of the firebox. The boiler tubes are one-half of Spellerized steel and one-half of hot rolled seamless steel, arranged so that in each

boiler the tubes to the right head of vertical center line of boiler are to be Spellerized steel, and to the left seamless steel.

ERIE RAILROAD LOCOMOTIVES.

Track gauge, 4 ft. 8½ in. Fuel, bituminous coal.

Cylinder—Type, piston valve; diam., 31 ins.; stroke, 32 ins.

Tractive power, simple, 83,000 lbs.

Factor of adhesion, simple, 4.05.

Wheel base—Driving, 22 ft. 6 ins.; rigid, 22 ft. 6 ins.; total, 40 ft. 3 ins. Total engine and tender, 71 ft. 9½ ins.

Weight in working order, 401,000 lbs.; on drivers, 335,500 lbs.; on trailers, 31,500 lbs.; on engine truck, 34,000 lbs.; engine and tender, 585,500 lbs.

Boiler—Type, Ext. Wagon Top. O. D. first ring, 92¼ ins. Working pressure, 200 lbs.

Firebox—Type, wide; length, 160 ins.; width, 108¼ ins. Thickness of crown, ¾ in.; tube, 5/8 in.; sides, ¾ in.; back, ¾ in. Water space, front, 6 ins.; sides, 6 ins.; back, 6 ins. Depth (top of grate to center of lowest tube), 3 ft. 7/8 in.

Crown staying, radial.

Tubes—Material, seamless steel cold drawn No. 317; diam., 2¼ ins.

Flues—Material, seamless steel cold drawn No. 60; diam. 5½ ins.

Thickness tubes, No. 11; flues No. 9.

Tube—Length, 17 ft.; spacing, ¾ in.

Heating Surface—Tubes and flues, 4,617.5 sq. ft.; firebox, 296 sq. ft.; arch tubes, 45.6 sq. ft.; total, 4,959.1 sq. ft.

Superheater Surface—1,274.2 sq. ft.

Grate Area, 94.8 sq. ft.

Wheels—Driving diam. outside tire, 63 ins.; center diam., 56 ins.

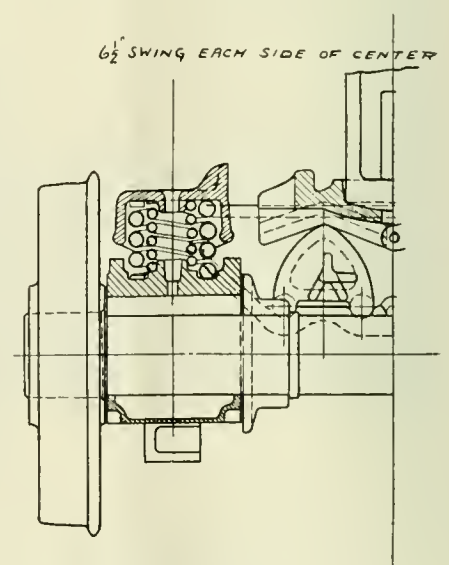

DETAILS OF TRUCK BEARING.

Wheels—Driving material, main, cast steel; others, cast steel. Engine truck, diameter, 33 ins.; kind, forged steel. Trailing truck, diameter, 33 ins.; kind, forged steel. Tender truck, diameter, 33 ins.; kind, cast steel.

Axles—Driving journals, main, 13 x 22 ins.; front, 11 x 19 ins.; other, 11 x 13 ins. Engine truck journals, 6½ x 14 ins. Trailing truck journals, 6½ x 14 ins. Tender track journals, 6 x 11 ins.

Boxes—Driving, main, cast steel; others, cast steel.

Brake—Driver, New York; tender, New York; pump, 2 No. 5; reservoir, two 20½ x 114 ins.

Engine truck, 2-wheel radial swing center. Trailing truck, 2-wheel radial swing center.

Exhaust pipe, single; nozzles, 6¾ ins., 7 ins., and 7⅞ ins.

Grate—Style, rocking.

Piston—Rod diam., 5 ins.; piston packing, snap rings.

Smoke stack—Diam., 23 ins.; top above rail, 16 ft. 37/16 ins.

Tender frame Vanderbilt.

Tank—Style, Vanderbilt; capacity, 10,000 gallons; capacity fuel, 19 tons.

Valves—Type, 16-in. piston; travel, 6½ ins. steam lap, 1 in. Clearance, 1/16 in. Setting, lead 3/16 in.

#### Semaphore for Protection of One-man Cars at Railroad Crossings

Henry L. Doherty & Company, of New York City, is planning to test a new device to assure safety to passengers on its traction systems where one-man cars are in operation. The one serious hazard that still exists in one-man car operation is the crossing of steam railroad tracks. To overcome this the Doherty company has evolved a simple scheme of a track controlled, electrically operated semaphore with active zones on either side of the crossing of steam railroad tracks. The signal normally remains in the "clear" position for the motorman, but when the steam train approaches within a predetermined distance of the crossing, it will automatically turn to "danger" or against the car. Should the electric connections of the semaphore fail it will by gravity go into the danger position for the street car. In some instances, there will be interconnected with the semaphore a derailer to be operated when the signal is thrown into the danger position for the street car, thus derailing the car a sufficient distance from the crossing to prevent an accident.

#### Railways in Finland.

At the beginning of 1914 the total mileage of the Finnish State Railways, including 207 miles of line owned by private capital, but operated by the State lines, was 2,537. Finland has 2,765 miles of navigable waterways, of which, with the present facilities, it is estimated that the freight capacity is about 1,600,000 tons a year. The waterways as well as the railways are under the administration of the State.

## Locomotive Cylinder and Valve Chamber Bushing Boring Bar

Safeguarding all moving parts of machine tools, both stationary and portable, has become not only desirable, but, in many States, obligatory. In the new design of the Rooksby portable boring bar, illustrated herewith, the manufacturers have been guided by the very commendable "Safety First" principle and have carefully guarded all exposed gears and moving parts, sparing no effort to make the machine compact and of ample strength in all parts, yet simple enough to be easily accessible throughout.

These machines are especially designed for reboring locomotive cylinders and valve chamber bushings. They can be used with one or both cylinder heads removed and are easily and quickly set up. The crosshead blocks are bolted to the cylinder with the cylinder head studs and the bar revolves in the sleeves supported and centered by set screws in the crossheads. When

fitting the bar up in valve chamber bushings, a novel device is used enabling the operation to be quickly and accurately performed. This consists of a set of taper cone sleeves in halves, fitting in the counterbore, supporting the bar central while bolting up the blocks and crossheads, after which the cones are removed and the bar is ready for reboring. The sleeves being taper, one set can be used in bushings of various sizes within their range.

These portable boring bars are manufactured by E. J. Rooksby & Co., whose offices and works are at 431-439 North Eleventh street, Philadelphia. Bulletin L, illustrating and describing these tools, will be sent to all interested parties on request. These tools are made in a number of sizes to rebore cylinders of the smallest simple shifting or contractors locomotives to the largest low pressure cylinders on the latest types of compound locomotives,

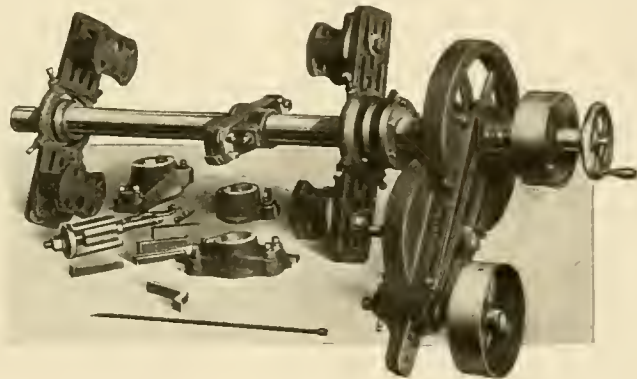

CYLINDER AND VALVE CHAMBER BORING BAR.

boring with only one head removed, the expanding chuck and pin, having five sets of taper gibs to fit the stuffing boxes of various diameters, is used to support the crank end of the bar.

The power is applied to the bar by means of a back gear driving power having a "two-speed quick-change gear drive." This is also a recent improvement of particular advantage where the same bar is used to rebore cylinders and valve chamber bushings of various sizes. The "quick change" is accomplished by simply pulling out a slip pin, shifting the primary pinion out of gear and driving by the intermediate shaft. As the illustration clearly shows, all gears are completely encased.

They have also designed an improved tool holder using high speed cutters for extra hard service. The cutterhead is fed by means of an automatic feed case having two changes of feed controlled by a slip pin. This is also completely encased as shown in the cut. For set-

and all sizes of valve chamber bushings. Mr. Rooksby, president and general manager, has been engaged for many years in designing and manufacturing portable tools for steam engine and railway repair shops; and these, their latest improvements, are but an indication of their aggressive policy of keeping abreast of the times.

#### Farmers and Railway Men.

Farmers are no longer the largest employers of labor in the United States. This position now has been taken by the railroads. In 1910 there were 6,340,357 farms in the United States, which, together with their improvements were valued at \$34,681,507,000, and they paid out for labor that year \$645,612,000. The census report for 1914 shows the railroads of the United States paid out for labor the sum of \$1,373,422,472, or more than twice as much as was paid for all the farm labor in this country.

# Design of Passenger Car Brakes When Braking Ratio Is Not Arbitrarily Chosen

By WALTER V. TURNER, Assistant Manager, Westinghouse Air Brake Co.

In the past issue of this paper I have pointed out the methods consciously or unconsciously followed out in the installation of air brake equipments for passenger cars when the braking ratio is arbitrarily chosen, and at the present time wish to deal with the problem of equipping a car with a brake when either the length of the stop or the rate of retardation is the chief requirement. First it is necessary to ascertain the retarding force necessary to produce the specified stop or retardation; then whether the length of stop desired or the retardation in miles per hour per second specified is physically possible, and to do this it is necessary to determine or assume the capacity of the rail for adhesion. To arrive at this it is necessary to work with the figures given in the specifications, which will be assumed to be a stop from a 60 mile per hour speed in 1,000 feet, and another case in which the specification is a retardation of 3.0 m. p. h. per second from the same rate of speed.

Assuming the weight of the car to be 100,000 pounds, we have all the factors from which to ascertain what the average retarding force must be, namely, a speed of 60 miles per hour, the weight of the vehicle in pounds, and the distance in which the stop is to be made, that is, the retarding force in pounds will equal one-half of the weight of the vehicle divided by 32.2 times the square of the speed in feet per second, divided by the length of the stop in feet. In this case the retarding force will be  $\frac{1}{2} \times (100,000 \div 32.2) \times 88 \times 88 \div 1,000 = 12,000$  pounds.

When the rate of retardation is specified, as assumed as 3.0 m. p. h. per second, the retarding force is ascertained by changing the m. p. h. to feet per second, dividing by 32.2 and multiplying by the weight of the vehicle, that is  $(3 \times 1.466 \div 32.2) \times 100,000 = 13,630$  pounds, the retarding force required to meet these specifications. With the average retarding force now known, the next step is to convert this to the braking ratio required, and to do this we must know the characteristics of the physical equipment to be employed; that is, the coefficient of friction that will be realized, the efficiency of the foundation brake rigging; the maximum cylinder pressure attainable, and the time in which the maximum cylinder pressure is obtained. The combination of these will show the braking ratio required, or rather fix the ratio required.

As to the coefficient of brake shoe friction that we are considering, it will be assumed that the maximum and minimum coefficient realized varies but very little

from the mean or average, and it is permissible to assume this. It has been previously stated that the performance of a brake shoe is extremely variable and that it presents the extreme problem as regards to obtaining uniform retarding force, but before contemplating an estimate of train stop distances, it should be understood that the performance of a shoe depends essentially upon its temperature; its effectiveness increasing with the temperature up to the critical point and then decreasing until the molten point is reached, or until such rapid abrasion takes place as to virtually present a fresh contact surface which prevents the temperature rising further as would otherwise be the case. This temperature in turn depends upon three factors; upon the pressure per square inch of the shoe area in actual contact, the speed at which this area is being traversed by the other contracting factor (the wheel), and the time the rubbing surfaces (shoe and wheel) are in contact. If this be true, then the performance of the brake shoe is likewise affected by the three factors mentioned, not directly, but indirectly by the heat generated. All of these factors are actually present in any train stop, but since some of them may be working in one direction and some of them in another, the actual effect may be a constant as far as the coefficient of friction is concerned. As an example, the effect of time, unless neutralized, is to lower the coefficient of friction; the effect of speed, unless neutralized, is to increase the coefficient of friction; obviously then the net result may be an increasing, a decreasing, or a constant coefficient of friction throughout the stop, or all of these may occur at different times during a stop. It should also be understood that a combination of factors may apparently contradict the presence of any or all that have produced the observed result; for instance, if the seven colors of the spectrum are mixed together, white will result, which on the face of it contradicts the presence of red, or any of the other colors, but they are there nevertheless, and the person dealing with the subject of colors takes this into consideration just as the man who expects to employ his talents in brake design must have in mind all the phenomena involved in train braking.

Naturally it is the quantity of the work done that determines the efficiency of the brake shoe, and some years ago I was forced to the conclusion that the laws of friction as expounded in the old text books, for instance, that friction is independent of pressure and bearing surface,

or things of that sort, as I had attempted to interpret them, were all false when applied to modern brake shoe performance, but that on the contrary, friction, time, pressure and speed have a vast influence upon the friction or performance of the shoe, and in an effort to secure something tangible for a base of investigation, I employed methods of exclusion and elimination, or of extremes. That action and reaction are equal and in opposite directions and that extremes meet we all know, and since we know that the coefficient varied for a brake shoe, I attempted to find the point at which it reached a maximum, therefore the assumption that if a shoe is infinitely cold, down to absolute zero, that shoe will have very little friction, negligible as far as train stops are concerned, and if it were infinitely hot, which would be a gas, it would have little or no friction. Without going to the extreme of gas, if the shoe is molten it will have no friction, and since it has none when at its coldest and none when at its hottest, there is some point between these two where the friction is at the maximum, and in an effort to locate this point I reduced all of these influences upon friction, such as pressure, speed and time, to the one term of heat and concluded that heat is the sole cause of the variation in the coefficient of friction.

I knew to start with that the maximum could not be at an atmospheric temperature, because the coefficient of friction rises with any type of brake shoe when it is first applied to the wheel, but by the use of instruments such as the cronograph and electric thermometers and by removing portions of car floors, it was found that the maximum coefficient of friction was attained when the temperature of the shoe was about 800 degrees and when this temperature was reached the coefficient would fall and continue to fall until it would become negligible if the molten metal could be confined. However, when the metal was nearing the molten point, the abrasion would set up and present a new surface and through this action the coefficient remained practically constant, or the coefficient of friction at the beginning raised from 15 per cent. as high as 18 or 20, then dropped to approximately 10 per cent. and remained there during the stop. It will be understood that the point at which the highest temperature is reached depends upon a variety of conditions, but with modern brake shoe pressures, we are not concerned with the minimum coefficient of friction because at low speeds we do not reach it before the stop is made and at high



speeds we go beyond, and from an average we have presumed that 10 per cent. was what could be safely employed in stopping a train and that 10 per cent. was all that could be obtained, that is, the average coefficient of friction realized throughout a train stop is approximately 10 per cent.

From such considerations, namely, time, cylinder pressure, efficiency of brake rigging, performance of brake shoe, it follows that the nominal braking ratio of the installation has no fixed bearing upon the retarding force realized when it comes to stopping a train, that is to say, it gives no direct or conclusive information as to the length of the stop. To revert to the problem under consideration, if we have a coefficient of friction of 10

per cent. and a 90 per cent. efficiency of foundation brake gear, a maximum cylinder pressure of 100 pounds, and a retarding force required of 12,000 pounds. For the first case, the braking ratio will then be  $12,000 \div (.10 \times .90 \times 100,000) = 133$  per cent.

This is without taking into consideration the time required to get the brake fully applied, which will be assumed as two seconds, or from the averages, that the brake is fully for one-half of the time or one second, or the train runs for one second, or 88 feet, without the brake applied, therefore the stop must actually be made in 912 feet, which will require an average retarding force of  $(\frac{1}{2} \times 100,000 \div 32.2) \times 88 \times 88 \div 912 = 13,140$  pounds.

Therefore the actual braking ratio necessary is  $13,140 \div (.10 \times .90 \times 100,000) = 146$  per cent.

The next step is to satisfy ourselves that this braking ratio is possible of employment without the likelihood of wheel sliding, and to do this it is necessary to know whether or not the brake shoe pull required will exceed the rail pull on the wheel.

Since we know that from 20 to 25 per cent. of the weight of the vehicle on the rail can be realized in rail pull, or adhesion, it is clear that we are entirely within the limit since the brake shoe pull will be  $1.46 \times .90 \times .10 = 13$  per cent. of the weight of the vehicle, while the potential of the rail is 20 per cent. of the weight of the vehicle.

## The Merit of Graphite as a Lubricant

By H. BURNSIDE, Meadville, Pa.

I noted with considerable interest the question and answer on "Graphite" appearing in the Department of Questions and Answers in the April issue of RAILWAY AND LOCOMOTIVE ENGINEERING, and I would like to add some additional facts that are different in some degree from the able answer furnished.

In the first place it may be said that very little is known of the physical and chemical elements which go to make graphite so efficient when used as a lubricant and in fact when speaking of it as a lubricant we are as much in error as if we called "soap stone" a lubricant also. The actual benefit of using graphite is not for lubrication, but to prevent heating by friction, for the application of graphite in its natural form on a hot bearing will be of no benefit, while with a liberal use of a good oil the bearing will soon cool down and give satisfactory service.

Graphite is one of the pure forms of carbon, which is one of the seventy or eighty primary elements out of which all material is formed. As an example of the mysteries of just what graphite really is, it must be remembered that carbon only occurs pure in two different and contrasted forms—the diamond and graphite. If each of these substances was a compound or mixture of different elements, comprising carbon in both cases as the principal constituent, there would be no cause for mystification, but they are absolutely the same unmixed thing, although totally unlike in appearance and properties. The molecules of each are the same—being molecules of carbon and nothing else—but in one the molecules are so arranged that they form a transparent, excessively hard crystal endowed with marvelous powers of reflecting light which make it the most dazzling of all gems, and in the other the same molecules are so arranged that they form a dull, soft, black or gray substance which

leaves a dirty mark when rubbed on a white paper. As a proof of this, burn a diamond and it turns to graphite.

The real action of graphite when used for lubricating purposes is very easy to understand when we remember that it is impossible to machine two metal-bearing surfaces absolutely smooth, and if placed under a microscope the two surfaces which are apparently smooth to the touch are in reality made up of very irregular surfaces similar to mountains and valleys, and when these surfaces are rubbed together the entire weight is not supported by the entire surface, but only rests on the high spots or "peaks" of the irregular surfaces. Much friction is generated from the fact that the total weight is supported on too small a bearing—the "peaks"—and will become heated till worn down. The application of graphite, which is a material not affected by heat, cold or pressure, fills in all the low spots or "valleys," building them up to an equal height with the rest of the high spots, and as this material is frictionless it helps to support the weight and take off the load from the high spots. To prove this idea, take some given weight and support it on two different bearings where one bearing is only half the surface of the other, and notice which bearing will become hot first.

We often hear it said that the application of graphite has formed a "coating or glaze" on some particular surface which is only half of the real facts, for the graphite has not formed a complete glaze, but has filled in all the low spots to an equal height with the high spots of the metal, so to the touch it appears like a "glaze," being so smooth.

The reason why graphite is more efficient when fed with oil is on account of the oil carrying it to all points better than when applied in powder form. Also with the application of oil it must be remembered that the oil tends to separate the

two surfaces very slightly, which permits the graphite to get in between them and be moved along till it reaches a pocket into which it is forced by weight. Graphite is very light, and if used in dry powder form it is blown along with the many currents formed in a cylinder by the action of the piston and will, as a rule, only reach the same point where it will tend to build up and form carbon. There are many theories on how lubricating oil acts when it is admitted into a cylinder, one of which is that the oil immediately flies to the walls, and if this is correct the reason why graphite is better when used with a low grade oil is obvious.

It must be remembered that true efficiency of graphite application must be regular and of a steady amount; for, if fed in a cylinder at irregular intervals and in irregular amounts, there can be only so much taken up at each stroke of the piston, and the balance will be wasted or else built up in the form of carbon.

The reason why less oil is required when used in connection with graphite is that there is less weight on the high or bearing points, which in turn makes less friction on these points, thus requiring less oil to maintain perfect lubrication.

An exaggerated comparison of how graphite acts on two bearing surfaces is to take two hand saws and try to rub the teeth edges together, these edges comparing with the rough surfaces of two bearing metals, and see how hard it is; also note the actual amount of bearing surface the tops of the teeth afford. Now, if it were possible to fill in all the teeth with graphite till a smooth edge was secured and then rub the two edges together, it would be noted how much less the friction was, and besides, on the same length and width saw, there would be much more actual bearing surface and consequently much less friction.

# Relation of Grades to the Efficiency of Locomotives

By W. McD. TAIT, Pincher Creek, Alberta, Canada

In the C. N. R. classification of engines, one per cent. means one thousand pounds of tractive effort (or pull). The engine hauling the Transcontinental Special is thirty-five per cent. It is, accordingly, capable of a "pull" of 35,000 pounds. The train itself, of 15 cars, is 1,235 feet in length, and weighs 1,200 tons, inclusive of the engine, which weighs 165 tons loaded. From Edmonton westbound, a thirty-five per cent. engine would haul 32 loaded freight cars of an average weight, car and contents, of 50 tons each, over the five-tenths of one per cent. maximum railway grade between Edmonton and the Pacific Coast, the train running towards the coast. The same engine would be able to pick up thirty-three other loaded cars of similar weight at the Albretha Summit and carry the total load of 65 cars to the coast. A 50 per cent. engine, C. N. R. classification would haul 65 loaded cars to the Albretha Summit and 90 to the coast.

A 35 per cent. engine starting out from the Pacific Coast towards Edmonton will handle 35 loaded cars, or a total of 1,750 tons as far as Blue River (383.3 miles from New Westminster Bridge). Between Lucerne and Blue River—a distance of 110 miles—the maximum gradient of the C. N. R. in the Rocky Mountains—seven-tenths of one per cent.—occurs. In that division a 35 per cent. loco-

motive will handle 24 loaded cars or 1,200 tons. From Lucerne to Edmonton, the same locomotive would pull 36 loaded cars, or 1,800 tons. The hauling capacity of a 50 per cent. engine would, of course, be proportionately greater.

Now as to passenger traffic. Taking as a basis a transcontinental train of eight passenger cars, a 35 per cent. C. N. R. engine could run through to the Coast, westbound between Edmonton and Vancouver, at a minimum speed of 40 miles an hour, and the speed would drop to that rate only on the section of line affected by the five-tenths of one per cent. maximum grade. Eastbound, on the division where the seven-tenths of one per cent. maximum gradient occurs, or the 110 miles between Blue River and Lucerne, a 35 per cent. locomotive would be able to haul the eight-car train at a speed of 30 miles an hour. Apart from that division a speed could be obtained as great as desired up to 50 miles an hour between Vancouver and Edmonton.

Broadly speaking, the addition of each one-tenth of one per cent. in the grade of a railway means that the efficiency of the engine is reduced two pounds for each gross ton of its load. The frictional resistance of equipment moving over a level track has been arbitrarily fixed at five pounds per gross ton. As the line rises, two pounds for each one-tenth of one per

cent. of grade are added to the five pounds per ton. To interpret; a grade of four-tenths of one per cent. would mean a frictional resistance of 13 pounds for each gross ton of the load; the five pounds arbitrarily fixed and the eight pounds for the four-tenths of one per cent. of grade; *i. e.* the total for a five-tenths of one per cent. grade would be 15 pounds; that for a six-tenths grade 17 pounds; that for a seven-tenths grade would be 19 pounds; and for a one per cent. grade 25 pounds. To ascertain the tonnage possible for a locomotive to handle on any grade up to one per cent., the calculator would be quite within the bounds of reason to subtract 10 per cent. from the total hauling capacity of the engine and to divide the remainder by the frictional resistance as given above. To give an example of a 35 per cent. engine:

Total tractive effort..... 35,000  
Less 10 per cent..... 3,500

Working power ..... 31,500

Divide this by 13—the frictional resistance on a four-tenths per cent. grade per gross ton—and the result will be 2423 gross tons, as the total possible gross load for that locomotive. Subtract the weight of the engine and tender and the load will be 2,258 tons, which at 50 tons each for a freight car and contents gives 45 cars.

## Improved Rod Grease Cup.

By JAMES A. KEEGAN, CINCINNATI, OHIO.

The accompanying sketch shows the details of a grease cup constructed by Mr. J. Henry in shops of the Big Four, and applied to the main and connecting rods of locomotive No. 6943, running between Cincinnati and Springfield, a distance of 80 miles, and making the double journey each day. The engineer, Mr. William Hanrahan, states that he has run the engine 1,600 miles with one filling of the grease cup with the regular pin grease, which is a remarkable record, and no appearance of heating of the bearings at any time. The cups are applied to the back end of both main rods, and back end of both side rods.

The cup as shown is made with a piston and compressed with a spring. It is very simple and after being filled with grease takes care of itself. The cap of the cup has two dowel pins pressed down in two grooves and turned to make the cup tight, the purpose of the dowel pins being to keep the piston from turning. As there has been considerable trouble with heated pins this contrivance evidently has solved the difficulty. It is easy of construction and efficient in service.

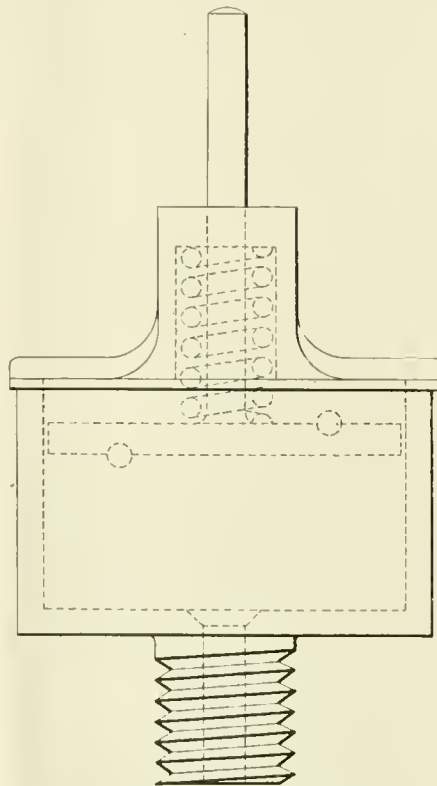

IMPROVED ROD GREASE CUP.

## Etching Machinist's Tools.

By R. S. BOOTH, HICKORY, N. C.

All machinists have tools that they would like to mark their name or initials on but do not do so, on account of the ordinary stencil affecting the accuracy of the tool and for other good reasons.

A good way to mark any kind of a metal tool without affecting it in any way is by the use of "Bluestone." Smear a film of wax over the spot to be marked, about one-sixteenth of an inch thick, take a pencil and write in the wax the designating marks you wish to use and then fill these marks with a solution made by dissolving equal parts of table salt and Bluestone in water. Let the solution stand in the grooves or letters from one to three minutes until it has eaten into the metal sufficiently deep, and you will have a good, clean cut, permanent mark.

## Liners, Their Use and Abuse.

By A. D. Carl, Salamanca, N. Y.

One of the most important things in the roundhouse, as I see it, is liners of the proper size and thickness to meet every need for which liners are used, and to have them ready when they are needed. And there is no reason why we could not

have them and thereby save time and material if the scrap pieces from the shears were used for this purpose, instead of going to the scrap car. There should be liners in the store room of the proper size and thickness to meet every need.

One of the sights of the roundhouse is to see five or six men putting a 5-16 plate under the shears to cut a piece to make a 2½ by 4-in. liner that could have been cut from a scrap piece by one man the day before. But there are results of a more serious nature than this; the man who is in a hurry doesn't always cut a liner of the proper size or thickness.

If he needs a ¼-in. liner and it is not at hand, he will take two pieces of ⅝ in. or four pieces of 1-16 in., or he may find a piece of ¼ in. which is a trifle small and use that. Consequently, he puts up a job unfit to go out of the house.

If we put in two liners where one should do, we double the chance for a pound, and the thinner the liners the more useless they are. It is the solid liner of the proper size that counts. Can you imagine a machinist taking down a driving box wedge with a 3-16-in. liner on it and put on another ⅝ in. and a 1-16 in. because he did not have a 3/16 in. convenient or there was no material to cut one from? But they do it, and results speak for themselves. You have doubled the number of liners, also doubled chances for pounds and wear. Oh, you sloppy wedges on account of poor liners.

Do engineers complain of not being able to keep the front ends keyed up? If they do, you should remove the collar and see how many liners there are between the block and wedge. Or there may be several between the brass and block, but the result is the same. During my experience I have taken out as many as 14 liners from a front end of main rod between block and wedge. They were put there by the fellow who is always in a hurry and who always puts in a 1-16 in.

It appears to me as if we could make a nice saving by cutting up the scraps from the shears, which are sold for ten or twelve dollars per ton, and save the new sheets, for which we pay so much more, and we also will save the foundation of our engines, *i. e.*, the driving boxes and rods.

### The Eight Hour Day.

BY M. H. GRAY, SAVANNAH, GA.

The press every day makes statements about the demand of an eight-hour day and time and a half overtime after the expiration of eight hours. As an engineer who has been some time in the business, I cannot see why brakemen, or trainmen, who have practically little to do, and we have to stop a forty-five or fifty-car train dead still for them to get up. They ride in the caboose all the way. They may occasionally have to put in a brass or an air hose on.

I have always been a believer in justice. I should thank Federal authorities for a law to that effect that all cases should have to be arbitrated before a strike. The railroads sell transportation, the public should be heard, who buys transportation. If I say these matters where the public is concerned will be taken to the ballot, and as is very well known that the railroad man, the transportation fellow hasn't got a vote. He never registers. I heard a politician get up, make this statement when he got in office, and if the public is going to pay for it they are going to force it to the ballot.

A gentleman very high up reaches people I can never reach. He said to me: "I always thought the engineers were fair, square minded people, always willing to arbitrate their troubles and attended to their own business without bringing others into it. He says they are an awful dissatisfied kind of people." I said to him, "Colonel, there are some questions that need looking into." I said: "In our case there are a lot of hardships that could be prevented. The Federal hours of law, sixteen hours, are very long. Now the other day an engineer said, 'I am on a dead drag, almost reached the destination. I get orders to side track the train, back up forty miles, where a derailment had occurred.' He got soaking wet in the heaviest kind of rainstorm. When he got back to his train he was tied up under the Federal service hours. Cold! Wet! Only ten miles away from where he could have gotten a good bed. Then he thinks you are rubbing it in. I think we could get some better conditions."

But the train now is entirely controlled by the engineer; all air. So the gentleman said. Why this grand consolidation of labor, big trust company, and I don't think it will work in all cases, believing everybody being heard, and it is carried to the ballot, if the public is going to pay for it they will defeat it. I would like to see some better conditions in some places I have been, a better place to wash up in, a better riding engine, without making a demand for a whole lot of people that haven't got anything to do. He is not responsible for the train. The engineer and fireman have the work to do. So let the public be heard in the matter; let the matter be arbitrated; let each portion of labor be separate, and the paper states it will not be arbitrated and threatens with a strike.

### Peat Powder as Locomotive Fuel

Experiments in the use of peat powder on locomotives of the State railways have demonstrated that as heavy trains can be pulled and as good speed be made where this fuel is employed as where anthracite is used, according to a statement issued by the Swedish telegram bureau, which has been received from the secretary of the American Embassy at Stockholm.

The statement declares that the powder can technically, as well as economically, take the place of anthracite as fuel for locomotives.

The railway directors have decided to undertake the development of this class of fuel by two different methods for purposes of comparison. Two experts have been requested to give complete estimates of the cost of preparing a certain bog for the manufacture of peat powder, together with estimates of running expenses, by the respective methods. The bog selected is said to be that at Hesthagen, about 1½ miles from the station at Vislanda, with an area of about 500 acres.

### Origin of Coal.

Information as to how coal was originally formed will not enable an engineer to make his engine pull a car extra, but it is likely to prove of interest to anyone who reflects on how the carbon of coal is transformed into mechanical energy.

An eminent French engineer having charge of the coal mines at Commentry, who has given the formation of the coal beds exhaustive study; says that the mines mentioned were formed by vegetable matter carried from long distances, laid down in horizontal layers, one above the other. The theory is advanced that the climate of the coal-forming epoch having been extremely moist, abundant floods carried away whole forests and swept them into lake basins, the trees forming great rafts of logs which constituted the coal measures. The heaviest materials—gravel, sand, clays and other substances were deposited in the order of their density, the lighter vegetable matter floated longer and being deposited last. This, it is thought, explains why the layers of earth and coal are not parallel, and why all the layers in deltas are inclined in the same direction and at different angles.

### "Luck."

One of the many ways in which the individual unwisely eclipses himself is in his worship of the fetish of luck. He feels that all others are lucky, and that whatever he attempts, fails. . . . Their "luck" was that they had prepared themselves to be equal to their opportunity when it came and were awake to recognize it and receive it.

### Telegraph School

A station school for instruction in telegraphy has been started in San Francisco under the management of the Southern Pacific. Mr. I. I. Miller, formerly agent at Red Bluff, Cal., is instructor. Half of the time is spent in the classroom, and the remainder of the time in actual station work. The students, of which there are 20 enrolled, are paid full time.

# Important Improvements in Superheater Appliances Relative Values of Saturated and Superheated Steam

A mistaken idea is prevalent that the use of highly superheated steam was perfected on European railways, but the facts are that its use had been repeatedly experimented with, both in Europe and America for many years, and while its partially successful application was largely due to the efforts of Dr. Wilhelm Schmidt and others, who succeeded in establishing some degree of economy in locomotive practice, it was not at first considered possible to generate steam

order that the large class of studious men engaged in the mechanical department of railways should keep informed of the superheating appliances up to the present hour. In this regard it may not be generally known that for every 100 pounds of common or saturated steam delivered to the cylinder only 65 pounds are available in performing work. This loss can be overcome by the use of highly superheated steam, and, as shown in Fig. 1, the saving is very limited in a low or mod-

boiler and at the same time producing an equivalent power output, the effect of preserving a supply of steam is produced thereby, increasing the boiler capacity, which makes possible the running of the locomotive at longer cut-offs at higher speeds, which greatly increases the hauling capacity. In addition to these advantages, experience has shown that the maintenance of engines equipped with the improved superheating appliances costs little more than similar engines perform-

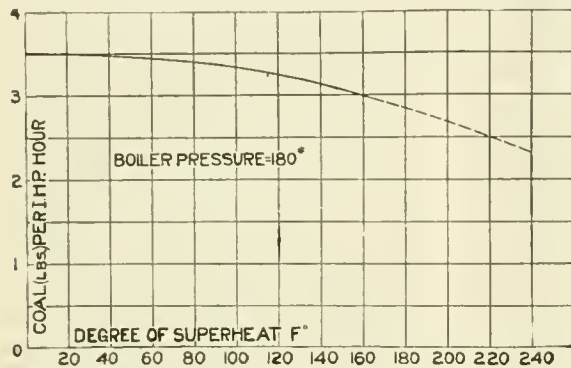

FIG. 1.—COAL SAVING FOR INCREASING DEGREES OF SUPERHEAT.

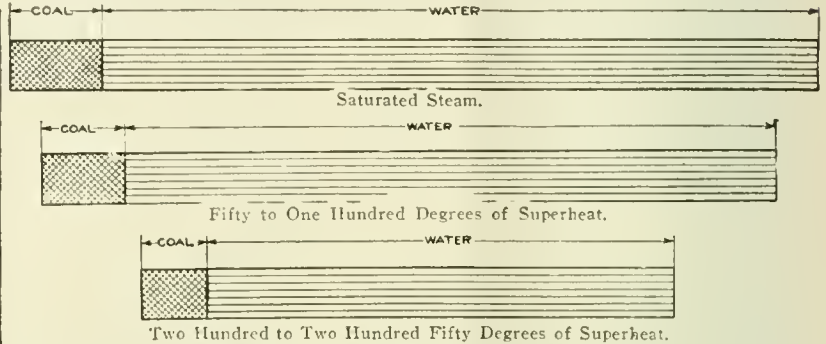

FIG. 2.—COMPARISON OF COAL AND WATER CONSUMPTION OF SATURATED AND SUPERHEATED STEAM LOCOMOTIVES OF THE SAME TRACTIVE POWER.

at high temperatures within the limited fire space of a locomotive. Superheater appliances in the smokebox, while producing some advantage, were beset with difficulties by obstructing the front end, and the cost of maintenance almost offset the limited advantage. Its success was not particularly marked on the locomotive until it was taken up by American engineers, and the result is that to-day there are over 35,000 locomotives equipped with the device, and a universal increase in power with little or no increase of cost,

erate degree of superheat, but increases rapidly as the superheat is increased. The dotted portion of the line shows the degree of rapidity of this increase of saving. Repeated tests have clearly shown that by forcing a saturated steam engine its efficiency is decreased; whereas, if a superheated steam locomotive is forced its efficiency is increased. Neither steam nor coal consumption is materially affected by considerable changes in boiler pressure, so that the use of lower boiler pressures and larger cylinders is justified in con-

ing the same work while using saturated steam. A superheated engine can use steam at a lower pressure and requires the evaporation of less water to handle a given tonnage, thereby making a large reduction in boiler maintenance, and, as we have already stated, prolonging the life of the boiler. Not only so, but the cost of equipping a locomotive with a superheater will be covered by the saving in coal and water during the first year, and where engines have been worked to their full capacity as much as twice the original

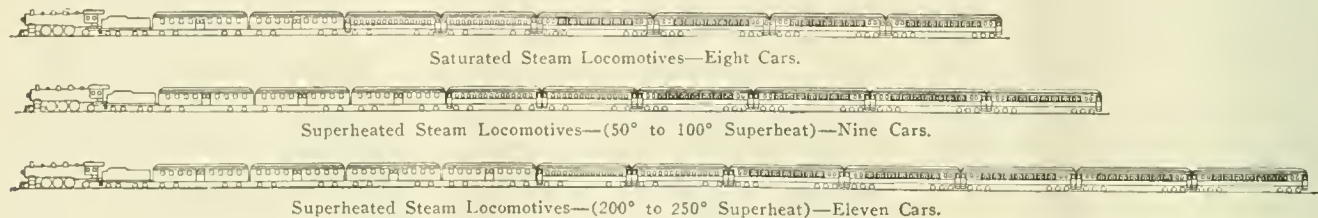

FIG. 3.—COMPARISON OF THE HAULING POWER AT IDENTICAL SCHEDULES OF SATURATED AND SUPERHEATED STEAM LOCOMOTIVES OF THE SAME WEIGHT USING THE SAME AMOUNT OF COAL PER TRAIN MILE.

the gain ranging from 25 to 35 per cent., so that the use of superheated steam is, as developed in the atmosphere of American enterprise, unquestionably the most important improvement that has ever been made on the locomotive.

Its use is now so familiar to American railway men that little explanation of its advantages is necessary, but as the marked improvements made by the Locomotive Superheater Company are so important that we deem it proper they should be referred to at some length, in

nection with superheat, thereby extending the working life of the boiler.

Fig. 2 illustrates the amount of coal and water consumed in saturated steam locomotives and moderately superheated steam, and also when highly superheated steam is used; while Fig. 3 shows the hauling capacity with the same amount of coal. It should be borne in mind that these comparisons are made from engines developing the same tractive power. Thus it will be seen that by reducing the rate at which the engine draws steam from the

cost of the superheater appliance has been saved in the first year's service.

Coming to the details of the improved form of superheater as furnished by the Locomotive Superheater Company, Fig. 4 shows detailed views of the appliance. It will be noted by observing the arrow-points that the steam, after passing from the dome along the dry pipe enters a header supported on brackets in the smokebox, and making a joint with the steam pipe in the same manner as the tee head in locomotives using saturated

steam, with this variation that the header is divided into compartments. In the bottom or lower face of this compartment header there is a series of openings with means to form joints with coils or units of pipes. Each union leads to a coil of four pipes, each being about 1½ ins. in diameter. To accommodate these four pipes there are a series of enlarged flues about 5½ ins. in diameter, and by following the arrow-points it will be noted that the steam is led by the smaller pipes along the interior of the larger flue to a distance of about 2 ft. from the back flue

variations in temperature in the receptacles for the saturated steam and those for the superheated steam induced fractures in the castings. This has now been entirely obviated by variations in the structural walls, so that the necessary degree of flexibility is obtained sufficient to avoid any tendency to fracture.

The joints of the pipe coils to the lower face of the header are held in place by bolts, the heads of which are shown on the upper face of the header, the lower end of the bolt being threaded and furnished with adjustable nuts.

pipes conveying the steam from the dry pipe to the branch steam pipes the temperature of the steam is increased by its near contact with the heated gases finding their way through the enlarged flues, and reaches the cylinders at a temperature as high as 650 degrees Fah., while the temperature on the dome may rarely exceed 388 degrees.

As may be readily imagined when a locomotive is running with the throttle closed and no steam passing through the coiled pipes, although the fire at such times is not projecting heated air or gases

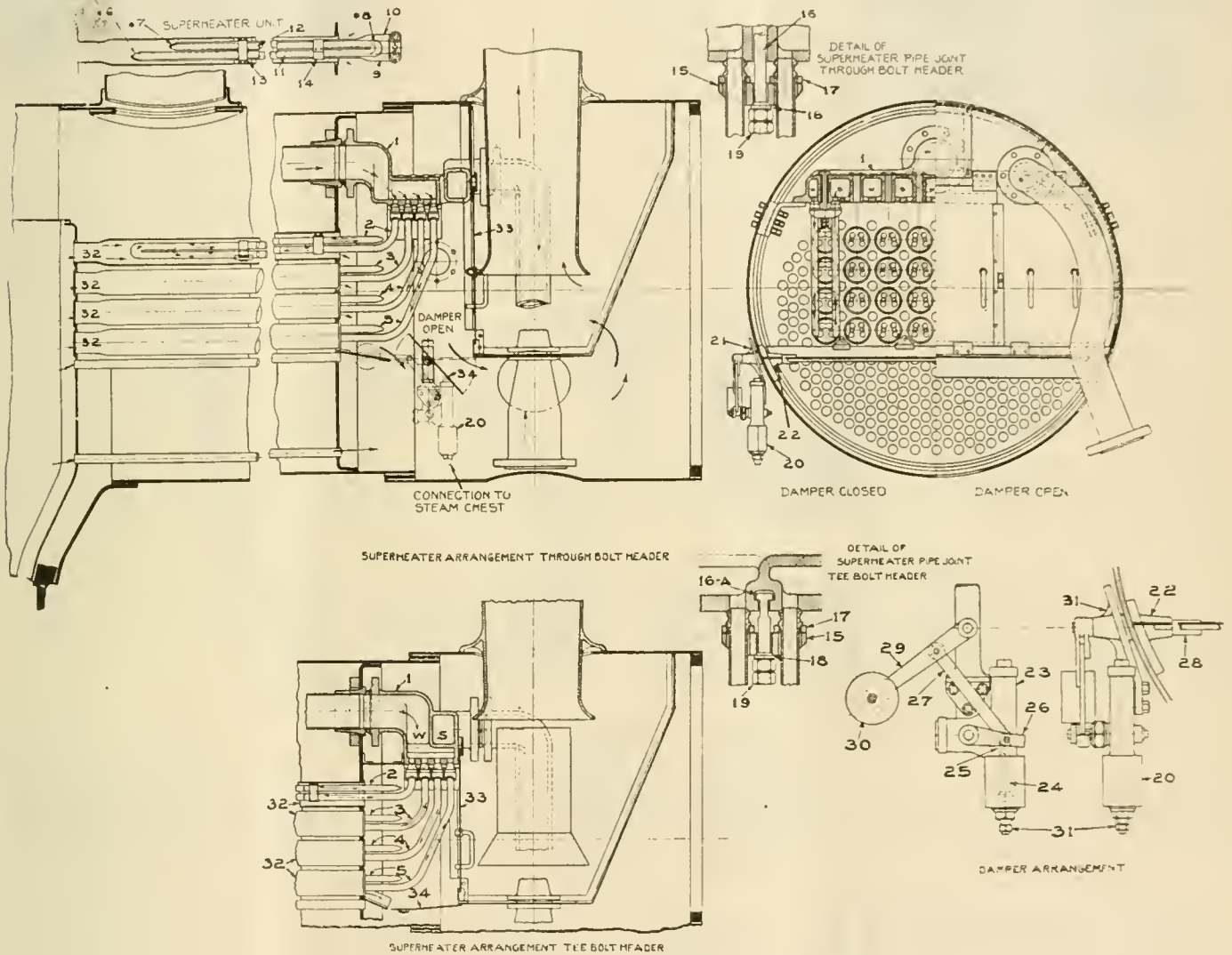

FIG. 4.—DETAILS OF SUPERHEATER APPLIANCES.

sheet, where the flues are reduced, thereby allowing a larger water space. The unit pipes have a welded return bend and the steam is again returned to the proximity of the header, where it is received at a much higher degree of temperature into another compartment of the header, which is so constructed as to form joints with the two branch steam pipes that lead to the cylinders.

It may be stated that this somewhat involved compartment header has undergone several marked improvements. In the earlier forms it was found that the

The joint is a ground ball joint, the concave being in the header and the convex in the pipe collar. The coiled pipes are thus readily removable. The coils of pipes are kept in place near the upper edge of the enlarged flues by means of lugs that rest on the bottom of the enlarged flues, and the unit tubes may be readily withdrawn from their position.

It will thus be seen that the appliance is simply a means of conveying the steam through a series of small pipes to a point as near the fire-box as safety will permit, and by exposing the surface of the small

through the flues with such a degree of heat or force as when the repercussions of the exhausted steam is acting as a blast on the fire, there arises a danger of overheating the coiled pipes. The header and attachments being, as already stated, in the upper part of the boiler, it lends itself readily to its inclosure in a casing, as shown in Fig. 4. In the bottom of this casing, a damper or adjustable lid is engaged to a movable shaft with attachments outside of the smokebox. The normal position of the damper is open when the throttle valve is open. It will be noted

that the appliance connected with the damper has a controlling attachment, to which steam is admitted at such times as when steam is passing into the cylinder. The pressure of the steam at this point causes a partial revolution of the shaft to which the damper is attached, and as long as the steam pressure continues the damper will remain open. When the steam pressure ceases, a counterweight attached to a lever on the shaft has the

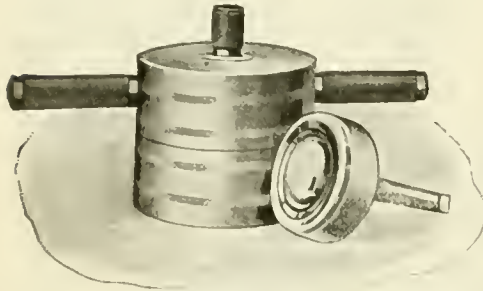

FIG. 5. MOLD SET UP FOR CASTING GRINDING CUPS FOR UNIT ENDS.

immediate effect of closing the damper, and consequently the heated current ceases passing through the inclosed series of flues.

In addition to the form of header described, there are other forms whereby headers are provided separately for each cylinder and located at the sides of the smokebox, instead of at the top, but the internal construction is nearly the same. In the type known as the Comb Header the saturated and superheated steam

As shown in Fig. 4, the parts are numbered and correspond to the designations as used by the Locomotive Superheater Company in the construction of the details of the appliance:

- 1—Header.
- 2—Unit shape, No. 1.
- 3—Unit shape, No. 2.
- 4—Unit shape, No. 3.
- 5—Unit shape, No. 4.
- \*6—Return bend, Style N.
- \*7—Return bend, Style P.
- \*8—Return bend, Style Q.
- 9—Unit pipe, No. 1.
- 10—Unit pipe, No. 2.
- 11—Unit pipe, No. 3.
- 12—Unit pipe, No. 4.
- 13—Pipe support.
- 14—Pipe band.
- 15—Unit clamp.
- 16—Unit bolt (for through bolt header).
- 16A—Unit bolt (for tee bolt header).
- 17—Unit pipe end washer.
- 18—Unit clamp bolt washer.
- 19—Unit bolt nuts (hexagon faced).
- 20—Damper cylinder, complete.
- 21—Damper shaft bearing, outside.
- 22—Damper shaft bearing, inside.
- 23—Damper cylinder body.
- 24—Damper cylinder piston.
- 25—Damper cylinder arm, inside.
- 26—Damper cylinder arm, outside.
- 27—Damper link.
- 28—Damper shaft.
- 29—Damper shaft arm.
- 30—Damper counterweight.
- 31—Damper pipe union (2 per set).

diameter of the ball end of the unit pipe is apparent, and clever devices have been perfected to meet this requirement. Figs. 5 and 6 illustrate molds where grinding spheres of lead or hard babbitt may be readily made, the use of which insure the uniformity of contour. The mold consists of three parts—the base in which the spherical grinder is cast, and the top part of the mold which may be used with

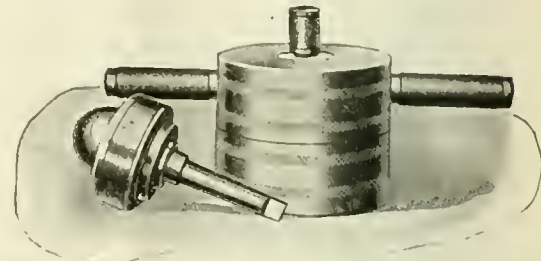

FIG. 6. MOLD SET UP FOR CASTING GRINDING SPHERES FOR SEATS IN HEADERS.

either base. A chuck is provided, which will hold either the cup or spherical grinder, the chuck having a shank suitable for use in an air motor; or a hand brace, the application of which produces perfectly corresponding joints in a very short time.

The most recent improvement in connection with the use of superheated steam is the application in a readily adjustable form of the pyrometer, whereby the engineer can, at all times, be informed as to the temperature of the steam chest. In order to secure a reliable instrument for

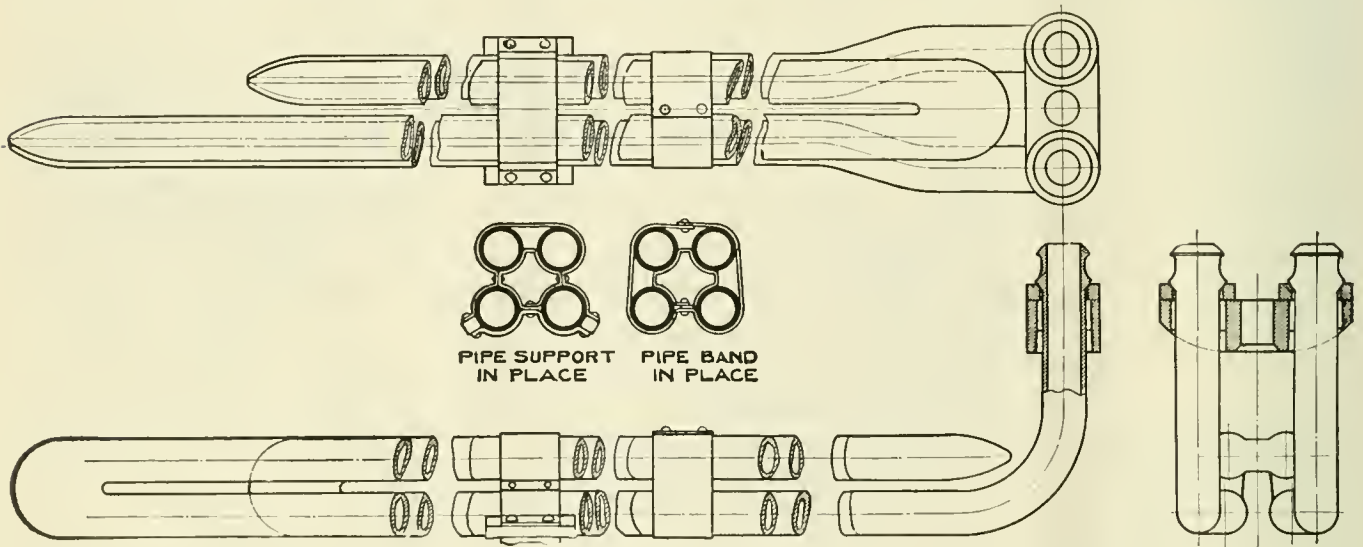

FIG. 7.—TYPE "A" SUPERHEATER UNIT.

headers are completely separated, each header having a main body extending transversely across the front end. The upper or saturated header is connected to the dry pipe as usual, and has sub-headers extending downward. The header for superheated steam is located with its main body down and sub-headers extending upward, and is provided with flanges connecting with the steam pipes.

- 32—Superheater flues.
- 33—Deflecting plate.
- 34—Damper.

In the matter of repair work the most important perhaps is that of keeping the joints tight. To this end the correct ra-

\*Numbers 6, 7 and 8 apply to old style units with cast-steel return bends. In this illustration they refer only to the points at which these bends were located.

this purpose it was necessary to develop one that would meet the strenuous requirements met in the excessive vibration, varying temperatures and atmospheric conditions. An instrument of the electrical type, consisting of thermo couples—the colder end located in the boiler in the saturated steam, and the hot end in the steam chest—securely connected to an indicator located on the gauge bracket in

the cab. The difference in electromotive force generated by the hot and cold ends of the coupler is read directly in degrees Fahrenheit on the dial in the cab, the range being from 250 to 750 degrees. Under average conditions the indicator registers between 600 and 650 degrees. If it falls below this, the water in the boiler may be too high, the fire may not be in proper condition, the superheater flues may be stopped up, or there may be leaks in the front end, or the damper may not be operating properly. As a rule the trouble is not far to look for; the value of the pyrometer being that it indicates the exact conditions, and makes it possible to correct methods of operation, and without an indicator of this kind shortcomings in the best use of superheated steam might go on indefinitely.

In conclusion it should also be stated, in addition to the marked degree of economy in the use of highly superheated steam as compared with saturated steam, that there are remarkable savings not only in coal and water consumption as already pointed out, but in the very

in superheated steam road engines. If we add to this the fact that there is a considerable reduction in smoke in engines using superheated steam, it will be acknowledged that this is an attractive feature in engines in yard and passenger terminal service, particularly in these days when every city has a fool committee clamoring against the insignificant amount of smoke emitted from the steam locomotive.

#### Time Required to Build a Locomotive.

When there were about a dozen separate locomotive building establishments in the country there was some rivalry among them concerning the extent of workmen's labor required to build the standard engine. The time required depended to a great extent upon the tool equipment used and the system adopted. In what was then regarded as the most efficient works the construction of a locomotive required about 1,300 days of labor. In another place it required 1,400 days to do the same work, while in the least

particularly the act created for the valuation of all railway property. In regard to that measure Mr. Elliott says:

"The problem of valuation is a very, very difficult one, and of more importance to the country than one realizes unless one thinks it over very carefully. It has been estimated that the properties of the railways and public utilities under the jurisdiction of the various commissions, Federal and State, are worth about thirty billions of dollars, or one-fifth of the national wealth (\$30,500,000,000). If those who are to make this valuation are unfair, or swayed by personal or political motives and make errors, confidence and credit will be shaken and undermined. The valuation should be fair and take into account all of the conditions. If the valuation is too high, an injustice will be done to the public; and if it is too low, an injustice will be done to the owners of the property. The Constitution and the decisions of the courts up to the present time must be considered in arriving at the valuation of the railways."

We could not do justice to this admira-

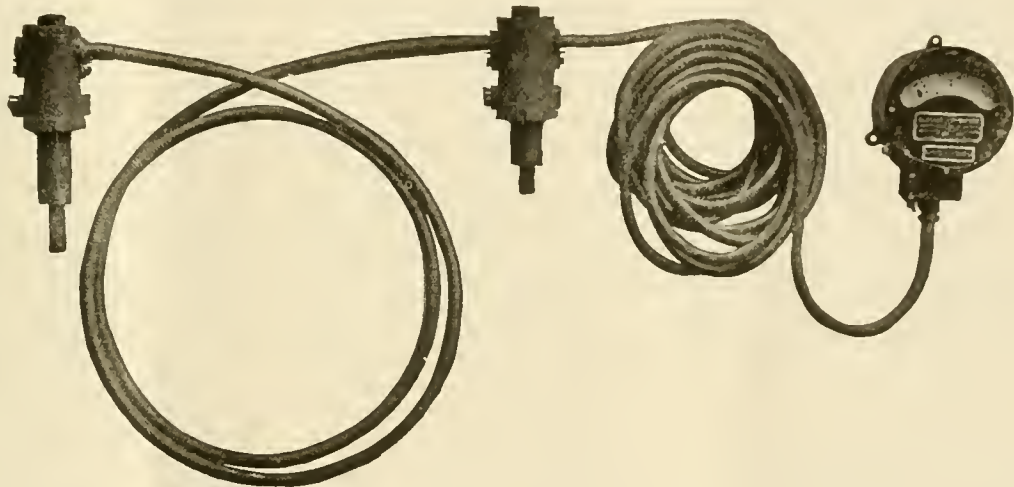

PYROMETER FOR INDICATING TEMPERATURES OF SUPERHEATED STEAM IN LOCOMOTIVE SERVICE.

considerable saving by reason of the increase of the actual working time of the engines while in service on account of the increased interval between the time necessary to take coal and water, each of which represents the loss of time not only in engines working in passenger terminals in large cities, but, perhaps, more particularly in switching engines. This class of engines operating under ordinary conditions using saturated steam have a marked tendency to "work water," and suffer heavy losses from cylinder condensation. These condensation losses not uncommonly attain a magnitude of from 40 to 50 per cent., which represents a corresponding loss in coal. By the use of highly superheated steam in switch engines the loss is entirely eliminated. Actual tests made with switch engines using superheated steam in passenger stations have shown a saving in coal and water far beyond that which is obtained

efficient establishments the building of a first class locomotive represented 2,100 days' labor. From 1,500 to 2,000 days was considered the length of time required to do that work.

#### Federal Valuation of Railways.

Mr. Howard Elliott, president of the New York, New Haven & Hartford Railroad, is an admirable speaker with invariably something to say possessing interest to the public at large and particularly to those who have any connection with railways. He recently delivered an address on "Federal Valuation of Railways" to the American Bankers' Association of Philadelphia, which ought to be read by every person interested in American institutions.

All recent legislation of any consequence relating to railway interests enacted in recent years is referred to or summarized,

able address by publishing extracts, and we strongly advise persons interested to apply to the American Bankers' Association of Philadelphia to send them a copy.

#### Electrification of the New York Central.

The New York assembly on April 20 passed the Thompson bill, authorizing the electrification by January 1, 1919, of the New York Central Lines on the west side of the Borough of Manhattan in New York. The bill has passed the senate, and now goes to the governor for his approval.

#### A Carlyle View.

Carlyle compared the advance of the world to the progress of some drunken man who, reeling from one side of the street to the other, slowly and at the expense of much wasted effort finally arrives at his destination.

## Department of Questions and Answers

### Removing Carbonized Oil from Superheater Valves.

M. H. Hawera, New Zealand, asks: What is the best method of removing carbonized oil from superheated valves? A.—There is no particular method generally recognized as the best, much depending upon the amount of carbonized matter that has been allowed to accumulate. A common practice is to scrape off the collected substance by a suitable scraper, and occasionally in severe cases oxygen may be used to burn the hardened substances that may have accumulated. When the valves can be readily removed a strong solution of potash may be easily applied to the parts that can be conveniently reached. Much may be learned from automobile practice, and experienced chauffeurs use what are known as carbon removers, and large numbers of them are in use in the automobile and gasoline motor industry. The apparatus consists of a high pressure oxygen cylinder with automatic reduction valve, usually constructed on the diaphragm principle, thus assuring positive regulation of pressure. This valve is fitted with a pressure gauge, rubber hose and decarbonizing torch with shut-off and flexible tube for insertion into the chamber from which the carbon is to be removed. An asbestos swab is also useful for swabbing out the inside of the cylinder with kerosene previous to starting the operation. The action consists in the stream of oxygen burning the carbon to a fine dust when the dust can be blown out. The swab may be used to ignite the gas in the cylinder in place of using a match or taper. There is usually a considerable display of sparks, but they will not set fire to the grease and oil. When the burning ceases the carbon has been removed.

### Testing of Boilers and Their Accessories.

L. D., Scranton, Pa., writes: After giving a boiler a hydrostatic test is it necessary to inspect the other parts of the boiler, or would the hydrostatic be enough? (2) How much greater pressure is applied on a boiler than it is supposed to carry at the working pressure? A.—(1) All the attachments of the boiler should be carefully examined and refitted if necessary. (2) Twenty-five per cent.

It may be noted that copies of the locomotive inspection rules may be had on application to Mr. Frank McManamy, Chief Inspector of Locomotive Boilers, Interstate Commerce Commission, Washington, D. C.

### Trouble in Charging Freight Train.

P. V. B. Holloway, Ohio, writes: I am having some trouble with the air

brakes on an engine, the engineer reports that he cannot pump up the pressure in the brake system of a 50-car train with the brake valve handle in running position, and must use full release position in order to maintain the pressure in the brake pipe. With the lone engine or engine and five cars, the pressures are pumped up to 70 and 90 pounds, but the brake pipe cannot be charged on a longer train. Engine is equipped with the G-6 brake valve, B-6 feed valve and the excess pressure governor top. Could you tell me where to look for this trouble?

A.—You are, no doubt, aware, and the engineer should be, that with the excess pressure governor top it is necessary to charge a long train with the brake valve handle in release position, for when the brake valve is placed in running position the brake pipe pressure is absorbed by the triple valve feed grooves at a faster rate than it can pass through the feed valve, then with a large capacity air compressor, the air pressure is accumulated in the main reservoir at a faster rate than it can flow through the feed valve, and as a result the pressure under the diaphragm of the excess pressure governor top becomes more than 20 pounds higher than the pressure above the diaphragm, which is brake pipe pressure, and the diaphragm valve is unseated and the governor stops the compressors, until such time as the feed valve can build the brake pipe pressure up to within 20 pounds of that in the main reservoir, hence to avoid this action, release position of the brake valve is used for charging the brake system of a long train.

If, however, the pressure cannot be maintained after the auxiliary reservoirs are charged, it indicates that the pressure is leaving the brake pipe at a faster rate than it can flow through the feed valve, whether this is due to brake pipe leakage or to a defective feed valve or a restriction to the flow of air pressure to the feed valve, provided that the pressures are correctly adjusted and the air gages are correct.

As the train can be charged with the valve handle in release position it proves that the brake pipe is unobstructed, and that the diaphragm valve of the governor is not stuck open, therefore we would suggest that you first see that the air gage is correct, and the difference between brake pipe pressure is at least 20 pounds, as compared with main reservoir pressure, this for the reason that the tension of the supply valve piston spring of the feed valve is as much as 7 pounds, and other slight disorders of the feed valve may require as much as 12 pounds difference in pressure to operate it, that is, if the air gage was 10 pounds out (either heavy on the brake pipe hand or light on the main reservoir hand) the

feed valve could not be expected to operate correctly.

When this is known to be correct, replace the feed valve by one known by test to be in good condition, examine the ports in the brake valve leading to the feed valve for an obstruction (ports f and i) and see that the excess pressure governor top is operating correctly, and your trouble will doubtless be overcome.

### Repairing Air Pump Heads.

W. H. B., St. Louis, Mo., writes: (1) What is generally considered to be the most economical practice that can be followed in overhauling the top head of the 9½-inch air pumps to rebush the main valve bushing and the left main valve cylinder head and maintain a standard size of piston rings or to merely rebore these parts and use larger than standard pistons and rings? (2) What is considered to be the best practice in overhauling the top head of the cross compound compressor? A.—(1) We have no figures upon which to base a definite answer to your first question, and an accurate answer would depend somewhat upon the kind of a machine shop in which the pump head is to be repaired, but we favor the method of reboring and using a size larger main valve piston and rings, for the reason that the main valve pistons will become too small for use from wear and the grooves will be worn, therefore a new piston can be purchased a size larger for the same price as the standard size, which will avoid the actual necessity for rebushing the parts. Just how many sizes of pistons should be used or how many times the bushing may be rebored before it should be scrapped is also a matter that is open to discussion, but by the time the bushing is rebored twice in steps of 1/16 the valve seat will generally be found to be worn and filed down pretty well so that very little further service is lost by scrapping the valve. The left main valve cylinder head is not so expensive and after two reborings no great loss will result in scrapping it, while the purchase of new pistons of different sizes will enable the storekeeper to maintain a standard width of main valve piston rings, which is very desirable. (2) Inasmuch as bushings are furnished by the air brake company for the left main valve cylinder head as well as for the large piston end of the head and the main valve, that can be pressed or driven into place without any turning or fitting, and on account of the comparatively low cost of the main valve bushing, experiments made so far indicate that the most economical method is to renew these bushings when worn to such an extent that new rings should not be fitted and that the main valve piston and rings should be maintained a standard size. We have never attempted to



rebuild the main valve bushing of the cross compound pump on account of its comparatively small cost and for the reason that it can be removed or replaced without the necessity of doing any machine work.

#### Pump Governor Trouble.

A. H. C., Wilmington, N. C., writes: I am running an engine equipped with the No. 6 E. T. brake and two 9½-inch air pumps and we have a separate line of pipe running from the main reservoir to the pilot and to the rear of the tender where in coupling up to another engine in double heading the head man can use the main reservoir volume and the air pumps of both engines. We haul as many as 125 cars with the two engines and when I am on the second engine of a double header I notice that during a release of brakes the pumps on the second engine stop and will not start for a long time after those on the first engine. Will you please tell me what causes the pumps to stop and what arrangement can be made to prevent this? A. The pumps are stopped by the action of the excess pressure governor top, because for some reason the difference in pressure between that in the main reservoir and that on top of the diaphragms in the excess pressure top is greater than the tension of the regulating spring of the excess pressure governor top, that is, the main reservoir pressure is more than 20 pounds higher than the pressure in the excess pressure pipe. This is usually caused by a defective feed valve in combination with a small leak in the feed valve pipe or its connections, and with troubles of this kind it should be remembered that the air gages, through being inaccurate, may not show the actual difference in pressure that may exist and that the tension of the supply valve piston spring of the feed valve ranges from about 7 to 12 pounds in difference in pressure. There is also a possibility of the pipe connections being wrong, that is, the brake pipe gage pipe may have been connected to the excess pressure top of the governor and the black hand of the small air gage may have been connected with the feed valve pipe; this, however, would be noticed as soon as the engine is alone as the black hand of the small gage would not fall when a brake pipe reduction is made.

Under such conditions you would keep your pumps in operation by placing the automatic brake valve on lap position, which will cut off the main reservoir pressure from the excess pressure governor top. Probably you have been instructed to assist the head engineer in making a stop by holding on your driver brake to assist him in holding in the train slack during a release of brakes, then instead of using the independent valve for this purpose, use the automatic valve, and

provided that the air pipes are correctly connected, report the air gages to be tested and the feed valve to be cleaned and tested at the end of the trip.

#### Defective Type L Triple Valve.

W. B. A., Jacksonville, Fla., writes: What is the effect of a leaky by-pass valve in the type L triple valve and how can the leaky valve be detected on a car in a train? A.—It depends upon whether or not the supplementary reservoir is cut in. If the supplementary reservoir of the LN equipment is not in use a leaky by-pass valve of the L triple valve will have no effect whatever on the operation of the brake and the leaky valve cannot be detected from the brake operation on a train of cars. If, however, the supplementary reservoir is in use, a leaky by-pass valve will admit supplementary reservoir pressure to the auxiliary reservoir.

When the pressure in the auxiliary reservoir is lower than that in the supplementary reservoir, and as this condition exists during a service brake application, the leakage into the auxiliary reservoir results in a higher brake cylinder pressure than was intended, tending to produce slid flat wheels and during the release of such a brake the supplementary reservoir pressure leaking into the auxiliary reservoir, tends to prevent the triple valve from being moved to release position thus causing stuck brakes and other air brake disorders. A leaky by-pass valve in a triple valve in a train of cars can be detected by having a 20-lb. brake pipe reduction made, and if the safety valve of one triple valve opens shortly after the brake valve reduction ceases and continues to "pop" while none of the rest open, it is an indication that the by-pass valve of that triple valve is leaking. Under this condition, all brake cylinders receive about 50 lbs. pressure as a result of the 20-lb. reduction then the leaky by-pass valve continues to leak air pressure into the auxiliary reservoir, which in turn moves the triple valve to admit this amount into the brake cylinder which in a short time raises the brake cylinder pressure up to the adjustment of the safety valve; this is of course assuming that the leakage past the defective valve is of a sufficient volume or that the brake cylinder leather or connections do not leak at the same rate that the by-pass valve is leaking into the auxiliary reservoir.

#### Recharge of Passenger Car Brakes.

F. R. K., Ludlow, Ky., writes: I am an interested reader of RAILWAY AND LOCOMOTIVE ENGINEERING, especially the Air Brake Department, and I would like to ask you if it is not a fact that there is a certain time after a service brake application in which a passenger train is not under the control of the engineer;

that is, during the time that elapses between the movement of the brake valve to release position and the complete recharge of the auxiliary reservoir subsequent to another brake application? A.—We do not think that there is, as with all modern brake equipments the auxiliary reservoir is charged at the same rate as the brake pipe pressure is increased. With the L.N. equipment this recharge for the auxiliary reservoir is from the supplementary reservoir on the car, and with the P.C. equipment the service reservoir is recharged from the emergency reservoir after a release of brakes, and with the U.C. equipment, the recharge for the auxiliary reservoir is taken from the quick recharge or emergency reservoir.

There are, however, times, especially during a transition period, when these features are not employed, but even so, there is no element of danger encountered as even with the high speed brake of twenty years ago, a full service brake pipe reduction still leaves 90 lbs. pressure in the auxiliary reservoir so that a case of emergency following immediately after a service reduction enables the engineer to almost instantly raise the brake cylinder pressure to the adjustment of the high speed reducing valve, which is 60 lbs.

Granted that there is a possibility of some passenger trains being operated with but 70 lbs. brake pipe pressure, the element of safety is not so pronounced, but this is no fault of the brake equipment, and with all modern brake equipments, a feature is, "Full emergency braking power at any time" during or following a service brake application.

#### Bells.

Bells have been employed in association with religious worship since the early days of Egypt. Cymbals and hand bells and small crotals served for the festival of Isis. Aaron and other Jewish high priests wore bells of gold upon their raiment. In camp and garrison the Greeks employed bells. The Romans announced the hour of bathing by their melody. Copper and tin, the old composition, is still regarded as the best bell metal. Steel has been tried, but does not make a successful bell. Glass bells are mellow and beautiful in tone, but the material is too fragile. The one metal which is impossible is that which everybody imagines makes the best bell—silver.

#### The Railroad Wages Question.

The Chamber of Commerce of the United States has ordered a referendum to be taken on a proposal to ask Congress to call upon the Interstate Commerce Commission to investigate at once the demands of railway employees for higher pay.

# Railway & Locomotive Engineering

A Practical Journal of Motive Power, Rolling Stock and Appliances.

Published Monthly by

## ANGUS SINCLAIR CO.

114 Liberty St., New York.

Telephone, 746 Rector.

Cable Address, "Locong," N. Y.  
Glasgow, "Locoauto."

### Business Department:

ANGUS SINCLAIR, D. E., Prest. and Treas.  
JAMES KENNEDY, Vice-Prest.  
HARRY A. KENNEY, Secy. and Gen. Mgr.

### Editorial Department:

ANGUS SINCLAIR, D. E., Editor.  
JAMES KENNEDY, Managing Editor.  
GEO. W. KIEHM, Associate Editor.

### London Representative:

THE LOCOMOTIVE PUBLISHING CO., Ltd.,  
8 Amen Corner, Paternoster Row, London, E. C.

### Glasgow Representative:

A. F. SINCLAIR, 15 Manor Road, Bellahouston,  
Glasgow.

### SUBSCRIPTION PRICE

\$2.00 per year, \$1.00 for six months, postage paid in the United States, Canada and Mexico. For other parts of the world, \$2.50, or ten shillings. Single copies, 20 cents. Remit by Express Money Order, Draft, Post Office Order or Registered Letter.

Mailing address can be changed as often as necessary—always give old and new address, and if you subscribe in a club, state the name of the agent.

Please give prompt notice when your paper fails to reach you regularly.

Entered at the Post Office, New York, as Second-class Mail Matter.

### Cylinder Condensation.

We consider that the most recent methods employed in adding extra heat to the steam used by locomotives is the greatest improvement effected on that form of steam engine since William Hedley first built an engine capable of moving cars over a railway. When the hot steam from the boiler enters the cylinder a certain amount of condensation of the steam ensues, due to the cooling effects of the cold metal of the cylinders, which causes serious reduction of efficiency. Kinnear Clark, the famous Scotch engineer who made exhaustive experiments on the locomotive, asserted that the loss from cylinder condensation sometimes amounted to as high as 50 per cent. of the steam passing from the boilers.

Ever since the engineering world came to understand how serious were the heat

losses due to cylinder condensation, all sorts of attempts have been made to prevent that waste of heat, but in the case of the locomotive no real remedy was ever found until inventors resorted to the modern practice of superheating the steam before it was allowed to touch the metal of the cylinders. In stationary engine practice steam jacketing the cylinders has been very successfully resorted to and has proved a real success, but similar inventions have failed when applied to locomotives. George Richards, inventor of the well-known safety valve, and Frank F. Hemenway, author of the well-known book on the steam engine Indicator, both held decided views concerning the heat loss due to cylinder condensation, and they secured the use of a locomotive from a leading railroad and conducted most exhaustive experiments on methods of superheating the cylinders. They succeeded by passing exhaust gases in raising the temperature of the cylinders higher than the incoming steam, but yet they failed to prevent cylinder condensation or to reduce the fuel consumption. The writer, while running a locomotive on a railway in Iowa, devised an arrangement for passing the fuel gases around the cylinders and it appeared to operate all right so far as heating the cylinder was concerned, but it did not reduce the coal consumption.

Saturated steam is constantly on the dew point, and on the least portion of the heat of vaporization being taken away, a corresponding portion of the steam falls into water just as it acts on a large scale in a condenser. In fact all steam cylinders act as condensers to a greater or less extent, and some of them appear to be more efficient as a means of converting steam into water than as a means of transforming the heat of steam into mechanical energy. When steam returns to its original condition of water, it loses its power to perform mechanical work in the cylinders, therefore the percentage of steam that condenses in the cylinders represents so much loss of power.

Although it is impracticable to make a cylinder receive and exhaust steam without other loss than that converted into mechanical work, the scientific world has labored continually to make the heat losses as low as possible, and the practice of superheating the steam before it enters the cylinders has been most successful. Numerous insuperable obstacles stand in the way of admitting steam without loss or diminution of pressure into a cylinder made of conductive materials, or to exhaust it without back pressure.

The serious losses that occur in the steam engine cylinder through condensation has been well known to steam engineers for years, yet the men who have been responsible for leaving the loco-

motive cylinders badly exposed to refrigerating influences have been very slow to realize the extent of waste caused thereby. Steam jacketing is impracticable for locomotives, but good lagging is not, and there are few locomotives that have their cylinders so well protected by that means as they might be, but the real remedy for cylinder condensation is putting extra heat into the steam before it enters the cylinders.

Questions relating to heat, steam, electricity, hydraulics, pneumatics, and all other lines connected with engineering science have been exhaustively investigated con amore by many men of commanding ability and monumental industry. Their discoveries are all open to men who keep themselves in touch with current lines of progress. While investigating the action of steam driving a piston it is sometimes necessary to assume that steam can be admitted without loss of heat or diminution of pressure into a cylinder made of conductive material, or to exhaust it without back pressure; and to render clear certain calculations respecting the manipulation of steam, it is convenient to assume that other impracticable operations are possible. Many valuable and interesting laws, facts and figures relating to the behaviour and action of steam which the engineering world accepts as being absolutely correct, could not be demonstrated with any degree of accuracy in the ordinary practical working of the steam engine. They are the discoveries and calculations of physicists and mathematicians who have devoted laborious and special investigation to the subject, aided by ingeniously designed apparatus. To such investigations are due all the facts known about cylinder condensation and the merits of superheating.

No theory of the steam engine can have any value which is not based on the fact of cylinder condensation, by the interacting of the metal, and on the variations in the quantity of that condensation due to different conditions. Nothing else will explain the results of steam engineering, and here the properties of matter must be considered in connection with abstract laws if practical results are to be predicted or even understood.

### Superficial Efforts of Heat.

It is true of almost every body—the solid, the liquid or the gaseous—that the addition of heat causes expansion, but it is also true that with almost every body, at the initial periods of change of state from the solid to the liquid, or from the liquid to the gaseous, there is an absorption or disappearance of the heat which may be put into it, which heat can only be made to reappear when the body is allowed or compelled to resume the solid state.

Solids expand by the addition of heat, though in less proportion than gases. An instance familiar to those of us who are engineers is afforded when we have to deal with a cast-iron steam pipe of great length, subjected as steam pipes are to considerable variations of temperature. We know that in a pipe of a length of 800 feet we have to allow for a variety of, roughly, one foot for each difference of 200 degrees Fahr. of temperature to which the pipe will be exposed.

The effect of variations of temperature is familiar to all observers in the ordinary mercurial thermometer. Heat causes the liquid mercury to expand or dilate, cold causes it to contract. The expansions of the steam pipe and of the mercury, however, are small in comparison with the expansion of gases, steam, air, or whatever they may be, for an equal increase of temperature.

#### High Voltage in Railway Service.

The American Institute of Electrical Engineers publish in the April issue of its proceedings an excellent paper presented by Mr. C. Renshaw, in the course of which it is pointed out that much higher voltages than at present in use have been shown to be practicable. The paper deals with the fundamental differences in apparatus for 1,200 or 1,500 volts as compared with the former 600-volt standards, and points to the comparative ease with which the increase was made, and suggests the employment of still higher voltages.

From a technical standpoint there was apparently no particular difficulty in doing this, and one line installed so as to operate 2,400 volts, has had a remarkably successful record. From a general standpoint, however, while the results have been welcome as a contribution to the development of the art, suitable applications for this particular voltage are apparently somewhat lacking. It has the inherent disadvantage of requiring apparatus which departs too widely from the existing standards with which the operating forces have become familiar, as well as of not lending itself to interchangeable operation over 600-volt lines. For heavy traction, on the other hand, this voltage is much too low to solve the problem in a sufficiently comprehensive way to attract the investment of capital in electrification. Even 3,000 volts, while overcoming the later disadvantage to some extent, does not do so completely. It is regrettable also that both 2,400 and 3,000 volts have been employed and that in carrying on the upward progress in d-c. voltages, 1,500-volt apparatus was not used at once for coupling in series, for carrying on the geometric progression, without the intermediate 2,400-volt step.

The general limits upon which standard practice in any industry ordinarily

settles are usually fixed by broad economic considerations rather than by physical limitations. It is entirely possible for instance to operate trains at maximum speeds of 90 miles per hour or more, yet the maximum ordinarily attained is from 60 to 80 miles per hour. Physically speaking, also, interurban cars can be run at speeds similar to these, yet the general average on such roads is from 50 to 60 miles per hour. These values have been established by gradual increases from lower ones until without any conscious effort, standardization has been automatically secured.

In the voltages which may be employed with the d-c. railway system, there is some tendency toward this same procedure. If no efforts were made to the contrary, it is not improbable that starting from the voltage of 3,000, which we have today on the Chicago, Milwaukee & St. Paul, we would next hear of the employment of 3,600 volts, then possibly 4,200 volts, and so on up in corresponding steps. Sooner or later, however, a point would be reached where, by common consent, these increases would stop just as this has happened in the matter of speeds.

While in a way, such a procedure would be the conservative and natural way for progress to come about in the use of higher d-c. voltages, its disadvantages are too obvious to require mention. The apparently more radical plan of trying to select in advance the voltage at which such increases would naturally stop and of going at once to this voltage would hence seem to be the more rational and really the more conservative as far as the general good of the industry is concerned. It has been with this idea in view that the efforts toward the use of direct current at 5,000 volts are being put forth. With practical apparatus for this voltage available, the problems of distributing and collecting the necessary power for the largest locomotives likely to be required can be readily solved so that although further increases might be possible, they should be entirely unnecessary.

#### Curious Rates Dispute.

A curious conflict has arisen between the railways of this country and the Interstate Commerce Commission. The Panama Canal was closed during some months of last year. During that time the Interstate Commerce Commission allowed the railways to reduce rates to meet water competition. Meanwhile water freights so advanced throughout the world on account of the war that the conditions of competition made the reduction of railway rates unnecessary, the water rates being higher than those charged by the railways. The expectation was that the railways would hasten

to seize the opportunity that the law permitted of raising the rates, but that they have refused to do, and it has left the commission in an awkward dilemma. Proceedings have been instituted to compel the railways to raise their rates, and that has raised a tumult among shippers who prefer to have their transportation performed at the lowest rates the law allows.

The habits of freight shippers have always been to do all in their power to induce the Interstate Commerce Commission to do all in their power to reduce freight rates. It has been always understood that the commission was particularly friendly to shippers, but now the same shippers are howling for protection from what used to be their peculiar friend, the commission, and delivered into the hands of their old time enemies, the railways.

Commenting upon this subject, the *New York Times* says: "The tangle seems inextricable, but not for that reason should regulation be despaired of. The politicians will be the last to allow the quarrel to be composed. Their interest lies in agitation, and in befriending the shippers against the extortions of the railways. That was the popular view to take when the shippers were distressed and the railways were too prosperous. Now the shippers' profits are limited by the accommodations the prostrate railways are unable to increase. Abuses should not be condoned, principles should not be abandoned. But contentions and debatable questions might well be softened for a while. Railways and shippers might make a short circuit, and put politicians, courts and commissions out of business by settling their own disputes between themselves."

#### The Reading Youngster.

The young fireman who wishes to learn his business, and aims to acquire all there is to learn about it; and the ambitious apprentice boy in a machine shop who acquires a taste for reading the literature that deals with the work they are engaged doing are to be envied by youths whose minds never stray beyond the literature of the ball game. The reading young man apprentice, fireman or brakeman finds the literature of his business full of novelties that attract and amuse, while all the time he is imbibing instruction that may become valuable capital in after years. A famous engineer writer, noted for his rare experience and good sense, says:

"The apprentice in a machine shop with an inclination toward reading engineering literature finds in the simplest every-day matter a subject of novelty to himself, and in the course of time his mind becomes stocked with material gathered there item by item, each one as old as the hills to the world, but as fresh as the daisies to him.

"An apprentice boy sits on a block at noon, reading a mechanical paper, and is thoroughly interested in an illustrated article on lining up engine guides. Some old, gray-haired fellow looks over his shoulder, gets a general idea of the illustration, and sneeringly remarks to the boy: 'Pshaw! that thing's a thousand years old. Is that what you fellows read about in them papers?' If the boy is smart, he will reply: 'I am 14 years old and this is the first I ever knew about this guide business. How old were you when you found it out?'"

"When this same boy gets to be, say, 50 years old, he may possibly become disgusted with this kind of shop literature, and begin to think that the editor is foolish for putting such old things in the paper, thinking they can be passed off as novelties. He may forget his own experience.

"Professional literature forms the annals of professional progress. The artisan's literature is not and need not be consecutive in any of its arrangement. It presents a series of items which each individual arranges in his own mind for his own independent annals of progress."

We have among our readers the apprentice boy and the old workman, also the fireman and the old engineer. Behind them are the men of other years who will not suffer from having old stories told in new words. Men forget things so quickly that old memories will stand feeding with the old knowledge that is new to the younger generation.

#### A Mysterious Pound.

Some years ago the writer had a day run on a line in Illinois, that is a run of fifty miles enabled him to make the trip and return to headquarters every day. The master mechanic took in his head one day that I possessed unusual opportunities for breaking in new firemen and for making testing trips with engines newly out of the shop. The experience so gained was valuable and diverse, but three months of it made me ready for permanent retirement.

The general repairs were done in a painfully superficial manner and I found that some of the engines newly out of the shop were really in need of a general overhauling. The repairs consisted generally of what was called a round-house rebuild—guides closed, rod brasses reduced and stack painted. The engine crew was then told that the engine was good to be kept on the road for two years.

On the first trip that I had one of those engines breaking in she crawled up hill without making any fuss, but when the train began to drop down the hill the engine proceeded to produce a succession of pounds that made me conclude that she had broken a frame or a driving axle. An examina-

tion of the machine revealed nothing wrong. There was no appearance of anything being broken. I started up again and all went well as long as steam was used, but on the throttle being closed the pounding began again. Experience had taught me where to locate the trouble. It was on the right-hand cylinder and I concluded that the piston was striking the head when steam was shut off. On close examination I found that to be the case. When using steam the piston was held back so that it did not strike the head. Putting in a liner ended the trouble.

The difficulties that arose connected with the testing of new firemen makes another edifying story.

#### Superstitions of Enginemen.

A hazardous occupation has a tendency to make people engaged upon it superstitious, yet there are few really superstitious men among locomotive engineers, although some of them believe in such absurdities as certain engines being unlucky, when there is one accident there are surely to be three, etc. A good many of those half-developed beliefs are inherited by firemen from old engineers. That some certain engine may have had more accidents than others is no reason why it should continue to have them. People who are inclined to be superstitious will be sure to mention the fact that an engine which fell through a bridge came out of the shop on a Friday if she did, but always forget to count up the other wrecked engines that did not come out of the shop on that unlucky day. They also forget to count up the many mishaps that come singly, but let three of them come together and then the "I told you so's" are thick.

The writer was in the office of a master mechanic once when a young engineer applied for a position. The master mechanic looked at him for a minute and said: "I have nothing for you unless you are willing to run an unlucky engine. The 79 has been running only two years and has killed three engineers and been rebuilt twice. The boys call her the 'man killer.' She will be out of the shop tomorrow and not a man on the division wants her."

"I would rather have her than any old engine you've got. I don't believe in spooks," said the engineer.

The master mechanic was favorably impressed by the position taken by that engineer and gave him the so-called unlucky engine. That was three years ago and he has been running that and other engines ever since without any mishap.

A bridge that wants to burn or a freshet ready to wash out the track will not wait for any particular engine. Don't be superstitious, boys, for that

brings discomfort without increasing safety.

#### Book Reviews.

**Locomotive Dictionary**—Compiled and edited by Roy V. Wright and George Mitchell, 962 pages, cloth.

The fourth edition of this important work has just been published by Simmons-Boardman Publishing Company, New York, and contains 962 pages, being more than 400 pages larger than the edition of 1912. In comparing the previous edition with that just issued one is amazed at the number and variety of new devices embracing important improvements on the modern locomotive which the book presents in thousands of illustrations, and also valuable descriptive matter, and it is safe to say that at no period of the development of the locomotive has such real progress been made. The older editions are therefore, properly speaking, of little value to those who desire to keep advised as to the latest details in locomotives and their attachments. As is well known, only a few years ago an increase in the hauling power of the locomotive was obtained mostly by an increase in size with little or no consideration of those devices which today are essential to the economical use of high-powered locomotives. Many of the chief organic changes in construction have been made possible by the marked improvement of special alloy steel resulting in a reduction in the weight of many of the parts, with lighter counterbalancing, and a considerable increase to the possible wheel load. Hence the necessity had arisen to completely revise the book. Not only so, but there are entirely new sections devoted to gasoline engines, pulverized fuel, systems of combustion, electric and compressed air devices, and other details until recently practically unknown. To this is added an important section setting forth special tools used in construction and repair so that the book contains all that is now known of American locomotive design and construction. The illustrations are of the best, while the letter press is excellent. The McGraw-Hill Book Company, New York, are the selling agents, and the price of the book in cloth covers is \$4.00.

**Statistics of Common Carriers**—230 pages. Paper covers.

The fifth annual volume of this book issued by the Interstate Commerce Commission presents in detail the statistics in regard to the income and operating expenses of all of the railways in America having operating revenues of over \$1,000,000 a year. The principal express companies and the Pullman company are also classified. Copies of the book may be had from the Superintendent of Documents, Government Printing Office, Washington, D. C. Price 35 cents per copy.

# Locomotive Running Repairs

By JAMES KENNEDY

## VIII.—Fitting and Refitting a Throttle Valve and Its Connections

The balanced throttle valve in various forms has long ago taken its proper place as one of the nearly perfected attachments of the modern locomotive, and in point of constructive detail it admirably meets the requirements of the situation. If it has a fault it is in the cheap material of which it is generally constructed. It is a matter of regret that so many leaky throttle valves are to be contended with, and while it is to be feared that many of our railroad machinists do not give the thought and attention to the grinding and fitting and adjustment of the throttle valve that they might do if possessed of more serious consideration.

Indeed it has not infrequently been observed that when locomotives are placed in the shop for general repairs the throttle valve will be found to be perfectly tight, the valve and seat having become finally fitted to each other by the mere force of attrition. After some skilled mechanic has spent some time to no good purpose in refitting it, the valve will be found leaking and will continue leaking until it refits itself. It would be idle, however, to assume that if the valve had been left alone it would have remained tight, as it is more than likely that the variations in the degrees of hardness in the metal composing the valve seat had caused some degree of irregularity which the simple turning around of the valve, if such a change happened in the course of examination, would materially disturb.

Those acquainted with the varying degrees of hardness in castings of irregular thickness need hardly be reminded that the throttle pipe or stand pipe, as it is frequently called, is of much greater thickness on that portion of the casting where it is attached to the brace in the dome than it is on the portion furthest removed from the brace and which forms the rim on the valve seat. This variation in the thickness of the metal affects the wearing quality of the valve seat and valve very materially. Such variation in the hardness of castings are more readily observed in the wear of cylinders where the thick walls of the cylinders adjacent to the frames are softer than the thinner outer walls of the cylinders. Those who are familiar with the operation of boring cut cylinders have, no doubt, observed the greater degree of wear of the thicker sides of the cylinders. In grinding and refitting a throttle valve it will be seen, after the first application of the oil and emery, that the wear has been greater on the thicker side of the valve seat, a portion of the bearing very likely remaining untouched.

In grinding the valve, particular care should be taken that the mechanic doing the job should not remain long in one position, nor allow the valve to remain long in the same relation to position on the valve spindle. The tendency to exert pressure in other than an exactly vertical direction is very great, and the pernicious effect of this is obviated if the mechanic moves around the dome instead of fixedly seating himself in one place. The valve should be raised from the seat every few turns, and it is not necessary at any time to exert much weight upon the grinding spindle.

It is generally believed that the upper or larger area of the valve bearing should be left somewhat lighter than the lower bearing, as the expansion of the metal when heated under high steam pressure,

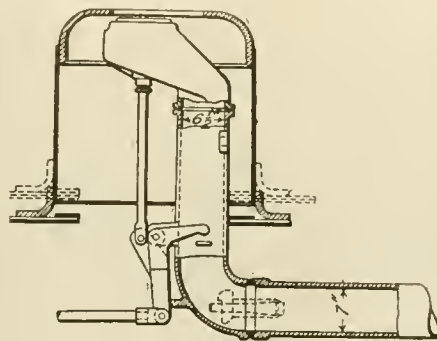

THROTTLE VALVE AND CONNECTION.

must be greater than in the lower bearing. It should be remembered, however, that is also true of the bearing as well as of the valve. The bearing will expand equally with the valve, so that any allowance for this cause should not be seriously considered.

Among the various tests as to the tightness of the joints after grinding, the air test, if convenient, is very simple and reliable. Chalk or pencil marks are also good tests, if the valve be placed in the proper position and slightly moved. If turned a complete revolution, the test is of no value, as in making a revolution all the parts of the face of the valve will touch somewhere. It is well that from the beginning of the operation of fitting, the front and back of the valve should be definitely marked, as a change of position in the final testing of the fit materially affects the perfect fit of the valve to the bearing.

Of importance also is the careful fitting of the throttle rod and its attachments. We need hardly remark that it is the steam pressure that closes the balanced valve. The lever and throttle rod should

be so adjusted that when connected to the valve crank, the crank should strike the projection usually provided on the stand pipe before the lever has reached the end of the rack or quadrant. It is good practice to stop in the third or fourth notch from the end, as the accumulating lost motion arising from long service gradually brings the lever further toward the end of the rack. In this position the valve spindle should be fitted with a slight opening at the shoulder underneath as well as at the washer or nut on the top of the spindle. The amount of opening need not exceed a thickness of paper, but it should be sufficient to avoid any possibility of the throttle rod tightening the valve spindle on the valve. It should be noted that the pins are all thoroughly fitted to their connections and properly kept in place by cotter pins.

In conclusion it may be added that after completing the fitting of the throttle valve and lever and throttle rod, which should all be done by one skilled mechanic, thereby avoiding any divided responsibility, the throttle lever should be disconnected until the engine is ready to be fired up and out of the shop. The tendency among unskilled railroad men, and others, who get access to the cab of a locomotive, is to move the throttle out of mere idle curiosity. All engineers know how to open and shut a throttle valve; many others do not. Sometimes managers and superintendents and their satellites do—not also.

In conclusion it may be added that while reference has only been made to the common form of throttle valve, there are in operation several improved forms of throttle valves, among which the Chamber's compensating throttle valve is growing in popular favor, and all of which are possessed of clever improvements calculated to meet the growing requirements of modern locomotive service.

Some of these devices are intended to maintain lubrication while the locomotive is drifting with the steam shut off, and are automatic in action, and all are easily understood by the skilled mechanic who is familiar with the ordinary throttle valve and its connections.

### Removing Paint from Iron

Many experiments have shown that a paint softener made of one pound of lime to four pounds of potash mixed with six quarts of water will have the desired effect as quickly as many more costly preparations.

# Mikado Type Locomotives for the Raritan River Railroad, and Mikado Locomotives for the Lehigh & Hudson River Railway

The main line of the Raritan River Railroad extends from South Amboy to New Brunswick, N. J., a distance of 12.3 miles. It serves a busy industrial section and has direct connections with two important trunk lines; so that, although the mileage operated is small, the road handles a large amount of important business, both freight and passenger. During the past year traffic has been increasing to an unusual extent; and the company has recently purchased, from the Baldwin Locomotive Works, five Mikado type locomotives, one of which is shown in the accompanying illustration.

The greater part of the traffic on this line has heretofore been worked by Consolidation type locomotives. The new engines are similar to the Consolidations in several respects, but they

they can be safely used on spurs and branch lines. They operate on curves of 20 degrees. Three of them are equipped with train signal and steam heat, and can be used in passenger service if necessary.

The boiler is of the straight top type, with a wide firebox which contains a security sectional arch. The longitudinal seams have a strength equal to 90 per cent. of the solid plate. Two rows of Baldwin expansion stays support the front end of the crown, and 700 flexible bolts are installed in the breakage zone. The auxiliary dome is placed over an opening of sufficient size to enable a man to enter the boiler for inspection purposes. The throttle valve is of the latest Rushton design, with auxiliary drifting valve.

The machinery details include cast

they are required to do a considerable amount of backing and switching.

Further particulars are given in the following dimensions:

Gauge, 4 ft. 8½ ins.; cylinders, 20 x 24 ins.; valves, balanced slide.

Boiler—Type, straight; diameter, 68 ins.; thickness of sheets, 5/8 in.; working pressure, 200 lbs.; fuel, soft coal; staying, radial.

Fire Box—Material, steel; length, 96½ ins.; width, 66¼ ins.; depth, front, 69 ins.; back, 58¼ ins.; thickness of sheets, sides, 3/8 in.; back, 5/16 in.; crown, 3/8 in.; tube, 1/2 in.

Water Space—Front, 4 ins.; sides, 3½ ins.; back, 3½ ins.

Tubes—Diameter, 2 ins.; material, iron; thickness, No. 11 W. G.; number, 290; length, 18 ft. 2 ins.



2-8-2 TYPE LOCOMOTIVES FOR THE RARITAN RIVER RAILROAD.

E. W. Harrison, V.-P. and Chief Engineer.

Baldwin Locomotive Works, Builders.

present a great increase in steaming capacity in proportion to adhesion. The following table gives the leading dimensions of the two classes:

Type	Cylinders	Drivers	Steam Pressure	Grate Area	Total Heating Surface	Weight on Drivers	Weight, Total Engine	Tractive Force
Consolidation	20"x24"	51"	200	32.9	1,971	128,000	144,000	32,000
Mikado	20"x24"	51"	200	44.2	2,921	136,800	174,700	32,000

The two locomotives develop equal starting tractive forces, but the Mikado shows an increase in grate area of 34 per cent. and in total heating surface of 48 per cent., as compared with the Consolidation.

The main line of the Raritan River Railroad is laid with 80-pound rails, but the new locomotives are suitable for service on 60-pound rails, so that

steel piston heads, alligator type cross-heads with cast steel bodies, forked-end main rods, and Walschaerts valve motion.

The driving-wheel centers and boxes are of cast steel. Plain tires are used on the second and third pairs of driving-wheels. The rear truck is of the Hodges type, and the front and rear truck wheels are steel tired. The springs and spring rigging have been designed for severe service. The Mikado type wheel arrangement is especially suitable for these engines, as

Heating Surface—Firebox, 149 sq. ft.; tubes, 2,746 sq. ft.; firebrick tubes, 26 sq. ft.; total, 2,921 sq. ft.; grate area, 44.2 sq. ft.

Driving Wheels—Diameter, outside, 51 ins.; center, 44 ins.; journals, main, 9 x 9 ins.; others, 8 x 9 ins.

Engine Truck Wheels—Diameter, front, 30 ins.; journals, 5½ x 10 ins.; diameter, back, 36 ins.; journals, 6 x 11 ins.

Wheel Base—Driving, 13 ft. 8 ins.; rigid, 13 ft. 8 ins.; total engine, 29 ft.; total engine and tender, 60 ft. 11½ ins.

Weight—On driving wheels, 136,800 lbs.; on truck, front, 12,200 lbs.; back, 25,700 lbs.; total engine, 174,700 lbs.; total engine and tender, 310,000 lbs.

Tender—Wheels, number, 8; diameter, 33 ins.; journals, 5½ x 10 ins.; tank capacity, 7,000 gals.; fuel capacity, 12 tons; service, freight.

**Lehigh & Hudson River Railway.**

The Baldwin Locomotive Works has recently built for the Lehigh & Hudson River Railway four superheater Mikado type locomotives, which represent a considerable increase in capacity over the heaviest locomotives heretofore used on this road. These locomotives will be used in handling heavy freight and coal traffic. The line is laid with rails weighing 80 and 100 pounds per yard, and has grades of 50 feet per mile. The heaviest locomotives previously built for this road by the Baldwin Locomotive Works were of the Consolidation type, and their leading dimensions, compared with those of the new Mikados, are as follows:

Considering each square foot of superheating surface equivalent to 1½ square feet of water evaporating surface, the total equivalent heating surface of the Mikado type locomotives is 5,601 sq. ft. As compared with the Consolidation, the

Type	Cylinders	Drivers, Diam.	Steam Pressure	Grate Area
Consolidation . . .	22" x 28"	56"	200	75.6
Mikado . . . . .	25" x 30"	56"	190	100

air over the entire surface of the grate will be practically uniform. The grate work is firmly supported from the mud-ring and from one transverse cross-tie, there being no supporting studs in the fire-boxsheets. The furnace equipment includes a security arch, supported on six water tubes.

The longitudinal seams in the boiler barrel are welded at the ends, and have a strength equal to 90 per cent. of the solid plate. The dome is of pressed steel, 33 in. in diameter and 22 in. in height. The auxiliary dome is placed over a 15-in. opening in the shell, providing ready access to the interior of the boiler for purposes of inspection. The throttle valve is of the improved Rushton type, with drifting valve. The superheater is of the Schmidt type, with 38 elements and outside steam pipe connections.

The cylinders are built with heavy

Water Heating Surface	Super-heating Surface	Weight on Drivers	Weight, Total Engine	Tractive Force
2,864	964	160,000	180,000	41,200
4,155	964	212,700	285,400	54,000

firebox. The power reverse occupies but little room, which is a special advantage in the case of a cab arranged like this one.

The air-brake equipment includes one 9½-in. pump and one 8½-in. cross-compound pump. These are both placed on the left-hand side, just ahead of the fire-box and opposite the cylinder of the power reverse gear.

The following are the general dimensions of this type of locomotive:

Gauge, 4 ft. 8½ in.; cylinders, 25 in. x 30 in.; valves, piston, 12 in. diameter.

*Boiler.*—Type, Wootten straight; diameter, 82 in.; thickness of sheets, 13-16 in.; Working pressure, 190 lbs.; fuel, hard and soft coal mixed; staying, radial.

*Fire Box.*—Material, steel; length, 126½ in.; width, 114¼ in.; depth, front, 80 in.; depth, back, 65 in.; thickness of sheets, sides, ¾ in.; thickness of sheets, back, ¾ in.; thickness of sheets, crown, ¾ in.; thickness of sheets, tube, ½ in.

*Water Space.*—Front, 5 in.; sides, 4½ in.; back, 4½ in.

*Tubes.*—Diameter, 5½ in. and 2¼ in.;

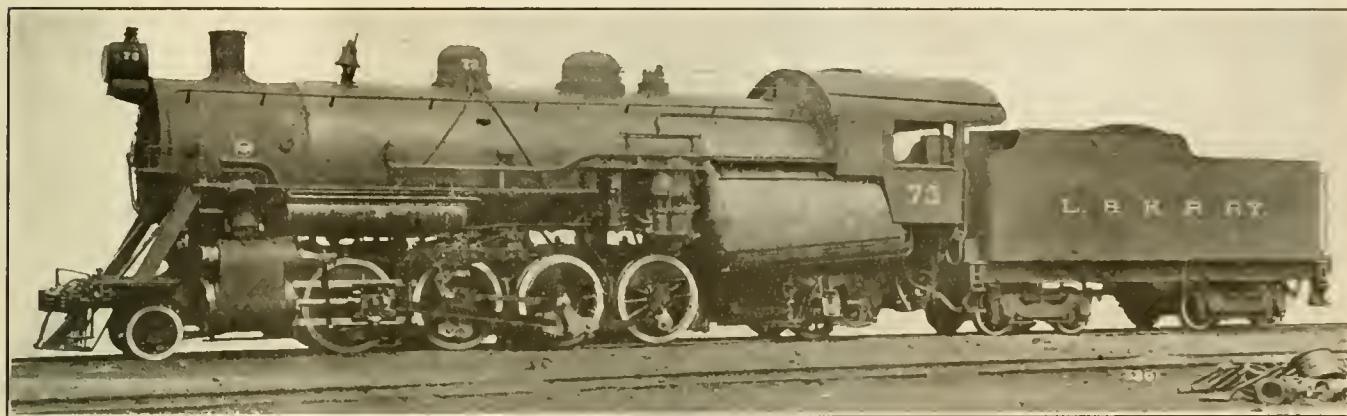

2-8-2 TYPE LOCOMOTIVES FOR THE LEHIGH & HUDSON RIVER RAILWAY.

R. T. Jaynes, Master Mechanic.

Baldwin Locomotive Works, Builders.

Mikado type shows an increase in tractive force of 31 per cent.; in grate area of 32 per cent., and in total equivalent heating surface of 95 per cent.

The boilers of the Mikado type locomotives are of the modified Wootten type, equipped to burn a mixture consisting of two-thirds fine anthracite and one-third bituminous coal. The boiler has a straight top, while the throat, back-head and roof of the firebox are sloping. Flexible staybolts are used exclusively in the water-legs, while the front end of the crown is supported on three rows of Baldwin expansion stays. There are two power-operated fire-doors, placed low down in the back-head. The grate is of a design which has proved specially satisfactory on this road. It is composed of rocking-bars, no drop-plates or water tubes being used. The bars rock in six sections, and are supported on two intermediate longitudinal bearers and two side bearers. Careful attention has been given to providing suitable draft openings in the rocking bars and bearers, so that the admission of

walls, so that they can be subsequently bored out and bushed if desired. Relief valves are fitted to the steam chests. The pistons are of the built-up type, with cast-steel heads and followers and cast-iron bull rings and packing rings. The bull rings are turned to a diameter 1-32 in. less than the bore of the cylinders. The valve motion is of the Walschaerts type, controlled by the Ragonnet power reverse gear.

This locomotive is cross equalized between the rear driving wheels and trailing truck by two horizontal transverse beams which are connected by a central vertical link. The pin holes in the spring rigging are bushed. The rear truck is of the Hodges type, with cast-steel frame. It is fitted with centering springs.

In this design the cab is placed at the rear end instead of over the middle of the boiler, as has heretofore been the practice with Wootten engines built for the Lehigh & Hudson River. The cab has a width of 10 ft. 9 in., and its sides are practically flush with the sides of the

material, 5½-in. steel, 2¼-in. iron; thickness, 5½-in. No. 9 W. G.; 2¼-in. No. 11 W. G.; number, 5½ in. 38, 2¼ in. 220; length, 21 ft. 0 in.

*Heating surface.*—Fire box, 251 sq. ft.; tubes, 3,855 sq. ft.; firebrick tubes, 49 sq. ft.; total, 4,155 sq. ft.; superheater, 964 sq. ft.; grate area, 100 sq. ft.

*Driving Wheels.*—Diameter, outside, 56 in.; diameter, center, 49 in.; journals, main, 11 in. x 12 in.; journals, others, 10 in. x 12 in.

*Engine Truck Wheels.*—Diameter, front, 30 in.; journals, 6 in. x 12 in.; diameter, back, 42 in.; journals, 8 in. x 14 in.

*Wheel Base.*—Driving, 16 ft. 6 in.; rigid, 16 ft. 6 in.; total engine, 35 ft. 0 in.; total engine and tender, 68 ft. 2½ in.

*Weight.*—On driving wheels, 212,700 lbs.; on truck, front, 23,200 lbs.; on truck, back, 49,500 lbs.; total engine, 285,400 lbs.; total engine and tender, about 450,000 lbs.

*Tender.*—Wheels, number, 8; wheels, diameter, 33 in.; journals, 5½ in. x 10 in.; tank capacity, 9,000 gals.; fuel capacity, 14 tons; service, freight.

# Important Development in Passenger Car Painting on the Pennsylvania Railroad

When the first all steel passenger car was built by the Pennsylvania Railroad Company at Altoona in 1906, an entirely new problem in painting was encountered.

car then receives a certain number of coats of varnish, sufficient to fill all voids remaining in the flat color and to leave a smooth, glossy coat of varnish over it.

terior of the car, judging from the artist's standpoint. In order to obtain the artistic finish for the interior of the car, it has been necessary to use surfacers, colors and varnish containing relatively large amounts of artificial driers and varnish gums. If these driers and gums are not used, the various coats supplied will not dry sufficiently hard to permit the necessary rubbing, and the gums are, also, necessary in order to obtain what we will call the "artistic" finish. On the exterior of the car it has been necessary to use the same artificial driers and gums, the only difference being that less gum was used in the final coats of varnish, as it has not been considered necessary to rub them for the purpose of removing the gloss.

The following difficulties have been encountered with this air dry system: In the first place, the artificial driers used for making the various coats dry in from one to two days time, continue their action indefinitely after the car goes into service, the paint and varnish becoming continually harder and more brittle, which renders them likely to be disintegrated by the rapid expansion and contraction of the steel over which they have been applied. It has been found in practice that in very many cases the interior

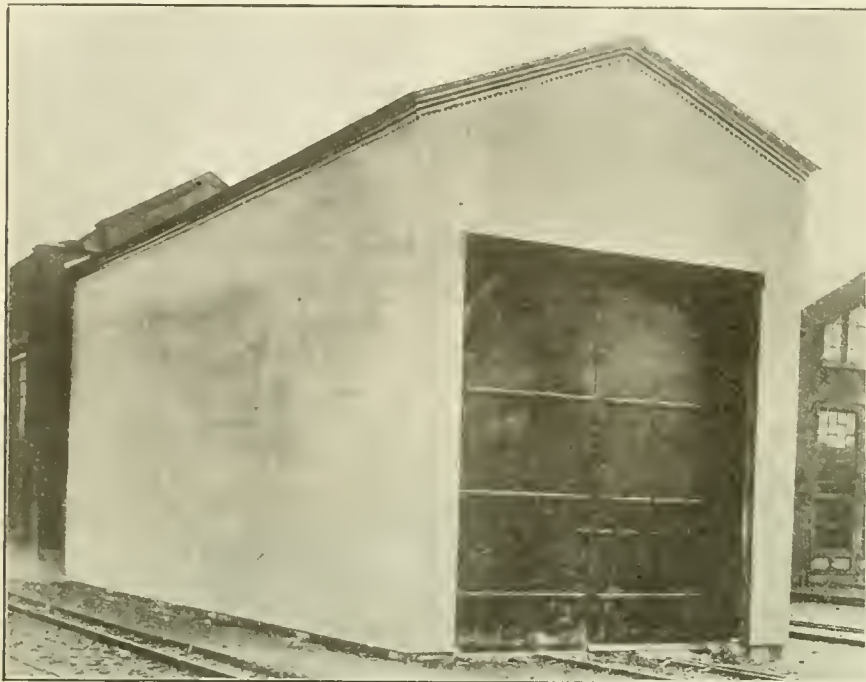

VIEW OF OVEN, CLOSED, WITH CAR INSIDE UNDERGOING THE BAKING PROCESS.

The expansion and contraction of steel, under the influence of fluctuations in temperature, is much greater than that of wood. For example, a piece of steel which is seventy feet long at 0 degree Fahrenheit would be something like seventy feet, one and eight-tenth inches at 100 degrees Fahrenheit. The expansion of wood under the same fluctuation in temperature would be less than half as great. Steel also conducts heat much more rapidly than wood, and sudden changes in temperature produce rapid expansions or contractions of the steel. It follows, therefore, that a painting system which would be satisfactory for wood, might not be sufficiently elastic for steel.

When the change in equipment from wood to steel was made, it was practically necessary to carry over the old system of painting and to apply the same principles on the steel car that had formerly been applied to wooden cars. It has always been the aim of the company to apply that painting system to the cars which would impart the best appearance to the finished car. The best appearance, based on the judgment of artists, has consisted in building up a surface on the interior and exterior of the car which could be rubbed perfectly smooth, after which the desired color is applied in what painters call a "flat" application. The exterior of the



VIEW OF OVEN, OPENED, AND PAINTED CAR ABOUT TO BE REMOVED.

The finish for the interior has been the same, except that it has been considered necessary to rub the final coat of varnish and give it a dull surface, a glossy finish being considered objectionable in the in-

terior of the cars has become badly checked or cracked after approximately four months of service, which certainly renders them inferior in appearance, considering the work from an artistic stand-



point. On the exterior of the car where it is possible to use a less amount of artificial drier, especially in the outside finishing varnish, the finished surface is often in a condition technically known as "tachy," which means that it is somewhat soft and that black dirt, such as carbon and soot from locomotives, adheres to it, soon rendering it more or less unsatisfactory, if critically inspected. We might say that it has been impossible to use elastic varnishes on the interior of the cars, for the reason that they do not dry sufficiently rapidly to be rubbed so as to give the desired appearance. It will be readily understood that a varnish having any "tachy" cannot be used in the interior, and even if it were not desired to rub the surface for the purpose of securing the proper artistic appearance, it would not do to use a material which would become more or less soft when passengers lean against the finished surface for a period of time and, perhaps, experiencing the same sensation that some of the readers of this may have encountered after sitting for a considerable period of time on certain varieties of church-pew varnishes.

In consideration of all of these conditions, a large number of experiments were made by the Chemical Laboratory, jointly with the Physical Testing Department and the master painters of the road, with the idea of coming to some method which might eliminate the criticisms enumerated. It was found that by baking a surface to which a coat of primer, surfacer, color or varnish has been applied, the use of artificial driers could be largely or entirely eliminated. The heated air dries these surfaces without the aid of artificial oxidizing materials and, as soon as the heat is removed, it would seem that the change of condition in the paint or varnish is immediately stopped, and the finished surface does not become more brittle as a result of the presence of objectionable constituents, which are necessary when the finished surface must be dried in cold air. It was also developed that by the use of this system the elastic varnishes, such as are used on the exterior of cars, could also be used on the interior, and by the aid of heat they could be dried sufficiently hard to be rubbed with oil and pumice stone for the purpose of removing objectionable gloss. It was also found that the exterior varnishes, which are more or less "tachy" when applied by the old process, could be sufficiently dried by the aid of heat to remove the "tachy," and thus render them in a condition to which black dirt, soot, etc., would not readily adhere. The exterior of a car could, therefore, be more readily preserved in its clean, glossy appearance, which it has when it leaves the paint shop, by the application of the baking process. After making hundreds of tests on small steel panels, it was decided to build an oven sufficiently large for any car, in

1912, and this first oven was completed in January, 1913. The first illustration shows one end of this oven closed with a car inside undergoing the baking process. The oven is 90 feet 3 inches long, and only half of it shows in the picture, as the other half extends into the shop. The second illustration shows the end of the same oven after it has been opened, and from which the car being painted is about to be removed. The third view shows the number plate on a car after two years and eight days' serv-



NUMBER PLATE ON CAR AFTER OVER TWO YEARS' SERVICE.

ice, and from this it will be seen that the gold figures with the black edges and the tuscan red body color are all in an excellent state of preservation. The last illustration shows an interior view of the same car after two years and eight days' service. This same car has now been in service for thirty-four months, and the condition is still nearly as good as represented by the illustration. In the course of two or three months the car will be returned to the shops for the purpose of having the color "touched up" where it has been abraded, after which it will be

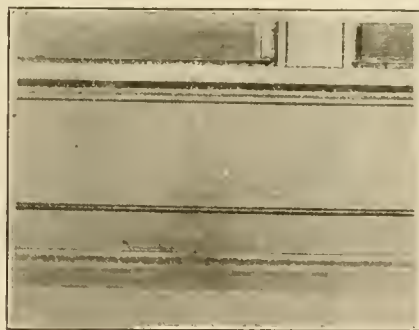

INTERIOR VIEW OF CAR AFTER MORE THAN TWO YEARS' SERVICE.

revarnished by the baking process for the first time since it was built, and returned to service. It might be said that this oven has been in continuous service since it was built, and no changes have been made on it except that some additional steam coil radiators were introduced, and a heat control device was also placed on the oven which can be set to automatically control the flow of steam to the radiating coils, and thus give any desired temperature which the painter

may wish to obtain. The oven is 15 feet high, 13 feet wide, both clearance measurements, and, as previously stated, its length is 93 feet 3 inches. It is lined with a  $\frac{1}{4}$ -inch steel shell. This is insulated with magnesia lagging 3 inches thick. The insulation is held in place by an outer jacket of galvanized iron. The doors are insulated with the same kind of lagging which is held in position by steel plates on the outer and inner sides. As the oven contains a large number of steam coils, and as the steam is used under pressure, it is possible to heat to any desired temperature up to 275 degrees Fahrenheit. The oven is equipped with ventilators on the sides at the bottom for the admission of air. It is also equipped with four ventilators in the roof, which can be opened or closed as desired. The ventilators enable the introduction of fresh air required in drying the various paint coats, and also allow the volatile portion of the coats used, the turpentine, for example, to escape through the roof. The composition of the different coatings used on the cars are the same as originally used on car 156 shown in the photographs.

The *modus operandi* of painting a car by this process is as follows:

The car is first painted inside and out with a priming coat. This is baked for about three hours at 250 degrees Fahrenheit. The primer is designed with reference to obtaining a product which will adhere very firmly to the metal and serve as a protective coating, which will prevent the steel from rusting, and which will also serve as a foundation on which to build the constituents entering into the surface coating. This is followed by necessary glazing and putty to fill all deep depressions and indentations in the steel used. A number of surface coatings are then applied, the number varying from one to perhaps four, the number depending on whether the steel used is very rough or relatively smooth. Each coat of material applied is baked. The car is then rubbed with emery cloth and oil for the purpose of securing a smooth, flat surface. The various colors desired on the car, such as tuscan red on the outside, apple green, bronze and dark green on the various parts of the inside of the car are then applied. Two coats of these are required to insure obtaining the solid standard colors desired. Each coating of color is also baked. The car then receives the necessary striping, lettering, etc., after which operation it receives two or three coats of high grade baking finishing varnish. After the varnish on the inside of the car has been rubbed to remove the gloss, previously referred to, the car is ready for service.

In this connection we might say that when the first oven was built, it was hoped that the following advantages, as

stated at that time, would result from the new system:

1. The durability of the various coatings is expected to be at least double that which is now being obtained by the air dry process.

2. The inside appearance of the car is expected to indicate for a long period of service a newness similar to that which it possesses when it first leaves the shop, and it is hoped that cracking of the varnish will be obviated, as a result of the use of exterior varnish, etc., for interior purposes.

3. It is expected that the outside of the car can readily be kept bright and clean, due to the fact that the black dirt and soot will not become imbedded in it.

4. The time of keeping a car in the shop for painting will be reduced from about sixteen days to about five to seven days. This will enable the company to obtain cars more quickly for rush holiday seasons, and, to a certain extent, obviate the necessity of crowding the passengers, due to not having a sufficient number of cars which can be taken out of the shops.

5. The number of cars in the shop at any one time should not be over one-half that which must be kept in at the present time.

The baking system has now been in use almost three years, insofar as it was possible with one oven. The five objects hoped for when the first oven was authorized have been attained. Two additional ovens are now being provided for, and it is probable that as soon as they have been put in service a still further extension of the system will be made.

#### The Tinkering Engineer.

A great change has come over the habits of engineers during late years, but it is not long ago since there were a great many locomotive engineers who seemed to think it was an evidence of proficiency to be constantly "doing work." They were always at the round-house and up to their ears in work. Not only did they pack cellars and boxes, doctor oil cups, clean headlight, and pack piston valve stems, and cab cocks, but they set up wedges, monkeyed with the side rods, lined up crossheads, etc., etc. Somehow they had got the idea that every point of the engine needed readjusting every trip; they never got through experimenting in the front end. They very often undertook to close up eccentric straps or file brasses, or do some other work delegated to machinists, and it was an insult to infer that perhaps the machinist could do it better; this class of men were always in trouble.

This is the man who had hot pins and break-downs, and had to open the front end on the road in order to get the chill off the water in the boiler.

The best engineers we ever knew were

men who took pains to key up their rods on the road when the engine was hot and in working condition and then left them alone; that got the front end so that the engine steamed well, and then kept out of it; that did not report work till they knew it was needed, and then insisted on its being done; that did not do machinists' work, and did not ask machinists to do theirs; men that could get a thing about right and then let it alone.

We recently went through a round-house with the general foreman in charge and as we passed an engine there arose from the pit a specter of grease, blue overclothes and perspiration that appalled us—it was the engineer. We passed on and the foreman said: "That man works night and day on his engine, and we do more work on her than on any of the rest; here is an engine run by a man whom I do not see once a month, never seems to do anything, but you can't find any brasses loose in his rod straps, his headlight is clean, his rod cups full. He does just what he is required to, does it well and lets it alone; he does all his work when he is laid out on the road or at the other end of the division. His home is here and he stays at home, and when he puts a report on the book you can depend that it is no case of imagination—it wants doing." There is a goodly lot of runners, with road experience only, who think they know more about repairing locomotives than machinists; there is a big batch of machinists, with shop experience only, who think they know more about running locomotives than engineers—both of them are very much mistaken.

If you are a machinist, try to be the best one the company has got; handle the engines when they are cold and let the engineers handle them while they are hot.

If you are an engineer, be a careful, sober, everyday man and an expert runner, and when you get in go home and to bed, and let some experienced machinist actually take down the rods and file brasses on your pet engine, thinking that perhaps he will do it just as well as you would yourself.

#### The Rat Catcher's Death.

The *Great Western Railway Magazine* (London) records in an issue just at hand the death of its official rat-catcher, H. J. Branfield. If there is an official, or any other kind of a rat-catcher in the employ of an American railroad, he has escaped our notice. Nevertheless this is not saying that rat-catchers are not needed. Contrary to imagination, Mr. Branfield is a very aristocratic appearing man, judging from the portrait published; in fact, he would pass for a banker on Broadway. In regard to his work the English magazine writes entertainingly:

"For upwards of 40 years Mr. Branfield's family has been intrusted with the

responsibility for the suppression of rats on the Great Western Company's premises, where considerable damage might be caused to such traffic as grain when warehoused. Mr. Branfield's methods of procedure were the result of long experience and varied according to the circumstances. Difficulties in trapping rats are great, especially when there is abundance of foodstuffs, and where, as often happens, raids are made from the surrounding banks and fields. He made a practice of personally visiting the stations where his services were required in order to ascertain the best method of clearing the premises. During his career he had many extraordinary experiences, and one may be recorded. Poison was to a large extent used by him, but he endeavored to take the rats alive where possible.

"Some years ago, after clearing one of the Shropshire warehouses and securing over 90 live rats, which he imprisoned in a cage, he and his assistant, after a heavy day's work, were traveling home by train in the early days of corridor coaches. They had a compartment to themselves, and in order to relieve the pressure in the cage about 20 of the rats were transferred to a sack. Mr. Branfield and his assistant happened to fall asleep, but were aroused by the rats, which had eaten a hole in the sack and were running about the compartment, one being actually up Mr. Branfield's sleeve! Fortunately the corridor door was closed. If the rats had managed to invade the other compartments in the train the consequences might have been more than humorous."

#### Kiss Me Twice.

Little Dorothy was being taken on a railroad journey by her aunt and aunty's fiancé. In a darksome tunnel was heard the smack of a kiss and the voice of Dorothy.

"Oh, aunty," she exclaimed, "please kiss me, too!"

Before the smiles of the passengers could break into titters she calmly addressed the child:

"It is incorrect to say 'Kiss me, too,' Dorothy dear," said aunty. "You should say 'Kiss me twice!'"

An Englishman, Irishman and Scotchman made an agreement among themselves that whoever died first should have five pounds placed on his coffin by each of the others. The Irishman was the first to die. Shortly afterwards the Scotchman met the Englishman and asked him if he had fulfilled the agreement.

"Yes," said the Englishman, "I put on five sovereigns. What did you put on?"

"Oh, I jist wrote ma cheque for ten pounds," said the Scotchman, "an' took your five sovereigns as change."

# Air Brake Department

## Repairing Air Compressors—Triple Valve Lubrication

From certain observations we are inclined to think that practically every air brake repairman has some hobby in connection with the repair work on some particular piece of air brake apparatus, and it might be well if every repairman's hobby was on the repair work done on the air cylinder of the air compressor. This for the reason that about 85 per cent. of the repair work necessary to be done on the air valve parts of the locomotive

the pump or compressor will not be too good.

If an air pump is defective in the air cylinder it may be expected to run hot and scatter quite an amount of partially burned oil and gummy substance throughout the entire brake system of the locomotive and to result in the carrying of a great deal of water from the main reservoirs into the brake pipe of trains of cars and in order to avoid this so far as pos-

of 100 single strokes per minute. The New York Air Brake Co.'s 6A and 5B compressors must maintain the same number of pounds air pressure with 100 single strokes of the piston per minute against 13/64 and 15/64 circular openings, respectively.

This in itself is not an exacting or a severe test for a repaired compressor or one that is in good condition, the most difficult part of the requirements are con-

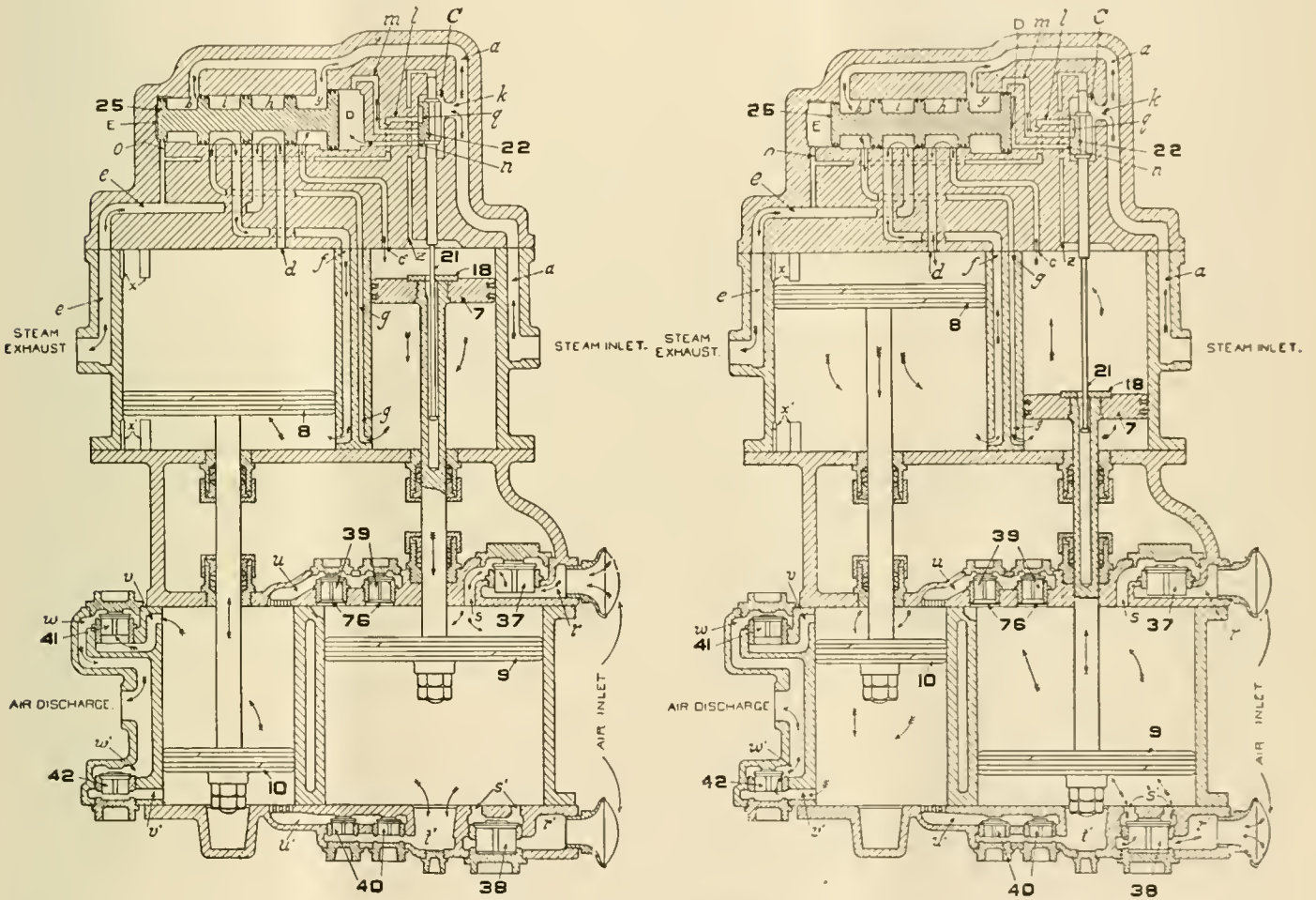

SECTION VIEW OF AIR COMPRESSOR, SHOWING UP AND DOWN STROKE.

brake is directly traceable to the condition of the air cylinder of the compressor, or it is at the air cylinder that the air brake work usually begins. Fitting up an air pump for a locomotive handling modern trains of freight and passenger cars is a vastly different proposition from that existing 8 or 10 years ago, for the reason that requirements in service are not only more rigid, but a compressor must pass a certain test on the shop rack and from the present time on must be in a condition to at all times pass a test prescribed by law; therefore the best workmanship that can be done on

sible the air cylinder of the compressor must be in the best possible condition that it can be maintained in.

In order to comply with the law a 9/2-inch air pump must be in a condition to maintain air pressure at 60 pounds per square inch, against a 11/64-inch circular opening to the atmosphere when running at a rate of 60 cycles per minute and the 11-inch compressor must maintain this pressure against a 3/16-inch circular opening with 50 cycles or 100 strokes per minute, and the Cross compound compressor must maintain this pressure against a 9/32-inch opening when working at a rate

stantly maintaining the compressors in a condition to pass this test, which means that the compressor must be overhauled in a manner that will insure this performance during the entire life of the pump or between periods of repairing. In order to accomplish the desired results, an accurate fit of parts is absolutely necessary, especially in the air cylinders, and in the following we wish to outline a method of repair work which, if followed, will insure an efficient compressor.

Some years ago we were inclined to consider, first, the fit of the air piston on the rod; but, as a heavy taper fit for these

parts is now the standard for all sizes and types of air compressors, drawing up the piston rod nuts will insure a tight fit of the head or air piston on the rod. The first consideration in repairing the air end of the compressor is a straight, round cylinder, a perfect fit of piston rings cannot be obtained in a worn cylinder, and to attempt it is only a waste of time and material.

The air piston of an overhauled compressor should fit the cylinder, not be 1/32 or more smaller than the bore of the cylinder, while the cylinder is rebored or the piston turned to fit it, a perfect fit can be made without incurring any additional expense, and this should be insisted upon as a neat fitting air piston compels the entrance of a fixed volume of free air to the cylinder during operation, regardless as to the temperature of the compressor up to the time the air cylinder is approaching a red heat. Another important point is the fit and lift of the air valves, the lift of valves should not be over 5/64 of an inch when fitted, so that by the time they are worn to a perfect bearing on the seats the lift will not be in excess of the standard 3/32 of an inch. A very economical practice in connection with fitting air valves, when shop facilities are such that it can be correctly done, is to bush the air valve cages with a piece of steel tubing which forms the interior and seat for the valve. By this method the inside diameter of the valve cage may be made a trifle less than that of the standard valve and the seat may be left a trifle higher, so that a considerable number of otherwise worn-out air valves may be used and have the required lift and fit in the cage.

Accurately fitting the piston rings or packing rings requires certain mechanical ability and very good judgment, first the ring must fit the piston groove and have a bearing in the groove, then it should fit the wall of the cylinder or have a bearing all the way around in the cylinder, regardless as to how the fit is obtained whether by springing the ring or filing or scraping it, and the ends must be filed squarely to make an airtight joint at the ends. When finished they should lap over at the ends, the amount of permissible lap depending upon the fit of the ring in the groove, but in all cases they should lap over enough to make a driving fit when the piston and rings are entered in the cylinder. This will compensate for slight mistakes in the actual bearing of the rings against the wall of the cylinder when fitting them, and to make a hard driving fit without taking chances of sticking the rings in the groovers requires some experience and good judgment; however, the sticking of rings in the groove is more frequently or likely to be caused by corrosion while the pump is not in use for a period of weeks with the

engine in the shop, rather than by the fitting of the rings in the cylinder.

The steam cylinder of the compressor, as a general proposition, is not given as careful attention as the air cylinder, and it is not absolutely necessary and a great many second-hand piston rings can be utilized in the steam cylinder, but fairly accurate work should be done on the direct acting pumps, and the cylinders should be rebored if out of true over 1/64 of an inch. A trifle more than this is sometimes permissible in the 11-inch cylinders, but the workmanship on the steam portion should be accurate enough for the compressor to pass an efficiency test of the steam cylinder, and the following table will give a very fair test:

Steam Pressure.	9½	11	8½
100 "	145	110	70
120 "	165	130	90
140 "	180	150	130
160 "	190	170	150
180 "	200	180	170
200 "	210	190	175

At the steam pressures given, each compressor should make approximately the number of single strokes per minute shown in the table when the escape from the main reservoir is regulated to maintain the air pressure operated against at 60 pounds, if the steam valve mechanism and the steam cylinder are properly fitted. This is for a one-inch steam supply for the 9½-inch compressor, and a 1¼-inch steam pipe for the 11-inch and 8½-inch compressors.

The critical or acid test for the steam portion of any air compressor is when the compressor is working against the maximum air pressure employed in service with a steam pressure about 15 or 20 per cent. below the maximum carried, but these pressures are variable and the performance of the compressor under the severe conditions are subject to observation every day at the daily inspection of the locomotive brake apparatus.

The above applies very forcibly to the steam portion of the 8½-inch cross compound compressor, and for the reason that all of the work done in the low pressure steam cylinder is by the exhaust steam from the high pressure steam cylinder, and there is no by-pass arrangement whereby any live steam may be admitted to the low pressure cylinder except by leakage, which interferes with, and slows up, the speed of the compressor pistons. With a correctly maintained steam portion this compressor will maintain 140 pounds air pressure under average passenger train conditions with 160 pounds steam pressure, but with a poor condition of the steam cylinders it is a difficult matter to maintain this air pressure with 190 or 200 pounds steam pressure, in fact when the steam cylinders are appreciably worn and the rings poorly fitted the speed of the compressor reduces very materially when the air pressure rises above 100

pounds. This is probably the most important part of the repair work on this type of compressor.

In repairing these compressors the piston rings should be fitted as previously outlined, and if efficiency is desired the cylinders must be true, and through the compounding arrangement the wear of the cylinders is much less than with the single-acting pumps. We have no desire to exploit any particular type of air compressor, but in view of the objections offered to the use of the cross compound, particularly by those who have had no experience with it, it might be of interest to point out that the writer, during the past three years, has never seen but two broken-down cross compound compressors—one in which a workman failed to put a cotter key through the main piston valve bolt, and the nuts worked loose and the piston valve separated; in the other case the compressor had been in service for such a length of time that the piston rings at the small end of the main valve were worn down to the thickness of a piece of cardboard and the rings were broken. Broken main piston rods were of frequent occurrence some years ago when the air piston was fitted on the rod with the straight shoulder fit, but the writer has never seen a broken piston rod of the taper-fit variety. There are records of failures due to broken upper steam cylinder gaskets, and in repairing the compressors broken gaskets are sometimes found, but we have never found one to be the cause of a failure.

There is, however, a question as to whether the most important part of the repair work is the fitting up of the steam portion or the fitting up of the air valves, for when the valves have somewhat more than 3/32-inch lift, they result in a pounding of the compressor with the result that the heavy compressor pistons soon pound the bracket loose on the boiler and break off the studs in the boiler, therefore the importance of starting the valves with a trifle less than the standard lift specified by the manufacturers.

The greatest trouble experienced with the compressor is from the sticking of air valves, due to the use of an excessive amount of superheated valve oil in the air cylinders; this, however, is a matter entirely outside of the subject, as the practice cannot be traced to any fault of the compressor, the trouble may be corrected by washing out the air cylinders by running lye water through them.

With the correct lift the oil-tempered air valves do not break in service, but there is a disorder in the low pressure air cylinder which, if not corrected, will at times manifest the action of a broken or stuck open intermediate air valve. This occurs after the low pressure air piston rings are worn out and too loose in the cylinder, then if a small quantity of oil is admitted to the cylinder only about one-

half of it may be lubricated and if the other half is dry the introduction of oil will tend to permit the compressed air to get between the rings and the cylinder at the dry portion and force the dry part away to such an extent that all of the air being compressed passes the rings and gives the action of the compressor the appearance of a broken intermediate valve. To give the cylinder an excessive amount of oil will give a temporary relief, but the same trouble will recur, so that the correct remedy is to make the necessary repairs. This is not so likely to occur in the high pressure air cylinder, as the piston and rings are much smaller and there is compressed air pressure on both sides of the piston when the compressor is in operation. As an example of the difference, this action of the loose rings is frequently encountered in the 11-inch pump, but rarely if ever in the 9½-inch pump.

#### Triple Valve Lubrication.

In a previous issue it was mentioned that the fit of a triple valve piston in its bushing was of importance to the operation of the valve, in fact it is the most important observation to be made in connection with triple valve repairs, and such statements in themselves must be qualified as the different parts of a brake system are so closely related in their action, and an undesirable effect may have a cause at some very remote point or an effect may be produced by a number of causes and in mentioning the fit of the triple valve piston as a point for improvement in triple valve operation we would not neglect the lubrication as a factor in undesired operation.

Some years ago the Master Car Builders' Association authorized a test of a large number of triple valves, one portion to be lubricated with oil, another with dry graphite and the other with no lubricant whatever, the valves were placed in the same class of service and about the same results were obtained from all of them; the tests were, however, made under moderate temperature conditions, rendering them of very little practical value.

The development of certain features in brake equipment calls for laboratory tests and all tests can be properly made, but when it comes to lubricant the tests must be made under the most adverse conditions if they are to be of any real value. An illustration occurs to the writer, in witnessing a test of triple valve lubricant in which dry graphite versus light bodied oil was to be tested. After 1,000 applications the valves were to be taken to the test rack and results noted.

About the only difficulty with the test was that the compressed air to the triple valve was supplied direct from a very busy and much overheated 8-inch air pump, and quite naturally every valve removed and taken to the rack after the thousand applications had developed into

a "dynamiter," so the decision was that the graphite was no improvement over the oil, and under the conditions it certainly was not.

If a triple valve is correctly fitted, the lubricant problem is insignificant for a short space of time, but any moist lubricant is sure to pick up any foreign matter that may be passing through the valve, and any moist lubricant is merely a dirt collector and when it is used in the packing ring groove or in the piston bushing of a triple valve it tends to assist in "packing" the ring to the further exclusion of leakage that would otherwise occur, but when this lubricant is blown away or absorbed by a collection of foreign matter in service, the maximum amount of ring leakage will be encountered, and the repairman using the oil or grease has only deceived the test rack operator and probably himself also.

After a considerable amount of experience with dirty triple valves, stuck brakes and undesired quick-action, the writer has arrived at the conclusion that the only proper lubricant for any part of the triple valve, slide valves, pistons and rings of the control valves and universal valves and the equalizing portion of a distributing valve is dry graphite, and in the absence of this no lubricant whatever should be used. This will, of course, be disputed by the man who favors oiling them up, or who is willing to compromise on something, but so long as moisture or any moist lubricant is present on the slide valves or in the piston bushing of a triple valve undesired quick action is going to occur at an unexpected time, and while the writer has repeatedly listened to stories of how this disorder has been entirely overcome, and in fact at several different times persuaded himself that he had definitely overcome it, he now wishes to state that this disorder will not be entirely eliminated so long as there is a brake pipe venting device attached to a car brake operating valve, and the margin between the rate of brake pipe reduction that produces service operation and that which must produce quick action is no greater than the present specified by the Master Car Builders' recommendations. Further than this, the greater the amount of moist lubricant used on these valves, the more frequently the disorder can be expected to manifest itself, and the longer the period of time the valves can be maintained dry, the less the chances are for the disorder to occur.

We are not particularly concerned with convincing anyone that this is right, as even the air brake companies recommend oil for the piston ring and bushing, but when it comes to stopping an actual case of a distributing valve working in undesired quick action the writer and several hundred air brake repairmen have the steady habit of wiping the equalizing portion of that valve dry, and assuming that

no mechanical defect is found there will be no more undesired quick action until someone again oils it or oil works into it from some outside source. The same may be said of the triple valve. We have never found a triple valve working in quick action with a service rate of reduction as long as it was found dry, except when the dryness was accompanied by some serious mechanical defect.

This moist lubricant refers particularly to the piston bushing, as the use of dry graphite for the slide valves is now almost universal, and the oil that is used on the ring first helps the ring to pass the packing ring leakage test, then the oil collects a certain amount of foreign substance which destroys the "packing," permitting the full amount of possible ring leakage and at the same time forms a grinding compound in the bushing that frequently gives just enough resistance to the movement of the triple valve piston to cause it to jump to emergency position when it is dislodged. If the piston remains dry, this foreign substance will not be collected and the point that should be brought out is, that when one triple valve goes the required distance without any trouble and another in the same service does not, there must be something radically wrong with the valve that fails. And in connection with this the most serious mistake made is to put up a triple valve with enough internal resistance to movement that will require lubricant for it to successfully pass the tests on the rack, so that when the lubricant has disappeared the valve is naturally defective.

As a guide for correct repair and maintenance methods for car brake operating valves, we would suggest, first, a triple valve so accurately fitted that it will pass the test dry, and that it thereafter be maintained dry. The valve can be thoroughly dried during the cleansing process and lubricated throughout with dry graphite, and the most serious objection to the use of dry graphite in the piston bush is that it requires a more accurate mechanical job for it to pass the test than when oil or grease is used, but this is really the strongest argument in favor of its use. Before applying a triple valve the dirt collector should be cleaned and before making the connection to the triple valve the collector and brake pipe should be blown out with compressed air and the amount of lubricant used in the brake cylinder should be confined to from 4 to 6 ounces, so there will be no possibility of any of it working back into the triple valve; then, if the air from the yard plant is dry, the repairmen have done their part in the effort to remedy cases of stuck brakes, slid flat wheels and undesired quick action. The foreign matter that may thereafter enter the brake system from the air cylinder of the compressor through overheating or through incorrect main reservoir piping arrangements is an-

other distinct phase of air brake maintenance that will be referred to at a later date.

If the reader has any doubts concerning the effects of moist lubricant and poorly fitted triple valve pistons, he may make a series of tests, not under test rack conditions or normal temperatures, but under service conditions and low temperatures, as the defective triple valve removed early in the morning frequently passes a satisfactory test after it has been in the shop for several hours.

Just why anyone will recommend oil or grease for triple valve lubrication is, to the writer, an ever-increasing mystery for the reason that we first know that dirt and foreign matter will pass into and through the triple valve, regardless as to the efficiency of the dirt collectors; if this were not so, it would never be necessary to clean a triple valve. This foreign matter will then be collected by the oil and quickly destroy any lubricating properties the oil may have had and leave the piston bushing and ring in a worse condition than if it had been left dry in the first place, and this in itself is about the most annoying trouble that is now found in car brake operating valves. Under certain methods of inspection and test it may not be of much consequence, but if a brake test truck is in use or some device that will show the differential of pressure required to affect movements of the valves is employed, and a limit is fixed upon the difference in brake pipe and car reservoir pressure that *must* produce a movement to release the brakes, it will be found that oil as a lubricant is at the bottom of most, if not practically all, of the car brake operating valve trouble, assuming, of course, that standard test racks are in use.

While it may not be possible to prevent foreign matter from passing into the triple valves, it is possible to prevent the collection of the dust and gritty substance in the triple valve piston bushing by the use of dry graphite as a lubricant; however, air brake men will tolerate the use of oil and grease in triple valves, but from the amount of damage to equipment that can be traced directly to this, and the constant enlargement of the scope of Federal Regulations, it is reasonably certain that the application of moist substance to car brake operating valves in interstate traffic will eventually be discontinued.

#### Mr. S. W. Dudley Before the New York Railroad Club Meeting.

Mr. S. W. Dudley, Chief Engineer of the Westinghouse Air Brake Company, has contributed another technical addition to air brake literature in the form of a paper on the subject of "Recent Developments in Brake Engineering and Practice," which he recently read before a meeting of the New York Railroad Club.

Mr. Dudley is known to most of our readers as the right hand man of the great air brake engineer, W. V. Turner, in fact Mr. Dudley is Mr. Turner's successor to the position of Chief Engineer of the Westinghouse Air Brake Company, and has already done a very full share in the advancement in the air brake art.

Our readers will further understand that the papers usually read before the Railway Club meetings are of such a volume and character that they are bound in book form for future reference and study for the members, and in its length and from the information contained therein, this paper is no exception, therefore a very brief resumé is all that it will be possible to print at this time.

Mr. Dudley states that the most notable accomplishments in the field of brake engineering during the past few years have been, not the many ingenious devices developed, but the establishment and exposition of fundamental principles, resulting in a better appreciation and utilization of the possibilities of brake apparatus for increasing the convenience, economy and safety of modern passenger traffic, and points out that the word brake no longer symbolizes merely a triple valve and certain other apparatus required to bring a brake shoe in contact with the wheels of vehicles, but that the presentation of facts, backed by performance, has demonstrated that the brake is a complete system of highly specialized and effective units, without the aid of which the transportation of passengers and freight as we know it today would be impossible.

He then sets forth the manner in which the above has been demonstrated, showing the effects of increased car weight and improved brake apparatus on the length of the emergency train stop distance, and sums up all of the facts entering into a train stop, giving formulas from which the factors and train stop distances may be calculated.

The paper also illustrates the work done in stopping a train of cars and the mechanism now available for doing this work, and an enormous amount of air brake information is contained in the diagrams used in indicating the performance of the different types of brakes. Naturally the performance of the electro-pneumatic brake is touched upon, but it is a noteworthy fact that the paper deals less with type of brake equipment than the performance of brake shoes and the efficiency of the foundation brake gear, as Mr. Dudley takes the stand that an efficient foundation brake rigging is one of the vital factors in a perfect brake and that it can by neglect become one of the chief sources of improper brake action, loss and danger, but if given proper consideration in the design, installation and maintenance, it can be made not only highly efficient in the performance of its specific function, but also contributes to

greatly improved brake shoe, wheel, journal and pedestal conditions.

From the manner in which the brake shoe and brake gear subjects are handled in this paper, and from air brake information in general that may be derived from the study of it, we trust that the Westinghouse Air Brake Company may see fit to make reprints of it, for it should be studied by every railroad man who is able to exert any influence tending to the betterment of air brake conditions.

#### Antiquity of Passports.

Passports are a very ancient institution. Some of the old monkish chroniclers mention as an achievement on the part of King Canute that he obtained free passes for his subjects through various continental countries on their pilgrimages to the shrines of the Apostles Peter and Paul, at Rome. Each pilgrim was furnished with a document in the nature of a passport called "Tructuria de Itinere Peraganta." Hall in his "Chronicle" makes reference to a system of passports in the time of Edward IV, and the enforcement of this system is known to have been very strict in the reigns of Elizabeth and James I.

#### Induction and Deduction.

In scientific studies the mind rises from the contemplation of facts to the principles on which they depend. This passage from facts to principles is called induction, which in its highest form is inspiration; but to make it sure, the inward sight must be shown to be in accordance with outward fact. To prove or disprove the induction, we must resort to deduction and experiment. All valuable discoveries have been proved in this manner.

#### Boston Again.

A New Yorker, who recently returned from a visit to Boston, vouches for the truth of the following: One afternoon he found the six-year-old son of his host settled in front of the drawing-room fire with a sheet of paper before him and a pencil clasped in his chubby fist. Stealing a look over the boy's shoulder, he saw that the little fellow was making pictures.

"Well, Bobby," he asked genially, "are you drawing an engine?"

Slowly the child looked up and slowly he spoke:

"It would take a very strong boy to draw an engine; but I am making a picture of a locomotive."—*Youth's Companion*.

#### American Railway Association.

The next meeting of the American Railway Association will be held at the Biltmore Hotel, New York, on May 11. Mr. J. F. Fairbanks, secretary, 75 Church street, New York.

# Electrical Department

## The Electric Locomotive—Electric-Driven Trolley Track

Electric locomotives have already reached a high degree of development, and present practice shows a primary division into two groups, namely, those in which the axles are driven independently, and those in which they are coupled and driven collectively. With a few exceptions these two groups correspond with the continuous-current and the alternating-current systems of operation respectively, and have their origin in limitations of motor design. With the exception of the Pennsylvania Railroad locomotives, all important side-rod locomotives have been designed for alternating-current systems. With the exception of the Norfolk and Western locomotives, all driving through jack shafts have been designed to use single-phase commutator motors; with the exception of the later Löttschberg locomotives, all driving through Scotch yokes use polyphase motors. Two methods are used for driving the axles independently, namely, the geared and the gearless. Unless the driving is effected through a spring-supported quill, both methods add to the dead weight carried by the axle, and the additional weight is of interest from its bearing on the maintenance of the parts. Collective driving through side rods assumes several forms, but all result in considerable strains in the structure. Where the locomotive is driven by motors of uniform torque the main driving forces cause alternating stresses of low frequency in the structure, but where the driving torque is impulsive the resultant frequency becomes comparable with the natural frequencies of vibration of some of the parts, and at certain speeds destructive vibrations are liable to be set up from resonance between the frequency of the main driving torque and the natural frequency of vibration of some part or parts. Vibrations of smaller intensity and varying with the adjustment arise from indeterminateness in the application of the driving forces, and such vibrations are also met with in steam locomotives. The polyphase locomotive from its constant speed characteristics is less likely to be affected with vibration troubles than others.

The classification of locomotives according to wheel arrangement has been adopted from steam practice, but hardly affords the same insight as to the type as in the case of the steam locomotive. Electric locomotives have not always been designed with due regard to the question of stability of the rolling motion of the wheels, and some run less smoothly than is desirable on this account. The tilting of the rails and the coning of the wheels cause the progression by pure rolling to

assume a sinuous nature, and on the stability or instability of this motion depends whether the nosing effect tends to die down or to increase to the limits permitted by the wheel flanges. It can readily be shown that a locomotive carried on a rigid wheel base is in some circumstances unstable, and may accordingly be expected to develop a nosing tendency if run at high speed; the same is true when the locomotive is divided into units each carried on a rigid wheel base; guiding wheels elastically centered to align with the main wheels tend, however, to stabilize the motion.

There are few available records of

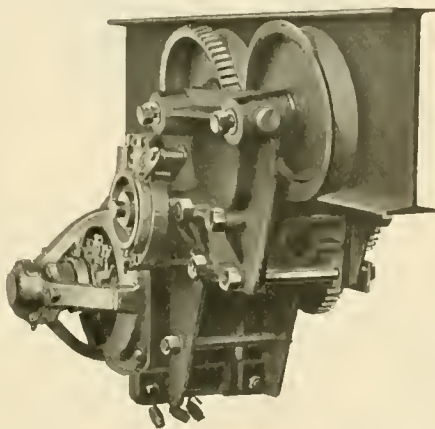

CAST STEEL TROLLEY TRACK.

tractive-resistance tests on locomotive-drawn electric trains, but among the most complete are those taken by the General Electric Company in connection with the endurance test on the first New York Central and Hudson River Railroad locomotives. These were made on trains of two different types of passenger vehicle, and are of importance in showing very conclusively that, for a particular type of coach, the additional tractive resistance per additional coach is a function of the speed and is independent of the number of coaches, provided this is greater than two. The additional tractive resistance per additional coach was found to be a straight line function of the speed within the limits of the tests. The effective locomotive resistance when running with a train was found to be smaller than that of the locomotive running alone.

### Electric-Driven Trolley Truck.

A great saving has been made in railroad machine shops by the use of the overhead or tramrail system of handling all kinds of material in both large and small installations. The Brown Hoisting Machinery Company, Cleveland, Ohio, have been successfully building these sys-

tems for many years, and have recently made important improvements that are coming rapidly into popular favor. In the monorail man-trolley, which is used for transporting materials from and to cars, boats, storage yards and buildings and the different floors of buildings, the appliance travels on the lower flange of an I-beam track, and is operated by one man, who rides in the trolley cab, and reaches the different points in the yards and building by the use of switches, turntables and transfer cranes in connection with the I-beam tracks. It can readily be equipped with grab bucket or with one, two or four hooks. It consists of a built-up steel frame, carrying the mechanism for hoisting and lowering the load, together with the motors, electric equipment and cab for the operator. The frame is suspended from two trolley trucks, each equipped with four high-carbon steel wheels, which travel on the I-beam track. The trucks are of cast-steel, and are so constructed that the planes of the truck wheels are perpendicular to the flanges of the I-beam in which they tread, as shown in the accompanying illustration of one of the four trucks. This makes the trolley easy running and results in less wear on the truck wheels.

Two of the wheels on each truck are connected to a travel motor for propelling the trolley along the track. The use of a travel motor on each truck gives the best trolley operation, and are generally made with variable hoisting and traveling speeds. The trolley truck is fitted with current collectors, which take the current from wires or conductor bars strung along the I-beam. The rating is so many foot-tons per hour. For example, a 3-ton trolley with a 2,400 foot-tons per hour rating, will hoist and lower 3 tons 10 feet, 80 times per hour continuously day and night. This rating may be doubled for periods of half an hour or more. For operating on curves, the trucks are of the swivel type, allowing the trolley to operate on curves with small radii. The materials are all of the best, and every contingency has been provided for.

### Roller-Smith Company's Volt-Am-meters.

The "Portable Standard" volt-ammeter was designed with the particular requirements of signal engineers and supervisors in mind, and in addition it has found favor for laboratory testing where high accuracy is required. The various ranges which are incorporated provide means for the great variety of tests which have to be made. For direct current signal systems it has no equal.

# Items of Personal Interest

Mr. Fred C. Ruggles has been appointed roundhouse foreman of the Rock Island, with office at Burr Oak, Ill.

Mr. F. P. Pfahler has been appointed motive power inspector of the Baltimore & Ohio, with office at Baltimore, Md.

Mr. G. K. Galloway has been appointed assistant master mechanic of the Baltimore & Ohio, with office at Glenwood, Pa.

Mr. P. L. Drescher has been appointed master mechanic of the Evansville & Indianapolis, with office at Terre Haute, Ind.

Mr. H. E. Bennett has been appointed superintendent of shops of the Chicago, Terre Haute & Southeastern at Bedford, Ind.

Mr. William Henry, formerly master mechanic of the Frisco System at Neodosha, Kan., has been transferred to Fort Smith, Ark.

Mr. R. C. Hyde, formerly master mechanic of the Chicago, Rock Island & Pacific at Manly, Iowa, has been transferred to Valley Junction, Ia.

Mr. E. S. Pearce has been appointed assistant mechanical engineer of the Cleveland, Cincinnati, Chicago & St. Louis, with office at Beech Grove, Ind.

Mr. M. A. Peers has been appointed district master mechanic, District No. 2, Saskatchewan division of the Canadian Pacific, succeeding Mr. J. Neill.

Mr. R. C. Harding has been appointed bonus supervisor of the Gulf, Colorado & Santa Fe, with office at Cleburne, Tex., succeeding Mr. J. M. Devlin, resigned.

Mr. Guy Pinner has been appointed bridge engineer of the Seaboard Air Line, with headquarters at Norfolk, Va., succeeding Mr. W. O. Scheurman, resigned.

Mr. J. J. Wenzel, formerly assistant roundhouse foreman of the New York Central at Air Line Junction, O., has been appointed erecting foreman at Elkhart, Ind.

Mr. J. Stackhouse has been appointed superintendent of materials and supplies of the Philadelphia & Reading, with office at Reading, Pa., succeeding Mr. J. K. Witman, deceased.

Mr. E. A. Pettit has been appointed general foreman of the locomotive shops of the New York Central, with office at Elkhart, Ind., succeeding Mr. H. E. Warner, promoted.

Mr. Oscar Culbreth has been appointed road foreman of engines for the entire Cairo division of the Cleveland, Cincinnati, Chicago & St. Louis, with headquarters at Mt. Carmel, Ill.

Mr. M. D. Franey, formerly master mechanic of the New York Central at Elkhart, Ind., has resigned to take a position

with the American Brake Shoe & Foundry Company at Erie, Pa.

Mr. B. Edison, formerly road foreman of locomotives of the Grand Trunk at Smithers, B. C., has been appointed road foreman of locomotives of the same road, with office at Regina, Sask.

Mr. George W. Armstrong, formerly assistant shop superintendent of the Erie at Susquehanna, Pa., has been appointed superintendent of the central manufacturing plant at Meadville, Pa.

Mr. W. B. Embury has been appointed master mechanic of the Indian Territory division of the Chicago, Rock Island & Pacific, with headquarters at Shawnee, Okla., succeeding Mr. W. J. O'Neill, promoted.

Mr. P. C. Moshisky, formerly joint foreman of the Denver & Rio Grande at Durango, Colo., has been appointed master mechanic, with headquarters at Ridgway, Colo., succeeding Mr. J. A. Edwards resigned.

Mr. J. T. Flavin, formerly master mechanic of the Chicago, Indiana & Southern at Gibson, Ind., has been appointed master mechanic of the New York Central at Elkhart, Ind., succeeding Mr. M. D. Franey.

Mr. A. T. Kuehner has been appointed motive power inspector of the main line of the Baltimore & Ohio, and Mr. E. G. Cromwell has been appointed general foreman of the same road, with office at Cumberland, Md.

Mr. Elmer A. Borell, formerly general air-brake inspector of the Philadelphia & Reading, has been appointed engineer motive power, with office at Reading, Pa., and the position of general air-brake inspector has been abolished.

Mr. H. E. Warner has been appointed superintendent of the New York Central shops at Elkhart, Ind. He has been over 12 years in the employ of the company, filling the position of piece-work inspector, shop inspector, and latterly general foreman.

Mr. W. A. Stockbridge, formerly electric engineer of the Northwest System of the Pennsylvania Lines west of Pittsburgh at Fort Wayne, Ind., has been appointed electrical engineer in the office of the general superintendent of motive power at Pittsburgh, Pa.

Mr. William Gemlo, formerly master mechanic of the Minneapolis & St. Louis, has been appointed road foreman of engines, with office at Watertown, S. D., and Mr. R. Haylor has been appointed to a similar position, with office at Fort Dodge, Ia., both on the same road.

Mr. George Hodges has been elected chairman of the committee on relations

between railroads of the American Railway Association, succeeding Mr. Arthur Hale, resigned. Mr. Hodges has had a wide experience as a railroad man and is eminently qualified for the important position.

Mr. W. C. Van Horn has been appointed superintendent division of the Pittsburgh division of the Baltimore & Ohio, with headquarters at Pittsburgh, Pa. Mr. Van Horn has been engaged in the operating department of the company for the past 15 years, and was latterly terminal trainmaster at Chicago Junction, O.

Mr. J. V. Kennedy has been appointed general superintendent of the Cincinnati Northern, with office at Van Nest, O., succeeding Mr. M. A. Neville, resigned to engage in other business, and Mr. J. T. Hayes has been appointed superintendent of the Cleveland-Indianapolis division of the same road, with office at Bellefontaine, O., succeeding Mr. Kennedy.

Mr. L. E. Jordan, formerly president and general manager of the Vulcan Process Company, Minneapolis, Minn., has disposed of his interest in the company and has been succeeded in office by Mr. Clifford N. Lockwood, who will also have the position of treasurer. The company deals in oxy-acetylene apparatus and supplies.

Mr. Thomas Lewis, formerly master mechanic of the Lehigh Valley, with office at Auburn, N. Y., has been appointed general boiler inspector for the system, with headquarters at Sayre, Pa., and Mr. M. Jefferson, formerly assistant master mechanic of the New Jersey and Lehigh division at Easton, Pa., succeeds Mr. Lewis as master mechanic at Auburn, N. Y.

Mr. L. Fisher, formerly district master mechanic of the Canadian Pacific at Revelstoke, B. C., has been appointed district master mechanic on the same road, with office at Canbrook, B. C. Mr. S. West, formerly district master mechanic at Kenora, Ont., has been transferred to Medicine Hat, Alta., succeeding Mr. R. Braun, who has received a commission as lieutenant in the Canadian army.

Mr. W. H. McDonough is reported to have been selected as president of the Vulcan Brake Shoe & Equipment Company, recently organized. Mr. R. M. Brower and Mr. E. B. Smith, formerly in charge of the sales department of the American Brake Shoe & Foundry Company, vice-presidents. Mr. F. W. Grant, formerly assistant to the vice-president of the American Brake Shoe & Foundry Company, will be secretary, and Mr. R. N. Hill, engineer of tests.

Mr. W. H. Wood has been appointed superintendent of the electric power plants of the Baltimore & Ohio, with



headquarters at Baltimore, Md., succeeding Mr. T. F. Foltz, resigned. Mr. Wood is a graduate of the University of Arts & Sciences, following which he was connected with the Standard Steel Company at Burnham, Pa., and latterly as consulting engineer with Mr. A. C. Wood. Mr. Wood is also an able authority on steam boiler plants.

Mr. M. J. Karibo, formerly master mechanic of the Cleveland, Cincinnati, Chicago & St. Louis at Mattoon, Ill., has been appointed superintendent of the general repair shops on the same road at Beech Grove, Ind. Mr. M. J. Butler, formerly general foreman of the machine shops at Beech Grove, has been appointed master mechanic at Bellefontaine, O. Mr. E. J. Buckbee, formerly general foreman of the Mt. Carmel, Ill., shops, has been appointed master mechanic at Mattoon, and Mr. Z. A. Baird has been appointed general foreman at Mt. Carmel, Ill.

Mr. L. B. Morris, general sales manager at New York of the Cambria Steel Company, has also been appointed manager of sales of the Midvale Steel Company, and the Worth Brothers Company. Mr. H. W. Hayes has been appointed manager of sales of the three companies in the Boston district. Mr. E. S. Harris has been appointed manager of the same companies in the Philadelphia district, and Mr. L. E. McLain becomes manager of sales of the same companies in the Pittsburgh district.

Mr. J. T. Slattery, president of the Air Brake Association and superintendent of



J. T. SLATTERY.

the Mountain division of the Denver & Rio Grande, has had a wide experience as an all round railroad man. He is from Des Moines, Ia., and graduated with honors from the Central Business College of Denver, Col. He entered railway service in 1886 in the construction department of the Chicago & Northwestern. In 1889 he was employed in the freight department

of the Denver & Rio Grande, and also for some time on the Chicago, Burlington & Quincy. In 1893 he returned to the Denver & Rio Grande, and in a few years he was promoted to locomotive engineer, in which position he continued for nine years. In 1906 he was appointed general air-brake instructor, and in 1911 trainmaster at Tucker, Utah, and in 1912 superintendent of the Green River division,



B. A. CLEMENTS.

with office at Helper, Utah. In 1913 he was transferred to the Colorado lines as superintendent of the Mountain division, with headquarters at Salida, Colo., and in which position he is employed at the present. Mr. Slattery is a genial and popular character among railway men, a ready and fluent speaker and an accomplished parliamentarian.

Mr. B. A. Clements, who has been elected vice-president of the Rome Merchant Iron Mills, is from Indianapolis, Ind., and entered the service of the Illinois Central as messenger boy in 1891, and served successively as clerk and stenographer to the road master and superintendent of the Chicago and St. Louis divisions until July, 1898, when he became secretary to the general passenger agent of the Michigan Central at Chicago. In 1899 he returned to the Illinois Central as secretary to the general superintendent of transportation, and from 1902 to 1904 was chief clerk to the general manager. From 1906 to 1909 Mr. Clements was chief clerk to the vice-president in charge of operation, when he was appointed general agent, operating department, reporting to the president. In 1910 Mr. Clements left the Illinois Central to accept the position of Western railroad representative of Worth Bros., with headquarters at Chicago, which position he held when elected to the new position as noted above, with headquarters at 30 Church street, New York. Mr. Clements has had unusual experience, which has given him intimate knowledge of railroad men and railroad problems. His person-

ality has attracted hosts of friends and acquaintances. This and his knowledge of the metallurgy of iron are most valuable assets in his new business connection.

**Obituary.**

**CHARLES J. CARNEY.**

Charles J. Carney, one of the managers of the American Locomotive Works at Dunkirk, N. Y., died April 12 and was buried on the 15th, his funeral having been among the largest and most influentially attended interments ever held in that city. The honorary bearers, all old friends and associates of Mr. Carney, were James McNaughton of New York, vice-president of the American Locomotive Company; R. J. Gross, John R. Magarvey, manager of the Schenectady plant of the American Locomotive Works; H. C. Hequembeurg of New York, Harry Swoyer, general manager of the Brooks works of the American Locomotive Company; H. H. Droege, vice-president of the Merchants National Bank.

The active bearers, all members of Dunkirk commandery No. 0, K. T., were Henry Adams, J. A. Taylor, A. E. Nugent, R. H. Heppell, A. W. Cummings and John W. Holmes. With the exception of Mr. Holmes all are past eminent commanders.

All the public organizations in Dunkirk and of some neighboring towns sent delegates to the funeral and a general feeling was manifested to honor the departed citizen.

In 1876 the writer went to work in the



CHARLES J. CARNEY.

Brooks Locomotive Works and worked for several months under Mr. Carney whom he found to be the most helpful, obliging and efficient superior he has ever come in contact with. He was an excellent leader of men and by precept and example pushed forward in an admirable manner the work he was engaged upon supervising.

## Dr. Angus Sinclair Comments on the Education of Apprentices, Past and Present

In the meeting of the mechanical staff of the Erie Railroad, presided over by Mr. William Schlafge, general superintendent of machinery, reports are made about the value and utility of certain articles. These we discuss and valuable information is obtained that keeps one in close touch with the mechanical progress of the day. There are now six apprentice schools and another one is about to be opened, all of which add considerably to my work. It is very good practice for me, as I have to study to make the talks varied and interesting to the boys. The enterprise of the Erie Railroad people in maintaining these schools is highly commendable and is destined to perform useful work for the mechanics of the country. It is quite a contrast to the treatment which the young mechanics received in Scotland during my time. At Arbroath the practice was to start the young mechanic on some tool, and there he remained during the whole of his apprenticeship, unless he made personal efforts to get moved to other work, and few of them had what was called cheek to complain. There was no attempt to give the youngsters any education that would apply to mechanics. I was always ambitious to learn things, and once started a move to organize a night school, but it came to nothing because there was no sentiment among the other boys in favor of learning things they were not compelled to learn.

I had managed to acquire considerable knowledge; was gleaned under difficulties that are amusing to reflect upon. There was an old dominie in Arbroath who was in the habit of teaching navigation to sailors, and the idea struck me that he might give me instruction in mechanics, so I went and asked him to do so. He did not know anything about mechanics, but he urged me to take a course of navigation, which I declined. A few days afterwards he came into the shop and told me he had found something that would suit me. "All useful knowledge," he said, "is embraced in works on moral philosophy. I am well acquainted with that notable treatise on moral philosophy by Dr. Dougald Stewart, and I advise you to take a course of study on that invaluable subject." I took the course and bought the book, but it proved excessively dry labor.

When I had spent two winters toiling over Dougald Stewart, I accidentally encountered a copy of Chalmers Information for the People, and concluded that it was the information I needed. I asked Dominie Watson to change from Dougald Stewart, but he would not do that, so I had to labor alone, which I proceeded to do. I again tried to form a class among

the workmen, but failed in the attempt.

When I look back upon my different schools and schoolmasters, I feel moved to give much credit to a boilermaker called Willie Laurie. When I was waiting for the bell to ring (we called it the pot) on the first morning I was assigned to work in the boiler shop, the men began discussing the best kind of drinks. A variety of beverages had had their merits gone over, when someone remembered that the views of an expert had been overlooked, and asked, "What do you prefer as a good drink, Willie?" "Well, men," was the reply, "when I have my choice there's naething I like better than a glass o' whiskey mixed with another glass."

I was appointed tool carrier for this Laurie. The first job we went on was a leaky fire box. We had been inside about two hours, and when we came out Willie asked me, "How many fire bars are in that box?" I did not know, and said so. "Didn't you see them?" he persisted. "Yes, I saw them, but did not count." "How many d'ye think?" I made a wild guess, and he laughed, saying I should never make a mechanic if I did not see things better than that. That was only the beginning. Every day he had some puzzling question to ask, and that put me studying every detail of the boiler in order to be able to answer his questions. That practice was continued and became a habit.

### Erie Apprentices Hear Dr. Angus Sinclair.

The *Daily Messenger*, published in Meadville, Pa., has the following comments in its issue of April 6:

"The Erie apprentices at the local railroad shops were indeed fortunate to have Dr. Angus Sinclair address them yesterday afternoon in their school room, on general mechanical topics.

"Dr. Sinclair is one of the most eminent mechanical authorities living today and is indeed a striking example of what can be obtained through self-effort, as he attained his success entirely by study and close application to higher mechanics.

"During his talk, Dr. Sinclair brought out very forcibly the changed conditions under which the present day apprentice is taught a trade, as compared with the conditions at the time when he was an apprentice and that how, under the present management, the boy is encouraged in every way possible to become successful, while in older times there were so many obstacles to be overcome that but few had the staying qualities to reach the goal.

"He dwelt to some extent on the lives of celebrated mechanics who gave great inventions to the mechanical world and

how these inventions influence today our present advanced type of steam power engines. These men did not have the advantage of instruction schools in vogue on many of the railroads and industrial shops today but worked alone on their own initiative.

"The apprentice today has every opportunity to become a mechanical engineer, particularly the apprentices on the Erie railroad, for this road was not only one of the pioneers in this movement but they have bettered their instruction to such an extent that today it is second to none.

"Dr. Sinclair was very much impressed with the fine appearance made by the apprentice boys at the Meadville shop and congratulated the management on having such a nice lot of young men in training for future mechanics. He is indeed a genial talker and the boys were very much impressed by his address and the management is much pleased with their progress."

### Sun or Moon.

When railways first began operating in the British Isles there was considerable conviviality among the trainmen, which was afterward sternly suppressed by the companies, although there were at first strong protests against rules that interfered with personal liberty. The writer remembers the time when a teetotal trainman was spoken of as a sneak.

In the good old drinking days there was a club of railway men in Arbroath, Scotland, the members being bent on maintaining the old habits. The story is told of two famous drouths leaving the club after a protracted sitting. As they wended their way homeward, Jack Moncrieff remarked to his friend, Tom Guthrie, "Why, Tom, it's getting late; there's the sun rising."

"That's no the sun," said Tom; that's the moon."

They proceeded to argue the question, when a newcomer appeared.

"Freen," said Jack, "we've been having a little argument. I say that's the sun rising and my freen says it's the moon. We are going to refer to you for decision."

"Well, men," said the newcomer, you will have to get someone else to settle your dispute, for I'm a stranger in this town."

### Sounds Right.

A conductor and a brakeman on a Montana railroad differ as to the proper pronunciation of the name Eureka. Passengers are often startled at this station to hear the conductor yell:

"You're a liar! You're a liar!"

And then from the brakeman at the other end of the car:

"You really are! You really are!"



“Speakin’ of mixtures,” said Old Jerry as he refilled his jimmy pipe, “I’ve never used a cooler mixture than flake graphite and oil.

“In the old days,” continued Jerry, “when 689 was the fastest engin’ on the road, the boys used to wonder why it was never laid up in the tinker’s shop an’ why it never broke a schedule. ‘Fine ole engin’, Jerry,’ they used to say. ‘Nix, flake graphite,’ I says. And takin’ an old Dixon ad from my pocket I read: ‘Write for

## “Graphite Products for the Railroad”

and Sample No. 69.’ (You see I didn’t mind givin’ away the dope.)

“And, Judgin’ by the way Dixon’s Flake Graphite is bein’ used nowadays, every mother’s son of them, an’ their friends, must have wrote for that booklet and sample.”

**Joseph Dixon Crucible Company**

Established 1827

**JERSEY CITY, N. J.** 38-C

### Railroad Equipment Notes.

The Union Pacific has ordered 25,000 tons of rails from the Illinois Steel Company.

The Southern Railway has ordered 92 passenger train cars from the Pullman Company.

The Atlantic Coast Line has ordered 10,500 tons of rails from the Pennsylvania Steel Company.

The Louisville & Nashville Railroad has ordered 950 under-frames from the Pressed Steel Car Company.

The Norfolk & Western Railway is reported as ordering 10 locomotives from the American Locomotive Company.

The Kansas City Southern Railway is said to have ordered 10 locomotives from the American Locomotive Company.

The Chicago & Northwestern let contracts early in March for 14 Pacific type engines, 35 Mikados and 28 switching engines.

The Southern Railway has ordered 20 Santa Fe type and five Mountain type locomotives from the Baldwin Locomotive Works.

The Cuban-American Sugar Company, New York, has ordered two Mogul type locomotives from the Baldwin Locomotive Works.

The Philadelphia & Reading Railway has ordered 26 Mikado and six Mallet type locomotives from the Baldwin Locomotive works.

The St. Louis Southeastern Railway reported as ordering 20 locomotives, has placed this order with the Baldwin Locomotive Works.

The Cincinnati, New Orleans & Texas Pacific Railway has ordered 300 under-frames from the Western Steel Car & Foundry Company.

The Chicago Great Western Railroad has ordered three Pacific and seven Santa Fe type locomotives from the Baldwin Locomotive Works.

The Pennsylvania Steel Company, Steelton, Pa., has ordered two six-wheel switching locomotives from the Baldwin Locomotive Works.

The New York, Ontario & Western Railway has ordered 3,500 tons of rails from the Lackawanna Steel and Bethlehem Steel companies.

The Chicago, Milwaukee & St. Paul

Railway is building 75 logging cars in its Tacoma shops for the Puget Sound & Willapa Harbor Railway.

The Wabash Railway has contracted for 14,000 tons of rails, divided between the Lackawanna Steel Company and the United States Steel Corporation.

The Central Railroad of New Jersey has ordered five eight-wheeled switching locomotives from the American Locomotive Company, and will build three in its own shops.

The Buffalo, Rochester & Pittsburgh has ordered 5,500 tons of rails from the Lackawanna Steel Company, and is reported to have ordered 5,000 to 10,000 tons from other companies.

The Southern Railway has increased its recently reported order to the Baldwin Locomotive Works from 20 Santa Fe and five Mountain type locomotives to 25 Santa Fe and 15 Mountain.

The French State Railways has been getting prices in this country on 3,500 freight cars, and the Italian State Railways have asked for prices on 4,000 freight cars of various kinds.

The French Government, it is said, has now ordered about 100,000 tons of rails of various weights and sizes from American mills, of which about 140,000 tons will be rolled by one company.

The machine shops and roundhouse of the Southern Pacific Company at Naco, Sonora, were destroyed by fire April 10. The loss, including three locomotives and two coaches, is estimated at \$300,000.

The Union Tank Line Company has increased its order for tank cars placed with the American Car & Foundry Co. from 750 to 1,000 cars. This makes a total of 2,000 cars ordered by this company this year.

The El Paso & Southwestern Railway has ordered two Mikado type locomotives from the American Locomotive Co. Cylinders will be 29 by 30 in.; driving wheels, 63 in.; total weight in working order, 321,000 pounds.

The Long Island Railroad has ordered four eight-wheel locomotives from the American Locomotive Company. Cylinders will be 23 by 28 in.; driving wheels, 56 in.; total weight in working order, 195,000 pounds.

The Pekin Hankow Railway, of China, has ordered 10 consolidation type locomotives from the American Locomotive Company. Cylinders will be 22 by 26 in.;

driving wheels, 53½ in., total weight in working order, 106,000 pounds.

The Southern Railway has ordered 1,750 box cars from the American Car & Foundry Company and 1,500 from the Mount Vernon Car Manufacturing Company, besides 1,975 box cars which it is understood will be built by the Lenoir Car Works.

The following roads were in the market last month for engines: Peoria & Pekin Union, 5; Chicago Great Western, 20; Burlington, 30; Bessemer & Lake Erie, 5; Monon, 9; Canadian Pacific, 6; Pennsylvania Lines West, 50; Southern Pacific, 95; Canadian Northern, 48; Chicago Junction, several switching engines; Frisco Lines, 30.

The Pennsylvania Railroad system has placed orders for 205,000 tons of heavy section rails, including 125,000 tons for lines east and 80,000 tons for lines west of Pittsburgh. The present order for 1917 requirements compares with 175,000 tons for 1916 and 167,500 tons in 1915, and is one of the largest rail orders ever placed by the Pennsylvania.

The International Great Northern has let contracts for large repair shops at San Antonio, Tex. The main building is to be 300 feet by 125 feet, and will contain the smith shop, boiler shop and machine shop, equipped with an electric crane. There will also be a roundhouse, 18 stalls; copper shop, air shop, and boiler-washing plant, 40 by 160 feet; woodwork shop, 62 by 164 feet; car shed, 65 by 68 feet; store room, 36 by 105 feet, about 12 miles of sidings; total cost, about \$300,000 for the entire plant and equipment.

#### Nationalization of Cuban Railroads.

The American Minister at Habana, Cuba, has informed the Department of State in a dispatch dated February 18, 1916, that the President of Cuba has signed a decree dated February 17, 1916, appointing a commission to study the question of the nationalization of the railroads of Cuba. The committee is expected to report within six months.

#### Railway Pay on the Baltimore and Ohio.

Engineers, \$5.24; conductors, \$4.47; firemen, \$3.22; other trainmen, \$3.09; all employees, \$2.53; general office clerks, \$2.54; station agents, \$2.33; other station men, \$1.98; carpenters, \$2.66; other shopmen, \$2.36; section foremen, \$2.20; other trackmen, \$1.59; switch tenders, crossing tenders and watchmen, \$1.71; telegraph operators and dispatchers, \$2.56; all other employees and laborers, \$2.21.

#### Safety on the Kentucky Central.

President Howard Elliott, of the New Haven line, is a ready and humorous speaker, so he is naturally in request for social gatherings when speeches are in order. A few weeks ago Mr. Elliott spoke on Safety First to a Boston audience and said:

"Why, the day may come," he declared, "when all roads will be as safe as the Great Kentucky Central.

"A passenger on the Great Kentucky Central said to the conductor:

"Do you use the block system on this line?"

"No, we ain't got no use for the block system, stranger."

"Oh, I suppose, then, you use electric or pneumatic signaling?"

"No; no use for them nuther."

"Then you have train despatchers, and run your train by telegraph?"

"Nope."

"But when you stop between stations you at least go back a hundred yards and flag the rear?"

"Nope, stranger; nope."

"Then," said the passenger angrily, "all I've got to say is that this road is run in a criminally reckless manner."

"The conductor frowned, took out a plug of tobacco and snapped off a chew viciously.

"Stranger," he said, "if you don't like this line say so, and I'll stop the train and you can git off and walk. I'm the president of this line and the sole owner. This is the Great Kentucky Central, and, stranger, don't you forget it. She's seven miles and a half long. She runs from Paint Rock to Nola Chucky. This is the only train that travels on the Great Kentucky Central, and what you hear snortin' ahead is our only engine. We ain't never had a collision. We ain't never had an accident. What's more, we never will. Now are you satisfied, stranger, or will I pull the string and let you git out and walk?"

Angus Sinclair, when superintendent, engineer and conductor of the Chicago, Clinton & Western, seven miles long and known as the "Plug," made the same remark repeatedly to disgruntled passengers who complained of the seven miles an hour train velocity. They were always invited to get out and walk, but none did so except one man who fell through a trestle and sued the company for \$10,000 damages. He was awarded three dollars to repair pants that were damaged.

#### Gun Metal.

This alloy has its name because it was at one time largely used for casting guns. The real gun metal contains about 90 per cent. of copper and 10 per cent. of tin, and is one of the strongest alloys. Gun metal should have the composition named, but it is frequently used as a name for bronze and sometimes for alloys containing zinc, as well as tin.

# GOLD Car Heating & Lighting Company

Manufacturers of

ELECTRIC,  
STEAM AND  
HOT WATER  
HEATING  
APPARATUS  
FOR RAILWAY CARS  
VENTILATORS  
FOR PASSENGER  
AND REFRIGER-  
ATOR CARS  
ACETYLENE SYSTEM  
OF CAR LIGHTING

Send for circular of our combination PRESSURE AND VAPOR SYSTEM OF CAR HEATING, which system automatically maintains about the same temperature in the car regardless of the outside weather conditions.

Main Office, Whitehall Building  
17 BATTERY PLACE  
NEW YORK

# Hydraulic

**Riveters Fixed and Portable  
Punches, Shears,  
Presses, Lifts, Cranes  
and Accumulators.**

**Matthews' Fire Hydrants,  
Eddy Valves  
Valve Indicator Posts.**

**The Camden High-Pressure Valves.**

## Cast Iron Pipe

**R. D. Wood & Company**

**Engineers, Iron  
Founders, Machinists.**

**100 Chestnut St., Philadelphia, Pa.**

## Nichols Transfer Tables Turntable Tractors

**GEO. P. NICHOLS & BRO.  
1090 Old Colony Bldg. CHICAGO**

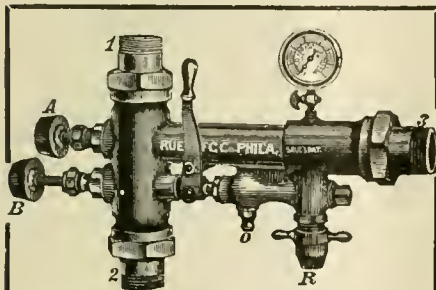

### NOW IS THE TIME to install a Rue Boiler Washer and Tester,

For you will need it when cold weather comes. It will wash out, test and fill your boiler, all with hot water, and have it ready for use in one hour.

THINK IT OVER.  
Catalog on Boiler Washers A-5.  
Catalog on Injectors B-5.

**Rue Manufacturing Co.,  
228 CHERRY STREET  
Philadelphia, Pa.  
Manufacturers of Injectors, Ejectors,  
Boiler Washers and Testers, Boiler Checks,  
Check Valves.**



## ASHTON POP VALVES AND GAGES

The Quality Goods That Last

The Ashton Valve Co.  
271 Franklin Street, Boston, Mass.  
No. 174 Market St., Chicago, Ill.

# Books, Bulletins, Catalogues, Etc.

## "National" Bulletin.

Autogenous welding of "National" pipe is the subject treated of in the April issue of *National Bulletin*, No. 26, and the 52 pages form a volume of instruction that forms a text-book in itself. Many of the articles are written by practical operators who, by their general experience in laying autogenously welded pipe lines, are well equipped to give such information on the subject of autogenous welding, as is most valuable to those contemplating the adoption of this new system of pipe installation. Special stress is laid on the superiority of the oxy-acetylene process, the high temperature of the flame, approximately 6,800 degrees Fahrenheit, makes it possible to produce a very rapid melting and fusion of the metal without burning it. The complete outfit is shown in illustrations, and the accompanying descriptive matter leaves nothing to be desired in the way of thorough instruction in the art of expert welding. Numerous examples of welding are given, and the results having stood the severest tests the process is now in no sense to be regarded as an experiment. The saving of time and expense over the old methods are enormous, and all interested should secure a copy of Bulletin No. 26 from the National Tube Company, Pittsburgh, Pa.

## Staybolts.

The April issue of *Staybolts*, No. 11, issued by the Flannery Bolt Company, contains some remarkable records throughout the railroad field in the last six years, and it should be remembered that it takes years to make a satisfactory showing in the economic performance of a lot of engines based on the ton-mile rating. Instances are given where the flexible staybolts were in use five years during which time not a single staybolt of the flexible kind had failed. The Tate bolt undoubtedly means prolonged service, and while the enterprising company has modestly refrained from claiming perfection, or complete immunity from staybolt fracture, the improvement has been so marked that it would be foolish to ignore the mass of evidence that is presented in favor of its use. Not only so, but the company is constantly experimenting with new designs, so that with added improvements every kind of boiler may be equipped with staying accessories that are unquestionably meritorious in aiding in the safety and durability of the boiler. Bulletin No. 11 is well worthy of perusal by railway men engaged in the mechanical department, and copies may be had on application to the company's office, Pittsburgh, Pa.

## Foreign Specifications for Railway Material

With the object of placing in convenient and accessible form before those in the United States interested in or responsible for railway materials, the Bureau of Standards, Department of Commerce, in connection with its investigation of failures of railway material, has obtained, through the courtesy of the State Department, copies of specifications for railway material—rails, axles, wheels, and tires—used in several European countries. These specifications are given in full, together with a digest and discussion, in Technologic Paper No. 61, just issued. The available data concerning the types and weights of foreign railway equipment, together with those concerning derailments and accidents abroad, are also included in the publication. Persons interested may obtain copies of the paper, which is entitled "Foreign Specifications for Railway Material," without charge upon application to the Bureau of Standards, Washington, D. C.

## Oil Engines.

Fairbanks, Morse & Company, Chicago, have issued catalogue 92 B, describing and illustrating their new type Y oil engines, style H, and in these days of high-priced gasoline, it is well to give attention to the need of an engine that will operate on much lower grades of oil, such as heavy solar oils, gas oils and fuel oils, as well as crude oils as they come from the wells. In almost every section of the country some of these oils may be obtained at less cost than the others, and the ideal engine is that one which will use them without change of any kind in the engine, and at the same time at the lowest possible cost. It is to meet this need that the smaller sizes of type Y have been developed. This type of engine is well adapted for all general purposes, for belt or direct drive. They can be started and require little or no attention. They are especially adapted for railway water stations, pumping plants, or any purpose for which a simple and efficient and reliable pumping unit is required. In many places this is the only satisfactory type of pump, and the only type that can be operated economically. Send for a copy of the catalogue to the company's office, Chicago, Ill.

## Drill Chips.

The editor of *Drill Chips*, the organ of the Cleveland Twist Drill Company, should be in Congress, but we are afraid that he is too honest and too modest to pass through the fiery furnace of an election. His leading article in *Drill Chips* for April is an admirable essay on

"Preparedness." No comments of ours could do it justice. It is one of those gems that should be printed by the million. Every editorial sparrow in America is chirping on the same subject now, but if they would simply reprint Mr. Henderson's incisive observations and keep their own little mouths shut, they would be aiding in a monumental educational work. When the eagle screams all the feathered choirs lapse into silence, but journalists love to listen to themselves, and keep on chattering, and think themselves worth many sparrows. Of the company's fine products, of course, there is a special short article on drilling rails, which, to say the least, is highly illuminating. Copies may be had on application to the company's office at Cleveland, Ohio.

#### Mechanical and Magnetic Properties of Steel.

A review of the work done in correlating the magnetic and mechanical properties of steel has been published by the United States Bureau of Standards in its Scientific Paper No. 272. The magnetic method tests the whole amount of material and not merely some surface phenomenon. It does not destroy the test piece, but leaves it unaltered. Thus it is found to be possible to apply a magnetic test to the identical material that is to enter into a given structure. Copies of the publication, the title of which is "Correlation of the Mechanical and Magnetic Properties of Steel," will be sent free upon request to the Bureau of Standards, Washington, D. C.

The International Association for Testing Materials has designated the subject covered in this book as one of the important problems of today, and has assigned its investigation to a special committee.

#### Young Men and the Electrical Industry.

The above is the title of an illustrated booklet by James H. Collins, issued by the Westinghouse Electric & Manufacturing Company, which begins:

"One day, not long ago, a party of officials from Germany visited the main plant of the Westinghouse Electric & Manufacturing Company at East Pittsburgh. They walked an aisle that seemed a mile long, past countless machines where the operators, a number of whom were girls, were winding insulated wire. They were solid, serious Germans—real well-fattened husbands of the German Hausfrau's ideal. It was a long walk. The most serious member of the party plodded along without comment until the end of the aisle was reached. Then he turned to his friends and said: 'This is a big building.'"

They were taken around a corner and conducted back through another aisle

of the same length full of men and girls and machinery, and again the serious visitor said nothing until the other end was reached. Then he declared:

"This is the biggest building I ever saw!"

Still the tour continued. They turned another corner and walked down a third aisle, and now the serious German was getting winded. When the end was reached, he mopped his brow and exclaimed in astonished conviction:

"Ach! This must be the biggest building in the world!"

Now, suppose a young fellow with his career all before him—say, a liberal arts sophomore, or high school senior—went through the same plant.

He, too, would be impressed chiefly by the size of the place, and very properly. For it is an immense works full of technical apparatus and processes. It is said to be the largest machine shop in the world. Nor is this all of Westinghouse, because the company has plants in other cities of the United States, and in Europe.

A young student would get the general impression that, if he were employed by Westinghouse, he would be connected with a very large concern indeed, with its thousands of workers, and millions of feet floor space, and plants and outfit distributed all over the globe—surely a job to be proud of.

The full text of the pamphlet from which the above extracts were taken can be obtained free from the Westinghouse Electric & Manufacturing Company, East Pittsburgh, Pa., on application.

#### Easy.

A New Yorker had occasion to phone from one suburb to another while visiting in a western city. Upon asking what the charge was he was told fifty cents.

"Fifty cents! For that distance? Great Scott! In New York you can call hell up for fifty cents."

"Possibly," coolly answered the operator. "It's in the city limits."

*Statement of Ownership and Management of RAILWAY AND LOCOMOTIVE ENGINEERING, published monthly at New York, N. Y., for April 1, 1916, required by the Act of August 24, 1912.*

*Editor, Angus Sinclair, 114 Liberty St., New York, N. Y.*

*Managing Editor, James Kennedy, 114 Liberty St., New York, N. Y.; Business Manager, Harry A. Kenney, 114 Liberty St., New York, N. Y.; Publisher, Angus Sinclair Co. (Inc.), 114 Liberty St., New York, N. Y.; Owners, Angus Sinclair Co. (Inc.), 114 Liberty St., New York, N. Y.; Stockholders, Angus Sinclair, 114 Liberty St., New York; James Kennedy, 114 Liberty St., New York; Harry A. Kenney, 114 Liberty St., New York; Mrs. Otto J. Schonbacher, Newark, N. J.*

*Known bondholders, mortgagees and other security holders, holding 1 per cent. or more of the total amount of bonds, mortgages, or other securities: None.*

HARRY A. KENNEY,  
Gen'l Mgr.

Sworn to and subscribed before me this  
twenty-second day of March, 1916,

OLIVER R. GRANT,

Notary Public Bronx County, Certificate filed  
New York County, No. 43.  
My commission expires March 30, 1917.

## Locomotive Engine Running and Management

By ANGUS SINCLAIR

This popular book has been a RELIABLE REFERENCE and comfortable unailing POCKET EDITION.

PRICE, \$2.00

ANGUS SINCLAIR CO.

114 Liberty St.,

New York

## STEEL STAMPS

INSPECTORS HAMMERS

Hand Cut STEEL LETTERS & FIGURES

LATHE TOOLS, TIME CHECKS,

Noble & Westbrook Mfg. Co.

3 ASYLUM ST. HARTFORD, CONN.

You Want Tool Holders  
That Have Made Good



ARMSTRONG TOOL HOLDERS  
WERE AWARDED THE  
GRAND PRIZE

The Highest Possible Award at the Pan-  
ama-Pacific International Exposition  
THEY ALWAYS MAKE GOOD



ARMSTRONG BROS. TOOL CO.  
"The Tool Holder People"  
312 N. Francisco Ave., Chicago, U. S. A.

NEVER SHRINKS OR DETERIORATES



ESPECIALLY PREPARED  
FOR THE ENGINEER

WORKS EQUALLY WELL ON HOT and COLD SURFACES  
CLEANS POLISHES and PRESERVES ALL KINDS OF METALS

GEO. WM. HOFFMAN CO.

Indianapolis

New York

Chicago

San Francisco

Send for FREE Sample

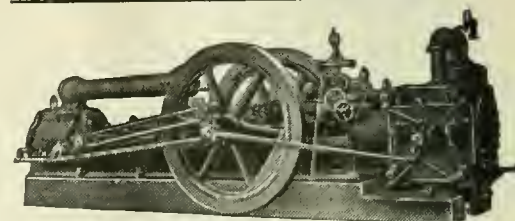

The Norwalk Iron Works Co.

SOUTH NORWALK, CONN.

Makers of Air and Gas Compressors

For All Purposes

Send for Catalog

# Railway AND Locomotive Engineering

A Practical Journal of Motive Power, Rolling Stock and Appliances

Vol. XXIX.

114 Liberty Street, New York, June, 1916.

No. 6

## Stability and Growth of Thermit Welding

### Details of the Process and the Appliances Necessary

Among the railroad shop appliances that have come into almost universal favor during the present century there are none whose merits have stood the test with a higher degree of reliability than that of thermit welding. While the process is well known and thoroughly established, it is well to refer to it from time to time, just as valve-setting and other operations requiring skill should be occasionally described in order that those who may not have had an opportunity of personally do-

ing powder, and rapidly produces superheated liquid steel and slag, at a temperature of about 5,000 degrees Fahrenheit. It is sufficiently hot to melt any metal with which it comes in contact and mixes with to form a solid enduring mass. By its use locomotive frames and other parts that may have sustained fracture may be welded with such slight dismantling as may be necessary to leave the broken parts exposed to the mold with which it is necessary to surround the fracture. The mold

for a space of two inches on each side of the opening, so that when the heat is applied there will be no grease or other matter left to leave a space between the mold and the frame. Screw jacks or other appliances should be used to hold the frame in correct alignment and also to expand the opening from  $\frac{1}{8}$  in. to  $\frac{1}{4}$  in., according to the size of the frame, allowing for the contraction incident to the cooling of the superheated portion of the metal. A preheating process is neces-

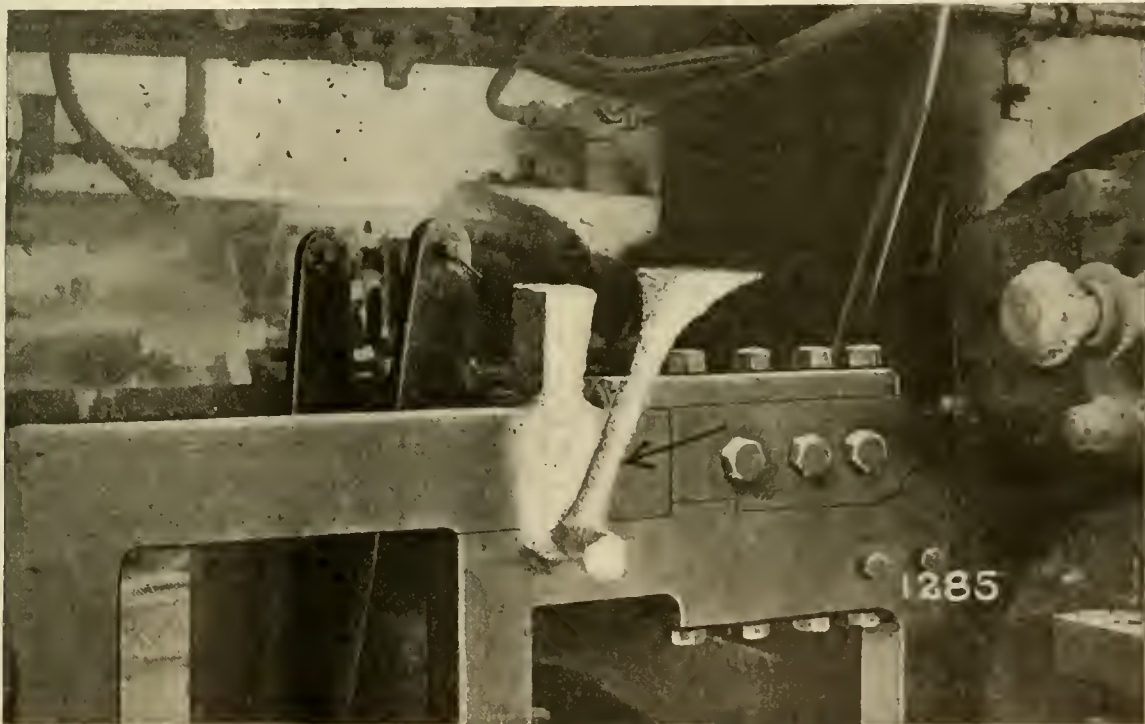

FIG. 1. LOCOMOTIVE FRAME WELD SHOWING POURING GATE RISER AND WELD.

ing the work may become familiar with the details of the operation, thereby extending their general fund of information in regard to the improved methods of repair work, and getting ready, if need be, to perform the operations themselves, if the occasion arises.

The Thermit process, so called, consists of a chemical reaction between a mixture of aluminum and iron oxide. The compound is ignited by means of special ignit-

box requires to be about 15 inches wide to allow sufficient space to thoroughly envelop the fractured part. The broken portion must be cut out at least one inch in width. In cutting out this portion a cutting flame of gas or oxygen may be used, or a series of holes may be drilled and the projecting metal removed so that the opening is clean to allow the free flow of the molten metal in the opening. The frame should also be carefully cleaned

sary for the assurance of a perfect weld. Sometimes a small brick furnace is necessary to properly preheat the ends of the fractured portion.

A pattern made of yellow wax, which must be heated until it is plastic, should then be constructed in the form of a collar. The opening between the ends of the frame should also be filled with wax, and a vent hole extending from the location of the heating gate to the riser. A piece

of stout twine can be imbedded in the wax and drawn out after the pattern has been formed. The mold box may then be placed in position and securely blocked so that no weight will rest on the frame. The molding material consists of one part fire clay, one part ground brick and one part fire sand. The material should be carefully screened and moistened with enough water to make it pack well, and should be at least four inches thick and firmly packed to resist the action of the molten

should be kept on until the mold is dried and a workable heat produced on the parts to be welded.

The thermit charge should be thoroughly mixed before being placed in the crucible. The ignition powder should not be added until the thermit charge is ready to be ignited. The preheating opening should then be carefully closed and packed hard to prevent the molten steel finding a way through this opening. Thermit will not ignite from the heat of the preheater.

gate and the sections easily broken off.

In the construction of the crucible there is a hard burned magnesia stone in the bottom, and the sides are magnesia tar-lined. This will last from 16 to 20 reactions. In calculating the amount of thermit to be used, a simple rule is to ascertain the amount of wax used in forming the mold, by weighing the wax before and after the operation, the difference being the quantity of wax used and this weight in pounds, multiplied by 25, will

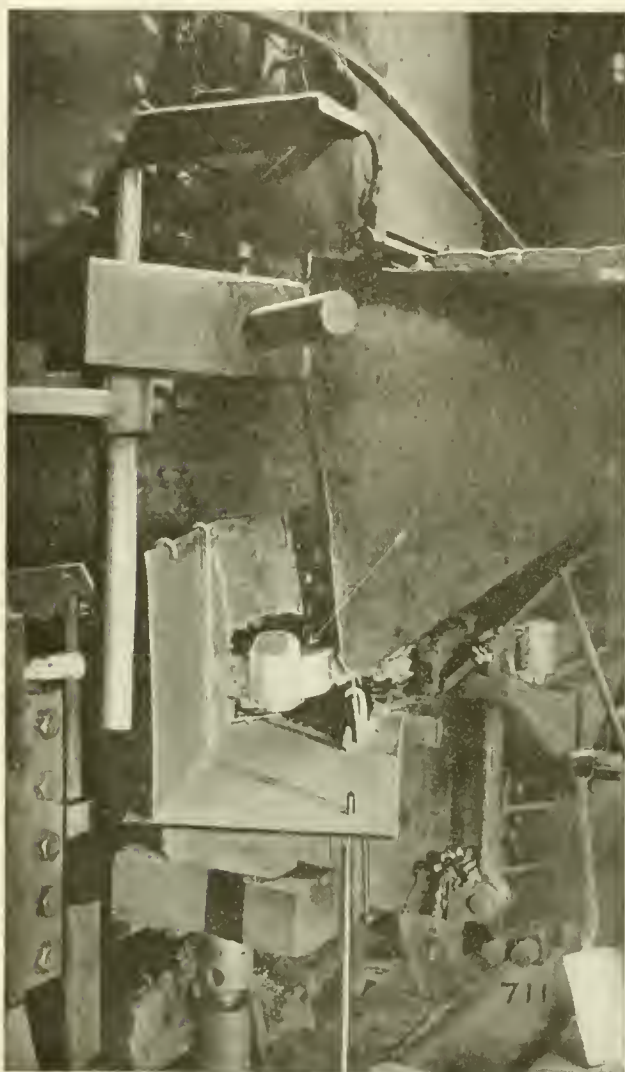

FIG. 2. WAX IN PLACE FOR WELDING MUD RING ON LOCOMOTIVE.



FIG. 3. CRUCIBLE AND MOLD BOX IN POSITION FOR WELDING MUD RING.

metal. A wooden gate pattern is set at the lowest point of the wax pattern, and over this the riser pattern about one inch away from it. Holes are made in the mold with No. 8 or 10 gauge steel wire, so that all gases will have means of escape. The crucible should be adjusted about 3 inches above and directly over the center of the pouring gate. The burner of the thermit preheater is then pointed into the heating gate of the mold, and the blast should be applied lightly at first. The wax will burn out and leave a mold the shape of the wax pattern. The heat

About one-half teaspoonful of ignition powder placed on top of the thermit in the crucible is sufficient. A red-hot iron or parlor match will ignite the powder which in turn ignites the thermit and the fusion of the thermit should be allowed to continue half a minute before tapping the crucible. The molten metal will then flow easily and rapidly into the mold which should not be disturbed for several hours so as to anneal the steel in the weld. After removing the mold holes may be drilled in the projecting portions of the metal left in the riser and pouring

give the proper quantity of plain thermit required for all welds up to 150 lbs. of thermit. To this must be added 1 per cent of pure manganese, 1 per cent nickel thermit and 15 per cent mild steel punchings. It may be added, however, that the relative portions after careful and repeated experiments are now to be had already mixed and ready for use. In this regard the Goldschmidt Thermit Company has perfected what is known as railroad thermit, which can be relied upon as containing the best alloys calculated not only to produce the most durable combination,



but to moderate the intensity of the heat, thereby preventing burning of the metals without interfering with the efficiency of the weld.

Referring more particularly to the accompanying illustrations, Fig. 1 shows a

strongly supported from beneath and the heated metal would certainly bulge downwards by reason of its superincumbent weight when the welded part would be in a state of fusion.

Coming to Figs. 4 and 5, these are self-

air cushion or pocket cannot be formed in the process of filling the mold. The riser also forms a receptacle to which the slag or aluminum oxide rises and allows the clean alloy to form in perfect purity on the portion desired. The figures also show

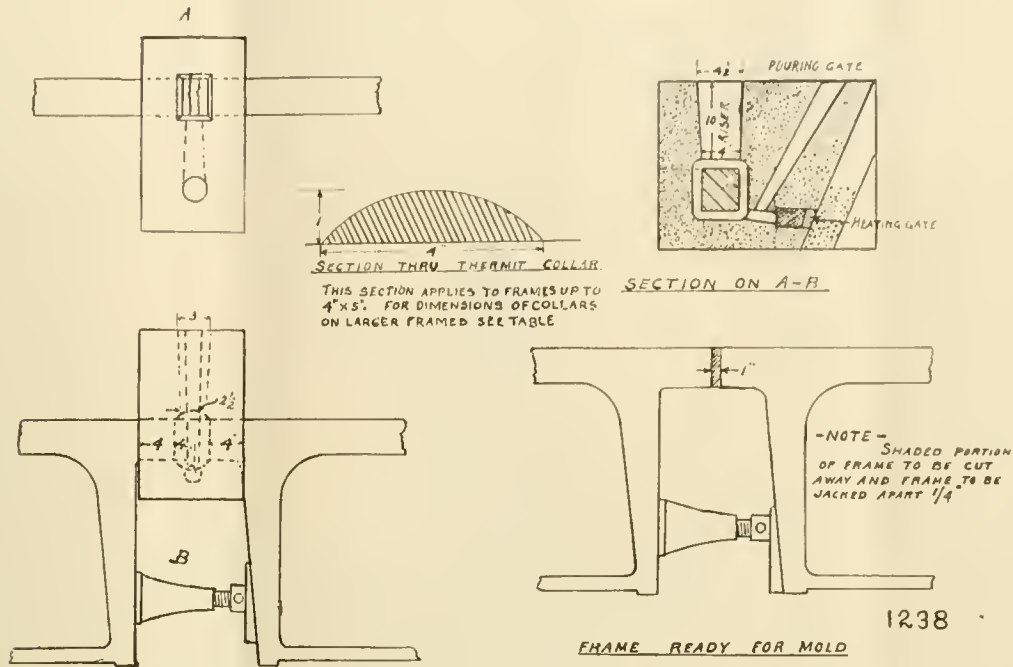

FIG. 4. METHOD TO BE EMPLOYED IN WELDING LOCOMOTIVE FRAME BROKEN IN JAW.

view of a double weld in a locomotive frame which has been substantially joined, and is now ready to have the projection removed, the upper part usually being drilled through, and broken off, and the lower part, if necessary, machined if

explanatory, and are of particular interest as showing the details in regard to the exact location of the heating gate or opening through which the adjoining ends of the fractured part are to be preheated, also the pouring gate and riser, from

a just proportion of the necessary thickness of the packing material already described.

In conclusion it may be added that these details are all the result of extensive experiments conducted through a series of

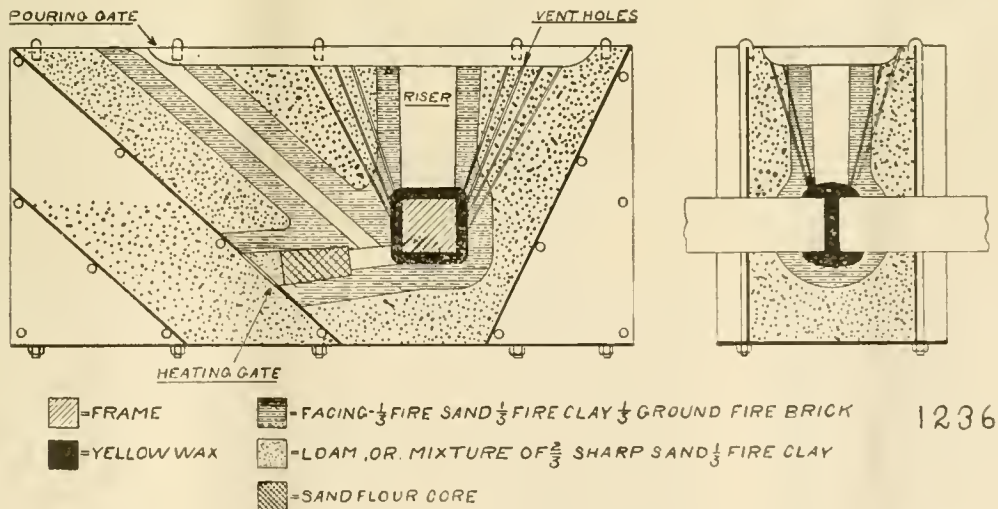

FIG. 5. METHOD TO BE EMPLOYED IN CONSTRUCTING MOLDS FOR MAKING THERMITE WELDS AND MATERIALS NEEDED.

spring or brake hanger should interfere. Fig. 2 shows the wax mold in place on a cracked mud-ring, preparatory to applying the mold box and crucible, and Fig. 3 shows the crucible and mold box in position ready for welding the mud-ring. It will be noted that the mud-ring is

which it will be noted that the heating gate is shown as closed, so that the flowing metal cannot find an outlet in that direction, but is compelled to pass into and around the parts to be welded. The vent holes are also shown, which are a very necessary part of the appliance so that an

years, and on every conceivable variety of conditions, and are soon learned by skilled workmen who, after a few brief lessons, have shown that degree of readiness to avail themselves of improved means and methods, which is so gratifying a characteristic in the American mechanic

# Requirements of An Air Brake

## Great Loss if Brake is Not What it Should Be

By WALTER V. TURNER, Assistant Manager Westinghouse Air Brake Co.

In previous issues I have pointed out the necessity for an efficient foundation brake gear for passenger equipment cars, considering a single vehicle, but when 15 to 18 of the modern heavy cars are being hauled by a single locomotive, as is the present practice, other and more difficult problems are presented. The efficient braking force mentioned must be available not only for one car or one application, but any number of them. With the automatic brake, the ability to recharge the auxiliary reservoirs has been the limit to the number of full applications of the brake obtainable in a specified length of time; therefore, in order to obtain the maximum possible safety with the automatic brake, it is necessary, in the first place, to secure the highest permissible braking ratio and, in the second place, to be able to secure the maximum retarding effect at any time, regardless as to how thoughtless the operator may be in wasting the compressed air from the brake system.

This important problem of railroad operation is not only affecting the safety of passengers, the preservation of freight, and the protection of rolling stock, but is also affecting the economy of operation with respect to time and the earning power of both men and equipment, which is the important factor in determining whether the money invested in the brake is profitable or otherwise. Obviously, the more congested the traffic, the greater the loss if the brake in its operation is not what it should be, and while the returns realized from an efficient brake are largely indirect, as are those of the roadbed and the coal that is burned in the firebox, they are none the less sure and of a greater per cent. On the other hand, if neglected, the effect is much the same as indirect taxation by means of which one may be taxed into bankruptcy without realizing it.

With the brake stopping power is the first, but not the only consideration, and in order to efficiently meet the demands of modern service conditions, and provide for those of the immediate future, the brake must combine with flexibility and simplicity, safety, besides being perfectly interchangeable with existing apparatus and, as far as human foresight and ingenuity can make it, fool proof.

A practically perfect brake must be automatic, durable, simple, always ready, responsive and flexible, the latter of which involves the elements of

power, time and amount of reduction, and in addition it is imperative that in case of emergency the maximum braking ratio covered in the design be obtained with the time and reduction elements reduced to a minimum, to the end that the stop may be made in the shortest possible time. For service or regular operation, however, all these elements should be extended to the end that the trains can be handled without shock, and accurate stops made, and these factors vary in importance and degree according to the service, where the speed is very high, the power development should have the chief consideration, while where the speed is generally low the other elements should have predominance in the design, but it is where the speed varies from the very high to the very low that all elements must have equal consideration and each be developed along lines that will mean the least sacrifice to the others, keeping in mind that at all times, in time of danger, to stop is the chief consideration.

In making ordinary service stops in passenger service, there are always three things to be considered, accuracy, smoothness and the question of time. The shortest possible stop that can be made is to apply the brake in full and allow the train to come to a standstill, but in so doing two things are sacrificed, accuracy and smoothness, for this certainly would not produce a smooth stop and the accuracy would depend entirely upon the judgment of the operator when making that particular brake application. The smoothest possible stop is to shut off the engine and drift to a standstill. In the latter case a great amount of time would be sacrificed, and the point at which the stop would be completed would be altogether indefinite, hence neither of the methods can be followed in actual practice.

In order to obtain all the three points mentioned, it is necessary to have means of applying the brake with the maximum brake cylinder pressure that the speed will warrant and, when approaching the point at which the stop is to be made, by this means is to "feel" the way to the proper point and have comparatively very little pressure in the cylinders when the stop is completed. In this way the shortest stop, smoothness and accuracy considered, is possible, leaving very little, if any, pressure in the cylinder to be exhausted when the signal to start is given, and

the start may be made immediately. Such a brake is certainly a flexible one and the brake which originally possessed them to a maximum degree was the straight air brake, but this perfection is now also possessed by the new passenger brake equipments and has been secured through means which insure a higher degree of safety than ever before attained in the art of train braking.

From a viewpoint of simplicity, straight air possesses this feature to a marked degree so far as operation is concerned, and the degree of simplicity possessed by the straight air brake will possibly never be obtained in a purely automatic system, because certain complications arise in the operation of an automatic brake which are not present with straight air as, for instance, when a number of cars are coupled together, but the fact that we have complications is not necessarily detrimental, and it does not follow that a more complex system should not be adopted, for, as an example, we would not think of going back to an old wood burning locomotive in place of the splendid, but vastly more complex, locomotives of today, simply because the latter are much more complicated. It is a question of results, and if the results obtained justify the means employed, that is sufficient.

In the recent development of automatic brakes, especially those for passenger service, we have, all things considered, increased the simplicity greatly over that of the old standard. With the latter, proper operation depended largely upon the kind of a man that handled it, his experience, knowledge of the brake, judgment and intuition; being unable to graduate his release, he required a far greater perception of distance and speed and better judgment in making stops. Also knowledge of the road, condition of rail and other factors that necessarily enter into automatic brake operation affected the operation of the old brake to a much greater degree than the new.

By the feature of "fool proof" I mean reducing the human element to the lowest possible factor; with the old standard type of passenger brake it was possible to so use the supply of compressed air as to seriously reduce the braking power, but with modern equipment it is impossible to do this, as maximum braking power is at all times available; also the car reservoirs being constantly charged, or recharged, there

is always the same stored pressure to draw from; moreover the brake will always respond and for a given reduction the same brake cylinder pressure will result. As a consequence the engineer, knowing just what results will be obtained, will have more confidence in the brake and his own ability, and the results will be apparent, both in the schedule and power consumed.

The problems of installation, operation and manipulation, however, are infinite and the human equation is perhaps more of a factor than in any other mechanical science, yet I venture to say that many railroad officials give more consideration to the color of the paint used on the rolling stock than to the problems enumerated above; paint is sometimes looked upon as at-

tractive and the brake often as a necessary evil; all of which proves that a man cannot KNOW anything about that which he has no conception of, for, aside from any consideration of the safety feature, there are probably few investments that a railroad manager can make that will return as large a dividend as a good brake, properly installed and operated.

## Combined Drifting and Relief Valve

By F. ROESCH, Master Mechanic El Paso & Southwestern System

Herewith is an illustration of an automatic drifting and relief valve designed and patented by J. F. Miller, an employe of this railway.

It is generally conceded that the principal trouble in connection with superheated steam is due to carbonization of the oil when the throttle is closed, due to the cylinder walls being heated above the flash point of the oil, and consequently at the instant that steam is shut off and air drawn into the cylinders, either through the relief valve or the nozzle, the oxygen in the air combines with the combustible matter in the oil causing same to flash or burn. Quite a number of different devices have been tried with a view to overcoming this carbonization, the best known being the drifting throttle. All of these devices, however, depend more or less on the man operating same, and as the human element is not infallible the results obtained are not always the results desired.

In the drifting and relief valve herein illustrated, the human element is not taken into consideration, its operation being absolutely automatic. It will be noted that the drifting valve is combined with the ordinary form of relief valve. Through its operation steam is admitted at the opening marked "A." When the engine is moving, the piston "B" drops down, thereby closing the openings in the relief valve for the admission of air and opening the port "C" for the admission of steam, consequently when the throttle is closed no outside air can be admitted to the cylinder, but instead steam immediately flows in, thereby preventing any carbonization.

When the engine is standing a small amount of steam is admitted under the piston, forcing it downwards, so that any steam in the cylinders is free to escape through the openings. The device combines with it an important safety feature, in that if the throttle should be leaking the relief valve can be manually forced to an open position, thereby preventing the accumulation of pressure in the cylinders. This safety feature is also valuable for engines standing in the roundhouse, in that the relief valve will be held off its seat so that engine cannot be moved

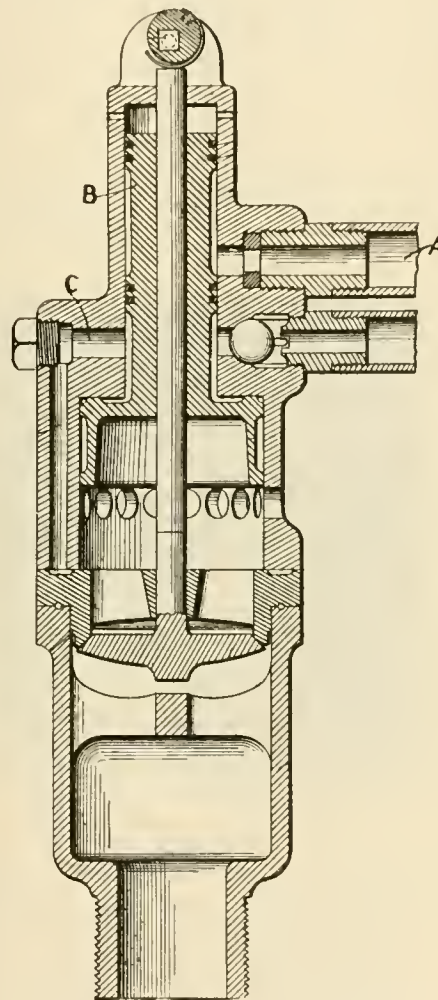

SECTION OF COMBINED DRIFTING AND RELIEF VALVE.

through accidental or intentional handling until the safety feature has been disengaged.

### A Plea for the Railroad Shop Men.

By T. BROWN, SHOP SUPT., NEW YORK.

An editorial published in the April issue of RAILWAY AND LOCOMOTIVE ENGINEERING on the subject of "The Clamor for Shorter Hours," has been widely discussed among railway men, the consensus of opinion being that the shop men have found a real champion in the most popular and the most independent railway periodical. You will pardon me, however,

in stating my opinion that I think the article might have gone a step further and insisted on the necessity of giving some attention to the shop men first.

From the standpoint of a shopman with years of experience and close personal touch with the men who work in the train service as well as those in the shops, why should the lordly trainmen now receive another wage increase without first considering the men in the shops?

The trainmen represent about 20 per cent. of all railway employes. Before considering giving them more, let us analyze the situation a little. The official report of the Commerce Commission shows that the actual annual earnings of men in the train service, who constitute 18 per cent. of the total number of railway employes, are as follows: Engineers, \$1,760; conductors, \$1,520; firemen, \$1,030; trainmen, \$1,020; average of all men in the train service, \$1,240, and the average earnings of all other employes (including the officers) and who constitute 82 per cent. of those in the employ of railroads, is the princely sum of \$700 per year.

This surely shows that the train service men are now receiving their share and an abundant one. Should they be considered again for increase wage? Is it because they can enforce their demands through their organizations, or are they men of such marked skill and intelligence in comparison with the men in other departments of the railroads?

The average engineer or conductor now earns as much as two machinists or two blacksmiths in the shops, and can anyone say that the service they give to the railroads is worthy of this difference in pay? Is it because running a locomotive requires more skill, more judgment, more intelligence than what is required of the mechanic in the shops? The shop mechanic must spend years acquiring the knowledge and skill to enable him to demand mechanics' wages. The wonderful mysteries of the locomotive engineers' job may be learned in a few months by the same man who must work years in shop before receiving in wage about one-half of what the engineer is paid, and the pity of it is he wants more, more.

It is not so much a question of whether the trainmen are now being paid what they are worth, but are they not now receiving so much more than the other em-

ployes in the railroad service? Shouldn't the other 80 per cent. be given some consideration first? The other 80 per cent. do not seem to have anyone to plead their cause, the general public knows little about the shop men. Those in the train service have managed to air their grievances before the public's gaze, and as a logical result many people lose sight of the fact that they have been interesting themselves in only a small per cent. of the men in railway service and that this small number are now highly paid for their service in comparison with what the multitude are receiving.

Let us analyze a little further into this subject. Statistics show that the average engineer or conductor now earns more than two station agents, not agents in charge of small town stations, but two of those in charge of important stations in fair size cities. Is the calibre of men required to represent a railroad in an important station so much inferior to those that are now filling the jobs of engineman and conductor, and are the agent's hours short or has he an easy berth? Still further—compare the railway shop foreman of today; the kind of man the railroads require for a position of this kind must be one of exemplary habits, of sterling quality, absolutely dependable as he has the handling of large sums of money spent by the roads to maintain their equipment. He must be, and is, a far superior man in every way than the man who runs the locomotive, and how does his financial remuneration compare? He receives on the average about 75 per cent. of what is paid the average engineman, and his hours are long, his responsibilities many.

It is not contended that there should be a big wage increase given to the shop men at this time, as the roads can hardly bear their present burdens. It is contended that the trainmen are now getting the cream and before giving them more, that the whole subject of railway employes' pay be looked into carefully, as they all must be paid from the same pocketbook.

#### Small Hand Lubricator.

By F. W. BENTLEY, JR., MISSOURI VALLEY, IA.

Under a great many conditions which necessitate the peculiar location and running of steam piping, it is impossible to conveniently locate and use a hydrostatic lubricator for the engine, and in some instances a force-feed lubricator is all that can be utilized for the purpose. Where the question of expense is involved in the purchase or local manufacture of one, some peculiar arrangements are often found in operation. The sketch and photograph show the design of one utilized in connection with a steam lead running close to a

roof, where the use or location of a hydrostatic device would have been an impossibility.

The valves and seats of the intake

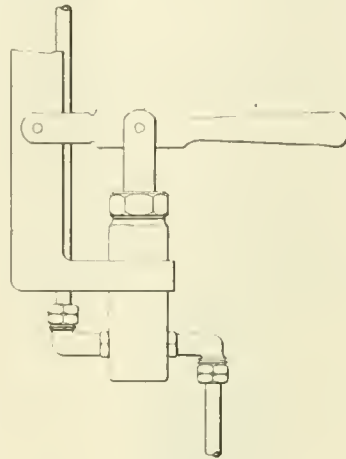

HAND LUBRICATOR.

and discharge openings were made of No. 26 gauge pipe Ls, the same being incidentally a part of the Wab G-6 automatic

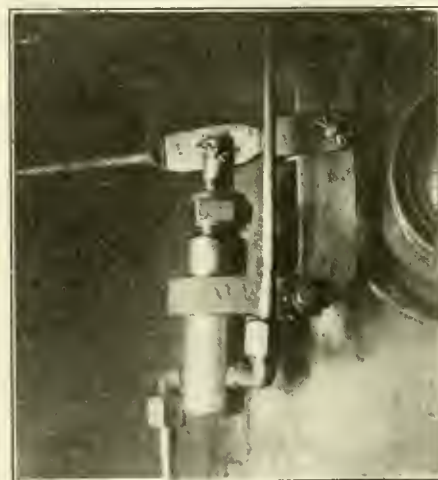

LUBRICATOR IN POSITION

brake valve. Two steel balls answered the purpose of valves, the cone of the joint collar being turned out to afford

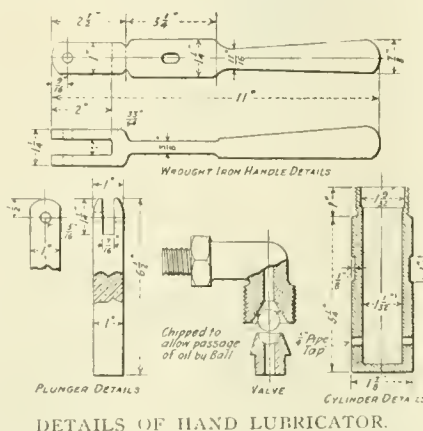

DETAILS OF HAND LUBRICATOR.

a lift recess for them. The packing nut of the ram or plunger was made of an old gauge glass nut.

Under circumstances necessitating the

use of a simple device of this kind, and such are very frequent, a locally made arrangement is often superior to a purchased article, because of the fact that conditions are often not overcome by standard manufactured devices no matter how practical for other engine and piping arrangements.

#### Fitting a Cylinder Key.

By J. J. SMITH, ROCHESTER, N. Y.

The Old Vet watched the Carpenter making a templet for a cylinder key, and as he had seen the Carpenter doing the same thing several times in the course of two weeks, his curiosity got the better of him and he asked how often a key had to be fitted for that particular engine.

"Well," said the Carpenter, with a mild kind of a cuss word, "this is the eighth templet I have made in the past ten days, and I don't believe the keys have been made according to the templets."

"Well, Daniel," said the Old Vet, "you may not have the cylinder back against the frame in good shape; suppose we try it. We will place the engine on this side on the top quarter and give her some steam and see what the result will be."

So the Old Vet got up on the engine, placed the left side on the top quarter, set the brake, and opened the throttle. There was a hard knock and the Carpenter let a yell out that could have been heard half way around the house. The Old Vet got down and with a smile said, "Well, what's the matter, Daniel?"

The Carpenter said, "When you gave her steam you pulled the cylinder back on the frame about an eighth of an inch."

Said the Old Vet, "That is why your cylinder keys have not held. Your templet was just that eighth of an inch small, and the key could not help working out when the engine started working hard. If we place the engine on the top quarter on the side where the key is missing, and place the reverse lever in the front corner, set the brake and give her steam, we are bound to pull the cylinder back in place for we are putting a great pressure between the back cylinder head and the piston, and as the piston cannot move on account of the brake being set, the cylinder will have to move on the frame if there is any slack.

"Now don't forget that, will you Daniel? It beats a jack or wedge all hollow for getting the cylinder back in the proper place."

#### Extension Fronts of the Cleveland & Pittsburgh.

By C. H. CARUTHERS, YEADON, PA.

During a brief visit to Pittsburgh last autumn I was, through the courtesy of an official of the Pennsylvania Lines, afforded the privilege of examining some of the

old Annual Reports of the Cleveland & Pittsburgh Railroad. In many of these I found the pages devoted to locomotives exceedingly interesting because of the minute detail of repairs, etc., and something that surprised me was during two successive years of the early '60s, there was appended to the mention of almost every engine, the statement, "extension front taken off."

Careful research in previous reports failed to show any mention of these "fronts" having been attached, and it has occurred to me that some of your older readers might be able to furnish something of interest in regard to them.

The company had about 60 engines at the time and the reports referred to, indicate that most of the 60 were fitted with them.

### A Tower Man on the Eight Hour Question.

BY M. P. ROGERS, WESTBORO, MASS.

In the May number of RAILWAY AND LOCOMOTIVE ENGINEERING I notice the letter written by Mr. M. H. Gray, of Savannah, Ga., regarding the eight-hour day for trainmen. Mr. Gray seems to be laboring under the delusion that the eight-hour day for trainmen would be like flowers wasting their perfume on a desert air.

There are many sides to this question and fear he has seen only the small side sometimes viewed by a few of the older engineers who have little or no feeling for the trainmen in general.

We must admit the trainman has little to do while a train is running smoothly along between stops, but what fair-minded man can envy them shorter hours and an increase in pay when they have to work ten hours a day on a switcher in a driving sleet or rain storm that freezes as it falls, forming a skating rink on the box cars.

As to the engineer stopping a 45 or 50-car train for them to get on, that is Safety First and should be done for the prevention of injury to a fellow being; it gives the engineer very little trouble to shut off steam and give the air valve a twist, and most railroad men have seen too many injured and killed to begrudge anyone a little extra effort to insure safety.

He cannot see why the trainmen want shorter hours, yet he thinks sixteen hours as limited by the hours-of-service law unreasonably long. In the case mentioned, where the engineer got cold and wet because he was obliged to sidetrack his train and go back to a wreck, this was an emergency where the officials' judgment was faulty and could be much more satisfactorily settled through the engineers' grievance committee than by a confidential chat with an office-seeking politician.

"Why this grand consolidation of labor?" Every broad and fair-minded man

of today, whether employer or employee, knows and admits that the only way the laboring class can get or expect to get better conditions is through organized labor. Did not the United States committee on industrial relations advise disconnected labor to organize as a means of obtaining better conditions?

If each department of labor is to make the effort singly it would be the same as if one man in a shop went to the foreman and asked for an increase in pay for himself. As there is strength in organized labor, so there is greater strength in organizations combined.

There have been no strikes of organized labor on the railroads only as a last resort, neither have railroad men refused to arbitrate; all cases settled by arbitration have brought benefits to the employees and the public has been much surprised by the working conditions brought to light by the boards of arbitration.

After all I am not a trainman, only an opp. in a lone tower, but have a desire to look on both sides.

### Graphite in Valve Chambers and Cylinders.

BY C. B. FLINT, NEW YORK.

The article in the May issue of RAILWAY AND LOCOMOTIVE ENGINEERING, as well as the question and answer in the April issue of the same paper, on the subject of graphite as a lubricant, must be interesting to all who have given any study to this unique mineral.

Mr. Burnside's reference to the necessity of using oil or grease with the graphite is particularly interesting. Covering a period of several years, there have been different devices brought forward to feed a mixture of graphite and oil or graphite and grease. As the article referred to so clearly points out, dry graphite alone in the valves and cylinders is of little value, as there is nothing to catch and hold it; consequently the most of it either goes out with the exhaust or accumulates in one spot, usually on the piston head. The difficulty has been to feed graphite and oil with regularity in steady amounts, and at the same time not clog the ports.

Mr. M. C. M. Hatch, Superintendent of Fuel Service of the Delaware, Lackawanna & Western, recently described a regular and positive method of feeding dry flake graphite, not mixed with oil, but in conjunction with it. The device that he mentions, introduces a minute quantity of graphite dry, with the steam, with each movement of the valve stem. The oil is fed separately, as in usual practice, and as it breaks up in the valves and cylinders and flies to the walls, it catches some of the graphite particles. By this method of feeding, the particles of graphite are mixed with the oil after entering the cylinders and valves, instead

of before, presumably following the same course in the cylinders as the particles of oil. There is no danger of combining in lumps. The feed of both the oil and the graphite is separate and positive, each being an auxiliary of the other.

Mr. Burnside's description of the function of graphite is especially apt. It is beginning to be generally admitted that graphite is not a lubricant per se, but that it prepares the metals for lubrication.

### Old Inventions in New Forms.

Men who pay close attention to inventions are aware that precisely the same kind of mechanical device is frequently produced by different inventors about the same time. Old devices that have become obsolete and forgotten are frequently turning up as new inventions.

The most striking instance of this kind came to my notice several years ago when a Turkish journal gave particulars of a discovery made by a party of engineers while making excavations below the citadel found a wrought iron breech-loading cannon which must have been buried at least 300 years. The breech mechanism is almost identical with that used in the most modern form of Krupp guns.

### Height of Work for Filing.

For filing general work, the top of the vise should be placed so as to be level with the elbow of the workman. If the work to be filed is small and delicate, the vise should be higher, not only that the workman may more closely scrutinize the work, but that he may be able to stand more erect. If the work to be filed is heavy and massive, requiring great muscular effort, its surface should be below the elbow joint, as the operator stands further from his work, as in this class of work it is desirable to throw the weight of the body upon the file, to make it penetrate. It will, therefore, readily be seen that in fixing the height of the vise the nature of the work and the stature of the operator should be considered, if it is deemed necessary to apply the principle correctly.

### To Drill Chilled Cast Iron

To drill chilled cast iron first draw the chill. This is done by laying the piece on the forge, covering the spot to be chilled with sulphur, and working the bellows slowly until the sulphur is burned off. Then proceed with the drilling.

### Expansion of Tubes.

The expansion of metal is: For 100 feet in length by an increase of 100 degs. Fahr., cast iron, .74 in.; wrought iron, .86 in.; brass, 1.23 ins.; copper, 1.28 ins., and lead, 1.91 ins.

## Powerful Consolidation Locomotives for the Lake Superior & Ishpeming Railway

Three large Consolidation type locomotives, developing a tractive force of 55,900 pounds, have recently been built for the Lake Superior & Ishpeming Railway by the Baldwin Locomotive Works. These locomotives will be used in the ore business, their most difficult duty being to haul trains of empty steel cars up a grade of 1.63 per cent., combined with curves of 5 degrees. The question as to whether Consolidation or Mikado type locomotives should be built for this service, was carefully considered; and it was decided that, as the run is made at comparatively slow speed, the Consolidation type would be fully capable of meeting requirements. Furthermore, the Consolidation could be designed with a total wheel-base, of engine and tender, to suit the turntables, which have a length of 65 feet. A fourth locomotive, similar in all respects to

jector check is placed on the top center line, and the seam on the first ring is welded on either side of the check hole, and is also welded at the ends. The front end of the firebox crown is supported on three rows of Baldwin expansion stays.

The boiler is of unusually high capacity for a Consolidation engine. It contains a 45-element superheater, which provides a heating surface of 844 square feet; and the total equivalent heating surface, assuming each square foot of superheating surface as equivalent to  $1\frac{1}{2}$  square feet of water heating surface, is 4,909 square feet.

The cylinder and steam chests are lined with bushings of Hunt-Spiller gun iron, and the same material is used for the piston and valve packing rings. The Nathan automatic vacuum breaker is applied. The valve motion is of the Baker type, and

These locomotives rank among the largest Consolidation engines thus far constructed, and represent the maximum capacity obtainable in this type with the weight and clearance limitations imposed.

The general dimensions of these locomotives are as follows:

Gauge, 4 ft.  $8\frac{1}{2}$  ins.

Cylinders, 26 ins. by 30 ins.

Valves, piston, 14 ins. diam.

Boiler—Type, straight; diameter, 88 ins.; thickness of sheets,  $15/16$  ins.; working pressure, 185 lbs.; fuel, soft coal; staying, radial.

Firebox—Material, steel; length,  $108\frac{7}{8}$  ins.; width,  $78\frac{1}{4}$  ins.; depth, front, 84 ins.; back,  $66\frac{1}{2}$  ins.; thickness of sheets, sides,  $\frac{3}{8}$  in.; back,  $\frac{3}{8}$  in.; crown,  $7/16$  in.; tube,  $\frac{1}{2}$  in.

Water Space—Front, 5 ins.; sides,  $4\frac{1}{2}$  ins.; back,  $4\frac{1}{2}$  ins.

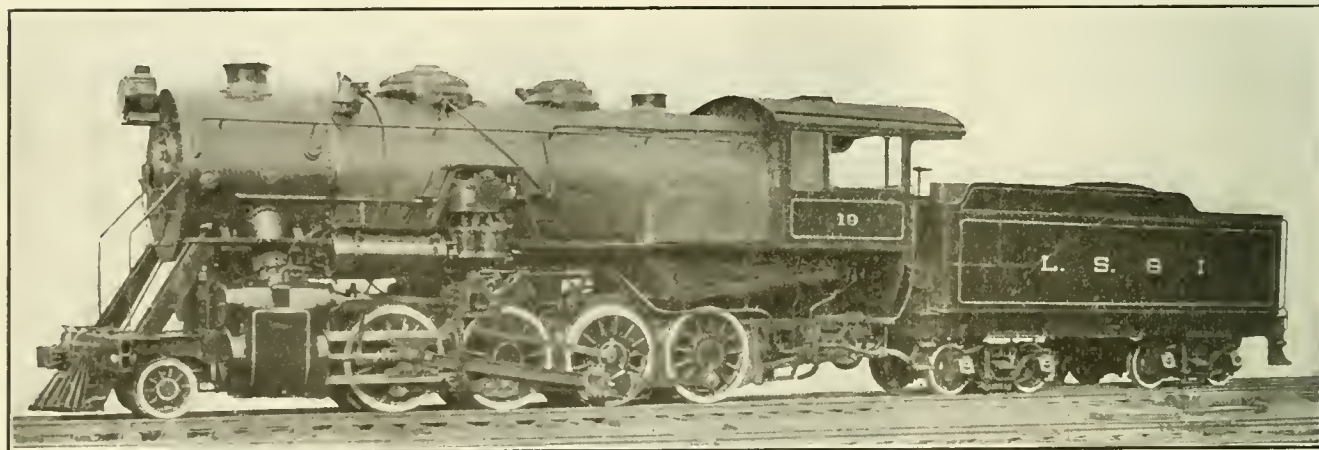

2-8-0 TYPE LOCOMOTIVES FOR THE LAKE SUPERIOR & ISHPEMING RAILWAY.

W. H. Richmond, Master Mechanic.

Baldwin Locomotive Works, Builders.

those referred to above, has been built for the Munising, Marquette & South-eastern Railway.

The boiler used in this design is of the straight top type, with sloping roof, throat and back-head. The center line is placed 10 feet 4 inches above the rail, and by sloping the mud-ring toward the front, there is room for a throat  $199/16$  inches deep. The furnace contains a sectional arch, supported on four water-tubes. The dome is of pressed steel, measuring 33 inches in diameter and 12 inches in height. It contains a throttle valve of the improved Rushton type, with drifting valve. The vertical throttle pipe is flattened in cross-section, and placed sufficiently far forward in the dome to enable a man to enter the boiler without dismantling the throttle valve and its connections. The longitudinal boiler seams have a strength equal to 90 per cent. of the solid plate. The seam on the dome ring is welded throughout its length on either side of the dome opening. The in-

the gears are controlled by the Ragonnet power reverse mechanism which, in the present case, can be operated by either air or steam. The valve motion bearers are supported on the guide yoke. The cross-head link is attached directly to the cross-head wrist pin, thus saving weight and simplifying the design.

Each main frame is cast in one piece with a single front rail, and has a width throughout of  $5\frac{1}{2}$  inches. The transverse frame braces include a large steel casting which supports the front end of the firebox, and is extended forward to brace the main driving pedestals. The brake cylinders are supported on the main frames, just forward of the leading driving pedestals. The brake shaft is fulcrumed on two steel castings which are bolted to the frames under the cylinder saddle.

The tender frame longitudinal sills consist of 13-inch steel channels. The tank is of the water bottom type, with capacity for 8,500 gallons of water and 13 tons of coal.

Tubes—Diameter,  $5\frac{3}{8}$  ins. by 2 ins.; material,  $5\frac{3}{8}$ -in. steel; 2-in. iron; thickness,  $5\frac{3}{8}$ -in. No. 9 W. G.; 2-in. No. 11 W. G.; number,  $5\frac{3}{8}$  ins., 45; 2 ins., 300; length, 15 ft. 6 ins.

Heating Surface—Firebox, 216 sq. ft.; tubes, 3,398 sq. ft.; firebrick tubes, 29 sq. ft.; total 3,643 sq. ft.; superheater, 844 sq. ft.; grate, area, 58.7 sq. ft.

Driving Wheels—Diameter, outside, 57 ins.; center, 50 ins.; journals, main, 11 ins. by 13 ins.; others, 11 ins. by 13 ins.

Engine Truck Wheels—Diameter, front, 30 ins.; journals,  $6\frac{1}{2}$  ins. by 12 ins.

Wheel Base—Driving, 16 ft.; rigid, 16 ft.; total engine, 26 ft.; total engine and tender, 60 ft.  $11\frac{1}{2}$  ins.

Weight Estimated—On driving wheels, 238,000 lbs.; on truck, front, 30,000 lbs.; total engine, 268,000 lbs.; total engine and tender, 425,000 lbs.

Tender—Wheels, number, 8; diameter, 33 ins.; journals, 6 ins. by 11 ins.; tank capacity, 8,500 gals.; fuel capacity, 13 tons; service, freight.

# New Type of Gondola Car for the Pennsylvania

## Two Thousand All-Steel Cars of Great Capacity

Recently the Pennsylvania Railroad Company has had a number of gondola cars built which, on account of their design, are proving very useful and desirable. The special features of these cars are the low distance from rail to top of floor, the great inside length, together with the high carrying capacity.

The cars are especially suitable for heavy freight, the marked capacity being 140,000 pounds and provision, of course, is made for the usual ten per cent. overload. The design is such that heavy concentrated loads can be taken care of. There are two heavy cross beams in the underframe, designed to make the side girders and center sills work together, irrespective of where the load is placed in the car or on the top sides of car. The height of sides are only 3 feet and the top of sides are reinforced with special heavy bulb angles, measuring  $5 \times 4\frac{1}{2} \times 1\frac{1}{2} \times 7/16$  inches. Four small hoppers are pro-

vided in the floor, equipped with two doors each. The doors are operated in multiples of four, with either the Lind or Simonton door-operating device. The distance from rail to top of floor is only 3 feet  $4\frac{3}{4}$  inches, which is a very good condition in keeping down the height from rail to center of gravity of loaded car where excessive height has often been the cause of derailment. The inside length is 46 feet  $2\frac{1}{2}$  inches, which is very desirable for loading long material or two lengths of light short material, such as pipe running up to approximately 23 feet in length. The insides of sides are equipped with collapsible stake pockets so that they are out of the way when not in use and, therefore, are less liable of being damaged by the lading. The design of car is simple and durable, pressed steel being used almost throughout, as it is found that consistent with strength and weight it is more economical to resort to pressed steel than to adhere to standard structural shapes.

Some structural shapes are incorporated where they can be used to advantage, but such items as center sills, bolster diaphragms, floor beams, end sills, end braces, side stakes, hopper sheets, drop doors, etc., are made of shapes pressed out of steel plates. The plates forming the floor, side and end sheets, doors, hopper sheets and most of the floor beams are made of  $\frac{1}{4}$ -inch material. The center sills are 24 inches deep, made from a  $7/16$ -inch plate, flanged top and bottom, extending from end sill to end sill and are reinforced at the top with a  $\frac{3}{8}$ -inch plate and at the bottom with a  $4 \times 4 \times \frac{3}{4}$ -inch angle. The body bolster is made of  $5/16$ -inch plate reinforced at the top and bottom with  $\frac{1}{2}$ -inch plates. The member forming the bottom chord of side girder is made of a  $4 \times 4 \times \frac{5}{8}$ -inch angle, and the side is stiffened and held in place with twelve stakes made from  $5/16$ -inch plates. The length of car from center to

other abstruse philosopher, asserts that the striking difference between the savage and the civilized man arises from the ability of the latter to handle tools. The crowning triumph of the Western mechanic lies in his striking ability to perform work creditably without proper tools. This is not a characteristic of all Western workmen, but it seems to be better developed there than in other sections of this continent. Inferior mechanics are common enough in the West, but they do not generally pass muster as first-class men, for their shortcomings show up conspicuously where they are continually required to do work on their own judgment without direction of gang boss or foreman.

The progress of applied mechanics has a constant tendency to develop special skill on the part of workmen in putting complex machines together and in handling and repairing them after they are in



HEAVY FREIGHT GONDOLA CARS FOR THE PENNSYLVANIA RAILROAD.  
PRESSED STEEL CAR COMPANY, BUILDERS.

vided in the floor, equipped with two doors each. The doors are operated in multiples of four, with either the Lind or Simonton door-operating device. The distance from rail to top of floor is only 3 feet  $4\frac{3}{4}$  inches, which is a very good condition in keeping down the height from rail to center of gravity of loaded car where excessive height has often been the cause of derailment.

The inside length is 46 feet  $2\frac{1}{2}$  inches, which is very desirable for loading long material or two lengths of light short material, such as pipe running up to approximately 23 feet in length. The insides of sides are equipped with collapsible stake pockets so that they are out of the way when not in use and, therefore, are less liable of being damaged by the lading.

The design of car is simple and durable, pressed steel being used almost throughout, as it is found that consistent with strength and weight it is more economical to resort to pressed steel than to adhere to standard structural shapes.

center of couplers is 50 feet and the overall width 10 feet.

The trucks have cast steel side frames which are tied together with pressed steel spring plank channels made of  $9/16$ -inch material. Rolled steel wheels,  $6 \times 11$ -inch journaled open hearth steel axles and pressed steel journal boxes are used. The bolsters are pressed steel bath tub type and the brake beams the M. C. B. No. 2.

Considering the length, capacity and other advantages, the cars have a reasonably low dead weight, averaging approximately 49,500 pounds. The illustration herewith is one of a lot of 2,000 such cars recently completed by the Pressed Steel Car Company.

### Uniformity of Ability.

There is a peculiar elasticity among Western machinists in their methods of performing work without having good facilities for doing it. Carlyle, or some

operation. There are machines and tools in every-day use that require master touches of refined skill at the hands of the fitter, and the exercise of rare ingenuity and judgment must be displayed in detecting causes of derangement after the machines have been in operation. Yet it is quite a hard matter to convince the average machinist that the man who, by thought, investigation and study, has prepared himself to perform the delicate and difficult portions of shop work is rightfully entitled to superior consideration in the form of higher pay than the commonest of common mechanic receives. Men who are otherwise sensible and considerate display no idea of liberality when such a case comes before them. All at once they become zealous for uniformity. When it is applied to the details of machine or rolling stock construction, uniformity is intensely desirable, but the spirit which attempts to reduce men's ability to uniform mediocrity cannot be too strongly opposed.

# Approved Method of Locomotive Boiler Washing

## Details of National Boiler Washing Equipment

The Federal regulation prescribing thirty days as the extreme limit between the periods of locomotive boiler washing is a wise one, but it is frequently found that several washings within this period is necessary according to the degrees of impurities that may prevail in the water in various districts. A thorough washing of the boiler under any condition not only repairs the quality of transmitting heat into the water to make steam, but prolongs the life of the boiler, and also avoids much repairing work that would otherwise be necessary.

The most approved method is to wash the boiler with hot water under steam pressure of at least 100 pounds per square inch. The heated water is more effective. The operation can be accomplished in shorter time and the cost is less. The saving in the amount of water required averages 35 per cent., and the saving in time equally as much. The improvement in the duration of firebox sheets and stays on account of the use of hot water plants in boiler washing is over 30 per cent. The judicious use of soda ash and other chemicals to prevent incrustation in the boilers has doubtless aided in these marked improvements. Occasional complaints are heard that boiler foaming and consequent increase of repairs to valves and packing arise from the use of boiler compounds. Hence the necessity of a careful selection of water purifying chemicals, and the need of an expert analysis of the proper element required.

In this regard the blowing out of boilers while on the road when the treated water has a tendency to foam, is sometimes advisable, and the best results are obtained if the blowing out is proceeded with after the engine has been standing for some time. The western roads, as is well known, encounter greater difficulties in water treatment than elsewhere, but the establishment of water treating plants is rapidly producing good results.

The methods of boiler washing, of course, vary according to the appliances at hand. Generally the boiler should be thoroughly cooled before being washed, except where the improved hot water wash-out systems are installed. The steam should be blown off, and the water retained sufficiently high in the boiler to cover the top of the crown sheet. When cooled to about 90 degrees then the water may be drawn off and the boiler washed. Time may be saved by injecting cold water into the boiler by the use of the injector allowing an escape at the blow-off cock.

After removing all wash-out plugs, the washing should begin at the front end of the crown sheet, directing the stream to

the back of the crown sheet, working towards the back, so that the mud and scale is kept away from the back ends of the flues. The operation should be repeated from the boiler head, revolving the nozzle so as to wash the top of the boiler and radial stays or bolts. The back end of the flues should then be washed, using such curved nozzles as may reach the entire area. The space between the back head and firebox should then be washed directing the nozzle through the holes in the back head. Arch tubes should be thoroughly cleaned at each boiler washing. Their appearance in the firebox side is a reliable indication of their inner condition.

From the holes opposite the crown sheet the side sheets and staybolts may be thoroughly washed down, after which the holes near the check valves may be used with suitable nozzles to reach the upper parts of the barrel of the boiler. In washing the bottom of the barrel of boiler, wash toward the front end, and finish the washing of the barrel from the front opening in bottom of barrel. The mud ring should then be thoroughly cleaned from the various openings and a careful inspection proceeded with. Electric lights encased, with handle of some insulating material, are coming into use in boiler inspection, but in their absence, a rod of 3/16 in. copper or iron may be readily formed with a spiral at one end for holding cotton waste or asbestos, and this soaked with oil may be used. The first inspection will, in all likelihood, reveal portions of scale still adhering to the boiler sheets or flues, and the use of chisels or scrapers may be necessary, and when a thorough cleaning of the boiler has been effected the final inspection should be made by the foreman or some competent man detailed by him for that purpose.

In regard to the improved hot water wash-out systems, it is particularly gratifying to observe that many of the new roundhouses are being fitted with appliances calculated not only to keep the boilers clean, but what is also of much importance to do the work in much shorter time, and as we have already stated, at less expense than formerly. Among others the appliance as perfected by the National Boiler Washing Company are particularly noteworthy, and it is universally conceded that where it has been applied it pays for the cost of installation in a very short time. The accompanying drawing will be of interest as showing in detail a general outline of the appliance, and the description that is appended will repay those who are desirous of keeping abreast of the most

advanced methods of locomotive boiler washing of our time.

Beginning with the locomotive in the right lower corner of the illustration it may be stated that the steam and water are blown out of the locomotive through the blow-off line between the pits and through the main blow-out line, which extends around the entire roundhouse and then into the filter A. The steam and water then strike a baffle plate, and the steam is separated from the water. The steam then rises from filter A, and passes through blow-out steam pipe No. 4 into open heater B.

It will be noted that the steam and water passing to filter A pass flop valve No. 34, the pressure opening flop valve No. 34, which is connected to fresh water valve No. 31. This admits fresh water to open heater B, during the time that the engine is being blown off. The steam entering the open heater B heats the cold water automatically, just as an injector heats water from a tank, and the water is admitted in sufficient quantity to refill the same boiler from which the steam and hot water are being blown. The heated water flows from open heater B, through a pipe, No. 38, to storage tank F, for filling water.

A thermostat, No. 43, is placed in storage tank F and controls live steam valve No. 44. This valve is open when the temperature in the tank is below any desired temperature, preferably 170 degrees F. At this point the thermostat operates and closes the live steam valve, thus automatically maintaining water at 170 degrees F.

This valve is seldom opened, as the steam blown off from the boilers will maintain the proper temperature.

Flat No. 39 and valve No. 42 are for the purpose of controlling the admission of fresh water to the filling water tank when the level of the water falls below a certain point. In this manner there is always a minimum amount of water for filling purposes.

The hot water from the filling tank F is pumped by filling pump G, and is discharged from filling line No. 48, which extends around the engine house and then into filling line drop pipes No. 49 between the pits. On the ends of the drop pipes are placed heavy pressure gate valves to which a hose can be connected for filling the boilers through blow-off cocks. The water from filter A passes through the perforated cone shaped filter No. 54, and through filtering material into pipe No. 10 and flows into washout water reservoir D. By this means of purifica-



tion and storage much waste heat blown out of locomotives is saved.

The temperature of the water direct from the washout tank is about 185 degrees F. As this is too hot to be safely handled the temperature is reduced and controlled by a cold water pipe line, No. 12, which is connected to a hot water pipe line, No. 11. A tempering valve, No. 13, is placed in cold water line. This valve is actuated by a

tion is made, as we have already stated, from the blow-off cock No. 55 to blow-off drop pipes No. 56. The blowing out of the boiler occupies about 30 minutes. The capacity of the filling water reservoir is about 10,000 gallons. The washout reservoir is nearly as large. The pumps are brass-fitted duplex, equipped with governors and lubricators. The washout pump has sufficient capacity to wash three boilers at once and maintain a pressure approaching 100 pounds.

The reports agree that in the item of washing out the boiler under the old system 3½ hours were consumed, while the average time under the improved system that we have briefly described is two hours. The amount of water used under

frequently receive requests for copies of RAILWAY AND LOCOMOTIVE ENGINEERING to replace lost copies, the women of the families protesting that they read the paper regularly. We know that the women of our household are remarkably quick to discover the loss when a copy is missing. Through all classes of railway employees, from the verdant brakeman beginning to run extras to the general manager, all the men and officials pride themselves in knowing something not altogether elementary about the locomotive.

The locomotive stands out a prominent figure in railway operating and the intelligent portion of the employees try to comprehend the principles of its operation, and nearly all trainmen can tell the leading dimensions of many engines. Owing

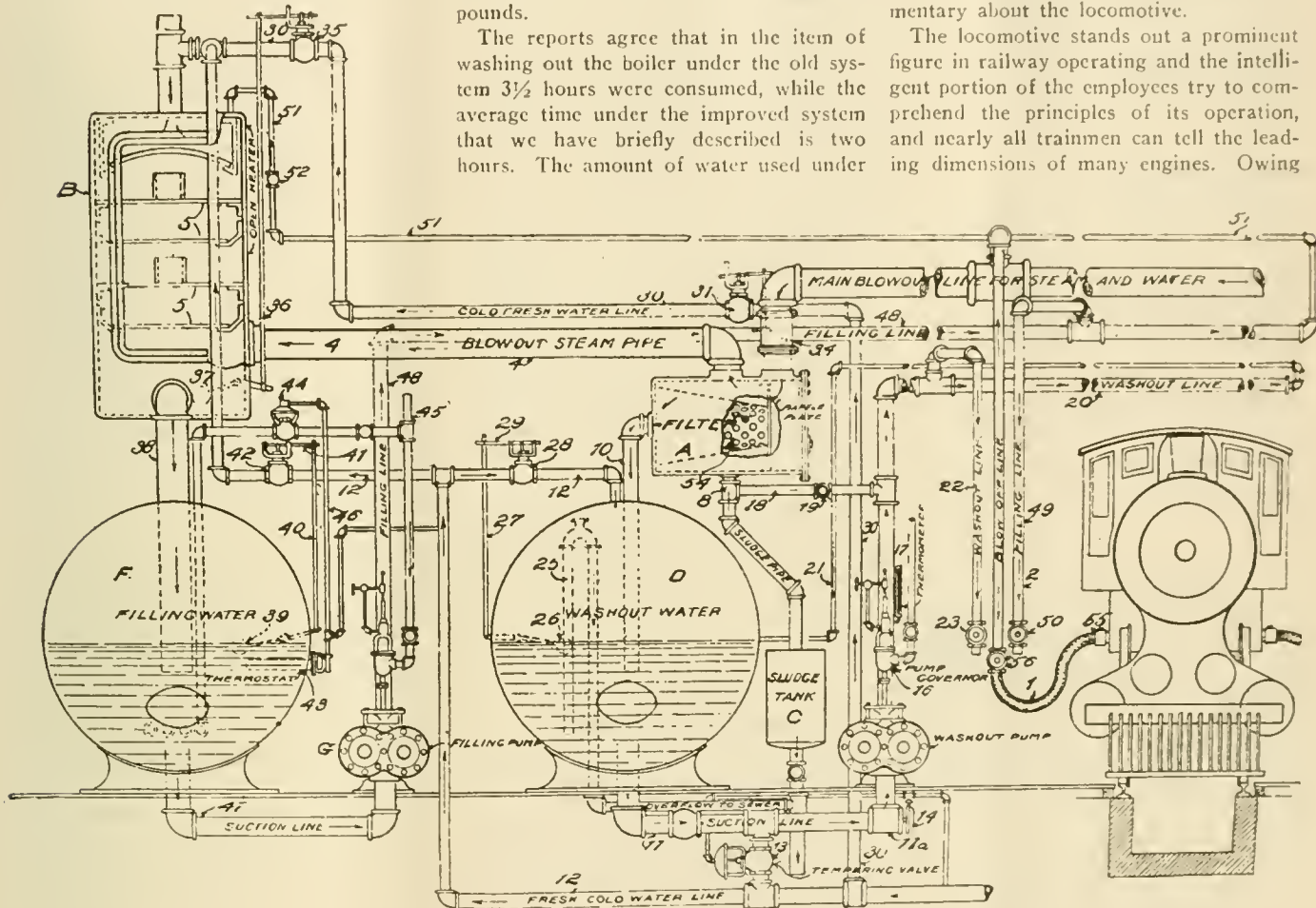

NATIONAL BOILER WASHING EQUIPMENT.

thermostat, No. 14, inserted in tee No. 11A in section line No. 11. A positive temperature of the washout water is maintained. The water is discharged from the washout pump through washout line No. 20, which also extends completely around the engine house and through drop pipes No. 22 at the side of the pits.

Leading from filter A is a sludge pipe which is connected with sludge tank C, and all sludge and scale blown into filter A drops into the tank C, from which it can be readily washed into the sewer. Circulating pipes extend from the ends of the washout and filling pipes back to the reservoirs. Through these pipes, Nos. 51 and 21, a constant circulation of washout and filling water is maintained.

For blowing out the boiler, connec-

tion the old system was 2,000 gallons, the new method only requiring little over 1,000 gallons. In the item of firing up a certain class of engines 2,200 pounds of coal was used as against 1,500 pounds under the new system.

It may be added that the maintenance of the temperature of the boiler at a degree of heat calculated to avoid the distorting strains incident to rapid heating and cooling is an item which, while it cannot be exactly estimated, is one that will readily enter into the minds of the railway men of experience as one of much importance in the repairing and renewing of certain parts of locomotive boilers.

**Interest in the Locomotive.**

It is curious to observe how interested all classes of railway people are about anything relating to the locomotive. We

to this sentiment nearly all railway journals like to publish locomotive articles, and find that no class of matter is so universally read.

**Belt Stretching.**

A mistaken belief prevails among many mechanics that the best belts are those that have all the stretch taken out by the maker. To do this the manufacturer must subject the leather to a stretching process so violent and severe that all the life is taken out of it, and the belts are robbed of what ought to be a leading characteristic—durability.

The belt when driving machinery is stretched generally, not suddenly or violently, and for this reason the stretching is less injurious to it than when it goes through the quick process of the maker.

# Railway Engineering

AND Locomotive

A Practical Journal of Motive Power, Rolling Stock and Appliances.

Published Monthly by

**ANGUS SINCLAIR CO.**

114 Liberty St., New York.

Telephone, 746 Rector.

Cable Address, "Locong," N. Y.

Glasgow, "Locoauto."

**Business Department:**

ANGUS SINCLAIR, D. E., Pres. and Treas.

JAMES KENNEDY, Vice-Pres.

HARRY A. KENNEY, Secy. and Gen. Mgr.

**Editorial Department:**

ANGUS SINCLAIR, D. E., Editor.

JAMES KENNEDY, Managing Editor.

GEO. W. KIEHM, Associate Editor.

**London Representative:**

THE LOCOMOTIVE PUBLISHING CO., Ltd.,

8 Ameer Corner, Paternoster Row, London, E. C.

**Glasgow Representative:**

A. F. SINCLAIR, 15 Manor Road, Bellahouston,

Glasgow.

**SUBSCRIPTION PRICE**

\$2.00 per year, \$1.00 for six months, postage paid in the United States, Canada and Mexico. For other parts of the world, \$2.50, or ten shillings. Single copies, 20 cents. Remit by Express Money Order, Draft, Post Office Order or Registered Letter.

Mailing address can be changed as often as necessary—always give old and new address, and if you subscribe in a club, state the name of the agent.

Please give prompt notice when your paper fails to reach you regularly.

Entered at the Post Office, New York, as Second-class Mail Matter.

**Saving Work on Locomotive Repairs.**

It took locomotive builders a long time to get in to the practise of making the parts of a locomotive interchangeable with those of other engines of the same class, but they have reached that sensible practise now and it must greatly reduce the cost of repairs. This system renders it a comparatively easy matter to maintain standard lengths and sizes in making repairs in the roundhouse or machine shop.

In the olden time when there were ten or twelve different makers of locomotives it was almost impossible to find two locomotives with parts that were readily interchangeable; but thanks to the Railway Master Mechanics' Association, and to the railroad press, the demand for uniformity of parts has borne valuable results. In 1883 the writer had charge of the locomotives belonging to a system

in the Northwest which had 121 engines built by seven different makers, and those belonging only to one maker were sufficiently near being interchangeable that rods and other parts could be interchanged without fitting. Discussion in favor of interchangeability had been going on for years, but the reforms went very slowly, and the writer did valuable service in pushing the desired change. Desirable as the change has been it has proved difficult to induce shop foremen from altering established forms.

It is a bad practice to alter the length of a spring hanger in order to equalize an engine. When such a change is necessary, the spring is at fault not the hanger. The spring is changeable, its "set" is sometimes more, sometimes less. The hanger is rigid, and does not change. Make up for the weakness of the spring by putting in liners under the gib hanger, and when the spring is full set, take liners out. When hangers are repaired, bring them back to their original lengths. Find out from a new engine what the length should be and make a template or drawing of the same and keep it as standard for the men to work by. When this plan is adopted it saves a great deal of cutting and trying.

The same policy should be adopted with the other parts of a locomotive, such as set screws, nuts, keys, etc. Keep them to standard. By so doing a supply of detail parts can always be kept on hand ready for the emergency that never fails to come.

**Firemen Make Best Engineers.**

The increasing responsibilities thrown upon the locomotive engineer by the never-ending additions to train mechanism, are making most railroad companies strict in examining firemen concerning their knowledge of engine and train mechanism before permitting them to take charge of a locomotive. Conditions are very much changed from the days when a fireman was considered fit for promotion when his turn came, if he knew how to "keep her hot" and could read the time-card. When a man had merely to wait and do his daily work to inherit a change from the scoop to the throttle lever it was quite natural that there should be very little ambition displayed to study into the mysteries of triple valves, valve motion, combustion and other subjects which a good engineer ought to be familiar with. In those days it was only the exceptionally ambitious and inquisitive man who would make himself familiar with the details of train mechanism, and the scientific principle of his business.

It is really for the good of engineers that firemen should understand that an examination has to be passed before they will be permitted to run a locomotive;

but the spirit of emulation, resulting from the new condition, has drawbacks that are troublesome when not properly controlled. The education sentiment infects many young firemen so strongly that they are filled with ambition to become engineers before they learn to perform the work of a good fireman. Men moved in this direction ought to remember that their principal recommendation for promotion is the fact they have given satisfaction as fireman, and done the work in a way to commend them for more important duties. When a man is slovenly and neglectful of the work that falls to him in one position, it is natural that those who control the promotion of men should infer that inferiority in one position would be followed by the same faults in a higher line of work.

The first thing a young fireman ought to devote his mind to is, how to fire so that steam may be kept up. This requires both skill and careful attention, and a young man may make a few trips before he succeeds in doing this important part of his work to the satisfaction of the engineer. Persevering attention will soon make him master of this part of the work; but he should always bear in mind that firing is the most important of his duties, and that usually skill in doing the work will soon give him a much higher reputation than anything he can tell about valve motion. In connection with manipulative skill with the scoop, with the ability to tell what part of the fire is thinnest and how to scatter the coal to even it up, he should study the methods of firing that make steam most easily with the kind of coal used and for the work to be done. When the pointer of the steam gage begins to go back, the inexperienced fireman will be inclined to begin throwing in more coal, to shake the grates, or to use the rake or poker. Before anything is done he should glance at the fire and judge by its looks what is wanted. This can be most successfully done by turning the scoop upside down and holding it inside the door, pointing downwards. This induces a current of air upon the surface of the fire, and enables the eye to take in the condition of the whole burning mass of fuel. There may be white, glaring spots, indicating holes in the fire, which must be covered forthwith; there may be dark portions, due to heavy firing on spots, and they should be broken up by rake or poker—tools, however, that must be used with good judgment or harm will be done. The fire may be even and not too deep, and yet have a dull appearance on the surface; this would indicate that the admission of air was too restricted, and that grates needed shaking. The fireman should be on the watch to see that the tendency of the draft is to burn the fire evenly all over the grate surface. If the action of the exhaust has a ten-

dency to cut the fire at the front or back, the engineer should be told about it, for the draft appliances need to be adjusted.

There is one thing, however, on which a zealous fireman needs to put restraint upon himself, and that is, to keep up a high pressure of steam only when it is needed. The fireman who keeps the safety valves screaming every time steam is shut off, wastes fuel and makes a nuisance with the unnecessary noise.

The secondary duties which a good fireman performs, exercise an important influence on his standing as a good or inferior fireman. He ought to keep a clean cab and do his work systematically, having a place for everything and everything in its place. The popular fireman reaches the engine in good season before starting time, and sees that the fire is in good order, the ashpan clean, that the tank is full of water, the sandbox loaded, the oil cans filled, and that the fire tools are there and in good order. If he does that regularly, keeps his part of the engine clean and does the firing properly, he is in a good way for promotion. After he has acquired these habits and they come natural, he may safely devote his mind to the study of engine and train mechanism.

#### Efficiency.

In psychology the meaning to be given to efficiency is still in dispute. In mechanics it may be described as the ratio of the energy that is got out of a machine to the energy put in. Articles, pamphlets and books come to us, in an endless array, all harping on efficiency. As long as they dwell on mute, insensate things we give them respectful attention. When they touch flesh and blood they are largely misleading, and are unworthy of any serious attention. If the average man is well-treated he will do his best, and angels can do no more. If he is driven beyond his speed, a revulsion sets in, and he becomes discouraged. Yet we have books telling us how a mechanic should stand at his work, how far his feet should be apart, what particular curve his hammer should describe in descending upon the head of a chisel, with the variable angle inevitable on the recoil of the hammer, and the degree of the muscular tension incident to the succeeding blow. Nature is set aside as if the handiwork of the Creator was a deformity, and some self-appointed inquisitor, incapable of doing any real work himself, sets out to find fault with others that can work.

In our experiences in railroad shops, and elsewhere, we have observed these misguided parasites. He generally comes in the shape of some college fledgling full of theories and self-conceit. Some aged relative pulls a stroke on the board of directors and the young bag of wind is appointed as an efficiency expert. Through

his glorified spectacles he sees a grey hair here and there, on the heads of some of the mechanics of whose skill he can know nothing, but they become like spotted leopards in his eyes. They must be replaced. He sees others at the tool-room, waiting a minute or two for a certain tool, and the bright idea flashes upon him that boys can do that. Then there are two men at the grindstone, one waiting until the other is finished, and the vision of saving three minutes flashes upon him in the shape of improved methods. His chief idea seems to be to keep the noses of the toil-worn mechanics on the grindstone. Accomplishment in final results is beyond him. His methods are microscopic. Like a drill sergeant he must get rid of the individuality of the recruits. His success is not visible to the naked eye, but to sustain his mental attitude he must needs blossom into print, and so the pamphlets come on in unbroken succession.

He should take a rest, and give other people a rest, and then he should be induced to take to some other occupation. There must be some place somewhere, that he could fill, but like the boll-weevil or the mosquito, his good qualities are past finding out. His opportunities are great and his abilities are not to be altogether sneezed at. We might pray that he may take a thought and mend, but we are not praying for miracles.

#### Learning the Machinist Trade.

A good deal of misapprehension exists in the minds of boys desirous of learning the machinist trade, or engaged in learning it, about the advantages and disadvantages of certain shops as compared with others. There seems to be an opinion almost universal that the trade as practiced can only be learned in some large manufacturing establishment provided with all modern tools and facilities for doing work. This is a grave mistake, but it undoubtedly prevents many young men desirous of learning the machinist trade from entering some less pretentious shop, through waiting for the opportunity to begin work in one of the larger shops, opportunities that never come round. Not only this, but many boys who enter the smaller shops, work all through their time under the discouraging belief, that in the proper sense they are not learning the trade as it ought to be learned. While many large moderately-equipped shops afford good opportunities for wide-awake boys, alive to their interests, it is beyond much question, a fact that as a rule the small shop—the genuine machine shop—affords better opportunities for the same class of boys. There is a wide difference, and this is generally lost sight of, between learning to use machine tools and learning the machinist trade.

We received some time ago a letter

from a young man in one of the Southern States, in which the writer says that he is learning the machinist trade in a railroad shop which has few of the modern machine tools that he understands are common in Northern shops. In fact that he knows nothing of many tools except what he reads about them in our pages. He doubts that he can learn the trade properly in a shop poorly equipped with good modern tools with which he is expected to do first-class work. In this sentence he gives the best possible reason for remaining to serve out his time for managing to do good work with tools that require a good deal of planning to get good work from is the most valuable kind of experience an apprentice can go through. A man who can execute first-class repairs on locomotives with tools ill suited for the purpose is certainly a first-class machinist.

Being obliged to contrive ways and means as well as do the work, is one of the advantages an apprentice is likely to enjoy in a small shop, and in the future this will generally outweigh the advantages of the use of special tools acquired in the better appointed shop. In fact the use of special tools is something the apprentice in the small shop, where he is required to do good work, need never trouble himself about. He will never need learn to use them. When the opportunity comes he will use them without learning. Learning the machinist trade is learning to do machine work with the tools and appliances at hand, and the best part of it—in fact, about all of it—is in the knowing how to adapt means, good or bad, to an end. It is curious to find a machinist apprentice complaining because he is debarred from using machine tools, for in Scotland the workmen did not consider operating machine tools to be a machinist's work. That was considered the work of a skilled laborer.

Another point upon which mistakes are frequently made, is attaching undue importance to the kind of work done in a machine shop. There is no objection to following one's inclination in this matter when it can be done as well as not, but the real objective point is to learn to shape metals, and in the future it will not make any difference whether the pieces shaped go into a steam locomotive or a car truck.

#### Enterprising Drummers.

The American name of "drummer," given to the personage who in other English speaking countries is called a commercial traveler, conveys the idea that said drummer is not a welcome personage. Yet some people who employ their own travelers for soliciting business have very little civility to offer other people's drummers. Here is what our old friend Chordal once wrote:

The machine drummer deserves recognition. He may be a nuisance sometimes, but it would be hard to get along without him. There is something exasperating in sitting in a panic-stricken shop and having some fellow come in to sell you a supply of oils. You don't want any oil, haven't got any use for oil, and it don't look as though you ever would need any oil. You get rid of him and in comes another fellow to sell waste. You don't want any waste when you don't need oil, and you get rid of this man. Then in comes another oil man. Then another man with oil. You begin to abuse those oil men and ask them if they think you swim in oil. It is a noticeable feature that the less use you have for oil the more men come around trying to sell you oil. From oil it goes to other things and you get tired of the whole genus drummer.

But presently you pack your own grip-sack, and start out on a drumming tour to see if you can't sell something yourself. May be you make gauge cocks for a living. You strike a railway shop, and find a big sign hanging out in front of the master mechanic's office, "No oil wanted here." You go past the sign and hunt up the master mechanic, and congratulate him on the happy thought of having that sign up as you tell him that you will do the same when you get home, and thus guard yourself against the infliction of oil men. Then the master mechanic says that he don't want any gauge cocks either. As you go past the sign at the door you hesitate to look at it for fear it will read differently from what it did when you entered.

There is a certain corporation with a handsome set of offices. Away back through a half dozen intermediate offices is the inner penetralia of the General Manager. The Governor of the State could only get back there by going through certain ceremonious forms. The oil drummer looks neither to the right nor to the left, but makes his first and only bow when he reaches this inner sanctum. The General Manager threw out extra pickets, placed a boy in the outer office, with gates at intermediate railings and signs at doors; but still the drummer bowed before him, and before him only. At last happy thought! The General Manager sets the office boy addressing circulars in his distant quarters and establishes himself at a desk inside the first entrance door. Mr. Drummer now honors him with a nod.

Leaving out of consideration the real drummy-drummer, who never lets you lose sight of the fact that he comes to you to make a sale, and leaving out of consideration the ignoramus who know nothing but the pat tale stuffed into them before they start out, the drummer is a man to be welcomed. He is a traveler who carries the news of the world. He

brings you the latest and the freshest, if you will gossip five minutes with him, and he adds your little mite of news to the store. The drummer who travels with his eyes open, if he has really good sense, should be able to make himself welcome in a large class of machine shops and railroad headquarters offices.

Speaking of drummers, reminds me of a Scotchman who travels in the governor business. This man will give you the latest news in the governor world, and all other lines mechanical, be it good or evil for him. He sees everything that is new fangled in the shops, and knows of their failures and successes. He can give you data and points to help you in your troubles. He may say no word about governors, and loses no trade by his silence.

#### Sparging Inventors.

Men who would not expect for a moment to ask advice from a lawyer or physician without paying for it, seem to forget that the same practice should hold good in mechanical and engineering affairs. Inventors and men who are considering the propriety of investing money in engineering and railroad mechanical enterprises, will walk into the office of some engineering expert engaged in a publishing business, ask questions, make the request for plans or drawings and seek advice that none but an educated engineer would be competent to give, without thinking of paying for the service rendered.

A man who graduates from any of our great technical schools, spends more money, time and effort on obtaining his education, than a lawyer or doctor of medicine does; but somehow many people seeking for the form of information that the trained mechanical engineer alone can give, do not hesitate to ask for such information without paying for it. We take the opportunity to discuss this question, because we believe that many people ask for engineering advice free because they have not become accustomed to consider that a mechanical engineer has as much right to be paid for advice as a lawyer has.

If a competent mechanical engineer was consulted before any machine or patented device was placed upon the market, there would be fewer failures and disappointments, and it would be a good paying investment to pay well for their services in any case.

Men who want to use the brains and training of experts without paying, would often resent the impeachment of "sparging" on anybody. Yet to the engineer whose bread and butter comes from the exercise of his acquired knowledge, these beggars of knowledge free are nothing short of dead beats.

There is another class of men who seem to think that an engineering publication exists for the purpose of doing expert designing for them free of cost. One of this

class wrote once asking for the required horsepower, size of boiler, size of screw and other particulars necessary to drive a boat 30 feet long, ten miles an hour. Now, although we know enough about locomotives and cars to get along, we do not profess to know anything about designing steamers. So we wrote that man saying that if we were in his place, we would employ a competent marine engineer to work out his problem. We received a postal card saying: "The reason you don't answer wright is becoss you don't know, you editors ain't so smart as you pretend."

We have been trying ever since to recover from the shock given in the last phrase.

This is the age of the specialist. An expert mechanic will verify your plans or point out their weak points in a few moments and perhaps save you thousands of dollars; but don't expect his services for nothing or for less than expert work is worth.

#### A New Promoter of Laziness.

An inventive genius has come to the rescue of that class of idlers who are becoming enervated through constitutional fatigue. He has invented and patented a machine for exercising and developing the muscles of the human race. We were always under the impression that a buck saw, vigorously operated, was a tolerably good means of muscle development, but in these days of aesthetic refinement the efficient buck saw has become too vulgar. This new patented machine is a genteel, refined way of getting healthy exercise.

Among the rising members of our codfish aristocracy, anything in the shape of work is becoming unfashionable, and this new invention is intended to conceal work under the cloak of amusement. It consists of a combination of endless chain, crosshead, rods and gearing which a person can operate in an easy reclining position. Instead of walking about to face the bracing breeze, the patron of this machine which is really calculated to develop laziness is expected to take his exercise reclining in the elegance of down and velvet.

#### Keep Experiments Separate.

The greatest obstacle in the way of forming definite conclusions concerning the value of experiments is the fact, that generally more than one experiment is tried at the same time. Hundreds of experiments that count for nothing would have been valuable in advancing both general and specific knowledge, if, between them and others with which they are compared some addition or alteration had been made, the presumed influence upon the result leaving the latter problematical.

# Air Brake Department

## Twenty-Third Annual Convention of the American Air Brake Association Important Papers Presented and Discussed—Election of Officers

The twenty-third annual convention of the Air Brake Association was held at the Hotel Ansley, Atlanta, Ga., beginning May 2, 1916. The convention was called to order by the president, Mr. J. T. Slatery, at 9 a. m., and after a prayer by the Rev. W. R. Hendrix and addresses by the Mayor of Atlanta, Mr. J. G. Woodward; Mr. Fred Houser, secretary of the Atlanta Convention Bureau, and the president of the Air Brake Association, the reading and discussion of papers on technical subjects was taken up.

The first was entitled "Slack Action in Long Passenger Trains, Its Relation to Triple Valves of Different Types and Consequent Results in Handling of Passenger Trains," and was read by Mr. J. A. Burke.

The paper comments upon the slack action effect encountered in modern passenger train handling and points out the difficulties met with in the efforts to control this slack action to the intent that smoother air brake stops may be made. The author considers that troubles incident to operating long passenger trains has increased instead of diminished during the past few years in spite of the consideration the subject of train handling has been given by air brake men and others directly interested in smooth handling of trains. These difficulties have been summed up as follows:

Slack action in any train is produced only by a change in speed between the various cars comprising such trains. The degree of severity of the slack action depends upon the rate of speed at which the slack action takes place and the number and weight of cars involved.

In order for any car in a train to change its speed at a greater rate than other cars, during a brake application, retardation must be set up on such a car at a higher rate than is obtained on other cars connected with it; assuming that the entire train is on practically the same grade, so that the effect of grades is eliminated.

Considering then an ordinary passenger train of from 12 to 15 cars, equipped with P. M. or L. N. equipment throughout, the following conditions obtain in ordinary handling:

(a) The percentage of braking power on the locomotive is lower, considering the total weight of engine and tender, than the braking power on the ordinary passenger car.

(b) Unbraked weight in the forward end of trains tends to increase the shock due to slack action, in the form of jerks, if that weight is brought to a stop sud-

denly, such as might be the case if the slack was pushed back in the train and then jerked out again quickly, and may be produced during ordinary brake operations by shutting off the throttle quickly and in a few seconds applying engine and train brakes somewhat heavily.

(c) Applying the engine brakes and then the train brakes.

(d) Trains with brake conditions that produce effective braking power on the engine and head cars in advance of the rear cars.

(e) Cars in a train having a lower percentage of braking power to their total weight than the balance of cars, due to their being loaded in one case and empty in another.

(f) The severity of any shock produced from the above will depend upon the degree in which any or all of the above mentioned features exist. The number and weight of cars, rate of speed and amount and rate of producing brake cylinder pressure.

Since all of the above conditions do exist in passenger trains, it is possible that severe shocks may be produced in trains of from 10 to 15 cars during brake applications. The conditions having the greatest effect in producing slack action, ordinarily, is that of producing brake cylinder pressure sufficient to set up retardation on the forward cars in a train sufficiently in advance, and in a degree that will cause the train to bunch when an ordinary brake application is started, hence, loaded baggage, mail, express and other load carrying cars that do not maintain the same percentage of braking power, on account of their load, as the other cars on the rear of the train, cause the slack to be pulled out of the train as the brake cylinder pressure is accumulated on the rear cars. This is brought about by small brake cylinder volumes in proportion to auxiliary reservoir volumes, which in many cases is caused by the action of foundation brake gear in connection with automatic slack adjusters.

Cylinder pressure accumulating faster than it should, in proportion to the brake pipe reduction, which causes the head brakes to become effective ahead of the rear brakes, causes the slack to run in as the brake application is started. This condition may produce a collision between the head and rear end of the train at low speeds or cause very severe and damaging jerks at slightly higher speeds.

It is therefore evident that the brake cylinder pressure must rise gradually in order that the slack movement in the

train may be taken care of gradually, unless the speed is very high.

Under the present order of general passenger brake conditions, this must be brought about by the brake pipe reduction being made in light steps and in an increase in the time of making stops. The amount of the initial and succeeding brake pipe reductions, producing brake applications, must therefore be made in proportion to the speed of the train and the number of cars involved.

The ordinary passenger car brake is designed to produce a pre-determined brake cylinder pressure for any given brake pipe reduction, providing the brake cylinder piston travel is eight inches, and that it is possible to produce the eight inches piston travel on a very low cylinder pressure during service applications. It is necessary then to maintain a brake cylinder volume equal to eight inches piston travel on cars, if it is desired to obtain proper brake cylinder pressure, and at the proper rate that the operating mechanism was designed for.

Piston travel shorter than eight inches produces a higher cylinder pressure for any given brake pipe reduction than should be the case, therefore this reduces the time in which the cylinder pressure can be built up, causing the cars to stop more suddenly than desired, and since the severity of shocks depends upon the rate at which the slack runs in the train, and the number and weight of cars and engine, it can be said that this is the predominant cause for shocks occurring in ordinary handling of long passenger trains.

The condition is one that has gradually grown worse since the advent of heavier cars and locomotives, increased power of brake cylinders, higher pressures, etc., without a corresponding increase in foundation brake gear efficiency, as the present type of foundation gear has been the general standard up to within the past year or two.

The differences in operation of type P and type L triple valves is touched upon, also the general effects of increased weights of vehicles, length of trains and present foundation brake gear.

The discussion which followed the reading of the paper brought out very clearly and beyond question the reasons for rough stops with passenger trains and also the only method of procedure that will constitute a remedy, and this will involve the application of new types of foundation brake gear.

Locomotive engineers pointed out the

fact that certain trains could not be handled smoothly regardless as to the manner of brake application employed, shocks were experienced whether the initial reduction was 20 lbs. or 6 lbs.

Mr. Turner explained the entire situation and stated that no matter how proficient an engineer may be in brake manipulation the modern passenger train cannot be stopped smoothly without a sacrifice in time and frequently schedule time. He stated that the triple valve or car brake operating valve was not responsible for the rough handling, as it in itself could do nothing beyond admit compressed air to and exhaust it from the brake cylinder, and while under certain conditions it might admit pressure to the cylinder too rapidly for a smooth stop, it could not be responsible for the effect.

It will be understood that Mr. Turner was not considering a defective triple valve, for obviously the valve in itself would not be responsible for the existing defect, rather the persons who have charge of its maintenance.

He also pointed out that the short piston travel was the primary cause of too rapid a rate of rise in brake cylinder pressure during an application of brakes and that the rough handling incident thereto was no fault of the automatic slack adjuster, and that the engineer could not be responsible for a shock if his initial brake pipe reduction was merely enough to move the car brake operating valves and the subsequent reductions were consistent with the development of brake cylinder pressure at a gradual or slow rate.

He was also emphatic in his denial of the brake manufacturers being at fault in cases of rough stops and charged foundation brake gear of the car with being entirely at fault and preventing the attainment of the features considered essential by the brake manufacturers.

Our readers will understand that Mr. Turner, in speaking of light brake pipe reductions, was considering the braking problem from a viewpoint of smooth train handling and not time saving and made it clear that the brake gear of the car was at fault when a slack adjuster took the brake cylinder piston standing travel up to 4 or 5 inches, thus reducing the brake cylinder volume to a point entirely out of proportion to auxiliary reservoir volume, so that the light brake pipe reduction on short piston travel was more than equal to a heavy reduction on fair travel. He pointed out the effect of a difference in brake cylinder pressure on the cars in a train, showing how a difference in the rate of retardation was set up, and that at a change of speed of one mile per hour between two cars resulted in an impact equal to the weight of the car striking the blow or with seven cars of equal weight the blow would be equal to

seven times the weight of the car at a difference in speed of one mile per hour, and he became so enthused on the subject that he offered to go to the station and in one hour's time arrange the brakes on any train so that the train could be stopped by them without shock and intimated that about all that would be necessary was to let the brake cylinder piston travel out to 10 inches. In order that the reader may not gather the wrong impression, we will again state that Mr. Turner was talking about a stop with the air brake without a shock to the train and not about shortening train stop distances.

It was suggested that a slack adjuster could be removed from a foundation brake arrangement of such a poor design that piston travel would be taken up to 5 inches, but certain members called attention to the fact that an adjuster was a necessity and if not used their through trains would be delayed by making hand adjustments at division terminals, so that the general consensus of opinion was that the only rational remedy for rough handling is an improvement in the foundation brake gear, and several members went so far as to state that the rough handling could not be entirely eliminated save by the clasp brake gear and the electro pneumatic brake system.

Mr. Turner explained very clearly his stand for an improvement, showing how a train was being handled smoothly for several hundred miles and suddenly, without any apparent cause or without the slightest change in methods of brake valve manipulation, shocks and surges would occur on every application and on every succeeding one regardless as to how the brake valve was handled.

The subject was considered of sufficient importance to be continued for further investigation, and a committee consisting of air brake experts of a large number of roads was appointed for this purpose.

The second paper, on the subject of "Best Methods of Educating Apprentices to Give the Railroad Companies Efficient Air Brake Mechanics," was read by Mr. M. E. Hamilton.

This paper brought out the fact that in this age of specialization few railroad companies have made any effort to produce specially trained men to look after the maintenance of the air brake and also states what progress certain roads are making in a direction tending to give apprentices an air brake education.

The author has mapped out a course of work divided up in different periods in which an apprentice could obtain the practical experience with air brakes while educating himself to do air brake work in an efficient manner. The first schedule is for apprentices on locomotive repair work, the second on car work, as follows:

	Months
Repairing hose, angle and cutout cocks, retainers, etc.....	3
Cleaning and repairing triple valves	8
Repairing pumps .....	3
Repairing brake valves and engine equipment .....	4
Lubricators, injectors, headlights...	3
Air brake pipe work.....	2
Rip-track air brake work.....	1
Inspecting trains .....	1
Roundhouse A. B. repairing, inspecting, helper, hostler, etc.....	9
With R. F. E., A. B. instruction car and firing .....	2
<b>Total .....</b>	<b>36</b>
	Months
Dismantling air brake equipment...	1
Repairing hose, angle cocks, etc....	2
General rip-track and air brake repair work .....	10
Cleaning and repairing triple valves	4
On brake cylinders.....	2
Leverage work .....	1
Testing .....	1
Inspecting trains .....	8
Braking on road.....	1
<b>Total .....</b>	<b>30</b>

The question was raised as to whether the expense encountered in a special training for air brake mechanics was justified or whether the returns would be sufficient to reimburse the expenditure, but the air brake men present considered it to be a profitable investment for any railroad company and recited many instances in which untrained men were decidedly of more actual expense than would be met with in educating air brake mechanics.

A paper entitled "Care of Modern Passenger Brake Equipment—Factors Contributing to the Minimum Cost of Maintenance with the Maximum Efficiency" was then read by Mr. C. U. Joy.

The matter was taken up under three headings, Inspection, Yard Testing, and Maintenance.

In inspection Mr. Joy takes the stand that inspectors and repairmen should be given air brake instruction and be required to pass an examination so that they would be qualified to properly perform their duties. In connection with yard testing he assumes that two air brake men with one testing machine can care for 16 trains averaging 8 cars each per day and that the code of test compiled for this purpose by the Westinghouse Air Brake Company is satisfactory in every respect.

Maintenance is divided into three separate sections, valvular mechanism, piping and brake cylinders and mechanical transmission.

Under the heading of valvular mechanism Mr. Joy gives the following:

It has been the practice and rules of

practically all railroads to clean the triple valve every three months and the brake cylinder and slack adjuster every six months. This same practice still continues with the passenger control equipment. The railroad companies have expended large sums to apply this modern equipment to their passenger cars and it is no more than right that they should have a fair return for money invested, particularly if the efficiency of the equipment can be increased. Tests have developed that a PC control valve properly cleaned and lubricated and afforded proper protection from dirt and moisture will remain in service over a year and stand the yard test each day, and also that this same valve will pass the rack test. Such being the case it is reasonable to assume that the efficiency of the valve is increased above what it would be if it were cleaned four times during the year or every three months.

The control valves that were subjected to this test were lubricated as follows:

The slide valves, piston bushings and packing rings were lubricated, sparingly, with dynamo oil, graphite and oil, triple valve oil and a light generator oil.

The cost of removing, cleaning, testing and replacing a control valve is, together with dust collector and strainer, about \$1.53.

All valvular mechanism that fails to pass the yard test should be removed and shopped for repairs and the parts should be thoroughly inspected and gauged and new parts applied where necessary, conforming strictly to standards. The ports and passages in all parts of the valve should be cleaned and blown out and, when it becomes necessary to remove bushings the valves should be shipped to the manufacturer for this class of work. All valves should be tested without lubricant on the internal parts, which gives a good check on the repairs. If the valve passes the code of tests, the men operating the test rack should lubricate the parts sparingly. Valves that do not pass the test should be returned to the repair man with a card attached giving the reason for the valve being rejected, which in turn assists the repair man in making necessary repairs. It has always been our practice at the shop to give each repair man a number which is stamped on the valve that he repairs. The man operating the test rack keeps a record of the numbers and type of valve passing the test and it is submitted to the foreman each day.

Tests have determined that if brake cylinders are properly cleaned and lubricated, particularly if they are equipped with the J. M. expander ring, they will remain in service with a minimum leakage for 18 months.

The cost of cleaning and lubricating the brake cylinders and slack adjusters is about \$1.02, which, added to \$1.53 for

the control valve, gives a total cost for cleaning the entire equipment of \$2.55, the average price of labor being 25½ cents per hour.

Extending the time of cleaning of the control valve to six months and the brake cylinder and slack adjuster to twelve months would mean a saving of 50 per cent. of the present cost of this work, and experience will probably demonstrate that a further saving may be advantageously made along these lines.

Brake cylinders and slack adjusters, when being cleaned and lubricated, must have defective parts renewed and the completed cylinder tested by placing a gauge in the brake cylinder exhaust port of the control valve and noting the amount of leakage, which should not exceed 5 pounds per minute. The slack adjusters should be tested by making a number of service applications to insure the operation of the slack adjuster.

The reader will note that a lengthening of the time of cleaning triple or car brake operating valves is recommended, and rightfully so, as it is generally recognized that the triple valve that has been in service for 3 or 4 months is not the one that gives any trouble; it is usually the one that has been cleaned and lubricated within a period of from 3 to 6 weeks time, and naturally the question of a suitable lubricant was discussed. Those of our readers who have read articles on the subject of triple valve repair work and lubrication in RAILWAY AND LOCOMOTIVE ENGINEERING will take it for granted that any representative of this publication would stand for the elimination of moisture or moist lubricant from car brake operating valves, and as a result Mr. Turner was called upon to explain the reason for recommendations specifying two different kinds of lubricant for a triple valve. He did this to the entire satisfaction of the members, claiming that the use of oil in a triple valve was entirely due to certain railroad men insisting on following long established customs under the assumption that oil or grease was absolutely necessary to reduce frictional resistance to movement between the surfaces in contact in a triple valve. He also pointed out that the quantity of oil being used in triple valves was gradually decreasing and as the practice is unnecessary it would be reasonable to assume that it would eventually be discontinued.

At the close of this discussion a paper on the subject of "Proper Piping of Locomotives and Cars; Specifications and Requirements for Pipe in Air Brake Work" was read by Mr. Fred Von Bergen, and discussed by the members. The object of the paper was to show the necessity for a correct length and installation of main reservoir piping on locomotives with a view of preventing the accumulation of water in the brake pipes

and in distributing valves on locomotives.

This was followed by the reading of a paper on the subject of "Excess Pressure," by Mr. M. S. Belk.

The use of 30 lbs. excess pressure in the main reservoir with the brake valve in running position was advocated instead of the usual 20 employed by some railroads.

We might add that this is already employed by a number of railroads, but other matters contributing to brakes striking, such as insufficient air pump and main reservoir capacity, inaccurate air gages, defective feed valves and brake pipe leakage were also mentioned.

A paper on "Adequate Hand Brakes on Heavy Passenger Equipment Cars" was read by Mr. F. J. Barry, after which a paper on the subject of "Need of Efficient Cleaning of Freight Car Brakes" was read by Mr. M. Purcell.

This paper and the discussion which followed emphasized the need of more efficient cleaning and repairing of freight car brakes, so that the interstate laws would be complied with, both in the spirit and the letter of the law.

Methods of systematic repair work whereby the brake cylinder leakage could be reduced to a point within the required limits were outlined and car brake work in general was touched upon.

The Air Brake Association's recommended practice was then accorded its annual revision. This is done without any confusion or lengthy discussion by the reading of only such paragraphs in which any changes or additions are to be made; such suggestions must be made by the members to the chairman by letter during the year and when read they are either approved and changed or rejected by vote. At this time the recommended practice was revised to agree with the requirements of the Federal law governing inspection and maintenance of locomotive and car brakes. But a very few changes in wording were necessary, as the recommended practice was given very careful attention by the members of the Interstate Commerce Commission before their laws were drafted.

A paper on the subject of "Elimination of Moisture in Yard Testing Plants," by Mr. M. Purcell, was also read. This was continued for the past two years in order that all of the information necessary to devise means for collecting moisture could be obtained and by adhering to piping arrangements suggested water can be prevented from entering the brake pipes on cars from the yard plants.

Very interesting and instructive entertainment was provided for the members during the intervals between regular sessions. During the afternoon of the first day the various supply men who had exhibits of their wares were given an opportunity to address the members who assembled in the hall, and they were very

cordially received and the exhibits much appreciated.

On the afternoon of the second day a moving picture exhibition showed the manner in which pipe was manufactured, from the time of the melting of the metal to the finished product. It showed the manner in which the butt-weld pipe was made and contrasted with the manner in which the lap weld was made. Altogether it was an instructive entertainment provided by the A. M. Beyers Company.

On the afternoon of Thursday, May 4, Mr. W. V. Turner, assistant manager of the Westinghouse Air Brake Company, delivered his annual lecture before the association. This consisted of fewer words than he generally uses in a lecture, as it was illustrated with a moving picture machine, it being the first time that a moving picture machine has been used for air brake instruction purposes, and judging from the manner in which it was given and received, the end of the present air brake instruction car and instruction room equipment in the way of apparatus, charts and sectional views, is in sight.

The *air brake problem* was depicted as a heavy Pennsylvania Railroad passenger train descending the two per cent grade on the Horse Shoe Curve, near Altoona, Pa. The train was photographed through the entire distance around the curve without a break in the film, and the solution of the problem was shown in a diagram of the general arrangement of the electro-pneumatic brake for steam road service.

The operation of the universal valve was then illustrated on the screen from a large diagrammatic view, and the compressed air was shown entering the valve from the brake pipe and charging all of the chambers and reservoirs. On a continuous film the effect of a service rate of brake pipe reduction was shown, the reduction starting and the equalizing piston and slide valve, the release piston structure and the emergency piston and slide valves moving to their application positions with the compressed air flowing through the various parts and passages necessary to produce the movements until the brake cylinder pressure was developed when the equalizing and emergency pistons returned to lap position the flow of air ceasing.

Pneumatic release, electric release and graduated release movements were shown, the exhausts of compressed air to the atmosphere appearing similar to puffs of smoke from a locomotive smoke stack.

The valve was then shown moving into quick action or emergency position, and the writer is unable to say whether the movements of all parts was technically correct as entirely too much transpired all at the same time, however after the shifting of air pressure and the various movements ceased, the parts were in the positions shown in the Standard dia-

grams of emergency position of this equipment the brake pipe pressure gradually disappearing, the quick action valve returning to its seat and the emergency switch piston to its original position after about the actual 10 seconds time had expired.

This exhibition was followed by an illustration in pictures of a variety of freak inventions for which patents had been granted which was exceedingly humorous, taking the crowd by storm.

At the close of this entertainment Mr. Turner received the greatest ovation that was probably ever accorded any air brake man.

The cost of producing this film was over 5,000 dollars and it was shown for the first time in public.

Judging from what has already been accomplished in the way of air brake instruction by moving pictures, that is, the ability to see the flow of compressed air and the actual movements of the various parts of a piece of apparatus so complicated as a universal valve, indicates that the same thing can be done with any other parts of a brake system and it would be a comparatively simple proposition with such parts as air compressors, brake valves, etc.

This feature of the Air Brake Convention was in itself well worth the time consumed in traveling to and from the meeting place.

Addresses were also made by Messrs. Cullenane and Hobson, representing the Interstate Commerce Commission which were of more than passing interest, as these gentlemen mentioned some instances of careless air brake inspection and entire neglect of inspection that came under their personal observation and which must be corrected if the laws are to be complied with.

A committee was appointed to prepare a paper on methods of brake inspection that will meet with the spirit and requirements of the law, the same to be read and discussed at the 1917 convention.

There was unexpectedly large attendance at the twenty-third annual convention and while we are concerned only with the mechanical part of it, it is only fair to acknowledge that the air brake men in attendance have never received more courteous consideration or kind treatment from any city in which a convention was ever held. Apparently everyone in the city of Atlanta knew the object of the meeting and were willing at any time to go out of their way to accommodate a member.

The officers elected for the ensuing year are Mr. T. W. Dow, president, Erie R. R.; Mr. C. H. Weaver, first vice-president, L. S. & M. S. R. R.; Mr. C. W. Martin, second vice-president, Pennsylvania R. R.; Mr. F. J. Barry, second vice-president, N. Y., O. & W. R. R. Mr.

F. M. Nellis, secretary, 165 Broadway, N. Y., Mr. Otto Best, treasurer.

#### W. V. Turner Lectures Before the Franklin Institute.

Mr. Walter V. Turner, speaking at the monthly meeting of the Franklin Institute of the State of Pennsylvania, at No. 15 South Seventh street, Philadelphia, Pa., on the subject "The Vital Relation of Train Control to the Value of Steam and Electric Railway Properties."

This lecture with illustrations demonstrated that train control is as an important a factor in the producing value of a railroad as is the locomotive. The fundamental purpose of a railroad is to save time, states Mr. Turner, and to avoid duplicating properties, capacity is essential and this involves high speeds and great frequency of trains. Increased capacity by such means is practicable only to the degree that train control is adequate. Safety is as essential to integrity of traffic and successful operation as earning power, consequently the relative value of railway properties is entirely dependent upon the ability to keep trains in motion, as close together as the state of the art for controlling trains will permit. Railroad capacity in cities is becoming an exceedingly important consideration, since the transient population of the day, or during the day, because of the "skyscrapers," is very great as compared with that of a few years ago.

Mr. Turner was in his usual form, delivering a lecture that was bristling with technicalities, touching more upon the engineering problem and summing up of requirements and factors than the actual development of the brake, which is by the way an improved electro-pneumatic type. The intent of the brake is to use the full potential of the rail, that is, to use every ounce of retarding force between the brake shoe and the wheel that the adhesion of the wheel to the rail will permit. This has been accomplished largely through the design of a weighing machine, through which the weighing of passengers getting on and off the cars automatically regulates the braking force delivered to the brake shoes, the weighing machine being connected between the car body and the truck. The machine is prevented from changing the braking force, due to the influence of curves and depressions in the track, by being cut out while the car is in motion, the cutting out and cutting in being done by the opening and closing of the car doors. It will be understood that the Interborough's Subway cars run with doors closed and are opened only at stations.

This brake system will be described in the Air Brake Department as soon as practicable, and the information given in the lecture will be printed either in this department, or from time to time in the pages reserved for Mr. Turner.



**Men Who Built Pittsburgh.**

The second lecture on "The Romance of Business" being given in the series of talks on "Pittsburgh, the City of Opportunity," was delivered last month before the Y. M. C. A. by W. C. Lyne, manager of the Union Central Life Insurance Company, his subject being "Pittsburgh and the Men Who Made It."

The lecturer traced the personal traits back of the achievements of such men as O'Hara, Westinghouse, Turner, B. F. Jones, Calvin Wells, William Thaw, Charles Lockhart, Vandergrift, Hussey, Henry Oliver, Carnegie and others figuring in Pittsburgh's natural development, and among other things said:

"There is a man in this city—the wizard of railroading—the man whom the most learned societies of America and Europe have honored with the most coveted medals of distinction for his contribution to humanity and science, who had been chosen as an honorary member with two or three other Americans by the Royal Society of Arts of England; this Pittsburgher, one of the 20 European and American scientists awarded the Elliot-Cresson medal, and who is recognized by the most learned societies of America as probably the foremost mechanical engineer living and the one who, with Westinghouse, saved more lives by his inventions than had ever been lost in any war before the beginning of the present European conflict, might walk into this room and be introduced, and the chances are not three persons present would know anything of this builder of Pittsburgh's industrial supremacy and contributor to humanity.

"I refer to Walter V. Turner, that modest and great Pittsburgh engineer whose inventions are used not only on every passenger and freight car, but of every traction car running over the streets of Greater Pittsburgh, and of whom it has been said that if his inventions were removed from the traction system of New York City there would be a daily congestion of travel, keeping 2,000,000 people from their business."

**Wasteful Heat Appliances.**

The steam engine has for years been held up as an awful example of waste of energy, utilizing as it does only about 1/10 of the heat of the fuel consumed in generating the steam used. Loss of energy is by no means confined to the steam engine. In a paper read before the Academy of Science of Washington by Professor Langley he demonstrated that in the argand burner only 24 parts of energy out of every 1,000 are utilized as light—a loss about four times greater than the steam engine.

**Goff's Electro-Pneumatic Brake System**

**Maximum Pressure at all Times Maintained**

Some months ago we printed a description of the Goff system of electro-pneumatic brakes for steam road service that was particularly adaptable to freight cars and at the present time we have a cut showing a brake system for street cars, that may also be used in steam railroad

reservoirs at all times, regardless of repeated applications of the brakes, which insures efficiency and safety, particularly on mountain grades or in congested traffic centers. Full combined capacity of the car reservoir, brake pipe and air compressor may be delivered to the brake cyl-

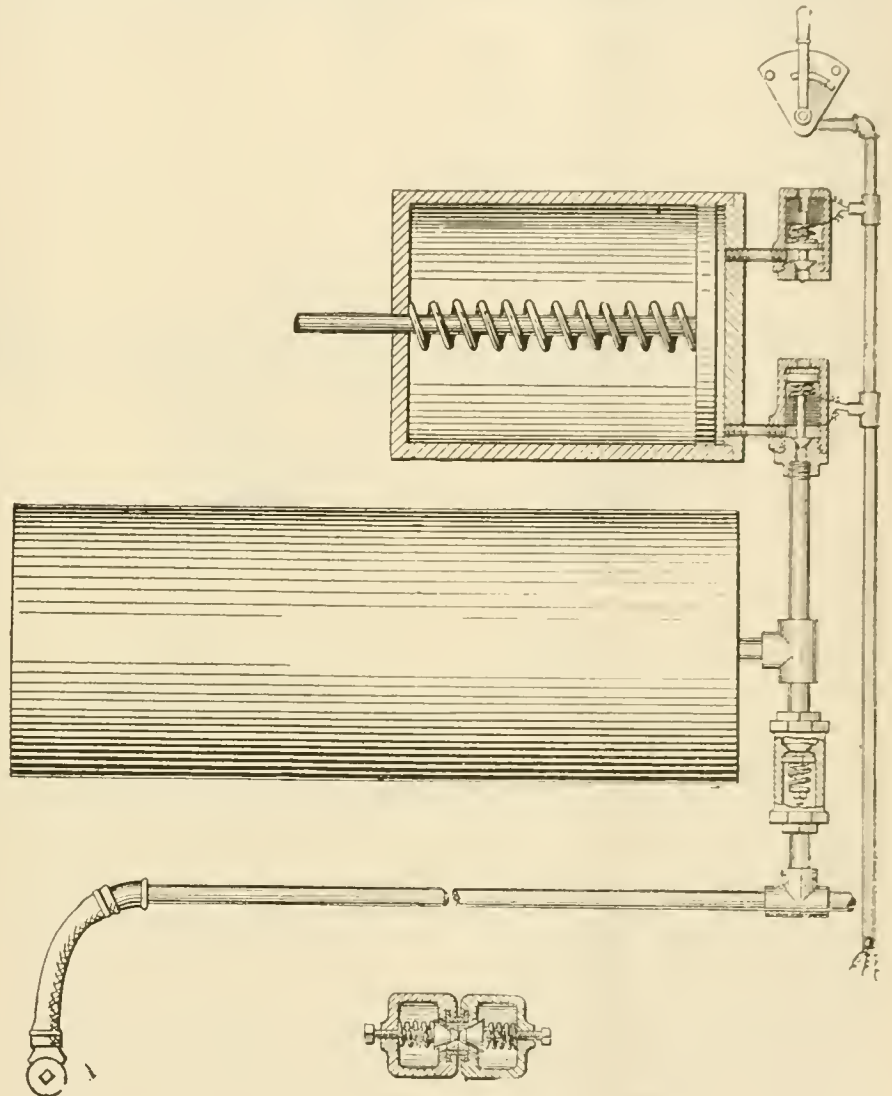

RESERVOIR AND BRAKE CYLINDER GOFF ELECTRO-PNEUMATIC BRAKE.

service. The illustration shows the complete system for a car, and it will be observed that no triple valves are required, the brake however being automatic. The inventor claims, and a study of the description will show, that the brakes will positively apply whenever the motorman so desires, or in all cases of accident or failure, such as broken wires, failure of current, battery or generator from any cause. The brake may be applied or released in full, or graduated on or off with any desired pressure. Accidental bursting of the air hose or brake pipe does not interfere with the application or the release of brakes. The maximum air pressure is maintained in the

inder, guaranteeing a high pressure emergency brake.

A glance at the cut will show that this device is so simple as to require no lengthy description, an ordinary electro-magnet being used to control the flow of compressed air from the auxiliary reservoir to the brake cylinder and another to control the flow from the brake cylinder to the atmosphere when a release is desired. The system differs from the usual electrically controlled brake in that the application magnets are energized when the brake is applied and when these magnets are de-energized by a movement of the brake valve on the locomotive or by a rupture in the brake pipe, the magnet

valves will admit compressed air to the brake cylinder applying the brake. The magnet valve controlling the flow of air from the brake cylinder is normally closed with the magnet de-energized and when a release of brakes is desired, the release circuit is closed at the control switch energizing the release magnet, drawing the exhaust valve away from its seat opening the brake cylinder to the atmosphere. This may be repeated as often as desired, graduating the pressure out of the brake cylinders.

We are not at this time in a position

48 State Commissions, and he also urged that the public be given a voice in deciding the controversy between the organized employes in train service who are seeking an advance in wages through the movement for an 8-hour basic day, with time and half-time for overtime.

"The defect," Mr. Willard said, "of the present system are becoming better understood. No one would contend or expect that 48 different regulating bodies, with interests sometimes at variance, could satisfactorily and efficiently supervise and regulate the same subject at the same

detail than of principle. I think a careful survey of the matter will develop that we have already gone a long way toward Federal regulation of railroads—much further, in fact, than is generally supposed, without being fully aware of the change, and it now requires little more than that the actual status should be fixed by Congress.

"Certainly the men who operate the trains and engines should be a selected class, and they should be well paid and given good and suitable working conditions, and if the carriers are not already

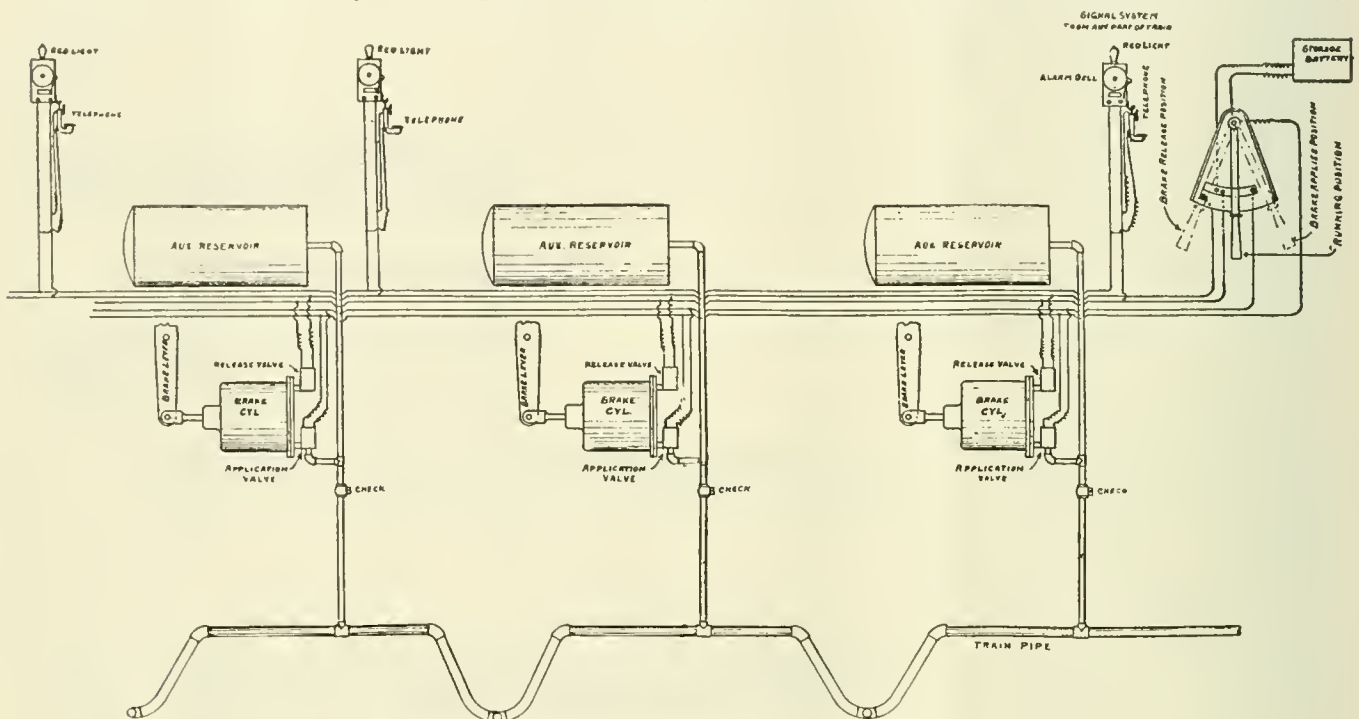

GOFF ELECTRO-PNEUMATIC BRAKE AND SIGNAL SYSTEM.

to comment on the merits of this brake system or on any other until such time as it has told its own story in actual service under modern operating conditions, but the brake system will be set up and be in operation at the Master Mechanics' Convention at Atlantic City this year, and practical demonstrations of the operation of the brake may be witnessed at any time at 523 Haddon avenue, Camden, N. J. The brake was invented by Mr. Frank Goff, a locomotive engineer on the Pennsylvania Railroad.

#### President Willard of the Baltimore & Ohio on the Railroad Question.

Mr. Daniel Willard, president of the Baltimore & Ohio Railroad System, in an address delivered last month to the members and guests of the American Newspaper Publishers' Association on certain national phases of the railroad question, advocated that railway control be centralized in the Federal Government rather than the present dual system vested in the Interstate Commerce Commission and

time, although that is exactly what we are trying to do under our dual system of Federal and State regulation of railroads. It no doubt seemed necessary in the past for the individual States, or some of them to act in fields where the Federal Government should have acted, but had neglected to do so, but as we have gradually grown and become transformed from a loose confederacy of States into one great nation, the necessity for Federal, instead of State control, has become more and more apparent concerning many matters of nation-wide importance—such necessity has been reflected in a Federal Postal System, the National Bank Act, National Bankruptcy Act, and more recently, the Federal Reserve Act, Federal Trade Commission, etc. Gradually, consistently and naturally, as I view it, the change in railroad regulation from State to Federal is also taking place, and the thing most desired is that the complete change shall be accomplished in as brief a time as practicable, consistent with orderly transition. I believe few, if any radical changes in the laws, will be necessary and such changes as may be made will be rather changes of

paying such wages and providing such conditions, they should be required in the public interest to do so, and if it should then appear that upon the existing basis of rates and fares the revenues of the carriers were not sufficient to yield a fair return upon the value of the properties devoted to the public use, after paying the increased wages, then such increase of rates should be permitted as would fairly meet the situation. On the other hand, I can think of no sound nor sufficient reason for imposing an additional burden upon the public in the way of increased rates if, after a full and careful inquiry into the whole matter by a competent body selected for that purpose, it should be found that the wages and working conditions of the particular men involved in this question are now on a proper and equitable and even liberal basis. There should be the fullest possible publicity concerning the whole matter as a basis for correct public opinion. It has been well said that, 'Public opinion and patience are the best possible agents for successfully solving industrial, social and economic problems.'

# Electrical Department

## Introductory and Catechism of the Electric Locomotive, Etc.

### Introductory.

We are now living in the age of electricity; we have the telephone, electric light and electric motors. It is a curious fact that the steam railroad which has made such rapid progress and has done the most to advance civilization has thus far benefited least by the development of electricity; but it is certain that before many years it will, as a whole, be a greater user of electricity than any other industrial class.

The electric locomotive is no longer an unknown quantity. It is today performing in all kinds of service; it is operating in tunnels, through rivers, in slow speed and high speed freight service, in switching and in fact, in all kinds of service, and is performing this service at an expense which is lower than if performed by the steam locomotive. Electric locomotives were first used in terminal work because of the nuisance and discomfort to passengers and others of steam power. Many benefits which were not at first apparent, have developed and these advantages are so great that in the future, only electricity will be considered for a large terminal in a large centre. By the use of electricity, it is possible to establish a great railway terminal without annoyance or discomfort to the people and without loss of the valuable land for building purposes. The electric locomotive, moreover, increases the capacity of the terminal owing to the greater rapidity of its movement and to the fact that it does not have to be turned, coaled, watered, fires cleaned nor its boiler washed.

A few of the most important electrifications are:

#### THE TERMINAL OF THE NEW YORK CENTRAL RAILROAD, NEW YORK CITY—

which was electrified to eliminate the danger due to smoke in the Park Avenue Tunnel, which electrification has been extended so as to get the benefit of the suburban traffic, which is so satisfactorily and economically handled by multiple unit trains.

#### THE PENNSYLVANIA RAILROAD TERMINAL, NEW YORK CITY—

It was due to electricity that this feat was possible, as in no other way could the passenger trains be hauled under the rivers on either side of Manhattan.

Operating conditions in these tunnels are such, due to grades, heavy trains and high speeds, that it would be almost impossible to handle the service by steam even if it were possible to eliminate the smoke.

The electric locomotives in operation on the Pennsylvania Railroad are extremely powerful and not only operate at high speed, but have sufficient capacity for hauling heavy loads.

#### THE DETROIT RIVER TUNNEL ELECTRIFICATION—

is another example of the advantages to be derived from electric operation. For several years, the Michigan Central Railroad was obliged to transfer its trains across the congested Detroit River on ferryboats, but due to the success of electric traction, the building of a tunnel under the river was justified and trains are now handled by electric locomotives without the delay previously experienced.

#### THE NEW YORK, NEW HAVEN & HARTFORD RAILROAD ELECTRIFICATION—

comprises approximately 550 miles of electrified track with an equipment consisting of passenger, freight and switching locomotives, together with multiple unit cars.

#### LONG ISLAND RAILROAD.

The electrification of this road was done to better serve the suburbs of New York City and at certain seasons, to handle heavy excursion business to the seashores of Long Island. This electrification connects up with the Pennsylvania Railroad electrification, New York City, and frequent and quick service without transfer is available from the heart of Manhattan to within 25 miles of New York City, the electrification comprising something like 88 miles. The service is operated by multiple unit motor-car trains and 650-V. direct current is used as the source of power.

#### BUTTE, ANACONDA & PACIFIC RWY.

This road is principally a freight-handling road, hauling copper ore from mines in the vicinity of Butte, Montana, to the smelters near Anaconda. By means of this electrification, it has been possible to haul longer trains at higher speeds, which, together with the cheaper cost of power, operating savings can be effected. The electrification is a 2400-V. one and was the first example in this country of the use of 2400-V. direct current.

#### ERIE RAILROAD ELECTRIFICATION, ROCHESTER DIVISION.

This electrified section covering a distance of 34-root miles from Rochester to Avon, with a branch to Mt. Morris, was installed largely as an experiment to study the effect of electric traction on traffic and operating costs. The service which is confined to passenger traffic and handled

by multiple unit motor cars, has been very successful and a very nice local and interurban business has been built up.

#### BALTIMORE & OHIO RAILROAD.

This railroad was the first road in America to employ electric power for hauling heavy passenger and freight trains. At the time electricity was installed on this road, only very small electric motors had been built and heavy electric currents had not been collected from third rails. This electrified section of only 3.7 miles was installed to eliminate the objection of steam operation in a tunnel 1½ miles in length.

#### GRAND TRUNK RAILWAY.

This electrification was decided upon as a means of eliminating the dangerous atmospheric conditions in the tunnel under the St. Clair River from Sarnia, Ontario, to Port Huron, Michigan. Originally, trains were handled through this tunnel by steam locomotives which were limited to a maximum weight of train. Increase in traffic necessitated an increase in the capacity of the tunnel and due to dangerous gases, it was practically impossible to increase the steam locomotive power. The single-phase alternating current system with overhead trolley is employed with a voltage of 3300-V.

#### GREAT NORTHERN RAILROAD.

This railroad passes through the Cascade Mountains in the state of Washington, through a tunnel 2½ miles long, the capacity of this tunnel being the limiting factor in the capacity of the line for hauling freight across the mountains.

The main object of this electrification was to eliminate the smoke and gases emitted in the tunnel by the steam locomotives and to increase the capacity of the line. The three-phase system of electrification was used, this being the first and only electrification of this type in this country.

#### CHICAGO, MILWAUKEE & ST. PAUL RWY.

This electrification is one of the most recent and is using the highest direct current voltage ever installed in steam operation in this country, namely 3000-V. Ultimately, the electrification will be approximately 400 miles long and will carry the trains over three mountain ranges.

#### NORFOLK & WESTERN RWY.

This is the most important electrification to date and the most interesting. The locomotives weigh 270 tons and have a maximum tractive effort of 170,000 lbs. It was particularly fortunate that this economical method of operation was installed in time to handle the unusual move-

ment of coal, which has been a feature of the current year. Twelve electric locomotives have replaced thirty-four Mallet steam locomotives. A very interesting feature on these locomotives is that of regeneration, which makes it possible for a train to descend the Elkhorn Grade without brakes applied to the wheels.

From the above mentioned electrifications, it is clearly seen that electric operation has to meet a wide variation of service conditions and this has brought out electrical systems. We have for instance, the 600-volt system, the high voltage direct current system, the single-phase system, the three-phase system and the split phase system, each of which has its characteristics which make it perhaps better suitable for a certain type of service than either of the other systems.

Electrifications and the electric locomotives have come to stay and will increase rapidly. Every employee whose duties are in anyway connected with the operation or maintenance of electric locomotives should have a knowledge of the electrical apparatus. Engineers should familiarize themselves with the name, location and purpose of all of the pieces of apparatus which go to make up the locomotive, and should know the general principles upon which operation of the various pieces of apparatus depends, the manner in which it should be operated and the procedure to follow in case of failure on the road. Firemen having no specific duties to perform while on the electric locomotive, except that of helper, should for their own benefit, familiarize themselves with the electric apparatus and should consider the following catechism as essential as does the engineer.

#### Catechism of the Electric Locomotive.

Q.—What is an electric locomotive?

A.—An electric locomotive is a machine which takes electric power and delivers it to electric motors which are connected mechanically with its driving axle, thereby developing tractive effort for the hauling of a trailing load.

Q.—Wherein is the electric locomotive fundamentally different from the steam locomotive?

A.—It is not a self-contained power unit, but receives its power from the central power source, transmitted to it through overhead conductors or a third rail, the latter located adjacent to the running rail. Although there are in reality, two distinct types of electric locomotives,—the alternating current and the direct current—they are, with the exception of minor details, similar. The boiler, the air pump, the throttle and the cylinder of the steam engine are represented in the electric locomotive by the electrically-driven air-compressor, the master controller and by the motors respectively.

Q.—How often must electric locomo-

tives be taken to the round-house for inspection?

A.—Since the fire-box, front end, etc., are eliminated in the electric locomotive, it possesses a great advantage in that it can be run for twenty-four hours a day and day after day with only a lay-up of from two to three hours after every 1500 to 2000 miles, for shop inspection. The electrical apparatus is so designed that it can be inspected on a mileage basis.

Q.—In the case of the steam locomotive, the maximum drawbar pull depends

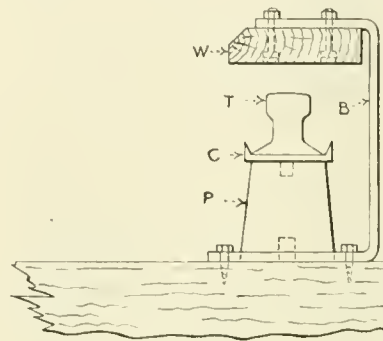

FIG. 1. THIRD RAIL CONSTRUCTION ON TOP CONTACT.

upon the diameter of the cylinders and the boiler pressure, both fixed quantities, and it is impossible to overload the engine; is this true of the electric locomotive?

A.—No,—as in the case of the electric locomotive, the work done depends upon the amount of power delivered to the motors, and as this power is practically unlimited due to the fact that it is sup-

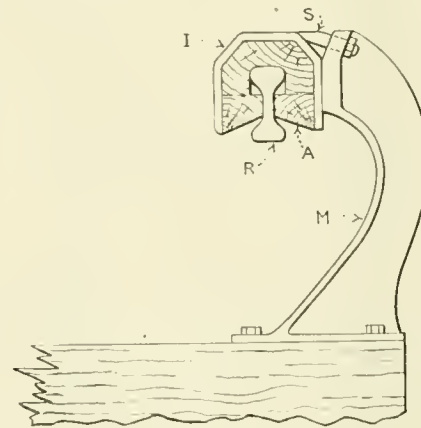

FIG. 2. THIRD RAIL CONSTRUCTION IN UNDER RUNNING.

plied from an external source of large capacity compared with that of the locomotive, the electric locomotive can be overworked, resulting in burned-up motors and damaged electrical apparatus. The electric locomotive will not stall, but will continue to work until damaged. It is therefore very important with electric operation to have the locomotive haul the load designed for, and not the load it is capable of handling momentarily or for short periods of time.

Q.—From where does the electric locomotive receive its power?

A.—From overhead wire or wires, or from a third rail located adjacent to the running rails.

Q.—How is this power collected?

A.—In the case of third rail operation, by means of third rail shoes carried on the trucks of the locomotive, this shoe being held by spring pressure against the third rail.

In the case of the overhead wires, it is collected by means of a sliding shoe or in cases of slow speed locomotive, by a roller, this shoe or roller carried on a collapsible frame, called a "pantograph."

Q.—What is your understanding of electric power or electricity?

A.—Electricity flowing in a wire is analogous to water flowing through a pipe. In the pipe are a certain number of units, say, cubic inches per minute of water flowing and at a certain pressure in pounds per square inch. So in the wire or third rail carrying electricity, there is the volume in terms of the electrical unit, known as the "ampere" and there is a pressure in terms of a unit, called the "volt." Increasing the pressure in the pipe, increases the flow of water, the outlet remaining the same. This is true with electricity; increasing the volts, increases the current flowing provided the resistance (or opening as it is in the case of water) remains the same. Also if the opening in the pipe is closed, there will be no flow of water, but the water will still be at a pressure. Same is true with electricity, in that a conductor, such as the wire or third rail, will be under an electrical pressure or in electrical terms, will be at a certain voltage, although no current or amperes are flowing. Bear in mind that in the case of water, we are dealing with a concrete claim, while electricity is only known through what it is capable of doing. We do not know what electricity is, we only know many of the things it does. As the power obtained from the water in the pipe is equal to the product of the amount flowing by the pressure, so with electricity, the power is equal to the product of amperes by volts and this product we call "watts."

As it is necessary to use thicker and better pipe as the pressure increases, so it is necessary to use higher and better insulation as the voltage increases, so as to prevent this voltage from breaking down and short-circuiting the line which is analogous to the bursting of the water pipe. As it is necessary to use larger pipe to carry more water a given distance or the same amount of water a longer distance with the same drop in head to the pipe, so it is necessary with electricity to use larger wires or conductors to carry more amperes or to carry the same amperes a greater distance with the same loss in pressure or voltage.

Q.—What are the two distinct types of electric locomotives?

A.—The direct current locomotives and the alternating current locomotives.

Q.—What do the letters "D. C." stand for?

A.—Direct current.

Q.—What do the letters "A. C." stand for?

A.—Alternating current.

Q.—What voltages are used with D. C. locomotives?

A.—Until the past few years, 600 to 700-V. was the prevailing voltage and was considered a maximum. Now there are D. C. locomotives operating on 1200-V., 1500-V., 2400-V. and 3000-V.

Q.—What voltages are used with A. C. locomotives?

A.—Generally, 11000-V.

Q.—Power for the locomotive is collected from either an overhead wire or a third rail. Under what conditions are each used?

A.—On D. C. electrifications of 600 to 700-V., a third rail is used. In dry climates with sandy soil, it is possible to use 1200-V. D. C. voltages of 2400 and 3000-V. are used with overhead wires. A. C. electrifications all use overhead wires since they are generally of high voltage insulation.

Q.—What are the objections to using 2400-V. D. C. or 3000-V. D. C. on third rail conductors?

A.—It is purely a question of insulation. We have seen from the above that voltage is pressure and that the higher the voltage, the greater must be the insulation strength. With the third rail near the ground and more or less limited in space, the insulation which would be required to insulate the 2400-V. would be a handicap and moreover, quite expensive. With the wire overhead, it is possible to insulate for very high voltages.

Q.—What advantage is gained in going to high voltage?

A.—The power required by the locomotive can be transmitted from the powerhouse with less loss and better voltage is obtained.

Q.—How is this possible?

A.—The power as we have seen is represented by watts which is the product of volts times amperes. A locomotive running under certain conditions requiring a certain amount of tractive effort, will require a certain amount of power to be taken from the electrical conductor, so that with different voltages applied to the locomotive, the product of volts times amperes will be the same. It is readily seen that raising the voltage therefore decreases the current, and with the decrease of current, there can be a corresponding decrease in the size of the conductor, or with the same conductor, the lower current value gives less loss and, in turn, better voltage at the locomotive and better operating conditions.

Q.—What are the two types of third rail construction?

A.—The under-running third rail and the top contact third rail.

Q.—What is the construction of the top contact third rail?

A.—This construction is shown by Fig. 1. On every six to eight ties—which is longer than the regular tie and extending to the right, is bolted the bracket B. This bracket is bolted near one edge so as to give sufficient room for the porcelain insulator P, this insulator being mounted on a pin to hold it in position. On top of the insulator is placed a cap C to form a rest for the third rail T. The bracket B is used to carry the protection board W. The third rail shoe on the locomotive runs along on the top of the third rail and underneath the protection board.

Q.—What is the construction of the under-running third rail?

A.—On the long ties are bolted the malleable iron brackets M, Fig. 2. Each of these brackets is provided with a clamping strap S, which clamps a split insulator I around the third rail R, and holds this rail securely and at the proper height above the tie. Between each of the insulators is usually placed strips of wood, shown in sectional pieces A, these pieces of wood serving protection from contact with the rail. The top of the third rail shoe bears against the underside of the third rail R.

#### Type CI Slip Ring Induction Motor.

A new line of slip ring induction motors (type CI) for severe, intermittent, varying speed service has just been developed by the Westinghouse Electric & Mfg. Co., of East Pittsburgh, Pa. These motors are especially designed for heavy duty on cranes, hoists, drawbridges roller lift bridges, railway turntables, transfer tables and similar applications. They can be furnished in sizes from 1½ to 200 horsepower for operation on two or three-phase, 220 or 440-volt, 25 and 60-cycle circuits.

The frames of the smaller sizes are made up of steel laminations riveted between forged steel and shields; in the larger sizes the frames are made of rolled open-hearth steel. The brackets are of cast iron with reinforcing ribs to assure rigidity and perfect alignment of the bearings at all times. The bearings are self-oiling of the oil-ring type, and are large in size. The steel brush holders are supported by and insulated from the bracket, which is open to permit easy inspection and renewal of the brushes.

The rotor is small in diameter, thus reducing the fly-wheel effect. This feature, together with perfect balance and secure attachment of the windings, makes these motors especially adapted for frequent starting, stopping and reversing. The

shaft is of axle steel and can be removed from the rotor without disturbing the windings.

The running torque of these motors is the maximum obtainable and the starting and pull-out torques in all motors exceed twice full-load torque. They are so constructed that, in case of accident, repairs

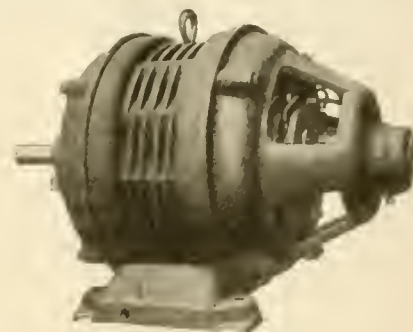

TYPE CI SLIP RING INDUCTION MOTOR.

can be quickly made, and maximum strength is obtained while weight and overall dimensions have been reduced to a minimum.

#### Profiting by Mistakes.

There are some kinds of mistakes that human nature insists on making in each individual case, and no amount of experience gone through by others will prevent constant repetitions. It is useless for a father to tell his sons, that he has been all through the list of indulgences in the shape of dances, horse racing and the circus and seen the folly of them. The boys want to see the folly of them for themselves. No mother ever persuaded her daughter against marrying, by pointing out her own cares and responsibilities.

But it seems that railway men ought to be willing to show up some of their mistakes, just to keep others from falling into the pit that brought them to grief, and for the general information of the craft. We recently visited a shop in company of a man who had gone through the experience of shop foreman, general foreman and master mechanic and is reputed to have been an excellent mechanical engineer. The general foreman of one shop showed us a device he had just completed for turning up crank pins. When we left the place my companion said: "That crank pin turning device won't work. I was all through that ten years ago." Then he gave a very good reason why it failed, and showed where the design was at fault.

When asked why he did not inform the foreman of his former experience with the invention, he answered that he had learned by experience and that the foreman might do the same. This seemed to me to be a very narrow view to take of a neighbor's difficulty, but it represents a common case. There is an old anecdote about a dog in a manger, whose application is not confined to dogs.

# Items of Personal Interest

Mr. C. D. Potter has been appointed master mechanic of the Pennsylvania, with office at Pittsburgh, Pa.

Mr. W. H. Wortman has been appointed locomotive foreman of the Canadian Pacific, with office at Calgary, Alta.

Mr. G. Twist has been appointed locomotive foreman of the Canadian Pacific, with office at Ft. William, Ont.

Mr. P. S. Beatt has been appointed locomotive foreman of the Canadian Pacific, with office at Ogden, Alta.

Mr. E. R. Mills has been appointed locomotive foreman of the Canadian Northern, with office at Dauphin, Man.

Mr. A. W. Clark has been appointed locomotive foreman of the Canadian Pacific, with office at Brandon, Man.

Mr. W. Mills has been appointed car foreman of the National Transcontinental, with office at Transcona, Man.

Mr. B. T. Patterson has been appointed night locomotive foreman of the Canadian Northern, with office at Rainy River, Ont.

Mr. C. D. Barrett has been appointed assistant engineer of motive power of the Pennsylvania, with office at Altoona, Pa.

Mr. L. L. Hoffman has been appointed roundhouse foreman on the Chicago, Rock Island & Pacific, with office at Liberal, Kan.

Mr. W. Shephard has been appointed locomotive foreman of the Canadian Northern, with office at Portage La Prairie, Man.

Mr. H. E. Pierce has been appointed general car foreman of the Illinois Central, with office at Weldon passenger yard, Chicago.

Mr. Joseph E. Brown has been appointed eastern sales manager of the O'Malley-Bear Valve Company, with offices in New York.

Mr. T. F. Phelan has been appointed road foreman of equipment of the Chicago, Rock Island & Pacific, with office at Haileyville, Okla.

Mr. C. J. Wymer, formerly general car foreman of the Belt railway of Chicago, has been appointed general sales agent, Grip Nut Company.

Mr. R. A. Huey has been appointed general locomotive foreman of the Chicago, Rock Island & Pacific, with office at Armourdale, Kan.

Mr. A. W. Martin has been appointed superintendent of shops of the Cleveland, Cincinnati, Chicago & St. Louis, with office at Beech Grove, Ind.

Mr. J. M. Kerwin has been appointed master mechanic of the Dakota division of the Chicago, Rock Island & Pacific, with office at Estherville, Iowa.

Mr. S. E. Mueller has been appointed general foreman of the locomotive department of the Chicago, Rock Island & Pacific,

with office at Cedar Rapids, Iowa.

Mr. George Webber, formerly traveling engineer of the Spokane division of the Great Northern, has been appointed master mechanic, with office at Minot, N. D.

Mr. Henry C. Hammack, formerly assistant secretary of the Lima Locomotive Corporation, Lima, Ohio, has been elected secretary, succeeding Mr. John H. Guess, resigned.

Mr. L. J. Drake, formerly resident manager of the Galena Oil Company, at Indianapolis, Ind., has been elected vice-president of the company, with offices at New York.

Mr. L. H. Cota has been appointed bonus supervisor of the eastern lines of the Santa Fe, with office at Topeka, Kan., succeeding Mr. D. E. Barton, assigned to other duties.

Mr. Earl E. Shock has been appointed car foreman of the Chicago, Milwaukee & St. Paul, with office at Marmarth, N. D., succeeding Mr. T. J. Scanlon, transferred to Mobridge, S. O.

Mr. A. Brown, formerly district master mechanic of the Canadian Pacific at Winnipeg, Man., has been appointed master mechanic on the same road, with office at Revelstoke, B. C.

Mr. N. J. Renix, formerly district master mechanic of the Canadian Pacific at Revelstoke, B. C., has been appointed master mechanic of the Saskatchewan division, with office at Moose Jaw, Sask.

Mr. D. M. Crossman has been appointed advertising manager of the Niles-Bement-Pond Company, New York, succeeding Mr. Henry M. Cleaver, who is now at the company's works, Plainfield, N. J.

Mr. Samuel M. Vauclain, vice-president of the Baldwin Locomotive Works, has been elected a director of the Westinghouse Electric & Manufacturing Company, succeeding Mr. C. F. Brooker, resigned.

Mr. R. J. Williams, formerly superintendent of the Big Four shops at Beech Grove, has resigned to become assistant superintendent of motive power of the Missouri, Kansas & Texas, with office at Parsons, Kan.

Mr. Fred W. Hankins has been appointed master mechanic of the Cumberland Valley, with office at Chambersburg, Pa., and Mr. G. Bennett has been appointed assistant master mechanic, also at Chambersburg.

Mr. M. G. Charles, master mechanic of the Oregon Electric and United Railways of Portland, Ore., has had his jurisdiction extended over the Portland division of the Spokane, Portland & Seattle, with office at Portland.

Mr. C. D. Cronk, formerly assistant engineer, signal department of the New York Central Lines East, at Albany, N. Y., has been appointed signal engineer, New York Central Lines West, with office at Cleveland, Ohio.

Mr. Robert Schule has been appointed master mechanic of the Montana division of the Great Northern, with office at Havre, Mont., succeeding Mr. J. C. Benson, who has been transferred to a similar position in the Butte division of the same road.

Mr. F. H. Nicholson, formerly signal engineer of the New York, New Haven & Hartford, at New Haven, Conn., has been appointed assistant signal engineer, in charge of speed control and automatic stop investigations, with office at New Haven.

Mr. H. H. Maxfield has been appointed superintendent of motive power of the Western Pennsylvania division of the Pennsylvania, with office at Pittsburgh, Pa. Mr. Maxfield is a graduate of Stevens Institute, and has been in the employ of the Pennsylvania Company over 20 years.

Mr. W. O. Thompson, secretary of the Traveling Engineers' Association who has been for years district master car builder of the New York Central Lines, east of Buffalo, has been promoted to be superintendent of rolling stock of the lines west, with headquarters at Cleveland, O.

Mr. E. Hartenstein, formerly road foreman of engines on the Northern division of the Chicago & Alton, has been appointed superintendent of air brakes on the same road, with headquarters at Bloomington, Ill., and Mr. F. W. Geiler succeeds Mr. Hartenstein as road foreman of engines, also with office at Bloomington.

Mr. Alonzo G. Kinyon, superintendent of locomotive operation, on the Seaboard Air Line Railway for a number of years, has resigned this position to become chief consultant of the Board of Engineering Research Power Generation in Steam Locomotives, for the Powdered Coal Engineering & Equipment Company, Chicago. Mr. Kinyon's knowledge of matters cover a wide period of service. Starting on the Chicago, Milwaukee & St. Paul Ry. as a fireman 28 years ago to shovel coal into the locomotive firebox, it has been one of his ambitions in life to make for the railroad fireman a position of betterment. As a member of the executive committee of the International Railway Fuel Association and as vice-president of the Traveling Engineers Association, Mr. Kinyon has always advocated the use of modern labor-saving devices on railway equipment. In

his new position he will have full charge of all development work for locomotive operation.

Mr. T. W. Dow, General Air Inspector of the Erie, with office at Meadville, Pa., and who has been elected President of the American Air Brake Association, is



T. W. DOW.  
President American Air Brake Association.

a thorough expert in all matters pertaining to the air brake. He entered the employ of the Fitchburg railroad, now a part of the Boston and Maine system. In 1888 he was made Air Brake inspector, and in 1892 was promoted to Air Brake instructor, continuing in that capacity until appointed as General Air Brake Inspector on the Canadian Pacific, in 1901. In 1904 he was appointed General Air Brake Inspector on the Erie, and has remained with the Company ever since.

**OBITUARY.**

**James F. Walsh.**

The numerous friends of James F. Walsh, for ten years superintendent of



J. F. WALSH.

motive power of the Chesapeake & Ohio Railway, will regret to learn that he

died suddenly of apoplexy at Roanoke, Va., on April 13. Mr. Walsh was performing the active duties of consulting mechanical engineer when, without the least warning, he passed to his eternal rest.

James F. Walsh was born at Cleveland, O., in 1857, so he was 59 years old at the time of his death. He was educated in the public schools of Cleveland and entered railway service in 1871 as machinist apprentice in the repair shops of the Cleveland, Columbus, Cincinnati & Indianapolis Railway. His father, Thomas Walsh, was a locomotive engineer who rose to be engine dispatcher and was a celebrated man in his day, so it was natural for the son to follow in his father's footsteps.

From machinist apprentice James went firing and in due course became engineer, then roundhouse foreman. He left railway life for a time to become mechanical expert of the Galena Oil Company, but in 1902 returned to the Chesapeake & Ohio Railway as superintendent of motive power. That position he relinquished in 1912 and became mechanical engineer for the company, the position he filled at the time of his death.

Mr. Walsh is survived by his wife, one daughter and three sons.

**James J. Hill.**

James J. Hill, the greatest railroad builder the world has ever seen, has passed away as we go to press. He climbed from the bottom of the ladder and studied as he rose. He commanded peace armies with which he conquered the wilderness. He saw clearly and gave the people the benefit of his views. Mr. Hill's interviews became a feature of the newspapers and all that he said commanded attention. He was an optimist but he occasionally pricked bubbles and put his finger on weak spots, as when he said that the United States was not "suffering from the high cost of living but from the cost of high living."

Mr. Hill built up the territory through which the Great Northern Railroad runs by helping the farmers to select the right grain, live stock, and methods. When any industry needed help he held out his hand. He made special rates for timber in the Pacific Coast States to give it a market in the East and he put American manufacturers in touch with the Orient in the same way. From Buffalo to Hong Kong his steamers and railroads were among the chief stimulants to American progress. He was straightforward in word and deed and the public had faith in him. His last great task, the only one unfinished when his call came, was the succor of the people of Belgium, a noble effort with which to conclude a long and useful life.

**The Bruston Electric Lighting Company.**

The marked success of the portable electric lighting system established by the Bruston Electric Lighting Company has compelled the enterprising firm to move to more commodious quarters, and their growing host of patrons will now find the company located at the Architects' Building, 101 Park avenue, New York City.

**Goldschmidt Thermit Company.**

The Goldschmidt Thermit Company, formerly located at 90 West street, New York, has moved to more commodious quarters in the New Equitable building, No. 120 Broadway, New York.

**Pressed Steel Car Company.**

The Pressed Steel Car Company and Western Steel Car & Foundry Company announce the removal of their offices to suite 425, Peoples Gas Building, Chicago, Ill.

**The Hotel Pennsylvania.**

The Pennsylvania Terminal Real Estate Company announces that a hotel will be erected on Seventh avenue, between Thirty-second and Thirty-third streets, New York City, to be known as the Hotel Pennsylvania. It will be connected with the Pennsylvania station by an underground passageway. In 1917, when the hotel is opened, there will be direct passenger service between the station and New England, so that the patrons can travel in all directions without going from under shelter. The hotel will occupy 200 feet on Seventh avenue and 400 feet on Thirty-second and Thirty-third streets. When completed, with proposed additions, it will provide 2,200 rooms. Messrs. McKim, Mead & White, the architects who prepared the plans for the Pennsylvania station, are the architects, and it will be leased to Mr. F. J. Matchette, of Milwaukee, Wis., for a period of 21 years

**Work on the Quebec Bridge.**

Work is now progressing rapidly on the construction of the second Quebec bridge. On the north shore the entire cantilever arm has been completed, thus practically completing all the steel work on that side. On the south side the steel work has been completed up to and including the main post over the main pier. This year the south cantilever arm will be erected, and the work of erecting the suspended span will be commenced early in the spring at Sillery Cove and will be completed by the time the cantilever arm is ready to receive it. It will then be floated into place and suspended from the two ends of the cantilever arms.

## Eighth Annual Convention of the International Railway Fuel Association

The eighth annual convention of the above association was held at the Hotel Sherman, Chicago, Ill., May 15-18. Mr. D. C. Buell, presided, and in the course of an able opening address suggested a number of improvements in the use of locomotive fuel, and laid particular stress on the establishment of a school for firemen at some central point on each system. An interesting report was presented in regard to the recent revival of the use of powdered fuel in locomotives and an assurance expressed that fuel in a pulverized form for generating power, and heat and light on railways, will be quite marked from now on, and a saving of 15 per cent. had already been effected in some of the experiments, and larger results might confidently be anticipated. The drying and pulverizing of the fuel showed variations running from 29 cents to \$1 per ton, according to the varying capacity of the pulverizing mills.

In the discussion on the analysis of coal it was claimed that the moisture content of the coal, so frequently complained of, was objectionable only to the extent that it was being paid for as real coal. The functions of railroad fuel inspector were fully explained by Mr. E. McAuliffe. Briefly, his duties are to establish a proper standard of quality—to measure results quickly and accurately—to make the mine employees his willing helpers, and to establish and secure automatically a standard of efficiency.

Mr. I. M. Felton, president of the Great Western, made a very interesting address on the subject of fuel saving, and presented some remarkable data in regard to the amount of saving effected by improved appliances and thorough training. Mr. W. H. Averell, of the Baltimore & Ohio, followed on the relation that fuel economy had to the transportation department. He laid particular stress on the importance of the position of head of the fuel department. Mr. D. J. Feeney, of the Illinois Central, explained the methods in vogue on that road, and approved of meetings of divisional committees, the result being a decrease in 10 per cent. of fuel and an increase of 7 per cent. on tonnage. Mr. A. N. Willsie, of the Chicago, Burlington & Quincy, followed along similar lines, referring particularly to the care of locomotives, and called attention to the losses by air leakage, and also warmly recommended the use of pyrometers on Mallets.

Mr. J. G. Crawford, also of the Chicago, Burlington & Quincy, following in a graphic address on the "Coal Distribution Record System," with illustrations of board systems. By those systems the coal was put into service much

quicker, which was a considerable saving in the use of sub-bituminous coal. Mr. Ralph Bradley spoke at considerable length on the "Human Fireman," and approved of theoretical training going hand in hand with practical work. Mr. Bradley dwelt forcibly on the need of having new men trained under the very best crews in the division.

Mr. A. G. Kinyon, recently appointed chief consultant of the Board of Engineering Research Power Generation on Steam Locomotives for the Powdered Coal Engineering & Equipment Company, Chicago, spoke on the influence of an intimate knowledge of coal on fuel economy efforts of enginemen and others. Mr. Kinyon made some practical demonstrations, showing the elements of coal and combustion and how coal could be burned with the greatest degree of efficiency.

The meeting was conceded to be the most interesting that the association had yet held. Sixty-eight new members were admitted, making a total of 636.

The election of officers resulted as follows: President, W. H. Averell, general manager, New York properties, B. & O.; vice-presidents, E. W. Pratt, assistant superintendent of motive power and machinery, C. & N. W.; L. R. Pyle, fuel supervisor, M. S. P. & S. S. M., and W. L. Robinson, supervisor fuel consumption, B. & O. The following were elected to the executive committee: for two years—A. N. Willsie, C. B. & Q.; T. Duff Smith, G. T. P.; R. R. Hibben, M. K. & T.; Ralph Bradley, B. & M.; C. M. Butler, A. C. L.; for one year—William Schlafge, Erie, and W. K. Kilgore, C. H. & D.

Chicago was again selected as the next meeting place.

### The Railway Mechanical Conventions.

The principal events of June that are particularly interesting to railroad men are the annual conventions of the Master Car Builders and of the Railway Master Mechanics' associations which this year will be held in Atlantic City, N. J. The headquarters of both associations is the Marlborough-Blenheim Hotel. The Master Car Builders' convention comes first this year and will cover June 14, 15 and 16. The president of this association is Mr. D. R. McBain, superintendent of motive power of the New York Central Railroad.

The proceedings of the Master Mechanics' Association will occupy the days of June 19, 20 and 21. Mr. E. W. Pratt, assistant superintendent of motive power of the Chicago & Northwestern Railway, is president of this association.

Both the associations have laid out an exhaustive list of reports to be read and discussed, both organizations displaying vital signs of continued progress in keeping informed on the subjects that railroad people are most keenly interested in.

### Safety on American Railways.

All railway safety records were broken in 1915, when 325 American roads reporting to the Bureau of Railway News and Statistics, operating 161,948 miles of line, went through the entire fiscal year to June 30 without a single fatality to a passenger in a train accident. No such record of safe operation has been approached by the railways of any other country in the world.

All American roads in 1915, with over 250,000 miles of line, reported only 196 passengers killed in all railway accidents. Latest returns for Europe as a whole, with only 197,015 miles, show 700 passengers thus killed. When in 1901 the British roads alone went through the year with a clean record as to passenger fatalities in train accidents, the fact was heralded around the world as a marvel of safe train operation, and was used to the disparagement of American railways, though the latter were operating ten times as many miles of line.

### Railway Signal Association Meeting.

The semi-annual meeting of the above association, of which Mr. W. J. Eck is president, was held last month in the Hotel Astor, New York, and lasted two days. The most important report read and discussed was that on Signalling Practice, which was a revised statement of the purposes of and the requisites of installation for switch indicators.

The committee on Mechanical Interlocking presented a revision of the specifications for interlocking. Mr. W. H. Elliott called attention to the necessity for changes in pipe equipment. He also referred to the satisfactory use of iron in insulation of wires.

The special committee on Electrical Testing submitted a sketch illustrating two methods of relay post numbering and requested an expression by letter ballot on five questions: 1. Should relay posts be marked? 2. Should the letter scheme be used? 3. Should the number scheme be used? 4. Should corresponding numbers or letters be shown on wire tag or relay box? 5. Should the committee include such tagging in the general plan?

This association throws light upon many questions that are of vital interest to trainmen and station employees.

The term pig iron originated in a curious way. When iron is melted it runs off into a channel called a sow, the lateral branches of which are called pigs. Here the iron cools and is called pig-iron.





"I always thought," said Old Jerry as he sniffed at the particularly bad odor of a salesman's cigar, "that nothin' was as rank as the stuff some roads use on the front ends of their locomotives.

"It used to gag some of the boys," continued Jerry, "the first day it was put on and, believe me, those days came thick and fast. The blamed stuff burnt off almost as soon as it was put on.

"No, I never had any trouble on Old 689. I always used a Dixon Graphite preparation—some of the boys likes a natural gray and some a black finish and some likes a powder and others a paste—Dixon makes 'em all. Sweet and clean and always lasted from six to nine weeks.

"Sure you can get a testin' sample. Write as I did and ask for folder and free sample No. 69."

**Joseph Dixon Crucible Company**

Established 1827

**JERSEY CITY, N. J. 2-F**

#### Railroad Equipment Notes.

The Chesapeake & Ohio has issued inquiries for 25 to 50 Mallet type locomotives.

The Pere Marquette has ordered 15,000 tons of rails from the Algoma Steel Corporation.

The New York Railways Company has ordered 70 steel cars from the Southern Car Company.

The Norfolk & Western has ordered 18,000 tons of rails from the United States Steel Corporation.

The Lake Terminal has ordered 4 switching locomotives from the Baldwin Locomotive Works.

The Western Maryland has ordered 1,200 tons of bridge material from the McClintic-Marshall Company.

The Pennsylvania Railroad has ordered 75 Mikado type locomotives from the Baldwin Locomotive Works.

The Canadian Government Railways have ordered 30 locomotives from the Canadian Locomotive Company.

The Chicago & North Western has ordered 1,000 34-ft. wooden box cars from the American Car & Foundry Company.

The Louisville & Nashville will build 1,000 40-ton box, 500 50-ton gondola and 100 50-ton furniture cars in its own shops.

The Milwaukee Electric Railway & Light Company has ordered 100 M type trucks from the Baldwin Locomotive Works.

The Italian State Railways have ordered 2,000 gondola cars, and 1,000 box cars, from the American Car & Foundry Company.

The Hermstoltz Company of Rio de Janeiro, has ordered 3 four-wheel locomotives from the American Locomotive Company.

The California & Oregon Coast, Grants Pass, Ore., has recently ordered 13 41-foot, 40-ton flat cars and 2 36-foot, 40-ton box cars.

The Chicago, Burlington & Quincy has ordered 600 steel channels and center sills, 286 tons, from the Western Steel Car & Foundry Company.

The Chicago & Eastern Illinois has arranged with the Illinois Steel Company for the delivery of 10,000 tons of 90-lb. rails in the spring of 1917.

The St. Louis Southwestern has ordered 20 locomotives from the Baldwin Locomotive Works. This order included 12 Consolidation and 8 10-wheel locomotives.

The Great Northern will add 10 stalls to its roundhouse and will construct a cinder pit and turntable, to cost \$900,000, including incidental improvements at Breckenridge.

The Cuban Central Railways have issued inquiries for 50 30-ton flat, 150 30-ton box, 10 30-ton caboose, 100 25-ton flat, 50 15-ton narrow gauge box, and 5 15-ton narrow gauge flat cars.

It is reported that the Southern Railway has revised specifications on 2,250 cars recently ordered. These cars will have wooden underframes. The change from steel has been made in order to secure earlier delivery.

The Bessemer & Lake Erie, Union Railroad and other subsidiaries of the United States Steel Corporation are reported to have placed contracts for about 15,000 tons of 125 to 150-lb. rails with the Carnegie Steel Company.

It is reported that the Russian government is to revive its inquiry for 10,000 or more cars. The fact that two New York bank officials are on their way to Petrograd is believed to be the foundation for new interest in this inquiry.

The Terminal Railroad Association of St. Louis has ordered 12 6-wheel switching locomotives from the American Locomotive Company. Cylinders will be 22½ by 30 inches, driving wheels 51 inches, total weight in working order, 50,000 pounds.

The Canadian Government Railways are reported ordering 20 second-hand sleeping cars, 10 second-hand tourist cars and 1 second-hand dining car from the Pullman Company, and a number of second-hand coaches from Hotchkiss, Blue & Company.

The Trustees of the Cincinnati Southern have authorized the issuing of \$500,000 bonds, part of the proposed \$2,500,000 issue for the building of the Ohio River bridge. This money will be used for preliminary work in the construction of the bridge between Cincinnati, Ohio, and Ludlow, Ky.

The Lehigh Valley has announced plans for the placing in commission of 8 small repair shops at important points on the system. Orders have been placed for a supply of planers, lathes, boring mills, shapers and other tools used in the mak-

ing of light repairs to locomotives. These will cost about \$100,000.

The Lake Superior & Ishpeming has ordered 3,500 tons of rails from the Illinois Steel Company. It has also placed orders with the Lackawanna Steel Company for May, 1917, delivery for 3,500 tons of 85-lb. rails, 9,800 pairs of angle bars, 9,800 Abbott joint plates, 1,300 kegs of spikes and 350 kegs of bolts.

The Terminal Railroad Association of St. Louis was reported a month ago as having ordered 12 6-wheel switching locomotives from the American Locomotive Company. These locomotives will have 22½ by 30-in. cylinders, 51-in. driving wheels, a total weight in working order of 200,000 lb., and will be equipped with superheaters.

Estimates of the Canadian department of railways, recently passed by the supply committee of the house of commons at Ottawa, include \$3,000,000 to continue the building of the Hudson Bay line and its terminals at Port Nelson, and \$1,500,000 for work on the National Transcontinental. It is estimated that before the first named is completed in 1917 it will have cost \$26,000,000.

The Maine Central has ordered 8 locomotives from the American Locomotive Company. The order includes 6 Mikado type engines with cylinders 26½ by 30 inches, driving wheels 63 inches, total weight in working order, 275,000 pounds, and 2 6-wheel switching engines with cylinders 21 by 28 inches, driving wheels 51 inches, total weight in working order, 166,000 pounds.

The Boston & Maine has ordered 60 locomotives from the American Locomotive Company. The order includes 10 Pacific type engines, with cylinders 22 by 28 inches, driving wheels 73 inches, and total weight in working order, 233,000 pounds; 25 Consolidation type engines with cylinders 24 by 30 inches, driving wheels 61 inches, and total weight in working order, 211,000 pounds; 23 6-wheel switchers with cylinders 19 by 26 inches, driving wheels 51 inches, and total weight in working order, 145,000 pounds; 2 8-wheel switching locomotives with cylinders 25 by 30 inches, driving wheels 57 inches, and total weight in working order, 240,000 pounds.

#### Deceptive Stationary Signals.

There are few trainmen who can't look back with a hearty laugh to some comical experience of his own or his comrade's, where someone has mistaken something else for another train or for a danger signal. The moon has fooled many engineers and will continue to re-

peat the threat of danger every time she gets full. Men have stopped repeatedly and sent out a flag against a star that was peeping over the horizon right between the rails; and all of us have laughed over the Pennsylvania Dutchman who was running a second section of a train, on coming suddenly upon a pair of red lights slowed down to three miles an hour, and followed a canal boat till daylight.

A few years ago the writer was firing for a genius who was sure to find all the will-o-the-wisps that were out. One night we doubled an elbow rather suddenly and a bright headlight shone in our faces, looking as if it were not more than half a mile away. The old man jumped down, reversed the engine, began pulling the sand lever and whistled for brakes. "Brewster, my boy," he exclaimed, "get that red light and stop that train. Tell them to back to that siding, quick." The boy grabbed the light and ran for the point of danger, but soon the alarming headlight disappeared. Soon a whistle call sounded to recall the flagman, and the flagboy on returning found all the train crew in the engine cab discussing the cause of the disappearance of the light that had caused so much alarm. Then we proceeded cautiously and again the light flashed up. When we came near to its gleam we discovered it to be the light from a new blast furnace that had been blown in the previous day.

#### Safety First.

"Will you please tell me if the three-fifteen train has gone yet?" she asked, in apparent concern.

"Yes, about twenty minutes ago," he replied.

"And when will the four thirty be along, do you think?"

"Why, not for some time yet, of course."

"Are there any expresses before then?"

"Not one."

"Any freight trains?"

"No."

"Nothing at all?"

"Nothing whatever."

"Are you quite sure?"

"Certainly I am, or I wouldn't have said so."

"Then," said the timid woman, turning to her husband, "I think we'll cross the tracks, William."

#### Value of Learning.

Teacher: I wonder what your mother would say if she knew how backward you are in geography?

Girl: Oh! my mother says she never learnt jogfry and she's married, and Aunt Sally says she's never learnt jogfry and she's married, and you did learn jogfry and you ain't married!—"The Railway Conductor."

# GOLD Car Heating & Lighting Company

Manufacturers of

ELECTRIC,  
STEAM AND  
HOT WATER  
HEATING  
APPARATUS  
FOR RAILWAY CARS  
VENTILATORS  
FOR PASSENGER  
AND REFRIGER-  
ATOR CARS  
ACETYLENE SYSTEM  
OF CAR LIGHTING

Send for circular of our combination PRESSURE AND VAPOR SYSTEM OF CAR HEATING, which system automatically maintains about the same temperature in the car regardless of the outside weather conditions.

Main Office, Whitehall Building  
17 BATTERY PLACE  
NEW YORK

# Hydraulic

**Riveters Fixed and Portable  
Punches, Shears,  
Presses, Lifts, Cranes  
and Accumulators.**

**Matthews' Fire Hydrants,  
Eddy Valves  
Valve Indicator Posts.**

**The Camden High-Pressure Valves.**

## Cast Iron Pipe

**R. D. Wood & Company**

**Engineers, Iron  
Founders, Machinists.**

**100 Chestnut St., Philadelphia, Pa.**

## Nichols Transfer Tables Turntable Tractors

**GEO. P. NICHOLS & BRO.  
1090 Old Colony Bldg. CHICAGO**

## For Testing and Washing Locomotive Boilers

USE THE

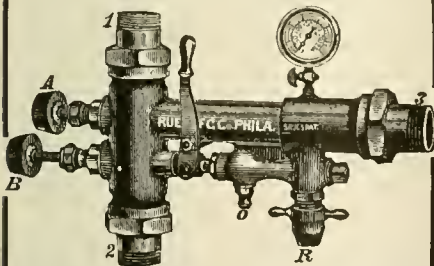

## Rue Boiler Washer and Tester

SEND FOR CATALOGUE

**Rue Manufacturing Co.  
228 Cherry Street Philadelphia, Pa.**

Manufacturers of Injectors, Ejectors,  
Boiler Washers and Testers, Boiler Checks,  
Check Valves.



## ASHTON POP VALVES AND GAGES

The Quality Goods That Last

The Ashton Valve Co.  
271 Franklin Street, Boston, Mass.  
No. 174 Market St., Chicago, Ill.

# Books, Bulletins, Catalogues, Etc.

**RISE OF RAIL POWER IN WAR & CONQUEST,  
1833-1914.** By Edwin A. Pratt. Pub-  
lished by J. B. Lippincott Company,  
Philadelphia, Pa.

The transcendent importance of rail-  
ways in modern warfare is fully set forth  
in this book. The painstaking author has  
culled his facts from the experience of  
nearly a hundred years, and reviews  
briefly, but clearly, the advantages of or-  
ganized systems of railways for military  
purposes. That Germany with all its per-  
sistent preparedness has been met by  
equal skill on the part of the French, is  
clearly proven, and on every side it is  
clearly shown that the management of  
the railways must be left in the hands of  
the railway men. It is a noteworthy fact  
that Belgium was the first power in Eu-  
rope to systematize the railways for the  
purpose of natural defense as well as for  
the industrial development of her re-  
sources, and the American Bureau of  
Railway Economics is frequently quoted  
among the highest authorities on the sub-  
ject. The book is a notable contribution  
to the history of our time, and important  
lessons may be learned from it in our  
preparedness for national defense.

**OIL FUEL EQUIPMENT FOR LOCOMOTIVES  
AND PRINCIPLES OF APPLICATION.** By  
Alfred H. Gibbings. Published by  
Constable & Company, London, Eng-  
land.

The principles of combustion as applied  
to oil-burning locomotives are fully ex-  
plained in this book of 125 pages. There  
are 42 illustrations, showing compressed  
air jet, and pressure jet systems. These  
are fully described. Burners, fire-boxes  
and draughts are enlarged upon, and  
tables and diagrams show their effect on  
the efficiency of the locomotive. The  
work is written in a clear and practical  
manner and will be welcomed by all in-  
terested in the use of oil as fuel in the  
modern locomotive. Price, \$2.00.

**RAILWAY CARRIAGE AND WAGON BUILD-  
ER'S POCKET BOOK AND DIARY, 1916.**  
Published by the Locomotive Com-  
pany, London, England.

A marked departure from ordinary  
practice has been the chief feature of  
British railway carriage during 1915. The  
mobilization and equipment of the army  
has shown a demand for vehicles of new  
types. For this and similar reasons this  
useful pocket book and diary will com-  
mend itself to railway officers and em-  
ployees of many grades. The contents  
include a large amount of data relating  
to railway car and wagon construction.  
Price 75 cents.

## The Moon Bill.

The Moon Bill is all moonshine. The  
car-mile rate in the Moon rate in the  
Moon Bill is based on an average loading  
of a little over 2 tons per car. This would  
not be a fair rate for carrying 10 or 20  
tons in a car. Nothing quite so unjustly  
preposterous was ever submitted to a  
legislative body, yet our legislators con-  
tinue to haggle over it. The reply of the  
railroads, published in pamphlet form, is  
so convincing that it does not require a  
moment's consideration. The carrying of  
the mails in the United States today by  
the railroads is simply highway robbery,  
and the Moon Bill would make it worse.  
Surely, a day of reckoning is at hand.  
Send for a copy of the statement made by  
the railroads to the Post Office Depart-  
ment to Mr. J. E. Fairbanks, secretary, 75  
Church street, New York, and see what  
injustice the railroads have to endure.

## A Wish and Its Fulfillment.

Under the above heading the editor of  
"Drill Chips," the organ of the Clevel-  
and Twist Drill Company, has published  
in pamphlet form the masterly article on  
"Preparedness," which we received last  
month, and advised the editor to repub-  
lish in compact form. This has been done,  
and an extensive edition is being distrib-  
uted to those who desire a copy. This  
is enterprise of the right kind. It em-  
bodies an industrial survey of our na-  
tion's producing facilities on a scale never  
before attempted. The proposed survey  
is not only feasible, but the plans for its  
accomplishment are already in the hands  
of a national committee. Copies of the  
unique pamphlet may be had from the  
Cleveland Twist Drill Company, Clevel-  
land, Ohio.

## Dixon's Graphite Products.

Lubricants have reached a degree of  
perfection hitherto unknown because an  
enterprising American company have  
given intelligent attention to the needs  
of every kind of service to which lubri-  
cation is an essential requisite, among  
which the proper lubrication for brake  
cylinders of the air brake system is one  
of great importance. The graphite at-  
taches itself to the irregularities in the  
metal surfaces and fills the pores of the  
leather, thereby making a graphite-to-  
graphite contact with the result that fric-  
tion losses are reduced to the very mini-  
mum, and insures ready and positive  
response to air pressure reduction. At the  
same time the graphite helps to retain the  
oil which was incorporated in the leather  
by the manufacturer. The lubricant is un-  
affected by wide ranges of temperature  
variations or by extreme variations of cli-

matic conditions. It is unaffected by water or moisture, and does not go into emulsion and readily wash away as many other lubricants do. Actual tests have proven that Packing Leathers are kept in pliable condition for a long time. In sending for a copy of "Graphite," also ask for a sample of the material itself, to the Joseph Dixon Crucible Company, Jersey City, N. J.

#### Solid Wrought Anvils.

The Hay-Budden Manufacturing Company, Brooklyn, N. Y., is a shining example to manufacturers in metals generally and railway supply firms particularly. As soon as the depression that followed the tariff changes were overcome partly by the exigencies of the European war, and partly by the indomitable spirit of American enterprise, the firm met the situation as it should be met. There was no delay in filling their rapidly increasing orders. Large additions to the company's appliances were installed at once and the working force increased to meet the demand, and the orders that crowded in were not received contingent upon delivery next year or even next month. All sorts and sizes of anvils are ready to pick and choose from, and whether the order is from across the Mississippi or from across the street, the goods are delivered with the promptitude of a United States cigar store. The designs and quality are of the best. The prices defy competition. The patterns are just right. For full information send for a copy of the company's catalogue to the main office, 254-278 North Henry street, Brooklyn, N. Y.

#### Seamless Steel Tempering Pots.

The National Tube Company has just issued an illustrated Bulletin descriptive of the Shelby seamless steel tempering pots. The superior merits of this type over others are widely recognized, and can be seen at a glance. From plates of open-hearth steel the plate is first sheared off in the shape of a disc, then heated and placed under a powerful hydraulic press and formed into the shape of a shallow cup. Again heated and pushed through a smaller die, which deepens the shape, elongating the sides, and leaving the bottom thicker than the rest of the body. The side walls are exactly uniform in thickness. Blow or sand holes are impossible. Irregularities are never found. The sizes are various, to suit the drills, saws, files, gears and other tools where they are raised to the proper temperature in boiling lead previous to immersion in oil, salt water or acid, by which means the proper temper is secured. Specifica-

tions and prices may be had from the company's main office, Frick Building, Pittsburgh, Pa.

#### Summer Travel Literature.

The variety of annual booklets just issued by the railroads for free distribution are more gorgeous than ever. They cover the widest possible range, and suggest trips to meet every imaginable taste. These publications may be had for the asking at any of the Travel Bureaus or passenger departments of the railroads. The immense increase in summer vacationists last year already dwindles in the prospect of the season just opening. If the European war accomplishes nothing else it has at least induced Americans to look at their own country, and all the scenic attractions of the old world are found to pale into insignificance as compared with the dazzling beauties of the peerless panorama of America's wonderlands.

#### Long Island Railroad Posters.

That there were no lives lost on railroad crossings on the Long Island Railroad last year was owing largely to the amazing display of posters warning the automobilists to come to a dead stop at all such crossings. This year the flaming posters are more flamboyant than ever. In a splendor of red, orange and black, these words are blazened so that he who runs may read, but he who stands still may read better. They are more startling than a revolver in the hands of a Deputy Sheriff, and if the suicidal mania of flying into the jaws of death is not stopped in Long Island it will not be the fault of the Railroad company. Other roads should follow the example.

#### Rio Grande Leaflet.

"Bandelier National Monument and a Summer in Pajarito Park Amidst the Prehistoric Aboriginal Ruins of Northern New Mexico" is the subject of an artistic 8-page illustrated leaflet issued by the Denver & Rio Grande R. R. Ruins and relics of a vanished race, that are in evidence along the line of that road near Santa Fe, N. Mex., are described and pictured.

#### Effective Advertising.

"Waiter," grumbled a customer, "I should like to know the meaning of this. Yesterday I was served with a portion of pudding twice this size."

"Indeed, sir," rejoined the waiter. "Where did you sit?"

"By the window."

"O, that accounts for it. We always give the people by the windows large portions. It's a good advertisement."

**STEEL STAMPS**  
INSPECTORS HAMMERS  
Hand Cut STEEL LETTERS & FIGURES  
LATHE TOOLS, TIME CHECKS,  
Noble & Westbrook Mfg. Co.  
8 ASYLUM ST. HARTFORD, CONN.

### Locomotive Engine Running and Management

By ANGUS SINCLAIR

This popular book has been a **RELIABLE REFERENCE** and comfortable **unfailing POCKET EDITION.**

PRICE, \$2.00

**ANGUS SINCLAIR CO.**

114 Liberty St.,

New York



#### The Armstrong Automatic Drill Drift

IS DRIFT AND HAMMER COMBINED.



The handle or driver is always ready to strike a blow as the spring automatically throws it back into position.

LEAVES ONE HAND FREE TO SAVE THE TOOL.

Special Circular Mailed on Request.  
**ARMSTRONG BROS. TOOL COMPANY**  
312 N. Francisco Ave., CHICAGO, U. S. A.

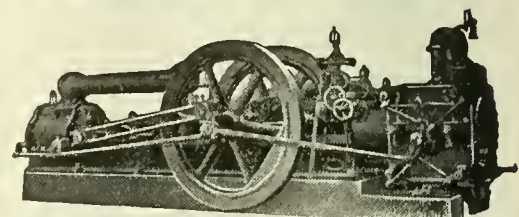

### The Norwalk Iron Works Co.

SOUTH NORWALK, CONN.

Makers of Air and Gas Compressors

For All Purposes

Send for Catalog

# Railway AND Locomotive Engineering

A Practical Journal of Motive Power, Rolling Stock and Appliances

Vol. XXIX.

114 Liberty Street, New York, July, 1916.

No. 7

## Important Advance in Railway Electrification

The change from steam to electricity which is making its way slowly has seen its most brilliant exploit on the Chicago, Milwaukee & St. Paul Railway, which has many great pioneer achievements to its credit. It is the first project of its kind where electric locomotives were in-

four steam engine divisions were selected for electrification, aggregating 440 miles in length.

Steam engines were first abandoned on the Three Forks-Deer Lodge Division, 115 miles long, and crossing the main Continental Divide, thus giving the elec-

trically operated road. By the first of November, 1916, it is expected that steam engines will be superseded over the entire distance of 440 miles from Harlowton, Montana, to Avery, Idaho.

This project is the most extensive steam railway electrification in the world,



ORE TRAIN ON THE BUTTE, ANACONDA AND PACIFIC RAILWAY HAULED BY 2 80 TON 2,400 V. D. C. LOCOMOTIVES, AND FREIGHT TRAIN ON THE CHICAGO, MILWAUKEE AND ST. PAUL RAILWAY HAULED BY 3,000 V. D. C. LOCOMOTIVE

stalled to operate over several engine divisions. The tracks over the mountain district represent the solution of one of the most difficult problems ever mastered by railway engineers. Out of this section of rugged mountain railway, including many long grades and short radius curves,

trical equipment its initial tryout under the severest service conditions of the entire system. The first electric locomotives were placed in regular service on December 9, 1915, and during the month of April, 1916, service was extended to Harlowton, making a total of 220 miles

the length of haul being nearly six times as great as any trunk line now operating with electric locomotives. The length of track between Harlowton, Montana, and Avery, Idaho, is approximately equal to that from New York to Buffalo or from Boston to Washington.

The passenger service consists of two all-steel finely equipped transcontinental trains in each direction, the "Olympian" and "Columbian," and a local passenger train in each direction daily between Deer Lodge and Harlowton.

Freight traffic through the electric zone

Regeneration, or the recovery of energy on the descending grades, by reversing the function of the electric motors reduces the cost of operation and furnishes a ready solution of the difficult braking problem. On the long sustained grades encountered in crossing the three

eral power plants of the Montana Power Company; transmission of 100,000 volts, three-phase, 60 cycles; conversion in substations to 3,000 volts direct current and distribution over extending overhead construction to electric locomotives. The modern Mallet steam locomotive weighing 278 tons with tender, which has been released, has a traction force of 76,000 pounds, while the electric locomotive weighing 282 tons, has a running traction force of 85,000 pounds, or a starting traction force of 136,000 pounds.

There are 42 of these main line locomotives (30 freight and 12 passenger) and two switching locomotives. The locomotives are the first to be used for railroad service with direct current motors operating at a potential as high as 3,000 volts and the first to use direct current regeneration. The passenger locomotives are equipped with a gear ratio permitting the operation of 800 ton trailing trains at speeds of approximately 60 miles per hour on tangent level track. The average passenger train weighs from 650 to 700 tons and is hauled over the two per cent. grade without a helper. The freight locomotives are designed to haul a 2,500-ton trailing train at approximately 16 miles per hour on all grades up to and including one per cent. On two per cent. grades the trailing load was limited to 1,250 tons, although this figure has been exceeded in actual operation.

Each locomotive is equipped with eight Type GE-253-A, 1,500-volt motors, insulated for 3,000 volts to ground. This motor has a normal one hour rating of



GENERAL VIEW GREAT FALLS DAM AND POWER HOUSE AT VOLTA, 4-10,000 K. W. VERTICAL GENERATORS FEED.

comprises from four to six trains daily in each direction. Westbound, the tonnage is made up of manufactured products and merchandise for Pacific Coast points and foreign shipment. Eastbound tonnage includes grain, lumber, products of the mines and some live stock.

As a large part of the traffic is through freight, trains are made up of an assortment of foreign cars, including box and flat cars, coal and ore hoppers, stock cars, refrigerators, etc., varying in weight from 11 to 25 tons empty and as high as 70 tons loaded. These cars being owned by many different railway systems are equipped with air brakes adjusted for different conditions of operation, and in accordance with different standards as to braking power and type of equipment, thus making the problem of holding the long trains on the heavy down grades by air brakes, a most difficult one.

During initial operation on the Rocky Mountain Division, the capacity of the new locomotives has been thoroughly tested. Trains of 3,000 tons trailing have been hauled east and 2,800 tons west, using a helper on the heavy grades. From the operating data obtained on the first division, it is evident that much heavier trains can be hauled with the electric locomotives than with steam engines, and all passing tracks are being lengthened to take advantage of longer trains. On some of the runs where the grades are less than one per cent. trains of as many as 130 cars and as heavy as 4,000 tons have been hauled with a single locomotive.

mountain ranges, great skill is required to handle either the heavy and varied freight or the high speed passenger trains with the usual air brakes. The entire energy of the descending train must be dissipated by the friction of the brake shoes on the wheels, and it approximates

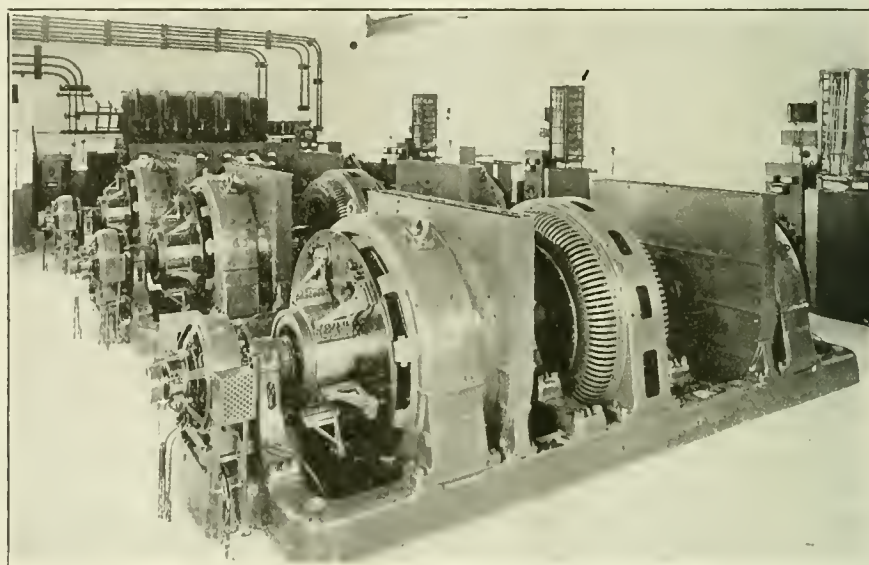

3-1,500 K.W., 3,000 V. D. C., 2,300 V. A. C. SYNCHRONOUS MOTOR GENERATOR SETS, PIEDMONT SUB-STATION.

3,500 kw. or 4,700 h.p. for a 2,500-ton train running at 17 miles per hour on a two per cent. grade, thus explaining why brake shoes frequently become red-hot and other serious damage is done.

The scheme of electrification includes the generating of electricity from the sev-

430 h.p. and a continuous rating of 375 h.p., so that the locomotive power plant has a normal one-hour rating of 3,440 h.p. and a continuous rating of 3,000 h.p. Each motor is twin geared to its driving axle in the same manner as on the Butte, Anaconda & Pacific, the Detroit River

Tunnel, and the Baltimore & Ohio locomotives, a pinion being mounted on each end of the armature shaft. Additional flexibility is obtained by the use of a spring gear and a spring nose suspension which minimize the effect of all shocks and also reduce gear wear to a minimum. The motor is of the commutating-pole type and is constructed with longitudinal ventilating ducts in the armature for forced ventilation from a blower in the cab.

The control equipment is the well-known Sprague General Electric Type M arranged for multiple unit operation. The main control switches are mounted in steel compartments inside the locomotive cab with convenient aisles for inspection and repairs. A motor-generator set in each half of the locomotive furnishes low-voltage current for the control circuits, headlights, cab lighting and for charging the storage batteries on the passenger coaches. Under steam operation, the charging current for these batteries is furnished by a steam turbo-generator set located on the locomotive. The blower for ventilating the traction motors is also direct connected to one end of this set.

The Montana Power Company, with whom the contract was closed for electric power, operates a network of transmission lines covering a large part of Montana, which are fed from a main plant at Great Falls, and a number of other widely separated water power plants of adequate capacity at all seasons of the year. A notable feature of this pioneer electrification is, therefore, the conservation of fuel consequent upon the utilization of water powers, which in that region may be said to be unlimited. They are distributed along the route at average intervals of 32 miles. Each station contains step-down transformers, motor-generator sets, switchboard and the necessary controlling and switching equipment. The transformers receive the line current at 100,000 volts and supply the synchronous motors at 2,300 volts. Each synchronous motor drives two 1,500-volt, direct current generators connected permanently in series, thus supplying 3,000-volt current for the locomotives. The fields of both the synchronous motors and the direct current generators are separately excited by small direct current generators direct connected to each end of the motor-generator shafts.

The overhead construction is of the modified flexible catenary type designed by the General Electric Company and installed under the direction of the Railway Company's engineers. With this quite novel but remarkably successful construction, the current is collected in both high speed passenger service and heavy freight service without any sparking.

The passenger and freight locomotives are identical, with the exception of gear

ratio and the addition of an oil-fired steam boiler in each half of the passenger locomotives for heating the trailing coaches. The two boilers are capable of evaporating 4,000 pounds of water per hour and this equipment with tanks for oil and water bring the weight of the locomotive up to approximately 300 tons. The interchangeability of all electrical and mechanical parts of the locomotives is considered of great importance from the standpoint of operation and maintenance.

These water power plants are so located at widely separated points that there is little probability of an interruption of the supply.

Available capacity of storage reservoirs in service is 447,150 acre feet, of which the largest, the Hebgen reservoir on Madison River, contributes 325,000 acre feet. There is a further undeveloped capacity of 78,500 acre feet.

#### French Locomotive.

It will be of interest to learn that on the Eastern Railway of France, or in that portion of it still in the hands of the French Government, there are a large number of locomotives of the older types still doing excellent service in the con-

of them having three crews. The recent supplies of railway material are the largest on record in France, and the army supplies are handled with a degree of promptitude that, perhaps, has never been equalled.

The general dimensions of the locomotive illustrated are as follows:

Cylinders, 17 $\frac{3}{8}$  ins. by 26 ins.

Diameter of wheels, 4 ft. 1 $\frac{5}{8}$  ins.

Steam pressure, 128 lbs.

Heating surface—Firebox, 89.23 sq. ft.; tubes, 1,811.82 sq. ft.; total, 1,901.05 sq. ft.

Grate area, 20.06 sq. ft.

Capacity of tender, 1,653 gallons.

Coal, 4 $\frac{3}{4}$  tons.

Wheel-base—Engine, 12 ft. 11 $\frac{1}{2}$  ins.; tender, 8 ft., 2 $\frac{1}{2}$  ins.

Length over buffers—Engine, 30 ft. 10 $\frac{3}{4}$  ins.; tender, 19 ft. 3 $\frac{3}{4}$  ins.

Weight in working order—Engine, 50 tons, 14 cwt., 2 qrs.; tender, 24 tons, 0 cwt., 1 qr.; total weight, 74 tons, 14 cwt., 3 qr.

#### Railroad Work in Alaska

Writing from Cordova, Alaska, a young railroad man states that he is employed

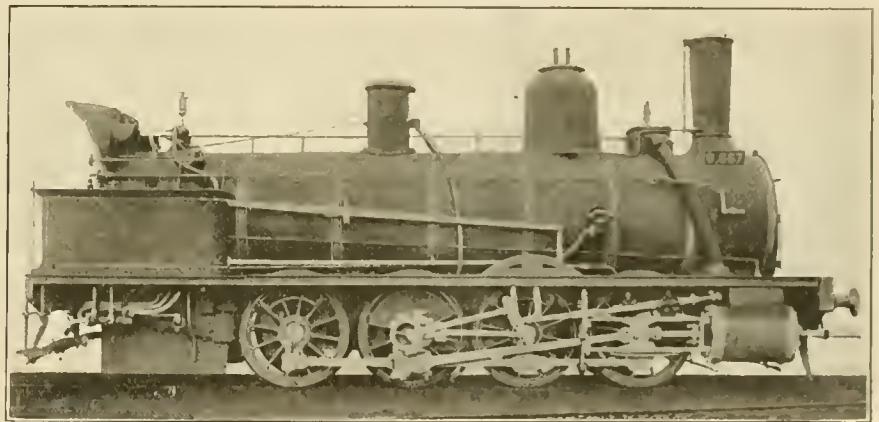

TYPE OF SWITCHING LOCOMOTIVES ON THE EASTERN RAILWAY OF FRANCE.

gestion of traffic consequent on the supply of material and munitions on the extended battle line. These locomotives, although not possessing high speed, are said to be reliable in freight traffic. The service may be said to be little more than that of a general switching kind, as the runs are comparatively short, but as the entire weight is on the driving wheels their adhesive qualities are of the best, and the roads are said to be in excellent condition. Near the front there are a large number of much smaller engines, running on narrow gauges, the rails being laid with great rapidity on such temporary tracks as may be necessary to meet the requirements of the service. Repair work on this type of locomotive is easy of accomplishment, and the engines are kept running day and night, many

as a brakeman and receives \$150 per month without any overtime. The winter has been very severe, although the climate is said to be usually mild, rarely going below zero. Last winter it was 15 degrees below zero for over a week. The writer, continuing, states that the interior gets much colder. Chitena, the end of our division, 130 miles north of here, it went down to 68 below for over a month. It was 25 below when we left there this morning, but a beautiful day here, 19 above. The people of the north know how to dress for this weather, however, and they do not seem to mind the cold so much. Winter started in the interior October 14 and it has not thought of letting up as yet. They say they have three seasons up there—July, August and winter, and I won't dispute it.

# Freight Brake Conditions

## More Damage Done to Freight Than Passenger Equipment

By WALTER V. TURNER, Assistant Manager Westinghouse Air Brake Co.

On the subject of passenger car brakes I have said a great deal in reference to smoothness of operation or a stop with the air brake without undue shock through slack action. It goes without saying that this is also of importance in freight brake operation as more damage is done to freight equipment and lading through rough handling or failure to control the slack action than there is in passenger equipment. It may not be amiss to repeat that uniform retardation on all cars in the train is the secret of the elimination of slack action and if all cars are retarded together there can be no difference in velocity set up in a short time to cause a violent closing or stretching of slack. However a uniform retardation is impossible in a mixed train made up of empty cars braking at 60 per cent and loaded cars braking at from 15 to 17 percent as the empty cars must do the braking for their own weight and part of that for the lading of the loaded cars. It is this difference in braking ratio which causes the slack to shift and the braking load to distribute between empty and loaded cars, and if the slack shifts suddenly, damaging shocks occur and the suddenness of the shifting depends directly upon the differences in braking ratio existing between the various cars in the train.

Uniform retardation, until the serial brake action has passed the full length of the train is, strictly speaking, impossible without electrical assistance, which is found in the electro-pneumatic brake. This eliminates the time element or serial action in applying the brakes on each successive car from the head end to the rear end and all brakes apply as on one car, but by applying the pneumatic brake cautiously, that is, with light brake pipe reductions and with due regard for conditions of slack, namely, train make up, curvature and profile of track and other local conditions, until all brakes are on, uniform retardation in a practical sense may be obtained in freight service. It necessitates, however, an empty and load brake.

An "empty car brake," "single cylinder brake," or to use perhaps the best name of all a "single capacity brake," is the one most generally found in railroad service today. It is one in which a constant braking force is used at all times or for all conditions of car loading and one for which the braking ratio is invariably based on the empty weight of the car. If we consider just what the range in braking ratio actually is when the car varies from its empty to its fully loaded

weight, we may find a car weighing 40,000 lbs. empty and braked at 60 per cent of this weight with 50 lbs cylinder pressure being used as a braking ratio basis. If the car has a hauling capacity of 110,000 lbs., and an overload margin of about 10 per cent, the total loaded weight becomes about 160,000 lbs., and the constant braking force, which was 60 percent of 40,000 lbs., becomes 40,000/160,000 of 60 percent or 15 percent of 160,000 lbs.

Other things being equal, the retardation set up is proportionate to the braking ratio, and it is inevitable that cars braked only one quarter as effectively as others should close up or pull away as the case may be, according to the relative positions in the train, that is to say, it is inevitable that slack action—violent slack action—should occur.

In an effort to counteract or remedy such effects, some railroads have jumped from the frying pan into the fire, or have made a bad matter worse by increasing the braking ratio on the empty car, which of course increases the braking ratio above 15 percent on the car when it is loaded, but it is so disastrous to braking operations with long trains that if railroad officials, who finally settle with the shipper for damage to lading and make good the losses due to damaged rolling stock, only knew what it means in dollars and cents, the business life of the individual responsible for such engineering would be in jeopardy.

While the railroads having grades to negotiate condemn the roads with only level districts because of the class and condition of brakes they turn over, it is my judgment that the level roads have just as strong a contention against the mountainous roads for turning over to them cars that have the empty car braking ratio raised so high, in order to better the braking ratio for loaded cars, that a condition already bad has been made infinitely worse in the way of slack action.

One of the great troubles of our railroad today is that they are run by departments and there is no unity of action among the different organizations of the railroads. As an example, the station agent does not think that he has any particular interest in air brakes, the superintendent and the management have some, when trouble occurs or when conditions get so bad that they cannot get very much worse, but when speaking of air brakes generally, there is no one outside of the engineering department of the railroad that pays very much attention to them. This should not be so as nothing definite is gained by air brake engineers

of a railroad pointing out certain requirements and deficiencies if they cannot secure the co-operation from other departments of the road. Anyone interested in air brake matters understands, in a general way at least, that there are some difficulties encountered in handling the long freight train of the present day, and after an accident anyone is able to tell just what the engineer should have done. Instruction is the proper thing as long as anything can be accomplished by means of instruction, but instruction is not the cure, it only deals with the effect instead of the cause, and as long as this is true somewhat more than instruction will be required to provide the improvement sought in brake operation on long freight trains.

I do not mean to say that a great deal of trouble cannot be avoided by proper maintenance, manipulation and instruction and the various ways we all adopt from time to time to eliminate trouble, but if the losses unnecessarily encountered through the operation of modern long freight trains are to be materially reduced, it is fundamentally necessary to make certain radical changes in brake mechanism for handling these trains.

This is intended merely as a preliminary article of a series of which will deal largely with the fundamental principles of air brake engineering in connection with railroad operation. If it were not for the air brake we could not buy the things that we buy at all, or at least only in a very smaller degree, because nothing can be brought to our doors that is not produced locally, without the railroad. Next to the locomotive the air brake is the most potential factor in railroad operation. It may seem strange, but it is a fact nevertheless and whenever the air brake in design and efficiency begins to meet the requirements of locomotive and car construction, the railroad engineer or the construction engineer goes a little further and builds a larger locomotive, a faster one, or a larger car. But this could not be done, that is, the improved locomotive could not be successfully used, if a brake capable of controlling the locomotive perfectly could not be developed, or, stated another way, if the improvements in air brake design did not keep pace with the requirements in railroad service.

Where grades have been the determining factor governing the amount of traffic that could be handled over a certain decision, heavier motive power and grade reduction have served to enlarge this "neck of the bottle" and provide for a greater



traffic volume. Vast expenditures have been made for grade and curve reduction, heavier locomotives, heavier rails, stronger bridges, better road bed and steel cars have reduced dead weight per ton capacity. All of these expenditures have been made with a view of increasing traffic capacity or volume of traffic and of reducing the operating expenses by running more trains composed of a greater number of heavier cars, and it has been followed so successfully that today Amer-

ican railroads handle freight at less than  $\frac{3}{4}$  of a cent per ton mile, a rate lower than any to be found in the entire world.

Now on how many level districts are long trains being handled without damage to lading and equipment due to slack action because retardation is not uniform between the empty and loaded cars in the train? On how many hilly districts are trains restricted in length, are hand brakes resorted to, are empty cars operated up and down each side of the grade

just to bring down the tonnage per brake to an operating point? Are engineers in fear and trembling when they tip the crest of a hill, all because safety in descending the grade is the limiting traffic condition?

Many times we look at damaged cars and broken draft gear and wonder how it happened, and in future articles an effort will be made to explain it and show the remedy for the conditions that produced the damage.

## Various Methods of Screwing in Staybolts

By GEORGE SIMS, Master Mechanic, Bethlehem Iron Mines Company, Cruz Grande, Chile

### Correct Method as Practised in the United States

By E. D. STAFFORD, General Manager, Flannery Bolt Company, Pittsburgh, Pa.

#### Question by Mr. Sims.

It would be very gratifying if you would give a reply through the medium of your valuable paper to the following question:—How should locomotive fire box stays be screwed in? Which of two methods would be preferable—to screw in a stay with a pressure something similar to screwing down a medium tight nut, with a pull of about 20 pounds at the end of a wrench about 15 inches long, or that of a pull of about 120 pounds on the end of a lever 36 inches long? Which method would be more economical? This is a point which I have often heard discussed in the boiler shops, and may state that the method in British shops is to screw in stays as tightly as possible, the idea being that the harder the stays were screwed in the better.

#### Reply by Mr. Stafford of the Flannery Bolt Company.

The usual practice in the United States is to obtain a fairly snug or neat fit of all staybolt threaded connections with straight threads. Good, full threads are required, and taps and dies are used that conform to within the allowable limits of variation that regulate and make this possible. Too light a fit might result in the tearing and stripping of threads, and too loose a fit would be liable to require calking after being riveted up, and also have a tendency to distort the threads. Staybolts are usually screwed in with a motor drill and then adjusted by wrenches when necessary. Crown stays with taper threads and riveted ends require full threads in sheet and bolt, and tapers that agree, and a tight fit to fill the taper before being riveted up. The button head crown stay should naturally obtain a tight taper fit, with full threads, with the button head bearing on the crown sheet in perfect agreement in order to obtain a perfect fit and a reliable support.

When new fireboxes are installed it is necessary, of course, to preserve the

parallel or natural relation of both sheets when applying staybolts, and the sheets are gaged at several points over the whole surface, by being bolted together through the drilled holes before the bolts are tapped, then the staybolts are inserted in certain rows along the sheet to hold the sheets in a natural position, when the tapping out of the entire sheet is then followed with less liability of springing, thus overcoming the chances of the threads not being in alignment. Threads that do not agree in the alignment of the pitch, at times are liable to tear or strip, and naturally screw in so tightly that the question arises whether the error is in the tapping or if the diameter of the bolts is too large, so that in order to obtain the right staybolt fit, much depends on following these several points.

The practice of putting in ordinary solid staybolts loose to obtain a certain amount of flexibility is not good practice. Such has been done at times, however, to reduce staybolt breakage, but the resulting damage to staybolt holes in sheets and the necessity of continual calking to stop leakages has, as a consequence, been condemned as unmechanical and the practice discontinued. In the act of riveting or heading up staybolts considerable force is exerted on the threads in both staybolt and sheet, so that a good neat fit would naturally serve to make a more intimate connection and preserve its tightness after hammering up than a looser fit, providing that the holding on bar is up against the staybolt to resist each blow of the hammer. Pneumatic hammers are now used quite largely to throw up the metal gradually, and they obtain a smooth riveted head with less shock to the materials.

Such is the general practice, but many shops have their own particular methods, and it would be interesting to hear from some of them in regard to the methods in vogue, although the whole proposition is, in the last analysis, one that depends on doing good work in the machining of

plates in order to obtain good full threads on accurate pitch alignment, and the threading of staybolts to uniform sizes that will agree with the tapping, and a resulting fit of staybolt in the tapped hole that screws up neatly without loosening.

#### Repairing Broken Lubricator Studs.

By F. W. BENTLEY, JR.

On the Bull's Eye type of lubricator the oil channel coring frequently runs well up into the stud, and a false one of sufficient size to hold the lubricator cannot be safely applied, being screwed into

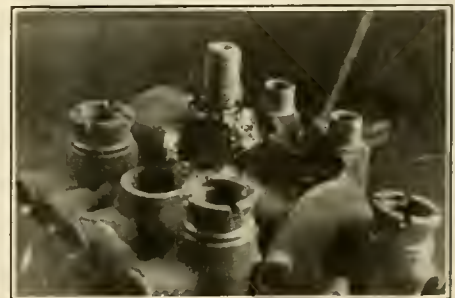

metal without necessity of a steam tight fit. The attached photograph shows how a false stud can be applied and made almost a solid part of the lubricator body again.

The remaining part of the old stud is cut off flush with the face of the boss rising from the back of the lubricator. It is then drilled out and the false stud screwed in as shown by illustration. By means of the oxy-acetylene flame, the boss of the body and the portion A of the stud are run and welded together completely around the stud. The portion of the stud entering the lubricator in no way interferes with the passage of oil to the pump, yet gives the welded parts a strong support in holding the weight of the lubricator. It is inexpensively done, and is an excellent method of repairing breakages of this kind on the lubricator.

# Annual Convention of the Master Car Builders' Association

The fiftieth annual convention of the Master Car Builders' Association was held at Atlantic City, N. J., June 14, 15, 16, President D. R. MacBain in the chair. In the course of an admirable opening address by the chairman, emphasis was placed on the results obtained by the work of the association, and he suggested that a resume of the work should be prepared in book form. Referring to the work of the committees, the chairman showed how carefully he had familiarized himself with the mass of details coming before the association. The progress during the year in complying with legislative enactments, especially on the leading railroads, was excellent, but there was still room for progress along this line. The standardization of brake equipment was urged, and the work of the committee



DONALD R. MacBAIN,  
President, Master Car Builders' Association,  
1915-16.

heartily approved. A revision of the interchange book of rules was urged, as a simplification was desirable. The chairman regretted a growing tendency in the use of non-standard material in the construction and repair of cars, and appealed to the members to correct this practice as far as it was within their power to do so. The growth of welding cast steel parts was referred to, and a recommendation that the committee be continued was urged. In referring to the twelve members who had died during the year, the chairman paid a glowing tribute to the memory of John Kirby, formerly master car builder of the Lake Shore & Michigan Southern Railway, who had been in railway service 61 years and seven months. He was one of the association's strongest advocates and supporters, and much of

what had been accomplished in the work in which the association had been engaged can be attributed to Mr. Kirby and others of his type. Attention was also called to the long and faithful services of Mr. Joseph W. Taylor, who had filled the office of secretary for 17 years, and previously assistant secretary for nine years.

The president's address was warmly appreciated, and after the secretary and treasurer had submitted their reports, considerable routine business was disposed of, the reports of the special committees were taken up and continued during the remainder of the sessions. These reports were unusually full, and called forth considerable discussion, but the reports and recommendations were almost in every case approved. The following are condensed reports of the most important subjects that came before the association:

## Train Brakes and Train Air Signals.

Among other changes recommended by the Committee, the location of angle cock, on end of brake pipe on freight cars, a new location was suggested with a view to reducing brake-pipe leakage through the hose coupling of long freight trains where draft gear travel is extended to its maximum, and also with the view to reducing angle-cock breakages. The location shown in the appended sketch would be a decided improvement in the standard location of the angle cock. Not only so but the coupler and carry iron have grown to such an extent that on the modern steel car it is impossible in many cases to adhere to the standard location. The elbow for air signal hose should follow the same inclination as that of the brake-pipe angle cock, and if so an improvement will be made on the hanging of the air signal hose, both when coupled together and when coupled with the dummy coupling.

The question in regard to the failure of cast iron wheels under refrigerator cars came up again this year, and a full explanation was presented by a number of leading manufacturers pointing to the irregularity of braking power in cars of various types, and if this were given careful consideration it is evident that much better results would be obtained than at present.

The Committee consisted of R. B. Ken-dig, chairman, B. F. Flory, J. M. Henry, L. P. Streeter, R. B. Rasbridge, W. T. Hartman, and A. J. Cota.

## Car-Wheels.

The Committee jointly with the Com-mittee on tracks of the American Railway

Engineering Association, considered the subject submitted to them. The subject was originally brought up by the Association of Manufacturers of Chilled Wheels, that association claiming that the strength of the chilled iron car wheel has not kept pace with the increase in the load, and that the wheels under cars, especially of the higher capacities, should have the flanges thickened. Much information was available in regard to broken wheels. In a number of cases the fracture extended in an almost perpendicular direction, and were distinctly tread failures. The Committees were unanimously of opinion that nothing will be gained in the interests of safety or economy by adding metal to any portion of the flange of cast-iron wheels in such location as will in any way affect track clearances. The Committee were unable to express an opinion as to whether the addition of metal to the back of the tread so as to increase throat thickness will afford

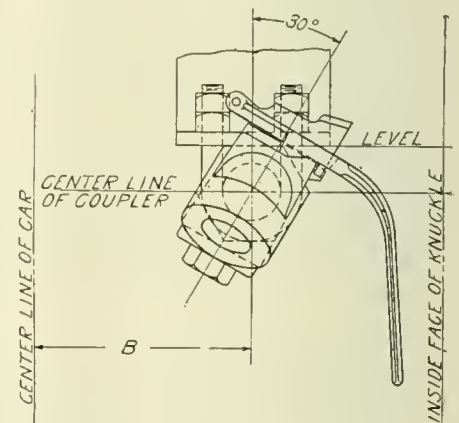

PROPOSED LOCATION OF ANGLE COCK  
ON FREIGHT CAR.

any relief. The subject of the shape and thickness of plate for cast-iron wheels is one that gives promise of leading to changes that will result in the reduction of plate failures, as experiments by the Pennsylvania Railroad are being made, and a report on the subject will be made next year.

The Committee consisted of W. C. A. Henry, chairman, A. E. Manchester, J. A. Pilcher, O. C. Cromwell, J. M. Shackford, H. F. Smith, and L. Brown.

## Brake Shoe and Brake Beam Equip-ment.

The most important subject considered by the Committee was the design and specifications for a standard No. 2 brake beam. The idea was to include the sus-pension of the brake beam and the brake

beam hanger, with a view of eliminating all safety hangers and the trouble that has been experienced with brake beam hangers. In view of the fact that the manufacture of No. 2 beams is now largely standardized and that certain proportions and dimensions are recognized as essential, and that it will undoubtedly be adopted by the American Railway Association as a part of the standard freight

force of 450,000 pounds caused the channel to be overstrained. On the heavier channels the maximum capacity was not reached for the lugs sheared at about 850,000 pounds. In two of the tests ten rivets were sheared off, and the committee recommended that a longer lug with more rivets in it should be provided.

The Committee embraced Prof. L. E.

is confidently expected by the Committee.

The Committee comprised D. R. MacBain, chairman, D. F. Crawford, C. E. Fuller, C. B. Young, H. Bartlett, H. T. Bentley and E. A. Sweeley.

**Welding of Cast Steel Truck Side Frames and Bolsters.**

W. O. Thompson, chairman, A. M. McGill, J. J. Hennessey, and Geo. W. Rink, of the Committee on the above subject reported that in their opinion cast-steel truck side frames must not be welded if cracks extend more than one inch from edge of any rib or flange. In the case of cast-steel bolsters they must not be welded if cracks extend more than one and a half inches from edge of rib or flange, unless bolster is reinforced at place of failure by addition of plates, either welded or riveted to bolster.

Mr. J. T. Wallis, member of committee, reported that he could not concur in the report of the majority in permitting welding of the parts referred to, for the reason that the fractures indicate weakness in design, and the welding will not add to the strength, but introduce a condition of further weakness. Many of these parts are failing as a result of weakness in design. Where the proper sections are used, these cracks do not appear.

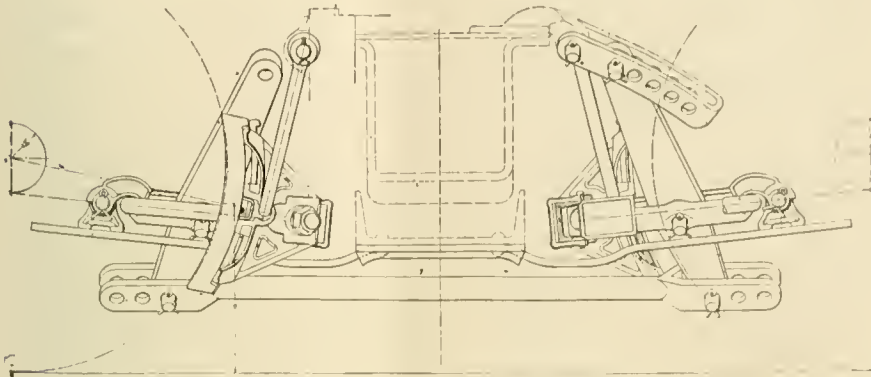

ASSEMBLED VIEW OF BRAKE BEAM AND SUSPENSION.

car equipment, the committee recommended the adoption of the proposed No. 2 brake beam, and also a change in the diameter of material in the hanger from 7/8 in. to 1 in. After October 1, 1916, the M. C. B. Standard No. 2 brake beams may be used in repairs to all freight-equipment cars, regardless of their light weight.

Purdue University has undertaken to make comprehensive physical tests of all No. 2 brake beams in common use, and members have been asked to contribute beams for this purpose.

The Committee comprised Prof. C. H. Benjamin, chairman, C. D. Young, R. B. Kendig, S. H. Bilty, and C. B. Young.

**Draft Gear.**

Through the courtesy of the Union Draft Gear Company, the Committee secured the use of their laboratory and their 15,000-pound pendulum hammer. This hammer is so equipped that it can be raised to any desired height and allowed to drop against a 30,000 pound car that rolls on a straight level track. Seven sets of channels were tested, five ordinary and two heavy sets. The channels were 12 in. deep, and five had a weight of 25 pounds per foot. The two heavy ones had a weight of 40 pounds per foot. The cover and tie plates were 5/16 in. thick. The gears selected were of different capacities. The law of physics, that force equals mass times of acceleration was employed and the acceleration of the car in feet per second obtained, and multiplying the acceleration by the mass gave the force. The maximum force on two 12 in., 25-lb. channels was approximately 600,000 pounds, but a

Endsley, chairman, W. E. Dunham, J. R. Onderdonk, A. R. Kipp, G. W. Rink, P. F. Smith, Jr., and J. C. Fritts.

**Safety Appliances.**

The progress made in the equipment of freight cars with safety appliances to comply with the law was reported as satisfactory by the Committee, and this in spite of the strenuous conditions with which the railroads have to contend. The report showed that 2,505,159 freight cars were in operation, of which 1,905,929 were put in service prior to July 1, 1911, and of the total number in operation 1,303,906 had been equipped with safety appliances. Of the cars built prior to July 1, 1911,

**Tank Cars.**

The increase in power and in the length of trains makes desirable a general stiffening up of the designs for car tanks in line with the practice in other classes of freight equipment cars, such revision, however, rather to be directed to the car requirements for cars built in the future than to those now in service. Tank cars may be divided into four classes, those built previous to 1903, which are principally wooden underframe cars, having been tested to but 40 pounds per square inch;—tanks built since 1903 requiring a test pressure of 60 pounds;—tanks for general purposes, to be built after a future date to be fixed; and insulated tanks for carrying highly volatile inflammable liquids such as casinghead gasoline, to be built after the future date fixed. In the first class referred to they can not be used for the transportation of inflammable liquids with flash points below 20 degrees F. The second and third classes are practically alike as being adapted for general use, excepting in the new specifications wherein the third and fourth classes the requirements as to material, riveting, and other details have been presented by the Association of Recommended Practice, and should be followed. In regard to the latter two classes, this Committee took a positive stand against the use of head blocks for securing the tank against longitudinal shifting. The center anchorage system,—the connection of the

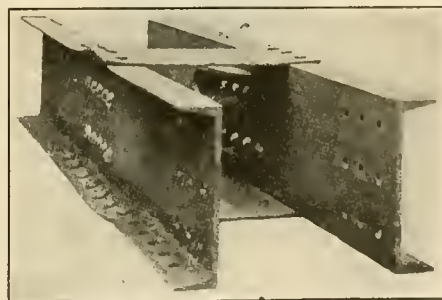

VIEW SHOWING CONDITION OF SILL AFTER TEST.

there remained to be equipped on December 31, 1915, 681,571 cars. To expedite the completion of the equipment it has been proposed that after January 1, 1917, no car will be received from owner unless properly equipped with United States Safety Appliances or United States Safety Appliance Standard. The co-operation on the part of the railroads

tank to the underframe at some point between the bolsters, has shown its superiority beyond any question. The Committee also deemed it unwise to transfer to steel underframes tanks built prior to 1903, which will not stand the 60-pound test pressure required in the case of tanks built since that time. The present specifications require that after January 1, 1918, all tanks in transportation service shall be subjected to the full test requirements of 60 pounds per square inch. Before that date there will be another meeting of the Association, and doubtless the subject will be further investigated. The Committee submitted a mass of details in reference to the requirements of the United States Safety Appliance Standards, and which will appear in the annual volume containing the proceedings of the Master Car Builders' Association.

The Committee on the subject consisted of A. W. Gibbs, chairman, C. E. Chambers, Wm. Schlafge, M. J. McCarthy, Samuel Lynn, Thomas Beaghen, Jr., and O. J. Parks.

#### Election of Officers and Committees.

The election of officers for 1916-17 resulted as follows: President, C. E. Chambers, superintendent motive power, Central Railroad of New Jersey; first vice-president, T. W. Demarest, superintendent motive power, Pennsylvania Lines West, Northwest System; second vice-president, James Coleman, superintendent car department, Grand Trunk; third vice-president, G. W. Wildin, mechanical superintendent, New York, New Haven & Hartford; treasurer, John S. Lenz, master car builder, Lehigh Valley.

Executive Committee: Samuel Lynn, master car builder, Pittsburgh & Lake Erie; J. C. Fritts, master car builder, Delaware, Lackawanna & Western, and C. B. Young, mechanical engineer, Chicago, Burlington & Quincy.

Nominating Committee: F. W. Brazier, superintendent rolling stock, New York Central Lines; D. F. Crawford, general superintendent motive power, Pennsylvania Lines West; D. R. MacBain, superintendent motive power, New York Central Lines West of Buffalo; C. E. Fuller, superintendent motive power Union Pacific, and M. K. Barnum, superintendent motive power, Baltimore & Ohio.

George N. Dow was elected life member.

#### Attendance at the Conventions.

The registration of members of the Master Car Builders, and Master Mechanics' Conventions, was the largest on record, the previous highest record being that of 1911, when 719 members were present. This year the members present were 754. There were also 722 special guests.

## Annual Meeting of the Railway Supply Manufacturers' Association

The Railway Supply Manufacturers' Association held its annual meeting at Atlantic City on Saturday, June 17, President Oscar F. Ostby in the chair. Among other business the question of forming two classes of members was discussed, one class embracing those who furnish exhibits and another for those who do not make exhibits. The matter was finally left in the hands of the executive committee. The following were elected as the new members of the executive committee: Second District, C. W. Beaver, Yale & Towne Manufacturing Company, and H. G. Thompson, Edison Storage Battery Company; Third District, Wm. McConway, Jr., McConway & Torley Company; Fourth District, G. A. Cooper, Frost Railway Supply Company; Fifth District, G. R. Carr, Dearborn Chemical Company.

The following were elected officers for 1916-17: President, Edmund H. Walker, Standard Coupler Company; vice-presi-

dent, the newly elected president, gracefully thanked his fellow members for the high honor paid to him in electing him to the office.

#### Among the Exhibits of the Railway Supply Manufacturers' Association.

It would be as difficult to describe with any degree of fairness and fulness the magnificent display of the finished products of the Railway Supply Manufacturers on the mammoth steel pier at Atlantic City during the two weeks in June, as it would be to describe the glowing panorama of the scenic splendors of New Jersey with its flower bespangled meadows and green mantled hills and rose-wreathed fields and vine-clad villas, and the foam-fringed and far spreading archipelago of the blue Atlantic with its emerald isles set in a sparkling sea. Indeed the change from the outward phenomena of nature to engineering art as exhibited on the steel pier garnished as it was in rainbow banners and woven tracteries of garlanded wreaths is not great. The decorations were superb. The finished products were set in burnished beauty and everything that the finest artistic taste could do to make the exhibition attractive had been accomplished by the painstaking hands of the expert supply men's committee. Other times and countries have seen triumphs in other departments of human endeavor, but surely this is the age of perfection in mechanism, especially in railway appliances from the huge locomotives down to the smallest appliance. They were all there at their best, and the additions that are made year by year are surprising, and the new forms and purposes of the endless variety of machines are an assurance that mechanical ingenuity is keeping pace with the requirements of the hour.

All were worthy of particular notice and the ever-varying crowds of visitors were keenly interested in the exhibits. As may be expected the latest improvements seemed to be the most attractive. Among these the locomotive stokers, including the Street, Crawford, Standard, and Hanna, received much attention.

The Ashton Valve Company showed several marked improvements in safety valves.

The Automatic Ventilator Company had working models of car ventilating devices that bid fair to revolutionize the ventilation of cars.

The Bird-Archer Company showed the details of methods of treatment in bad water districts and for which they are meeting with much popular favor.

The Boss Nut Company showed the complete solution of the lock nut prob-



OSCAR F. OSTBY,  
President, R. S. M. Association, 1915-16.

dent, Le Grand Parish, American Arch Company.

The number of exhibits this year amounted to 260, being 38 more than last year.

Mr. Ostby in the course of a fine address on retiring from the presidency paid a warm tribute to the work of the executive committee, and to the officers of the Master Car Builders' and American Railway Master Mechanics' associations for their active assistance and interest in the work of the exhibitors. The success of the exhibition was such that in every way it was the most popular in the history of the association, and there was every indication that an era of progress and prosperity unexampled in railway business was upon them. Mr. Ostby was presented with a past-president's badge, and Mr. Walker,

lem, a question that has puzzled many eminent inventors.

The Breakless Staybolt Company showed something new in staybolts that defies fracture.

The Buda switches showed the perfection of the elimination of backlash in switch stands for yard and main line service.

The Damascus Brake Company exhibited their latest marked improvements in brake beam construction.

The Dearborn Chemical Company showed their methods of water analysis that have had such complete success in eliminating foaming in boilers.

The Detroit Lubricator Company among other exhibits, showed an improved flange lubricator that is automatic in action at all times and independent of the engineer.

The Dixon Crucible Company showed their various compounds, particularly noticeable among which was the pipe joint compound which reduces time, labor and cost on pipe work.

The Galena Signal Oil Company had a fine exhibit of oils that have stood the test in every kind of service and the highest degrees of superheating temperatures.

The Gold Car Heating & Lighting Company showed the details of various heating and pressure systems, including hot water, vapor and electric systems.

The Goff Electro Pneumatic Brake attracted much attention. Its simplicity is remarkable, abolishing as it does the use of the triple valve, brake valve, retaining valve, car train signal pipe and other appliances. This system is just being developed, and was described and illustrated in our July issue.

The Goldschmidt Thermit Company showed the complete appliances that have worked such economical changes in locomotive frame welding and other heavy parts.

The Gould Coupler Company had an extensive exhibit of various types of draft gears, vestibules, platforms and buffers, including friction buffers, trapdoor rigging and other improved devices.

The Grip Nut Company showed their latest devices both in construction and testing, both of which features seem to have reached perfection.

H. G. Hammett's locomotive bell ringer and other devices were in silent and simple operation, all elegant in finish.

The Hunt-Spiller Manufacturing Corporation had an extensive exhibit of their justly celebrated packing rings and other attachments which attracted marked attention.

Jacobs-Shupert U. S. Firebox Company showed a firebox built up of a series of units making it possible to replace a single unit without the need of rebuilding the entire firebox. Over 1,000 less staybolts than in other types may be used in this type of boiler.

The Locomotive Pulverized Fuel Company's exhibit attracted wide attention and was the subject of much favorable comment among the leading railway men, the general opinion being that pulverized fuel will soon be in general use on locomotives.

The Locomotive Superheater Company showed an extensive variety of designs of the details of superheating appliances. Marked improvements were shown in the forms of fire bricks as well as quality in the material. The smaller-sized bricks seem to meet with popular favor.

The Mahr Manufacturing Company had a complete set of oil burning tire heaters at work which heat any size of tire in eight minutes with the cheapest grade of oil. The housing is adjustable for all size wheels and can be rapidly put on or off.

Manning, Maxwell & Moore, as usual, had a fine exhibit both in complete machines and parts and all of the best in mechanical detail and construction.

McConway & Torley showed the latest development of the M. C. B. coupler, a modification of the most popular form of coupler. Uncoupling rods operating from one or both sides of the car and from the platform, or with underneath uncoupling rods were all in action, all simple in design and substantial in construction.

McCord & Company exhibited the McCord steel box and other appliances showing greatly increased strength to meet the growing requirements of railroad service, and diminution in weight made possible by the use of the very best materials.

The Nathan Manufacturing Company had a fine display of highly finished products superbly arranged. The "Delco" Safety water gauge is one of their latest devices coming rapidly into favor. The gauge has the particular merit of being readily seen from any part of the cab. The absolute protection is insured by the insertion of wire around the glass.

The National Malleable Castings Company had on exhibition complete outfits of car door fittings, safety fasteners, bracket handles, stops, hangers and other appliances, all having stood the test of time and admirably adapted to their purposes.

The National Tube Company is now a national institution, and the exhibition of its fine products was worthy of the company's reputation. The "National" pipe is now everywhere in industries of every type. The Spellerizing process greatly lessening the tendency to corrosion is a unique characteristic that ensures its durability.

The New York Air Brake Company had a very complete outfit of air brake equipment and clever demonstrations showing all of the features of their various devices.

The O'Malley Beare Valve Company

had a collection of valves adapted to every kind of service, including many new designs showing fine ingenuity and high-class workmanship.

The Pilliod Company had fine valve gear models in operation which attracted much attention, and a staff of demonstrators thoroughly skilled in the intricacies of valve gear. The gear is rapidly becoming standard on many of the leading railroads.

The Pyle National Company had an extensive display of turbo-generators, headlights, lamp stands, and other products. The electric turbo-generators were particularly interesting.

The Q. & C. Company's Bonzano rail joints was much in evidence. There are millions now in use on many railroad systems and it is growing in favor wherever it is in use.

The Robinson Company showed an exhaust nozzle, furnishing a soft exhaust with reduction of sparks and a continuous low vacuum with a steady stream from the avoiding intermittent blasts and saving fuel.

The Safety Car Heating & Lighting Company showed the safety electric light, the Pintsch mantle light, and other appliances and attachments in new and improved forms.

William Sellers & Company had a fine exhibit of machine and locomotive appliances, among which were samples of the perfected locomotive boiler tester. A special boiler filler which can be also used for washing boilers and also a fire extinguisher was shown, and other valuable new devices.

The Southern Locomotive Valve Gear Company had a model locomotive finely finished and the valve gear in running order that attracted much popular attention.

The Watson-Stillman Company's hydraulic machinery, including rail benders, shears and riveters, pumps and presses, jacks, valves and fittings, made an excellent display.

Westinghouse Air Brake Company had a great display, and ably sustained the company's reputation as the greatest of train safety devices.

The Westinghouse Electric & Manufacturing Company had a remarkable exhibit of their various equipments, including the single-phase multiple-unit equipment which has revolutionized rapid transit in many congested localities.

The White-American Locomotive Sander Company showed the perfected Graham-White locomotive sander in operation and the cleaning blast showed how the sand pipes can be instantly cleaned both above and below the trap. It is the perfect self-cleaning appliance for sand pipes.

# Annual Convention of the American Railway Master Mechanics' Association

The forty-ninth annual convention of the American Railway Master Mechanics' Association was held at Atlantic City, N. J., beginning on Monday, June 19, and continuing the following two days. President E. W. Pratt presided, and in the course of an able opening address alluded to the abiding supremacy of the steam locomotive as the one self-contained power plant that will meet the demands of service and economy, in this land of great distances and low unit costs of transportation. This will endure for many years to come, and hence it is essential that it should be carefully studied, improved and perfected to hold its well deserved prestige. The increase in the number of locomotive appliances and increase in power were pointedly alluded to, and coincident with these advantages was a lessening of the weight of many of the moving parts, amounting to as much as 7,000 pounds. The use of powdered fuel was alluded to in the most assuring manner and the advantages briefly summarized as leading to cinderless, sparkless and smokeless operation, as well as a saving in fuel and labor not only to the firemen but at the ashpit. The improvement in the older types of locomotives by the application of the most modern improvements was also pointed out. The importance of shop lay-outs was also touched upon and the need of a committee on this subject was suggested. The need of a closer co-operation with the universities where experiments and tests can be more successfully accomplished than in the hands of railway men already engrossed with the details of daily work was also recommended, as well as a closer association with all of the other associations connected with the details of railroad operations whereby they would become valuable adjuncts of the Master Mechanics' Association, and time and attention should be given to them so that they would ultimately become the "steering committee" of the association's work to the mutual advantage of all concerned. A better system of training was strongly advocated to the end that promotion might be more intelligently and wisely made, and though much had been done there was still much to do in this direction. In closing the president paid a well deserved compliment to the work of the mechanical department of railways generally. It had been done with limited appliances in a time of greatly increased traffic amounting sometimes almost to congestion, but the situation had been met admirably, showing that an efficient organization existed all along the line. Hopes were expressed that this high standard of efficiency would continue, and

the full appreciation of the great work in which they were engaged would come in due time.

#### GENERAL BUSINESS.

Secretary Taylor reported that the membership numbered 907 active members, 96 representative members, 20 associate members and 44 honorary members. The receipts during the year amounted to \$11,192.40 and the expenses \$11,123.00, leaving a balance of \$69.60.

Dr. Angus Sinclair, treasurer, reported cash on hand, \$1,560.08. The reports were referred to the Auditing Committee, consisting of H. C. Manchester, G. M. Basford and G. E. Parks, who latterly reported that the accounts were correct.

The recommendation of the Executive Committee that the dues of active and as-

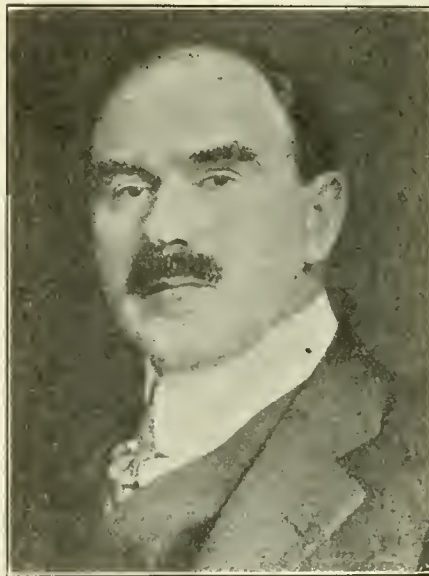

E. W. PRATT,

President of the American Railway Master Mechanics' Association, 1915-16.

sociate members be fixed at \$5 per year, and representative members at \$7 per year per 100 locomotives was adopted.

An amendment to the constitution regarding the election of officers was adopted, providing that the election be by ballot during one of the regular technical sessions.

Special committees reported in accordance with the subjects submitted to their consideration. All showed how carefully the subjects had been considered, and a mass of valuable data had been collected. Many of the reports called out interesting experiences, but as in the meetings of the Car Builders' Association the committee's reports met with general approval. The following are condensed reports of the most noteworthy:

#### Mechanical Stokers.

The Committee on the above subject reported briefly that it was not expedient to get exact figures in regard to the comparative tests of the various stokers in their present transitory stages, seeing that so many of the improvements now under way materially alter their standing for accurate comparative purposes. The Street, Hanna, Standard and Crawford are the leading types, and these are undergoing changes looking towards higher efficiency. The first three belong to the scatter or overhead group, while the Crawford is of the underfeed type. Although all are doing excellent work, it is safe to assert that the full development of the mechanical stoker has not yet been reached. On April 1, 1916, there were of the Street type of stoker 866 in use, with 152 orders on hand, Crawford 413, with 63 orders, Hanna, 39 with 39 orders, Standard 100, with 125 orders, making a total of 1418 stokers in service, and 379 orders. Other machines are in service but the report in regard to them is not added to since last year. The Committee were of opinion that the mechanical stoker is no longer an experiment, but a device of great and growing importance. The Street Company has recently designed and constructed two machines known as their Duplex, one of which has been applied to a Mallet engine on the Norfolk & Western, and the other to a locomotive of a similar type on the Chesapeake & Ohio railway.

The Committee comprised A. Kearney, chairman, M. A. Kinney, J. R. Gould, J. T. Carroll, J. W. Cyr, A. J. Fries and L. B. Jones.

#### Fuel Economy and Smoke Prevention.

Last year a pamphlet was published on "Fuel Economy on Locomotives" which covered the fundamentals of all instruction methods, but much of the advantage that should arise from rules will be lost if they are simply memorized. The Committee pointed this out very clearly and emphasized the fact that road supervision must point out the results of improper methods, and the advantages from an observance of the rules. The inexperienced fireman must learn through his observation. The true instructor must be capable of placing himself in the position of the learner,—must appreciate his difficulties and possess the ability to approach his task as though he were himself a novice.

Moving pictures also may be made to indicate the correct methods of preparing fires, firing engines, and the results of improper practices in these particulars.

Pictures of engines in operation, showing the influence of proper and improper firing upon the smoke emitted, may also be made extremely instructive. In regard to railroad literature every road foreman should be required to read at least one periodical monthly, dealing with railroad matters, and attention should be drawn to articles of unusual value. Single marked copies should also be occasionally liberally distributed.

The Committee comprised Wm. Schlawge, W. H. Flynn, D. M. Perinc, Robert Quayle, F. H. Clark, D. J. Redding, and W. J. Tollerton.

**The Best Designs and Materials for Pistons, Valves, Rings and Bushings.**

Reports from 34 railroads make no distinction between saturated and superheated locomotives on the design of pis-

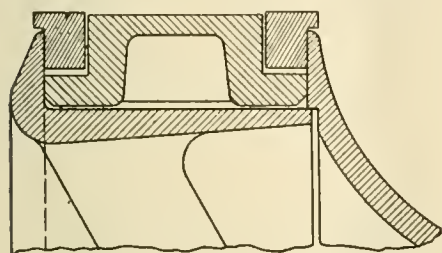

FIG. 1. PISTON VALVE-L-RING.

tons, valves, rings and bushings, on locomotives equipped with piston valves. Many railroads are using Hunt-Spiller gun iron for these appliances, while a smaller number use ordinary cast iron for the purpose; a number of roads use Hunt-Spiller iron for superheater locomotives and ordinary cast iron for saturated locomotives. Sixteen roads use a

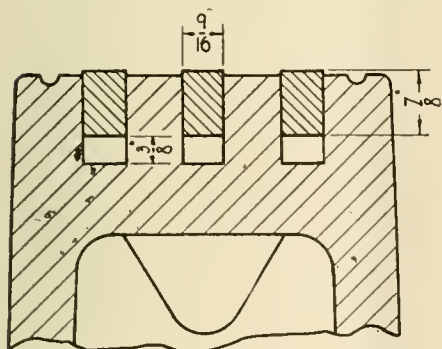

FIG. 2. PISTON PACKING RING.

fillet in all corners of ports in piston valve bushings, and 15 roads provide no fillets, or fillets only on the exhaust edge of the steam port. The Committee, recommended the use of a fillet in all corners of piston valve bushing ports with a 1/2 in. radius as the standard. The arrangement of piston valve bull ring and packing rings in most common use is shown in Fig. 1.

In regard to piston packing rings on superheater locomotives on 34 roads reported from, 28 were using Hunt-Spiller

iron and 6 cast iron. The limited data at hand was such that at the present time no recommendation was made as to the advantage of either, but sketches were furnished of some designs of rings of which Fig. 2 seemed to be among the most popular.

The Committee included Jos. Chidley, chairman, H. T. Bentley, C. F. Giles, A. K. Gallaway, L. A. Richardson, G. W. Rink, and W. D. Robb.

**Design and Maintenance of Locomotive Boilers.**

From thirty one roads the Committee received replies to inquiries in regard to improvements on the above subject, and many new devices were submitted including a fire-box composed of sectional U-shaped plates, with similar wrapper-sheet construction, riveted together, which eliminates stay bolts; another fire-box which consists of squared water tubes, expanded into water and steam drums at the top and a water leg at the bottom, eliminating stay bolts on the sides of fire-box; a corrugated fire-box also eliminating nearly all of the stay bolts; also several types of water-tube locomotive boilers; besides devices to improve circulation, and various forms of combustion chambers and brick arches, and the almost universal adoption of superheaters. The combustion chamber seemed to meet with the most popular approval, on account of the longer flame travel and consequent shortening of flues. The use of long flues is not favored, for while the evaporation capacity is enlarged the rate per unit of heating surface is lowered. The addition of superheaters is practically unanimous. The welding of flues into flue sheets, of fire-box seams, and the application of patches and other repairs marks a radical improvement. Between the merits of electric and acetylene welding the Committee did not venture an opinion, both methods having their supporters. The Committee, however, were much impressed by the processes of autogenous welding for boiler maintenance.

The Committee consisted of C. E. Fuller, chairman, A. W. Gibbs, D. R. MacBain, M. K. Barnum, R. E. Smith, C. B. Young, and J. Snowden Bell.

**Superheater Locomotives.**

The Committee reported that at the beginning of the year there were in service in the United States and Canada 15,666 locomotives equipped with superheaters, practically all of the fire-tube type. Very few are equipped with slide valves. Nearly all are equipped with brick arches. The return tube, top header, double loop superheater is the type of superheater most generally used. An economy of fifteen to twenty-five per cent. in fuel, and twenty to thirty per cent. in water con-

sumption, and even greater economies have been shown. No changes in the front ends are necessary except such as are owing to the presence of superheater elements, header and damper. Two gauges of water, with full throttle and short cut-off, where operations permit, was recommended. The majority of railroads are using a superheat oil for the lubrication of superheater locomotives, stating that it does not carbonize. Vacuum relief valves are generally used, although there is some question as to what benefit, if any, results.

The Committee comprised W. J. Tollerton, chairman, H. W. Coddington, C. H. Hogan, R. W. Bell, T. Rooke, W. C. A. Henry, E. W. Pratt, and G. W. Basford.

**Design, Maintenance and Operation of Electric Rolling Stock.**

An interesting account of the development of the use of electricity in railroad transportation was presented by the Committee and the various designs were described from which it appeared that scarcely two orders for electric locomotives have been built from the same plans, showing that a variety of designs will likely continue to appear. Reports, however, showed that the designs without the use of gears or transmission rods are

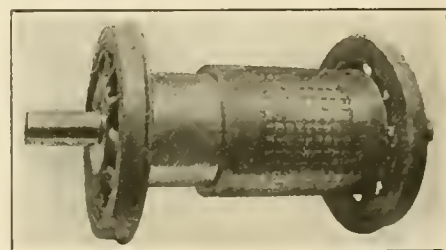

NEW YORK CENTRAL GEARLESS MOTOR.

the most efficient for train speeds exceeding 45 to 50 miles an hour. Below these speeds the gear and pinion are probably the most efficient. The use of a jack shaft has not been found entirely satisfactory, as it has been found difficult to keep it from pounding and running hot. When gears are used, some design of spring or flexible gear will be found desirable. Up to the present time there is no uniformity in the delay records of railroads. The records are confusing and misleading. A conference was held at Washington last January under the auspices of the Department of Commerce, and a uniform code will likely be adopted in the near future.

The Committee consisted of C. H. Quereau, chairman, G. C. Bishop, G. W. Wildin, J. H. Davis, R. D. Hawkins, T. W. Heintzelman, and A. E. Manchester,

**Equalization of Long Locomotives.**

The Committee on this subject presented an interesting report of a historical

kind running back to Peter Cooper's "Tom Thumb" up to the present time giving a detailed account of the progress of the use of equalizers and their important relation in the development of the modern locomotive. Briefly the report concluded that in all types of locomotives the equalization systems should be divided as nearly as possible to the center of gravity of the spring-borne parts, as, if this is not done, there is danger of engine truck not carrying its legitimate load, which may result in derailment.

The Committee was comprised of Wm. Elmer, chairman, S. M. Vauclain, E. J. Cole, O. C. Cronwell, J. F. Enright, C. H. Rae, and C. B. Young.

**Use of Powdered Fuel in Locomotives.**

The Committee reported that advancement had been made in the use of powdered fuel during the year, in other words some real progress had been made. A New York Central locomotive was the first locomotive equipped for burning powdered fuel, and it has been used chiefly for the development and improvement of the apparatus necessary for supplying powdered fuel to the fire box, and in drafting the locomotive. It is a ten-wheel superheater engine, and has been used in helper and in freight service. A Chicago & Northwestern locomotive of the Atlantic type equipped with superheater was also being experimented upon with powdered fuel appliances, and in a comparative test made with a duplicate engine burning coal on grates has thus far proven favorable to the powdered fuel, especially in saving fuel in firing up, movement at terminals, and dead time. With coal considerable loss was occasioned for work other than while pulling the train. The Delaware & Hudson Company has also just received from the builders a consolidated locomotive using powdered fuel, but the Committee could not present a comprehensive or conclusive report on the burning of pulverized fuel in locomotives, but a decided advance had been made and the future is full of promise.

The Committee were C. H. Hogan, chairman, E. W. Pratt, J. H. Manning, Chas. James, W. H. V. Rosing, Thos. Roope, and G. L. Fowler.

**Specifications and Tests of Materials.**

The Committee after recapitulating a large number of the recommendations made last year in regard to specifications and materials urged the necessity of the members insisting on a closer observance of the new Standard and Recommended Practice Specifications, and advised that they generally be used by the Association. It was only in this way that the Committee can make the greatest progress so far as improving and standardizing the

specifications and practices of the various members.

As an illustration of testing materials it may be of interest to state in testing steel tubes except superheater pipes, a test specimen not less than 4 in. in length shall have a flange turned over at right angles to the body of the tube, without showing cracks or flaws. This flange, as measured, from the outside of the tube shall be 3/8 in. wide for tubes 2 1/2 in. or

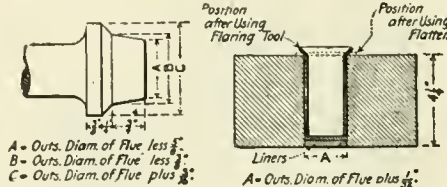

FLARING TOOL.

DIE BLOCK.

under in outside diameter, and 1/2 in. wide for tubes over 2 1/2 in. in outside diameter. In making the flange test, it was recommended that the flaring tool and die block shown above be used.

The Committee consisted of C. D. Young, chairman, H. E. Smith, L. S. Randolph, A. H. Fetters, H. B. McFarland, J. R. Onderdonk, N. E. Sprowl, and Frank Zeleny.

**Modernizing of Existing Locomotives.**

Thirty-two railroads furnished reports to the Committee mostly in answers to the question of changing the type of Consolidation locomotives, 2-8-0 into Mikado 2-8-2, the matter of weight and capacity being the vital issue. A large number of locomotives have thus been modernized. This change is especially desirable where greater boiler capacity is necessary in maintaining speed and sustained horse power. It is in the interest of economy that these changes have been made. A

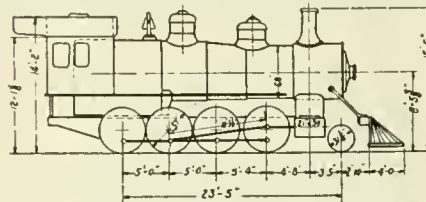

SANTA FE CONSOLIDATION LOCOMOTIVE WHICH MAY BE CHANGED TO MIKADO TYPE.

Mikado engine can at times be operated at much longer cut-off without lowering the steam pressure too much, the boiler being ample to provide sufficient steam under the most exacting conditions. Generally speaking a locomotive boiler cannot be made too large. It is often made too small. Therefore it increases economy to increase the boiler capacity. The change justifies the cost, as long as it is sure to pay for itself in a reasonable time. A large grate area within limits of freight is better than burning coal at a high

rate of combustion on a small grate. In enlarging the boiler in changing from Consolidation to Mikado it is more satisfactory in increasing the size of the fire-box and grate than merely lengthening out the barrel and flues. The application of superheater and brick arches are also important items in the modernizing of the olden types of locomotives.

The Committee embraced E. J. Cole, chairman, J. C. Little, C. A. Gill, M. J. Drury, R. D. Hawkins, J. Snowden Bell, and D. J. Mullen.

**Train Resistance and Tonnage Rating.**

Two years ago the Committee on this subject presented a report containing all the data that was available at that time. The report was referred back, and much additional data has been obtained, but obviously the most accurate and the most satisfactory method to determine the tractive effort of a particular class of locomotives is to measure it under severe conditions by means of a dynamometer car, operated with different locomotives

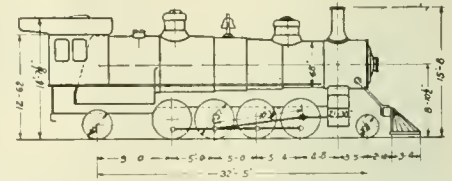

MIKADO LOCOMOTIVE WHICH MAY BE MADE BY REBUILDING CONSOLIDATION TYPE.

of the same class. An average of values may then be arrived at. Few roads, however, own dynamometer cars, and it is necessary to use other means in calculating the tractive effort of a locomotive. The most authoritative and most complete formulae are to be found in "Locomotive Data," published by the Baldwin Locomotive Works. Over twenty pages of descriptive matter and tables in this valuable work cover almost every conceivable combination, and is a safe guide on this subject. While the Committee endorsed this publication, it did not feel that it was within the province of the report to set forth any definite rules covering the subject.

The Committee consisted of O. C. Wright, W. E. Dunham, H. C. Manchester, C. E. Chambers, J. H. Manning, Frank Zeleny, and Prof. E. C. Schmidt.

**Election of Officers**

In what may now be regarded as "ancient times" there was considerable electioneering in the choice of officers for the American Railway Master Mechanics Association, but for several years the practice has been adopted of advancing the officers from the standing list and there has been no disposition manifested



of departing from that rule. The president is elected for one year only and the remaining officers are advanced in rotation. At the last convention the following officers were elected.

President, William Schlafge, general mechanical superintendent Erie Railroad; First Vice President, F. H. Clark, general superintendent, Baltimore & Ohio Railroad; Second Vice President, W. J. Tollerton, general mechanical superintendent, Chicago, Rock Island & Pacific Ry.; Third Vice President, C. F. Giles, superintendent of machinery, Louisville & Nashville Railroad; Treasurer, Angus Sinclair, Angus Sinclair Company, New York.

Executive Members: John Purcell, assistant to president, A., T. & S. F. Ry.; M. K. Barnum, S. M. P., Baltimore & Ohio Railroad, and W. E. Dunham, C. & N. W. M. A. Kinney, H. V., was elected to serve during the unexpired term of J. F. De Voy.

J. W. Dow was elected a life member.

#### Other Exhibits Worthy of Special Mention.

Among other new devices worthy of special mention were that of the Cutler-Hammer Manufacturing Company, with numerous safety devices; the Davis Machine Tool Company, whose marked improvements in lathes was the theme of much favorable comment; the Milburn Oxy-Acetylene welding and cutting apparatus, showing their latest improvements at work; the Consolidated Railway Electric Lighting & Equipment Company with complete apparatus of "axle light" equipment in place on a car truck; the Mudge-Staten removable box front end, and the Mudge-Peerless car ventilators for steam railways, both improvements of real merit; the Draper Manufacturing Company's pneumatic flue welders for scarfing, welding and swedging boiler tubes of all sizes, and a new flue reclaiming attachment for welding long ends on flues; the Peacock geared hand brake for baggage, express, and all kinds of "blind end" cars; the Flower Brush Holders adapted for attaching the brush without removing base; the Ellsworth Harding steel specialties adapted to every kind of tool; the Brown power reverse gear manufactured by the Southern Locomotive Valve Gear Company whereby the entire movement of gear is controlled by reverse lever which is simplicity itself; the Mitchell metallic packing, which has many friends; the Phoenix and Conradson turret attachment for engine lathes, which are marked improvements on lathes; and the Snyder reverse gear manufactured by the Pittsburgh Locomotive Power Reverse Gear Company, which is fool-proof.

## New Style of Decoration in Dining Cars

The passenger department of the Burlington Route, anxious to keep pace with the everlasting demand for something new in the added comforts of railroad travel, has introduced a new type of dining car, possessing not only the comforts of home, but also the appearance of the best types of home. Although an innovation especially in decorative schemes for dining cars and absolutely unlike any other car in use anywhere, the enterprising company has introduced it merely as an experiment. Owing to the all-steel construction and the conditions of service, ordinary finishings do not long remain as satisfactory in point of elegance as suits

more sanitary, and also gives patrons who are taking long trips the unusual experience of being able to walk into an entirely different kind of a dining-room-on-wheels. Before any great number of these cars are built, however, the company is taking pains to secure the opinions of the patrons where views and suggestions will be carefully noted. To this end circulars are distributed among the patrons calling for opinions on the innovation. It may be added that the opinions so far are highly commendatory, but time is the great test of all mundane things, and the company will not likely be in any great hurry launching forth



NEW TYPE OF DINING ROOM ON THE BURLINGTON ROUTE.

the fastidious eye. A checkerboard of cracks soon appear on the varnished steel. These are inseparable from the extremely varying climatic conditions peculiar in some regions, and particularly so in the Northwest. The experts of the Burlington have called wall paper into the service, and this prepared by a special process, and then finely varnished shines forth in burnished beauty and bids the elements defiance.

Fifty or more different patterns and varieties will soon be available for the interior decorations on the Burlington Route. It embodies a very desirable and unusual feature—that of being more home-like and inviting, and is claimed to be

into extensive changes in construction and decorative schemes until the call approaches unanimity. Meanwhile passengers leaving the Union Station, Chicago, at 6:30 p. m. every day on the Burlington's Minnesota Limited for St. Paul, Minneapolis, if they do not immediately pass into slumberland, which is quite pardonable in the elegant luxuriousness of the palatial cars, they should cast their critical eye on the exterior decorations of the new dining car, and after silently expressing their gratitude that they are not in the trenches in France, give expression to their opinion in writing in regard to the artistic attempt of the Burlington to make them feel at home.

## Department of Questions and Answers

### Smoke Washing.

J. M. Portchester, N. Y. asks:—How is smoke washing performed, and what means are used to force the smoke into or through the water? A. The appliances generally in use consist of three large concrete basins, a large wooden stack, a steel fan six or seven feet in diameter, driven by a motor. A circular conduit, five feet in diameter made of what is known as transite material, extends around that portion of the engine house usually occupied by smoke jacks. This conduit is immediately below the roof. There is a telescope jack, extending down from the under side of the conduit to each pit having a funnel on the lower end that may be pulled down on top of the locomotive stack. This smoke jack is so constructed that it may be moved some distance to suit the exact position of the locomotive. A damper is attached to close the jack when it is not required. At the center of the engine house the conduit branches out and makes a connection with the fan referred to. Three wooden ducts branch out from the fan, each leading to one of the water compartments. Directly above the outlet of each one of these three branches is a hood similar to a bell with a closed top. The fan draws the gases from the locomotive through the telescope jacks, and through the conduit, forcing the gases into the water tanks which are partly filled with water. There is also a steam jet in each one of the outlets which aids in heating and agitating the water. The gases are first forced into the closed bell referred to, and pass down through the water, and by means of a series of baffles, are thoroughly washed and sprayed with water, the gases disappearing through the stack in the whiteness of exhausted steam. The solids and carbons appearing on the surface of the cars in the large vats in the form of foam. This is skimmed off and dried, having the appearance of lamp black. With approximately eighty locomotives from eight to ten barrels of this material are collected every day. The acids in the gases are very destructive of metals. The fan is also useful in maintaining the fire without using the blower. In some engine houses the material collected is said to pay for the expense of fuel and water used in the appliance.

### Cross Compound Compressor Trouble.

H. W., Wilmington, Del., writes: I have studied the articles on repairs to cross compound air compressors made in a recent issue, and would like to ask you several questions on the subject: (1) What will cause a quick down stroke of the low pressure air piston and a quick up-stroke of the high-pressure piston? (2)

What causes the slow up stroke of the low pressure air piston and at the same time a very slow down stroke of the high-pressure piston? (3) What could be wrong when the compressor works with a very slow up stroke of the low pressure piston and a fast down stroke when there is no air drawn into the low pressure cylinder on the down stroke and nothing can be found wrong with the upper intermediate air valves? (4) Why is it that an excessive quantity of oil admitted to the cylinder sometimes gives a temporary relief? A.—(1) This usually is caused by leaky upper intermediate air valves, valve seats or a leaky gasket between the high and low pressure air cylinders, although it may be caused by other disorders that will be mentioned in answer to your other questions. (2) This is the natural result of the fast down stroke on the previous movement, as the upper side of the low pressure air piston may have a considerable air pressure at the start of the stroke as result of the leaky upper intermediate valves or gaskets. (3) This is generally caused by loose piston rings in the low pressure air cylinder. Assuming that the air valves all have a good bearing and there is no back leakage through any of the parts mentioned, the action of the loose rings is, when the cylinder is about one-half lubricated, to set away from the wall of the cylinder at the dry part. This allows compressed air to get between the ring and the wall of the cylinder on one stroke and instead of compressing the air in the cylinder it passes the rings into the other end of the cylinder, hence the quick stroke in one direction. A slow movement may also be caused by leaky packing rings in the high pressure air cylinder. Thus when the high pressure piston nears the end of its stroke the air pressure passing the rings increases the pressure in the end of the cylinder that is being filled from the low pressure cylinder and when this pressure increases somewhat above 40 pounds, the tendency is for the low pressure piston to stop, hence the slow movement. (4) The reason a large quantity of oil temporarily overcomes the trouble from loose or worn out packing rings is that as soon as the cylinder is lubricated freely all the way around there is no more chance for the compressed air to get between the outside of the rings and the wall of the cylinder until a portion of the cylinder again becomes dry. When the compressor gets into a condition of this kind it should be removed for the renewal of rings or truing up of the cylinder if necessary. When washing out the cylinder with lye only gives temporary relief, the compressor should be removed so that proper repairs can be made. A pretty safe rule to follow is to know first that all of the

air valves, intermediate and discharge, are in good condition and any heavier repairs must be made in the shop. The article you mention explains why accurate repair work is essential on cross compound compressors. There are also certain defects of the steam portion that cause the slowing up of the pistons at certain points in their strokes, but this can usually be determined by listening to the exhaust, and if the steam end is at fault, the slow movement is generally accompanied by a very heavy blow through the exhaust pipe.

### Pressure in Brake Cylinders.

A. A. L., Malden, Wash., writes: (a) If we are carrying 90 lbs. brake pressure and move the brake valve to release position and obtain 110 lbs. in freight service and make a service application of 20 lbs., will it result in a greater brake cylinder pressure per square inch than if 90 lbs. pressure remained in the brake pipe at the start of the application? (b) About how much pressure would remain in the brake cylinders if brake pipe pressure leaked down from 110 to 20 lbs. in 25 minutes time? (c) Would the brake cylinder pressure be greater at the end of 25 minutes' time than it would be if the original pressure was 90 lbs. instead of 110? (d) Would there be any particular advantage derived from using 110 lbs. in the brake pipe on freight cars instead of 90 lbs.? A.—(a) No; the same number of cubic inches of free air enters the brake cylinder in either case. (b) Assuming that the application was started with a 20-lb. reduction, this will depend entirely upon the amount of leakage from the brake cylinders to the atmosphere and back leakage from the cylinders through the triple valve cylinder check valve and from the auxiliary reservoir (and consequently the brake cylinder at such times) into the brake pipe past the triple valve piston packing ring and the cylinder cap gaskets. If everything was absolutely tight about the brake equipment such an application from 110 lbs. brake pipe and auxiliary reservoir pressure would result in from 75 to 80 lbs. brake cylinder pressure, assuming that the piston travel of the brake cylinder is about 8 inches, thus the pressure at the end of 25 minutes' time will depend entirely upon the amount of leakage, and there are very few brake equipments, if any, in service that would retain more than 20 lbs. in the brake cylinder under the conditions you mention at the end of 25 minutes' time. If the drop in pressure was to be entirely due to leakage requiring 25 minutes to lower the pressure to 20 lbs. a brake application would not occur, as pressures would reduce equally and result in no movement of the triple valves. (c) The pressures due to leakage could be

expected to be somewhere near the same figure as given above, but from a 90-lb. brake pipe pressure a tight brake cylinder or a brake system free from leakage with 8 inches piston travel would accumulate about 65 lbs. pressure in the brake cylinder as a maximum and be subject thereafter to the same results from leakage that would be encountered with 110 lbs. brake pipe pressure. You will understand that the 20-lb. brake pipe reduction from either 110 or 90 lbs. would result in about 50 lbs. brake cylinder pressure, and if thereafter the leakage was at no greater rate than you mention there might be no further movement of the triple valve, and brake cylinder pressure would reach no higher figure, or there might be a movement during which the auxiliary reservoir and brake pipe pressure would reduce equally, but in which brake cylinder pressure could not increase as a result of leakage. (d) The advantage, if any, would be offset by other conditions; 110 lbs in the auxiliary reservoir in freight service would increase the volume of free air in the reservoir and provide a greater margin of safety in grade operation, but if all cars were not heavily loaded it would produce wheel sliding and likely other troubles; hence, 90 lbs. brake pipe pressure is the maximum recommended for freight service. Where the requirements of service exceed the capacity of the standard freight brake operated with 90 lbs. brake pipe pressure, the needed improvement should be met with an adequate brake system rather than by means of an increase in pressure. Such equipments known as the "Empty and Load" brake have been perfected and are in service.

#### Brake Sticking.

J. T., Baltimore, Md., writes: I had an 8-car passenger train and after an application one brake on the sixth car failed to release; the triple valve was tested and found to pass all tests on the rack, and the verdict was that I was responsible on account of having made too light a brake pipe reduction. Will you please explain to me how a good triple valve will fail to release after a light brake pipe reduction?

A.—Provided that you have not overcharged the brake pipe and auxiliary reservoirs and have a brake pipe feed valve in first class condition, you cannot make a brake pipe reduction that will apply all of the brakes and still be so light as to prevent the release of any one of eight perfect triple valves. The reason that the light reduction causes stuck brakes is that triple valves will get into such a condition that they will fail to release after a very light brake pipe reduction, but will release after a 10 or 12-lb. brake reduction, as in the latter case there is a greater difference between the pressure in the brake pipe and auxiliary reser-

voirs and the adjustment of the feed valve, and the capacity of the feed valve varies with any difference in the pressure it is working against. You should have called your accuser's attention to the fact that a triple valve test in the shops at this time of the year gives but very little indication of the actual performance of the valve when on the car in service and that, inasmuch as your brake valve manipulation was accurate enough to release all of the triple valves to the rear and in front of this particular one, it is quite likely that this one would also have released if it had been in as good condition as the rest at the time the trouble was experienced.

#### Leak at Brake Valve Exhaust Port.

J. M. B., Columbus, O., writes: What causes a leak from the train line exhaust port of the 11-6 automatic brake valve when the brake valve handle is on lap position?

A.—It is caused either by a leak from the equalizing reservoir pressure to the atmosphere or from a leak into the brake pipe. The difference can usually be told by observing the brake pipe and equalizing reservoir gage hands. If the equalizing reservoir gage hand falls it indicates leakage from the equalizing reservoir to the atmosphere but if the gage hands remain stationary it points to leakage into the brake pipe. These leaks may occur at any of the following points. A leak out of the equalizing reservoir may be  
In the equalizing reservoir,  
In the equalizing reservoir pipe,  
In the equalizing reservoir gage pipe,  
A leak in the tubes of the air gauge,  
A leak on the seat of the rotary valve,  
Leaking equalizing reservoir pressure to the atmosphere;  
Leakage from the brake valve body gasket.

A leak from the equalizing reservoir pressure through a flaw in the brake valve casting, the latter usually found between the equalizing reservoir and release pipe port.

The leaks into the brake pipe that may be found at different times, are:  
From the rotary valve seat of the automatic brake valve,  
Through the brake valve body gaskets,  
Through a flaw in the brake valve body,  
Through the distributing valve body gasket,  
Through a flaw in the distributing valve, or if the blow occurs only after brake-pipe pressure is lowered below the pressure in the brake cylinders,  
Through the equalizing cylinder cap gasket, or, if the valve has a quick action cylinder cap  
Through or past the seat of the brake cylinder check valve.

In addition to this, if the brake valve

cutout cock is located in the reservoir pipe, the leak may be through the cutout cock, and with some systems of air operated water scoops, the leak into the brake pipe may be back through the check valve from the water scoop reservoir.

#### Wrongly Connected Air Pipes.

J. T., Baltimore, Md., writes: On an engine just out of the shop, with a new distributing valve and two overhauled brake valves, it was found that there was a constant blow from the emergency exhaust port of the automatic brake valve and both brake valves were taken apart and examined and also the distributing valve and nothing was found wrong. The blow at the exhaust port still continued and the engine was taken back to the shop and I did not find out what was wrong. Could you tell me what could cause this blow?

A.—It is quite likely that some of the small copper pipes were wrongly connected, and this is the first thing that should be looked for when there is any unusual action of the brake on an engine just out of the shop. Under such a condition it will usually be found that the reducing valve pipe is connected to the independent brake valve where the release pipe should be and in one case of this kind we can recall where the equalizing reservoir pipe was connected to the application cylinder passage of the distributing valve and the equalizing reservoir to the independent brake valve, either one of which will cause the blow at the emergency exhaust of the automatic brake valve.

#### Reboring Air Pump Bushings.

W. H. B., St. Louis, Mo., writes: Is there any device on the market for reboring a main valve bushing of an air pump without removing it from the head, and is it a labor saving device?

A.—We know there are devices of this kind on the market or can be made, and in the March, 1915, issue, page 78, a device for boring the main valve bushing without removing it from the head was partially illustrated with a description, but it is a question whether such tools are always a labor saving or economical installation for the reason that the average main valve bushing can be knocked out of the head with a maul in about two minutes' time and a good lathe hand can re bore three or four of them while one of these devices is being set up and the job started.

#### Babbitt Metal.

Perhaps the most common alloy producing what is known as babbitt metal consists of 24 pounds of lead, 2 pounds of tin, and 2 pounds of antimony.

# Railway Engineering

A Practical Journal of Motive Power, Rolling Stock and Appliances.

Published Monthly by

**ANGUS SINCLAIR CO.**

114 Liberty St., New York.

Telephone, 746 Rector.

Cable Address, "Locong," N. Y.  
Glasgow, "Looauto."

**Business Department:**

ANGUS SINCLAIR, D. E., Pres. and Treas.  
JAMES KENNEDY, Vice-Pres.  
HARRY A. KENNEY, Secy. and Gen. Mgr.

**Editorial Department:**

ANGUS SINCLAIR, D. E., Editor.  
JAMES KENNEDY, Managing Editor.  
GEO. W. KIEHM, Associate Editor.

**London Representative:**

THE LOCOMOTIVE PUBLISHING CO., Ltd.,  
8 Amen Corner, Paternoster Row, London, E. C.

**Glasgow Representative:**

A. F. SINCLAIR, 15 Manor Road, Bellahouston,  
Glasgow.

**SUBSCRIPTION PRICE**

\$2.00 per year, \$1.00 for six months, postage paid in the United States, Canada and Mexico. For other parts of the world, \$2.50, or ten shillings. Single copies, 20 cents. Remit by Express Money Order, Draft, Post Office Order or Registered Letter.

Mailing address can be changed as often as necessary—always give old and new address, and if you subscribe in a club, state the name of the agent.

Please give prompt notice when your paper fails to reach you regularly.

Entered at the Post Office, New York, as Second-class Mail Matter.

**Interchangeability.**

In speaking about automatic stokers at last Railway Master Mechanics' Convention, Mr. C. F. Street intimated that his company had a large number of stokers ready for assembling, all of them made with the parts strictly interchangeable. A movement of this character is thoroughly worthy of commendation for nothing will help more to keep down the cost of rolling stock repairs and maintenance than having as many parts as possible made interchangeable.

We have been hearing a great deal of late years about building rolling stock parts to exact gauges and templates, but the practice falls far short of the sentiment in favor of interchangeability.

Locomotive and car builders understand the advantages of having parts made to uniform sizes and their products bear the marks of this sensible sentiment, but when a locomotive or car reaches the home shop for overhauling the interchangeable conditions disappear. Shop foremen, as a rule, care very little for maintaining uniformity of parts and they cannot be expected to labor zealously for that line of work when they are not provided with the necessary gauges or templates.

We do not believe in standardizing everything, but we are impressed with the belief that car, tender and engine trucks could easily be kept standard and interchangeable. Where the will of the men in charge is favorable to uniformity, such parts as pistons, piston packing, valves, links, rod brasses and many other parts might be maintained interchangeable with much saving of operating expenses.

**Making Figures Lie.**

Unless it be among persons of an extraordinary skeptical turn of mind, the axiom that figures cannot lie is received as an infallible truth worthy to rank with demonstrated mathematical problems. Yet it is amazing to reflect how frequently the veracious figures that record the results of accurate mechanical experiments are made to parallel the audacity of Munchausen literature. In all departments of mechanical operations, devices are constantly being offered for application that are guaranteed to save all the way from five to fifty per cent, and when a test is made the inventor generally demonstrates that his claims can be made good.

Railroads are regarded as a particularly promising field for the operations of parties owning patented appliances designed to save money when saving seemed impossible. There is scarcely a railroad in this country where an inventor cannot succeed in proving that a saving of ten per cent will follow the adoption of any device he may have for sale, if he goes about the business in the proper manner. This is how so many trials have been made of patent valves, grate bars, spark arresters, smoke consumers and other attachments of locomotives; and how so little good has resulted from the use of appliances that promised important savings.

An inventor or his agent goes to a superintendent of motive power and talks up the merits of his device. Motive power officials are not generally zealous to try patented devices and the agent goes to a friend who has some influence with the management and secures an order to have the device tried entirely on its merits. It is placed upon an engine that has been pulling a certain train where there are good means for showing the amount of coal used before and after the test. Be-

fore the device was put on, the engineer and fireman worked away in an apathetic manner, neither wasteful nor careful about the manner in which the engine did its work. But when the new device was put on both of the enginemen are placed upon their best behavior, and naturally the engine is worked to the best advantage, so there is no difficulty about making an apparent saving of ten per cent or more. On one well known railroad system where a very careful record of the fuel consumed is kept, and which is required to try many new devices, it is well known that during the continuance of recorded tests a saving of from ten to twenty per cent of fuel will result. It makes little difference what the device may be. One month it may be a smoke preventer; another month it may be an improved lubricator. Both will have the same effect upon the coal pile; but the officers of the system know how the saving is produced, and what the result would be if the appliance were adopted as a permanent attachment to the locomotive. They do not harass the enginemen by demanding that the temporary savings should be made permanent.

All railroads are not so situated that the officers can tell just how the apparent but temporary savings are effected, and many appliances that have afterwards proved worthless have been forced upon the mechanical department through the species of experiments described. Sad experience has proved that all novel appliances offered to railroad companies should be thoroughly tested before they are adopted.

**Breakage of Piston Rods.**

One of the most common disorders that locomotives are subject to is the breakage of piston rods. A locomotive piston rod is subject to more severe service than any other part of railroad machinery. The alternate thrust and pull for each revolution of the driving wheels causes alternate tensile and compression stresses. The factor of safety proper for the material to resist either of these stresses is only half that required when it is subject to both. In addition to the matter of strength, the rod must possess sufficient rigidity as not to bend when subject to the load of the initial pressure on the piston head. The piston rod has also a wearing surface on nearly the whole of its length. For these reasons the piston rod is a vital portion of the engine and performs its functions under the most unfavorable conditions and the best material suited to these conditions should be used regardless of cost. The starting tensile and compression strength of steel is nearly twice that of wrought iron, and if these qualities only were to determine the size of a piston rod, we could make a steel rod half the diameter of an iron one. But when the diameter is less than

one-twelfth the length, the tendency to bend or buckle is greater than the tendency to stretch or crush. When the diameter is calculated for this, we find that a steel piston rod should be nine-tenths the diameter of an iron one. The strength and rigidity of steel being greater than iron and having greater hardness and uniformity, it will wear longer, so it is the best material.

#### The Nerve Straining Unforeseen.

We have frequently heard the question discussed, What is an engineer's principal duty while on the road? The answers to this question have been varied, but we think that most of our practical readers will agree with us that the first great duty of an engineer is to keep his eye riveted upon the track ahead, noting every signal and every sign that would have any influence upon the safety of the train. This is the duty that makes the fireman look-out keenly when not employed on the fuel duties, and induces him to keep an extra lantern lighted ready for any emergency. Get the train safely over the road is an engineer's principal duty, and makes him inspect his locomotive at every opportunity to see if any bolt or screw shows signs of weakness. This is the duty that calls for lunch pails as big as a bushel basket—there might be a snow blockade, a serious washout or a burned bridge. It is this uncertainty of what may turn up next—what the unforeseen may bring forth that makes an engineer's life the nerve straining existence few other occupations can equal.

#### Training of Firemen.

At a recent railroad convention we listened to a group of master mechanics and road foremen of engines ventilating their views on the training of engine-men, the vital question under discussion being, what shop experience ought a locomotive engineer to go through? The trend of opinion expressed was that railroad companies should employ a force of young men as shop helpers and that all new firemen should be drawn from this force. The new fireman should not be sent out at once to do regular fireman's work, but should be sent upon a trip at odd times so that he might become accustomed to the work by degrees. Someone remarked that his first experience as a fireman was on a big freight engine pulling a very heavy train on a dark stormy night, and that he had never forgotten the horror of the night and his gratitude towards the head brakeman who stood between him and utter failure.

The writer ran engines for years on a division where he was required to initiate novices into the art of firing. The teaching of this strenuous experience was that no particular qualities in a young man would insure his becoming a first class

fireman, but that no lazy man need apply. Laziness unfits men for all kinds of employment that demands skill and intelligence, but it is peculiarly fatal to a man required to keep a locomotive hot.

Taking into consideration the fact that a locomotive fireman is going through the training necessary to make him an efficient engineer we would put him to firing at once without any preliminary training. Then after he had gone through several years of road experience we would have him taken into the shop as a helper when he would be available to go out as an extra fireman. The shop experience on running repairs would be the best kind of training to fit the man for the position of locomotive engineer. Extra firemen going out on all kinds of engines, on all kinds of runs should be experienced men and they can be kept on the extra list in no other way.

#### Cost of Stopping Trains.

What does it cost to stop a train of 2,000 tons running at twenty-five miles an hour and work it back to the same speed? is a subject that has been discussed for years in engine houses, lodge rooms and other places ever since railway trains were run. The particulars are nearly as varied as the faces of the men engaged in the discussion. When the writer first heard that interesting problem discussed, it was on a passenger train weighing 150 tons running at 50 miles an hour on a level track. Then it was a freight train weighing 560 tons running 20 miles an hour.

It is difficult finding out the elements that enter into a problem of this sort, and different sorts of investigators or rather guessers vary much in their conclusions. The latest case of that kind appearing in print is recorded in the *Erie Railroad Magazine* which says that the expense of bringing a 2,000-ton freight train traveling at a rate of 20 miles an hour to a full stop and then regaining the original speed is 61 cents. That is lower than our investigations have found to be the case, but we should gladly give space to others who have investigated the question.

#### Our Encouraging Outlook.

We are hearing about hard times and interruptions to business due to the war in Europe, but the publishers of RAILWAY AND LOCOMOTIVE ENGINEERING have no complaint to make. In fact the year has opened with promises of prosperity that arise from increasing subscribers that has had no parallel in late years. The higher railroad officials such as presidents, general managers, superintendents of motive power and mechanical officials generally are displaying excellent examples in encouraging every person interested in railroad operation to subscribe for the paper.

#### An Injector Failure.

We recently ran across an old-time engineer who was busy abusing the right-hand injector and wishing for the good old days when reliable pumps were used on all locomotives. We know something about injectors and made a brief investigation which indicated that the throttle valve or steam valve attached to the injector leaked badly and on that account the instrument would not prime. By leaving it wide open and using the steam valve next to the boiler the injector worked fairly well.

Injectors have not yet got over being blamed for many mysterious disorders that are really the fault of throttles, primers, checks, and hose strainers. The blame for injector failures nearly always rests with the operator who has learned only part of his business.

#### A Throttle Valve Trouble.

On some roads where there are in use for years one certain kind of engine, the men become so used to the handling of them that another make, equally as good or better, is condemned as radically wrong on first trial. We remember one case where a new make of engine was condemned for slipping and the engineers complained till they got bigger sand-boxes put upon the engines. A thorough investigation made by a new foreman of engines proved that the throttle valve of the new engine was wide open by an inch movement of the lever, while the old ones opened about  $\frac{3}{8}$  inch by the same movement.

#### Value of Knowledge Added to Skill.

The work of railroad repair shops is extremely varied, and the greater portion can be done satisfactorily by men who possess no exalted order of mechanical ability or knowledge. But, on the other hand, special work arises which calls for the highest order of dexterity, besides unerring judgment and accurate knowledge of details. A tool gets out of order, whose anatomy is a mystery to ninety out of every one hundred machinists. Air pumps, hydraulic rams, pumps and jacks, steam hammers, pressure gauges, steam pumps, brake attachments, indicators, injectors and kindred articles are simple enough in their mechanism to those whose daily work it is to put the appliances together; but when such things get out of order hundreds of miles away from the makers and have to be repaired without delay, the man who proves himself competent to do the work is a valuable adjunct to a machine shop.

For the repairing of intricate machines and tools, essentials of machine shops, whose workings and mechanism are imperfectly understood even among good machinists, special knowledge and ac-

quired skill are requisite. An air pump comes in that is working indifferently, is intermittent in its action and seems to pound the cylinder head. A machinist, who can work as closely as a mathematical instrument maker, takes the pump apart and can perceive nothing wrong. The pistons are both apparently in good order, the valves seem to be faultless and the machinist can change nothing without the probability of doing more harm than good. Another man goes through the pump, and previous investigation and study of such machines give intelligent direction to his examination, and he quickly discovers that the trouble lies in the air valves having too much lift. Knowledge gave that man power. Knowledge and skill together have made him an expert in this particular line of work, and he is justly entitled to enhanced remuneration over the ordinary machinist, quite as much as the professional services of an accomplished oculist are fairly reckoned higher than those of an ordinary surgeon.

In railway repair shops there is a constantly growing demand for machinists capable of doing the intelligently skilful work that is becoming so plentiful about air brakes, injectors, gauges, hydraulic and electric apparatus with many other special machines whose construction is a mystery to the common workman. And there is likely to continue an increasing ratio between the demand and the supply until better means are taken to encourage machinists to acquire the special knowledge required in repairing complex appliances. So long as the super-skilled mechanic receives only the pay of the mediocre workman there will be little ambition manifested towards the higher lines of knowledge and skill.

#### Buying Books.

There is a growing tendency among artisans and business men to give books and book lore their due. This is a very desirable indication of progress, for only a few years ago men who used to help in their work information taken from books were looked upon with contempt by people noted only for their ignorance.

As people who are supposed to know the practical value of certain books we are frequently consulted about what books to buy and the result is sometimes very disappointing. This is not because the books bought are worthless, but because the purchasers expect too much from them. A little consideration should demonstrate to any one that when a book treats the manipulations and processes of some trade or calling, no matter how pretentious it may be in scope, it can cover only a few of the details involved. Those touched upon may be important, but the detail untouched will be so numerous by comparison that those treated will look insignificant.

Those who buy books treating of mechanical subjects should not expect impossibilities of the writers. Particularly they should not look for infallibility in the author, or expect not to find statements with which they probably correctly disagree. Buying such books with the idea that they the repositories of universal and all-sufficient knowledge will always be in the highest degree unsatisfactory. One item of information obtained from a book—information that may be of service a thousand times, may be worth several times the cost of the book and yet it may fail to supply much needed information.

#### Governmental Tyranny.

American publications have ventilated to some extent the scandalously unjust manner in which railway companies and other corporations are habitually treated by the United States Government, but it appears that other governments permit their Jacks in office to act as unjustly towards the people as do those in America.

In one of his recent articles to the *Glasgow Herald* our British representative, A. Fraser Sinclair, drawing on statistics collected by the Royal Automobile Club, writes: During the 12 months preceding the collection of the statistics, free of expense to the State, it is estimated that at least 12,500,000 miles were covered by those cars in the course of their running. The work performed included the conveyance of wounded soldiers at all hours to and from railway trains and hospitals, entertainments and pleasure drives; assisting the police in various directions; driving military officers in the performance of their duties, and assisting generally in any way the military authorities required. In driving wounded soldiers and sailors, cars, furnished free and voluntarily, carried 1,020,300 men to and from or between hospitals, the distance covered being 4,591,650 miles. That absolutely necessary work, performed free by motorists driving their own cars frequently, saved the country something like £114,790, while the duty paid on petrol by the car owners brought in revenue amounting to £7,650. That is to say, motor car owners doing the government work towards the wounded at their own expense had to pay £7,650 for the privilege of doing it. And the government, to show their high appreciation of the conduct of the motorists, intend to double or treble the motor car taxes.

#### THE HYPOTHEICAL MILLIONS LOST.

A useful service will have been performed by the Royal Automobile Club if the report on the alleged pleasure motoring knocks the bottom out of the outrageous statement by the National Organizing Committee for War Savings that if pleasure motoring were stopped millions of pounds would be saved. So far

from there being a saving to the country if the motor cars seen on the roads were prevented from using them, it has been demonstrated that there would be an immense loss. It is agreed that most of the cars now on the roads are there for one war use or another, and if the cars were not supplied free by motorists they would have to be provided at the expense of the country. The R. A. C. figures prove that some 100,000 motor cars owned by private motorists were employed in the year covered by the report in various kinds of war work at the expense of the owners. Let it be assumed that if instead of that number of privately owned cars being employed the government had been compelled to buy 30,000 cars to do the work and employ 30,000 men to drive them, the capital expenditure at £300 per car would have been £9,000,000, with an annual charge for interest of £450,000, while the wages of the drivers, assuming them to have been engaged at the beginning of the war, would sum up to £3,000,000 per annum. Instead of any saving of millions such as the National Committee have prophesied there would have been, had motoring been stopped, a very substantial addition to the already heavy burden of war debt and taxation. And these motorists, men who have given their money and time ungrudgingly to help the poor fellows wounded at the front, are described as friends of Germany, as in fact traitors, should they take a run into the country for a week end's spell of fresh air on the car which has been working for the wounded all the rest of the week.

#### Discontent with Present Work.

Many boys in machine shops lose their opportunities of becoming skilled mechanics, through waiting for a better job, just as some men die waiting for something to turn up. There is no job to begin to do good work on like the job on hand, and no mistake greater than supposing that the very best mechanical skill cannot be displayed on what would be called a very ordinary piece of work. Nothing is more common than to hear complaints from apprentices that they don't get an opportunity to learn the trade at which they are working, but, generally speaking, no one gets the opportunity; he makes it. There is no conspiracy to keep any one out of the position he ought to fill, but he must get into that position by his own exertions. If a boy demonstrates that he is capable of doing a simple job of work better than any one else, he is morally certain to get tried on a better one. If he fails to do the present job right because there is not scope enough for his ambition, he makes it appear that it would be unsafe to trust him with better work. There is no other sure road to advancement than through present duties well performed.

## Ten Mikado Type Locomotives for the Chicago Great Western Railroad

In 1912 the Baldwin Locomotive Works built ten Mikado type locomotives for the Chicago Great Western Railroad. These engines were equipped with superheaters, and proved highly successful in both slow speed and fast freight service. A test of one year's duration showed a fuel economy for the Mikados of 37 per cent. in coal consumed per ton mile, as compared with Consolidation type locomotives using saturated steam. The result of the test fully proved the superiority of the Mikado type for service on this line.

Ten new Mikado type locomotives as illustrated have recently been built for the Chicago Great Western by The Baldwin Locomotive Works. The design is based on that of 1912, but the details have been revised wherever improvements could be made. The tractive force exerted by these locomotives is 55,200 pounds, and

castings, 5 inches in width, with separate rear sections arranged for the Hodges type of truck. The equalization system divides between the second and third pairs of driving wheels. There is no cross equalization back of the rear drivers, as is usual in locomotives taking this type of truck. Owing to the location of the firebox, it is necessary to place yokes over the rear driving boxes; and the back equalizers are so shaped that they can be directly connected to the links suspended from these yokes. The Rush-ton patent main driving-box is used. This box is made in one piece extending across the engine, and has a brass fitted on each side. The spring saddles are arranged as usual, and are seated directly on the top of the box.

The tender is carried on rolled steel wheels, and the trucks are of the equal-

material, steel; thickness,  $5\frac{3}{8}$  in., No. 9 W. G.; 2 in., No. 11 W. G.; number,  $5\frac{3}{8}$  in., 36; 2 in., 262; length, 18 ft. 6 in.

Heating Surface.—Fire box, 260 sq. ft.; tubes, 3,459 sq. ft.; firebrick tubes, 40 sq. ft.; total, 3,759 sq. ft.; superheater, 798 sq. ft.; grate area, 70 sq. ft.

Driving Wheels—Diameter, outside, 63 in.; diameter, center, 56 in.; journals, main, 11 in. x 15 in.; journals, others, 9 in. x 12 in.

Engine Truck Wheels—Diameter, front 33 in.; journals, 6 in. x 10 in.; diameter, back,  $42\frac{1}{4}$  in.; journals, 8 in. x 14 in.

Wheel Base—Driving, 16 ft. 6 in.; rigid, 16 ft. 6 in.; total engine, 36 ft. 1 in.; total engine and tender, 66 ft.  $3\frac{1}{2}$  in.

Weight—On driving wheels, 221,500 lbs.; on truck, front, 23,800 lbs.; on truck, back, 40,600 lbs.; total engine, 285,900

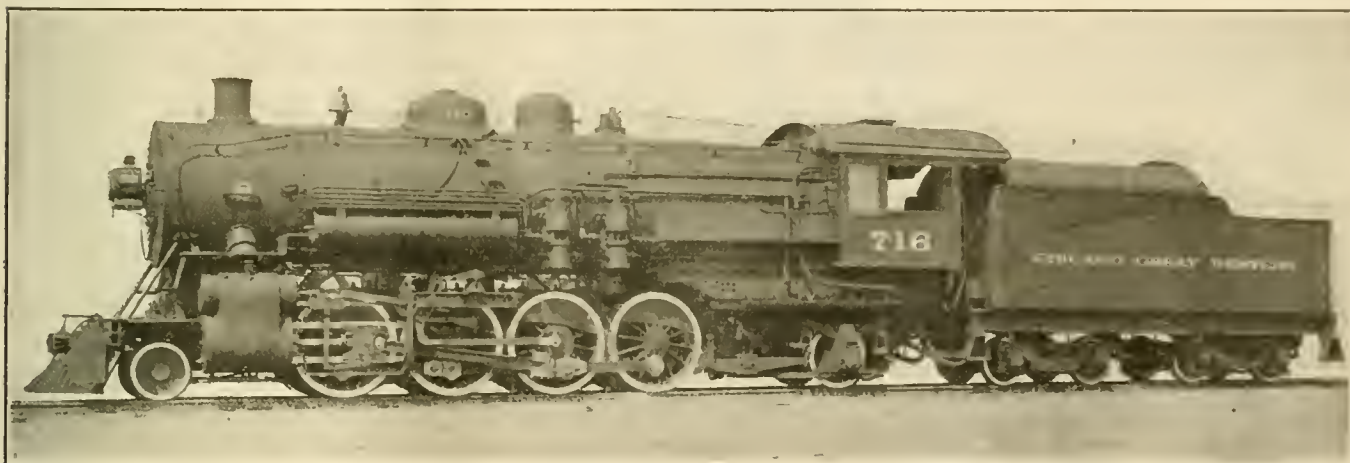

MIKADO 2-8-2 TYPE LOCOMOTIVE FOR THE CHICAGO GREAT WESTERN RAILROAD.

G. M. Crownover, Supt. Motive Power.

Baldwin Locomotive Works, Builders.

with 221,500 pounds on driving-wheels, the ratio of adhesion is 4.

The design of 1912 has a wide, deep firebox, which is placed back of the driving-wheels and over the rear truck, and is equipped with a brick arch. In the new design the Gaines furnace is employed, and the front of the mud ring is immediately above the rear drivers. The tubes have a length of 18 ft. 6 in. as against 20 ft. 6 in. in the earlier design. The brick-arch in the Gaines furnace is carried on four 3-in. tubes. The front end of the crown is supported by three rows of Baldwin expansion stays. Other features of the boiler and its equipment are a one-piece dome of pressed steel, "diamond" longitudinal seams, throttle with auxiliary drifting valve, and power-operated fire-door. The boiler tubes are welded at the firebox end.

The main frames are vanadium steel

ized pedestal design. The frame is composed of 12-inch longitudinal channels with cast steel bumpers. Sloping shields are placed over the fuel space on each side to prevent the coal from spilling.

Further particulars of these engines are given in the following table of dimensions:

Gauge, 4 ft.  $8\frac{1}{2}$  in.; cylinders, 27 in. x 30 in.; valves, piston, 15 in. diameter.

Boiler—Type, Straight; diameter, 82 in.; thickness of sheets,  $\frac{3}{4}$  in.; working pressure, 187 lbs.; fuel, soft coal; staying, radial.

Fire Box\*—Material, steel; length, 161 in.; width, 84 in.; depth, front,  $79\frac{1}{2}$  in.; depth, back,  $74\frac{1}{2}$  in.; thickness of sheets, sides,  $\frac{3}{8}$  in.; thickness of sheets, back,  $\frac{3}{8}$  in.; thickness of sheets, crown,  $\frac{3}{8}$  in.; thickness of sheets, tube,  $\frac{1}{2}$  in.

Water Space—Front, 5 in.; sides, 5 in.; back, 5 in.

lbs.; total engine and tender about 440,000 lbs.

Tender—Wheels, number, 8; wheels, diameter, 33 in.; journals,  $5\frac{1}{2}$  in. x 10 in.; tank capacity, 8,000 gals.; fuel capacity, 15 tons.

Service, freight.

\*Gaines furnace and combustion chamber. Length of grate, 116 in.

The tendency of trainmen to invent odd names for types of locomotives is very amusing, and it has sometimes been annoying to high-toned officials. All railroad men have been familiar with the names "grasshopper," "camelbacks," "crabs," and "hogs." Some art enthusiast belonging to a Western line, got up a neat red shield which was placed on every locomotive and car. The trainmen with one accord designated that number shield, "the liver pad."

# Air Brake Department

## P. S. Pneumatic Brake—Passenger Train Braking— Stopping Trains With Back-Up Hose

Some months ago we mentioned that the New York Air Brake Company had developed an electro-pneumatic brake for steam road passenger service, and stated

triple valve bracket, brake pipe vent valve, auxiliary reservoir, supplementary reservoir and brake cylinder along with the usual cocks piping and hose couplings,

### Passenger Train Braking.

Some months ago we printed a series of articles tending to lead up to the subject of passenger train braking, or rather handling passenger trains in road service, in a way calculated to produce the stop in the minimum distance and shortest space of time consistent with efforts to produce a smooth stop, and we intentionally delayed this matter until after the meeting of the Air Brake Association, knowing that an excellent paper on this subject was to be presented for discussion. From the remarks made at this time by the representatives of the various railroads throughout the country, it is evident that some of the past practices in brake valve manipulation have been discarded solely through an effort to devise some means or methods that would tend to produce a smoother stop even if some time and the distance of the stop would have to be sacrificed. The reader will recall that certain specifications for a train stop contained recommendations calling for a very heavy or full service application of the brake when the speed was high, and the brake cylinder pressure was to be reduced as the speed of the train decreased to the intent that the train could be brought to a stop with a low air pressure in the brake cylinders. This is an excellent practice and is read-

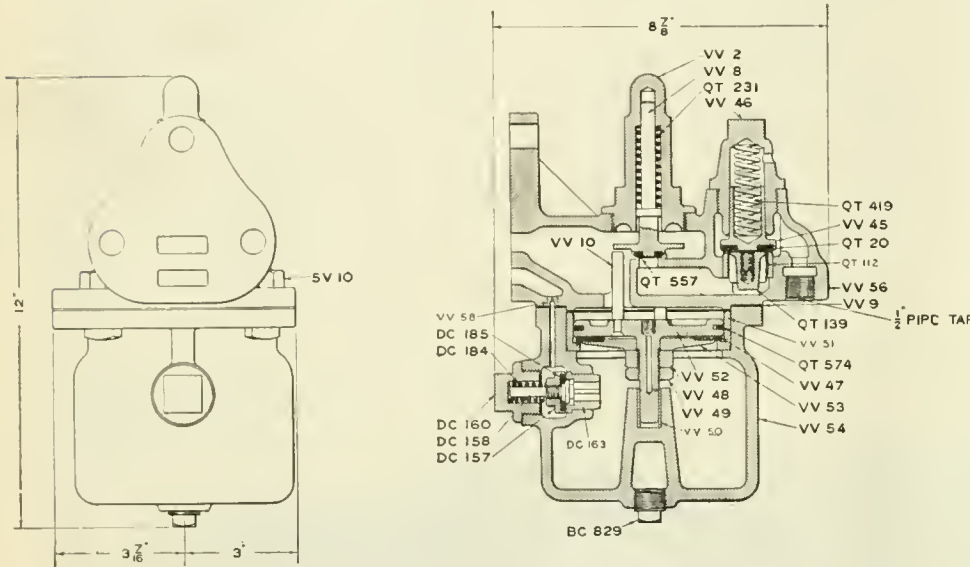

BRAKE PIPE VENT VALVE.

at the time that this apparatus would be described as soon as cuts were available for the purpose. At the present time it is desired to show only the general arrangement of the brake system and leave the description of the triple valve and vent valve for the next month's issue.

This company has recognized the fact that the constantly increasing demands upon the air brake, as a result of increased weight of cars and locomotives, higher rates of speed and congestions of traffic, necessitate a more powerful brake equipment having positive safety features and a greater range of flexibility than can be obtained with former types of brake equipments, and it is to meet these conditions that the P. S. electro-pneumatic car equipment is produced.

The electric operation will permit the highest attainable efficiency in stopping trains, the use of low voltage electric current giving instantaneous and simultaneous action to every brake regardless as to the length of the train, but pending the general adoption of the electrically operated brakes, the P. S. equipment without electric attachments is furnished, which will operate pneumatically in harmony with all previous types of pneumatic brakes, and when desired the electric portion may be added.

This brake consists of a triple valve,

and when it is desired to use electric current it is only necessary to add a portion containing a release, service and emergency magnet by bolting it to a portion

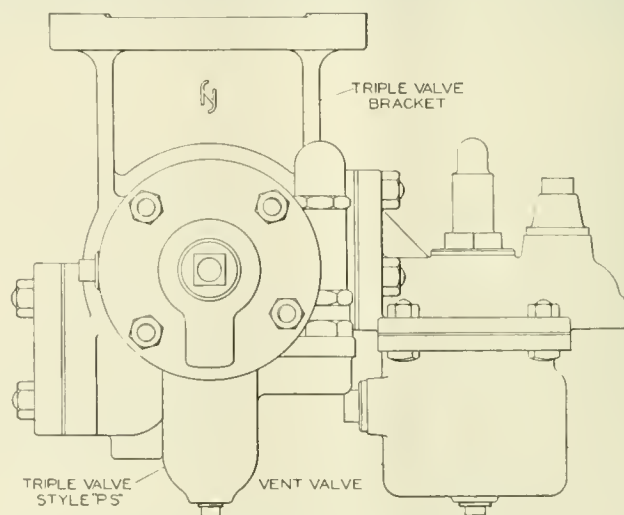

P. S. PNEUMATIC BRAKE.

on the triple valve bracket reserved for the purpose.

This apparatus is so constructed that there is but one size of brake equipment for any weight of car, and in next month's issue the operation of the different parts will be explained in detail.

ily accomplished when a graduation of release is employed as with the L. N. and P. C. brake equipments, but in some quarters the impression prevailed that the initial reduction was to be of not less than 20 to 25 lbs., which in itself tends to produce shocks in the train even if the speed



is high. It is now, however, unanimously agreed that the initial reduction should be what is termed a "split" reduction, that is, instead of one 20 lb. reduction in brake pipe pressure, two 10 lb. reductions should be made, or better yet, the

equal in opposite directions, the result of the trucks stopping will be to release the tension on the springs and throw the car bodies back to their proper positions on the trucks with the usual disagreeable lurch that it is so desirable to avoid. The

involves uniform retarding effect on the different cars in the train which cannot be obtained with very unequal brake cylinder pressure; however, if all brakes are applied and the brake cylinder pressure throughout is low it must be more or less uniform, but uniformity of brake cylinder pressure cannot be obtained if there is a very great difference in the length of the piston travel of the brake cylinders. If one brake cylinder piston travels 4 or 5 inches and another 8 or 9 inches, uniform retarding effect or a smooth stop cannot be obtained for the reason that the light brake pipe reduction for the second application of a two-application stop may develop from 5 to 8 lbs., brake cylinder pressure on the long travel and at the same time 30 or 40 lbs. pressure on the short travel and the difference sets up a difference in retarding effect and in the rate at which it is obtained, the result being that one car tends to stop before the other thus changing the rate of speed between the two or more cars, which in turn produces the shock and rough stop through the medium of the slack in the couplings of the train. This has been explained at some length in the report of the proceedings of the Air Brake Convention and in order to bring the matter down to a point where an attempted explanation will not be confusing from its length alone, the following methods to be employed in stopping a modern train equipped with the P. M. or High-Speed brake are generally agreed upon as being

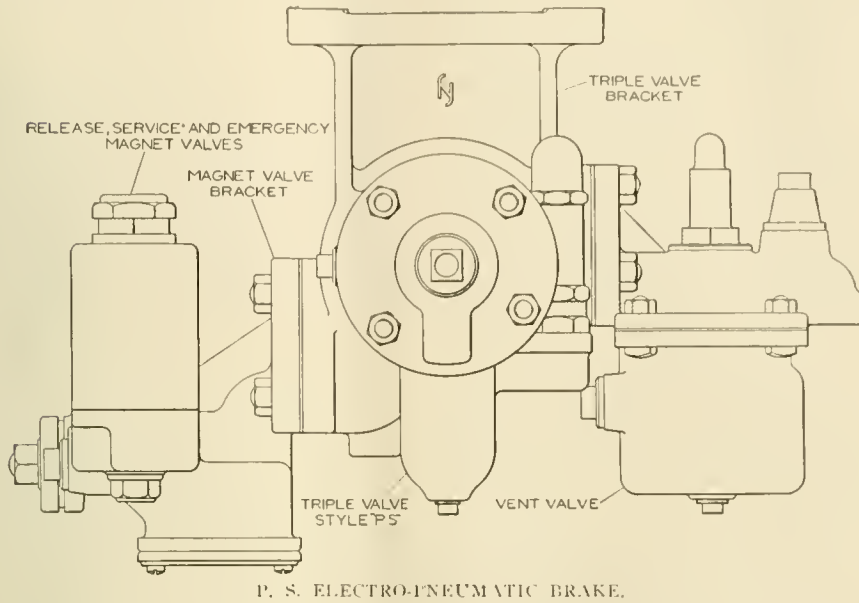

P. S. ELECTRO-PNEUMATIC BRAKE.

first reduction to consist of 8 or 9 lbs., and after the train slack has adjusted itself, the brake can be applied as heavily as desired or as conditions of service may require.

It is understood that a train cannot be

chief problem encountered in attempting the smooth stop is then obtaining a low brake cylinder pressure with which to complete the stop and as it is readily developed or reduced the desired amount with a graduated release type of brake, it

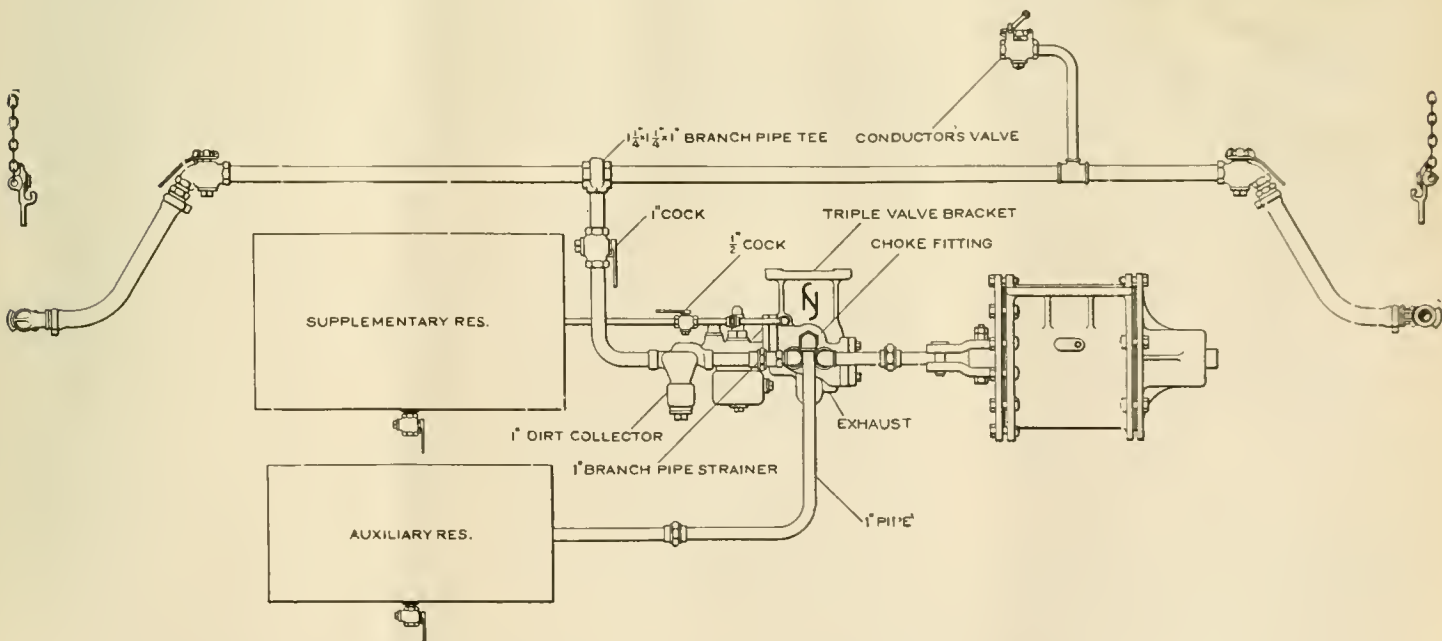

PIPING DIAGRAM OF NEW YORK P. S. BRAKE EQUIPMENT.

stopped smoothly with a very high brake cylinder pressure, for the reason that a high retarding force at a low speed tends to compress truck springs and certain portions of the draft gear in the train, and so long as action and re-action are

it is obvious that a triple valve equipment of the type P, or any brake without a graduated release feature, must be used with a two application method to result in a smooth stop. It will also be appreciated that a smooth stop with an air brake in-

good practice, tending to eliminate shocks in so far as it may be possible to prevent it by any manipulation of the locomotive brake valve.

The initial reduction to be somewhere between 6 and 9 lbs. to be governed by

the rate of speed at which the train is moving and by the make up of the train.

With heavily loaded express cars at the head end of the train or 6 or 7 lbs. is sufficient for the first reduction, but if lightly loaded baggage cars and day coaches are at the head end a somewhat heavier initial reduction is permissible.

After allowing time for the slack action to occur or to adjust itself, the second reduction should be made and the amount will depend entirely upon speed and make up of the train.

Under favorable conditions it is permissible to make any number of pounds reduction in the brake pipe pressure, following the initial reduction, to develop any brake cylinder pressure desired up to the maximum for service operation, but under what may be termed unfavorable conditions, some modification in brake application is essential to smooth handling.

From this viewpoint a favorable condition may consist of a solid train of Pullman equipment if all cars develop an approximately equal retarding force, or may consist of any train having a well designed equipment and foundation brake gear if cars are nearly equally loaded.

The unfavorable condition would be considered as one where the head cars in the train may be of express or other matter and loaded up with a load about equal to their light weight, which may also be aggravated by a somewhat low per cent of braking ratio employed on the locomotive. As an example, it is generally conceded to be good practice to employ a braking ratio for service operation on passenger cars that will be equal to 90% of the light weight of the car or to be more explicit, service braking ratio should be 90% based on a 24 lb. drop in the auxiliary reservoir and be obtained in 7 seconds time, therefore if coaches and Pullman cars are braked according to such a formula as well as the heavily loaded car, a load equal to the light weight of the car will reduce this percentage of braking ratio to one-half or 45%.

The retarding force set up by a brake application will be but one-half as much on the heavily loaded car as that of the lightly loaded or empty car. This difference also tends toward rough handling and in order to so far as possible offset these effects one railroad company specifies in their instructions that a brake application on such trains must be made by an initial brake pipe reduction of 6 lbs., and after a short wait for the slack to adjust itself this is to be followed by two more reductions of two pounds each, after which the reduction may be made as heavy as required. We might add that this road uses triple valves with quick service features and the 6 lb. reduction is ample to set the brakes throughout a modern length of train.

The effects of slack action and of shocks encountered during the initial reduction are not so pronounced or of nearly so much consequence as those that may be met with when bringing the train to a stop. Where a graduated release type of brake is in use, the pressure in the brake cylinders which is high at the beginning of the stop may be reduced or graduated out of the cylinders and with some practice the brake can be graduated off in such a manner that but one application of the brake during a stop will be necessary and the train may be brought to a stop with the brake cylinder pressure practically exhausted or at a pressure so low as to merely prevent any further movement of the cars. However, if the distance is slightly misjudged, two applications of the brake may be necessary, and if sufficient time is not allowed for the pressure to become entirely exhausted from all of the brake cylinders before the second application is attempted or if some of the cars are equipped with brakes having no graduated release feature, a rough stop is more than likely to result. As an example, if a two application stop is attempted while some of the brakes have released and some are still partially applied, a light reduction may result in very little pressure in the brake cylinders of the equipments that were completely released, while the same reduction may give almost full service braking power on the cars on which the brakes were still partly applied at the time the second application was started. The result of such a brake action cannot be anything but a rough stop, and the average man handling long passenger trains will appreciate the fact that some time must necessarily elapse between the movement of the brake valve handle and the complete release of the last brake in a 12 or 15 car train.

If the brake has no graduated release feature, a two application stop is absolutely necessary in order that the train may come to a stop with a low pressure in the brake cylinders. The air brake men recommend that this be done by releasing the brake when the speed of the train has reduced to 15 or 18 miles per hour, then by the time the brakes have released the speed will be still lower and the brake valve handle is to be brought from release position back to running position and be allowed to remain there a moment and then to lap position until the train reaches a point where it will be stopped at the desired point by a light second application.

If the graduated release type of brake is in use, which may be a U. C. equipment as well as the P. C. or L. N., the release is made by moving the brake valve handle to release position, or rather the graduations in brake cylinder pressure are to be made by first moving the brake valve to release position to insure that all of the

triple valves start to release position then the handle is brought to lap position and any further graduation of pressure out of the cylinders is made from lap to running position and back to lap. Release position should not be used except for the first graduation, and the movement to running position will reduce the pressure in the driver brake cylinders along with the pressure in the car cylinders.

The readers understand that train handling is a very broad subject and no recommendations are ever made for the purpose of covering more than one particular condition, or others similar to it, and in the foregoing it was only intended to point out what is generally considered to be good practice in brake valve manipulation when the chief consideration is a smooth stop. Previous articles have contained a great deal of information concerning the handling of passengers from a yard shifting point of view and the same can be employed to advantage in road service. The chief difference in handling the train is due to a higher rate of speed when the train is on the road, the rest of the matter relating to movements of the brake valve applies to either road or yard shifting service. The time of the brake valve handle in release position may be governed by other considerations than length of train, main reservoir and air pump capacity and the type of brake equipment in use, but these articles merely placed a time limit upon the brake valve in release position. In addition to what was printed at that time, we may say that one railroad's instructions are that with 10 cars or less the aim should be to have all of the brakes on the train released before the train comes to a stop, and if over 10 cars, the high brake cylinder pressure should be graduated down in such a manner that the train will be stopped with the lowest possible brake cylinder pressure obtainable. This again assumes a different proportion when two engines are handling a train because when the graduated release is attempted, the brake on the second engine will not graduate but rather release entirely unless there is an understanding between the engineers, and the one on the second engine prevents the release of his brake. Up to the present time the second engineer has not been requested to have an "understanding" or to assist the first man in making the stop, but instead the first man is instructed to make no attempt to graduate off the brakes on a double-header when the speed is less than 10 or 15 miles per hour. The same instructions also specify that if a two application stop becomes necessary through some unforeseen occurrence, or through refusing to graduate the brake off with a double-header at a speed lower than 10 or 15 miles per hour, sufficient time must elapse between the application to permit the

brake cylinder pressure to be entirely exhausted before the second application is attempted.

Starting a train without severe jerks or shocks is sometimes a more difficult matter than stopping the train without the shock, therefore an excellent rule to be followed in starting a train when it is necessary to take the slack is to apply the independent brake and move the reverse lever in the direction in which the slack is to be taken, graduate the independent brake off, and allow engine to drop back against the train. All the slack should be taken and the reverse lever should not be moved in the opposite direction until after the train comes to a stop. This is to prevent the train from moving in the opposite direction when the engine is given steam, and in this manner heavy shocks and damage to draft gear may be avoided.

#### Stopping Trains with Back-Up Hose.

Undoubtedly the most frequent complaint that is made to the Railroad Companies by the traveling public is the rough handling of passenger trains and we have devoted considerable space to an effort to sum up the reasons for rough handling of trains. And it will be remembered that the rough stop is not always due to the manner in which the brake valve is handled, in fact there are certain conditions under which a train cannot be handled smoothly no matter how the brake valve happens to be manipulated.

During this time it was pointed out that in order to insure a smooth stop with the air brake, at least two essential conditions must be obtained: first, a uniform retarding effect on the different cars in the train, and second, a low brake cylinder pressure or rather a low retarding effect on all of the cars. If this desirable condition can be obtained a smooth stop is within the range of possibility.

When a passenger train is backed into a station, a back-up or rider hose is attached to the brake pipe at the rear end of the train so that a brake application may be made by anyone riding the platform of the rear car, to which no objection can be offered as it is rightfully required by law, but the general practice is to use this back-up hose for operating the brakes while a passenger train is backing into the station.

When a brake application is started with a valve at the rear end of the train, with the brake valve on the locomotive necessarily in running position to make possible a release of brakes when required, a peculiar air brake proposition is presented. While the brake pipe pressure at the rear end of the train is being reduced with a valve having the same functions of the old style three-way cock which was discarded from the locomotive years ago because with it a uniform re-

duction in brake pipe pressure of a desired amount was practically impossible, a feed valve on the locomotive is open expanding compressed air from the main reservoir into the brake pipe at a rate of from 30 to 65 cubic feet of free air per minute. This tends to maintain the pressure in the brake pipe on the head cars while the reduction is taking place on the rear cars, therefore a brake application yielding as much as 40 or 50 lb. brake cylinder pressure may occur on the rear cars while the head cars in the train may be moving with the brakes practically released, and just how a uniform retarding effect can be obtained under such conditions is not altogether clear. It is also difficult to imagine under what conditions a low brake cylinder pressure can be obtained on the rear cars during the stop if the brakes on all of the cars in the train are to be applied.

It must be admitted that a fairly respectable stop can be made if some outside forces are utilized, such as keeping the engine throttle open to the stop, which will under certain conditions keep the slack bunched or keep the cars shoved against each other so that the run in or collision that usually results cannot occur. With a long passenger train this is exceedingly difficult and a smooth stop is seldom made with the back-up hose and from an air brake point of view, this is what would be termed a "bone headed stunt," that is, attempting to make a uniform brake pipe reduction with a stop cock at one end of the brake pipe while compressed air was entering the other end of the pipe.

For such purposes the engineer is provided with a brake valve that will mechanically measure the volume of compressed air to be exhausted from the brake pipe and it should in all cases be used for this purpose save in the event of an emergency when a stop is the chief consideration and smoothness of secondary importance.

For the above reasons we take the stand that a back-up hose is an emergency device and should be used only in cases of emergency and when an ordinary stop is desired the Engineer can make it on a hand, lamp or communicating signal, and if the hand signal is not observed or if the signal whistle becomes inoperative there will be plenty of time left in which to use the back-up hose.

If it is desired to eliminate some of the rough handling of passenger trains at stations an excellent start can be made by forbidding the use of the back-up hose except in cases of emergency, and when it is used the fact should be reported with a complete explanation of the circumstances leading up to it.

Let him that regrets the loss of time make proper use of that which is to come.

#### Dispute Between Trainmen and Their Employers.

For several weeks a conference has been going on in New York City between representatives of the leading railroad companies of this continent and of the four leading train employee's brotherhoods, viz.; The Brotherhoods of Locomotive Engineers, the Brotherhood of Trainmen, the Brotherhood of Locomotive Firemen and Engineers, and the Order of Railroad Conductors.

The train employees are demanding higher pay and shorter hours of labor while the railroad companies have taken the stand that railroad trainmen are better paid than any other class of labor, but display a willingness to make some concessions in the interests of harmony and fair dealing.

After a long conference lasting over three weeks in which both sides fought for their demands with great good nature Elisha Lee, representing the railroad companies' side, said: "In our judgment, no reason developed during our conferences to justify the extraordinary changes in operating methods and practices, and the large expenditures for additional facilities which your proposals involve; nor was anything presented to justify your requested radical revision of the established basis of compensation and favorable working conditions. Moreover the best obtainable estimates indicate that to accept your proposals would increase the cost of operation of the railroads approximately \$100,000,000 a year, all of which must eventually be borne by the public."

Mr. Lee concluded by proposing that the matters in dispute be submitted to arbitration.

Mr. A. E. Garretson, president of the Order of Railroad Conductors, speaking for the four organizations of trainmen, declined to consider arbitration, and the conference was adjourned. The intention now is for the representatives of the employees numbering about 350,000 persons is to vote on a strike.

The next conference can have one of three results, the surrender of the railroads to the demands of their trainmen, a strike, or arbitration.

#### Industry vs. Idleness.

The happiness of the people at large should be constantly promoted by every State. As this happiness depends very much upon the character of the people's employment, the State should recognize, encourage and foster every enterprise that offers its industrious citizens an opportunity to support themselves in comfort and to secure to their children by superior education and better associations a fairer chance than they had at the beginning of life.

## One Thousand Hopper Cars for the Erie— Longitudinally Braced With Outside Members

The standard design of car used by the Erie Railroad for transporting coal is what is known as a self-clearing triple hopper bottom gondola car. By referring to the photograph herewith which shows one of these cars, 1000 of which have recently been built by the Pressed Steel Car Company, it will be noted that the bottom is equipped with three sets of doors. Each opening is provided with two doors hinged crosswise of the car. The doors are opened in multiples of four, that is two pockets, one on each side of center sill, are operated from one operating shaft. With this arrangement of hoppers, larger and more direct openings for discharging the lad-

to the end of the body bolster girder. Between the bolsters the sides are braced on the outside with four longitudinal members. One is at the top of car and consists of a  $4 \times 3\frac{1}{2} \times 1\frac{1}{2} \times \frac{3}{8}$ -in. bulb angle continuous from corner post to corner post. At the bottom of the side is a  $3\frac{1}{2} \times 3 \times 5/16$ -in. rolled angle extending continuous between two points, just beyond each body bolster. Between these two rolled members and spaced about equally are two pressed steel stiffeners extending from bolster to bolster. On the inside there are two heavy triangular shaped gusset plate braces. These extend from the top of sides to the cross girders

the top with an angle extending between the side gusset plates which are attached to the top of these plates. To this plate, about in line with top of center sills, are also attached four sheets which slope down to and form one side of the door opening to which the drop doors are hinged. The center sills consist of 15-in. 33 lb. rolled channels, with the flanges turned in, reinforced at the bottom on the outside with a  $3\frac{1}{2} \times 3\frac{1}{2} \times \frac{3}{8}$ -in. angle extending from draft rigging to draft rigging. To these sills, in front of the body bolster, are spliced  $\frac{3}{8}$ -in. thick pressed steel draft sills. The body bolsters are of the usual single web construction. The

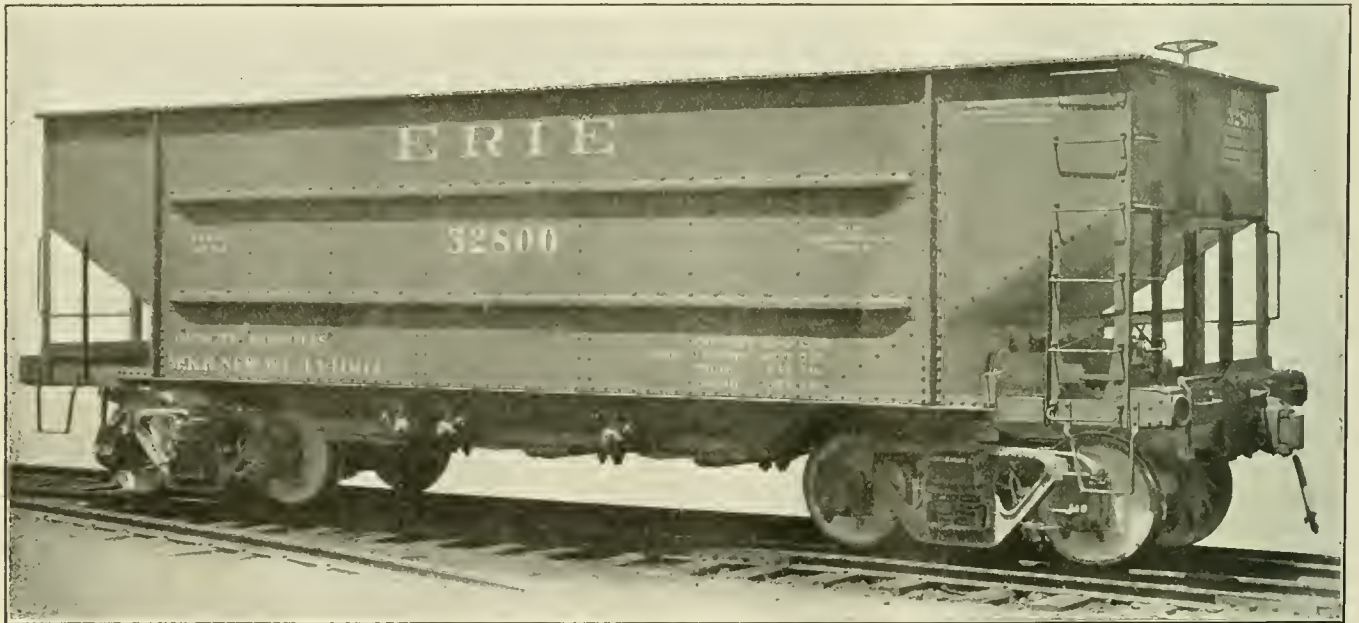

TYPE OF SELF-CLEARING TRIPLE HOPPER BOTTOM CARS FOR THE ERIE RAILROAD. PRESSED STEEL CAR COMPANY, BUILDERS.

ing are obtained. The total opening is from 30 to 50 per cent. greater than with the standard double hopper bottom type of car and, therefore, the lading can be discharged more rapidly and with less labor.

These cars have a special feature in the construction and bracing of sides. It is known that where outside vertical stakes and inside tie braces tying the sides together are used these are always sooner or later damaged, the side stakes from being side brushed and the tie braces from the lading. The sides on these cars are braced entirely different from the usual practice, and instead of using outside vertical side stakes spaced at regular intervals between the bolster, and bracing the sides by tying them together with tie braces, the main bracing on the outside is longitudinal and on the inside vertical. There are two pressed steel stakes on each side, one at each bolster. These two stakes are well braced, being anchored

and have a width at the bottom of about one-half the distance between the side and center sills. There are four additional vertical stiffeners made of angles on the inside spaced equally between the bolster and the triangular shaped gussets. It is found that this construction stands up very well and repairs are small when compared to usual construction of having all vertical side stakes on the outside and having inside cross tie braces.

With the exception of the end sheet, the end side sheet and the end sill cover plates, which are  $3/16$ -in. thick, the plates used throughout are  $1/4$ -in. The cross ridges, which at the same time form cross girder constructions, each consist of a vertical web plate running from side to side of car and in depth from the bottom to about 20-in. above the top of center sills. These are reinforced at the bottom with two angles extending from side to side which pass below the center sills and at

end sills consist of 9-in.,  $13\frac{1}{4}$  lb. rolled channels, well backed with a heavy steel casting behind the coupler horn striking face.

The specialties used are New York Air Brakes, Simplex, Gould and National Malleable Casting Co's. couplers, Reliable uncoupling device and Miner Friction draft gear with forged steel yoke. The trucks are of the cast steel side frame type, having  $5 \times 5 \times 1/2$ -in. spring plank angles and are equipped with Simplex Bolsters having Miner side bearings, M. C. B. brake beams, steel back brake shoes, Barber roller device, grey iron wheels, Gould journal boxes and dropped forged wedges. The length over coupler striking face is 32 ft.  $4\frac{1}{2}$ -in., the highest from rail to top of side 10 ft.  $6\frac{1}{4}$ -in. and the width over all 10 ft.  $1/4$ -in. The cars are of 100,000 lbs. capacity, level full hold 1880 cubic feet and weigh 41,000 pounds. The material is of the best.

# Two Hundred Automobile Cars for Wheeling & Lake Erie Equipped With Doors Ten Feet Wide

The Wheeling & Lake Erie Railroad Company have recently purchased from the Pressed Steel Car Company 200 automobile cars. These cars are of the single sheathed type having steel under and upper framing. The underframe in itself is not intended to carry any load except in so far as it transfers the load distributed over the floor to the girder or truss formed by the side framing of the car. The center sills are built to resist buffing only, consisting of 12-in. rolled channels weighing 35 lbs. per foot, spaced 12 $\frac{7}{8}$  in. back to back with the flanges turned outwardly and extending from end sill to end sill. They are tied together and reinforced at the top with a  $\frac{1}{4}$ -in. cover

and side sills and having a steel casting between the center sills with 14 x  $\frac{1}{2}$ -in. top and 14 x 7/16-in. bottom cover plates. The floor is of 1 $\frac{3}{4}$ -in. tongued and grooved yellow pine, resting on the side and center sills, and on two intermediate yellow pine stringers.

The side framing of these cars consists of an angle extending from end to end, forming the side plate to which is riveted a 12 x  $\frac{1}{4}$ -in. plate extending from corner posts to door posts for use in attaching the side posts and braces which are 3-in. 67-lb. rolled Z bars. The door posts are 4 x 3 $\frac{1}{2}$  x 5/16-in. rolled angles. These members, together with the side sill channel, form the carrying truss of the car. The

plate of the car and one at the bottom for riveting to the end sill. This bottom flange also supports the floor at the ends, making the car grain tight. The roof is the outside metal type, having rolled tee carlines. The inside measurements of the car are 8 ft. 6 in. x 40 ft. 5 in., the height from rail to top of running board is 13 ft. 8 $\frac{7}{8}$  in., the width over all 9 ft. 11 $\frac{1}{2}$  in., and the length over striking plate 42 ft.  $\frac{1}{2}$  in.

The cars are equipped with the following specialties: Westinghouse Air Brakes, Sharon Cast Steel Couplers, Carmer Coupler Release Rigging, Imperial Appliance Company's Coupler Centering Device and Miner Friction Draft Gear with Two-Part Cast Steel Yoke having Key Attachment. The trucks are the Bettendorf having Cast Steel Bolsters with Stucki Side Bearings, Barber Lateral Motion Device, Grey Iron Wheels, M. C. B. No. 2 Brake Beams and Steel Back Brake Shoes. The cars are of 80,000 pounds capacity and weigh 42,600 pounds.

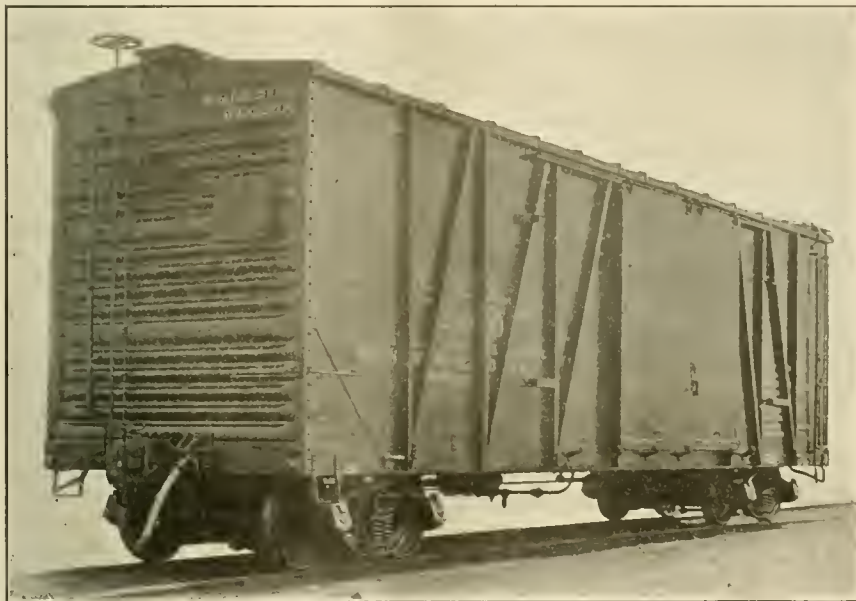

TYPE OF AUTOMOBILE CARS FOR THE WHEELING & LAKE ERIE RAILROAD. PRESSED STEEL CAR COMPANY, BUILDERS.

plate running their whole length. The sills are located 2 ft. 4 $\frac{1}{2}$  ins. from rail to bottom of flange, under which condition they meet the M. C. B. requirements of area and ratio of stress to strain. The end sill arrangement consists of a heavy steel casting around the coupler opening forming the striking plate with short 10-in. rolled channels weighing 15 lbs. per foot end sills extending between the striking plate and the side sills. They are tied to the side sills, which are also 10-in. 15-lb. rolled channels, with malleable iron push pockets. There are seven floor beams consisting of flanged diaphragms made of  $\frac{1}{4}$ -in. pressed steel, located between the center sills and between the center and side sills. Each of these is reinforced at the top and bottom with 5 x  $\frac{3}{8}$ -in. plates. The body bolster is of the box type, made of  $\frac{1}{4}$ -in. pressed diaphragms, located between the center

siding is 1 $\frac{1}{2}$ -in. thick tongued and grooved yellow pine, bolted to the inside of the side frame members with  $\frac{1}{2}$ -in. carriage head bolts. Each side of the car is provided with a 10-ft. door opening, equipped with double doors, arranged that an opening of either 6 ft. or 10 ft. may be obtained. The center of the 10-ft. openings are 2 ft. 6 ins. off the center of the car, located diagonally opposite. The doors are made of yellow pine sheathing and framing 13/16 in. thick and are equipped with Camel fixtures. It is thought that end doors are not absolutely necessary and as they are always more or less a source of trouble where used the ends of the car are made of solid steel of the Murphy type. These are riveted to rolled angle corner posts which are tied to the side sills with diagonal tie straps. Each end is provided with a flange at the top to form the end

## Armor Plate.

The Government never built anything as cheap or as expeditiously as does the private individual, and yet we are threatened from certain quarters with the establishment of a government plant for the construction of armor plate. Surely there is enough common sense left to see the gross injustice in encouraging private enterprise in establishing great industries and then considering means for their destruction. Not only would the manufacture be more costly in governmental plants, but a new army of office-holders would be created like barnacles on the body politic. Of this kind of cattle we have more than enough already. What we need is encouragement in open and honest competition and the enterprise of the American people will do the rest. The best government is that which governs the least. Governmental bureaus have never been a success in manufacturing anything, and never will.

## Master Track Scales Tested.

Bureau of Standards Test Car No. 1 began several weeks ago the testing of master track scales in various Southern and Western States. While on this trip it also gave attention to other track scales. Work has been done in North Carolina, South Carolina, Tennessee, Alabama, Mississippi, and Texas. Some of the master scales are located at great distances apart and the tests are made in greater detail and consequently take more time than ordinary track scales.

# Electrical Department

## Catechism of the Electric Locomotive Continued

Q.—What is used to hold the contact shoe against the third rail?

A.—Springs.

Q.—Where are these springs located?

A.—Referring to Fig. 3, spiral springs (A) are used, through which passes the bar (B), this bar being held in the casting (C).

Q.—What arrangements are provided to adjust the shoe at the proper height?

A.—In the type of third rail shoe construction shown by Fig. 3 an adjustment is provided so that by loosening the bolts (D), of which there are three, the casting can be raised or lowered, giving the necessary adjustment.

Q.—Is this arrangement universal?

A.—No. Many times there are no adjustments in the casting (C) referred to, but the adjustment is taken care of by adjustment in the support which carries the third rail shoe beam.

Q.—What do you mean by the third rail shoe beam?

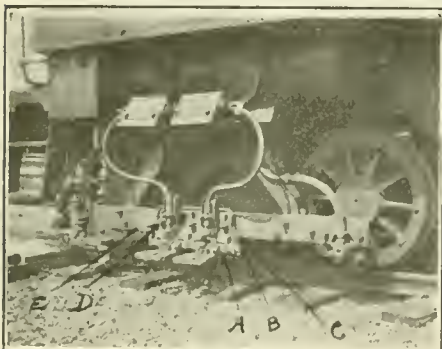

FIG. 3.

A.—The third rail shoe beam is shown by (E) on Fig. 3, and is the beam to which is fastened the casting carrying the third rail shoes.

Q.—Of what material is this third rail shoe beam constructed?

A.—It must be constructed of an insulating material, usually of wood.

Q.—Why is this necessary?

A.—When the third rail shoes are in contact with the third rail, they are "alive," and all of the casting is also "alive." Sufficient distance must be given between the casting and the point of support which is "ground" so that the electric power will not creep along the shoe beam even when exposed to dirt, moisture, snow, etc. It is thus important that the shoe beam be kept clean and properly painted with an insulating paint so as to prevent this creepage.

Q.—What particular point is borne in

mind when mounting these third rail shoe beams?

A.—Beams must be mounted on brackets, which are carried on a truck member which is stationary, or directly on to the journal boxes on locomotives which are constructed differently from those shown in Fig. 3, so as to keep the shoe beam at a constant distance above the rail. The shoe beam should not be hung from any part of the locomotive which is liable to variation in distance from the rail on account of spring variation.

Q.—Why must the third rail shoes not be mounted on spring-board parts of the locomotive?

A.—Because with this arrangement of mounting there would be a variation in the distance of the shoe beam above the rail and, hence, correct adjustment of the third rail shoe pressure on the third rail could not be obtained due to the variation.

Q.—What do you understand by "creepage"?

A.—Voltage, as we have seen, is analogous to pressure and the distance which the electric current will jump through the air varies with the voltage, but this distance is extremely small in connection with 600-volts, being a very small fraction of an inch, for even with 11,000 volts, the distance is only something like  $\frac{1}{4}$  inch. Although the distance the current will jump with 600 volts in the air is very small, still the creepage distance may be much greater and depends on the condition of the surface over which the current creeps. Take, for instance, the third rail beam condition: If this wooden beam is wet and covered with dirt, the voltage may actually cause the current to "creep" several inches along the surface of the beam to ground, thereby causing a short circuit. No creepage would exist if the beam were clean and dry.

Q.—How is the current taken from the third rail shoes into the locomotive?

A.—By means of electric conductors or cables.

Q.—Describe the construction of cable.

A.—It consists of a centre part, of copper wires in large numbers, so as to give flexibility. Around this copper centre is placed a wall of rubber which has been vulcanized so that it is of one continuous piece. Over this rubber are woven two or three cotton braids, these braids serving as a protection to the rubber wall.

Q.—Does the cable, or what is known as "shoe lead," pass directly from the third rail shoes into the locomotive?

A.—No. The lead goes from the shoes to a fuse-box.

Q.—What is the function of the fuse-box?

A.—The fuse-box is placed in the circuit for protection to short circuits and is placed as near as possible to the third rail shoes.

Q.—What is the object of placing this third rail shoe box near the shoes?

A.—In order to cut down to as short as possible, the length of cable between the shoes and the fuse-box, thus leaving the minimum amount of cable unprotected.

Q.—How many sets of third rail shoes are usually mounted on a locomotive?

A.—There are usually four sets, two on either side at the ends of the locomotive.

Q.—What is the object of placing them at the ends of the locomotive?

A.—To get them as far apart as possible, so as to breach as many gaps in the third rail as possible.

Q.—Explain what you mean by "gaps in the third rail."

A.—It is readily seen that at cross-

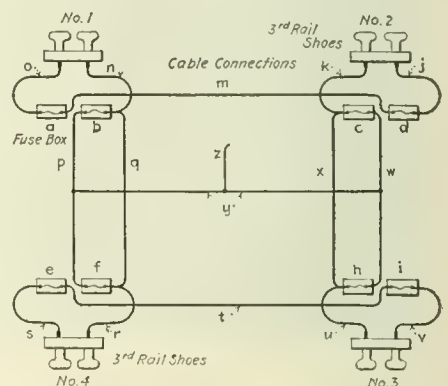

FIG. 4.

overs, intersections, switches, etc., it is impossible to carry the third rail as a continuous conductor and there are, therefore, gaps or spaces through which the locomotive must coast without taking power. With the third rail shoes as far apart as possible the time which occurs from the breaking of the rear shoe to the making of the forward shoe across the gap is cut to a minimum.

Q.—Are the sets of third rail shoes on the two sides of the locomotive interconnected?

A.—Yes, usually these shoes are all connected together, so that when one shoe is touching the rail, all other shoes are "alive."

Q.—Fig. 3 shows two fuse-boxes mounted on the truck. What is the object of more than one fuse-box?

A.—The arrangement on this particular electric locomotive and one which is

usually employed in all electric tramways is such that the electric current taken by the locomotive is drawn through the trolley-boxes in the locomotive, even if one or more sets of trolleys are in contact with the third rail.

Q.—What is the object of this arrangement?

A.—With this arrangement the trolley used in the trolley-box can be of much lower capacity than that of the current taken by the locomotive, and drawn through one trolley-box when that particular set of trolleys has the only set of trolleys in contact with the third rail. For instance, assume that the maximum current taken by the locomotive is 1,000 amperes. Under the condition of one set of trolleys only touching the third rail, the capacity of the trolley would have to be of excess of 1,000 amperes and of sufficient capacity to handle the current for the period of time which the locomotive might require to start up a heavy train and until the second set of trolleys in the same side zones in contact with the third rail. By connecting in the trolley-boxes on the opposite side of the locomotive from the set of trolleys in contact with the rail, the current drawn by the locomotive is divided among the trolley-boxes and so that half of these have a parallel handling the current, then 500 amperes would be the amount going through each trolley and therefore a trolley set of 500 amperes capacity could be used instead of one or two 1,000 amperes. When both sets of trolleys are in the third rail, in case of the right-acting condition of 1,000 amperes capacity, 500 amperes would have to be taken by the locomotive before the trolleys would draw and the protection afforded by the trolley-boxes is not drawn materially due to the capacity of the trolleys. No larger trolley than is necessary should be used, so that in case of trouble the trolleys will draw immediately, thus removing current from the locomotive and preventing excess damage. Fig. 2 shows an arrangement of this kind. The four sets of third rail shoes are shown as No. 1, No. 2, No. 3 and No. 4, these being located at the ends of the locomotive. The trolley-boxes are shown as A, B, C, D, E, F, G, H, I, J, K, L, M, N, O, P, Q, R, S, T, U, V, W, X, Y, Z, and are connected up with the third rail shoes and with each other as shown by the cable connections in the diagram.

With this arrangement the current taken by the locomotive through the trolley-boxes passes through four trolley-boxes, namely A, B, C, D, and E, regardless of whether one set or third rail shoes or more are in contact with the third rail. Referring to the figure assume that only the No. 1 set of third rail shoes is in contact with the third rail. The flow of the electric current through the cable, etc., is then as follows: Current passes up through the cable in the main going through the trolley-box A, along the cable

and hence through the trolley-box B, the current then passes along the cable to the trolley-box C, through the cable and hence to cable V, and a cable W. The current which passes in the cable runs the third rail shoe No. 1, goes through the trolley-box F, hence to the other end of the locomotive through the trolley-box G, making the No. 2 set of third rail shoes 'alive' through the cable H, and through the cable I, to trolley-box J, through the trolley-box K, cable L, and hence to cable M, and N. Referring back to cable V, the current goes through the cable mentioned before part of which goes through trolley-box O, and moreover cable connected by cable P, to third rail shoe No. 2, hence along cable Q, to trolley-box R, where it passes to trolley-box S, hence to the No. 3 set of shoes to trolley-box T, and through cable U, to cable V, and F, on the above you can see there are four circuits with one set of shoes in contact.

Q.—What type of trolleys are usually used in these trolley-boxes?

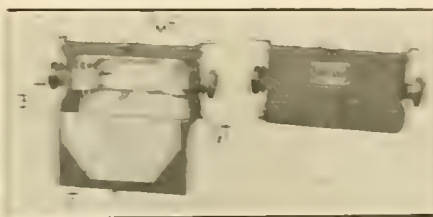

FIG. 2

3.—Trolley trolleys

Q.—How are these trolley-boxes constructed?

A.—Referring to Fig. 3 the trolley-box is shown with the front open and shows the method used in clamping the trolley trolley into position. The trolley-box when correct draw in the wedge-shaped blocks U, and the jaws V, thereby clamping the trolley trolley in position. The leads carrying the current enter the jaws W, at the back of the trolley-box.

Q.—Are the trolley trolley mounted throughout the length?

A.—No, in the center a cut is made.

Q.—What is the purpose of this hole?

A.—To cut down the cross section of the trolley trolley at the center portion, giving it the right current carrying capacity and so when the trolley trolley will open up at its weakest point.

Q.—What is your understanding of the trolley trolley?

A.—When current of such value flows through the trolley trolley heats same up at the weakest part to a melting point and the trolley trolley is actually melted into two parts.

New Trolley Shoe

A new sliding contact or shoe instead of trolley wheels has recently been placed on the market by the United

States Company, which is of the same type as shown in Fig. 4, page 287.

This contact shoe is supplied with a traveling shoe which maintains contact with the trolley and water wheels or intermediate bars. The contact shoe is made of an unusually close grained steel, and has a hardened surface which will not 'burn' against the trolley shoe, so that it will not wear in under severe loads. In service these shoes have been giving in service in conditions not high contact, and one 1,000 amp high-speed line a record of 2,000 miles per single contact was obtained, which reduced the contact wear to 1/100th of an inch per 100,000 miles or 100 cents. The price of the manufacturer claims that the shoe is 100% more than the cost of the material. Such close grain, and oxidizing qualities require and must be rubbed or rubbed with a fine sand paper, and without any wear being required.

Another interesting feature of the shoe is the fact that it operates with a base material of angle iron, and is for use in service. The reduction in the average contact is 1/10 at 4 lbs with a wheel, not only reduces the pressure on the contact, but also reduces the pressure on the overhead.

In locomotive service this shoe has shown that it will operate satisfactorily through curves and on curves either forward or backward. It will also operate on any overhead now installed for the use of a revolving contact, and in many places of overhead used with a pantograph or bow trolley, without any changes being made.

This method of current collection, it is claimed, also eliminates the hazard of neck climbing or the need of oil, since the use of wheel pushings eliminates the nuisance of oil on the road, and removes the annoying hum and pounding caused by wheels striking a tight sheet.

Since this device has been introduced it has been adopted as standard by over 25 prominent railroads. The weight is about 4 lbs each. The shoes and the shoe are made of high-grade manganese steel. Each shoe is provided with current collector insulated spring to keep the contact parallel with the wire, and the base is designed to fit a standard 1-in. pin.

Mr. Topsy Payne, seated by a passenger in a railway carriage, "What time is it by your watch, if you please?" Stranger: "I don't know." Mr. Topsy Payne: "But you have just looked at it." Stranger: "Yes, I only wanted to see if it was still there."

# Type of Pressed Steel Car Company's "Fox" Truck

It is perhaps not generally known that before the period when steel cars were manufactured there was developed a type of pressed steel pedestal truck known as the "Fox" type, which has proven from long years of service to be unusually economical in regard to maintenance charges. This type of truck embodies in its construction principles which provide strength with economy and being made of more strictly homogeneous material, possesses a reliability that is not present in other types and is free from possible defects in manufacturing variations.

Marked improvements have been made from time to time, and as now manufactured by the Pressed Steel Car Company is attracting wide attention among railroad men on account of its reliability in heavy traffic, and a brief description of its general features seems proper at this time.

needed at bottom ends to floating beam which carries the springs, either helical or elliptic, and seats supporting an independent bolster, with lateral adjustments to suit the requirements of the service.

The accompanying drawing shows the general design of the latter type. The side-frames are designed to carry, with a fibre-stress not exceeding one-half the elastic limit of the metal, the full M. C. B. rated carrying capacity of both axles in the truck as a centrally superimposed load. This is 100 per cent. in excess of actual static loading on each side-frame permissible under M. C. B. rules and provides ample material strength to resist the combined effect of vibration under rolling load, and lateral thrust due to curving, in which wheel flange stresses as great as 25,000 pounds may occur. The transoms and pedestals are designed to resist the

33 in. or 36 in. diameter wheels can be used in connection with any existing design suited to standard gauge trucks for steam railroad service.

The working value of any truck, from both operating and maintenance standards, rests in its stability under rated load with inherent flexibility to meet all operating conditions without distortion of parts, and free equalization, both transversely and longitudinally, to insure correct alignment and contact of journal bearings and practically uniform wheel loads. Important features also are the minimizing of the number of separate or bolted parts, as well as the accessibility of parts for adjustment of height, or changing of wheels and axles, and other parts.

The quality of free flexibility without distortion provided by Fox trucks rests in the spring support for frame which imposes the weight centrally of the axle

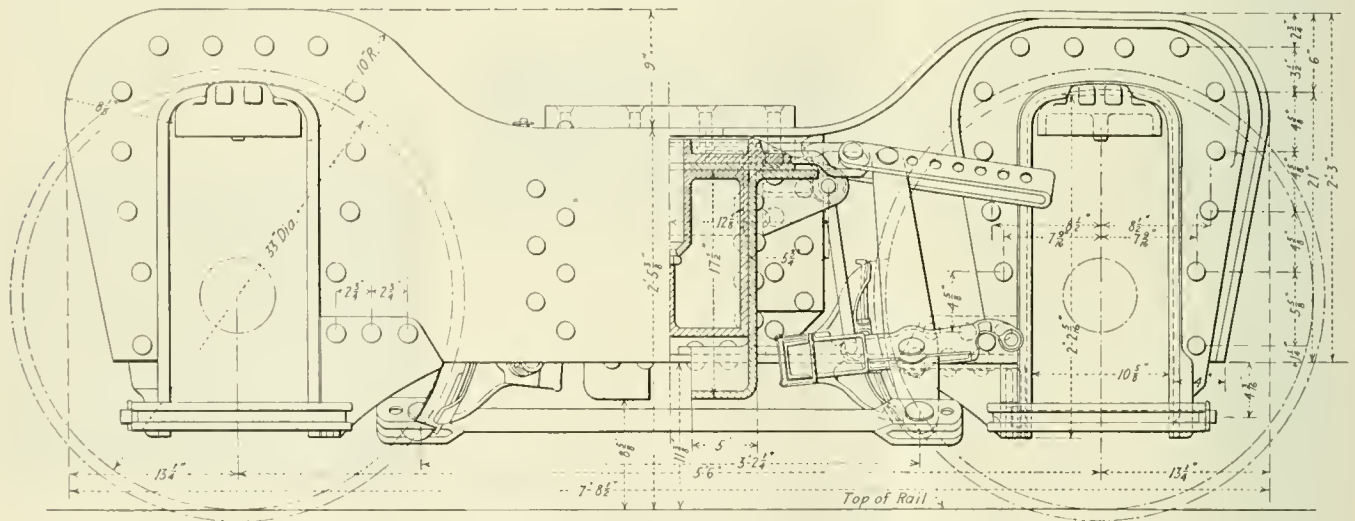

SWING-MOTION TYPE OF FOX TRUCK FOR LOCOMOTIVE TENDERS.

There are three distinct types. The ordinary freight car type, without bolster, is essentially a four-piece construction, consisting of two side-frames connected by two transoms which carry the center-plate and side-bearings. Helical springs are used over the journal boxes to carry the weight, cushion against shocks and provide equalization. This is the simplest and cheapest form.

The type used on locomotive tenders is similar to the ordinary freight car truck, but is provided with stirrup-hangers from transoms which carry springs, either helical or elliptic, and seats supporting an independent bolster. Lateral play is provided at each end of the bolster to suit requirements.

The swing-motion type for cars in locomotive tenders are provided with a swing-motion device, either pin or lug supported, with long hangers con-

same ratio of pressure. The latter are reinforced with steel castings to insure uniform alignment and stability, provide ample area for journal box wearing shoe and spring-seat bearings, and are maintained in correct position at bottom of jaws by cast steel driving-fit, pin-supported clamping binders designed for quick application or renewal.

A great number of these trucks equipped with M. C. B., 4 1/4 ins. by 8 ins., 5 ins. by 9 ins., and 5 1/2 ins. by 10 in. axles, the first two mentioned having 5 ft. 3 in. wheel base and the latter 5 ft. 6 ins., are in service on various railroads under cars and tenders ranging in gross loaded weight from 96,000 to 162,000 pounds, and 5 ft. 6 in. wheel base designs suitable for use with 6 in. by 11 in. axles under cars or tenders with gross loaded weights up to 213,000 pounds are ready. Either

journals, and by means of the elasticity of the springs permits the rise or fall of the axle without the twisting and shearing action resulting from right construction which experience has shown are constantly tending to work spring-beam constructions loose. The equalization feature is provided by the spring support for frame which furnishes positive elastic cushion to absorb checks and attendant stresses set up by rough track and speed in running, and permit the frame to automatically adjust its position without restricting wheel or axle movement, or creating any marked difference of uniformity in wheel loads.

In regard to the number of separate or bolted parts, the Fox trucks occupy an unusually enviable position in comparison with other trucks. In the arch-bar truck the separate or bolted parts are 24 in number, and in the C. S. side



truck 14, whereas in the Fox truck, in the first class that we referred to, there are only 4 separate parts. As is well known, a large number of separate parts lead to less imperfect joints that result in wear and renders maintenance expensive.

The result has been that by the various and marked improvements in the Fox truck there is a considerable lengthening in the mileage of wheels, a reduction in the wear of journals and bearings, and a lessening in the amount of lubrication necessary, and it is universally conceded that a decided and tangible economy always results from the use of Fox trucks under all classes of freight equipment, cars and locomotive tenders.

#### The Sanitation of Passenger Cars. An Interesting Comparison Between Modern and Ancient Methods.

In the course of an interesting address on the above subject by Mr. Thomas R. Crowder, M. D., Director of Sanitation and Surgery, Pullman Company, Chicago, it was stated that ten or twelve years ago, attempts to supply good air to railway cars were generally failures. The problem seemed complicated and almost hopeless. It still has its difficult points, but thanks to the enlightening research of the last ten years, it is now much simplified. We have learned what good air is: it is air that bears a proper thermic relation to the body. It must be able to absorb the body heat as rapidly as formed, without being cold enough to produce discomfort. It must be warm, but not too warm; it must have motion, but not enough to cause a chilling draught; it must be changed constantly to prevent stagnation and overheating. When these conditions, which are purely physical, are complied with, practically all other things may be left out of consideration. The chemical changes brought about by respiration are ordinarily negligible.

Due to the high wind pressure to which running trains are constantly subjected, a surprising amount of air enters them even when no special provision is made for it. I believe the quantity can always be kept adequate by the application of a simple exhaust system, as is now done on many lines. A much more difficult problem than maintaining the air supply is the proper control of heat. If the temperature is carefully regulated to between 65 and 70 degrees Fahrenheit, complaint of poor ventilation will rarely arise, even with impure air and a very small supply; but above 70 trouble comes quickly and we think there is not enough air being supplied to keep our lungs flushed out. That is not the trouble at all, for let the temperature drop to the lower sixties and the air supply remain the same and we think the amount too

large. The income and the outgo of air create motion within the car. When the temperature is too high we need more motion, hence a larger air supply, to keep the body cool; when it is too low we need less motion, or a smaller air supply, to keep the body warm. The lungs and the function of respiration have nothing to do with this; it is entirely a surface function. The practical problem of ventilation is thus seen to be one of physics, not one of chemistry. Its purpose is not so much to supply pure air as to supply air that will maintain the body's thermic balance through acting on its surface. Therein lies the reason that a fan can often be made to serve as good a purpose as an increased air supply.

With a simple exhaust system of ventilation, specific air inlets are not necessary unless cars are greatly crowded. Naturally crevices, to which may be added open sashes in the end doors, will be sufficient. For supplying artificial heat, direct radiation is better than indirect. Little cold streams of incoming air, mixing with the warmer and stiller body of air within, contribute the stimulating variation of surface environment which is so necessary to comfort and health. Only when large quantities of cold air are admitted at one place is heating of the incoming stream desirable, and this is not a good plan for ventilating railway cars. When no artificial heat is needed, as in the warm summer months, nothing can take the place of open windows, for large streams of rapidly moving air are necessary to maintain the thermic balance of the body.

In the course of the discussion that followed Dr. Crowder's address, many interesting experiences were given. Among others Mr. Paul Brays stated on the railroads of Egypt, sanitary conditions are very inadequate and unsanitary. Even on the train "De Luxe," as they call it, running from Cairo to the Great Dam at Assouan, the sanitary conditions are very inadequate and no better than the ordinary common day coaches in the United States. They have no windows in the majority of these cars, the dust flies in from the desert, and people of refined taste suffer very much discomfort from the dust and dirt, as well as the unsanitary conditions of the closets, etc.

The native people in Egypt live today as they did about 2,000 or 4,000 years ago. Diseases of the eyes are very prevalent. Every other person, and particularly the children, have something the matter with their eyes. Water is very scarce, and what is used, even in such cities as Cairo, is drawn from wells or from the Nile. I saw so many people afflicted with eye diseases, that I asked why, but could get very little satisfaction. The people of course, are very ignorant and superstitious. It seems that some time ago, a celebrated native Egyptian physician

died, who was noted for his many cures of eye disease. They buried him in the native cemetery. They have a method of burying the bodies in a shallow grave in the sand, placing a headstone at the head and one at the foot. The headstone is always somewhat higher and larger than the other. They say that the good angel presides over the head of the deceased, while the bad angel presides at the foot.

The good Egyptians, who revered this noted physician, put a stone, which contained a mortar and pestle on the headstone and filled it with dirty water. This water was supposed to contain some peculiar charm from the deceased doctor's spirit. As a result thousands of people flocked to this grave, dipped their fingers in the dirty water and rubbed it on their eyes, believing that they would become cured by the magic of the application. The result was that people with all kinds of eye diseases, who rubbed their eyes with the water, infected the water and thousands of people became affected with ophthalmia and trachoma. Finally it was brought to the attention of the Government, and they decided to remove the monument. The Egyptians said it was too bad, they had to destroy this wonderful cure for eye diseases. The filth one finds among Oriental people is in many cases beyond description. Water and soap are scarce, and what water they do get has to be drawn from infected wells, or the River Nile.

#### Keeping Out of Difficulties.

We often hear of the man who displays unusual aptness in getting out of troublesome scrapes, but few sing the praises of the man who does not get into difficulties. The man who always contrives to see that the bolts and nuts are kept tight, and that the machine or engine is properly oiled or that water does not get into the cylinders ought to receive as much consideration as the one who lets the bolts and nuts get loose and the bearings get dry, and then at the last moment works in something brilliant to save a general smash-up. The man who permits the cylinder head get knocked out and then ingeniously contrives to patch it so as to run home may be a good man, but we prefer the man who saves the cylinder head and avoids the delays that result from such an accident.

The engineer who always has water enough in his boiler; the man who goes right along doing his work and never gives trouble may not always receive praise and attention, but he is the man valued by his employers. Unfortunately there is nothing particularly brilliant in doing the right thing about every time, but that is performing first-class work which is certain to be appreciated in the long run.

# The Robinson Locomotive Superheater Growing in Favor in Great Britain and Her Colonies

The increased degree of popular favor with which the Robinson locomotive superheater is meeting not only in Great Britain, where the appliance was first used, but also in many of the other European countries and their colonies make some brief description of the details of its construction of interest. The favor with which this particular form of superheater is meeting at the present time is, of course, owing largely to the war between the central powers of Europe and the Allies. The original invention

superheating is due to the increase in the volume of superheated steam as compared with a like weight of saturated steam, and to the avoidance of cylinder condensation. It is obvious, therefore, that the higher the degree of superheat the greater will be the saving in coal and water consumption. As a rule, however, it is not considered advisable to go beyond a total steam temperature of 670 degrees Fahrenheit.

The Robinson locomotive superheater, so named because it is the invention of

for their reception, have their ends expanded direct into the header, and herein is to be found the fundamental difference between the Robinson and other kinds of smoke-tube superheaters. Flanged, or other special joints, for connecting these steam tubes to the header are thus done away with, as such joints are claimed in many cases to cause leakage. Another essential feature of the Robinson apparatus is the employment of steam jets, or draught retarders, in place of mechanical dampers, for the purpose of preventing

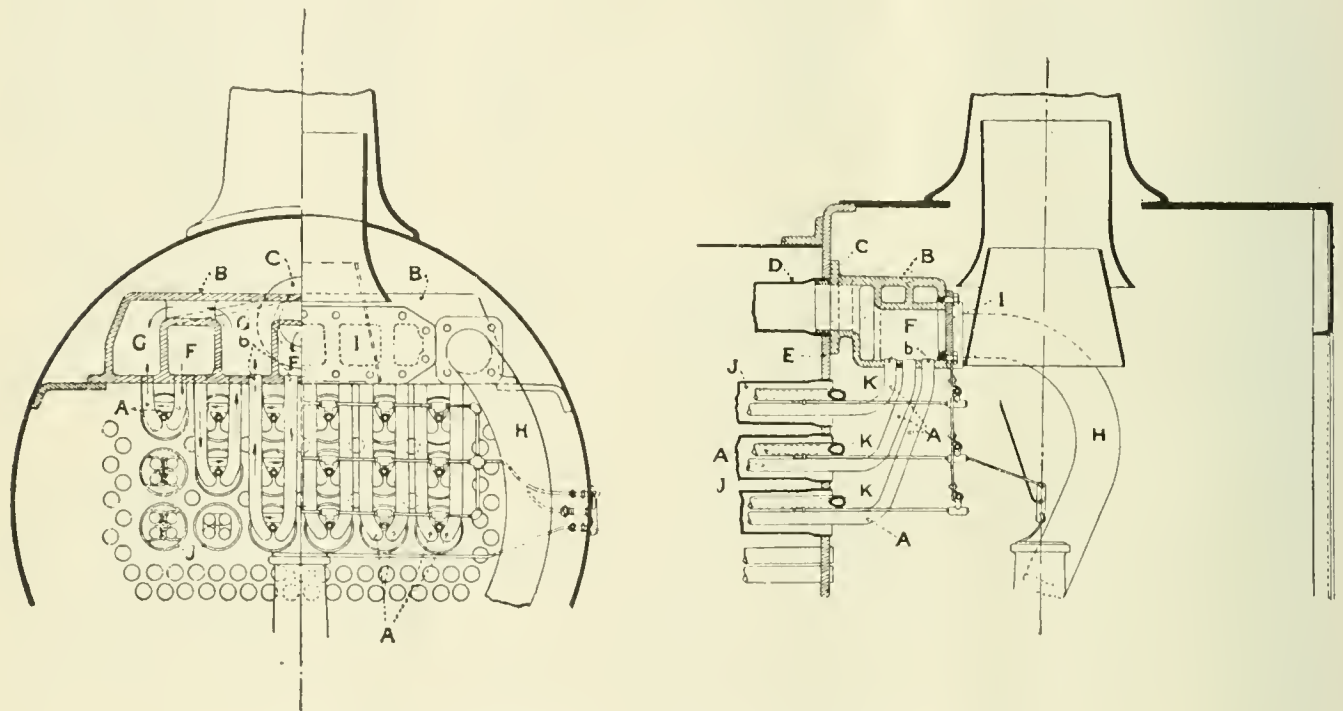

SECTIONAL VIEW OF ROBINSON LOCOMOTIVE SUPERHEATER, "A" TYPE.

being of German origin, means are being found in many parts of the world to dispense with appliances of German manufacture or invention. As to the merits or demerits of the various superheaters in use it is not necessary for us at present to make comment. The superior merits of what is known as the smoke-tube are generally acknowledged, and in these the variations are merely in matters of detail in construction. Such apparatus in nearly every case, is arranged to give a high degree of superheat. In contradistinction to superheaters of the smoke-box class, in which merely the heat remaining in the waste fire gases is utilized, smoke-tube superheaters always receive the direct heat from the fire, so that the steam circulating within the apparatus reaches a comparatively high temperature. The economy resulting from

Mr. J. C. Robinson, the chief mechanical engineer of the Great Central Railway of England, is one of the high degree smoke-tube type. Under ordinary working conditions it gives an average temperature of 650 degrees of heat, and it can, consequently, be used in conjunction with moderate boiler pressures. Two distinct arrangements of this superheater have been devised, and these, classified as "A" and "B" types, respectively, are shown in the accompanying line drawings. Type "A" has a header or steam collector, in the smoke-box, with transverse compartments and a removable front cover plate, while Type "B" has a header or steam collector with two longitudinal compartments and removable top covers. In both types the superheater steam tubes, which lie and are exposed to the heat passing through a number of boiler flues enlarged

the overheating of the superheater steam tube when the regulator is shut.

Referring to the line drawings, it will be seen that the upper part of the boiler barrel contains a series of tubes of a larger diameter than the ordinary small flues. These larger tubes, fulfill the double purpose of heating the water surrounding them, as in the case of the smaller flues, and of conveying heat to the superheater steam tubes lying inside them, since the fire gases pass directly through the smoke-tubes. The superheater steam tubes consist of separate elements, and each of the large smoke-tubes contains one of these elements. Each element comprises a four-fold length of tubing connected at the bends by U pieces. One end of this tubing is in communication with a saturated steam compartment of the header in the smoke-box, while the other end leads to

a superheated steam compartment. All the elements are similarly arranged, the header being divided into a suitable number of compartments accordingly. The number of elements employed varies with the size of the boiler, and the degree of superheat required, but it corresponds in all cases with the number of smoke-tubes. The four-fold length of superheater steam tubing extends backwards in each smoke-tube to within a short distance of the fire-box tube-plate, where it is in a position to receive the full benefit of the heat generated by the fuel on the grate.

Such, briefly, is the general principle underlying all smoke-tube superheaters. There are, however, often considerable differences in details, such as the arrangement of the headers, and the method of securing the two ends of each superheater

element in the large flue opening, where it is usually held centrally in place by attachments for that particular purpose. Of course, the end of the flue could readily be cut off and an additional piece welded on to meet the requirements of the situation, but even this operation would have its drawbacks, not only in the time required to withdraw the flue from its position in order that the operation might be properly accomplished, but also in the inevitable closing of the flue in its inner area, thereby to some extent lessening the circulation of the steam flowing through the flue in its return to the header. Probably some of our British correspondents may enlighten us in regard to the prevailing method of overcoming this difficulty, for difficulty it certainly is in contrast to the ball joint used

ance has reached in the United States is the best in the world.

**Methods of Treating Water for Locomotive Boilers.**

The above is the subject of an able paper read by Mr. L. F. Wilson before the members of the Cincinnati Railway Club last month, wherein the speaker stated that there are three ways in which trouble in boilers come—in incrustation, in corrosion, or foaming—sometimes all three together, but luckily not much scale in water which has a foaming tendency, or foaming in water which has a large percentage of incrustating solids. Sulphates cause hard scale, the carbonates cause a mud precipitate and alkali salts cause foaming. Low pressures do not have serious scale troubles. Sulphates

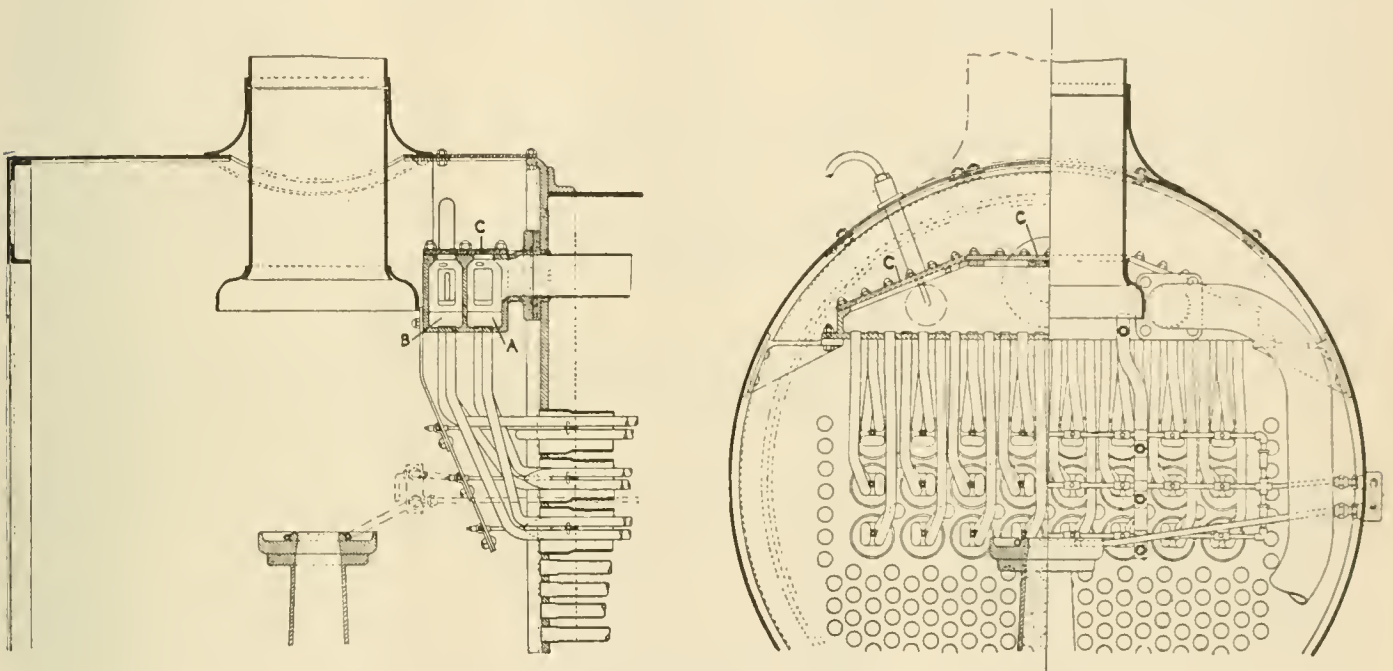

SECTIONAL VIEW OF ROBINSON LOCOMOTIVE SUPERHEATER, "B" TYPE.

element to the smoke-box header. These, as already stated, are attached to the header in the same manner as ordinary flues in the flue sheet, and can be easily disconnected and can afterwards be re-expanded into the header.

In collecting the data in regard to the Robinson superheater, which we have done from the best British authorities available, and which has been done primarily at the request of a number of correspondents in the British colonies, we have so far been unable to find any exact account of how the flues are removed from the header and again reattached without the loss of material. It may be readily imagined that the bead inside the header may be easily cut off and the flue pressed out of the header, but even this operation involves a loss of some material which would necessitate a drawing upwards of the flue which would affect its proper cen-

tral position in the large flue opening, where it is usually held centrally in place by attachments for that particular purpose. Of course, the end of the flue could readily be cut off and an additional piece welded on to meet the requirements of the situation, but even this operation would have its drawbacks, not only in the time required to withdraw the flue from its position in order that the operation might be properly accomplished, but also in the inevitable closing of the flue in its inner area, thereby to some extent lessening the circulation of the steam flowing through the flue in its return to the header. Probably some of our British correspondents may enlighten us in regard to the prevailing method of overcoming this difficulty, for difficulty it certainly is in contrast to the ball joint used

in the more popular forms of the superheater attachments, and which we described at some length in the May issue of RAILWAY AND LOCOMOTIVE ENGINEERING. During a recent visit to the British Isles we had opportunities to observe the working of a number of locomotives equipped with the Robinson superheater, but as our time was limited we did not have the opportunity of observing the repair work on the leaky flue ends of the superheater, but we could see at a glance that they were not all as tight as they should be, and it is our hope that some correspondent will enlighten us so that we may be in a position to describe fully the most approved methods of repairing the shortcomings of the appliance to the edification of our readers generally and our British colonial readers particularly. Meanwhile, as we have already stated, the degree of perfection to which the appli-

precipitate at 60 or 70 lbs. pressure. Carbonates precipitate at a boiling temperature, 212 lbs. Corrosion goes with the sulphate scale. The use of soda-ash is of long standing, but it will throw down the incrustating solids only. The great trouble is that many locomotives must take on a variety of waters during their run and different remedies are necessary to meet the varying conditions. An anti-foaming compound should be mixed with the water in the tender tanks and should be carefully given out the same as valve oil. The danger is in using too much. There need now be no mystery about the use of compounds. The varying waters should be carefully analyzed by experts and the proper quantities of the necessary solvents used. Good business policy directs that with the assistance of reliable records good, consistent, economical service can be performed.

# Items of Personal Interest

Mr. R. J. Watters has been appointed assistant general air brake inspector of the Northern Pacific, succeeding Mr. D. A. McMillan.

Mr. John R. Sexton has been appointed division engineer of the Erie, with office at Meadville, Pa., succeeding Mr. C. W. Bucholtz, promoted.

Mr. F. Williams has been appointed general foreman of the locomotive and car department of the Wellsville & Buffalo, with office at Blasdell, N. Y.

Mr. N. B. Corbett has been appointed shop superintendent of the Missouri, Kansas & Texas, at Denison, Tex., succeeding Mr. B. C. Nicholson.

Mr. F. C. Wager, formerly master mechanic of the Spokane, Portland & Seattle, has transferred his office from Portland, Ore., to Vancouver, Wash.

Mr. James E. Martin has been appointed roundhouse foreman of the Great Northern, with office at Judith Gap, Mont., succeeding Mr. S. D. Kidder.

Mr. George W. Wenz, formerly assistant purchasing agent of the Gould Coupler Company at Depew, N. Y., has been appointed purchasing agent of the company.

Mr. T. H. Hamilton has been appointed district master mechanic, districts 1, 3 and 4, Ontario division of the Canadian Pacific, with office at Toronto, Ont.

Mr. Samuel Murray has been appointed chief engineer of the Union Pacific system, and Oregon-Washington & Navigation Company, with headquarters at Portland, Ore.

Mr. Frank C. Worbs has been appointed assistant engineer of the Wheeling & Lake Erie, with headquarters at Cleveland, Ohio, succeeding Mr. E. U. Smith.

Mr. J. H. Gaston has been appointed master mechanic of the Atlanta & West Point, and Western railway of Alabama, with office at Montgomery, Ala., succeeding Mr. O. H. Attridge.

Mr. F. W. Sadlier, formerly shop foreman of the Canadian Pacific at Revelstoke, B. C., has been appointed district master mechanic on the same road at Fort William, Ont.

Mr. A. H. McCowan, supervisor of car work of the Canadian Northern lines west of Port Arthur, Ont., has had his authority extended over the eastern lines of the same road.

Mr. M. I. Fox, assistant signal engineer of the Chicago, Burlington & Quincy, has become associated with the signal department of the Railroad Supply Company, Chicago, Ill.

Mr. A. W. Martin has been appointed superintendent of shops of the

Cleveland, Cincinnati, Chicago & St. Louis, at Beech Grove, Ind., succeeding Mr. R. J. Williams, resigned.

Mr. A. Brown, formerly district master mechanic of the Canadian Pacific at Winnipeg, has been appointed district master mechanic, district No. 1, British Columbia division; at Revelstoke, B. C.

Mr. A. G. Kingan, formerly superintendent of locomotive operation on the Seaboard Air Line has become chief consultant for the Powdered Coal Engineering & Equipment Company, Chicago, Ill.

Mr. E. T. Sawyer formerly connected with the Commercial Acetylene Railway Light & Signal Company has resigned to accept a position as sales manager with the Edison Storage Battery Company.

Mr. F. A. Martin has been appointed roundhouse foreman of the Rock Island at Rock Island, Ill., and Mr. J. G. Kehoe has been appointed night roundhouse foreman at the same place.

Mr. W. E. Greenwood has been appointed manager of the railway sales and fuel oil department of the Texas Company, succeeding Mr. L. F. Jordan, with offices at 17 Battery Place, New York.

Mr. A. G. Williams, formerly assistant master mechanic of the Pennsylvania Lines, West, has been appointed assistant engineer of motive power on the same road, succeeding Mr. L. B. Jones, transferred.

Mr. D. W. Sinclair, formerly foreman of the Missouri, Oklahoma & Gulf at Allen, Okla., has been appointed master mechanic on the same road, with office at Denison, Tex., succeeding Mr. J. Greiner.

Mr. George Hodges, chairman of the Committee on Relations Between Railroads of the American Railway Association, has been elected chairman of the Committee on Legal and Traffic Relations.

Mr. G. C. Gibson, formerly locomotive foreman of the Canadian Pacific at Strathcona, Alta., has been appointed locomotive foreman at Saskatoon, Sask., succeeding Mr. C. A. Perry, transferred.

Mr. R. F. Finley has been appointed superintendent of telegraph of the New York Central lines west of Buffalo, the Lake Erie & Western, and the Western Union Telegraph Company, with offices at Cleveland, Ohio.

Mr. E. C. Keenan, formerly general superintendent of telegraph of the New York Central lines west of Buffalo, at Chicago, has been appointed general superintendent of telegraph, with offices at New York.

Mr. H. L. Breckinridge, formerly purchasing agent of the American

Locomotive Company at Montreal, Que., has been appointed purchasing agent of the Lima Locomotive Corporation, Lima, Ohio.

Mr. G. A. Harwood, formerly chief engineer of electric zone improvement of the New York Central at New York, has been appointed engineering assistant to the vice-president, in charge of operation, with offices at New York.

Mr. J. L. Adams, formerly sales representative of the Cambria Steel Company, at Cincinnati, Ohio, has been appointed manager of sales of the Cambria Steel Company, the Midvale Steel Company and Worth Brothers Company.

Mr. O. H. Attridge, formerly master mechanic of the Atlanta & West Point, and the Western Railway of Alabama, has been appointed master mechanic of the Georgia railroad, with office at Augusta, Ga., succeeding Mr. J. H. Gaston.

Mr. M. F. Crawmer has been chosen as secretary of the American Railway Tool Firemen's Association, with office at 124 N. Clinton St., Chicago, Ill. He will have charge of all exhibits at the convention of the Association to be held at Hotel Sherman, Chicago, August 24-26.

Mr. Thomas Lewis, formerly master mechanic of the Auburn division of the Lehigh Valley at Auburn, N. Y., has been appointed general boiler inspector for the system, with office at Sayre, Pa., and Mr. M. Jefferson, formerly assistant master mechanic on the same road at Easton, Pa., succeeds Mr. Lewis.

Mr. James Fitzmorris, formerly master mechanic of the Chicago Junction Railway, has been appointed superintendent of motive power of the same road, with office at Chicago, and Mr. P. A. Campbell, formerly chief clerk in the machinery department has been appointed assistant superintendent of motive power with office also at Chicago.

Mr. John Dickson, formerly master mechanic of the Spokane, Portland & Seattle, the Oregon Trunk, the Pacific & Eastern, the Oregon Electric, and the United Railways and the Spokane & Inland Empire, has been promoted to superintendent of motive power, with headquarters at Portland, Ore., the position of general master mechanic having been abolished.

Mr. F. T. Huston, formerly assistant master mechanic of the Pennsylvania Lines, West, at Fort Wayne, Ind., has been appointed general car inspector of the northwest system of the Pennsylvania Lines, West, succeeding Mr. O. J. Parks, resigned, and Mr. Walter Hamilton has been appointed assistant master mechanic of the Pennsylvania Lines, West, at Fort Wayne, succeeding Mr. Huston.



"Some folks," remarked Old Jerry, as he waved aside the salesman's proffered cigar, "just take naturally to usin' any kind of tobacco.

"Like one of the boys I once knew who tried to get along without the little red tin of Dixon's Flake Graphite. He didn't seem to think that 'flake' meant any particular kind of graphite and 'Dixon's' any particular kind of flake.

"I never saw such a disgusted one as Pete was," chuckled Old Jerry, "after his graphite had balled up once or twice in his cylinders, and if it wasn't because the rest of us was usin' flake graphite he would have sworn up and down right there that graphite was the most durned fool stuff to use as a lubricant.

"'Pete,' I says, pullin' out my old Dixon Ad and grin-nin' at the boys, 'it says here: 'Write for 'Graphite Products for the Railroad and Sample No. 69-C.' '"

"'You're right, Jerry,' he says."

**Joseph Dixon Crucible Company**

Established 1827

39-C **JERSEY CITY, N. J.**

#### Railroad Equipment Notes.

The Texas & Pacific is making inquiries for eight Santa Fe locomotives.

The Chesapeake & Ohio, according to report, contemplates the purchase of 1,500 cars.

The Baltimore & Ohio has ordered 1,000 box cars from the Haskell & Barker Car Company.

The McKeesport Connecting has ordered 2 six-wheel locomotives from the Baldwin Locomotive Works.

The Havana Central has ordered 300 flat, 200 box and 10 hopper cars from the Pressed Steel Car Company.

The Southern Railway has placed an additional order with the Lenoir Car Works for 1,000 30-ton box cars.

The French government is reported as having ordered 3,000 box cars from the Canadian Car & Foundry Company.

The St. Louis & San Francisco, according to report, contemplates construction of a 35-stall roundhouse, at Tulsa, Okla.

The Canadian Government Railways have ordered 500 additional box cars from the Canadian Car & Foundry Company.

The Lehigh Valley has ordered 30 Pacific type locomotives and 40 Santa Fe type locomotives from the Baldwin Locomotive Works.

The Seaboard Air Line, which has just ordered 5 Mountain type locomotives, is reported as contemplating the purchase of 10 Mallet type engines.

The Russian government is reported as closing contracts with American mills for 350,000 tons of rails besides large quantities of other steel commodities.

The New York, Chicago & St. Louis has placed an order with the Pressed Steel Car Company for the repair of 500 cars. Steel center sills will be applied.

The Havana Central has ordered from the Pressed Steel Car Company 200 box cars of 30 tons capacity, 200 platform cars of 20 tons capacity and 10 hopper cars.

The Chicago Great Western, it is said, has placed a contract at Chicago for 19,000 rail anchors and tie plates for its eastern division and for 11,000 tie plates for the northern division.

The Boston & Albany will convert 12 Consolidation type locomotives to switching locomotives in its West Springfield, Mass., shops. The engines will also be equipped with superheaters.

The Pullman Company has received three orders for private cars; one from the Canadian Pacific, one from the Delaware, Lackawanna & Western and one from J. B. Duke, of New York.

The St. Louis, Iron Mountain & Southern will shortly commence work on a new depot at Bismark, Mo., to cost \$10,000. The company will also erect a roundhouse and coal chute there.

The New York, New Haven & Hartford reported as negotiating with the Westinghouse Electric & Manufacturing Co. for electric locomotives, is understood to have closed contract for 100 locomotives.

The Pressed Steel Car Company is reported building 1,500 cars for the French government. France is also said to have ordered 2,000 additional cars from the Eastern Car Company, New Glasgow, N. S.

The United Railways of Havana have ordered 3 Consolidation type locomotives from the American Locomotive Co. Cylinders will be 20 by 26 inches, driving wheels 50 inches, total weight in working order 159,000 pounds.

Recent order of the Chesapeake & Ohio to the American Locomotive Company calls for 25 Mallet type freight locomotives with cylinders 22 and 35 by 32 inches, driving wheels 56 inches in diameter, and total weight in working order 435,000 pounds.

The Pennsylvania Lines West will install an interlocking plant at its crossing with the Cincinnati, Hamilton & Dayton and the Lake Erie & Western at Lima, Ohio. The latter roads have completed a short stretch of double-track for joint use at this point.

Bids are being received by the M. J. Hursen Company, Globe building, Seattle, Wash., for the steel and iron work and the sheet metal involved in the construction of the \$40,000 roundhouse for the Oregon-Washington Railroad & Navigation Company at La Grande, Ore.

Block signals now being installed on the San Pedro, Los Angeles & Salt Lake, will cost \$400,000. Direct current automatic interlocking signals of the very latest design will be set in place between Los Angeles and Riverside, Cal.; Salt Lake City and Lyndyl, Utah; and Modena to Rox, Nevada, aggregating 280 miles.

### Canadian Railway Development.

During the last five years the railway mileage of Canada has increased by 10,852 miles, of which 4,788 miles were brought to completion in 1915. The total mileage is now 35,582, and Canada stands fourth among the nations of the world, being surpassed only by United States, Russia, and Germany. The approximate cost of the lines built since 1910 was \$856,464,000. Only 1,600 miles of new line were under contract on June 30, 1915, as compared with a much larger mileage two years ago, and not a single new line has been started since 1914. The lull in construction work will afford time for the development of the 10,000 miles of railroad put into operation since 1910, for new mileage is invariably low in density of traffic for some years and nearly 62 per cent. of the additional lines are located in the comparatively undeveloped country west of Lake Superior.

### Railroad Criticism.

When the Pennsylvania railroad invited criticism from its patrons it did a notable thing, if it were nothing else than providing a safety-valve for the man with a grouch. The results show how amazingly selfish we all are, how deficient in imagination, how incapable of putting ourselves in the place of another, but yet in the thick atmosphere of petty fault-finding there are some grains of common sense, which the company are quick to utilize and provide improvement. The early June issue of *Information* for employees and the public makes good reading. It shows how anxious the company is to improve the service, how long suffering the employees are, and how amazingly stupid the general public is. The latter is not beyond hope, however, and a perusal of such of the complaints as are published in the issue we refer to, will be helpful in letting us see ourselves as others see us. Other railroads should follow the strong example, and get in closer touch with their patrons.

### The Output.

The second year has begun of the publication devoted to increasing production in manufacturing and other industries by the Cooper-Hewitt Electric Company, Hoboken, N. J. It furnishes interesting data in regard to the increased amount of work that can be done where the company's electric lighting system is installed. The figures are amazing. It beats daylight, especially such daylight as we have been having in June in the Eastern States. The dwellers in darkness are certainly slow. Those who rejoice in the glow of the Cooper-Hewitt illuminants have speed. There may be some who love the darkness better than the light, but they are behind the age. Seeing is believing, but in mechanism it is improved

producing. The believers in efficiency should come out of their holes and see a great light, and all interested should send for a copy of the *Output* and have their eyes opened.

### Improvements on the Salt Lake Route

The Salt Lake Route has begun the expenditure of 1½ million dollars in improvements. These betterments included in the 1916 budget prepared by General Manager H. C. Nutt and approved by ex-Senator Clark and Judge R. S. Lovett, provide for the spending of \$547,000 for new rail of 90-lb. section, \$260,000 in bridges, and \$511,000 in miscellaneous improvements. Several hundred men will be employed to carry out the new work, and increased activity will be displayed along the entire system. A large part of the material used will be bought in Los Angeles. The new bridges will be of steel with concrete foundations.

Increasing traffic over the short cut to Los Angeles from the inter-mountain States, in summer as well as in winter, justifies the extra investments in the opinion of the management.

### A Tool Breaker.

Sad experience makes us resentful when we see such tools as taps, dies and reamers broken by reckless ignorant workmen, who have no right to be called mechanics. During a recent trip we watched a person using a reamer upon a locomotive frame. Every half turn he would pull the wrench off, and hit the top of the reamer a hard tap, spit over his shoulder and turn the reamer again. The tool was often forced in so tight that the person could not turn it, and the head of the wrench looked as if it had been in a dog fight and come out worsted.

We could not help thinking that the foreman whose duty it was to supervise the work done by the person, performed less than his duty.

### Figuring Train Speed.

Some simple rules are very useful to locomotive engineers. For instance: Take  $\frac{2}{11}$  of a locomotive wheel diameter in inches, and the result is a number which represents in seconds the period during which the revolutions of the wheel equal in number the speed of the train in miles per hour. Example: A locomotive wheel is 55 inches diameter. If you observe in  $\frac{2}{11} \times 55 = 10$  seconds that it makes 24 revolutions, the speed is 24 miles per hour.

A man must have either great men or great objects before him, otherwise his powers degenerate, as the magnet's does when it has lain a long time without being turned towards the right corners of the world.

# GOLD Car Heating & Lighting Company

Manufacturers of

ELECTRIC,  
STEAM AND  
HOT WATER  
HEATING  
APPARATUS  
FOR RAILWAY CARS  
VENTILATORS  
FOR PASSENGER  
AND REFRIGER-  
ATOR CARS  
ACETYLENE SYSTEM  
OF CAR LIGHTING

Send for circular of our combination PRESSURE AND VAPOR SYSTEM OF CAR HEATING, which system automatically maintains about the same temperature in the car regardless of the outside weather conditions.

Main Office, Whitehall Building  
17 BATTERY PLACE  
NEW YORK

# Hydraulic

**Riveters Fixed and Portable  
Punches, Shears,  
Presses, Lifts, Cranes  
and Accumulators.**

**Matthews' Fire Hydrants,  
Eddy Valves  
Valve Indicator Posts.**

**The Camden High-Pressure Valves.**

## Cast Iron Pipe

**R. D. Wood & Company**

**Engineers, Iron  
Founders, Machinists.**

**100 Chestnut St., Philadelphia, Pa.**

## Nichols Transfer Tables Turntable Tractors

**GEO. P. NICHOLS & BRO.  
1090 Old Colony Bldg. CHICAGO**

## For Testing and Washing Locomotive Boilers

USE THE

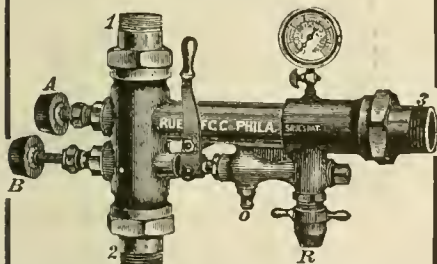

## Rue Boiler Washer and Tester

SEND FOR CATALOGUE

**Rue Manufacturing Co.  
228 Cherry Street Philadelphia, Pa.**

Manufacturers of Injectors, Ejectors,  
Boiler Washers and Testers, Boiler Checks,  
Check Valves.



## ASHTON POP VALVES AND GAGES

The Quality Goods That Last

**The Ashton Valve Co.  
271 Franklin Street, Boston, Mass.  
No. 174 Market St., Chicago, Ill.**

# Books, Bulletins, Catalogues, Etc.

THE MECHANICAL ENGINEERS' POCKET-BOOK. Lionel S. Marks, Editor in Chief. Published by the McGraw-Hill Publishing Company, New York.

This book covers the entire field of mechanical engineering, and as a reference book, both to the practicing engineer and the student, it is a very notable contribution to the engineering literature of our time. Fifty specialists have contributed to its pages, all of them recognized as among the leading authorities on their chosen subjects. The result is that much of the matter is not only new, but is also in a marked degree necessary. This is especially so in the important addition of a vast number of constants that have hitherto not been available in any single work on engineering. As may be readily imagined, we cannot begin to enumerate the wide range of subjects. In those with which we are familiar we can certify that the information is not only reliable, but it is up to the present hour. The first 860 pages are devoted to the more theoretical topics, and the last 960 pages to the statement and discussion of current practice. The alphabetical classification is perfect, while the indexing is such that engineers will rise up and call the painstaking editor blessed. The book cannot fail to meet the marked popular favor which it deserves. The price is five dollars.

COMPLETE TIME CARD AND RULE EXAMINATION FOR ENGINEERS. By Frederick J. Prior, Hinsdale, Ill.

The book of rules of the Santa Fe system has furnished the basis for the examination questions in this work. They are arranged in the same order, but they are equally applicable to the Book of Rules examination of any other railroad, as they are all based upon the Standard Code of the American Railway Association. The book is in very convenient form, 6 by 4¼ ins., substantially bound in stiff covers. The letterpress is excellent and the data are reliable. There are 27 sections in the arrangement of the book, making reference to any subject easy. Price \$1.50.

### Long Island Safety Bulletins.

Automobilists should guard their sanity, if they have such a thing about them, just as a sensible person guards health. The Long Island Railroad Company is covering the entire island with notes of warning. The placards set forth that in 1915 82 automobiles ploughed through railroad crossing gates which had been lowered to protect the public against approaching trains. Among other disasters occurring from reckless driving last year, a crossing watchman was struck by an

automobile, the driver of which he was warning, thrown sixty feet and then deliberately run over and killed by the same machine. The watchman was buried, and the driver got three months in a State institution—only three months! So the Long Island Railroad has not the support of the Judiciary that it should have. But it keeps up the good work just the same, and the effect is of the most encouraging kind. Indications are that automobilists are beginning to give a little thought to the saving of lives as well as the saving of a few seconds in their mad journeys to nowhere.

### Foaming.

The Bird-Archer Company, 90 West street, New York, have issued an interesting booklet advising engineers that if the engine is foaming and losing time, and cannot pull the tonnage, read the booklet, and procure the remedy. It is claimed that the chemists of the Bird-Archer Company have produced a chemical compound called "Anti-Foam" that will prevent the water foaming in the boiler, and furnish dry steam. Some men are prejudiced against foaming compounds, and do not realize fully that we live in an age of progress. Some men expect too much. The compound produced by the enterprising company is not guaranteed to keep boilers clean or remove scale, but qualified authorities agree that it will prevent foaming. The booklet furnishes details as to the exact amount of compound to be used, and the proper use of the blow-off cock. Aggravated cases are referred to, and the company's chemists are prepared to tackle the dirtiest boiler in the world, and all that is asked is a fair trial. Copies of the booklet may be had on application to the company's New York office.

### Staybolts.

The Flannery Bolt Company begins the new volume with their midsummer number giving a report of the Master Boiler Makers' convention held at Cleveland, Ohio, last month, which is a model of its kind, and which many trade journals would do well to imitate in point of condensation. As may be expected the admirable display made of the company's products comes in for some finely descriptive writing, a fine feature of which is the presentation briefly and clearly of the proper method of installing the staybolts. Coincidentally we publish this month in our correspondence department a letter from the worthy president of the company, Mr. B. E. D. Stafford, in answer to one of our correspondents setting forth very plainly the approved meth-

od of installation. It might be added that the methods are not arbitrary, the company is always pleased to have interchange of ideas from men of experience. Copies of the company's monthly publications may be had on application to the main office, Pittsburgh, Pa.

**Department of Labor Special Bulletin.**

The State of New York department of labor Special Bulletin No. 77, issued under the direction of the Industrial Commission is devoted to industrial accident prevention, and a fine feature of the publication is the accident experience furnished by the American Locomotive Company's Schenectady plant, showing that the reduction of accidents occasioning loss of time to locomotives in actual service has been reduced in a remarkable degree. The average per month for the last three years is shown, from which it appears that the reduction from 1913 to 1914 was 45 per cent., from 1914 to 1915, 30 per cent., and from 1913 to 1915, 62 per cent. Although the accident records of only a few employers are charted, enough is shown to demonstrate that the progress in the prevention of accidents is very great. It is not possible to compare the records of one establishment with the record of another, because their safety campaigns did not all begin at the same time. Among those showing a high percentage of increased safety are the Lackawanna Steel Company from 1913 to 1915, 44 per cent.; and the General Electric Company during the same period, 34 per cent. The results all along the line show less suffering, less compensation cost and better output. Copies of the bulletin will be supplied on request to the New York State Industrial Commission, Albany, N. Y.

**The Safety Heating & Lighting News.**

In their June issue the Safety Car Heating & Lighting Company publish a full description of the "Safety First Special" train drawn by two new locomotives of the largest type used in the passenger service of the Baltimore & Ohio Railroad. The train embodies the late developments in railroad equipment, and is said to be the finest of its kind ever operated in the country. It represents an investment of \$150,000, independent of the cost to the government for fitting it out in order to bring the people of the United States in touch with the varied activities of the federal service in protecting lives and health. Safety Car Heating & Lighting Company's axle driven electric lighting system and safety car lighting fixtures are used on the cars. The train is being exhibited in various cities throughout the country, and is open free for public inspection. The exhibit of the United States army is particularly interesting, and is arranged to show the

equipment of the soldiers in the field of battle and general service.

**The Spirit of Caution.**

The Conference Board on Safety and Sanitation are issuing a valuable periodical under the above title, representing organized co-operation between industrial managers, engineers and superintendents, located in every section of the United States and Canada. Their experience in safeguarding the workmen constitute much information which the experts of the conference board utilize in studying industrial hazards, and in developing practicable means to counteract or eliminate them. All protective devices or methods are given impartial trials under varying conditions of service, and if the results warrant, are then recommended to employers for adoption in their plants. In this way the results are highly beneficial, and sometimes such devices are manufactured for the board and sold at cost price to all employers whether members of the co-operating association or not.

*Statement of the ownership, management, etc., required by the act of Congress of August 24, 1912, of RAILWAY AND LOCOMOTIVE ENGINEERING, published monthly at New York, N. Y., for April 1, 1916.*  
 State of New York }  
 County of New York } ss.

Before me, a Notary Public in and for the State and county aforesaid, personally appeared Harry A. Kenney, who, having been duly sworn according to law, deposes and says that he is the Business Manager of the RAILWAY AND LOCOMOTIVE ENGINEERING, and that the following is, to the best of his knowledge and belief, a true statement of the ownership, management, etc., of the aforesaid publication, required by the Act of August 24, 1912, embodied in section 443, Postal Laws and Regulations, printed on the reverse of this form, to wit:

1. That the names and addresses of the publisher, editor, managing editor and business managers are: Publisher, Angus Sinclair Co., Inc., 114 Liberty St., New York, N. Y.; Editor, Angus Sinclair, 114 Liberty St., New York, N. Y.; Managing Editor, James Kennedy, 114 Liberty St., New York, N. Y.; Business Manager, Harry A. Kenney, 114 Liberty St., New York, N. Y.

2. That the owners are: Angus Sinclair Co., 114 Liberty St., New York, N. Y. Stockholders owning 1 per cent. of the total amount of stock: Angus Sinclair, 114 Liberty St., New York, N. Y.; James Kennedy, 114 Liberty St., New York, N. Y.; Harry A. Kenney, 114 Liberty St., New York, N. Y.; Mrs. O. J. Schanbacher, 40 Heddon Terrace, Newark, N. J.

3. That the known bondholders, mortgagees and other security holders owning or holding 1 per cent. or more of the total amount of bonds, mortgages, or other securities are: None.

4. That the two paragraphs next above, giving the names of the owners, stockholders, and security holders, if any, contain not only the list of stockholders and security holders as they appear upon the books of the Company, but also, in cases where the stockholder or security holder appears upon the books of the company as trustee or in any other fiduciary relation, the name of the person or corporation for whom such trustee is acting, is given; also that the said two paragraphs contain statements embracing affiant's full knowledge and belief as to the circumstances and conditions under which stockholders and security holders who do not appear upon the books of the company as trustees, hold stock and securities in a capacity other than that of a bona fide owner; and that this affiant has no reason to believe that any other person, association or corporation has any interest direct or indirect in the said stock, bonds or other securities than as so stated by him.

HARRY A. KENNEY,  
 Business Manager,  
 Sworn to and subscribed before me this  
 twenty-second day of March, 1916.  
 OLIVER R. GRANT,  
 Notary Public, Bronx County, Certificate filed  
 New York County No. 43.  
 My commission expires March 30, 1917.

**STEEL STAMPS**  
**INSPECTORS HAMMERS**  
 Hand Cut STEEL LETTERS & FIGURES  
 LATHE TOOLS, TIME CHECKS,  
 Noble & Westbrook Mfg. Co.  
 9 ASYLUM ST. HARTFORD, CONN.

**Locomotive Engine Running and Management**

By ANGUS SINCLAIR

This popular book has been a **RELIABLE REFERENCE** and comfortable unailing **POCKET EDITION.**

PRICE, \$2.00

**ANGUS SINCLAIR CO.**  
 114 Liberty St., New York

**ROYLE-NATIONAL**  
 ELECTRIC HEADLIGHTS  
 CHICAGO

**THE ARMSTRONG IMPROVED PACKER RATCHET DRILLS**  
 Are ALL STEEL and Hardened All Over  
 Will outwear two of the soft kind. We make all kinds—all sizes.  
 Do you want a catalog?  
**ARMSTRONG BROS. TOOL CO.**  
 "The Tool Holder People."  
 112 N. FRANCISCO AVE., CHICAGO, ILL.

ENAMELED IRON FLUSH OR DRY CLOSETS  
**DUNER CAR CLOSETS**  
**DUNER CO.**  
 118 S. CLINTON ST., CHICAGO

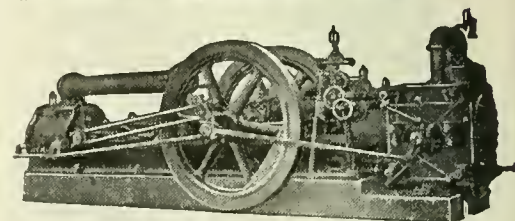

**The Norwalk Iron Works Co.**  
 SOUTH NORWALK, CONN.  
 Makers of Air and Gas Compressors  
 For All Purposes  
 Send for Catalog



# Railway AND Locomotive Engineering

A Practical Journal of Motive Power, Rolling Stock and Appliances

Vol. XXIX.

114 Liberty Street, New York, August, 1916.

No. 8

## Origin and Manufacture of Oxy-Acetylene Details of Means and Methods for Its Use

As early as 1862 experiments had been made with a mixture of charcoal, zinc and calcium, which when heated to a high temperature would decompose water and produce gas known as acetylene. The introduction of the electric furnace made

in water produced a gas which, when ignited, burns with a bright flame accompanied with much soot. The solid mass is known as calcium carbide and the gas is now known as acetylene. Calcium carbide is simply a mixture of carbon and

carbide will produce about five and one-half cubic feet of acetylene. The substance known as carbide is now produced by melting lime and carbon by the action of an electric furnace with a heat of over 6,000 degrees Fah. Carbon in the com-

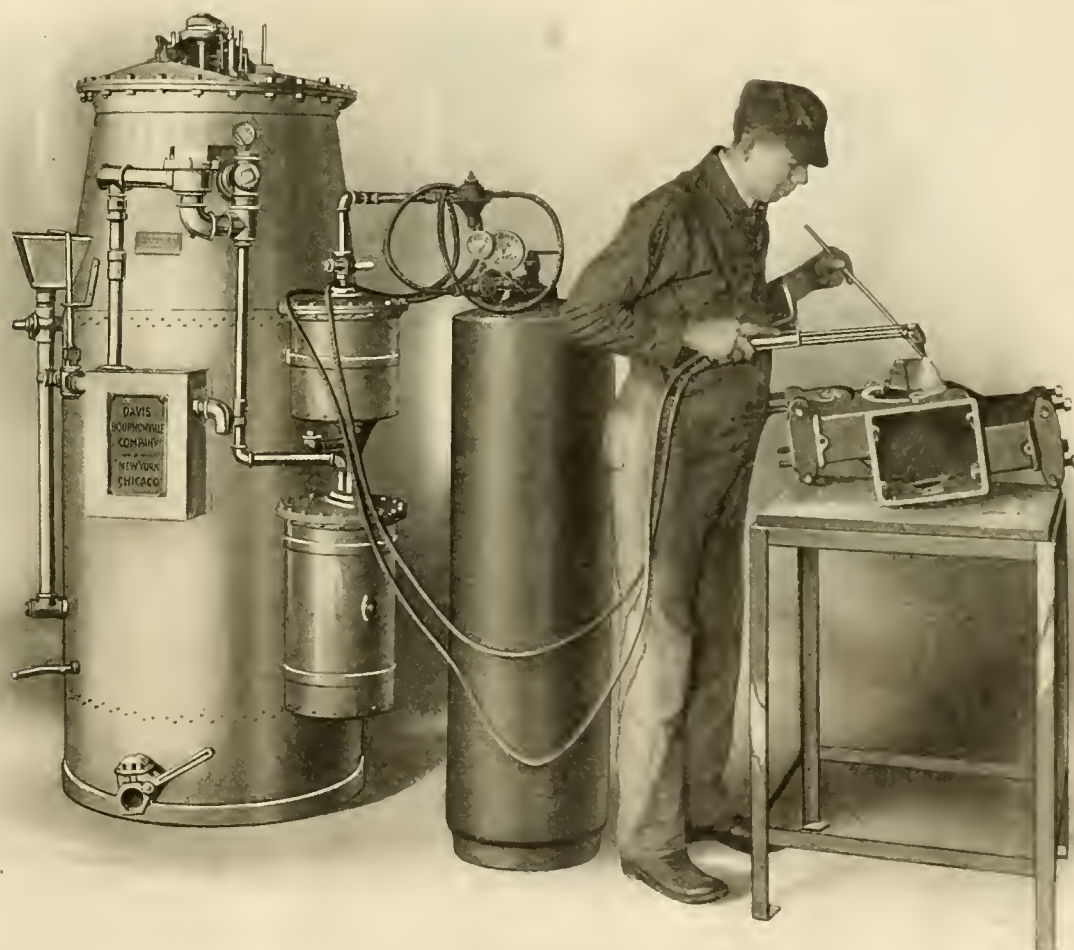

100-LB. GENERATOR, WELDING OUTFIT AND OPERATOR.

the production of calcium carbide a commercial possibility. In the atmosphere of American enterprise advances were made, and electric furnaces acting upon a mixture of lime and coal tar produced a molten mass which became hard and brittle when cooled. This when immersed

calcium. It resembles a coarse kind of stone and will burn only when heated with oxygen. To preserve calcium carbide it must be protected from the air, the moisture in the atmosphere gradually disintegrating the mass, leaving a remnant of slaked lime. One pound pure

monest form is the material used in arc light electrodes, and this substance, as well as lime, stands extremely high temperatures, and it is, as we have already stated, by the very high temperature attainable by the electric furnace that causes the fusion of the substances and makes

possible the formation of the carbide.

Coming to the exact properties of acetylene, it is composed of twenty-four parts of carbon and two parts of hydrogen in weight. This percentage of carbon is the highest known to exist in a gaseous form. Carbon may be said to be the basic form of all matter that is combustible and is present in all fuels. In fuel gases acetylene is the most powerful, and hence its possibility to the development of the hottest flame when harnessed in a torch. Its ignition point is about 900 degrees Fah., coal gas being about 1,100 degrees. The degree of purity to which it has attained during recent years by the careful

mospheres renders acetylene possible of self-ignition, and the danger increases in a ratio to the pressure. With the presence of acetone, acetylene loses this dangerous quality, and can be safely handled, the only remaining danger being that as the acetylene is dissolved the acetone increases its volume, and as the gas is drawn out of a closed tank the space left is full of free acetylene. This new danger is removed by filling the tank with some porous substance, asbestos being the most common in general practice.

The acetylene gas then dissolved and protected is forced into portable containers at a pressure of 150 pounds per square inch, for the use of consumers. The quantity remaining enclosed may be readily ascertained by knowing the weight of the empty cylinder and noting the difference between that amount and the weight of the cylinder containing the gas, one pound of which occupies about 14½ cubic feet.

The complete equipment of present day practice includes besides the acetylene

varying sizes of tips, the larger sizes being necessary according to the increase in the size of the metal. The tables issued by the Davis-Bournonville Company, being based on a wide experience have been found to be very reliable, and from which we quote that in cutting metal one inch in thickness, what is known as No. 3 tip would be the best suited, with a pressure of acetylene from 3 to 4 pounds per square inch, and a pressure of oxygen of 20 pounds, whereas on a thickness of metal of ¼ inch, 10 pounds of pressure of oxygen would be sufficient, with an acetylene pressure varying between 2 and 3 pounds.

It should not be imagined, however, that even with the most perfect appliances, the process of oxy-acetylene welding and cutting can be mastered by reading instructions. Practical experience unfolds the mysteries of all arts, and whatever is rare in art is difficult of accomplishment, that is to the beginner. Personal instruction by some one skilled in handling such intricate appliances and using such amazing forces is almost absolutely necessary, not only as a mere matter of safety, but in the matter of economy, just as a traveler has more difficulty in finding his way through a forest than if he had the beaten track pointed out to him by one who has been over the ground. Even after some instructions and some personal experience, it is well to take new instructions, and new visions will come to the intelligent mechanic.

A thorough familiarity with the generating apparatus is necessary, as also the installation and operation of the same, and the construction of the reducing and controlling valves, so that the essential variable pressure necessary for the work in hand should be clearly known. The attachment of the torches, the absolute certainty that there are no leaks and that the torch-tips are of the proper size to weld or cut the metal, should not be matters of experiment. These have all been experimented with already, and do not come to the beginner over night.

In this connection it may be stated that unless the oxy-acetylene flame is accurately adjusted, too much oxygen will oxidize the metal, and too much acetylene will carburet it—either case being disastrous to the end aimed at. The strength of a weld is injured by a slight excess of either oxygen or acetylene, but there is a certain mixture that is correct, and with the properly designed equipment is always attainable.

From these preliminary observations it will be readily gleaned that this article is not intended to take the place of a skilled instructor, but rather to show the need of personal instruction and careful attention on the part of the learner. Much real injury has been done by unskilled hands in introducing the oxy-acetylene welding and cutting process, especially in some of the railroad repair shops, where

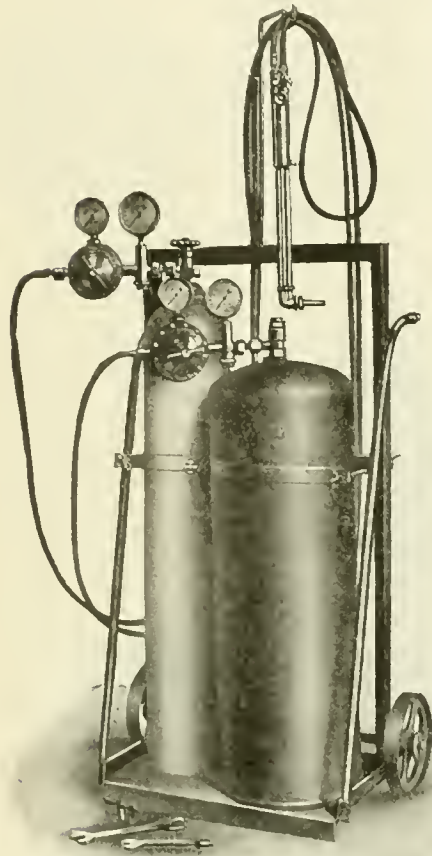

PORTABLE WELDING OR CUTTING UNIT.

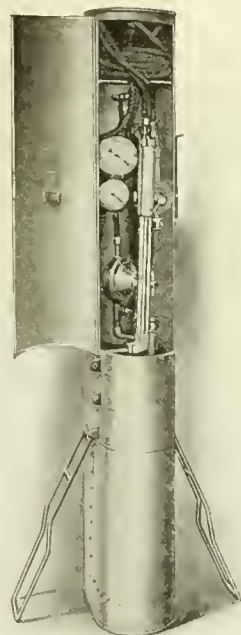

EMERGENCY CUTTING OUTFIT.

experiments of American engineers is such that there is now little or no variation in its qualities.

It may be mentioned that acetylene is to some extent soluble in water and other liquids but there is only one liquid commonly used for the purpose. This liquid is known as acetone and is produced in several ways among others from the distillation of wood. It is a colorless liquid boiling at 133 degrees Fah. and is also inflammable. It has the power of dissolving acetylene to the extent of about twenty-four times its own bulk at atmospheric pressure. As the pressure is increased the quantity of acetylene that will be reduced to liquid form is increased in proportion. Without this dissolution to liquid form any pressure above two at-

mospheres renders acetylene possible of self-ignition, and the danger increases in a ratio to the pressure. With the presence of acetone, acetylene loses this dangerous quality, and can be safely handled, the only remaining danger being that as the acetylene is dissolved the acetone increases its volume, and as the gas is drawn out of a closed tank the space left is full of free acetylene. This new danger is removed by filling the tank with some porous substance, asbestos being the most common in general practice.

The acetylene gas then dissolved and protected is forced into portable containers at a pressure of 150 pounds per square inch, for the use of consumers. The quantity remaining enclosed may be readily ascertained by knowing the weight of the empty cylinder and noting the difference between that amount and the weight of the cylinder containing the gas, one pound of which occupies about 14½ cubic feet. The complete equipment of present day practice includes besides the acetylene

its proper application would be an important economical factor, but where so much misspent effort is exhausted in keeping the rolling stock wheels turning without due regard to important factors that could not fail to expedite the end in view.

Coming to the details of the application of the oxy-acetylene torch, the valve in the oxygen tank should be opened very slowly, otherwise damage may be done to the regulator, which also should be opened slowly until the desired pressure for the

miliarity with the apparatus will instinctively come, and all feeling of inquiet in the mind of the operator in regard to the appliance should be eradicated before beginning real work, just as a soldier should instinctively know how to handle a rifle before commencing operations on the enemy.

A quick mastery is obtained by confining the initial efforts on one kind of weld, on one particular thickness of metal. Variety is confusing at first, as the readjustments are as delicately re-

road work boiler sheet welding is perhaps the most difficult of accomplishment, and should never be attempted by a beginner. Like all other occupations involving skill, followed by tests from which there is no escaping, much depends on beginning right. The natural bent is to fall into error, and to err is human, and it is also a fact that apparently insignificant trifles make perfection, but perfection itself is not a trifle, but a sure proof of the presence of the hand of a master.

In regard to the added material in welding, if the metal is 1/16-inch or less in thickness, no additional metal is necessary. All that is required is to describe small circles along the crack, the metal itself will flow together in a fused mass, but material thicker requires the use of welding rods. These rods or wires are of Norway iron in nearly all cases where steel is welded. The purity of this grade of iron makes a soft weld of even texture and great ductility. In cases where heavy steel castings are welded, a rod of carbon steel is employed. In high carbon steel it is preferable to use a rod of the same material, and for alloy steels, such as nickel, vanadium, special rods are supplied that have been found most suitable. These rods are frequently made at a slightly lower fusing point than the parts to be welded. This insures the fusing of the filling material before the parts can begin to cool. Care must be taken when adding metal that it is not added at a point that is not itself melted and fused with the addition that is made.

Chemicals are also necessary, generally in powder form, to keep the weld clean.

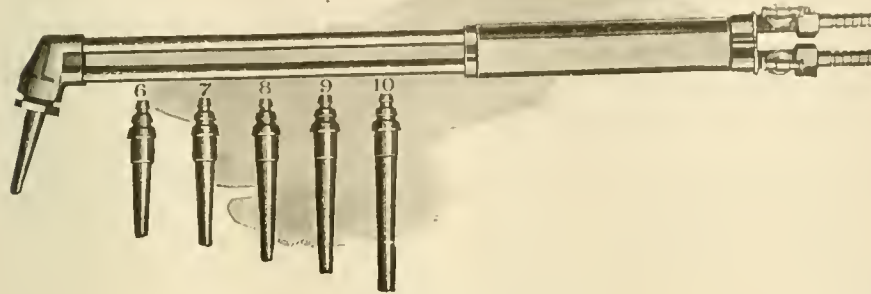

LARGE STYLE WELDING TORCH.

thickness of metal as shown in the tables is obtained. The working pressure should be advanced on the indicator from zero to the point required, instead of being turned on at a higher pressure and reduced. When the acetylene cock in the torch is opened, of course the gas should be immediately lighted, and the regulator adjusted so that there is a reasonably strong flame, then the oxygen torch-cock should be slowly opened until the oxygen reaches the full pressure, taking care to look at the indicators to note the pressure. Then the screw in the acetylene pressure regulator may, by turning, reduce or increase the pressure until the two cones of flame unite into one small cone of white flame, the pressures given by the makers for the tip used giving this condition accurately. An occasional slight increase of acetylene will show an extension of the flame at the point of the cone. An excess of oxygen will diminish the cone. The perfect mixture will neither burn nor carburet the metal.

The point of the white cone of flame should touch the metal in welding, but care should be taken not to touch the metal with the point of the torch or a flash-back may ensue, in which case the gases should be turned off momentarily. They can be readily relighted as the torch approaches the heated weld. In beginning for the first time experiments should be tried on welding thin strips of iron or steel 1/8-inch, or even less, in thickness. This may be done without the use of welding material, and the torch applied to the proposed weld by a slight upward and forward movement, thereby reducing the tendency to overheating. Several days should be spent on these light experimental operations, and a fa-

responsive as a touch on the piano, and the mastery of one tune at a time is enough for a day or two, whatever the neighbors may think.

In the matter of "safety first" glasses should be worn, although many operators prefer the naked eye, but they may live to regret it. If the flame is extinguished by any cause, the acetylene should be shut off promptly and the oxygen turned away from the heated metal. In confined spaces, or heavy welding, there should be two operators, so that the gases may be turned

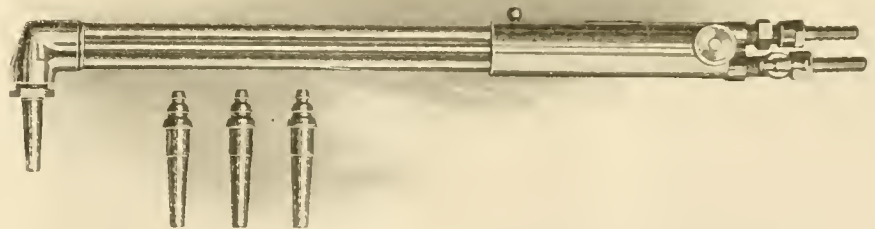

TWO-HOSE CUTTING TORCH.

off speedily, if necessary, or one may relieve the other to continue the operation without cooling. Excessive sparking indicates too much oxygen, and the metal is either being burned or oxidized. The amount of sparks, of course, depends also on the bulk of the metal, the volume, or shower, being in a ratio to the amount of metal heated by the penetrating torch. All surfaces should be carefully cleaned before being operated upon. Butt welding is preferable to lap welding, not only being easier to perform, but the certainty of an absolute weld is visible during the operation. In the various classes of rail-

These preparations are known as fluxes, and have the peculiarity of floating off physical impurities from the molten metal. They also furnish a protecting coating around the weld, and make a cleaner weld, thereby producing a better quality of metal in the work.

In closing this brief and elementary description of what may not improperly be called the manufacture of acetylene and the use to which it may be put when mixed with oxygen, we may state that our aim is to place before our readers, as briefly as possible, the nature of the marvelous phenomena which is one of the

crowning triumphs of the age in which we live, and which, when fully established in common use, will work a revolution in railroad motive power and rolling stock repairs. In this connection it is to be regretted that there is such a flood of proposed improvements in every department of railroad work that not infrequently the most clamorous are the most regarded, while improvements that are modestly presented are to some extent overlooked, but the universal adoption of oxy-acetylene in cutting and welding metals is inevitable, and we deem it our place and privilege to help on the good work, not to the exclusion of other valuable devices, but to the end that the full measure of all may be established. To this end in future issues we shall give more attention to this subject and present facts illustrated with instances and illumined with details. In this latter regard we will receive the assistance and co-operation of some of the skilled artisans who have

F. M. Titus and W. T. Rupert, traveling engineers of the American Locomotive Company. On November 29 the first engine took a preliminary trial trip of 50 versts or 33.1 miles. Vladivostock Harbor was rapidly filling with ice, which caused the steamers to be rapidly unloaded, breaking boxes, losing small parts, bending pipes and breaking studs. Many of the boats had to carry the large boxes lashed to their decks. It frequently happened that because of bad weather these boxes were awash for 10 to 12 days. In such cases all the bright work had to be repolished and many of the parts repainted. Three-fourths of the work of erecting the engines at Harbin was done by Chinese labor, and considering this fact and the many difficulties encountered, we believe this delivery to be a record.

It is interesting to note how the output at Harbin improved as the men became familiar with the work. Five loco-

### Railroading in India.

Not long ago a herd of wild elephants took possession of the short branch line between Latiguri and Ramshahi, in the Bengal Duars. The engineman of the train managed to frighten off most of them; one elephant, however, charged the engine and damaged it slightly, but was itself thrown off the line with, it is believed, a broken leg.

### The Holland Railway.

The report of the Holland Railway Co. for the year 1915 shows heavily increased expenses over 1914. Labor, fuel, taxes and supplies generally were higher. But the total receipts were 20 per cent. above those of 1914, largely due to fares of soldiers traveling to and from their homes when on leave. The net result, therefore, was a dividend to stockholders of 5 per cent., against 3 per cent. in 1914.

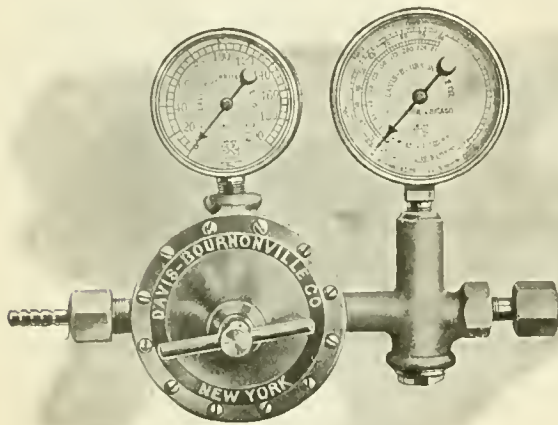

OXYGEN PRESSURE REGULATOR.

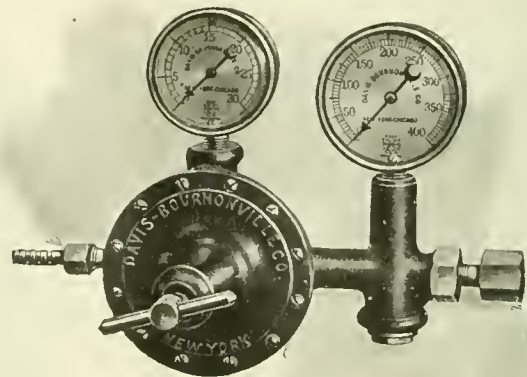

ACETYLENE PRESSURE REGULATOR.

already mastered the art of oxy-acetylene welding and cutting, and so add to our educational work, and in this aim we are assured that our efforts will be fully appreciated.

### Russian Decapods.

One hundred locomotives of the Decapod, or 2,100 type, have been built by the American Locomotive Company for the Russian Government, and described in our issue of December, 1916. Delivery was an important factor, and it is interesting to note that the first locomotive was completed, tested under its own steam, taken apart, boxed and shipped one month after the drawing room work was completed. The first six engines were shipped by steamer from New York on August 29, 1915, and arrived at Vladivostock on October 27, 1915. They were then shipped by rail to Harbin, Manchuria, where they arrived on November 12, and at which point they were assembled under the supervision of

motives were completed in December, 5 in January, 19 in February, 40 in March and in the first seven days of April 11 engines were completed. The eightieth locomotive, which is illustrated, left Harbin, Manchuria, for Russia on April 7.

### Electric Currents in South Africa.

The Victoria Falls & Transvaal Power Co., of Johannesburg, is by far the largest power and lighting company in South Africa, and it supplies from its four large stations nearly all the gold mines and reef towns with both power and light, transmission being by 3-phase long distance, 40,000 volts overhead. Distribution is by 20,000 volts underground and 10,000 overhead. The generating sets used are A. E. G. turbo-alternators, standard sizes, viz., 9,000 kw. = 12,000 kva., and 3,000 kw. = 4,000 kva. The station voltages are 2,240, 5,000 and 10,500. The distances traversed by the electric current are said to be the longest in the world.

### American Locomotive Company.

It is gratifying to learn that the American Locomotive Company has received such a large increase in orders for locomotives that there is no intention on the part of the company to make further estimates on the manufacture of munitions. The company's extensive orders for the latter class of work is expected to be completed before the end of the present year.

### Would Have Saved the Cow.

The following story is told of remarks made by an Irish barrister in a court of law. He was for the plaintiff, whose cow had been knocked down and killed by a railway train. His contention was:

If the train had been run as it should have been run, or if the bell had been rung as it should have been rung, or if the whistle had been blown as it ought to have been blown; both of which they did neither, the cow would not have been injured when she was killed.

### Lighterage in New York Harbor.

A particularly interesting paper on "Lighterage" by Mr. Henry L. Joyce, manager Maintenance Department, Central Railroad of New Jersey, occupied the attention of the New York Railroad Club at a recent meeting.

The whole of the paper is thoroughly worth reading, but we can spare space for only the following paragraphs:

The story of the development of the present great lighterage system operated in New York Harbor is as interesting and phenomenal as the wonderful growth of our great railroad systems. The Trunk Lines reaching New York could not be operated without a proper lighterage system. They are inter-dependent, and the expansion of one makes necessary the expansion of the other.

Without an efficient lighterage system none of the railroads could properly handle the enormous tonnage arriving at the seaboard, requiring transportation across water, and chaos would take the place of prompt service and efficiency, if our lighterage system failed to keep pace with the ever-increasing tonnage.

The different style of craft used from decade to decade, the improvements in the mode of transfer across our harbor and its tributary waters, as well as the great changes from time to time in the class of traffic handled, is an interesting story to hand down to those who will come after us in the management of our great transportation systems.

The first lighterman in New York Harbor started business in the early forties, with an office in the Flour Exchange, which was located in a small store at South and Broad streets. This little store, then known as the Flour Exchange, has since developed into the great New York Produce Exchange. His fleet consisted of three little scows, none of them carrying over fifty tons of cargo. His business grew rapidly, and it was only a short time before his fleet increased to seven boats.

At this time nearly all the traffic coming into New York City was brought down the Hudson river on barges, the New York Central tonnage being so lightered from Athens to New York and the Erie railroad tonnage coming by the same method from Piermont. All freight arriving by Pennsylvania railroad was landed at the old Camden and Amboy Dock at South Amboy, and lightered to New York City by barges.

#### CAR FLOATS.

The introduction of the car float has proven a greater economy to the railroads than the introduction of any other class of floating equipment. By its use the railroad companies transport entire trains from any inland point in the country to the seaboard, across water to alongside of ocean steamers and warehouses and the

terminals of other roads, without breaking bulk or any rehandling en route.

This class of vessel saves the railroad company the expense of unloading at their railroad terminals on to the lighter, transportation by lighter across water, wages of crew of the lighter, the service of the lighter itself and all other expenses incidental thereto. Trains of passenger cars are carried across water by this method, and this has eliminated in many instances the enormous cost of construction and maintenance of bridges.

At first all of the car floats built were constructed entirely of wood and to carry only six cars. From time to time the dimensions of the car float increased and construction generally changed from wood to steel, so that the great advance in this class of vessel has been made from the wooden float 125 feet long, carrying six cars, to the present float built entirely of steel with three tracks, 330 feet long and carrying as many as 23 cars. Floats are used exclusively in the transfer of all light and loaded cars across water between connecting roads, and between terminals and regular New York and Brooklyn freight stations, and entire cargoes of perishable freight are handled in the most expeditious manner.

The floats are placed alongside of the fruit steamers the moment they arrive in port; her cargo of bananas, lemons, oranges and tropical fruits are unloaded quickly from the steamer direct into the cars; on completion of loading, a tug is always ready to rush float to respective railroad terminal, and perishable fruit is laid down in Buffalo, Washington, Pittsburgh and other distant cities within twenty-four hours after its arrival in New York and without any rehandling from the steamer to its point of destination.

#### Railroads and State Lines.

It is now proposed in certain high places to "iron out" the differences between interstate and intrastate commerce—a consummation devoutly to be wished. There is no more reason for the recognition of State lines than there is those of the counties, as far as railroad and other traffic is concerned.

That every State should have its railroad commission, ruling often in direct opposition to the Interstate Commerce Commission, puts our claim to national efficiency to shame. Until the State lines are eliminated with respect to controlling the railroads we shall always have weird rates.

Under Federal control and without the interference of superfluous State authorities our arteries of commerce would quicken with the flow of healthy commerce.

The sooner the country rubs out the State lines in this respect the sooner will its economic circulation become normal.

#### Railway Accidents in Great Britain.

The annual report of the British Board of Trade shows that in tram accidents on the British railways for the year 1915, there were 269 passengers and 9 employees were killed, and 1,432 passengers, 183 employees and 2 other persons were injured. The number of passengers killed (269) compares with 6 in the preceding year. The record for 1915 includes the disaster at Quintinshill, Scotland, on the Caledonian, May 22, where three trains were wrecked and over 200 soldiers were killed.

#### Railroads in Siberia.

In the 25 years since the beginning of construction of the Great Siberian Line, there have been built in Russian territory alone 5,255 1-3 miles of railroads. In recent years the following are the principal additions: Altai Railroad, 500 miles; Atchinsk-Minusinsk Railroad, 287 2/3 miles; Kolchuginskaya Railroad, 139 1-3 miles; Kulundinskaya Railroad, 196 2/3 miles (over 60 miles ready); Omsk-Tyumen line, 35 2/3 miles. The Siberian and Transbaikal Railroads are double-tracked to a great extent. The Ussuri line is undergoing an almost entire reconstruction, which will be finished in a short time.

#### Big Year for the Santa Fe.

One of the large western lines that is enjoying the fruits of prosperous conditions and of good management, is the Santa Fe Railway. It is one of the leading granger roads and reflects the conditions of the West and southwest. President Ripley, of the Santa Fe, is quoted by the daily press as saying that their road is closing up its greatest year in earnings, which he states will amount to more than 11 per cent. The Santa Fe's net earnings for April are approximately \$1,400,000 better than they were for April, 1915. Everyone in the Santa Fe territory is prosperous, particularly the farmers, says Mr Ripley.

#### Women in Sleeping Cars.

Sleeping cars were for several years held for the exclusive use of men, women not being admitted to their sacred precincts. The first break in this rule was made in favor of Mrs. Lincoln, wife of President Lincoln, when she was on her way from the west to Washington in 1861. The Wagner Car Company put a sleeping car at her disposal and it was used on the journey from Springfield, Ill., to Washington.

With some people, such as sleeping car porters, women are not yet welcome inmates of a sleeping car. "What kind of a crowd have you tonight?" the writer heard one porter ask of another. "A poah lot," answers the darky, reproachfully; "only a lot of women. The whole bunch not worth a dollar." Women do not readily fall into the tipping habit.

# Test of Locomotives

By MR. D. R. MacBAIN, Superintendent Motive Power, New York Central Railroad

Mr. D. R. MacBain, superintendent of Motive Power, New York Central Railroad, delivered an address before the members of the Western Railway Club at Chicago on tests of locomotives, which has been the subject of much comment among those who had the pleasure of hearing the address. As is well known, Mr. MacBain has given much attention to all matters affecting the development of the modern locomotive, and more especially to boiler construction and maintenance. In this department he is in the front rank of authorities today, and experiments conducted under his supervision have a potential value that has opened up new lines of thought, and suggested new lines of investigation, which are leading to paths of real improvement.

The illustrations are numbered so that the matter will be readily understood by all who are in any way familiar with locomotive boiler construction and repair, and will be of special interest to that large class who are interested in the improvement of boiler construction looking

one that aroused his suspicion, so to speak, was a new boiler that had only been in service about four months; at the end of that time it was found neces-

time, the fire was dumped out quickly, and Mr. Linderman and his assistant immediately went inside of the box and tried the tram on the marks that were made when the box was cold, and immediately following this they tried the tram to the outside marks with the result that they found that the tram marks on the fire sheet were  $3/32$  inch closer together than they were on the outside sheet.

This experiment was afterwards tried under more favorable circumstances at West Albany shop in 1910, when a wide-firebox boiler was selected, and a set of trams of solid steel were prepared, and a set of marks, as shown on the slide, made from these trams. The boiler was then fired up and, when 200 pounds pressure was raised and the pops had been open for a few minutes, the fire was drawn hastily, during which process the trams

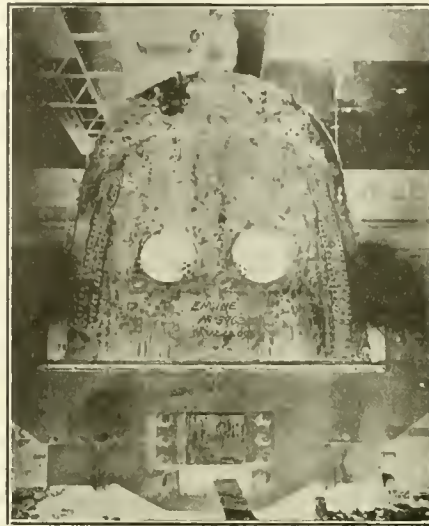

FIG. 2.

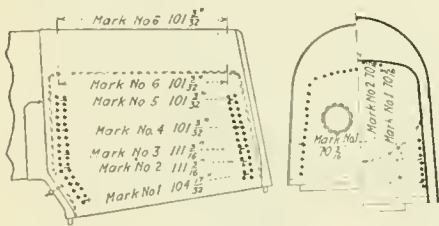

FIG. 1.

towards the economy in the use of fuel. Referring to Fig. 1, Mr. MacBain stated that experiments were made in order to determine why certain fireboxes in the

sary to put in new sheets, so it was taken out and returned to the locomotive company.

"We wanted to find out what the trouble was, and Mr. Linderman, boiler-maker on the Michigan Central Railroad, conceived the idea of finding out whether there was any difference in the length of inside sheets as compared with the outside sheets under the varying conditions of heat and pressure. We took one of the engines that had a boiler exactly like the one that failed, and after making the tram marks as indicated on the slide, on

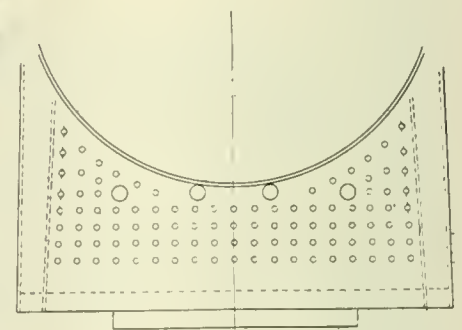

FIG. 3.

were tried to their respective marks on the outside sheets, and immediately afterward (within a few minutes) the trams, in the proper order, were tried to the

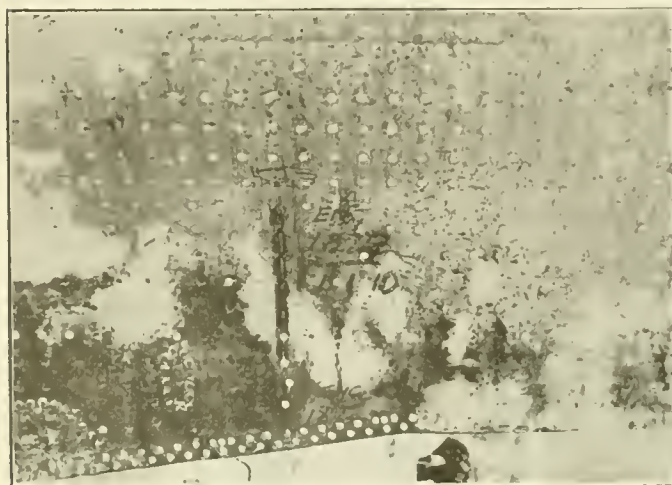

FIG. 4.

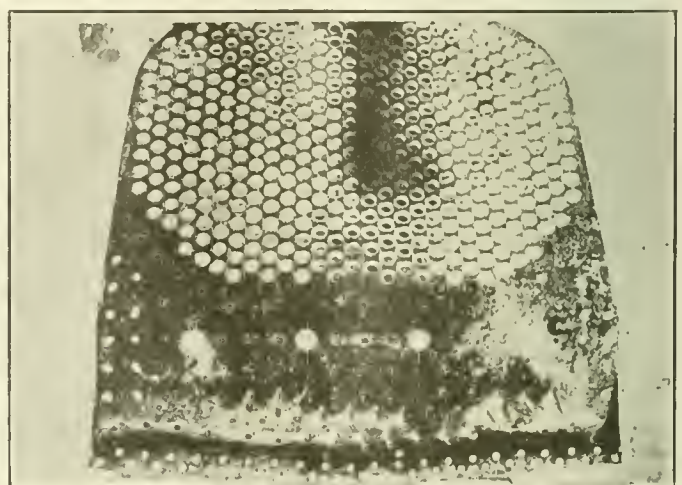

FIG. 5.

very early stages of their existence gave a great deal of trouble through the side sheets cracking vertically between the staybolt holes, and in one instance the

the inner and outer sheets, when the boiler was cold, the engine was then fired up, and after 200 pounds pressure had been raised and the pops open for some

marks on the inner sheets, and the figures shown in the table are the result, indicating that the expansion of the outer sheets was greater, in every case, than that of

the inner sheets, as indicated in the following table:

Mark No.	Location	Outside Wrapper Sheet Expansion
1	Side Sheet	3/16 inch
2	Side Sheet	5/32 inch
3	Side Sheet	1/4 inch
4	Side Sheet	3/16 inch
5	Side Sheet	7/32 inch
6	Wagon Top	7/32 inch
1	Throat Sheet	5/32 inch
2	Throat Sheet	3/16 inch
1	Back Head	5/32 inch

Location	Expansion	Difference in Expansion
Side Sheet	1/8 inch	1/16 inch
Side Sheet	3/32 inch	1/16 inch
Side Sheet	5/32 inch	3/32 inch
Side Sheet	1/4 inch	1/16 inch
Side Sheet	3/8 inch	3/32 inch
Crown Sheet	5/32 inch	1/16 inch
Tube Sheet	7/64 inch	3/64 inch
	1/8 inch	1/16 inch

(No Record on door sheet)

thus verifying our opinion in that regard, and seemingly accounting for the break-

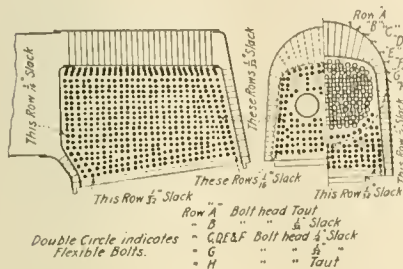

FIG. 6.

age of the back heads and throat sheets along the outer row of staybolts; also the vertical cracks in the side sheets, as well as the cracks from the water-bar holes, as indicated in Figs. 2, 3, 4 and 5. This theory is borne out by the movement of the needle shown extending through the throat sheet, Fig. 1, as, when the fire was first started, and before circulation was fully established, the needle moved out 3/32 inch, and later, when circulation was established and the steam pressure began to rise, the needle moved backward about 1/16 inch. The first movement of

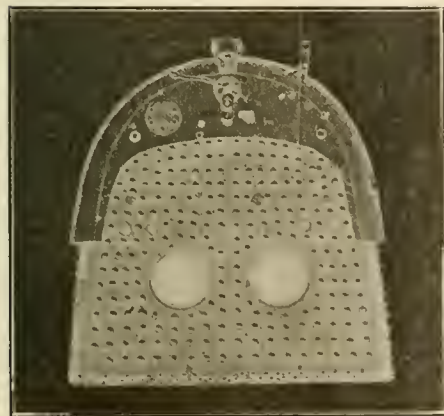

FIG. 7.

the needle, we think, throws some light on the cause of side sheets puffing along the fire line, as they sometimes do.

Fig. 6 shows, to the left, an installation of flexible staybolts, which, when adjusted, as shown by the tables and notes,

in our opinion, will relieve the stresses that are the cause of the failures indicated in Figs. 2 and 3; and, to the right, the same installation and method of adjustment of flexible staybolts in the first and second rows on the side at each end to relieve the stresses that we believe are responsible for the failures shown in Figs. 4 and 5.

Our experience on the New York Central and Michigan Central has been of the most satisfactory nature in preventing cracked sheets and leaky side-sheet seams, and we are of the opinion that an installation of flexible staybolts, set loose, as shown in Fig. No. 6, with this difference, we believe a full installation in the throat sheet, set loose as follows, is advisable:

First row above mud rings..Tight  
 Second row above mud ring.1/32 in. loose  
 All others .....1/16 in. loose  
 And the back flue-sheet braces 3/32 in. loose and will increase the life of a modern firebox from 50 to 75 per cent.; the loose installation of flexible staybolts in the throat sheet, and slack braces to back flue sheet, that will be shown in Fig. 17, being considered necessary in order to avoid excessive staybolt and flue-sheet brace breakages, and at the same time reduce the strain on the arch-flue anchorages, the latter being quite a source of trouble when they begin to blow, especially at the front end.

Figs. 7 and 7a represent the first engine in the United States, I believe, that ever had an entire installation of flexible staybolts. It is an Atlantic type, and the full installation of flexible staybolts was made in February, 1907, when the engine received a new firebox. All staybolts were of the Tate flexible type with the exception of four bolts under the popper dome and four under the steam turret, and eight bolts which go on top seam of back head. Those that were not flexible were sling stays, as shown in Fig. 8.

In February, 1908, this engine again received general repairs, and the firebox was in good condition. All caps were removed from the flexible staybolts and they were found to be in good condition. In April, 1909, it was found necessary to patch the top of the back tube sheet on account of the sheet cracking from the tube hole around flange. This was done in the engine house. Also in that year, this engine again received general repairs, and by that time the top of back tube sheet had given out in two more places, but as sheet was in good condition otherwise it was again patched. Three of the mud ring corners also had to have small patches applied. No broken staybolts were found at that time. In April, 1911, the engine was again in shop for general repairs, at which time all caps were removed from the flexible staybolts and the staybolts were found to be sound.

Patch was applied on top flange of flue sheet on left side.

This engine had made 319,067 miles to November 1, 1911. In July, 1912, the engine was again in shop for general repairs, and all flues were reset, mud ring corners calked, and new back tube sheet applied; crown sheet and water space cleaned; caps were removed from all flexible staybolts and no broken staybolts were found.

Up to January 1, 1914, this engine had made 440,189 miles dating from the time

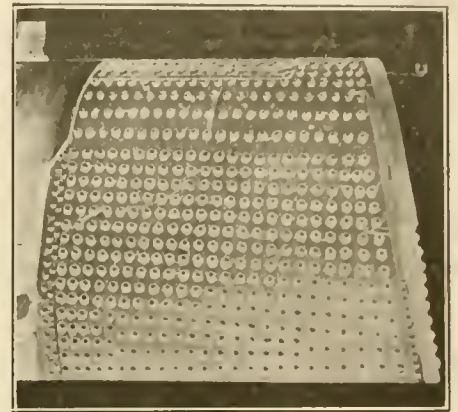

FIG. 7a.

new firebox was applied in February, 1907.

In March, 1914, engine was again in shop for general repairs,—caps were removed from flexible staybolts and all staybolts were good, a patch was applied on right side sheet, size 24 x 36; patches were also applied on corners both right and left sides. In March, 1915, when the engine was again in shop for machinery repairs, both front corners, also left back corner, were patched, and no broken staybolts were found at that time. In October, 1915, superheater was applied, also new side sheets, flue sheets and door sheet, and no broken staybolts were found. Up to that time this engine had made a total of 500,000 miles, without a flexible staybolt failure.

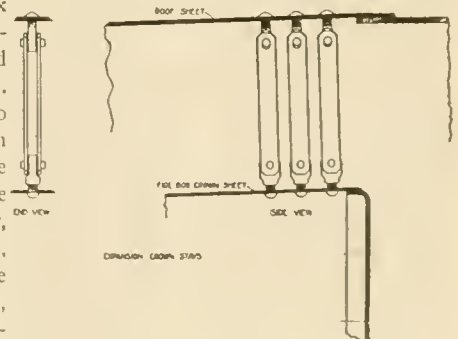

FIG. 8.

This is the same engine showing the installation as it was made in the sides. The manner of installing the bolts on that engine was probably not quite as methodical and up-to-date as we do it nowadays, but it was fairly good."

# Difference of Force of Impact Between Vehicles in a Moving Train of Cars

By WALTER V. TURNER, Assistant Manager Westinghouse Air Brake Co.

In connection with the subject of design of an efficient brake for a heavily loaded freight car, I wish to touch upon the effects of slack action encountered in a train on level track, and first establish the necessity for an efficient brake for the loaded car when on level track as well as to emphasize the necessity for such a brake in descending heavy grades. By the way of an approach to the subject, I will repeat certain parts of a paper read before the St. Louis Railway Club at a recent meeting which will convey an idea of the forces that may be set up between the different cars of a train by the action of the air brake. Many of the readers may wonder how it is that a draft gear member, a yoke, for instance, should be broken in service on a car weighing, say, 160,000 lbs., loaded, when upon an examination the yoke reveals no particular defect and yokes of an identical size, when pulled on a testing machine, require a force averaging between 200,000 and 300,000 lbs. to rupture them; in other words, a force far exceeding the weight of the vehicle upon which the yoke was broken?

The illustration and formula shows what the force of impact may be for a difference in velocity of only one mile per hour between two cars when the impact takes place in 1/100 of a second—a very reasonable time for impact, but something exceedingly difficult of exact determination.

A purely elastic impact has been chosen as basis for this curve for mathematical simplicity. When two lead balls come together the impact is inelastic, that is, the coefficient of restitution is approximately zero. In other words, the surfaces of contact have zero tendency to return to the contour obtaining before impact takes place. On the other hand two hard steel, ivory or glass balls have very nearly purely elastic impact. That is, the coefficient of restitution is approximately unity, by which is meant the surfaces compressed during impact would, like a spring, return practically all the energy used in compressing them and would return very nearly to the exact contour it had before impact. The F. t. used in making the curve of the figure attached is the summation of the product of all instantaneous values of the force and time of impact. The force ranges from nothing at the beginning of the impact to its maximum at the end of the full time of impact in the case of inelastic impact. In the case of elastic impact the maximum force occurs at the mid-point of the

time and tapers down to zero again at the end of the full time of impact. According to this, if the force varies directly with the time, the time to give the maximum force shown in the curve need be only 2/100 of a second instead of one. The maximum force is the one with which we are most greatly concerned in the case of collision between cars, and, other things being equal, it does not make any difference to the intensity of the blow whether the elasticity, in the way of restitution, is great or small, but it makes a vast difference in the case of a train of cars in the way of causing a final velocity for the following car much less than that of the leading car. That is, when the elasticity, or coefficient of restitution, is zero, the two cars will move on after im-

stance, lead as well as steel, has an elastic limit, but this limit, for substances of low moduli of elasticity is so far below the stresses involved in the every day world that, in the case of lead, for instance, the elasticity is practically zero. That is to say, a stress which might be applied to a piece of steel without giving it a permanent set, i. e., carrying it beyond the point (the elastic limit) from which it would begin to fail to return to its original shape upon removing the stress, would permanently deform a piece of lead or a piece of rubber which, contrary to the popular conception, is of low elasticity. Rubber is elastic in the popular sense that a very small force will stretch or elongate it a great deal, but it is inelastic in a mechanical sense that a

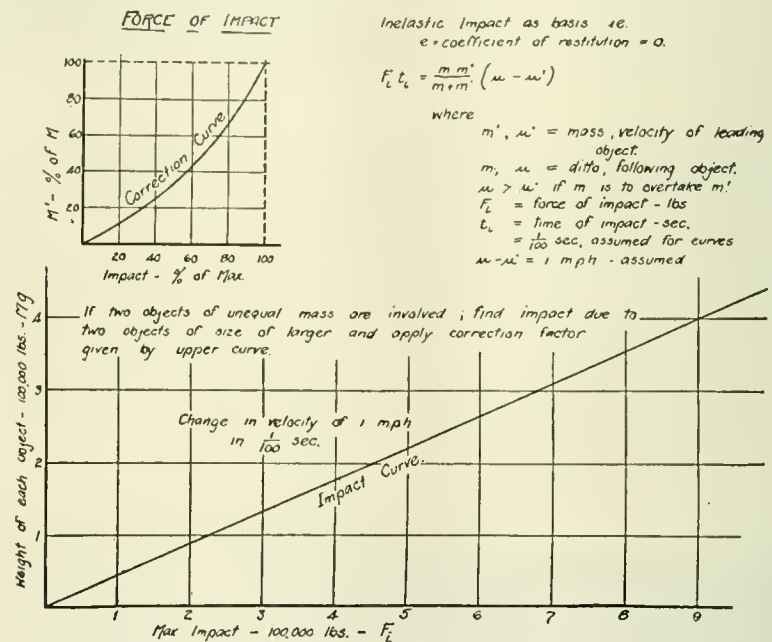

DIAGRAM SHOWING FORCE OF IMPACT BETWEEN TWO CARS.

pect with the same velocity, i. e., zero velocity difference. But the velocity difference after impact will be greater as the coefficient of restitution approaches unity. In other words, the greater the elasticity the greater its recoil or "kick back," and therefore the greater accumulative velocity difference between succeeding cars and, correspondingly, the greater will be each collision as the slack action passes on through the train.

In this connection it is impossible to dissociate the two phases of elasticity—the one involving restitution of form and energy and the other involving the modulus of elasticity, or unit stress (force per unit area) per unit elongation within the elastic limits. Every sub-

comparatively small stress will take it beyond the elastic limit and break it.

As the elasticity of a substance is greater, the elongation for a certain stress is less and the "give" or "cushioning" effect of a blow is less. Therefore, the stress caused by impact must run up higher in value as the elasticity is greater in order to total an impulse equal and opposite to that of the blow. All of this may be summarized in saying that in dropping from the same height two balls of equal mass, one of rubber and one of steel, against a steel bed plate, the steel ball, being the more elastic in the mechanical sense will deliver the greater force against the bed plate.

Just what degree of elasticity exists



when two cars come together it is impossible to say. It is true that the elasticity, or coefficient of restitution, is less for friction draft gear than it is for spring draft gear and a condition of zero elasticity would be the ideal, having in mind for the measure of this elasticity a time interval approaching that of the impact, for, obviously, after the blow has taken place, it is indispensable that the draft gear resume, rather quickly, its initial position in order to be ready for a succeeding impact.

The assumption of a velocity difference of one mile per hour for the formula shown is very conservative. With an empty car braked at 60 per cent. having a rigging efficiency of 85 per cent. and a brake shoe friction of 15 per cent. the retardation set up is

$$.60 \times .85 \times .15 = 7.65 \%$$

Which means a rate of change of velocity of

$$.0765 \times 22 \text{ M. P. H. per sec.} = 1.68 \text{ M. P. H. per second.}$$

This because 22 miles per hour per second represents 100 per cent. retardation, namely that due to gravity, or 32.2 feet per second, per second. For a fully loaded car the retardation is only one quarter of this, or,

$$.25 \times 1.68 = .42 \text{ M. P. H. per second.}$$

The difference in change of velocity be-

tween the empty and loaded car is,  $1.68 - .42 = 1.26 \text{ M. P. H.}$  for every second. Now if a 10-pound brake pipe reduction be made instead of 20 lbs., giving 17 or 18 lbs. cylinder pressure instead of 50 lbs., the braking force will be about one-third its full value, and the velocity change per second will be about one-third the above value,  $1.26/3$  or  $42 \text{ M. P. H.}$  In order that a velocity difference of one mile per hour be set up it would be necessary that this difference in retardation between empty and loaded cars continue for only  $1/.42$  or 2.4 seconds, and that  $.42 \times 1.467 \times 2.4 \div 2 = 7.4$  feet of slack obtain to permit this velocity difference and the impact due to such difference. That is with an average of one foot of slack per car, and with the slack bunched between a string of loads ahead and empty cars behind, due to a 10 lb. reduction just having been completed, at the brake valve, in about 2.5 seconds time the eighth empty would be jerking on the seven empties ahead which had just run out on the string of loads. This eighth empty would be running at about one mile per hour slower than the car ahead at the instant of impact, and the blow due to impact would be something over 200,000 lbs. From the curve a car weight of 40,000 lbs. would give an impact of only about 100,000 lbs.—pro-

vided the second car which affords the impact is of the same weight. But when an anchor of 10 or more times the weight of the first car affords the impact, the force of impact becomes twice the value given by the curve. In the illustration used seven empties and the loads ahead provide the anchor against which the eighth empty jerks. By the time the sixteenth empty runs out the velocity difference is twice the one computed, other things being equal, and therefore the blow of impact is doubled, that is, 400,000 lbs. Hence it becomes plain why a draft gear yoke, capable of sustaining the weight of its own car, or even a number of such cars, if suspended vertically, is so easily broken in service. The illustration also shows why it is so many damaging shocks due to slack action occur every day, and it is amazing that more of them are not experienced with the great diversity in car loading, train make up, brake equipment, brake maintenance, etc.

Brake maintenance is mentioned along with brake equipment, for it is easy to see that short piston travel on empty cars accentuate the difference in retardation in a mixed train, and also variable piston travel in a train uniformly made up of all empties or all loads sets up surges or slack action in exactly the same way as pointed out in the illustration.

## Method of Attaching the Ends of Superheater Flues to the Header of the Robinson Superheater

By FRANK PAGE, New York

In the July issue of *Railway and Locomotive Engineering* there is published an account of the Robinson Locomotive Superheater. A desire is expressed that some of your correspondents would enlighten you in regard to the method of working the unit ends. As I am familiar with a superheater in this country employing expanded tube joints for the connection of unit tubes to the superheater headers, I am pleased to explain this practice to you.

At the start it should be remembered that abroad, where there are many makes of locomotive superheaters, the expanded joint is very common and is used there on the German superheaters which employ the ball joint in this country. Having a patent on the ball joint in the United States, but on no other essential part of the superheater, it is natural that the makers should advocate and push it to the limit. The foreign practice cannot be said to favor such a joint and expanding the tubes is the most common practice. There is no question whatever that boilermakers and mechanical experts agree that the best method of attaching the ends of a tube to its sheets is by expanding. This applies, of course, to tubes which must be periodically removed and are not practical to weld in place.

A satisfactory method of attachment having thus been determined through years of experience, there remained the problem of detaching the tubes in a satisfactory manner. In the case of locomotive superheater unit ends the term "satisfactory" in the highest degree would mean the ability to remove and replace the tube ends without cutting, safe-ending, or the necessity of employing special and complicated tools. The smaller the amount of work and expense entailed, the more "satisfactory" from the railroad point of view. These requirements can all be met, and with surprising ease, in superheaters where simple expanded joints are used, such as the Robinson or Foster.

Persons of limited experience with heavy gauge tubing are not likely to accept such statements without question, but the fact is that ordinary gauge tubing, such as locomotive tubes, cannot be handled in the same manner that superheater tubing can. Those who have not had experience with this tubing are pretty certain to be ignorant of its characteristics and advantages. A study of Mr. Robinson's various patents would have made it clear to the writer of the article in question that there are very simple means for removing unit ends without cutting or safe-ending.

It has not been found necessary to employ even the tube pushers which the English design contemplates, and we enclose herewith sketches showing what is probably the simplest method of removing the units. Tests made on this type of joint have shown that  $1\frac{1}{2}$  inch tubing of 8 or 9 gauge stock can be expanded into its seat tight enough to hold pressures exceeding 1,000 pounds per square inch without even a sweat and yet be driven out of the seat with a hand hammer or light sledge. The process is as follows:

The unit tubing is slipped up into its seat in the header so that the end projects above the sheet about the thickness of the tubing, say  $3/32$  inch. This tubing is then expanded with an ordinary three roller expander and the tube is not belled, beaded, or flared in any other way. The small diameter of the tubing and the heavy wall will produce a joint relatively so much stronger than the ordinary belled and beaded boiler tube that there is no comparison.

To remove these tube ends a small drift is made which will fit easily into the tube and which has a shoulder that will freely pass through the hole in the header. This drift can then be hammered down, either directly or by placing a bar

upon it, until the unit is free. This process does not require any special skill or care and does not injure the unit end. In some cases the ends have been annealed before replacing in order to eliminate any crystallization due to expanding, but no failure has as yet shown this precaution to be necessary. A great many cases where the tubing has been driven out and then replaced and re-expanded, either

were safe ended about a foot below the header by an ordinary oxy-acetylene torch and the ease with which this was accomplished demonstrated that if trouble ever should develop with a unit end, the piece could be replaced in a few minutes by an acetylene welder. In this particular instance the ends of the tubing to be welded were roughly beveled back at an angle of about 45 degrees. A long

that a very smooth surface had been produced. The units were placed in the boiler and test pressure applied with the pleasing result that not the slightest sign of a leak could be found. These elements have now been in service for more than half a year and no trouble has been reported. This again shows that heavy tubing can be worked in a far more satisfactory way than thinner stock and results totally unbelievable to those not familiar with it can be obtained.

One other point which may not be clear is the replacing of unit ends in their seats in the header after having been driven out. It might naturally be expected that a very tight fit would be encountered and much trouble experienced in forcing the tube ends into place. That this does not occur is best proved by the fact that in practice it never has. Light tapping has been sufficient to enter all unit ends and without special preparation.

The foregoing remarks, it is hoped, will clear up the doubts and uncertainties of those who are not familiar with the construction and care of modern locomotive superheaters. The statement in the article that the joints in the Robinson superheaters observed were not as tight as they should have been sounds unnecessarily misleading, for although such might have been the case it certainly is not the fault of the Robinson design else nearly all the boiler tubes in the world are incorrectly secured in place. It would interest me very much to know whether the English practice is to use a roller expander, for it has been found in this country that a properly rolled joint is good for much greater pressure than could possibly be put on the boiler.

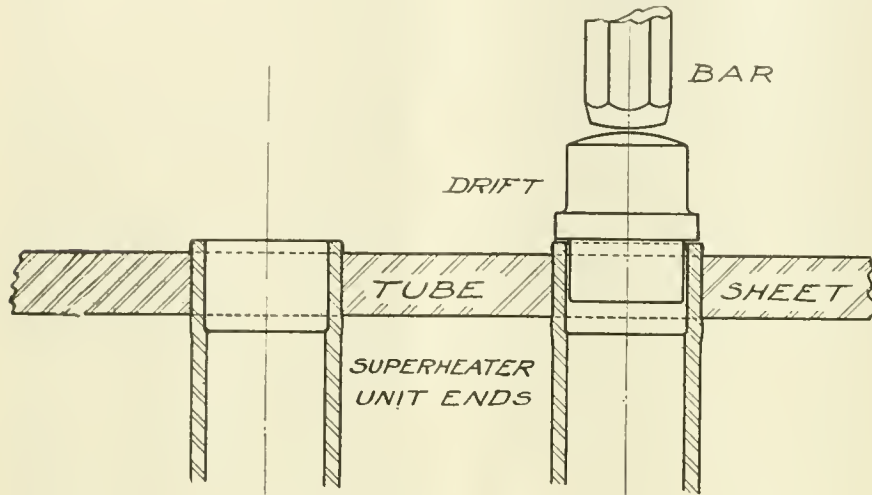

DEVICE FOR REMOVING FLUES FROM HEADER IN ROBINSON SUPERHEATER.

without any attention whatever or else after lightly rubbing over with emery cloth, have shown absolutely that this is a most "satisfactory" manner to make the header connection. The heavy metal is susceptible to much more rolling than ordinary boiler tubing and repeated removing and replacing in different round-houses has not brought to light any trouble. From theoretical considerations, certainly, none would be expected.

In one locomotive half a dozen units bolt was then inserted to keep the short piece in line with the unit tube. The two pieces were kept separated by about 1/16-inch until the operator had tacked the tubes at two or three points around the circumference. The bolt was then withdrawn to eliminate any chance of its sticking due to the heat, and the welding was completed. An examination of the interior of the tubing by means of a small electric light showed that there had been no burning through of the metal and

## Wyman's Automatic Drifting Device

By JOHN MILTON CLEARY, Delmer, Del.

Drifting devices are being much discussed in engineering circles at present. The article which appeared in June issue

urged at the last convention of the Traveling Engineers that a satisfactory device be designed this subject is occupying the

Delaware Division of the Pennsylvania R.R., and is being used extensively on the P. B. & W. R.R., having been installed

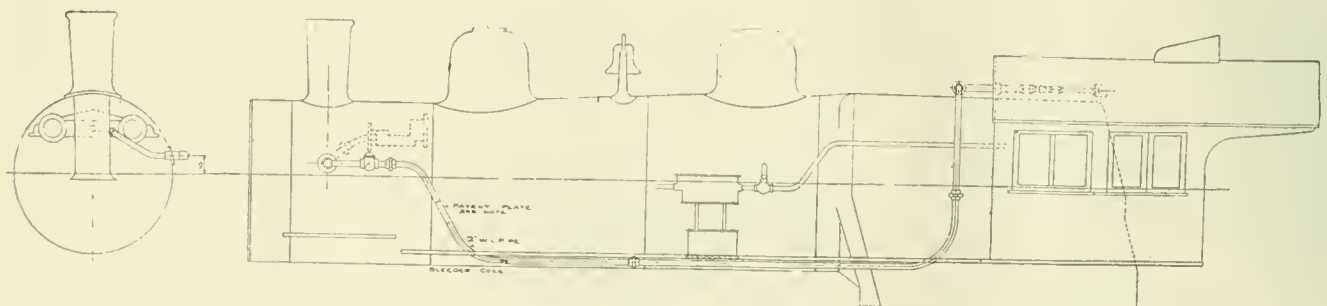

VIEW SHOWING DETAILS OF DRIFTING APPLIANCE IN FRONT END.

of RAILWAY AND LOCOMOTIVE ENGINEERING, by Mr. F. Roesch, explaining the operation of the combined drifting and relief valve was read with great interest, and since the committee on drifting valves

minds of not a few able mechanical men engaged on railways at this time.

The Wyman Automatic Drifting device was designed and patented by George W. Wyman, assistant road foreman of engines,

and successfully operated on the following class P. R.R. engines: K 2 S a, E 6 S, E 3 S D, D 16 SB, H 9 S.

The device which has been installed on D. & H. Locomotive No. 1200 was recently

demonstrated at Carbondale by Mr. Wyman personally, to the satisfaction of all concerned. This engine has very large cylinder dimensions, being 27 by 32 inches, with relief valves in both steam chest and cylinder, yet during the demonstration, while engine was being drifted down the mountain, no difficulty was experienced whatever in keeping the relief valve closed with the amount of steam that passed through drifting device to valve chambers and cylinders, this in turn eliminating the

engineman must open the starting valve. This will allow a low pressure to go to the steam chest and cylinders, but will not interfere with the movement of the engine, as the reducing valve will close when the pressure it is set for is obtained.

The starting valve is not to be closed by the engineman until the trip has been completed. When the engineman opens the throttle, the higher pressure in the steam chest will close the check valve and prevent the low pressure from going to

passing the centre. The device is automatic in action; the check valve divides the two pressures.

On account of having a volume of steam in the cylinders at all times constant lubrication is assured and engine is more easily started on account of having no frictional resistance to overcome. This device is connected in front header for the purpose of using saturated steam to cool the cylinders, which is more preferable on account of the extremely high temperature of su-

NOTE  
BRASS PLATE BEARING FOR  
APPLICABLE TO THE TRIP-LEVER  
PATENTED BY GEORGE W. SIMAN, MICHIGAN  
PATENT, NO. 1,230,176.



VIEW SHOWING DETAILS OF DRIFTING APPLIANCE IN CAB.

pound in boxes and rods, which was very noticeable when the valve was closed and no steam passing to the steam chest and cylinders.

The automatic drifting device consists of the following parts: (1) A starting valve; (2) a reducing valve; (3) a check valve; (4) an auxiliary pipe line.

In order to operate this device the reducing valve must be set at a very low pressure—something that will not move the engine—from 20 to 35 lbs.) the dimensions of the cylinder to govern. When the engine is placed on the train the

the steam chest. For each and every stop or drift made by the engine when throttle is closed and the pressure on the steam chest side of check valve becomes less than pressure on the reducing valve side of check, this valve will raise and allow the auxiliary pipe pressure to pass to the steam chest and cylinders, thereby preventing the induction of smoke box gases and cinders; avoids vacuum, friction and the carbonization of oil; cools the cylinders; prolongs the life of metallic piston rod packing and crossheads and eliminates the pound in main boxes and in rods while

perheated steam. Too often the trouble experienced with similar devices is that they fail to deliver a sufficient amount of steam in the cylinders to prevent vacuum, while drifting at a high rate of speed due to the fact that they choke the admission ports. This trouble is remedied in the Wyman device in that 1½ and 2-inch pipe line is used, which puts a large amount of steam there, when engine is drifting at high speed and absolutely prevents vacuum. This in turn will cure all other defects referred to above, and has been found eminently successful.

**Air Pump Lifter.**

By E. L. BOWEN, Air Brake Foreman,  
McComb City, Miss.

The accompanying drawing shows the details of a substantial lifter for the New York air brake No. 5 pumps. As shown, it consists of a cross beam and two loops of wrought iron that pass over the valve cage bosses on each side of the air cylinder. The two ¾-in. set screws are screwed up into the depressions in the bottom of the lower valve cages, thus fastening the lifter securely to the pump. The use of this device, which is easily and cheaply constructed, is much superior in every way to the common practice of lifting the pumps by the use of a chain. As is well known, the liability of chains to slip on cylindrical surfaces is very great, but with this device properly fastened to the pump there is no possibility of it slipping, thus making it absolutely secure in placing the pump in position or removing it from the engine. Hence it may be classed as at least a small step in the popular direction of Safety First, as it is always reliable.

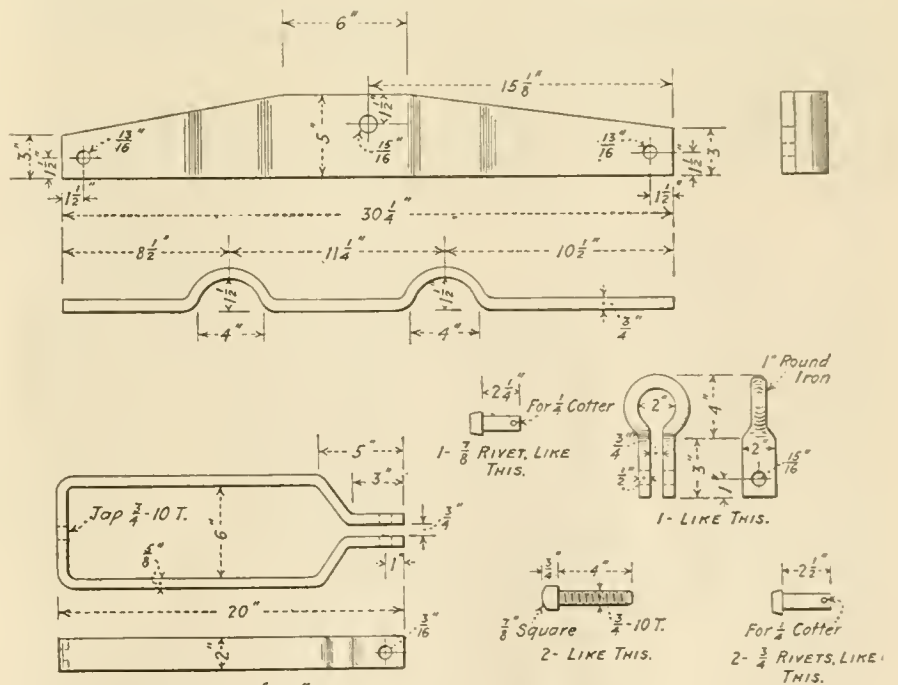

2- LIKE THIS OF 7/8 x 2" IRON.

DETAILS OF AIR PUMP LIFTER.

### Driving Spring Puller.

By HARRY BOHAN, PROCTOR, MINN.

The accompanying photograph and drawing show a shop made spring hook. In applying the device the driving wheel is first run up on an iron wedge, and then blocks are placed under spring equalizers or rigging. The engine is then moved off the wedge, and the hook put into place as shown. The spring is then pulled down and the clips removed, then slacked back and the spring removed. The new spring is then pulled into its place in the



DRIVING SPRING PULLER DEVICE.

same manner. Sometimes it may be necessary to place an iron bar between the wheel and spring to prevent the spring from being pulled over sideways. The hook works best when the engine is moved by its own steam, and the operation can be easily completed in about twenty minutes. For the largest type of locomotives, the hook should be made of 3 inch square iron. It has proved itself a labor saving device here, and at little cost would prove equally effective elsewhere.

### Poets Inventors.

An inventor is generally looked upon as a hard-headed, matter-of-fact person, with none of the celestial fire that produces the great works of poets and immortal writers. Yet a little reflection will convince thoughtful people that the mental attributes which produce the works of a Milton, a Shakespeare, or a Burns, are similar to the mental forces which have invented such triumphs of ingenuity as the printing press, the steam engine, the electric dynamo, the locomotive engine, the telephone and the railway air brake.

On reflection it will be found that mechanical invention differs nothing from

that which gives value to those pursuits considered to be more mental and refined. Homer and his Iliad, Virgil and his Aeneid, Milton and his Paradise Lost, Burns and his Tam o' Shanter, were minds and productions of the same fiber and tension with newer men, and Watt with their engines, Huyghens with his watch, Arkwright with his spinning jenny, Brama with his hydraulic press, Hedley with his locomotive, Westinghouse with his air brake. In fact, all observation shows that the power of combining machines and constructing powers, in the heroic or any other line, are usually united in the same individual, that all poets are mechanical inventors and all mechanical inventors are poets. Hooke made verses as well as machines; and when he presented thirty-seven different projects for flying, had his attention been directed to express his thoughts in meter, he had previously shown a facility for describing the glories of his mistress' eyes in as many sonnets.

Lord Worcester also made verses, and his "Century of Inventions" has been commented upon by more than one person, as if it were a poem, although not written in rhyme. Arkwright was famed among his customers for a light hand and exquisite edge on verses which cut as keen as a razor. Watt, in his youth, was a rhymester, and few men in his generation read more fairy tales and poetry. Few who knew Rennie, near the close of his life, would have dreamt of finding under the inflexible man of business exterior an enthusiastic admirer of poetry and music. Telford, when building rough stone walls as a working mason, was an esteemed contributor to the Poet's Corner of the Scotch Magazine, and his productions were imbued with much of the poetical sweetness of the Bard of Ayr.

### Saving and Waste of Coal.

We once heard a road foreman of engines who was hiring a new fireman say: "The engineers will instruct you in most of your duties, but your first duty will be to keep the boiler hot."

We considered that to be shortsighted advice, and its principles have been the means of throwing millions of dollars' worth of property into the air. The extent of waste through steam screaming through safety valves is so indefinite that few persons realize its magnitude. The writer years ago made a series of tests to find out the waste of coal due to safety valves blowing, and he discovered that every minute the safety valves were blowing the equivalent of twelve pounds of coal passed into the atmosphere.

The authorities of Purdue University carried out some carefully conducted tests, to demonstrate the extent of waste due to safety valves blowing off steam

for four consecutive minutes. They found that six cubic feet or 336 pounds of water was converted into steam and blown away at the rate of 84 pounds of water per minute.

Combustion is the result of the chemical union of carbon with oxygen at a high degree of temperature, thereby producing light and heat. It is the duty of engineers by knowledge and intelligence to see that this process is carried out effectively. One unit of heat equals about 778 foot pounds of work, or 778 pounds raised one foot high. The perfect combustion of 10 pounds of coal, which is about one shovelful, gives about 140,000 units of heat and will raise 778 pounds 100,000,000 feet high. The raising of 33,000 pounds one foot high per minute is one horse-power, therefore the loss through this pop of one shovelful of coal equals a waste of about 4 horse-power.

Practically it is impossible to obtain as good results as these figures indicate, on account of leaks and other sources of waste, but much can be accomplished by careful men.

### Water Circulation in Boilers.

Several years ago the Chicago, Burlington & Quincy Railroad people made a series of exhaustive tests to find out the temperature of locomotive boilers under varying conditions that ought to be better known to railroad men generally than they are. The experiments were made to determine the temperature of the water in various parts of the boiler when the locomotive was standing, no steam being used from the boiler excepting as required for operating the injector. The results of the experiments indicated that when the feed is delivered in the usual manner to the boiler, the water in the water-leg on the opposite side may have a temperature 100 degrees less than the normal temperature of the boiler, and that the intermixing is greatly improved by using a perforated pipe extending beyond the check within the boiler either longitudinally or transversely, and also by the omission of a pipe, and by means of an orifice that opens upward. In the progress of the tests it was found also that when the intermixing was most complete, the drop in steam pressure was greatest, so that it may almost be said that the degree of intermixing in any given boiler may be judged by noting the rapidity with which the steam pressure falls under the action of the injectors when the engine is at rest.

It is likely that the conditions described could be very much modified by the action of a superheater, but we think that any means used to promote circulating the water would have beneficial results on fuel economy and experiments should be encouraged.

### Lehigh Valley Seventy Years Old.

The Lehigh Valley Railroad Company is 70 years old. Its original charter bears the date of April 21, 1846. The Pennsylvania Railroad Company was 70 years old on April 13, and is, therefore, about a week older than the Lehigh Valley. Both roads are thriving very well at threescore and ten.

A small part of the Lehigh Valley Railroad, as it now exists, really had its start 86 years ago, however. On April 7, 1830, the General Assembly of Pennsylvania authorized the Beaver Meadow Railroad and Coal Company "to construct and make a single or double railroad from the Beaver Meadow coal mines, in the county of Northampton, to a convenient point on the River Lehigh, at any place above Mauch Chunk." The Beaver Meadow Company was merged into the Lehigh Valley Company on July 8, 1864. Its line extended from Mauch Chunk to Penn Haven, thence to Beaver Meadow and adjoining coal mines.

The Lehigh Valley Railroad was at its beginning incorporated under the name of the Delaware, Lehigh, Schuylkill and Susquehanna Railroad Company by an act of the Pennsylvania Assembly. The first survey of the line was made between Easton and the mouth of Mahoning Creek, five miles east of Mauch Chunk, in 1850, and on March 10, 1851, the construction work was begun near Allentown. The name Lehigh Valley Railroad was formally approved by the General Assembly as a substitute for the longer one on January 7, 1853. It was originally intended that the line should extend from Easton to Mauch Chunk. By June 11, 1855, it had been opened as far as Allentown from Easton, and it reached Mauch Chunk September 12, 1855. By 1869 the line had been extended to Wilkes-Barre, being opened for traffic on May 29 of that year. In 1875 New Jersey was crossed to tidewater at Perth Amboy, N. J., and in February, 1891, a new line headed toward New York was opened to Newark. The same year the company's rails into Buffalo were opened for traffic. A year later Jersey City and New York harbor had been reached.

### Soft Metal Hammers.

In the general working of an engineering shop it is often desirable to hammer or strike objects without bruising them, and to do this either a piece of soft metal must be placed between the metal struck and the ordinary hammer, or a hammer made of soft metal must be used. Such hammers must necessarily be of some heavy metal, copper, brass, lead, and lead hardened with from 10 to 15 per cent of tin, often being selected as they combine ponderosity with softness. The shape of the hammer depends on its

purpose, as also does its size, but all are heavier than steel bulk for bulk. For use on iron and steel, brass and copper answer well, while for other metals lead, either hardened or soft, is efficient bruising being prevented by their use. It is always necessary that hammers be well balanced, and it is good policy to turn up the working faces smooth, as the skin on cast articles is always harder than the clean metal underneath.

### Hardening and Tempering.

Our contemporary, the *Blacksmith*, says that such tools as drills, chisels and punches are frequently hardened and tempered with one heating only. For hardening, heat to a dull red, and cool the point in water for about  $\frac{1}{2}$  inch up; then, for tempering, rub bright with a piece of sandstone, and watch for the temperature of the point to be raised by the heat of the shank; the temperature will show itself by the different colors as follows: Light straw, straw, deep straw, light purple, purple or plum color, deep purple, light blue, blue, deep blue. These colors represent different degrees of hardness, and this is where the practice comes in, to know what color or degree of hardness is suitable for the work. When heating the point of a drill or chisel, one part of it (the thinnest part generally) may assume a very light orange color, while the other part is a dull red; and if cooled out while in this condition, it would be impossible to get an even temper; thus the necessity of getting a uniform heat, which means practically that the tool must be got either a dull red or dark or light orange all over before being cooled.

A punch or drill may, for certain purposes, require to have a very hard point and a tough shank or shaft. Having hardened the tool by quenching from a cherry red, the tool may be reheated from the shank end to a low temperature, closely watching the color as it approaches the cutting edge. Immediately the point assumes a light yellow, quench in oil or water.

It is convenient to heat small tools for hardening in an iron pipe about 1 foot long and 2 inches in diameter, with one end closed by means of a wrought iron plug welded in. The tools are placed in the pipe, which is thrust into the fire; and when the proper temperature is attained, the pipe is removed from the fire and the tools are tipped into the quenching medium. When cool, they will be found to be clean and ready for tempering, which may be done by placing them on an iron plate, heated over a gas stove. Small round punches should be rolled over the hot plate until the required color appears, while small dies are best placed endwise on the plate so that the heat travels up from the bottom;

when the cutting end or face is a straw color the back will probably be blue, and this will be an advantage, as it is only the cutting end that is required very hard.

### Mahogany.

Mahogany is not only a fashionable wood but it is the most reliable wood known to general construction. It is unequalled for doors, house trimming, furniture or for any purpose when a hardwood is desired.

It does not warp or check; neither does the sun fade it; but on the contrary, it brings out its rich color. Time, which destroys other woods, only serves to increase the value of mahogany.

Mahogany is found in the West India Islands, also in Mexico. Some time between the years 1521 and 1540, Cortez and his companions after their conquest of that country, used mahogany in the building of the ships in which they sailed on their voyages of discovery. The color of mahogany when freshly cut is of a light tone, and in finishing it this shade should be preserved. The finisher should not be permitted to use any stain upon the wood, as this detracts from its effect and interferes with one of the most beautiful operations in nature. The owner of a house finished in mahogany may notice from month to month the deepening shades of color in the wood, which mellow in the sun's rays and take on a richer glow. This increases year by year until the wood is resplendent in beauty.

To stain such wood is a vain attempt to improve upon nature, and by it the changes in shade and variety in tone of color are destroyed.

### Too Suggestive of the End.

Some time ago a lodge of locomotive firemen rented their meeting hall to the Order of Elks. Recently the boys bought a "Hoodoo Model" and asked the old Elk where they could put it. He told them to put it into the banquet room, but to cover it with a case so that it would not be injured.

The carpenter employed to make the box designed it to take up as little room as possible. When it was set up and painted black, it looked like a coffin set upon legs. A few days after it was in place, the Order of Elk sent for the Secretary of the lodge and asked what in the name of the everlasting properties, he meant by permitting a casket to be set up in the lodge room?

The Old Elk explained that they tried to hold a banquet after initiation, in the room the previous evening, but the boys could not enthuse with that thing staring in their faces, making the place as solemn as a church; so the lodge voted that I tell you to remove the remains or get another hall. We don't want a vault.

## Department of Questions and Answers

### HELICAL SPRINGS.

J. B., Toronto, Canada, asks: What is the rule used in finding the strength or carrying capacity of a helical spring? A.—The common rule is to multiply the ultimate tensile strength of the steel by .3927 and the product again multiplied by the cube of its diameter, and divide by the difference between the outside diameter of the coil and the diameter of the steel.

### DEFECTIVE INJECTOR.

R. M., Plymouth, Pa., writes: In testing a lifting injector that fails to lift the water properly, what may be the general causes of its failure? A.—There may be a leak in the steam valve, and the suction pipe may be heated to such a degree that it may prevent the formation of a vacuum in the pipe. The steam valves should be perfectly tight. A leak shows by an escape of steam when the steam valves are closed. There may be a leak in the suction pipe or its connection, in which case air is admitted and a vacuum prevented. A leak of this kind may be detected by closing the heater cock and opening the main steam valve only, if there is a separate lifting jet, or with a single lever instrument, by opening both steam valves at once. The steam blowing back to the tank will then escape through the leak, if there is a leak. The trouble may be remedied by tightening up the suction pipe connections. A leak in the check valve will also heat the suction pipe and cause a defect. The check valve should be tight.

### SUPERHEATED AND SATURATED LOCOMOTIVES.

J. M., Elkhart, Ind., writes: To settle a dispute here kindly advise us whether a superheater locomotive will start a heavier train than one using saturated steam. A.—No. The mere addition of heat to the steam does not increase the mean effective pressure in the cylinder. The pressure against the piston is the same in both cases, and consequently the superheater locomotive will not start any heavier train than will a saturated locomotive of the same size operated under the same conditions. It will, however, pull the same train at a considerably higher speed. Generally speaking, the tonnage rating of the locomotive is not based on the number of cars that the locomotive will start, but upon the number of cars that it will haul at a given speed. It may be added that by the use of highly superheated steam the boiler capacity is increased in proportion to the saving in water obtained, which amounts to from 25 to 35 per cent. By reason of this increased boiler capacity the superheater

locomotive can be operated at longer cut-offs, thereby developing higher speeds with the same tonnage as the saturated locomotive of the same dimensions, or it will haul heavier trains at the same speed. This higher performance is done with less coal and consequently does not increase the work of the fireman.

### SIZE OF BRAKE VALVE EXHAUST PORT.

C. F. S., St. Louis, Mo., writes: Will you kindly advise what the maximum opening is through a Westinghouse 11-6 Brake Valve in emergency position, also in full release position. Is the size of these openings the same as the G-6 Brake Valve? A.—The size of the ports that control the flow of air from the main reservoir to the brake pipe with the brake valve in release position, and the ports that control the flow of air from the brake pipe to the atmosphere for an emergency application of the brake, are of approximately the same size and are of the same size for both the 11-6 and G-6 brake valves. The size of the port in area is about one third of a square inch. This should not be construed to mean one third of an inch square.

### BROKEN BRAKE PIPE.

E. M. B., Sedalia, Mo., writes: How would you proceed to bring a train of freight cars to the terminal if the brake pipe on the locomotive is broken off between the brake valve branch and the hose couplings at the rear of the engine, there being no signal pipes on the engine or tender. I have recently heard of connecting the brake cylinder pipes on the locomotive (E. T. equipment) with the brake pipe on the tender to keep the brake pipe on the cars charged with air, so will you please explain how the brakes are operated under such a condition?

A. In such an event it would be possible to carry the automatic brake valve handle on lap position, close the stop cocks in the brake cylinder pipes on the engine, couple the brake cylinder hose with the brake pipe hose between the engine and tender, screw down the safety valve of the distributing valve several turns, place the independent brake valve in slow application position and adjust the reducing valve to 70 lbs. or any pressure desired in the brake pipe.

The distributing valve will then admit main reservoir pressure into the brake cylinder pipes on the engine and cross over into the brake pipe at the rear of the engine and charge the brake pipe and auxiliary reservoirs. In this manner the system may be maintained charged and if an application of the brake is desired, the independent brake valve may be moved to release position, opening the application

cylinder to the atmosphere which will exhaust pressure from the brake pipe and result in an application of the brakes on the train. You will understand that this is merely an emergency brake and an emergency application is very likely to occur as the brake pipe is opened through a  $\frac{3}{4}$  inch opening, and again the distributing valve must perform the work of a feed valve and as it cannot be expected to be as sensitive in supplying leakage from the brake pipe, there is a chance of brakes sticking if the brake pipe leakage is sufficient to apply them. We rather favor this method, although the brake pipe may be charged under such conditions by removing the equalizing piston and slide valve from the distributing valve and unscrewing the return spring casing screw in the independent brake valve and placing this brake valve in quick application position adjusting the reducing valve and safety valve as previously suggested.

There is however nothing new involved in such temporary arrangements as an article on page 462 of the October, 1907, issue, written by G. W. Kiehm, explains both of these methods of procedure in the event of broken reservoir or brake pipes and was written with reference to the No. 5 E. T. equipment before the No. 6 E. T. equipment was in use.

### IMPROVED FEATURES IN BRAKE EQUIPMENTS.

J. H. B., Newark, O., writes: (1) Without going into any technical details, will you please tell me what are the actual improvements of the E. T. locomotive brake over that of the combined automatic and straight air brake? (2) What are the actual improvements in the U. C. pneumatic brake equipment over the L.N. equipment?

A. (1) The one feature that alone justifies its adoption is: a uniform brake cylinder pressure is obtained and maintained against leakage regardless of piston travel during a service application which is something that was never before attained with an air brake on a locomotive. If the engine is the second one of a double header or from any engine in the train the brake can be applied and released independently without in any way interfering with the train brakes. The brake contains all of the features of the high speed brake and the combined straight air and automatic with considerable less apparatus and piping, to say nothing of its being adapted to all classes of service without change and with one size of distributing valve, and the brake on the locomotive can be graduated on or off with the automatic brake valve.

(2) The principal improvements in the U. C. brake that are not found in the L.

N. equipment are, protection against the operation of brakes as a result of light variations in brake pipe pressure resulting from leakage and imperfect feed valves, release of brakes positively assured upon a movement of the operating valve piston, a uniformity in rise of brake cylinder pressure upon an application following a release of brakes or an application during a graduation of release, a more perfect graduated release due to the proportion of the quick recharge and auxiliary reservoirs, full emergency pressure obtainable any time after a service application and an improvement on the release of brakes after an emergency application. This brake contains all of the improved features of the L. N. equipment at the same time and more refined safety and protective features. In addition to this the valve is built up in a manner that certain features may be used or eliminated at will, that is any feature from the plain triple valve to the most improved type of brake may be used by substitution of parts and when desired an electric portion may be added and the valve operated electrically, and in either case, service and emergency functions are separated.

#### IMPROVEMENTS IN UNIVERSAL VALVES.

W. M., Harrisburg, Pa., writes: (1) Will you kindly explain through the columns of RAILWAY AND LOCOMOTIVE ENGINEERING, what the object was in adding a ball check valve to the high pressure cap of the distributing valve near the protection valve cap? (2) Why was the spring placed between the quick action piston and the piston chamber cap in the latter types of valves?

A. Some trouble was experienced with the former types of valves on account of the emergency pistons becoming bent in service, which sometimes resulted in undesired quick action and sometimes in a failure to obtain quick action when it was desired, that is, on a single car which did not affect the triple valves or other universal valves in the train so far as containing the emergency application was concerned. Upon an investigation it was discovered that the emergency pistons were being bent on account of the brake pipe pressure entering the emergency piston chamber too rapidly, which under certain conditions resulted in throwing the emergency piston against the abutment at the release end of the cylinder with such force as to bend and otherwise damage the emergency pistons. In order to overcome this it was decided to charge this emergency piston chamber through a 1/16 in. port so that the increase in pressure would be considerably slower, but at the same time it was recognized that the 1/16 in. opening would not be large enough to permit of a sufficient flow from the emergency piston chamber to insure an emergency applica-

tion when desired, so the ball check valve was adopted for the purpose of preventing a flow to the back of the emergency piston other than that through the 1/16 in. opening, but readily permit of any desired amount of air pressure or volume to pass from the back of the emergency piston when an application of the brake is desired. Thus the ball check valve merely prevents brake pipe pressure from passing through it to the emergency piston chamber, but permits of a large opening from this chamber to the brake pipe.

(2) The object of the spring in the quick action piston chamber is to hold the quick action piston against the quick action valve so that the piston could not strike the valve the blow that was possible without the addition of the spring. Without the spring, the piston would remain at the lower end of the chamber, and when a quick action application was made the distance between the valve and the piston permitted of a blow of considerable force when the piston struck the valve which sometimes resulted in damage and unnecessary wear of the piston. With the spring in this space the motion between the piston and valve is eliminated. Both of the changes mentioned in the universal valve have accomplished the purpose for which they were incorporated.

#### LIMITS OF BRAKE VALVE GEAR.

A. H., Wheeling, W. Va., writes: Will you please tell me what is the limit of wear of the rotary valve and seat of the H-6 brake valve before these parts are worn out, and kindly state why the limit has been placed upon the amount of metal that is to be removed before a valve or seat is to be scrapped?

A. The combined amount of metal that may be safely removed from the valve and seat is 1/8 in. The distance from the top of the rotary valve to the base of the seat when the parts are new is 1 1/2 in. and when this distance is reduced by wear, grinding or facing off to less than 1 3/8 in. either the valve or seat must be renewed. The original thickness of the rotary valve, from the face to the upper outside edge, is 7/8 in. and from the top of the seat to the base 5/8 in., which permits of the removal of 1/16 in. each from the valve and seat. Some instructions insist that not more than 1/16 in. is to be removed from either part, but if there are no definite instructions the work may be handled by changing the parts from one valve to another. As an example, suppose that both the valve and seat are worn say 1/32 in. below the condemning limit, the old valve may be placed on a new seat and the old seat may be used with a new rotary valve and both brake valves will have this minimum required distance and 1/32 in. to spare. The latter

is merely a suggestion, as the valve and seat should not be reduced more than 1/16 in. each as it permits of too much lost motion between the rotary valve and the key.

The reason for the limit to wear is, the rotary valve key has a 3/8-in. engagement in the valve, the thickness of the rotary key gasket when new is about 1/8 in. and if 1/8 in. is removed from the valve and seat and the rotary key gasket is entirely worn out before it is discovered, the key will have but 1/8 in. engagement in the rotary valve. If the distance was to be reduced beyond this point there would be a possibility of the valve becoming disengaged from the key when the rotary key gasket is practically worn out and such an occurrence might result in an accident.

#### About Belts.

One of the most common mistakes made in putting up new belts is in getting them entirely too tight. New belts stretch a good deal for a time after being put in use, and unless they are made very tight at first soon require taking up; so they are usually put up as tight as possible, regardless of the fact that this excessive tension pulls the belt into short crooks, destroys its elasticity, injures the machine on which it runs, and is very wasteful of power. A new belt should be put on as loose as possible, and then be taken up as it becomes really necessary. A man of judgment and experience should be placed in charge of belt management. Much loss is occasioned by the inexperienced in the care of belts.

#### The Art of Nail Driving.

A superannuated master car builder, who was recuperating in our office one day, remarked: "Theories are very good in their place, but they do not teach a person how to drive a nail. Nothing but practice will do that, and even practice without the proper thought will fail to accomplish it. You must have both combined. When you drive a nail into a board, what do you do? Do you trust to luck that the swinging hammer above your head shall come down on the right spot? Do you concentrate your thoughts on the hammer circling in the air? No. You concentrate your thoughts and eyes square on the head of the nail you want to hit, and no matter where your hammer is or what course it describes in the air, if your intense thought is on the spot where the blow should fall, then there it will fall. If your thoughts wobble and are uncertain, you will miss the nail or drive it sidewise.

Do not adopt the woman's way of holding the nail between your fingers, for then your fingers are liable to get bruised.

# Railway and Locomotive Engineering

A Practical Journal of Motive Power, Rolling Stock and Appliances.

Published Monthly by

**ANGUS SINCLAIR CO.**

114 Liberty St., New York.

Telephone, 748 Rector.

Cable Address, "Locong," N. Y.  
Glasgow, "Locoauto."

**Business Department:**

ANGUS SINCLAIR, D. E., Pres. and Treas.  
JAMES KENNEDY, Vice-Pres.  
HARRY A. KENNEY, Secy. and Gen. Mgr.

**Editorial Department:**

ANGUS SINCLAIR, D. E., Editor.  
JAMES KENNEDY, Managing Editor.  
GEO. W. KIEHM, Associate Editor.

**London Representative:**

THE LOCOMOTIVE PUBLISHING CO., Ltd.,  
8 Amen Corner, Paternoster Row, London, E. C.

**Glasgow Representative:**

A. F. SINCLAIR, 15 Manor Road, Bellahouston,  
Glasgow.

**SUBSCRIPTION PRICE**

\$2.00 per year, \$1.00 for six months, postage paid in the United States, Canada and Mexico. For other parts of the world, \$2.50, or ten shillings. Single copies, 20 cents. Remit by Express Money Order, Draft, Post Office Order or Registered Letter.

Mailing address can be changed as often as necessary—always give old and new address, and if you subscribe in a club, state the name of the agent.

Please give prompt notice when your paper fails to reach you regularly.

Entered at the Post Office, New York, as Second-class Mail Matter.

**Intelligent Care of Boilers.**

The modern tendency of steam engineering is to employ increasing pressure on boilers, for the purpose of obtaining the greatest possible amount of useful work in return for every pound of fuel consumed. In all lines of steam engineering, progress appears to be in the direction of higher pressures, but locomotives still maintain the lead. There are few new locomotives now coming out that carry boiler pressure of less than 200 pounds to the square inch, and still higher pressures are not uncommon. As the most economical steam engine, all other things being equal, is that which takes steam into the cylinders at the highest possible temperature and lets it escape

at the lowest, making the greatest difference in the temperature by converting the heat into work—there is a decided advantage in employing steam of high tension; but the practice is not without its drawbacks. With the defective expansion gear used on the best of locomotives, the margin of saving between an engine carrying very high and one carrying moderate pressure is very limited.

Although the locomotive boiler is higher pressed than any other form of boiler in general use, and, although the type is more numerous in America than any other form, it has an enviable reputation for causing few violent accidents. This is particularly remarkable considering the admitted fact, that the locomotive boiler is subjected to harder usage from sudden changes of temperature, from bad feed water, from exposure and shocks of service than any other boiler in use.

The immunity of locomotive boilers from violent explosions reflects the highest credit on the mechanical departments of our railroads, for it is due to the enlightened care in design and construction, and to unceasing vigilance in maintenance, handling and management. The greater the margin of safety with which a boiler is constructed, the easier will it be maintained in safe working order. The tendency of intense pressure now become the rule is to reduce the factor of safety which has never been high. If this tendency results in increasing violent explosions of boilers, the saving resulting from high steam pressure will prove a costly way of making money.

The Railway Master Mechanics' Association has directed persistent and intelligent attention to everything relating to the proper design and maintenance of locomotive boilers. Committees have made emphatic reports recommending systematic periodical inspection of boilers, so that any dangerous weakness may be discovered in time to apply the proper remedies. They recommend a hot hydraulic test to be made on boilers every six months after they are more than two years old, and careful inspection during the test to detect any change of form that may indicate any weakness. They also recommend weekly inspection with the hammer test for broken stay-bolts. The adage of one man being able to take a horse to the water when ten cannot make him drink, applies directly to the way many committee reports are treated. A committee can make the very wisest recommendations; but all the persuasion in the world will not make some superintendents of motive power and master mechanics act on them. We know of no committee's recommendations more important to the safe operating of railroads than those referring to the inspection of locomotive boilers, yet there are no re-

ports more flagrantly neglected. The most serious menace to the safety of a locomotive boiler is broken stay-bolts, and yet it is a common thing when an engine goes into a shop for general repairs to find from ten to twenty broken stay-bolts on one sheet, and that on roads where regular inspection of stay-bolts is reported to be carried out. A mere hammer test is a very uncertain way of detecting a broken stay-bolt; but if it is supplemented by a carefully conducted hydraulic test, any serious defect will nearly always be identified. Some master mechanics object to hydraulic tests, and say they are useless and dangerous. When this is true it is not the blame of the method, but of the men applying it. Unless tests of any kind are properly conducted they had better be omitted, for a perfunctory test that is a mere form tends to give danger the appearance of safety.

**Beauty in Machine Design.**

One of our friends, an accomplished engineer, remarked on looking over a fine new machine tool, "A thing of beauty is a joy for ever" and his remark was sneered at by a shop foreman, who boasted himself as "a practical man, first, last and all the time." An impression prevails among many ignorant mechanics that beauty of form and utility cannot go together. That is prejudice resulting from ignorance and defective mental training.

It is not necessary that we should have the intellectual apprehension of the fitness of anything for its use, in order that we shall see the sense of harmony and regard the object as beautiful. But in any case we do have the sense of harmony and regard the object as beautiful. But if in any case we do have the perception of fitness, then this perception must be satisfied, or else the object cannot appear beautiful.

Machinery, where, as in the case of architecture, man is himself the creator, affords admirable illustrations of the same truth. Here we are able to see with peculiar distinctness the necessity for harmony if anything is to appear beautiful to us. The illustrations of these truths that may be drawn from machinery possess an especial force and value, because here all uses lie within our comprehension, and the fitness of every part of any machine, and of the machine as a whole, for its use, can be determined in an unmistakable manner. Every machine has its special use. This use was proposed by its constructor, and he has made all the adaptations of the several parts and of the whole of the mechanism to its accomplishment, and the degree of success or failure is a matter of certain observation to the instructed mechanical engineer, no mechanical forms or pro-



portions can appear beautiful unless a good mechanical reason can be given for them. These forms and proportions are always the most graceful and elegant that most completely fulfill mechanical requirements. We are able to see at once that the pleasure which the builder of a machine can derive from the contemplation of his work, all the beauty that it can possess in his eyes, depends wholly upon his perception of its fitness for the use for which it was designed.

In the earlier days of machine construction, before the construction had become a science through study of its underlying principles, it was the custom to employ architectural forms, those being the forms with which designers of machines were already acquainted and very beautiful these adaptations of classic and Gothic features were thought to be. As, however, the unfitness of these forms to resist and transmit mechanical stress, and to perform the various functions which are demanded came to be perceived, and the necessity for entirely new forms designed to meet a new class of requirements, and for freedom in such new designs, untrammelled by the attempt to retain old forms in any degree, came to be realized, how rapidly and how utterly did all the once fancied beauty of classical forms in construction disappear.

#### Faults of the Steam Engine.

One of the first discoveries usually made by technical students of steam engineering is the fact, that as a means of transforming the latent energy of fuel into mechanical work, the steam engine is an extremely wasteful apparatus. Scientists have found that one pound of good coal represents about eleven millions of foot pounds of energy. Very few steam engines develop one million foot pounds of work for each pound of coal used in the furnace, and engines utilizing 10 per cent. of the coal are considered thoroughly first class. On first inspection this percentage of waste seems enormous, and the novice readily concludes that mismanagement must be responsible for a great portion of the wasted energy. But increase of knowledge gradually brings a realizing sense of the tremendous difficulties that obstruct the way of radically increasing the efficiency of the steam engine.

There have been a great many prime motors invented for the purpose of converting the latent energy of carbon into mechanical work, and several of them like the gas engine have been capable of utilizing a greater proportion of the heat energy of fuel than the steam engine, but none of the improvements have been considered so reliable for everyday work as the steam engine, so with all its shortcomings and defects, the steam engine continues to be popular with power users who find it important that their machin-

ery be kept running day by day without interruption. In popular addresses we are continually hearing the prediction made that science will soon lead the way to effecting radical improvements upon the steam engine. Past achievements of science in this direction have been exceedingly slender, and do not make the promises for future achievements very encouraging. The practical man, on the other hand, whose labors have done most toward developing and perfecting the steam engine, and whose opinions regarding future progress are entitled to the highest consideration, believes that the limits of possible economy have been nearly reached.

Although a steam engine that converts 10 per cent. of the potential energy of fuel into mechanical work may be regarded as a wasteful machine, it is not wasteful when compared with the great mass of engines running our railroad trains and our mills, for very few of these utilize more than 5 per cent. of the heat stored in the fuel used. The opportunity for railroad engine improvement at the present day appears to be in carrying out methods which will bring up the performance of the common five per cent. engine towards the high class engine that takes 10 per cent. dividend out of the coal. The men who busy themselves with this problem may safely leave to others the work of improving what is now regarded as the high class engine. The great amount of waste with all steam engines is the exhaust steam, and there is no probability that the loss of heat passing out by this channel will ever be radically decreased while steam is employed as a mode of motion. There are, however, lines of economy that may be worked on to advantage by our locomotive engineers. Numerous minor causes of waste could be closed up by intelligent management and the resulting saving would materially increase the economy of the engine. The most hopeful of these is the general introduction of steam superheaters, which are as effective in preventing the waste of heat through wet steam.

#### Over-working Passenger Cars.

At the last mechanical convention, we heard a superintendent of machinery telling of a group of passenger cars his company had bought a few years ago, and not one of them had been taken into the shops for two years. That was a highly creditable record for those cars, but we doubt the wisdom of running them that length of time without taking them into the shops for temporary repairs. Our impression was that it would have been better policy to have those cars taken in after six months service, to have the rods and bolts tightened, cracks in joints stopped and other precautions of a similar

kind taken on the principle that a touch in time saves nine.

When cars are built of timber which has not had a long and thorough seasoning an overhauling is necessary after a few months train service. This refers to wooden cars. Steel cars may stand different treatment which time will demonstrate.

But to return to the treatment of wooden cars which will be in the majority for years to come, when seasoning-cracks in paint and varnish are closed, the trucks taken out and all looseness due to shrinkage remedied, the car is better fitted to run two years or more without coming into the shop than it was to run a year when first completed.

If the history of some of the oldest cars in service could be traced, it would be found that they had been well cared for at first. The life of a car is almost unlimited if the joints can be made weather-tight, the frame kept dry and the slack of rods, braces and trusses taken up as fast and as often as shrinkage makes it necessary. While these things are generally understood, they are too frequently neglected, and the result is great loss to the owners. Cars which should be sound and strong in their frames for twenty years, frequently get out of shape in half that time. The real cause for this is neglect to keep the frame dry and the nuts and trusses tight.

#### Aristocratic Railway Men.

The promiscuous condition of American individuality inclines us to ignore all ideas of the influence of heredity. Most of the officials who hire railway men pay attention only to a candidate's physical outline and requires that he has had a fair common school education.

We have found at times railway managers who were inclined to look deeper into the history of the people they hired. The late C. J. Ives, president of the Burlington, Cedar Rapids & Northern Railway had peculiar views concerning the men he was willing to hire for responsible positions in his company, and his selections certainly indicated good judgment.

In a conversation the writer once had with Mr. Ives he was surprised to hear the general manager express himself concerning heredity that seemed like expressions of an aristocrat. Referring to one person, he said: "Richard has not made a shining success, but his work has been away above the average, as I knew it was certain to be. He comes from ancestors who have made their mark on New England affairs. He owes much in one way to his father and mother, for they were no common people. His grandfather was for years a power in Rhode Island. Of his remote ancestors I know nothing, but you may be certain

they were influential in their generation if they were merely carpenters or blacksmiths. They were likely thinkers and workers in their own sphere of activity, the kind of people who stood up for human freedom in the days when the United States was in the making."

#### Deficiency of Science in Workshops.

Industry, activity and quick perception are valuable helps in the making of a first class mechanic, but they are not all sufficient if the man is ambitious to be a leader in his calling. Without some knowledge of mathematics and mechanics he will never advance beyond the practical application of a few rules and principles, and he will often be driven to very circuitous methods, at a great waste of material, in arriving at results which could be obtained more easily and more readily by scientific methods. Most persons engaged in mechanical arts can read and write; they understand the use of tools, but they have never received the special instruction which enables a man to understand the reason of things. Their muscles have been strengthened by labor, but their minds have not been disciplined by knowledge. Many mechanics possess considerable inventive ability, which frequently leads to speculations which terminate not only in their disappointment but in loss to others. If the ability which exists to a large extent in our workshops were only directed by some mathematics and mechanical knowledge it would frequently lead to more important results than are now achieved.

#### Selecting a Shop Foreman.

An honored correspondent recently submitted to us the perplexing question, "How would you select a machine shop foreman?" We have given this question considerable thought not only now but in years gone by, and we are not priding ourselves on our readiness with a proper answer.

The selection should be made from the shop force, and from those who recommend themselves by being active, energetic, conservative but progressive, with good moral character. We prefer selecting from the older men if their qualifications are satisfactory. In qualifications considerable knowledge of figures, reading and plain writing is essential; being able to understand orders quickly. He must also possess mechanical skill and executive ability, be systematic and thorough in doing work and have the ability to impart information concerning the operations carried on in the shop. While being able to explain operations clearly he must not incline to perform them. The expression, "I would rather do the job myself than look at your unskillful actions," is expressing a very senseless sentiment.

#### Consolidating Mechanical Associations.

Every few years agitation arises in favor of consolidating the two principal mechanical associations, the Master Car Builders and the American Railway Master Mechanics Association; but there is no sentiment in the organizations in favor of the scheme. As long ago as 1904 there was so much agitation in favor of consolidation that a joint committee, representing both the associations, was formed to consider the matter, and they reported unanimously against any change being made. At last convention there was some talk about consolidation; but it turned principally upon a scheme to bring all the minor mechanical associations under control of the Master Mechanics. We cannot see what benefit would accrue to railroads by such a change, for every association will work more vigorously when controlling its own business than when it is left to be interfered with by other associations. They are all doing good work in their own lines, and we advise that they leave well enough alone.

#### The Safest Part of a Train.

A well known railroad conductor on being asked, "What part of a passenger car is the safest in case of a collision?" answered: "That part which happens to be in the shop at the time of the accident." Which was considered a witty answer.

There is a popular belief that the center of the car is not only the safest part in case of accident but is also the easiest riding location. There is no doubt of this. As for safety, if you are in the rear of the last car on a train and another train runs into the rear end, you are more liable to get hurt if you are seated near the rear end. If you happen to be in a head collision, there is nothing back of you to add force to the blow. If the car leaves the track and collides with an obstruction on a side track or elsewhere, it will not smash the rear end. If the train is thrown down an embankment there is nothing to land on top of the rear car. Then the location in the last car is the most pleasant in many respects.

#### Locomotive Not Wasteful of Heat.

An impression prevails generally that the locomotive is the most wasteful with fuel of any steam engine, that nearly all stationary engines operate with less coal per horse-power than the best form of locomotive. This is contrary to fact, for a first class modern locomotive equipped with a superheater does work more economically than the ordinary run of stationary engines, automatic engines excepted. It is on record that a locomotive belonging to the Erie Railroad made a run with a coal record of 3.5 pounds of coal per horse-power per hour, at a time

when superheaters had not come into general use. This measure of economy was extraordinary when we consider the losses inseparable to a locomotive with its comparatively short boiler, rapid combustion and great loss of heat due to exposed radiating surfaces.

#### Answer Inquiries of Committees.

The proceedings of the American Railway Master Mechanics' Association continue to increase by volume, but there is less individual work represented in them than there was years ago. It used to be the fashion for most of the leading members to answer circulars sent out by the various committees, but this very laudable fashion is falling into desuetude. This is to be regretted, for much valuable and original information was gleaned from answers sent from the various members. It is all very well to depend on committee to compile reports, but it is really the personal views and knowledge of the mass of members that counts of true value.

#### Consolidation Locomotive.

A correspondent says: "I would like to know what is consolidated in the 'Consolidation' locomotive. The names eight-wheeler, ten-wheeler, Mogul, etc., are intelligible, but I cannot see anything applicable to a locomotive called consolidation."

In reply we might explain that the first consolidation engine was designed and built by Alexander Mitchell, master mechanic of the Lehigh and Mahanoy Railroad. About the time the engine was completed the railroad named was consolidated with the Lehigh Valley Railroad and the name "Consolidation" was given the engine to honor the event.

#### Train Resistance.

At the last Railway Master Mechanics' convention Dr. Angus Sinclair, who has devoted much careful study and far reaching experiments to the subject of train resistance, said:

"The practice of rating the loading of locomotives according to their theoretical power has become so common that the various resistances which have to be overcome in hauling trains of all kinds at varying speeds over all kinds of tracks ought to be better understood than they are at present."

Until a few years ago what was known as Clark's formula was universally used in calculating train resistances. Kinnear Clark, the author of that formula, was a Scots railway engineer, who made many experiments with British locomotives and trains, the results having been made public in his well-known book on railway machinery published about 1855.

According to Clark's formula, there

is a resistance to train movements of eight pounds per ton, and the resistance increases with the speed at the rate of the square of the velocity in miles per hour divided by 171. American engineers had modified this to read six pounds per ton for the constant resistance, and accepted the remainder of the rule, so the common practice had become to calculate the resistance to trains on a straight level track to be

$$\frac{V^2}{171} + 6 = R$$

that is, V representing miles per hour and R resistance per ton. The rule stated in words is: Square the velocity in miles per hour, divide the results by 171, add 6 to the quotient, the result being the resistance at the rail in pounds per ton. This is the rule found in nearly all engineering text books, and they are all wrong when applied to American trains.

In the early eighties Angus Sinclair was requested by the Baldwin Locomotive Company to make tests of a group of locomotives purchased by the Burlington Cedar Rapids and Northern Railway which were reported to come short of their guarantee of power. He made a series of very carefully conducted tests, with indicator diagrams and records of water and coal consumption, finding that their power exceeded in every instance the rule given by the Clark formula, which was then the only rule in use. This led to further investigation concerning train resistance, and discussions of the subject have been going on ever since.

By the courtesy of the New York Central management Mr. Sinclair was permitted in 1892 to make a series of tests of the locomotive pulling the Empire State Express. In one of the runs made, a speed of seventy miles an hour was maintained for several miles and indicator diagrams were taken when the engine was doing the work of maintaining the speed without loss or gain. The power developed showed that the entire resistance of the train and the locomotive at that speed was 17.6 pounds per ton.

In the discussions that arise periodically about what the ultimate speed of trains will be, arguments are advanced to the effect that after a speed of sixty miles an hour is passed a point is soon reached where the locomotive will absorb the whole power developed in moving itself. Figures are always given to sustain this view based on the text book rules of train resistances. According to the Clark formula, so frequently used, the resistance per ton at 70 miles an hour is over 34 pounds. If this were true, there is not a locomotive in the country that could keep

a train of 300 tons moving at speed of 70 miles an hour.

The fact is that the square of the velocity does not in any manner represent the increase in train resistance due to acceleration of speed. This rule is utterly worthless and has no right to be used to deceive people who are striving to find accurate basis to calculate from. Its existence was evidently due to the desire of mathematicians to establish formulae for everything. In this case the formula was established without the necessary data upon which to build correctly.

A number of American railroad companies have used dynamometer cars for years in which excellent provision is made for keeping an accurate record of train resistance. Those go to prove not only that the resistance does not increase in proportion to the square of the speed, but that the resistance varies greatly according to the load per axle. On the Chicago, Burlington & Quincy Railroad a great many records were made, years ago, to find out the resistance of different kinds of freight trains, with a view to finding out how many cars certain locomotives ought to haul. A train of loaded freight cars weighing 940 tons gave an average resistance of 5½ pounds per ton when running 20 miles an hour on the level. A train of empty freight cars weighing 340 tons showed a resistance of 12 pounds per ton while running 20 miles an hour on level track. A passenger train weighing 363 tons gave 7½ pounds per ton resistance at a speed of 30 miles an hour. The records respecting train resistances of the roads operating dynamometer cars agree substantially with the recorded resistance of the Empire State Express.

When the record of the tests on the Empire State Express were published. Arthur M. Wellington, a well-known civil engineer, who had devoted much attention to the investigation of train resistance, wrote in his paper:

"The observations are among the most important evidences on record of the actual resistance of trains at high speeds. Perhaps we might even go farther and say that they are the most important, especially as they are reasonably consistent with the mean of the few other records which have been obtained for speeds of 50 to 75 miles per hour, while presumably far more trustworthy and decisive than any of the prior records. As such they are a real contribution to technical knowledge. We trust that they will attract the at-

ention they so very fully deserve.

Mr. Wellington then made comparisons of the data with those of a famous run made by Mr. Wm. Stroudley on the London, Brighton and South Coast Railway, and with figures of train resistance found by Mr. P. H. Dudley in his tests with dynamometer car; with the discoveries made on air resistance alone by Mr. O. T. Crosby in experiments with a high speed electrically-driven car. He remarked: "It is demonstrated by figures that Mr. Sinclair's record agrees substantially with the most reliable data relating to train resistances.

The element of axle friction only in train resistance is fairly determined at about 4 pounds per ton for passenger and loaded freight cars and 6 pounds per ton for empty freight cars at a speed of 10 to 30 miles an hour. The general law of friction is also well determined at very high journal speeds, the lubricants are so well carried around between the metallic surfaces that friction is generally reduced. It is now an admitted fact that the axle friction at the instant of starting is many times greater than after the vehicle is once under way, and that the drop from this high resistance, while very rapid, is by no means instantaneous, but requires a speed of from 5 to 10 miles an hour before the nominal rate is attained. The starting resistance at times rises considerably above 20 pounds per ton, i. e., a car on a one per cent. grade, which gives an accelerating force of 20 pounds per ton, will not always start of itself without aid. A force of 16 pounds per ton will very rarely start a car in motion. A fair average is 20 pounds.

While investigating the power of locomotives required to pull certain heavy fast express trains, Mr. S. A. Vauclain, of the Baldwin Locomotive Works, carried on a series of independent experiments, and he found the train resistance a little less than those formulated by Wellington from Sinclair's diagrams; but remarked that the figures were near enough for practical purposes.

From all the facts which we have obtained, added to Sinclair's and Vauclain's figures, we consider the subjoined table fairly represents train resistance per ton of 2,000 pounds:

Experiments on the largest types of locomotives have demonstrated the reliability of the data obtained, and the subject may now be said to have passed the experimental stage, as verifications have been established by dynamometers.

Miles per hour	10	20	30	40	50	60	70
Heavy passenger trains, Sinclair	4.5	6	9.5	12	14	17	19
Heavy passenger trains, Vauclain	..	..	..	..	11	13	15
Loaded freight cars	4	5.8	9.2	11.3	12.5	..	..
Empty freight cars	6	7.5	11	14	17	..	..

# Air Brake Department

## Operation of the New York P. S. Pneumatic Brake Equipment Special Fifty-Four "Air Compressor Strainer"—Care of Air Pump

### Operation of the New York Type P. S. Pneumatic Brake Equipment.

Last month's issue contained a brief reference to the New York Air Brake Company's type P. S. brake equipment for passenger car service with views of the general arrangement of the apparatus, and at the present time we have cuts of the triple valve in several different positions from which the operation of the brake will be explained.

There is but one size of operating valve for all sizes of brake cylinders and reser-

voirs, the triple valve being so constructed that it may be used for any size of brake cylinder by merely changing the feed port plug. The triple valve bracket is the same for all sizes of equipments, and is furnished with a special choke fitting to control the flow of air from the auxiliary reservoir to the brake cylinder, the size of the choke varying with the size of the cylinder.

In this brake, service and emergency features are separated for the purpose of avoiding the trouble that sometimes results from undesired quick action of brakes and by separating the triple valve parts controlling the service and emergency functions, no trouble encountered

with the service parts of the triple valve can result in undesired quick action, and through this separation an emergency application of the brakes can be obtained at any time following a service application. The principal features of the brake in addition to that of previous types are, quick recharge of the auxiliary reservoir, quick service in pneumatic operation, emergency operation obtainable at any time, and a high emergency brake cylinder pressure. In electric operation there is a

valve is concerned it will only be necessary to point out that in release position the valve may be in a quick recharge or normal release position depending upon the difference in pressure between the brake pipe and auxiliary reservoir. If in quick recharge position, which will be assumed immediately after a movement of the brake valve of the locomotive to release position, the auxiliary reservoir is charged in two ways from the brake pipe, through the slide valve seat and the main slide valve and through ports in the pis-

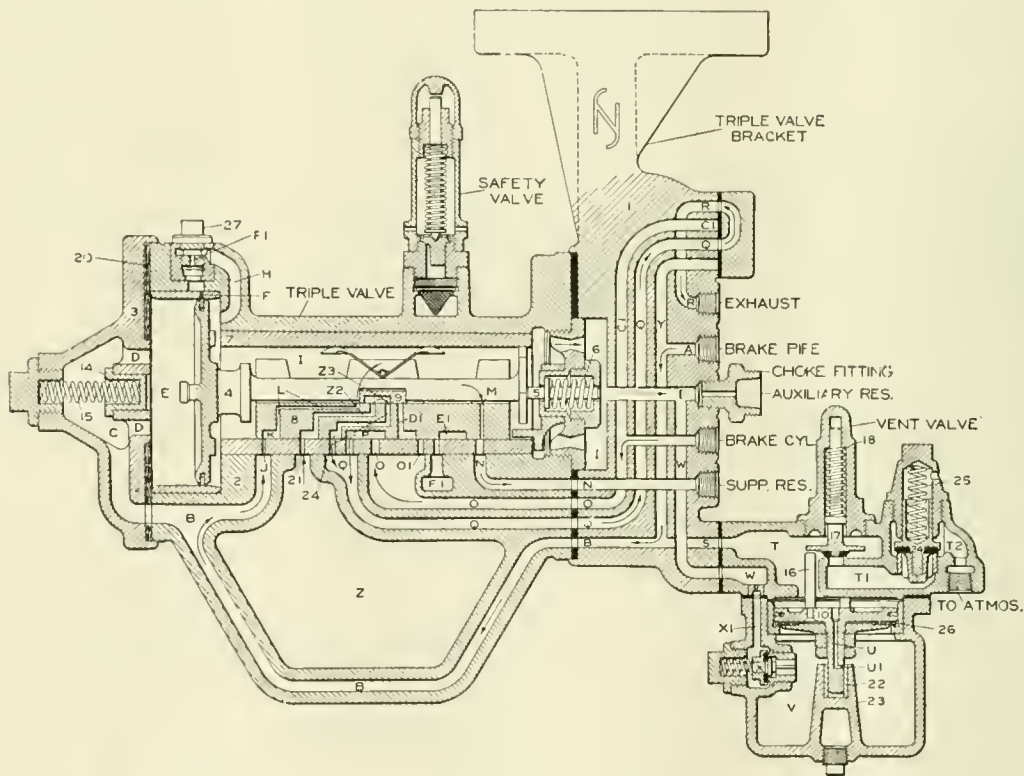

TYPE P. S. TRIPLE VALVE IN NORMAL RELEASE POSITION.

voirs, the triple valve being so constructed that it may be used for any size of brake cylinder by merely changing the feed port plug. The triple valve bracket is the same for all sizes of equipments, and is furnished with a special choke fitting to control the flow of air from the auxiliary reservoir to the brake cylinder, the size of the choke varying with the size of the cylinder.

In this brake, service and emergency features are separated for the purpose of avoiding the trouble that sometimes results from undesired quick action of brakes and by separating the triple valve parts controlling the service and emergency functions, no trouble encountered

simultaneous application of all of the brakes in the train and a graduated release.

In the four views of the triple valve and vent valve, which are diagrammatic, the action of the valves is shown in release, service, lap and emergency positions, and as the pneumatic portion is complete in itself and independent of the electric attachments, these four positions will be explained, after which the operation of the electric parts will be readily comprehended.

The operation of different types of triple valves is now so well understood that references to ports and passage are unnecessary, and so far as the triple

ton bushing and the choke plug shown at the top of the triple valve.

In normal release position the spring at the slide valve end of the main piston moves the piston and slide valve away from quick recharge position and closes the feed ports in the piston bushing so that the auxiliary reservoir is charged only through the ports in the slide valve.

A supplementary reservoir is charged at the same time as the auxiliary reservoir and after a brake application the quick recharge from the brake pipe is augmented from the supplementary reservoir and during application of the brake in service the supplementary reservoir is

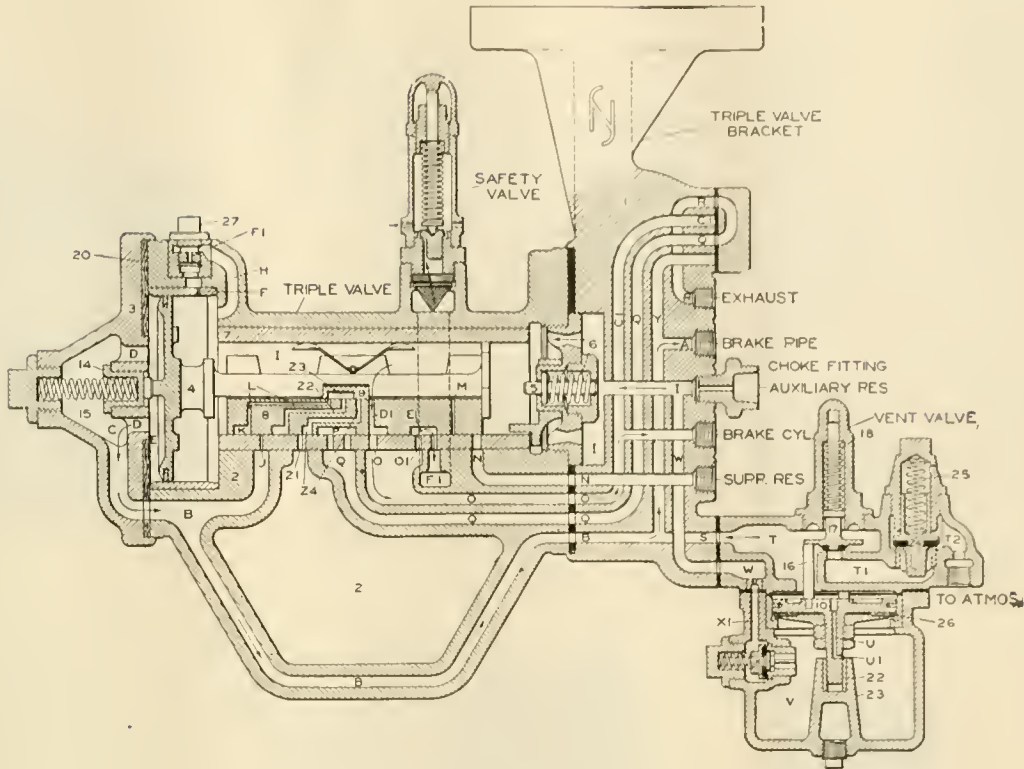

P. S. TRIPLE VALVE IN SERVICE POSITION.

separated from the auxiliary. During this charging the brake cylinder is open to the atmosphere through the slide valve in the usual manner and all movements are similar to those of the type L triple valve.

However, at the same time air from the brake pipe enters the bracket at A,

it also passes through passage S of the vent valve to chamber T and from there through passage U in the stem of the vent piston 10 and around the free fitting stem to chamber V and the under side of piston 10 until the pressure in chambers V and T is equal to that in the brake pipe. If the pressure in chamber

T and the brake pipe is greatly in excess of that in the auxiliary reservoir and passage W, the pressure in chamber V will unseat check valve X and feed through passages Xi and W to the auxiliary reservoir, thus preventing an overcharge of chamber V, which would cause undesired emergency in case the brake

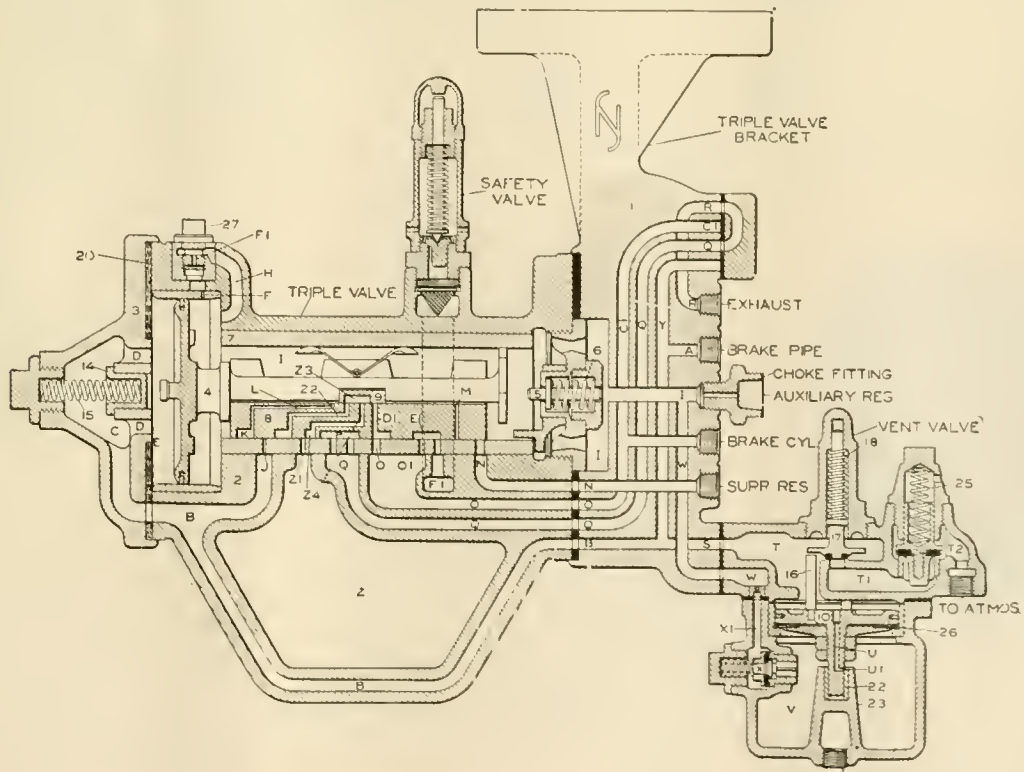

P. S. TRIPLE VALVE IN LAP POSITION.

pipe pressure would suddenly fall at the head end of the train, due to returning the brake valve handle from release to running position.

With the reservoirs charged to a pressure equal to that carried in the brake pipe, a brake pipe reduction causes a difference in pressure between the auxiliary reservoir and the brake pipe, consequently a higher auxiliary pressure creates a movement of the triple valve piston toward application position. As stated, in normal release position the feed ports in the main piston bushing are closed by the main piston and the only flow back that must be exceeded to produce movement is that through the restricted port J in the seat of the slide valve, and the first movement of the piston and graduat-

ion, and as the back flow from chamber V is limited to that which can flow around the free fitting stem, there will be created a differential of pressure on the vent piston 10 which will cause it to move forward, until the lifting pins 16 come in contact with vent valve 17 which is held to its seat by spring 18, aided by the brake pipe-pressure in chamber T.

A glance at the diagrammatic views will show that port U will then connect chambers V and T and no further action of the vent valve will occur provided that the service rate of brake pipe reduction is not exceeded.

The action of the triple valve with respect to movements from service to service lap position will require no explanation and the safety valve is connected

that the brake cylinder exhaust port is closed and the safety valve is cut off from communication with the brake cylinder and that both the auxiliary and supplementary reservoir pressures are free to expand into the brake cylinder producing the high emergency brake cylinder pressure which is held to the stop.

The release after emergency is accomplished by increasing the pressure in the brake pipe in the usual manner, and both the auxiliary and supplementary reservoirs are charged from the brake pipe, the unseated valves 17 and 24 of the vent valve having returned to their seats by the actions of the springs as the brake pipe pressure is reduced below their tension and may be confidently relied upon.

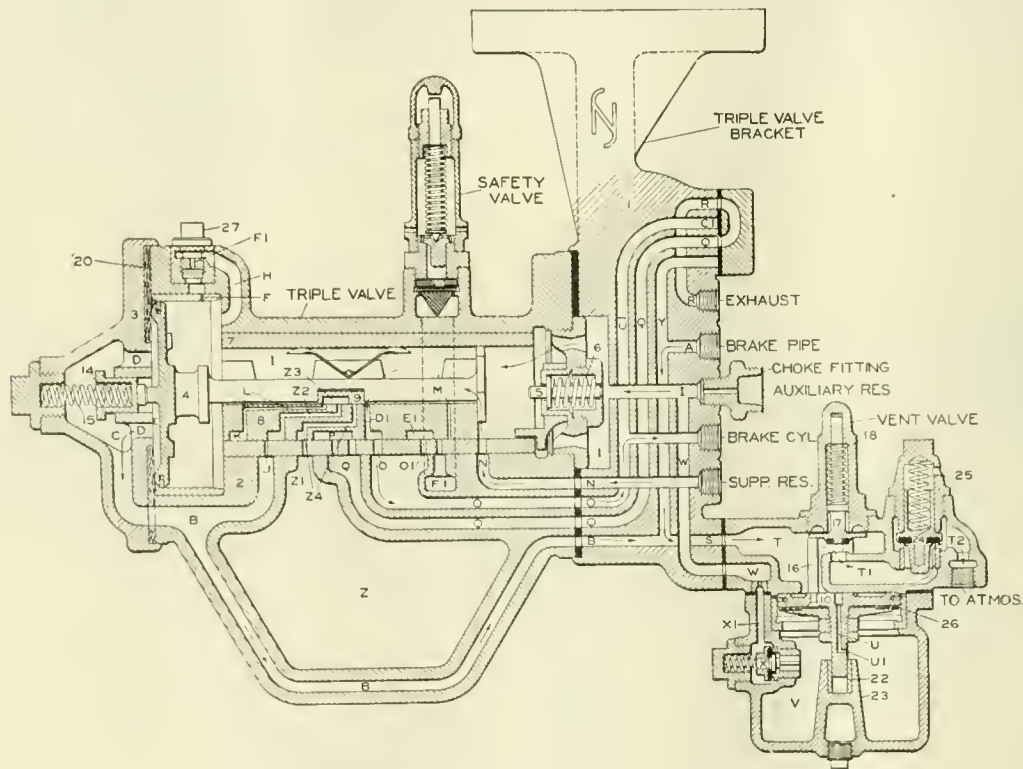

P. S. TRIPLE VALVE IN EMERGENCY POSITION.

ing valve entirely closes communication between the auxiliary reservoir and the brake pipe and opens the brake pipe to chamber Z for a venting of brake pipe pressure in addition to that of the locomotive brake valve and this venting occurs before the main slide valve moves. When the slide valve moves the graduating valve has uncovered the service port which connects with the port leading to the brake cylinder and the supplementary reservoir is cut off while the slide valve has also closed the brake cylinder exhaust port. From this it will be understood that the triple valve operation is identical with that of all previous types of triple valves. At the same time the brake pipe reduction is taking place in the brake pipe proper, it is also taking place in chamber T in the vent valve above piston

with the brake cylinder during service operations and is cut off from the cylinder during emergency applications.

When an emergency application is made, the rate of brake pipe reduction exceeds the capacity of the opening between chambers V and T in the vent valve, causing a higher pressure in chamber V, which moves the vent valve upward with sufficient force to unseat valve 17, and so exhaust brake pipe pressure through valve 24 to the atmosphere for the serial transmission of quick action.

This same rapid reduction of pressure in the brake pipe will permit the auxiliary reservoir pressure to move the triple valve piston to its full stroke, or to emergency position.

A glance at the diagrammatic view of the valve in emergency position will show

**Special "Fifty-Four" Air Compressor Strainer.**

The Westinghouse Air Brake Co. has developed a new type of air pump strainer known as the "Fifty-Four" derived from the fact that the "suction" area is approximately fifty-four inches.

A circular notice explains that with the large volume of air drawn into the compressors, especially the large capacity compressors commonly used, more or less foreign matter enters the air cylinders when engines are standing over ash pits or when operating through desert sections, and without an adequate strainer this dust and grit entering the cylinders not only necessitates more frequent renewals of packing rings and reboring of cylinders but will seriously interfere with the lubrication of the cylinder and thereby

shorten the life of the cylinder casting. A clogged strainer will cause the compressor to increase the power consumption

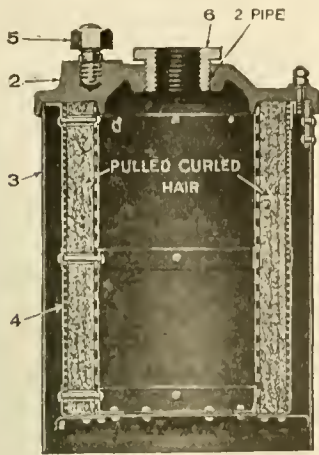

SECTION VIEW OF STRAINER.

per cubic foot of air compressed and may sometimes result in a failure to maintain the required pressure for the brake system. It is obvious that if a strainer is to be efficient in keeping dirt out of the air cylinders and is to be kept from clogging up, it must be cleaned with sufficient frequency, depending entirely upon the margin of capacity the strainer has.

The cuts used in this issue will give a fair idea of the construction of the strainer, it is made in one size but of ample capacity for the larger compressor. This strainer is not furnished with the standard compressors except when specified, and the cost of strainer and any information desired with reference to it will as usual be furnished by the company upon application.

**Care of the Air Pump.**

In air brake instruction a great deal of stress is placed upon the importance of knowing what to do in case of an air pump failure, that is, in case the pump becomes disabled or fails to maintain the air pressure required to operate the brakes while out on the road. Usually the instructor and the road foreman of engines insists that the fireman, who is up for promotion, shall know exactly what to do under all circumstances surrounding an air pump failure. The instructor goes into the matter in detail, and it is one of the most important parts of air brake instruction, as it comes under the heading of what to do in emergency cases when out on the road, and this should be given as much time and attention as possible. Every road man should know exactly what to do in any possible case of air brake failure before he is brought face to face with the actual proposition, as emergencies are always unexpected, but in air brake practice the care of the equipment must also be con-

sidered. If an ounce of prevention is ever worth a pound of cure, it is in the care of an air pump.

There is always a cause for an air pump failure, which arises from some defect or disorder which if discovered in time would prevent the failure. The most prolific cause, in fact, almost invariably the cause of the disorder or defect, is primarily due to the lack of care or attention, or due to what may be termed the abuse of the pump.

What to do to the pump under various circumstances is at all times a live subject, and what not to do at any time should be given much more attention than it usually is. We know positively that pumps can be repaired in a manner that will insure their life in service to depend upon the treatment they receive after being placed in service, in fact, the character of air pump repair work in the majority of railroad shops throughout the country is such that the life of the

merely lodged in the air strainer it could easily be removed again, but the ashes and cinders enter the cylinder and cut the walls and the packing rings. Another reason why the pump should not be used on the fire track is that authorities on the subject claim that the acids in the gases arising from the smoldering fires combine with other chemical effects in causing an oxidation, or in destroying the reservoir from the inside and under certain conditions these gases will ignite and result in the main reservoir explosion.

When the pump is started, the throttle should be opened but about one-fourth of a turn of the wheel and be allowed to remain that way until the steam cylinder becomes heated and until about 40 lbs. air pressure has accumulated in the main reservoir. It is a common practice for the fireman or a hostler to open the pump throttle wide while there is no air pressure in the main reservoir or while the steam cylinder is full of condensation,

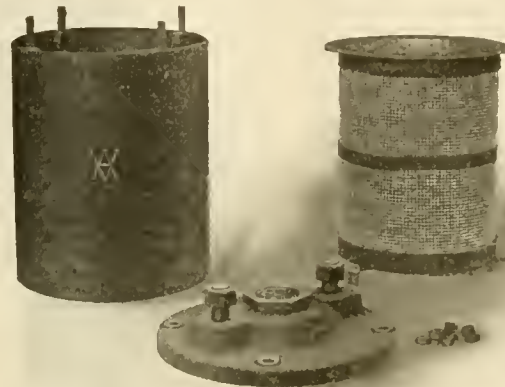

DISASSEMBLED VIEW OF STRAINER.

pump depends entirely upon the care it receives after it is placed upon the locomotive.

Taken from almost any point of view, the question as to what to do after an air pump has failed is of secondary importance to the question as to what should be observed and done before the failure occurs, after the failure, the damage is done and no amount of reflection upon what might have been done will alter the case.

In order that those who use the pump, whether engineers, firemen or hostlers, may be entirely free from sharing in the responsibility for an air pump failure, that that is not due to poor workmanship or defective material, there are some rules in reference to starting a pump that must be observed. In the first place the air pump should not be used on the fire track or ash pit; if it is, a considerable quantity of ashes and cinders will be drawn into the air cylinder that otherwise would be avoided. If the dirt drawn toward the pump in this manner,

which is certainly the outcome of ignorance or of careless habits. This should not be tolerated, even if the location of the steam valve is at an inconvenient



EXTERIOR VIEW OF STRAINER.

point, because it is safe to say that about one-half of the unfair usage of pumps occurs when they are first started.

## Davis Type of Close Coupled Lathe

If the pump is started with a wide open throttle, the steam piston striking the condensation, throws an unnecessary strain on the cap screws with which the top head is fastened, thereby causing the gaskets to leak and waste oil that should reach the pump, but the most destructive feature is that when the pump is started in this manner the pistons are often thrown against the center piece with sufficient force to fracture or break pieces out of the lower side of the steam piston or the upper side of the air piston, this being due to insufficient air pressure to cushion the pistons. This striking or banging of the pistons often results in loose reversing plate bolts, or in the air piston working loose on the rod, and anyone who is called upon to loosen the nuts on a bolt knows that if a nut is drawn so tight or corroded that it cannot be loosened with a wrench, the first move is to beat it with a hammer, and this is usually an effective way to loosen the nut, and the blow the air piston receives as a result of the practices mentioned will eventually result in some unnecessary damage such as loose nuts or broken piston rods and while it may not occur the first time the pump is abused in this manner, the treatment is slowly but surely paving the way for a pump failure.

There are, of course, drain cocks in the steam cylinder placed there for the purpose of relieving the cylinder of the condensation when the pump is first started, but they are seldom if ever used.

We have frequently referred to the effect of an overheated pump, and the only temporary remedy is to reduce the piston speed and keep the air cylinder oiled, and at the end of the trip, determine the cause of the heating. Oiling a pump does not necessarily mean pouring a quantity of engine oil into the air strainer, but the temptation is sometimes very great, especially when some of the patent oil cups are in use, and if it ever becomes necessary to oil a pump through the strainer, it is a very poor policy to use engine oil, and while we seldom hear of an air pump exploding, some engine crews can testify that engine oil will flash under a high temperature and explode the pump or throw it off the engine.

The above refers chiefly to the single acting pump, as it is an exceedingly difficult matter to break down the cross compound type of compressor, the pistons are cushioned before pressure is accumulated in the main reservoir and the compressor will not pound even if the throttle is opened wide instantly and it is impossible to run it at a prohibitive rate of speed, in fact there is but about one way in which the pump can be disabled and that is by the use of an excessive quantity of oil in the air cylinders or an excessive quantity of superheater oil in the steam cylinder, and these troubles should be at all times carefully guarded against.

Among the more recent important additions to what are known as close coupled lathes adapted to meet modern requirements for high speed, heavy duty and accurate tool room service the Davis Machine Tool Company, Rochester, N. Y., have introduced many radical improvements that are already meeting with much favor especially for that growing class of work where exact standardization is an absolute necessity, combined with the highest measure of output of which the best tool steel is possible of producing.

The accompanying illustration shows a 12-inch close coupled lathe which embodies a number of excellent new features among which it will be noted that the head stock is a heavy casting with the front and rear bearings securely bound

A motor drive can be fitted to head with direct current variable speed motor,  $1\frac{1}{4}$  horsepower having speeds from 500 to 1,500 revolutions per minute, with perfect controlling apparatus. An automatic stop and reverse rod is provided which controls the travel of the carriage in either direction for feeding or screw cutting. The apron is of the double plate type with two bearing supports for all shafts. A new interlocking arrangement is provided so that both feed and half nut cannot be thrown in at the same time. The quick change gear box is also a new and valuable feature, and provides for cutting threads from  $1\frac{1}{2}$  to 80 per inch, including  $11\frac{1}{2}$  pipe thread. There are 36 changes possible which can be instantly obtained from the gear box and sliding gears at the

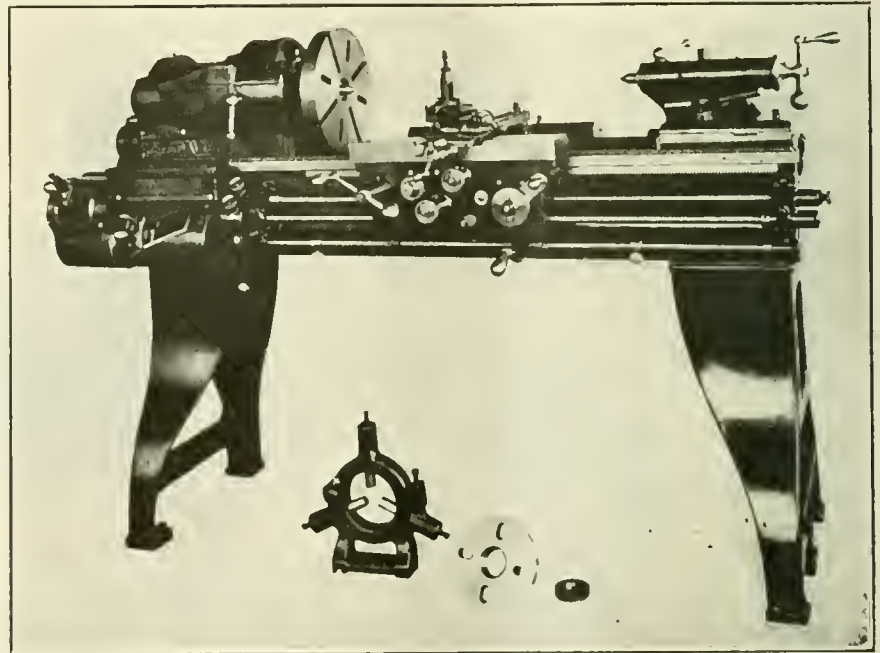

DAVIS TYPE OF 12 IN. CLOSE COUPLED LATHE.

together by straight walls which are brought up to the spindle center, thus providing a substantial guard for the lower half of the cone pulley, the gears being covered by guards which are made integral with the head. The casings are bolted by flush head screws, thus giving a degree of rigidity and freedom from vibration hitherto unattained. The gears are underneath the front bearing and the cone, supported by legs cast on the front and rear of the head, avoiding a long eccentric shaft and quill, avoiding all torsional strains. The gears are brought into mesh by a handle just below the feed rod at the head and within easy reach of the operator's left hand. The carriage has long bearings on ways with deep bridge, and both cross feed and compound rest screws are fitted with micrometer collars graduated to 1,000th of an inch.

end of the lathe. Special leads can also be cut by changing gears on an auxiliary quadrant, which is furnished with each lathe.

In the important matter of alignment there is also something new. As is well known an uneven floor not infrequently destroys the perfectly straight alignment. To insure a perfectly level bed an extra foot is placed on the right leg of the lathe which will carry weight and provide a three-point support. This may seem simple but it is a perfect assurance of a freedom from strains, and completely overcomes any tendency of rocking by bolts being placed in the ends of the leg which on a perfectly level floor can be set down to just touch the floor, but not to carry any weight. The floor space for this fine type of lathe is about  $28\frac{1}{2}$  square feet, weight 1,350 pounds.



# Improved Pop Valve for Locomotives

Much has been attempted in regard to high and low lift safety valves, and the problem of constructing a safety valve that will insure a high discharge has engaged the attention of many engineers, and clever devices in the way of auxiliary pistons and other contrivances have been experimented with but little real progress was made until recently. High lift valves, so called, produce more or less shock at closure which may injure the boiler, and the need was for a safety valve where there was a substantial increase in discharge capacity, with lower closing lifts than those now in use.

It has now been demonstrated that it is possible to produce a valve of high lift as regards discharge capacity and low lift as regards the shock at closure. This latter feature removes the most serious objection to high lift, as high lift valves must come into general use as the safety requirements in boiler practice must be more economically met than is the case at present.

The Crosby Steam Gauge and Valve Company, Boston, Mass., have recently placed on the market a high-efficiency pop valve for locomotives. It has been developed under the recent invention of Mr. G. H. Clark for the company, and incorporates an important improvement proposed by Prof. Miller, of the Massachusetts Institute of Technology, who was the first to round the edges of a safety valve in order to increase the efficiency of discharge per unit of lift, and in so doing took a long step in the direction of high safety valve efficiency.

The new valve as perfected by Mr. Clark may be readily understood by referring to Fig. 1, which shows a valve which has means for adjustment which are based on the production of variable lifting force. The two annular rings shown at A and B carry on their upper surfaces curves which approximate in shape the curve of the disc. The inner ring A, which may be called the warning ring, is threaded upon the base of the valve just outside the flat seat and carries, threaded upon it, the ring B, which is adapted to control the blow-down. These rings may be lowered away from the disc, or given what may be termed initial clearance. It will be readily understood that if both of these rings are lowered an extreme distance, when the valve tends to open no lifting force will be available. If the ring A is raised to a position near the valve disc, a lifting force will be provided which will depend on the pressure produced between it and the disc, and on the extent of the disc area on which this pressure acts. The pressure depends on the area of the passage and the area on the valve is a function of the initial clearance and the shape of the

curve. These factors are built into the valve to produce the desired result, which is to provide lifting force at small lifts to overcome excessive warning, and it has been found that with the proper shape of ring, on its initial clearance, depends the warning of the valve. Since this warning

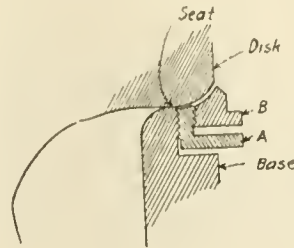

FIG. 1. SECTION VIEW OF VALVE SEAT.

ring alone produces only small lifts, it has no appreciable effect on the blow-down.

Now as the blow-down ring B is raised from its lowest position, there is a tendency to build up pressure between it and the disc when the valve is open, which tendency increases as the disc is approached. If a reasonably large clearance is left, it is clear that this ring produces almost no lifting force at low lift, since the area of the passage along this ring is large in comparison to that over the seat,

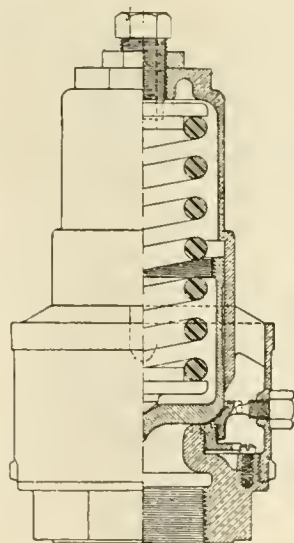

FIG. 2. SECTION VIEW OF IMPROVED SAFETY VALVE FOR LOCOMOTIVES.

and it follows, also, that as the disc lifts the effect of this initial clearance on the area of the passage becomes less and less as lifting continues.

Repeated tests of this valve have proved the value of this method of regulation in that all the requirements of practice are afforded by it for all of the high lifts. In ordinary practice the valve is adjusted to give no warning, avoiding preliminary simmering, but can be set at two pounds

warning if desired, this being independent of the blow-down regulation.

The valve is easy of adjustment. To increase the blow-down the large ring may be turned to the right,—to left to decrease blow-down. A screw plug holds the lock ring in position.

Fig. 2 shows detail view of locomotive valve of approved design. When the rings are adjusted to the desired points, it should not need changing, and in regard to amount of discharge for pipe connections of either 3-inch or 3½-inch the conservative estimate is from 13,000 to 16,000 pounds per hour, the advantages being that there is a maximum steam discharge through a much larger opening than any other safety valve, and a complete absence of hammering or chattering, and consequently longer wear without leaking or re-seating.

## President Bids Good-Bye to Locomotive Engineer.

In the course of his speech at the Press Club of New York on June 30, President Wilson said: "I got off a train yesterday and as I was bidding goodby to the engineer, he said: 'Mr. President, keep us out of Mexico.'" That was a small incident, but it displays a laudable American spirit—the wish to speak a kind word to the engineer who has brought passengers safely to the end of a journey.

That was one of the good habits of Colonel Roosevelt when he was president. We do not know if he still keeps up the practice, but when he was president he never failed to say a kind word to the locomotive engineer at the end of a journey. When the writer was first introduced to President Roosevelt he asked some particulars of the writer's experience. The president exclaimed: "You have been a locomotive engineer and now you are editor of a prosperous journal. I think you have reason to be a proud man."

## Insulating Apprentices.

In some British railway repair shops, small tools, such as lathe planers, shapers and similar appliances, are kept in a room partitioned off from the rest of the shop, and here all the young apprentices are kept at work away from the other mechanics. This arrangement is carried out on moral grounds. The belief is that the ordinary workman exercises an evil influence on the young apprentice. The belief prevails that when the apprentice has acquired some skill in the trade, he is not so susceptible to the evil influences of the older men, and can therefore be admitted among them with impunity. The spirit of moral reform touches the British workman very highly.

# Electrical Department

## Catechism of the Electric Locomotive Continued

Q. To what piece of apparatus does the lead Fig. 4 connect?

A. To the main switch.

Q. Of what does the main switch consist?

A. The main switch usually consists of a heavy, single pole knife switch mounted on a marble or slate base. The motor current passes first through this switch.

Q. What is the purpose of this main switch?

A. To provide a means of cutting off the power from the electrical apparatus in the cab of the locomotive, thus making it possible to inspect the control apparatus, motors, etc., without danger.

Q. What is the main circuit breaker?

A. It is an automatic switch, of high capacity which can be closed and opened by the engineer from his operating position.

Q. What is the automatic feature of the circuit breaker?

A. The circuit breaker is automatic in that it will open when the current exceeds a definite value. The excess current may be caused by the engineer notching up the controller too rapidly, thereby allowing more current to pass through the motors unless interrupted by the circuit breaker, or by a failure of the electrical apparatus causing a ground and resulting in a high rush of current which must be cut off, otherwise serious damage to the locomotive would result.

Q. In what part of the circuit is the circuit breaker located?

A. Directly after the main switch and ahead of the other electrical apparatus.

Q. What procedure should be followed if the main fuses should blow?

A. First paddle the shoes—this consists in inserting a flat board, which has been specially shaped for convenience and called a third rail shoe paddle, between all of the shoes which are in contact with the rail, and the rail; then loosen up the thumb screws remove the burned pieces of fuse, insert a new fuse and tighten the knobs.

Q. Why are the paddles put between the shoes and the rail?

A. To disconnect the shoe rigging from the third rail so as to protect the man working on the fuse boxes.

Q. Do all circuits pass through the main switch?

A. Usually not.

Q. What apparatus is available for service, when the main knife switch is open?

A. The auxiliary apparatus consisting of lighting circuits, compressor, blower

(when used), control circuits, when a battery is not used.

Q. How is this possible and what is the advantage gained?

A. The wires to the auxiliary apparatus are connected to the power supply on the third rail shoe side of the main switch. With this arrangement the lights, compressor, etc., are available for use without any power being connected to the electrical switches and motors. This makes it possible to work around the locomotive and test out the operation of the control apparatus without any current passing to the motors and at night lights are available for inspection.

Q. Are these auxiliary circuits protected in any way?

A. Yes, by enclosed fuses usually mounted in boxes. It is possible to use enclosed fuses to protect the auxiliary circuits as the current taken by each piece of auxiliary apparatus is only a few amperes.

Q. On D.C. locomotives what other

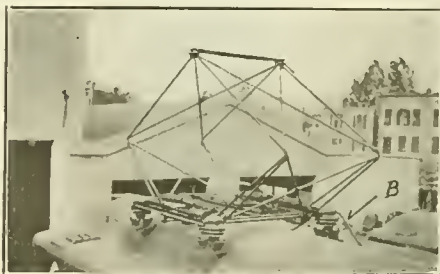

FIG. 6. PANTOGRAPH RAISED.

piece of apparatus is used besides the third rail shoes for collection of the current?

A. An overhead trolley.

Q. How is this connected and how does it operate?

A. The overhead trolley is connected to the leads connecting the third rail shoes together and therefore is alive whenever the third rail shoes are in contact with the third rail. The purpose of the overhead trolley is to provide a means of keeping the current continuously on the locomotive when operating in yards where the third rails are broken (gaps) on account of the tracks crossing each other it being impossible to have a continuous third rail. Keeping current on the locomotive continuously is very important when the locomotive is starting up a heavy train out of the terminal as interruption of the current would not only interfere with the getting of the train out of the station at proper speed, but would cause serious surges to

the train and to the electrical apparatus unless the engineer should shut off at each gap. It may not be necessary at all times to use the overhead trolley, as there will be sufficient momentum to carry the locomotive over the gap. The overhead trolley is normally in its lowest position and is only raised to make contact with the overhead third rail when necessary. The operation of the trolley is under the control of the engineer and is raised by air pressure, the weight being sufficient to bring it down when air is released from the piston.

We have traced the circuits in the case of direct current locomotives from the third rail through the shoes and the main switch to the unit switches where the current is controlled and the motors are connected in the various combinations. Before taking up the construction of the unit switches or control apparatus, as it is called, we will refer to the apparatus used for collection of current in the case of alternating current and high voltage direct current locomotives where the current is taken from an overhead wire instead of a third rail conductor located alongside of the track.

Q.—What is a pantograph trolley?

A.—It is the device which is carried on the top of the A.C. or high voltage D.C. locomotives for collection of the high voltage current.

Q.—How is the pantograph constructed?

A.—It is constructed of light steel drawn tubing, the general arrangement shown by Fig. 6. This framework is carried on a base, same being insulated from the roof of the locomotive by four large petticoat insulators shown by "P" Fig. 7. On top of the tubing is carried the shoe shown by "S" Fig. 2 to which is fastened on either end, a horn "H" Fig. 2 to prevent the pantograph from catching in the wire when passing through cross-overs. The shoe is usually 4 to 6 inches wide and is made of pressed steel.

Q.—What keeps the shoe in contact with the wire?

A.—Spring shown by "C" Fig. 7. These springs can be adjusted to give a variation in pressure of the shoe against the wire.

Q.—How is the pantograph lowered to the down position, as shown in No. 7 and how is it held in this position?

A.—The pantograph is lowered by air pressure being admitted to the air cylinder "A" Fig. 7; when the pantograph reaches the down position it is held down

by a latch or hook engaging with the framework.

Q.—When in the down position, how is the pantograph raised?

A.—Air is admitted to a small cylinder which disengages the latch and the pantograph is carried up due to the action of the springs "C." The air to both the unlock and trolley down cylinders is under the control of the engineman and the trolley is usually raised and lowered by simply pressing a button located on or adjacent to the controller.

Q.—How is the current taken from the pantograph to the locomotive?

A.—Through a cable, "B" Fig. 6. This cable passes through a pipe into the locomotive.

Q.—Into what piece of apparatus does the cable from the pantograph trolley terminate?

A.—Into an oil circuit breaker.

Q.—What is the purpose of the oil circuit breaker?

A.—The oil circuit breaker is used to close the high voltage current in the case of the A.C. system to the transformer. It corresponds to the main switch of the low voltage direct current locomotives but in addition it is automatic, opening on overloads or short circuits in the locomotive.

Q.—What is the construction of the circuit breaker?

A.—The circuit breaker consists of an operating handle, fitted with a releasing trigger, which is connected to a wooden rod carrying contacts. When the handle is pushed down the movable contacts are raised and make contact with stationary contacts, thereby connecting the 11,000 volts high tension current to the transformer. The contacts are surrounded by oil carried in a tank.

Q.—What is the object of the oil carried in the tank and is same special?

A.—The oil is necessary to extinguish the electric arc. The high voltage arc which occurs when breaking circuits is very severe if the circuit is broken in the air but is nearly negligible when broken in oil. The oil must be of a special kind usually known as transformer oil.

Q.—How is the oil circuit breaker operated?

A.—When power is desired for operation of the locomotive and the pantograph has been raised, power is connected to the transformer by pushing down on the circuit breaker handle until same latches. Power can be disconnected from the transformer by pressing in on the button located in the end of the handle unlocking the catch, allowing the circuit breaker to open.

Q.—What is the object of the transformer?

A.—To step down to high voltage alternating current, which is usually 11,000 volts, to a voltage suitable for the motors and auxiliary apparatus, the auxiliary

apparatus consisting of the compressor, blower and lights.

Q.—What is the construction of the transformer?

A.—The transformer consists of many turns of electrically insulated wire wound in the form of flat coils, C Fig. 8, the separate coils connected together and the whole surrounded by iron I. Between groups of coils are inserted layers

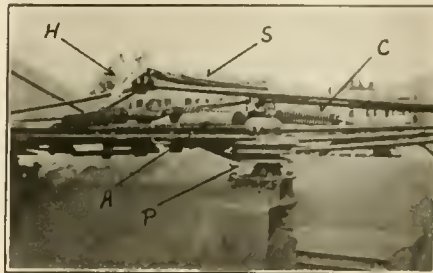
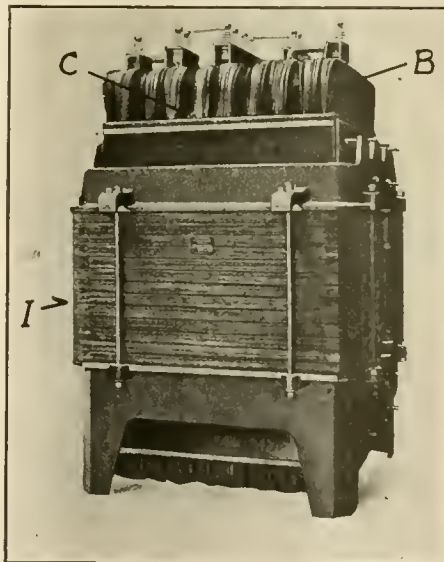

FIG. 7. PANTOGRAPH LOWERED.

of insulated located boards (B) to prevent electrical breakdown between the groups of coils. The iron is held in position by the bolts which clamp the castings firmly to the iron.

Q.—Is the transformer cooled and how?

A.—Yes; it is necessary to cool the transformer so as to get the maximum amount of power from same. On locomotives it is cooled by air passing



INSIDE CONSTRUCTION OF TRANSFORMER.

through same, the air being taken from the duct to which the blower is blowing air.

Q.—What means is provided so that transformer will be uniformly cooled?

A.—The transformer is enclosed in a sheet iron case and the air enters at one end and passes out at the other. In order to prevent the transformer from overheating at the coils inside of the iron, ducts are provided between the coils so that the air can pass up through these

ducts and carry away the heat. The ducts are formed by placing strips of wood between the coils before they are assembled in groups, and thus many passages are provided for the air and the whole mass is kept cool.

Q.—What two types of transformers are used in connection with locomotives and car equipments?

A.—The auto and the double coil transformer.

Q.—What difference between the two types.

A.—The auto transformer has all of the coils connected together. The 11,000 volts is connected to the high tension end and the other end of the transformer is connected to the ground. Starting in at the trolley end we have 11,000 volts. If it was possible to follow down along the coils and measure the voltage we would get a lower and lower voltage, according to the distance from the high tension end until we reached the ground connection when the voltage is zero. It is, therefore, possible to get any voltage desired from 11,000 to 0 volts by bringing out a lead known as a tap. The double coil transformer, as the name suggests, has two coils, a high tension coil and a low tension coil which do not connect. The high voltage coils are connected between 11,000 volts and ground, while the low voltage windings are entirely separate and the current is formed in the winding by induction.

Q.—What do you understand by induction?

A.—When the high voltage alternating current is connected to the high tension winding the alternating current sets up lines of force in the iron which vary in strength according to the frequency. These lines of force surround and "cut" the low tension coils and induce the voltage and current in them.

Q.—What is the compressor?

A.—The compressor is the air pump of the electric locomotive.

Q.—How is this air compressor or air pump controlled?

A.—It is controlled by means of the governor which cuts in and out according to the air pressure in the reservoir. The cutting in and out of the governor connects and disconnects the electric power to the electric motor which drives the air compressor through gearing.

Q.—Wherein does this compressor differ from the steam air pump?

A.—The steam air pump maintains practically a constant pressure in the main reservoir and operates pumping air to maintain this pressure with the slightest reduction. In the case of the electric driven pump or compressor, as it is called, pressure is not maintained at a constant value, but there is usually a variation of 10 lbs. between the maximum and minimum. For instance, the governor is set at a 10 lb. range and on locomotives with

feed valve set for 110 lbs. train line pressure, the governor would cut in at 120 lbs. (minimum reservoir pressure) and cut out at 130 lbs. (maximum reservoir pressure). With this arrangement, the compressor is not pumping continuously and in the design of the locomotive sufficient compressor capacity is usually specified so that the compressor will only operate about 50 per cent. of the time.

Q. Most electric locomotives are equipped with motor driven blowers. What is the purpose of the blowers?

A. These blowers are used for furnishing air to the main motors, transformers and any other apparatus which it is desired to cool. The capacity of the electric motors and other electrical apparatus is determined by the temperature of the apparatus when operating under load. The passing of air through the electrical apparatus carries away the heat and allows greater work to be done. This means that the capacity of the electric locomotive for the same weight and cost can be increased and by an amount within certain limits depending upon the amount of air blown through the apparatus. It is easily possible to increase the capacity by ventilation over 50 per cent. The air is conducted to the various pieces of apparatus from the blower through ducts usually built into the flooring and framework of the locomotive.

Q. Through what pieces of apparatus are the compressors and blowers connected to the power supply?

A. The electric motors operating the air compressors and the blowers are connected to and cut off from the power supply usually by means of small hand-operated enclosed switches known as canopy switches, and it is necessary to have these switches closed for operation of the apparatus even though the D. C. power or alternating current is on the locomotive. In addition to the canopy switches an enclosed fuse is inserted in the circuit so that power will be cut off from these auxiliary motors in case of trouble, the canopy switches usually not being automatic and opening on overloads.

#### Union Traction Co. of Indiana Purchase Twenty Equipments.

An evidence of the better financial conditions throughout the railway field is shown by the recent order placed by the Union Traction Company of Indiana with the Westinghouse Electric & Manufacturing Company for twenty complete quadruple equipments of the latter's No. 333-V motors and HL control. These new equipments will replace some of their high speed passenger equipments consisting of 50-C motors and type L hand control. Aside from the reduced maintenance, resulting from the more efficient types of motors and control, the desirability of train operation was one of the

factors in making this change, and the new cars will not run in train with each other, but also with the present equipments of Westinghouse No. 303 motors and HL control, of which the Union Traction Company of Indiana have seventeen equipments now in operation.

#### Statistics of Steam Railways in the United States.

The Government printing office has just issued an abstract of statistics of steam railways in the United States for the year ending June 30, 1915, from which it appears that the aggregate mileage of railway tracks of all kinds covered by operating returns was 391,141.51 miles, classified as follows: Miles of road, 257,569.32; miles of second main track, 28,644.67; miles of third main track, 2,714.30; miles of fourth main track, 1,925.35; miles of all other main tracks, 377.71; miles of yard tracks and sidings, 99,910.16. The figures for total mileage, all tracks, as compared with the corresponding statement for the preceding year, show an increase of 3,933.30 miles. The report also shows that there were 65,099 locomotives in service, of which 64,835 were steam locomotives, and of others 264. The total number of cars of all classes in service was 2,507,977, assigned as follows: Passenger service, 55,705 cars; freight service, 2,356,338; company service, 95,934. Private cars of commercial firms or corporations are not recorded. The average number of employees reported in service during the period referred to was 1,409,342.

#### Superstitions of Trainmen.

On nearly all railroads there are passenger train cars and certain locomotives that are reported by trainmen to be unlucky. Trainmen as a class are superstitious, and in this they resemble sailors.

Men engaged in a hazardous occupation are nearly always superstitious. The cause for this is not hard to find. When they meet with so-called bad luck, any preceding incident is apt to be regarded as an omen, and men who work with their lives in their hands have their perceptions quickened for such omens.

We were once very forcibly struck with the strong belief some men entertain as to the efficiency of an old horseshoe in preventing accidents to locomotives. We had a fireman who kept an old horseshoe fastened to the inside of the cab. It was a rough article that was far from being ornamental in appearance, and it struck that fireman one day, that a little grinding and polishing would improve its looks. So he took it to a grindstone and proceeded to polish the article with emery and sand paper. The call to go out with a train came before he finished the work of polishing, so he left the

horseshoe in the roundhouse. The train had only got five miles out, when through a mistake in orders we met another train on the same track. We met on a curve and there was some lively scrambling among the trainmen to get as far as possible into the country before the crash came. The fireman displayed extraordinary agility, but his flight was arrested by the clutch of a barbed wire fence. As he vainly struggled to free his unmentionables from the entanglement he exclaimed, "If I had left that blamed horseshoe on the engine this would not have happened."

#### Ventilating Tunnels on the Baltimore & Ohio.

Comforts of travel on the St. Louis line of the Baltimore & Ohio Railroad have been increased by an improved system for ventilating tunnels which has been installed in the mountainous district traversed in West Virginia between Clarksburg and Parkersburg. A ventilating plant has been completed at Eaton and work of similar character is being rushed as rapidly as possible at West Union. Two others at Silver Run and Ocean will be ventilated during the present season. The ventilating system, involving an expenditure of \$70,000 each, draws fresh air ahead of trains and insures comfortable temperature. This is accomplished by means of large revolving fans, propelled by steam power plants located at the portals. The water supply necessary for the operation of the plants was secured by digging wells to a depth below the point of pollution. Some time ago the Baltimore & Ohio installed a ventilating system in the westbound bore of Wingard tunnel. This experiment has been satisfactory.

#### Better Times Coming.

In spite of senseless restrictions that are calculated to reduce the earnings of our railroads most of the transportation companies are doing an unusually remunerative business. When individuals are unusually prosperous it is nearly always manifested in their liberality in the purchase of household conveniences and luxuries, and railway companies have generally denoted enlarged incomes to the purchase of new equipment and new tools, but we find that prosperity has done little so far to induce railroad companies to become purchasers on a large scale. The necessity for rigid economy that has prevailed for years, is not yet forgotten, and much labor continues to be expended upon ancient rolling by antiquated tools that ought to be changed. We trust that railroad companies will not repeat past mistakes in refusing to make renewals when they have the money to make purchases.

Unless the seed is placed in the ground the crop will not grow.

**Angus Sinclair as Doctor of Engineering.**

An esteemed friend in Montrose, Scotland, writes: In various engineering papers that reach me occasionally, I find my old friend Angus mentioned as Dr. Sinclair. As I know that you are no minister of the gospel or medical man, I would like to know from whence you derive the honorary title of doctor? Replying to the above, we copy a document in our possession, which reads:

Purdue University, Lafayette, Indiana.

Upon the occasion of conferring the honorary degree of Doctor of Engineering upon Angus Sinclair, at the commencement exercises of Purdue University, held in the morning of June 10, 1908, President Stone spoke as follows:

The university takes honor to itself today in conferring the highest official recognition in its power to bestow upon one whose distinguished achievements in the field of engineering make him worthy of the highest honors.

Angus Sinclair, native of Scotland, adopted son of America, learned in the history and practice of engineering, editor and publisher of RAILWAY AND LOCOMOTIVE ENGINEERING, author of many standard treatises on railway engineering, influential leader and counsellor in engineering science.

Upon recommendation of the faculty and by the authority of the board of trustees, I do now confer upon Angus Sinclair the honorary degree of Doctor of Engineering in evidence of which this diploma is presented.

**Talk to Your Fireman.**

It is the duty of a locomotive engineer to show his ruling orders to his fireman. If you are ordered to side track at Springfield for No. 17, the fireman begins to figure on that. If he has a good steamer, he will permit his fire to burn low in nearing a meeting point to save fuel. If he has a poor steamer, he will scheme to keep the steam up to the meeting point, and in either case if the engineer push by, the fireman will be the first to notice it. It will not detract from the engineer's position to mix up a little socially with his fireman and it is calculated to make the fireman a good engineer.

The same rule requiring the engineer to show his orders to the fireman applies with equal force for the conductor showing his orders to his brakeman. There is strong sentiment to-day in favor of "Safety First," and we know of no means so efficient for safety as putting the train orders in the hands of all the train men. Had this practice been firmly adhered to in the past it would have prevented many severe accidents that brought death and suffering to many persons.

**A Self-Cleaning Sander**

The clogging of locomotive sand pipes need no longer be the abiding annoyance that it has been partly through the effect of sudden climatic changes and partly by reason of the careless handling of material by the cheaper class of labor employed in handling the supply of sand at the division points. About twenty-five American railroads have already tested a new device placed on the market by the White American Locomotive Sander Company, Roanoke, Va.

The accompanying illustration shows a section view of the device. It is usually placed directly under the runboard of the locomotive and is connected by a 1 1/4-in. iron pipe H to the sand box, and a 1 1/4-in. pipe I delivers the sand from the trap to the rail. Through the wall of the elbow casting A the air nozzle B is inserted. Another air con-

nection to the trap is made by means of a 1/2-in. air pipe C, from which two 1/8-in. pipe lines lead. One of these is the core X, the other is the small pipe E. The 1/8-in. pipe D screws into the core X, and rises from the trap through the sand pipe H to the sand box and is closed at the top, but at frequent intervals in this pipe D small holes are drilled at an angle and specially disposed around the pipe so that air admitted to it makes a whirling downward blast through the sand pipe to the trap. Communicating with the pipe C is the 1/8-in. air pipe E, which extends out 5 or 6 ins. into the sand delivery pipe I. This carries the cleaning blast to the sand delivery pipe.

In the event of the sand pipes becoming clogged, the engineer by means of a separate valve in the cab admits a blast of air to the auxiliary air pipe C, which instantly cleans out the entire pipe line both above and below the trap. A jam nut N regulates the amount of sand desired by means of the distance which the sanding nozzle B is inserted into the trap.

The device was in operation at the Supply Men's Exhibit at Atlantic City in June last, and attracted much attention. It is not only a perfect sander, but, what is also necessary, a perfect pipe cleaner. It may readily be applied to any type of locomotive without interfering in any way with the sand box.

**Roosevelt's Railroad Policy.**

Ex-President Roosevelt is prominently in the limelight at present, and we no-

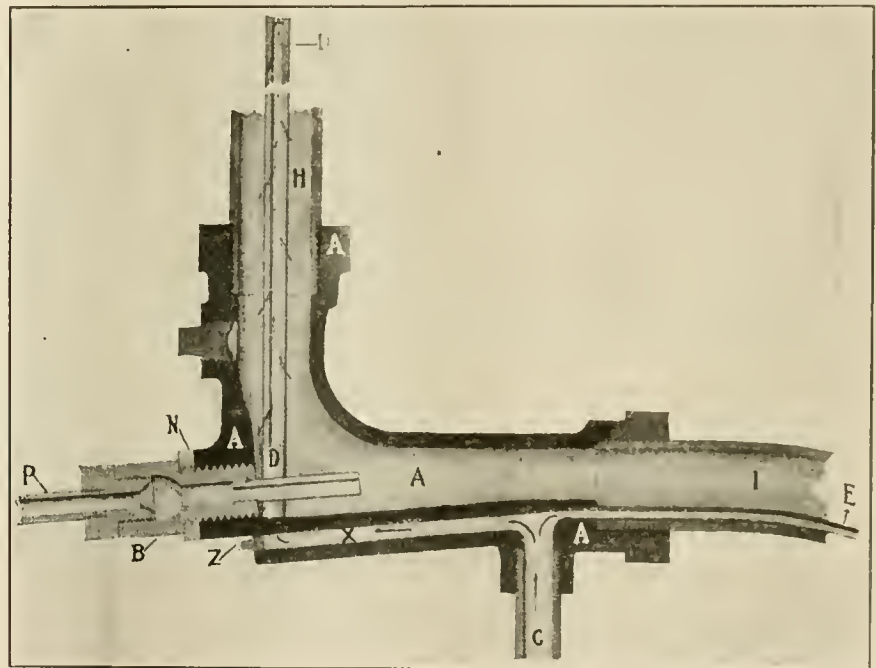

tion to the trap is made by means of a 1/2-in. air pipe C, from which two 1/8-in. pipe lines lead. One of these is the core X, the other is the small pipe E. The 1/8-in. pipe D screws into the core X, and rises from the trap through the sand pipe H to the sand box and is closed at the top, but at frequent intervals in this pipe D small holes are drilled at an angle and specially disposed around the pipe so that air admitted to it makes a whirling downward blast through the sand pipe to the trap. Communicating with the pipe C is the 1/8-in. air pipe E, which extends out 5 or 6 ins. into the sand delivery pipe I. This carries the cleaning blast to the sand delivery pipe.

In applying sand to the rail the engineer has only to open the valve in the cab and admit air into the 1/4-in. air

pipe P. In the event of the sand pipes becoming clogged, the engineer by means of a separate valve in the cab admits a blast of air to the auxiliary air pipe C, which instantly cleans out the entire pipe line both above and below the trap. A jam nut N regulates the amount of sand desired by means of the distance which the sanding nozzle B is inserted into the trap.

Every man, of course, is at liberty to favor or oppose any individual, but we think that railroad men generally profited from the policy recommended by Ex-President Roosevelt. In one of his messages to Congress, in dealing with loss of life on our railroads, he stated plainly that he considered that four essentials should be considered and embodied in the railroad legislation of the immediate future. They were compulsory adoption of the block system of railway signalling; the enforced limitation of the hours of continuous railway service; the employment of trained and experienced men only in positions of responsibility, and the severe punishment of all those who, by the issuance of wrong orders, or of those who, by the disobedience of orders, caused disasters.

# Items of Personal Interest

Mr. E. H. Pudney has been appointed supervisor of signals of the Atlanta & West Point.

Mr. F. S. Stuart has resigned as chief engineer of the Baltimore & Ohio to engage in engineering practice in New York City.

Mr. Arthur Engh has been appointed bridge engineer of the Chicago, Burlington & Quincy lines east of Missouri river, with offices at Chicago, Ill.

Mr. Charles W. Extrand, has been appointed road foreman of engines, on the St. Paul division of the Northern Pacific, with office at Northtown, Minn.

Mr. E. Weinhold has been appointed supervisor of equipment of the Evansville & Indianapolis, with headquarters at Greenwood Yard, Terre Haute, Ind.

Mr. A. West has been appointed district master mechanic, district No. 4, of the Canadian Pacific, with office at Edmonton, Alta., succeeding Mr. A. J. Ironsides, transferred.

Mr. F. F. Hanly, formerly assistant engineer of the Baltimore & Ohio at Baltimore, Md., has been appointed division engineer, with headquarters at Cumberland, Md.

Mr. D. W. St. Clair has been appointed master mechanic of the Missouri, Oklahoma & Gulf of Texas railway, with office at Denison, Tex., succeeding Mr. J. R. Greiner, resigned.

Mr. C. R. Knowles, formerly general foreman of the Illinois Central and the Yazoo & Mississippi Valley, has been appointed superintendent of water service, with offices at Chicago, Ill.

Mr. Arthur E. Owen has been appointed chief engineer of the Central of New Jersey, with offices at New York. Mr. Owen has been eighteen years in the engineering department of the road.

Mr. M. A. Daly, formerly fuel supervisor of the Northern Pacific at Tacoma, Wash., has been transferred to a similar position on the same road at St. Paul, Minn., succeeding Mr. G. T. Conley, resigned.

Mr. F. W. Wilson, formerly road foreman of equipment of the Chicago, Rock Island & Pacific at Rock Island, Ill., has been appointed engineer of fuel economy, with office at Chicago, succeeding Mr. H. Cleiner.

Mr. J. M. Buick, vice-president of the American Car & Foundry Company, has been appointed general manager, and Mr. William Hager, formerly secretary of the company, has been elected assistant to the president.

Mr. Henry Fischer, formerly sales agent of the Verona Tool Works, Pittsburgh, Pa., at Chicago, has been appointed general sales manager of the

company, with headquarters at Pittsburgh, Pa.

Mr. R. J. Himmelright has been appointed manager of the service department of the American Arch Company, New York, and Mr. J. T. Anthony has been appointed assistant to the president of the company.

Mr. A. M. Bears, signal supervisor on the Manitoba division of the Canadian Pacific, has been granted leave of absence for oversea service in the 12th Field Ambulance, with the Canadian expeditionary forces.

Mr. Robert Farnham, Jr., formerly assistant to the engineer of bridges and buildings of the Pennsylvania at Philadelphia, Pa., has been appointed engineer of bridges and buildings and the position of assistant has been abolished.

Mr. F. D. Grunder, formerly with the National Tube Company, as assistant general sales manager, has been appointed general manager of sales of the new tube department of the Jones & Laughlin Steel Company, Pittsburgh, Pa.

Mr. C. B. Woticky has been appointed electrical engineer of the Lehigh Valley, and Mr. D. J. Cartwright, formerly electrical engineer at South Bethlehem, Pa., has been appointed assistant electrical engineer, both with offices at South Bethlehem.

Mr. H. Cleiner, formerly superintendent of fuel economy of the Chicago, Rock Island & Pacific at Chicago, has been appointed master mechanic of the Missouri division of the same road, with office at Trenton, Mo., succeeding Mr. E. J. Harris, resigned.

Mr. E. J. Harris, formerly master mechanic of the Chicago, Rock Island & Pacific, at Trenton, Mo., has been appointed shop superintendent of the Denver & Rio Grande, with office at Salt Lake City, Utah, succeeding Mr. D. G. Cunningham.

Mr. R. N. Begien has been appointed chief engineer of the Baltimore & Ohio, with office at Baltimore, Md. Mr. Begien has also jurisdiction over the Cincinnati, Hamilton & Dayton. Mr. Begien has been in the engineering department of the company since 1902.

Mr. Aaron Dean, formerly resident manager of the New York office of the Union Switch & Signal Company, has been appointed special representative, with headquarters in New York, and Mr. W. P. Allen has been appointed resident manager of the New York office.

Mr. W. H. Keller, formerly general foreman of the Texas & Pacific at Fort Worth, Tex., has been appointed master mechanic of the eastern division, with office at Marshall, Tex., with jurisdiction extending over the shops at Texarkana,

Tex., where the office of master mechanic has been abolished.

Mr. D. G. Cunningham, formerly master mechanic of the Chicago, Rock Island & Pacific, Salt Lake City, Utah, has been appointed superintendent of motive power of the Denver & Salt Lake, with office at Denver, Colo. Mr. Cunningham has had a wide experience on a number of the leading railroads.

Mr. John F. Mullen has been appointed assistant master mechanic of the Buffalo, Rochester & Pittsburgh, in charge of the Buffalo division, with office at Buffalo Creek, N. Y., and Mr. Edward F. Houghton has been appointed superintendent of shops on the same road at East Salamanca, N. Y.

Mr. E. Sumner, formerly master mechanic on the Pennsylvania at the West Philadelphia shops, has been appointed superintendent of motive power on the same road, with offices at Williamsport, Pa. Mr. Sumner has been employed in the motive power department of the Pennsylvania over twenty years.

Mr. W. M. Post, formerly supervisor of signals of the Pennsylvania at Jersey City, has been appointed inspector of signals, with office at Philadelphia, Pa., and Mr. B. F. Osler, formerly supervisor of signals of the Manhattan division at New York, has been appointed supervisor of signals of the New York division. The Manhattan and New York divisions have recently been consolidated.

Mr. Oscar F. Ostby, formerly sales agent of the Commercial Acetylene Railway Light & Signal Co., New York, has been appointed general manager of the Refrigerator Heater & Ventilator Car Co., St. Paul, Minn. Mr. Ostby is very popular among railway men generally, and the Railway Manufacturers' Association particularly, of which he has just closed his term as a very efficient president. The best wishes of all his friends go with him in his new sphere of activity.

Mr. W. R. Hastings, formerly assistant signal engineer, first district, Chicago, Rock Island & Pacific, with headquarters at Des Moines, Ia., has been granted leave of absence. Mr. C. M. Duffy, formerly supervisor of signals of the Illinois division, with headquarters at Rock Island, Ill., has been appointed assistant signal engineer with jurisdiction over the second district and headquarters at El Reno, and Mr. C. E. Harting, formerly drafting engineer in the Des Moines office, succeeds Mr. Duffy at Rock Island.

Mr. Q. V. McQuilkin has been appointed storekeeper of the Baltimore & Ohio, at Baltimore, Md. Mr. McQuilkin entered the service as a clerk at Cumberland, in 1904, and has been in the continuous employ of the stores department,

at Keyser, W. Va., Baltimore and Pittsburgh. Mr. C. E. Cotton has been appointed storekeeper at Ivorydale, Cincinnati. Mr. W. H. Bowen has been appointed storekeeper at Clifton, New York, and Mr. J. C. McCaughan has been appointed storekeeper at Glenwood, Pittsburgh.

Mr. William R. Meeder, formerly master mechanic on the Chicago & Eastern Illinois at Danville, Ill., has been transferred to a similar position on the same road, with office at Villa Grove, succeeding Mr. R. N. Kincaid who has resigned to accept a position with the Buick Automobile Company, and Mr. William F. Heiser, formerly master mechanic at Evansville, Ind., has been transferred to Danville, succeeding Mr. Meeder, and Mr. Standipad, formerly general foreman at Salem, Ill., has been appointed master mechanic at Evansville, succeeding Mr. Heiser.

Mr. W. J. Bell, formerly supervisor of signals of the Pennsylvania at Media, Pa., has been assigned to the signal engineer's office, as the Media division is now consolidated with the Maryland division, and Mr. J. H. Broadbent, formerly supervisor of signals of the Williamsport division, has been appointed supervisor of signals of the new main line of the Baltimore division, with office at Baltimore, Md., and Mr. Guy Toft, formerly supervisor of signals of the old Baltimore division, has been appointed supervisor of signals of the Williamsport division succeeding Mr. Broadbent.

Mr. J. E. Toole, for the past six years traveling agent of the Traders Despatch Fast Freight Line, has resigned to accept a position in the sales department of the Pyrene Manufacturing Company, and will be connected with the company's Columbus, Ohio, office. Mr. Toole, in addition to being a railway traffic man, has been greatly interested in the problem of fire prevention, and has given up many of his vacations during the last few years to attend the annual conventions of the International Association of Fire Engineers, the membership of which is made up largely of chiefs of fire departments.

Mr. M. M. McCallister, inspector of building shops at Schenectady and Lima for the New York Central Railroad, has been appointed boiler inspector of the American Flexible Bolt Co., with headquarters at Pittsburgh, Pa. Mr. McCallister was born at Curleystown, Pa. He began his business career as the first apprentice on the Pittsburgh & Lake Erie. When he left that road he was made field erector of the James P. Witherow Co., of New Castle, Pa., manufacturers of the Heine boilers. From this position he went with the American Bridge & Iron Co. in charge of the Roanoke, Va., shops, and later to the Norfolk & Western as assistant foreman of

shops at Roanoke. He was next appointed assistant superintendent of the Richmond shops of the Richmond Locomotive Works, now a part of the American Locomotive Co. From here he left to become foreman boilermaker of the Lake Shore & Michigan Southern at Collinwood, Ohio. He was next appointed superintendent of the Erie City Iron Works, at Erie, Pa., leaving this position later to go as superintendent of John Brennan & Co., at Detroit, Mich., who manufacture stationary and marine boilers. He was next appointed superintendent of the Weil Boiler Co., with headquarters at Indianapolis, Ind. While here he designed and put on the market the Weil Smokeless Boiler, which has since proven a great success. From this position he went with the New York Central, which he now leaves to become boiler expert of the American Flexible Bolt Co.



JOSEPH RAMSEY.

#### OBITUARY

##### Joseph Ramsey.

Joseph Ramsey, Jr., well known as a railroad president, died suddenly at his home in East Orange, on July 7, from a stroke of apoplexy. Although he held official positions on many railroads, his most noted position was connected with the Wabash-Pittsburgh terminal, which was built to give the Gould system an entrance into Pittsburgh. In carrying out this part of his life's work, Mr. Ramsey came into conflict with Pennsylvania Railroad interests and came out second best.

Joseph Ramsey, Jr., was born in Pittsburgh, Pa., in 1850, and was educated at Western University, and began railroad work in 1869 in the engineering corps of the Big Four Railroad. From that time he had a highly varied career, mostly connected with engineering, but was several

times an operative officer. At the time of his death he was president of Lorain, Ashland & Southern.

#### Mechanical Association Committees.

The joint meeting of the Executive Committees of the Master Car Builders and of the American Railway Master Mechanics' Associations were held in New York on July 25.

The Master Car Builders was represented by C. E. Chambers, superintendent of motive power, Central Railroad of New Jersey; T. W. Demarest, superintendent of motive power, Pennsylvania Lines; James Coleman, superintendent of car department, Grand Trunk Railway; J. S. Lentz, master car builder, L. V. R. R.; F. F. Gaines, superintendent of motive power, Central of Ga. Ry.; J. S. Downing, master car builder, C. C. C. & St. L. Ry.; Samuel Lynn, master car builder, P. & L. E. R. R.; G. W. Wildin, mechanical superintendent, N. Y., N. H. & H. R. R.

Master Mechanics' Association was represented by Wm. Schlafge, general mechanical superintendent, Erie; F. H. Clark, general superintendent of motive power, B. & O. R. R.; C. F. Giles, superintendent machinery, L. & N. R. R.; Angus Sinclair, New York; M. K. Barnum, B. & O.; C. H. Hogan, N. Y. C.; J. T. Walters, P. R. R.; M. A. Kinney, Hocking Valley.

The principal business done was the appointment of committees to carry on the business of the association for next year. We will give full particulars in our next issue.

#### American Electric Railway Association Convention.

The exhibit committee of the American Electric Railway Association is now actively engaged with plans for the exhibit in connection with the coming convention to be held at Atlantic City, N. J., October 9 to 13, and is completing its arrangements with the various contractors who are to look after the erection of booths, decorations, furniture, etc. The exhibition promises to be the most interesting held under the auspices of the association.

#### Automobile Accident.

The many friends of Mr. R. W. Benson of the American Flexible Bolt Company, Pittsburgh, Pa., are grieved to learn of a serious automobile accident whereby Mr. Benson had his right wrist fractured, besides other damages. It appears that the chauffeur stopped the machine suddenly on observing a deep cavity in the road, throwing out the occupants of the car with considerable violence. Mr. Benson has been in the Pittsburgh Hospital for several weeks, but expects a complete recovery in a few months.

### International Railway General Foremen's Association.

The annual convention of the above association will be held on August 29-30-31 and September 1, at the Hotel Sherman, Chicago, Ill., and indications point to a very large attendance.

In addition to the general routine there are four very live topics which will be presented by able committees, and the association is assured of four excellent papers, which will bring forth valuable discussions.

The first topic, that of "Car Department Problems," is of great importance to general foremen. While it might look as though we were encroaching upon the other fellow's territory, that of the Car Department organization, yet the general foremen should be thoroughly versed in the repairs and maintenance of cars. He may not be so vitally interested during his tenure of office as general foreman, but in the natural order of events, he becomes a master mechanic, then when he sees the necessity of being posted on car problems. Mr. E. E. Griest, master mechanic of the Pennsylvania Lines West, Fort Wayne, Ind., will have charge of this topic.

Topic No. 2, "Counterbalancing of the Locomotive, and Fitting Up of Frames and Binders." Enough consideration is not given this class of work, yet here lies the foundation of the locomotive. If enough attention is not given to the balancing of the driving wheels, pounds will soon develop, road beds destroyed from multitudes of hammer blows. Poor fitting binders soon become loose, causing undue strains which sooner or later develop into broken frames, broken driving boxes, etc. This topic is in charge of Mr. H. C. Warner, shop superintendent, L. S. & M. S. Ry., Elkhart, Ind.

Topic No. 3, "Classification of Repairs," is a very broad subject, and should bring out the methods of the different railroads in arriving at the cost of repairs and mileage made. Various methods are in vogue and perhaps some recommendations may be made to adopt a standard classification of repairs that will be just to all concerned. This will prove to be an interesting topic for discussion, and will be presented by Mr. C. S. Williams, of New York Central Ry., Dunkirk, N. Y.

Topic No. 4, "Relation of the Foreman to the Men." This is a very important matter, upon it depends largely the discipline of the shop, also the output of the shop is in many instances increased or decreased as the foreman treats the men under his charge; in other words the treatment accorded the men by the foreman is reflected in the efficiency of his shop. This paper will be ably handled by Mr. T. E. Freeman, D. & I. R. Ry., Two Harbors, Minn.

All communications in regard to the convention should be addressed to Mr. Wm. Hall, secretary-treasurer, Chicago & North Western Railway, Winona, Minn.

### The Traveling Engineers' Association.

The next annual convention of The Traveling Engineers' Association will be held at Chicago, Ill., on September 5, 1916, and continue during the succeeding three days. The association is in a flourishing condition. The membership at last report was 1,061. The balance in the treasurer's hands amounted to over \$7,500. Mr. J. R. Scott, of the St. Louis & San Francisco, is president, and Mr. W. O. Thompson, of the New York Central, secretary.

The following are the list of subjects to be presented by special committees, and discussed by the members:

"What effect does the mechanical placing of fuel in fire-boxes and lubricating of locomotives have on the cost of operation."

"The advantages of the use of superheaters, brick arches and other modern appliances on large engines, especially those of the mallet type."

"Difficulties accompanying the prevention of dense black smoke and its relation to cost of fuel and locomotive repairs."

"Recommended practice in the make-up and handling of modern freight trains, on both level and steep grades, to avoid damage to draft rigging."

"Assignment of power from the stand-points of efficient service and economy in fuel and maintenance."

### American Boiler Manufacturers' Association.

At the recent convention of the above association the following were elected as officers for the current year: President, M. H. Broderick, Broderick Company, Muncie, Ind.; vice-president, C. V. Kellogg, Kewanee Boiler Company, Kewanee, Ill.; secretary and treasurer, H. N. Covell, Lidgerwood Company, Brooklyn, N. Y.; executive committee, G. S. Barnum, Bigelow Company, New Haven, Conn.; E. C. Fisher, Wickes Boiler Company, Saginaw, Mich.; Isaac Harter, Jr., Babcock & Wilcox Company, New York, and L. Mohr, Kewanee Boiler Company, Kewanee, Ill.

### Removal.

The St. Louis, Mo., offices of the Westinghouse Air Brake Company and Westinghouse Traction Company, Mr. C. P. Cass, southwestern manager, have been removed from the Security building to Suite 1407-1415 Boatmen's Bank building, St. Louis, Mo.

### Railroad Notes.

The Canadian Pacific is seeking to purchase 30,000 tons of rails.

The Delaware & Hudson Company has ordered one private car from the Pullman Company.

The Pennsylvania Railroad Lines East of Pittsburgh, is reported in the market for 5,000 70-ton hopper cars.

The Duluth, Winnipeg & Pacific is reported to have ordered 750 box cars from the Haskell & Barker Car Company.

The Solway Process Company, Syracuse, N. Y., has ordered 15 gondola cars from the Pressed Steel Car Company.

The Gadsden Car Works, Gadsden, Ga., is inquiring for 1,400 center constructions, 1,000 for box cars and 400 for furniture cars.

The United States Government is reported to have ordered a hospital train of 10 specially designed cars from the Pullman Company.

The Wheeling & Lake Erie will build a two-story Y. M. C. A. house for the benefit of its employes at Brewster, Ohio, at a cost of \$40,000.

The Chicago, Milwaukee & St. Paul has placed an order for 1,100 42-foot box cars of 40 tons capacity, to be built in its own shops at Milwaukee, Wis.

The Erie Railroad plans the erection of a locomotive terminal including engine house and repair shops on the meadows between Jersey City and Newark, N. J.

The Intercolonial Railway has undertaken the building of a station, viaduct and train shed at Levis, Quebec, to replace the facilities destroyed about a year ago.

The Havana Central is reported to have ordered 150 box cars and 50 flat cars, each of 30 tons capacity, as well as ten cabooses from the Standard Steel Car Company.

The Russian Government orders for railway material are stated to include 50,000 tons of spikes and bolts, 28,000 tons of steel axles and 56,000 tons of cast iron wheels.

The New York Central is in the market for five Pacific type locomotives. It is understood that these engines will be bought for the Cleveland, Cincinnati, Chicago & St. Louis.





## Long Time Protection

is given to steel cars, bridges, water and locomotive tanks, signal apparatus and all exposed metal and woodwork by

# DIXON'S SILICA GRAPHITE PAINT

The LONGEST SERVICE paint. Nature's combination of flake silica-graphite, mixed with pure boiled linseed oil, is the ideal combination which forms a firm elastic coat that will not crack or peel off. This prevents access to agents which corrode and injure the metal. Dixon's Silica-Graphite Paint is used throughout the world by railroad engineers.

Write us for long service records and booklet No. 69 B.

Made in JERSEY CITY, N. J., by the

**Joseph Dixon Crucible Company**

ESTABLISHED 1827

The Pennsylvania Railroad has received bids on material for construction of a coal trestle, ash pit and crane runway at the Reed Street freight yard, Philadelphia.

Great Britain, after placing orders for 50,000 tons of rails with the United States Steel Corporation during the past three months, is in the market for further tonnage.

The Alabama Great Southern has ordered 695 30-ton steel center sill box cars and 100 30-ton steel center sill automobile cars from the American Car & Foundry Company.

The Chicago & Alton has under advisement the matter of converting some 50 of its present freight equipment cars in such manner as to adapt them to the handling of automobiles.

The Cincinnati, New Orleans & Texas Pacific has ordered 1,409 30-ton, steel center sill box cars and 200 30-ton steel center sill automobile cars from the Mt. Vernon Car & Mfg. Company.

The Rhodesia Railways has ordered six mountain (4-8-2) type locomotives from the American Locomotive Company. The engines will have cylinders 23 by 24 inches and a total weight of 172,000 pounds.

The Alabama Great Southern has ordered six Mikado (2-8-2) type locomotives from the Lima Locomotive Corporation and two mountain (4-8-2) type locomotives from the Baldwin Locomotive Works.

The United States Steel Corporation has divided an order for 448 cars for the Carnegie Steel Company among the Pressed Steel Car Company, the Standard Steel Car Company and the American Car & Foundry Company.

The Cincinnati, New Orleans & Texas Pacific has ordered five mountain (4-8-2) type locomotives from the Baldwin Locomotive Works and four eight-wheel (0-8-0) switching locomotives from the Lima Locomotive Corporation.

The Baldwin Locomotive Works is reported to have received an order for 100 small field locomotives for the French Government of the same type as those ordered last year, and to be delivered within the next three months.

The Togoland Military Railway, of Africa, has ordered two Mikado locomotives from the American Locomotive Company. These locomotives will have 15 by 20-in. cylinders, 38-in. driving

wheels and a total weight in working order of 96,000 lbs.

The Cincinnati, New Orleans & Texas Pacific has ordered 12 steel passenger coaches, three steel combination passenger and baggage cars, six steel combination baggage and express cars and one steel dining car from the Pullman Company.

The Bangor & Aroostook has ordered one superheater Consolidation locomotive from the American Locomotive Company. This locomotive will have 23 by 30-in. cylinders, 56-in. driving wheels and a total weight in working order of 208,000 lbs.

The Southern Pacific has given an order for 80,000 tons of rails to the Tennessee Coal, Iron & Railroad Company, for delivery from April to September, 1917. The Southern Pacific is understood to be in the market for an additional 50,000 tons.

The Union Switch & Signal Company, Swissvale, Pa., has been awarded a contract to furnish the material to equip the Atlanta & West Point with automatic block signal system and other signaling and safety devices. The distance is about 33 miles.

The United States Steel Corporation has placed an order for 448 freight cars for the Carnegie Steel Company. The order, it is understood, was distributed between the Pressed Steel Car Company, the Standard Steel Car Company and the American Car & Foundry Company.

The Canadian rail manufacturers, unable to secure sufficient quantities of raw materials or of billets, are offering to sublet to producers in the United States orders for 35,000 to 40,000 tons of rails. All available output of this country, however, is believed to be taken for at least the next nine months.

The Central Railway of Brazil has ordered from the American Locomotive Company two Pacific (4-6-2) type and 12 10-wheel (4-6-0) type locomotives. The Pacific engines will have cylinders 21½ by 28 inches and a total weight of 207,000 pounds. The 10-wheel engines will have cylinders 21½ by 28 inches and a total weight of 175,000 pounds.

The New York Central has contracted with the Federal Signal Company for the installation of an electric interlocking plant at Utica, N. Y., with a machine of 180 levers. There will be 143 working levers for the control of 76 signals, 51 switches and 16 check locks. The signals will be Type 4. New York Central standard will govern throughout, including the use of concrete trunking and stakes.

## Books, Bulletins, Catalogues, Etc.

### Locomotive Superheaters.

LOCOMOTIVE SUPERHEATERS: INSTRUCTIONS FOR INSTALLATION, OPERATION, MAINTENANCE AND REPAIRS. Published by the Locomotive Superheater Company, 30 Church street, New York. 48 pages. 50 illustrations.

The Locomotive Superheater Company has made a notable contribution to railroad literature by the issuance of an instruction book furnishing complete details of every part of the superheating device as applied to locomotives. A work of this kind was needed and might have been published before, but the company acted wisely in delaying the matter until that degree of perfection in the details of the application was reached that places it on a basis where any further improvement can not be expected. As we have repeatedly stated, the superheating appliances as perfected by the enterprising company has shown its superiority under the most exacting conditions. A number of its finer details are peculiarly American, and particularly adapted to the high-powered heavy locomotives that have come into use of recent years. Indeed, so complete have the details of the device been mastered that in running the modern locomotive one is hardly aware of the presence of the important improvement that adds, generally speaking, at least one-third to the hauling capacity of the engine.

After a general description of the device, special instructions are given in flue setting, the tools used, detailed drawings of which will be furnished upon request to the New York office, and the handling of the tools. This latter is important, as much damage has been done by the improper use of beading and other tools. The proper placing of bands and supports on the unit pipes is also of importance, and instructions are presented of the best means and methods of placing the supports in such a position as to relieve all unnecessary strain. The tightening of the units, although apparently simple, is also a matter requiring skill, which is easily acquired by reading the instructions, and exactly following the same.

In regard to grinding the joints of the units the company has recently developed grinding forms admirably adapted for the purpose. These grinding forms are easily made in moulds from any of the soft metals or scrap metallic piston and valve rod packing. The metal is melted in any convenient manner and poured rapidly into the top of the mould until the mould is full. The casting is readily freed by unscrewing the top of the mould. Carborundum or any of the ordinary grinding materials may be used with all these forms in a manner similar to that practiced in grinding injector or other

joints. The contour of these moulds is exactly suited to the pipe joints, and there is neither waste of time or material in making a perfect joint.

The subject of inspection is also fully treated, and the need of a thorough tightening of all unit bolts after the engine has made two or three trips is pointedly dwelt upon. The fitting of the deflector plates and top clamp is described which will permit the removal of the deflector plates without removing the netting.

The proper lubrication of steam chests and cylinders with details of connections and a description of the correct piping, which requires all pipes to have a gradual drop from the lubricator to the discharge end without pockets or horizontal sections, as the latter become pockets when the engine is headed up a grade, is all set forth with a degree of clearness that is simplicity itself. The location of the damper cylinder and the damper with the proper adjustments is also made plain, so that every jointed part of the appliance is laid bare, as it were, and its proper adjustment fully explained.

The valuable instructions in regard to operation, drifting, firing, maintenance and repair have each separate sections of instructions, so that nothing is left to chance, or what is sometimes worse to instruction by those who may be in need of instruction themselves. Under maintenance and operations there are several sections devoted to cleaning, cutting out of flues, cleaning in rattler and safe ending, all of which are of importance in their way.

A part of the instruction book is also devoted to cylinder and valve packing rings, and valve bushings, the various amounts of clearance between the ends of the packing for the various sizes of cylinders being given, the amount depending on the diameter of the bore. The same care has been taken in describing piston rod and valve stem packing, and the alloys that have stood the best tests are described, as well as the details of the emergency clamps and washers that are essential to a complete equipment. Indeed, it seems as if nothing in any way connected with the appliance has escaped notice in the work before us, and if we have dwelt longer upon its features than is usual in books of this kind, it is because we realize in a large degree the need of such a work, and the complete measure of its fulfillment of its purpose, and in this regard the company is to be congratulated on its publication as well as those interested who, we understand, may have copies of the instruction book on application to either the main office at New York or at the Chicago office, Peoples Gas building.

# GOLD Car Heating & Lighting Company

Manufacturers of

ELECTRIC,  
STEAM AND  
HOT WATER  
HEATING  
APPARATUS  
FOR RAILWAY CARS  
VENTILATORS  
FOR PASSENGER  
AND REFRIGER-  
ATOR CARS  
ACETYLENE SYSTEM  
OF CAR LIGHTING

Send for circular of our combination PRESSURE AND VAPOR SYSTEM OF CAR HEATING, which system automatically maintains about the same temperature in the car regardless of the outside weather conditions.

Main Office, Whitehall Building  
17 BATTERY PLACE  
NEW YORK

# Hydraulic

**Riveters Fixed and Portable  
Punches, Shears,  
Presses, Lifts, Cranes  
and Accumulators.**

**Matthews' Fire Hydrants,  
Eddy Valves  
Valve Indicator Posts.**

The Camden High-Pressure Valves.

## Cast Iron Pipe

**R. D. Wood & Company**

Engineers, Iron  
Founders, Machinists.

100 Chestnut St., Philadelphia, Pa.

**Nichols Transfer Tables  
Turntable Tractors**  
GEO. P. NICHOLS & BRO.  
1090 Old Colony Bldg. CHICAGO

For Testing and Washing  
Locomotive Boilers

USE THE

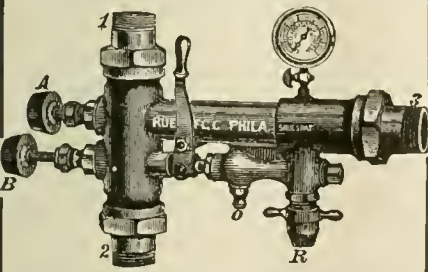

**Rue Boiler Washer  
and Tester**

SEND FOR CATALOGUE

**Rue Manufacturing Co.**  
228 Cherry Street Philadelphia, Pa.  
Manufacturers of Injectors, Ejectors,  
Boiler Washers and Testers, Boiler Checks,  
Check Valves.



**ASHTON**  
**POP VALVES AND GAGES**  
The Quality Goods That Last  
The Ashton Valve Co.  
271 Franklin Street, Boston, Mass.  
No. 174 Market St., Chicago, Ill.

**INDUSTRIAL ORGANIZATION AND MANAGEMENT.** By Hugo Diemer, B.A., M.E., Chicago: LaSalle Extension University, 1915. 8vo.; 291 pp.; illustrated. Price, \$2.

In this interesting book are ably summarized and illustrated three underlying principles which have come to be recognized, as the essential elements of the new industrial efficiency, from the broad fundamentals of sound organization, satisfactory location, and well-planned buildings and equipment, to actual operation in all its branches—buying, receiving and storage of materials, the planning of finances, sales, production, work, and employment, cost determination, distribution of expense, and standardization. The subject of scientific management is then taken up; time and motion studies and wage systems are considered, and employment problems are solved. Diagrams and charts are displayed in profusion; the very latest methods of motion study, such as that which photographs the movements of an electric light attached to the hand of the workman, are explained; in short, the volume is a complete exposition of the latest practice, methods, and devices used to increase both quality and quantity of output while at the same time improving working conditions for the individual. The author is a well-known consulting engineer, not a mere theorist, and his interpretation of the new movement, with his concrete examples and his arguments based upon actual achievements, is extremely clear and commendable.

### Smithsonian Report.

Report of the Smithsonian Institution, 544 pages, with illustrations. Washington Government Printing Office.

The appearance of this work is always a red letter day in the annals of Government publications. It is like a green spot in the sandy desert of Government reports. It is an epitome of the scientific progress of our time. The contributors are in the front rank of earnest investigators. The subjects are of world-wide interest. It would be impossible to reprint the list of subjects in our limited space. They run from the constitution of matter and the evolution of the elements, to the linguistic areas in Europe—their boundaries and their political significance. Of real interest to railway men is the report on "Some recent developments in telephony and telegraphy," as also the "Clearing of fog by electrical precipitation." The report on the "International catalogue of scientific literature," is also full of interest. Copies may be had on application, usually through members of Congress, and as the national election is near at hand members of either house of representatives will be pleased to oblige their constituents, especially before the next election.

### Gold Systems.

The Gold Car Heating & Lighting Company, New York, has just issued a catalogue describing and illustrating steam, vapor, hot water and electric systems for heating and automatically controlling the temperature of all types of railway cars. It extends to 144 pages and is profusely illustrated in the highest style of the art. No other issue has shown so many improvements of real value. The development of the various systems has reached a degree of perfection, especially in point of simplicity, that meets with universal approval. The M. C. B. standards are adhered to in all cases. In point of economy extensive tests have been shown that the thermostatic control device developed by the company has cut down the steam or electric consumption at least one half. In the wide sphere of couplers, and accessories generally, the engineering department of the enterprising company has left nothing further to be desired. As a matter of mutual protection the company recommend that all material for repairs when necessary should be procured through the company's officers. They will be found to be cheapest and best. Copies of this catalogue should be in the hands of all interested in the heating or ventilating of cars. Address the main office, 17 Battery Place, New York.

### Axles and Forgings.

The Carnegie Steel Company, of Pittsburgh, Pa., has issued the seventh edition of "Axles and Forgings for Steam and Electric Railway Service." The pamphlet indicates briefly the character of the work the company is equipped to do at its axle and forging plants, as well as presents in full certain standard specifications and axle designs for the guidance of prospective purchasers. There are appended tables of weights of rounds, which will be found useful in estimating weights of axles and forgings, and decimal conversion tables.

### Duntley Electric Tools.

The Chicago Pneumatic Tool Company, manufacturers of Duntley Electric Tools, and also a complete line of pneumatic tools and appliances in a Bulletin E 41, describe and illustrate a line of portable electric tools designed especially for use on railways. A track drill built for rapid work in rail bonding, drilling tie and joint holes and for reaming joint holes is made in three sizes, and has several new features, among which is a side spindle feature permitting drilling close to the ties. The portable grinders also are meeting with much favor; the electric spike driver has introduced the screw spike. Every one who has had the opportunity of observing this innovation admits its superi-

ority over the old hammer driven spike. There is no tendency to mutilate the fibre of the wood, and the holding capacity is conservatively estimated at four times that of the plain spike. Other devices equally ingenious and labor saving and cost reducing are recorded in the bulletin, a copy of which may be had on application to the company's main office, Fisher building, Chicago, Ill.

#### Engineering in Foreign Fields.

The J. G. White engineering companies have issued an illustrated bulletin showing the remarkable development of construction work in all parts of the world. As an object lesson in the possibilities of American enterprise abroad it marks a departure hitherto unattained and gives promise of what the future may unfold. In the department of steam and electric railways alone the enterprising firm may be said to have reached the far ends of the earth. Their engineers are everywhere. While we are not surprised to see among the illustrations a network of railroad construction work in the South American republics, we were hardly aware of the magnitude of railroad work already accomplished by the White companies in the British Empire. In the atmosphere of American enterprise old world means and methods must stand aside, and there is no better proof needed that this is the age of the perfection of mechanism and America is the country where it is blossoming in its highest degree of perfection, than a look through this interesting bulletin, a copy of which may be had on application at the Company's office, 43 Exchange Place, New York.

#### Accident Bulletin.

There is some hope of the *Accident Bulletin* issued by the government printing office coming a little nearer the present time. At present it is only nine months behind time. It used to be—but what is the use of calling up ancient history. The report for July, August and September, 1915, is before us, with its record of accidents on railways during that period. From this report the total number of persons reported killed in all classes of accidents was 2,531 and the number of persons injured 43,518. This includes 2,286 killed and 12,935 injured as the result of accidents sustained by employees while at work, by passengers getting off and on cars, by persons at highway crossings, by persons doing business at stations, etc., as well as by trespassers and others; and also 118 persons killed, and 28,746 persons injured in casualties, reported as non-train accidents. Briefly it is proper to note that while the miles of track and amount of equipment is increasing, the accidents to persons are diminishing.

#### The Sweeley Graphite Lubricator.

Graphite for July has the following interesting item: One of the interesting tests that we are now running with Sweeley Locomotive Graphite Lubricators is a locomotive on one of the large eastern systems in very hard service. The Sweeley Lubricator is under test on one side only, while the other side of engine is working with ordinary oil lubrication. An interview recently with the locomotive engineer running this engine developed the fact that the engineer himself is so much in favor of the device that he stated he would be willing to buy the graphite himself if they would equip his engine on the other side with another Sweeley Lubricator. There are other items equally interesting in this interesting publication. Get a copy from the Joseph Dixon Crucible Co., Jersey City, N. J.

#### Steel and Steel Frame Cars.

Bulletin 79 of the Special Committee on Relations of Railway Operation to Legislation of the American Railway Association conveys the following information in regard to the construction and use of steel and steel underframe passenger train equipment:

The number of wooden cars in service, January 1, 1912, was 48,126. There are now in service approximately 41,382, indicating the retirement from service of 6,744 cars in three years. On January 1, 1909, approximately 629 steel and 673 steel underframe cars were in service, while on January 1, 1916, there were approximately 14,286, all steel and 6,060 steel underframe cars in service. There were only three wooden passenger cars under construction, January 1, 1916. There were under construction on the same date 1,091 steel and steel underframe cars.

This data is furnished by 290 roads operating 236,167 miles in the United States and operating 61,728 passenger train vehicles. The bureau estimates that to change or replace the present wooden equipment amounting to 41,382 cars, would involve an expense of \$528,787,100 with an annual interest charge of five per cent., or \$26,439,355. Under classification accounts of the Interstate Commerce Commission, the charge to operating expenses assumes a value of \$4,000 per vehicle replaced, and would be \$165,528,000.

#### Reciprocity.

To get more, you must deliver more; that is one of the fundamental laws of business, and to deliver more, you must have more in you—more in your brain than you had yesterday or the day before, or the day before that.

**STEEL STAMPS**  
INSPECTORS HAMMERS  
Hand Cut STEEL LETTERS & FIGURES  
LATHE TOOLS, TIME CHECKS,  
Noble & Westbrook Mfg. Co.  
9 ASYLUM ST. HARTFORD, CONN.

### Locomotive Engine Running and Management

By ANGUS SINCLAIR

This popular book has been a RELIABLE REFERENCE and comfortable unfailling POCKET EDITION.

PRICE, \$2.00

ANGUS SINCLAIR CO.  
114 Liberty St., New York



You Want Tool Holders That Have Made Good



ARMSTRONG TOOL HOLDERS WERE AWARDED THE GRAND PRIZE

The Highest Possible Award at the Panama-Pacific International Exposition  
THEY ALWAYS MAKE GOOD



ARMSTRONG BROS. TOOL CO.  
"The Tool Holder People"  
312 N. Francisco Ave., Chicago, U. S. A.

ENAMELED IRON FLUSH OR DRY CLOSETS  
**DUNER CAR CLOSETS**  
DUNER CO.  
116 S. CLINTON ST., CHICAGO

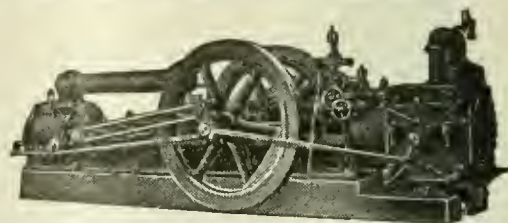

**The Norwalk Iron Works Co.**  
SOUTH NORWALK, CONN.  
Makers of Air and Gas Compressors  
For All Purposes  
Send for Catalog

# Railway AND Locomotive Engineering

A Practical Journal of Motive Power, Rolling Stock and Appliances

Vol. XXIX.

114 Liberty Street, New York, September, 1916.

No. 9

## Two Hundred Ton Hydraulic Press in Operation

Our frontispiece shows a reproduction of a photograph of a hydraulic press manufactured at the works of Mr. William H. Wood, the well known constructor of hydraulic and other machinery, Media, Pa. One cannot fail to be struck with the symmetry of the design, and

placed him in the front rank of American constructing engineers.

As will be readily observed the machine is adapted for the heaviest kind of flange forming and other work where steel or iron plates are pressed into the forms necessary for boilers and other

of vertical plungers, 2 ft. 6ins. Diameter of vertical plungers, 13 $\frac{3}{4}$  ins. Stroke of horizontal plunger, 18 ins. Diameter of horizontal plunger, 8 ins. Stroke of vertical plunger in base, 20 ins. Diameter, 8 ins. Diameter of pull back ram, 6 $\frac{1}{2}$  ins. Chain links on pulleys operating

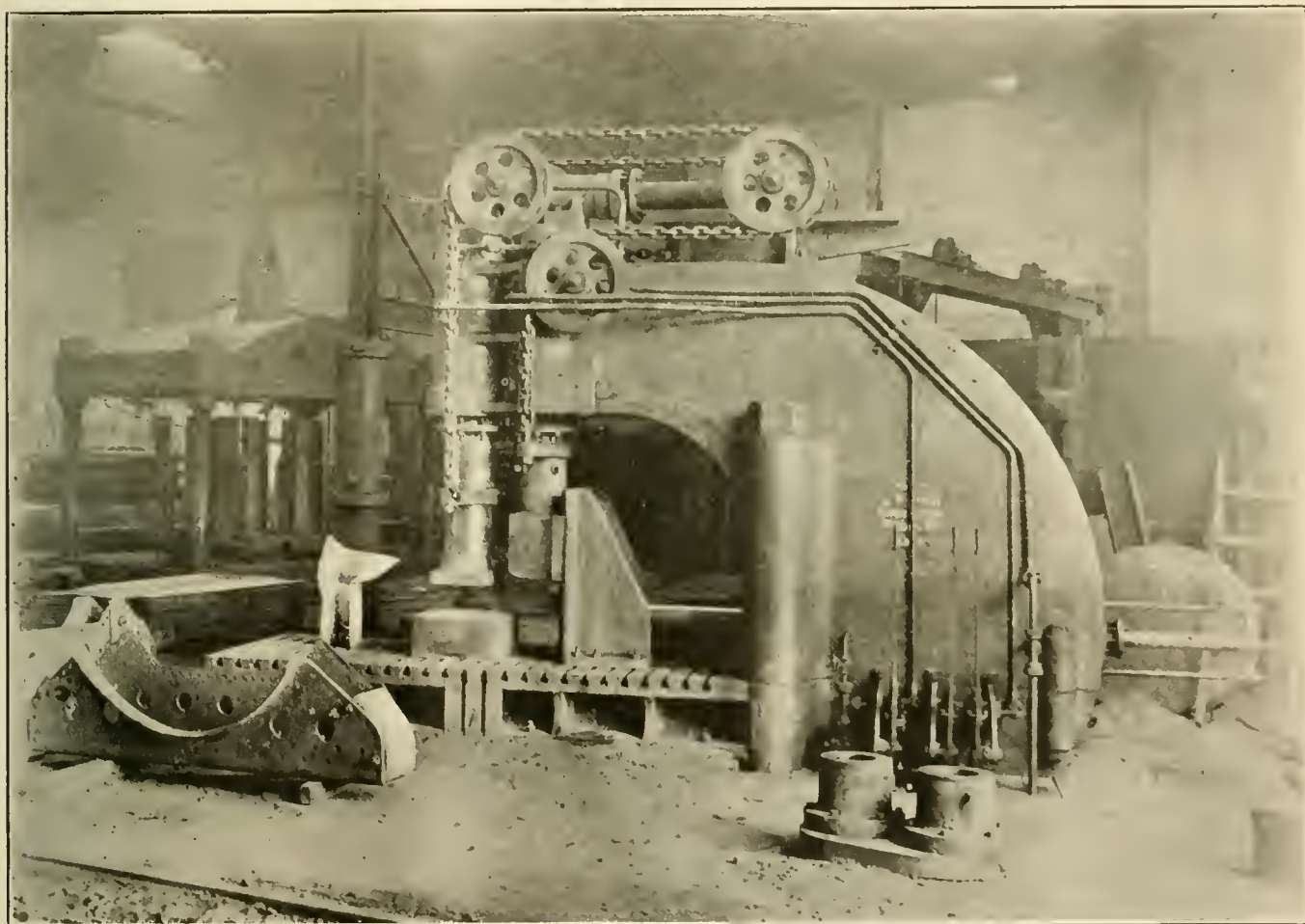

POWERFUL HYDRAULIC PRESS IN THE CASEY-HEDGES, CHATTANOOGA, TENN., SHOPS.

the fact that even the most ponderous and powerful machinery can be built on lines that are at once pleasing to the most fastidious eye, and at the same time lose none of the power necessary for the work for which it is designed. Mr. Wood's long and varied experience in this class of engineering construction has

heavy sheet metal work. The machine is now in operation in the Casey-Hedges, Chattanooga, Tenn., and other well known shops, where they are meeting the requirements. The general dimensions are:

Height from floor, 12 ft. 6 ins. Length, 18 ft. 6 ins. Width, 5 ft. 6 ins. Stroke pull back ram 1  $\frac{1}{16}$  ins. in diameter.

The press can be operated on forming boilers by sectional formers up to 20 ft. in diameter, and will flange and dish a boiler head 6 ft. 4 ins. in diameter,  $\frac{5}{8}$ -in. in thickness at one operation. The accumulated pressure is rated at 1,500 lbs. per square inch. The total capacity of the press being 200 tons.

# The Rebuilding of a Western Railroad

## Past and Present of the Chicago Great Western

It is well to remember now that a new era of activity has set in in American industries generally and railroads partic-

determination of the men who worked heroically through the dark days was not unobserved. The possibilities were not

monly called loose change. It was capital looking for investment. There was seventeen millions of it. It was like the

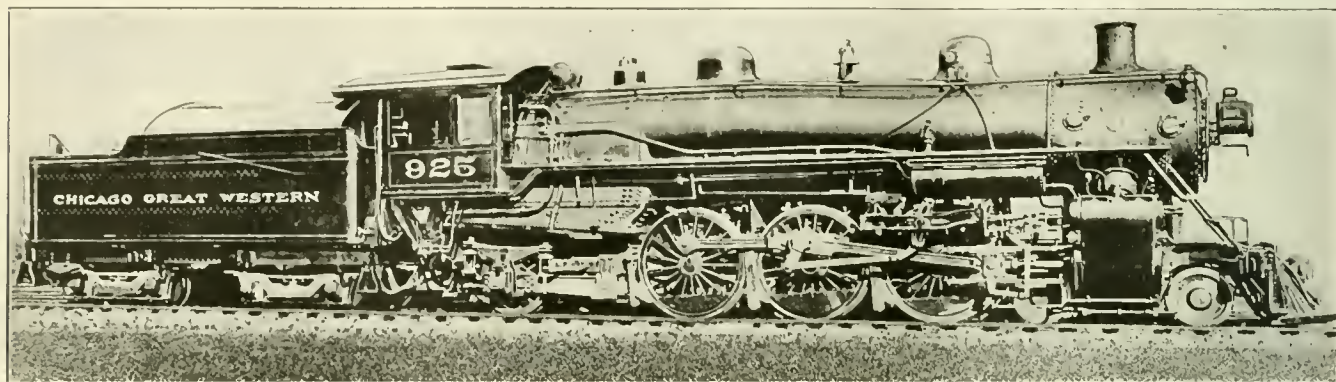

PACIFIC TYPE OF LOCOMOTIVE ON THE CHICAGO GREAT WESTERN RAILROAD.

ularly, that even during the darkest days of financial depression and legislative repression, there were enterprising spirits gifted with the vision of the future, and who saw with the eye of faith all the wonder that would be. No better proof of this could be found than a brief glance at the modernizing of a railroad as shown in the rebuilding and the re-equipment of the Chicago Great Western Railroad. Only a few years ago, in passing over it we observed that it had all the ear marks of financial decrepitude. The grass grew on its poorly ballasted track. The signals of red ruin lit the gloomy pathway from sleepy town to town. The passionate exhaust of the overworked locomotives that wended their weary way through the thinly populated region was accompanied by the clanging of the loose jointed connecting rods, that sounded more like a busy blacksmith's shop on wheels than a twentieth century locomotive at work. It was not the only railroad that had its trials and troubles. Expenses were large

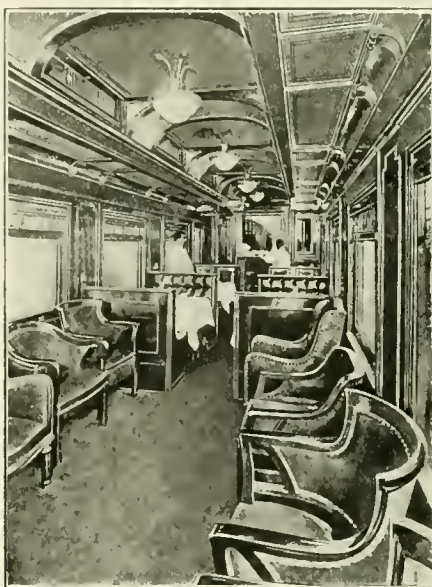

INTERIOR VIEW OF COACH ON THE CHICAGO GREAT WESTERN.

down after the darkness. It was like spring coming after a hard winter bringing flowers like jewels on her arms. The money was distributed along the line in the form of permanent improvements. The old track was greatly improved to the tune of \$11,000 per mile along the entire 1,500 miles. Steel bridges sprang into existence. Ninety pound steel rails took the place of the lighter worn out material. Wooden coaches gave way to new steel passenger cars. Steel freight cars came into service. High-powered modern locomotives, electric safety devices, telephone dispatching, and all the minor details of a first class railroad came suddenly in operation.

This was not all. Every village and hamlet along the rejuvenated road seemed to catch the vitalizing influence. Villages blossomed into towns, and towns into cities. The great travelling public, keen to appreciate good service, came clustering into the palatial cars. The service seemed to keep pace with the equipment. If the



NEW UNION STATION, ST. PAUL, MINN., UNDER CONSTRUCTION

and earnings were small, as is, or as was, the experience with all railroads. In the case of the Chicago Great Western the

unrecognized and now the change come. It need hardly be stated what the change was. It was not what is com-

men were not all new, there were new methods. The spiritual and intellectual tone of the road was lifted to a higher

plane of moral and physical activity. Regular meetings of officers and employees were held. The dumb became eloquent. The best thoughts of the brightest and best minds ran through the service like electricity. The lamp of hope and of courage was lit in the dark brow of industry, and the honest pride that comes from success well-earned shone in the eyes of the commonest laborer. Dispatch walked hand in hand with courtesy. There was unity of action, and harmony ran along the line pleasant as when the morning stars sang together.

All this was not done in a day, but it has been done, and there will be no turning back. The traveller from Chicago to St. Paul or Minneapolis, or to Omaha or Kansas City, has all the luxuries of the Orient in the stirring atmosphere of Western enterprise. All that science and art can do has been done, and will be maintained. The record of punctuality is unsurpassed. When the hand of the clock comes to the predetermined minute, the train is at the appointed place drawn by a fast-flying Pacific type of locomotive similar to the one shown on the opposite page. Reluctantly the delighted passenger leaves the silken softness of the upholstered car of which we furnish but a dim and diminished view. It is immaterial where the destination is, the artistic eye will be charmed to behold a station like the view shown of the new Union Station at St. Paul, now nearly finished, or something at least equally, if not more surpassingly artistic.

Space, or rather the lack of space, prevents us at present from descending on the mechanical appliances which keep this panorama of transportation in its never-ending cycle of ceaseless activity. Nearly all of the shops at the division points have felt the magic touch of transformation with the amazing unfolding of a transfiguration scene in a Christmas pantomime. Roundhouses that were little better than colossal huts are now concreted and smooth as monumental alabaster. Steam, compressed air and electricity run along the polished pits, and electric arcs after sunset hang their fringed tracery in fretted fire along the glittering roofs. In the machine shops the latest and best types of tools are in swift operation, ranging from the multi-spindled drill presses to the ponderous-jawed riveting machine that holds a locomotive boiler in its claws as a jackdaw holds a peanut. If there is any other 1,500 miles of railroad better equipped than the Chicago Great Western we would like to see it before we reach the terminal "where all the lamps are white!"

#### Women Engine Cleaners in England.

The vicissitudes of the war in Europe has called women into many occupations hitherto thought as being unsuitable for the gentler sex, and in none is their

work more appreciated than that of engine cleaners or wipers, as generally called in America. The accompanying illustration shows a group at work on an 8-coupled locomotive on the Great Central Railway of England. Their work is said to be quick and thorough, and if the reputation they have already earned is sustained it looks as if that branch of railroad work will be held by them. Their equipment in overalls is also said to detract in no way from their neat appearance. When the overalls are laid aside they are as neat and clean as saleswomen and much better paid, and consequently are well pleased with their occupation. It is a well known fact that British workmen generally pay little attention to their personal appearance, many of the works, even of the largest, having little or no provision for washing up, the workmen apparently preferring to do their cleaning up at home. The women are showing a

As trains pass in and out these little bulbs are constantly going on and off, but not without other and previous warning to the director. The man at the head of the whole system is called the director, and it is his duty to take the orders and instruct the two "levermen" what levers to pull when a train comes in or goes out. The signal and switch are thrown by one operation, which is a slight pull of the hand.

The machine used for operating the signals and switches has 224 levers. These give the director direct control of all signals and switches on the west end of the passenger station. There are 173 working functions for the switches and signals, one lever for a switch and one for a signal. The signals and switches operate electrically with the lever in tower. Indications of the correct operation of signal and switches received before the completion of the movement of

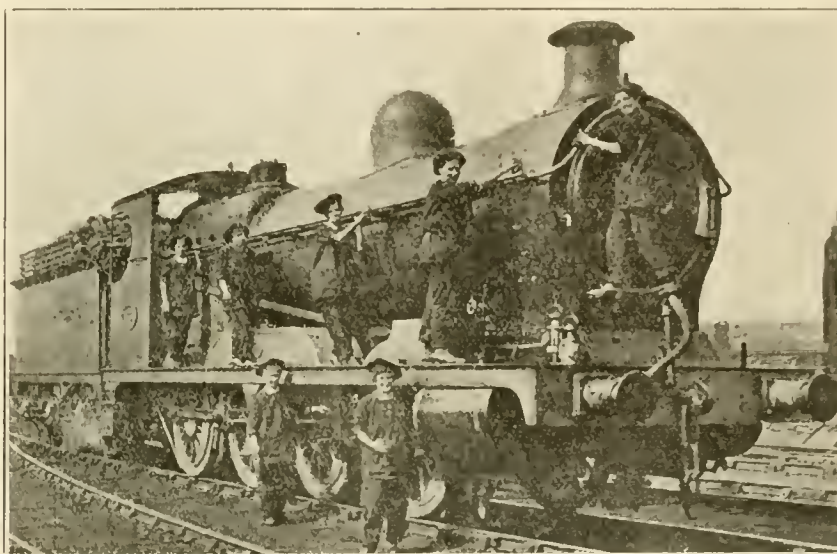

WOMEN ENGINE CLEANERS ATTIRED IN TROUSER OVERALLS, AT WORK ON ENGINE NO. 1134, GREAT CENTRAL RAILWAY OF ENGLAND.

step in the right direction, which cannot fail to have an effect on the future appearance of the workers in the less cleanly occupations, and the "black squad," so called, may, by the example of the young women called into certain occupations, become a thing of the past. Thus the terrible war may bring more reforms than are dreamt of in our philosophy.

#### New Signal System on the New York Central.

A new system of operating switches has been successfully established by the New York Central in Utica, N. Y. In the signal tower there is placed on the front wall a complete diagram of the tracks and switches on which trains enter the Utica yards, both freight and passenger. The tracks are of different colors, and on each a little electric bulb gleams out whenever a train comes in on that track.

the lever insure entire safety. The switch has got to move or the lever moving it cannot be disturbed at all. If the lever cannot be moved the director knows something is not working right. Thus a train cannot be moved until the signal is given, and the little bulb tells where the train is. The diagram also shows if there is something wrong.

#### Safety on the Pennsylvania.

Reports show that from January 1 to June 30 of this year, a total of 2,496,504 tests and observations were made on the Pennsylvania Railroad's Eastern lines to determine how well signals were being obeyed and the train operating rules followed. The results showed perfect performance in more than 99.9 per cent. of the cases. To be exact, in only one instance in each 1,224 trials was there any failure to follow implicitly the signal in-

dications or to obey the regulations governing train operation. These efficiency tests are conducted under the strictest rules. For instance, if an engineman runs his locomotive one foot past a "stop" signal, his action counts as a failure. In the period during which these tests were made, 76,700,000 passengers were carried on the lines east of Pittsburgh, and not a single one was killed in a train accident.

#### Annual Report of the American Locomotive Company.

The report for the year ending June 30, just issued by the American Locomotive Company, establishes a new high record in point of earning power. The net profits for the year of \$10,769,428, exceeds by 69 per cent. the best previous year of the company, which was that of 1906-7, when \$6,358,206 was earned. Next year may see a further increase as there are already \$19,376,532 unfilled orders for locomotives, as compared with about one-fourth of that amount on the same date last year. In regard to munition orders all on hand at the beginning of the last fiscal year have been completed and shipped. The report states that there was also charged against the profits for the year the entire cost of all new equipment purchased for use on munition work. In addition a sufficient amount was set aside to provide for the cost of eventually restoring the munition plants to the best condition for locomotive work when the occasion calls for a complete resumption of that class of work.

#### Car Shortage.

There has never been a time in America when a greater scarcity of cars has been experienced, especially in box-cars in the West and Southwest for movement of grain and high-class freight, and much complaint is heard because of the inability of shippers to secure cars to enable them to take advantage of the high prices for grains at all markets. A marked increase in business is shown west of the Missouri river, and the traffic in the East is also showing a large increase, the increase ranging from 8 to 22 per cent. over that of last year. Among the grain carrying roads into Chicago, the Illinois Central heads the list, having nearly 25 per cent. of the entire business.

#### "Safety First" on the Baltimore & Ohio.

Continuing its active work in the "Safety First" movement, and as its contribution to a campaign which the authorities of the State of Ohio will conduct to protect its citizens engaged in industrial employment against accidents, the Baltimore & Ohio Railroad system has notified Victor T. Noonan, director of safety

of the Ohio Industrial Commission, that it will tender the use of a passenger coach and will arrange for its transportation over the railroads operating in the State. The car will be fitted up with exhibits showing what the manufacturing and industrial concerns are doing to provide for the safety of their workmen. The Baltimore & Ohio, having been one of the pioneers in the "Safety First" movement, will show a series of transparency views on the windows of the cars, allowing the remaining space to be used as, in the opinion of the State officials, will best show the people of the State the progress that has been made in safeguarding wage-earners.

#### Change of Signals on the Pennsylvania.

A complete change in the color scheme of signal indications will be made on the entire Pennsylvania system as soon as the material can be obtained. White lights are to be eliminated altogether as a signal indication. Green will replace white for "clear" or "proceed," while a bright, distinctive yellow, visible at great distances, will be used for "caution." Red will continue to mean "stop." The elimination of white from the signal color scheme has been rendered desirable by the increasing use of white lights of various kinds in buildings, driveways, roads and streets close or adjacent to the railroad's right-of-way. Marker lights on the rear of passenger and freight trains; switch lamps and targets; markers for track tanks; "slow" signs; "resume speed" signs; hand lamps at interlocking and block signal stations; and lights displayed to the public at crossing gates. Lights for the latter purpose will be red instead of green, as at present.

#### Rail Accidents.

Investigation of rail accidents in this and foreign countries has shown that derailments in the United States are 26 times more numerous for each 1,000 miles of track than in Great Britain, three times as often as in Germany, but nearly as frequent in Austria. In trains of passengers the American and Austrian derailments are about the same, but the former are about 600 times the Great Britain record and 24 times that of Germany. In France one person out of 2,000,000 transported is injured, but in the United States the number is 14. Rail breakages are one in 2,000 in France, and the same number out of 1,350 in Germany, while in the United States it is the same out of 470.

#### Nicaraguan Railway Agreement.

Formal approval of the agreement between the Nicaraguan Government and the Pacific Railroad Company of Nicaragua has been given by both houses of

the Nicaraguan Congress and is promulgated by the President. Under the terms of this agreement the railroad company, which is financed in New York City, will construct and operate a railway from the Atlantic coast to the present Pacific railway system of Nicaragua or to the steamship lines owned by the same company. The total length of the new railway will be about 200 miles, and it will supply much needed transportation facilities from the Atlantic coast.

#### Improvements on the South Manchuria Railway.

Several improvements have been made by the South Manchuria Railway Company. Work was begun on the double tracking of the railway from Mukden south to Suchiatun, a distance of about 10 miles. This work is merely an extension, as the line from Dairen to Suchiatun, 236.5 miles, was double tracked several years previously. The construction of a railway bridge for the second track over the Hun River is in progress, and the structural steel therefor, as well as the rails for the whole section, are of American manufacture. A tunnel made of concrete under the tracks at Mukden station for facilitating the arrival and departure of passengers was constructed during the year.

#### Divisibility of Gold.

Few people realize how thin gold can be spread. In the manufacture of gilt wire used for embroidery, the amount of gold employed to cover one foot of wire does not exceed the 720,000th part of an ounce. Those fond of figuring know that if the 720,000th part of an ounce is used in covering one foot of wire, that in an inch there is only the 8,640,000th part of an ounce. We may divide this into 100 parts and yet see the gold quite distinctly with the naked eye, and that the exceedingly minute particle possesses all the characteristics of a large piece.

We are constantly hearing of schemes for using cheaper material than gold leaf for the decoration of railway cars, but the people who scheme such changes do not analyze the cost of the gold leaf.

#### Additional Improvements on the New York, New Haven & Hartford.

The New York, New Haven & Hartford will shortly construct a new roundhouse, shop and office building at the White street yard, Danbury, Conn. The roundhouse will contain eight 95-ft. stalls, the shop will be 48 ft. by 100 ft., and the office building of two stories will be 42 ft. 6 ins. wide, by 49 ft. 8 ins. long. The improvements will cost about \$65,000.



## "The Thomas Transmission" Rail Motor Car

There has just been completed at the Government Railway Workshops, Petone, New Zealand, a rail motor coach possessing many striking features. The complete vehicle with the exception of the body was supplied by the Thomas Transmission, Limited, of London, and the system of transmission is known as "The Thomas Transmission."

The main power unit consists of an eight-cylinder petrol engine of the "V" type, in two sets of four cylinders each having a bore of 7 ins. with a stroke of 8 ins. Opposite cylinders act on the same crank. One cylinder of each pair has a forked connecting rod with bearings on the outside of the brasses of the rod of the opposite cylinder. By this means the length of the engine is kept within reasonable limits. The valves are located on the outsides of the cylinder castings for accessibility. One Claudel-Hobson carbureter is fixed to each end of a common induction pipe, and the inlet and exhaust pipes are placed on the outsides of the cylinders. The silencers, one for each set of cylinders, are located on opposite sides of the engine. Dual ignition and separate magnetos for each set of cylinders are provided. The engine is reversible and the rotation of the camshaft, which is fitted with small flywheels to minimize backlash, is always in the one direction, irrespective of the crankshaft rotation. This insures that the oil and water pumps as well as the magnetos only rotate one way. Water cooling radiators are fitted at each end of the car, side ducts allowing a free current of air, in whatever direction the car may be running. Oil cooling radiators are provided: one for cooling the lubricating oil for the engine, and one for the oil which lubricates the planetary or epicyclic gearing. The "Thomas" electro-mechanical transmission consists of two electrical machines (each of about one-third normal horsepower of the petrol engine) and a planetary gear. The engine is located in the middle of the car having the planetary gear, and the first electrical machine at one end of the engine and the second electrical machine at the other end. The first electrical machine in conjunction with the planetary gearing and two magnetic clutches form a rigid unit. The engine drives the casing of the planetary gearing and the latter splits the drive into two paths—one driven shaft providing a mechanical drive to the outside axle of one bogie and the second driven shaft (which is hollow) drives back to the first electrical machine referred to.

Current is transmitted from this first electrical machine to the second electrical machine at the opposite end of

the engine to which it is not connected mechanically. This second machine provides an electrical drive to the outside axle of the second bogie. A main controller which provides twelve speeds operates the car. By reversing the di-

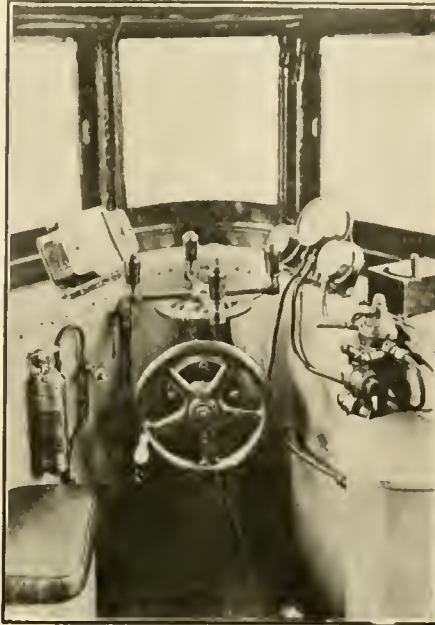

VIEW OF DRIVER'S COMPARTMENT.

rection of rotation of the engine the same speeds in the opposite direction are secured for continuous running. To start the car the control handle is placed in "start engine" position which con-

nects the car battery across No. 1 electrical machine. By closing an auxiliary switch the No. 1 machine is coupled to the engine, thus starting it. Once the engine is working, the auxiliary switch is moved to the "off" position and main controller placed in the first speed notch. By slowly operating auxiliary switch to "on" position, the free wheeling clutch is gradually engaged, causing No. 1 machine to rotate in the reverse direction to the engine and produce a mechanical drive to one bogie and by the transmission of the current to the second machine an electrical drive to the other bogie. As the car gains in speed the main controller handle is gradually moved to "top speed" position, when the direct drive from engine to running wheels is obtained by the engagement of the top speed clutch which locks the planetary gearing solid, and also reduces the current generated to zero. By moving the controller handle to a position beyond "top speed," the battery used for starting the engine (but not for propelling the car) may be recharged. The car can be driven from either end at will.

Westinghouse brake equipment is provided; the car is lighted with electric light and carries an electric headlight at each end. Hand brakes are fitted, as well as air sanding apparatus. The above arrangement is ideal for a petrol-electric rail coach, as a direct mechanical drive on top speed is obtained, as well as the flexibility of a purely electrical drive. The total weight of the car is 36 tons, about 9 tons of which comprise the weight of the engine, transmission gear, radiators and electrical machines. The car is capable of hauling a 15-ton trailer up a grade of



"THOMAS TRANSMISSION" RAIL MOTOR CAR

nects the car battery across No. 1 electrical machine. By closing an auxiliary switch the No. 1 machine is coupled to the engine, thus starting it. Once the engine is working, the auxiliary switch is moved to the "off" position and main controller placed in the first speed notch. By slowly operating

1 in 40 at 15 miles per hour, the gross load being over 50 tons. The maximum speed on the flat is over 40 miles per hour. The gauge is 3 ft. 6 ins.

Any further information will be supplied on application to The Thomas Transmission, Limited, 14 Leonard Place, Kensington, London, W., England.

# Test of Locomotives

By MR. D. R. MacBAIN, Superintendent Motive Power, New York Central Railroad

Continuing his observations on the various tests applied to locomotive boilers and the results obtained therefrom, and of which the first instalment was published in the August issue of RAILWAY AND LOCOMOTIVE ENGINEERING, Mr. MacBain proceeded to state that: "In order to get away from these strains that were referred to in the first place, and which were cracking the side and tube sheets vertically, and the back, head and throat sheet as well, we anticipated that a limited amount of slack under the staybolts, when they were first applied, would probably compensate for the movements due to expansion and contraction and eliminate some of the strain off the sheets and bolts. The result of our consideration was that we made up a brief but comprehensive schedule of instructions, and among other details we embodied the experiment that the vertical front and back rows from the mud ring were to be set

and, furthermore, that the elimination of the excessive staybolt breakage will result in a remedy for the leaky side-sheet seams.

"It may be stated that when these locomotives originally came into service they all had rigid staybolts, and it was quite a common experience to find anywhere from three to five or more bolts broken in these three rows. We made an investigation, as shown in Fig. 11, the procedure being as follows:

"We happened to have one of this type of engine in the shop for general repairs, at which time Mr. Linderman, at that time supervisor of boilers, at West Albany, personally had charge of the operations. He began by constructing a heavy templet, as shown in Fig. 11, reaching from the center at the top of the outer boiler sheet down to a point at the side as shown, and clamped it at the center to the boiler. This was done when

off, the templet refitted, and a pressure of 225 pounds of cold water put on, and under this test the templet retained its seat, so that it proved pretty conclusively that the distortion of the boiler was due to temperature and not to pressure.

"The application of three rows of flexible staybolts, as referred to, with 1/32, 1/16, and 1/32-in. slack, respectively, removed the cause of the trouble and stopped the breakage. We had no further trouble along that line. It also had the effect of taking the stress off the half side sheet seams. The vertical stress that there was on those half side sheet seam rivets was what prevented them from leaking, and made it impossible for us to keep them tight with the ordinary repairing process of hammer and tools.

"Furthermore, to ascertain, if possible, why the back flue sheet, and the front flue sheet also, for that matter, became deflected or distorted, about six years ago the New York Central, at the West Albany shop, installed an experimental set of flues in one of the company's large Pacific type of locomotives, as shown in Fig. 12, with a view of determining whether or not certain theories we had assumed were correct. The idea was that while the locomotive was working and the fire hot, with the circulation in good order, the expansion in the boiler proper, that is, between the flue sheets, was greater than in the flues. The results of this test were somewhat remarkable, as will be shown as we proceed.

"Mr. Linderman, supervisor of boilers at that time, personally superintended the operation, and each flue, before it was placed in position at each end, had it depressed 1 5/16-in., Mr. Linderman personally doing the depressing of the flue, and, at a signal from him the man at each end stuck the flue in the sheet and immediately had it expanded. The complete set of 382 flues was applied in this way, and as a result the entire set of flues had a sag or bend of over one inch more than the normal when the operation was completed.

"It will be observed by referring to Fig. 12, that a needle was attached to one of the top flues at the center and extended up through the shell of the boiler, and was attached to a recording device to show what amount of movement, if any, took place under the various conditions of service from the time that the fire was started in the firebox until the completion of a trip on the road. Fig. 13 shows the movement of the tube, to which the needle was attached from the time that the fire was started until a pressure of 200 pounds of steam was raised. It will be noted that almost immediately after the fire was started



FIG. 9.

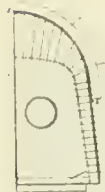

FIG. 11.



FIG. 10.

1/16-in. loose, and the same allowance was also made in the case of the outer row around the back head.

"Figure 9 shows three rows of bolts, as indicated by "X," immediately above the last row of short or horizontal bolts, in several wide firebox boilers where a breakage of bolts had occurred too frequently. We made a careful investigation of this feature with the result that a number of experiments were made to determine the cause thereof. These were carried out carefully, and the results of which were very satisfactory, and will be dealt with more fully as we proceed in the further progress of our observations.

"Briefly, the result of these experiments was that it is our belief that the same agency that is responsible for the excessive breakage of staybolts, as shown in Fig. 9, is responsible also for the leaky side-sheet seams, as shown in Fig. 10,

the boiler was cold. The job was very carefully done, being scraped to a fine fit. A skilled mechanic worked nearly a week before he got the templet to suit him, and then after it was properly fitted, the engine was fired up, and the effect of the firing up, on account of the heating of the boiler, was that when there was 200 pounds of steam pressure on the boiler the templet lifted at both ends 3/32-in. That was a difficult thing to explain, but we could not get away from the evidence very well, and it threw a great deal of light on the breaking of the three rows of bolts referred to in Fig. 9.

"It was suggested to us during the time that the experiments were being made, that probably the distortion, or the raising of the templet, was due to pressure rather than to temperature, so in order to find out definitely whether that was the case or not, the engine was cooled

the needle began to pull downwards fully  $\frac{1}{8}$ -in., and remained practically stationary for a few moments, then began to rise, as shown, and continued in that direction until about  $\frac{1}{8}$ -in. above the normal position, at which point the steam pressure began to rise, and the raising of the needle from that point up to 175 pounds pressure was gradual, but very rapid from 175 to 200 pounds, with the result that the total rising of the needle

after the throttle was closed and while the locomotive was drifting. The maximum downward pull on the needle was  $\frac{3}{16}$ -in., this point having been reached while the engine was being worked hard and running at high speed.

"Fig. 15 shows a record of the second road test, which was made from Utica to Palatine Bridge. We cannot explain the rising of the needle  $\frac{1}{16}$ -in. above the normal line at the start of this trip,

and as much as the firebox sheets. Certain it is that these mysterious varieties in expansion is the cause of much of the trouble that has arisen in boiler maintenance and it is gratifying to know that in the light of such experiments as have been made under Mr. MacBain's supervision, much real progress towards a more thorough understanding of the causes of fracture in some of the parts has been made. This, of course, will lead to new

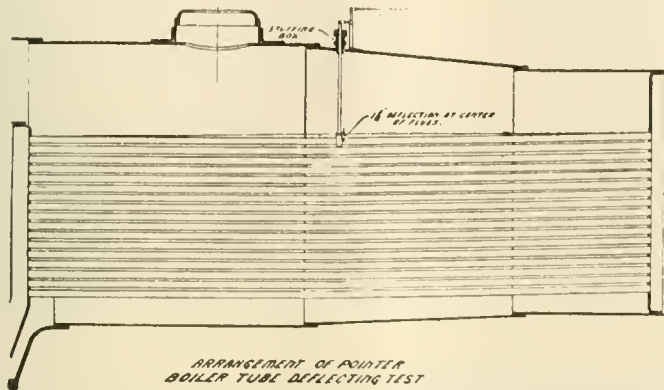

FIG. 12.

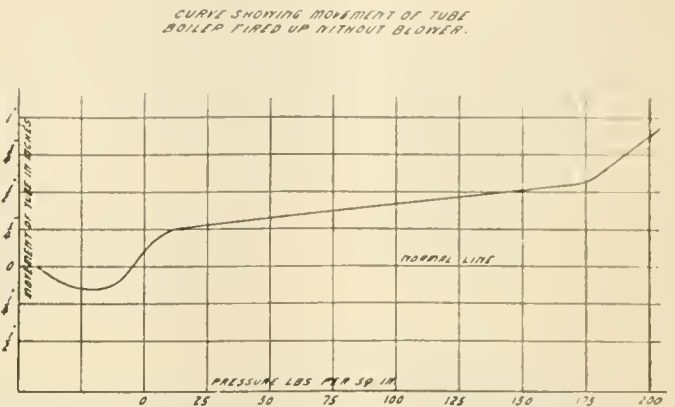

FIG. 13.

above the normal line was  $\frac{15}{16}$ -in. It is difficult to account for the rapid rising of the needle between the time that the pressure increased from 175 to 200 pounds, unless it be that the needle did not work in the stuffing box quite as freely as it should have done, but we cannot see how that could have been, as the packing in the stuffing box around the needle was very loose.

"Arrangements were then made to make a road test, and the operation was

but it will be noted that it did not occur again during the entire trip. The remainder of the record is nearly a repetition of what occurred on the first trip, the increase in the downward pull of the needle, in our opinion, being due to the engineer who was running the engine on this trip working the engine harder than the engineer did who handled the engine on the first test, the maximum increase in pull downward on the needle being  $\frac{5}{16}$ -in. The breaks in the card indicate

forms and new methods, and in this regard much real progress has been already made, and since the general introduction of the use of superheated steam, a general lowering of the boiler pressure has been made possible which has been an important factor in the conservation of boilers. Since the introduction of various new welding processes also repairs are comparatively easy of performance, and altogether there is a marked improvement in point of economy in the maintenance

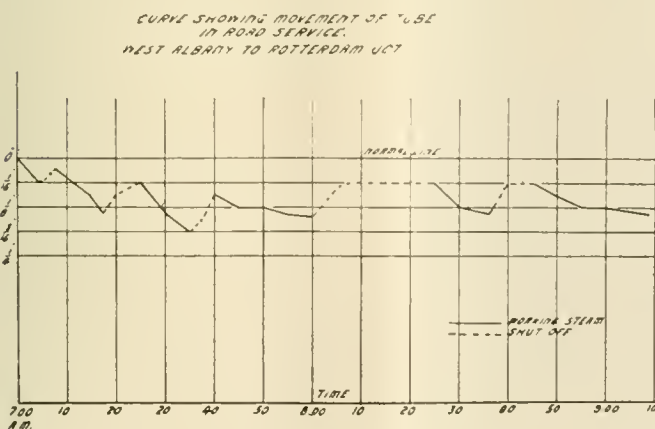

FIG. 14.

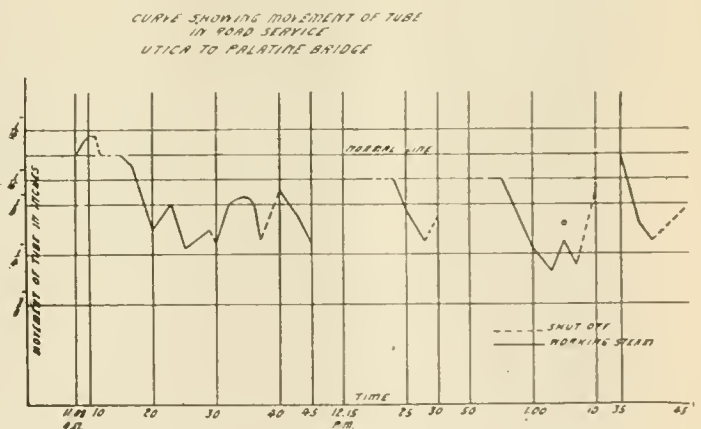

FIG. 15.

conducted by Mr. Linderman and Mr. McPartland, the latter an engineer of long experience in testing locomotives and their appliances. Fig. 14 shows the record made by the recording device on the first road trip, which was run from West Albany to Rotterdam Junction.

"It will be noted that immediately upon starting out the needle began to pull downwards, as shown by the solid lines, the dotted lines being the record made

the periods during which the apparatus was cut out while switching was being done, and the line at the right of the card, which shows the needle raised to the normal line, followed quite a long stop at a station."

It will be observed that in the parts of Mr. MacBain's article already published several old theories are already exploded. It was generally accepted that the outside sheets of a boiler did not ex-

of the boiler of the modern high-powered locomotive. This will undoubtedly go on until a still greater degree of reliability is attained, and as investigations such as these indicate the requirements.

The next article illustrating this series of experiments will refer to an installation of flexible staybolts in another Pacific type of locomotive, and will appear in the October issue of RAILWAY AND LOCOMOTIVE ENGINEERING.

# Advantages of the Empty and Load Brake

By WALTER V. TURNER, Assistant Manager, Westinghouse Air Brake Co.

The 'empty and load brake' is one wherein a braking force is used varying directly with the weight of the car and thereby giving a constant braking ratio for all conditions of car loading or a ratio much more limited in its variation than in the case of the empty car.

The passenger empty and load brake as used on the New York Subway provides a constant braking ratio irrespective of the condition of car loading, but the apparatus necessary to attain this very desirable operation is of a nature not adapted to freight service at the present stage of the air brake art—or better said, at the present stage of steam railroad requirements—which are different ways of saying the same thing.

The empty and load brakes as designed for freight service has two distinct braking forces due to the operation of one or two brake cylinders during brake applications. The full service braking force obtained with the one cylinder is 60 per cent. of the empty weight of the car, as with the empty car brake. It is used with the empty and partially loaded car, but when the car is loaded beyond a certain point the second brake cylinder is cut into action to assist the first. The total braking force now equals 40 per cent. of the weight of the fully loaded car instead of from 15 to 17 per cent. with the single capacity brake. The reason 60 per cent. braking ratio is not used for the loaded car is that if it were the second cylinder could not be cut in until the car was fully loaded without exceeding the 60 per cent. braking ratio. With a 40 per cent. braking ratio for the fully loaded car, the load brake can be cut in when the car is little more than half loaded (50 to 55 per cent. loaded, according as the ratio of loaded to empty car weight ranges from 3 to 4) without exceeding a braking ratio of 60 per cent. for that particular condition of loading; that is, as cars do not average a full load at all times, this load braking ratio of 40 per cent. will more nearly average 60 per cent. in the usual conditions of service, and braking will be more nearly uniform throughout the average train than it would be possible to have with any other similar arrangement.

The diagram shows the way the braking ratio ranges for different conditions of car loading, with and without the empty and load brake. Starting with 60 per cent. braking ratio for the empty car (i. e., 0 per cent. loading) the ratio drops more rapidly at first with the initial loading than it does as the car approaches a fully loaded state (100 per cent. loading).

This is because a certain addition in load is proportionally smaller, the heav-

ier the car is, at the time the addition is made.

Starting with 60 per cent. braking ratio for the empty car, the braking ratio for the fully loaded car drops to 15 per cent. where the loaded weight is four times the empty weight of the car, as in the case of the new 180,000 lb. capacity hopper cars for the Pennsylvania R.R. weighing 60,000 lbs. empty. And the braking ratio drops to 17.1 per cent. where the ratio between loaded and empty weights is 3.5 to 1, as with the 40,000 lb. car of 100,000 capacity.

As an instance of the increased severity of operating conditions on our railroads, note the change in this ratio between empty and loaded weight. It is but a short time since the latest word in the freight car was one weighing 40,000 lbs.

the braking ratio runs up to 64 per cent. only when the load is cut in at 50 per cent. loading and the weight ratio is 4 to 1, and to 62.2 per cent. when the weight ratio is 3.5 to 1. As 50 per cent. loading is a round figure of most convenient use, it should be used as the point of car loading for cutting in the load brake. Due caution should be exercised to see that the load brake is not cut in at a point of loading less than this in order to avoid a braking ratio undesirably greater than 60 per cent.

A line representing a 4 to 1 weight is shown starting from a 40 per cent. braking ratio for the empty car and drops to 10 per cent. for the loaded car. Where the car is either empty or fully loaded at all times; i. e., having no operation with a partial load and employs the empty

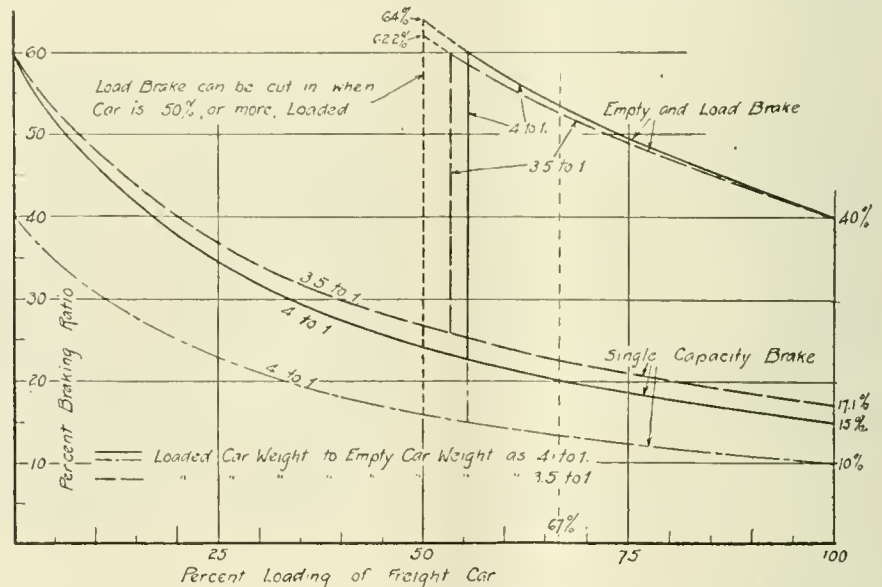

CHART SHOWING BRAKING RATIOS FOR VARIOUS CONDITIONS OF FREIGHT CAR LOADING WITH AND WITHOUT EMPTY AND LOAD BRAKE.

empty and 120,000 lbs. loaded; that is, having an 80,000 lb. capacity. Here the ratio is 3 to 1. But now a ratio of 3.5 to 1 is most ordinary and, as pointed out, 4 to 1 is coming into vogue, with a case of 4.25 to 1 on the Bingham and Garfield Railroad where this ratio comes about due to overloading of ore cars. The increase in this ratio only means a greater contrast between empty and loaded car braking ratios, and this in turn less uniformity of retardation, with resultant slight action and less safety of control on mountain grades.

If, however, the empty and load brake is installed, it may be cut into load operation with 55.5 per cent. loading without exceeding a 60 per cent. braking ratio where the weight ratio is 4 to 1, or less, and the corresponding point for a 3.5 to 1 ratio is 53.4 per cent. loading. However,

and load brake, this 40 per cent. empty braking ratio is most desirable.

The lower braking ratio for freight service is especially desirable also from another point of view besides the one of having empty and loaded cars braked uniformly when the same cylinder pressure obtains on each. This is for the reason that the lower braking ratio minimizes the effect of serial action in the pneumatic application of brakes on a long train. For a certain manipulation of the brake valve the cylinder pressure on the head end and the rear of the train as the brake application progresses will be the same irrespective of the braking ratio, and the difference in cylinder pressure between the head and rear ends will also be the same, but this difference in pressure results in a difference in retardation between the two ends of the train greater in the same

proportion as the braking ratio is higher. Therefore, all other things being the same, a condition of slack action in a train due to serial application of brakes is twice as bad where the braking ratio is uniformly 80 per cent. as it is when the ratio is 40 per cent. throughout.

It is recommended that the empty and load brake be so installed that 40 per cent. braking ratio will be obtained when the car is fully loaded. It is evident that it could be designed and installed to greatly exceed this, but 40 per cent. braking ratio will not only control a train on any railroad grade in this country, but will bring it to a standstill on a grade of 4 per cent. from a speed of fifteen miles per hour in 575 feet, while with the single capacity brake this train could never be stopped,

but would actually run away. It may be asked if a 40 per cent. braking ratio is enough to control a car, why 60 per cent. is maintained for the empty car since the above is an assertion that it is not necessary. The reason for this is that cars may be equipped with the empty and load brake and passed to roads which do not have empty and load brakes and which, therefore, are not expected to cut the brake into load position, therefore the car, even though loaded, would be operating as though it were equipped only with a single capacity brake, in which case it is advisable that the braking ratio be that which would develop from the single capacity brake, namely 60 per cent. empty and 15 per cent. loaded. Now, if the braking ratio for this empty car was

40 per cent. and with the car loaded but with the brakes being operated in empty position, the braking ratio would be only 10 per cent. On roads where the brake is used in load position when the car is loaded, and when cars remain on their own road, as for example, the Bingham and Garfield Road, the braking ratio for the empty car should be 40 per cent. and not 60 per cent., and particularly should this be so where the cars are handled either fully loaded or empty as before mentioned.

Nearly everyone who reads these pages is acquainted with the results of undesired slack action in long freight trains arising from lack of uniform retardation, and in a future article this will be touched upon at a greater length.

## Why the Crews Like the Electric Locomotive on the Norfolk & Western Railroad

By H. W. THOMSON, Norfolk, Virginia

Not long ago a steam railroad man visited the electrified division of the Norfolk & Western Railroad which has been in operation about a year. He was welcomed by the division staff and, as naturally the new motive power was the chief topic of conversation, he received a full account of the performance of the Westinghouse electric engines—how they were hauling greater tonnage than the old steam mallets, making better time, requiring less time for repairs, and distinguishing themselves generally.

"All this is very interesting," was his comment, "but what I want to know especially is what the men think about the electric engines. I don't care how perfect they may be mechanically, I shall not be a convert to their use unless I find the men who actually run them are strongly in favor of them. And with your permission," he continued, "I'm going to look into this side of the question myself." So he went out into the roundhouse, mixed with the men, and was invited to make a trip in the cab.

The first thing, as he discovered, that won the favor of the men to the new engines, was the announcement that the old steam force was to run them. It is natural that they should assume when they first heard the line was to be electrified, that many would lose their jobs in favor of electrical experts. But, as a matter of fact, every electrified railroad has trained its own men to the new work with entirely satisfactory results.

"How do you like these engines?" the visitor asked the engineer of the one he was riding on. "Do you prefer them to the mallets?"

"I have been running steam locomotives for over twenty-five years," was the reply, "and now I am through with them. Only the other day I had a chance

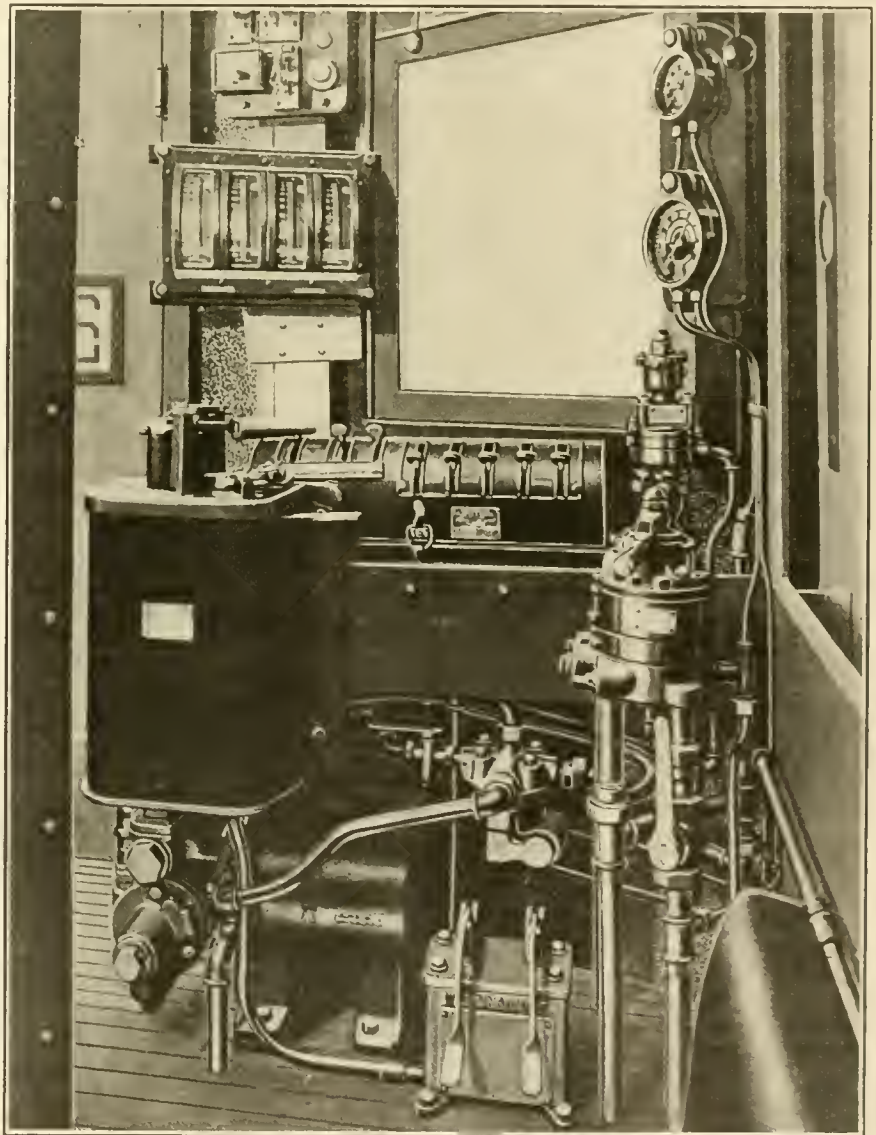

VIEW OF INTERIOR OF CAB OF ELECTRIC LOCOMOTIVE OF THE NORFOLK & WESTERN RAILROAD.

to get a passenger run and turned it down. I won't take one of those runs until they put electrics on them."

While men in all walks of life are inclined at times to regard their lot as a hard one, it is probable that this engineer during his steam service never considered the cab of a steam locomotive a particularly comfortable place to work in. But a little experience with far pleasanter conditions in an electric engine opened his eyes to many things he had taken as a matter of course before and made him an ardent enthusiast of this latest step in railroading.

The superiority of the electric over the steam locomotive from the crew's point of view is evident in almost every detail of the day's run. Before taking a steam locomotive out, the engineer has to give it a thorough inspection, as he is responsible for its operating condition. With a steam locomotive there is a multitude of details that require attention—bearings, oil cups, clearances, nuts, valves, injectors, boiler appliances, and a hundred more. Everything has to be gone over with care, and frequently much hard work has to be done before it is safe to start. The mechanism of the electric engine is in comparison quite simple and a few minutes suffice to examine every part.

Stepping into the cab of the electric engine, he finds it warm in winter, cool and well ventilated in summer, and perfectly protected from the weather. His steam locomotive cab was intensely hot in summer, and hot, cold and damp by turns in winter, while if he ran reversed against the wind, in winter it was al-

most intolerably cold. At his station on the electric engine he is at the very front of the train with no boiler, smoke or steam to interfere with his view. He is not compelled to put his head out of the window into a possible 100-mile an hour gale nor is he treated to a deluge of cinders and gases.

On starting he finds another of his many troubles has disappeared, for a movement of a lever suffices. The superior tractive qualities of the electric engine, with its grouped independent trucks giving a higher drawbar pull per pound weight on the drivers, eliminate much wheel slipping, slacking down, and taking fresh starts. While running, light levers, which require practically no physical effort to operate, gives him complete control over the train. Neither he nor his fireman are under any strain or responsibility as to the supply of power; it is provided for them in unlimited amounts. Meters give exact information as to what each truck is doing and he is no longer compelled to rely mainly on his ears and bodily sensations for his knowledge as to the conditions of the mechanism under his control.

He no longer looks forward to tunnels with dread. "With steam operation," said the engineer, "it took us twenty, and frequently more, minutes to crawl through the Elkhorn Tunnel and we came out usually half dead with suffocation, but now we go through in two and a half minutes with pure air all the time."

On the Norfolk & Western an advantage of certain types of electrical equipment is especially marked; namely,

the use of automatic regenerative braking for controlling the speed of the train when descending a grade. This consists, briefly, in the motors acting as dynamos when turned by the force of the descending train, whereby they regenerate and return power to the line. The power regenerated and returned to the line when the motors are used in this way acts as a most effective brake. The speed of the descending train, when regenerating, is automatically controlled just as it is when the motors are being operated by the current when ascending a grade. "We used to drop down hill with our brakes in the old steam days," said the engineer, "and it was nip and tuck for air compressors to hold up the air. Getting down the mountain used to consist in applying the brakes, releasing them to charge the train line, and applying again. Quite frequently we would all but run away before we were down and there wasn't a man of us that didn't breathe a sigh of relief every time he got his train to the bottom. Now we drop down by regeneration and always have the train line fully charged so that we have plenty of air to make a quick emergency stop at any time."

The engineer's main business is to run his train safely and to maintain schedules, and the less he has to interfere with this work the better. It is evident that the electric engine by reducing the number of details requiring the engineer's attention and increasing his physical comfort, tends to increase his efficiency, thereby benefiting himself, his road, and his passengers. For these reasons the crews prefer the electric locomotive.

## History of a Down East Old Timer

By A. H. CHICK, Waltham, Mass.

Articles contributed by the readers of RAILWAY AND LOCOMOTIVE ENGINEERING that appeared almost monthly in the years past, and were accompanied with illustrations of old locomotives, were of absorbing interest to many readers. Those that appeared in the years 1909 and 1910 brought back visions of early days to the old railroaders, and to many not so old, whose younger days were filled with balloon stacks coughing black smoke fading into vapory rings of translucent amethyst towards the clouds.

More recently, technical matters receive growing attention, and while this is as it should be, and of great value to all engaged in the mechanical department of railways, still there are many readers to whom the historic side of railroading appeals stronger and stronger as the years pass on. Hence it is with the hope of reviving occasional articles similar to those referred to that I enclose a photograph of a locomotive of the vintage of 1872. It is one of the Boston & Maine

locomotives, No. 58, and named "Wm. Merritt," and built at the Manchester Locomotive Works. It is what was

engines built in 1872 and 1873. They were intended to compete with what was known as the Eastern railroad, now a

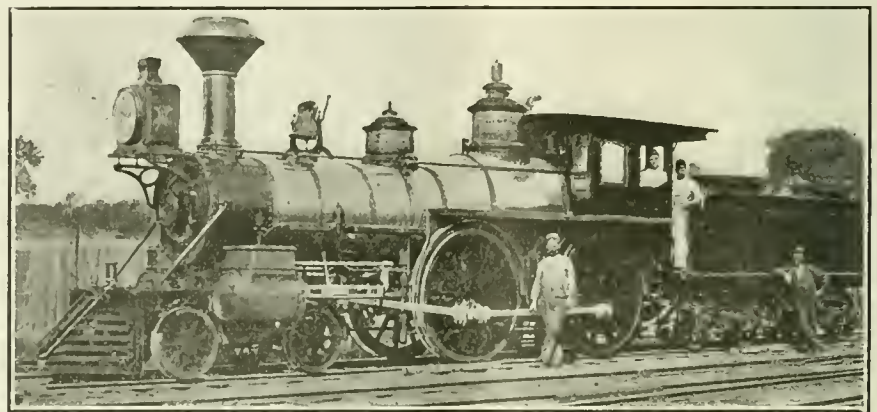

LOCOMOTIVE NO. 58, BOSTON & MAINE RAILROAD.

known as the Blood type of locomotives with cylinders measuring 17 x 22 inches.

The Boston & Maine had ten of these

part of the Boston & Maine, on their through trains from Boston to Portland, Me., the two roads running parallel to

each other, and the rivalry for passenger traffic being very keen. The roads were not to be compared to what they are now, but the speed was very great, as fast, in fact, as one cared to ride over the rough roads of that period.

This particular engine was named after Mr. William Merritt, the superintendent of the Boston & Maine at the time the engine was built. The photograph is from a collection belonging to Mr. Charles E. Merritt, a son of the elder Mr. Merritt, who, at the present time is attached to the staff of the Boston Freight Terminal of the same road and who has been in the service continuously since 1863, and who joins me in the hope of seeing an occasional "old timer," and a revival of a very interesting feature in your popular paper.

#### Pneumatic Pipe Vise.

BY E. L. BOWEN, AIR BRAKE FOREMAN,  
ILLINOIS CENTRAL RAILROAD.

The accompanying sketch shows a shop made pneumatic vise. Its chief merits are its quickness of action and reliability.

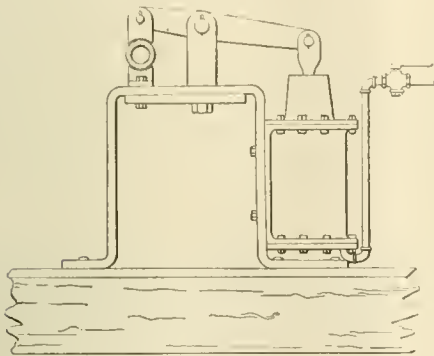

PNEUMATIC PIPE VISE.

It is especially serviceable in pipe bending. When the pipe is heated the clamp can be closed on the pipe instantly and the operation of bending begun before the pipe loses any appreciable degree of heat. An 8-inch air brake cylinder is securely held by  $\frac{5}{8}$ -inch tap bolts to a brace made of flat iron 1 inch by 8 inches. On the upper portion of the brace or frame a fulcrum is attached, which is forked to receive a movable lever made of soft steel. A piston with attached rod operates the lever, the shorter end of the lever being equipped with a forked attachment having teeth cut in its lower face immediately under which is a block of soft steel bolted to the frame and also similarly toothed. The frame is securely bolted to a suitable block of wood. The general dimensions may be made to suit. In the device in operation here the lever is 3 inches in width in the center tapering to  $2\frac{1}{2}$  inches at the ends by  $1\frac{1}{2}$  inches in thickness. The fulcrum is 3 inches in width by  $3\frac{1}{2}$  inches in thickness. A  $\frac{1}{2}$  inch cut out cock, drilled three ways, with attached lever, controls

the air admission. It should be noted that the toothed clamps should be tempered to insure durability in service. The coupling pins are 1 inch in diameter, also of soft steel. The fulcrum bolt passing through the reinforced brace as shown is  $1\frac{1}{4}$  inches in diameter. There is little finishing necessary with the exception of the coupled ends and piston rod. The distance from the block of wood to the inner edge of the upper part of the brace is 26 inches, and the width between the inner edges of the brace 16 inches. It is easily and economically constructed and will last till doomsday.

#### A Power Test on a Turn Table.

By A. J. DRURY, Cincinnati, Ohio.

A railroad company was building a turn table and an inquiry came to me as to the amount of power necessary to operate one. I accordingly made a test on a table, with good results.

The turn table tested was located in the yards of the Louisville and Nashville Railroad, at Covington, Ky. It was 75 feet in length, and of the common type; namely, with flanged wheels rolling on a circular "T" rail track, the outside diameter of the circle of track being about 67 feet.

The turn table was operated by a 15 horsepower, three phase, 60 cycle, 220 volts, 1,100 R. P. M. slip ring, type B. H. Fairbanks Morse motor, with external resistance, and a drum controller. Two tests were made, the first with the table running light, and the second with a 376,000-pound locomotive and tender of overall length of 65 feet on the table. The test consisted of taking the highest reading of the three phase wattmeter as the controller handle was moved from point to point when the turn table was being accelerated, and at intervals of two seconds after full speed was attained. The regular operator handled the controller and it was fully explained to him that it was necessary that he make the turns as was his habit. That we were not checking him up in any way, but that the information was wanted for another turn table about to be built.

The time required to make one complete turn when the table was running light was 55 seconds; when loaded 65. The test was made in both cases starting from a standstill, and shutting off the power instantly after a complete turn had been made. Integrating the curves showed that the power consumed per turn when the table was running light was about  $1/10$  kilowatt hour, when loaded  $18/100$  kilowatt hours. The power consumption being negligible, in the case of a company generating its own power the only consideration is to have a motor of sufficient size, but when power is purchased, the central station generally has a minimum charge, usually of about one dol-

lar per month per horsepower of motors, and in that case too large a motor would incur paying out money for which nothing is received, as it would be almost inconceivable of a turn table operating sufficient times per month to consume the amount of power represented by the minimum charge.

#### Repairing Diaphragm Portion of Air Pump Governors.

By F. W. BENTLEY, JR., MISSOURI VALLEY,  
IOWA.

A common defect of the diaphragm portion of air pump governors is the shortening of the No. 47 diaphragm valves, both through wear on the point of the valve and on the seat in the body. However due to the conical shape of the end of the valve, it suffers the most, being frequently found so shortened that the thin brass diaphragms are severely stretched by the regulating spring before the valve can make a perfectly air tight seat. Though a governor can and frequently does perform its work in spite of the above, it is many times not attended to until the governor is in not as good

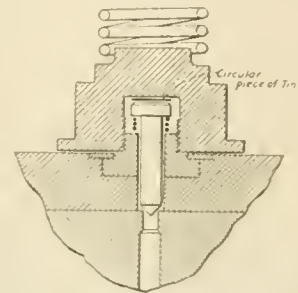

REPAIR ON AIR PUMP GOVERNOR.

operating condition as it might be for perfect service.

At points or roundhouses where a new valve can be applied and ground in, the governor is easily repaired, but at many places where parts of this kind cannot be kept in stock, the defect sometimes causes a great deal of trouble until renewed parts can be secured.

The sketch shows a simple emergency "kink" which the writer has used very frequently with good results. A small circular piece of thin tin or old diaphragm is cut and dropped between the end of the valve and the bottom of the diaphragm holder. This throws the valve point further down, which then touching the seat allows a perfect freedom of the diaphragms to move up and down after the ring and spring box have been applied, tightened down, and the regulating spring set to required main reservoir pressure. The insertion of the slip of tin or sheet brass in no way affects the diaphragm valve spring as these are frequently found dead and in need of resetting. On hurried roundhouse repair this little "kink" will be found an excellent remedy for aggravating governor troubles.

### First Three-Position Signal for England.

BY R. W. A. SALTER, LONDON, ENGLAND.

As the result of a recently paid visit to this country, the officers of the signaling and traffic department of the Great Western Railroad Company, of England, were so favorably impressed with the three-position signals employed here that they have endeavored to obtain an experience of their actual merits by installing one on their own system. It has been located on the westbound mainline just outside Paddington Station—the London terminal of the Great Western line.

The signal mechanism has been designed in America by the Union Switch and Signal Co., of Swissvale, Pa., and supplied in conjunction with the McKenzie, Holland and Westinghouse Co., of London, who must be regarded as the pioneers in this branch of signaling in England.

When in a horizontal position the arm of the signal displays a red light, indicating "stop." In the second position—an angle of 45 degrees—it exhibits a yellow light, signifying "proceed with caution, prepared to stop at next signal." The third position, exhibiting a green light, indicates to the engineer that he may "proceed, and the signals at the next box are safe."

The mechanism is erected on a tubular iron post with a concrete base—Union style T-2—designed for 10-volt direct current operation. The operating mechanism consists of a 4-pole electric motor driving

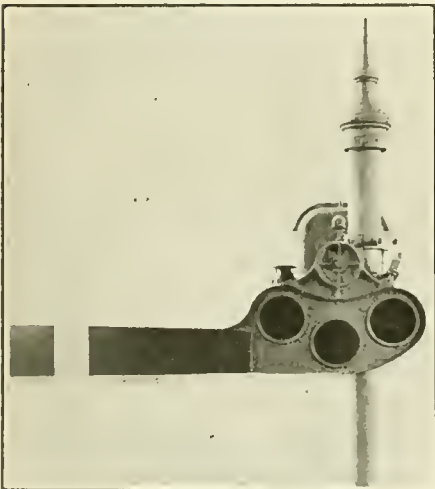

STOP SIGNAL.

a train of gears, with ratio 120 to 1, and a circuit controller for retaining the signal arm in caution or proceed position. This mechanism is worked by three-volt accumulators.

The Britishers have been long in recognizing the true value of the three-position upper quadrant electric signal, and the introduction of these from this country may cause a vast improvement over the lower quadrant signals hitherto universally used in England.

### The Light of Other Days.

By J. E. ALGER, READING, MASS.

While every number of your valuable journal is very interesting, an occasional article appears that takes me back to the light of other days. I began railroading in 1868, and I am at it yet. Your recent article on Soft Hammers was a cracker, and brought back the methods in vogue

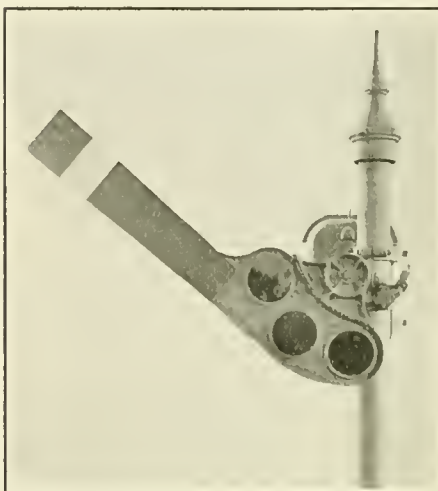

CAUTION SIGNAL.

in the old days very vividly. Among tools my father had, there are two made of copper, one a drift for driving out rod keys, and the other a hammer used on the old style of heater cocks that were used in keeping the pumps from freezing. The hammer has a slot in one end for turning the cock after it was loosened by a slight tap on the bottom. These are the implements that he used from 1853 to 1864. The word Union is stamped upon them. This does not refer to the Federation of States, but to a locomotive of that name that he ran for many years. Your reference to the silken softness of the finished rod straps is correct and we of the olden time know what it means. Not only the straps but the entire rod, and guides and every piece of finished work had to be draw-filed, and finished with three grades of emery cloth and oil, until they shone like a mirror. Nuts had to correspond in flawless brilliance, and woe to the man who allowed the face of a hammer to come in contact with the burnished splendor of the metallic brightness. His name was changed to Walker without ceremony. Then the cylinders, steam chests, dome and sand-boxes shone like pure gold, with bands of similar lustre around the boiler. Some had shining bands around the smoke stack.

These artistic touches even ran along the running boards. The bolt holes in the board were recessed or countersunk so that the heads of the bolts were easily filed smooth and disappeared in the immaculate polish. Of course these were the days when every engineer had his own engine, or he thought it was his own,

and the rivalry for outside show was keen and the degree of perfection constantly aimed at. Now it is not unusual to have three or four changes of a locomotive in 100 miles, and the only hope is that the last one will get him home, when the hydraulic bolt starter will get its work in, and the soft hammer might as well be in the museum among other prehistoric curiosities. So it is that the artistic gives way to the utilitarian, and the older engineers feel like lobsters that do not know whether they going backward or forward.

According to the *Brass World*, lathe tools are now made which surpass in hardness those made of the finest special steels, and which outlast them many times in cutting metals. They are composed of an alloy of cobalt, chromium, and tungsten invented by Elwood Haynes, of Kokomo, Ind., president of the Haynes Automobile Company. These alloys are also used for cutlery and take an edge equal to good steel and yet are very non-corrosive.

### A Flash of Truth.

At the meeting of the Chicago Elevated Railroad section of the A. E. R. A., M. J. Feron, general superintendent of transportation, said that the method of disciplining employes by further education rather than by summary methods is not only a paying proposition from a business standpoint, but is a duty which is due the employes.

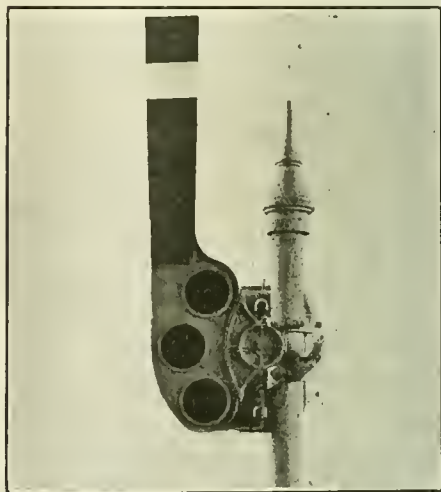

PROCEED SIGNAL.

### Railroad Agency at Havana.

Officials of the Queen & Crescent Route express the opinion that there is a great opportunity for American manufacturers in Cuba, and that with excellent facilities for the delivery of goods they should be able to obtain and hold permanently a large share of this trade. The Cincinnati, New Orleans & Texas Pacific has rail-and-water routes via New Orleans, Mobile, and Key West, and also maintains the all-rail route via Key West.



# Department of Questions and Answers

## Welding Flues.

S. G., St. Louis, Mo., writes: Mr. Stafford's instructions in regard to the proper method of attaching staybolts, published in a recent issue of RAILWAY AND LOCOMOTIVE ENGINEERING, was excellent and we are adopting his methods here, but we would be further pleased to have some advice in regard to welding flues. What, in your opinion, is the best practice? We have occasional trouble with leaky flues. A. At the present time the general practice in setting and welding flues appears to be for the back end, to insert a copper ferrule in the hole, then roll, expand and bead the flue, after which the joint is carefully cleaned and welded lightly on the edge of the bead. Some experienced men claim that copper ferrules need not be used, nor flue beaded—claiming that welding by the electric process is enough. This process is generally indicated as being mostly used in this class of work. Flues in the front sheet are not welded, but rolled, and about ten per cent. of them beaded. Both electric and acetylene processes are being used, but their comparative merits seem to be matters of individual opinion. Tapering or counter-sinking of the flue holes in the back flue sheet has been in practice, but this is not now deemed necessary. In all cases a hydraulic test is applied at least twenty-five per cent. higher than the working pressure of the boiler, and if leaks are discovered, the leaking parts, of course, should be rewelded, and another test made, and when no leaks appear in testing, there is rarely any trouble afterwards.

## Defective Distributing Valve

A. L. M., Richmond, Va., writes: Will you kindly tell me what is wrong with a No. 6 distributing valve that will not apply with a light reduction in brake pipe pressure and when it does apply after about ten pounds reduction, it makes a loud rumbling noise at the time it is applying the brake? A. These are two separate disorders, the failure to apply with the light reduction may be due to excessive friction in either the equalizing or application portions of the distributing valve or it may be due to equalizing piston packing ring leakage. The loud rumbling noise that you probably have reference to, is made by the application piston traveling rapidly from application to lap or partial release position. This is usually the result of a loose fit of the collar on the application piston in the cavity in which it operates. This collar is supposed to restrict the flow of air from the main reservoir by the way of the brake cylinder connections in the distributing valve to the back, or application side of the application piston in order to prevent the action you have noticed and when it is filed off or reduced in size through some mistaken

idea, this noise usually occurs and soon results in wearing out the application portion of the distributing valve. Renewing the application piston usually overcomes this trouble while the same trouble is frequently aggravated by a very weak application piston spring and sometimes by a leaky exhaust valve through an exhaust valve spring missing.

## Defective L. Triple Valve

A. L. M., Richmond, Va., writes: What is wrong with the type L. triple valve when it will apply with a full twenty pound brake pipe reduction, but will not apply with the same amount of brake pipe reduction if made 3 or 4 pounds at a time, the supplementary reservoir being cut out? A. This may be caused by a leaky brake cylinder packing leather which can be detected in the usual manner. The real trouble with such a brake cylinder is in a defective expander ring or lack of lubricant in the cylinder. This may also be caused by a leaky triple valve piston packing ring but it must necessarily be a very bad one and through the use of test racks very few valves of this kind go into service, besides under such conditions the valve would likely fail to release after it has been applied. If the brake cylinder is in good condition and the brake releases after it is applied, it indicates that the trouble is with the triple valve, check valve leaking very badly or being off its seat. This would allow air from the auxiliary reservoir to flow back into the brake pipe through two separate sources or rather flow back into the brake pipe during an attempted application at the same rate that the reservoir is charged from the brake pipe, and result in the action you have mentioned. If the check valve is off its seat or stuck open, it can be told by its failure to make the buzzing noise when the auxiliary reservoir is charging preparatory to an application of the brake.

## Hauling Dead Engine

W. C. B., Garrett, Ind., writes: Will you kindly explain how a dead engine may be hauled in a train of cars when there is no dead engine fixture or if one of the pipes leading to it happens to be broken off? A. In case of this kind it will only be necessary to plug the brake pipe exhaust port of the automatic brake valve and unscrew the adjusting nut or regulating hand wheel of the brake pipe feed valve so that the feed valve adjustment will be about 10 or 15 lbs., and the brake valve cut out cock should be left open, and both brake valves left in running position as usual. In this way the main reservoir will be charged by a backward flow through the feed valve and when the brake pipe reduction is made from the engine

hauling the train, the feed valve of the second engine being set at 10 or 15 lbs. will prevent main reservoir pressure from the second engine from entering the brake pipe. The plug in the brake pipe exhaust port will prevent the equalizing piston from being lifted from its seat when the brake pipe pressure is increased by the head engine during a release of brakes.

## Get Ready for Promotion

RAILWAY AND LOCOMOTIVE ENGINEERING has always been an educational paper. That is, it has adhered to the policy of publishing information of a positively practical character, the kind of matter that teaches all lines of mechanical men the science underlying their business and those of the lower ranks to pass examinations that lead to promotion.

We have in our files, records of many firemen who passed examinations that promoted them to the right hand side of the engine through the help given them by RAILWAY AND LOCOMOTIVE ENGINEERING. The tendency to require firemen to pass stiff examinations before according them promotion is growing and every ambitious fireman ought to keep that in mind.

What would "you" do in case of a broken valve yoke, or a broken eccentric out on the main line and avoid excessive delays?

This question was asked a class of firemen up for promotion on a prominent line.

Out of six men only one answered this question, and so satisfactorily to the officials that his promotion followed, while the other men were set back six months, when another trial would be given them.

The lucky fireman attributes his success to RAILWAY AND LOCOMOTIVE ENGINEERING.

A \$2.00 investment for a year's subscription not only netted him a promotion but increased his daily earning 50 per cent.

The general road foreman of engines of a trunk railroad writes us: "I encourage our engineers to read RAILWAY AND LOCOMOTIVE ENGINEERING and can generally tell the readers of the paper by the ready answers they give under examination."

A prominent railroad manager attributes his success in life to the spurring up to do something for himself received from RAILWAY AND LOCOMOTIVE ENGINEERING.

Do "you" want to advance and improve your condition? RAILWAY AND LOCOMOTIVE ENGINEERING has helped many men and can help you. Its columns are full of bright things every month, and there is "nothing just as good" published.

Be wise and send in your name with \$2.00 to this office or give it to our nearest agent.

# Oxy-Acetylene Welding and Cutting

## Illustrations of Operations and Costs

No better illustration could be given of the adaptability of the use of the oxy-acetylene in cutting metals than in the appliance shown in Fig. 1, and known as the Oxygraph. As perfected by the

kinds of slotting machines. In addition to the machine as shown, it is equipped with an electrically propelled rolling tracer, which can be guided along the lines of a drawing, and the cutting flame

narrow and perfectly smooth, and the movement in curves or acute angles is perfect, and is of great advantage wherever steel is cut in irregular forms. The motor power required to move the apparatus is of the lightest kind, an electric lamp connection or small battery being sufficient. As shown in the illustration it may be furnished with a double pantograph frame, fitted with two cutting torches for making duplicate cuts at the same time, and is especially designed for heavy work. In point of precision it cannot be approached by hand work, as the operator does not require to come near the torch or torches, his work being to guide the pantograph over the lines of the enlarged drawing, the cutting flame following the direction thus guided over a smaller and, consequently, more exact line of movement.

Coming to the use of the oxy-acetylene welding and cutting process and equipment, we reproduce some illustrations of repairs recently made in the shops of one of the large Eastern railroads. Fig. 2 shows one of the pieces in side sheets taken out above half side sheet seams. The cutting of 40 feet in length of  $\frac{3}{8}$ -inch metal occupied two hours, with a consumption of oxygen amounting to 130

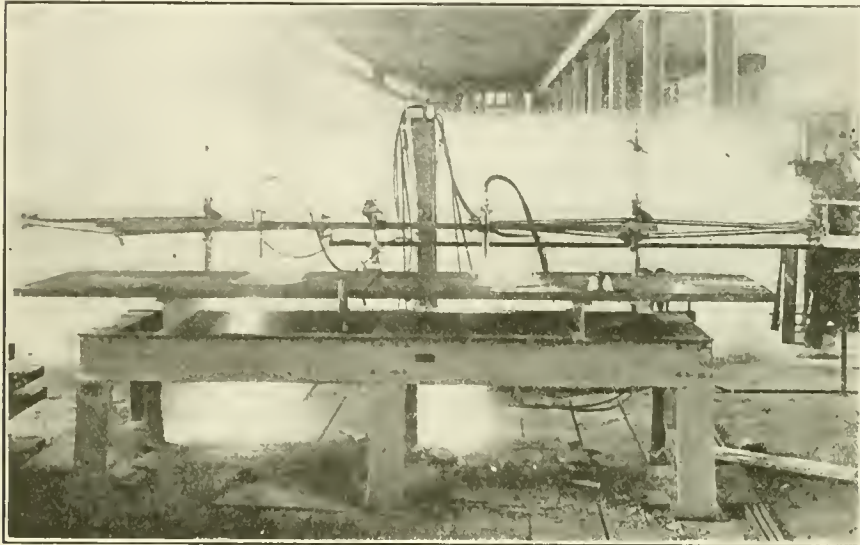

FIG. 1. VIEW OF OXYGRAPH IN OPERATION.

Davis-Bournonville Company it will cut steel several inches in thickness at the rate of from six to twelve inches per minute. Its capacity is such that it readily replaces several of the most powerful

or flames will make an exact reproduction of one-half the dimensions of the drawing. The cut made by the flame is

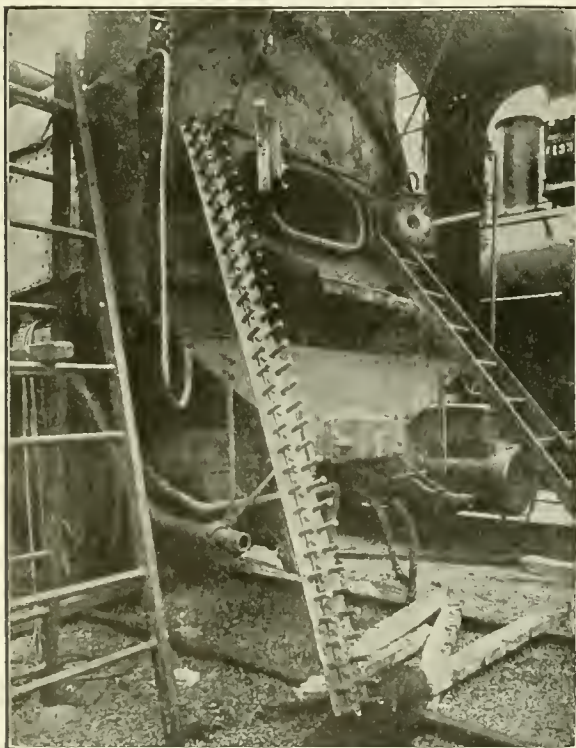

FIG. 2. VIEW SHOWING ONE OF TWO PIECES CUT FROM SIDE SHEETS OF BOILER, PREPARATORY TO WELDING IN NEW PIECES BY OXY-ACETYLENE.

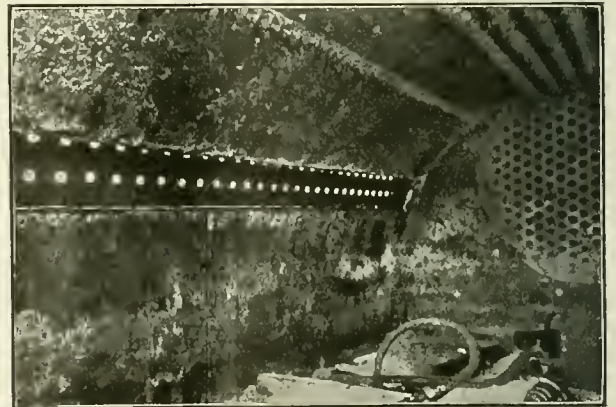

FIG. 3.



FIG. 4.

cubic feet, the approximate cost being \$3.20. Fig. 3 shows one side sheet with a piece cut out, and Fig. 4 shows the patch welded in. To replace the particular patches referred to, the time occupied was 20 hours, about 800 cubic feet of oxygen was required, involving a total cost of \$15, with an additional expenditure of \$33.71 for removing and replacing stay-bolts, making a total expenditure of \$48.71. If these patches had been applied by the old method—that is, without the use of the welding and cutting torch—the accurately estimated cost would have amounted to \$88.26. The opinion of the boiler maker experts that patches put on by the old method was that they would not have lasted for any length of time, and it would soon have

the spokes of a locomotive cast steel driving wheel. The time occupied in making the repairs by completely welding the cracks was two and a half hours, with a consumption of 200 cubic feet of oxygen, at an approximate cost of \$7. The subsequent strenuous service of the locomotive has not shown in the repairs any indication of further fracture. In this connection it may be added that in many tests of welded parts purposely tested all samples broke in the solid plate, the welds remaining uninjured.

These illustrations might be added to as there are very few parts of the modern high powered locomotive that are not subject to fracture, and all have been successfully repaired with the use of the oxy-acetylene appliances; in some

mobile engine so that the correct proportion of gases are brought together for each particular size of tip, assuming a perfectly neutral flame in all of them. This is of real importance, as torches that have the mixing device in the head instead of in the tip, produce results corresponding with the use of one sized carburetor for all sizes of automobile engines, instead of varying them in size with the volume of gas used.

In conclusion, it may be added that for autogenous welding the oxy-acetylene process can be made invaluable to every variety of work in practice, and almost every kind of metal in service in railways, but to be successfully employed it must be applied with intelligence. The art is still in a state of development, but many

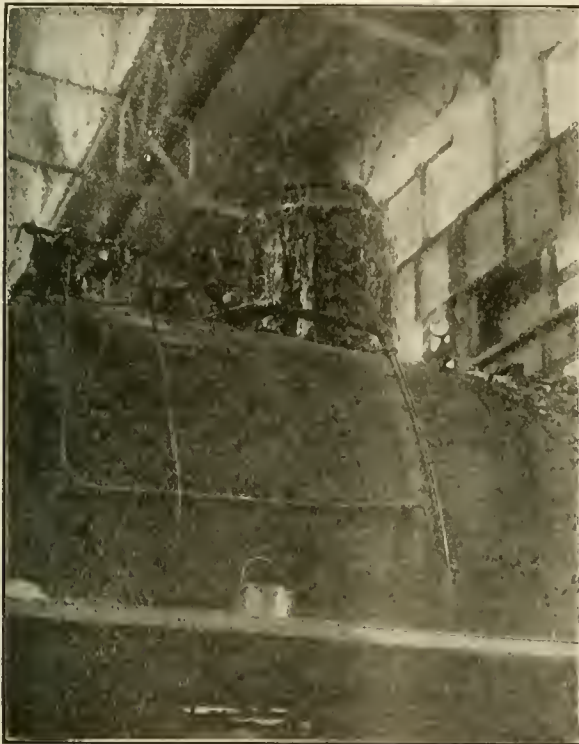

FIG. 5.



FIG. 6.

been necessary to put in two new side sheets at a cost of \$404.04. The boiler was subjected to a water pressure test of 275 pounds per square inch without any leak of any kind apparent in the welds.

Fig. 5 shows a view of a locomotive steam dome, which had ten cracks reaching from the rivet holes to the caulking edge. The time occupied in the repair work was one hour, with a consumption of 50 cubic feet of oxygen, with a total approximate cost of \$1.75. Without the welding appliance it would have been necessary to construct and attach a new dome to this locomotive at a cost of \$125, and would have necessitated keeping the locomotive out of service at least for several days.

Fig. 6 shows repair work on four of

cases, as in serious cylinder fractures, complete repairs have been made without removing the cylinders from their places, and in every instance with the most qualifying results.

It should be borne in mind, however, that the perfect repair of these and other serious fractures can only be expected where the apparatus is of the best, and employed in the hands of a properly trained mechanic. Recent improvements in the apparatus has had much to do in reaching that degree of perfection now attainable. In this connection we might state that the enterprising company that we have already referred to has continuously made improvements on the welding torch, the basic feature of which is that each tip has a mixing device similar in function to the carburetor of an auto-

mobile engine, especially those arising from the results of expansion and contraction are being overcome. This has arisen, of course, from the experience that comes from practice, and the knowledge in preheating some of the heavier parts to be welded, the amount of variation in the different thickness of metals, the danger of cracking in cooling, and other details that at first were difficult to foresee, but are becoming more and more within the possibility of a complete mastery, and, from a growing degree of willingness to receive instructions from those who are best qualified to instruct.

---

He knows the truest way to teach  
Who puts great thoughts in simple  
speech.

# Railway Engineering

A Practical Journal of Motive Power, Rolling Stock and Appliances.

Published Monthly by

**ANGUS SINCLAIR CO.**

114 Liberty St., New York.

Telephone, 746 Rector.

Cable Address, "Locong," N. Y.  
Glasgow, "Locoauto."

**Business Department:**

ANGUS SINCLAIR, D. E., Pres. and Treas.  
JAMES KENNEDY, Vice-Prest.  
HARRY A. KENNEY, Secy. and Gen. Mgr.

**Editorial Department:**

ANGUS SINCLAIR, D. E., Editor.  
JAMES KENNEDY, Managing Editor.  
GEO. W. KIEHM, Associate Editor.

**London Representative:**

THE LOCOMOTIVE PUBLISHING CO., Ltd.,  
8 Amen Corner, Paternoster Row, London, E. C.

**Glasgow Representative:**

A. F. SINCLAIR, 15 Manor Road, Bellahouston,  
Glasgow.

**SUBSCRIPTION PRICE**

\$2.00 per year, \$1.00 for six months, postage paid in the United States, Canada and Mexico. For other parts of the world, \$2.50, or ten shillings. Single copies, 20 cents. Remit by Express Money Order, Draft, Post Office Order or Registered Letter.

Mailing address can be changed as often as necessary—always give old and new address, and if you subscribe in a club, state the name of the agent.

Please give prompt notice when your paper fails to reach you regularly.

Entered at the Post Office, New York, as Second-class Mail Matter.

## Railways as Manufacturers.

Owing to a report, recently circulated, concerning the great profit made by one of our locomotive building companies, there has been a revival of the frequently discussed subject, why should railway companies not engage in manufacturing their own equipment?

The aggregation of small railway lines into great systems has for years aroused the temptation among the large companies to engage in executing the construction of their own rolling stock, thereby, to enjoy the profits of the manufacturer. The step from the making of repairs to the production of entirely new equipment of rolling stock is an easy one and there are some reasons to encourage railway managers to take it. Engaging in manufacture may aid in filling gaps of idleness for the permanent force of men and an extensive plant of machinery. A move of that kind is generally strongly urged by those in charge of ordinary repair operations because it increases their responsibilities and their power.

There can be little doubt that there are circumstances under which railways can and do find it profitable to engage in man-

ufacturing. This is more likely to occur in localities distant from centers of industry. But, on the whole, the necessity is not very frequently felt. There are many good reasons, on the other hand, why it is not conducive to true economy to add the work of the producer to that of the carrier. The principal one is that it renders the organization of the railway diversified, more extensive and, therefore, more difficult to handle. Since they are not trained to it and are not experienced in it, the railway managers must delegate the responsibility and the direction of the work to subordinates, whose operations, deprived of the consistent and vigilant care that, like that of the owners of private establishments, naturally do not come up to the highest standard of efficiency. Supplies are not bought so advantageously; costs are not so closely followed and so accurately determined; the grade of work is not so evenly maintained, and thus the profit of the manufacturer, which it was the object to save, dwindles down to nothing. In the relations between the manufacturing department of a railway and the officers who receive the product that beneficent attitude of hostility between buyer and seller is lost. Demands are less heeded and the stimulus of rivalry between competitors does not push the maker to meet, or even anticipate, the requirements of the user. In the absence of an active interchange of ideas with many purchasers holding different views, there is a tendency to fall into certain grooves. The red taping of a great organization is apt to stifle the progressive spirit in what is, after all, a minor department in it. The incentives which constantly use a private concern to do the best work at a minimum cost are largely lost under such circumstances. We do not deny that there are cases on record where the exceptional qualifications of individual officers have made model institutions, but they are exceptions and rarely outlast the term of office of the one person to whom the success was due.

There is one fact upon which there is a good deal of misapprehension on the part of ambitious railway managers. They have an exaggerated idea of manufacturers' profits. Taking reasonably long periods, concerning times of great activity and of depression, their returns are not much, if any, greater than those on the actual cost of the railways. The latter, if they do possess available funds, could probably, in the majority of cases, find more profitable employment for them in improvement of property and of service or in extension into new territory. Considering this in connection with the point of operation against cheap production, under comparatively uninterested management, we believe that railway men will be wise when they leave manufacturing to manufacturers and confine themselves to the operation of railways.

## Eight Hours a Day.

It is not our desire to thrust our personal views in the vortex occasioned by the demand of the railroad brotherhoods for shorter hours, or to join in the demand for larger legislative powers, because we are well aware that the question is in more qualified hands than ours, and we await the result with that degree of complacency that comes to those who believe that the world is moving onwards, not by reason of legislative enactments, but in spite of them. Legislatures have hampered the railroads, and enterprises of great pith and moment have been turned aside by the inter-meddling of politicians, who would have served their country better in less exalted situations. After protracted struggles a few roads here and there have been able to secure the privilege of raising the transportation rates in a small degree, and we claim with all the unction that we possess that if these increases are necessary now, they were more necessary eight years ago when traffic was much lighter, and expenses nearly as high as they are today.

This lamentable policy of hindrance and repression should be seen by our statesmen, if there be any of such amongst us, and the great mass of the people are of opinion that if eight hours a day is a good thing for overpaid government employees, surely it could not be a bad thing for those employed in private enterprises. Even the eight-hour day is not strictly regarded in Federal, State or municipal offices. We know of hundreds who report after nine o'clock in the morning and leave before five in the afternoon. One hour at mid-day reduces this to less than seven hours, and the annual vacation periods ranging from two weeks to three months, with all the multiplex and curious holidays thrown in, reduces this estimate to a little over six hours, and we hear of no particular complaint, other than the familiar wail of the tax-payers, and even they unite like a solid phalanx to fall upon the bent back of the rent payers.

Then there is that voiceless multitude for whom nobody speaks—that array of skilled and unskilled workers in factories and cellars and mines, those who are the hardest workers. What have they but a constant cry for a greater efficiency, and an unbroken ten hours with their noses to the grindstone? They never dream of a holiday. Who ever heard of a fireman or a blacksmith's helper getting a holiday? And yet who has more need of it, not only in the dog days, but in other days? Surely the divine spirit that uttered the blessed words: "Come unto me, all ye that labor and are heavy laden, and I will give you rest," finds no echo in our legislative halls, and this is not to be wondered at because there are indeed very few among our legislators who know

what a real hard day's work is, unless it be working in the interest of the "pork barrel."

Probably, when the workmen learn to vote for men of their own hard training to represent them at Washington, we may look for something in the way of equality, but, having had some experience among them, we are not praying for miracles. Capable working men are not lacking, as all who know the heads of the brotherhoods are well aware, but even their eloquent voices lifted up in the localities where they live would be like the voice of one crying in the wilderness. They could not secure a nomination. This gratuity is preempted by the men who have grown fat on other men's brains, by embryo lawyers whose fathers can purchase preference for their sons, and to whom the workmen will bend the knee as the wanderers in the desert of Arabia bent the knee to the golden calf. We are almost tempted to say, as was said of old: "Ephraim is joined to his idols; let him alone," but we are convinced that a spirit of greater enlightenment and mutual regard cannot fail to beget a kindlier feeling towards the common interests of all.

#### Electricity's Dangers.

We have recently read a statement to the effect, that had a certain disastrous collision between two steam operated railway trains happened to electrically operated trains the damage to life and property would have been much less severe than it was. We have no intention or desire to detract from any merit that operation by electricity may possess, but our experience moves us to the opinion that electrical operation is just as dangerous as operation by steam.

The late George Westinghouse advocated the use of electricity for numerous industrial purposes, but he was not entirely favorable to the employment of electricity for train operation. Commenting upon a serious train accident that happened several years ago he wrote:

"As a matter of fact, with an electrically operated train, the risk of accidents, judging from past experience, will be increased rather than diminished because of the presence of the heavy electrical machinery which it is proposed to attach to several cars of each train. Already there have been many serious collisions with great loss of life between electric cars, while there have been numerous cases in New York and other places in which cars have been quickly destroyed by fire which have resulted from some derangement of the electrical apparatus or circuits, and in some instances so quickly that passengers have had scarcely time to escape to the street.

"It should be borne in mind that the electric energy required to operate a heavy train is sufficient to melt a consid-

erable bar of iron, or to start a dangerous fire, if anything goes wrong upon a car of ordinary combustible construction, much more readily than the car stove, the use of which has been abolished by law. Therefore, if a collision were to occur between two electrically fitted trains, each having several combustible cars thereof fitted with electrical apparatus and carrying electrical circuits throughout, there could be an accident of so serious a character as to start an agitation having for its purpose the abolition of the use of electricity altogether, or at least to compel the railway companies to abandon the use of combustible cars fitted with electric motors.

"The destruction by fire of a car or train upon a street or upon a level is one thing, but such an occurrence upon an elevated railway or in a tunnel can have consequences the contemplation of which should lead to wise regulations governing the construction and use of electrically propelled trains and thereby insure to the public the rapid development of electric traction."

From what we have seen of train collisions, we are inclined to think there is no choice about the power employed. The amount of destruction will depend upon the speed of the train.

#### Treatment of Tool Steels.

Persons who have for years been in the habit of lingering about the tool dressers' forge, can hardly fail to be impressed with the conflicting ideas that the different blacksmiths hold, concerning the best methods for treating various grades of tool steel in order to insure the best results.

Ever since he was an apprentice machinist, 30 years or more, the writer has always been allured to the tool dressers' forge and the mysteries of their art, as cherished by different blacksmiths, have been very diverse. At one time the tool dressers professed that there were profound secrets connected with their art, but these have vanished of late years, because, as one victim explained, the cursed technical papers give all the secrets away.

We have collected numerous descriptions of how the tool dressers' art can be most successfully followed, and we consider the Ryerson method the simplest and least likely to result in failure. The principal directions are:

It is an acknowledged fact, by large manufacturers and users, that 99 times out of 100 the trouble experienced with tool steel lies in the way the steel is hardened, and not with the steel itself, and very often the best steel entered in a test will not stand up the longest on account of carelessness in hardening.

It is always a good plan to order steel thoroughly annealed, instead of as it comes from the hammer or rolls, as the

long annealing to which it is subject at the mills gives it a uniformity and freedom from strains that it is practically impossible to obtain in the ordinary shop. High-speed steel can be made nearly as common steel by proper annealing, so that it is a comparatively easy matter to machine and forge tools from it, whereas poor annealing will greatly limit its utility.

In forging air-hardening steel, heat the tool to a bright cherry red, merging into dull yellow, taking care that the heat is driven uniformly through the metal. Do not heat further back than is necessary to shape the tool, yet far enough to avoid doing any work upon the shank below a bright cherry red. After forging lay the tool down to cool to relieve the forging strains.

For hardening, heat the nose of the tool to a cherry red, and then as rapidly as possible bring the cutting edge to a white sweating heat, about 2,200 degrees Fahrenheit. Be sure to have a good body of fire between the tool and the tuyere, so that the air will not strike the cutting edge of the tool. Then place the tool immediately in a cold, dry air blast, such as is produced by blower or compressed air.

If the nose of the tool is to be used, it should be held on a direct line with the blast, but not too close. As soon as the steel stops sparking turn on the full blast of air pressure and hold the tool within about two inches of the nozzle until quite cold. It is advisable to have the cold air blast as near as possible to the heating arrangement so that the tool can be transferred immediately from the fire to the blast. Do not let the point of the tool shift from the direct air current until cold. If the tool is laid down while hardening it must be fastened so that the blast will not shift it. After hardening, the tool must be thoroughly ground, as the high heat forms a thick scab which must be removed entirely. A free cutting dry wheel is to be preferred. If the tool is wet it is necessary to use plenty of water. Avoid blurring the cutting edge. The treatment of tool steel, like everything else, requires care and time if it is to be done properly, and hasty and careless methods always bring poor results.

#### Pooling Engines.

When railway train service was first instituted it was at once assumed that one regular crew should be employed in operating each individual locomotive, and years passed before the idea of pooling engines and their crews was proposed. As traffic developed, however, and it was found that the same crew could not always follow a locomotive, when a rush of business required that the engine should be kept at work without intermission, the practice grew up of keep-

ing the engines on the road without delays for repairs or rest, and so the custom known as pooling engines became the regular practice on some railroads.

Railway managers argued that the motive power represented so much capital and that it was poor business to keep engines idle merely to give the crew rest and so the practice of continuous runs of the engines with relay crews became the rule on many lines. After a time experience demonstrated that the saving of expenses resulting from keeping the engines constantly at work was not so great as had been anticipated. When one set of men did all the work of operating a locomotive, the expense for coal and supplies was smaller than with pooled engines and the cost of running repairs was much heavier. Then those in power realized that pooling was not a profitable practice except under special conditions. This led to the practice of pooling being abandoned especially for passenger service and several railroads have returned to the old method of assigning regular crews to engines. The practice of pooling is on the wane.

Another thing that has proved unfavorable to pooling is the enormous increase of size of engines. With the old 18 x 24-inch eight wheel engines, repairs were very light at the end of a journey and most of the engines could be turned and sent out again with very little delay, but the engines now handling most of our freight trains require repairs after each trip that cause several hours delay. A prominent superintendent of machinery, talking to the writer on this subject, expressed himself quite freely in favor of returning to the practice of assigning each engine to a regular crew. For, said he, a regular crew takes better care of engines than men in a pool and the modern engine calls for all the care that can be given, if the operating expenses are to be kept within moderate limits.

#### Reinventing Useful Appliances.

A good friend of ours appears to entertain a tendency to find nothing new in articles which the Patent Office *Gazette* illustrates and describes as something new and useful. Reading men with long memories are apt to find every invention offered to the public as being "old as the hills." That is our friend's favorite expression.

Aside from the question as to the originality or utility of any invention, there is, generally speaking, but little "new under the sun" of the great majority of inventions, as they are mostly improvements on some invention that has done its part for years. Cutting off steam in the cylinder of a steam engine with a slide valve, for instance, is old, and the valve is the most important factor used, but new and some of them valuable ways of

accomplishing the same end are constantly brought forward, and usually, along with one novel feature, several common ones are used. But because there is little new in a valve gear—or other mechanical device—it by no means follows that it is not valuable, or that the inventor that adds that little is not deserving of credit. Even if he adds nothing except brains enough to make something operate satisfactorily that would not do so before, he gives it all the value it possesses.

A great deal is said in one way or another about re-inventing ancient devices, but if by this means anything hitherto useless is made useful it ought to be satisfactory. It is difficult to see, as is generally inferred, that some one has been defrauded in the operation. The value of any mechanical appliance is in what it accomplishes, not in the combination of parts or pieces, and the man who makes it work, by additions or amendments, is the one who benefits the public. Too much solicitude for those who buy and use such appliances is apparent. They judge by results, and are not likely to be defrauded to any extent. If the device, whatever it may be, possesses no value, it is not likely to sell, and the one most injured is the one who attempts the selling. If it is of value; the fact of its being old or new does not change its value.

It is undoubtedly true that no one is likely to take especial pains to divide the credit for some useful invention, or to go back in the effort to find out where the credit actually belongs. There may sometimes be injustice in this, but in these matters, as in most others, success is all that counts, because it is all that gives value.

#### Serious Accidents.

When accidents happen that result in personal injury, people naturally wish to know particulars. They want to know under what circumstances travelers and others are most likely to get hurt. Insurance companies investigate carefully all accidents resulting in personal injury. Some time ago the Chamber of Commerce of Rochester, N. Y., compiled accident statistics that are highly interesting.

The classification is of 100,000 accidents on which several casualty insurance companies have paid out \$7,455,568. Heading the list, as might be expected, are the travel accidents, with a total of 29,726, of which 24,936 were railroad; 4,356 street car, and 434 steamboat and steamship accidents. But the type of accident to come second—that of falls—is distinctly surprising, the total being 18,367 were falls on the pavement, and 1,946 from chairs and ladders. Accidents having to do with road carriages, wagons and horses, come third, with a total of 8,135,

while the number of automobile accidents was only 1,620.

It is likewise interesting to note that 209 of the accidents were caused by tripping over door mats and rugs; that there were 4,217 cases of fingers crushed in various ways, 2,969 burns and scalds, 2,877 athletic accidents, 681 bathing or drowning accidents, but only 579 gunshot wounds.

In the waters around New York city, 700 persons lose their lives yearly, most of the accidents resulting from reckless idiots standing up in boats causing them to capsiz.

#### Laws and Relations of Heat.

Familiarity with science makes slow progress and keeps moving forward, although many people associate science with infidelity and denial of religion. Yet true science rests on a secure foundation and every advance in intellectual education has been the effect of considerable acts of scientific discovery. The manifestations of heat ought to appeal to all persons connected with railway operations, yet we frequently hear sneering remarks made upon those who try to explain how heat acts and how its forces have originated.

In the study of nature two elements come into play, which belong respectively to the world of science and the world of thought. We observe a fact and seek to refer it to its laws, we apprehend the law and seek to make it good in fact. The one is theory, the other is experiment, which when applied to the ordinary purposes of life, becomes practical science. Nothing could illustrate more forcibly the wholesale interaction of these two elements than the history of the steam engine. If the steam engine had not been invented, we should assuredly stand below the theoretic level which we now occupy. The achievements of heat through the steam engine have forced with augmented emphasis the question upon thinking minds—what is this agent by means of which we can supersede the force of winds and rivers, of horses and of men?

Heat can produce mechanical force, and mechanical force can produce heat. Some common quantity must therefore unite this agent as the ordinary forms of mechanical power. This relationship established, the generalizing intellect could pass at once to the other energies of the universe, and it now perceives the principle which unites them all. Thus the triumphs of practical skill have promoted the development of philosophy. Thus to the interaction of thought and fact, of truth conceived and truth executed, we have made our science what it is—the noblest growth of modern times, though as yet but partially appealed to as a source of individual and national might.

Interest in the various manifestations of heat has touched the workers of the

world very slowly, but the systematic culture of the industrial world will receive increasing attention year by year. Science does not need the protection of our active workers, but it desires their friendship on honorable terms. It wishes to work with them towards education which aims at the bettering of man's condition. Science must grow. Its development is as necessary and as irresistible as the motion of the train. It is a phase of the energy of nature and as such is sure, in due time, to compel recognition of all intelligent minds.

#### Tin Brought the Steam Engine.

It seems curious considering the metallurgical opulence of the American continent, that we continue to be dependent on English mines for nearly our entire supply of tin. Every few months we notice reports intimating that tin ore in paying quantities has been discovered in various localities in the States, and those interested in the new mines predict that their product is going to revolutionize the tin trade immediately, but somehow the promises end in nothing. The price of tin runs so high that it offers rich encouragement to anyone who may discover good ore, but the search continues to be fruitless. Tin ore in small quantities has been found over a wide area, but the market is supplied principally from Cornwall in England, Banca in the East Indies, and Malacca in South Asia.

Tin is a metal which has performed a most important purpose in the world's history. Combined with copper to form bronze, it was doubtless the first metal brought into the service of man, and implements and weapons constructed from this alloy were used during a much longer period than iron or steel have yet served art or war.

The bronze of the Greeks and Romans consisted of about five parts of copper to one of tin—a proportion which produces an alloy of the greatest hardness. The men who worked the metals in those early times must have attained great skill in the manipulation of alloys, for they were able to harden bronze articles so that a good cutting edge could be held. The necessity which the old Eastern civilization had for tin, first brought the British Isles into note, for tin was obtained from Cornwall long before the Christian era. Herodotus, who wrote 450 years B. C., is supposed to refer to Britain under the name of Cassiterides, which name is similar to the Greek word for tin. The alloys which are formed with tin were comparatively easy to work, and gave early races tools, the great aid to the development of civilization long before the science needed to refine iron ores was reached.

The skill, acquired by the use of even

crude bronze tools, led the way to more difficult lines of metal working. It seems questionable if the world would ever have reached the iron and steel epoch if the chasm between it and the stone age had not been bridged by the bronze age. In the latter period tin greatly accelerated the wheels of progress by providing the necessity which brought the practically successful steam engine into existence. The long-continued demand on Cornwall to supply tin to the world, from the times away back into mythical antiquity into modern days, had, by the beginning of the eighteenth century, sent many of the mines away far down into the bowels of the earth. There, though tin ore was plentiful, water was more so, and the means of draining the latter out were so crude that proprietors of rich mines had to abandon their property because they could not keep out the water from the workings. When the primitive form of atmospheric engine was first brought into use, it would have continued a mere experiment—a toy for disquisition and experiment of learned theorists—had pumping Cornish mines not given it profitable, practical work to do. No kind of work could have better fitted the Newcomen engine than pumping water, where regularity of motion was of no great consequence. While doing this sort of duty opportunities were given for improving the machine as experience dictated. But for the teaching received from the rough atmospheric engine, constructed by Newcomen, Watt would have had no use for a separate condenser for his great invention, and Oliver Evans could have invented no high pressure steam engine for want of the train of mechanism that formed the steam engine.

#### First Railroad Operating.

A common complaint of today is the interference of politicians with the operation of railroads, a practice that is as old as railroad operating. Some 72 years ago the first division of what is now the Pennsylvania Railroad was opened between Philadelphia and Columbia, a distance of 81 miles. The principal inhabitants of the country at that time were farmers, who had many politicians among them, and they had an idea that the railroads should be operated in their interests.

The railroad was built by the State of Pennsylvania, and it was operated as a public highway, where any person could run a car on paying the fixed charges. The motive power was mules, and the method of moving trains was decidedly primitive. The track was single, and "trains," which generally consisted of a single car, passed each other on turn-outs. Half way between the turn-outs was a post, and trains which first passed this post had the right of way to the next turn-out. When two

trains were approaching each other, it was an important matter to pass the post first, and the zeal to obtain the resulting advantage often led the "engineer" to urge on their mules so vigorously near the vantage point that trains frequently tried to pass each other on the same track. When this happened bloodshed would often result, for the engineers would get down and pound each other, and not infrequently the passengers would take part in the melee.

Numerous attempts were made to introduce better "rules of the road," but our pioneer railroad men do not appear to have been amenable to discipline, so about the time the locomotive displaced the mule, the State had to take the work of operating into its own hands.

#### Doers of Common Things.

We judge a meteor not by the brilliancy of a few of its great lights, but by the standing of its masses, by the intelligence of those who produce common things. The millionaires of a nation do not make it rich, nor does the standing of a half dozen thinkers constitute a valid claim for intelligence. The financial condition of the men who work establishes the condition of a nation as to wealth, as the mental condition of the people, as a whole, constitutes its intelligence.

Workingmen are apt to think that education to be of much avail, must be had through some regular institution of learning. Such institutions play an important part in the affairs of the world, but other means of acquiring knowledge are no less influential. Few of the men who are leaders in the industrial and railway world have been college bred. The world cares nothing about where a person obtains practical knowledge, only he must have it to be a power in his profession.

We are constantly consulted by young engineers concerning the information that will best help them upwards in the business they follow. To such people we say: Acquire as much knowledge as you can concerning engineering matters. The engineer who makes one pound of coal do that for which two pounds were formerly consumed, is as much a public benefactor as the man who makes two blades of grass grow where one only grew.

#### Traveling Engineers' Convention Postponed.

Mr. W. O. Thompson, secretary of the Traveling Engineers' Association, announces that on account of the serious labor conditions that are now in progress, the Executive Committee has deemed it wise to postpone the annual convention which was to be held in the first week in September until a later date. The members will be advised as to when the new date of the meeting will be

# Air Brake Department

## Electric Operation of the New York P S Brake Equipment—Improving Train Stops Retarded Application Type of Distributing Valve—Collapsible Type of Equalizing Piston

### Electric Operation of the New York P S Brake Equipment.

In a previous issue we have explained the operation of the New York type P S triple valve and brake pipe vent valve when used pneumatically or when mixed in trains with any other types of triple valve or car brake operating valves, and at the present time we have an electro-type showing the valve with the electric portion added and the equipment in what is known as electric retain and release position. How the brake is electrically operated by the brake valve on the locomotive making the necessary contacts has also been explained, and it will only be necessary to point out that the same positions of the brake valve are used regardless as

the release magnet valve is normally open establishing a communication between the triple valve exhaust port and the atmosphere.

When the locomotive brake valve is in release position and main reservoir pressure is entering the brake pipe as explained in connection with the operation of the triple valve, the release magnet is energized and the magnet valve is held closed so that brake cylinder pressure cannot escape to the atmosphere although the auxiliary and supplementary reservoirs are being recharged for a subsequent brake application. When the brake valve is moved to running position the release magnet is de-energized and the magnet valve is open permitting an escape

the passage between the magnet valve and the check valve is removed, whereupon the brake pipe pressure would be exhausted to the atmosphere. In this manner the brake can be applied with any degree of severity desired and it follows that if for any reason whatever the electric current would be inoperative, the brake valve equalizing piston would lift and discharge brake pipe pressure in the usual manner. With the brake valve handle on lap position the reduction ceases and the brake is held applied.

When it is desired to graduate the escape of brake cylinder pressure or graduate the release of brakes the brake valve handle is moved to release and holding position as required to move the triple

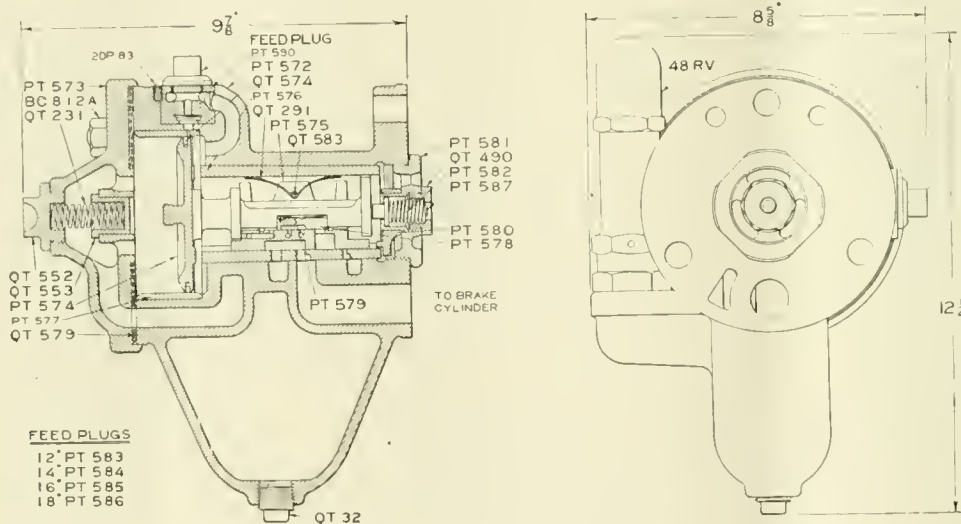

STYLE P S TRIPLE VALVE.

to whether the electric or the pneumatic features only are used.

When the simple devices for electric operation are bolted to the portion of the bracket provided for them and the various cars are connected through wiring and suitable jumper connections and the brake valve is provided with the electric contacts, the P S apparatus becomes an electro-pneumatic brake of the highest efficiency for stopping and controlling the speed of trains of any length or weight. All of the parts are simple, durable and easily maintained in proper working condition. The electric portion of the car equipment consists principally of three magnet valves known as release, service and emergency.

The service and emergency magnet valves are held to their seats normally by spring and brake pipe pressures, while

of brake cylinder pressure for the release of the brake. When the brake valve handle is in holding position the release magnet is again energized and the escape of brake cylinder pressure prevented while the brake pipe feed valve is controlling the pressure that is flowing to the reservoirs on the cars.

When a brake application is desired the brake valve handle is moved to service position and before the equalizing discharge valve of the brake valve can operate to discharge brake pipe pressure, each service magnet is energized and the magnet valve is opened and a brake pipe reduction is made at each P S brake equipment. A glance at the diagram will show that as the magnet valve opens, brake pipe pressure will be exhausted through valve 13 into a passage leading to the brake cylinder, unless the plug in

valve and recharge the auxiliary reservoir, while in these positions the brake cylinder exhaust port is closed by the release magnet valve. By alternating the brake valve handle between holding and running positions the brake can be released in any amount desired or graduated off at will—that is, in running position the release magnet is de-energized and in holding position it is energized, thus bringing the exhaust of the brake cylinder pressure on every car entirely under the control of the engineer.

When it is desired to apply the brake with its maximum effect in the shortest possible space of time or in case of emergency, the brake valve handle is moved to emergency position and the emergency magnets on each P S equipment are instantly energized and the brake pipe opened to the atmosphere. At this time



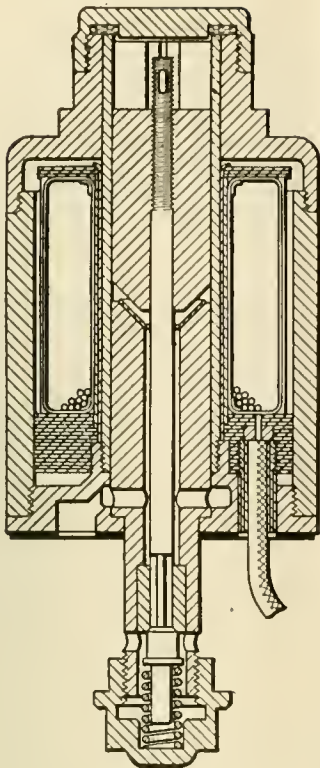

MAGNET VALVE.

the vent valves also operate, making a sudden heavy reduction of brake pipe pressure throughout the train, applying all brakes instantly while the auxiliary and supplementary reservoir pressures equalize with the brake cylinder, and this pressure is held throughout the stop, the safety valve being cut off from the brake cylinder during quick action applications.

**Improving Train Stops.**

We have been making an effort to emphasize the importance of a smooth train stop with the air brake and at the same time point out the difficulties encountered

in the way of adverse conditions both in freight and passenger service, that are beyond the possibility of a remedy so far as the actual brake manipulation is concerned. Attention has also been called to the practices of various railroads and what has been done in an effort to eliminate the rough handling of passenger trains with the air brake. This is undoubtedly the most difficult proposition that is confronting the railroad air brake man today, and one road in particular has gone so far as to forbid an engineer to make a brake application on a long passenger train with the engine throttle closed or rather have issued instructions that the brake application for ordinary stops must be made before the engine throttle is closed. They have also outlined the method of brake application that is to be employed, which specifies a 6 or 8-lb. brake pipe reduction as the initial, to be followed by another reduction calculated to bring the speed of the train down to twelve or fifteen miles per hour before the point of the desired stop is reached, when a release of brakes is to be made in such a manner that the brake valve handle is to be brought from release to running position for a sufficient length of time to partially release the engine brake and then pass on to service application position for the final light brake pipe reduction with which to make the stop. Such a method of brake application undoubtedly calls for an exercise of good judgment and skill on the part of the engineer if it is to be followed to the letter, however, it is being followed and very good results are being obtained in the way of making a smoother train stop.

The Pennsylvania Railroad, in spite of the great number of clasp type of foundation brake gear equipments in use on their passenger equipment cars, does not enjoy an entire, or the desired, freedom

from rough handling of passenger trains, and in an effort to remedy certain undesirable conditions are modifying the locomotive brake equipment to bring about a greater uniformity in operation between the car and locomotive brakes. Our readers will understand that the universal valve of the electro-pneumatic brake, or at present the U. C. equipment, which has been adopted as a standard by this railroad, will not apply with less than a definite or fixed amount of brake pipe reduction, which is usually from five to six pounds. The distributing valve of the locomotive is required to apply with a 5-lb. brake pipe reduction, and it frequently applies with somewhat less, with the result that the brake on the locomotive applies in advance of the car brakes. This produces a bunching of slack, then as the car brakes apply, the slack is again run out which sometimes produces disagreeable lurches, and, while it has not been a serious matter or resulted in enough rough handling to demand any drastic action, the company has decided to experiment with a modification of the distributing valve that will tend to produce a more uniform rate of retardation between the locomotive and car brakes throughout a stop.

The object has been to delay the application of the locomotive brake through a retarding of the application of the distributing valve. This has been done by adding a chamber in the form of a filling block between the distributing valve and reservoir and by drilling certain additional ports through the graduating valve, equalizing slide valve and slide valve seat of the distributing valve which will be explained under a separate heading.

At this same time it was considered advisable to decide upon some means for preventing the overcharge of the brake valve equalizing reservoir during a two-application stop. With ordinary type P

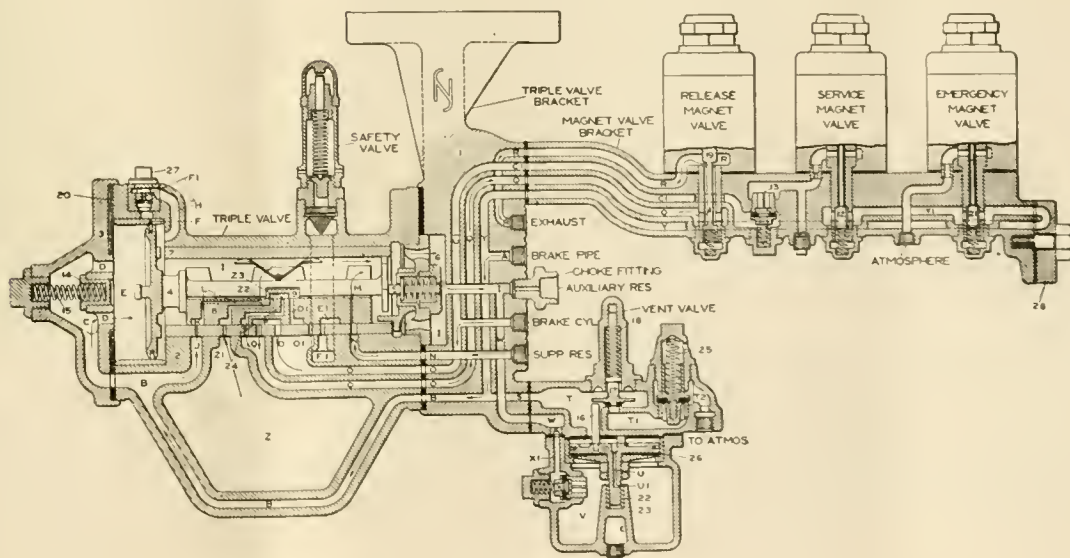

P S ELECTRO PNEUMATIC BRAKE, ELECTRIC RETAIN AND RELEASE.

and L triple valves and universal valves with the graduated release feature cut out, or, rather, whenever the graduated release is not in use, there are times where the two-application stop is advisable and will tend to produce smoother stops than can be made with a one-application stop. The cross compound air compressor which will give a very high brake pipe and equalizing reservoir pressure on the locomotive while the brake valve remains in release position during the release after the first application tends toward what is termed an overcharge of the equalizing reservoir, and with the usual neat fit of the equalizing piston and packing ring in the H-6 brake valve, this overcharge is retained with the brake valve on lap position while the brake pipe pressure reduces by flowing through the triple valve feed grooves and to the rear of the train where the brake pipe pressure is lower than on the head end.

As there is no practical way of preventing the higher pressure from entering the equalizing reservoir during the time the brake valve is in release position, and as it must be withdrawn from the equalizing reservoir through the preliminary exhaust port of the brake valve before a brake pipe reduction can be made for the second application of the two-application stop, and as considerable time is lost in making this reduction through a 1/16-in. exhaust port, it was decided to use an equalizing piston of the collapsible type which has found favor in electric service.

It will be understood that after the brake valve handle is brought from release to running position momentarily, and then to lap position, the equalizing reservoir pressure must be reduced below the pressure in the brake pipe, and, in turn, the brake pipe pressure must be reduced below that in the auxiliary reservoirs before a brake application can occur with the valve handle in service position, and during this time the tendency is for the train to pass the desired point of stop before the second application can be correctly made.

The results obtained with these two modifications during the tests were considered of sufficient importance to justify their adoption. The latter feature is, however, of a temporary nature because when the graduated release feature of the universal valves is in use there will be very little, if any, necessity for a two-application stop, and when the electric portions are added to the universal valves now in use and the electro-pneumatic brake is in operation, there will be no need for an equalizing piston in the brake valve, unless the electric current fails, as each universal valve will be relied upon to make the brake pipe reduction instead of the locomotive brake valve.

### Retarded Application Type of Distributing Valve.

Requests have been made for literature describing the retarded application type of distributing valve and the collapsible type of equalizing piston brake valves as applied to certain Pennsylvania Railroad locomotives.

There is no description of these devices in print, for the reason that the apparatus is still in an experimental stage and is subject to further modification; if it fails to manifest the improvement desired it may be dispensed with, and if adopted as a standard the distributing valve reservoir will probably be changed to a three compartment reservoir, and, moreover, the intent of the modification is so obvious and the manner in which the retardation of the driver brake is accomplished is so simple as to require no detailed description or diagrammatic views for an air brake inspector or repairman to understand the operation of either of the features.

The distributing valve has been modified to the intent that the application of the locomotive brakes may be retarded to such an extent that they will apply more uniformly with the universal valves of the passenger car brake equipments, which will not apply with less than a definite (five or six pounds) brake pipe reduction, this delayed application or failure to apply on light variations in brake pipe pressure being one of the chief improvements sought in the design of the universal valve.

The retarded application of the locomotive brake is accomplished by adding a reservoir or chamber in the filling block placed between the distributing valve and the distributing valve reservoir, and by drilling an additional port opening through the equalizing slide valve graduating valve, the equalizing slide valve and the equalizing slide valve seat leading to the filling block chamber and by another port leading from the slide valve seat to a separate exhaust port to the atmosphere.

When the brake valve handle is placed in service position, or at any time the brake pipe pressure falls at a faster rate than at which the pressure chamber pressure can keep equal with the brake pipe by flowing backward through the feed groove in the equalizing piston bushing, the differential in brake pipe and pressure chamber pressure thus created moves the equalizing piston and graduating valve in the usual manner, the piston severing communication between the two pressures by closing the feed groove while the service port in the equalizing slide valve is opened, but at the same time the added port previously mentioned is opened from the pressure chamber through the equal-

izing slide valve and seat to the chamber in the filling block and pressure chamber air expands into the filling block at the same rate that brake pipe pressure is reducing. Therefore, the differential in pressure necessary to move the equalizing slide valve to service or application position cannot be obtained until after the pressure chamber equalizes with the filling block.

The size of the filling block chamber is so proportioned to the size of the pressure chamber that with 110 lbs. pressure in the pressure chamber they will equalize at 105 lbs. pressure. Thus it will be readily understood that the first five pounds brake pipe reduction will be wasted or have no effect on the application of the brake, but thereafter a further reduction in brake pipe pressure will result in the pressure chamber remaining higher, as it can no longer escape into the filling block chamber, and the differential in pressure necessary for the equalizing piston to move the slide valve will be obtained in the usual manner. Therefore, as a result of this modification, the locomotive brake will not apply with less than an 8 or 10-lb. brake pipe reduction, and as the equalizing slide valve moves to service position the pressure chamber is cut off from the filling block and the same movement opens the filling block chamber through the equalizing slide valve seat and a separate exhaust port to the atmosphere, emptying the filling block chamber.

One of these distributing valves can be distinguished by the separate exhaust port at the outside of the equalizing slide valve bushing, near the safety valve connection, into which a 3/8-in. service elbow is screwed.

### Collapsible Type of Equalizing Piston.

The collapsible type of brake valve equalizing piston, which has been used in electric service for a number of years, gives identically the same operation as the solid type of piston with the exception that it will not permit the equalizing reservoir pressure to become more than 2 lbs. higher than the pressure that may be in the brake pipe.

So far as the air brake inspection is concerned no difference in operation can be noticed; the same standard brake valve test applies regardless as to whether the equalizing discharge valve is collapsible or solid, but the collapsible piston is designed for use during brake operation with a train of cars, notably during a two application stop with a passenger train. At such times a release after the first application results in a very much higher pressure in the brake pipe at the head end of the train and in the equalizing reservoir; that is, a higher pressure temporarily, especially with the cross-compound air compressor, and when the brake valve

handle is brought to lap position preparatory to the final application, the triple valves and universal valves are in release position and the auxiliary reservoirs are absorbing pressure from the brake pipe. Consequently, brake pipe pressure is lowering while the equalizing reservoir pressure remains stationary or, at least, falls no faster than at the rate at which it can leak past the equalizing piston packing ring into the brake pipe. Therefore, it follows that when brake valve handle is placed in service position, the equalizing reservoir pressure must be reduced below the pressure in the brake pipe, or rather that remaining in the brake pipe, before a difference in pressure necessary to unseat the equalizing piston and discharge brake pipe pressure can be obtained.

It naturally follows that an 8 or 10-lb. higher pressure in the equalizing reservoir will consume approximately 3 or 4 seconds' time in which to obtain an action of the equalizing piston. Therefore, the collapsible piston is relied upon to eliminate a portion of this time element by keeping the brake pipe and equalizing reservoir pressure within 2 lbs. of each other.

This is accomplished by making the piston and the stem in two separate portions so constructed that a spring is used between them and a series of grooves are cut in the equalizing piston bushing below the packing ring when the valve is in normal position. The tension of the spring is proportioned to the area of the piston so that a difference of 2 lbs. pressure will cause the equalizing piston to "collapse" and discharge the higher equalizing reservoir pressure into the brake pipe. The equalizing reservoir pressure, under this condition, is discharged through the series of grooves in the bottom of the equalizing piston bushing, which are cleared by the piston packing ring when the piston collapses, and as soon as the pressures are approximately equalized, the spring between the piston and stem extends and the structure assumes its normal position.

The brake valves containing this type of piston have the letters C P stencilled on the outside of the lower case of the brake valve below the number plate on the rotary valve body.

If the identification marks are missing or if there is any doubt as to which type of piston is embodied in the brake valve, it may be ascertained without taking the brake valve apart by having the pressure on the engine pumped up and placing the brake valve handle on lap position and opening one of the brake pipe cocks at the rear of the tender or the front of the engine, and noting the drop of the equalizing reservoir gage hand. If the brake valve has the standard solid piston, the drop of the hand will be very slow; that is, merely as fast as the equalizing reservoir pressure leaks past the equalizing piston packing ring into the brake

pipe; whereas, if the piston is of the collapsible type, the drop in equalizing reservoir pressure will be prompt, exhausting almost as fast as the brake pipe pressure drops.

There is a possibility of one of these pistons becoming defective through a broken spring, or by the piston remaining stuck together or collapsed by an operation, and if it occurs the equalizing piston is not likely to lift or discharge brake pipe pressure during a service application and the action of the valve would be similar to that of one with a stuck equalizing piston or a broken body gasket, and if such a valve is found it will only be necessary for the inspector to report the action of the brake valve.

#### Sleeping Cars Sixty-five Years Ago.

Writing from New Haven, Conn., in August, 1859, Charles Hallock, then editor of *Forest and Stream*, describes in his paper a trip over the Erie made in that year. The Erie was the first railroad in this country to run sleeping and parlor cars over its lines—one of the many innovations it established for the betterment of railroad travel. This was Mr. Hallock's first experience in a sleeping car, for, he writes in a personal letter, "Four years earlier I went up the Erie road on my wedding trip to Niagara Falls. There were no sleepers then, and we sat up all night in upholstered seats which had comfortable rests for the head, protected by linen covers which were changed as soon as soiled."

Of that first experience in a sleeper, Mr. Hallock wrote:

"On arriving at Dunkirk, we boarded the Night Express, and took our seats in the luxuriantly furnished sleeping cars, determining to try the virtue of this boasted institution. Lodgings were furnished at 50 cents a head. My little girl, who accompanied me, was stowed in without extra charge. There were 40 berths in the car, four in each tier, one double berth at the bottom and two above. The upper berths were cane frames, the ends of which were fixed into sockets, while the bottoms of the lower were of wood. All were covered with nice hair mattresses, and pillows enclosed by damask curtains, making a very handsome appearance. About nine o'clock the chambermaid, who was a buxom round-faced laddie, made up the berths and we turned in. There were about thirty sleepers in all.

"The cooler of ice water is a grand luxury amid the dust, dirt and heat of an August ride. We resorted to it 20 times, I presume, in the course of the trip. I go for the sleeping car for its day conveniences, as well as its night comforts, its select companies, its well-furnished and home-like appearance. I think the railroad lets out these sleeping cars to be furnished and run by others. It was managed by a distinct person, who had

his runners through the cars, and at every station crying up the virtues of the institution. 'Here is your fine sleeping car, only fifty cents; plenty of berths, a good night's rest warranted; towels and water in the morning; no waking up for tickets; crying children excluded; tumble in, gentlemen and ladies.' On the whole the sleeping car is the best one to ride in, either day or night."

#### Good Use for a Water Glass.

An old time engineer who had pulled throttles when the Union Pacific Railroad was under construction waxed reminiscent at the finish of the railroad club meeting.

After some preliminary talk mostly about the dangerous Red Skins, he went on. "One day I got a new Baldwin and started for the front. I had never been out of sight of civilization before, so all the Injun stories I ever heard, came crowding upon my memory.

"All day I was on the lookout for red, blue and green blankets, to say nothing of skulking red skins. We had a train of material for the front and would get there for breakfast, if we hustled—so I hustled.

"About eleven o'clock, I stopped at a temporary water station to liquidate and lubricate. While the fireman was taking water I oiled around. That duty finished, I climbed to the gangway and was about to blow out the torch when my heart closed my mouth, for there stood a big, fat, greasy Injun. He had on a red blanket, had a rifle in his hand and greeted me with a grunt.

"The conversation that followed was brief.

"'Get off,' says I.

"'No get,' says the Injun.

"The long spouted oil can was in my hand and I aimed for the water-glass, which was near the visitor's face, with good results. The cab was like a roaring volcano, but the Red Skin had disappeared."

#### Effect on Steel of Alloys.

An impression has long prevailed among iron workers that pure iron is a much more valuable material than iron containing impurities, yet it is every day becoming apparent that certain impurities make a much stronger steel than the ordinary mixture of iron and carbon.

There was nothing in use approaching in strength and durability the high speed tool steel, so common today, until metallurgists learned the art of mixing the impurity tungsten as an alloy of iron. There are other impurities that exert a beneficial influence on steel. Titanium acts on molten steel mixtures as an effective scavenger of undesirable elements, and molybdenum imparts toughness to steel making it particularly valuable for many purposes.

# Sizes of Valves in Modern Existing Locomotives

In the report of the committee on modernizing existing locomotives, at the recent meeting of the American Railway Master Mechanics' Association, an interesting section was devoted to the question of the sizes of locomotive valves, the opinion of the committee being that, with superheated steam, it is possible to use a smaller diameter of piston valve for the same size of cylinders than would be necessary for saturated steam. This is largely on account of the lightness of the superheated steam, which permits it to traverse the passages and ports at a much higher velocity.

The sizes of piston valves used by a prominent locomotive builder in this country are as follows:

motives using superheated steam. The conclusion drawn from these tests led the Pennsylvania Railroad to adopt 12 inch diameter of valves for cylinders between 20 and 27 inches in diameter, and for cylinders 20 inches and less, 8-inch diameter valves.

The results of these tests were published in P. R. R. Test Department Bulletin No. 23, 1914. Some of the conclusions drawn from these tests, printed on pages 31 and 32, are as follows:

"To establish a relation between the valve and cylinder so that the valve may be standardized, it may be stated generally that the diameter of the valve in inches for superheated steam should not be less than  $0.016D^2$  where  $D$  = the

a railroad to carry in stock as few diameters of piston valves as possible. These considerations doubtless led the Pennsylvania Railroad to adopt the 8 and 12-inch valves as standard to be used in new construction and reconstruction wherever possible.

These sizes adopted by the Pennsylvania Railroad are so much smaller than required by current locomotive practice in the United States that some caution should be observed in adopting them without due consideration. For instance, the statement in the last paragraph of the conclusion, namely, calling attention to the necessity of an increase in percentage of cut-off with the smaller valve diameter in order to obtain the same

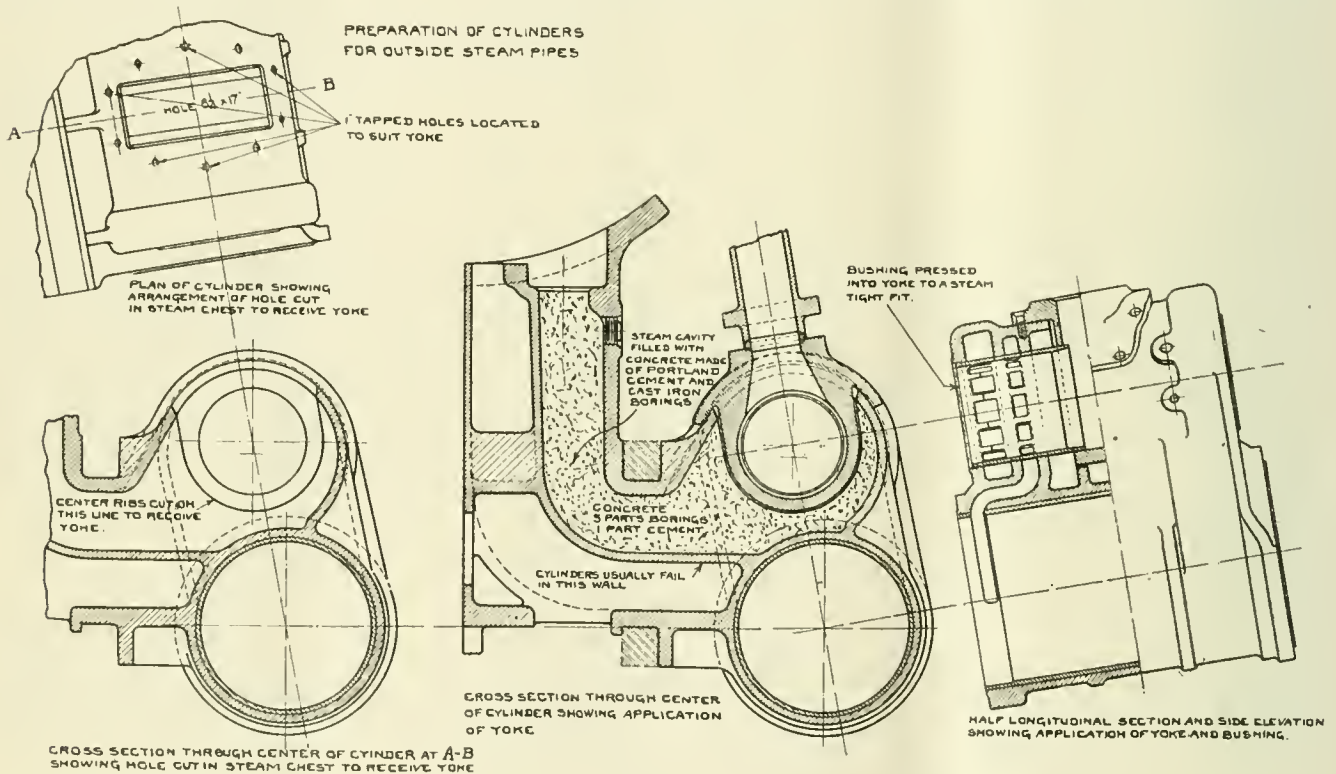

APPLYING OUTSIDE STEAM PIPES TO PISTON VALVE CYLINDERS ON THE SOUTHERN PACIFIC.

Valve Diameter.	Cylinder Diameter.	
	Saturated Steam.	Superheated Steam.
19 in.	17 in. to 18 in.	18 in. to 19 in.
11 in.	18½ in. to 20 in.	19½ in. to 21 in.
12 in.	20½ in. to 22 in.	21½ in. to 23 in.
14 in.	22½ in. to 24 in.	23½ in. to 27 in.
16 in.	24½ in. upward	27½ in. upward

Extensive tests were made by the Pennsylvania Railroad on the locomotive testing plant at Altoona to determine the limitations in the use of piston valves varying from 7 to 16 inches in diameter, on locomotives having 22, 24 and 25 inches diameter of cylinders. In all cases these tests were made with loco-

diameter of cylinder in inches. The 12-inch valve is now used for cylinders between 20 and 27 inches in diameter, while for cylinders of 20 inches or less an 8-inch valve is used. Cylinders above 27 inches diameter have not been used for any class of locomotive of which there is more than one example, and a valve diameter for such cylinders need not be considered at present.

"Decreasing the valve diameter on a locomotive necessitates increasing the percentage of cut-off to obtain the same power at the same speed. This causes a longer valve travel."

From a maintenance point of view, it is of course desirable and economical for power at the same speed, is significant,

since it necessarily follows that the expansive force of the steam is not utilized as advantageously, and it would therefore appear that some decrease in economy would result.

The question of size of piston valves is of interest in the modernizing of existing locomotives, since many railroads were committed to the use of slide valves because of their many recognized good qualities. With the general introduction of the superheater, and its recognized necessity for modern engines, difficulty was experienced in applying superheaters to engines equipped with slide valves, because a film of oil could not be maintained by ordinary methods of lubrication between the valve and its seat, and to

the deformation of the valve and its seat at the higher temperatures.

A steam chest containing a piston valve that can be applied to existing slide-valve cylinders has been designed, manufactured and tried on many leading railroads. At the present time it is estimated that upward of 75 engines having slide-valve cylinders are equipped with superheaters, these steam chests and piston valves. The sizes of piston valves which have been used for this purpose are 8 inches in diameter, with ports up to and including 19 inches in length; 9 inches in diameter, with ports 20 to 22 inches in length, and 10 inches in diameter, with ports exceeding 22 inches in length.

A novel method of applying outside steam pipes to piston-valve cylinders, used by the Southern Pacific Railway Company at their Los Angeles shops, is shown in the accompanying drawing. This consists of cutting a hole  $8\frac{1}{4}$  by 17 inches in the upper wall of the steam chest, and dropping therein an integral finger-ring bushing fitted and bolted to place, and afterward bored out for the bushings. It will be noticed that the only steam tight joint necessary for the finger-ring casting is where the bushings are pressed in. The fitting between the finger-ring bushing and the outside wall of the steam chest need not be steam tight; only a solid bearing for bolting is required. The details and drawing were furnished by Mr. T. W. Heintzelman, general superintendent of motive power of the road. Other methods for the same purpose are used on other roads.

#### A Mechanic Bests a Lawyer.

A mechanic very rarely gets the best of a lawyer in a business transaction, but it occasionally happens that the man of the file gets the better of the man of the pen. The story is a little old, of how W. A. Simpson, of Cedar Rapids, met a court judge one day and in the course of conversation happened to ask the man of law a question about some subject they were discussing without any idea of seeking professional advice. Soon afterward Mr. Simpson received a bill from the judge of one thousand dollars for legal advice. The bill was paid without complaint.

Time passed on and one day the judge, who was heavily interested in hog packing operations, needed some mechanical advice about some machines that were not working properly. He asked Mr. Simpson to examine the machines and tell him what was wrong. This service Mr. Simpson performed and indicated the cause of the trouble. When he went home he promptly made out a bill against the judge for fifteen hundred dollars. The bill was duly paid and the people of Cedar Rapids joked about the case as the first time a mechanic got the best of a lawyer.

## Heat, Motion and Work, and Their Units of Measurement. Second Paper

### UNITS OF MEASUREMENT.

Thus, for linear measurement we have the inch, and instead of saying a thing is as long as a stick, we say it is so many inches long; or a thing isn't as heavy as a stone; it weighs so many pounds. So when the mechanical theory of heat was accepted, it was necessary to establish a unit by the use of which quantities of heat could be measured. The thermometer measures the quality—that is, the intensity of the heat—but not the quantity. Here again, water is the best medium, and the

### UNIT OF HEAT

was fixed as the quantity of heat that will increase the temperature of one pound of water by one degree, the water being at a temperature just above freezing. The reason why the temperature of the water is fixed—Rankine makes it 39.1 degs.—is because the quantity of heat varies slightly at different temperatures. But the variation is so slight as under ordinary circumstances to be of little importance. The most we care for now is to understand what a unit of heat really is. A pound of water is a definite—a measurable quantity—so is a degree on the Fahrenheit scale; then, although we cannot handle a unit of heat, it is still, by comparison, a definite quantity.

### THE UNIT OF WORK.

The unit of work is the foot-pound; it is the amount—the quantity—of work required to lift a weight of one pound to a height of one foot against the force of gravity. This unit is used to measure motion in any direction against resistance. Now it will be readily understood that, to make the knowledge of heat readily available for calculations, it was necessary to establish the exact relation between the unit of heat and the unit of work, and after much experiment it was found that one unit of heat was equal to 778 units of work.

That is something worth while thinking about. We can afford to give it a little more attention, even at the expense of recapitulation; let us do so. A unit of heat is the quantity of heat required to raise the temperature of one pound of water one degree. By comparison we can get a fair idea of this quantity without being able to see it. A pound of water is—near enough for present purposes—one pint; not a very large quantity. And a difference in temperature of one degree in this water is not appreciable to the touch. If you took this pint of water at a temperature of 39 degs., you could hardly put your hand in it and remove it without increasing its temperature by one degree. Put the water

in a tin basin and burn a match under it, and you might increase its temperature one degree. A pound of coal is a small lump, yet it is capable of yielding from 12,000 to 14,000 units of heat. From the foregoing we can see that a unit of heat is a very small quantity indeed. Yet if all this heat was usefully expanded in doing work it would raise a weight of one pound to a height of 778 feet, or a weight of 778 pounds to a height of one foot. This 778-foot pounds is called the mechanical equivalent of heat. What this really means is that one unit of heat will perform 778 units of work.

### ENERGY.

Energy, in mechanics, is the capacity for doing work, and is usually considered as divided into two kinds, viz.: Kinetic, or actual energy, and potential, or possible energy. If a body is moving at a given velocity, it possesses actual energy, and the amount of this may be determined by a consideration of its weight and velocity. For example, a cannon ball of a given weight projected at a given velocity, possesses a definite amount of actual energy, because it will do a definite amount of work in being brought to rest. The fly-wheel of a steam engine contains actual energy because it will do work in being stopped, or in having its motion reduced.

Potential energy is the possibility of doing work possessed by a body. Thus, if the same cannon ball were carried from the ground to the top of a building, it would possess potential energy with reference to the ground, because it would do work in falling.

### ENERGY OF COAL.

Coal, which is the most common fuel in use, possesses the possibility of heat, and heat is motion of one kind. According to strict definition it would not, perhaps, be correct to say that coal possessed potential energy; still, if one were to say this were so, it would not be easy to successfully dispute the statement. To return to the cannon ball, its potential energy is due to the fact that it has been carried away from the ground; in carrying it away work has been done, and, of course, heat has been expended. When we let it fall it will render an exact equivalent for the work done in raising it. The cannon ball lies inert at the top of the building, but if we release it, it falls to the ground, and in falling does the work that has been done in raising it.

Now take a lump of coal weighing, say, one pound. It is before us inert, but, like the cannon ball at the top of the building, it possesses the possibility of producing heat, which heat may in turn be converted into motion against resistance. The action of the sun—the heat—has gone

on for years storing up possibility of energy in this lump of coal; carrying the cannon ball to the top of the building stored up the possibility of energy in it.

#### COMBUSTION.

We liberate the heat stored up in the coal by combustion, which is a chemical combination productive of heat. There is a material difference between a chemical combination of substances and a simple mechanical mixture of substances. Thus the two gases, oxygen and nitrogen, unite, mechanically, to form air, and in air we find without difficulty the properties pertaining to both these gases. Substances unite chemically when they have affinity—that is, chemical attraction—one for the other, and the result is a compound entirely unlike either of the substances, entering into the combination. Certain substances, each harmless in itself, may chemically combine to form a high explosive or a deadly poison.

In all chemical combinations heat is evolved, but the combination may be so slow that the heat is not noticeable. But in combustion, as we speak of it in burning coal, the combination is rapid, and the heat evolved is correspondingly intense. This combination is that of oxygen and the combustible matter of the coal, which is largely carbon. The heat resulting from the combustion is believed to be due to the violent clashing together of the atoms of the combustible matter and the atoms of oxygen, in their intense efforts to unite.

The chief constituents of coal are carbon and hydrogen. What is called a pure anthracite coal contains about 92 per cent. carbon, 2 per cent. hydrogen, 1 per cent. oxygen, 2 per cent. water and 3 per cent. ash; and, since carbon predominates—in fact forms nearly all the combustible in the coal—we may for present purposes consider all the combustible matter as carbon. It has been experimentally determined that the combustion of a pound of pure carbon will yield 14,500 heat units, and as the combustion of hydrogen, weight for weight, yields rather more than four and a fourth times as much heat as the combustion of carbon, we may conclude that a pound of the purest obtainable anthracite coal will yield 14,500 heat units. Let us put it at 14,000. The problem that concerns you as engineers and firemen is how to set this heat free, and how best to utilize it in moving the piston of the engine back and forth in its travel.

It will be interesting to think of the equivalent in mechanical work of this little lump of coal. It contains 14,000 heat units, each equivalent to 778 units of work, altogether  $14,000 \times 778 = 10,892,000$  feet, that the heat of this small piece of coal would lift a weight equal to its own if all the heat it contained could be applied to that purpose; this is

more than 2,000 miles. It seems almost incredible, yet it is no more than the realization of the full mechanical equivalent of the heat in the coal.

Let us see what work we get from this coal in actual practice. In steam plants as they go, and in every-day practice, if we get a horse-power on the consumption of two and a half pounds of coal per hour, the result is considered very good. Some plants may be doing as well as this, but very few better, and many worse. Now let us take this same one pound weight and use an engine requiring two and a half pounds of coal per horse-power per hour to raising it to a height of 2,000 miles, or equivalent work. Suppose we raise this weight to a height of 2,000 miles in one hour of time. A horse-power will raise 33,000 pounds one foot high in one minute, so it will raise 1,980,000 in one hour. Dividing 10,808,000—the number of feet in 2,000 miles—by this, shows us that it would require  $5\frac{1}{2}$  horse-power exerted for one hour to raise this pound weight to a height of 2,000 miles. At two and a half pounds of coal per horse-power there would be required  $13\frac{3}{4}$  pounds of coal to do what work there is heat enough in one pound to do. In this instance, viz., with an engine using two and a half pounds of coal per horse-power per hour, between 7 and 8 per cent. of the total heat efficiency of the coal is utilized. It will readily be understood that with the largest and most efficient of steam engines—those doing a horse-power on about one and a quarter pounds of coal—the greater part of the heat goes to waste.

#### HOW LOSSES OCCUR.

In order to save it is necessary to consider how losses occur. Let us start first at the boiler. Combustion, as we have seen, is a chemical combination of combustible matter and oxygen. In chemical combinations definite quantities unite. If too much of one substance is present the surplus is rejected. In the combination of carbon and oxygen, called combustion, one pound of carbon unites with two and two-thirds pound of oxygen, the result being carbonic-acid gas. Air is composed of the two gases, oxygen and nitrogen, nitrogen largely predominating, so that, to get the two and two-thirds pounds of oxygen required, we must have about 12 pounds of air. This is assuming that all the oxygen is utilized. In practice this is not the case, so that it is necessary to supply about 24 pounds of air to the furnace for every pound of coal burned. Not only is the oxygen we use largely diluted with the nitrogen, that is of no use in supporting combustion, but we admit about twice as much air as we use the oxygen from. The nitrogen is inert, but its presence is necessary to dilute the oxygen. We know that the gases as they enter the chimney are hot, as we

use the term, and that all the heat they carry away to the chimney must come from the coal. Hence we can readily see that all this surplus air that goes through the furnace, and the nitrogen of the air from which the oxygen has been used, carry away part of the heat of the coal, heat we are trying to utilize as motive power. There is loss here—in part necessary loss, and generally in part unnecessary loss. Let us see what this loss is.

#### Workman's Evening School of Long Ago.

When Angus Sinclair, Ia., he helped to organize and keep in operation an evening school for the instruction of workmen employed in the repair shops of the Burlington, Cedar Rapids & Northern Railway.

The Cedar Rapids *Republican* commenting upon the work done in this school said:

"Mr. Sinclair's first aim was to give instruction in mechanical mensuration, as he considered the students could thereby acquire intimate acquaintance with the calculations their work brought them into daily contact with. As nearly all mechanical calculations require the use of decimals and the roots he pushed them on with these branches of arithmetic. Then they proceeded to the calculating of various kinds of figures, acquiring the commonest rules of procedure. The dimensions of water tanks and of air brake reservoirs under construction in the shops were figured out and formed good examples for men to calculate their carrying capacity or cubic contents. Then fire boxes and flues were measured, and the heating surfaces and grate areas of locomotive boilers were reckoned up. From these particulars it was an easy step to calculating the horsepower of engines of various dimensions and the traction power of the locomotives pulling trains on the road. Then they proceeded to the study of statics, devoting particular attention to the sections which applied more directly to their work. The lever, with all its ramifications which brought in methods of transmitting power by all processes of wheels, pulleys and screws, received laborious attention, and those who attended the classes regularly became expert in figuring out power and speed under a wide variety of conditions. Thermodynamics was entered upon and the students promise to attack those principles of heat-force during the coming season. Most of them have got far enough along to realize that every step in the progress of learning opens out new fields of study that they desire to enter upon."

That was written in 1883, the year Dr. Sinclair left railway service. The school ceased to be operated then, but it helped quite a number of the workmen to rise in their business.

# Narrow Gauge Locomotive for the East Broad Top Railroad and Coal Company

Owing to the limited amount of narrow-gauge mileage in the United States, it is comparatively seldom that locomotives of special interest are built to a gauge other than the standard. An exception may be noted, however, in the case of a locomotive recently built by the Baldwin Locomotive Works for the East Broad Top R. R. and Coal Co. This is a 3 ft. 0 in. gauge engine of the Mikado type. It exerts a tractive force of 30,000 pounds, and the weight on driving-wheels is 130,900 pounds. The road has grades of  $2\frac{1}{2}$  per cent. and is laid with 60-lb. rails; there are curves of 17 degrees on the main line, and of 23 degrees in yards. The second and third pairs of driving-wheels have plain tires, to facilitate traversing these curves.

The boiler has a straight top, and is

The main frames are placed between the wheels, with their centers 25 inches apart. Owing to restricted space, the width of the frames is made only 4 inches and the length of the driving-journals 8 inches. The frame rails, however, are of liberal section, the upper rail being 6 inches deep and the lower rail 5 inches. The rear truck is of the Rushton type with outside journals, and the rear frames are outside the wheels. A strong cast steel brace, which is placed at the back end of the main frames, is extended in width on each side so that the rear frames can be bolted to it. This brace also serves as a support for the forward end of the firebox. In addition to the crossties which brace the upper frame rails, a vertical cast steel tie is placed at each pair of driving pedestals.

Cylinders—20 x 24 ins.

Valves—Piston,  $9\frac{1}{2}$  ins. diam.

Boiler—Type, straight; diam., 66 ins.; thickness of sheets,  $\frac{7}{8}$  in.; working pressure, 180 lbs.; fuel, soft coal; staying, radial.

Fire box—Material, steel; length, 101  $\frac{11}{16}$  ins.; width, 60 ins.; depth, front  $62\frac{1}{4}$  ins., back  $51\frac{1}{2}$  ins.; thickness of sheets, sides  $\frac{5}{16}$  in., back  $\frac{5}{16}$  in., crown  $\frac{3}{8}$  in., tube  $\frac{1}{2}$  in.

Water space—Front,  $3\frac{1}{2}$  ins.; sides, 3 ins.; back, 3 ins.

Tubes—Diam.,  $5\frac{3}{8}$  ins. and 2 ins.; material, steel; thickness,  $5\frac{3}{8}$  ins. No. 9 W. G., 2 ins. No. 11 W. G.; number  $5\frac{3}{8}$  ins. 22, 2, 147; length, 17 ft. 6 ins.

Heating surface—Fire box, 141 sq. ft.; tubes, 1,879 sq. ft.; total, 2,020 sq. ft.;

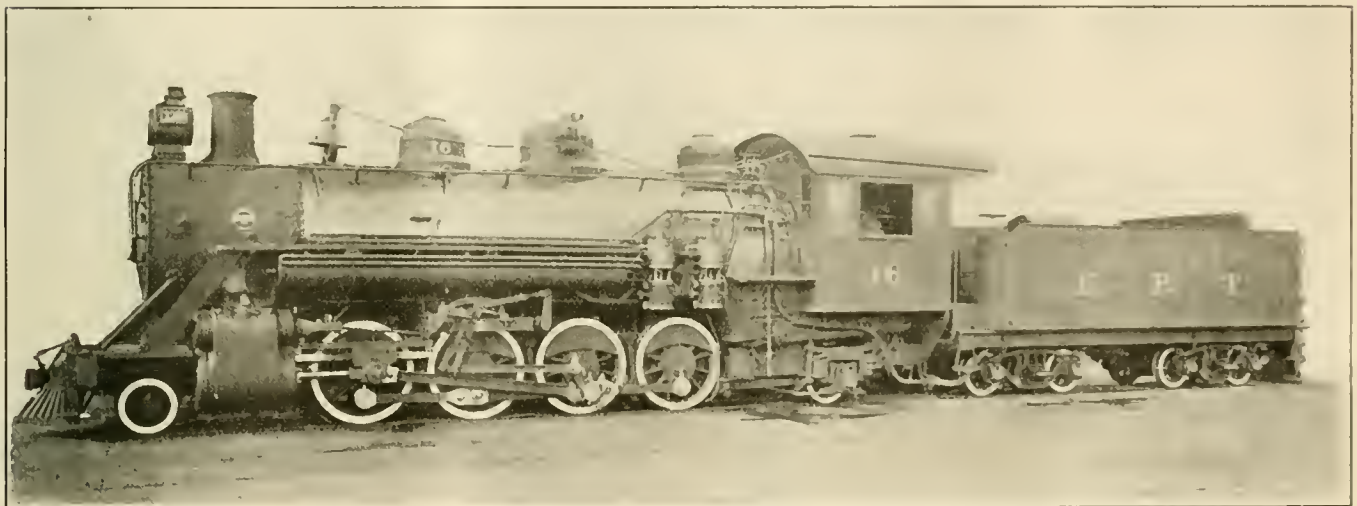

NARROW GAUGE 2-8-2 TYPE LOCOMOTIVE FOR THE EAST BROAD TOP RAILROAD AND COAL COMPANY

Baldwin Locomotive Works, Builders.

66 inches in diameter at the front ring. It contains a Schmidt superheater of 22 elements, and has a wide firebox, with a throat  $17\frac{3}{4}$  inches deep. The front end of the crown is supported on two rows of Baldwin expansion stays, and 401 flexible bolts are used in the water legs. These stay the entire throat, and the remainder are located in the three top and bottom horizontal rows, and the three front and back vertical rows in the sides. The throttle is of the improved Rushton type, with drifting valve. In service, the safety-valves are set at 180 pounds, but the boiler and machinery are built for 200 pounds. The steam distribution is controlled by  $9\frac{1}{2}$ -inch piston valves, which are operated by the Southern valve gear. The Ragounet power reverse mechanism is applied.

The arrangement of the driver brakes on this locomotive deserve mention. The space between the frames is too narrow to permit placing the cylinders side by side, hence the brake is divided, one cylinder operating the shoes on the first and second pairs of wheels, and a second cylinder operating those on the third and fourth pairs. The shoes bear on the backs of the wheels in each case. The front cylinder is placed in a vertical position and is supported on the guide yoke, while the back cylinder is supported, in a horizontal position, above the second driving axle. Combined automatic and straight air equipment is applied.

The following are the principal dimensions of this narrow gauge type of locomotive:

Gauge—3 ft.

superheater, 465 sq. ft.; grate area, 42.5 sq. ft.

Driving wheels—Diam., outside 48 in., center 42 ins.; journals, main,  $8\frac{1}{2}$  x 8 ins.

Engine truck wheels—Diam., front 24 ins.; journals, 4 x 7 ins.; diam., back, 26 ins.; journals, 5 x 9 ins.

Wheel base—13 ft. 6 ins.; rigid, 13 ft. 6 ins.; total engine, 28 ft. 8 in.; total engine and tender, 54 ft. 8 ins.

Weight—On driving wheels, 130,900 lbs.; on truck, front 10,800 lbs., back 18,800 lbs.; total engine, 160,500 lbs.; total engine and tender, about 240,000 lbs.

Tender—Wheels, number, 8; diam., 26 ins.; journals,  $4\frac{1}{4}$  x 8 ins.; tank capacity, 4,000 gals.; fuel capacity, 7 tons; service, freight.

# Electrical Department

## Catechism of the Electric Locomotive Continued

We have traced the electric current in the case of the direct current system from the third rail shoes to the main switch

A. Power is taken from an independent source, a storage battery being furnished for this purpose.

A. Usually a storage battery of from 22 to 32 volts is used.

Q. What is the general arrangement of the control circuits?

A. The battery power is connected to a piece of apparatus known as the master controller. This master controller is located adjacent to the air brake valves and provides the means for connecting the battery current to a system of control wires which run from the master controller to the unit switches. The energizing of a control wire operates a small air valve allowing the air pressure to enter a cylinder moving the piston and thereby closing the switch. The power from the main circuit is connected to the switch so that the closing of the switch throws the power on to the motors. These unit switches are grouped together in numbers varying anywhere from 6 to 12 or even more. The group of switches is called a "switch group." Fig. 11 shows a switch group made up of 11 switches. Each of these 11 switches is a unit and is interchangeable.

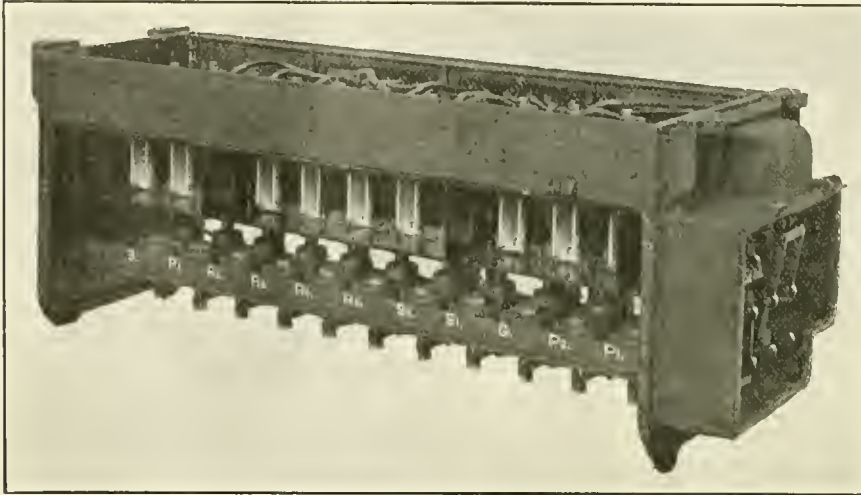

FIG. 11. SWITCH GROUP COMPOSED OF ELEVEN ELECTRO-PNEUMATIC UNITS.

and in the case of the alternating current system from the overhead trolley wire through the oil circuit breaker and the transformer. Apparatus is necessary to connect this current to the motors and to provide a means for connecting the motors in the proper combinations for operation forward and backward at different speeds. It is designated as control apparatus and the following questions will not only cover the connections and arrangement of this control apparatus, but will cover the construction.

Q. What is the voltage of the storage battery?

There are two distinct systems which have been used to date:

1. The electro-pneumatic system.
2. The electro-magnetic system.

The electro-pneumatic system has been developed by the Westinghouse Electric Company and has been used extensively in the locomotives built by them. This system is in use on all of the locomotives on the N. Y., N. H. & H. R. R., Penn. R. R., Norfolk & Western Railroad and many others and the details of this system will be discussed first.

*Westinghouse Electro-Pneumatic System.*

Q. What is the principle used in the operation of the above system?

A. Air which is available on the locomotives is used as the power for closing contacts or switches which, in turn, connect the electric power to the motors.

Q. How is the operation of these switches controlled?

A. The switches are controlled by means of circuits known as control circuits.

Q. What power is supplied to the control circuits?

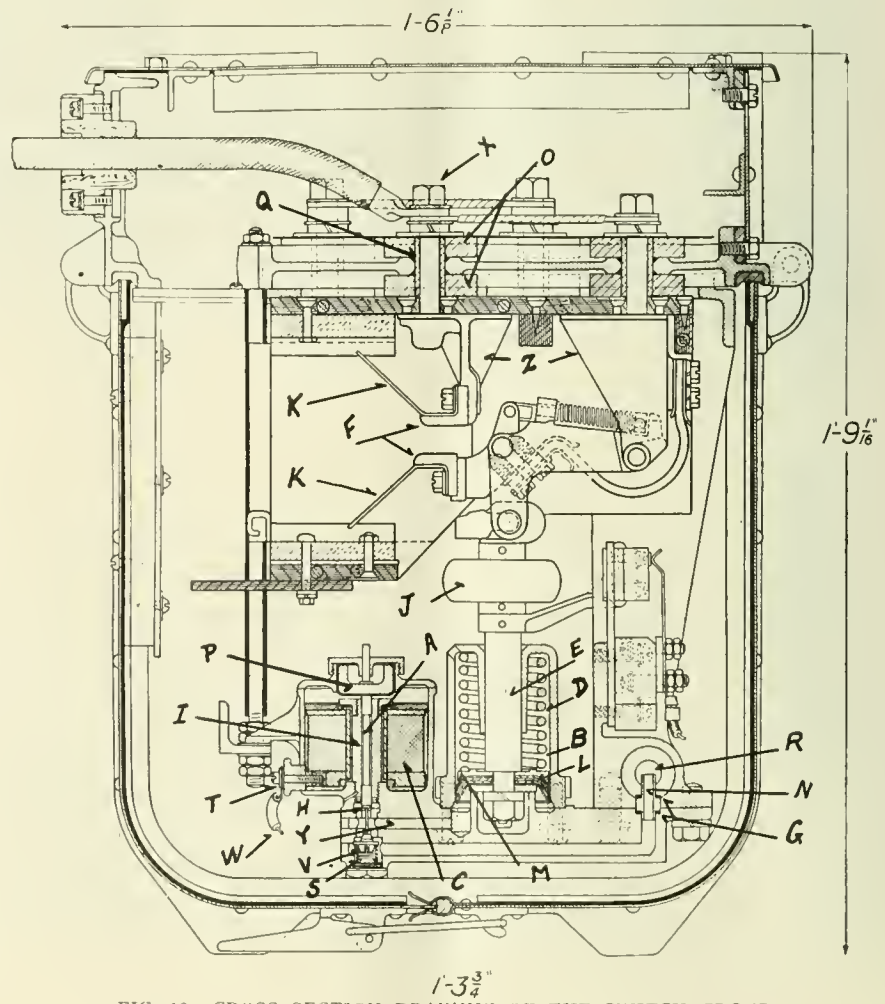

FIG. 12. CROSS SECTION DRAWING OF THE SWITCH GROUP.



Q. What is the construction of one of these units?

A. A cross section through one of these switch units is shown by Fig. 12. The air is piped into the end of the group and supplies air at 70 pounds pressure to the small reservoir "R" running the whole length of the group. Each of the cylinder

A. When the engineer shuts off the master controller, the battery current is broken from the control wire, the coil "C" is no longer energized, no attraction therefore exists on the armature "I" and the small valve "V" closes on its seat by means of the spring "S," thereby cutting off the air pressure from the passageway

treated and specially formed in a cup shape and are extremely satisfactory. It is noted that these leathers are assembled with a cast iron follower "M," cup shaped so as to maintain the leather in the correct position.

Q. How does the closing of the contacts "F" connect the power to the motors?

A. Referring to Fig. 11, the cables are shown on the top of the group. These cables enter through the side as shown in the sectional view Fig. 12 and the terminals soldered to the ends are bolted down by the studs "X." These studs pass through the top framework of the group, being insulated therefrom by means of insulated washers "O" and tube "Q" and screw into the copper casting "Z" to which are bolted the copper contacts "F." The main current, as can be seen, enters and leaves the top of the group and the main circuits are entirely independent of the control circuits. In order to insulate the current from the control apparatus an insulator "J" is placed in the piston "E" so that the power flowing through the contacts "F" is entirely eliminated from the rest of the apparatus.

Q. What is the object of the horns "K-K"?

A. These are arcing horns and, as name suggests, are used to take care of the arc which forms when the contacts "FF" open breaking the main circuit. The arc which forms across the tips of the contacts "F" is carried out along the arcing horns "K," becoming of greater and greater length and when it reaches the end of these arcing horns is blown out and the circuit is interrupted.

Q. What means is provided to aid in the blowing out or extinguishing of the arc?

A. Referring to Fig. 11, it is noted that there are spaces between each of the switches. This space is not vacant, but is occupied by a blow-out coil Fig. 14. The blow-out coil consists of a few turns of copper strap and the connection to it is made by the studs as shown in the figure. The arrangement of main circuits is such that the current flows through these blow-out coils before it passes through the switches, so that when the contacts open and an arc is formed current is still passing through these blow-out coils and a magnetic action is set up which extinguishes the arc. The coils are close to the contacts on either side and a strong magnetic field exists at right angles to the contacts. The arc formed when the contacts open (the arc is a current flowing through the air) takes place in a magnetic field and, according to the laws of magnetism and electricity, moves at right angles to this field. The arc is, in other words, blown out magnetically, and this is one of the fundamental principles of this design and the reason for its great success. The time taken to blow out this arc is almost instantaneous.

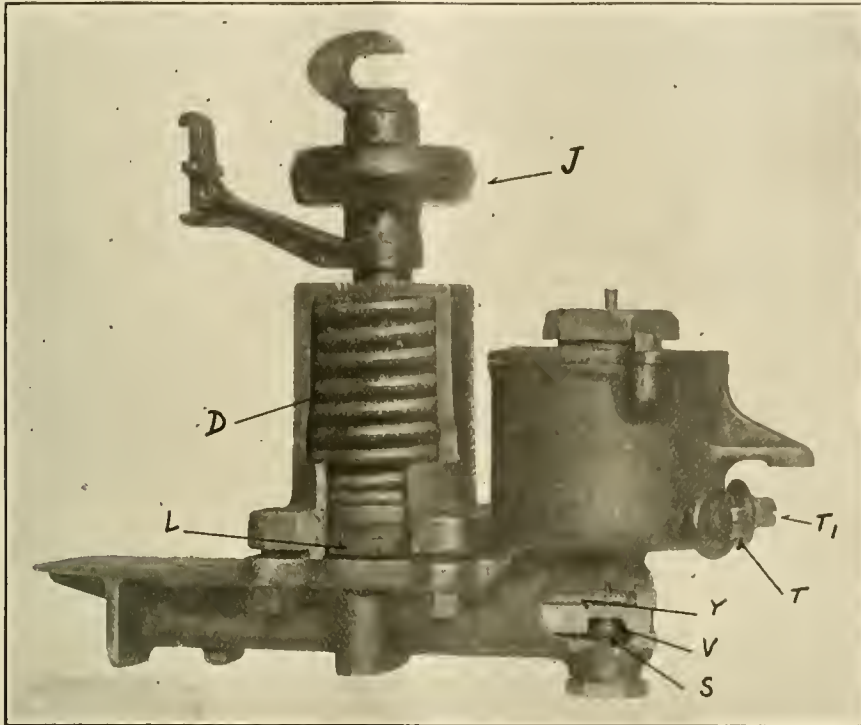

FIG. 13. CYLINDER AND MAGNET VALVE CUT TO SHOW WORKING PARTS.

and magnetic valves shown by Fig. 13 receives air from this reservoir "R" through the nipple "N," gaskets "G" being used to prevent leakage of air. The 70 pounds air pressure is therefore always available around the head of the small valve "V" held on its seat by the spring "S." When the engineer operates the master controller, thereby connecting the battery power to a control wire, the battery current flows through the wire "W" into the terminal "T" through the coil "C" and out of the terminal "T<sub>1</sub>." The flowing of the battery current through this small coil magnetizes the iron center or core "I" and the small cup shape piece of iron "P" called the armature is drawn down by the magnetic attraction. In the position shown in this cross section, the cup shape armature rests on the top of a long stem valve "A," so that when the armature is drawn down the pin "A" is pushed down and same in turn pushes down the valve "V" away from its seat. Seventy pounds air pressure can then pass up through the opening into the passageway "Y" leading into the cylinder "B." The air entering the cylinder compresses the heavy spring "D" and pushes up the piston rod "E" forcing the switch contacts "FF" together establishing the main circuit to the motors.

Q. How is the switch or main contacts opened?

"Y." It is noted that the end of the stem "A" pushed down by the armature also forms a valve and when in the down position closes the opening "H." This is the exhaust valve seat, so that when the coil is energized and air pressure is admitted to the passageway "Y," it is retained in the cylinder and has no exhaust

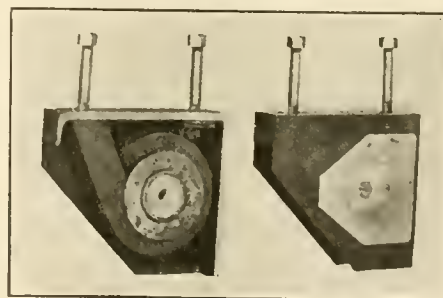

FIG. 14. BLOW-OUT COIL.

to air. However, when the valve "V" re-seats there is an opening at "H" due to the pin "A" raising and the air in the cylinder can pass out to atmosphere through "H." This air is expelled by means of the heavy spring "D" and the contacts "F" are opened rapidly.

Q. What packing is used in the cylinders?

A. The packing consists of triple leathers "L," these leathers being specially

# Development of the Locomotive

Address by Dr. ANGUS SINCLAIR, Special Instructor of the Erie Railroad

The following presents the principal parts of an address delivered by Dr. Angus Sinclair, special instructor of the Erie Railroad, to a class of apprentices:

I have been interested in locomotives for years,—in fact ever since I was born. The first remembrance that I have about locomotives was that my mother held me up in her arms when an important locomotive was coming into the town where I was born. I cannot say that it was a consolidation or a mogul or anything of that sort, but it seemed to me a tremendously fine looking thing. My father was a railroad man and he thought I should follow in the same trade, and that I should be "stuck" on a locomotive, and that is the kind of a machine that I have been making the most of ever since.

I have been talking about locomotives ever since I remember, and there are some things that I may forget and some things that I may ignore in regard to that form of a machine; but so far as not being able to talk for an hour or two, that is entirely out of the question. When anyone is in love with a subject and has been in love with it for 35 years or so, as I have been, he is liable to have the faculty of dilating to a certain extent about it, and so it seems to be quite natural for me to talk to any extent about the locomotive engine, and those that are connected with it, primarily and in the line of development.

The locomotive is one of the most important lines of development of the steam engine. It is a very long time ago since scientific men got to recognize that there was something tremendously powerful in steam, i. e. in steam being confined in some vessel. We go away back to the Greek history, to the time of Alexander, about 2,500 years or more ago, looking after scientific data, in regard to what were the possibilities of steam.

My own opinion is that the possibilities of steam arose from the housewife who got in the habit of putting a pot on the fire and putting a cloth around the pot, and used her best efforts to prevent the escape of the juices from the pot. Of course the tighter the lid was held and the more weight she put on the pot, the greater the pressure would be inside, and if she was not very careful, then there would be an explosion, because the pressure inside would get beyond the resistance of the metal. Then there would be all sorts of reasons given concerning the cause,—the most popular one being that the devil was in the pot. They could never boil a pot very fast without wondering whether the devil was in it or not. He was the gentleman who explained all the scientific phenomena at that time, and anything that the devil had not ex-

plained was liable to be explained in some other way. Then the scientific chaps took it up, and they had their way of explaining it. They got to explain that the pressure of steam could move anything that it touched. Well, I suppose you all know about the injector. The earliest efforts to move anything with steam was something similar to the principle of the injector. They rushed the water up into a tank and they used a vacuum in connection with it, and for 2,000 years the scientific men of all the enlightened world tried to do work by the injector principle. Now, I need not explain the injector principle to you, but they tried and tried and tried from Sir Isaac Newton's time up till 1710 or so. They tried everything that could be done with compressed steam. They got to make vessels that would hold steam of very great pressure, but they could not raise water economically. They were trying to raise water out of deep mines, until about 1710, when a working blacksmith in the south of England got the idea that he could use a piston and employ the atmospheric pressure on one side, and then put the pressure of steam on the under side. That was known as the Newcomen atmospheric engine. That was the greatest advance in the whole world's history in trying to make the heat of coal do mechanical work. You see after all,—you may call it steam, hot water condensed, or whatever you desire to call it, but it is the power that you get from burned coal that will evaporate water which is the principle of the steam engine. Nowadays we hear a great deal about the use of electricity and what electricity is going to do, and what compressed air is going to do, but after all if you look backward, you will find that the principle of motive power is a steam engine, that is being operated by boiling water and giving it the power that it can do the work with. That is a thing that you all ought to have a thoroughly good idea of. Electricity is merely a belt,—it is a belt that will convey the power of the steam engine to a trolley or to anything else in that line, or will transmit the power to a compressed air engine, but when you go far enough back, you always come to the coal heap and the fellow who is shoveling the coal into the furnace. That is the first principle of steam engineering.

After a time when they got to be able to run factories with steam power, etc., it came to the minds of a great many people that a very important problem in the world's advance was: What would shorten distances and what would send out lines of cheap transportation into the prairies and wildernesses of the world. There was no country in the world where

the opportunity was so great as America. The country was merely peopled on the sea coast; a great, vast, unproductive country was standing waste, because no one could go to it, except on the edge of the seaboard and on the edge of the rivers. The best thoughts of the day went to try and get some means that would push into this inland, over the untrodden prairie, through those great wildernesses and forests, that could give any amount of freight if a line could be sent in to take it away. The idea struck a great many of our people about the same time, that the nature of that line was railways operated by the locomotive. It is generally understood that the railway business originated in Great Britain. In Great Britain was made the first very decided success, but at the same time the engineers of America were working out the problem of inland transportation and if the Liverpool & Manchester Railroad had never been opened, with its great Stephenson's "Rocket" and the other inventions for the advancement of transportation by rail and by steam, America would not have been a half dozen years before she would have been right in the front,—just as far as the Liverpool & Manchester was in 1829. Less than a year afterwards, Peter Cooper, whose statue is in front of the Cooper Institute on the Bowery, made a locomotive, and did not ask anyone to help him how to design it. He put it on the Baltimore & Ohio Railroad where he was very much interested and the experiments and the experience with that little bit of a locomotive, which was called the "Tom Thumb" and did not exceed three or four horsepower, was more efficient than the efficiency of the "Rocket" that became so famous in the world's history through Stephenson's work on the Liverpool & Manchester. Peter Cooper was by no means the first man on this American continent to experiment on what could be done with the steam engine as a movable, traveling engine. One of your own residents of Hoboken, Robert Stevens in 1825, four years before Stephenson's "Rocket" was tried, built an engine and used gun barrels for flues in his boiler, and ran it around on a 25 radius track, mostly for the amusement of his friends. Not only for the amusement, but for a great object lesson of what the possibilities were of a high pressure engine to do such work. That same Robert Stevens was a constant and inveterate advocate of having a railway from here to Philadelphia and from Philadelphia to Washington. He met with no end of obstacles in the effort that he was making; but in all his writings, and he was one of the great est engineers that this country has ever

had, and one of the first who deserves consideration as an American engineer, he argued—"you may talk about steamboats or canals. A canal is stopped half the year on account of being frozen up. You want to have cars that will not freeze up and will go from here to Philadelphia and from there to Washington and all over the country, to develop the commerce and the possibilities of these vast fields that we have nothing at present from, but just grass and a little wood. You want to develop this." That was the right move to develop the country. I think that the men of Hoboken, the men of my own Jersey state, cannot be too proud of what that great engineer of our earliest time did to arouse the spirit of the day, and said, "Let us be doing and let us not fall behind the world in these efforts."

In regard to the locomotive—there were certain peculiarities about the difficulties of getting a good working locomotive going in the first few years of its history. That did not seem to come to our country, however. I think that most of you who are reading men anyway will be aware that there was a certain engineer, away 20 years before last century opened, whose name was Oliver Evans. I judge that he was a Welshman. However, he was an engineer and a mechanic, and while James Watt of Glasgow was recommending the condensing engine, Evans kept recommending the high pressure engine, not condensing but high pressure steam, and an engine that would run with high speed. Any of you who are at all well acquainted with the engine of the early days know that in Watt's time a speed of 25 revolutions a minute was quite high, but Oliver Evans, who was a contemporary of Watt, believed in 50 or 60, or even 150, revolutions, and he believed in very high pressure, steam and quick action, so there came to be a rivalry between him and Watt in connection with these engines. Evans became known as the high pressure and high speed engine, and Watt as the low pressure condensing engine. Now, when the proposition was made to make a moving engine—an engine that would go over the road, Watt tried it, but he gave it up. He said there was nothing in it. He was accustomed to his ten revolutions and condensing engine. Oliver Evans said there is a great deal to it. We can save steam by running 150 revolutions and getting a great deal of power out of a light engine. Watt took about two tons per horse-power for his engine. Oliver Evans took about 200 pounds per horse-power, and the conflict started out between Oliver Evans and James Watt as to who could make the most efficient engine with a certain amount of weight. There never was any question that Oliver Evans beat Watt, and there was never any question by those who have been fair about it, that the peculiarity of the American engine was that it was high

pressure, high speed and light weight. That is the peculiarity of the American engine to-day, and that was what made our locomotives a success from the very start. Now, I am not a particularly old man, you will see that my hair is getting a little gray, and still I have seen the first locomotive in my boyhood, or those that were equal in time to the first that was put into service, and my remembrance of the English locomotive is that it did not have any high steam pressure and did not have any pushing power in turning the wheel quickly. They were always wanting to go pretty slow, that is the English style of it. That was my own experience there. When I came to this country and saw what they had here, although I came just like lots of my own countrymen, mightily prejudiced against anything Yankee, I realized the great difference. Everything here was all push and get there.

#### Original Discovery of Iron.

In addressing one of the Eric Railroad apprentice schools on "The Progress of Science," Dr. Angus Sinclair said: One of the most useful discoveries made by pioneer scientists was the means of separating metallic iron from its ores. There was a time, long ago, when iron was not in use, and its place was indifferently filled by bronze and other alloys of copper. The discovery of metallic iron may have been accidental, but it must have been done by men of keenly observing habits. Men possessed of observing habits have done more to keep the world progressing than any other class. The opportunities for the observing man to prove his work are more numerous to-day than they ever were.

History tells not when the process of refining iron was first performed; but it is supposed to have been done in Spain where a crude form of furnace called a Catalan forge for many years supplied most of the iron used. The Catalan forge was no doubt a development from cruder forms. Going to the beginning of discovery in this line of progress we can well imagine a group of shepherds building a great fire whose heat melted the rocks on which it rested, and that the melted mass excited the curiosity of the men who had started the fire. Being men they would naturally make experiments with the mass which heat had changed so strongly.

This observation once made, then would follow experiments to determine the conditions under which the metal was produced, and the substances necessary for its production. Then the power of the keen observer would be made manifest, and he would notice that certain forms of earth or rocks did most to produce the metal, and that a certain intensity of fire heat was necessary to melt the substance.

But the iron thus accidentally produced—a mixture of iron, cinder and ashes—was of no value till further experiment revealed the fact that the metal when hot could by hammering into one mass cause the separation of cinder and other extraneous matter. The discovery of this property prompted still further operations. The irregularity of the product would suggest the more perfect control of the fire which led to the building of small furnaces. In the course of time it would be noticed that the iron was not uniform in hardness, and an accident would be sure to reveal the fact that sometimes the metal, when suddenly cooled in water, would turn out intensely hard. The resulting investigation would end in the production of steel. And so the industrial world could be provided with the best metal ever fabricated for the use of mankind.

#### The Unexpected in Mechanics.

In practical work an engineer meets with many things that do not act according to the laws laid down in the mechanical text books. This is particularly noticeable in the friction of different substances rubbing together. In fact there is positive reason to believe that many of the so called laws of friction have been established on insufficient data. As an example, it is generally asserted that the friction between two metals will be uniform when the conditions of pressure are the same, but those who have had much experience with brake shoes and journal bearings are constantly meeting with highly different results when it might be expected that there would be uniformity. Abstractedly an engineer would reason that there would be about the same amount of wear when a cast iron driving box was used with a cast steel driving wheel, as there would be with a cast steel driving box and a cast iron wheel. Yet, the difference is so great, that cast steel boxes must be lined with a soft metal to prevent excessive wear; but a steel wheel runs against a cast iron box as free from wear as one made of cast iron.

The more experience a man has with inventions designed to improve railway machinery, the less is he inclined to guarantee whether or not a new thing will succeed until he has seen it tried in actual service. We have repeatedly been humiliated with things utterly failing that we were ready to risk our reputation and our small capital upon performing the work for which they were designed.

#### Just a Way They Have.

"Say, conductor," remarked the inquisitive passenger. "in speaking of time, which is proper, 'a quarter to six' or 'a quarter of six'?"

"I'm sure I don't know," replied the railroad man. "I always say 5:45."

# Items of Personal Interest

Mr. A. R. Baldwin has been appointed master mechanic of the Anthony & Northern, with office at Pratt, Kan.

Mr. John L. Smith, Jr., has been appointed master mechanic of the Pittsburg & Shawmut, with office at Brookville, Pa.

Mr. G. A. Haggander has been appointed bridge engineer of the Burlington lines, succeeding Mr. C. H. Cartledge, deceased.

Mr. C. B. Gray has been appointed master mechanic of the Pennsylvania, with office at So. Pittsburgh, Pa., succeeding Mr. A. W. Byron.

Mr. C. F. Bennett, formerly valuation engineer for the Chicago & Western Indiana, has resigned to become cost engineer of the Baltimore & Ohio.

Mr. G. W. Wilson has been appointed car foreman of the Grand Trunk Pacific, with office at Lambton, Ont., succeeding Mr. J. Tregaskis, promoted.

Mr. James Medland has been appointed shop foreman on the Buffalo, Rochester & Pittsburgh, with office at Clarion Junction, Pa., succeeding Mr. E. F. Houghton.

Mr. N. R. Elmoro has been appointed acting master mechanic of the Nevada Southern, with office at East Ely, Nev., succeeding Mr. H. Selfridge, resigned.

Mr. Thomas Windle has been appointed acting master mechanic of the Midland Valley, with office at Muskogee, Okla., succeeding Mr. C. D. Powell, resigned.

Mr. F. H. Cramer, formerly designer in the bridge department of the Chicago, Burlington & Quincy, has been appointed office engineer, succeeding Mr. A. Engh.

Mr. N. B. Whitsel, formerly general foreman of the Chicago & Western Indiana, has been appointed master mechanic on the same road, with office at Chicago, Ill.

Mr. G. W. Cuyler has been appointed master mechanic of the St. Louis and Kansas City terminal divisions, with office at Armourdale, Kans., succeeding Mr. R. J. McQuade.

Mr. W. G. Cook, recently appointed assistant to the general sales manager of the Garlock Packing Company, has been appointed manager of the Chicago branch of the company.

Mr. A. W. Standiford, formerly general foreman of the Chicago & Eastern Illinois, at Salem, Ill., has been appointed master mechanic, at Evansville, Ind., succeeding Mr. W. F. Heiser.

Mr. F. W. Behan, formerly erecting foreman of the Grand Trunk Pacific, at Transcona, Man., has been appointed locomotive foreman on the same road, with office at Regina, Sask.

Mr. R. J. McQuade has been appointed master mechanic of the Kansas division of the Chicago, Rock Island & Pacific, with office at Herington, Kans., succeeding Mr. P. W. McCarthy, transferred.

Mr. A. P. Pendergast, superintendent of machinery of the Texas & Pacific, has transferred his office from Marshall to Dallas, Tex., and his jurisdiction has been extended over the fuel bureau.

Mr. R. E. McCuen, formerly master mechanic of the Lexington & Eastern, and assistant master mechanic of the Louisville & Nashville, at Lexington, Ky., has resigned to engage in other business.

Mr. N. H. Ivers, formerly with the Baldwin Locomotive Works, has been appointed southwestern representative of the Gold Car Heating & Lighting Company, New York, with headquarters at St. Louis, Mo.

Mr. R. J. Himmelright, formerly assistant to the manager of the service department of the American Arch Company, has been appointed manager of the department, succeeding Mr. J. T. Anthony, promoted.

Mr. R. J. O'Neil, formerly master boiler maker of the Colorado & Southern, at Denver, Colo., has been appointed chief boiler inspector, of the city of Denver, with jurisdiction over smoke and electric inspection.

Mr. D. Cunningham, formerly shop superintendent of the Denver & Rio Grande, at Salt Lake City, has been appointed superintendent of motive power of the Denver & Salt Lake, with office at Denver, Colo.

Mr. A. E. Dales, formerly district master mechanic of the Canadian Pacific, at Brandon, Man., has been transferred to the Fourth district with office at Edmonton, Alta., succeeding Mr. A. West, transferred to Brandon.

Mr. J. T. Anthony, formerly manager of the service department of the American Arch Company, New York, has been appointed assistant to the president. Mr. Anthony has had considerable experience as a railroad man, and is an acknowledged leading authority on combustion.

Mr. P. W. McCarthy, formerly master mechanic of the Kansas division of the Chicago, Rock Island & Pacific, at Herington, Kans., has been appointed master mechanic in charge of the shops at Horton, Kans., reporting to the mechanical superintendent at El Reno, Okla.

Mr. H. G. Reid, formerly master mechanic of the Saskatchewan division of the Canadian Pacific, at Moose Jaw, has been appointed master mechanic of District No. 3, of the National Transcon-

tinental, with office at Transcona, Man., succeeding Mr. J. Borse, transferred.

Mr. F. E. Starkweather has been appointed signal engineer of the Pere Marquette, and Mr. J. J. Evans, formerly supervisor of signals, at Saginaw, Mich., has resigned to engage in other work, and is succeeded by Mr. C. A. Nelson, formerly chief draftsman in the signal department.

Mr. W. Sherman Humes, formerly in the motive power department of the Pennsylvania, at Altoona, Pa., and latterly sales manager of the General Railway Supply Company at Chicago, has accepted a position with the Hewitt Company, Chicago, in the manufacture of anti-friction metals and locomotive packing.

Mr. G. D. Hood has been appointed superintendent of telegraph of the Chicago, Rock Island & Pacific, with headquarters at Chicago, Ill., succeeding Mr. C. H. Hubbell, transferred, and Mr. B. B. Shaw, formerly assistant engineer, at Haileyville, Okla., has been appointed division engineer of the Arkansas division, with headquarters at Little Rock, Ark., succeeding Mr. J. G. Bloom, promoted.

Mr. E. T. Sawyer, who has been associated with the Commercial Acetylene Railway Light & Signal Company for over eight years, has resigned to accept a position as sales engineer with the Edison Storage Battery Company. Mr. Sawyer from about 1901 to 1904 was with the western office of the Dressel Railway Lamp Works, of New York, and the Star Brass Manufacturing Company, of Boston. He later spent four years in the employ of the Acme Ball Bearing Company as manager of the railway department. His first three years in the employ of the Commercial Acetylene Railway Light & Signal Company were spent as southern manager. For the last five years he has been connected with the main office at New York.

Mr. G. A. Trube has been appointed export manager of the Westinghouse Air Brake Company and the Westinghouse Traction Brake Company, effective August 1, 1916, with headquarters at Pittsburgh, Pa. Mr. Trube has had a wide foreign experience, having been associated with the Westinghouse Air Brake and Westinghouse Electric interests for many years, both in this country and abroad. He went to England in 1900 to carry out some special work and soon afterwards made his headquarters there until January, 1912, when he was transferred to Paris to become managing director of the French Westinghouse Company, which position he has now resigned in order to return to this country and take up his new duties here.



## A Clear Track

ahead, Railway men, when you protect your metal work with

# DIXON'S Silica Graphite PAINT

It has a world-wide reputation of over fifty years. Made in **FIRST QUALITY** only. Made for those who want **QUALITY, LONGER SERVICE** and **LOWEST COST** per year of service.

Because of the peculiar oily nature and flake formation of the pigment, Dixon's Paint has no equal in keeping moisture and gases away from the metal. Therefore metal properly painted with it resists corrosion longer than that painted with any other paint. That is the reason why leading railroads throughout the entire world use it as standard.

Write for booklet 69-B and long service records.

Made in **JERSEY CITY, N. J.**, by the

**Joseph Dixon Crucible  
Company**

ESTABLISHED 1827

B 132

### Railroad Equipment Notes.

The Philadelphia & Reading is building 10 switching locomotives in its Reading, Pa., shops.

The New York Central has ordered 10 electric locomotives from the General Electric Company.

Northern Railway of Spain has ordered 15 locomotives from the American Locomotive Company.

The Michigan Central has ordered 500 center constructions from the Pressed Steel Car Company.

The Pittsburgh & Lake Erie has ordered 10 locomotives from the American Locomotive Company.

The Boston & Albany has ordered five Mallet type locomotives from the American Locomotive Company.

The New York, New Haven & Hartford has ordered four all-steel dining cars from the Pullman Company.

The British government has ordered 45 narrow gauge locomotives from the Baldwin Locomotive Works.

The Chesapeake & Ohio has given the Western Steel Car & Foundry Company an order to repair 250 box cars.

The New Orleans & Northwestern has ordered 100 30-ton box car bodies from the American Car & Foundry Company.

The Southern Railway has completed an 18-stall roundhouse and made other terminal improvements at East St. Louis, Ill.

The Pierce Oil Corporation, St. Louis, Mo., has ordered 50 50-ton tank cars from the American Car & Foundry Company.

The Michigan Central is reported to have ordered five Pacific type locomotives from the American Locomotive Company.

The United States government has been getting prices on 50 armored cars, also 3 mine rescue cars for the Interior Department.

The Cleveland, Cincinnati, Chicago & St. Louis has ordered five Pacific type locomotives from the American Locomotive Company.

The Nevada Consolidated Copper Company, New York, has ordered two 0-6-2 type locomotives from the Baldwin Locomotive Works.

The Pennsylvania Railroad recently received bids on 1,000 to 1,200 tons of steel for a freight house and bridge work at Connellsville, Pa.

The Ponca Refining Company, Oklahoma City, Okla., has ordered 40 40-ton steel tank cars from the American Car & Foundry Company.

The Great Northern will expend about \$100,000 on a coaling station, oil house, roundhouse and other terminal improvements at Sioux City, Ia.

The Baltimore & Ohio has bought 1,500 100,000 pounds capacity hopper cars from the Jamison Coal & Coke Company, Oliver building, Pittsburgh, Pa.

The Baltimore & Ohio will install complete automatic block signals on the Cumberland division, using the Federal Signal Company's type "4," 10-volt d. c. signal mechanisms.

The Sapulpa Refining Company, Sapulpa, Okla., has ordered 160 8,000-gallon capacity tank cars and 40 10,000-gallon capacity tank cars from the General American Tank Car Corporation.

The Russian Government's recent order for 28,000 axles and about 56,000 cast iron wheels was divided about equally between the Pressed Steel Car Company and the American Car & Foundry Company.

The New York Central has ordered 1,000 box cars from the Haskell & Barker Car Company for the Lake Erie & Western, and 1,000 box cars from the American Car & Foundry Company for the New York Central itself.

The Russian Government has ordered nine Mogul locomotives from the American Locomotive Company. These locomotives will have 11 by 16-in. cylinders, 33½-in. driving wheels and a total weight in working order of 37,000 pounds.

The Italian State Railways have ordered 60 superheater Consolidation locomotives from the American Locomotive Company. These locomotives will have 21¼ by 27½-in. cylinders, 53½-in. driving wheels, and a total weight in working order of 146,000 pounds.

The Mogyana Railway, Brazil, has ordered three Pacific type locomotives from the American Locomotive Company. These locomotives will have 17½ by 20-inch cylinders, 45-inch driving wheels, a total weight in working order of 118,000 pounds, and will be equipped with superheaters.

### Fast Express Trains Here and in Europe

People who have been traveling on the railways in Europe frequently come back boasting of the high speed at which trains are run on the other side of the Atlantic. Few railroad managers on this side of the ocean display ambition to run their trains at high speed because they are aware that it does not pay, but that is the only reason why our trains are not run as fast as express trains in Europe. Besides, the people traveling in European express trains imagine that they are running at excessive speed when the pace is moderate because the short cars universally used on European railways jump and lurch much worse than the long heavy cars used on the American continent.

Although fast express trains are not common in America, there are a few that compare in speed with the fastest trains found abroad. The Empire State Express on the New York Central Railroad makes the run from New York to Buffalo, 439½ miles, in 8 hours and 40 minutes, an average of 50.71 miles an hour, including stops, the ordinary weight of train being 175 tons.

From Euston, London, to Perth, Scotland, 450 miles, the run is made in 9 hours and 50 minutes, an average of 45.76 miles an hour including stops, weight of train 80 to 130 tons. On the Great Northern & Caledonian Railways a train is run from Kings Cross, London, to Perth, 439 miles, in 9 hours and 55 minutes, an average speed of 44.27 miles an hour including stops, the train weighing about 130 tons.

### Railway Passenger Recommended to Walk.

There have nearly always been differences of opinion between carriers and the carried as to the equity of transportation charges. We happened lately upon a discussion in a British publication of 1846, which to us seems very amusing, although it merely brings back sentiment very common in the good old times. A traveler, having complained of the excessive charge for travel on what was then a minor railway, received the following explanation from the general manager:

"It is true we charge you twice or thrice the fares exacted in other countries, but you paid more on stage coaches before we enabled you to travel comfortably in a railway coach. We have accelerated your journey and given you every luxury that a traveler could desire, carrying free three times the amount of baggage you would have taken on a stage coach. What right have you to complain of high fares when you enjoy so many advantages in return? If you dislike our charges you are not compelled to pay them. You are

at perfect liberty to use the turnpike, and if you prefer the old coaching practices introduce them again. Only in God's name stop uttering complaints against the benefactors of the country."

That may seem an odd way of treating complaints against a railway company, but it was very common in the British Isles during the first half century of railway operating. Railway managers for many years thought abusing the traveling public was one of their natural privileges.

### Question of Firing.

A Progressive Fireman writes us: There is a difference of opinion in regard to a point of firing that several engineers would like you to settle through your valuable paper that we all read with interest. I am firing a passenger engine, a good Baldwin that carries 180 pounds of steam. Fifty-five miles of the division is up hill; between that point and the terminal 82 miles is up hill and down hill. The point in dispute is as to the best method of saving coal. Some claim that by firing an engine at from 120 to 140 pounds and regulating its fire so that the pressure will not advance to the blowing off point is best. I claim that you lose coal by so doing. The engines are free steamers and you have to let your fire burn so low that when you fire her up and throw green coal into the firebox, it will not ignite at once, down goes your steam and consequently you have to work under disadvantages. But by keeping a good fire to work on and carrying from about 170 pounds of steam you can save coal without permitting your engine to blow off.

A YOUNG FIREMAN.

We prefer your method but should like the opinion of other engineers.

### An Ancient Industry Revived.

Although Persia, like many other oriental countries, has lain for centuries in a sort of comatose condition, the time was when Persia was first in war and peace. An art in which Persia blacksmiths attained great perfection was the forging of sword blades, the Khorassan sword, with its wavy steel, having rivaled in temper the famous Damascus swords. Some years ago a collector of antique curiosities began buying Persian swords and the supply soon proved exhausted. But the demand had arisen, and some enterprising Persians undertook to meet the demand, and they entered into the business of making antique Khorassan swords, and the business is flourishing.

Respect for human life and tenderness towards every form of human suffering is one of the most marked features of the best modern culture.

# GOLD Car Heating & Lighting Company

Manufacturers of

ELECTRIC,  
STEAM AND  
HOT WATER  
HEATING  
APPARATUS  
FOR RAILWAY CARS  
VENTILATORS  
FOR PASSENGER  
AND REFRIGER-  
ATOR CARS  
ACETYLENE SYSTEM  
OF CAR LIGHTING

Send for circular of our combination PRESSURE AND VAPOR SYSTEM OF CAR HEATING, which system automatically maintains about the same temperature in the car regardless of the outside weather conditions.

Main Office, Whitehall Building  
17 BATTERY PLACE  
NEW YORK

# Hydraulic

**Riveters Fixed and Portable  
Punches, Shears,  
Presses, Lifts, Cranes  
and Accumulators.**

**Matthews' Fire Hydrants,  
Eddy Valves  
Valve Indicator Posts.**

**The Camden High-Pressure Valves.**

## Cast Iron Pipe

**R. D. Wood & Company**

**Engineers, Iron  
Founders, Machinists.**

**100 Chestnut St., Philadelphia, Pa.**

## Nichols Transfer Tables Turntable Tractors

**GEO. P. NICHOLS & BRO.  
1090 Old Colony Bldg. CHICAGO**

## For Testing and Washing Locomotive Boilers

USE THE

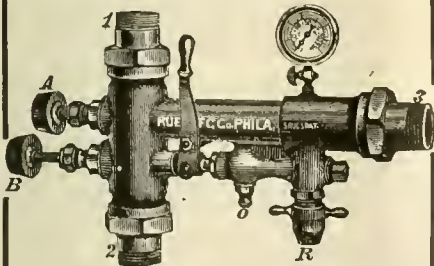

## Rue Boiler Washer and Tester

SEND FOR CATALOGUE

**Rue Manufacturing Co.  
228 Cherry Street Philadelphia, Pa.**

Manufacturers of Injectors, Electors,  
Boiler Washers and Testers, Boiler Checks,  
Check Valves.



## ASHTON POP VALVES AND GAGES

The Quality Goods That Last

The Ashton Valve Co.  
271 Franklin Street, Boston, Mass.  
No. 174 Market St., Chicago, Ill.

# Books, Bulletins, Catalogues, Etc.

**ELECTRIC MOTORS DIRECT AND ALTERNATING.** By D. P. Moreton, B. S., E. E. Published by Frederick J. Drake & Co., Chicago. 241 pages. Illustrated. Cloth. Price, \$1.50.

This book is divided into twelve chapters, each taking up some particular phase of the work so that the student is led by easy stages to a complete mastery of the subject. The first three chapters treat in detail all the fundamental principles of electric and magnetic currents. Then follow the methods of measuring currents, pressure, resistance, and power. Armature windings for both direct and alternating currents follow. Several chapters are devoted to the different types of direct-current motors, their construction, operating details, speed control, and the treating of troubles. Alternating-current motors are fully described in the closing chapters. Examples are given throughout the work, and these with the aid of the excellent illustrations leave nothing to guesswork. The accomplished author who is Associate Professor of Electrical Engineering in the Armour Institute of Technology has performed a notable service in this valuable book which will be appreciated by advanced students as well as beginners.

**OFFICIAL PROCEEDINGS OF THE TENTH ANNUAL CONVENTION OF THE MASTER BOILER MAKERS' ASSOCIATION.** Harry D. Vought, secretary. 206 pages, with numerous illustrations. Price \$1.00.

This is a carefully compiled report of the proceedings of the tenth annual convention of the Master Boiler Makers' Association held at Cleveland, Ohio, last May, and is in itself a strong indication of the growing influence of the association. With a membership approaching the 500 mark, the large majority of whom are occupied in official positions on the leading railroads, they may justly be said to be in the fore front of their occupation as constructors and repairers of boilers, mostly locomotive boilers, and the papers presented by the committees and the discussions on the same may be looked upon as the best expression of the best thoughts in our time on boiler construction and maintenance.

**HOW TO BUILD UP FURNACE EFFICIENCY.** By Joseph W. Hays. Published by the author, Rogers Park, Chicago. 156 pages. Illustrated. Price \$1.00.

This handbook on fuel economy with hints on industrial efficiency and other matters, and now in the tenth edition, has had the distinction of being translated into several European languages. It applies largely to the saving of fuel in stationary plants, and explains in a simple and di-

rect way how fuel is wasted, how to discover the wastes, how to stop the wastes, and how to keep the wastes stopped. There is also a valuable appendix on oils, gas, refuse and other fuels. It is altogether a unique work of its kind, and well worth the perusal of all who are interested in the important subject of fuel economy. It contains much real information illumined with common sense, and has the rare merit of being easily understood.

**ELECTRICAL TABLES AND ENGINEERING DATA.** By H. C. Horstman and V. H. Tousley. Published by Frederick J. Drake & Co., Chicago. 331 pages. Illustrated. Cloth. Price, \$1.50.

This book admirably meets the requirements of practical electricians, furnishing as it does a vast amount of practical information which is constantly called for but very seldom available at the moment when most needed. The style of the authors is clear and direct and entirely free from theoretical discussions. A notable feature is the references to almost every conceivable condition or place where electricity may be used either in generation, transmission, motive power or lighting. The alphabetical order in which the subjects are arranged makes every item readily found without any delay. As to the tables provided to assist in the calculation of all kinds of problems with which construction men have to deal there seems to be nothing left where tedious calculations are required to be made. The book cannot fail to meet with much popular approval among electrical workers.

### Reactions.

The Goldschmidt Thermit Company's quarterly publication for the second quarter of 1916 is more than usually interesting on account of an interesting description and illustrations of the largest weld ever made. It consisted of repairing a broken blooming mill shear. The broken piece was of irregular shape, approximately 37 inches wide by 60 inches long, and weighed about 3,000 pounds. The operation was finished in three days and so neatly was the job done that no machine work was required. Rail welding, and a large number of railroad shop repairs, particularly of locomotive frames, are also described and illustrated. Among other seemingly difficult welds is that of a locomotive driving wheel in which six spokes were welded close to the hub and crank pin. It is the biggest job of its kind that has been done in the shops of the Boston & Maine. It was finished in one operation, and required about 300

pounds of thermit. There is seemingly no limit to the possibilities of thermit welding. Copies of the quarterly may be had on application at the company's new offices, 120 Broadway, New York.

**The Spirit of Caution.**

"The Spirit of Caution," published by the Conference Board on Safety and Sanitation in Massachusetts, seems to be gaining ground. It is a 16-page pamphlet published every two months, and is full of good advice. It has many graphic illustrations showing how easy it is to get killed, with a few visions of how to live a long time. Those who care to live long should secure a copy of this publication. Its only weak point seems to be that it does not point out what old people should do with themselves. Of course the old age pension system is growing, but it is growing very slowly. Of course we should not expect too much from any single periodical. The one before us is doing its work well, and gives promise of a long life. Copies may be held for a dollar a dozen from the secretary, M. W. Alexander, West Lynn, Mass.

**"Staybolts."**

This interesting monthly published by the Flannery Bolt Company, Pittsburgh, Pa., after an interesting presentation in the August issue of the installation of the Tate flexible staybolts in upright boilers, has an admirable essay on the locomotive and its service value, the underlying motive of the production being to show the vital importance of keeping the modern locomotive in service. It is indeed surprising when the percentage of actual time in service in twenty-four hours is carefully kept how much has been lost, and time is money. That the introduction of the flexible staybolt has greatly increased the working time of the modern locomotive is beyond controversy, and while this fact may not have been appreciated as fully as it should be, the growing popularity of the use of the flexible staybolt is the best proof that its merits as a time and money saver have not been overlooked. A perusal of the August issue will be of value to all interested, and copies may be had on application to the company's general offices, Vanadium Building, Pittsburgh, Pa.

**Car Heating and Lighting.**

The Safety Car Heating and Lighting Company, New York, has issued an illuminated map of the United States with adjacent portions of Canada and Mexico, showing the railroad lines having the company's electric lighting equipment in use, of which there are about 120 of the

leading roads. Constellations of stars show where the company maintains electric service supply stations, of which there are 62 spreading from San Antonio, Tex., in the south, to Revelstoke, British Columbia, in the north. Military posts, naval stations, light houses and light ships are also shown; the whole forming a graphic illustration of the far-reaching popular favor with which the enterprising company's fine products are being received on the continent of America. Apart from this special information the map is excellently printed, the cities and towns all being in capitals, easily distinguished. Copies of this fine map may be had on application at the company's office, 2 Recor street, New York.

**Summer in California**

"Summer in California" is the title of a new illustrated folder issued by the Salt Lake Route, which describes briefly some of the noted resorts and tells exactly why that southland with a warm winter climate is cool in summer. The six reasons given for this remarkable equability of climate are: latitude, the Pacific and its tonic winds, the local phenomenon of dynamic pressure squeezing humidity out of the air whenever the temperature rises, as one wrings a sponge, thus eliminating possibility of muggy, stifling weather; the familiar velo cloud of California regularly appearing a while in summer forenoons and screening off the sun's rays, the cool inward draughts of ocean air pouring eastward to replace the rising hot air of the deserts and interior valleys during the day, and the picturesque varied contour of Southern California with its mountains and valleys, foothills and passes, lying along the sea and inviting the air currents to constant activity. Some peaks are 11,000 feet high, and perpetually snow-capped. The article was written by Howard S. Nichols, of Los Angeles, and is handsomely illustrated.

**Hopper Door Mechanism.**

The United States Metal & Manufacturing Company, New York, has recently issued a folder descriptive of the Dunham hopper door device. The Dunham mechanism gives a positive lock. In locking, the oscillating point or upper link pin of the shaft arm passes beyond the pivotal point or point of support of the shaft arms, the door connecting links resting on a stop when the oscillating point has reached a given distance beyond the pivotal center. The resultant pull is hence below or beyond the point of support, and the greater the load applied to the doors the more positive the lock. The folder has half-tone and line illustrations showing the mechanism applied to gondola and self-clearing hopper cars. Copies of the folder may be had on application

**STEEL STAMPS**  
**INSPECTORS HAMMERS**  
 Hand Cut **STEEL LETTERS & FIGURES**  
**LATHE TOOLS, TIME CHECKS,**  
 Noble & Westbrook Mfg. Co.,  
 9 ASYLUM ST. HARTFORD, CONN.

**Locomotive Engine Running and Management**  
 By **ANGUS SINCLAIR**  
 This popular book has been a **RELIABLE REFERENCE** and comfortable unfailling **POCKET EDITION.**  
 PRICE, \$2.00  
**ANGUS SINCLAIR CO.**  
 114 Liberty St., New York

**Locomotive Electric Headlights**  
 of all descriptions  
**THE RAYLE-NATIONAL COMPANY** **TURBO GENERATOR SETS**  
 900 SOUTH MICHIGAN AVENUE CHICAGO, ILL.

**The Armstrong Automatic Drill Drift**  
 IS DRIFT AND HAMMER COMBINED.  
  
 The handle or driver is always ready to strike a blow as the spring automatically throws it back into position.  
**LEAVES ONE HAND FREE TO SAVE THE TOOL.**  
 Special Circular Mailed on Request.  
**ARMSTRONG BROS. TOOL COMPANY**  
 312 N. Francisco Ave., CHICAGO, U. S. A.

**ENAMELED IRON FLUSH OR DRY CLOSETS**  
**DUNER CAR CLOSETS**  
**DUNER CO.**  
 116 S. CLINTON ST., CHICAGO

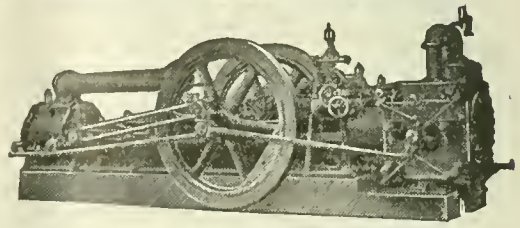

**The Norwalk Iron Works Co.**  
 SOUTH NORWALK, CONN.  
**Makers of Air and Gas Compressors**  
 For All Purposes  
 Send for Catalog



# Railway AND Locomotive Engineering

A Practical Journal of Motive Power, Rolling Stock and Appliances

Vol. XXIX.

114 Liberty Street, New York, October, 1916.

No. 10

## Fall of the Quebec Bridge

Canada's Great Engineering Project Set Back—Second Mishap in Ten Years—  
Theory of the Cause of the Failure of the Center Span—Strong  
Construction. But Accident Happened While Raising Span.

The news of the fall of the center or connecting span of the huge cantilever bridge at Quebec is now well known to all. There has not been that flood of "explanations" which one might have expected amid the great number of newspapers which printed accounts of the disaster. A possible exception is that of the explanation offered by Mr. H. Baker who saw the accident. In the absence of

planation there is no word of the connecting span having been too weak, nor anything at all to even suggest that the jacks failed in any way. In fact, it is fair to suppose that the design of the span was all that could be desired, because the motion pictures taken on the spot and other photographs show the span hanging from the ends of the cantilevers and in perfect condition. The jacks

end and 10 ft. at the south end before dinner, and the span hung securely during the hour that the men were off.

After the workmen returned one jacking (2-ft. lift) had been successfully taken at each end of the span. The span had been raised 10 and 12 ft. from the floating position. The top jacking pins were out, but the bottom jacking pins were in, and the jacking girder was descending for

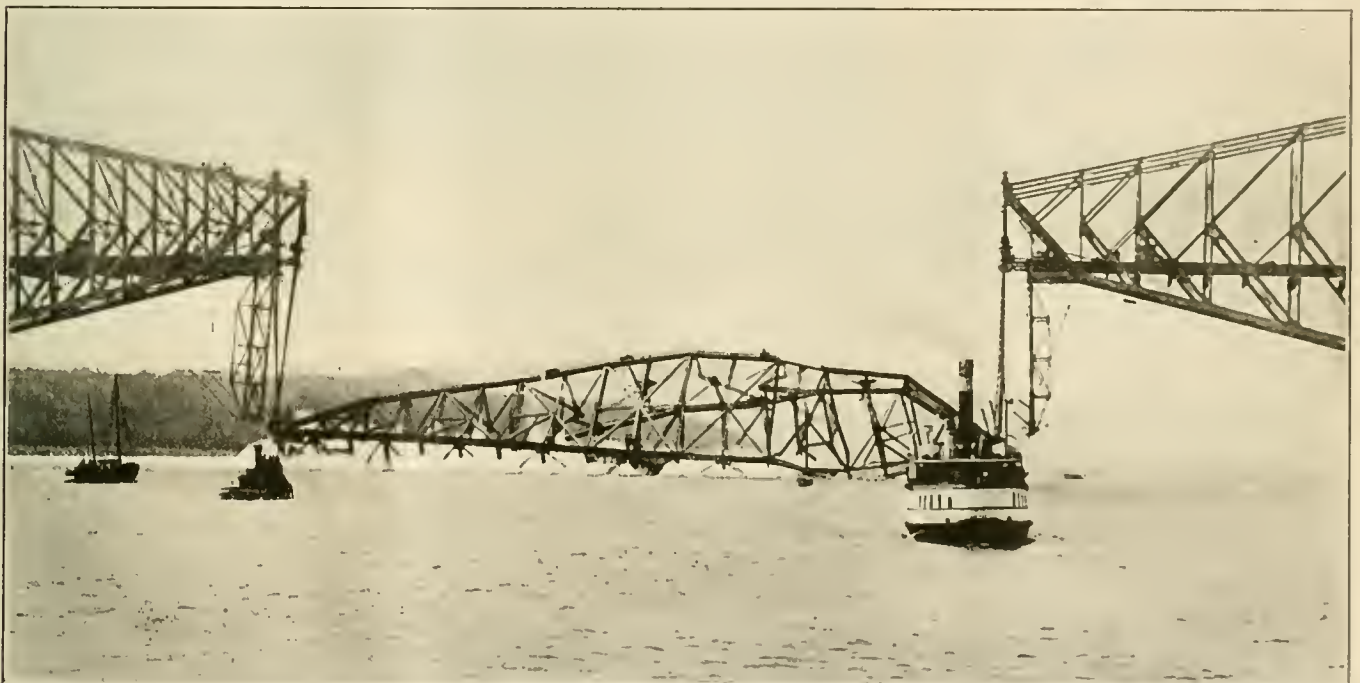

FALL OF THE CENTER SPAN OF THE QUEBEC BRIDGE. PHOTOGRAPH TAKEN AFTER ONE CORNER OF THE SPAN HAD SLIPPED. THE SPAN TORE OFF THE JACKING GIRDERS A CORNER AT A TIME, AND ROLLED OVER AS IT SUNK INTO THE RIVER.

more positive proof, it may be taken as one of the most likely theories of those which have so far been put forward. The theory in brief is that the span was not at a particular time securely fastened to the supports on which it was to rest, while the jacks, having been pushed up to their limit, were run down for another lift, during which time some part of the lifting mechanism failed. In this ex-

worked perfectly all through, and were intact after the accident.

After the tugs had hauled the pontoons clear, and the span hung on the ends of the cantilevers, the work of jacking was begun. Four lifts of two feet each had been taken on the north end, and five lifts of two feet each at the south end, when the workmen were allowed an hour for dinner. This means that the hanging span had been lifted 8 ft. at the north

another lift. In this position the center span was hanging from the lower or fixed jacking girders. Observers who were not on the bridge, but who were down-stream, off the south cantilever, are said by Mr. Baker in the *Engineering News* to agree that the south up-stream corner of the span in some way, or for some reason, slipped off the lifting girder.

As one corner slipped off first, it gave a corkscrew motion to the whole span

which rolled over as corner by corner it was torn away from the lower jacking girders. The span so unfortunately and inopportunistly set free from its supports was 640 ft. long, with level floor and bow-string top chord, 110 ft. high in the center, and 88 ft. wide. It had been built at Sillery Cove, three miles below the bridge site, and was there supported on barges floated under the structure when the tide was out. As the tide came in, the barges gently lifted the span, weighing about 5,000 tons, off the temporary supports, and transferred the whole weight to the barges.

The operation of floating the span under the gap between the cantilevers was accomplished by two tugs ahead, pulling the floating structure up stream at the time of incoming tide, and five tugs pulling gently backward helped to keep the span in position. A large sea-

between Nova Scotia and the west of Canada by 200 miles. Coming at a time when Canada's financial and industrial capacity is severely taxed by the strain of the great war, the disaster is specially unfortunate. The bridge failed in 1907, through inherent weakness of the structure, and though now a failure in the process of placing the center span or a slip of the supporting connections may be the underlying cause, yet the deplorable loss of life which has taken place outweighs all considerations of a financial nature. A careful government inquiry is to be undertaken at once. The strain upon the cantilevers caused by the twisting fall of the connecting span has so far proved that they have been well and securely built. There was no splash when the span fell and no wave surged out from the twisted steel work as it

or express matter being loaded in the end of the car; the floors are fitted with hardwood strips, instead of "fish-racks," as being more readily kept clean, especially when the car is used for carrying shipments of fish.

#### Motive Power Department Meetings of the Baltimore and Ohio.

The motive power officials of the Baltimore and Ohio have instituted a system of staff meetings at the general offices of the company for the discussion of subjects pertaining to the efficiency of locomotives and cars, and shop operations. Mr. F. H. Clark, general superintendent of motive power is in charge. Mr. M. K. Barnum, Baltimore, and Mr. M. J. McCarthy, Cincinnati, district superintendents of motive power, the general master mechanics, and the master mechanics at the seventeen repair shops, besides motive



MAP SHOWING POSITION OF THE QUEBEC BRIDGE AND SILLERY COVE THREE MILES BELOW BRIDGE, WHERE CENTER SPAN WAS BUILT.

going tug "stood by," in case of necessity. When connections by means of the hanger chains were made, the fall of the tide caused the weight of the span to become less and less upon the barges and the first lift of the jacks allowed the barges to be withdrawn, and the span hung clear over the water directly below its final position, connecting the cantilevers.

As far back as 1853 bridge plans were first considered, and in 1882 the cantilever form of bridge was decided upon and replaced the original conception. When finally approved, a structure 3,239 ft. from shore to shore, 150 ft. above the water line, and costing about \$17,000,000, was to be the bridge in its final form, as we know it. When completed it will carry the traffic of eight railway lines, and shorten the distance

rolled over and settled out of sight below the surface of the water. The fall occupied only seven seconds and the work of months was thus quickly swallowed up beneath the sullen stream.

#### Canadian Steel-Frame Baggage Cars.

The Intercolonial Railway shops in Moncton has recently completed four steel-frame baggage cars, the first of their kind to be built at these works. The cars have solid steel trucks so designed that the wheels can be changed quickly with a minimum amount of labor. The draft gear is constructed to absorb shock in starting and stopping, and is of sufficient strength to withstand the heaviest type of engine. Westinghouse brakes of the latest pattern are used. The side doors are brought closer together than in ordinary cars to permit of through baggage

power and boiler inspectors, district master car builders and the road foremen of engines are all interested in the meetings. Detailed records of the performance of each engine under varying conditions are kept and the repair costs and fuel expense per mile relating to the moving traffic are considered, and a higher degree of efficiency cannot fail to result from these staff meetings.

#### Change of Name.

The San Pedro, Los Angeles & Salt Lake Railroad Company has changed its name to that of Los Angeles & Salt Lake Railroad Company. The designation used in tariffs, circulars, advertising matters, tickets and other matter of a general kind will continue as formerly to be known as the Salt Lake Route.

# Oakland, Antioch and Eastern Car Ferry "Ramon"

Heavy Traffic Handled by Electric Equipment. Gasoline Used for Propelling the Ferry and Generating Current for Overhead Trolley Wire on the Boat

Seven electric trains run daily between Oakland and Sacramento, Cal., on the Oakland, Antioch and Eastern railway, which with two seven mile branches, one to Antioch and the other to Danville,

feet long, and weighs 590 tons. It is driven by a 600 horse power, eight cylinder, gasoline engine of the electric ignition type, and usually carries six loaded passenger cars or eight freight cars. The

date nine cars. As will be noted in the illustration, there is an overhead catenary construction so that the trains are able to run off the ferry under their own power.

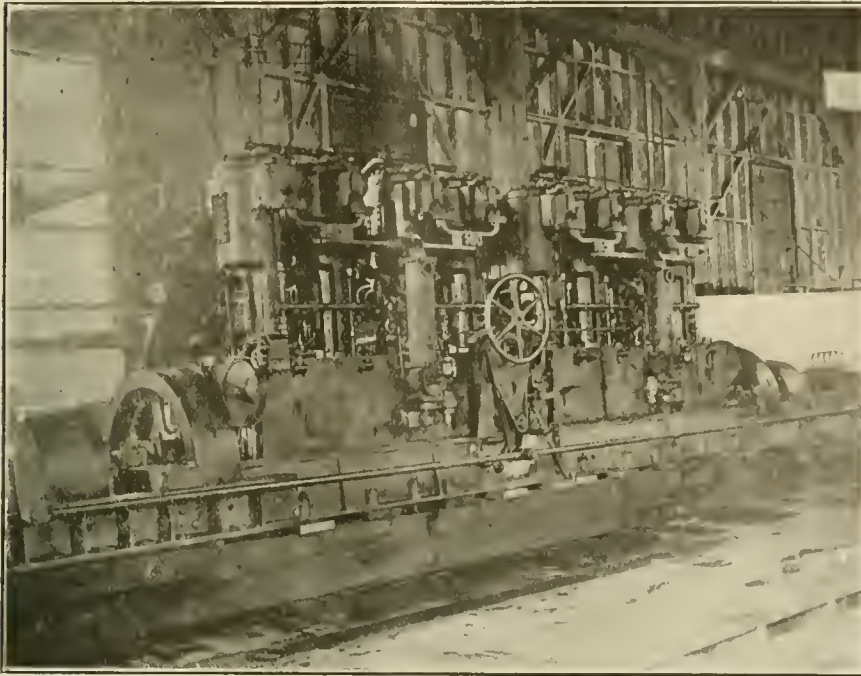

SIX HUNDRED HORSE POWER, EIGHT CYLINDER GASOLINE ENGINE, CAR FERRY, OAKLAND, ANTIOCH AND EASTERN RAILWAY COMPANY.

make a total of 150 miles. In crossing Suisun Bay, the railway transports its trains across the bay from Bay Point to Chipps Island. A bridge 10,000 feet long and 70 feet high will be constructed over

engine is said to be the largest of its kind ever built, weighing approximately 120,000 pounds. It is set amidships and is coupled to a propeller at each end through piston clutches. The two propellers are

On the railroad the trains are hauled by high speed electric locomotives. All the electrical equipment, including that for cars, locomotives, sub-stations and line material, were furnished by the Westinghouse Electric & Mfg. Company, of East Pittsburgh, Pa. The railway operates eighteen standard motor passenger cars and several palatial parlor cars and coaches. The standard cars are 56 feet long, weight 87,300 pounds each and are divided into express, main passenger and smoking compartments. The parlor cars, which are hauled on express trains have a buffet and seat sixty persons. They are fitted up with appointments equal in every way to parlor cars operated by steam railroads and thus the system offers as complete comfort to the traveler as can be secured on competing steam lines, with the added comfort of freedom from smoke, etc. Each motor car is equipped with four Westinghouse 120 horsepower, 600-1,200 volt commutating pole motors, and 1,200 volt 11L control.

Since the opening of the road the passenger traffic between Oakland and Sacramento has increased so rapidly that in order to meet the demands it has been necessary to supplement the multiple unit trains and cars by electric locomotive hauled trains composed of standard passenger coaches. For this purpose four articulating truck, high speed, 62-ton Baldwin-



CAR FERRY "RAMON," OAKLAND, ANTIOCH AND EASTERN RAILWAY COMPANY.

this bay. Meanwhile the cars with passengers aboard are ferried across so that no change of cars is necessary. The car ferry is known as the "Ramon," and is constructed entirely of steel. It is 185

of opposite pitch and the direction of the boat is controlled by engaging either one clutch or the other, thus avoiding reversing. There are three tracks on the main deck, each 220 feet long, and can accomo-

Westinghouse electric locomotives are employed. Each is equipped with four 250 horsepower, 600-1,200 volt, commutating pole motors, geared 24:47 with 42-inch wheels, giving a maximum permissi-

ble speed of 70 miles per hour. These locomotives are able to haul five steel, 37½-ton coaches on a level tangent track with 1,100 volts on the trolley, at a balancing speed of 50 miles per hour. HL control mounted in the center of each locomotive cab controls the power to the motors. The use of electric locomotives on an interurban road in this manner is a new and noteworthy application in the electric railway field.

In addition to the passenger traffic, the railway also handles through and local freight between Oakland and Sacramento. For this traffic two 47-ton, slow speed, Baldwin-Westinghouse electric locomotives are used, of the steel cab type with swivel trucks, and equipped with four 120 horsepower 600-1,200 volt commutating pole motors and HL control. The schedule of the road calls for a speed of 65 miles per hour on through passenger trains. The stops of limited trains number but three in 85 miles, and on local trains there are two stops to the mile.

#### Pulverized Coal for Locomotives.

The International Railway Fuel Association, through an able committee having charge of the subject of pulverized coal for locomotives, briefly summarizes its advantages in being smokeless and free from cinders; in maintaining a maximum boiler pressure with a uniform variation of three pounds, thereby avoiding loss at the safety valves; an increase of from 7 to 15 per cent. in boiler efficiency as compared with lump coal; a saving of from 15 to 30 per cent. in fuel of equal heat value fired; enlarged exhaust nozzle area with consequent greater drawbar pull and easier running of the locomotive; elimination of ashpit delays; reduction of time and greater ease in firing up; maintenance of a relatively higher degree of superheat steam; in no accumulation of matter in flues; no overheating of firebox; elimination of manual labor for building, cleaning and dumping fires, besides avoiding expense in providing various sizes and kinds of fuel, and also eliminating front end and ash pan inspection and the use of many special tools. The committee is of opinion that the marked advantages of the use of pulverized coal has been amply demonstrated, and that progress in this method of stoking will be rapid. Plants are being already established in the United States, and many countries are considering the use of pulverized coal in locomotives. In stationary practice it has been already demonstrated that the power for pulverizing and feeding the fuel does not exceed 3 per cent. of the boiler capacity, and in larger quantities in locomotive plants this is being reduced, and further reductions may be expected.

## Hoosac Tunnel Electric Locomotives

### Increased Capacity of Tunnel Secured—Congestion at Each Portal Eliminated—Efficiency of Motors—Absence of Smoke—Curious Mishaps of Former Days

The Hoosac tunnel of the Boston & Maine railroad is the largest electrified tunnel in America. The work of constructing the tunnel was begun in 1851, and completed in time for the first steam train to pass through it on February 9, 1875. It is 25,081 feet long and is double tracked throughout. Until its electrification in 1911 it was always an obstructing feature to the traffic of this railroad. Under steam operation the entire tunnel was a block, only one train at a time being allowed to pass through. Under electric operation several trains are permitted in the tunnel. The electrification, which is of the Westinghouse single phase system, has been entirely successful in operation, proven by the ease with which the heavy freight traffic of the road has been handled. Freight trains are no longer

sisting of two pairs of 63-inch drivers and a pair of pony wheels 42 inches in diameter. Each locomotive has four, 375 horse-power, Westinghouse, single phase motors of the series commutating type, with short circuited auxiliary field windings. The gears on the locomotive are of the flexible type, which minimize vibration and prevent any strains or shocks on the teeth of the gears, also aiding the motors to start under very heavy loads.

In electrifying this system the crossing of the 600-volt lines of the city railway by the 11,000-volt single catenary construction of the Boston & Maine was accomplished. This was one of the many interesting engineering features encountered in the installation of the overhead construction, all of which was furnished by the Westinghouse Company.

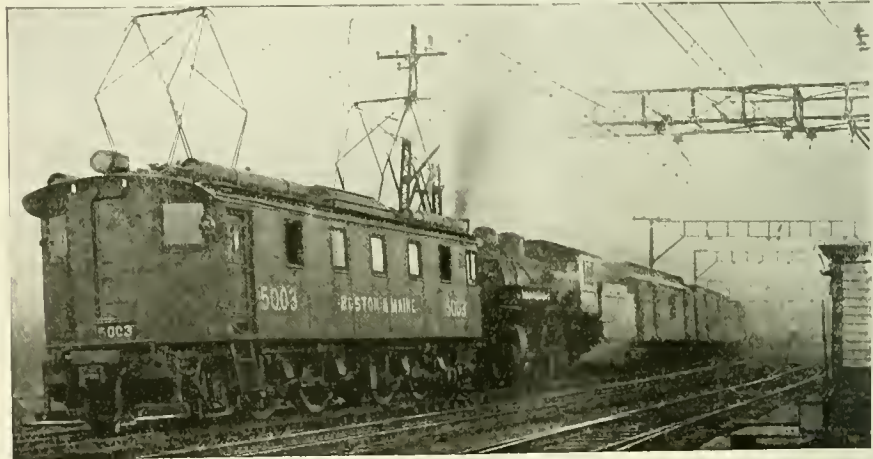

ELECTRIC LOCOMOTIVE ON THE BOSTON & MAINE RAILROAD.

packed three or four deep at each portal waiting for a chance to get through.

As many as 77 trains a day pass through the tunnel and regularly 71 trains pass through every 24 hours. Of these about 17 are passenger trains, the remainder freight. Up to the present time the entire traffic through this tunnel has been handled by five Baldwin-Westinghouse, 130-ton, 11,000 volt, single phase electric locomotives. Traffic, however, has increased to such an extent that it has become necessary to supplement the present equipment. Due to the great success achieved by the electric locomotives already in service, the Boston & Maine have placed an order with the Westinghouse Electric & Mfg. Company of East Pittsburgh, Pa., for two additional 130-ton Baldwin-Westinghouse electric locomotives similar to the five now operating, of which the one illustrated is typical.

The locomotives have but one cab, with two articulated trucks, each truck con-

We have the authority of a former official of the B. & M. for the statement that at times the smoke in the tunnel became so dense that he has observed a fireman feel with his broom against the tunnel wall to ascertain that the train was actually moving ahead. On one occasion a heavy freight train became stalled, but the driving wheels continued to revolve, and the engineman, thinking that he was progressing, did not shut off, and the "broom test" for motion was not applied by the fireman. The result was that the stalled train blocked traffic and the tires of the wheels became hot and eventually loosened sufficiently to come off, and the rails upon which the engine stood were ruined. The story told by the engineman that he expected to be out of the tunnel in due time, as the engine kept working, appeared to the officials to be so fantastic that the man was relieved of further duty on the road, although what he said was true.

# Santa Fe Type Locomotive For the Erie

Most Powerful Type of Non-articulated Locomotive Yet Built—Equipped With Hanna Stoker and Baker Valve Gear

In 1915, the Baldwin Locomotive Works built an experimental locomotive of the 2-10-2 type for the Erie R. R. This engine proved successful; and its design was used as a basis for that of twenty others, which are now in service. One of the most recent of these, No. 4038, is shown in the accompanying illustration.

The original locomotive had an extended wagon-top boiler. In the new design, the firebox dimensions and the number and arrangement of the tubes are the same as in the first engine, but the boiler shell is straight, the diameter at the front end being increased from 90 to 96¼ ins. This provides additional steam space, and somewhat increases the total weight.

All these locomotives exert a tractive force of about 83,000 lbs. The original engine, and ten of the more recent ones,

lugs for spring rigging and other purposes. The holes for the larger bolts and pins are fitted with bushings of cold drawn steel tubing. The frame cradle is securely bolted to the main frames, immediately back of the rear driving pedestals.

These locomotives have plain tires on the main or third pair of driving wheels, and greater lateral play is allowed between the rails and flanges on the first and fifth pairs of wheels than on the second and fourth pairs. This construction, in conjunction with the use of flange oilers, reduces flange friction when traversing sharp curves. The leading truck is of the "Economy" constant resistance type. It is equalized with the first and second pairs of driving wheels, while the three remaining pairs are equalized with the rear truck.

The Baker valve gear is applied, and

superheater, brick arches, mechanical stokers, and power operated grate shakers and reverse gears, represent the most powerful type of non-articulated locomotive thus far built. The principal dimensions of this type of locomotive are as follows:

Gauge, 4 ft. 8½ ins.; cylinders, 31 x 32 ins.; valves, piston, 16 ins. diameter.

Boiler—Type, straight; diameter, 96¼ ins.; thickness of sheets, 15/16 in.; working pressure, 200 lbs.; fuel, soft coal; staying, radial.

Firebox—Material, steel; length, 132 ins.; width, 96 ins.; depth, front, 89½ ins.; back, 75½ ins.; thickness of sheets, sides, ⅜ in.; back, ⅜ in.; crown, ⅜ in.; tube, ⅝ in.

Water space—Front, 6 ins.; sides, 6 ins.; back, 6 ins.

Tubes—Diameter, 5½ and 2¼ ins.; material, steel; thickness, 5½-in., 0.150

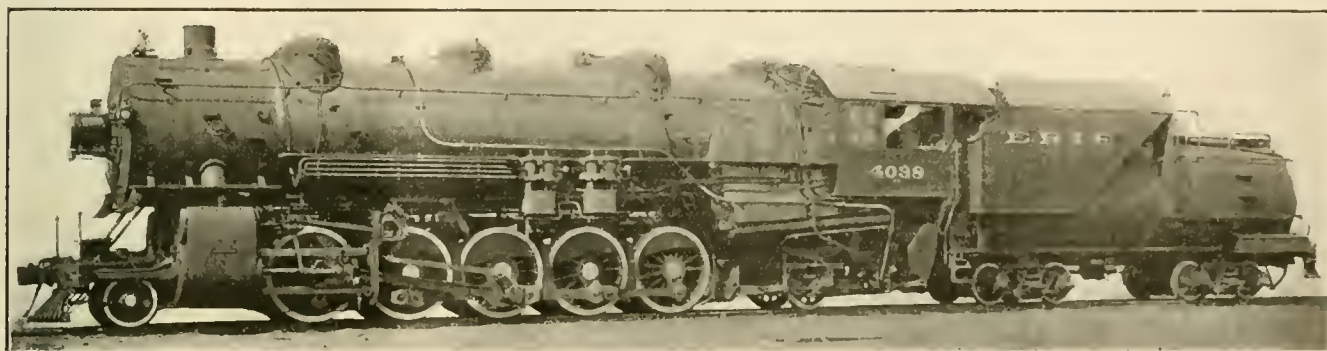

2-10-2 TYPE LOCOMOTIVE FOR THE ERIE RAILROAD.

Wm. Schlafge, Gen. Mech. Supt.,

Baldwin Locomotive Works, Builders.

are equipped with Street stokers; while the last ten, including the 4038, are fitted with Hanna stokers. The engines have a large number of interchangeable details, and constitute a notable group of heavy motive power units.

The firebox, in this design, is placed back of the driving wheels and over the rear truck, and has a combustion chamber 28 ins. long. The crown and sides of the firebox are in one piece with the combustion chamber, and the seam on the bottom center line of this chamber is electrically welded. The tubes are welded into the back tube-sheet. Access to the interior of the boiler is obtained through a 16-in. opening under the auxiliary dome.

The main frames are vanadium steel castings, 6 ins. wide, spaced 42 ins. between centers. The Commonwealth Steel Company's back frame cradle is applied. This cradle combines, in one casting, the two rear frames, back foot plate, back truck radius bar cross-tie, equalizing beam fulcrums, and various

is controlled by the Ragonnet power reverse mechanism. The cross-head link, through which the combining lever is driven, is pinned directly to the cross-head wrist pin. This construction simplifies the design and saves weight, and has been applied to a number of recent locomotives.

In order to provide sufficient capacity without exceeding the clearance limitations, four sand boxes are used, and they are placed right and left on top of the boiler, two for running ahead and two for backing up. The bell is placed on the smoke-box, in front of the stack. The general arrangement results in a neat outline, which is often difficult to secure, especially in a locomotive as large as this one.

The tender is of the Vanderbilt type, with capacity for 10,000 gallons of water and 24 tons of coal. This style of tender has been applied to all the road engines recently built for the Erie.

These locomotives, equipped with such fuel and labor saving devices as

in.; 2¼-in., 0.125 in.; number, 5½-in., 48; 2¼-in., 259; length, 24 ft.

Heating surface—Firebox, 258 sq. ft.; combustion chamber, 63 sq. ft.; tubes, 5,302 sq. ft.; firebrick tubes, 37 sq. ft.; total, 5,660 sq. ft.; superheater, 1,389 sq. ft.; grate area, 88 sq. ft.

Driving wheels—Diameter, outside, 63 ins.; center, 56 ins.; journals, main, 13 x 22 ins.; others, 11 x 13 1/16 ins.

Engine truck wheels—Diameter, front, 33 ins.; journals, 6 x 12 ins.; diameter, back, 42 ins.; journals, 9 x 14 ins.

Wheel base—Driving, 22 ft.; rigid, 22 ft.; total engine, 41 ft. 5 ins.; total engine and tender, 78 ft. 4½ ins.

Weight—On driving wheels, 337,400 lbs.; on truck, front, 25,300 lbs.; back, 54,500 lbs.; total engine, 417,200 lbs.; total engine and tender, about 612,000 lbs.

Tender—Wheels, number, 8; diameter, 33 ins.; journals, 6 x 11 ins.; tank capacity, 10,000 gals.; fuel, 24 tons, service, freight.

# Superheater Performance on Locomotives

## The Statement of the Case—What Superheating Actually Means—The Various Economies Resulting From Superheating Steam—Their Monetary Value—Result of Test on the New York, Ontario and Western Railway

The essential, or underlying cause of the undoubtedly satisfactory performance of superheater locomotives has been epitomized in the generally true statement that the difference between superheated and saturated steam is the difference between using an approximately perfect, expansible gas and using what is practically high-pressure fog.

The reason for this comparison is that in any cylinder there is bound to be a tendency toward condensation, and saturated steam is just at the point where it readily turns to water. Under these circumstances steam, at the saturation or dew point, when it comes in contact with the comparatively cool walls of a cylinder, condenses. The water of condensation is thrown out of the stack, having done no useful work. It has, however, required the burning of coal to heat it up to boiling temperature and to change its physical state. This fact constitutes a very serious loss of heat and power. As

engines, and these losses were consequently among the limiting factors in cylinder diameters before the adoption of the superheater.

Superheated steam carries in it sufficient extra heat to meet the inevitable heat losses to which it is exposed in the cylinders and in the passages through the valves and steam pipes to them. Saturated steam, as intimated, suffers from these losses by a change in its physical state, i. e., by a change from steam to water, while superheated steam has a sufficient amount of reserve heat, above the condensation point, to prevent it at once turning to water, and it is thus able to exert its full power during expansion.

The laws of nature are unalterable, and the generation of superheated steam follows definite and fixed laws. Nature demands that everything obtained must be paid for, and following this law superheated steam is not to be had for nothing, but because it saves many times more

work as that done by saturated steam, is the decrease in weight per unit of volume of the former. In other words, a cylinder full of saturated steam weighs more than a cylinder full of superheated steam, and the same cylinder full of superheated steam will do practically the same amount of work as a cylinder full of saturated steam. Steam is generated from water on what may be considered a weight basis, and it is used in the cylinders on a volume basis. Since the same volume of superheated steam weighs less than saturated steam, the weight of superheated steam generated to produce the same power is less than saturated steam.

As was pointed out above, the fact that the economy of superheated steam is greater than that of saturated steam, has the effect of increasing the capacity of the locomotive, which means that more cars may be pulled or faster schedules maintained with the superheated engine at a lower cost than is possible with a

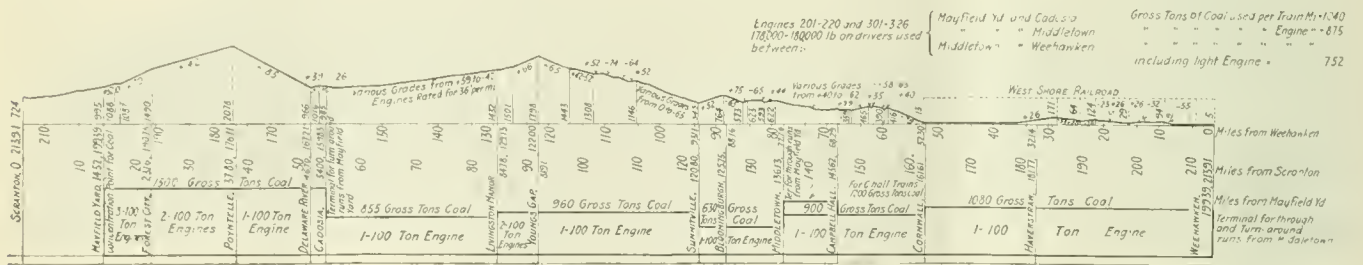

PROFILE OF THE NEW YORK, ONTARIO & WESTERN RAILWAY FROM WEEILAWKEN, N. J., TO SCRANTON, PA.

much as 35 to 50 per cent of the water supplied to the boiler is expelled, hot, yet without having produced anything like the work that was required of it.

Those who are familiar, by use, with superheater engines, say that the engine-men look upon them as machines in which the steam supply is sure. Those who operate them find that they are able to work them harder; that is, they can operate them at higher speeds and at longer cut-off, and this results in hauling heavier trains. Under these conditions the old problems encountered in the operation of saturated steam engines, of trading water for steam, is no longer a factor to be considered.

The use of larger cylinders and lower boiler pressures has been made possible by the introduction of superheated steam, and there is a resultant reduction in boiler maintenance cost. Larger cylinders, of course, afford larger radiating surfaces which tend to increase the condensation losses in saturated steam

than it costs to produce (by the elimination of cylinder condensation and other losses incident to cylinder condensation), it is economical in locomotive performance. Part of the heat liberated by the coal burned in the firebox is used in obtaining superheated steam. Because of the fact that superheated steam is able to fully expand, it does its work more perfectly than saturated steam does, and as a result, less is used and less is needed. In other words, more of the energy stored up in the fuel is converted into useful work, and the same work is obtained with less fuel. In addition to this, since the grate is capable of burning the same amount of fuel with a superheated engine as is burned in the case of a saturated steam engine, and the boiler is capable of evaporating nearly as much in the former as in the latter case, the capacity of the locomotive is increased.

Another factor which has its influence on the reduction in quantity by weight of superheated steam used to do the same

saturated engine. Faster schedules, of course, imply the shortening of the time on the road, and this carries with it the operating advantage that the engine is available for a return trip earlier than it otherwise would be. This points to the fact that it will actually mean that fewer engines are required to do the business of the road. Longer trains, with faster schedules, have the same effect upon the number of engines required to handle a given amount of traffic, and when the traffic of a road, with saturated engines, has reached the limit of its full capacity, it has the effect of increasing the capacity of the road without extending the track-age.

When this principle is applied in switching service it has the advantage of increasing the yard capacity without adding tracks or locomotives which, beyond a certain point, tend to restrict rather than expand the capacity of the yard. Every engine added in a yard requires a certain amount of free space in which it may

move about. This space could readily be used for the storage or movement of cars. The congestion of crowded city yards, where the securing of additional trackage is physically impossible, often can be relieved by superheating the switch engines working on the job. Not infrequently it is found that existing traffic conditions of a given yard, together with increases possible by the elimination of one or more of the switch engines, can be handled by four superheated locomotives in place of five saturated. The burning of less coal extends the time between fire cleanings and gains working time or places more engine hours per engine

mile, while it represents a large saving to the railroad in dollars and cents, and possibly offers the most tangible source from which to obtain definite figures, are in fact the smallest among the benefits secured from superheating, and are not comparable with the more important one of increase in ton-miles hauled per unit of time, as this represents the increased output with the same or reduced operating charges, and is, therefore, a net revenue added to the railroad income. Consequently, like the so-called process of "dumping" the over-production of a commercial plant, the revenue goes direct to the stockholders' dividends, without the

dive. The record was from a carefully conducted test made on that road, and forms a ready and reliable set of figures, by which comparisons may be made. Mr. Flory has thus been able to give to the science of locomotive operation data of the greatest possible value to railroad men who are vitally concerned in economical and efficient locomotive performance.

**Hardened Steel.**

We do not like the expression, "hard as fire and water can make it," used popularly in connection with the hardening of steel, for it generally means that

**NEW YORK, ONTARIO & WESTERN RAILWAY**

Middletown, 6-24-14.

E. Newhall, Engineer.  
W. Mulligan, Fireman.

**COMPARISON BETWEEN SUPERHEATER (213) AND SATURATED STEAM (216)**

ENGINE 213.																				
Date, 1914.	Trip No.	Train No.	Time leaving.	Time arriving.	Time on road.	Actual running time.	Miles per hour.	Number of stops.	Number of cars (max.).	Weight of load (tons) max.	Tons hauled one mile (without loco.).	Weight of train ton-miles (with-out loco.).	Water used (gallons).	Average steam pressure.	Coal used (lbs.).					
6-8-14	1	Ex.	12.06	2.43	2.37	1.31	....	6	34	1,976	51,276	1,976	1,772	....	....	To Cornwall.				
6-8-14	..	Ex.	3.56	5.43	1.47	1.43	....	6	43	769	19,994	769	3,546	....	10,675	Cornwall to Middletown.				
<b>Totals</b> .....													....	10,675	.....					
ENGINE 216.																				
6-13-14	2	Ex.	7.28	9.45	2.17	1.43	....	5	37	1,625	42,250	1,625	3,100	....	....	To Cornwall.				
6-13-14	..	Ex.	11.04	1.00	1.56	1.44	....	3	36	644	16,744	644	5,100	....	10,000	Cornwall to Middletown.				
<b>Totals</b> .....													....	10,000	.....					
ENGINE 216—Middletown to Mayfield and return.																				
6-16-14	3	Ex.	5.13 a.m.	4.45 p.m.	11.32	8.07	15	14	37	650	88,917	505	21,480	196	20,640	.....				
6-17-14	4	Ex.	3.21 a.m.	2.38 p.m.	11.17	9.17	13	12	26	1,473	165,650	1,096	21,650	197	27,590	.....				
6-18-14	5	Ex.	5.19 a.m.	3.27 p.m.	10.8	7.56	15.4	9	47	808	90,496	751	19,869	196	24,634	No pusher Cadosia to Poyntelle.				
6-19-14	6	Ex.	2.58 a.m.	2.34 p.m.	11.36	9.10	13.3	8	28	1,446	176,666	1,285	21,589	195	27,909	.....				
<b>Average</b> .....													....	25,193	.....					
ENGINE 213—Middletown to Mayfield Yard and return.																				
6-20-14	7	Ex.	9.56 a.m.	9.03 p.m.	11.7	7.47	15.7	13	54	965	119,188	873	13,739	185	19,800	.....				
6-21-14	8	Ex.	7.25 a.m.	5.52 p.m.	10.27	8.03	15.2	8	34	1,746	204,191	1,491	14,847	186	20,127	.....				
6-23-14	9	Ex.	9.24 a.m.	8.32 p.m.	11.8	7.38	15.6	8	52	951	120,460	859	14,182	186	18,408	.....				
6-24-14	10	Ex.	1.29 p.m.	12.33 a.m.	11.4	8.41	14	8	31	1,739	200,925	1,477	13,387	186	20,306	.....				
<b>Average</b> .....													....	19,659	.....					
Results between Middletown and Mayfield.																				
										Superheater No. 213	Saturated No. 216									
										78,635	100,773	....								
										467,958	705,118	....								
										5.9	6.9	....								
										Average number tons hauled one mile (per trip of 122 miles).....										
										161,191	130,432	....								
A										1,175	934	20½%								
B										0.122	0.193	37%								
										0.01024	0.01622	....								
C										16.51	21.16	22%								
										0.725	1.351	46%								
On trip to Cornwall percentages of A, B and C are 17%, 13% and 46%, respectively.																				
													216		213					
													Trip 3 and 4		Trip 5 and 6		Trip 7 and 8		Trip 9 and 10	
													16		20		26		25	
													2.20		2.50		2.32		2.21	
													2.03		1.36		1.51		1.36	
													1.20		1.15		1.15		.58	
													1.31		1.19		1.18		1.43	
													*2.17		*2.04		1.26		1.41	
													.44		*1.01		.47		.53	
													27		26		25		28	
													*Train in block.							

every day at the disposal of the railroad company. Less water being used, there are fewer runs to the tank, conserving the time of the engine and the switching crew, which would otherwise be idle during this movement. The reduction of water consumption means less to pump or a smaller payment to the city water-works department.

The whole trend of the superheated steam movement makes for economy, not only from a purely scientific, but from practical and financial standpoints as well. In fact, the coal and water saved per ton

deductions that apply to the regular output.

A switch engine less within city limits means one less "smoke-producer" to be accounted for to the smoke abatement department of civic supervision, and is what Jim Skeevers would have called an "object lesson" on all round economy.

Through the courtesy of Mr. B. P. Flory, Superintendent of Motive Power of the New York, Ontario & Western Railway, we are able to append the record of the performance of a superheated and a saturated steam locomotive.

the steel is to be made coarse by over-heating. It cannot be impressed too often upon the steel worker that his aim should be to refine the grain so that it will disappear when viewed by the unaided eye; the hardness will take care of itself. If it is not hard enough when refined by hardening at low heat, then the steel itself is too mild. Better take the steelmaker into your confidence and tell him what you want the steel to do. Then he will give you what will refine to a strong condition and harden just right for your purpose.

# Convention of General Foremen's Association

## Summary of Work Done at Twelfth Annual Convention— Reports and Discussions Thereof

The twelfth annual convention of the International Railway General Foremen's Association was held in Hotel Sherman, Chicago, beginning on Tuesday, August 24, and continuing over four days. President L. A. North presided. After a prayer by Dr. Sunsaulus, and welcoming remarks by Daniel Webster, a city official, President North made his inaugural address. He said in part:

This association was formed for educational purposes and throughout the whole of its history the educational idea has never been ignored and has been strongly influenced in the selection of subjects for investigation and discussion. He urged the members in the discussions to bring out the points which are likely to be useful and of value in the handling of men and materials. He urged the application of the Golden Rule, not simply because the men, as individuals, deserve such consideration, but because such action is calculated to be productive of the greatest returns to the company they work for. It is well to keep before the members of the association the idea that their advancement and promotion depends upon their ability to look ahead and prepare for the future. As general foremen, he said, you are leaders and the examples you set will largely govern the actions of your subordinates. By using tact and good judgment you can secure their loyalty and hearty co-operation.

Secretary-Treasurer Hall then read his annual report which showed the present membership of the association to be 229 and the finances to be in a satisfactory condition. He mentioned that there existed a widespread demand for the proceedings of the association, requests for copies having been received from Bolivia, Japan, Peru, South Africa and Manchester, England.

After the appointment of the temporary committees, President North called upon Dr. Angus Sinclair for some remarks. In response Dr. Sinclair related some of his own experiences as a shopman and as a shop foreman. He told of his experiences with a hard drinking boiler patcher to whom he was engaged as helper. This man took great delight in asking questions intended to test the observing habits of his helper. He expressed the belief that this training with habits of observation has contributed largely to his success in life. He urged the foremen present to adopt a similar practice with their apprentices.

ADDRESS OF CHIEF BOILER INSPECTOR  
MCMANAMY.

Wednesday morning was devoted to an

address from Frank McManamy, chief boiler inspector of the Interstate Commerce Commission. He gave some particulars about the locomotive boiler inspection law. This law, which went into operation in March, 1915, requires locomotives to be maintained in proper condition and safe to operate. The rules are specific and definitely fix the responsibility for the performance of certain tests, inspections and repairs. Mr. McManamy gave detailed information to foremen in charge of locomotives concerning their duties under the law, to insure an inspection of each locomotive at certain prescribed periods, and second the requirements that the foreman in charge to know the condition of each locomotive, and to



L. A. NORTH.

say why defects reported were not executed before the engine was returned to service.

If the foreman uses the report as was intended and makes it show the exact reason why repairs were not made, the responsibility will be placed where it belongs. If proper material is not provided, or if the appropriation is exhausted, or if the transportation department refuses to let him hold the locomotive, that fact should be noted on the report so that it may be considered in determining the reason why the repairs were not made.

Advice was then given of certain parts that required special attention as they are more likely to cause accidents through breakage. We are unable to devote space to the whole of Mr. McManamy's remarks and we recommend foremen and others to study them carefully in the annual report which will soon appear.

### CAR DEPARTMENT PROBLEMS.

The above was the title of a report submitted by E. E. Greise, master mechanic of the Pennsylvania Line, who said that there are operating today in the United States two million freight cars, the cost of maintenance of each being from \$80 to \$100 a year. Assuming \$90 as an average, the total expenditure in the United States for repairs and inspections is about \$180,000,000 a year. A recent comparison made of locomotive to car repairs made the maintenance of locomotives 60 per cent. and cars 40 per cent. Although car work is rougher than on locomotives it can be performed largely by unskilled labor. About 20 per cent. of the money spent on car repairs is used up in repairing foreign cars. This enormous sum of money is exchanged between railroads without any definite means of checking against the work performed by repairing lines. It will be realized that the repairing of foreign cars and billing on repairs occupies a unique position in business. There is perhaps no other line of business where such large sums of money are exchanged on the basis of common honesty. To safeguard car owners two things are necessary; first, adequate supervision; second, a thorough, efficient system of preparing original records and computing charges from such records.

*Training of Car Inspectors.*—A strong plea was made for the employing of efficient car inspectors. A man should only be promoted to the position of car inspector who has gone through proper training. A car inspector must be able to detect the parts which have actually broken down and defects which may develop with subsequent failures.

*Car Apprentices.*—The apprentice system in the car department on some roads has declined to a point where few apprentices are enrolled. Mr. Griest made a strong plea for the introduction of an efficient apprentice system which should provide for:

1. A sufficient amount of time spent in each department to give the apprentice a clear idea of that part of the work.
2. A rate of pay which would attract boys of some education.
3. Promotion for the better grade of apprentices.

The discussion that followed the reading of this paper indicated a growing appreciation on the part of locomotive foremen for the duties done by the men connected with the car department. It was pointed out that the work of the car department not only involves the actual work of repairing cars, but also requires



a knowledge of the Master Car Builders' rules, the safety appliance standard; rules for loading material, etc., about all of which the general foreman should acquire some knowledge.

The opinion was expressed that sufficient interest had not been taken in car department apprentices. A car apprentice system is needed to develop men for efficient foremen of this department.

The causes of hot-boxes were given under six headings and valuable suggestions advanced for prevention of the trouble.

#### LOCOMOTIVE COUNTERBALANCING.

This ancient and troublesome subject was ventilated by H. E. Warner, general foreman, New York Central Lines, Elkhart, Ind., who held that the almost exact balancing of the locomotive of today was due to the labors of past railway mechanical engineers. He held that the counterbalance in the wheels must be equivalent to all the revolving parts and a portion of the reciprocating parts. The greater proportion of reciprocating parts that are counterbalanced, the smaller will be the longitudinal motion of the engine, but the greater will be the vertical disturbance. This unbalanced vertical component causes the pressure of the drivers on the rail to vary with each revolution, causing what is known as the "hammer blow." If too little of the reciprocating parts are counterbalanced there will be excessive longitudinal motion of the engine.

Particulars were given of many experiments carried out on the counterbalancing of locomotive driving wheels, some of them being accompanied by good illustrations.

The discussion which followed the reading of this report indicated that there is still considerable diversity in the practice of counterbalancing. Some railroads follow the rule established by the Master Mechanics' Association while others adhere to rules of their own.

#### CLASSIFICATION OF LOCOMOTIVE REPAIRS.

A report on this subject was prepared by C. S. Williams, shop superintendent of the Pere Marquette, who dealt with the subject exhaustively, minute details being given of the mileage expected to be obtained from a great variety of repairs, also the cost of various classes of repairs. In order to obtain the maximum efficiency in locomotive repairs he classifies them as follows:

- No. 1. Rebuilt.
- No. 2. New fire-box and general repairs to machinery.
- No. 2A. New fire-box sheet or sheets, and general repairs to machinery.
- No. 3. General repairs to machinery to cost \$500 or over.
- No. 4. Repairs to machinery to cost \$100 to \$500.
- No. 5. Light repairs, labor to cost \$50. To obtain the necessary information

about locomotive condition, the Lackawanna mechanical department sends out circular letters about the first of each month to the general foreman, general boiler foreman, boiler inspectors, division round house foremen, road foremen of engines, traveling fireman, and chief clerk. Each man must come prepared with detailed information on each locomotive in general and its appurtenances in particular. From the engine condition reports, the headquarters force know just what classification to give repairs required.

#### RELATION OF FOREMEN TO THE MEN.

A report on this subject was prepared by T. E. Freeman, Duluth & Iron Range, and it is admirable in every respect. The question is exhaustively discussed, Should a foreman be a leader or a driver?

The first paragraph of the report makes excellent reading and sound advice. It reads: Foreman should be the one to step forward from the crowd and show the way out of a difficult emergency, to be a leader. Leadership is one of the world's most precious possessions. For the common good, leadership should be cherished, encouraged and allowed to reap its full reward. This is the lesson which we must take to heart, we must continue to keep wide open for every one, for the man of one talent, and for the man of many talents, the golden gate of opportunity. Equality of opportunity implies the right to equality of results, and with equality of opportunity or anything approaching it, there always will be equality of results and why? Equality of opportunity means that the man of one talent, and the man of many talents should each have a fair opportunity to do the most and the best of which he is capable and secure the fair reward therefrom. Foreman, to encourage this, you should keep your assistant in touch with all your work and correspondence so that in your absence he will be able to answer any questions which pertain to your shop. Every man, no matter what the position he occupies, has a sense of personal pride and honor. The workman of today is not a machine that can be driven. The day of that kind of supervision has passed. Workmen of today are commanding more respect and more freedom of thought than ever before. A foreman should never be domineering, manifesting a spirit and disposition that he knows it all.

There are two very important factors in getting out work: First, the man's ability to do the job. Second, his willingness to do it. Encourage shop kinks and draw out the very best that is in the men. Study the character and disposition of your men. All men should be treated alike. If this principle is carried out, the foreman will have the full confidence of all his men. A foreman's character should be such as to appeal to his men in every

thing that stands for good, pure and upright manhood. If the foreman patronizes the saloon, how can he exercise discipline over the men who do the same.

When you issue orders, see that they are promptly obeyed. If at any time you have cause to correct any of your men for neglect of his work do it privately and never angrily.

#### NEW OFFICERS.

The following officers were elected to serve for the ensuing year: President, L. A. North, Illinois Central, Chicago; first vice-president, W. T. Gale, Chicago & Northwestern, Chicago; second vice-president, J. B. Wright, Hocking Valley, Columbus, O.; third vice-president, George H. Logan, C. & N. W., Clinton, Ia.; fourth vice-president, W. H. Warner, N. Y. Central, Elkhart, Ind.; secretary-treasurer, William Hall, C. & N. W., Winona, Minn.; chairman of executive committee, E. E. Griest, Pa. Lines, Ft. Wayne, Ind.

The by-laws were amended to make the secretary-treasurer permanent instead of elected annually.

#### BUSINESS OF NEXT CONVENTION.

The subjects for investigation and report next convention are: 1. Engine failures. 2. Methods of meeting requirements of Federal Inspection Law. 3. Alinement of locomotive parts. 4. What interest has the locomotive foreman in car matters?

#### Safety on Grade Crossings.

Mr. J. A. McCrea, general manager of the Long Island Railroad, has carried on what has proved to be a most comprehensive, novel and effective campaign for safety at grade crossings, the result being that not a single life has been lost at a Long Island grade crossing during the summer season. What this record means is only apparent when it is recalled that between 1911 and 1914 some 39 persons—an average of nearly ten a year—were killed on Long Island grade crossings because they took chances, because they were reckless, and because they failed to read and obey the railroad's warning to stop, look and listen before crossing the tracks.

Grade crossing accidents form a goodly proportion of the mishaps befalling automobiles. An investigation by a United States railway company showed that on its grade crossing 69.5 per cent. of the motor vehicle drivers looked neither way before crossing the tracks, 2.7 per cent. looked one direction only, and but 27.8 per cent. looked both ways. Reckless driving over the tracks was indulged in by 19.3 per cent. and only 0.2 per cent. stopped their machines before driving across. The example set by the Long Island Railroad is worthy of emulation, and it is gratifying to observe that the railroads generally are doing their best to lessen these mishaps.

# Test of Locomotives

By D. R. McBAIN, Superintendent Motive Power, New York Central Railroad

## Durability of Flexible Staybolts and Belly Braces When Left Slightly Slack—Effect of Prossering—Patching Flue Sheets

As stated in the September issue of RAILWAY AND LOCOMOTIVE ENGINEERING, we had another experimental installation of flexible staybolts on a Pacific type locomotive, a view of which is shown in Fig.

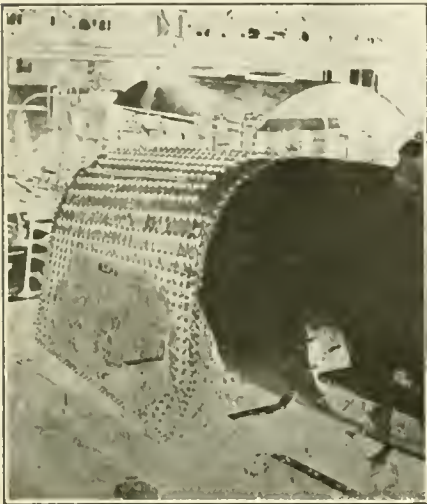

FIG. 16.

16. The particular change of experiment was that we allowed 1-16 in. of slack on the outer rows of staybolts on the back head and sides and 1-32 in. of slack on the adjoining rows of bolts all around. This locomotive is still in service with the firebox that was put in in 1910, with the exception of the addition of a new tube sheet that was necessary on account of the application of the superheater. The engine has run 340,997 miles, and during this period of service there has never been a broken staybolt, and no repairs of

full installation of rigid bolts, in the first four or five months of service we found a great number of broken or fractured bolts in the throat sheet. These engines came in at the end of their trips with half a dozen or more bolts in the throat sheet leaking through the telltale holes, and we instituted investigations to ascertain what the trouble was. We removed all of the bolts in the throat sheet of one of the engines, and found that a large number of the bolts were broken, and many of them partially broken. The remedy that we applied in that case was, that we removed all of the rigid bolts and put in a complete installation of flexible bolts, as previously referred to, over the entire throat sheet, and the remedy was so complete that we had no further trouble in that part of the boiler.

We also had the same experience with breakages in the shell braces, that is, the flue sheet braces from the belly of the boiler. We had several engines come into the shop with all of these braces broken, and the ends of the broken bolts covered with mud, showing that they had been broken for some time.

In placing the belly braces in position we endeavored to allow 1-16 in. slack under the nut and the crow-foot on the belly of the boiler. This is usually done by first pulling one nut up as tight as possible, and then backing it off 1-16 in. and then setting the jam nut snugly up against it. This proved an effectual rem-

practice at the present time, an illustration of which is shown in Fig. 17.

As illustrating these experiments Fig. 18 is a diagram made to show the result

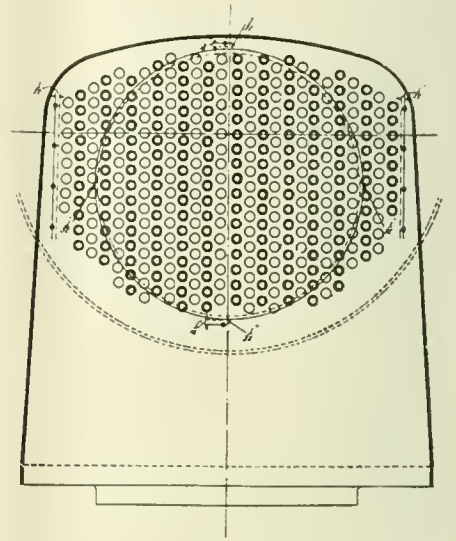

LOCATION OF FLUES.  
LOCO. CLASS N-2.

FIG. 18.

of a recent investigation to determine the direction and extent of expansion in a flue sheet resulting from prossering in a set of flues. The dotted line circle was made before the flues were set and the solid little circle had widened 1-32 in. outside of the dotted bottom line at the

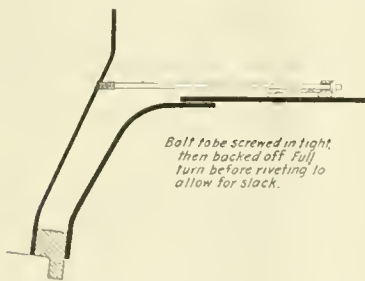

FIG. 17.

any kind have been made in the firebox excepting what may be called the usual mud ring corner patches common to all classes of locomotive fireboxes in hard service. The firebox is still in first class condition, and, according to the latest report, is apparently good for five or six years more of active service.

Special reference might be made in regard to the throat sheet. On a number of the larger locomotives that came with

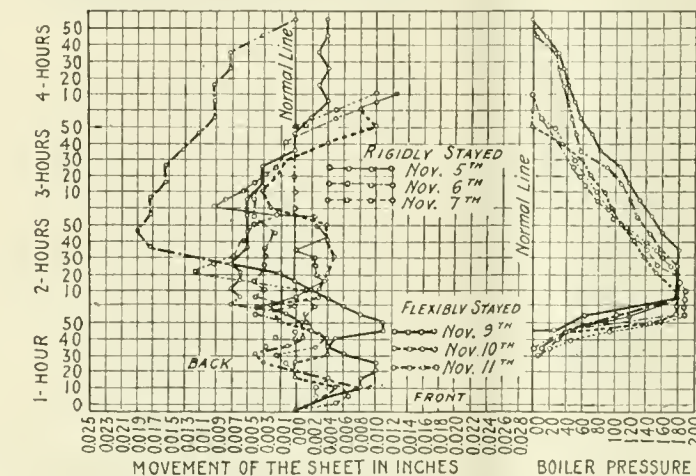

FIG. 20



FIG. 19.

edy in the breaking up of belly braces, and there is very seldom, if ever, one broken bolt now, and never a single instance of a case of pulling the rivets off on the fire side of the flue sheet. This method of attaching the belly braces is our standard

sides and bottom, and 3-32 in. at the top, and, bearing in mind that we, at that time, prossered the tubes at least once every thirty days it will be readily understood why we have the hump at the front end of the crown sheet, as shown

in Fig. 19 on the top. It has also occurred in our experience that the  $\frac{3}{4}$  in. radius for flue sheet flange, as shown at the bottom of Fig. 19 gives better results

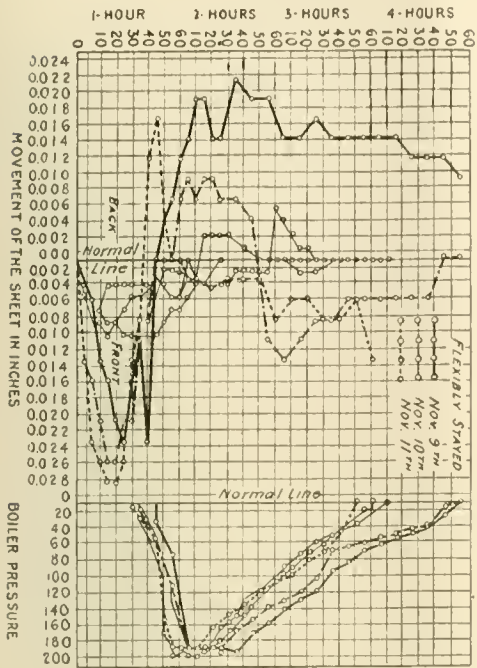

FIG. 21.

than the 2 in. radius, as shown in the center of Fig. 19.

Fig. 20 is a diagram indicating the relative movement of the back tube sheet to the throat sheet, and in raising the steam

boiler. This shows very plainly that there is a necessity for some freedom of the sheets longitudinally in order to avoid excessive strains being set up.

Fig. 21 shows the relative movement of the back firebox sheet and the back boiler head, and Fig. 22 shows the relative movement of the crown sheet to the roof sheet.

Fig. 23 shows a process recommended for patching the top of a flue sheet that has been cracked from the top flue holes up through the flange. The reinforced rib across the back, as shown in this diagram, has proved very satisfactory, so much so that it is evidently as strong as the original sheet before the beginning of the cracks. In this instance we found it to be good practice to eliminate the four small tubes and fill the holes as shown. It may be stated that for the horizontal crack around the flange of the flue sheet, a satisfactory job can be made without patching by simply following the process, as shown in Fig. 23, in the matter of preparing the cracks for welding and making the reinforcement rib along the back on the water side, but we do not put in a patch on account of a horizontal crack along the flange of the back flue sheet. The patching process is resorted to only when the sheet cracks from the top flue holes up and around the flange. We have had no difficulty whatever in holding the horizontal cracks by the in-welding process reinforced just as we

made in appreciation of the value of the experiments, and much new matter was added by several leading railroad men, among which were suggestions looking toward a lessening of the tendency to fracture in the parts more liable to such troubles. Among these several railroads were reported upon as favoring the placing of the flues further away from the top flange of the flue sheet thereby lessening the tendency of the flange cracking at that

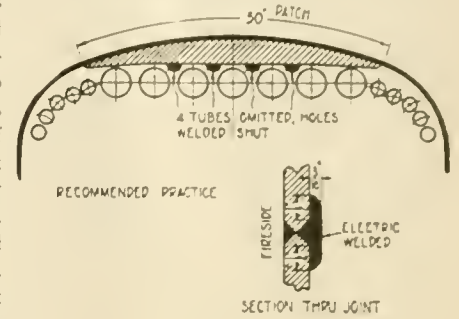

FIG. 23.

point, and also by making the angle of the flange much less than the usual 90 degree angle. Another marked preventive of flange cracking has been the lowering of steam pressure since the general introduction of the superheater appliance. The Pennsylvania Lines West reported the complete absence of broken staybolts where the complete installation of flexible bolts had been accomplished. The kind of coal also was reported as affecting the

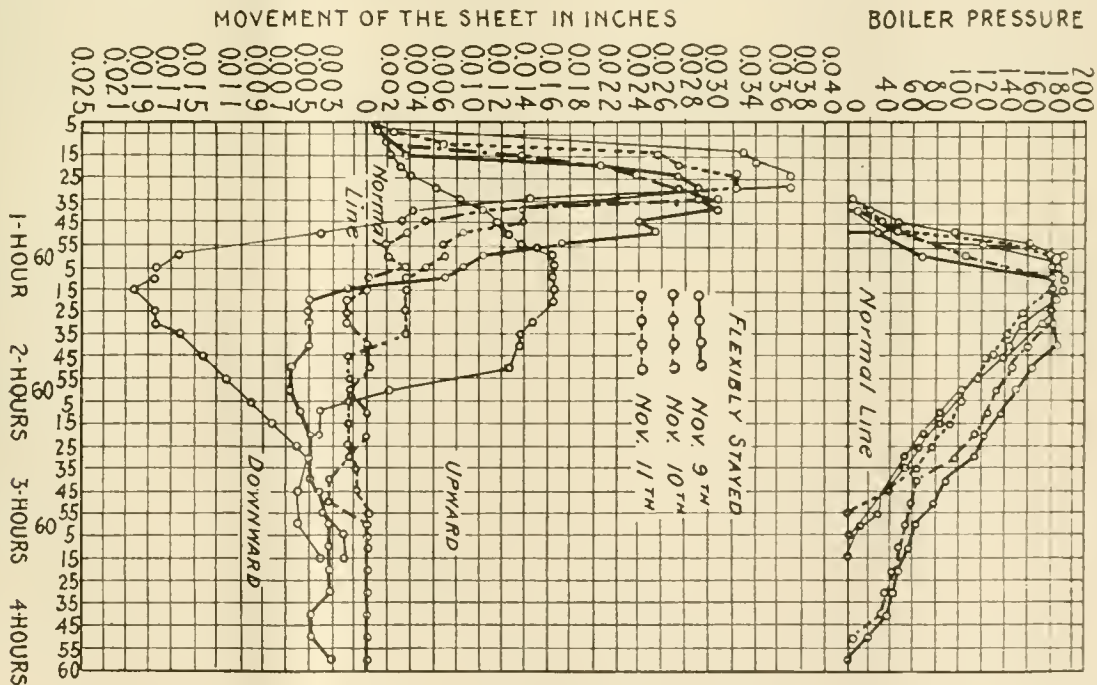

FIG. 22.

pressure from 0 to 200 pounds when the fire is first applied on engines of exactly the same type, one having all flexible staybolts and the other all rigid staybolts, the phantom lines indicating the sheet movement on the rigidly-stayed boiler, and the heavy lines that of the flexibly stayed

reinforce the seam between the patch and the flue sheet proper.

In closing Mr. MacBain's instructive record of tests of locomotive boilers it may be added that many important comments, mostly of a laudatory kind, were

side sheets of the firebox by the absorption at high temperature of sulphur resulting in a greater degree of brittleness. Others reported marked advantage in welding the seams of the firebox and combustion chamber, the only riveting being through the mud ring.

# Relation of Slid Flat Wheels to Uniform Retardation

By W. V. TURNER, Assistant Manager, Westinghouse Air Brake Company

With reference to the necessity for an efficient brake for the heavily loaded freight car, I have pointed out some of the requirements for such a brake on level roads, and before mentioning the necessity for an empty and load brake in grade service, I would mention the slid flat wheel in connection with the lack of uniform retardation between different vehicles in a train of cars.

Of the two figures used in connection with this article, Plate 1 graphically illustrates the relation of the empty and load brake to uniform retardation. The top figure illustrates the ideal condition of two cars, one empty and the other loaded retarding at the same rate, due to the fact that each is braked at 40 per cent. There is no tendency here for slack to run in either direction, in or out. The second figure shows an empty car braking at 60 per cent. and the loaded car at 40 per cent., the loaded car preceding the empty and pulling on it with a force of 1,837 pounds. This is the force acting after the slack has run out, and both of the figures illustrate conditions arising from the use of the empty and load brake; the lower figure illustrates the condition inherent in the standard single capacity brake. The loaded car is braking at 16 per cent. and the empty car at 60 per cent., the difference causing a draw bar strain of 4,040 pounds after the slack has run out. This force in itself is of small moment, but it indicates a difference in retardation which, in causing cumulative slack action, pulls out draw heads, puts lading through the ends of cars and does all the other damage arising from the violent running of slack.

But the relation of the slid flat wheel to uniform retardation, or rather, lack of it, is not so generally apparent. Plate 2 has been prepared to illustrate this. In the first place, it will be necessary to mention the influence of adhesion or wheel-rail friction on the braking problem. Fig. 1 of plate 2 shows a locomotive driver with the crank pin on the top quarter and the force applied by a horizontal cylinder with the main rod of infinite length. As long as the wheel does not slip it is evident that the wheel moves about the point of contact of the wheel with the rail as fulcrum. A line joining the crank pin with this fulcrum point may be considered as a simple lever of the second class. The delivered force appears at the center of the wheel and is the force which moves the train. Strictly the net force serving to move the train is the difference between the delivered and applied forces, because the reaction of the steam acting against the back cylinder head is exactly equal and opposite to the applied force on the piston and is applied through the locomotive

frame to the center of the wheel and directly opposes the delivered force. This difference between the two forces sets up a thrust of the wheel to the left against the rail which thrust is equal, of course, to the force difference causing it. This thrust of the wheel on the rail is exactly equaled and opposed by the thrust of the rail on the wheel. That is, action and reaction are always equal and opposite. With reference to the ground this thrust of the rail on the wheel is the force which, applied from a point external to the locomotive, moves it. If this is only remembered it will be easy to visualize the effect of the rail on the train when the brakes

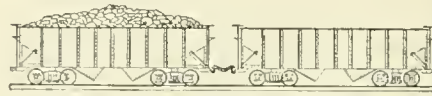

Loaded Car, 150,000 lbs. Empty Car, 40,000 lbs.  
Braking Power Braking Power  
40% on 50 lbs. cyl. pres. 40% on 50 lbs. cyl. pres.  
No Draw Bar Strain Whatever.



Loaded Car, 150,000 lbs. Empty Car, 40,000 lbs.  
Braking Power Braking Power  
40% on 50 lbs. cyl. pres. 60% on 50 lbs. cyl. pres.  
Draw Bar Strain 1,837 Lbs.



Loaded Car, 150,000 lbs. Empty Car, 40,000 lbs.  
Braking Power Braking Power  
60% on 50 lbs. cyl. pres. 60% on 50 lbs. cyl. pres.  
Draw Bar Strain 4,040 Lbs.

PLATE 1.

are applied. Now, if the locomotive be reversed, which means also reversing the forces, as indicated by the dotted lines, a retarding force is set up and finally applied by the rail to the wheel in a direction opposed to the motion of the train, according to the sequence above pointed out.

Plainly, if the fulcrum, or point of purchase, at the contact of the wheel with the rail, should fail, the drivers will slip and the train fail to move, or at least fail to be accelerated except for an amount equal to the kinetic friction, or friction of relative movement, between wheel and rail. The value of this kinetic friction is far less than the static or rolling friction, which is most frequently termed "adhesion." This failure of the fulcrum occurs when the thrust of the wheel on the rail exceeds the adhesion between the wheel and the rail. This adhesion is generally taken as 25 per cent. of the weight resting

on the rail. With a good dry condition of tread and rail surfaces 30 or 35 per cent. may be the limiting value, and, on the other hand, the adhesion may drop to 15 per cent. or less if the surfaces are slippery, due to frost and so forth.

Considering Fig. 2 of plate 2, the crank pin has been shifted 90 degrees and the cylinder placed vertically, something like a walking beam engine for a river boat. With reference to the engine the pin is still on the quarter. Our lever now becomes instead of the straight line lever of Fig. 1, an offset lever, otherwise Figs. 1 and 2 are much the same. Were the crank pin shifted to the tread of the wheel the engine stroke would equal the wheel diameter and the same applied force would be much more effective in moving the train. Our lever would now be a 1 to 1 lever—that is, the power arm and weight arm would be equal, and so, of course, would be the applied and delivered forces.

This is just the condition of affairs in Fig. 3. The applied force is the force of friction of the brake shoe applied at the tread of the wheel, and this is a 1 to 1 offset lever with the fulcrum at the point of contact of wheel with rail. The delivered force at the center of the wheel opposes the motion of the train. It is equal to the applied forces, which, in turn, is equal to the braking ratio (actual) times the weight on the wheel times, the coefficient of brake shoe friction. It is also equal to and agrees in direction with the thrust of the rail on the wheel. As before noted, this is limited in value by the adhesion between the wheel and rail.

If a car in motion and with the brakes applied suffers impact in a direction such that the car is accelerated, the rotative speed of the wheel will be increased also, but to accelerate the wheels a certain thrust is required from or of the rail. This is in addition to the thrust caused by brake shoe friction. If the sum of the two thrusts exceeds the adhesion the wheel will slide. The impact lasts a very short time only, and the rail thrust brought into play by this impact lasts only as long. But the brake shoe friction in this very short interval of time has jumped up in value, becoming static where it was kinetic before, and the wheel-rail friction has dropped in value, becoming kinetic where it was static before and the wheel continues to slide. In other words, the impact has "knocked the car off its feet" and brake shoe friction keeps it "off its feet."

However, even if this occurs and the wheels slide momentarily, it does not always follow that they will continue to slide, for if the pull of the rail with the

wheel sliding exceeds the pull of the shoe to slide that it will always continue to slide, and, also, that a wheel can be slid

or to keep a car off its feet, once it has been knocked therefrom, either the cylinder pressure must be high or the rail bad, or both. The assumption made in the analysis appearing on plate 2 is a cylinder pressure of 34 pounds and a wheel-rail friction dropped from 25 per cent. to 10 per cent. and a rise in shoe-wheel friction from 15 per cent. to 30 per cent. With a loaded car the cylinder pressure will have to be very high and the rail very bad before the wheels can be slid from a standstill or will continue to slid after a shock has broken the static friction between the wheel and the rail—that is, slid flat wheels appear on empty cars much more frequently than on loaded cars. The cylinder pressure or rail condition necessary to keep wheels sliding on passenger cars is much less extreme in value, due to the use of a much higher braking ratio than on freight cars.

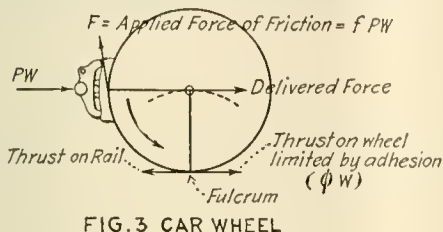
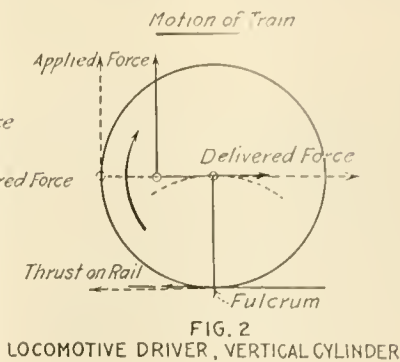
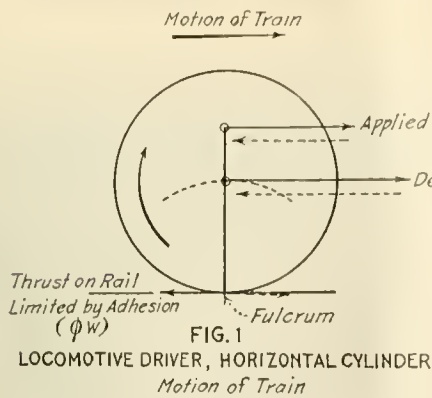

Wheels slide (or slip in the case of drivers) because the fulcrum at the point of rail contact fails. That is, the demand on the rail in the way of the 1st exceeds the adhesion or static friction between wheel and rail.

A buff or jerk in the direction of motion of the train increases the car velocity and the rotative speed of the wheels. A certain thrust on the wheels is required of the rail to increase their angular velocity. If the brakes are applied this thrust is augmented by the thrust due to brake shoe friction. This total must not exceed the adhesion, if the adhesion the car is said to be "knocked off its feet."

And impact opposite to the direction of train motion neutralizes the rail thrust due to braking.

A freight car weighing 50,000 lbs. has an adhesion of 3,125 lbs. per pair of wheels, if the adhesion factor  $\phi$  is 25%. A 15 lb. brake pipe reduction gives 680 lbs. brake shoe friction. For 60% braking ratio on 50 lbs. cylinder pressure, 85% rigging efficiency and 15% brake shoe friction. An impact of 200,000 lbs. will bring the total rail thrust up to the above adhesion limitation. If the braking force is greater, the impact greater (not unusual in service), or the adhesion less, the car will be "knocked off its feet." If the brake shoe friction at this instant exceeds the wheel-rail friction the car will be held "off its feet." This will be true here if the rail friction drops to 10% (1,250 lbs.) and the shoe friction rises to 30% (1,380 lbs.), due to the change from static to kinetic friction and vice versa, respectively. Under the same conditions an impact in the opposite direction must exceed 300,000 lbs. to knock the car off its feet. The impact computation is based upon two 700 lb. wheels and a 500 lb. axle having a movement of inertia of 143.

PLATE 2.

and so continue. This statement will help to nail the fallacy that once a wheel starts from a standstill with a low cylinder pressure. To slide the wheel from a standstill,

An impact opposed in direction to the motion of the train can effect the same result if it be enough greater, other things being equal, to neutralize the rail thrust set up by brake shoe friction and carry in the opposite direction beyond the limit of wheel adhesion. The wheel once stopped in rotation, be it but for an instant, is readily "locked" by the brake shoe, as above pointed out, and it continues to slide, provided the brake shoe friction exceeds the wheel-rail friction.

Thus, it is obvious how prolific in slid flat wheels shocks may be due to lack of uniformity in braking, and thus the role of the empty and load brake in eliminating slid flat wheels and all other evils arising from slack action is most apparent.

## Repairs on No. 6 Distributing Valve

By J. H. HAHN, Carolina, Clinchfield & Ohio Railway, Erwin, Tenn.

Considerable comment has been made in regard to a peculiar defect of the No. 6 distributing valve. It is not, properly speaking, a mechanical defect in the design or construction of the valve, but it is a peculiarity of this particular valve making a chattering or fluttering sound which is produced by the reaction of the air upon the face of the exhaust valve which has the effect of damaging the application portion of the valve. The trouble is usually experienced on railroads operating in mountainous districts, and in locomotives in heavy switching service, where it frequently becomes necessary to use the independent brake valve in quick service position. The vibrations at times seemed sufficiently strong to shake the valve off the bracket, and has the effect of shaking the entire cab of a Mallet type locomotive.

Upon examining a number of valves which were found with broken exhaust valves, we found that the guides or lugs on the small end of the application piston were worn so badly that the entire weight of this part of the piston rested upon the

exhaust valve. This defect, together with the sudden rush of air when the independent brake valve was placed in quick service position would cause the exhaust valve to vibrate upon the seat. The

ening them and do not remedy the defect.

In a section where the air brake is put to a most severe test and where formerly a good deal of trouble was experienced with broken exhaust valves we have suc-

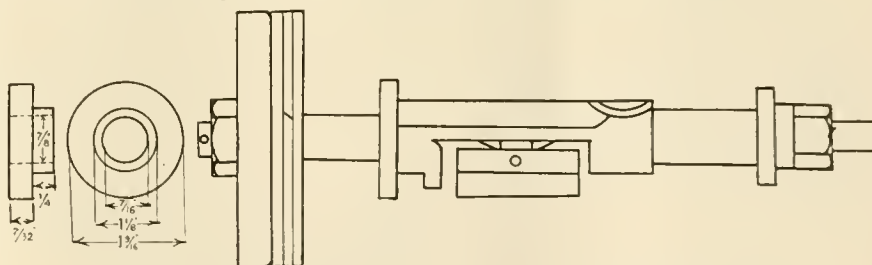

BRASS COLLAR. METHOD OF APPLYING COLLAR TO PISTON.

trouble can be overcome by several methods. The application of a new piston was not advisable unless the bush was also renewed and this is rather expensive. Temporary repairs can be made by putting a stronger spring under the exhaust valve or strengthening the wings of the exhaust valve. However, these methods simply prolong the life of the parts by strength-

ceeded in entirely overcoming the trouble by applying the brass collar shown in the sketch. This is done by turning off the lugs or guides on the piston, and turning piston to a diameter of  $\frac{7}{8}$  in. back 31-32 in. from the end. The collar is clamped by nut No. 21. When worn, new collars can be applied in like manner with little delay.

# Facing Jig for Throttle Yoke of Monitor Injector

By F. W. BENTLEY, Jr., Missouri Valley, Iowa

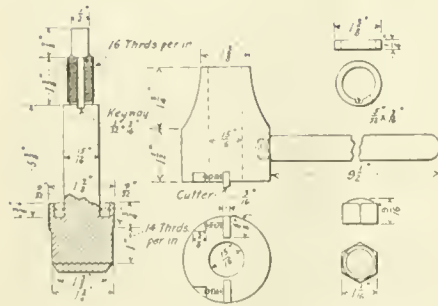

DETAILS OF FACING JIG FOR THROTTLE YOKE OF MONITOR INJECTOR.

The sketches and photograph show construction and details of a very handy jig for facing the throttle yoke joint or seats of Monitor injectors. The guide, spindle, and connected parts hold the cutters squarely over the joint face. These joints are frequently found badly dented as well as irregular, necessitating the use of a quick cutting rigid tool. A spring of any nature suitable in size is inserted in the recessed or cupped portion of the guide.

The writer has used reamers of several designs constructed for this purpose, but the above will be found most practical in every respect, as the cutters are few, being quickly renewed, sharpened and lined.

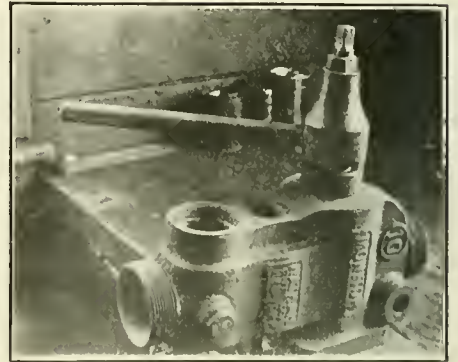

FACING JIG IN POSITION.

## Three Way Cock for Operating Air Presses.

By E. L. BOWEN, AIR BRAKE FOREMAN, ILLINOIS CENTRAL RAILROAD.

Among other mechanical appliances necessary for our work here some three way cocks for operating small air presses had to be made, and the accompanying

engine named "William Merritt," is very interesting, but perhaps the writer is not aware that the Boston & Maine road gave orders for four other freight engines to the eminent locomotive constructor, William Mason in 1872. These were named and numbered as follows: No. 62, "Cumberland," delivered July 5, 1872; No. 63,

the exhibit. Safety appliances have recently been added. The exhibit has attracted much attention in international and industrial expositions in various sections of the country, and is growing in importance and interest.

### Extending the Armstrong Plant.

The constantly growing demand for Armstrong tool holders is reflected in the fact that the Armstrong Bros. Tool Company, Chicago, is building a 50 x 70 ft. steel and brick addition to their drop forging department. They are also erecting a reinforced concrete fireproof building 60 x 130 ft., four floors, to be used for finished stock warehouse, shipping department and offices. These buildings with new machinery and equipment to be installed will largely increase the company's facilities for taking care of its rapidly increasing business.

### Oldest Locomotive Still Working.

One of George Stephenson's first engines is still in operation at Hetton Colliery in England, where it was first put into use and where it has been in constant service since 1822, the year in which it was built. Although the English government has offered to purchase it for preservation in one of the museums, the owners say they will keep it.

### To Clean Rusty Steel.

Mix ten parts of tin putty, eight parts of prepared buck's horn, and twenty-five parts of spirits of wine to a paste. Cleanse the steel with this preparation, and finally rub off with soft blotting paper.

### Zinc.

Of all common metals zinc expands and contracts the most for any increase or decrease of temperature; hence it is sometimes particularly valuable where expansion and contraction with variations of temperature are desirable.

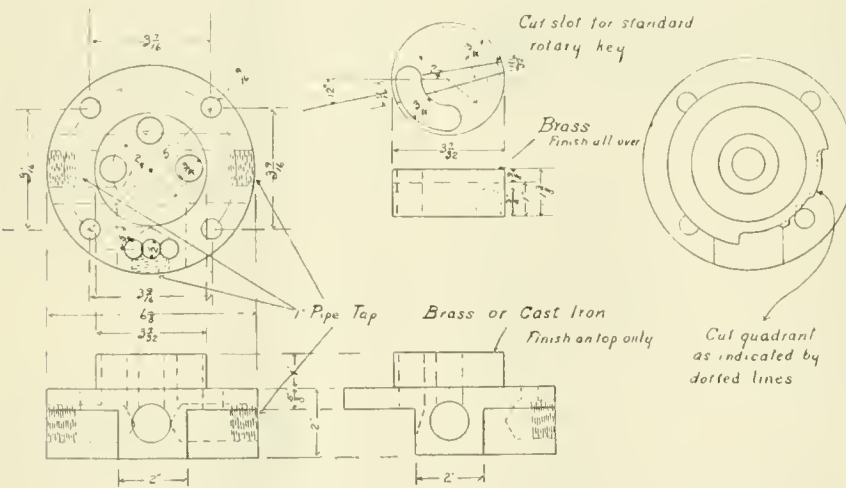

DETAILS OF THREE WAY COCK FOR OPERATING AIR PASSES.

drawing may be of interest to some of the readers of RAILWAY AND LOCOMOTIVE ENGINEERING as showing the details of the construction that we followed. We used a standard upper case rotary key and handle for a G 6, brake valve in connection with the brace valve and seat shown in the drawing. As will be readily noted, the parts are simple, the machine work is comparatively easy of accomplishment, and the valve could not be surpassed in the quality of efficiency. They have been thoroughly tested in service at the McComb City shops, and met all requirements.

## Mason Engines on the Boston & Maine

By HERBERT FISHER, TAUNTON, MASS.

The illustrated article in the September issue of RAILWAY AND LOCOMOTIVE ENGINEERING relating to the Boston & Maine

"Transport," delivered July 27, 1872; No. 64, "William Merritt," delivered August 6, 1872, and No. 65, "Samoset," delivered August 21, 1872. Mr. Merritt, not desiring to have his name placed on a freight engine, the name on the No. 64 was changed to "Pilot." These engines all performed excellent service. Compared to present day engines their yoke was easy and their burden was light.

### Historical Exhibit.

The exhibit of old locomotives and cars used on the Baltimore and Ohio was transferred from Pittsburgh to Detroit during the Safety Congress held there last month. Examples of the methods of transportation used from the early ages of civilization to the inception of rail transmission and the invention of the locomotive forms part of

## Improved Quick Action High Power Hand Brake

An improved quick action, high power hand brake has been designed and perfected in the engineering department of the Bettendorf Company, Bettendorf, Iowa, and repeated tests have shown that it gives a quicker hand brake application than was obtained with the devices commonly in use, and also of given effort employed by the operator delivers a high force at the cylinder push rod or other connection, without wasting the operator's effort, as is the case when the present day hand brake chain winds upon itself on the ordinary staff.

As shown in the accompanying drawings, the device consists of two power arms attached to an operating lever, the longer arm of which connects to a rack through the medium of a spring, while the shorter arm is capable of operating the same rack through the medium of a pawl. For a given movement of the operating lever, the end of the long arm with the spring connection travels faster

or considerable shoe clearance, as with a short piston travel.

It has also been demonstrated that the breaking or permanent setting of the spring will not destroy the effectiveness of the brake, but merely increases the number of strokes necessary to obtain a full application. In the matter of safety also the device can be easily operated with one hand, while the other hand can hold to a grab iron for protection.

### Safety Car Loaned to Industrial Commission.

The Baltimore & Ohio has arranged to loan to the Industrial Commission of Ohio a vestibule passenger car which is fitted up with safety devices, pictures and other material dealing with educational accident prevention, and which will be operated through the State of Ohio. A new feature is the placing of transpar-

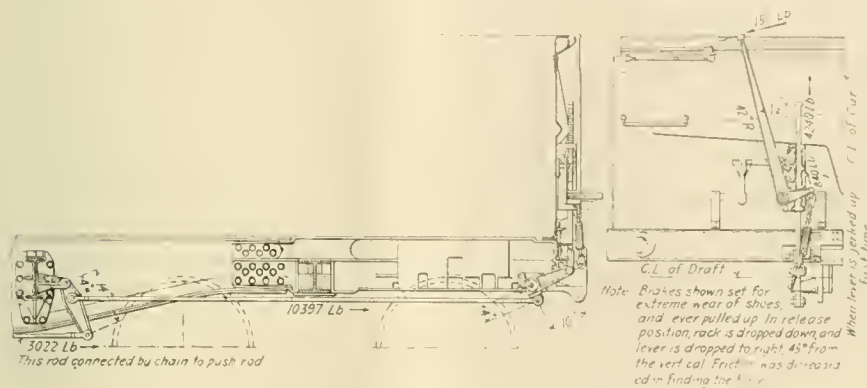

DETAILS OF IMPROVED HIGH POWER HAND BRAKE.

than the short arm, and this travel determines the rate of rack movement until the resistance of the rack becomes sufficient to cause the spring to elongate. When the elongation of the spring permits a travel of the rack slower than the travel of the short arm, the pawl then engages the rack and thus an automatic change from a quick action low power to a slow action high power is brought about. If the piston travel is so long that one movement of the hand brake lever will not give a full brake application, then the first movement is utilized in taking up slack only. The second or successive movements then produce the power, the pawl only acting during the second or third hand brake movement.

By this means some of the objections to most quick take-up schemes have been overcome, for the reason that nearly all of these devices are very weak in brake force if the shoe clearance is small. With the new device as strong an application can be obtained with a long distance travel

encies in the windows of the car showing various ways by which accidents occur and can be prevented, the method having been decided upon so as not to encroach upon the space that will be required for the exhibits to be placed in the car by the various corporations who will participate.

### Canadian Railway Commission.

There is an impression that the commission appointed by the Canadian Government to investigate Canadian railways will lead to government ownership of all lines. It will be many years, however, before that point is reached, if predicated upon what has been done in the United States as the undertaking will take some years to complete, the same as has the valuation of railroads in the United States, and a corresponding increase in expense far beyond what was contemplated by those responsible for initiating the work.

### New Process of Preserving Timber.

What is known as the "Nodon" process for drying and conserving timber is meeting with much success in Europe. The method makes use of electricity. A strong electric current passes through freshly-cut wood and appears to cause a chemical change resulting in oxidation of certain parts, together with a physical change in the cellulose. On account of this, the wood is better preserved against the action of fungi and is more suitable for mechanical use. It is said that in a few hours a thorough oxidation of the wood sap takes place by this process, which ordinarily requires several months in free air. The method can be so successfully applied to green timber that it is thoroughly seasoned in a few weeks. The moisture in the wood helps to carry the electric current and hence, when the process is applied, the timber should not be too dry—in fact, immediately after cutting is advisable. The electrical energy required is 3 to 6 kw. per cubic yard.

### "Dog Ear" Spikes.

American manufacturers and engineers have had brought to their attention by an order placed in this country the "dog ear" feature of the standard spikes used on Russian railroads. It is understood that an Eastern railroad will experiment with them to determine whether they are superior to the style of spike that is standard in this country. It is claimed that they afford better protection from salt water drippings from refrigerator cars, and a better grip for claw bars when driven down upon the plates.

### Great Northern Pension System.

The Great Northern is establishing a pension system for employes of the road. It is intended as a memorial to James J. Hill, who had formulated plans for the pension fund before he died. It will provide for employes who have been in the company's service for 20 years or more, and fixes the age of 70 for compulsory and 65 for voluntary retirement. Each pensioner will receive 1 per cent. of his average monthly pay for the 10 years next preceding retirement for each year of service.

### Busy at Baldwin's.

Between 19,000 and 20,000 employes are occupied at the Baldwin Locomotive Works, not including those employed in the affiliated companies at Eddystone. The company has sufficient orders for locomotives and repair work in hand to keep the plant busy for many months to come. About 40 per cent of the locomotive business is represented by foreign orders.

# Railway Engineering

A Practical Journal of Motive Power, Rolling Stock and Appliances.

Published Monthly by

**ANGUS SINCLAIR CO.**

114 Liberty St., New York.

Telephone, 746 Rector.

Cable Address, "Locong," N. Y.  
Glasgow, "Locoauto."

**Business Department:**

ANGUS SINCLAIR, D. E., Pres. and Treas.  
JAMES KENNEDY, Vice-Prest.  
HARRY A. KENNEY, Secy. and Gen. Mgr.

**Editorial Department:**

ANGUS SINCLAIR, D. E., Editor.  
JAMES KENNEDY, Managing Editor.  
GEORGE S. HODGINS, Associate Editor.  
GEO. W. KIEHM, Associate Editor.

**London Representative:**

THE LOCOMOTIVE PUBLISHING CO., Ltd.,  
8 Amen Corner, Paternoster Row, London, E. C.

**Glasgow Representative:**

A. F. SINCLAIR, 15 Manor Road, Bellahouston,  
Glasgow.

**SUBSCRIPTION PRICE**

\$2.00 per year, \$1.00 for six months, postage paid in the United States, Canada and Mexico. For other parts of the world, \$2.50, or ten shillings. Single copies, 20 cents. Remit by Express Money Order, Draft, Post Office Order or Registered Letter.

Mailing address can be changed as often as necessary—always give old and new address, and if you subscribe in a club, state the name of the agent.

Please give prompt notice when your paper fails to reach you regularly.

Entered at the Post Office, New York, as Second-class Mail Matter.

**Announcement.**

We are pleased to announce that Mr. George S. Hodgins, who for about ten years was an editor of this paper, has returned to our staff after an absence of five years. We commend Mr. Hodgins to a favorable reception from his numerous old friends.

**The Fall of the Quebec Bridge.**

The loss of the center span of the bridge at Quebec over the St. Lawrence river, which cast a gloom over the "Ancient Capital" and, indeed, over the whole Dominion, happened early in September. The building of the bridge was a Canadian government undertaking. The piers were 1,800 ft. apart and the center or connecting span was 640 ft. long. In 1907 the bridge gave way and fell in a tangled heap of steel across and into the waterway. The loss of life then occasioned amounted to 90 persons. The bridge as now constructed was completed all but the center span, and it had been brought into position for hoisting and was partly under way when from all accounts one corner slipped from the lifting girder or a sustaining casting broke and the bridge span rolled over into the water.

Elsewhere in this issue we give a snapshot illustration taken at the fateful moment. It may seem strange to some that the barges which had floated the span into position had been withdrawn from beneath the structure and some people thought that they might have been

kept in position and the bridge span blocked up constantly as the hydraulic jacks lifted the 5,000-ton mass. This, however, could not be done, as the total lift was 150 feet, so that when the slip occurred, whether it be due to incomplete or careless fastening, or to the failure of the temporary holding apparatus, there was nothing below the bridge to hold the span from falling into the river. To the lay mind, or in the minds of those who were not present, the absence of continuous blocking below the span meant a chancetaker's risk, which usually spells negligence in some quarter. To those acquainted with this kind of work, the blocking up for 150 ft. of vertical lift on an insecure and floating base, was out of the question. A carefully conducted government inquiry can now alone settle the question of responsibility.

This bridge is the greatest example of the application of the cantilever principle ever applied to any bridge. In the Firth of Forth bridge the piers are 1,710 ft. apart, and this distance is exceeded in the Quebec bridge by 90 ft. The center span of the Forth bridge is 350 ft., while the lost central span of the Canadian bridge was 640 ft. long. The distance from shore to shore of the Quebec bridge is 3,239 ft. The fourth bridge is 5,349 ft. between approaches. The loss of the center span halts the work on the great Canadian bridge at a most inopportune time, and great as is the loss both from a financial and an engineering standpoint, yet if any single doubtful fact concerning this structure or its method of erection, or its handling and placing, shall be learned which will in any way advance engineering science, the price though extremely high in lives, money and reputations, may at least not have been paid in vain.

**The Proposed Eight Hour Law.**

The clamor against the means that have been taken to avoid a great national calamity in the shape of a general railroad strike should neither be disregarded nor taken too seriously. The proposal is an experiment which will be tried some months hence and reported upon. While the action of the associated brotherhoods is the boldest and, perhaps, the most successful stroke ever accomplished by organized labor, it does not rival in magnitude the step in the same direction taken by the united building trades years ago. They whose memories run back to that period can recall the difficulties that had to be overcome, but it will also be remembered that the commercial disturbance immediately rectified itself. The cost of new buildings advanced, and the contractors adjusted their estimates to suit the changed conditions, and the idea of going back to longer hours has never been considered.

The railroad companies, however, are

differently situated. They cannot raise the rates without permission from outside sources, and herein lies the gross injustice under which they have a right to complain. If the change to eight hours should be approved of the raise of rates should be coincident, and not follow after the bankruptcy that would inevitably overtake many of the railroad companies. Anything short of this would be criminal neglect. The Federal commission should not only be empowered but should be compelled to take up the whole subject, as the shortening of the hours of labor is nothing more or less than an increase in expenses, and the questions involved are so interwoven that they cannot be fairly dealt with by separate commissions. This will no doubt be properly placed before the legislature and it is to be hoped that a sense of justice will be awakened to the rights of all concerned.

**Power Reverse Gear on Yard Engines.**

Some people think there is not much to a yard engine except to saw up and down the track all day and that any kind of a yard engine will do. Of course this is a great mistake, but the use of power reverse gear on a yard engine proves it beyond question. It practically facilitates work.

In the first place, power reverse gear makes it easier for the engineman. That means more efficient service by him, because it removes from his work, heavy, unremitting physical toil and clears his mind from the mental revolt always present, due to the dumb acceptance of arduous conditions, that he cannot change, and which make a straight challenge on bodily endurance. This is the psychological factor in the case, which it is unwise to ignore.

The use of power reverse gear enables a man to keep his head out of the cab window all the time. He continuously sees what he is doing. The switchmen on the ground feel safer in their work because the engineman can see what he is doing. The engineman looking at his work all the time and reversing the engine by a simple wrist movement, instead of by a complete body action each time, together with a momentary withdrawal of eye and thought from the work, eliminates several unnecessary movements which would delight an efficiency engineer. Less time is used to reverse, less strength is expended, greater safety is assured, and prompt action follows as a matter of course.

Many yard enginemen are not by any means old, but have reached the point where fatigue troubles them. Many have slight physical defects, such as eye sight below par, a lame foot, or a touch of rheumatism. These men begin work fresh in the morning, but as the day wears on, with work as hard as ever all day, they involuntarily slow down a little,



and the volume of work to be done suffers. Power reverse gear is as fresh in the evening as it was at sunrise.

This brings us to the point, that viewed from an operating standpoint, shows that the engine works evenly and up to full power all the time. When necessity arises it can be pushed with safety. The constant, steady work at full capacity has been found in some cases to decrease the number of engines used. This brings about several most important economies. Not only is first cost, maintenance, and charges wiped off the books, but the space charges wiped off the books, but the space which the discarded engine formerly occupied, and which it required to work in, can be filled with revenue-producing cars, and in this way the capacity of the yard may be increased without the company buying a foot of space. In city limits, growing business may call for increased facilities at a point where no one will sell adjacent property. It may seem strange that a reduction of "working machinery" amounts to more power, greater efficiency, or increased space, but such is the undoubted fact.

#### Boiler Inspection.

It is almost impossible to make the ordinary boiler user realize that a boiler which has been worked for years with safety, is rapidly or gradually approaching a condition when it will be dangerous to be near it. When an ordinary user first gets a boiler into his premises, he is nervous every time he hears the steam blow off thinking the noise indicates a coming explosion, but as usual, familiarity breeds the contempt which ignorance is ever ready to embrace. Most of our States are painfully in want of laws to regulate the control and inspection of stationary steam boilers; and public opinion is slow in making the demand that leads to the necessary law making, although the examples of killed and wounded from boiler explosions are sufficiently numerous to stir people with feelings of humanity to demand a remedy.

Laws requiring a thorough investigation of all boiler explosions by expert inspectors, and the publication of the facts, would do a great deal to prepare the way for effectual remedies. It is not necessary that boiler inspectors should be men brought from outside the works when a boiler is stationed or cleaned. A boiler maker employed by a firm on other work may acceptably act as inspector when a boiler has to be examined. The Railroad Commissioners of Massachusetts, recommended many years ago the enactment of a law requiring all locomotive boilers to be periodically inspected and tested. Most of the railroads considered the law a hardship at first, but most of them came within a few years, to recognize the law as a blessing in disguise. The boilers came to be inspected regu-

larly at trifling expense, and defects of a dangerous character were frequently discovered. The mechanical head of one of the principal railroads in New England made a public statement, after the inspection law had been in force for some time, that he would rather quit the position, than to return to the loose practices that prevailed, before rigid and systematic inspection became imperative. This Massachusetts' law was really embodied in the present regulations of the Interstate Commerce Commission in regard to locomotive boiler inspection, and which has no doubt proved more effective for safety than any such law ever put in operation. Some similar national regulations are imperatively needed for stationary boiler inspection.

#### Broken Rails.

An important announcement was made by the New York Central last month that its staff of scientists, under Dr. P. H. Dudley, C. E., has discovered the cause and a complete remedy for the flaws in steel rails. The matter has been under investigation for many years, and the conclusion is that the interior fissures in many rails are caused by imperfect processes in manufacture, instead of excessive wheel loads as has been generally supposed. Many wrecks have been caused by these internal flaws. In the last fourteen years a total of 3,345 railroad accidents occurred from this cause whereby 206 persons were killed and 7,341 injured with a property loss of nearly \$4,000,000 in the United States. This class of accidents has been found to be preventable, if Dr. Dudley's discoveries can be taken as absolutely correct. The remedies involve the establishment of what will be known as bloom reheating plants to all of the existing rail rolling mills. The importance of the report may be estimated from the fact that meetings of steel manufacturers are now in progress in Pittsburgh, Baltimore and New York to consider the adoption of the new methods in rail manufacture. Favorable action on the part of the manufacturers may be assuredly expected as the independent investigations and experiments with the manufacture of rails for the New York Central, under Dr. Dudley's personal direction, has reduced the breakage of rails from a previous proportion of one in 600 to one in 142,000, which latter rate could now be eliminated making accidents from track failure a thing of the past.

Dr. Dudley's researches have resulted in other important discoveries. He is the inventor of the dynamometer track inspection car, which automatically records in printed diagrams all undulations in rail surfaces, and marks all high or low spots. By the use of this device the aggregate unevenness of the New York Central main line was reduced from eight feet per mile to two feet per mile, and en-

tirely eliminated all low joints. The result of the report of the subject of broken rails, however, bids fair to be the most far reaching of his investigations and has occupied more or less of his time for thirty-eight years, during which period he has been consulting engineer of the New York Central.

#### The Metric System.

There has lately arisen considerable agitation in favor of adopting the French metric system of weights and measures for general use in the United States. The advocates of this movement are mostly schoolmen who insist that the metric system is much more philosophical than that now in use. We do not care how philosophical a system of weights and measures may be so long as the details are convenient and easily understood. We prefer utility to philosophy. From the experience we have had with the working of the metric system in different countries, we don't believe it possesses any merits that commend it for displacing the British system that all English speaking people use.

It is now over sixty years since the firm of William Sellers & Co., Philadelphia, adopted the metric system in an important system in their works, and it has been continued till now and the workmen are as familiar with it as with the inch. After the metric system had been in use in the Sellers' works for thirty years, Coleman Sellers, a member of the Company and one of the most accomplished mechanical engineers of the world wrote: "With this long practice during my connection with the firm, I have written and spoken against the enforced adoption of the system, not only because of the expense involved in changing, but because it is not a practical system; it permits of no elastic graduations of shop or trade sizes. The millimeter is taken as the standard to avoid complication of the constant use of decimals, as nearly all measurements in machine work are less than one meter. The small measure involves many figures, and does not permit any good memorable series. The inch cut up into the natural division by constantly halving permits the use of sizes best suited to the needs of the workmen."

#### Purchasing Railway Supplies.

In the revival of increasing railroad activity and the need of new equipment especially necessary from the fact that during what may be called the lean years much of railroad motive power and other mechanical appliances had been in service, in many cases, longer than they should have been. Not that the neglect was wilful, but traffic had to be maintained with such means as were available, and necessity knows no law. Now that better times are with

us and extensive additions of equipment are in progress it is well to pause for a moment and consider the question of how these purchases are made. One would naturally suppose that those who are most familiar with the requirements of the service expected would be consulted. This is not generally the case, however. It may be taken for granted that in the accounting department the cashiers and chief clerks have their choice of the material and forms necessary, but it does not follow that the men in the mechanical department who are qualified by experience control the choice of the equipment essential to their part of the work. On the contrary, they are generally glad to take what they can get.

Not only so, but very frequently the material supplied could be much improved upon. In the machine shops it would, we suppose, be an infraction of dignity to consult a working machinist as to the best kind of tool adapted to special requirements. He is supposed to do what he is told and keep quiet. The foreman knows his place and remains silent. The master mechanic may do some hard thinking, but there is usually a general above him, and even the superintendents of motive power soon learn that there are other influences at work in the purchase of supplies than the judgment acquired in his experience.

It is not uncommon to hear the heads of mechanical departments complain even of the type of locomotives selected for special work, but they also must needs conceal their thoughts, or, if they speak at all, it must be with a diffident compliance to other powers. The question naturally arises, From what source does this division of opinion and power of purchase come? It is natural to suspect the purchasing agent, but even he should have the benefit of the doubt. He cannot please everybody. He is usually a gentleman of wide experience and may safely be trusted, but he is liable to be controlled by agencies that are past finding out.

#### Improved Railroad Income and Its Uses.

From the official report published last month the comparative gains of railroads for the first six months of 1916 as compared with the same period in 1915 it appears that it amounts to \$166,151,387, or 42.26 per cent. The gross advance is much greater but the expenses are also largely increased. While this large percentage of increase year by year can hardly be expected to continue, it seems assured that an era of prosperity is before us, and that the opportunity to add to the efficiency in raising the railroads to a high level of safety may be accom-

plished and maintained. Much has been said and written on the deterioration of railroad stock, on roadbeds that needed improvement, on terminal facilities that needed enlargement, and it is to be hoped that the railroad companies are seeing their way to appropriate from the present earnings a sufficient amount to carry out the constructive plans to meet the growing traffic conditions.

On the part of the railroad men on whom the increased burden of the work falls, and apart from the bitter controversies arising from the demands of those engaged in some of the departments, it must be admitted that there are large numbers of patient, earnest men who uncomplainingly work from year to year under conditions and with remuneration that might be improved. It is not our province or desire to dwell on particular interests or classes, but it must be admitted that the remuneration to many of the most skilled in the mechanical department has not kept pace with the requirements of the service or the increased cost of living. This is true in the case of many of the master mechanics, and particularly so in that large class of foremen upon whom so much of the growing details of construction and repair work depend, with constantly increasing responsibility. These men are at call at all hours, and may be said to be between the upper and nether millstone, and have not only to bear the brunt of the complaints of the higher officials but have to furnish brains, as it were, to the less skilled who are dependent upon them.

The recent convention of the International General Railway Foremen's Association at Chicago, a report of which appears elsewhere in our pages, serves to give some indication of the calibre of these men, and while it would be unjust to say that their work is not appreciated, we are of opinion that some portion of the improved fortune that is coming to the railroads might be diverted in their direction.

#### Test of Locomotives.

The series of articles on the tests of locomotives looking towards improvement in boiler construction and repair contributed by Mr. D. R. MacBain, superintendent of motive power of the New York Central at Cleveland, as we have stated elsewhere, is not only of vital importance in the realm of scientific investigation, but is also an admirable illustration of what an earnest seeker after facts can accomplish. Perhaps there is no class of railroad men whose time and abilities are more constantly occupied than the men at the heads of the mechanical departments of railways, and it must be conceded that they have more than enough to do to keep the wheels moving, with the constant pressure of economy, induced by

legislation and other causes, that is constantly upon them, and yet we find many who find time to project their keen intelligence into the multiplex channels arising out of their varied experience, among which Mr. MacBain is a shining example. Much of their work is unnoticed and unknown, but it is from this class that real progress comes. In their experience in their journey upwards from the humbler positions, from which they must come, they became familiar with every detail of the mechanical appliances used on railways. All of them could suggest many improvements, but the encouragement is not always as conspicuous as it should be, and just as many a flower is born to blush unseen, so many thoughts of pith and moment perish in the bustle of necessary mechanical activity. In this regard the engineering press affords a proper outlet for these valuable thoughts, and it is a matter of pride and satisfaction to us to have the means in our hands to afford a vehicle for the full expression of such ideas as tend towards improvement in the mechanical department of railways and all that relates thereto, and with the co-operation of many of the most thoughtful of these men we are encouraged in the work in which we are engaged. To this end RAILWAY AND LOCOMOTIVE ENGINEERING was established and to this end it will be carried on.

#### Safety First.

In nearly every machine shop that we have visited lately we have noticed conspicuously displayed notices enjoining everyone that "safety first" should be observed and that "efficiency" is the duty of every person drawing pay in that establishment. We also notice that many of the workmen are disgusted with meddling spirit displayed in compelling them to perform duties in the manner that every self-respecting mechanic will execute of his own free will unmoved by the spirit of meddling. The ordinary workman, when left to follow the bent of his own inclination, is ready to give a fair day's work for the prevailing pay and trying to force him to do more merely rouses antagonism.

#### Railway Cars in Australia.

The Minister for Home Affairs decided to import steel cars for the Australian railways, but the cabinet vetoed his decision. It was found that the material could not be obtained in Australia in time to build the cars for the opening of the new lines; it could be procured in the United States, and the cars could be built in Australia. Local firms will be given an opportunity to build the cars if they are prepared to build the cars in a reasonable time, and if not they may turn their attention again to the American manufacturers.

# Air Brake Department

## B-3-A Conductor's Valve—Calculating Train Stops—Parasite Reservoir Governor

### The B-3-A Conductor's Valve.

The Westinghouse Air Brake Co. has developed a new type of conductor's valve for passenger cars, known as the B-3-A, of which illustrations are shown. This valve has been in service on both steam and electric roads for several years and has proved superior to previous types of



B-3-A CONDUCTOR'S VALVE.

valves and, since no question of interchangeability is involved, railroads are generally adopting this type as a standard.

The peculiar features of advantage embodied in the valve are:

1. It can be installed to much better advantage than the C-3 type as it is compact, requiring but little space for installation, and may be located anywhere in any

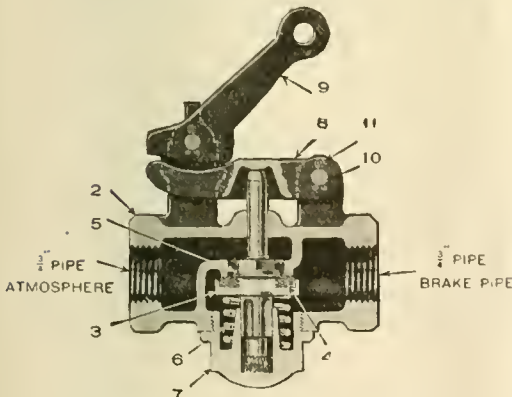

SECTIONAL VIEW OF B-3-A CONDUCTOR'S VALVE.

position. The conductor's valve cord may be arranged to pull from either end of the valve by merely removing the operating lever pin and reversing the position of the lever.

2. It is easier to keep tight than the C-3 and therefore more easily repaired and maintained, thereby reducing maintenance expenses.

3. The rubber seat, which is the part most likely to require renewal, and the brass valve which carries the rubber seat are standard triple valve parts in use on all railroads. The adoption of this valve

does not necessitate carrying additional repair material in railroad storerooms.

4. No hand-fitted parts are used in the valve, so that it can be repaired by any unskilled workman.

5. The operating lever arrangement is such that the valve can be operated very easily, the resistance to movement being such that any reasonable variation from correct alignment of the conductor's valve cord connection cannot affect the reliability of the valve in opening.

Until two or three years ago the most widely used conductor's valve was the type 3-C, of which two forms were developed—one for wooden and the other for steel cars, and while this type has been absolutely reliable and satisfactory, as far as operation is concerned, it possesses the disadvantage of requiring different-sized filling blocks in order to accommodate different-sized partitions. As partitions now vary so greatly in thickness, this has become a source of inconvenience and difficult in installation and this consideration has led to the development of the B-3-A valve.

Like the C-3, it is of the non-self-closing type—that is, when open it will remain open until closed by hand, thus insuring an emergency brake application and the brakes remaining set until the train comes to a stop.

The advantages of the new type of valve are so obvious that unless otherwise instructed the valve will be included in full sets of passenger car brakes without extra charge.

### Calculating Train Stop Distances.

We frequently receive queries concerning the distance in which a train of cars may be stopped with the air brake from different rates of speed, and such questions cannot be satisfactorily answered in the usual manner in the question and answer columns, especially when the writers request formulas that will enable them to calculate these distances. We have always aimed to impress our readers with the fallacy of attempting to calculate a train stop distance that may be made with any nondescript brake apparatus, because the efficiency of a brake must be known before there can be any basis upon which to even estimate the distance required in which to stop a train of cars from a given rate of speed.

In previous issues there has been considerable reference to calculations involving the kinetic energy to be dissipated in stopping a train, and the retarding force available for the work, but such matter was confined to a single car as an exam-

ple and supposedly upon a level track, and as was explained that, assuming the relative energy of the wheels to be offset by journal friction and atmospheric resistance, the work done in stopping a train must be equal to the kinetic energy stored in the train, or the work done is the retarding force multiplied by the distance through which it acts.

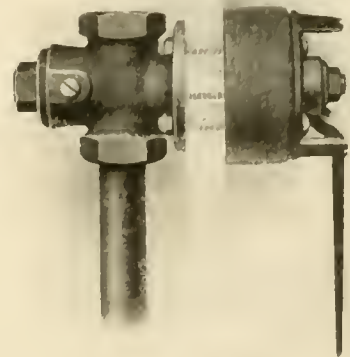

OLD STANDARD C-3 CONDUCTOR'S VALVE.

The retarding force is the weight of the car multiplied by the actual per cent. of retardation obtained with the brake, which is the nominal percentage of braking ratio employed multiplied by the brake rigging efficiency in per cent. and the average coefficient of friction obtained. When the last two factors are found by experiment or test, calculating the distance in which a train should be stopped with the air brake is a very sim-

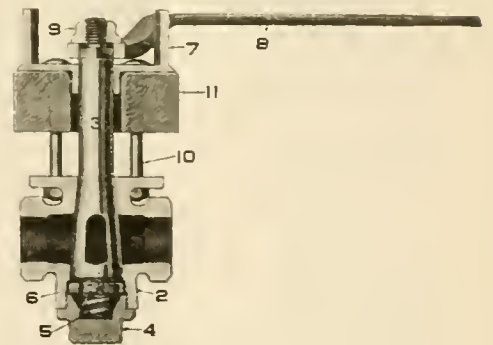

SECTIONAL VIEW OF OLD STANDARD VALVE.

ple proposition, and it can be worked out to within a very few feet of the actual result that will be obtained when stopping the train with the brake. It is not desired to again explain how an average rate of retardation per second may be found or how the per cent. of braking ratio necessary to produce a stop in the required

distance can be found, but we will print a formula used by air brake engineers in calculating the distances in which train stops can be made from various speeds when the efficiency of the brake rigging and the average coefficient of friction of the brake shoes are known, then an effort will be made to explain how the locomotive stop distance is calculated in the results and finally how the estimates are made when the train is to be stopped on a descending grade. If we can succeed in making this clear, it will answer many of the queries propounded by our correspondents.

A formula used for this purpose is  $V^2$

$$S = \frac{V^2}{2g P e f}, \text{ where}$$

- S = The distance of the train stop in feet,
- V = Initial velocity of the train in feet per second,
- g = Acceleration of gravity, or 32.2 feet per second,
- P = Braking ratio of entire train in per cent.,
- e = Brake rigging efficiency, per cent., and
- f = Coefficient of brake shoe friction.

In this calculation V must be in feet per second, or speed in miles per hour multiplied by the decimal 1.47, the latter derived from the number of feet in a mile divided by the number of seconds in an hour, or

$$\frac{5280}{3600} = 1.47.$$

As an example let us assume that V = 60 miles per hour, then V<sup>2</sup> is 60 × 1.47 = 88 × 88 = 7744.

Let P = 150 per cent. or 1.5, an emergency braking ratio that will be developed by the L.N. equipment, or that may be developed by the P.C. or the U. C. equipments, and this for the cars only.

Let e = .85 as an average value of the brake rigging efficiency obtained from tests, and

Let f = .10 or 10 per cent. an average value of the coefficient of brake shoe friction obtained under modern air brake conditions, then

$$S = \frac{7744}{2 \times 32.2 \times 1.5 \times .85 \times .10}$$

Performing the calculation or working out the example will show that the car, or a number of cars, if so braked, will be stopped in 944 feet from the point at which the brakes are fully applied, but the actual stop distances are measured from the point at which the brake application is begun, and as a brake cannot be fully applied in less than 2 seconds unless electric current is used, it follows that the actual distance of the stop will be somewhat longer, and this is usually determined by the assumption that full retarding force is obtained or rather that full

brake cylinder pressure is obtained 2 seconds after the start of the application, or that the average retarding force realized during the 2 seconds is one-half the maximum or in 2 seconds' time brake cylinder pressure rises from zero to maximum, therefore one-half of the full brake cylinder is considered effective for 2 seconds or the full brake cylinder pressure in effect for one second; or, in other words, the train is assumed to be running without any braking effect for one second and the distance traveled during this second is 88 feet, so that 88 feet plus 944 feet equals 1,032 feet, the distance in which the cars in the train will be stopped under the above conditions.

It must be understood, however, that the above figures for brake rigging efficiency and coefficient of friction were obtained from tests made with modern equipment and the best obtainable design of clasp brake gear.

By the expression per cent. of brake rigging efficiency we mean the actual force in pounds that is brought to bear upon the brake shoes as compared with the calculated force; the calculated force is the area of the brake cylinder in square inches multiplied by the pressure per square inch developed in the cylinder and this multiplied by the total leverage ratio employed gives the calculated pressure in pounds that will be delivered to the brake shoes. This, however, does not include certain losses through release springs, deflection of brake gear, friction of the levers and a variety of losses of a minor nature, therefore the actual shoe pressure obtained must be ascertained, and this is the per cent. of brake rigging efficiency.

During tests made with modern passenger equipment cars it has been found that with a well designed brake rigging, a brake rigging efficiency of 85 per cent. can be realized, and that a coefficient of brake shoe friction that will average 10 per cent. can be obtained; the latter will require no explanation if the readers have studied the articles by Mr. Turner that have been appearing in these pages during the past year; however, it has been determined that under present conditions 10 pounds pull of the shoe tending to stop the rotation of the wheel can be obtained as an average throughout a stop for every 100 pounds applied to the brake shoe. Some years ago when passenger cars weighed less than 50,000 pounds and the brake shoe was practically of the same size and composition, a somewhat higher average could be obtained, especially when the speed of the wheel was considerably reduced, but at the present time the brake shoe pressure necessary to produce an efficient brake is so high, and the temperature rises so rapidly, that the coefficient of friction cannot rise above an average of 10 per cent. at any time during a stop made with a modern train from a high rate of speed

Now the foregoing has reference to passenger cars, and a percentage of braking ratio commonly used when operating with modern brake equipments, and each car furnishing its own retarding effect, the train will stop in the same distance as one car, but when the locomotive is attached there are some other matters that must be taken into consideration, and the most important one is that the locomotive is braked lower than passenger cars. The distance required to stop a locomotive from a given rate of speed depends upon the type of brake equipment in use, the braking ratio employed on the tender, the amount of coal and water on the tender, and whether the engine truck wheels are, or are not, provided with a brake, and whether the locomotive has a trailer brake. However, a locomotive in passenger service, under present operating conditions, may be assumed to be equipped with the E. T. brake, where, with a quick-action or emergency application of the brake, brake cylinder pressure will be maintained at at least 75 pounds during the stop and will develop nearly 90 per cent. braking ratio on the driving wheels, and possibly more than this on the tender, and as all modern locomotives are supposed to have engine truck and trailer brakes it is not unreasonable to expect the value of P in the equation to be .9 and the value of e X f to be at least .10, as was derived from the Lake Shore tests at Toledo, Ohio, in 1909, and with these values a calculation of the locomotive stop distance from a 60 mile per hour speed, made with the formula, would show 1,425 feet as stop distance for the locomotive.

During the Pennsylvania-Westinghouse Air Brake Tests at Absecon, N. J., in 1913, a modern 200-ton locomotive, with all wheels braked, was stopped from a 60-mile per hour speed in 1,550 feet, and by using a special by-pass valve, by means of which 140 pounds pressure could be used in the brake cylinders at the beginning of the stop and then blown down as the speed decreased, the locomotive could be stopped in 1,228 feet.

The reference to locomotive stop distances is not made for the purpose of showing how it can be calculated, but rather for illustrating how the locomotive stop distance, when known, affects the stop distance of a train of cars, and assuming that the equations printed have reference to a train of 10 cars, each weighing 100,000 pounds, and the locomotive to weigh 350,000 pounds, let us assume that S = Stop distance of locomotive and train.

- W = Weight of locomotive and cars ..... 1,350,000 lbs.
  - T = Total weight of cars... 1,000,000 "
  - L = Weight of locomotive... 350,000 "
  - C = Stop distance of cars... 1,032 ft.
  - E = Stop distance of locomotive ..... 1,425. "
- then,

$$S = \frac{WCE}{CL + ET} \text{ or, } 1,350,000 \times 1,425 \times 1,032$$

$350,000 \times 1,032 + 1,000,000 \times 1,425$   
or the stop distance for the locomotive and train will be 1,110 feet.

It may also be interesting to note that if but 5 cars were used in the train, and all other conditions were equal, the stop distance would be increased, or would be 1,165 feet, using the same calculations, which will indicate that as the retarding force of the brakes on the train is greater than those of the locomotive, the train brakes will be compelled to assist in stopping the locomotive and ten cars will do this more effectively and consequently in a shorter distance than that required by the five cars, all other conditions being equal.

Assuming now that we wish to know in what distance such a train can be stopped in descending a grade, then the per cent. of grade must first be known, and, as an example, we will suppose it to be 1½ per cent., or a drop of 79 feet to the mile, then it will be necessary to find the braking power necessary to prevent an acceleration of the train on the grade, and this may be found by the use of the following formula,

Where R = The braking power necessary to prevent an acceleration, and  
G = Per cent. of grade,  
e = brake rigging efficiency in per cent, and  
f = Coefficient of brake shoe friction,

$$R = \frac{G}{e f} \text{ or } R = \frac{.015}{.85 \times .10}$$

which will show that  $.015 \div .085 = .176$ , or a braking power of 17.6 per cent. will be required to prevent an acceleration, or to equal the force exerted by the train in an effort to descend from the influence of the grade alone. The formula for the train stop distance would then be changed as follows,

$$S = \frac{V^2}{2gef(P-R)} \text{ or, } S = \frac{2 \times 32.2 \times .85 \times .10 \times 1.32}{7,744}$$

the latter figure being 150 per cent. braking power, less 17.6 per cent. required to prevent the acceleration, and in making the calculation it will be found that instead of the train stopping in 1,032 feet, as on the level track, the distance will be 1,165 feet.

For the locomotive the stop distance will then be 1,685 feet, the value of P having changed from .9 to .72, the difference being due to the braking power required to prevent an acceleration of speed

in descending the grade. The stop distance of the locomotive and 10 cars on the 1½ per cent. grade would be,  
 $1,350,000 \div 1,165 = 1,685$

$$1,000,000 \div 1,685 + 350,000 \div 1,165 \text{ or } 1,265 \text{ feet.}$$

While the above will present the average stop distances with modern brake apparatus, we wish to impress upon our readers that the object is to show the difficulties that are encountered in attempting such calculations and the factors that must be considered and compensated for, rather than to show the distance in which trains may be stopped.

**Parasite Reservoir Governor.**

The use of compressed air on locomotives for pneumatic devices other than the air brake, such as reversing gear, bell-ringers, water scoops, sanders and fire door openers, has reached a stage where it is considered necessary by some roads to protect the supply of compressed air for the brake from becoming depleted from the operation of these "parasites."

To accomplish this protection, the Westinghouse Company has developed a device known as the Parasite Reservoir Governor, which is so designed to permit charging of the parasite reservoir (or reservoir from which the parasites are supplied) from the main reservoir, only when main reservoir pressure is above a certain predetermined amount sufficient to safely operate the brakes. The air operated devices on the locomotive are thereby prevented from "robbing" main reservoir pressure and, in consequence, the brake system itself.

The governor consists of a diaphragm portion, which is identical with the diaphragm portion of the single top steam compressor governor, and a body or valve

the diaphragm portion, but the diaphragm valve 33 will remain until main reservoir pressure reaches that for which the regulating spring 19 is adjusted, when the valve will unseat, allowing air to flow to the top of the piston 6. The piston is thereby moved downward, opening valve 5 (at the left) and allowing main reservoir air to flow direct to the parasite res-

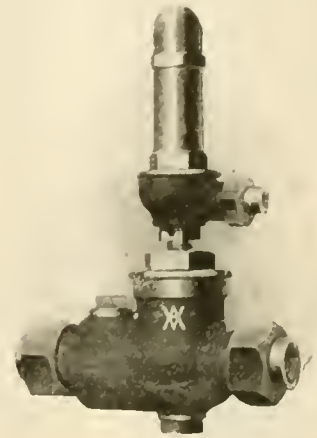

PARASITE RESERVOIR GOVERNOR.

ervoir past the non-return check 5 (at the right).

When the air is being taken from the parasite reservoir for the operation of the parasites, the pressure will fall a like amount in both reservoirs until it reaches that for which the governor head is set, when diaphragm valve 33 will seat and prevent further flow of air from the main reservoir.

Should the pipe between this governor and the parasite reservoir break, air in the main reservoir will not be lost, because the diaphragm valve will seat as soon as the pressure in the parasite reservoir drops to that for which the regulating spring is set. Should a main reservoir pipe break, the non-return check valve 5

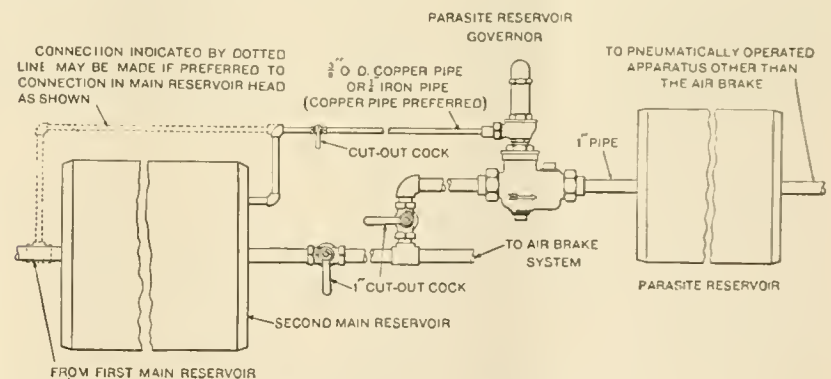

DIAGRAMMATIC VIEW OF APPLICATION OF PARASITE RESERVOIR GOVERNOR.

portion which embodies a piston, a spring valve and a non-return check valve. Pipe connections are made, as illustrated, from the main reservoir to the diaphragm portion and to the body portion and also from the parasite reservoir to the body portion.

When charging the parasite reservoir, air will flow from the main reservoir to

(at the right) will prevent the loss of parasite reservoir air.

From the foregoing it is apparent that in addition to the primary function of protecting the brake system against the depletion of air supply due to the use of parasite apparatus, this governor also prevents the loss of air from both reservoirs if the air supply should be reduced from

any other cause, as from the use of the air brake, or from breakage of pipe connected to either reservoir. Thus should the parasite reservoir pipe break, or the pressure become reduced abnormally through operation of the parasites, the Parasite Reservoir Governor would prevent the loss of main reservoir air below a point necessary for the operation of the brakes. Furthermore, should main reservoir pressure be lost through the breakage of main reservoir pipe, or be reduced abnormally from any other cause, the Parasite Reservoir Governor would prevent the loss of parasite reservoir pres-

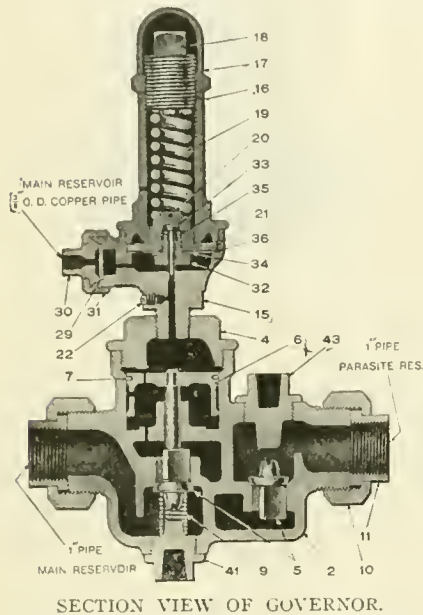

SECTION VIEW OF GOVERNOR.

sure, thereby making it possible to reverse the engine if provided with a pneumatic reverse gear or to operate the other parasite apparatus.

#### Beautiful Railroad Cars.

Referring to our article on page 311 of the September issue, we are indebted to the kindness of Henry F. Colvin of Philadelphia for the following description of the first railroad sleeping car.

The cars intended for night traveling between this city and Philadelphia, and which afford berths for 24 persons in each, have been placed on the road, and will be used for the first time tonight. One of these cars has been brought to this city, and may be inspected by the public today. It is one of the completest things of the kind we have ever seen, and is of beautiful construction. Night traveling on a railroad is, by the introduction of these cars, made as comfortable as that by day, and is relieved of all irksomeness. The enterprise which conceived and constructed the railroad between this city and Philadelphia, cannot be too highly extolled, and the anxiety evinced by the officers who now have its control, in watching over the comfort of the passengers, and the great expense incurred for that

object, are worthy of praise, and deserve, and we are glad to find receive, the approbation of the public. A ride to Philadelphia now, even in the depth of winter, may be made without inconvenience, discomfort, or suffering from the weather—you can get into the cars at the depot in Pratt-street, where is a pleasant fire, and in six hours you are landed at the depot in Philadelphia! If you travel in the night you go to rest in a pleasant berth, sleep as soundly as in your own bed at home, and on wakening next morning find yourself at the end of your journey, and in time to take your passage to New-York if you are bent there! Nothing now seems to be wanting to make railroad traveling perfect and complete in every convenience, except the introduction of dining cars, and these we are sure will soon be introduced.—*Baltimore Chronicle*, October 30.

[From *American Railroad Journal and Mechanics' Magazine*, November 15, 1838, page 328.]

#### The Elastic Limit.

Many serious accidents happen in shop work through the failure of workmen to appreciate what is known in engineering as initial strain. There are many machinists who are under the impression that the more tightly a thing is screwed up the safer it is, and it is, therefore, desirable to point out that this is not necessarily, nor indeed generally, the case, and often the over-tightening of connections is frequently a source of danger. The danger is caused by screwing up work to such a degree that the breaking point of the connection is approached. In some cases a certain amount of initial strain is necessary to prevent rattling, but the requirement of different classes of work should be carefully considered, and no haphazard method of tightening everything adopted. It is highly important that this matter should be thoroughly understood by the general run of mechanics, for it is not to be supposed that foremen can watch every detail of tightening a nut or key, nor should it be necessary for them to do so.

If the pull upon a bolt is at right angles to its length, there is not the slightest use in initial strain, and it merely needs to be screwed up sufficiently to keep the parts in contact, there being no tendency to displace the bolt or nut longitudinally; but if the pull upon the bolt is longitudinal, some normal stress is necessary to prevent knocking, and the amount of this can easily be determined in each particular case. Let us consider the action of initial stress upon a bolt longitudinally strained, such as the bolt holding the bearing cup of a steam engine. If in such a case, the nut were only screwed up to touch the metal, then when tension comes upon the bolt, it is slightly elongated, thus removing the parts joined from actual

contact; on the cessation of the tension those parts will fly together again, and this action being constantly repeated, knocking will be set up, causing injury to the parts concerned.

If the amount of initial tension upon the bolt is equal to that which can be brought upon it in the course of work, it is evident that in that case the parts held by it will not be separated, as the bolt will be no further extended unless the working stress exceeds the initial stress already upon the bolt. The amount of tension that can be put upon a bolt with an ordinary wrench is very great. The strain thus imparted is frequently sufficient to strain the iron of the bolt beyond the elastic limit.

#### The New Subways in New York.

At the monthly meeting of the New York Railroad Club, held on September 15th, Mr. R. H. Jacobs, senior assistant division engineer of the Public Service Commission, delivered an interesting paper on "The Construction of the New Subways for New York City." Mr. Jacobs showed considerable data proving that the engineering cost of the work was exceedingly low. In regard to the plan, Mr. Jacobs claimed that it is nothing short of magnificent in its conception, overcoming difficulties that none but men of extraordinary vision, faith and courage would ever even attempt to consummate. The cost of the work will be low, due first to the extensive use of existing facilities; second, to the wide and absolutely free competition; third, to the fact that the greater part of the contracts were let before the present advance in the cost of labor and materials, and, fourth, to the low cost of engineering.

#### Improvements in the Chicago, Milwaukee & St. Paul.

The Chicago, Milwaukee & St. Paul contemplate making terminal improvements costing over \$600,000. This will include a 26-stall roundhouse, 90-ft. turntable, 154-ft. cinder pit, a coal handling plant, a power house 50 ft. by 80 ft., a blacksmith and machine shop 50 ft. by 90 ft. by 100 ft., and other buildings, besides an additional yard for increased traffic.

#### Signal Installation on the New York, New Haven & Hartford.

The New York, New Haven & Hartford has recently received from the General Railway Signal Company the material for its electro-mechanical interlocking plant at Rye, N. Y. This plant comprises 32 electric levers (23 working and 9 spare) and 16 mechanical levers (12 working and 4 spare). The machine will be installed by the railroad company's forces.

# Electrical Department

## Catechism of the Electric Locomotive Continued

Last month we considered the electro-pneumatic system of control for electric locomotives and will take up in this issue the design and construction of the electro-magnetic system. Before proceeding with this subject we will discuss the two types of battery circuits or arrangements which are used with the electro-pneumatic system. A different arrangement of circuits are used in alternating current locomotives than are used in direct current locomotives.

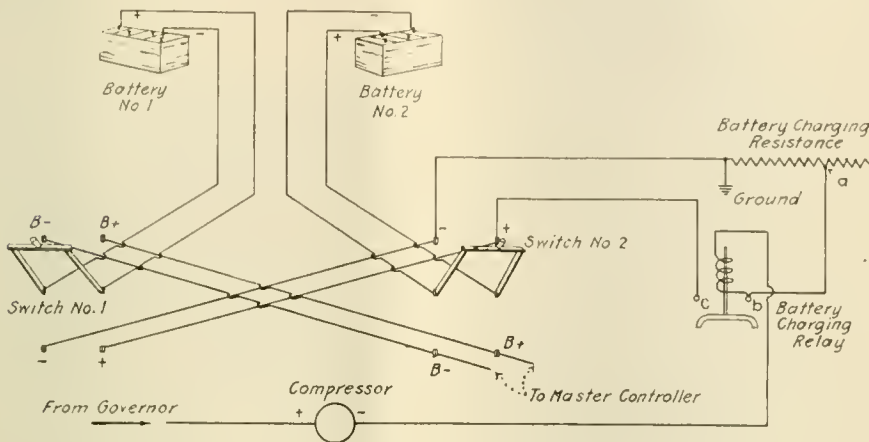

FIG. 15. DIAGRAM OF CONNECTIONS FOR BATTERY CHARGING D. C.

Q. A storage battery is of course limited in a supply of current and how is same re-charged?

A. On D. C. (direct current) locomotives this is easily taken care of by connecting the battery on the ground side across a resistance in the circuit of the motor driven compressor.

Q. What is the arrangement of the circuits?

A. The diagram of connections for battery charging with D. C. operation is shown by Fig. 15. It is noted that the negative side of the compressor is connected to the coil of the relay "B" known as the battery charging relay and from there connection is made to the battery charging resistance. When the governor closes and the compressor operates, the current flowing through the compressor flows through the relay coil to point "a" on the resistance to the ground.

As we know, current flowing through a resistance gives a voltage drop across the resistance and the resistance is so arranged that the point "a" can be moved so as to make the voltage across this resistance suitable for charging the batteries.

The flowing of the current through the coil of the relay energizes same, which lifts the plunger connecting the points

b-c together. The terminals + and - of the two, double-pole, double-throw switches are at a voltage equal to the voltage drop across the resistance since the + terminal is connected to the point "a" and the - terminal to the ground lead.

With this arrangement two batteries are used; one battery connected to each of the double throw switches at the hinged terminals. The other terminals of both switches are marked B + and B -

and down on alternate days, the batteries are kept in first class condition.

Q. Is this same arrangement possible with the batteries on A. C. (alternating current) on the locomotives?

A. No, as the passage of the alternating current through the battery would not charge same, direct current being necessary.

Q. What arrangement is used for charging the battery?

A. A small motor generator set is used. This motor generator consists of a motor directly connected to a generator. The motor is of the alternating current type and is connected to one of the transformer taps of suitable voltage. The generator is of the direct current type and wound so as to give a voltage suitable for charging the battery.

Q. What are the detail connections?

A. The connections are shown by Fig. 16. A tap is taken from a transformer, usually of approximately 110 volts, and it is connected through a line relay to ground. This tap is also connected to one side of a double pole single throw switch. When this switch is closed, the 110 volts is connected to the motor of the motor generator set. The motor operates and will run whenever power is on the transformer. The other side of this switch is connected in the generator circuit—the generator, as mentioned above, supplies current to the battery, charging same. It is noted that the negative side of the generator is connected to the contacts on the line relay which are closed whenever the main transformer is energized. The object of this line relay is to prevent the battery feeding back into the generator, running the generator as a motor when the power is cut off

and connect to the control wires running to the master controller.

With both of the switches in the up position, No. 1 battery would be furnishing the power to the B + and B - wires running to the master controller, while the No. 2 battery would be connected across the battery charging resistance whenever the compressor operated. With the switches both in the down position, No. 1 battery would be connected across

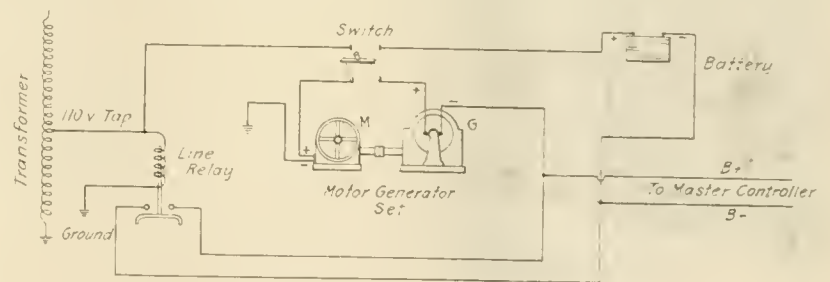

FIG. 16. ARRANGEMENT FOR CHARGING BATTERIES.

the resistance receiving the charging current, while the No. 2 battery would be supplying power for the operation of the control.

Q. What is the object of having the two batteries?

A. This arrangement makes it possible to charge one battery while using the other and by throwing the switches up

from the transformer. If this relay was not in the circuit, the generator would be connected permanently to the battery whenever the switch was closed.

Q. How many batteries are used with this arrangement?

A. It is only necessary to use one battery. The battery, as can be seen from the diagram of connections, is connected

in multiple with the generator, the leads for the control circuits being tapped on as shown. The battery is "floating" on the line and is being charged whenever the power taken for the control is less or equal to that given out by the generator. In other words, the generator supplies the power to the circuits whenever the generator set is running and the battery is only for emergency purposes and to take care of extraordinary drafts or to supply current to the control when the motor generator set is not operating.

**ELECTRO-MAGNETIC SYSTEM.**

The electro-magnetic system has been developed by the General Electric Company as is in use on many of the large direct current locomotives built by this company. For instance the New York Central, Detroit River Tunnel, Baltimore & Ohio, Butte, Anaconda & Pacific locomotives are equipped with this system. Although there may be slight differences in the various equipments, the method of operation is the same and the following illustrations have been chosen to bring out the design and construction of this system.

Q. What is the principle used in the operation of the above system?

A. The power for closing the contacts or switches is obtained from the magnetic pull of a solenoid through which is flowing electric current, and not air pressure as in the electro-pneumatic system.

Q. What and where is this power taken for the operation of the switches?

A. From the main power supply.

Q. What are these circuits called?

A. These circuits are called control circuits since they pass through the master controller and carry small currents.

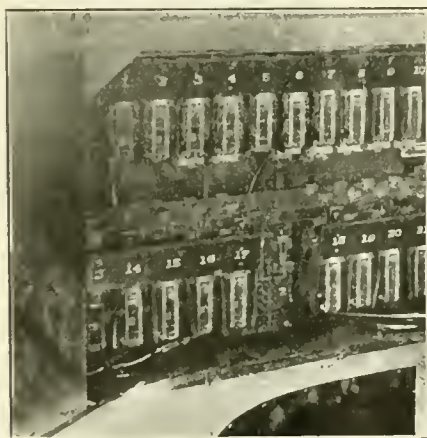

FIG. 17. BANK OF SWITCHES OR CONTACTORS.

Q. How much current passes through these control circuits?

A. This amount varies, depending on the voltage of the third rail and the design and resistance of the solenoid. An average volume would be from 10 to 15 amperes.

Q. What is the general arrangement of the control circuits?

A. A tap is made to the main supply and connected to the master controller. The master controller, composed of fingers and a drum, connects the voltage to wires leading to the solenoids in the switches. The flow of current through the wire coil, or solenoid, creates a mag-

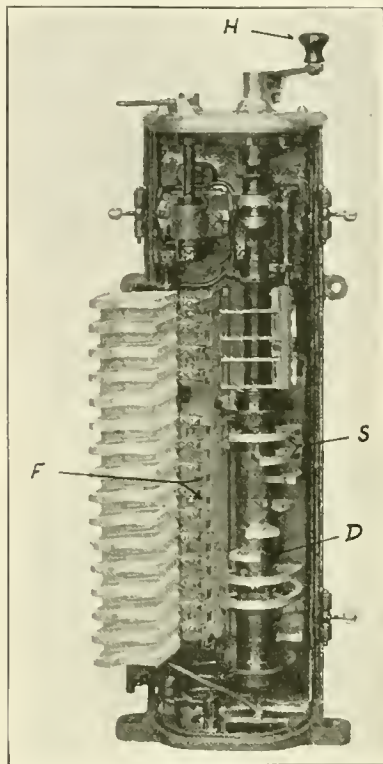

FIG. 18. MASTER CONTROLLER ELECTRO-MAGNETIC SYSTEM.

netic field and the pull of this field is applied to operate and close the switch contacts. The switches are grouped together as shown in Fig. 17.

Q. What is the construction of the master controller?

A. A view of the master controller with cover removed is shown by Fig. 18. It consists of a drum "D" composed of segments "S" which are of greater diameter and arranged so that as the handle "H" is revolved, revolving the drum "D" the segments "S" are brought into contact with the fingers "F." Each finger is connected by a wire to one of the switch solenoids and current passes from the drum through the finger to the solenoid and the switch is closed. As noted in the photo Fig. 18 the segments are so arranged or located on the drum that the switches will be closed in the correct progression and combination to give proper operation of the motors.

Q. What protective features are used in connection with the electro-magnetic controller and why?

A. Arc deflectors "A" are provided to separate each finger from the other. When the controller is in operation the

deflectors "A" are closed so that each finger is isolated in a compartment and any electric arc which may occur between the finger "F" and the segment "S" will be confined to the one compartment and can not spread to adjacent fingers which would be a serious matter.

Another protective feature used is an enclosed fuse in each control circuit. In case of any trouble or failure in one of the control circuits or switch solenoids the fuse will blow, disconnecting the circuit from the power supply. This protection is very necessary with this system. The power for the control circuits as we have seen is taken from the main power supply at, at least, 600 volts. Unless an automatic means was provided to disconnect a circuit which became grounded, the results would be serious.

Q. How does the master controller used with the electro-pneumatic system differ from this one?

A. First place it is smaller. We have seen that with the electro-pneumatic system a small battery of 32 volts is used for the control circuits. This low voltage is the maximum which enters the master controller and the high potential insulation and spacing is not necessary. The controller becomes more compact and the fingers and segments can be made smaller as the current in the control circuits of the electro-pneumatic system is less than an ampere. The large arc deflectors and the fuses are not required.

Q. How are one of these units or contactors constructed?

A. A contactor is shown by Fig. 19 with one side of the arc box removed to show the switch contacts. Referring to this figure there is the coil or solenoid "C," inside of which projects the core or

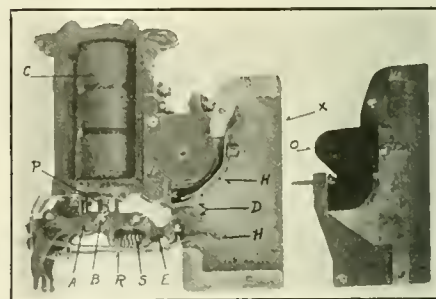

FIG. 19. VIEW OF CONTACTOR WITH ARC SIDE REMOVED.

plunger "P." The lower end of the plunger is connected to the switch arm "A" by the pin "B." The control current flowing through the turns of wire of the solenoid creates a magnetic field which pulls the plunger further into the solenoid, raises the switch arm and brings the contacts "D" together completing the circuit for the main power.

Q. What is the purpose of the spring "S"?

A. The spring is located between the



switch arm "A" and contact piece "E," the latter being movable in relation to the arm. When the plunger "P" is drawn into the solenoid the contacts "D" are brought into contact and as more pull is exerted the spring "S" is compressed giving a rocking motion to the lower contactor. This scheme embodied also in the electro-pneumatic switch is very essential for successful operation. It is clearly seen that with this movable lower contactor the lower contactor is still in contact after the plunger has dropped out a little way, but that the contact has shifted from the heel of the contactor to the front half. When the contactors separate the arc which exists until blown out is at the front part of the contactors and the burning of the copper does not take place on the part of the contactors which are together when the switch is

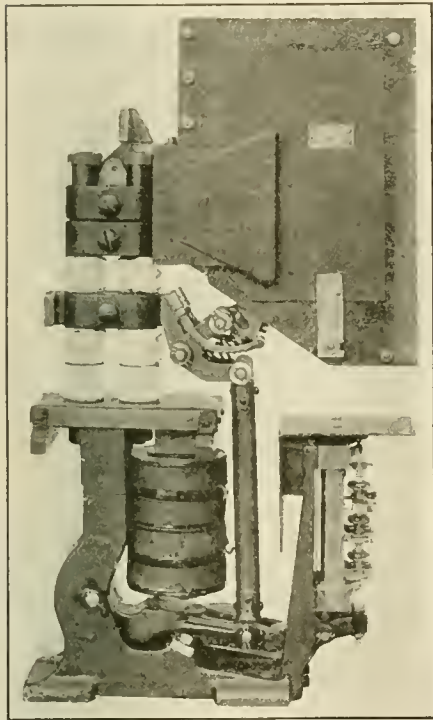

FIG. 20. HIGH VOLTAGE CONTACTOR.

fully closed and through which the main motor current passes. It is necessary to keep the contactors smooth in the fully closed position so that they will not become heated. If the contactors were burned at the heels, small beads of copper would be present and they would not make good contact. With this system the spring also helps to open the switch when the control circuit is interrupted at the master controller.

Q. Are any means provided to extinguish the arc which is formed when the contacts open?

A. Yes. Arcing horns "H" are provided to carry the arc to the front of the arc box "X" and a blow out circuit is provided to blow out the arc electrically. The Fig. 19 shows one side of arc box

removed and also shows the half of blow out coil "O," the other part being located on the far side of arc box shown connected in place on the switch. The blow out coils are connected to the circuit so that current is passing through them at the time the switch opens.

Q. What are the switch shunts and why are they used?

A. The shunts are shown as "R" Fig. 19. They connect the lower contactor to the casting and carry the current around the various pins shown.

A high voltage contactor is shown in Fig. 20. In order to get sufficient insulation the solenoid has been placed below the switch and a wooden rod used from the switch arm to the movable contactor. Porcelain insulators are also used.

#### Interesting Results from "Gripwell."

To begin with, "Gripwell" is the trade name for a very strongly adhesive fluid substance which is used in connection with specially prepared canvas to coat pulleys of iron, wood, paper or fiber. A pulley so treated drives a loose belt with less loss of power than a smooth pulley will drive a tight belt. The reason for this is the practical elimination of all slip between pulley and belt, and the slack belt naturally gives a greater arc of contact than the tight belt. The contact arc for the tight belt is about 170 degs. and that for the loose belt 225 degs. This gives an increase of efficiency of drive of about 20 to 30 per cent. tractive power.

The method of applying "Gripwell" is first to clean the pulley and then paint it, using a brush, with the compound. This thin coating of Gripwell dries very rapidly. A canvas covering cut to fit the surface of the pulley, is liberally coated with Gripwell and the inside surface of the canvas is applied to the dried surface of the pulley. The canvas is worked closely on, and given from four to six hours to dry. If the belt to be used is leather, the Gripwell contains some neatsfoot, and castor oils. These oils are used as a preservative for the leather. If the belt is rubber or canvas the oils are not used.

Two results are immediately apparent where Gripwell is used. The slack belt removes strain on pulley-shaft, and eliminates "hot box" bearings. The slack belt has less stretching strain to deal with. A non-skid automobile tire is used to prevent slipping on a wet pavement and the action of Gripwell is very similar.

Just here it is interesting to observe that adhesion is a physical property of matter entirely apart from "stickiness." It is the force exerted by the molecules of one body upon those of another, and is not chemical affinity, nor is it cohesion, which is the force which holds the particles of a body together, and prevents it falling apart. A lump of chalk placed on

the table does not fall apart or become dust. The particles cohere and hold it intact. Adhesion is where the particles of dissimilar bodies hold closely together when once they are brought in contact, like two sheets of smooth glass, where there is no "stickiness" in the ordinary sense of the word. The manufacturers of Gripwell have succeeded by long and patient experiment, in devising a compound having maximum adhesion without any trace of gumminess. In fact, the friction of two dissimilar bodies, is a kind of loose form of adhesion. Adhesion varies just as friction does. Some substances possess it in a greater degree than others. Gripwell has adhesion in high degree without being gummy or sticky. It therefore does not tend to pick up dust, dirt or other particles due to belt or pulley abrasion, as many forms of anti-slip material do, owing to their sticky quality.

A large eastern gas company recently adopted this pulley covering in the blower room of its plant. The compound was applied September 17, 1915, and after giving it a test for eight months, the company covered four Sturtevant blower fan pulleys. These blower pulleys operate under 500 h. p. and each makes 900 r.p.m. An endless belt, 28 ft. from center to center, connects the driving pulley, 8 ft. in diameter and 24 in. wide, with the driven pulley 24 in. face and 26 in. in diameter. The results have been most satisfactory and the continued use of Gripwell is assured.

A useful, though at first unexpected application of Gripwell came to light not long ago, in which a consulting mechanical engineer was called in to obviate the results of air leaking through loose mortar, cracks and small fissures in a brick boiler setting, for a stationary boiler. The walls of the boiler setting were sized with glue and water, in the usual way. When Gripwell was painted on and a canvas covering lighter than that used for pulleys, was applied. The air leaks at once disappeared, and the uselessly burned fuel due to the air leaks was saved. Roundhouse foremen and others may find here "food for thought" in this fact, when coating pulleys with Gripwell. The Gripwell Pulley Covering Company has now a very interesting booklet on the uses of their product. They will be happy to mail this booklet to anyone applying to them at 157 Cedar street, New York, N. Y.

#### Nickel Plating.

Light nickel plating can be made by heating a bath of pure granulated tin, argol and water to boiling, and adding a small quantity of red-hot nickel oxide. A brass or copper article immersed in this solution is instantly covered with pure nickel.

# Testing Railway Track Scales by Test Cars

By T. HERBERT WADE

## Irregularities in Weight Caused Loss of Revenue—Growth of Test Idea—Form of Cars

Within the past five years the railways of the United States have shown much needed and remarkable activity not only in the installation of new track scales, but in the improvement of methods of maintenance and test. With the increased weight of equipment, and particularly with the construction of cars of greater capacity for bulk commodities, such as coal, ore, limestone, etc., the loads to be weighed on track scales are far greater than previously carried.

Whether the railways built their own scales or purchased them from scale manufacturers, there was a general demand for stronger and more sturdy construction, for greater accuracy, for better foundations and conditions of maintenance and, in short, increased attention was being devoted to every phase of the problem. Where railway scales were tested, so-called test cars were employed which were carefully weighed on master scales on the better equipped roads, and on the latest and sharpest ordinary scales on other roads. With the weight constant and determined as accurately as possible, these test cars were sent over the system and the various track scales were checked. This system was first developed on the Pennsylvania and the cars, as used on this system, have shown steady progress and today represent probably the best construction.

can be lifted out from within the car, placed on the track and then loaded with standard weights of large denomination. These standards, eight of 10,000 lbs. each, four of 2,500 lbs. each, and 10,000 lbs. of 50-lb. weights in boxes, can be lifted out, placed on the truck which weighs about 5,000 lbs. so that the truck can be loaded up to 90,000 lbs. in standard weights which are accurate in the mass to within less



UNLOADING STANDARD TEST WEIGHTS.

than a pound. With this equipment scale engineers of the Bureau of Standards have been able to make a careful survey of railway track scales of the country and not only have determined their present condition but have been able to formulate certain standards of forms to which rail-

rests by means of suspended bearings, and by the compound lever action the force of the load is transmitted to extension levers which communicate with a fifth or transverse lever connecting in turn with the beam of the scale. Thus a counterpoise of 25 lbs. will support a maximum weight of 300,000 lbs., if the total multiplication of the levers employed amounts to 1,200 to 1 with the counterpoise at the end of the beam.

To determine whether a track scale weighs correctly is the function of the inspector with the test car. At the railway scale shop or laboratory there is a master scale whose sensibility reciprocal should not be greater than 5 lbs., that is, the weight required to be placed upon or removed from the platform to turn the beam from a horizontal position of equilibrium in the middle of the trig loop to the position of equilibrium at the top or bottom of the loop should not exceed 5 lbs. for new scales and in the best master scales it is considerably less. The counterpoise weights employed by these master scales and the scales themselves are carefully tested against standard weights so that when the test car is put on the platform an accurate weighing is made. For the inspection tour the test car is carried from place to place, hauled at the rear of the train, and sometimes two cars

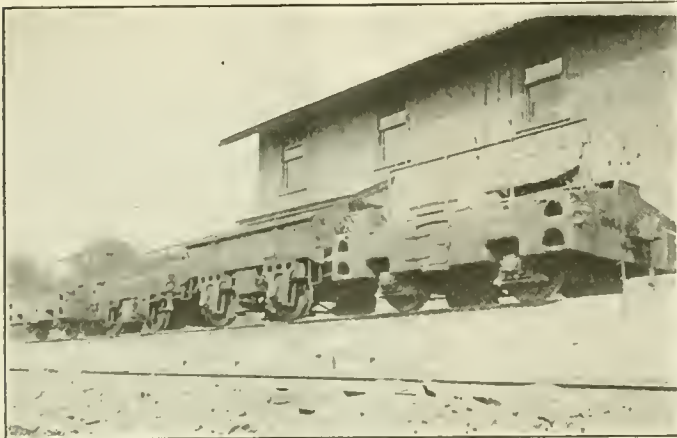

SCALE TEST CARS OF VARIOUS STYLES.

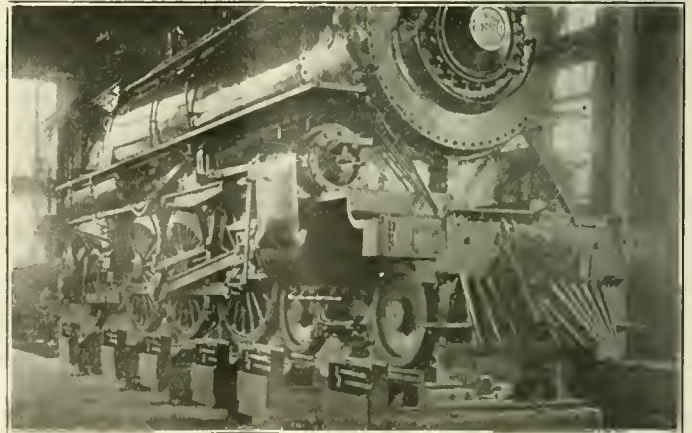

P. R. R. LOCOMOTIVE ON INDIVIDUAL WHEEL SCALES.

The test car of the United States Bureau of Standards, as shown in the illustration, differs somewhat from the regular test car of the railways, inasmuch as a number of refinements have been introduced so that the highest scientific precision is secured. The test car consists of a large box car of the style used for transporting automobiles, supplied with its own gasoline-electric power plant, which is capable of working an extension crane by means of which a small truck

way track scales reasonably should conform.

All of the various types of test weight cars shown in our illustrations are familiar to railway men, but it may be desirable to indicate their use. A railway track scale, though its mechanism is concealed from view, is really very simple. There are usually four or more sets of main levers in the scale pit arranged in pairs transverse to the track. Upon these the bridge construction carrying the rails

of different weight are employed, one heavy and one light, this arrangement being the most important practice in testing large scales. While it is imperative to have test cars of large weight, for the conditions must be reproduced as closely as possible for heavy weight, yet by using a test car with a small wheel base and placing it successfully over the different sections a closer approximation can be had to the conditions of the heaviest loading.

The positions can be varied and it can be seen what part of the scale is at fault and the necessary adjustment can be made. The shorter the wheel base in the car the more accurately is it possible to ascertain the errors of the various sections and, for that reason, one-truck test cars with a wheel base of from 6 to 8 ft. are employed rather than two-truck cars approaching standard length, such as were used at one time on certain railways where an ordinary box car was loaded with a definite amount of pig iron and its weight determined more or less accurately.

A railway scale test car should be self-contained and be of such design and construction that the weight will be constant in order to make rapid and accurate testing possible. A number of different types have been developed. The main features are the all-metal construc-

tion, as wood not only splinters easily but absorbs moisture or dries out; and in the second place, the car should be strong and durable so that it will not require repairs that would alter its weight. To secure this and further, all unnecessary parts are eliminated, and especially ledges and projections likely to collect and hold dirt. All parts must be accessible for inspection and the load should be distributed uniformly on the axles. To limit the effects of wind pressure, which are quite appreciable in testing scales, the surface area is reduced as much as possible or, in other words, the car is low and squatty.

000 to 80,000 lbs. Their importance can be indicated by the fact that the cars are used to test some 383 company track scales and about 1,000 private scales along the lines. These test cars weigh from 30,000 to 80,000 lbs., and the practice of using two scale test cars, one light and one heavy, as followed on this System, is considered good practice and is used on other lines.

The rules of the American Railway Association recommend that scales in regular service shall be tested at least every three months with a test car or test weights up to at least 10 per cent of their rated capacity. When the test cars are weighed on the master scales by competent officials all locks are sealed so that the weight cannot be changed until the car returns to the master scales after its trip. With the exception of a tool box in which two pinch bars are carried, no

light and the same errors persist they proceed to adjust the scale, unless the errors are so large as to imply that it should be taken to the factory. If the readings are uniformly high or low, by moving the nose irons at the fifth lever the adjustment can be made. If there is a variation in readings when the test-weight car is over the different portions of the scale, different sections must be considered individually. By grinding a knife edge or pivot with a portable emery wheel the short arm or lever may be altered in length so as to bring the proper adjustment. For example, a grinding of 1/100 of an inch in the main lever with a 10-inch fulcrum will make a change of about 200 lbs. on the weigh-beam, whereas a movement of about 1/2-inch of the nose iron would be required to make the same change at the weigh-beam.

Quite distinct from the testing of track scales is the weighing of locomotives as done in the shop. With heavier weights of locomotives the determination and distribution of weight must be considered as they figure in problems connected with bridges and road bed. Of course, a locomotive can be run on an ordinary track scale of large capacity, if such a scale is adequate for its weight, but often the distribution of the weight on the various axles and wheels is particularly important. Accordingly, in a locomotive shop, and especially with a new locomotive, it is usual to employ special locomotive scales in order to determine this distribution. Our illustration shows a locomotive being weighed by such scales, it being evident that the weight on each axle is being transmitted to a separate scale of the ordinary beam type, which has been carefully calibrated and which is capable of weighing with a high degree of precision. These scales support the locomotive, which is raised upon them by means of an overhead crane or jacks.

Another type of locomotive scale deals not only with the weight on each axle but the weight on each wheel. This can be used with ordinary track provided there is a concrete base filling under and between the ties and at each side of the track wide enough for the scales, and finished level with the side of the rail. The wheel-bearing surface of the end of the scale can be inserted under the wheel and then by means of appropriate screws the bearing pivot under the wheel can be raised above the rail surface to a height of 1/16 of an inch above the head of the rail and the tread of the wheel and with the flange of the wheel 1/8 of an inch distant from the rail. All the wheels can be raised clear of the track and then the weighing carried on by means of the levers, using proportionate counterpoises and sliding the poise of the beam until balanced. The results when tabulated are of considerable value.

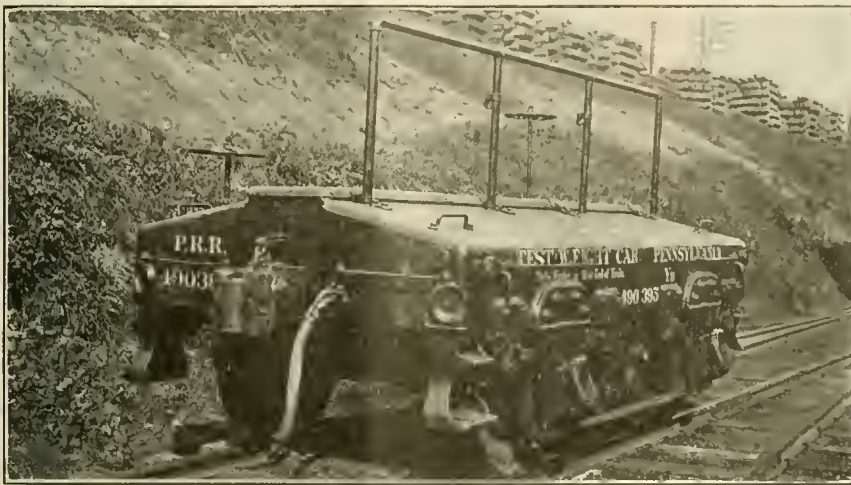

P. R. R. TEST WEIGHT CAR FOR USE ON THE ROAD.

food, supplies, tools, or any other loose material is transported and even if the seals of the tool box are broken, the contents must be replaced and resealed by the inspectors. In some cases the test cars may carry loose in compartments 50-lb. standard weights which are used in testing other scales, such as platform or cattle scales, but where the test car is used for track scales exclusively the various compartments are ordinarily locked and sealed. Where one test car is used in testing a scale, the scale is balanced with the test car, placed on it as near one end as possible. If the scale balances at the actual weight of the test car it is then moved over the next section of the scale and the weight, as indicated by the beam, is again noted. With the weight beam indicating the correct weight at each of the 4, 5, or 6 sections, the scale is assumed to be correct, as is also the case if the various readings come within the permissible tolerance, but if a greater error is shown, the scale inspectors look first to see whether there is any binding in the scale parts and if all the parts are in their proper places. If nothing is brought to

On the Pennsylvania System a complete circuit takes a test car from 6 to 8 weeks after which it is returned to the scale shops at Altoona for correction, cleaning and repairs. The weight, however, on a suitable car, varies but little and one car used on the Pennsylvania System made seven trips aggregating 10,000 miles, much of which was in the winter months, without varying more than 10 lbs. This road now has 17 scale cars in service, varying in capacity from 30,-

# Discretionary Obedience Applied to Railway Signals

Method of Applying Permissive Blocking on Heavy Grade. Signals Arranged and Obeyed So as Not to Delay Traffic. Good Judgment and Common Sense Expected in the Operating of Trains.

The Delaware, Lackawanna & Western Railroad have installed some signals which permit of a form of permissive blocking, or as it has otherwise been called "discretionary obedience." This means that an engineman is permitted to use his judgment under certain circumstances, without in any way decreasing his responsibility.

The circumstances where this form of permissive blocking is in vogue is

The following bulletin has been issued by the company to deal with this state of affairs:

"Eastward home and distant signal K-4134, located just east of the Erie and Black Rock crossing, and westward single arm home signal K-4124, located 8-10 mile east of the same crossing, will display a yellow or caution home blade by day and a yellow light by night. When the blade is in the hori-

that they are now in regular service."

This procedure represents a practical attempt to deal with a special situation. The blades of both semaphores are painted yellow, which indicates their permissive character. The "home" blade has a square end and the "caution" blade has a fishtail end. No red signal is used night or day because a halt on the road is not obligatory. This arrangement does not require an en-



D. L. & W. SIGNALS OPERATED ON THE PERMISSIVE PLAN.



D. L. & W. BLOCK SIGNALS ON GRADE.

on the Black Rock branch of the Buffalo division. It consists of an up grade of between 45 to 70 ft. to the mile. In going up this grade signals separate the distance into blocks in the usual manner. A train proceeding up grade turns the signals to "stop" behind it, and a following train, usually full loaded and heavy, is permitted to pass the signal set at "stop" rather than halt on the grade where a start would be difficult if not impossible without the aid of a pusher engine. There is in all about 30 miles of such signaling; the maximum grade is 79 ft. to the mile.

zontal position or a yellow light is displayed, enginemen may proceed under absolute control to the next block ahead, without stopping at the signal."

"Enginemen of any train entering a block under this restrictive indication, as provided by the rules, will be held responsible in case of any accident on account of the block being occupied. These signals will be operated in accordance with rules governing use and operation of automatic block and interlocking signals, which became effective December 16, 1900. The placing of the blades on the signal masts will indicate

engineman to pass or disregard a red signal, which is, or should be, the railroad imperative stop.

As a matter of fact a "home" signal in the "stop" position is not of necessity an order to halt. Custom and good practice require the stop to be made; hence the red color usually employed. The real function of the signal is to give notice of the occupancy or the "clearness" of the block ahead. The "caution" signal indicates the condition of the block next ahead. The stop is proper and advisable, but the signal is more of an information-giver to the men

on the road rather than a director of behavior.

To stop a heavy train on an up-grade would entail a hard or difficult start, and on this portion of the D., L. & W. the warning is given by the horizontal yellow blade in the day and by the yellow light at night. To proceed under these circumstances does not necessarily involve danger, but the responsibility to have the train under full control and to be on the watch for a sudden stop rests squarely on the shoulders of the engineer. The signal here described is used in a limited territory and under abnormal conditions. It recognizes the ability of the engineer to use judgment and common sense, and its justification is contingent upon the clearness with which the engineer perceives his responsibility and his faithfulness in obeying the spirit of the directions, and the placing of safety above and beyond all other considerations.

**Heat Phenomena.**

The mechanical theory of heat, as it is now well understood, existed, as a speculation, from the days of the earliest philosophers. The contest which raged with much intensity, and sometimes acrimony, among speculative men of science, during the last century, was merely a repetition of controversies of which we still find evidences, at intervals, throughout the whole period of recorded history. The closing period of last century, which brought about an important revolution in science, marked the beginning of immense discoveries in heat phenomena. It was inaugurated by the introduction of experimental investigation devoted toward the crucial point of the question at issue. It terminated, about the middle of the century, with the acceptance of the general result of such experiments by every scientific man of acknowledged standing on both sides of the Atlantic.

The doctrine long believed, that heat was material, and its transfer a real movement of substance from the source to the receiver of heat, was thus finally superseded by the theory, now become an ascertained truth, that heat is a form of energy, and its transformation a change in the location and method of molecular vibration.

The science of thermodynamics has for its essential basis the established fact of the dynamical nature of heat, and the fact of the greater volume of two forms of energy—heat and mechanical motion, molecular energy and mass energy. Resting as it does upon fundamental, experimentally determined principles, it could have no existence until, during the early part of last century, these phenomena and these truths were well investigated and firmly established.

**Spring Nut Lock  
Machines Stamp 3,000 an Hour**

The Spring Nut Lock Company of Chicago has completed arrangements for placing on the market a spring nut lock which has been given the most rigorous tests, notably by the superintendent of motive power and machinery of the Chicago & Northwestern railroad. As shown in the accompanying illustrations, the device consists of two octagonal plates of thin steel stamped out of one piece, leaving a joint on one of its eight sides. Circular holes to fit the required size of bolt are punched in each plate, and the plate is then bent over until the two holes are almost parallel, one hole overlapping the

rest users of the device not only in motive power and rolling stock, but in roadbed rail plates, frogs and switches and all mechanical appliances that rely for safety on the bolts and nuts that keep them in place. It has been found to be readily applicable to any size of bolt, no matter what the pitch or number of threads to the inch may be.

**Apprentice Machinists.**

Mr. C. W. Griffith of the Santa Fe, writing of apprentice machinists, advises boys before becoming an apprentice to endeavor to get a job in a machine shop or at some work along that line for a few months to see if they like the work and take an interest in it. If so, then it is time for them to begin their apprenticeship, and nine times out of ten they will make a success of their chosen trade.

The probation period which some roads have adopted is a very good idea, for the boy as well as for the road. The first six months is considered a probation period, during which time the instructors give the apprentice special care and attention. If he is an industrious boy and shows a tendency to learn the trade, he is allowed to finish his apprenticeship; but, if he takes no interest in his work and does it in a slipshod way, he is of no benefit to himself or his company, so he is dismissed from the service. This is the best that could be done with him, for, if he should be allowed to continue his apprenticeship, he would make but a failure of himself and be a detriment to his company.

To be a successful apprentice, you must be industrious, take an interest in your work, stay home at nights, be polite to your superior officers and to your fellow workmen, do your work well and always present a neat appearance.

**Railway Construction in Russia.**

A commission has been appointed by the Russian Government to provide for a systematic increase annually of the various railway systems for the next five years of 3,950 miles per year, 2,650 miles to be constructed by the State, and 1,300 miles by private enterprise. The estimates amount to \$116,000 per mile. These extensions will be begun next year. The total railway mileage in the Empire at present amounts to 36,700 in European Russia, and 7,300 miles in Asiatic Russia.

**To Solder Small Castings.**

Clean the surfaces of the fracture with a file, then take a piece of wrought iron and clean it also by filing. Place the piece of wrought iron in the fracture, wire the parts together and braze with spelter solder, using borax as a flux.

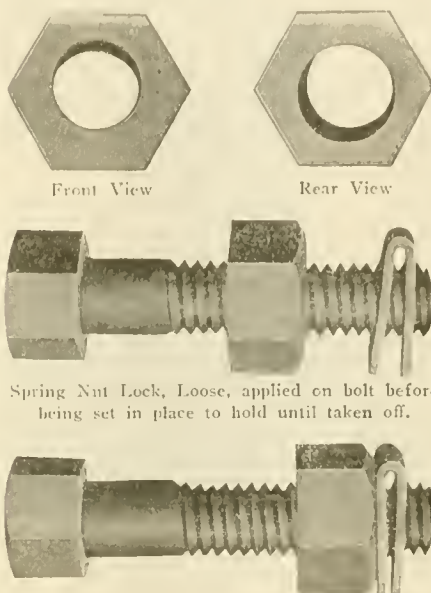

other hole by a mere fraction of an inch. When tempered it acts as a powerful spring, and when slipped on the bolt both legs engage the thread of the screw, the holes in each of the legs being brought into perfect alignment. This has the effect of a pulling force on one of the legs and a pushing force on the other leg, the pulling force being in the valley of the thread on the side of the bolt farthest from the spring, while the pushing force is exerted on the side of the bolt that is nearest to the spring. When tightened into place next to the nut, these opposing forces hold like a vise.

The necessary machines are already at work in the extensive plant of the Stowell Company of South Milwaukee, Wis., and the locks are being turned out in the various sizes most generally used. The machines have a capacity of stamping 3,000 spring nut locks every hour, and in a short time the company plans to produce locks to fit every standard or special size of bolts. It is confidently expected that the railroads eventually will be the great-

# Items of Personal Interest

Mr. J. Hawkins has been appointed road foreman of engines of the Canadian Northern, with office at Rideau Junction, Ont.

Mr. William Gruys has been appointed foreman of the Atchison, Topeka & Santa Fe at Waynoka, Okla., succeeding Mr. J. J. Wagner.

Mr. T. T. Ryan has been appointed foreman of the Atchison, Topeka & Santa Fe at Las Vegas, N. M., succeeding Mr. T. G. Eyans.

Mr. W. N. Ingram has been appointed acting master mechanic, district No. 5, of the National Transcontinental at Edmundston, N. B.

Mr. C. S. Blackwell has been appointed foreman of the Atchison, Topeka & Santa Fe, with office at Deming, N. M., succeeding Mr. N. H. Kushera.

Mr. S. D. Mores has been appointed resident engineer of the Southern, with offices at Spartanburg, S. C., succeeding Mr. L. G. Wallis, resigned.

Mr. J. A. Rasiner has been appointed master mechanic of the Chicago, Aurora & De Kalb, with office at Aurora, Ill., succeeding Mr. W. E. Jones.

Mr. C. W. Warner, formerly assistant general foreman of the Erie at Dunmore, Pa., has been promoted to the position of general foreman at Dunmore.

Mr. C. H. Norton, formerly master mechanic of the Erie at Avon, N. Y., has been transferred to a similar position on the same road at Susquehanna, Pa.

Mr. I. H. Drake has been appointed master mechanic of the Atchison, Topeka & Santa Fe, with office at Clive's, N. M., succeeding Mr. H. Selfridge, resigned.

Mr. W. T. Cousley has been appointed division car foreman of the Galveston, Harrisburg & San Antonio at El Paso, Tex., succeeding Mr. H. Allen, resigned.

Mr. Y. B. Randolph, formerly assistant to superintendent of the Erie at Susquehanna, Pa., has been appointed inspector of locomotives, with office at New York.

Mr. E. T. Du Pue, formerly shop superintendent of the Erie at Galion, Ohio, has been transferred to a similar position on the same road at Susquehanna, Pa.

Mr. A. J. Davis, formerly general foreman of the Erie at Hornell, N. Y., has been appointed assistant master mechanic on the same road, with office at Hornell, N. Y.

Mr. B. V. Somerville, formerly principal assistant engineer of the Pennsylvania Lines West, has been appointed resident engineer, with offices at Detroit, Mich.

Mr. W. F. Scott, formerly charge hand in the erecting shop of the National Transcontinental, has been appointed

foreman of the erecting shop at Transcona, Man.

Mr. H. C. Huckins, formerly roundhouse foreman on the Chicago & Eastern Illinois, has been appointed general foreman on the same road, with office at Salem, Ill.

Mr. H. H. Harrington, formerly shop superintendent of the Erie at Susquehanna, has been appointed to a similar position on the same road, with office at Galion, Ohio.

Mr. H. A. Hillman, formerly roundhouse foreman of the Erie at Cleveland, Ohio, has been appointed general foreman on the same road, with office at Hornell, N. Y.

Mr. C. A. Wheeler, formerly locomotive foreman of the Canadian Pacific at MacTier, Ont., has been appointed locomotive foreman on the same road, with office at Ottawa, Ont.

Mr. D. D. Coleman, formerly general foreman of the Erie at Jersey City, N. J., southside roundhouse, has been appointed assistant master mechanic on the same road at Jersey City, N. J.

Mr. W. F. Harris, formerly general foreman of the Baltimore & Ohio Southwestern at Storrs, Ohio, has been appointed master mechanic on the same road, with office at Flora, Ill.

Mr. F. G. Wallace, formerly general foreman of the Erie at Dunmore, Pa., has been appointed master mechanic on the same road, with office at Avon, N. Y., succeeding Mr. C. H. Norton.

Mr. O. C. H. Waterman has been appointed day engine house foreman on the Cleveland, Cincinnati, Chicago & St. Louis, with office at Rightwood, Ind., succeeding Mr. J. D. Brandon, resigned.

Mr. G. Twist, formerly district master mechanic of the Canadian Pacific at Winnipeg, Man., has been appointed district master mechanic at Medicine Hat, Alta., succeeding Mr. A. West, transferred.

Mr. H. E. Greenwood, formerly master mechanic of the Baltimore & Ohio Southwestern at Seymour, Ind., has been appointed master mechanic at Chillicothe, Ohio, succeeding Mr. P. H. Reeves.

Mr. J. A. Cooper, formerly supervisor of locomotive service of the Erie at Huntington, Ind., has been appointed inspector of locomotive service on the same road, with office at Youngstown, Ohio.

Mr. L. M. Granger, formerly general foreman of the Erie at Susquehanna, Pa., Outside Terminal, has been appointed general foreman of the southside roundhouse of the same road at Jersey City, N. J.

Mr. A. West, formerly district mechanic of the Canadian Pacific at Medicine Hat, Alta., has been appointed dis-

trict master mechanic at Edmonton, Alta., succeeding Mr. A. J. Ironsides, transferred.

Mr. A. K. Galloway, formerly master mechanic of the Baltimore & Ohio at Baltimore, Md., has been appointed general master mechanic of the northwest district, and the Cincinnati, Hamilton & Dayton.

Mr. J. E. Quigley, formerly master mechanic of the Baltimore & Ohio Southwestern at Flora, Ill., has been appointed master mechanic on the same road at Seymour, Ind., succeeding Mr. H. E. Greenwood.

Mr. W. H. Malone, formerly assistant superintendent of locomotive performance of the St. Louis & San Francisco at Springfield, Mo., has been appointed superintendent of locomotive performance at the same place.

Mr. John H. Schroeder has been appointed foreman of passenger car repairs of the Delaware, Lackawanna & Western at Kingsland, N. J. Mr. Schroeder has been in the employ of the Lackawanna over twenty-four years.

Mr. P. O. Wood, formerly superintendent of locomotive performance of the St. Louis & San Francisco, has been appointed assistant general superintendent of motive power on the same road, with offices at Springfield, Mo.

Mr. S. Illingsworth, formerly night locomotive foreman of the Canadian Pacific at Lambton, Ont., has been appointed locomotive foreman on the same road, with office at MacTier, Ont., succeeding Mr. C. A. Wheeler, transferred.

Mr. N. V. Porter, formerly chief clerk to the division storekeeper of the Wabash, with office at Decatur, Ill., has been appointed division storekeeper on the line between Danville, Ill., and Toledo, Ohio, succeeding Mr. E. L. Ensel, resigned.

Mr. E. P. Poole has been appointed supervisor of tool equipment and piece-work on the Baltimore & Ohio, and the position of supervisor of machine and hand tools has been abolished, the duties of this office being now handled by Mr. Poole.

Mr. R. E. Jackson, formerly master mechanic of the Virginia railway at Victoria, Va., has been appointed superintendent of motive power on the same road, with offices at Princeton, W. Va., succeeding Mr. F. T. Slayton, assigned to other duties.

Mr. C. O. Ryborg and Mr. E. C. Lisle, formerly signal inspectors of the Pennsylvania Lines West, have been temporarily assigned to special work, and signal foremen. Mr. H. F. Einsisk and Mr. A. B. Eyster have been appointed acting signal inspectors.

Mr. R. A. Pyne, formerly superintendent of shops of the Canadian Pacific at Winnipeg, Man., has been appointed superintendent of motive power of the Eastern lines of the same road, with offices at Montreal, Que., succeeding Mr. D. T. Main, transferred.

Mr. Robert S. Parsons, formerly chief engineer of the Erie, has been appointed assistant to the president and chief engineer. Mr. Parsons is a graduate of Rutgers College and entered the railway service in 1895 as a transitman on the New York division of the Erie, since which he has occupied various positions, chiefly in the engineering department, all with marked credit and ability.

Mr. L. S. Worthmuller has been appointed signal supervisor of the St. Louis terminal division of the Missouri Pacific system, succeeding Mr. L. R. Mann, promoted. Mr. W. L. Whittington has been appointed acting signal supervisor of the eastern division. Mr. L. R. Mann has been general signal inspector with headquarters at St. Louis, Mo., and Mr. F. E. Baugh has been appointed assistant general signal inspector, with office also at St. Louis.

At the recent annual meeting of the stockholders of the U. S. Light & Heat Corporation the following board of directors were elected: Egbert H. Gold, J. Allan Smith, Ralph C. Caples, Henry W. Farnum, A. Henry Ackermann, Chauncey L. Lane, Keene H. Addington, James A. Roberts, Conrad Hubert, George G. Shepard, and Edwin K. Gordon. The vote of confidence in favor of the present management was 371,079 out of 425,245 votes cast.

At the last meeting of the board of directors of the Lima Locomotive Corporation, Mr. W. E. Woodard was elected vice-president in charge of engineering and designing, with office at Lima, Ohio. Mr. Woodard was born in Utica, N. Y., in 1874, where he attended the public schools. He graduated at Cornell University with a degree of Mechanical Engineer in 1896, after which he was engaged in laboratory and road testing with the Baldwin Locomotive Works. In 1897 he entered the shop and drawing office of the Dickson Locomotive Works as elevation man. In 1900 he went with the Schenectady Locomotive Works, which afterwards became part of the American Locomotive Co., in whose employ he has been up to the present time. While with the American Locomotive Co. he was employed in various capacities as follows: Calculator, chief calculator, including road testing, chief draughtsman, assistant mechanical engineer, manager of the electric locomotive and truck department, and when the truck business was abandoned, he became assistant chief engineer. As assistant chief engineer he had supervision over the drawing office at Schenectady, N. Y. Mr. Woodard's work has

given him opportunity to make an extensive study of the development and the needs of the modern American locomotive. That he made good use of his opportunities is demonstrated by the number of patents granted to him. Mr. Woodard's patents concern car and locomotive devices that are in common use today. These patents are, lateral motion driving box and axle, constant resistance engine truck, throttle pipe and lever, plate frame car trucks, car body height adjuster, lateral motion bolster for car and tender trucks. Mr. Woodard is widely known in the engineering profession. He is a member of the American Society of Mechanical Engineers, the



W. E. WOODARD

New York Railroad Club and the Engineers of Eastern New York.

#### Master Car Builders' Association Committees and Subjects for 1917.

A list of standing and special committees and the subjects submitted to them for the convention of 1917, with instructions for preparation of reports has been issued by the Executive Committee. In order that the reports can be printed and advance copies furnished to the members the reports must be in the office of the Secretary, Karpen Building, Chicago, not later than April 15. Reports arriving later will be referred to the Executive Committee to decide whether the report shall be submitted to the convention. The following are the lists of subjects chosen for reports and the names of committees selected to report on the same:

##### STANDING COMMITTEES.

1. Arbitration: J. J. Hennessey (Chairman), M. C. B., C. M. & St. P. Ry., Milwaukee, Wis.; T. W. Demarest, S. M. P., Penna. Lines, Ft. Wayne, Ind.; Jas. Coleman, S. C. D., Grand Trunk Ry., Montreal, Can.; F. W. Brazier, S. R. S., N. Y.

C. R. R., New York City; T. H. Goodnow, A. S. C. D., C. & N. W. Ry., Chicago, Ill.

2. Standards and Recommended Practice: T. H. Goodnow (Chairman), A. S. C. D., C. & N. W. Ry., Chicago, Ill.; C. E. Fuller, S. M. P., Union Pacific R. R., Omaha, Neb.; A. R. Ayers, Engr. R. S., N. Y. C. R. R., New York City; O. C. Cromwell, M. E., Balto. & Ohio R. R., Baltimore, Md.; O. J. Parks, G. S., German-American Car Lines, Chicago, Ill.; R. E. Smith, G. S. M. P., Atlantic Coast Line R. R., Wilmington, N. C.; C. F. Thiele, G. C. I., Penna. Lines, Columbus, Ohio; A. G. Trumbull, Asst. to G. M. S., Erie R. R., New York City.

3. Train Brake and Signal Equipment: R. B. Kendig (Chairman), G. M. E., N. Y. C. R. R., New York City; B. P. Flory, S. M. P., N. Y. O. & W. R. R., Middletown, N. Y.; J. M. Henry, Asst. Div. Supt., Penna. R. R., Youngwood, Pa.; L. P. Streeter, Air Brake Engr., Ill. Cent. R. R., Chicago, Ill.; R. B. Rasbridge, S. C. D., Phila. & Reading Ry., Reading, Pa.; W. J. Hartman, Air Brake Inst., C. R. I. & P. Ry., Chicago, Ill.; G. H. Wood, G. A. B. I., A. T. & S. F. Ry., Topeka, Kan.

4. Brake Shoe and Brake Beam Equipment: C. D. Young (Chairman), Eng. Tests, Penn. R. R., Altoona, Pa.; Prof. Chas. H. Benjamin, Purdue University, Lafayette, Ind.; R. B. Kendig, G. M. E., N. Y. C. R. R., New York City; C. B. Young, M. E., C. B. & Q. R. R., Chicago, Ill.; C. H. Bilty, M. E., C. M. & St. P. Ry., W. Milwaukee, Wis.; G. H. Gilman, M. C. B., Nor. Pac. Ry., St. Paul, Minn.; T. J. Burns, S. R. S., Mich. Central R. R., Detroit, Mich.

5. Couplers: R. L. Kleine (Chairman), C. C. I., Penna. R. R., Altoona, Pa.; G. W. Wildin, M. S., N. Y. N. H. & H. R. R., New Haven, Conn.; F. W. Brazier, S. R. S., N. Y. C. R. R., New York City; F. H. Stark, Supt. R. S. Montour R. R. Co., Coraopolis, Pa.; A. E. Manchester, S. M. P., C. M. & St. P. Ry., W. Milwaukee, Wis.; J. W. Small, S. M. P., S. A. L. Ry., Portsmouth, Va.; J. A. Pilcher, M. E., N. & W. Ry., Roanoke, Va.

6. Loading Rules: A. Kearney (Chairman), A. S. M. P., N. & W. Ry., Roanoke, Va.; A. B. Corinth, G. C. I., A. C. L. R. R., Wilmington, N. C.; L. H. Turner, S. M. P., P. & L. E. R. R., Pittsburgh, Pa.; R. L. Kleine, C. C. I., Penna. R. R., Altoona, Pa.; J. M. Borrowdale, S. C. D., Ill. Cent. R. R., Chicago, Ill.; C. N. Swanson, S. C. S., A. T. & S. F. Ry., Topeka, Kan.; H. C. May, S. M. P., C. I. & L. Ry., Lafayette, Ind.; E. J. Robertson, S. C. D., Soo Line, Minneapolis, Minn.

7. Car Wheels: W. C. A. Henry (Chairman), S. M. P., Penna. Lines, Columbus, Ohio; A. E. Manchester, S. M. P., C. M. & St. P. Ry., Milwaukee, Wis.;

C. W. Van Buren, G. M. C. B., Can. Pac. Ry., Montreal, Can.; J. A. Pilcher, M. E., N. & W. Ry., Roanoke, Va.; O. C. Cromwell, M. E., B. & O. R. R., Baltimore, Md.; J. M. Shackford, C. D., D. L. & W. R. R., Scranton, Pa.; H. E. Smith, Engr. Tests, N. Y. C. R. R., Collinwood, Ohio; C. T. Ripley, G. M. I., A. T. & S. F. Ry., Chicago, Ill.; F. T. Slayton, S. M. P., Virginian Ry., Princeton, W. Va.

8. Safety Appliances: C. E. Chambers (Chairman), S. M. P., C. R. R. of N. J., Jersey City, N. J.; D. R. MacBain, S. M. P., N. Y. C. R. R., Cleveland, Ohio; D. F. Crawford, G. S. M. P., Penna. Lines West, Pittsburgh, Pa.; C. E. Fuller, S. M. P., Union Pac. Ry., Omaha, Neb.; C. B. Young, M. E., C. B. & Q. R. R., Chicago, Ill.; H. Bartlett, G. S. M. P., B. & M. R. R., Boston, Mass.; E. A. Sweeley, M. C. B., S. A. L. Ry., Portsmouth, Va.; H. T. Bentley, S. M. P., C. & N. W. Ry., Chicago, Ill.

9. Car Construction: W. F. Keisel, Jr. (Chairman), A. M. E., Penna. R. R., Altoona, Pa.; A. R. Ayres, Engr. R. S., N. Y. Central R. R., New York City; C. E. Fuller, S. M. P., Union Pacific R. R., Omaha, Neb.; E. G. Chenoweth, M. E., C. R. I. & P. Ry., Chicago, Ill.; J. C. Fritts, M. C. B., D. L. & W. R. R., Scranton, Pa.; C. L. Meister, M. E., Atlantic Coast Line R. R., Wilmington, N. C.; H. T. Bentley, S. M. P., C. & N. W. Ry., Chicago, Ill.

10. Specifications and Tests for Materials: C. D. Young (Chairman), Engr. Tests, Penna. R. R., Altoona, Pa.; J. R. Onderdonk, Engr. Tests, Balto. & Ohio R. R., Baltimore, Md.; J. J. Birch, D. C. I., Norfolk & Western Ry., Roanoke, Va.; I. S. Downing, G. M. C. B., C. C. C. & St. L. Ry., Indianapolis, Ind.; Frank Zeleny, Engr. Tests, C. B. & Q. R. R., Aurora, Ill.; A. H. Feters, M. E., Union Pacific Ry., Omaha, Neb.; H. B. MacFarland, Engr. Tests, A. T. & S. F. Ry., Chicago, Ill.; G. S. Sprowle, S. M. P., A. C. L. R. R., Rocky Mount, N. C.; H. G. Burnham, Engr. Tests, Nor. Pac. Ry., St. Paul, Minn.

#### SPECIAL COMMITTEES.

11. Car Trucks: J. T. Wallis (Chairman), G. S. M. P., Penna. R. R., Altoona, Pa.; E. W. Pratt, A. S. M. P., C. & N. W. Ry., Chicago, Ill.; Jas. Coleman, S. C. D., Grand Trunk Ry., Montreal, Can.; J. J. Tatum, S. F. C. D., B. & O. R. R., Baltimore, Md.; Prof. E. C. Schmidt, University of Illinois, Urbana, Ill.; C. W. Van Buren, G. M. C. B., Can. Pac. Ry., Montreal, Can.; J. McMullen, M. S., Erie R. R., Meadville, Pa.; A. R. Ayres, Engr. R. S., N. Y. C. R. R., New York City; E. G. Chenoweth, M. E., C. R. I. & P. Ry., Chicago, Ill.; J. J. Maginn, G. F. S., Cin. Northern R. R., Van Wert, Ohio.

12. Prices for Labor and Material: P. F. Smith, Jr. (Chairman), S. M. P., Penna. Lines, Toledo, Ohio; G. E. Car-

son, D. M. C. B., N. Y. C. R. R., W. Albany, N. Y.; W. L. Kellogg, S. M. P., M. K. & T. Ry., Denison, Tex.; J. E. Mehan, A. M. C. B., C. M. & St. P. Ry., W. Milwaukee, Wis.; Ira Everett, G. C. I., L. V. R. R., So. Bethlehem, Pa.; Willard Kells, A. G. S. M. P., A. C. L. R. R., Wilmington, N. C.; O. J. Parks, G. S., German-American Car Lines, Chicago, Ill.; H. L. Osman, S. C. D., Morris & Co., Chicago, Ill.; G. F. Laughlin, S. C. D., Armour & Co., Chicago, Ill.; Thos. Beaghen, Jr., M. C. B., Union Tank Line, New York City.

13. Train Lighting and Equipment: J. H. Davis (Chairman), Elec. Engr., B. & O. R. R., Baltimore, Md.; C. H. Quinn, A. E. M. P., N. & W. Ry., Roanoke, Va.; D. J. Cartwright, Asst. Elec. Engr., Lehigh Valley R. R., So. Bethlehem, Pa.; E. W. Jansen, Elec. Engr., Illinois Central R. R., Chicago, Ill.; H. C. Meloy, Elec. Engr., N. Y. C. R. R., Cleveland, Ohio; J. R. Sloane, Engr. Elec. Car Lighting, Penna. R. R., Altoona, Pa.; E. Wanamaker, Elect. Engr., C. R. I. & P. Ry., Chicago, Ill.

14. Nominations: F. W. Brazier (Chairman), S. R. S., N. Y. C. R. R., New York City; D. F. Crawford, G. S. M. P., Penna. Lines, Pittsburgh, Pa.; D. R. MacBain, S. M. P., N. Y. C. R. R., Cleveland, Ohio; C. E. Fuller, S. M. P., Union Pac. R. R., Omaha, Neb.; M. K. Barnum, S. M. P., B. & O. R. R., Baltimore, Md.

15. Arrangements: C. E. Chambers, S. M. P., C. R. R. of N. J., Jersey City, N. J.

16. Tank Cas: A. W. Gibbs (Chairman), C. M. E., Penna. R. R., Philadelphia, Pa.; Thos. Beaghen, Jr., M. C. B., Union Tank Line, New York City; C. E. Chambers, S. M. P., C. R. R. of N. J., Jersey City, N. J.; Wm. Schlafge, G. M. S., Erie R. R., New York City; S. Lynn, M. C. B., P. & L. E. R. R., McKee's Rocks, Pa.; John Purcell, Asst. to V.-P., A. T. & S. F. Ry., Chicago, Ill.; O. J. Parks, G. S., German-American Car Lines, Chicago, Ill.

17. Draft Gear. R. L. Kleine (Chairman), G. C. I., Penna. R. R., Altoona, Pa.; Prof. L. E. Endsley, University of Pittsburgh, Pittsburgh, Pa.; W. E. Dunham, Supr. M. P. & M., C. & N. W. Ry., Winona, Minn.; J. R. Onderdonk, Engr. Tests, B. & O. R. R., Baltimore, Md.; A. R. Kipp, M. E., Soo Line, Fond du Lac, Wis.; G. W. Rink, M. E., C. R. R. of N. J., Jersey City, N. J.; J. C. Fritts, M. C. B., D. L. & W. R. R., Scranton, Pa.; R. D. Smith, S. M. P., B. & A. R. R., Boston, Mass.; A. M. Darlow, S. M. P., B. & S. R. R., Galeton, Pa.; H. C. May, S. M. P., L. V. R. R., So. Bethlehem, Pa.

18. Welding Truck Side Frames, Bolsters and Arch Bars: W. O. Thompson (Chairman), S. R. S., N. Y. C. R. R., Buffalo, N. Y.; G. W. Rink, M. E., C. R. R. of N. J., Jersey City, N. J.; J. T.

Wallis, G. S. M. P., Penna. R. R., Altoona, Pa.; J. J. Hennessey, M. C. B., C. M. & St. P. Ry., W. Milwaukee, Wis.; A. M. McGill, A. S. M. P., L. V. R. R., So. Bethlehem, Pa.; R. W. Schulze, S. C. D., St. L. & S. F. R. R., Springfield, Mo.; Willard Kells, A. G. S. M. P., A. C. L. R. R., Wilmington, N. C.; J. R. Gould, S. M. P., C. & O. Ry., Richmond, Va.; E. H. Sweeley, G. F. L. R., Long Island R. R., Richmond Hill, N. Y.; C. F. Giles, S. M., L. & N. R. R., Louisville, Ky.

19. Standard Blocking for Cradles of Car Dumping Machines: Jas. McMullen (Chairman), M. S., Erie R. R., Meadville, Pa.; J. W. Senger, M. C. B., N. Y. C. R. R., Collinwood, Ohio; J. J. Tatum, S. F. C., B. & O. R. R., Baltimore, Md.; F. T. Hyndman, S. M. P. & C., W. & L. E. R. R., Brewster, Ohio; T. W. Demarest, S. M. P., Penna. Lines, Ft. Wayne, Ind.; J. E. Davis, M. M., Hocking Valley Ry., Columbus, Ohio; G. M. Gray, S. M. P., B. & L. E. R. R., Greenville, Pa.; J. A. Pilcher, M. E., N. & W. Ry., Roanoke, Va.

#### The Traveling Engineers' Association.

The annual convention of the Traveling Engineers' Association, which was postponed on September 5, will be held at the Hotel Sherman, Chicago, Ill., commencing on Tuesday, October 24, and continuing four days. As announced in our August issue, the association is in a flourishing condition, the postponement of the annual meeting being deemed advisable on account of the threatened strike, which has been averted.

The following are the list of subjects to be presented by special committees, and discussed by the members:

"What effect does the mechanical placing of fuel in fire-boxes and lubricating of locomotives have on the cost of operation."

"The advantages of the use of superheaters, brick arches and other modern appliances on large engines, especially those of the mallet type."

"Difficulties accompanying the prevention of dense black smoke and its relation to cost of fuel and locomotive repairs."

"Recommended practice in the make-up and handling of modern freight trains, on both level and steep grades, to avoid damage to draft rigging."

"Assignment of power from the standpoints of efficient service and economy in fuel and maintenance."

The membership is over one thousand, and a large attendance is expected. Mr. J. R. Scott, of the St. Louis & San Francisco, is president, and Mr. W. O. Thompson, of the New York Central is secretary.

Every indication points to an unusually large attendance, and the proceedings will be fully reported in our pages at as early a date as possible.





## A Clear Track

ahead, Railway men, when you protect your metal work with

# DIXON'S Silica Graphite PAINT

It has a world-wide reputation of over fifty years. Made in **FIRST QUALITY** only. Made for those who want **QUALITY, LONGER SERVICE** and **LOWEST COST** per year of service.

Because of the peculiar oily nature and flake formation of the pigment, Dixon's Paint has no equal in keeping moisture and gases away from the metal. Therefore metal properly painted with it resists corrosion longer than that painted with any other paint. That is the reason why leading railroads throughout the entire world use it as standard.

Write for booklet 69-B and long service records.

Made in **JERSEY CITY, N. J.**, by the

**Joseph Dixon Crucible  
Company**

ESTABLISHED 1827

B-132

### Railroad Equipment Notes.

The Grand Trunk is reported in the market for 20,000 tons of rails.

The Atlantic Coast Line is in the market for 50 to 100 double-deck stock cars.

The New York Central is reported contemplating the purchase of 230 locomotives.

The Chicago, Milwaukee & St. Paul is building 1,000 freight cars in its own shops.

The Bethlehem Steel Company has ordered 30 hopper cars from the Pressed Steel Car Company.

The Southern Railway has ordered 20,000 tons of Bessemer rails for delivery in the first half of 1917.

The Havana Central has placed orders with the United States Steel Corporation for 10,000 tons of rails.

The British Government has ordered 45 narrow gauge locomotives from the Baldwin Locomotive Works.

The Michigan Central has ordered the Western Steel Car & Foundry Company to repair 500 freight cars.

The New York, New Haven & Hartford is reported in the market for 28 Santa Fe (2-10-2) type locomotives.

The Great Northern is in the market for 125 all steel passenger cars to replace Oriental limited equipment.

The Central of New Jersey has placed an order with the American Car & Foundry Company to repair 250 box cars.

The New York, Chicago & St. Louis has has ordered 10 Mikado type locomotives from the Lima Locomotive Corporation.

The Pittsburgh & Lake Erie has ordered 10 Mikado (2-8-2) type locomotives from the American Locomotive Company.

The Pittsburgh & Lake Erie has ordered 10 coaches from the Pressed Steel Car Company and is still in the market for one dining car.

The order for steel for locomotive shops at East Deerfield, Mass., for the Boston & Maine, 325 tons, is reported placed with the American Bridge Company.

The Atchison, Topeka & Santa Fe proposes to start construction early in 1917 on new freight terminals and yards at Hutchinson, Kan., to cost \$1,000,000.

The Russian Government has ordered 4,000 steel gondola cars of 40-ton capacity from the Bettendorf Company, and is inquiring for additional rolling stock.

The Boston & Maine has ordered 2 additional 130-ton Baldwin-Westinghouse electric locomotives for the Hoosac tunnel, similar to the five now operating.

The Denver & Rio Grande has ordered three steel turntables to weigh 202 tons from the American Bridge Company. They will be installed at Denver, Colo., and at Pueblo.

The New York, New Haven & Hartford will construct 11 new street girder highway bridges of single 75-foot spans, to cost altogether about \$829,000. Bids for work have not yet been asked.

The Boston & Maine has ordered 325 tons of steel from the American Bridge Company for shops at East Deerfield, Mass. It has also ordered 150 tons of bridge work from the Phoenix Bridge Works.

The New York, New Haven & Hartford has authorized the Osgood-Bradley Car Company to proceed with the construction of 60 coaches. These are part of a large contract placed with this manufacturer some time ago.

The New York Central has ordered 1,000 box cars from the American Car & Foundry Company. These are in addition to 1,000 box cars recently ordered from the same builder, 1,000 box cars from Haskell & Barker Car Co. and 1,000 gondola cars from Standard Steel Car Company.

The Piedmont & Northern will construct an eight-span, deck-plate girder bridge, 700 feet long and 55 feet above normal water, across the Catawba river at Mt. Holly, N. C., to cost about \$125,000; replacing structure destroyed by flood. Virginia Bridge & Iron Company has the contract for steel work and Thos. Sheahan, of Hagerstown, Md., for masonry.

The Chicago Great Western has placed orders for 79 crossing bells of the locomotive type for installation on the entire system as follows: Eastern division, 25 bells; Northern division, 25 bells; Southern division, 19 bells, and Western division, 10 bells. The installation of new automatic block signals on the Southern division between Marshalltown and East Des Moines, Iowa, is proceeding rapidly. Practically all material for this work has been delivered and signals will be ready to place in service within another month.

### Increasing Use of Pipe.

The history of the widely ramifying uses of pipe is remarkable, and coincident with the extended use of tubular products has been the change in material. Fifty years ago all of the screw joint pipe was made from wrought iron, but the invention of the Bessemer and the open-hearth processes of making steel have caused a decided change in the material, and recently a statistical bulletin was issued by the American Iron and Steel Institute showing that the use of wrought-iron has decreased from 452,797 tons in 1905 to 262,198 in 1915, and at the same time the percentage of total has decreased from 31.5 in 1905 to 11.4 in 1915 and the percentage of the use of steel has correspondingly increased. In ten years the production of steel skelp has increased from 1,435,995 tons to 2,299,464, being an increase of 88.6 per cent. The National Tube Company has recently announced plans for building a new plant at Gary, Indiana, having a capacity of 500,000 tons per year, and it may be confidently assumed that the uses of pipe have by no means reached their limit.

### Tunnel Under the English Channel.

For many years a tunnel under the English Channel, connecting Great Britain and France, has been talked of. Since the war began this much-discussed project has been revived in a serious form and it is generally accepted, in England at least, as almost certain that the often-contemplated work will be undertaken. When it is, it will probably have the backing of both the British and French governments.

The advances in modern engineering have been such during the past few years as to render it possible to overcome the obstacles which have helped deter actual operations in this regard, and furthermore, the alliance of the two nations has been so cemented as to remove any opposition that formerly arose on the score of military precaution.

The distance across, from Dover to Calais, is approximately 21 miles. If constructed, it will be the longest subaqueous tunnel in the world and will call for the highest type of engineering ability in its design and construction.

The actual carrying out of such an enterprise may be delayed, but the feeling is growing stronger every day that it ought to be gone on with, and doubtless before many years have passed we shall see the work commenced. It is presumptuous for anyone to say what can or cannot be done. There seem to be no obstacles from an engineering point of view and in any event it is doubtful whether it is ever wise to place any limit on the ingenuity and ability of the engineer.

The cost will be enormous, but if the British empire and the French republic agree, the work will be accomplished.

### Continuation of Car Shortage.

The shortage of cars has become so serious that determined efforts are being made not only by the railroad companies, but by the Interstate Commerce Commission, urging the absolute necessity of a more rapid unloading of freight. Of course, it is generally understood that much of the trouble has arisen from the fact that many loaded cars are tied up at the seaboard on account of the insufficient supply of shipping. The movement of crops and coal is consequently delayed and the situation is baffling the minds of the shrewdest railway men, who all admit the situation is without a parallel.

### Electrical Exposition.

The New York Electrical Exposition will be held in Grand Central Palace, New York City, from October 11 to 21. The importance of this exhibit, from an educational standpoint, cannot be overestimated, for the general public is surprisingly uninformed on many of the features that will be on exhibition. Among others, the electric welding of iron and steel will be one of the feature exhibits, and the public will have an opportunity of seeing all grades of welding accomplished in iron and steel, including structural pieces, plates and castings. The United States Government is co-operating in the Electrical Exposition through the War, Navy and Commerce Departments, all of which will have comprehensive exhibits.

### Demand for Welders.

No better proof of the rapid application of autogenous welding, wherever practicable, could be found than in the growing demand for experienced welders. There is every likelihood of this demand increasing, and as might be expected schools for teaching welding are springing up all over the country, and it would be proper and becoming that some Federal or State regulations should be adopted in regard to these institutions. Welding, by whatever process, cannot be learned in a day, and the publishers of misleading advertisements should be guarded against.

### Railways in India.

Large additions have been made to the rolling stock in use upon the Indian systems, the number of locomotives being especially augmented. The reports in regard to the application of the superheater appliance has been such that several Indian railways have decided to fit all their main line engines with superheaters. Trials have also been made with oil as fuel, but the results are not yet published.

# GOLD Car Heating & Lighting Company

Manufacturers of

**ELECTRIC,  
STEAM AND  
HOT WATER  
HEATING  
APPARATUS  
FOR RAILWAY CARS  
VENTILATORS  
FOR PASSENGER  
AND REFRIGER-  
ATOR CARS  
ACETYLENE SYSTEM  
OF CAR LIGHTING**

Send for circular of our combination **PRESSURE AND VAPOR SYSTEM OF CAR HEATING**, which system automatically maintains about the same temperature in the car regardless of the outside weather conditions.

Main Office, Whitehall Building  
17 BATTERY PLACE  
NEW YORK

# Hydraulic

**Riveters Fixed and Portable  
Punches, Shears,  
Presses, Lifts, Cranes  
and Accumulators.**

**Matthews' Fire Hydrants,  
Eddy Valves  
Valve Indicator Posts.**

**The Camden High-Pressure Valves.**

**Cast Iron Pipe**

**R. D. Wood & Company**

**Engineers, Iron  
Founders, Machinists.**

**100 Chestnut St., Philadelphia, Pa.**

**Nichols Transfer Tables  
Turntable Tractors**  
GEO. P. NICHOLS & BRO.  
1090 Old Colony Bldg. CHICAGO

**For Testing and Washing  
Locomotive Boilers**  
USE THE

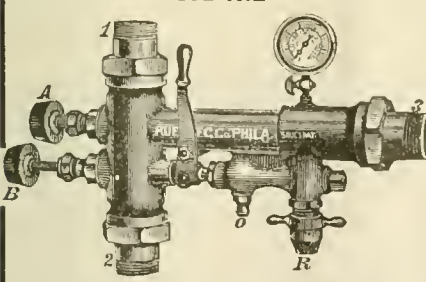

**Rue Boiler Washer  
and Tester**  
SEND FOR CATALOGUE  
Rue Manufacturing Co.  
228 Cherry Street Philadelphia, Pa.  
Manufacturers of Injectors, Ejectors,  
Boiler Washers and Testers, Boiler Checks,  
Check Valves.



**ASHTON  
POP VALVES AND GAGES**  
The Quality Goods That Last  
The Ashton Valve Co.  
271 Franklin Street, Boston, Mass.  
No. 174 Market St., Chicago, Ill.

# Books, Bulletins, Catalogues, Etc.

**LOCOMOTIVE MANAGEMENT.** By Donald R. MacBain. Published by the Author, Cleveland, Ohio. Price, \$1.

In 1900 the author of the above named book published one bearing the same title which proved very popular among engineers, but owing to the changes in locomotives went out of date. To remedy that the author has re-written the book, bringing it up to date, and the new edition is now before us.

The new edition begins with Preliminary Lessons for Beginners which contains a mass of useful information relating principally to scientific facts relating to locomotive engineering. This part embraces 33 questions and answers besides 32 answers to leading questions.

Then comes a section of Examination for Promotion which contains 131 questions and answers forming an exhaustive treatise in itself that will enable any fireman to display thorough knowledge of the working of the engine. Compound Locomotives comes next with 30 questions and answers, all of them worth committing to memory.

Information relating to brakes covers twenty pages of the book and leaves out nothing that an efficient engineer ought to know. Valve gear occupies a prominent part of the book and is well illustrated by excellent wood cuts. The portion on valve gear would be worth more than the book costs were no other good things in it. Besides the subject there are a variety of miscellaneous articles that contain highly valuable information. To any man ambitious to learn all about the locomotive and how to manage it, we say study every page of the book, not only read but study every line, and the time will be better spent than it can be spent in any other way.

**PRACTICAL TRACK MAINTENANCE.** By Kenneth L. Van Auken. Published by the Railway Educational Press, Chicago, Ill. 310 pages; 37 illustrations; ornamental cloth. Price \$1.60.

The author of this book has had many years' experience in railroad track work, and not only knows the subject that he treats of thoroughly, but has acquired a clear and direct mastery of English. Much of his work has appeared in the railway engineering press preliminary to being revised and prepared for the more enduring form which a book implies. The work is divided into fifteen chapters, each dealing with some separate subject and each complete in itself. Several of the chapters are devoted to varying season of the year, the kind of work to be done, and the most approved method of doing it, with complete details in regard to the use and care of tools. Of real value also is the chapter on how to handle

track laborers. The various nationalities engaged in such work are all treated of in an intensely human way and shows the author to be a close student of his fellow man. To all who are in any way engaged in track maintenance this work will be found to be of real value, and among these it is sure of a popular reception particularly, as well as among the best class of railway men generally.

**Air Brake Association Proceedings.**

The published proceedings of the twenty-third Air Brake Association convention is just off the press. The meeting was held at Atlanta, Ga., early in May. After the usual pleasant formalities of opening the convention, with its hearty welcome from the mayor, the association got down to business. The reports of the secretary and the treasurer showed a very satisfactory membership and a good working balance in the bank.

The first paper presented was on "slack action in long passenger trains: its relation to triple valves of different types and consequent results in handling passenger trains." Messrs. J. H. Burke and J. Holtzfield are the gentlemen who signed this paper, which is very comprehensive in its scope. It deals with the weight of the vehicle, the length of trains, foundation brake gear and the air brake mechanism itself. There was an interesting and animated discussion, in which a great many speakers took part and the subject was pretty well thrashed out. The second paper, by Mr. C. D. Drennan, was on the subject of the "best methods of educating apprentices to give the railroads efficient air brake mechanics." This important subject was very carefully handled and was backed by a considerable array of statistics as to the number of men employed and their various duties, which are comprised under the three headings, "keep down failures; keep engines and cars moving; and add much to the life of air brake equipment." A very interesting discussion followed this paper. The third paper, prepared by Mr. C. W. Joy, was on "the care of modern passenger brake equipment. The factors contributed to the minimum cost of maintenance with maximum efficiency." Mr. Joy began by taking up the subject of inspection, followed by that of yard testing, maintenance, valvular mechanism, piping, brake cylinders and mechanical transmission. The report was illustrated with drawings showing the clasp brake and the method of measuring wheel wear. A very full discussion took place on this paper. The paper by Mr. Fred Von Bergen on "the proper piping of locomotives and cars, specifications and requirements for pipe and air brake work." The paper, although a short one, elicited a discussion which was carried

over to the following day. Mr. M. S. Belk read a paper on "excess pressure," which also was short, but which was very fully discussed by the association. "Hand brakes for heavy passenger cars" was the subject chosen by Mr. John P. Kelley and was listened to with much interest. Mr. Mark Purcell took up the subject of "the need of efficient cleaning and repairing of freight brakes." He presented a table showing the number of triple valves removed for all causes, and the numbers of valves removed for specific failures. The paper brought forth a very full and animated discussion. "Recommended Practice," by Mr. S. G. Down, naturally produced an extended discussion as each of the various points brought out were taken up by the association. "The accumulation of moisture and its elimination from trains on yard testing plants," by Mr. Mark Purcell, was an instructive paper which led to an animated discussion on the subject. The routine committees presented their reports and the meeting was brought to a close on Friday the fifth of May. The officers for 1916 and 1917 are: President, T. W. Dow, Erie Railroad; first vice-president, C. H. Weaver, L. S. & M. S.; second vice-president, C. W. Martin, Pennsylvania R. R.; third vice-president, F. J. Barry, N. Y., O. & W.; secretary, F. M. Nellis, Westinghouse Air Brake Company; treasurer, Otto Best, Nathan Mfg. Co.

#### Mikado Type Locomotives.

The Baldwin Locomotive Works has issued Record No. 83, describing and illustrating 27 Mikado type locomotives, ranging in weight, including tender, from the type used by the McCloud River Railroad Company, of 260,000 lbs., to the heavier class used on the Atchison, Topeka & Santa Fe, of 506,000 lbs. As is well known, large numbers of these locomotives have been built in recent years, especially for heavy freight, and also for special passenger service in mountainous districts. The chief merit of this type of locomotive is on account of its great boiler power. With a long barrel and a deep, wide firebox, its steaming qualities are of the best. Those recently constructed are nearly all equipped with superheaters. The brick arch also improves its efficiency, especially in locomotives using high volatile coal. Labor-saving devices are also shown in the record to be coming rapidly into popular favor. The use of the mechanical stoker gives promise to become general in the Mikado type of locomotive, and by its use the largest kind of locomotives can be worked at full capacity, under conditions where it would be impossible to maintain steam pressure with hand firing.

All interested should have a copy of this fine illustrated Bulletin, which may be had on application to the Baldwin Locomotive Works

#### Graphite.

The current issue of *Graphite*, published by the Joseph Dixon Crucible Company, Jersey City, contains among other interesting items an illustrated article descriptive of the bridge over the Ohio river between East Liverpool, Ohio, and Newell, W. Va. Over ten years ago this bridge was painted with Dixon's Silica-Graphite paint. This is only one of many records proving the long service of this protective paint. With such records it is not surprising that the demand for this particular kind of paint continues to grow. Like Ajax defying the thunder, it defies the elements. Summer's heat and winter's snow are alike to it. It is the favorite with railroads, factories, government and other experts who must have the best economy paint. Fifty years' experience has given the company many advantages in the tests that come with time. Copies of the company's publication may be had on application to the main office at Jersey City, N. J.

#### Making Davis Wheels.

A profusely illustrated pamphlet issued by the American Steel Foundries, McCormick Building, Chicago, furnishes the complete details of the manufacture of the Davis steel wheel in a brief pictorial way from the preparation of the mold to the final test for hardness. It is convincingly shown that every possible precaution is taken to produce a safe, serviceable wheel. Completed, the wheel has a hard, tough manganese steel tread and flange, combined with a ductile steel plate and hub. It resists shock and abrasion and renders full mileage without the trouble and expense of turning. Broken flanges and other common wheel troubles are practically eliminated. There is also a considerable lessening in weight with a corresponding saving in cost. Copies of the interesting pamphlet may be had on application to the company's office at Chicago.

#### Preparation of Coal.

The Engineering Experiment Station of the University of Illinois has made an extensive study of the methods employed in the preparation of bituminous coal at Illinois mines, and the data and information which have required several years to compile have been tabulated and analyzed by Prof. E. A. Holbrook, and are now published as Bulletin No. 88 of the experiment station. Present preparation practice, standard types of plants, impurities, and sizing of coal are all fully treated, and a record is presented of the year's production of the different sizes of coal in Illinois over a period of thirty-five years. Copies of the Bulletin may be had on application to W. F. M. Goss, Director, Urbana, Ill.

**STEEL STAMPS**  
INSPECTORS HAMMERS  
Hand Cut STEEL LETTERS & FIGURES  
LATHE TOOLS, TIME CHECKS,  
Noble & Westbrook Mfg. Co.  
9 ASYLUM ST. HARTFORD, CONN.

### Locomotive Engine Running and Management

By ANGUS SINCLAIR

This popular book has been a RELIABLE REFERENCE and comfortable unfailing POCKET EDITION.

PRICE, \$2.00

ANGUS SINCLAIR CO.

114 Liberty St.,

New York

### Locomotive Electric Headlights of all descriptions

**THE RAYLE-NATIONAL COMPANY**

TURBO GENERATOR SETS

900 SOUTH MICHIGAN AVENUE

CHICAGO, ILL.

### THE ARMSTRONG IMPROVED PACKER RATCHET DRILLS

Are ALL STEEL

and

Hardened All Over

Will outwear two of the soft kind.

We make all kinds—all sizes.

Do you want a catalog?

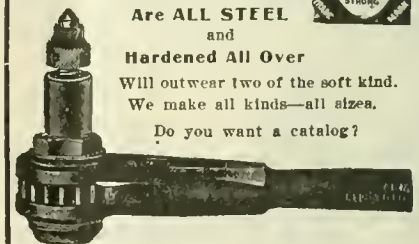

ARMSTRONG BROS. TOOL CO.

"The Tool Holder People."

112 N. FRANCISCO AVE., CHICAGO, ILL.

ENAMELED IRON FLUSH OR DRY CLOSETS

**DUNER CAR CLOSETS**

DUNER CO.

116 S. CLINTON ST., CHICAGO

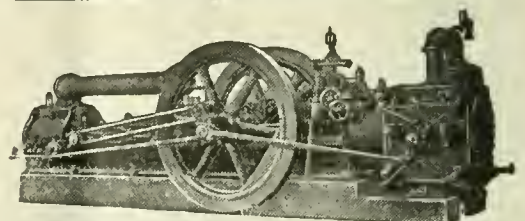

### The Norwalk Iron Works Co.

SOUTH NORWALK, CONN.

Makers of Air and Gas Compressors

For All Purposes

Send for Catalog

# Railway AND Locomotive Engineering

A Practical Journal of Motive Power, Rolling Stock and Appliances

Vol. XXIX.

114 Liberty Street, New York, November, 1916.

No. 11

## Locomotive Cranes for Railway Use

Various Kinds of Work Performed—Crane Can Move Itself and Spot Cars—  
Larger and More Powerful Machines Now Being Used

The use of locomotive cranes for railway operating as well as construction work has been and is a phase of the transportation industry which has made very remarkable progress in recent years. In former days the "steam ditcher" was thought to be a necessity for construction

be said of a certainty where heavy and otherwise slow continuous work has to be done.

One of the most interesting features about locomotive crane work is the introduction of electricity into the problem. These cranes can be equipped with a small

confined to the radius of the crane arm. The whole machine is capable of not only propelling itself along the track, but is able to haul several cars up a grade. On level 18 to 20 loaded 50-ton cars is not an excessive performance. Thus a series of rail cars can be unloaded by the magnet

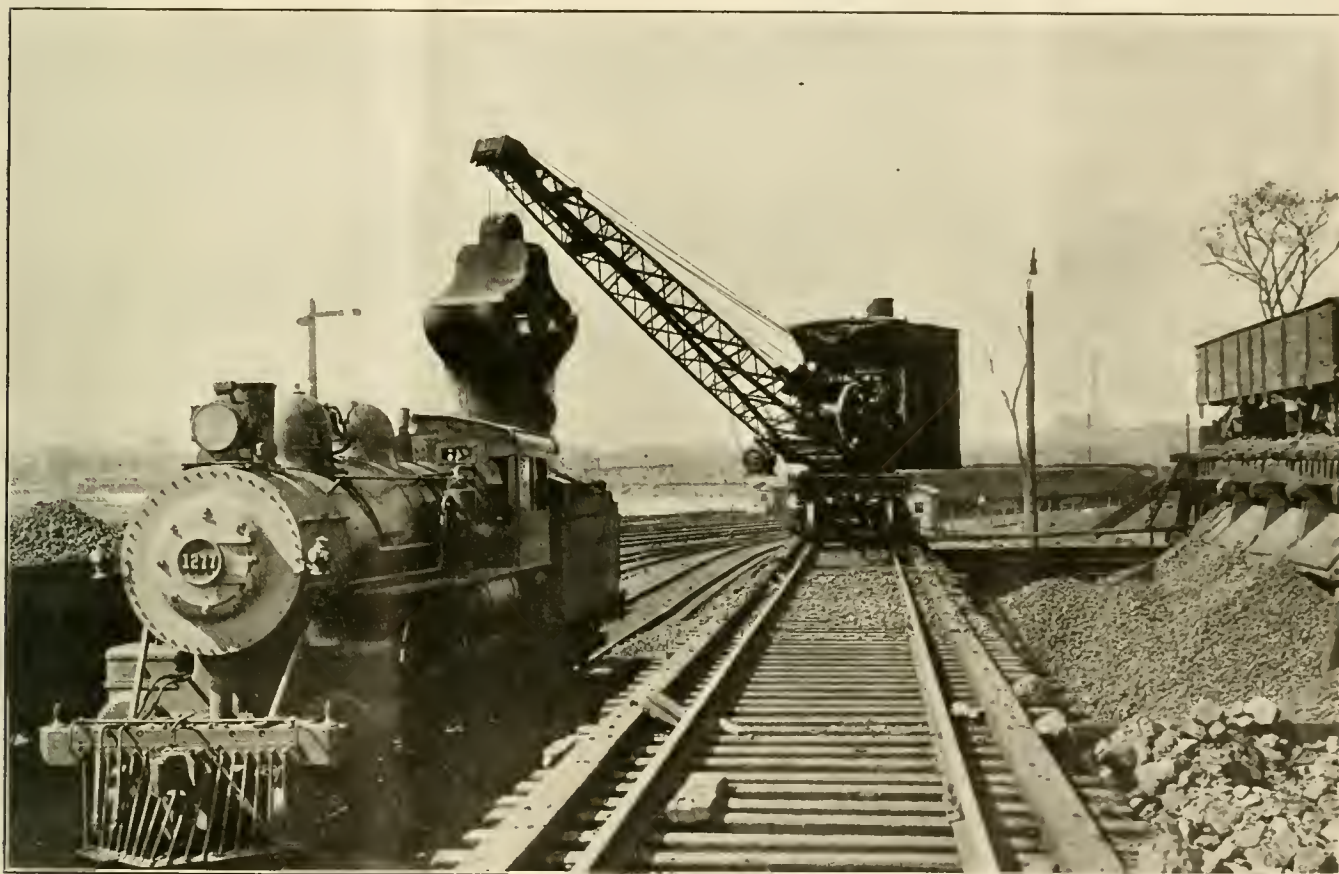

LOCOMOTIVE BEING SUPPLIED WITH COAL BY CRANE, USING PICK-UP OR GRAB BUCKET.

work, but today railways handle coal, ore, stone, cinders, gravel, sand, etc. To do this work the modern locomotive crane is equipped with a grab bucket. The orange-peel bucket takes care of heavy excavating work. A drag-line bucket does drag-line work with great facility. In fact, many forms of hand labor are now replaced by the crane and this may

dynamo run by the steam generated by the crane boiler, and when this is done the contact between the load and the lifting chain is made by a powerful electro-magnet. The big steel rails, scrap, bars, sheets and castings can be lifted from a car and swung round by the crane so as to be placed where desired. The area of distribution of such loads is not

attachment, but when the space on each side of the track is filled the crane and the cars containing the rails can be moved ahead and distribution again resumed.

The modern locomotive crane can be fitted with a set of blocks and a lumber grab which handle ties, logs, large castings, structural material, bars, tubs and

buckets, and many other similar operations are easily and expeditiously performed. A locomotive in the ordinary sense of the word is a special machine for hauling cars; the locomotive crane has specialized in a different direction and, when compared, locomotive and crane are somewhat like a heavy Clydesdale horse and an elephant. The elephant of the railroad does not haul as many cars as the iron horse, nor does it travel as fast, though on occasion it can switch and spot cars. Its crane and attachments are like the elephant's trunk by which, when these animals are trained, as they are in India, the trunk performs all the functions of a pair of strong and intelligently directed hands.

When cranes were first introduced on

The Lehigh Valley Railroad has used locomotive cranes extensively for track renewals and in clearing away the wreckage on Black Tom Island after the explosion of stored shells and ammunition these cranes did good work in disentangling the twisted iron and steel work and lifting the shattered and useless debris to cars so that it could be moved out of the way.

A steam or drop hammer can be worked on the crane for driving the different kinds of piling. Steam for the steam hammer is supplied from the boiler on the crane. Steel leads are furnished which guide the hammer and make it possible to drive batter piles. A double drum is used with this work. By the use of outriggers, the crane's capacities can be increased 10 to 40 per cent. The

Sanitation Rules" containing precautionary practice that has been found necessary to enforce in conducting the operation of its trains, tracks and shops. In two years the reduction in fatal accidents on the road has been reduced 56 per cent. The dissemination of the booklet among all classes of employees is expected to decrease accidents to the minimum. Prefacing the booklet is a letter to employees from Mr. J. M. Davis, operating vice-president, insisting that "Safety must be the first consideration of every department of the service and that compliance with the rules and the co-operation of each employee is imperative." Other railroads should follow the good example.

#### Speed Checks at Grade Crossings.

Experiments are being conducted on a California highway with grade checks or bumps constructed in the pavement to reduce the speed of vehicles at grade crossings. These are placed for a short distance on each side of the tracks, so arranged as to demand careful driving and reduce speeding. These bumpers are in the form of rounded ridges, nine to twelve inches high and are from four to six feet wide at the base, and two feet at the crown. Where there is a double roadway only the right hand roadway is thus marked. Accidents have been materially reduced since the installation of the bumpers.

#### Railroad Building at Night.

Railroad construction in Africa at night is made possible by the use of a freight car as a lighting plant. Projecting from a tower at one end is a light arm that extends out over the track. At the extreme end of this arm two searchlights are placed, while other lamps are located at intervals along the arm. By means of this arrangement plenty of light can be shed upon the portion of the track that the arm overhangs, while beams of the searchlight can be cast ahead where the work of preparing the roadbed is under way. The lighting plant permits of work in the cool hours while the torrid sun is below the horizon.

#### Idle Cars Aggravate the Shortage.

Careful enquiries show that much of the cause of car shortage is owing to the delays in unloading. The charges for demurrage are so light that it is very often cheaper to allow the car to stand for several days rather than hire a few extra men to unload the freight promptly. Measures are suggested to meet this flagrant abuse as appeals seem to have little effect on those using the cars. Loading to full visible capacity is also being urged, and a more general interchange of cars. A solution of the difficulty is much needed.

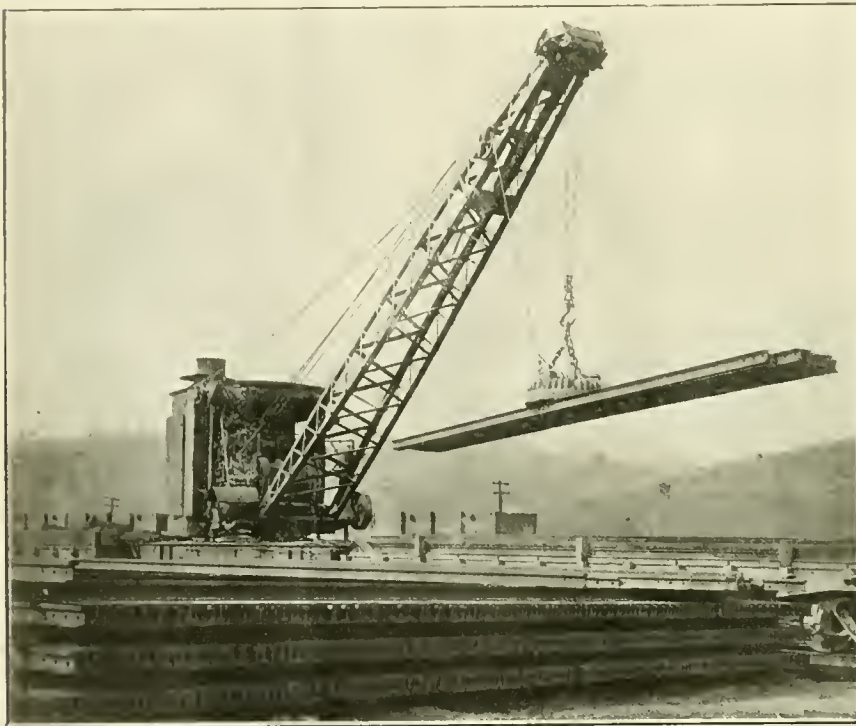

LOCOMOTIVE CRANE WITH MAGNETIC LIFTER, HANDLING STEEL RAILS.

railways the lighter forms had the preference, while at the present time the heavier cranes are considered to be more advantageous for their many uses and practically more economical in the long run. Thus 30 to 60-ton cranes are replacing the 15 and 25-ton cranes of a few years ago.

The danger of tipping over during a heavy lift has been provided for by the construction of a heavy, short and compact "car" frame upon which crane, boiler, cab and mechanism pivots. The "car" is made short so that the spread of the trucks is reduced to a minimum, and provision is made to anchor the "car" to the rails in a very substantial manner. The cranes can stand a 20 to 50 per cent. overload before there is any signs of tipping.

outriggers consist of a heavy I-beam on each side of the crane, which can be pulled out and blocked under the end. When not in use the beams are pushed under the car body.

There are several cranes of the locomotive type manufactured in this country and the satisfaction and economies which may be had from the use of them by railway companies puts them in the class of most desirable, not to say necessary, form of transportation equipment.

#### Safety Rules on the Baltimore and Ohio.

The Baltimore and Ohio keeps up the good work in the matter of "Safety First," the most recent item being the distribution of a booklet on "Safety and

# Jacking the Quebec Bridge

## The Lifting Jacks—Their Number and Position—Failure of Bridge Not Due to Jacking Mechanism—Dimensions of Jacks, Pumps Etc.

The process of raising the centre or connecting span of the Quebec bridge, which terminated so unfortunately in the entire loss of the centre span, was an engineering enterprise of no small magnitude. The hydraulic jacks used at the bridge were eight in number, having been supplied by the Watson-Stillman Company of New York. This firm is well known as the makers of all sorts of railroad jacks, hydraulic presses and other similar appliances used in railway repair work, and the Canadian authorities were dealing with a competent and reliable firm when they selected the Watson-Stillman equipment for the construction of the eight 1,000 tons capacity jacks which were to have made the connecting span part of the level floor of the bridge.

The loss of the centre span is believed

to have been caused by the failure of a steel casting attached to the span itself and by which the weight was carried on the lifting "chains" or girders which came down from the jacks above. Regrettable as was the accident, the Watson-Stillman Company are in no way responsible and will come out after the official inquiry with reputation untarnished.

Two jacks were placed to each jacking girder, and one jacking girder was at each corner of the centre span. The normal jacking pressure was 4,000 lbs. to the square inch. The jacks themselves were made of nickel steel. The jack operating valves were double balanced spindle stop and release valves, one valve for each jack. Each pair of jacks, composing one jacking unit, was fitted with tell-tales to show the relative motion of each jack ram. Each jacking unit on one end of the bridge was operated by a bal-

ancing spindle stop valve, at center of the cantilever. A tell-tale showing the relative motion of each jacking unit was fitted in front of the central control valve. All the tell-tales multiplied the motion by two, so that  $\frac{1}{8}$  in. variation of a jack, or jacking unit, showed  $\frac{1}{4}$  in. variation on the tell-tale. Screw jacks of 12 ins. diameter were provided to follow up the motion of the hydraulic jack rams, and these screw jacks were counter-weighted so that one man could easily follow up each jack. All these details were carefully worked out, and nothing was left to chance. The work done by the jacks up to the moment of the failure of the lower

attaching casting was satisfactory in every way.

The details of the pumps used with these jacks are interesting as a special appliance for producing a specific result. Some of the facts are as follows: Total of four direct acting steam pumps, 18 ins. cylinder, 2-in. plungers, 16 ins. stroke, making approximately 70 single strokes a minute under load. The pumps were operated by compressed air at 110 lbs. per sq. in., instead of by steam, as air was available from the compressor plant used in erecting the bridge.

Flexibility between the jacking girders and the platforms on the cantilevers was secured by the use of copper piping connecting the jacks to the steel piping. This accommodated any swinging of the jacking girders, due to mis-alignment, wind pressure, etc., in hoisting the centre span from the barges. The approximate time required to make one complete 24-in. lift, and return, preparatory for another lift, was about 15 minutes.

Dimensions of the chains used in lifting the centre span were, 30 ins. wide, plates, 2 bars per chain, each bar composed of two  $\frac{1}{8}$ -in. thick, plates. Number of chains per jacking unit were two, total number of chains were eight, the holes in the chains were large enough to accommodate 12-in. diameter pins. The spacing of the holes in the chains were 6-ft. centres, the spacing of holes in the jacking girders were 2-ft. centres.

The chains were fitted at the lower ends with elongated slotted holes, approximately 4 ft. long, to permit attachment to centre span at a level up to 2 ft. above or below nominal tide conditions which were anticipated at the time of this connection. The greatest possible flexibility was provided for in operating the jacks from either one or both pumps on each cantilever. One jacking unit could be operated by one pump entirely independent of the other jacking unit, which might be operated by another pump. Different pressures could be maintained in each jacking unit should occasion require, or either pump could operate all jacks on the same end of the bridge, or both pumps could operate all jacks. This flexibility of arrangement, or rather of function, was accomplished by cross connection valves.

The whole scheme was well thought out and the parts were put together with great care. This same system will be used again when the new connecting span is ready for raising to place in the bridge, and probably the fall of 1917 will see the work well on to completion.

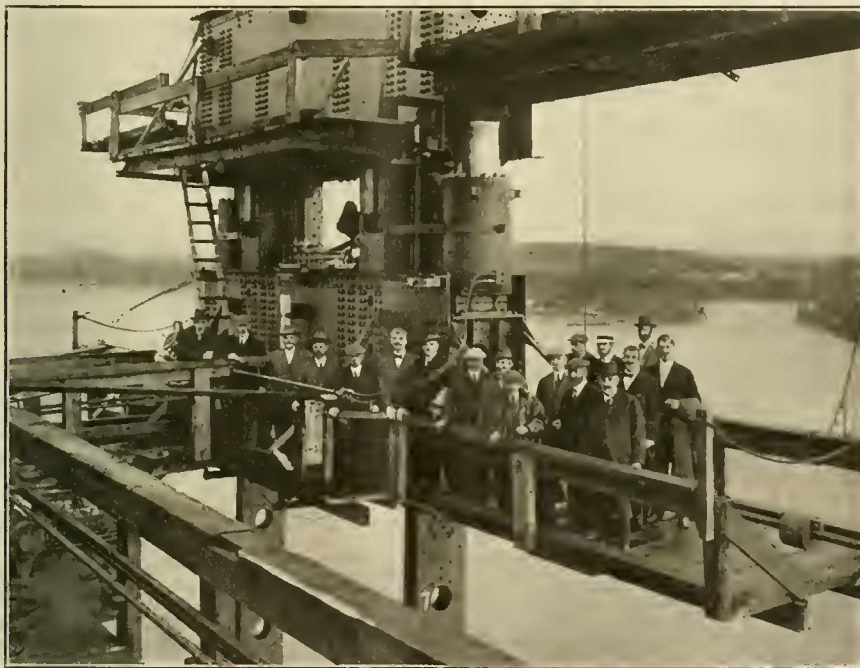

WATSON-STILLMAN LIFTING JACKS IN POSITION ON QUEBEC BRIDGE.

anced spindle stop valve, at center of the cantilever. A tell-tale showing the relative motion of each jacking unit was fitted in front of the central control valve. All the tell-tales multiplied the motion by two, so that  $\frac{1}{8}$  in. variation of a jack, or jacking unit, showed  $\frac{1}{4}$  in. variation on the tell-tale. Screw jacks of 12 ins. diameter were provided to follow up the motion of the hydraulic jack rams, and these screw jacks were counter-weighted so that one man could easily follow up each jack. All these details were carefully worked out, and nothing was left to chance. The work done by the jacks up to the moment of the failure of the lower

to have been caused by the failure of a steel casting attached to the span itself and by which the weight was carried on the lifting "chains" or girders which came down from the jacks above. Regrettable as was the accident, the Watson-Stillman Company are in no way responsible and will come out after the official inquiry with reputation untarnished.

# The Young Locomotive Valve Gear

Details of Improvements—Lighter than the Walschaerts Gear—Packing Rings Recessed in the Valve Chamber—Wider Parts and Exhaust Openings.

Since the introduction of the Young locomotive valve gear a year or two ago, several important improvements have been made in its construction tending to simplify the details of the mechanism and also add to its effectiveness in steam distribution and the lightening of the parts. In its perfected form it has been applied to a number of locomotives with the most gratifying results, and as we took the opportunity of calling the attention

more readily reached in case of repair or readjustment. There are other advantages also in the modern valve gears that need not now be dwelt upon. Suffice it to say that in the mere matter of weight of parts the Young valve gear can be very substantially constructed at least one-fourth lighter than that of the Walschaerts gear. This, of itself, is of importance as the locomotive continues to be constructed in heavier forms, and the lightening of any

Fig. 1 shows an assembled gear, motor driven and mounted on a testing trestle. The motion of the gear applied to the locomotive is derived entirely from the reciprocating movement of the pistons. Each piston causes the valve movement equal to its lap and lead on its own side, and travel of the valve in the opposite side. This diversity of movement is caused by the intervention of two rocking shafts. Valve travel, in addition to lap and lead, is produced through the oscillation of the link which causes the radius bar, when either above or below its central position, to oscillate the rocker shafts and is effective on the side of the locomotive opposite to the link that imparts the motion. As the front end of the radius bar acts on the lap and lead lever between its two extreme connections, unusually long travel is imparted to the valve without excessive angularity to the swing of the link.

It will be readily observed, therefore, that this feature alone accounts not only for a more rapid opening of the valve at the desired moment when the piston is about to reverse its movement, but also gives a much wider opening, and, relatively, a more rapid closing of the valve, with a more rapid and wider opening of the exhaust than is possible in the case of the Walschaerts valve gear. This rapidity and fullness of the desired openings approaches in its action more nearly that of the Corliss valve, which is only adaptable to stationary engines, than that of any other valve gear as now constructed. In the Walschaerts valve gearing seven inches of valve travel is the limit of

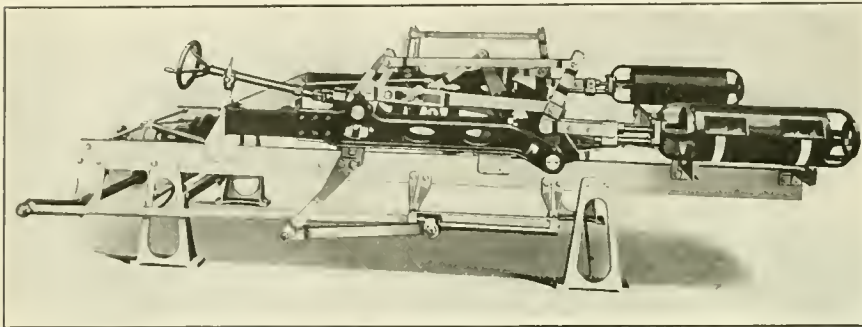

FIG. 1. MODEL OF ASSEMBLED GEAR MOTOR DRIVEN.

of the readers of RAILWAY AND LOCOMOTIVE ENGINEERING to the gearing when first introduced to the railroad world by the inventor, we have had numerous enquiries for particular information as to the progress that has been made, and the exact form in which it now appears

It should be observed at the outset that it does not follow that because some radical change has been made in some

part allows the power consumed in moving heavier parts to be applied to the purpose of moving the train.

This, however, is only one of the lesser advantages claimed for the Young valve gear. In the completed equipment consisting of valve, a valve gear, and a screw reverse gear there are distinct advantageous features that challenge attention, and from which it may be stated briefly that engines equipped with this valve gear are unusually reliable in starting, and it has been found that it is rarely necessary to slack even the heaviest trains in making the initial start. It is also claimed that the engines accelerate rapidly, attain and maintain very high speed and handle heavier trains particularly at higher speeds. Coal and water consumption is somewhat decreased. The principal reason for these results is on account of the wider port openings, both for inlet and outlet, which obtains a higher mean effective pressure under all conditions, and considerable reduction in negative pressures. Owing to the unusually free pre-release caused by the wider exhaust openings, together with the open valve construction, it is possible to reduce exhaust clearance, and in some cases valves are running in high speed passenger work with line and line exhaust. This is the logical reason for the economies claimed in coal and water consumption.

Coming to the details of construction,

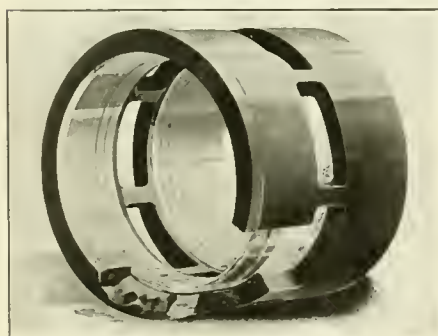

FIG. 2. VALVE CHAMBER.

mechanical detail that all preceding appliances for the same purpose should be looked upon as ineffective. The Stephenson valve gear did excellent service as long as the locomotives were what are now called small in size, and the eccentrics and their attachments could be conveniently reached. In the larger types of locomotives the Walschaerts and other valve gears are more serviceable because of being more easily applied and much

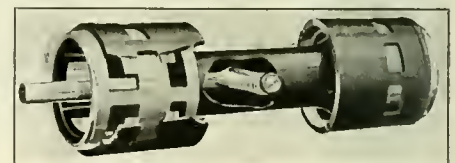

FIG. 3. VALVE.

capacity. The link swing is then 50 degrees, the link block lift 18 inches, the eccentric crank circle 20 to 22 inches, and unless the main rod is exceptionally long, the eccentric rod and radius bar angles are objectionable on account of the distortion of the symmetrical movement of the valve.

The Young valve gear produces an equitable valve movement under all conditions. The events are uniform and positive. With 42 degrees link swing, the maximum valve travel is eight and one-half inches. The sum of lap and lead is



one and five-eighths inches. The ratio between lap and lead may be proportioned to suit service conditions. Thus a gain of over 40 per cent. in width of steam port openings in early cut-offs is possible, and has been clearly shown by repeated indicator diagrams in authenticated trial tests. In early cut-offs the Young valve

between the valve and valve stem is for the purpose of assuring perfect alignment. It will thus be seen that the packing rings, instead of expanding to the irregular walls, are compression rings, and the valve is thereby converted into a movable plug, and its practicability is insured by the yielding contact between it and its en-

hand wheel are concentric instead of having separate axles connected by gear wheels, as is the practice on screw reversing gears generally. A cab indicator, properly graduated, shows correctly whether the gear is adjusted for forward or backward motion, and also what per cent. of cut-off is provided. This appliance is not affected by boiler expansion. It may be noted in this connection that as the rocking shafts and their attachments balance each other exactly, the movement of the reversing screw is very easy, changes in the cut-off requiring little or no physical effort even when the engine is acting under the highest steam pressure. This will be the more readily understood when it is observed that the radius bars with the reverse shaft on opposite sides of its axial line are caused to work adjacent to opposite ends of the links on opposite sides of the locomotive, so that when the right hand radius bar is at or near the top of the slot on the right hand link, the connection of the left hand radius bar is correspondingly at or near the bottom of the left hand link. One motion, therefore, as we have already stated, balances the other without the use of any counter-balance spring.

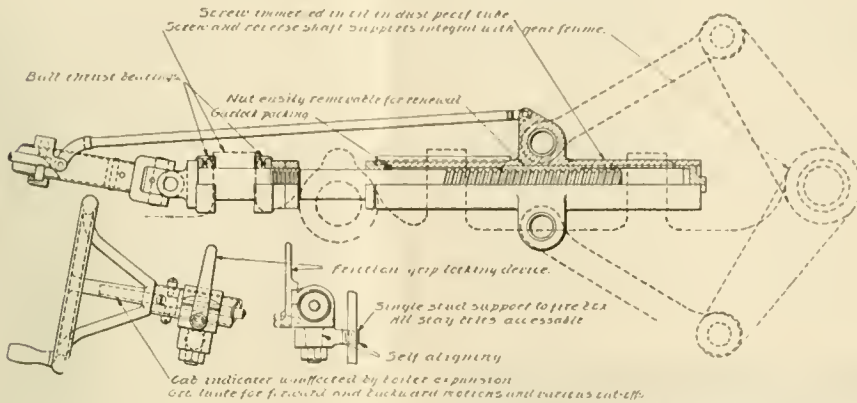

FIG. 4. SECTION VIEW OF THE REVERSE GEAR.

gear, with 11-inch valves, will supply as great a volume of steam to the cylinders as 16-inch valves are capable of doing with the Walschaerts gear.

Figs. 2 and 3 show views of the valve chamber and valve. It will be noted that in the Young valve the packing arrangement is reversed by recessing the rings into the walls of the valve chamber in sliding contact with the valve, thus relieving the moving member of 50 per cent. of its weight, the removal of the rings

circling rings; and, as a consequence, friction is nearly eliminated, and a prolonged service is secured, and considerable more of the power of the locomotive is available for draw bar pull.

Fig. 4 shows a section view of the reversing gear. The reverse shaft and reverse screw supports are integral with the gear frame and, as a consequence, positive control is maintained. The screw, which controls the reverse shaft, is immersed in oil in a dust-proof tube, im-

mersed in oil in a dust-proof tube, im-

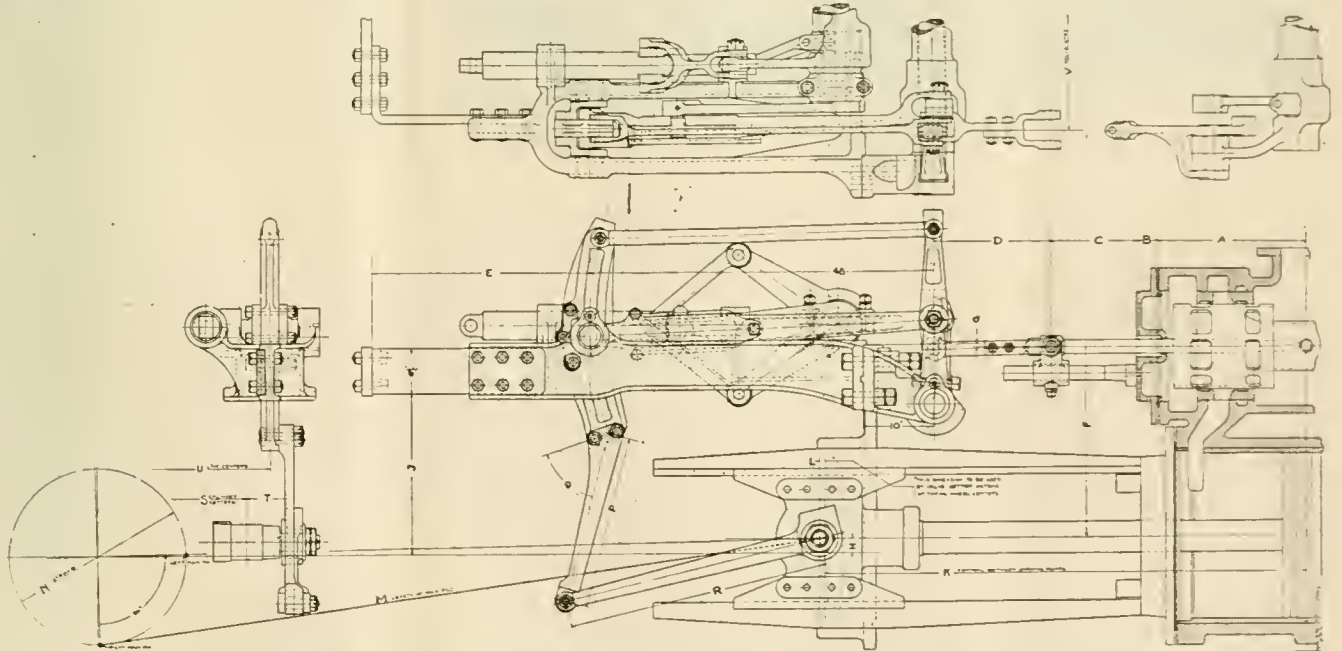

FIG. 5. ELEVATION AND PLAN VIEWS OF THE YOUNG LOCOMOTIVE VALVE GEAR.

from the valve precluding the necessity for bull rings and followers, the valve being simply a light cylinder cast in one piece of uniform thickness throughout, provided with suitable ports for admission and exhaust with its periphery ground to accurate finish. The knuckle attachment

ensuring easy and long service and perfect action, the ball thrust bearings securing perfect alignment and aiding in the easy manipulation. The operating rod is a pipe universally jointed to the screw and thence to the operating rod, and controlled by a hand wheel in the cab. The rod and

readily rebushed and replaced in the course of inevitable wear. In adjusting the gear, with crossheads connected to pistons and main rods disconnected, mark the guides to indicate the piston striking points. Show a mark on the guides central between striking points. Place the

centers of the crossheads back of this mark a distance equal to dimension "L." If the radius bar can then be moved from its lowest to its highest positions without movement to the rocker dimension, "R" is correct; if not, lengthen or shorten the union link to suit. With one crosshead in the above position, move the opposite crosshead to each end of its stroke and equalize the lead by means of the valve stem adjustment. Repeat the process for the opposite side. Then adjust the main rod lengths to cause equal piston clearance at both ends of the cylinders. Rollers under the drivers may then be used to check and record the cut-offs. If not alike on both sides of the locomotive, lengthen or shorten either the upper or lower reverse shaft link. The gearing will be found, when properly adjusted, to retain a correct movement of the valves

## The Carbide Flare Light

### Specially Adapted for Night Work on Railways Cannot Be Blown Out

This light is intended for wrecking, bridge repairs at night, work in tunnels where there is perpetual gloom, and repairs to signal systems which have to be carried on night and day, the carbic light "shines."

The principle of the light is as ingenious as it is useful. The "light" is made in five sizes and each light consists of but three parts. It operates on the principle of a diving bell, open at the bottom and closed at the top. In this "diving" bell, a cake holder, made of stout wire, is inserted which contains a "Carbic Cake." The opening of the valve leading to the

ble in water and the other has pronounced protecting qualities. When water touches the bottom of the cake, the soluble substance gives way to the action of the water, and permits a restricted entrance of that element, with the formation of a little gas. The slight amount of heat generated in forming this small quantity of gas bursts the protective covering of the carbic cake and leaves the pure carbide of calcium open to the action of the water and the formation of gas takes place, subject to the automatic generating feature already referred to. The coating of the particles of carbide is for the purpose of removing any danger of explosion, as the cake covering is non-absorbent and requires a slight or partial submergence, in order that gas will be given off. This also is a safety feature.

A knowledge of these chemical aspects on which the efficacy of the whole light depends, is not necessary to the operator, or rather to the men using the light. The user may not know the molecular peculiarities of carbide nor the effect of the coating of each particle, but what stands out clearly in his imagination is the service he gets, and the light is a piece of tangible evidence that he cannot gainsay. The light cannot be blown out, it does not fail, the tanks are made in convenient sizes, and are portable, the light is clear and strong and just what is needed for the many hard conditions found on railways. It is useful, and the whole matter is well worth looking into.

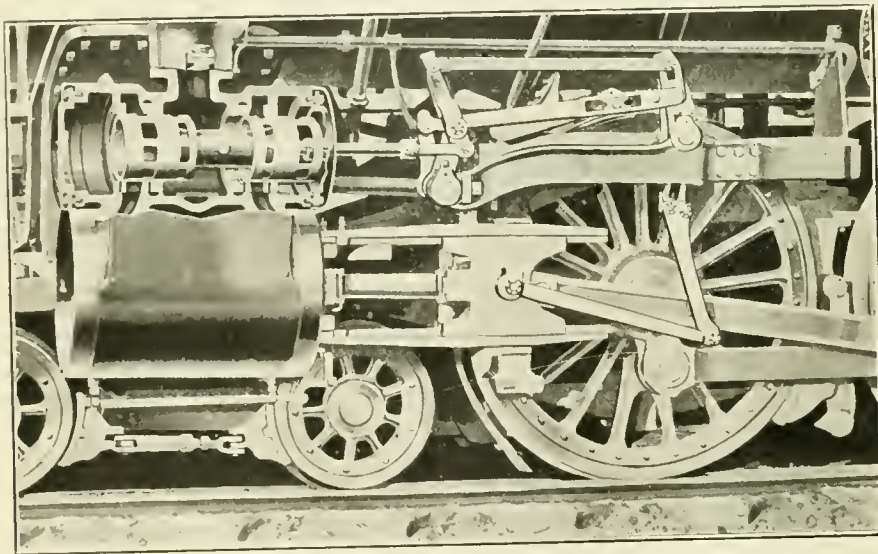

FIG. 6. VIEW OF VALVE GEAR APPLIED TO A LOCOMOTIVE WITH VALVE EXPOSED.

with a degree of continued certainty not surpassed by any other kind of valve gear applied to the modern locomotive.

Fig. 6 is a view of the valve gear as applied to a locomotive. The valve chamber and valve are partly exposed. It will be observed that the valve chamber is slightly larger than the cylinder to afford room for the longer valve travel and wide exhaust cavities. It will also be observed that the parts, as already stated, are readily reached both in assembling and repair, and it may be added that in the most strenuous kind of service so far the valve gearing has been remarkably free from fracture.

#### American Federation of Labor.

Per capita tax reports show that in the affiliated unions there are 2,007,650 members, which makes it by far the greatest federation of labor organizations in the world. Since this report there has been a large increase of membership in the federation.

burner reduces the pressure of gas generated in the "bell" and permits the water to reach the lower surface of the cake in the cake holder. Gas is immediately formed and flows to the burner. If the gas is generated faster than it is burned, the pressure forces the water down in the "diving," or more properly the gas bell, and drives it away from the cake, thus stopping the process of generation and the gas already made is burned before the water can rise and begin to generate gas again. In this way no gas is stored and there is never any gas "in stock" or "on hand." This is the automatic, self-regulating feature which carries its own recommendation with it, and it is a safety measure of the highest value.

The composition of the carbic cake is worth a thought. It is, of course, composed of carbide of calcium, but in its preparation it is treated something like a sugar-coated pill is treated. A substance which makes a protective cover, is made up of two ingredients, one is solu-

#### Prevent Joints from Corroding.

To do this, put up all pipe joints with graphite, use it on bolts and nuts, cover gaskets with it on hand hole plates and use it on all joints and bolts in and around the front ends, and when you want to take the parts down they will come without the use of cold chisel and sledge. In making pipe joints, if some of the graphite gets inside the pipe it flows through as easily as oil, and does not harden into shot to destroy the efficiency of injectors, lubricators and what not. It is the only lubricant that does not burn away, and is especially valuable for wash-out plugs or other boiler joints. Another good point about graphite is that it can nearly always be found ready for use.

#### Effect of Soot in Boilers.

A scoop of slack coal will convert 120 lbs. of water into steam in any well-kept boiler. If the flues and flue sheets are covered with  $\frac{1}{8}$  in. of soot it will only evaporate 66 lbs. of water.

# The Psychology of the Stop Signal

## Man and Machine Contrasted—Imperfect Perception—The Power of Suggestion—A Tried Automatic Stop—Collateral Advantages—Mechanically Produced "Safety First"

This is the age of machines. Gradually there had grown up an undefined belief that all that was needed was a good, carefully designed machine and a man to operate it and all would be well. As time went on, this belief has received some rude shocks, and today there is perhaps a reversal of this opinion. As far as a good man and a good machine can be compared, it is probable that it is safe to say that in the performance of each, the man will fail first. This does not imply that the man becomes tired or that he grows careless. Neither of these things may affect him at the time that he most grievously fails.

We often speak of a machine being "fool-proof," by which we mean that the device can only be put together or operated in one way. By making a machine fool-proof we eliminate free will from the operator. He cannot choose, and to make use of the machine at all, he must do but one thing, and that is to treat the device as it was intended to be treated. Making a machine in this way is regarded as a safety, or precautionary measure, intended to prevent mistakes, and it in no way reflects adversely on a man's mental make up, or his desire to do the correct thing, though it frankly takes cognizance of the fact that he is in a sense not always his own master, and that under the stress of circumstances the task of operating the device correctly may become for the time a task beyond his powers. The fool-proof machine is usually the safe machine.

On any railway equipped with automatic block and interlocking signals, a considerable outlay must have been made. It is on the unexpressed theory that all men are alike and will act alike. The man's mental makeup is tacitly ignored, and though the signals are excellent and properly operated, there is nothing between the indication given by the signal and the act of obedience, except the man himself and his realization of his surroundings and his unerring performance of duty.

Sight is the sense most generally employed to reach such a man. The late Prof. William James says: "The sense of sight is pregnant with illusion \* \* \* No sense gives such fluctuating impressions of the same object as sight does." He then gives a bit of his own experience on the subject. He says: "I remember one night in Boston, whilst waiting for a Mount Auburn car to bring me to Cambridge, reading most distinctly that name upon the signboard of a car on which (as

I afterwards learned) *North Avenue* was painted. The illusion was so vivid that I could hardly believe my eyes had deceived me."

This incident throws a flood of light on the phenomenon, often wrongly deemed remarkable, that a man usually sees what he expects to see. Prof. James did it unwittingly, as detailed in the incident before us. Some years ago a locomotive engineer, on one of our leading railways, had for years run a passenger train, and on one occasion disregarded a red signal, with disastrous results. He stoutly maintained that the signal showed "clear." The investigation brought out the fact that he had not had a signal set against him for over a year. His was an important flyer, and the road was habitually kept clear for him.

Prof. James, speaking of similar happenings, says: "We find most natural to believe that the brain reacts by paths which the previous experiences have worn, and which make us perceive the probable thing, i. e., the thing by which on the previous occasions the reaction was most frequently aroused." The engineman has seen signals for years always clear, and when the solitary red light appeared he saw it; but the mind, overwhelmed by previous experiences, reacted to the probable thing, to him—the "clear" signal, which was the condition by which the reaction had previously been most frequently aroused. The professor is emphatic when he says: "Part of what we perceive comes through our senses from the object before us, another part (and it may be the larger part) always comes out of our own mind."

All this deals with perception, pure and simple, but what potent and supremely overmastering results flow from the almost limitless power of suggestion. An actual railway incident may here be related by which a trivial suggestion by the fireman destroyed the ability of both occupants of the cab to obey a plain, clear and unequivocal train order. Williams and Walker, engineer and fireman, were proceeding west, light, to take the second section of train 374 eastward from a terminal station. They hoped for the train dispatcher's "help" to prevent their being delayed by the first section of train 374. The fireman, Walker, said to Williams, the engineer: "When we get to Brockton, Billy Dean will be at the key, and he will take care of us." Both men thought so, and as time went on the suggestion deepened to firm belief and became a certainty when they received

orders to meet "Second 374 at Brockton." That was the train they were to take out of Brockton, the terminal. The order did not contain a word nor a hint of "First 374." They read the order, but they had previously mentally connected Dean's action only with First 374, and the wrong suggestion of the fireman, trivial as it was, completely obliterated to them the possibility of anything else. Looking for First 374 to be at Brockton, they collided with it 10 miles east of the terminal, and not until the violent shock of disaster had delivered them from the enthralment of the wrong suggestion were they able to see clearly the import of the order they both admitted to have read and misinterpreted on the engine.

Speaking of suggestion, a very eminent living psychologist says: "A suggestion is, after all, any idea which takes hold of our consciousness in such a way that it inhibits and excludes the opposite idea." By exclusion as meant here, it is the reception of one idea and the driving out of the opposite. One must believe he is speaking or that he is silent. He cannot imagine himself as doing both at the same time. Speaking excludes the idea of silence, and silence destroys the thought of speech. The power to resist suggestion varies in strength in different individuals, but in any case it generally requires a strong, often a persistent and frequently an extremely hard, mental operation, and man shrinks from mental effort. Our minds, logical and well balanced as we think them to be, are most vulnerable to the entrance of a suggestion from without, and this is frequently enhanced by individual faulty perception, and the total result, in the form of action, may spell mishap, accident or disaster, yet without in the least implying mystery, disease, or even abnormality. The uncanny power of suggestion lies in the fact that it infects all the neighboring ideas and emotions, and compels or forces the whole mental life of the person under its influence. The catch words of a striking advertisement seek the joints in the armour of mental serenity, and effect an entrance, the power of which is quickly and surely seen in the subsequent actions of the normal but now strongly biased subject.

The failure of the men on the engine due to a trivial suggestion of the fireman may not at first appear to have any immediate connection with the modern stop signal. We must remember, however, that without such an automatic stop, the appeal is made to the man, free to

act or not, and all the time with mind is open to the effects of a suggestion from without, which may not only pervert his mental view, vitiate his continuity of purpose, but completely extinguish his cognizance of objective values, and leave him, at the moment where prompt and correct decision is necessary, without the power to act rationally or to clearly appraise his surroundings. He is at sea in a surging, but unreal, environment, which he mistakes for immovable and rock-ribbed truth.

All this contrasted with the machine and its total want of mentality, acting under the "godhead of blind law," as irresponsible for results as it is for its actions, it is any wonder that man cast in varying individual moulds, the victim of faulty perception, readily open to unwise, often unreal, suggestion, should fail before the machine wears out or becomes dislocated. Mentality, man's highest faculty, may work his most complete ruin without his knowing why. Life as we live it makes many calls upon the mental makeup of man that did not require recognition in the earlier days of the race. Our whole life is in a sense artificial. Our difficulties in this respect may one day disappear as habit and adaptability play their never ceasing part in the onward march of evolution. Now, however, if this be the transition period; the danger in mental processes still exists, and it is but the part of wisdom to acknowledge it, and provide what remedies we may.

When it comes to the automatic stop signal as a remedy, so far as it has been perfected for railway use, one may point to the Chicago & Eastern Illinois Railroad, which has equipped the 107 miles of double track road between Danville and Chicago, Ill., with a train control apparatus, and the railway has operated this automatic stop device for about three years, so that it is fair to say that the whole has passed beyond the experimental stage. The road is equipped with block signals supplied by one of the leading signal companies, and these signals can be used with advantage with this stop control. The locomotive equipment is interesting, and forms one more of the pneumatically actuated appliances carried on the locomotive. The great problem to be solved in connection with automatic train stops was in this case found to be the difficulty in getting proper electrical contact between the engine-shoe and the ramp. Any failure to get proper electrical contact caused the control mechanism to stop the train. This difficulty has now been practically overcome. In any case a failure causes delay but avoids disaster.

In designing the locomotive cab equipment it was believed that the best results could be obtained by applying the control mechanism in such a manner that it would

automatically handle the engineer's brake valve. The cab mechanism does not interfere with the engineman's duties in running the train. The control operates automatically, governs the brake valve and moves it to a predetermined position. The same movement closes the throttle. The engineman has to release the brakes in the usual manner, after a stop has been made, and he also releases the throttle-holding device at the same time. When the brakes are applied and the throttle closes they remain in this position until released by the engineer. The engineman is compelled to release his brakes in the same manner as if the control was not on the engine. The release is therefore the result of a definite, purposive act on his part.

Trains as they travel, pass over ramps placed at the side of the track, and the shoe and primary valve, as it is called, are operated by the ramp. The contact shoe is raised vertically, and this opens the along the ramp. This upward movement of the shoe unseats the primary valve, and the raising of this valve allows air to escape from a pipe which communicates with the control mechanism. The ramp is a tee-iron about 180 ft. long, and the sharp side of the tee is uppermost. There is a gradual rise of about 3 ins. in 90 ft., and also a corresponding decline. The center of the ramp is about 6 ins.; above the top of the track rail, and the shoe on the engine is so arranged that it gives the shoe about 3 ins. maximum lift.

When engaging with the ramp, the shoe is raised vertically, and this opens the valve, already referred to, which allows the air behind it in the pipe and connections to escape to the atmosphere.

The air pressure which is on top of the brake valve control piston forces it downward, and this brings the brake valve handle to the service position. When the main piston has traveled to its lowest position a small air valve on the top of the control is opened, which admits air to the throttle cylinder, thereby closing the throttle.

As soon as the shoe leaves the ramp the primary valve, mentioned above, closes; air pressure quickly builds up through the small feed port in the control valve chamber, and when the pressure has equalized the brake valve mechanism and the throttle-closer device, automatically return to their normal positions, but leave the throttle closed, and the brake valve in the service position. The engineman must then, and with intention, release the brake and open the throttle for a fresh start.

When the track ahead is clear the ramp is electrically energized, and when the shoe engages the ramp a current of electricity travels from the shoe along an insulated wire to the control magnet, or solenoid. The action of the electric cur-

rent forces the control valve against its top seat, thereby preventing a reduction of air below the brake valve control piston, so that there is no action of the brake valve, and the throttle closing mechanism is not called into play. The opening of the primary valve, which always takes place when the contact shoe is pushed up, going over a ramp, causes a whistle with deep note to sound, and this calls the attention of the engineman to the fact that the ordinary block signal connected to the ramp shows "clear," and that the control mechanism is working properly.

The use of such mechanism removes from the engineman the danger of mental failure. It does not prevent him from seeing and obeying the signals, but it emphatically prevents him from making a wrong interpretation of what he sees, and it delivers him from the effects of tardy, confused or impulsive action. He may stop the train when emergency demands, if he acts properly, but he must so act, or the unintelligent mechanism gliding over the ramp will do it for him.

Mechanical appliances of any kind, even if deranged, can be made to fail always on the side of safety. A man's failure is not habitually in one direction, and his action cannot be foretold, and for this reason the superiority of the machine is of the greatest value. It is the mechanical expression of the "safety first" idea, with all the benefits which that involves.

Several curious, and, one might almost say, collateral improvements have made their appearance where such a system is in vogue. The necessity of keeping the track clear of obstructions by the side of the rail in order that the contact shoe may not be lifted at the wrong place, has a tendency to focus attention on the road all round, and closer inspection follows, and a defective tie may be removed or a loose bolt tightened or a low joint raised. Better maintenance of the air brake takes place at terminals, almost without specific direction, so that leaks in the train line added to the loss of air in the service application shall not give a violent or an emergency stop when a halt is necessary. The system causes the interlocking plant operator to be prompt, because report of a detention is not left to the discretion of the train crew, but is obligatory, so that no "standing in" on the part of a dilatory operator can cover up his want of alertness or hide the loss of time to the train. The movement of traffic is facilitated in foggy or thick weather by reason of the ramp being so placed as to be encountered several hundred feet before the signal is reached and the low-toned "all clear" whistle gives the engineman timely warning as to the condition of the signal he is approaching. In fact, the whole safety first idea is "in the air," and reacts as a highly beneficial mental suggestion to all concerned.

The good office performed by the auto-

matic stop signal is easily apparent, yet it implies not even a hint of incapacity, carelessness or neglect in the intention and the faithful regard for duty which the overwhelming majority of engineers undoubtedly have. Its function is a valuable aid, and its work consists not of robbing the engineman of justly and ably carried responsibility, but where, by reason of momentary distraction, or the insidious entrance of a wrong suggestion or the imperfect perception of an object seen for a moment from a flying train, he may fail, even with the very best intentions. Here it is that the automatic stop adds its potent help, and promptly puts a steady 1,000-lb. pull on the brake rods at the opportune, vital moment, wards off the impending danger and brings back mental action to its normal state by the simple process of unknowingly but mechanically producing the imperatively demanded condition of safety to train, to crew and to the passengers who have trusted their lives and themselves to the careful work of transportation by the railway company. The certainty of delivery from the menace of disaster and death is above price.

#### Preparing for the Winter.

Some railroads have already taken the precaution to prepare for winter while yet the sun shines bright in the autumnal days. Others may have been forced to forego this necessary work owing to pressure of important and paying traffic. July is a good month to repair snow ploughs, but even now it is not too late to ascertain if all the snow-fighting paraphernalia is ready for use and in serviceable condition.

The modern railroad has all sorts of buildings to heat, roundhouses, car repairing shops, oil tanks, stores and a host of others; its cars have to be efficiently cared for so as to be ready for the uncertain advance of cold weather. Some have been predicting a hard winter, and though the pessimist is not a pleasant person as a rule, it may just happen that he is right. Drainage of pipes and reservoirs and receptacles becomes now a matter of serious concern. Unused passenger coaches may have had their drain cocks open as they stood unused all summer and yet freeze and develop some awkwardly placed broken pipes. All this, we say, may happen to cars which are said to have been drained out, and yet were not, because they stood on badly made and uneven sidings, capable of carrying them but not able to maintain them "on an even keel."

We utter this word of warning having in the past known of some close shaves in the way of winter preparedness, not because work was neglected, but because all that might happen had not been taken in at a glance.

## Selecting Feed Water for Locomotives

By Angus Sinclair

I happened to go through my first experience of locomotive operation in a portion of Scotland noted for scale forming feed water, and so early in my career was made familiar with processes carried on for the purpose of softening the water introduced for boiler locomotive use.

The first position of engine running which I obtained in this country was on the Chicago, Clinton & Western Railroad, a road nine miles long, originating in Iowa City. I had one engine and made three round trips a day. That is a Devonian limestone district, and produces intensely hard water. I drew water from a sunk well at first, but finally observed that the hard water caused leakage to my firebox. To remedy this, I made a steam syphon and took water from a running brook with good results.

In those days I was ambitious to obtain a scientific education, and succeeded in attending the chemistry classes of Iowa State University, which is located at Iowa City. While pursuing this line of study, I did my best to give it practical application, and, among other practices, analyzed all the water in the neighborhood.

When I had been attending the university classes about two years, the Burlington, Cedar Rapids & Northern Railroad, now part of the Rock Island system, bought our small road. My operations were put under supervision of the Burlington, Cedar Rapids & Northern officials. A few weeks after these officials took charge, the inspector of water stations visited me and said that he had come to arrange for sinking a well to supply my engine with feed water. I advised him against putting a well down, as the water to be so obtained was too hard for boiler use, and showed him some superficial tests to indicate the difference between soft and hard water. A curious thing about this was that the man who was supervisor of water stations was not aware that there was any difference in the water supplied for boiler purposes.

He went back to headquarters and reported to the president of the railway, and that official remarked: "If that man Sinclair knows as much about water as you say he does we want him here, for hard water is ruining our locomotive boilers."

He sent an engineer to relieve me next day, so I went and had an interview with President Ives. The result of the interview was that I was appointed chemist of the company, with orders to make the examination of water stations my first duty.

When I got my laboratory in work-

ing order, I sent to all the water stations for a specimen of the water used. I made a superficial test of all these and found some of the water to be remarkably hard. The worst specimen came from Burlington, Iowa, so I went to the place to see if any change could be made. I found that they were drawing the water from a well two hundred feet deep on the bank of the Mississippi River. The water held over one hundred grains of sulphate of lime to the gallon, the worst kind of scale forming element. I made them take the pipe out of the well and push it into the river, which had about nine grains of solids to the gallon.

When the hard water was in use, a boiler maker was kept at Burlington to maintain the boilers of three switching engines in working order. A month after the river water was brought into use, the services of the boiler maker were dispensed with.

I proceeded systematically to reject the stations where the water was particularly hard, many of the changes having been made by taking water from running streams instead of from driven wells. The people who originally located the water stations paid no attention whatever to the character of the water, a degree of ignorance that proved very expensive to the company. When the system which I supervised was in operation about a year, President Ives made public a statement that the selection of feed water had resulted in saving about 20 per cent. of the fuel formerly used by the engines.

#### American Locomotives in Russia.

A Kharkof newspaper writes, under date of August 30, 1916, that Prof. Lomonosof, a member of the engineering board of the Russian Ministry of Ways of Communication, has established a new European record for the most heavily loaded train. With the American locomotive of the decapod type he brought over the Nikolaief division of the Southern Railway a train with a load of 4,424 tons. The length of the train was 2,800 feet. The signaling was done with flags, as is the custom in the United States. The trip was experimental. A Russian engine was tried out against the American engine, and the superiority of the latter was clearly established.

#### Peruvian Railway Enterprise.

By a decree dated September 9, 1916, Jose Balta was given authority to undertake the preliminary investigations for the construction, in the Department of La Libertad, of a railway which, when completed, will connect the rich mineral field of Sayapullo with other railways.

# Empty and Load Brake in Grade Service

By W. V. TURNER, Assistant Manager, Westinghouse Air Brake Company

In last month's issue, the advantages of the empty and load freight car brake was dwelt upon at considerable length, and in grade service the improvements of this brake are even more apparent. In descending a grade a certain portion of the car weight is acting to accelerate it. This portion is equivalent to the per cent. of the grade, that is, on a two per cent. grade, two per cent. of the weight of this car on this grade is tending to accelerate it. Thus if the car weighs 100,000 lbs., 2,000 lbs. is acting to accelerate it down the grade, and if this acceleration is not to take place, an equal opposing force must be brought into play to counteract the accelerating force.

The internal friction or resistance of the car provides a part of this opposing force.

If this resistance is taken at 8 lbs. per ton, a grade of 8/2,000 or 0.4% is required for the accelerating force to just equal the internal resistance. The 2% grade will cause a net accelerating force of 2.0 - 0.4 or 1.6% of the weight of the car. It is as though the car was without any internal resistance whatever and stood upon a 1.6% grade. In figuring train control on grades, it is necessary, therefore, to consider the internal resistance of cars, but this is neglected in figuring stops for the reason that many tests have demonstrated that in bringing a car to a stop the internal resistance is just about equal to the force required to overcome the rotative energy of the wheels. In the subsequent formula given for stop distances, it will be observed that no allowance is made for either the rotative energy of the wheels or the internal resistance.

In controlling a car on a grade, the rotative energy of the wheels does not change, practically speaking, and therefore the internal resistance operates in the direction of overcoming the accelerative force due to grade.

The retarding force set up by the brakes on a car, is in terms of the car weight equal to the braking ratio multiplied by the brake rigging efficiency and by the coefficient of brake shoe friction. Thus, if a loaded car equipped with a single capacity brake has a braking ratio of 15%, a rigging efficiency of 85% and a brake shoe friction of 15%, the retarding force will be .15 times .85 times .15 equalling .01915 or 1.9% of the car weight. That is, the retarding force will just equal a net accelerating force of 1.9%, or one due to a grade of 1.9 plus 0.4 equalling 2.3%, making the above allowance for internal resistance. But this would provide no reserve, no margin

for safety or flexibility, because it would necessitate a constant cylinder pressure of 50 lbs. (the basis for the braking ratio mentioned) all the way down the grade. Leakage, recharging and ability to come to a stop when desired would be quite uncared for. Considering time for recharging, length of train, reserve power for making a stop, leakage, etc., the cylinder pressure will average only 30 lbs. for the entire descent of the grade. This means that the retarding force will be only 30/50 of 1.915 or 1.15% and the maximum grade corresponding, 1.15+0.4 or 1.45%. Making the same allowance for the empty and load brake, we find the maximum grade to be,

$$G = .40 \times .85 \times .15 \times 30/50 + 0.4 = 3.46\%$$

### CONTROL OF LOADED FREIGHT CARS ON A 2.3% GRADE.

Total Weight of Loaded Car	208,000 Lbs.	Nominal Braking Power	Empty Car Std. 10%
Brake Rigging Efficiency	85%	" " " " " " " " " " " "	Loaded Car Std. 15.3%
Average Coefficient Friction	15%	" " " " " " " " " " " "	Empty Car E & L 10%
			Loaded Car E & L 40%

### FORMULAE:

Retarding Force = weight × Braking Force × Rigging Efficiency × Coefficient Friction	208,000 × (.85 × .15) × .15 = 3,103 lbs.
Accelerating Force = Weight × Per Cent Grade	208,000 × .023 = 4,784 lbs.
Effective Accelerating Force = Accelerating Force - Retarding Force	4,784 - 3,103 = 1,681 lbs.
Acceleration = Effective Accelerating Force ÷ Mass	1,681 ÷ (208,000 ÷ 32.2) = .26 Ft. Per Sec.
Velocity = Initial Velocity + (Acceleration × Time)	29.40 (= 20 M. P.H.) + (10 × .26) = 32.00 (= 21.76 M. P.H.)
Distance = Average Velocity × Time	(29.40 + 32.00) ÷ 2 × 10 = 307 Ft.
	Initial Velocity <sup>2</sup> (Ft. Per Sec.)

$$\text{Length Stop} = \frac{2 \times 32.2 \times \text{Rigging Efficiency} \times \text{Coefficient Friction} \times (\text{Braking Force} - \frac{\text{Per Cent Grade}}{\text{Rig. Eff.} \times \text{Coef. Fric.}})}{29.402} = 477$$

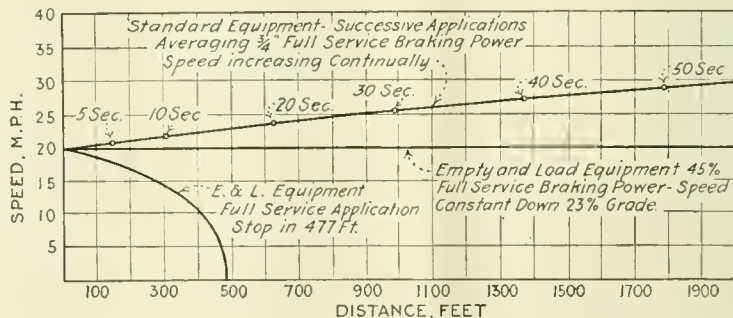

DIAGRAM OF EMPTY AND LOAD BRAKE.

You will notice that these limiting grades stand in approximately the same relation as to the braking ratios for the two types of brakes. In each case approximately the same factor of safety holds good. That is to say, the empty and load brake is as safe on the 3.46% grade as the single capacity brake is on the 1.45% grade, the only difference being, as will later be shown, an increase in air consumption of 17% for the empty and load brake.

The empty and load brake will control a train of loaded cars on a certain grade with only one-half the air consumption required by the single capacity brake with the same train on the same grade. This, in itself, shows how marvelously more flexible, more safe and more economical the empty and load brake is.

This reserve may be utilized by handling a train with the empty and load brake twice as long, other things being equal, as the empty car brake train and with the same factor of safety.

The loaded train equipped with the empty and load brake will stop in 15/40 or 37.5% of the distance required by the train with the single capacity brake.

All of the foregoing computations may be briefly summarized in mathematical form.

For limiting gradient:

$$(1) G = \frac{p P W E e f + r T C}{W C}$$

For average brake cylinder pressure required to control car down gradient G:

$$(2) p = \frac{(G W - r T) C}{P W E e f}$$

EXAMPLES:

$$(3) S = 1.467 V t + \frac{W V^2}{30(p/C P W E e f - G W)}$$

where:  
 S = stop distance, in feet.  
 V = initial velocity of car, miles per hour.  
 G = gradient; + downhill.  
 - uphill.  
 P = braking ratio, based on  
 C = basic cylinder pressure for P, lbs. per sq. in.  
 p = average cylinder pressure (for grade computation) or  
 = actual cylinder pressure (for stop computation).

$W_E$  = empty weight of car, basic for P and C, lbs.  
 $W$  = actual weight of car, lbs.  
 $T$  = Weight of car in tons.  
 $r$  = internal resistance of car, lbs. per ton.  
 $e$  = efficiency of brake gear, averaging about 85%.  
 $f$  = coefficient of brake shoe friction, ranging from 10 to 20%.  
 $t$  = average time train may be considered running free before the brakes get into action. This may be neglected for freight train computation.

$P_L$   $W_L$  may be substituted for  $P_{WE}$  where an empty and load brake is in use. In this

$P_L$  = loaded car braking ratio  
 $W_L$  = loaded car weight.

If  $p = C$  and  $W = W_E$  formula (3) becomes greatly simplified:

$$(4) S = 1.467 \sqrt{t} + \frac{V^2}{30 (P_{ef} - G)}$$

If  $t$  be neglected and  $G$  s., i. e., the stop be made on a level track

$$(5) S = \frac{V}{30 P_{ef}}$$

It will be noted that speed does not appear in the gradient formula. This is because no more retarding force is needed to hold a train down a grade at a speed of 40 miles per hour than at 10 miles per

hour, but it is harder to get this retarding force at 40 miles per hour than it is at 10 miles per hour because brake shoe friction is much less at the higher speed due to the higher velocity of the wheel surfaces and the greater brake shoe heating. Therefore the allowance for speed must appear in the value of the coefficient of brake shoe friction used.

The average brake cylinder pressure needed to provide the necessary retarding force is the average between all minimum pressures occurring while the brakes are released (retainer pressures if retainers are used) and all maximum pressures occurring while the brakes are applied.

The attached diagram sums up in a graphic way the advantage the empty and load brake offers in grade service. The train equipped with the single capacity brake, averaging 75% of the full service braking power (average cylinder pressure of 37.5 lbs., an assumption really too high) is running away on the 2.3% grade. In less than a minute's time its speed has increased from 20 to 30 miles per hour. The train equipped with the empty and load brake holds to the constant speed of 20 miles per hour with but 45% of the full service braking power (average cylinder pressure of 22.5 lbs.—a very conservative assumption), and its reserve braking force enables it to stop from this speed in less than 500 feet which is satisfactory.

bracket supports, and the necessary placing of copper pipe connections and leads from the brake valve it is often almost an impossibility to reach the nuts or body bolts with any kind of a monkey wrench or small open end S wrench. The crow-

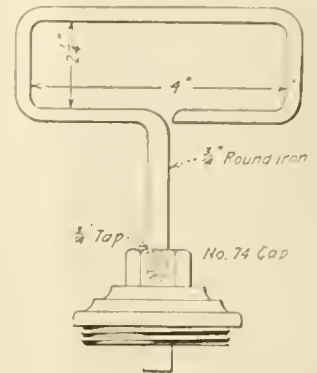

FIG. 1. JIG FOR TOP HEADS OF AIR PUMP.

foot wrench for nuts located in places difficult to reach is generally an old and commonly used tool, but the writer made the wrench a little more convenient, for this purpose in particular, by attaching a handle to it so that the handle is a non-detachable part of the tool itself. It will be observed that about 1 1/2 in. from each end of the wrench the square of the shank is turned. This makes it possible for the handle to be moved up on the square, turned and again slipped down when another draw is taken on the crowfoot wrench. This may be readily accomplished while making the wrench by cutting it in the center, dropping on the handle over one of the halves before welding the two together. This completes and affords a continuously inseparable handle. The turned portions may be

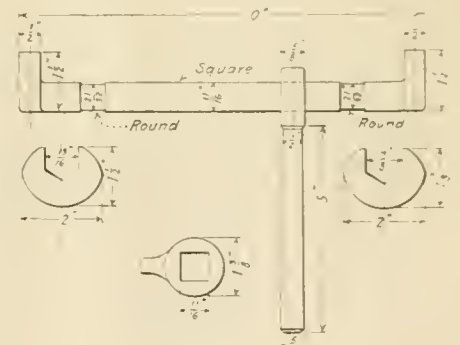

FIG. 3. DETAILS OF BRAKE VALVE WRENCH.

easily cut on any small lathe, or may be filed out without a great deal of trouble, if necessary. The two ends or openings are adapted for either size of the 1/2-in. nut, as owing to breakage or stripping a large number of standard nuts are found to be applied to valve bodies, and, of course, are as good for all practical purposes as the W A B parts. The convenience of the tool will quickly be appreciated on hurried cleaning or repair work to G-6, H-6, or S-6 W A B brake valves.

## Handle for Lifting Top Heads of Air Pumps and Wrench for Brake Valve Body Bolt

By F. W. BENTLEY, Jr., Missouri Valley, Iowa

A great saving is effected by the use of handy tools, especially in the unloosening of the more delicate parts of the smaller appliances used on the modern locomotive.

Fig. 1 shows a very cheaply constructed jig for handling the top heads of a 9 1/2-in. air pump. In hurried roundhouse work, where top heads are taken from hot engines, it will be found very convenient in handling the heads under conditions when they cannot be comfortably or safely removed even with heavily gloved hands. It combines a factor of safety, also, as lifting the heads from the floor to running board is frequently a difficult and dangerous hoist with a lone head. A considerable number of accidents has resulted on account of no proper facilities being at hand to lift the heads under the conditions generally surrounding roundhouse work. As shown in the drawing the handle is constructed of 3/4-in. round iron.

Fig. 2 shows a reproduction of a photograph of a similar jig which may be used when air pump heads are shipped from central to outside points. It will be appreciated by all who must move the appliance in transit. It is, of course, applied to the B O head and returns with it to the main shop.

Fig. 3 shows the details of a very convenient brake valve wrench in running repair work. Owing to the location of



FIG. 2. JIG FOR HANDLING AIR PUMP HEADS IN TRANSIT.

## Device for Reseating Rams of Ohio and Simplex Injectors

By E. L. BOWEN, Air Brake Foreman, Illinois Central Railroad

The time lost in what may properly be called the running repairs of the ordinary mountings of the locomotive boiler is not owing to the lack of skill of the experienced mechanic, but is owing in a great measure to the lack of special tools adapted to meet the requirements of the case. If the circumstances attending the job were unusual and particular, there might be a reasonable excuse for the lack of special tools, but as the same need of

The accompanying drawing shows the details of a device for reseating the steam rams of Nos. 8, 9, 10 and 11, Ohio and Simplex injectors. Referring to the drawing, cutter A, with pieces F and D, are used with frame C—which is held in vise—to reseal Ohio injector rams, and also cutter B, piece G, E and clamps H, are used to reseal Simplex injector rams. This device does the work much quicker and even better than is usually done in a

trying to do for their son, so it becomes necessary for the apprentice school to train the young man in such a manner that he will unconsciously take to the teaching and get so interested in his work and study that he will voluntarily give up his old habits trying to better his condition.

When the apprentice schools were first installed throughout the country it was thought that a regular course of training would fit the average boy to become the ideal mechanic, but it was found that while a boy would be interested and attentive in his school work, after he had graduated he would soon lose his interest and there would not be much benefit of his training, so it became necessary to put forth some new idea to not only hold his attention as an apprentice, but to retain that same interest in his work when a mechanic.

The very first day an apprentice starts to work at his trade he should be given to understand he is now one of the "men" of the plant and must produce his share of the work in order to earn his wages and maintain the reputation of the place. The first impressions formed will be far more lasting than usually expected, and if a young man is allowed to go about the shop at his own discretion the first six months he is employed as an apprentice, he will form habits that will follow him throughout his employment. Every job, no matter how small or insignificant, has responsibility, and if the boy is early taught the responsibility of small things, he will naturally know that larger jobs are more important. Is it not a fact that men are chosen for positions as foremen because they are steady and reliable, and if we expect these things from a foreman, why should they not be so trained from the beginning, as apprentices?

Another very valuable point to be considered in the selection of apprentices is to get the "right" boy and by putting the boy "up against it" the very first day he is employed, he will see that learning a trade is not all play and if not made of the right material will look for a job elsewhere so that after a few months of "trying out" it won't be necessary for the shop force to recommend his discharge because he has gone "stale" on the job or else is lazy and won't work. Many boys start in to learn a trade with a rush and after the novelty has worn off, they become indifferent and unreliable. If the weather is a little cold, they will stay in bed and won't get around to work till an hour after the regular shop hours begin but on the other hand if they are given to understand their services are required to get out some certain job on schedule time, the chances are that when the shop opens in the morning, they will be right on the job.

The observing powers of the boy should be developed all that is possible for of-

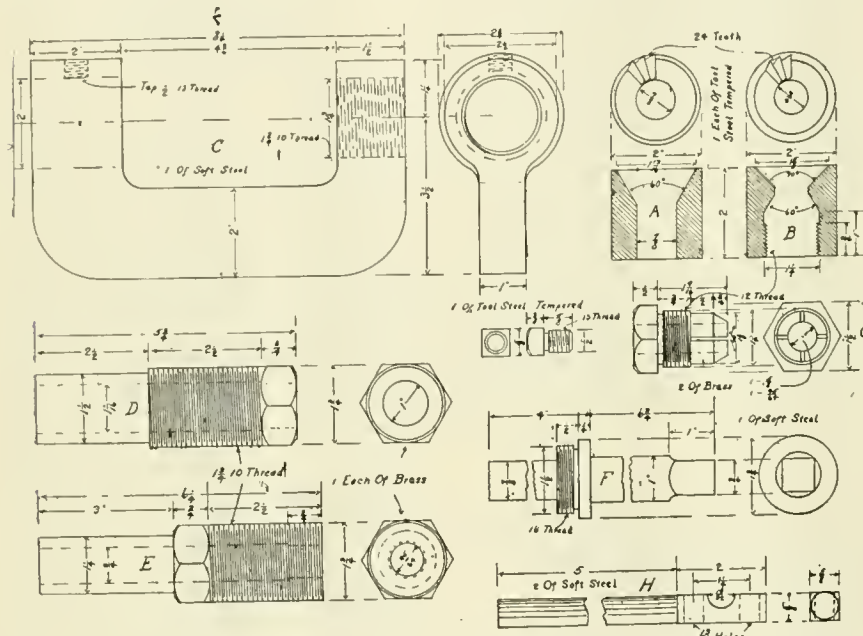

DETAILS OF DEVICE FOR RESEATING RAMS OF OHIO AND SIMPLEX INJECTORS.

repairs of the same parts are constantly occurring, there is no good excuse for the lack of tools to meet the situation. On many railroads there is no time to give attention to the construction of special tools, and slow and imperfect methods of repair are the result in many cases. On our road the encouragement to devise special tools for special purposes is of the best, and the fine equipment of shop tools is constantly being added to.

lathe, and is especially useful in a round-house, and entirely precludes the frequent necessity of losing time waiting for a machine that may be occupied in some other work, and cannot always be stopped for use on work that may be, in the very nature of things, casual and incidental. The parts are not difficult of construction, and when made and properly tempered, will last through many years of service.

## Modern Apprentice Schools

By H. L. BURRHUS, Apprentice Instructor, Erie Railroad

The modern and up-to-date apprentice school has found that its success does not depend entirely on the teaching of skill and proficiency in handling the regular shop tools and machines, but that the perfect mechanical education consists of a complete harmonious development of the whole man in his threefold nature—physical, intellectual and moral: hand, head and heart. Any system that fails

to take into account any one of these three is worse than useless; it is hurtful, for it distorts the man. The success of this training is retarded to some extent, for the apprentice is not big enough to thoroughly understand why any company should be interested in his daily habits after he has left the shop at the completion of his day's work, or the parent does not appreciate what the company is



ten we hear that old excuse "I did not notice." It is impossible for any apprentice to "learn it all" during his apprenticeship and it can be truly said that all he does learn, in reality, is to keep his eyes open. Some of the oldest mechanics will tell you that they are learning every day of their life, therefore too much stress cannot be laid on the value of teaching "observation." Dr. Angus Sinclair, one of the most famous mechanical men living today, delights in telling the story about himself when he first started to learn the trade over in the old country, of how he was working in a boiler with an old time mechanic and after they had completed their job and had climbed out of the boiler, the mechanic asked him how many boiler tubes there was in the boiler. Of course, being young and inexperienced at the business, he did not know, so the mechanic made him go to the trouble to climb back in the boiler just to count the number of tubes. This taught him the lesson to always keep his eyes open, a lesson which he always remembered.

The Erie Railroad, one of the foremost railroads in industrial training for their future mechanics, has proven that to develop the "ideal" mechanic, he should be given actual and practical shop instruction along with technical instruction. It is a fact that every apprentice will not become a draughtsman or mathematician but he is to become a loyal and faithful workman and he should be developed along these lines. Recently, this company

assigned an engine that was to be rebuilt from a compound type to a simple type and overhauled for passenger train service, to one of their large apprentice schools; the understanding being that all the work was to be handled by apprentices alone. The result of this test was most gratifying not only from the actual experience it gave the "boys" but from the fact that the work was handled in such an efficient and economical manner that it would have been a credit to any of the regular erecting shop gangs. The "boys" proved that their training on "self-reliance" and "responsibility" did not desert them when placed on their own resources and that their enthusiasm as apprentices was just as apparent when handling regular assigned mechanics' work. Continuing their valuable training for their future mechanics, this same road has arranged to have each of their three largest apprentice schools build a complete new switch engine, every job to be done by an apprentice boy and under the supervision of an apprentice boy. Is there any better way to find out "what is in a boy"?

Look ahead at what you want 5 or 10 years hence and not "drift" along day by day. Remember the world moves fast and it will get away from you, if you don't watch out. The man who plans on the future, by doing the most with the present, will not suffer failure because he will have confidence and enthusiasm trained into him when he was an apprentice.

conforms with that of the connecting lines over which trackage rights are maintained. Outside positive conductor rails, at about 600 volts pressure, are used to supply collecting shoes on trains. A negative rail is provided between the running rails, which latter may be used for track circuiting.

#### Questions to Be Answered by Readers.

*Editor, RAILWAY AND LOCOMOTIVE ENGINEERING:*

Will you kindly publish answers to the enclosed questions, if you consider them worthy of space, in the columns of your magazine? And will you publish this letter so that those who can reply may have an opportunity to do so?

(1) Let those who know tell of the result of any observations or investigations that may have come to their notice concerning the merits of a tube expander, known in Canada as the "Prosser," named, I presume, after the inventor. Much difference of opinion exists here as to the results obtained from its use as compared with the results obtained from the use of the ordinary roller expander, and I should like to have the views of one or more disinterested persons who have had experience with both.

(2) Information regarding the construction and operation of the Young locomotive valve gear. I understand that the Grand Trunk Railway Company, with whom I am employed, have two or more Pacific type superheaters equipped with it and I hear that they are giving far better results than others of the same type equipped with either Stephenson, Walschaerts or the Baker-Pilliod gear. I would like those who have some information of these valve gears.

As a locomotive engineer, handling superheater engines in passenger service, I am greatly interested in all matters pertaining to their construction as well as to the best method of operating them. I have found out from my experience, which is quite limited with the superheater, that the matter of lubricating the steam chests and cylinders is one of the greatest importance, and to successfully accomplish this, a properly designed drifting device is absolutely essential.

I have yet failed to see or read of one that, to my mind, will operate satisfactorily in our Canadian winter. The Wyman device, which was described in your August number, looks to me as if the source of supply is all right but the method of conveying the steam to the steam chests is all wrong.

I should imagine that while working steam that the auxiliary pipe would fill with water from condensation, then with throttle closed this volume of water would be injected into the steam chests and cylinders washing away whatever lubricant had been therein deposited.

## An Electrification in England

By ROBERT W. A. SALTER, London, England

October 1 marked the first stage of another great electrification undertaking in the vicinity of London, when the London & Northwestern Railroad Company inaugurated for electrical operation 16½ miles of line between Broad Street Station, London, and Richmond (a suburban

The leading particulars of the new equipment installed is as follows:

Standard rolling-stock employed comprises 3-coach and 6-coach trains; each 3-coach train consisting of a motor-coach, a trailer, and a driving trailer, with control on the multiple unit system. The



ELECTRIC TRAIN ON THE LONDON & NORTHWESTERN RAILROAD.

town), as well as a branch to Kew Bridge. Similar undertakings had recently been put into operation by other railroads on their lines in and around London and the Northwestern Company felt the effects of competition. The photograph reproduced shows one of the latest electric trains.

generating station at Stonebridge Park provides an initial capacity of 25,000 KW.; and adjoining it are repair-shops for electrical rolling-stock. There are 11 sub-stations at various points along the lines; these, however, are not all required yet. Electrical equipment of the tracks

Again, what would prevent the auxiliary pipe from becoming frozen during severe weather? I quite agree that it is absolutely necessary to have a sufficient volume of steam in the cylinders to prevent the formation of a vacuum so that the introduction of gases and cinders may be caused and the carbonization of oil may not take place, and that it is hard to maintain the required flow with the throttle and, at the same time, make the nice smooth stop that is so much desired.

However, I do the best I can to keep sufficient steam flowing into the steam-chests to prevent the relief valves opening, and close the throttle only when stopped. I have also discontinued the use of the cylinder feeds on the lubricator, feeding from five to six drops of super-heater oil through the steam chest feeds per minute, which I feel is quite ample under these conditions, our speed averaging forty miles an hour. I might add that the cylinder heads were removed some time ago for the purpose of examination, and just a slight film of carbon was found, whereas it was formerly found necessary to scale it off. I hope your readers will give me the benefit of their experience.

BYRON BAKER,

Sec'y Dom. Legislative Board B. of L. E.

### High-Speed Tool Steel.

In a railroad repair shop using high speed steel, the performance was excellent. The tool literally "hogged" the metal off, the cut being, on the average  $\frac{1}{4}$  in. deep, and the feed  $\frac{1}{4}$  in., and the speed 13 ft. a minute.

The search for a cause brings us to the factory of William Jessop & Sons, Sheffield, Eng. This firm buys the entire output of one mine on the continent, from which the highest grade of Swedish iron comes. This kind of material is regarded as the purest form of iron in the world. From this high grade Swedish iron the Jessop firm makes blister steel. Having made it, they sort the blister steel into grades, in which what they call "through" steel is at the top. This name refers to the fact that the carbon in the blister steel is distributed all through the bar and is, as nearly as may be, fully chemically combined with the iron. The lower grades show the penetration and combination to be less deep, always leaving a more or less extensive pure soft iron center. The tool steel, however, comes from impregnated blister steel.

The next process is sorting. The blister bars are cut into short pieces, and all the pieces which show the homogeneous structure of "through" steel are thrown into a number of crucibles ready to receive them. The bars which show less penetration of the carbon are put aside for other uses. The process of sorting is carefully carried out; so that the crucibles are filled with a high grade ma-

terial, treated so as to have the highest grade of carbon impregnation, and some responsible man sees to it that what is desired is actually there.

The "through" blister steel is melted in the crucibles, and a busy squad of men skim each crucible and pour the contents, practically all together, into a large ladle. The ladle is skimmed and the contents poured into an ingot mould. The ingot moulds are made in halves and the joints are separated by strips of metal. The strips are held temporarily in place with the half moulds by clamps. While the metal is hot and viscous, that is while it is pasty, the metal strips are drawn out and the half moulds are forced together by hydraulic pressure, using what is called the Robinson-Rodgers method as applied in the Jessop shop.

The effect of the 100-ton hydraulic pressure on the ingot is to prevent the formation of "pipes" in the ingot, and to push any impurities out at the end, and thereby insure the formation of a very close-grained, homogeneous, dense structure, of the very high quality from which the tool steel made by the firm is noted. Bars of various sizes of tool steel are made from the ingots, but, large or small, the quality is the same.

The use of high grade tool steel in the railway shop insures that more than half the battle is already won if the steel stands the strain and does the work. In a performance where this tool steel turned one-hundred, 33-in. steel tires, with a  $\frac{3}{8}$ -in. cut, a  $\frac{3}{8}$ -in. feed at a 13-ft. speed, it only lost three ounces by regrinding. This is evidence that the pressure on the cutting edge of the tool must have been exceedingly heavy. Not only has the cutting edge to stand the strain and maintain its shape, but from the very nature of the case any lathe tool has to be held in a position which would not usually be justified as good engineering in sustaining a weight, if it were not for the fact that there is practically no other way to do it. The strain in the body of the tool tends to carry down the point and tilt the other end up.

As a rule, one may say that if the point of the tool is hard enough to maintain its efficient cutting qualities for heavy work, extreme hardness does not help the body of the tool to carry the load or stand the enormous pressure of the down-thrust at the point. The importance of the preparation of the tool point to stand this downward pressure would indicate that attention should be paid to the front and side rake of the point for heavy work. The whole matter requires careful adjustment, so that while the tool is suitable from one point of view, it may not fail owing to lack of care at another. The make-up of this grade of high speed tool steel is such that practically each of these divergent characteristics are provided, and the tool cuts well, and stands well, and is altogether highly efficient.

### To Put a Headlight in Proper Order.

A valued correspondent having asked some questions concerning the care of headlights and how to put in proper order a headlight in bad shape, wick burned short, air passages around the burner and wick tube full of dirt, altogether a headlight in a poor condition.

In the first place, empty the oil tank, rinse it out with clean oil, see that the oil pipe between the wick tube and oil tank is open and clear of sediment. If it leaks around the shaft of the little cog wheel that turns the wick up, put some candle wick packing in the nut and don't screw it too tight. If the oil tank leaks, now is the time to have it soldered. The pipe to let air in the top of the oil tank should be high enough so that oil will not spread out. An air hole large enough to pass through a small needle is large enough if ripped open. A large oil hole lets the oil slop up around the loose wick.

A knit or felt wick is the handiest to put in, as they are made of the proper size. Put the wick in smooth and even, tie it at the bottom around the wick holder with fine linen thread with a small knot so that it will not crowd the wick against the other side wick holder. After getting the wick so that it can be raised or lowered easily run it clear down and burn off the top even with the top of the wick tube with a small piece of red-hot iron, then fill the tank with oil. See that all the holes and air spaces about the burner and the air hole up inside the wick are wide open and perfectly clean. The supply of air inside and outside the flame must be adjusted or it will smoke. If the flame strikes the chimney, too much air comes up inside the flame around the button. If it runs up straight and close to the button there is not enough inside. A new headlight has a slide at the bottom of the inside tube to shut off the air supply when necessary. If this slide is gone, get a cork large enough to fill the hole and cut big notches in its edge to permit a sufficient supply of air past it.

See that the springs on top of reflector are bent so as to hold the chimney square with the burner, and keep it from striking the edge of the hole in the reflector when running. Then use oil and fresh lamp black to clean the reflector. Do not use tripoli, whiting or patent polish on the reflector. The silver coating is thin enough without scouring it off. When the reflector is done, clean case thoroughly.

### Railroad Inquiry.

Government ownership of railroads will come up for consideration before the investigation of the joint Congressional committee into the transportation problems of the United States, which will open on November 20. Senator Newlands, of Nevada, whose resolution provided for the inquiry, is the chairman of the committee.

# Excellent Record of Steel Freight Cars Built by the Pressed Steel Car Company

We are able to show our readers this month the reproduction of a car which is not new, but which has a valuable record of good service behind it—one which has successfully met the service test. The Woodward Iron Company Railroad uses these 100-ton cars mounted on two six-wheel trucks, and officials of that road express the utmost satisfaction with their

clear of the center sills and there is ample space between its flanges and the wheels. In fact, the truck has none of the appearance of crowded parts evident in many truck designs. The spread of the wheels is four feet four inches, and the wheel base of the truck is, therefore, eight feet eight inches. Single shoe brakes are used, but the truck permits of

is of the ordinary type of such cars. The equipment of the car is similar to that of the previously mentioned 100-ton car. Its light weight is 45,900 lbs. and its capacity is 140,000 lbs. This brings the ratio of tare to load 32.78 per cent. A line painted horizontally on the side of the car shows where a full load of ore would stand, if the ore ran pretty regularly at 110 lbs. to the cubic foot. On both cars the United States safety appliances are standard.



TYPE OF 100-TON STEEL CAR FOR THE WOODWARD IRON COMPANY.

performance. The Pressed Steel Car Co. of Pittsburgh built them.

The car shown in the first of our illustrations is No. 1914, and Mr. A. H. Woodward, chairman of the company, writing to RAILWAY AND LOCOMOTIVE ENGINEERING, on the subject says: "The 100-ton car, No. 1914, is a sample car and has given excellent service. During the first year it was on our railroad, it handled 11,800 tons of coal with no repairs except air brake hose. These cars are handled in trains of approximately 3,000 tons and at speeds ranging from 20 to 40 miles an hour. We have had them more than four years and they show little sign of wear."

This is certainly a good record, and a glance at the views we give shows them to be strongly built and of a neat and finished appearance. The six-wheel trucks, which carry the car, have been carefully designed. The boxes show a good deal of flexibility. That is, their up and down and rocking motion has been adequately provided for. Each box has a wide top but the weight of the car reaches it through a casting, and between this casting and the top of the box there is interposed a single roller lying parallel to the brass. The casting, on top of this roller, supports two double coil springs upon which the frame rests. Thus the weight on each box is concentrated on a roller pin and this again distributes the weight evenly to the box. The box and jaws are well ribbed to add strength and endurance to the design.

The bolster of the truck is a heavy deep casting, with sunken center so as to be

the use of the clasp brake if so desired. The truck is composed principally of pressed steel shapes and is compact and low, so that the car body is kept down to as low a level as can be.

The capacity of the car is 200,000 lbs., but the load limit is permissibly ten tons higher than this. In volume, the cubic capacity of the car is 3,614 cu. ft., and the Pressed Steel Car Company's weight, when new, was 75,300 lbs. This brings the ratio of tare to paying load to about one-twenty-sixth, or about 37 per cent.



TYPE OF 70-TON STEEL GONDOLA FOR THE WOODWARD IRON COMPANY.

This is all the dead weight the engine is compelled to haul, while 63 per cent. is revenue-yielding load. The car is stencilled to show its equipment; Sessions draw gear, Farlow attachments, metal brake beams and Westinghouse K-2 triple valves.

The 70-ton steel high-side hopper gondola, also built by the Pressed Steel Car Company, and used by this railroad,

## Improvements on the Canadian Pacific.

The Canadian Pacific Railway's programme of improvements at St. John, New Brunswick, which has already been entered upon, calls for an additional track-age space sufficient for 350 cars in the west side freight yard. This will bring the total yard accommodation up to 1,850 cars. All light rails now in the yard will be replaced by heavier metals, a new coal-ing plant will be erected, a 20,000,000 gallon fresh water tank installed, and the capacities of the sidings between St. John and Montreal increased.

## The Reason for Railroads.

Mr. Gordon Campbeil, who was a delegate to the recent convention of the American Electric Railway Association, speaking on the reason for railroads, said that the railroads were brought into existence on account of the lack of a surface suitable for a vehicle to carry sufficient people fast enough.

Following them, less than thirty years ago, the electric railway came into

existence, and has also performed its functions, and developed its wonderful system of railways in all centers of population, and inter-connecting these centers and ramifying out from these cities through the adjoining country. Hence the wonderful expansion which they have enabled the cities to enjoy and the tremendous increase in the value of properties.

# Railway Engineering

A Practical Journal of Motive Power, Rolling Stock and Appliances.

Published Monthly by

**ANGUS SINCLAIR CO.**

114 Liberty St., New York.

Telephone, 746 Rector.

Cable Address, "Locong," N. Y.  
Glasgow, "Locoauto."

**Business Department:**

ANGUS SINCLAIR, D. E., Prest. and Treas.  
JAMES KENNEDY, Vice-Prest.  
HARRY A. KENNEY, Secy. and Gen. Mgr.

**Editorial Department:**

ANGUS SINCLAIR, D. E., Editor.  
JAMES KENNEDY, Managing Editor.  
GEORGE S. HODGINS, Associate Editor.  
GEO. W. KIEHM, Associate Editor.

**London Representative:**

THE LOCOMOTIVE PUBLISHING CO., Ltd.,  
8 Amen Corner, Paternoster Row, London, E. C.

**Glasgow Representative:**

A. F. SINCLAIR, 15 Manor Road, Bellahouston,  
Glasgow.

**SUBSCRIPTION PRICE**

\$2.00 per year, \$1.00 for six months, postage paid in the United States, Canada and Mexico. For other parts of the world, \$2.50, or ten shillings. Single copies, 20 cents. Remit by Express Money Order, Draft, Post Office Order or Registered Letter.

Mailing address can be changed as often as necessary—always give old and new address, and if you subscribe in a club, state the name of the agent.

Please give prompt notice when your paper fails to reach you regularly.

Entered at the Post Office, New York, as Second-class Mail Matter.

## The Psychology of the Stop Signal.

How many of us are cognizant of what we call "lapses" in our own thought and behavior? The lapses do not occur all the time and they are not habitual, but when they do happen we notice them. A great many of our acts are what scientific men call "semi-reflex." We would call them more or less automatic.

A man who habitually smokes a pipe, if given a cigar will put up his hand to remove the cigar from his mouth with the grasp of a man expecting a pipe. We forget to mail a letter given by our wife, not because we do not pay attention to her expressed desire for prompt attention, but because, being so sure we will not forget, we permit the idea to be readily crowded out of the realm of consciousness.

The "run" on a stable and solvent bank, originating in a vague rumor, is an example of what the scientific man would speak of as "mob psychology." It is practically the stampede of a herd of animals, and cannot be dignified by any phrase implying the exercise of judgment or thought. There is no rational basis for the illogical action. The suggestion of one frightened or even timorous man, is communicated to others and results in the heedless action of the many. No theater ever burned down so fast that those inside might not have made a safe and speedy exit. It was the rush, by which each struggled to be first out, that brought disaster.

There is a clearly defined reason for

this precipitate action and for the semi-reflex or almost automatic behavior of men, in certain circumstances. The vagaries of sight and the strange interpretations of facts presented to the mind through the senses, have been obvious to railroad men and others for a long time. The many automobile accidents at railway crossings, are but cases in point. Examples are not wanting where a motor car has not been ploughed off the track by an onrushing locomotive, but has collided with the centre and even the rear of the moving train.

It is not possible to ignore such facts, if one seriously desires an adequate reason for the phenomenon. In another column we have endeavored to give our readers such facts concerning railroad operation as we have been able to gather from this standpoint and to show what part, in solving the problem, the stop signal plays in connection with the ordinary automatic signals which have been brought to a high state of efficiency by the regular signal companies in their responsible work of equipping our railways with safety appliances which should be the means of guaranteeing safety to all who travel. It is when the reaction of the signal on the responsible man comes in for analysis that the fault is generally found to be in the man himself rather than in the mechanism.

## Worn Railroad Material.

There is, perhaps, no material that has already served its purpose as valuable as railroad material. It has been misnamed scrap. In the hurry and bustle of railroad service it has been much overlooked. It is gradually attracting attention. It may not be generally known that railroads in America make about forty dollars worth of miscellaneous worn material each year for each mile of road operated. This estimate does not include car wheels, old locomotives, worn rails, structural steel and brass, which, as a rule, have been made the most of under any condition. It would be interesting indeed, were it possible, to set before the mind's eye the large losses that have been needlessly sustained by many railroad companies that could ill afford any loss by the unthinking neglect of the worn material. It seemed in many instances to be left to take care of itself. Sometimes it was everybody's business, and, of course, became nobody's business. A class of middlemen grew up and grew fat on this wastage.

Eventually the Railway Storekeeper's Association took up the matter energetically with the result that a complete classification of the worn material on railroads was made. Ninety-eight separate headings were made, and a few of the leading railroads made a fair trial of the plans suggested, and the first discovery

made was that the discarded material contained 40 per cent of serviceable articles that were returned to the storekeeper's department, almost as good as new. When this became fully known the percentage rapidly dropped to about 6 per cent.

This was not all. The sorting and classifying of the worn material raised its value from two to four dollars per ton. In every instance where an attempt has been made a good saving or profit has been made, and the inevitable tendency has been to transfer the entire matter into the storekeeper's department. It would seem at first glance that the mechanical department would be the best suited for the work, but it has been found by experience that the work requires special training and continued service, and the intermittent work of mechanical constructing and repair men has been found to have a disturbing influence on their own special field of industrial activity, and the results are decidedly more profitable when the work of reclamation and classification is persistently pursued by special men thoroughly trained to a special calling that is growing in importance as it is being better understood.

## Preventing Hot Boxes.

Reports from the New York, New Haven and Hartford Railroad Company show very gratifying results in regard to the strict inspection of cars, journals and journal bearings. During one week last month 18 hot boxes on passenger cars were reported on the entire road, whereas on the corresponding week last year there were 50 reported. Exceptional efforts have been made to reduce the total number to a minimum. Special care is taken in preparing the packing. The waste is soaked for 48 hours in specially prepared oil, and allowed to drain for 48 hours to remove all excess oil, and packed in the journal box in three distinct parts, the first being a roll packed at the back of the box to prevent dust from entering the box from the rear, and to keep the second or center packing in position. The second packing supplies the oil, and is placed in the box fairly loose. The third packing is a roll that is placed in the front of the box to keep the second packing in place and to prevent dust from reaching the journal.

It is incumbent on the train crew to utilize every opportunity to see that no smoke is coming from any of the boxes. Every box is inspected at destination and those unduly warm are marked with chalk indicating that the journal requires attention. The labor entailed is a considerable added item on the New Haven road, but with 2,500 passenger cars running an average of 96 miles per day with an average as low as 3 or 4 hot boxes each 24 hours, the wisdom of the New Haven's policy is made evident.

### Congress and the Railways.

An interesting pamphlet has been issued by the Railway Business Association submitting concrete proposals to the joint committee of Congress for the correction of defects in railway regulation. The hearings of the committee have been set to begin on November 20. Business men are urged to impress upon senators and representatives that national prosperity demands energetic and prompt measures affecting railways. The increase in operating expenses compelled by the eight-hour law accentuates the necessity for legislation to bring regulation into proper relation with the facts of the business as they exist. It is a well known fact that improvement of existing railways and construction of new lines has been retarded, and the time has come when supervision over rates should be made federal by statute, and what is permitted in one State and forbidden in another should no longer continue, as test cases that have been carried to the highest court have established the supremacy of the national Government over whatever factors may influence interstate commerce. The belief of investors that governmental influences will keep railway earnings too low has, in many instances, diverted capital into other channels. It is only natural that there should be an assurance that railway earnings will not be held down below the danger line, and to this end the Interstate Commerce Commission should have power to fix minimum as well as maximum rates and establish such rate systems as will yield the roads sufficient income to perform not only adequate service but to attract investments for improvements and extensions. In hampering the expansion of the railways the Government has hindered the natural development of the resources of the country.

### Fatalities at Railroad Crossings.

The Pennsylvania Railroad has instituted a special enquiry as to why automobile drivers, with motor cars equipped with efficient and powerful brakes, should collide with moving trains at level crossings. The railroad states that in the first eight months of the present year, 13 persons lost their lives and 104 were injured at grade crossings on the Pennsylvania Railroad, under circumstances, the very nature of which, proved the total disregard of caution, and in many cases the willful running of risks.

A large proportion of the total accidents occurred to automobilists. The drivers of 23 motor cars smashed their machines into the sides of trains when the trains were actually part way over the crossing. Four lives were lost in this way and 51 persons were injured. Six motorcycles, two bicycles, and four horse-drawn vehicles were similarly driven into the

sides of trains, causing the deaths of two persons and injury of 14. One trolley car was run against a train at a crossing, but only a single person was hurt.

This gives the thoughtful man pause. The vehicles were not first on the track and ploughed off by the oncoming locomotive. The possession of the road, occupied by a train, was disputed by the vehicle driven ahead with no fragment of hope of getting across. To say that the automobile ran away or could not be stopped in time, is to add to the delinquency of the driver, and does not advance the search for adequate means of safeguarding the occupants of the machine. These men cannot be reasoned with, they do not heed a warning, and they court death it would seem, with eager pertinacity, worthy of a better cause. They have to be protected against themselves. The subway crossing is so far the only means known.

In connection with any inquiry a railway might undertake, the psychological conditions involved should be carefully examined. There is some reason, not yet fully known to us why men, apparently in possession of their faculties, act as if under a spell and cast reason and reflection to the winds. The real reason for the disregard of any signal, caution or stop, is psychological, whether it be an engineman passing a railway signal, or a chauffeur dashing past a warning light. There is no escape from this conclusion, and the scope and object of any enquiry on these lines should be to ascertain the mental condition which produces such deplorable results. A man acting under impulse or the results of suggestion is not a free agent, and though the compelling force which he blindly seeks to obey is not visible to us, it is there nevertheless, and its presence must be reckoned with. We have, in dealing with man as a machine, assumed that he is guided by reason, when the evidence placed daily before us refutes the assumption and shows us that it does not stand on fact. Our analysis of the machine, man, has left out of view the subtle chemistry of the mind, and though we are sure that transformations and reactions take place there as surely as acid acts on zinc, we have hitherto made no adequate effort to face the fact, and ascertain the cause. It is our duty to look for it.

### Switching Locomotives Adapted to Their Work.

The yard engine question is now becoming a live issue on more than one of our large railway systems. In former days an engine which became unsuitable for road service was put into the yard with little or no thought of its fitness for doing the work there in

anything approaching economy or even satisfaction. The modern and more scientific view takes cognizance of the fact that yard engines can be operated, and not simply "worked," as formerly, and there is a great difference between these ideas.

The whole later-day conception of the matter lifts this service to the high plane on which freight and passenger work has been placed by tests, trials and the scientific analysis of results. Quick yard work has become important as tonnage and speeds have increased. The more economical and rational working of yard engines has actually tended to reduce the number required at any one point.

In an article appearing in another column of this issue three types of yard engine are referred to. There is the terminal yard engine, usually a six-wheeler; the transfer yard engine, often an eight-wheeler, and the hump yard engine, of heavy type, approaching and possibly reaching Mallet engine dimensions.

The proportions as far as tractive effort is concerned and the utility of these types have been deduced from some carefully conducted tests made on, at least, two of our leading railroads. It is not hearsay nor theory, but the scientific records of actual performance which forms the basis of the modern view of switching service. It is a live subject all round, and we commend it to the consideration of railway men who are concerned in this and similar problems.

### Valve Setting.

The older class of railroad engineers and machinists nearly all believe that there was great merit in having locomotive valves set with considerable lead. This was said to be necessary to make the engine run smoothly. When this practice was in vogue valve setters frequently fell into the error of giving the valves so much lead that the engines worked against piston pressure to a most injurious extent. At one time it was standard practice to set locomotive valves with  $\frac{1}{8}$ -in. lead in full gear. On some roads 3-16 in. became common, but the fact slowly worked into the minds of locomotive mechanics that large lead did not promote smooth engine operation. A movement to reduce valve lead then began, and it went on till line and line became popular and continues to be the practice today. The common practice of throttling the steam had much to do with the necessity for valve lead, but that practice is now falling out of fashion. The advent of newer forms of locomotive valve gear has also played an important part in valve setting.

# Pacific Type of Locomotive for the Central of Georgia Railroad

Kind of Service Demanded—Engine Designed to Suit Conditions—The Gaines Furnace—Ragonnet Reverse Gear—Result of Test of Three Engines

Recently the Lima Locomotive Corporation of Lima, O., have been called upon to supply some locomotives of the Pacific, or 4-6-2 type, to the Central of Georgia Railroad. Care has been taken by Mr. F. F. Gaines, the Superintendent of Motive Power of this road, in the design and construction of these engines, so that not only the requirements for serviceable engines may be secured, but the local conditions of the division where each operates has received particular attention. The local conditions on any railroad and frequently different divisions of the same railroad require special designs of power to obtain the maximum service and economy.

The Central of Georgia has a service peculiar to itself, in that the divisions are long, and on account of distances between cities and towns the traffic does

approximately fifty miles an hour when in operation between stops. Before the advent of the steel cars, and before increased traffic had developed, a 2-6-0 type of engine was used, with tractive power of 28,008 lbs. As business increased and cars became heavier, a 2-6-2 engine was used, with a tractive effort of 30,870 lbs. The increased boiler capacity relieved the situation temporarily, but again the cars became heavier and more of them had to be hauled and the light 2-6-2 could barely make the schedule.

Meanwhile a study was made to determine the most suitable boiler design to give maximum power with minimum weight. It was known that some years ago experiments were made in France which showed conclusively that the best length of flue for a given diameter, for

as compared with a straight flue sheet.

With this data, it seemed desirable to have a combustion chamber to keep the flue lengths down to proper proportions, a long flameway for gases, as much firebox and combustion chamber heating surface as possible, and the introduction of superheated air to mix with and consume unburned gases before they entered the flues where, of course, all combustion ceases.

Due to low water, a 2-8-0 type of engine had blown down the crown sheet and distorted the whole back head. It was decided that, as the type of engine was notoriously lacking in steaming capacity, and was very extravagant with fuel, to rebuild the back head and include a combustion chamber, hot air ducts and liberal grate area. The engine which failed in this way was built in

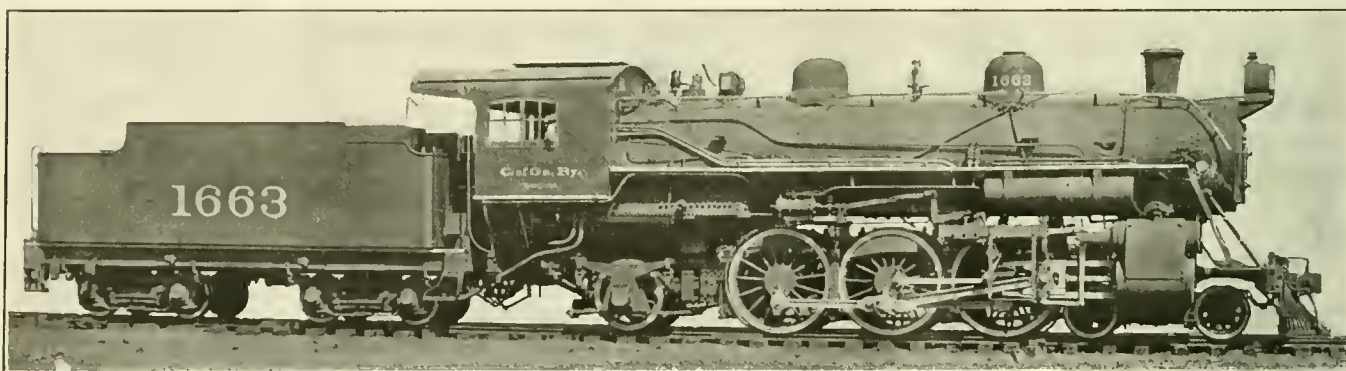

PACIFIC OR 4-6-2 TYPE ENGINE FOR THE CENTRAL OF GEORGIA RAILROAD.

F. F. Gaines, Supt. Motive Power.

Lima Loco. Corporation, Builders.

not warrant a local service in addition to a through service; so that, on a majority of divisions, the service is combined. As an illustration, Savannah to Macon is 190.8 miles. There are eighteen regular stops, five of these being of at least five minutes' duration, on account of junction points and the transferring of passengers, mail and express. There is one coal chute stop, three crossing stops and twenty-two flag stops, making a possible total of forty-four. As a rule, few of the flag stops are omitted. The time card for this distance allows six hours and fifteen minutes, a schedule of approximately 30.3 miles an hour. The trains are of steel construction, except the local sleepers, and a maximum train of fourteen cars is quite frequent.

These conditions require an engine capable of quick acceleration and good steaming capacity, to allow of approxi-

maximum results, was a length about 110 times the internal diameter of the flue.

Familiarity with the Wooten combustion chamber also convinced the mechanical department of the Central of Georgia Railroad that a long flame way, before hot gases entered flues and firebox heating surface, were very important factors. There were objections to the Wooten type of combustion chamber, in that it was necessary on occasion to kill the fire, allow engine to cool and have a man get into the chamber to remove accumulated sparks. Where muddy or scaling water was used, a large water space around the chamber was necessary. On account of joining the roof sheet, inside the throat sheet, and barrel of chamber, three thicknesses of metal were exposed to hot gases, and this caused more or less trouble due to leaking. The water space cut out a large number of possible flues,

1901, and was a 21 x 32-in. engine, with a tractive power of 43,619 lbs. The grate area was 33.73 sq. ft., and the total heating surface was 3,022.29 sq. ft. This engine was rebuilt with several important modifications.

The rebuilt engine more than justified the foregoing theories. It developed the same tractive power as formerly, but the grate area was increased to 56.36 sq. ft., while the total heating surface was practically as it was before, being actually 2,953.36 sq. ft., or 68.93 sq. ft. smaller, with a much larger grate area. A test was made on the Southwestern division, using steel coal cars loaded with company coal for the train throughout the tests. A similar engine as originally built, the rebuilt engine (1014) and a wide firebox consolidation of greater heating surface and grate area were included in the tests. These tests estab-

lished definitely the value of the combustion chamber with hot air inlets, and a spark hopper to clean it out when necessary.

Shortly after these tests it was evident that the advent of the steel car and increased service demanded a more powerful engine. A 2-6-2 with combustion chamber was designed and five were purchased. Their superiority was at once evident, and for the character of service outlined have proved most satisfactory. Another lot of four was acquired in 1913, and four more in 1916.

On the Macon division the traffic was unbalanced, an engine being required to handle a light train in one direction and a heavy through train coming back. The question as to using the heavy combustion chamber locomotive on the light train arose in connection with the matter of fuel economy.

A series of tests were run to definitely establish this question of fuel economy, the results being shown in the table given near the end of this article. This established a fuel economy for the heavy 2-6-2 engine over the light 2-6-2 of about 30 per cent. It will be seen that this was for the average of both trains. If train No. 3 only were considered a much better showing would have been made.

Various railroads are adopting this type of firebox, and there are, excluding the Central of Georgia, over two hundred in use. It has, in addition to the advantages described, that of allowing part or the whole of the firebox to be placed over drivers. This is permissible, as the firebox may be made shallow, with a long combustion chamber. The bridge wall with air ducts protects the flues from becoming stopped up, as would be the case with a shallow box without the wall, and too shallow for a regular arch.

It may here be admissible to say a word about the Gaines Locomotive Furnace. It consists essentially of a fire brick bridge wall extending across the firebox, thus forming a combustion chamber between the wall and flue sheet, the tubes being shortened and the firebox lengthened sufficiently to admit of this application, while the grate remains practically normal. The bridge wall is carried by a casting extending across the firebox and secured to the mud ring at each side by studs. This casting also supports the grate frames and the buck stays in the rear, which prevent the wall from toppling. The floor of the combustion chamber is made of cast or wrought iron plates, protected with fire brick to prevent their burning out, and in order to hold the cinder accumulation in the combustion chamber, a spark hopper is provided in the center, the floor being given sufficient pitch to cause the cinders to drop out when the hopper is opened.

The bridge wall is built up of special

fire brick of such size as can be easily handled, and in the bricks are cored for air passages matching the openings in the carrier casting.

When the locomotive is operating the wall becomes white hot, with the result that the outside air, being brought through the air ducts, is heated up before being discharged into the firebox.

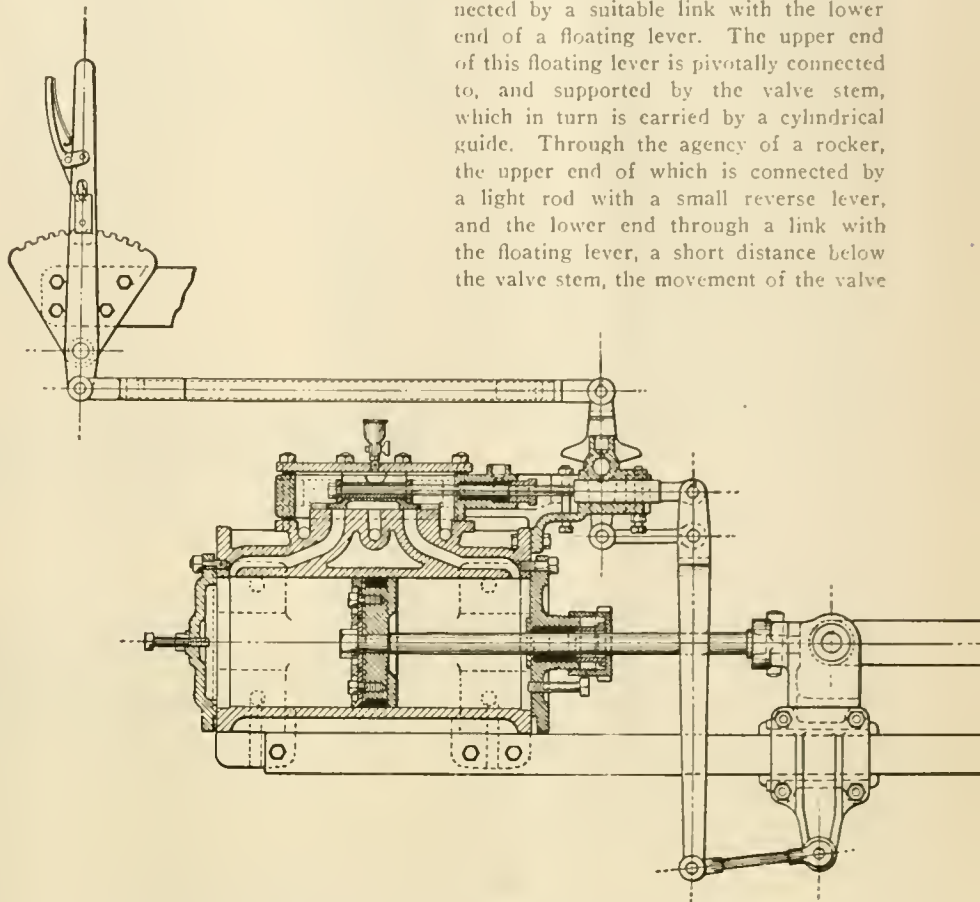

OUTLINE DRAWING OF THE RAGONNET REVERSING GEAR.

As it issues from the ducts near the top of the bridge wall the heated air comes in contact with and mixes in the combustible gases that pass over the top of the wall. Combustion begins the instant the air comes in contact with the gases, and the reaction continues until the gases are all burned or the flames are extinguished on entering the tubes.

Aside from its aid to combustion, the wall also offers protection to the flues. The combustion chamber is made thoroughly air tight, so that it is impossible for cold air to reach the flues through a hole in the fire or through an open fire door. Air entering through either of these places is forced to pass over the wall and come in contact with the flames, hot gases and incandescent brick, thereby being heated before reaching the flues.

The fact that arches of the "Security" type were giving good service and possessed many advantages was not to be lost sight of, and after some trials the Gaines Combustion Chamber and Security Arch were combined as the Gaines Locomotive Furnace.

Among the other devices used on these engines with satisfaction is the Ragonnet power reverse gear. The gear is operated by air, and its movement is controlled by a D-slide valve arranged for outside admission. The piston-rod of the reverse mechanism is connected to a cross-head, which is coupled to the reverse shaft by a reach-rod. The cross-head arm is connected by a suitable link with the lower end of a floating lever. The upper end of this floating lever is pivotally connected to, and supported by the valve stem, which in turn is carried by a cylindrical guide. Through the agency of a rocker, the upper end of which is connected by a light rod with a small reverse lever, and the lower end through a link with the floating lever, a short distance below the valve stem, the movement of the valve

is controlled by the engineer in the cab.

The small reverse lever is locked in any desired position by an ordinary toothed quadrant. Assuming the lever to be in mid position and the valve normally covering both ports; when the lever is moved into forward gear the floating lever swings about its lower end as a fulcrum, and the slide valve is moved to the right, admitting air to the left-hand end of the cylinder. The piston now moves to the right, and the floating lever, pivoting about its intermediate, or reverse-lever connection, returns the valve to its central position unless the progressive movement of the reverse lever is continued. When the lever is moved to a desired position the piston moves in the proper direction until the valve gear reaches a corresponding point, then the valve is automatically returned to its central, or lapped position.

The exhaust, or inside lap of the valve is materially greater than the outside lap, so that the air is held on both sides of the piston at the same time. The mechanism cannot creep in the cylinder. The

loss of air, when holding the valve gear in a fixed position, is practically nothing. The man on the engine is relieved from much physical exertion.

In concluding this article, we give a table kindly supplied by Mr. Gaines, which shows the results of some interesting and instructive tests, and the matter here presented can be relied on as accurate when we remember the source from which it emanates. In the summary, engine No. 1014, having the smallest heating surface of the three engines, when supplied with a new firebox, combustion chamber with hollow brick, ran 15.38 miles to a ton of coal. Engine No. 1012, of same class as the one above, but with original boiler unchanged, but provided with a brick arch and larger heating surface, yet ran on the average 9.54 miles to the ton of coal. Engine No. 1716, with brick arch and the largest total heating surface of the three, yet fell below the first mentioned engine and covered 13.14 miles for one ton of coal.

The dimensions of No. 1663 are as follows:

Length of driving wheel base, 12 ft. 0 ins.; total wheel base of engine, 31 ft. 6 ins.; total wheel base of engine and tender, 64 ft. 5 ins.; diameter of drivers, centers, 62 ins.; size of driving journals, 10 ins. x 12 ins.; diameter of front engine truck wheels, 33½ ins.; size of front engine truck journals, 6 ins. x 12 ins.; diameter of trailing wheels, centers, 41 ins.; size of trailing wheel journals, 8 x 14 ins.; diameter of tender wheels, 33 ins.; size of tender journals, 5½ ins. x 10 ins.; size of cylinders, 23 ins. x 28 ins.; type of valve,

single ported, balanced piston; with travel of 6½ ins.; steam lap, 1½ ins.; valve gear, Walschaerts; Gaines' Combustion Chamber; Schmidt Type "A" Superheater; outside diameter of boiler at smallest ring, 70 ins.; number of flues, 194 two-inch, and 28 five and three-eighths; outside diameter; length of flues over fluesheet, 18 ft.; length of fire-box between sheets, 11 ft.; width of fire-box between sheets, 7 ft.; grate (active), 7 ft.-2¾ ins. x 7 ft.; grate area (active), 50.75 sq. ft.; heating surface of fire-box, 163 sq. ft.; external heating surface of

flues, 2588 sq. ft.; super-heat heating surface, 605 sq. ft.; total equivalent heating surface, 3658 sq. ft.; steam pressure 190 lbs.; water capacity of tender, 7,500 gals.; coal capacity of tender, 13 tons; weight on front truck in working order, about 44,800 lbs.; weight on drivers, in working order, about 132,200 lbs.; weight on trailer, in working order, about 45,800 lbs.; weight of engine, in working order, about 222,880 lbs.; weight of tender, loaded, about 156,300 lbs.; weight of engine and tender, loaded, about 379,100 lbs.

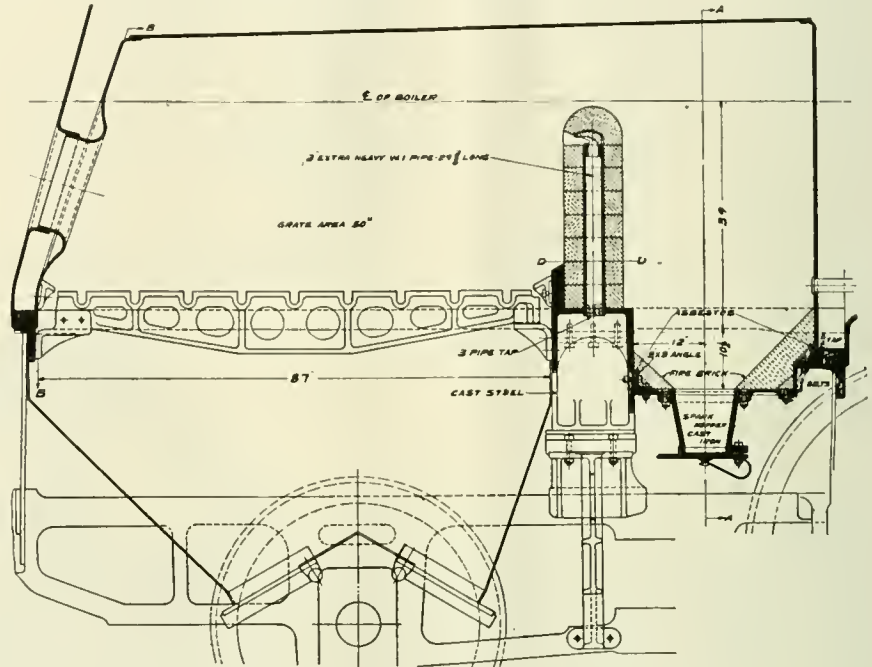

SECTIONAL VIEW OF THE GAINS LOCOMOTIVE FURNACE.

CENTRAL OF GEORGIA RAILWAY COMPANY.

ACCOUNTING DEPARTMENT.

ENGINE TEST—SOUTHWESTERN DIVISION—FREIGHT SERVICE—MACON AND COLUMBUS, 100 MILES.

Same eighteen carloads of coal handled in each test. Same engineer and fireman each test. Weight of train 1,286.25 tons—128,625 tons one mile gross weight, per trip each way.

Engine Number	Train Number	Date	Actual Time Consumed	Stops		Pounds Coal Consumed			Pounds Water Evaporated		Miles Run to One Ton of Coal	Tons Coal used in excess, based on Engine 1014 as unit of comparison	Relative efficiency based on coal consumption per mile
				No.	Time Consumed	Total	Per 1,000 Ton Miles	Per Hour	Total	Per Pound of Coal			
*1014	Extra	1/13/11	6 hr. 34 m.	6	1 hr. 4 m.	11,950	93	1,820	96,800	8.10	16.74	.....	.....
		2/36	1/14/11	6 hr. 42 m.	8	1 hr. 33 m.	13,350	104	1,991	109,000	8.16	14.98	.....
	1014	3/37	1/16/11	6 hr. 12 m.	7	49 m.	12,450	97	2,008	105,750	8.49	16.08	.....
1/36		1/17/11	6 hr. 39 m.	7	1 hr. 12 m.	14,250	111	2,143	109,800	7.71	14.04	.....	.....
			26 hr. 7 m.	..	4 hr. 38 m.	52,000	101	1,991	421,350	8.10	15.38	.....	100.00
†1012	Extra	1/18/11	7 hr. 12 m.	5	57 m.	20,400	159	2,833	121,458	5.95	9.80	.....	.....
		1/19/11	8 hr. 4 m.	5	1 hr. 16 m.	21,900	170	2,715	124,887	5.70	9.13	.....	.....
1012	Extra	1/20/11	6 hr. 43 m.	5	45 m.	19,087	148	2,841	113,095	5.93	10.48	.....	.....
		2/36	1/21/11	7 hr. 20 m.	8	1 hr. 43 m.	22,500	175	3,068	121,883	5.42	8.89	.....
			29 hr. 17 m.	..	4 hr. 41 m.	83,887	163	2,865	481,323	5.74	9.54	15.94	61.96
§1716	Extra	1/23/11	8 hr.	9	2 hr. 33 m.	15,000	117	1,875	110,400	7.36	13.33	.....	.....
		1/36	1/24/11	7 hr. 24 m.	10	1 hr. 41 m.	16,500	128	2,230	120,000	7.27	11.43	.....
1716	Extra	1/25/11	6 hr. 50 m.	9	1 hr. 20 m.	13,800	107	2,080	102,801	7.45	14.49	.....	.....
		1/36	1/26/11	7 hr. 28 m.	12	1 hr. 42 m.	15,600	121	2,089	117,166	7.51	12.82	.....
			29 hr. 42 m.	..	7 hr. 16 m.	60,900	118	2,050	450,367	7.39	13.14	4.45	85.58

ANALYSIS OF FUEL.

Per cent. Moisture	1.39
Per cent. Volatile Combustible Matter	30.56
Per cent. Fixed Carbon	55.11
Per cent. Ash	12.94

Total	100.00
Per cent. Sulphur	1.55

B. T. U. per 1 lb. dry coal (Mahler Atwater calorimeter)...13,179  
 B. T. U. per 1 lb. actual coal.....12,996

\*Engine 1014—21" x 32" Cooke Consolidation—with new firebox and combustion chamber, with hollow brick wall and provision for mixing hot air with burning gases. Total heating surface 2,987.33 sq. ft.

†Engine 1012—Same class engine as 1014, but with original boiler unchanged and brick arch. Total heating surface 3,022.29 sq. ft.

§Engine 1716—22" x 30" Baldwin Consolidation—brick arch. Total heating surface 3,230 sq. ft.



# Air Brake Department

## Triple Valve Maintenance—Cost of Operating Air Compressors— The Portable Test Truck

The April and May issues of this magazine contained articles dealing with the cleaning, repairing and lubricating of triple valves and other car brake operating valves, in which the writer attempted to emphasize the importance of accurate repair work and a sensible method of lubrication for car brake operating valves. A limit is being placed upon the amount of lubrication that is permitted in a brake cylinder, and repairmen are beginning to understand that brake cylinder leakage is being observed in pounds per minute from an air gage, and there is no question but that a marked improvement is being made in all of the branches of air brake repair work and inspection, but there is still room for further advancement, and the most immediate demand is for an improvement in triple valve cleaning, repair work and lubrication.

Regardless as to what has been done in the past or what we tell the members of air brake associations or air brake clubs, what we have done in the way of improving air brake conditions, the undesired quick action, the stuck brake and the slid flat wheel are still with us, and these three formidable obstacles in the way of the attainment of 100% efficiency in train brake operation may always be with us, as there is always a possibility of a stuck brake or the slid flat wheel originating from low steam pressure on the locomotive boiler or to a loss of the excess pressure in the main reservoir.

If there is any material reduction in the number of stuck brakes and cases of undesired quick action there is sure to be a corresponding decrease in the number of slid flat wheels, and as this is a very broad subject, it is desired to touch upon it from but a single phase, a consideration of these disorders from a viewpoint of triple valve or car brake operating valve condition.

In passenger service we instruct an engineer to make no light brake applications, and if a 5 lb. brake pipe reduction stops the train at the desired point, 6 or 8 lbs. more reduction in brake pipe pressure is to be made after the train stops and *before* an attempt to release is to be made. This, so far as possible, to insure a satisfactory release of brakes or at least to facilitate a release of brakes, in fact one large railroad system in particular insists upon no less than a total of 15 lbs. brake pipe reduction before an attempt is to be made to release brakes.

From this we sometimes lead an engineer to believe that it is the light brake pipe reduction that sticks the brake. Occasionally we are able to make ourselves imagine that such is the case and can take an air brake recording gauge chart and prove to the engineer that the cause of the seventh or eighth brake in a 12 or 14-car train sticking was due to too light total brake pipe reductions, but it will be necessary to ignore the fact that the brake valve manipulation was obviously good enough to release all of the other brakes in the train.

The fact of the matter is that this is largely a case of triple valve maintenance as triple valves can be found in almost any train of cars that require from five to eight pounds or more differential in pressure before a release of brakes can be effected, therefore the instructions are sound but the real cause of the sticking is ignored.

In the articles previously mentioned an effort was made to point out just why a moist substance as a lubricant for triple valves or any other car brake operating valves must be dispensed and why the dirt collector would be the logical place for the use of oil or grease and if valves are to be maintained in a condition to remain in service for a specified length of time and have no part in the responsibility for the stuck brake, the slid flat wheel and the undesired quick action, there are certain absolute requirements that must be met in the repair work, cleaning and lubrication.

The triple valve must be cleaned with some substance that will remove all of the dirt and oily matter from all of the parts.

Thereafter the piston and piston bushing should be given a bath in some substance that will evaporate and leave all of the parts dry.

Kerosene will do for the former and gasoline for the latter.

The repair work must be accurate enough for the triple valve to pass all of the specified tests dry or without any lubricant whatever.

The triple valve piston should fit the bushing.

A piston that is from 1/64" to 1/32" smaller than the bore or inside diameter of the bushing cannot be considered a fit.

If the triple valve is lubricated at all it should be with a dry substance.

No attempt should be made to fit packing rings in triple valves in the average repair room. It is absurd to suppose that a ring can be worn out without wearing

the bushing or that a packing ring can be fitted to a worn piston bushing.

Because a triple valve can be made to pass all of the tests specified on the test racks, it does not prove that the triple valve is fit for service, and for these reasons the repair work should be done largely by the manufacturers or in shops where the facilities for doing the work approximate those of the manufacturers.

A triple valve that will not give two or three years' service after being repaired is no good. There is something radically wrong with the repair work done on the valve. By this it is meant average conditions in railroad service. In fact, if all of the rest of the car brake apparatus is correctly maintained, there should be no necessity of again taking the triple valve apart within two or three years from the time it is repaired and applied to the car.

It is, however, the character of the lubricant used that frequently creates the impression that valves are not being properly cared for in the repair room and it is sometimes difficult to convince anyone that foreign matter enters the valves after they are placed in service, and those most difficult to convince usually take the stand that triple valves should be cleaned and lubricated at least once every 30 or 60 days, and the whole thing leads to such ridiculous suggestions as boiling triple valves in lye, cleaning in paraffine and bathing in salt water and other preparations, and this evidently for the sole purpose of removing the oil and grease, and in turn the same recommendations will permit of the oil and grease being replaced when the movable parts are assembled.

We do not wish to hold any recommendations up to ridicule, but to merely point out some of the inconsistencies and wish to repeat that if foreign matter could be entirely excluded from the triple valves and from the brake system it would never be absolutely necessary to clean a triple valve, but until such time as the entrance of foreign matter can be prevented, we can at least prevent the collection of the foreign matter in those parts of the triple valve where they are most harmful.

The moist lubricant placed in the triple valve piston groove, merely picks up enough dirt to stick the ring in the groove, and if it does not, the chances are that the ring was too loose a fit in the groove in the first place. If a valve, properly lubricated, becomes dry or if the lubrication disappears in three months

time as has been proven, and the valve then remains in service for a year giving good results, there is no logical reason why it cannot be run dry for the entire twelve months instead of nine out of twelve. The writer has never found a dry valve working in undesired quick action unless it was partly obstructed with foreign matter or the dryness was accompanied by some obvious mechanical defect.

We mention this because we believe that the most important improvement that can be made in train brake operation at the present time or with present equipment, is in more accurate triple valve repair work, and in the elimination of moist substances from all parts of the triple valves. By accurate triple valve repair work it is not necessarily meant that it must be done in a railroad shop for the reason that attempts are always made to do this work on an economical basis, saving a few dollars on the cost of repair parts or on what is termed the "shop order," whereas the fact of the matter is that anything that can be saved on the repairing of triple valves is spent on car wheels and damage to other parts of the equipment and frequently a great deal more.

The writer does not believe in doing any triple valve repair work in a railroad shop; does not even believe in cleaning a triple valve in a repair room, or in cleaning them at all if they are properly lubricated when accurately repaired and placed in service. In many instances it would be the most economical policy to remove a triple valve from a car and return it to the manufacturers without ever looking at the inside of it, because as previously stated if the valve will not give two or three years' service without any attention something else besides the triple valve requires attention.

**Cost of Operating Air Compressors.**

We have recently received inquiries concerning the comparative cost of operating the 9½ and 11 and 8½ ins. Cross Compound air compressors, and these questions were relative to the comparative coal consumption under what was stated as average conditions, and the average condition would be something exceedingly difficult to determine. There is a wide variation among the different railroads as to steam and air pressures employed as well as the length of trains, amount of leakage from the brake system, and grade conditions or frequency of applications of the brakes.

Another thing that must be remembered is that the conditions under which an air compressor operates are somewhat peculiar in that there are no brake applications at the time the engine is being worked to its maximum capacity and that when the brake applications are made the engine throttle is shut off and some of

the steam consumed by the air compressors would otherwise be wasted through the safety valves, that is, there is a possibility of such being the case.

Another phase of the situation is that it is impossible to work up any accurate statements for average conditions, since the amount of water that will be evaporated per pound of coal varies widely according to the type of coal used, some coal will evaporate approximately 5 lbs. of water per pound of coal while other grades of coal will evaporate from 10 to 11 lbs. of water per pound of coal.

As a comparison of the amount of steam consumed by the three different types of compressors for doing an equivalent amount of work or delivering an equal number of cubic feet of free air for a specified length of time, when operating against 100 lbs. air pressure with 200 lbs. steam pressure, the 9½-in. compressor consumes approximately 68 lbs. of steam per 100 cubic feet of free

viewpoint of cost of brake pipe leakage, and it certainly emphasizes the importance of the elimination, so far as possible, of brake pipe leakage from a standpoint of economy in coal consumption, saying nothing whatever of the possibilities from improved brake operation.

On a 100-car train, an 8 lb. per minute leakage from the brake pipe is assumed, and with such a train 3,621 lbs. of coal will be consumed during a trip of 12 hours duration through brake pipe leakage alone. From tests made with trains averaging 68 cars, two 11-in. compressors in average condition, it was found that the coal consumed by the compressors was 7,500 lbs. per trip of 115 miles made in 13 hours.

From another point of view, the cost of train pipe leakage in fuel with compound pumps, it was found that this would fluctuate around .00015 cents per car mile, or 15 cents per thousand car miles. On one particular road, the total car mileage,

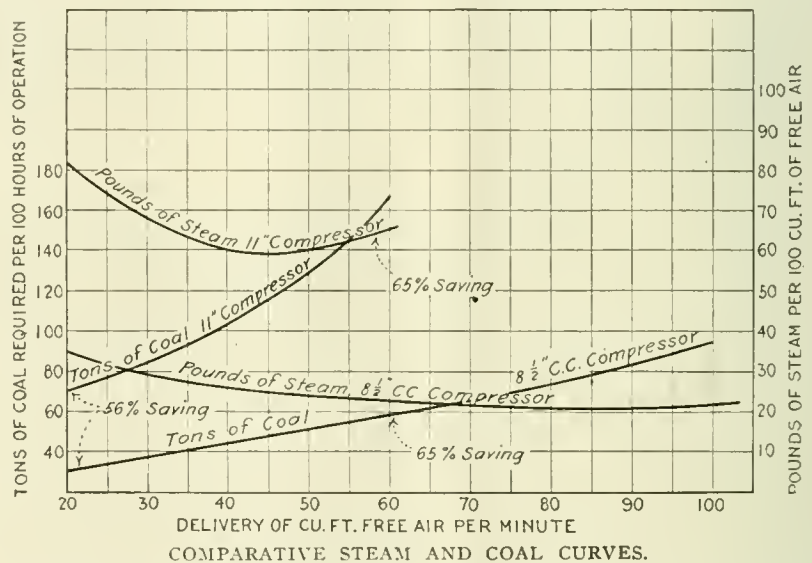

For various rates of air delivery of the 11" x 11" x 12" and the 8½" C. C. compressors at 185 lb. steam pressure and 110 lb. air pressure. Compressor speed controlled by 1¼" governor set at 110 lbs. Coal required computed on the basis of 7 pounds of water evaporated per pound of coal and 1,000 hours continuous service.

Example: At 50 cu. ft. free air per minute 11" compressor uses 129 tons of coal and 8½" C. C. compressor uses 52 tons of coal. 129 - 52 = 77 tons saving. 77/129 = .60 or 60% savings.

air delivered, while the 11-in. compressor 65 lbs. and the 8½-in. cross compound 24 lbs. per hundred cubic feet of free air delivered.

From estimates that have been made covering the actual cost of operation of air compressors in steam railroad service, it appears that the cost of operating the 9½-in. compressor is about 185% more per hundred cubic feet of free air delivered than the 8½-in. compressor. However the cost in dollars and cents would depend upon the various conditions mentioned.

There is a considerable amount of information given in a paper read before the International Railway Fuel Association, at Chicago, Ill., last May, in which the cost of air compressor operation was dealt with, but this was mostly from a

freight, passenger and work train, was 798,607,253 which at 15 cents per thousand car miles means an expenditure of \$119,791 per year to maintain brake pipe leakage.

As a comparative cost of the different compressors in this operation, it was found that for the same amount of work in maintaining brake pipe leakage, the cost with the 11-in. compressor would be \$299,477 per year, and with the 9½-in. compressor the cost would be \$359,373.

The diagram shown here, obtained from tests made by the Engineering Department of the Westinghouse Air Brake Company, shows a comparison of the amount of steam and coal consumed by the 11-in. and 8½-in. for a given amount of work per hour. That is, it is intended to demonstrate the economy in coal con-

sumption that is made possible by the use of the cross compound compressor which uses the steam from the high pressure cylinder into the low pressure cylinder for work before it is exhausted to the atmosphere or rather uses the steam twice as is meant by the expression compounding. With the cross compound air compressor, however, compressed air is also utilized to assist to a certain extent in the operation of the compressor, that is, in the final stage of compression, air compressed from the low pressure air cylinder assists in the operation of the low pressure steam a high pressure air piston.

### The Portable Brake Test Truck.

What we are disposed to term an air brake test, either a road test or a terminal brake test, is a misnomer, or merely an expression and a more discriminating term would be a brake trial, as there is nothing in the nature of a brake test involved in applying and releasing the brakes on a train of cars from a brake valve on the locomotive or from a cut out cock and fittings between the brake pipe of a train of cars and the yard test plant.

What constitutes a brake test that will locate a defective triple valve, that is, a triple valve that will fail in a release test or work in undesired quick action out on the road, is a brake application made at a slower rate of brake pipe reduction than that made by the locomotive brake valves, and a release made with a slow predetermined rate of rise in brake pipe pressure.

The application and release made from the locomotive brake valve is made under the most favorable conditions, with the most rapid permissible rate of brake pipe reduction for the application and with the maximum main reservoir pressure for the release, and both made with the train at rest so that the brake action is not influenced by conditions that are present when the train is in motion, consequently such an application and release is merely an indication of service operation and cannot possibly be construed to indicate any actual condition of the car brake operating valves in the train.

The use of the portable brake test truck makes possible the release test with a previously determined, uniform rate of rise in brake pipe pressure that will locate a triple valve that will fail to release under a somewhat more severe condition than that imposed by the application and release from the locomotive and will locate a car brake operating valve that has a tendency to work in undesired quick action.

It must be admitted that there are other causes for undesired quick action, stuck brakes and slid flat wheels than those emanating from car brake operating valves or the condition of these valves, but it is safe to say that there

will never be an entire freedom from those troubles and very little advancement in that direction until such a time as brakes on trains are being *tested* instead of "*tried*."

If it were possible to succeed in breaking up certain obsolete practices which were established solely through someone conceiving the idea that they were necessary, or because they were necessary or the best known methods five or ten years ago, it would be possible to have a much more efficient brake and considerably less trouble and fewer delays with a smaller force of men than is at present employed on air brake repair work. As an example, the air brake repairman is called upon to remove triple valves from cars for cleaning at periods ranging from two, and three to six months from the time that they are placed in service, and at the same time the only test that is specified is the one after the valve has been cleaned or repaired. Evidently the object of all of this work is to locate, or an effort to locate, valves that might develop some disorder.

Would it be logical to test the valves for symptoms of disorders every day, or every time the car is made up in a train and clean the valves whenever necessary? The writer does not believe that all of our present-day practices are utterly absurd, or that we are not continually improving upon them, but many of those in vogue at the present time will appear ridiculous to the air brake man of the next generation.

How frequently a brake cylinder or triple valve should be cleaned is a matter of secondary consideration, probably best answered by the expression "as often as condition of service may require," and this will depend very largely upon the character of the cleaning, repairing and lubrication, but the brake should be thoroughly tested at least once each week, or preferably a brake test should be made with the brake test truck, every time a train is made up with sufficient time between the test and leaving time of the train, for the necessary repairs to be made.

### Thermostatic Control.

This is a system of automatically maintaining a constant temperature in a passenger car by so arranging the thermostat that it will constantly shut down and open up the valve for supplying steam to the coils, which heat the car. The mechanism of a thermostat is briefly a double diaphragm partly filled with a very volatile liquid. One of these diaphragms is rigidly fixed so that the movement caused by expansion or boiling of the liquid inside the apparatus shall produce the maximum effect on the outer diaphragm. The slight movement thus produced is multiplied by a tongue and

lever, and this multiplied movement is made to effect the opening and closing of the steam valve.

The thermostat can be applied to an electric switch so that the current may be turned on or off automatically by the movement of the diaphragm. The theory of the whole thing is that if an accurate maintenance of temperature had to be effected by individual attention it would necessitate a man sitting with his hand on the throttle and his eye on a thermometer all the time, just as the engineer of a steamship has to "stand by" in rough weather in order to prevent the engine from racing. The extra man with his constant watchfulness is here replaced by a thermostat which responds quickly and accurately to the minutest fluctuation of temperature.

In this way the thermostat does away with hand control. It gives an even and comfortable temperature all the time. Where coils are used it reduces steam consumption by permitting only the required amount used to be admitted to the coils. It tends to keep the pipe pressure down to a minimum. It prevents damage to woodwork, varnish and internal fittings which might be caused by overheating. It keeps the rear cars of a train at the same temperature as those at the front.

When a car, not subject to automatic control, is standing in a yard it is usually overheated because the yardman, not being constantly present, turns on more steam than is actually necessary in order that if the weather grows colder the conditions may be successfully met. The thermostat, on account of its automatic action, maintains the temperature of a car standing in a yard as carefully as it would if the car was on the road and full of passengers.

When a thermostat is applied to an electrically heated car it has the effect of turning on and shutting off the heating current rapidly and frequently, as circumstances may require. It does not require more than one circuit in a car, and also the throttling action which takes place with steam is absent. Electric current is turned full on or full off a great many times owing to changes in temperature conditions, and it thus produces an equable temperature all the time. The standard temperature required by any company may be had by permanently setting the thermostat so that if 70 deg. F. be decided upon by the company, all the cars are heated to that temperature without requiring the judgment of, or individual manipulation by a brakeman. There is thus no "human" variations or opinion as to the reading of the thermometer. The thermostat set at 70 deg. F. will give 70 degs. F., neither more nor less, and this thermostatic control is applicable to a straight steam system or to a vapor system.

# Yard Engine Adaptation to Service

## Worn Out Road Engines Not Suitable for Yard Work—Conditions Considered—Types of Engines Suitable—Results of Tests; Sizes and Dimensions

The subject of the adaptation of yard engines to the service required has not in the past received the attention that it should have received, and the consequence is that the yard engine as an instrument for the economical performance of the work of switching cars, has not, in a general way kept pace with other improvements in railroad service. The former practice—not perhaps wholly abandoned yet—consisted in taking a Mogul or a Consolidation engine which had become unfit for road work and relegating it to the yard, with the dim idea that the engine, not having been scrapped, was still a useful and efficient machine for the less arduous work of switching. How far from accurate this judgment was, and is, now daily becomes more and more apparent.

In a general way, good modern practice

of the road engine draw bar pull. The Pittsburgh & Lake Erie Railroad with a road engine capacity of 44,100 lbs. draw bar pull, uses yard engines of 35,360 lbs., or 80 per cent of the road engine power. The average of these railroads is 67.6 per cent, and while each road has found its own proportion advantageous for its own governing circumstances, it is fair to suppose from 65 to 75 per cent is a fair proportion of road to level-yard power. In the case of the P. & L. E. this type of yard engine with 80 per cent of road engine power does the terminal yard switching and the transfer work as well.

On the first mentioned road the transfer yard engines, which operate over some grades and encounter sharp curves are eight-wheel engines of the following dimensions, Fig. 3. They are equipped with the Gaines locomotive fire brick wall,

doing the terminal switching and the transfer work.

The hump yard engines, used on the first road are of the heavy 0-10-0 type, and have a draw bar pull of 62,500 lbs. This is in excess of the road engine's power, which is only 92.1 per cent. of the hump yard engine capacity. These engines are largely used for transfer work, as well as for pushing trains up grade over the hump into the classification yard. The engines used on this first mentioned road for hump yard service are 108.5 per cent. of the road engine power, or, to put it as above, the road engine is 92.1 per cent. of the hump yard switcher. This engine is shown in Fig. 4 and the road engine is represented in Fig. 5.

The P. & L. E. uses only two types of yard engines, the level yard switcher, which is about 44,100 lbs. draw bar pull,

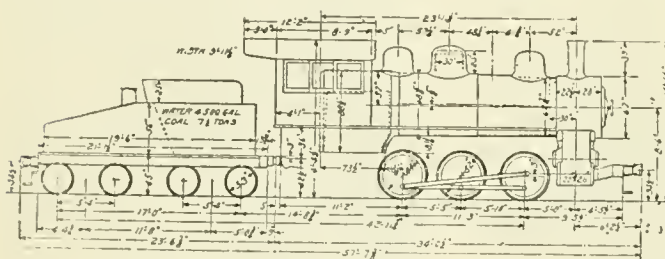

FIG. 1. SIX-WHEEL YARD ENGINE.

Kind of main valve.....Piston 11 in.	Heating surface firebox, incl. arch flues.....142 sq. ft.
Valve travel.....5 1/4 in.	Heating surface total.....2,326 sq. ft.
Kind of valve gear.....Stephenson	Weight on drivers working order.....143,000 lbs.
Firebox length inside.....65 3/8 in.	Weight total of engine.....143,000 lbs.
Firebox width inside.....62 1/4 in.	Weight of tender loaded.....89,000 lbs.
Grate area.....28.2 sq. ft.	Weight of tender empty.....36,500 lbs.
Tubes number.....279	Steam pressure.....180 lbs.
Tubes length over sheets, 15 ft. 0 5/8 in.	Rating.....31.8 per cent.
Tubes diameter outside.....2 in.	
Heating surface tubes...2,184 sq. ft.	

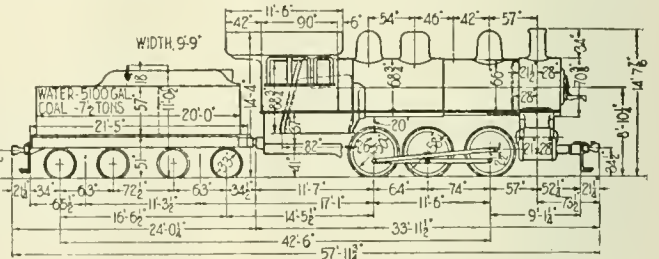

FIG. 2. SIX-WHEEL SWITCHER, STRAIGHT TENDER.

Kind of main valve.....Piston 12 in.	Heating surface firebox, incl. arch flues.....136.9 sq. ft.
Valve travel.....5 1/2 in.	Heating surface total.....2,703.7 sq. ft.
Kind of valve gear.....Stephenson	Weight on drivers working order.....158,000 lbs.
Firebox length inside.....72 3/8 in.	Weight total of engine.....158,000 lbs.
Firebox width inside.....65 1/4 in.	Weight of tender loaded.....103,500 lbs.
Grate area.....32.7 sq. ft.	Weight of tender empty.....46,000 lbs.
Tubes number.....308	Steam pressure.....180 lbs.
Tubes length over sheets.....16 ft.	Rating.....33.7 per cent.
Tubes diameter outside.....2 in.	
Heating surface tubes...2,566.8 sq. ft.	

recognizes three classes of yard engines each with a definite function to perform. First, there is the ordinary switcher for handling cars in a more or less level, terminal yard. Next, the transfer engine is used for delivering cars to other lines in yards separated by comparatively short distances, and lastly the hump yard engine which sorts the cars in a hump yard.

The regular yard engine is usually a six-wheel machine, formerly with a slope back tender. On one of our leading railways this class of yard engine has the following dimensions, and two examples are here given to illustrate the class. They are shown in Figs. 1 and 2.

These engines have a draw bar pull of about 31,800 lbs. and are used for passenger train switching, industrial work, light freight switching and light transfer work. The road engines which bring in the trains handled by these yard engines, have a draw bar pull of 57,600 lbs. The yard engine therefore has 55.2 per cent

which provides the firebox with a combustion chamber. They have a draw bar pull of 51,200 lbs. This brings the ratio of yard engine to road engine power up to 87.2 per cent, while the P. & L. E. remains as it was, at 80 per cent.

The first mentioned road uses a road engine of the Mikado or 2-8-2 type of the dimensions given below, and having a draw bar pull of 57,600 lbs. as mentioned above. The P. & L. E. with road engine of 44,100 lbs. tractive power, hauls trains ranging from 4,000 to 4,700 tons. This tonnage is handled by the switchers without difficulty as in the yard, grades are encountered as on the road and a heavy long-sustained drag is seldom required. The P. & L. E. has, however, come to use but two standard types of yard engine. One in the terminal yard, about equal in tractive effort to the road engine, and the other, with an increased draw bar pull of about 25 to 30 per cent is used for the hump yard, the lesser powered engine

equal to the roadster, as mentioned above and the hump yard engine, which is more powerful.

Here is the result, stated briefly and in its larger outlines of the practice of at least two railroads which have given the yard engine problem careful and serious thought with the idea of adapting means to an end. They have not been content to use old engines nor engines which were not satisfactory on the road simply because train orders and schedules had no longer to be followed, while the engines may have been coal eaters or slow starters, and the economy represented by their service was illusory.

These railways, alive to the fact that adaptation to function is practically a universal law of nature had experimented, kept records and devised a system which is not only a credit to the officials who had taken the comprehensive view of this service, but who have been able to give to their company a scientifically designed

method of doing the work of switching, transferring and classifying cars.

On the El Paso & Southwestern the standard switch engines develop about 33,000 lbs. tractive power, while the road engines develop from 40 to 60,000 lbs. tractive effort. The ruling grade on that system is 1 per cent., and there are many of these grades. The switching yards are

but it opens the door and indicates to those who have not yet taken the matter up seriously, the path to the scientific reduction of operating costs, the elimination of leaks in the service, and the more hearty and comfortable co-operation of the men who do the work.

Later on, the interesting and important question of how this adaptation of means

The officers elected at the Fifteenth Annual Convention of the National Machine Tool Builders' Association last month were:

President, Mr. J. B. Doan, American Tool Works Company, Cincinnati, Ohio; first vice-president, Mr. D. M. Wright, Henry & Wright Mfg. Company, Hartford, Conn.; second vice-president, A. H.

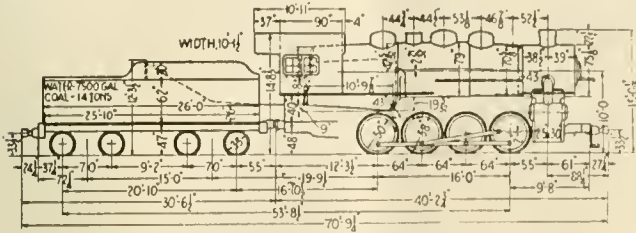

FIG. 3. TRANSFER YARD ENGINE.

Kind of main valve...Piston 14 in.	Heating surface superheater, 783 sq. ft.
Valve travel .....6½ in.	Heating surface grand total, 3,328 sq. ft.
Kind of valve gear, Improved Baker	Weight on drivers working order .....239,500 lbs.
Firebox length inside.....120¾ in.	Weight total of engine.....239,500 lbs.
Firebox width inside.....75¼ in.	Weight of tender loaded.....148,300 lbs.
Grate area .....46.6 sq. ft.	Weight of tender empty.....57,800 lbs.
Tubes, large .....30.5½ in.	Steam pressure .....180 lbs.
Tubes, small .....214.2 in.	Rating .....51.2 per cent.
Tubes, length over sheets...15 ft. 0 in.	These engines are equipped with
Heating surface tubes...2,314.2 sq. ft.	Gaines fire brick arch.
Heating surface firebox, inclu. arch flues .....230.8 sq. ft.	
Heating surface total.....2,545 sq. ft.	

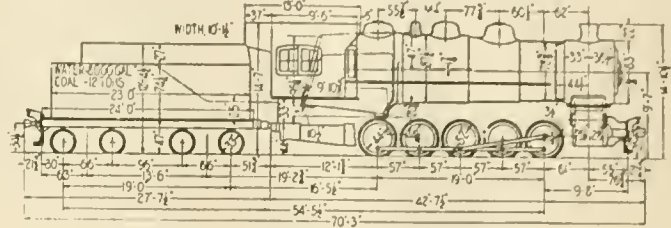

FIG. 4. HUMP YARD ENGINE.

Kind of main valve...Piston 12 in.	Heating surface firebox, inclu. arch flues .....197.0 sq. ft.
Valve travel .....5½ in.	Heating surface total.....4,619.6 sq. ft.
Kind of valve gear, Walschaerts	Weight on drivers working order .....270,000 lbs.
Firebox length inside.....108¾ in.	Weight total of engine.....270,000 lbs.
Firebox width inside.....73¼ in.	Weight of tender loaded.....149,600 lbs.
Grate area .....55.4 sq. ft.	Weight of tender empty.....58,960 lbs.
Tubes number .....447	Steam pressure .....210 lbs.
Tubes length over sheets...19 ft. 0 in.	Rating .....62.5 per cent.
Tubes diameter outside.....2 in.	
Heating surface tubes...4,422.6 sq. ft.	

as a rule level and yard engines, with the proportion something under the power of the road engines is found to handle the traffic where grades are not encountered, as in the yards, and where a time schedule for getting over the line does not exist. Speed recorders are used quite extensively on the El Paso & Southwestern, and the working and standing time

to ends work out in practice and of how yard engines are susceptible of improvement and are given increased efficiency by the use of appliances which were formerly only employed on road engines, may be taken up in our columns with a view of showing that yard service may be materially cheapened without in any way reducing its efficiency, and that in fact an

Tuehner, Cincinnati, Ohio, care Cincinnati Bickford Tool Company; secretary, Charles L. Taylor, care Taylor & Fenn Mfg. Company, Hartford, Conn.; treasurer, A. E. Newton, care Reed-Prentice Company, Worcester, Mass.; general manager, Charles E. Hildreth, care Whitcomb-Blaisdell Machine Tool Company, Worcester, Mass.

The program for the convention was of a two days' extent, October 24 and 25. On the first day after the general business, Mr. Frank F. Dresser gave an address on "Health Compensation." On Wednesday afternoon an address was given by Mr. James A. Emery of Washington on "The American Business Man's Duty to His Country." This, with the general business of the association, wound up the afternoon session and completed the program.

**George W. Wildin Goes Motoring.**

Many railway men use automobiles for pleasure trips around their homes, but when they undertake a journey of hundreds of miles we nearly always find them reclining in a soft section of a Pullman car.

Mr. George W. Wildin, mechanical superintendent of the New York, New Haven & Hartford Railroad, has proved himself a little more enterprising as a traveler. He came originally from Kansas, and his mother still lives in Topeka. A short time ago Mr. Wildin was moved to visit his mother and instead of railroad travel he packed his family in an automobile and traveled the whole distance by that means. The distance is about 1,600 miles and he enjoyed it.

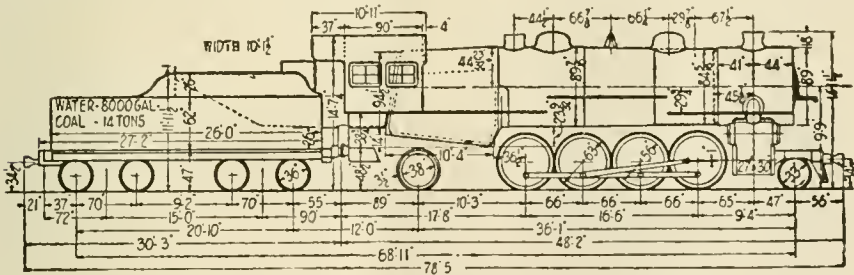

FIG. 5. OUTLINE OF MIKADO OR 2-8-2 ROAD ENGINE.

Kind of main valve...Piston 16 in.	Heating surface superheater, 1,626 sq. ft.
Valve travel .....7 in.	Heating surface grand total, 6,366 sq. ft.
Kind of valve gear, Walschaerts	Weight on drivers working order .....245,000 lbs.
Firebox length inside.....114¾ in.	Weight on front truck.....27,500 lbs.
Firebox width inside.....75¼ in.	Weight on back truck.....49,500 lbs.
Grate area .....60.03 sq. ft.	Weight total of engine.....322,000 lbs.
Tubes, large .....43.5¾ in.	Weight of tender loaded.....162,300 lbs.
Tubes, small .....295.2 in.	Weight of tender empty...65,000 lbs.
Tubes, length over sheets...21 ft. 0 in.	Steam pressure .....190 lbs.
Heating surface tubes...4,494 sq. ft.	Rating .....57.6 per cent.
Heating surface firebox, inclu. arch flues .....246 sq. ft.	
Heating surface total.....4,740 sq. ft.	

of yard engines have been subjected to scientific analysis with beneficial results.

The net result of the method of adapting means to ends, such as the design of locomotives not only for switching service in general, but for what one might call the specialties of that service, supplemented by a careful analysis of the time in which each particular part of service occupied, has had a powerful influence in the securing of real economy,

economy of power may be attained which in some cases has actually proved that an engine might in certain circumstances be dispensed with, and so produce a definite form of economy in the service, which none can successfully gainsay. Yard engines can with advantage use superheaters, brick arches, power reverse gears, efficient valve gear and other well-known appliances which make for prompt service at reduced cost.

# Electrical Department

## Advantages of the Electro-Magnet System— Catechism of the Electric Locomotive Continued

In the September and October issues we have described the construction of the electro-pneumatic control and the electro-magnetic control.

There are certain advantages obtained by the use of the electro-magnetic system. First, the switches are operated by air, and a constant pressure is thus obtained between the contacts carrying the current, independent of what the voltage may be on the third rail. In the case of the electro-magnetic switch the switch is closed by a solenoid, so that if the voltage to this solenoid becomes too low the pull of the solenoid will be decreased, and the pressure will be less between the main contacts. On heavy traction systems, this is not much of a factor, as the third-rail voltage, for instance, is usually nearly constant, and does not drop appreciably with heavy loads. On smaller systems, where the feeder supply is not on the same basis as the larger system, the voltage may reduce considerably when the locomotive is starting up and hauling a heavy load, so that there will be an appreciable difference in the pressure on the contacts. This pressure occurs at the time that maximum current is flowing through the contacts, so that there is more liability, in the case of the electro-magnetic system, of the contacts becoming "frozen," or, in other words, "welded" together, than in the electro-pneumatic system.

Second. The control circuit for operation of the electro-pneumatic system is taken from a storage battery of low voltage, usually about 32 volts. This is of an advantage since all of the control circuits are at this voltage, and since these control circuits connect with the master controllers, there is no high voltage near the operator. With the electro-magnetic system, at least 600 volts is usually used for the operation of the solenoids, and it is necessary to lead in to the master controller a 600-volt supply. These control wires are protected by fuses, and with the modern construction this high voltage is amply protected.

In addition to the main control apparatus, there is usually on all locomotives apparatus which contributes to the correct operation of the locomotive, but which, in reality, are minor to the main control apparatus.

CATECHISM OF ELECTRIC LOCOMOTIVE.

Q.—On AC-DC locomotives, such as those in use on the New Haven locomotives, it is very essential that the operation of the trolleys and third rail shoes are un-

der control of the engineer. How is this accomplished?

A.—Air pressure is used to operate the shoes and pantagraph trolleys, and the air pressure to the operating cylinders on the third rail shoe mechanism and on the pantagraph is controlled by magnet valves, these magnet valves being energized from push buttons located usually on the master controller. The battery current passes

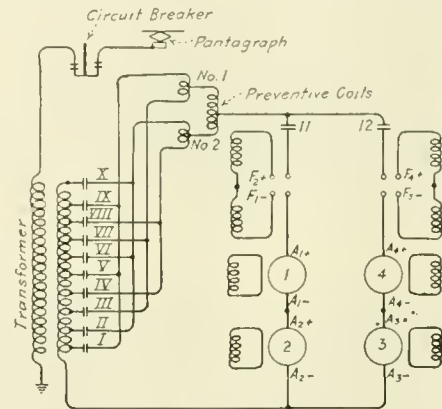

FIG. 21. SCHEMATIC DIAGRAM MAIN CIRCUITS A. C. LOCOMOTIVE.

through the contacts of the push button and energizes a valve similar to the valves used in the electro-pneumatic system. With this remote control, it is possible for the engineer to drop his third rail shoes previous to entering on the DC zone, and when leaving the DC zone to raise the

Step	CB	I	II	III	IV	V	VI	VII	VIII	IX	X	11	12
Off	○												
	○	○										○	○
	○	○	○									○	○
	○	○	○	○								○	○
1	○	○	○	○	○							○	○
2	○	○	○	○	○	○						○	○
3	○	○	○	○	○	○	○					○	○
4	○	○	○	○	○	○	○	○				○	○
5	○	○	○	○	○	○	○	○	○			○	○
6	○	○	○	○	○	○	○	○	○	○		○	○
7	○	○	○	○	○	○	○	○	○	○	○	○	○

FIG. 22. SEQUENCE OF SWITCHES FOR MAIN CIRCUIT DIAGRAM A. C. LOCOMOTIVE.

overhead trolleys, and also raise the shoes.

Q.—What apparatus is provided so the engineer will know what power is being taken by the motors?

A.—Electrical instruments known as ammeters are connected up with the circuit, so that the amount of current going

to the motor is indicated on the dial. In this way, the engineer will so operate the master controller, that overloads will not be applied to the motor.

Q.—What is the construction of the ammeter?

A.—It consists of a dial with a movable hand, the dial containing a scale graduated in hundredths or thousandths of amperes.

Q.—What happens if too much current is sent into the motors? Or, in other words, if the engineer notches up his master controller too rapidly?

A.—The power is cut off automatically from the motors.

Q.—How is this accomplished?

A.—By means of an overload trip.

Q.—How does the overload trip operate?

A.—The overload trip is fitted to the circuit breaker or to one of the unit switches, and is so arranged that when the current exceeds a predetermined amount the overload trip operates, open circuiting the control wire to the circuit breaker main contact switches. The breaking of the control circuit to the switches causes same to open and the current supply is interrupted.

Q.—What must be done to establish the circuit again to the motors?

A.—The circuit breaker must be reset, so that when the master controller is pulled up the switches will come in.

Q.—How is the breaker reset?

A.—The breaker is reset automatically by means of a push button located on the master controller. The battery current is connected to a small trip circuit which unlocks the overload trip, returning it to the normal position, in which position battery current can flow to the magnet valves and close the circuit breaker switches.

Q.—What must be done by the engineer before the circuit breaker can be reset?

A.—The master controller must be thrown to the "off" position.

Q.—Why is this advisable?

A.—So that the circuit breaker can not be reset with the master controller in the "on" position; with the controller in this position, many of the switches are closed, and the current would be thrown suddenly on to the motors, and not gradually, as is the case when the master controller is operated notch by notch.

Q.—On what other occasions does the circuit breaker blow?

A.—In case of grounded motors, or any other false operation or short circuit, sufficient current will flow to cause the cir-

cuit breaker to trip, thus opening the circuit and protecting the apparatus.

Q.—Are the sequence of switches the same for D.C. and A.C. locomotives?

A.—No; they are entirely different, since in one case alternating current is used as the source of power, requiring a

Q.—What is the object of the preventive coils?

A.—As mentioned above, we have leads I and III connected across a preventive coil. These taps from the transformer are of different voltages, I being lowest and X highest, the voltage of I being ap-

Q.—What benefit is gained by using the large number of transformer taps and operating with four in running position?

A.—With this arrangement very smooth acceleration is obtained. It is necessary, on locomotive work, as well as car work, to give a continuous flow of current to the motor and not open circuit between points. It is, therefore, necessary, to be able to pass from one tap on the transformer to the other tap without open circuiting, which means that both taps must be in the same time. Some preventive must be used to prevent a short circuit between these different voltages, and the preventive coil works out very nicely. It would be possible, and is done, in many cases, to have a fewer number of transformer switches in at one time. The advantage in having four is that these four switches are carrying the total current to the motor, so that each switch is only carrying one-fourth of what one switch would carry, and can be made one-fourth as large, which is an advantage. These preventive coils are wound so that a short circuit is prevented between the taps connected with same, although at a different voltage, but they offer very little impedance and resistance to the flow of the current passing to the motor.

Q.—How are these preventive coils constructed?

A.—They are made of a few turns of copper strap, surrounded by iron, and resemble a small transformer. These two

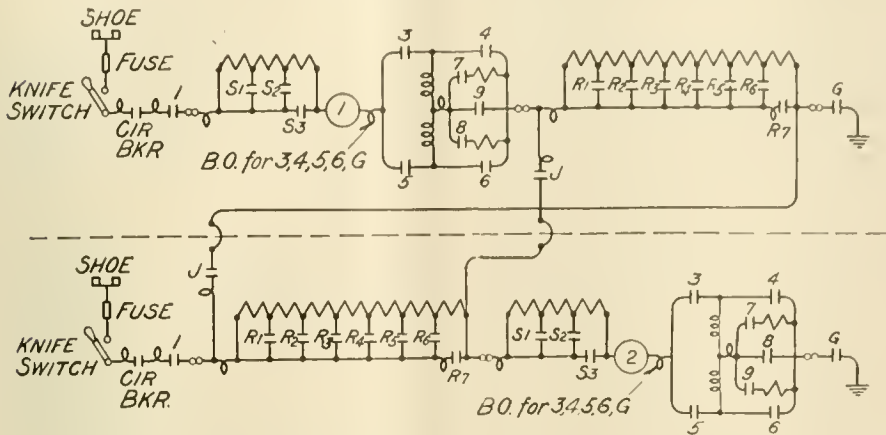

FIG. 23. MAIN MOTOR CIRCUITS FOR D. C. LOCOMOTIVE.

transformer, and in the other case direct current is used, which is applied directly to the motors.

Q.—Taking the case of an alternating current locomotive, what is the arrangement of motors, switches, etc., and how is the power gradually applied to the locomotive, so as to give smooth acceleration?

A.—A schematic diagram of connections for an A.C. locomotive is shown by Fig. 21. This schematic diagram shows the pantagraph trolley which collects the power from the overhead wire, the circuit breaker through which the high-tension current passes, and the transformer, which is of the double-coil type—the other end of the primary of the transformer being connected to ground. The secondary of the transformer has, in this case, ten taps which are connected to switches marked from I to X. These taps, after passing through the switches, connect to four leads running to the preventive coils, every fourth tap connecting to the same lead. From the preventive coils one lead is taken as the source of supply, and divides into two circuits, feeding two motors in series in each circuit.

Q.—What takes place when the engineer notches up on the master controller?

A.—Referring to the sequence of switches for Fig. 22, note that first switch I closes, then II, then III, and then IV. This is the first running position. Tracing through these four switches, it is found that switches I and III connect across preventive coil No. 1; II and IV connect across preventive coil No. 2. Referring to the diagram, these two preventive coils are then connected together by the large preventive coil, from which is taken one tap. When the master controller is put in the second position, V switch comes in and I switch drops out, the V taking the place of I, and so on, step by step.

proximately 200 volts and X approximately 500 volts. It would be impossible to connect leads I and III directly together, as there would be a difference of probably 50 to 60 volts, which would cause a severe short circuit. The preventive coil No. 1 serves as a preventive of this short circuit. The same condition applies with preventive coil No. 2. By connecting on the large preventive coil

Control Notches	Switches #1 Half										Switches #2 Half										Control Notches						
	1	3	4	5	6	J	G	R1	R2	R3	R4	R5	R6	R7	7	8	9	R1	R2	R3		R4	R5	R6	R7	7	8
Off Series #1	1																										
	2																										
	3																										
	4																										
	5																										
	6																										
	7																										
	8																										
	9																										
	10																										
	11																										
	12																										
	13																										
	14																										
	15																										
Series F.F	16																										
	17																										
Series N.F	18																										
	19																										
	20																										
Parallel #1	21																										
	22																										
	23																										
	24																										
	25																										
	26																										
Parallel F.F	27																										
	28																										
	29																										
Parallel N.F	30																										
	31																										
	32																										
	33																										
	34																										
	35																										
	36																										
	37																										
	38																										
	39																										
	40																										

FIG. 24. SEQUENCE OF SWITCHES FOR MAIN CIRCUIT DIAGRAM FOR D. C. LOCOMOTIVE.

the four different voltages of leads I, II, III and IV are combined into two voltages, and the large preventive coil prevents a short circuit between these two. Taking off the one lead from the large preventive coil, we have a voltage which is the mean of the sum of the voltages I, II, III and IV.

halves of the coils are wound so that in the case of a short circuit the coils are added together and offer a large impedance and resistance to a short circuit, but when drawing the main motor current, the current flowing in the two leads, say from switch I and III, passing through the windings of the preventive

coil neutralize each other so that very little resistance is offered, and the flexibility of control is obtained at high efficiency.

Q.—What is the arrangement of the D.C. circuit?

A.—Arrangement of the D.C. circuit is shown by Fig. 23, which shows the schematic diagram of the main motor circuit for a large D.C. locomotive consisting of two halves. The sequence of switches is shown by Fig. 24.

Q.—How is smooth acceleration obtained?

A.—By means of inserting resistance in the circuit when starting up and cutting out this resistance, step by step, as the speed in the train is increased. Power enters the circuit breaker No. 1 switch of No. 1 half, passes through the resistance, thence through motor No. 1, through additional resistance, through lead and switch "J" of the No. 2 half, through more resistance, thence through No. 2 motor and then to ground. Referring to the sequence, note that the resistance is cut out, step by step, until all of it has been removed, and when the switch "J" closes of the No. 1 half, the No. 2 motors are in full series position.

Q.—Are the motors operated always in this position?

A.—No; in order to get greater speed, the motors are connected in parallel, and the arrangement of circuits is easily followed from the sequence of switches. This particular locomotive is suitable, or, rather, is adapted for field control.

Q.—What is the advantage to be gained from field control?

A.—There are a larger number of running positions and the operation is more economical, due to the possibility of obtaining a high starting torque with small current, and then the possibility of cutting out some of the field and obtaining higher speed by running on a field notch. In this particular case, the running points are noted as full field, and normal field positions on the "Sequence of Switches" diagram. Fig. 24.

#### Northern Railway of France in War Time.

It is noteworthy that in September, 1914, of the 2381 miles of the Northern Railway of France, there remained only 428 in operation, the remainder being in the hands of the German invaders. Yet it was this section which carried out some of the transportation wonders of the war. In December, 1915, the mileage available had increased to 1,225. Of 768 stations, 346 were then in the hands of the Germans or closed for traffic.

#### Boiler Tubes and Scale.

Eminent authorities agree that a layer of scale one-tenth of an inch thick, and a steel boiler plate ten inches thick, offer exactly the same resistance to the passage of heat.

## Improved Landis Threading Machine for Hollow Safety Screws

The Landis Machine Company, Waynesboro, Penna., have recently placed upon the market threading machines equipped with special carriages for threading hollow safety set screws, as shown by the accompanying illustration. While these machines were primarily designed to thread hollow safety set screws, they may be employed in threading stock where there is a continuous thread and a similar method of holding. The carriages proper are stationary and support two spindles, which have a free horizontal movement. These spindles are brought to the threading die heads by means of weights which are attached by chains to the levers operating the spindles. These weights exer-

this purpose, at the rear of the machine.

These machines may also be used for threading standard bolts by attaching automatic opening and closing attachments for the die heads. When standard bolts are threaded, the heads of the spindles on the carriages are fitted with bolt sockets for the various diameters within the range of the machine. These machines are equipped with Landis All-Steel Die Heads, which employ long-life chasers.

#### American Locomotives in South Africa.

In South Africa, previous to the outbreak of war in Europe, railway material for government use was admitted free

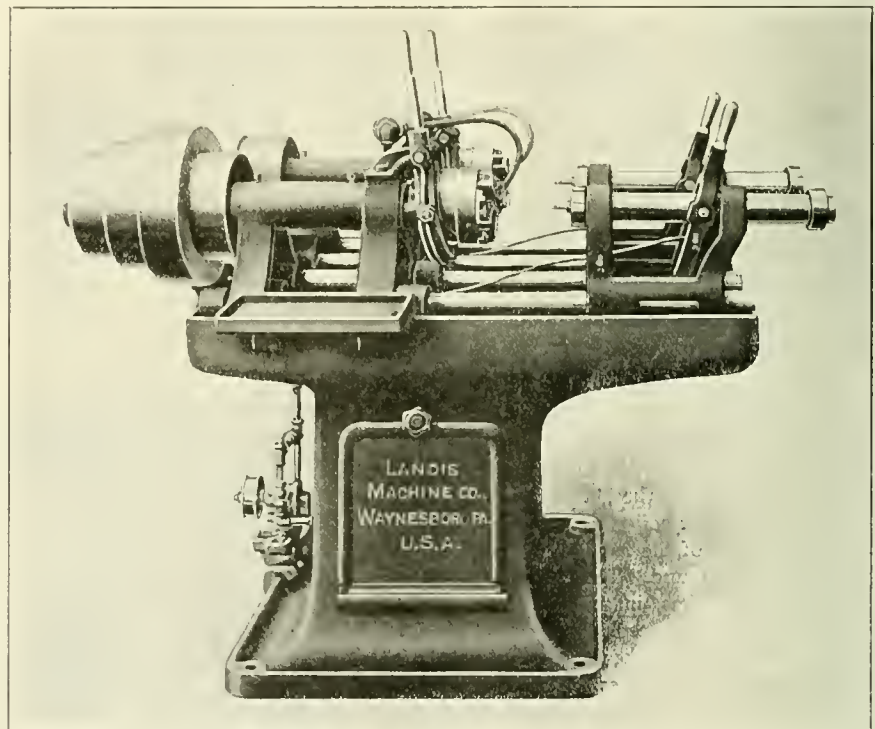

LANDIS MACHINE FOR THREADING HOLLOW SAFETY SCREWS.

cise a continuous force upon the spindles in the direction of the die heads, making it unnecessary for the operator to advance the stock for the threading operation.

The heads of the spindles are bored and fitted with mandrels for holding the set screws. A collar is placed on the rear of each spindle, making it adjustable for cutting any desired length of thread. For the threading operation the set screw is placed upon the mandrel and the spindle automatically forces it into the die head. When the screw is threaded it remains in a tube which extends through the spindle from the face of the threading die head to the rear of the machine. The subsequent threading of screws forces the finished pieces through the tube, where they drop into a receptacle placed, for

of duty. By an act of Parliament, all tenders were considered on a basis of 25 per cent preference for goods of British manufacture. This new act practically excluded all but British-made supplies. Railway officials soon found themselves unable to handle the growing traffic, or to obtain the required new rolling stock. The preference was promptly abolished, and a number of contracts was placed in America. Twelve narrow gauge locomotives were delivered in June, two months before the contracted delivery. The new locomotives are of the 2-6-0 type, and are the heaviest and most powerful of their gauge in South Africa. This order has proved very successful. And no doubt future orders will continue to come to America.



# The Process of Electric Arc Welding

## Its Particular Adaptability to Railroad Work—The Carbon Electrode and the Metal Electrode Process—Important Reduction in Voltage

The rapid growth of electric arc welding is one of the marked mechanical features of the present decade. Perhaps its most serviceable field is in its use in railroad repair shops. In the welding of flues, in fire-box and frame repairs, in the repairing of engine and truck frames, corroded mud rings, in the upbuilding of flat spots in driving wheels, and the welding of driving wheel spokes as well as the welding of cracks in fire-box sheets and bridges in flue sheets, it is daily coming into more general and extended use, and the recent improvements made in the means and methods of its appliance are such that it has now reached a degree of adaptability that it has become an indispensable adjunct in general railroad repair work. Already nearly all of the larger locomotive repair shops, and many car shops are fully equipped with arc welding appliances, and in nearly every instance the process is meeting with warm approval.

Doubtless the general depression occurring in railroad work in recent years has to a considerable extent hindered the progress of its adoption, but now that vastly improved conditions are upon us the growth of this industry is becoming more rapid. Another cause of the apparent degree of slowness has been the fact that in many instances the workmen were not sufficiently instructed in the details of the work. This drawback, however, bids fair to be remedied, and already special instructors are coming to be more readily looked upon as essential to the introduction of the appliance. Even schools are being established which, with some necessary federal or state regulation, are sure to be productive of furnishing a higher degree of skill among those seeking to obtain full knowledge in this new sphere of industrial activity.

Electric or incandescent welding, or, as it is generally called, butt and spot welding, consists of two parts of metal being joined in a solid mass when placed together and by means of the necessary equipment a heavy current of electricity is caused to pass from one piece of the metal to the other, thereby heating both ends of the metal to the fusing point when the two parts are pressed together and the weld is made. Welding without pressure is also accomplished by the fusing of the two metals by simply causing them to meet and unite in cooling. Generally speaking, there are two classes of electric arc welding—the carbon electrode process in which the electric arc is drawn between the metals that are to be welded and a carbon electrode, and the metal electrode process. In the latter process

the electric arc is drawn between the metal to be welded and a metal electrode.

The requirements are an adaptable source of electric direct current supply with a readily adjustable control furnished with means for holding the electrode so that it can be completely controlled by the operator. A protective covering is also necessary for the operator, also suitable filling material, which in the early days of electric welding, was usually of the same metal as that of the metal being operated upon, but recent extensive experiments have developed alloys that are not adversely affected by the intense heat of the arc. This specially alloyed steel is in the form of an electrode and is composed of a homogenous alloy combined with such excess of manganese as will be transferred across the welding arc and be left in the welded joint to add substantially to its toughness.

There has also recently come into use a manganese copper alloy welding metal as an electrode forming an arc, which is composed of iron homogeneously combined with such an excess of manganese and copper over the amount burned out in the arc as will retain in the welded joint a substantially additional degree of toughness and ductility due to said excess. In general practice these filling pieces of metal are fed into the welder and melted into place mixing with the pieces to be welded similar to the fusion of solder by the application of a blow torch.

The most satisfactory electric arc welding is done by direct current only. In the use of the alternating current for arc welding the arc is very unsteady, and also noisy and difficult to handle. Not only so, but the arc has a tendency to become extinguished as the current passes through the zero point. The electric power necessary is what is known as a low voltage application, and although direct currents of 110, 220 or even 550 volts may be used in welding, this practice is very wasteful of energy, and while it may be used in emergencies, or when power can be secured cheaply, better results are obtained with 75 volt circuits, and recent improvements have demonstrated the fact that volts below 50 and even as low as 35 are already successfully in operation. Appliances furnished with perfectly controlling devices with as low voltage as the latter figures referred to are already in service, and bid fair to come rapidly into popular favor.

The most convenient and economical method of welding is to use a motor generator set, the motor being constructed suitable for operation in the existing cir-

cuit, and applied to drive a low voltage generator. Either shunt or compound wound may be used. The former is adapted for one arc only, the latter is preferable if several arcs are intended to be supplied from the same unit. The power of the motor-generator set should be adapted to the class of welding to be done and the number of arcs to be expected working coincidentally. The temperature rating is not the only consideration, as the service is generally of an intermittent kind, although when the arc is used in cutting, the service may be nearly continuous when due allowance must be made for the necessities of the conditions.

When compound wound, commutating poles should be provided on account of the heavy overloads expected in the continued and heavier welding work. What is known as flat compounding may be sufficient, while again it may be necessary to over-compound 3 or 4 per cent of full load. This is especially the case when an induction motor is used, on account of the lessened speed when the heavier load comes on the motor. Recent improvements in the generating equipment are such that when commutating poles are used, a simple and perfect control system has been devised that meets every emergency.

In closing this brief article it may be stated that in next month's issue fuller details of the most approved methods of electric arc welding will be presented with illustrations of the appliances that are now becoming standard on the Erie railroad, the Santa Fe and other leading railroads, together with reproductions of photographs of welds that have been made, and the relative costs of such work, all showing a great saving as compared with the old methods.

### Inspection Trip.

Fifty members of the Traffic Club, of Brooklyn, visited the Bush Terminal recently and inspected the loft buildings, warehouses, cold storage plant and piers. The Traffic Club, which is making a study of the railroad and shipping conditions in the greater city, will hereafter make weekly visits to all the industrial centers and large factories in order to more thoroughly familiarize itself in helping to work out the problems of local industrial expansion. P. L. Gerhardt, traffic manager of the Bush Terminal Company, was in charge of the tour, which was followed by a dinner at the terminal.

Many subjects affecting traffic men were discussed.

# Difference in Braking Power in Cars

## Variation in Piston Travel and Cylinder Pressure Cause of Shocks

By W. E. THOMSON, Fort Worth, Tex.

I herewith hand you a chart showing a sixteen-car train. It shows the piston travel and the cylinder pressures developed in each cylinder. I am enclosing a cylinder pressure table that shows the pressure for each inch of piston travel and the difference in braking power between cars that have different cylinder volumes. A glance at this sheet should satisfy anybody where the trouble is that causes shocks in handling trains. In the pressure table I have left off the half-pounds and added a half-pound once or twice in order to cut out the fractions.

two cars would receive eleven and seven pounds, if they had the same kind of triple valves, if they were equipped with triples that had the quick service feature the pressure would be much higher, possibly five or ten pounds more in these two cylinders. At any rate, we would have at least 1500% difference in braking power between the second and third car. If the train is moving at a slow speed the shock will be terrific. If the speed is high the shock will be very light and still less if a heavy brake pipe reduction is made. High speed is the only shock-

themselves to the cylinders having small volumes would serve the committee's purpose. The pipe should be connected to all cylinders throughout the train, same as the driver brake cylinders are connected. Then the engineer who has made a 5, 7, or a 10-pound brake pipe reduction on a train of ten or twelve cars with seventeen varieties of cylinder volumes could feel easy, contented and happy with the thought that the cylinder pressures would equalize in due time without any effort on his part. Another good feature of this arrangement is the effects of cylinder leakage, which would be effective in all cylinders.

I would thank you if you would have your air brake expert state just how this train (the one described on chart) could be handled without shocks. Please explain fully about "steps" and "loosing time, if necessary," in order to make smooth stops. If it is possible, I would like to learn how to apply the air to a 4-in. cylinder; also to one that has 10-in. piston travel. I know there must be quite an art in performing the operation. Mr. Turner states the 4-in. cylinder receives the pressure in half the time the 10-in. cylinder does. That is what bothers me, how can I put 21 pounds in one cylinder and only one pound in the other and handle the train smoothly.

Cylinder's pressures, resulting from a 51-lb., 7-lb. and 10-lb. brake pipe reductions. No leaks of any kind considered. And the difference in braking power between cars, caused by unequal piston travel.

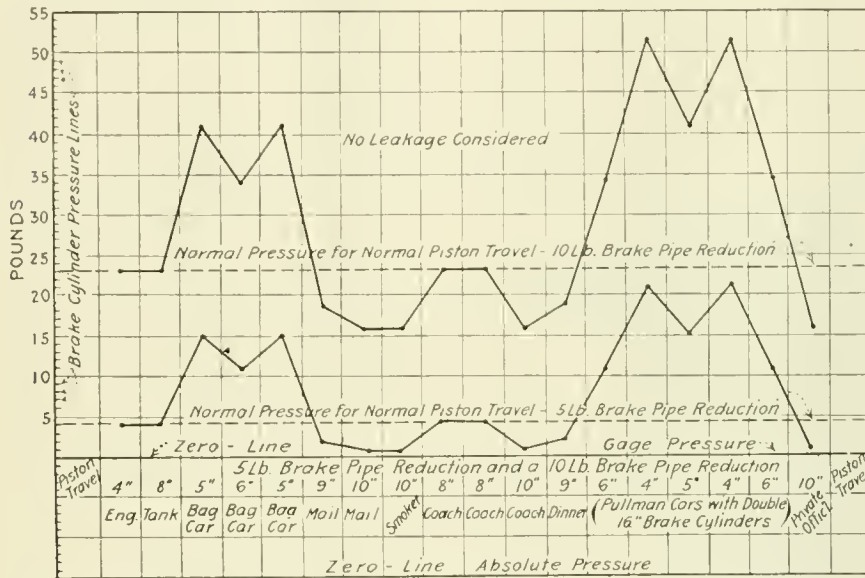

This train consists of 16 passenger cars, the train line volume is a little more than 18 thirty-four foot cars, but the cylinder volumes are equal to 95 eight inch freight cylinders (11 cylinders 18 ins. diameter, 10 cylinders 16 ins. diameter), requiring same amount of air to handle it from the brake cylinder point of view. Assuming that the double equipment has the same pressure in both cylinders.

Those who can't understand unequal cylinder pressures and its bad effect in handling trains have studied too much about the brake valve, ports, passages, valves, and have not studied the brake cylinder and the different pressures it develops for the same brake pipe reduction.

Can anyone with any air brake knowledge figure out that the engineer can by some mysterious manipulation of the brake valve equalize the pressures in the brake cylinders, and this is what he must do in order to prevent shocks and jerks. For example, the engine has the "ET" equipment, back of the tank the first two cars have 9-in. and 10-in. piston travel, the third and fourth cars have 6-in. and 7-in. piston travel, consulting pressure table, we find for a five-pound brake pipe reduction the engine and tank brakes, which are normal, receive four pounds cylinder pressure. The first two cars back of tank have the old style, quick action triple, they would receive two and one pounds in the order named; the next

absorber the engineer can take advantage of.

After consulting Mr. Turner's charts and papers, we are beginning to get a little insight into the air brake apparatus. We find things to be quite different from what we were led to believe. That the brakes need something more than brake-valve manipulation, that the cylinders need very serious attention and the pressures must be kept equal if we expect to have smooth-handled trains.

I am led to believe from the remarks on slack action, as noted in your June issue, that the committee desires the engineer to draw off the brake pipe pressure in sections or "steps," they fail to give the size of steps that would be best suited to perform the desired operation on the brake cylinder; they also fail to explain what sizes of cylinder volumes we are to operate on. Perhaps they are like the enclosed sketch, varying from 4-in. to 10-in. Personally, I think that an equalizing pipe with restricted application ports which would automatically apply

Piston Travel.	Brake Pipe Reduction.	Lbs. Cylinder Pressure.	Per Cent. More Braking Power Than 10 Ins. Piston Travel.
3	5	21	2,800
4	5	21	2,000
5	5	15	1,400
6	5	11	1,000
7	5	7	600
8	5	4	300
9	5	2	100
10	5	1	
11	5	0	000
12	5	0	000
<hr/>			
3	7	45	542
4	7	33	371
5	7	25	257
6	7	19	171
7	7	15	114
8	7	12	71
9	7	8	14
10	7	7	
11	7	5	28 Less than 10 ins.
12	7	3	133 Less than 10 ins.
<hr/>			
3	10	60	257 More than 10 ins.
4	10	52	225
5	10	41	156
6	10	34	112
7	10	27	62
8	10	23	43
9	10	18	12
10	10	16	
11	10	13	18 Less than 10 ins.
12	10	11	31 Less than 10 ins.

# Items of Personal Interest

Mr. F. B. Rosencrans has been appointed signal inspector of the Great Northern with office at St. Paul, Minn.

Mr. F. M. Fryburg has been appointed master mechanic of the Great Northern, with office at Great Falls, Mont.

Mr. J. C. Benson has been appointed master mechanic of the Montana division of the Great Northern, with office at Havre, Mont.

Mr. A. H. Kendall has been appointed master mechanic of the Canadian Pacific, with office at Toronto, Ont., succeeding Mr. W. J. Pickrell, transferred.

Mr. W. R. Elmore, formerly acting master mechanic of the Nevada Northern, has been appointed master mechanic on the same road with office at East Ely, Nev.

Mr. J. M. Conners has been appointed car foreman of the Baltimore & Ohio, with office at Pittsburgh, Pa., succeeding Mr. E. W. Miller assigned to other duties.

Mr. H. A. Macbeth, superintendent of motive power of the New York, Chicago & St. Louis at Cleveland, Ohio, has been appointed assistant to superintendent of motive power.

Mr. B. W. Blue, formerly mechanical foreman of the Louisville & Nashville at West Lexington, Ky., has been appointed acting master mechanic succeeding Mr. McCuen, resigned.

Mr. B. J. Farr has been appointed master mechanic of the Western lines of the Grand Trunk, with office at Battle Creek, Mich., succeeding Mr. W. H. Sample, transferred.

Mr. W. T. Wischert has been appointed road foreman of engines of the Montana division of the Northern Pacific, with office at Butte, Mont., succeeding Mr. William Dean, resigned.

Mr. B. H. Davis, formerly road foreman of engines of the Delaware, Lackawanna & Western has been appointed assistant master mechanic on the same road with office at Scranton, Pa.

Mr. M. J. Flannery, formerly master mechanic of the Minot division of the Great Northern at Minot, S. D., has been appointed general master mechanic on the same road with office at Great Falls, Mont.

Mr. William Kelly, formerly general master mechanic of the Great Northern at Spokane, Wash., has been appointed assistant superintendent of motive power on the same road with offices at Spokane, Wash.

Mr. G. W. Taylor has been appointed roundhouse foreman of the Rock Island, with office at Dalhart, Tex., and Mr. W. B. Crow has been appointed to a similar

position on the same road with office at Herington, Kans.

Mr. J. E. Baker, formerly general sales manager of the Chicago Car Heating Company, Chicago, Ill., has been elected vice-president. He was for a number of years assistant superintendent of machinery of the Illinois Central.

Mr. George Durham, formerly master mechanic of the Delaware, Lackawanna & Western at Scranton, Pa., has been appointed superintendent of motive power and cars of the Wheeling & Lake Erie, with office at Brewster, Ohio.

Mr. Harry A. Pike has been appointed assistant to the president of the Call Switch Company, New York. The company which has been located for several years at Denver, Colo., has removed to the Singer building, New York.

Mr. F. H. Regan, formerly superintendent of shops of the Delaware, Lackawanna & Western at Scranton, Pa., has been appointed master mechanic on the same road, with office at Scranton, Pa., succeeding Mr. George Durham.

Mr. Charles Lounsbury has been elected president and general manager of the American Railway Supply Company with office at 136 Charles Street, New York, succeeding the late Mr. Walter Chur who died recently at East Orange, N. J.

Mr. Edward Wray, formerly business manager of the Railway Electrical Engineer, has resigned to accept the position of assistant to Mr. R. C. Lamphier, general manager of the Sangamo Electric Company, with offices at Springfield, Ill.

Mr. N. C. Bettenberg has been appointed master mechanic of the Minot division of the Great Northern with office at Minot, N. D., and Mr. J. J. Dowling has been appointed to a similar position on the same road with office at Delta, Wash.

Mr. George W. Daves has been appointed a representative of the signal department of the Railroad Supply Company, with offices at 30 Church Street, New York. Mr. Daves was engaged for several years as signal engineer on the Chicago & Alton.

Mr. Oliver J. Smith has been appointed manager of the Lima Locomotive Works, Inc. Mr. Smith has had a wide experience on the railroad in construction work, and was for a number of years piece work supervisor with the American Locomotive Company in New York.

Mr. C. R. McKinsey has been appointed master mechanic of the Washington Terminal Company, with office at Washington, D. C., succeeding Mr. C. B. Cramer,

acting master mechanic, and Mr. C. A. Rossiter has been appointed general car foreman on the same road, succeeding Mr. A. F. Swanick, acting general car foreman.

Mr. H. E. Stevens, formerly engineer of bridges on the Northern Pacific, has been appointed chief engineer on the same road with office at St. Paul, Minn. Mr. Stevens began railway service with the Northern Pacific in the bridge department in 1904, and in 1907 he was appointed engineer of bridges until promoted as above.

Mr. E. C. Fischer, formerly assistant manager of the Cooke and Rogers works of the American Locomotive Company, has been appointed manager of the Cooke works of that company with office at Paterson, N. J. Mr. Fisher was foreman in the Richmond Locomotive Works at Richmond, Va., from 1899 to 1910, and latterly transferred to the Cooke and Rogers Works at Paterson as above.

Mr. A. R. Ayers, formerly principal assistant engineer, equipment department of the New York Central lines east of Buffalo, with office at New York, has been appointed superintendent of motive power of the New York, Chicago & St. Louis, with offices at Cleveland, Ohio. Mr. Ayers graduated from Cornell University in 1900, and served a special apprenticeship on the Lake Shore & Michigan Southern. From 1903 to 1905 he was special inspector; 1905 to 1906, night engine house foreman; 1906 to 1907, assistant general foreman at the Collinwood shops; 1907 to 1908, superintendent of shops at Elkhart, Ind.; 1908 to 1909, assistant superintendent Collinwood locomotive shops; 1909 to 1910, assistant master mechanic at Elkhart; 1910 to 1911, mechanical engineer on the same road, 1911 to 1912, general mechanical engineer, New York Central lines west of Buffalo, and latterly assistant engineer of equipment as above.

## OBITUARY

### Col. Robert C. McKinney.

The death is announced of Col. Robert C. McKinney, chairman of the board of directors of the Niles-Bement Tool Company, Plainfield N. J. He was born in Troy, New York, in 1861, and learned mechanical engineering in Cornell University. He became associated with the Niles Tool Works in 1877, and in a short time became general manager. The present Niles-Bement-Pond Company was organized by him in 1898.

### John D. Campbell.

After a prolonged illness the death is announced of John D. Campbell, at his residence in the Bronx Borough, New York. Mr. Campbell was a prominent figure in railroad circles for many years, and held high positions in some of the leading railroads and construction works, among which were superintendent of the Manhattan Elevated Railroad, assistant superintendent of motive power of the New York Central & Hudson River Railroad, superintendent of the Dickson Locomotive Works, Scranton, Pa. Mr. Campbell traveled extensively both in America and Europe and Asia, and was an authority both in the mechanical and operating departments of railways. He was born in Port Jervis, N. Y., in 1846, and received his early training in the Erie shops there.

### Convention of Railway Electrical Engineers.

The Association of Railway Electrical Engineers held their ninth annual convention at the LaSalle Hotel on Tuesday, October 31, continuing four days. Jos. A. Andreucetti, Secretary, Room 411, C. & N. W. Station, Chicago, Ill. A report will appear in the December issue.

### Mechanical Engineers Railroad Meeting.

The American Society of Mechanical Engineers will hold a meeting of the railroad section on Friday forenoon, December 8. A paper will be presented by A. F. Batchelder of the railway department of the General Electric Company, on the Mechanical Design of Electric Locomotives. Clasp Brakes will be treated by T. L. Burton of the American Brake Company, St. Louis, and J. E. Muhlfeld, president of the Locomotive Pulverized Fuel Company, will present a paper on Pulverized Fuel for Locomotives. The meeting is expected to be more than usually interesting and will no doubt be largely attended.

### Election of Officers of The Lima Locomotive Works

Lima Locomotive Works, Inc., held a directors meeting in New York on Oct. 20, 1916. This company is successor to the Lima Locomotive Corporation and has taken over all property and assets of the latter corporation. All the officials of the old corporation were re-elected as follows: J. S. Coffin, chairman of the board; A. W. Wheatley, president; J. E. Dixon, vice-president; W. D. Cloos, secretary and treasurer. The board of directors is as follows: J. S. Coffin, chairman; S. G. Allen, A. W. Wheatley, Franklin Q. Brown, Le Grand Parish, H. F. Ball and John E. Muhlfeld.

## Railroad Equipment Notes

The Great Northern will erect a 20-stall round house at Great Falls, Mont.

The Western Maryland is in the market for 20 Mallet type locomotives.

The Utah Copper Company has ordered 150 ore cars from the Pressed Steel Car Company.

The Pere Marquette has ordered 100 steel underframes from the Pressed Steel Car Company.

The British war office has ordered 100 locomotives from the American Locomotive Company.

The Missouri Pacific has ordered 1,500 general service cars from the American Car & Foundry Company.

The New York, Chicago & St. Louis has ordered 5,000 tons of rails from the Lackawanna Steel Company.

The Finland State Railways have placed an order with the American Locomotive Company for 20 locomotives.

The Orleans Railway (France) has ordered 50 Mikado locomotives from the American Locomotive Company.

John Marsch, Chicago, Ill., has ordered 6 six-wheel switching locomotives from the Baldwin Locomotive Works.

The Compagnia Espana Colonisation has given the American Locomotive Company an order for 6 locomotives.

The Worth Brothers Company, Coatesville, Pa., has ordered 2 four-wheel locomotives from the Baldwin Locomotive Works.

A contract is reported to have been let to the American Bridge Company for 5,000 tons of steel to replace the collapsed span of the Quebec bridge.

The Louisville & Nashville has ordered 6 coaches, 4 horse-baggage cars and 4 baggage and mail cars from the American Car & Foundry Company.

The Union Tank Line has arranged for the construction of 2,250 cars, some of which will be built in company shops and some by merchant builders.

The Kansas City Refining Company has ordered 26 40-ton 8,000-gallon and 24 50-ton 10,000-gallon tank cars from the American Car & Foundry Company.

The Pacific Great Eastern contemplates an expenditure of \$150,000 for

shops and round house at Squamish, B. C., and a round house at Lillooet, B. C.

The Pennsylvania is in the market for 4,000 to 6,000 trucks. Pennsylvania Lines west of Pittsburgh have ordered 4,000 trucks from the Cambria Steel Company.

The Duluth, South Shore & Atlantic has ordered 200 40-ton flat cars, 200 40-ton box cars, 100 50-ton hopper and 10 40-ton refrigerator cars from the Haskell & Barker Car Company.

The Harrison Railway Specialties Company has recently closed an order for 2,000 rotary ring steel dust guards for the Western Maryland, and an order for 500 wooden dust guards from the New York, Chicago & St. Louis.

The Long Island has ordered 6 ten-wheel (4-6-0) type locomotives from the American Locomotive Company. Cylinders will be 21 by 26 inches, driving wheels 60½ inches; total weight in working order, 178,000 pounds.

The Wheeling & Lake Erie has ordered 10 Mallet (2-6-6-2) type locomotives from the American Locomotive Company. Cylinders will be 25½ and 39 by 32 inches, driving wheels 63 inches, total weight in working order 435,000 pounds.

The Chesapeake & Ohio has ordered 25 Mallet (2-6-6-2) type locomotives from the American Locomotive Company. Cylinders will be 22 and 35 by 22 inches, driving wheels 56 inches, total weight in working order 435,000 pounds.

The Illinois Central is receiving bids on 400 combination ballast and general service and 600 steel gondola cars. Alternate bids have been asked on 600 composite wood and steel gondolas and on 600 all steel gondolas with new specifications.

The Louisville & Nashville has ordered 1,000 55-ton drop bottom steel gondola cars and 500 55-ton steel hopper cars from the Pressed Steel Car Company and is in the market for 750 steel underframes for gondola cars and 750 steel underframes for ventilated box cars.

The Paulista Railway of Brazil has ordered 4 Pacific type locomotives from the American Locomotive Company. They will have 23 by 26-in. cylinders, 66-in. driving wheels, and a total weight in working order of 220,000 pounds. They will also be equipped with superheaters.

The Chicago & North Western has ordered 500 steel ore cars from the Pullman Company, and has issued inquiries for 500



## A Clear Track

ahead, Railway men, when you protect your metal work with

# DIXON'S Silica Graphite PAINT

It has a world-wide reputation of over fifty years. Made in **FIRST QUALITY** only. Made for those who want **QUALITY, LONGER SERVICE** and **LOWEST COST** per year of service.

Because of the peculiar oily nature and flake formation of the pigment, Dixon's Paint has no equal in keeping moisture and gases away from the metal. Therefore metal properly painted with it resists corrosion longer than that painted with any other paint. That is the reason why leading railroads throughout the entire world use it as standard.

Write for booklet 69-B and long service records.

Made in **JERSEY CITY, N. J.**, by the

**Joseph Dixon Crucible  
Company**  
ESTABLISHED 1827

B-132

30-ton steel frame stock cars and 500 additional box cars. Prices are being secured now on 1,500 30-ton wooden box, 1,700 50-ton composite general service and 500 stock cars. The company may enter the market also for 20 to 50 tank cars and 300 to 500 ballast cars.

The Lehigh Valley Railroad announced that it had just placed an order for twenty-five new all-steel baggage and express cars. The cars, which will be constructed along the lines of a special design prepared by the railroad, will be sixty feet in length, have six-wheel trucks and all the latest improvements for this class of equipment. The cars will be constructed by the Pullman Company.

The New Orleans & North Eastern has authorized the installation of 23 miles of automatic block signals on its Alabama and Vicksburg lines. The equipment consists of 28 style "S" double case, upper quadrant, three-position, 10-volt, direct-current signals; 28 model 12 polarized and 37 model 13 neutral relays and necessary Keystone insulated rail joints. The apparatus is to be furnished by the Union Switch & Signal Company and installed by the railroad's forces.

### Eight Hour Law in Oklahoma.

Following the enactment of the eight-hour law the Oklahoma corporation commission has decided at once to advance freight and passenger rates as soon as the law goes into effect. This increase is to be a flat two per cent., this figure being arrived at by taking the bulk advance in cost of operation claimed by the railroads and applying thereto the known data of Oklahoma which is complete as the result of a rate case just closed in the Federal Court. It means that passengers will pay an additional one cent for every 25 miles traveled, or a rate of 2.04 cents a mile. If a rate under the present tariff is \$5 an additional 10 cents will be made.

### Machines for Pulverizing Coal.

The machines used for pulverizing coal are divided into two classes, the air-separation machines and screen machines. In the former class there is an upward current of air produced by a fan which has a carrying capacity sufficient to take with it the finest particles, but which will not lift the coarser ones. As soon, therefore, as the coal is reduced to the required degree of fineness this air current will lift the particles and take them away and will then deposit them in a receiving tank by means of a cyclone separator, which is usually vented in some manner to prevent the loss of dust. In the screen mill the coal is continually thrown against a screen which permits the fine particles to pass through, but

causes the coarser particles to fall back under the rolls. Pulverization can be effected in a tube mill or ball mill with an expenditure of power and cost not greatly different from that of the other types.

### Railway Fire Protection in Canada.

The prevention of fires in Canada has been under the control of the board of railway commissioners for the past four seasons with good results. It appears that there were 686 forest fires which originated within 300 feet of the railway lines under the board's control. The area burned was 37,263 acres, 33 per cent. being chargeable to the railways, 21 per cent. to other known causes, and the remainder unknown. The estimated damage was \$74,256, of which only 11 per cent. is chargeable to the railways. The causes assigned are, locomotives, 33.9 per cent.; railway employees, 9.5 per cent.; settlers, 12.5 per cent.; tramps, etc., 11.4 per cent.

### Testing Railroad Scales.

The two test cars of the United Bureau of Standards have been working to their utmost capacity to keep up with the increasing demand for tests on railroad-track scales. In Chicago 27 tests were made. In Indiana and Ohio 48 tests were made. The tests are being made with the cooperation of the weights and measures departments, and also with the boards of trade, state officials, and the railroads concerned.

### Niagara Falls Illuminated

Five batteries of 100 lamps each imbedded in reflecting hoods of ingenious construction, and distributed over a wide area through the water, spray and mists of the Falls of Niagara accomplish a nightly wonder that will be maintained regularly through the month of November, and resumed again on May 1, 1917. The light is of 50,000,000 candle power. The spectacle is beautiful and defies adequate description.

### Hardening Lathe Tools.

Heat a good quality of tool steel, not the high-speed variety, to a cherry red; plunge it into salt water until cold; pull out and hold over the fire until a drop of water will evaporate when placed upon it. Then plunge into cold water. This takes the hardening strain off the tool and prevents the edges from breaking out. In practice, a tool of this kind will work well on chilled spots and keep a sharp edge.

### To Put Copper Coating on Steel.

Dissolve bluestone in water and apply to the steel, or take a piece of bluestone, wet it in water, and rub it over the steel. Bluestone should be readily secured in any drug store.

## Books, Bulletins, Catalogues, Etc.

**RAILWAY ORGANIZATION AND MANAGEMENT**, by James Peabody. Published by the La Salle Extension University, Chicago. 263 pages. Cloth.

This notable book, without question, fills a much felt vacuum. Mr. Peabody's long service as chief statistician of the Santa Fe system furnished him with excellent opportunities for collecting material for such a work, and he had the good sense in preparing the book for publication to extend his enquiries into the methods in vogue on other roads, with the result that all of the various departments of railroads are analyzed and presented separately. These embrace administration, operation, traffic, engineering, accounting as well as the numerous miscellaneous departments. Examples of typical organizations are also given. As is well known the uninitiated think that railroad organization is bound with too much red tape. They little know the essential requirements of the involved subject, and the multiplex duties necessarily falling upon the numerous departments. Properly to manage such vast undertakings requires the employment of many men of varied equipment. So vast is the range of subjects and so incisive the handling of them that the book before us may properly be called the most attractive general introduction to the business of railroading that has ever been published. It is indeed a text book in the science of transportation, and forms part of the material of the course of the university referred to in interstate commerce.

### Locomotives for Light Road Service.

The Baldwin Locomotive Works has just issued Bulletin No. 84, describing and illustrating locomotives for light road service on lines where comparatively light wheel loads must be carried. There are four types of these locomotives—the American (4-4-0), the Mogul (2-6-0), the Ten-wheel (4-6-0), and the Consolidation (2-8-0). The first is suitable for passenger service, the second for freight service, the third is adapted to either passenger or freight service, and the last having a heavier weight on driving wheels, is suitable for heavy freight service. In all 29 varieties are shown, ranging from the lighter type of Mogul with a total weight of engine and tender of 162,000 lbs., and a tractive force of 19,580 lbs., to the heavier type of Consolidation with a weight of engine and tender amounting to 310,000 lbs., with a tractive force of 43,000 lbs. A number of the engines are designed to use superheated steam. The brick arch is used where high volatile coal is employed as fuel. The application of these devices are determined after a careful study of the requirements of the service is made. All of them are admirably adapted for

work on short roads and branch lines. The largest of them can be safely used on rails weighing 70 lbs. per yard. A distinctive feature of these engines is the low sized driving wheels averaging 54 ins., to which their high tractive power at moderate speeds may be attributed. Some of them negotiate curves as sharp as 27 degrees, and grades as high as 6½ per cent per 1,000 feet. Copies of this interesting bulletin may be had on application to the Baldwin Locomotive Works, Philadelphia, Pa.

### Simplex Jacks.

Templeton, Kenly & Co., Chicago, Ill., have published Bulletin catalogue 216, showing the details of their improved jacks for steam and electric railroad, contracting industries and other purposes. As is well known the Simplex jacks possess advantages peculiarly their own. No other jack uses a chain to such a decided advantage in many emergencies. In quick service in cases of derailment it eliminates the necessity of calling for and waiting on the wrecking crew. The base generally being massive it is invaluable for field work as it may be readily anchored in any position. In brief it is a powerful jack that can be effectually used in the most trying conditions. It appears in many forms, and the mechanism of all is such that a load can never be dropped. All the internal parts are well secured from external dirt and dust. For complete particulars in regard to construction and uses send for a copy of the catalogue to the main office at Chicago, Ill.

### Prevention of Boiler Corrosion.

There are 32 pages of valuable matter and as many illustrations in a booklet issued by the Dearborn Chemical Company, Chicago, Ill., in regard to the incrustation, corrosion, foaming and other effects of water used in steam making and methods of preventing the same. The enterprising company has earned an enviable reputation for the success which they have achieved in the important department of water purification. The company does not deal in "cure-all" compounds. Their success has been achieved by water analysis and treatment. Each case is treated separately after a correct analysis of the conditions. The entire subject is a complex one even in its simplest forms. It does not follow that the services are high priced. Experience has perfected the methods and the analysis is invariably correct and the remedy gathered from the experience of 28 years is applied with gratifying results. The proper reagents change the character of the water and the remedy, as far as scientific research has been able to go, is accomplished. Send

# GOLD Car Heating & Lighting Company

Manufacturers of

**ELECTRIC,  
STEAM AND  
HOT WATER  
HEATING  
APPARATUS**

**FOR RAILWAY CARS  
VENTILATORS  
FOR PASSENGER  
AND REFRIGER-  
ATOR CARS  
ACETYLENE SYSTEM  
OF CAR LIGHTING**

Send for circular of our combination **PRESSURE AND VAPOR SYSTEM OF CAR HEATING**, which system automatically maintains about the same temperature in the car regardless of the outside weather conditions.

Main Office, Whitehall Building  
17 BATTERY PLACE  
NEW YORK

# Hydraulic

**Riveters Fixed and Portable  
Punches, Shears,  
Presses, Lifts, Cranes  
and Accumulators.**

**Matthews' Fire Hydrants,  
Eddy Valves  
Valve Indicator Posts.**

**The Camden High-Pressure Valves.**

## Cast Iron Pipe

**R. D. Wood & Company**

**Engineers, Iron  
Founders, Machinists.**

**100 Chestnut St., Philadelphia, Pa.**

## Nichols Transfer Tables Turntable Tractors

**GEO. P. NICHOLS & BRO.  
1090 Old Colony Bldg. CHICAGO**

## For Testing and Washing Locomotive Boilers

USE THE

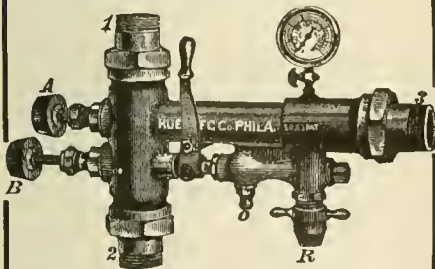

## Rue Boiler Washer and Tester

SEND FOR CATALOGUE

**Rue Manufacturing Co.  
228 Cherry Street Philadelphia, Pa.**

Manufacturers of Injectors, Ejectors,  
Boiler Washers and Testers, Boiler Checks,  
Check Valves.

for a copy of the booklet to the main office and be instructed.

### The Carburization of Coal.

The Powcecco Bulletin No. 2, contains a paper read recently at the eleventh annual convention of the Smoke Prevention Association at St. Louis, Mo., by Alonzo Kinyon, chief consultant of the board of engineering research for steam power production in locomotive operation of the Powdered Coal Engineering and Equipment Company, Chicago, Ill., in which the subject is discussed with a profusion of information in regard to combustion that is at once instructive and edifying. After a complete analysis of the subject Mr. Kinyon points out very clearly that the apparatus as now designed and controlled by the company provides for the mingling of the pulverized coal with the proper amount of air. This is commenced at the inception of the movement of the coal from the storage bin and continued and intensified up to the very instant of delivery to the furnace. When to this mingling of coal and air in transit is added the intensified mingling action in the carburizer, a condition is obtained at the moment of delivery which is ideal. Combustion is so complete and instantaneous that it amounts to a continuity of minute explosions that completely burn the coal and render every particle of heat available. The paper will well repay perusal, and copies may be had on application to the company's office at 1903 McCormick Building, Chicago.

### Automatic and Manual Systems.

A recent report issued by the Interstate Commerce Commission shows that of the 250,000 miles of railroad in the United States, there were about 85,000 miles operated under the block system. Of this total there nearly 25,000 miles automatic, and 60,000 manual. There is an annual increase of the automatic operation over the report of the preceding year of 7,500 miles.

### Anthracite Coal.

The report of the United States Geological Survey shows that during 1915 approximately 79,500,000 gross tons of anthracite coal were produced as against 81,000,000 in 1914. The average value at the mines was \$2.32, being practically the same for both years. There is an increased tendency for the smaller sizes to be used in domestic trade, thus cutting down the amount available for steam supply. The indications point to the gradual diminution of anthracite as a power plant fuel, and better provision made to burn satisfactorily a bituminous fuel.

### Labor Savers for Railroads.

Buckeye Catalogues E and D issued by the MacLeod Company, Cincinnati, Ohio.

contains more labor saving devices for railroads than we have space to enumerate. Among others there are portable oil burners, carbide lights, locomotive fire kindlers, sand blast outfits, flue welding machines, oil rivet forges, oxy-acetylene apparatus, portable weighing apparatus, oil and coal dust furnaces, weed burners and switch throwers. All have stood the test of time, and their growing popularity is the best proof of their applicability to the ends in view. All are fully described and illustrated. As an example the locomotive fire kindler may be referred to. It consists of a tank mounted on wheels and carries about twelve feet of oil and twelve feet of air hose. A burner is attached to the hose, and only three gallons of crude oil are used for each engine. The flame is applied below the grates, no wood being required, and the saving in time is about one-half. The appliance can be used for other purposes such as heating bent frames, locomotive tires, thermal welds, and for shrinking and expanding purposes. It is a money and time saver. The tire heaters are also marvels in their way, but the catalogues should be perused for details. Copies may be had from the company's office at 213 Pearl street, Cincinnati, Ohio.

### Railway Motor Gears and Pinions.

Several types of railway motor gears and pinions are manufactured by the General Electric Company, Schenectady, N. Y. These are fully described and illustrated in Bulletin No. 44,419. These embrace high quality cast steel untreated, and cast steel untreated both in split or solid types, as well as various forged steel types. Each has its particular field of usefulness, and selection must be governed to a great extent by local existing conditions. Extensive service tests have proved that all have shown the highest efficiency in point of durability, and the most economical combinations are those as recommended under each particular grade. Details are furnished how to order gears and pinions. All gears are bored to a finish. Improved methods of locking nuts and new devices in spring gears designed for heavy traction duty have been in service for the last two years, and the cushioning effect has been so beneficial that they are rapidly coming into general service. Among the new devices is a pinion puller consisting of a ring or puller designed in the form of an internal gear, and connected to a yoke containing the jack screw by two adjustable studs entirely preventing injury to the gear teeth. Comparative sizes of gear and pinion teeth are shown in detail and furnishes at once a complete epitome of a somewhat complex subject.

The bulletin should be in the hands of all interested and copies may be had on application to the company's office at Schenectady, N. Y.



## ASHTON POP VALVES AND GAGES

The Quality Goods That Last

The Ashton Valve Co.  
271 Franklin Street, Boston, Mass.  
No. 174 Market St., Chicago, Ill.

### Economy Devices.

A couple of interesting and instructive bulletins have just been received at this office. They are Nos. 111 and 112, Economy Devices Corporation, 30 Church street, New York. The first of these deals with the Straightway Piston Valve arrangement.

As designed for the ordinary piston valve cylinders, application of the well known principles governing the flow of gases has been put in practice. These principles are recognized as fundamental in the design of steam turbines, but are often ignored in the design of reciprocating engines. By properly directing the flow of steam to and from the valve, every square inch of the bushing port becomes effective. This permits the use of a valve only half the size commonly used, and, at the same time, facilitates the flow of steam to and from the cylinder to such an extent that the engine is noticeably smarter and faster.

It is not hard to convince any motive power man of the desirability of using the lightest possible valve. Large valves weighing from 225 to 300 lbs. produce stresses in valve stems exceeding 7,000 lbs., at high speeds, and this is greater in certain parts of the valve gear. At the same time, the matter of steam distribution has to be given careful attention. Steam pressure sufficient to produce an indicator card if it enter a port opening only 5/16 in. to 3/8 in. wide, is not properly effective, such an opening being no longer than the "snap shot" of an ordinary camera. Obstructions, cramped passages, sharp turns when they exist are there at the expense of the admission line. During the exhaust stroke, the expanded steam is forced out through the same passage, the port opening being only little wider and the period of time just a little longer. Properly designed ports relieve back pressure, which means many pounds added to tractive effort of the engine.

The second bulletin, No. 112, shows the Universal Valve Chest as applied to existing slide valve cylinders, so that superheated steam can be used without the need of applying new cylinders. The Economy Devices people say that "this is not an experiment, but is as fully perfected and standardized as the air brake. It has been adapted to every design of slide valve cylinder in service in the United States and Canada, and that the use of the Universal Valve Chest renders possible superheating slide valve engines almost as cheaply as those with piston valve cylinders, and renders these engines just as efficient, and as powerful, as the superheater engines."

The use of the smaller valves results in a minimum of frictional resistance and lowers the possible stresses of the reciprocating weights.

The valve chamber is designed to replace existing slide valves, and supply piston valves without change in cylinders. They are arranged for inside or outside steam pipes and may be used with existing valve gear or adapted to new outside gear. They are adaptable for use with self-centering valve stem guide. Either or both of these bulletins may be had by applying to the company at 30 Church street, New York, N. Y.

### Steam Grate Shaker.

An improved locomotive appliance is dealt with in bulletin No. 700, Series F, issued by the Franklin Railway Supply Co. of 30 Church street, New York, N. Y. The grate shaker consists of two cylinders, a control valve and connections between the cylinders and the grates. The cylinder in each case takes steam at one end which moves the piston. The piston and cylinder are open to the air in the centre and the two points of a double cone in the cylinder act upon a lever which gives motion to the grates. When steam is admitted to one end of a cylinder, the exhaust at the other end is open. The piston tight at each end is something, in principle, like the shuttle of a sewing-machine, but on the locomotive the operating lever for the grates takes the place of the shuttle-thread. The mechanism is readily applied to any locomotive, and it is intended to reduce time at terminals, increase time of service and so add to the earning power of the engine.

By the use of this ingenious mechanism fires may be kept clean on the road as there is a method of limiting the movement of the grates. This permits the "touching up," as one might say, of the grates so as to give the fire a gentle shake, without the fear of dumping it into the ash pan. A dull fire may thus get a new lease of life by loosening it up so that the air required for complete combustion may readily get at the glowing mass. Any section of grate, or a combination of sections or the entire grate may be shaken or "touched up" or completely dumped out as desired.

A glance at the bulletin which is illustrated puts the whole thing before a railroad man, and opens up the thought that a simple mechanical appliance designed to do a very necessary bit of work, has a tendency to make those who are benefited by it, extol it and thus insure its producing substantial results, and after all is said and done that is one of the many ways in which skilled workers are enabled to spell economy for the company they serve. The device entirely takes away from the fireman any necessity for great physical exertion, and as it works mechanically it does its work better than a man could possibly do it.

Write the makers of the device for the circular and see how you view the design and its purpose.

Statement of the ownership, management, etc., required by the act of Congress of August 24, 1912, of RAILWAY AND LOCOMOTIVE ENGINEERING, published monthly at New York, N. Y., for October 1, 1916.

State of New York } ss.  
County of New York }

Before me, a Notary Public in and for the State and county aforesaid, personally appeared Harry A. Kenney, who, having been duly sworn according to law, deposes and says that he is the Business Manager of the RAILWAY AND LOCOMOTIVE ENGINEERING, and that the following is, to the best of his knowledge and belief, a true statement of the ownership, management, etc., of the aforesaid publication, required by the Act of August 24, 1912, embodied in section 443, Postal Laws and Regulations, printed on the reverse of this form, to wit:

1. That the names and addresses of the publisher, editor, managing editor and business managers are: Publisher, Angus Sinclair Co., Inc., 114 Liberty St., New York, N. Y.; Editor, Angus Sinclair, 114 Liberty St., New York, N. Y.; Managing Editor, James Kennedy, 114 Liberty St., New York, N. Y.; Business Manager, Harry A. Kenney, 114 Liberty St., New York, N. Y.

2. That the owners are: Angus Sinclair Co., Inc., 114 Liberty St., New York, N. Y. Stockholders owning 1 per cent. of the total amount of stock: Angus Sinclair, 114 Liberty St., New York, N. Y.; James Kennedy, 114 Liberty St., New York, N. Y.; Harry A. Kenney, 114 Liberty St., New York, N. Y.; Mrs. O. J. Schanbacher, 40 Heddon Terrace, Newark, N. J.

3. That the known bondholders, mortgagees and other security holders owning or holding 1 per cent. or more of the total amount of bonds, mortgages, or other securities are: None.

4. That the two paragraphs next above, giving the names of the owners, stockholders, and security holders, if any, contain not only the list of stockholders and security holders as they appear upon the books of the Company, but also, in cases where the stockholder or security holder appears upon the books of the company as trustee or in any other fiduciary relation, the name of the person or corporation for whom such trustee is acting, is given; also that the said two paragraphs contain statements embracing affiant's full knowledge and belief as to the circumstances and conditions under which stockholders and security holders who do not appear upon the books of the company as trustees, hold stock and securities in a capacity other than that of a bona fide owner; and that this affiant has no reason to believe that any other person, association or corporation has any interest direct or indirect in the said stock, bonds or other securities than as so stated by him.

[SEAL] HARRY A. KENNEY,  
Business Manager.

Sworn to and subscribed before me this  
thirteenth day of October, 1916.

OLIVER R. GRANT,  
Notary Public.

You Want Tool Holders  
That Have Made Good



ARMSTRONG TOOL HOLDERS  
WERE AWARDED THE  
GRAND PRIZE

The Highest Possible Award at the Pan-  
ama-Pacific International Exposition  
THEY ALWAYS MAKE GOOD



ARMSTRONG BROS. TOOL CO.  
"The Tool Holder People"  
312 N. Francisco Ave., Chicago, U. S. A.

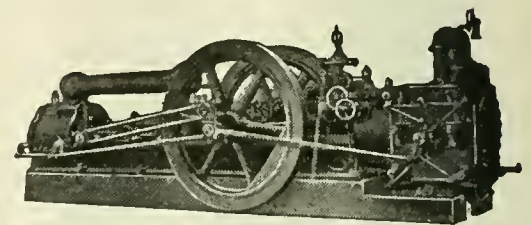

The Norwalk Iron Works Co.

SOUTH NORWALK, CONN.

Makers of Air and Gas Compressors  
For All Purposes

Send for Catalog



# Railway AND Locomotive Engineering

A Practical Journal of Motive Power, Rolling Stock and Appliances

Vol. XXIX.

114 Liberty Street, New York, December, 1916.

No. 12

## A New Design of Car Wheel Lathe

Pneumatic Elevating Device—"Sure Grip" Holder—Pneumatic Tool Clamps—  
Increased Weight of Machine—Greater Efficiency.

An improved car-wheel lathe of extra heavy design has recently been brought out by the Niles-Bement-Pond Company, of 111 Broadway, New York. This machine is of the open-center or end-driven type. In developing this machine the

much stiffer throughout, and this makes possible a far greater output. The weight of the machine has been so placed as to reduce vibration under the heavy cuts to a minimum, and the high speed steel tools used are capable of very heavy cuts.

the 8-in. journals which are now being used. The machine here described is the only one on the market that will take axles of this size. The largest diameter of wheels that the lathe will take is 44 ins. on the tread.

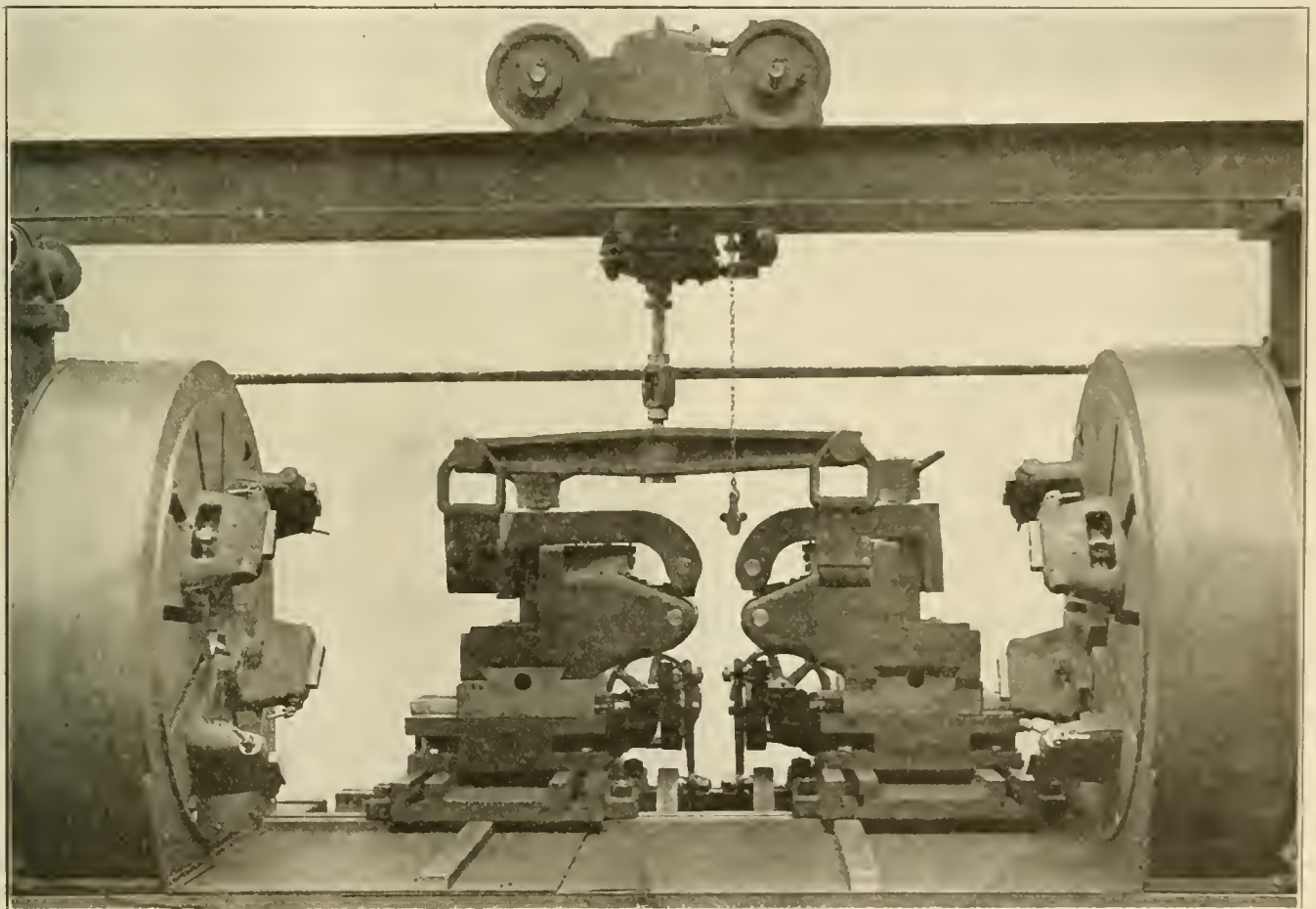

VIEW OF NILES-BEMENT-POND, NEW CAR WHEEL LATHE SHOWING PNEUMATIC ELEVATING DEVICE, PNEUMATIC TOOL CLAMPS, FACE PLATES AND "SURE GRIP" DRIVERS.

builders have kept in mind the latest requirements of car and locomotive shops. In the first place this new machine is considerably heavier than any of this type previously built. The result of this is the production of a machine which is

Of great importance to locomotive shops and certain car shops is the fact that this lathe will accommodate axle journals as large as 8 ins. in diameter. The machine can therefore be used for turning locomotive trailer wheels with

One of the most important new features of this new lathe is a quick-operating, powerful device, which enables the operator to instantly clamp the right-hand headstock by simply turning an air valve. The device is operated by a large

air cylinder, and it clamps the head to the bed simultaneously both at the front and back.

The right-hand headstock is equipped with power traverse of a new and efficient construction. The traverse is operated by an 8-h.p., separate motor placed at the end of the bed. The motor engages a large friction clutch, operated by a lever conveniently located so that the

the tools under the heaviest cuts. The wedge action forms a positive lock independent of the air pressure. Another feature that has proved of great advantage to operators is the magnetic push button control, which is furnished when the drive is by direct current. Two push button switches are situated near the carriages; one for starting and stopping the motor, and the other for slowing down

including the estimated number of journeys by season ticket holders, it was 1,591,000,000. The freight carried that year totaled 372,000,000 tons.

#### Equipment of the New York Central.

The New York Central has filed an application with the Public Service Commission in regard to the New York Central Trust of 1917. It proposes purchasing 4,000 steel box freight cars; 3,000 all-steel coal cars; 100 steel passenger coaches; 100 steel baggage cars; 30 multiple unit cars, and 10 electric locomotives. The estimated cost will be \$15,000,000.

#### Time Fuses of Great Britain.

The American Locomotive Company has received an order for 1,000,000 time fuses for the British Government, the contract providing for renewals at the option of the purchaser on another 2,000,000 fuses at the contract price. The order will be divided with the Westinghouse Air Brake Company, which company also shared the 2,200,000 fuse order placed with the locomotive company last summer and now nearly completed.

#### New Passenger Station at Newark, N. J.

A contract has been given by the Central of New Jersey to F. D. Hyde, New York, to build a new passenger station at Broad street, Newark. The building is to be 45 ft. high, 60 ft. wide in front and 266 ft. in the rear. The length will vary from 86 ft. to 400 ft. The structure will have concrete foundations, steel frame,

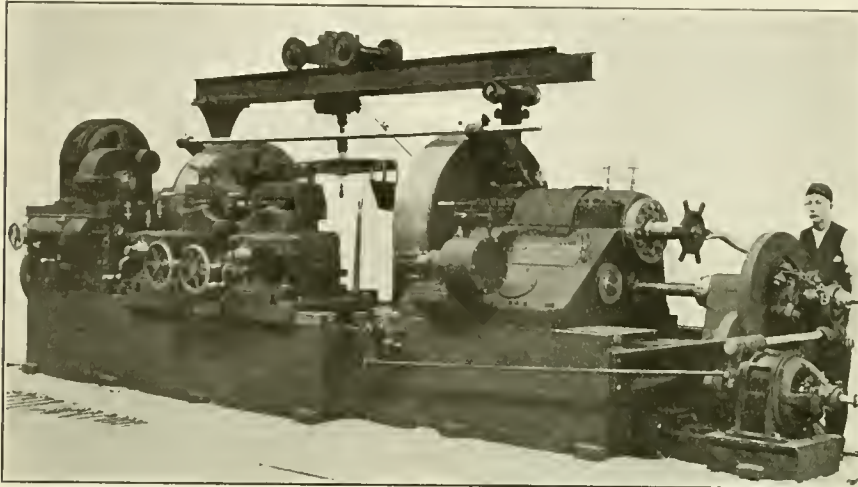

FRONT VIEW OF CAR LATHE WITH POWER TRAVERSE OF HEADSTOCK.

operator can traverse the headstock without leaving his position near the wheels. The friction clutch is so adjusted as to slip when excessive power is applied; this eliminates any possibility of damage to the mechanism in case the face-plate is brought up too forcibly against the wheels. There is no exposed gearing. The left-hand headstock is of the enclosed type, and contains the speed change gearing. The machine, which we have illustrated is equipped with alternating current drive. There are six speeds provided, which are changed by means of the handwheel and lever, which appear on our illustration, on the front of the headstock.

The face-plates are driven by internal gearing, which materially reduces the torsional strains on the main driving shaft, and provides a smoother drive, thus practically eliminating any chatter. This lathe is equipped with a simple and most useful calipering device by which the operator can readily mark both wheels to the same diameter. It consists of an adjustable pointer on a bar, which is rigidly supported on the headstocks, and has a sliding bearing in the right-hand bracket.

The tool rests, as on previous models, are equipped with patent pneumatic tool clamps. These have proved to be a most important factor in the great reduction in the time and labor of wheel turning that has been made on the Niles-Bement-Pond wheel lathes. The clamps enable the operator to make a change, and clamp the tools, all in a few seconds and without the use of a wrench. There is absolutely no chance of slipping or of vibration of

the speed when hard spots are encountered.

There is provided with the lathe an elevating attachment for lifting the wheels after they have been rolled into the machine. This consists of an overhead runway self-contained with the machine, and equipped with a pneumatic hoist.

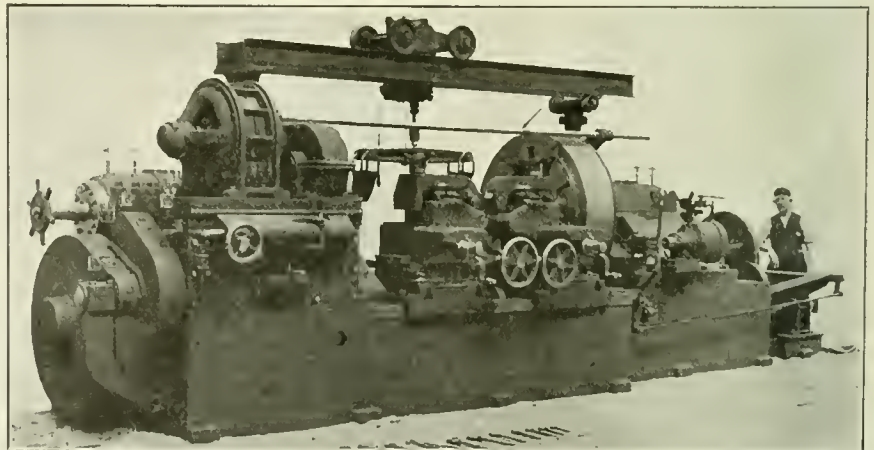

NEW CAR WHEEL LATHE SEEN FROM DRIVING HEADSTOCK (FRONT VIEW).

#### Bureau of Standards.

The Bureau of Standards of the United States Department of Commerce recently issued a bulletin on "Some Foreign Specifications for Railway Materials," in which it was said that British railways carried 3,000,000,000 passengers a year, and 520,000,000 tons of freight. The number of passengers we carry is about one-third of that given above—in 1913, by

brick and terra-cotta walls, wood and concrete roof, with built-up roof. The cost will be about \$550,000.

#### Reports on Block Signals.

It has been officially announced that on or before January 15, 1917, the railroads must file with the Interstate Commerce Commission reports of new block signal equipment.

# Twenty Locomotives for the Bessemer & Lake Erie

## Heavy Type of Freight Power With Most Approved Forms of Devices for Promoting Economy in Operation.

The Baldwin Locomotive Works has recently built, for the Bessemer & Lake Erie Railroad, twenty heavy locomotives of the 2-10-2 type, which constitute a notable group of engines for road work. With 332,700 lbs. on driving wheels and a tractive force of 81,600 lbs., the ratio of adhesion is 4.07. A ratio of approximately 4 has been found generally satisfactory

This boiler is equipped with a Street mechanical stoker, Franklin fire-door and grate shaker. This door is controlled by a pedal so located as to be conveniently operated by the fireman when he is firing the locomotive. Should the fire-door be open in case of a burst flue or dropped crown sheet the instant the fireman releases the pedal the door will close auto-

lever which gives motion to the grates. When steam is admitted to one end of a cylinder, the exhaust at the other end is open. The piston tight at each end is something in principle like the shuttle of a sewing machine, but on the locomotive the operating lever for the grates takes the place of the shuttle-thread. The mechanism is readily applied to any loco-

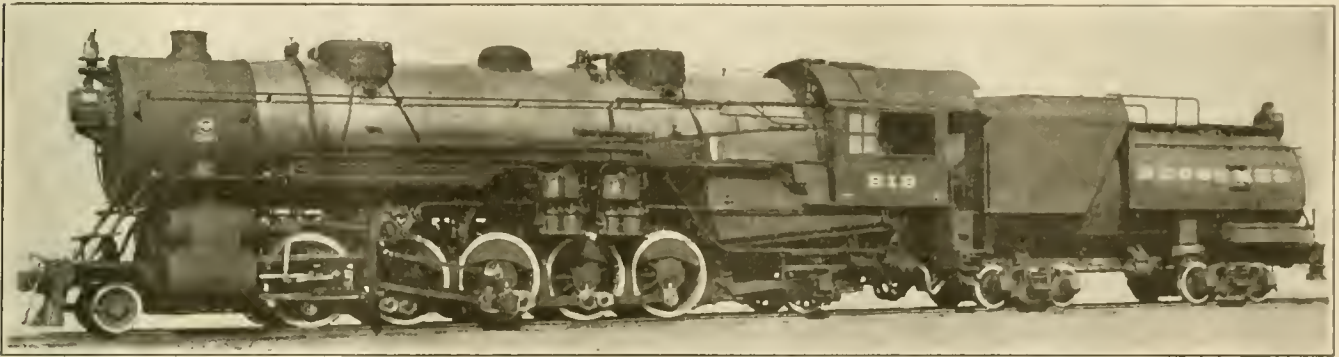

HEAVY FREIGHT 2-10-2 ENGINE FOR THE BESSEMER & LAKE ERIE.

G. M. Gray, Supt. Motive Power.

Baldwin Loco. Works, Builders.

for freight locomotives, as the weight on the driving wheels is then practically utilized for tractive purposes; and with reasonably careful handling, full tractive force can be developed without slipping. These engines traverse curves of 8 degs. on the main line, and of 16 degs. in yards.

The boiler used on this design is of high capacity, with a wide and deep fire-box which is placed back of the driving wheels and over the rear truck. The fire-box has a combustion chamber 65 in. long, and the tubes have a length of 21 ft. With this construction the tube length is well within the limits of good practice, and the furnace volume is large. The arch-tubes are five in number, and they extend from the throat to the back sheet.

The bending of the two outer arch tubes is for the purpose of clearing wash out plugs and the opening left for the plugs is well worth the time and expense of bending the tubes and putting them in, even if the work is awkward.

Flexible stays are used exclusively in the throat sheet and back-head, and in the breakage zone in the side sheets. Ten of these engines are equipped with Tait flexible staybolts, and the other ten engines have the American flexible stays. They also stay the entire combustion chamber, with the exception of the crown, where, at the forward end, three rows of Baldwin expansion stays are applied. The auxiliary dome is placed just ahead of the combustion chamber, and is mounted over an opening of sufficient size to permit entrance to the boiler for inspection purposes.

matically. This compels escaping steam to blow through the grates and front end and prevents it entering the cab. Some serious accidents have been averted by this door. Unless operated by the fireman it will not open, even if the engine turns over. Because of the quick closing feature of the Franklin fire-door, liability of running signals due to glare from the firebox is reduced.

motive, and it is intended to reduce time at terminals, increase time of service and so add to the earning power of the engine.

By the use of this ingenious mechanism fires may be kept clean on the road as there is a method of limiting the movement of the grates. This permits the "touching up," as one might say, of the grates so as to give the fire a gentle shake

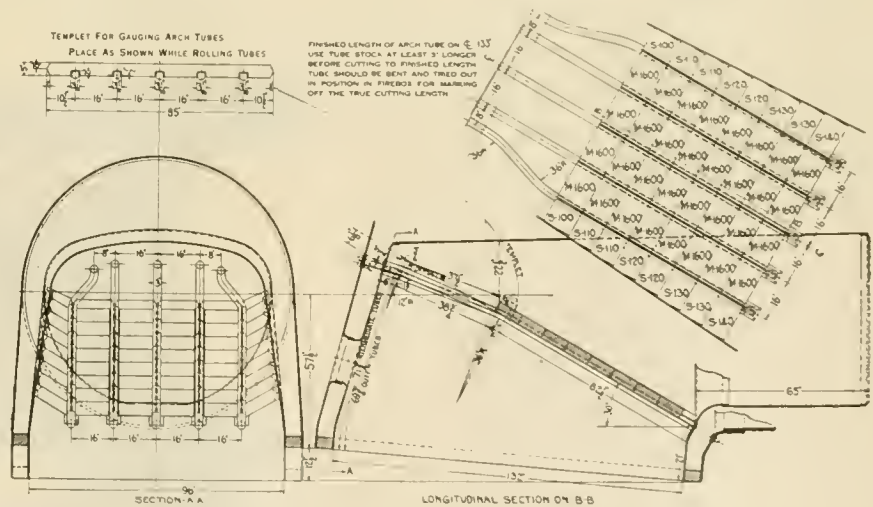

SECURITY FIRE BRICK ARCH USED IN B. & L. E. FREIGHT 2-10-2.

The grate shaker here referred to consists of two cylinders, a control valve and connections between the cylinders and the grates. The cylinder in each case takes steam at one end which moves the piston. The piston and cylinder are open to the air in the centre and the two points of a double cone in the cylinder act upon a

without the fear of dumping it. A fire may thus get a new lease of life by loosening it up so that the air required for complete combustion may readily get at the glowing mass. Any section of grate, or a combination of sections or the entire grate may be shaken or "touched up" or completely dumped out as desired. The

device entirely takes away from the fireman any necessity for physical exertion, and as it works mechanically it does its work better than a man could possibly do it.

vanadium cast iron. The pedestal shoes are of Hunt-Spiller metal.

The Franklin Railway Supply Co.'s automatic adjustable driving box wedge consists of an adjusting and a floating

bolt, which passes down through the binder and the spring bracket attached to the binder. An adjustable collar is mounted on the wedge bolt with a spring between the collar and the bracket, so that the tension of the spring holds the adjusting wedge in position and automatically takes up the slack. The floating or wear wedge fits between the adjusting wedge and the driving box and is almost as long as the distance between the binder and top of the jaw. When the box moves up or down the play allowed the auxiliary wedge will slightly relieve the wedge so that there is no danger of it becoming seized or "stuck." No attention is required other than the usual shoe and wedge oiling and the setting up of the spring nut when sufficient wear has accumulated to allow the main wedge to travel up  $\frac{3}{4}$  in.

The engines are also equipped with the Schmidt superheater, having 48 elements. The superheating surface is approximately 24 per cent. of the total water evaporating surface, the amounts being 1237 and 5191 sq. ft. respectively.

The main wheels have plain tires, and the equalization system divides between the second and third pairs of driving wheels, but the frames and spring rigging are so arranged that it can be readily changed, if desired, to divide between the third and fourth pairs. The equalizers and spring hangers are of open hearth hammered steel; the pins are fitted into hardened steel bushings, and are doweled in the hangers to prevent their turning.

The sand boxes are four in number, two for running ahead and two for backing up. To keep within the clearance limits, they are placed on the round of the boiler. For the same reason the

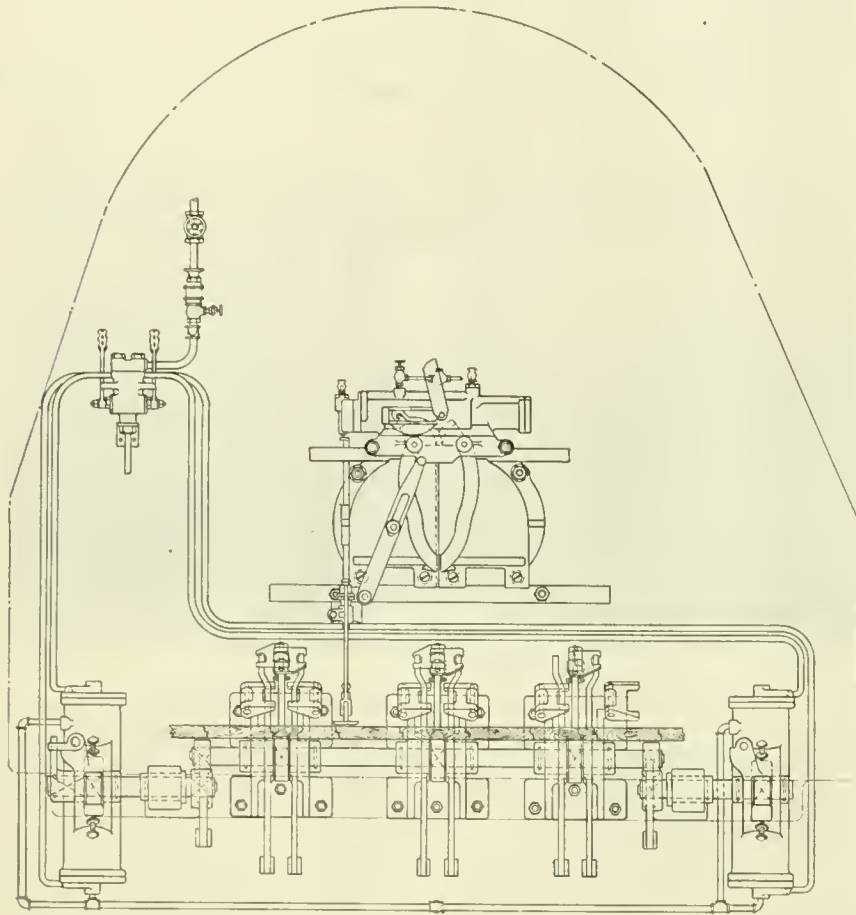

FRANKLIN FIRE DOOR AND GRATE SHAKER.

The steam distribution of the engine is 15 in. piston valves, which are set with a travel of  $6\frac{1}{2}$  ins. and a lead of  $\frac{1}{4}$  in. The valve followers and rings, steam chest and cylinder bushings, and piston bull rings and packing rings are made of Hunt-Spiller metal. The pistons have dished centres of rolled steel, with bull rings bolted on. The valve motion is of the Baker type, and the gears are controlled by the Ragonnet power reverse mechanism. This reverse mechanism is made by the Economy Devices Corporation. It was described in our November, 1916, issue, page 379. The reversing of a heavy locomotive, even under steam, is rendered as easy as the manipulation of the brake valve handle.

The main frames are vanadium steel castings, 6 ins. wide, placed with their centres 42 ins. apart transversely. The Commonwealth rear frame cradle is applied. With this construction the rear frames, foot-plate, equalizing beam fulcrums and other attachments, are combined in a single casting. Running gear details include the Economy front truck, Cole rear truck, Cole long main driving box, and Franklin adjustable wedges of

wedge. The adjusting wedge is tapered on one side to suit the taper of the jaw,

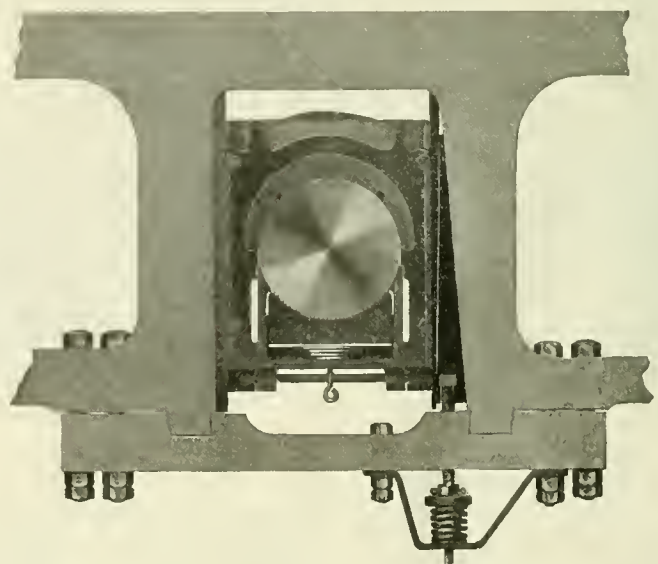

FRANKLIN AUTOMATIC ADJUSTABLE DRIVING BOX WEDGE.

and on the opposite side to accommodate the lesser taper of the floating wedge. To the adjusting wedge is attached a wedge-

bracket supporting the bell is mounted on the smoke-box front, and is where a head-lamp is usually placed.

The driving brake system is divided, there being separate pairs of cylinders for operating the brake shoes on the first three and the two rear pairs of wheels respectively. The equipment of the locomotive includes flange oilers on the leading drivers, and also a speedometer.

The tender is of the Vanderbilt type, with a tank 105 ins. in diameter. It has capacity for 10,000 gallons of water and 16 tons of coal.

The following table contains further particulars of these locomotives:

Gauge, 4 ft. 8½ ins; cylinders, 30 x 32 ins; valves, piston, 15 ins. diam. Boiler: Type, straight; diameter, 92 ins.; thickness of sheets, ⅞ in., 15/16 in., 1 in.; working pressure, 200 lbs.; fuel, soft coal; staving, radial. Fire Box: Material, steel; length, 132 ins.; width, 96 ins.; depth, front, 93¾ ins.; depth, back, 76¾ ins.;

21,950 lbs.; on truck, back, 49,000 lbs.; total engine, 404,250 lbs.; total engine and tender, 585,000 lbs. Tender: Wheels, number, 8; wheels, diameter, 33 ins.; journals, 6 x 11 ins.; tank capacity, 10,000 gals.; fuel capacity, 16 tons; service, freight.

**Chancetaker Necessitates the Wrecking Train.**

The night was raw and damp and the "stove" committee on the Interstate Railroad were hugging the steam pipes in the round house and were discussing general topics; in fact, mostly everything from the eight-hour law to the way General Foreman combs his hair. When in comes Bill Chance with an expression on his face as though he had lost his last pack of cigarettes.

Of course we all wanted to know what was wrong and why he had not gone out on the 1753 tonight. Finally, when Bill got a chance to speak, he told us why he had not gone out on his run and did not expect to go for several nights to come. In fact, he said he was a stay-at-home until every man at the Interstate round house had read and signed a paper which he pulled from his pocket. He said: "Last night, after getting engine 1753 ready to leave, I backed out of the round house. I thought the turntable was set for me. I kept on backing up 'till the first thing I knew the tender was in the turn-table pit and had demolished the shanty on the end of the turntable, injuring the turn-table motorman and also my fireman, who was fixing his fire at the time. As a matter of fact, the table was not set for me at all, but for the '65" on the track next to me. Of course I didn't think it was my fault. It was dark, steam was flying all around, and I could just about see the lights on the turn-table, and I thought it was set for me. Well, I had to report to the master mechanic on my arrival today and he, after hearing my statement, gave me a lecture that I will never forget. The master mechanic said: 'Young man, can you show me any good reason why you should not be dismissed? You thought the turn-table was set for you and without making sure you were right, you deliberately hacked into the pit, doing several hundred dollars worth of damage to the engine and turn-table, calling out the wrecker and blocking in a number of engines which had their trains waiting for them. And what is far worse, there were two men injured and it was certainly no fault of yours that the motorman was not killed and you arrested and held for manslaughter, and all through taking a chance and not being sure you were right before starting. Just stop and think about the serious offence you have committed. Your record here so far has been good, and I have decided that you are to take this paper, which has a full

account of this accident, and on it obtain the signatures of every man in the engine service at this terminal. I hope you will profit by this lesson which you have learned at such a dear price. And that it will be an object lesson to every man who reads this paper.'" "This," said Bill, "is only part of what the old man said to me and he sure had me thinking in a way I never did before. And I hope you fellows will all profit by this object lesson at my expense."

Everyone was ready to sign the paper, for in addition to the "story" of the mishap the master mechanic had put in some sort of acknowledgment on Bill's part that he was not only wrong, but needlessly wrong; that he knew it and acknowledged being a poor hand at the job. The "stove" committee read this part with joy and more than agreed with the strictures on his conduct, which Bill had been forced to acknowledge were fully called for. Bill was called a "poor fish" and similar names not redounding to his credit and honor were suggested by the men.

However, the smile of joy on the "stove" committee's faces deepened to a serious expression as each found that in signing he was made to acknowledge that he was not perfect and to renew his promises for eternal vigilance in the discharge of his own duties.

Thus was Bill's discomfiture made the subject of heart searching among his "friends," much to the profit of all concerned, and thus did "pitiless publicity" work for good among the men.

**Engineering Works in China.**

The Yangtze Engineering Works were established in Hankow in 1908. It is purely Chinese and under Chinese management. During 1915 it erected many railroad bridges for the Hankow-Schang railway. There is said to be an excellent opportunity for an American firm to handle railway equipment and engineers' supplies generally. The business of the firm is expanding rapidly.

**Adams-Bagnall Extensions.**

The Adams-Bagnall Electric Company of Cleveland, O., is now completing an addition to its factory with the installation of a complete vitreous or porcelain enameling plant. It is understood that this company will be the only manufacturer of electrical apparatus manufacturing porcelain-enameled, steel reflectors complete in its own factory.

**New Repair Shop on the C., B. & Q.**

A new locomotive repair and machine shop with necessary power house is being built by the Chicago, Burlington & Quincy at West Burlington at a cost of \$1,500,000. It is expected that the work will be ready for use by June, 1917.

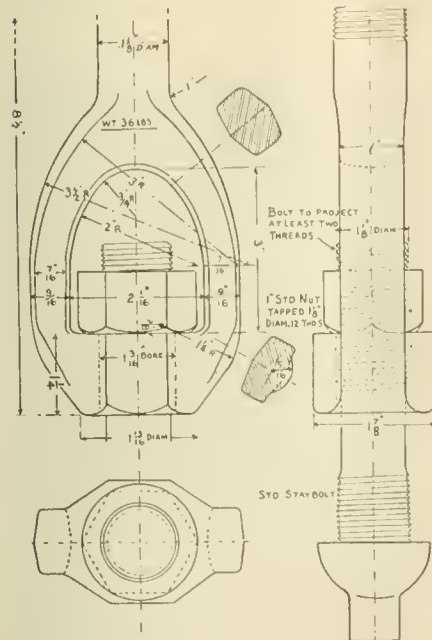

BALDWIN SLING STAY USED ON THE B. & L. E. ENGINE.

thickness of sheets: sides ⅜ in., back ⅜ in., crown ⅜ in., tube ⅝ in. Water Space: Front, 6 ins.; sides, 6 ins.; back, 6 ins. Tubes: Diameter, 5½ and 2¼ ins.; material, steel; thickness, 5½ ins., No. 9 W. G., 2¼ ins., No. 10 W. G.; number, 5½ ins., 48; 2¼ ins., 269; length, 21 ft. 0 in. Heating Surface: Fire box, 259 sq. ft.; combustion chamber, 129 sq. ft.; tubes, 4760 sq. ft.; firebrick tubes, 43 sq. ft.; total, 5191 sq. ft.; superheater, 1237 sq. ft.; grate area, 88 sq. ft. Driving Wheels: diameter, outside, 60 ins.; diameter, center, 53 ins.; journals, main, 13 x 22 ins.; journals, others, 11 x 13 ins. Engine Truck Wheels: diameter, front, 30 ins.; journals, 6 x 12 ins.; diameter, back, 42 ins.; journals, 9 x 14 ins. Wheel Base: Driving, 21 ft. 4 ins.; rigid, 21 ft. 4 in.; total engine, 40 ft. 7 ins.; total engine and tender, 77 ft. 8¼ ins. Weight: On driving wheels, 332,700 lbs.; on truck, front,

# Cleaning and Lubrication of Triple Valves

By W. V. TURNER, Assistant Manager, Westinghouse Air Brake Company

To questions arising concerning the cleaning and lubricating of triple valves, I wish to say that the remarks made by me at the Air Brake Convention at Atlanta, Ga., define my attitude in the matter, both as to the time of cleaning triple valves or other car brake operating valves and the elimination of oil and grease from any part or all parts of the valves. I might add that I have received a number of letters from officials of the operating departments of several railroads calling my attention to these same remarks, and stating that if car brake equipments could be successfully handled in the manner outlined, they were wasting enormous sums of money in the process of cleaning and lubricating triple valves.

In order that there may be no misunderstanding, I wish to state that a triple valve, control valve or universal valve should be cleaned as often as it becomes necessary, and it cannot become necessary so long as the valve is in a condition to pass the prescribed code of tests outlined for use with the standard test racks. For this reason my reply has been to allow the valves to run two, three or five years between periods of cleaning, if they will do so, and still be in a condition to pass a satisfactory test whenever it may be required.

The length of time the valves will run before it becomes necessary to remove them for cleaning will depend largely upon the character of the repair work that is done on them and the kind of lubricant that is used. It will also depend upon the amount of lubricant that is used in the brake cylinder and upon the amount of moisture that enters the valves through overheated locomotive air compressors or incorrect locomotive or yard test plant installations, but the dirt collectors will materially assist in preventing foreign matter in the brake pipe from passing into the triple valves.

Usually defective operation of triple valves occurs shortly after they have been cleaned, if oil or grease is used as a lubricant after they have been cleaned. After they are in service over six months there is less chance of trouble occurring and still less after they have been in service a year. The reason for this is, if you wish to catch a considerable amount of dust it is only necessary to spread some liquid around, and if there is any in the vicinity it will be collected by the liquid, and if you examine a triple valve that has been oiled and greased you will find a collection of dust. I do not say dirt; dirt is not shoveled into a triple valve. The substance found is merely a collection of dust, and if the liquid had not been present a considerable amount, if

not all of the dust, would have passed through the triple valve instead of having been collected. We clean the valve and again oil or grease it for the purpose of catching some more dust.

As to the time for removing the valve from the car for a test, this may be done every three, six or twelve months, and if the valve passes all of the prescribed tests it may be returned to service or be placed in stock in the storeroom, but obviously there will be no necessity for cleaning the valve or lubricating it if it passes the tests.

As to the tests, there are three commonly used: First, the manufacturers' test or repaired test, which determines whether or not the valve is in first class condition, a second one, having about 50 per cent. of the severity of the first, and a third, which if the valve fails to pass, it is condemned or proclaimed as requiring repairs. When and at what times these tests are to be made is a matter that best may be decided by each individual condition of service, but if there is nothing apparently wrong with a triple valve or car brake operating valve, and if it can be applied with a 4 or 5 lb. brake pipe reduction and released with a slow rise of from 2 to 3 lbs. in brake pipe pressure, as provided for with portable brake test trucks, why should the triple valve be removed for cleaning? Generally such valves are in a great deal better condition than they will be after they have passed through the cleaner's hands, not only because the inter-relation of parts will be disturbed, but often repairs are made that leave the valves in a much worse condition than they were before removal from the car.

It will not be necessary to dwell upon the general effects of frequent cleaning and lubricating of triple valves for the reason that so many serious disorders in brake operation have been cured by merely refraining from the cleaning of the valves, and I have recommended this to many different roads. On one electric road in particular where the brakes are being operated about 100 times as often as in ordinary steam road passenger service, the valves are never cleaned except when the car is in the shop, about once in a year, and I am pretty sure that at the present time the valve is not then cleaned if it passes the required tests.

I unqualifiedly endorse the lengthening of the time for cleaning triple valves; in fact, were it in my power, I would create a Master Car Builders' ruling that a triple valve must never be cleaned until such time as it fails to pass the M. C. B. tests, which would result in an improvement in valvular operation and save an enormous sum of money for the railroads. Think

how ridiculous it is to place a valve in service for three or six months, then remove and test it in strict accordance with the manufacturers' test, and if the valve fails to pass this 100 per cent. test, which it might do one week after construction or repairs, and then condemn the valve when it has undoubtedly from one to three years' perfect service left in it. The whole proposition reminds me of a housewife who dug up her rosebush every morning to see if it was taking root.

Obviously, I am writing this from the viewpoint of an air brake man rather than that of a manufacturer of air brake apparatus, or in either event I have only in mind the improvement in air brake operation, and when I first advocated the elimination of oil and grease from triple valve slide valves it was met with such a storm of protests that it was some years before the practice could be introduced, notwithstanding the fact that it could be proven at any time that it required just about twice as much force to move the triple valve slide valve when oiled or greased than it did when it was perfectly dry. I also advocated the same thing for the piston and packing ring. Can you imagine anything better than a little oil and dust for sticking a triple valve piston packing in the groove? I recommend testing the packing ring when dry or free from any kind of lubricant and allowing them to run dry afterward, but both recommendations coming at the same time was entirely too large a dose so that I was compelled to compromise or acquiesce to the use of oil in the triple valve piston bushing merely to satisfy a popular desire for a piece of foolishness. Anyone who has been interested enough to read this far will understand that almost any kind of a packing ring can be doctored with oil or grease so that it will deceive a test rack operator, but it is not for this reason only that the oil or grease should be eliminated; it is, as previously stated, for the purpose of preventing the collection of dirt in the piston lushing, and from causing the ring to become stuck in the groove.

It has been pointed out in your Air Brake Department that maintaining a triple valve slide dry involves the prevention of warm air or moisture from entering the brake pipe as well as a limiting of the amount of lubricant that is to be used in the brake cylinder. However, this will convey my ideas on cleaning and lubricating triple valves which are no longer considered radical, or even if so, a study of the Proceedings of Air Brake Association conventions will show that very frequently the radical suggestion of one year will become a recommended practice of the next year, and

likewise, the time is not far distant when the unnecessary cleaning of triple valves will be forbidden and the use of triple valve lubricant will be met with a well-deserved censure.

**Combined Hydraulic and Drill Press.**

By E. L. BOWEN,

AIR BRAKE FOREMAN, ILLINOIS CENTRAL RAILROAD.

The accompanying illustration is a reproduction of a photograph of a combined hydraulic and drill press for pressing and drilling connecting rod bushings. With a press of this type the brass bushings can be readily pressed into place and the grease and set-screw holes drilled expeditiously with a minimum of handling. The size of the hydraulic ram is 8 ins., and a standard air brake leather may be applied, and the pump itself is an old New York No. 2, with the piston cut off, and operates in cylinders of steel



EXPANDER PLUG, READY TO BE DRIVEN INTO PLACE.

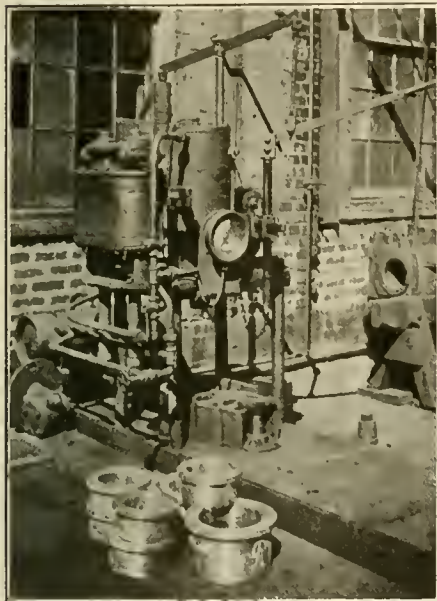

VIEW OF COMBINED HYDRAULIC AND DRILL PRESS.

tubing. The reservoir, shown at the back of the illustration, is connected to the water supply and has an air outlet pipe tapped into the top of the cylinder and attached to a three-way cock which, when the pressure is admitted, forces the ram down quickly upon the work pressing the bushing into place. The drill is driven by a 3½ ins. by 3½ ins. double oscillating air motor, and, as shown, has a lever movement. The introduction of this double-acting device has been a success in our shops, and saved much time and labor. Its construction is both simple and economical.

**Expander Plug for Stuffing Boxes of 9½ in. Air Pump.**

By F. W. BENTLEY, MISSOURI VALLEY, IOWA.

It is a well known fact that the stuffing boxes of the 9½-in. air pumps after a

period of service become somewhat worn and consequently smaller at the ends, owing, of course, to the repeated draw of the nut and frictional strain upon the threads. This, in time, considerably affects the security with which the nut can be drawn up against its gland, particularly in the case of metallic packing, and increases the growing liability of stripping. A considerable degree of trouble also commonly results from the causes referred to in procuring new or standard gland securely into place when the necessity for a change occurs of the inner bore or size of turned piston rods.

The reproduced photograph and sketch show the application of a very handy expander plug which drops into the box, and may be driven by a moderately heavy bar held through the rod opening in the other box. The plug is made with a slight taper and expands the box as much as is necessary at the top where it is worn or closed. This admits of the insertion of a new gland as well as enlarging the end of the box, admitting a

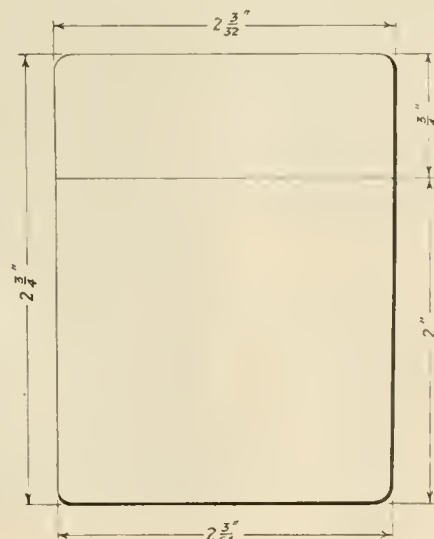

DETAILS OF PLUG, 3/64 TAPER IN 2 INS.

perfectly substantial draw of the box nut, and a tight fit of the entire length of the thread.

The idea of the device originated with Mr. F. W. Beck, air pump repair man here, and a great many boxes, which otherwise might have occasioned trouble at a later date, have been placed in perfect condition by the means of this easily constructed piece.

**Valve Testing Device.**

By J. A. JESSON,

LOUISVILLE & NASHVILLE RAILROAD.

As showing a quick and reliable method of testing valves the appended drawings show the details of a simple method which has been successfully put into operation here. Fig. 1 gives the dimensions of blocks A, used against the jaws of a vise between which a valve or other appliance to be tested is placed. An opening in the block suited to admit the ends of pipes admitting compressed through coupled pipe at C. Fig. 2 shows the completed appliance, and it will be noted that gaskets B are used to prevent

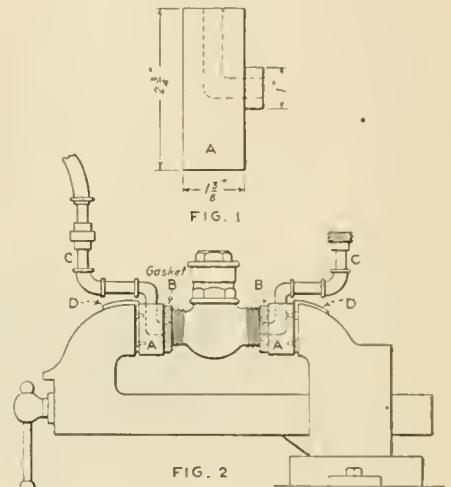

DETAILS OF TESTING DEVICE.

the escape of air between the blocks and the article to be tested. The vise clamps at D may be so constructed as to have protuberances adapted to suit notches in the blocks to keep them from slipping. The device precludes the necessity of numerous pipe connections, as by the use of quick-acting hose couplings the advantages of this method of testing valves will be at once appreciated. As a labor saver it is a success.

**The Wyman Drifting Device.**

By G. W. WYMAN, Delmar, Del.

Referring to questions asked by Mr. Byron Baker, Secretary Dominion Legislative Board, B. of L. E. concerning the Wyman Drifting Device I beg to give below the information he requested:

It is true that the matter of lubricating the steam chests and cylinder is one of the greatest importance and to successfully accomplish this, a properly designed

drifting device is absolutely essential. The consensus of opinion so far as we can ascertain is that the Wyman device meets all requirements.

Mr. Baker admits that the source of supply is correct and as to the method of conveying the steam to the steam chests would say that we have experienced no difficulty from condensation on the Eastern Railroads where we have this device in operation to a considerable extent, although the weather has at times been down to zero. However in installing this device in Canada where it is extremely cold throughout the entire winter would recommend that the pipes be covered with boiler preparation and drain cocks be installed to prevent freezing. If preferable the auxiliary pipe could be connected to the superheater unit side of header, and this would allow all steam to pass through units before reaching cylinders and would take care of all condensation that had accumulated in auxiliary pipe. While this is within the patent rights, we would not recommend the adoption of this as saturated steam is preferable while drifting in order to cool the cylinder and valve chamber.

As proof that this condensation does not interfere with lubricant and as Mr. Baker admits he gives from 5 to 6 drops for a 40-mile speed limit, we might say that we have experienced no trouble whatever in operating trains of 8 and 9 steel cars at 70 miles per hour on 3 and 4 drops per minute. This is evidence in itself that engine is thoroughly lubricated at all times.

#### Conditions in Alaska.

BY A RAILROAD BRAKEMAN.

In a recent issue of RAILWAY AND LOCOMOTIVE ENGINEERING an enterprising, young railroad man writing from Cordova, Alaska, stated that he was earning \$150 per month without overtime. Fearing that some of your readers might leave their homes for the far North, under light ballast in order to secure a full cargo of the legal tender, permit me to state the plain, naked truth that there are only two crews on the system of 196 miles that have anything approaching steady work all the year through, and they are guaranteed 26 days, or 2,600 miles per month. The brakemen receive 40 cts. per hour; that is \$4 per day of 10 hours or less, or 100 miles or less, which constitutes a day's work.

How your correspondent could earn \$150 per month without overtime would make interesting reading. We who are employed here would like to know. The pay for full time as stated is \$104, and with coffee at 25 cts., ham and cabbage at 50 cts., steak at 75 cts., and room rent at \$20 per month, and upwards. Other necessities are in proportion, especially laundrying, which is among the luxuries

of the wealthy. Then it may be thought by some that it is a long way from Piccadilly to Tipperary, but there is no doubt that it is a much longer way from the over-populated East to Cordova.

#### Force Feed Oiler.

BY H. KREISS, ELIZABETH, N. J.

In order to explain the merits of this oiler it will be necessary to explain some of the features of a hydrostatic lubricator so as to make it clear to the readers. The principle of the hydrostatic lubricator is the equalizing of pressures, plus a column of water under pressure of steam. In the body of the lubricator there is a water tube that is connected at the top of said body and also to the condenser. There is also an oil pipe that is connected to the oil passage at the bottom of said body which also connects the feeds. Oil being lighter than water floats to the top. So for every drop of water that enters

livery side of the feed nozzle. There will also be provision made to refill the glasses with water, all connections to the glasses will be separate and there will be no danger of forcing oil into the boiler. I also wish to mention there are no equalizing tubes.

#### Fuel Tests on a Locomotive.

One of the largest of the Mikado type of locomotives has been mounted on the locomotive testing laboratory of the Engineering Experiment Station, University of Illinois, for an extended series of tests. A co-operation arrangement has been made with the International Fuel Association and the United States Bureau of Mines to conduct tests with various sizes of coal used for fuel, and also with coal ground to very fine particles. Both hand and stoker firing will be used in the experiments. The testing laboratory is designed to permit the locomotive to be operated at any desired speed and at any

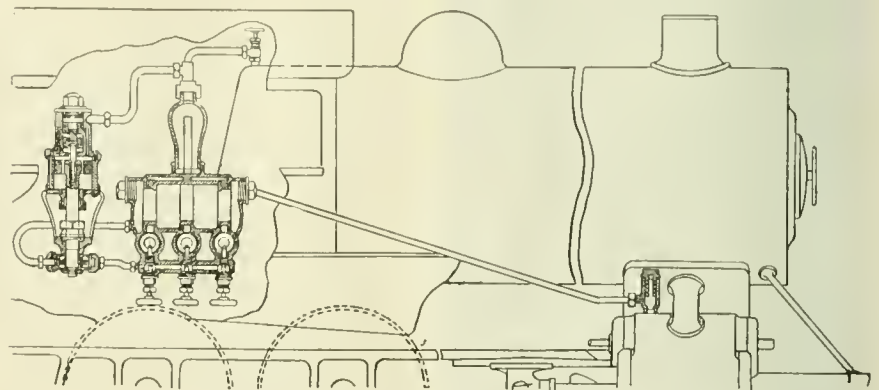

SECTION VIEW OF KREISS FORCE FEED OILER.

the body a drop of oil is displaced and forced through the feed nozzles and to the top of the water in the sight glass, then to circulate with the steam in the tallow pipe that connects the lubricator and the steam chest.

My reason for taking up the hydrostatic first is to show the readers that the only force that works lubricator is a column of water under pressure of steam providing the choke plugs and feed nozzles and also the tallow pipe are in good condition. My idea is to take and attach a small steam pump to a body of the same design, remove the water pipe and oil pipe and chokes and force the oil from the body through the glasses to the tallow pipe. Of course, the tallow pipe will have to be pumped full of oil before it will begin to force oil into the chest or cylinder. But you can readily see that my oiler will force the oil drop by drop into the chest or cylinder regardless of the pressure in same. There will be no pressure in the body, and will force the oil whether hot or cold. The advantage this oiler has is that you always have an excess pressure on the de-

power output under the same conditions as prevail in practice, while its performance is recorded by means of automatic equipment for measuring tractive effort, water consumption, fuel consumption, smoke production and other factors that will enter into the investigation. The locomotive is of the largest type used on the Baltimore & Ohio and has been loaned for the purpose.

#### U. S. Steel Corporation Increases Wage

A wage increase of 10 per cent, amounting to nearly \$20,000,000 per year, has been awarded by the United States Steel Corporation to the 191,126 employes, because of the increased cost of living. The announcement of the increase, which becomes effective this month, was made by Elbert H. Gary, chairman of the Board of the Corporation. This concern has the reputation of treating its men with due consideration, and acts on the theory expressed by the late Sir William Van Horne of the C. P. R. that contented employees are efficient employees.



# The Robinson Hose Connector

Air Brake, Steam and Signal Whistle Hose, Automatically Coupled

The idea in designing the vertical plane coupler was to remove the necessity for men going between cars during the act of coupling. The object of the Robinson connector is much the same. When cars are coupled, the uniting of air brake,

of a moment.

Its "hands," to still use this simile, are a pair of curved blades convex on the "business" side, their contours being formed to engage with each other, whether high or low or to one side or

cars below the couplers, and is supported by a bracket attached to a lug on each coupler. The connector rests against a rocking pin, placed parallel to the ties, and it can "give," in any direction when adjusting itself so that the hose may all come in line. The joints are kept tight by strong pressure behind them and this pressure is secured by the compression of a spring in rear of the rocking pin, for in the act of coupling, the whole device is carried backward, the rocking pin moving along a slotted hole in the connector, as the connector slides back. This gives about 900 to 1,500 lbs. pressure on the gaskets, which the connector has by that time brought into perfect alignment. This pressure is sufficient to hold the joints without even a whimper from internal pressure or by the jolt and jar of the moving train.

All one has to do is to couple the cars and by the same act, and by "the same token," the three hose sets are coupled up for keeps. No need for men to go between the cars and take time to connect the hose and see that the joints are tight. The thing is done and done properly, without loss of time or energy. There have been cases where a man has

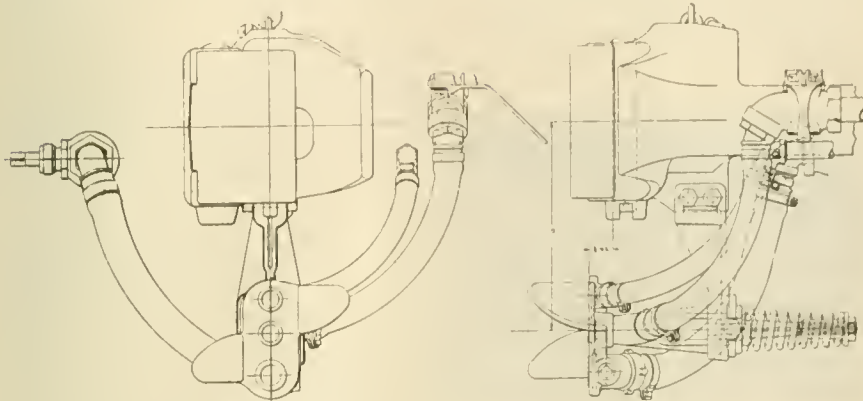

OUTLINE DRAWING OF THE ROBINSON CONNECTOR.

steam, and signal whistle hose, does not entail danger to life and limb, but it occupies time. The connector gathers these three kinds of hose up, as one might say, in its hands and unites them securely and permanently and does it without the loss

the other and slide "home" with ease and certainty. This device on the connector may not inappropriately be called the "gatherer," and when one of these meets another, the three sets of hose are guided to place and put strictly in line so that

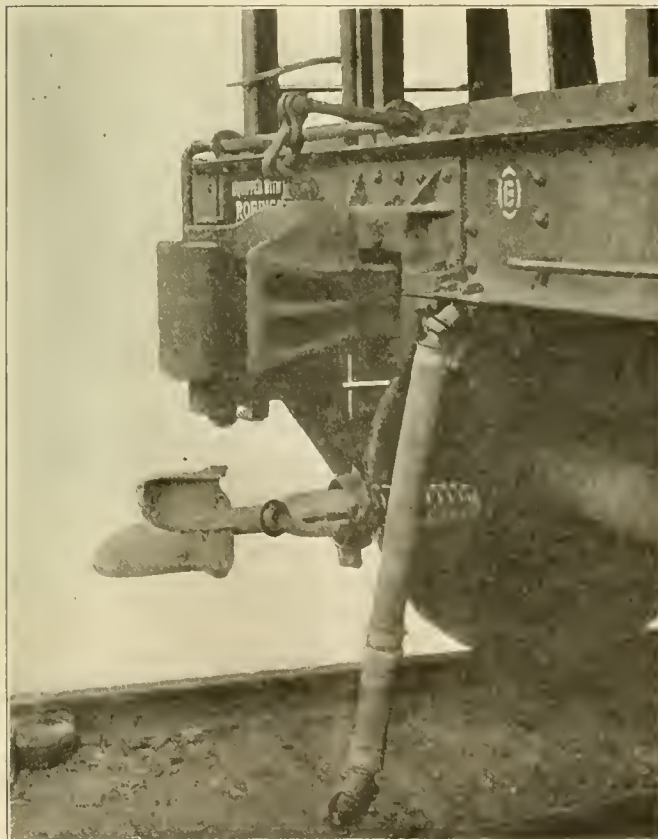

ROBINSON CONNECTOR WITH INTERCHANGE FITTING.

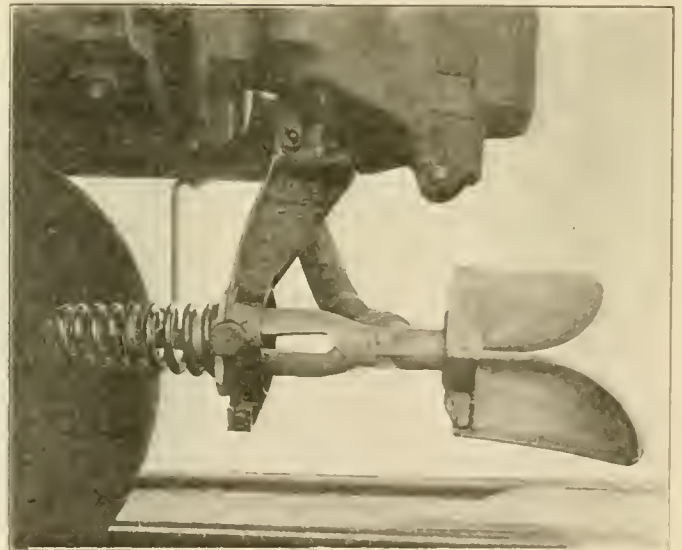

ROBINSON CONNECTOR READY FOR USE.

there is a full port opening, each to each, as they should be and as they are. Where freight cars are concerned the steam hose is absent.

The connector hangs between the

coupled an air brake hose to a signal hose. It ought not to be done, and in many cases it cannot be done, yet like the exception that proves the rule, it has happened before now, but not where the Robinson connector has been permitted to do the business. Automatic action occasionally triumphs over the intelligent machine called man.

If a car equipped with the Robinson connector meets one not so equipped,

all that is necessary is to disconnect the hose near the "gatherer," and apply a short length and regular coupling so as to "get round" the connector. The short hose is attached by what is called a bayonet joint. This has parallel lugs and spaces, and derives its name from the way a bayonet was in former days secured to the muzzle of a rifle. It, in a way, now resembles the interrupted thread in the breech block of a large field gun. The gasket, which the bayonet joint holds tight, is a rubber ring with convex surface outside and a half-moon groove cut out of the inside.

Compressed air inside the hose and joints fills the half-moon groove and forces the edges outward so that it fits air tight on the joint and all is well. A bayonet joint can be made in "less than no time" by anyone, skilled or unskilled. Men with mits on, in cold weather, can do it, and when made is "all to the good."

The whole apparatus weighs about 35 lbs. and this matter of automatically doing a man's job, insures safety, reduces time, and avoids possible mistakes, as it does, and is very well worth looking into at least. The Robinson Connector Company, of Branford, Conn., has placed the device on the market and it has met with a good deal of very gratifying success.

Coupling two cars together insures the simultaneous coupling of the attachments. This device is the logical outcome of the vertical plane coupler idea and it works with it as far as surety and time are concerned, and it holds very tightly while the cars remain coupled, and it disconnects easily and without a hitch when the cars are parted.

The connector has been used very extensively in Canada and its use is being extended on two of the principal railways of the Dominion. The trials upon which lately placed orders have been based, have been very severe and the good opinion it has produced among practical railroad men is founded solely on performance. The rigors of the Canadian winters where snow and ice cover and clog all equipment and intense cold searches out weak spots, if there are any, have not put the Robinson Connector out of service nor disqualified it in any way. The Canadian Northern and the C. P. R. are both using the connector with satisfaction and the Virginian railway, probably with opposite climatic conditions, find the device most serviceable for their needs. Thus the connector has demonstrated its usefulness in mild and balmy weather, and in the hard, cold, persistent snows of the Northland.

#### Air Brake Association.

Mr. F. M. Nellis, Secretary of the Air-Brake Association announces that Memphis, Tenn., has been selected by the Executive Committee of the 24th Annual Convention of the Association to be held May 1-4, 1917.

## Steel Underframe Baggage Cars for the Intercolonial Railway

Cars with Doors Closer than Usual—Steel Trunks Used—Equipment for the "Ocean Limited"

The Intercolonial Railway of Canada has recently built four steel underframe baggage cars at their Moncton, N. B., shops, where the superintendent of motive power, our old and valued friend Mr. Geo. R. Joughins, lives. These cars will be used on one of the best passenger trains on the road, the Ocean Limited. Two mail cars of the same type are be-

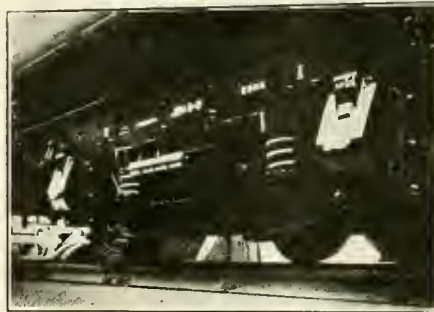

I. C. R. SOLID STEEL TRUNKS.

ing built at the shops, which when completed will be used on the same trains.

The baggage cars have solid steel trucks, and are practically the same as were designed by Mr. R. W. Burnett at the time that he was master car builder on the Canadian Pacific Railway. The wheel base of the trucks is 8 ft. The

these cars so that they can be stopped in shortest possible distance without skidding the wheels.

Another feature which may be mentioned is that the side doors are placed closer together than usual to permit of the through baggage or express to be loaded in either end of the car, and the floors are covered by hard pine or other hard wood strips, which dispenses with the fish rack, thus allowing the floor of the car to be kept clean and sanitary, especially when the cars are used for fish shipments.

An order to build a larger number of this type of cars is expected at Moncton. The cars are 64 ft. 8 $\frac{5}{8}$  ins. over the buffers. Each door is 5 ft. wide, separated by a space of 10 ft. 8 ins. and along this wall on each side the "vitals" of the car are grouped. A drop desk for the baggageman is near one door. Beside the desk is a fire extinguisher and hose rack, a loading plank, and a flat wall-box filled with emergency tools. The space between doors on the other side of the car carries a gas mantle box, the air signal valve and the conductor's valve. The car itself is 8 ft. 10 $\frac{3}{8}$  ins. inside width, and the end doors have an opening 2 ft. 2 ins. wide. The car is a good piece of work and has been turned out by men



BAGGAGE CAR FOR THE INTERCOLONIAL RAILWAY OF CANADA.

truck transoms are steel and are reinforced by wide gusset plates which unite transoms and truck sides in a very substantial way.

The draft gear is the latest form of Miner friction gear designed to absorb the shock in starting and stopping of train, and is of sufficient strength to withstand the strains caused when the heaviest type of engine is used. The latest type of Westinghouse brake equipment is on

not specially trained to the building of large passenger train equipment.

#### Use of Leather Belts.

It is good practice to have the hair side of the belt next the pulley. It is harder and more liable to crack than the flesh side, and being harder and smoother it will run smooth with less slip than the flesh side. The tendency to cramp or compress will be less in running over the pulley when run in this way.

# Convention of Traveling Engineers Association

## Summary of Work Done at Twenty-fourth Convention—Reports and Discussions Thereof

During the years 1891 and 1892 traveling engineers and other railroad men fell into the habit of visiting the office of *LOCOMOTIVE ENGINEERING* for the purpose of discussing current locomotive news and problems that were becoming prominent through the pages of *LOCOMOTIVE ENGINEERING*.

On November 13, 1892, a preliminary meeting of traveling engineers was held at Chicago for the purpose of considering the question of organizing a Traveling Engineers' Association, having for its objects and aims the improvement of the locomotive engine service of American railways through the advancement of knowledge concerning the duties of traveling engineers by discussions in common and the exchange of information on subjects interesting to the members. There were fourteen traveling engineers at this meeting. They finished by calling a meeting of traveling engineers in the office of *LOCOMOTIVE ENGINEERING*, New York. Messrs. Clinton B. Conger, W. O. Thompson and Donald R. McBain were the leading spirits at the meeting. Mr. Conger was elected president, and Mr. Thompson secretary.

What may be considered the first convention of the Traveling Engineers' Association met in the office of *LOCOMOTIVE ENGINEERING* on January 9, 1893. Mr. Conger was elected president and Mr. Thompson secretary. The principal part of this convention was devoted to organization and the arranging of subjects of investigation for future meetings. An important function was a dinner at the Engineers' Club provided by the proprietors of *LOCOMOTIVE ENGINEERING*. The number of members enrolled up to this time was 48 active and 5 associate members. At the second convention 96 active and 20 associate members were reported to be on the roll. The organization has steadily increased in numbers, till now, when at the opening of the 24th convention held in Chicago last month the secretary reported that the association has a total membership of 1,056.

### TWENTY-FOURTH CONVENTION.

The 24th annual convention of the Traveling Engineers' Association opened in the Hotel Sherman and lasted four days. President J. K. Scott, assistant superintendent of locomotive performance of the St. Louis & San Francisco, presided. There was a very large attendance, the reports presented were excellent and the discussion thereon the finest we have ever listened to. After some preliminary business came the address.

### PRESIDENT'S ADDRESS.

He said that the principal aim of the association is educational. Those men most capable of training the engineers of the country are selected for traveling engineers, and they are celebrated for the efficiency of their work. He dwelt some time on the educational advantages derived from studying the exhibits displayed in convention, and urged the members present to make good use of the opportunity open to them.

Railroad supplies have risen in price owing to the war in Europe, and wages have also risen, putting a heavy burden upon railroads. In order that we may do our part to assist in relieving this unusual strain, we as traveling engineers should zealously guard the machinery, fuel and supplies under our charge, that the best possible use may be secured from them. More skillful operation of the locomotive on the road, and increased efficiency in the handling of trains are matters that will tend to reduce cost of operation. Therefore, we should give our attention and special effort to bring locomotive operation to the highest possible standard of economy and good service.

He referred to the threatened strike of trainmen as an averted calamity beyond words to express. He called for greater preparedness against strikes by passing national laws to protect the 100,000,000 of people, who would suffer through interference with their transportation facilities, their properties and industries.

High commendation was given to Secretary W. O. Thompson for the highly efficient services he performs for the association.

### MECHANICAL STOKERS.

A committee's report on the above subject was presented under the title: "What effect does the mechanical placing of fuel in fireboxes and lubrication of locomotives have on cost of operation?"

The first portion of this report was made by a committee of which W. L. Robison, of the Baltimore & Ohio, was chairman. He said this report will be merely an endeavor to record some fact which may be classed as affecting the conducting of transportation expenses of railroads. Of this, fuel expense representing approximately 25 per cent., the managements depend largely upon us to supervise, and see that locomotives are in such condition, so equipped and handled that as near as possible the maximum rated capacity will be maintained.

The feeding of fuel into locomotive fireboxes, by mechanical means has passed

the experimental stage, and locomotives are operating at a mechanical efficiency of from 85 to 100 per cent., hauling trains and effecting operating economies that would not be possible under ordinary hand-firing conditions.

The application of appliances for firing solid fuels mechanically had made little headway until during the year 1912, when about 200 installations of various designs had been applied, since which the number has been increased on the railways within the United States to about 1,900 at the present time, and the field developing and extending.

Apparently the principal reasons for the small progress in equipping locomotives with means for firing fuel mechanically made prior to four years ago may be summarized about as follows:

1. Size of locomotives, particularly regarding grate area and tonnage hauled per train, which did not make it essential.
2. Lack of any assurance that it would be possible to fire a locomotive with any degree of economy as compared with hand firing.
3. Failure to give proper consideration to fact that large locomotives so equipped could be operated nearer their maximum capacity.
4. No indication that less expensive fuel could be used than with hand firing.
5. Appliances with which experiments had been made not suitable in one or more particulars to meet the variable factors of fuel, locomotives and operating conditions.
6. Impossibility of dispensing with the regular locomotive fireman and substituting less expensive labor.

The average tractive power of all locomotives in the United States has increased in past 10 years 38.6 per cent., the heavy locomotive of years ago ranging from 36,000 to 42,000 pounds having given place to those ranging from 54,000 to 160,000 pounds, and the figures increasing yearly. The average tons handled per freight train has increased 54.1 per cent. in 10 years.

With the introduction of larger power units and resultant increased train load, various means were introduced to secure the rated maximum capacity of the locomotives, such as brick arches, superheaters, etc., but the amount of coal consumed by a locomotive for a trip remained stationary or increased, resulting in some roads using such heavy power experiencing serious difficulty during the summer months in retaining experienced firemen in service, and securing new men of the

caliber that it could be expected would later develop into proper material for promotion to engineers. Therefore, if the heavy tonnage trains on the roads in question were to be success, and the cost of operation held to a minimum, the necessity for the "iron fireman" was apparent.

The following figures covering the four railways using the largest number of locomotives with appliances for feeding fuel mechanically, and by which a large proportion of their freight traffic is handled, show interesting comparisons of average train loads. (Figures taken from reports made to the Interstate Commerce Commission):

FISCAL YEAR ENDING JUNE 30, 1915, COMPARED WITH FISCAL YEAR ENDING JUNE 30, 1904.

	Inc. Avg. Tractive Power.	Inc. Avg. No. Tons Frt. Per Train load.
Road A .....	43%	78%
Road B .....	40	72
Road C .....	30.7	72
Road D .....	29	54

(The locomotive fuel cost per ton mile on each road shows a decrease for 1915 as compared with 1904.)

The advantages of using mechanical stokers over hand firing are reported to be: 1, increased tonnage; 2, increased speed; 3, saving of labor of fireman; 4, elimination of necessity for second fireman; 5, elimination of necessity for shoveling coal ahead by laborers at intermediate points; 6, reduced necessity for shaking grates; 7, firemen follow engines more regularly; 8, reduced number of engine failures; 9, ability to run freight trains long distances; 10, smoke prevention; 11, use of inferior grades of coal; 12, improved consumption of fuel; 13, maximum pressure of steam more easily maintained.

Concerning the use of powdered fuel the committee said the results were:

1. Smokeless, sparkless and cinderless operation.
2. Maintenance of maximum boiler pressure with a uniform average variation of 3 pounds without popping.
3. An increase of from 7½ to 15 per cent. in boiler efficiency as compared with burning lump coal on grates.
4. Saving of from 14 to 30 per cent. in fuel of equivalent heat value fired.
5. Enlarged exhaust nozzle area, resulting in greater draw-bar pull and smoother working of locomotive.
6. Elimination of ash pit delays facilities and expense, and reduction in time required for and ease in firing up.
7. Maintenance of a relatively high degree of superheated steam.
8. No accumulation of cinders, soot or ashes in superheater or boiler flues, smokebox or on superheater elements.

9. No punishment of or overheating of firebox, new or old sheets, seams, rivets, patchbolts, stays or flue heads.

10. Elimination of arduous manual labor for building, cleaning and dumping fires, and for firing.

11. Avoids expense and annoyance for providing various sizes and kinds of fuels.

12. Eliminates the necessity of front end and ash-pan inspection, and for special fuels, firing tools and appliances for building fires, and for stoking and cleaning fires.

13. Equal provision with engineer for fireman to observe signals and track, thus reducing liability of accident.

"Your committee is of the opinion that the effectiveness and utility of fuel in pulverized form has been demonstrated from the past years' development, and that the progress in the use of this method of stoking and burning bituminous and anthracite coals and lignites for generating power, heat and light on railways, will be quite marked from now on."

GENERAL SUMMARY.

The capacity of the power unit is largely dependent upon that of the boiler. With the increase in size of the locomotive, in the case of many new types the boiler has had to be enlarged to the extent of over-reaching the limitations of hand firing, clearly indicating the necessity of introducing the fuel into the firebox by mechanical means. In fact, locomotives have within late years been constructed, the building of which would probably not have been attempted had not the practicability of this means of handling the fuel been established. There is little doubt that many locomotives are in service, the maximum capacity of which is not being obtained, due to the limitations in connection with the ordinary methods of manual firing on grates.

In order to obtain the resulting operating savings, the managements of most roads are constantly endeavoring to increase the train load. Therefore, if large locomotives are required, it would certainly not be economical to attempt to fire them by hand, providing that by so doing their capacity could not be utilized to the fullest extent.

The committee on this subject was W. L. Robinson, B. & O.; E. Hartensten, C. & A.; J. H. De Salis, N. Y. C.; M. J. McAndrew, M. C.; E. A. Averill, Locomotive Feed Water Heater Company.

DISCUSSION.

J. H. De Salis said that on the Pennsylvania division of the New York Central there are 15 Mallet and one Consolidation engines equipped with mechanical stokers and superheaters. The engine crews are assigned to the engines, and they follow the engines better and take more interest in their work than those on hand-fired engines. Many of the fire-

men prefer stoker-fired engines than passenger engines. The train tonnage has been increased from 3,600 to 3,900 with the stoker-fired engines.

F. P. Roesch: On the El Paso & Southwestern there is a long pull of 117 miles with one per cent. grade, and another one per cent. grade of 38 miles. In hot weather it has been found necessary to reduce the tonnage on hand-fired engines, but the stoker engines are loaded to full capacity. While more coal is used by the stoker engines, it costs only \$2.10 per ton, as compared with \$4.65 for the coal used by hand-fired engines. It is now proposed to put stokers on some passenger engines, which are required to haul 14 steel cars over the long one per cent grade.

A. W. Willsie said that the stoker engines on the Burlington use screenings that pass through two-inch round hole screens. It has been found that coal prepared on a round hole screen will be distributed better by the stoker than when it is prepared through shaker bars.

SMOKE ELIMINATION.

More real progress in smoke abatement has been made in this country the last five years than had been made in 50 years previous to this period. This great and permanent advancement was obtained through the executive heads of the railroads taking hold of the question. To some extent this was forced on them by legislative action, which in many cases was unreasonable. The smoke problem is a question of perfect combustion. The nearer we come to it the nearer we are to smokeless operation, but when the varying conditions under which a locomotive is operated are considered it is not an easy matter. At times it is necessary to burn as high as 150 pounds of coal per square foot of grate surface per hour, a condition that few combustion engineers ever consider in advocating smokeless operation. There are cases where the engine crews are not responsible for smoke violations. One of these is where the power is in poor condition, but the great majority of these cases were caused by carelessness of the engine crews.

There is no question but that seniority as conducted today, encourage this class of men, and is an injustice to the man who takes a pride in educating himself and doing things the best he knows how. On the other hand, those of us who are old enough to have worked under conditions existing before seniority became general, still believe it to be a lesser evil than favoritism. One thing that could be done without affecting senior rights would be to make a record of the men at stated periods. This would be along the lines followed some years ago on many roads when each engineer received an individual performance sheet monthly, showing the number of miles made by

his engine, the cost for fuel, oil and repairs, the engineers' and firemen's wages, wipers' wages, average cost per hundred tons per mile, and all details pertaining to the operation and maintenance of their engine. It would in our opinion result in saving the present cost of supervision needed to keep smoke elimination within the limits required.

Perhaps the nearest approach to smoke elimination in the operation of locomotives will come with the use of powdered coal, now being experimented with on several railroads. The use of powdered coal will afford a more perfect combustion of the fuel than is otherwise

W. H. Corbett said that on the Michigan Central, in cases of a second violation, the offender is given a suspended sentence of five days, which is held over him for one year. The brick arch and steam jet smoke consumer give excellent results.

C. W. Corning: We find on the Chicago & North Western that when firing up a cold engine, by placing the coal on the grate and covering it with kindling, such as edgings from the mill, and igniting it with waste saturated by coal oil, a fire can be started with little smoke. The engines must be maintained in good condition for smokeless operation.

comments upon the pyrometer, drifting valve, brick arch, mechanical stoker, grates, coal passer as applied to tender, automatic fire door, power reverse gear and flange oiler.

The principal portion of a very voluminous report was devoted to superheaters. The fire-tube superheater, they said, has come to be almost universally considered as an essential part of the locomotive. The economy it affords is recognized, and it is, without doubt, one of the most important factors in the development of the locomotive, in that it has been largely responsible for the larger locomotives of today.

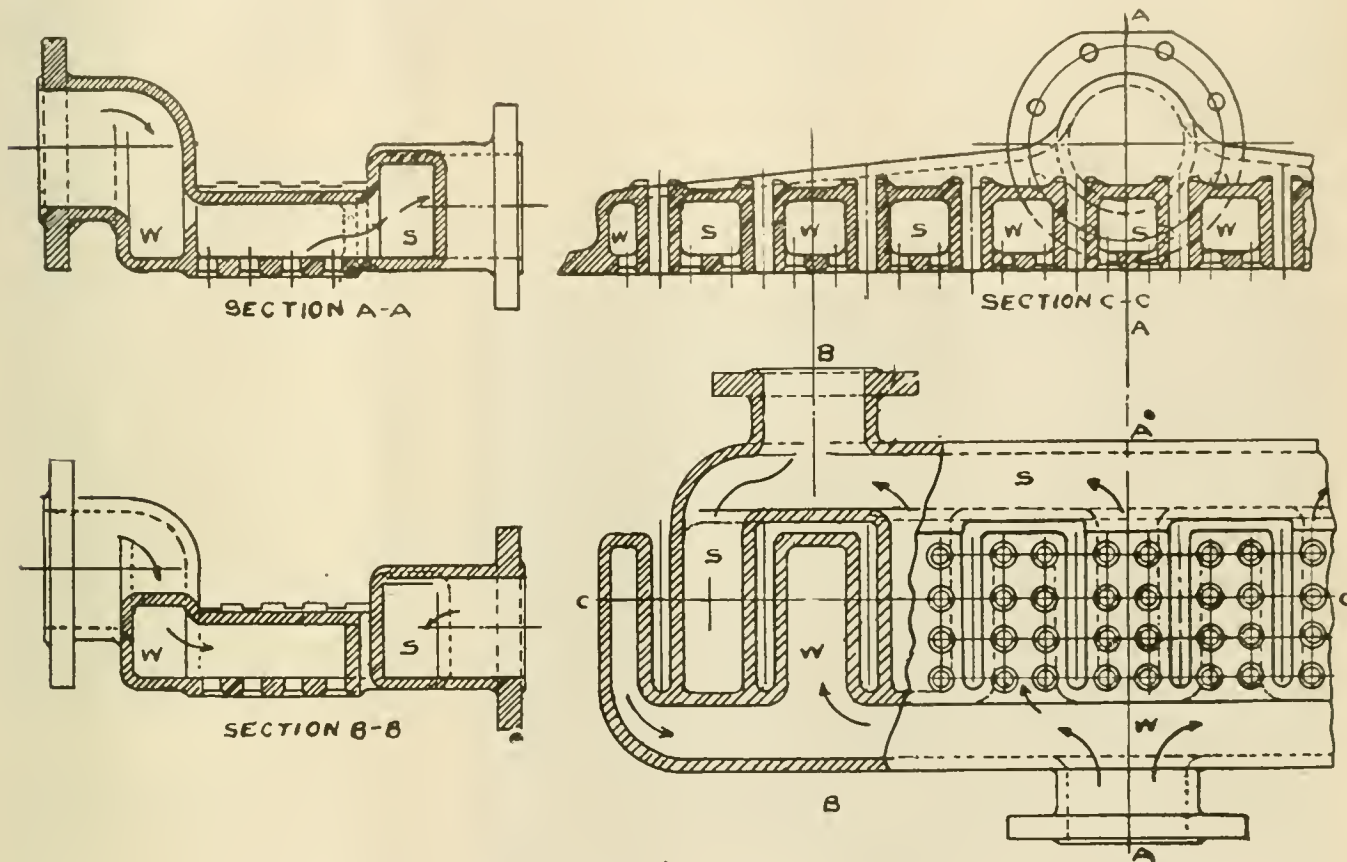

IMPROVED DESIGN OF SUPERHEATER HEADER.

possible, which will, of course, be a great advantage, but in spite of that fact there will ever be a need of the faithful and intelligent co-operation of the engine crews. This latter factor really represents the most difficult feature of the whole problem.

This report was read by Martin Whelan, chairman of the committee, who has long been known as an expert on the prevention of smoke.

DISCUSSION.

W. L. Robinson did not think it was necessary to discipline enginemen for bad smoke performance. Records should be kept of the offence and explanation called for. Close supervision is necessary. The placing of a smoke consumer on an engine is an admission that smokeless firing is impossible.

ADDRESS BY MR. McMANAMY.

Frank McManamy, chief inspector of locomotive boilers for the Interstate Commerce Commission, delivered an interesting address, his principal theme being the systematic inspection of locomotives and their attachments required under existing laws. The purpose of the law is to enforce the motto of this association, which states: "To improve the locomotive service on American railroads." A summary of his remarks was "The safe operation of railways depends upon two things—good locomotives and competent men to operate them."

SUPERHEATER.

The committee reporting upon this subject, consisting of J. E. Ingling, chairman, and P. Q. Miller, H. F. Henson, W. A. Buckbee and A. G. Kenyon, included

The superheater equipment has been standardized, and is almost identical on the 12,000 to 13,000 locomotives now operating in the United States and Canada. Its success is largely due to the broad engineering policy of those who have been interested in the introduction of superheaters to locomotive practice, as well as the campaign of education by men thoroughly familiar with superheater locomotive operation that has followed the introduction of the superheater among the various railroads that are now operating superheater locomotives successfully and deriving the full benefits from them.

The report then proceeds to give details of the construction of locomotive superheaters with the excellent results obtained from their use. A most comprehensive discussion followed, which dis-

played in a striking manner the intimate knowledge of profound engineering problems possessed by many of the members. To publish the report and the discussion thereon is away beyond our available space; but we earnestly urge that all readers interested in steam engineering secure copies of the annual report from Secretary Thompson and study the details for themselves.

#### DISCUSSION.

In the discussion of this report, W. A. Buckbee, of the Locomotive Superheater Company, took the lead. He said that in some cases where superheaters had been applied, and no other change made on the engine, the tractive power was increased about 10 per cent. This is due to the superior boiler efficiency, due to the superheater. The efficiency of the superheater increases the harder the engine is worked. It has been found that with the cylinder hot that the superheater engine will start a train that an engine using saturated steam will not move. In the saturated steam locomotive a considerable portion of the steam gets condensed when it enters the cold cylinders, thereby losing its power producing energy. The condensed water also flashes into steam at the end of the stroke-producing piston resistance, a condition not present with superheated engines.

F. P. Roesch said that in order to obtain the full benefit of superheated steam in locomotives, the engines must be so maintained that the full energy of the superheat will be obtained. He insisted that to ascertain when a superheater was doing its duty properly the use of a pyrometer is absolutely necessary. The difference between the proper temperature and an inefficient temperature is so hard to determine in the operation of a locomotive, especially when the power is used in pool service, that no engineer can be expected to tell whether or not he is obtaining the proper degree of superheat without a pyrometer. Steam should be admitted to the cylinders when the engine is drifting to provide the necessary lubrication, and there is decided benefit from the use of a brick arch. We have found that forty degrees more superheat is obtained when the arch is used, and in starting there is about 100 degrees more superheat.

In the long discussion that ensued several of the members commended the use of a pyrometer with superheated engines, and the point was made that without a pyrometer the steam gauge is the only means the fireman has as how to manipulate the fire. Under such conditions it is possible to have a full head of steam and yet have the temperature of steam so reduced that the benefit of the superheater is neutralized. The critical temperature of steam was stated to be about 570 degrees. The maintaining of this efficient

temperature is extremely difficult without the aid of a pyrometer. At way stations, when the stops do not exceed five minutes, the superheated engine has a decided advantage in starting trains, and it is now a common practice for enginemen to start the blower and open the throttle slightly to warm the cylinders before starting.

On one road 20 engines had been converted from the use of saturated steam to superheaters without any other change. Where 3,600 tons had been handled with the saturated steam engines on 200 pound boiler pressure, from 3,900 to 4,000 tons were handled by the superheater engine with a boiler pressure of 185 pounds. The consensus of opinion expressed was that a locomotive supplied with superheated steam could haul more tonnage with less fuel consumption than was possible when saturated steam produced the power.

#### HANDLING FREIGHT TRAINS.

This report was prepared by L. R. Pyle, chairman of the committee, aided by E. F. Boyle, W. G. Walton, Wm. Owens and C. W. Irving.

Most of the report was devoted to the methods and facilities for handling freight trains. Reference was made to the damage done to draft gear in switching in yards. It was said that in coupling cars in yards at 5 miles an hour a buffing shock of 255,000 pounds had been recorded. The committee recommended that uniform instructions be given to cover local conditions, and that hand brakes be kept in good condition to enable yard men to stop the cars when necessary.

One of the most fruitful causes of damage to draft gear is the difference in braking power between empty and loaded cars. The nearest approach to a remedy for this is mixing the loads and empties so that the unequal strain will be spread over the train.

Braking power on cars varies in different parts of the country from 60 to 80 per cent. of the light weight of the car, and drops from 17 to 30 per cent. when the car is loaded. What is urgently needed is a uniform braking power with both empty and loaded cars which would enable railroads to handle long, heavy freight trains faster and with less damage to draft gear.

In a new brake which has been introduced by several roads there is a standard braking power of 50 per cent. of the light weight of the car and when loaded there is 40 per cent. of the weight of the car. The greater safety, control capacity and economy possible by the use of this improved brake have been thoroughly demonstrated by various reliable tests.

#### DISCUSSION.

Walter V. Turner. Where the brake

equipment is not properly maintained, it is very difficult to give the engineer any definite instructions as to how the train should be handled. It must be remembered that the shocks are caused by the difference in velocity between the cars. This difference in velocity is caused to a large extent by the unequal braking power on the different cars. A difference of one mile per hour in the velocity of two cars, produces a shock between those cars equal to the weight of one of those vehicles, provided they are of the same weight. So it is very important that this braking power be maintained as nearly constant as possible, which means that the piston travel should be standard throughout the train. The best brake is one that produces the least velocity between the cars and which will apply them simultaneously.

T. F. Lyons. It pays to make haste slowly in braking the long, heavy trains of today. Terminal tests are very important. In making coal and water stops in cities, where there are many crossings, it is better to stop the train and draw it up to the water plug slowly, rather than to cut off from the train. By doing this the train will be ready to start after the engine has received coal and water.

F. P. Roesch said that the trouble of breaking in two is due very often to defects in the draft gear caused by rough handling in the yards. It is estimated that fully 60 per cent. of the damage to freight cars originates in the yards, and defective equipment gets out unnoticed. One break-in-two out on the road caused by this defective equipment will attract more attention and the engineer is often held to blame when it really is the fault of the men in the yards and the inspectors who permit defective equipment to get onto the road.

G. H. Wood, W. G. Wallace and L. R. Pyle blamed destructive action in yards for many of the breaks-in-two of trains that happen on the road.

#### ASSIGNMENT OF POWER.

P. O. Wood was chairman of a committee which prepared a report upon the above subject. His associates were J. D. Heyburn, D. Meadows, F. R. Melcher, and W. H. Corbett. The committee held that the assignment of power should be in the hands of an officer with absolute authority and report direct to the general manager or other high official.

The assigning of engines with regular crews versus the pooling is a very important question, which to a great extent is governed by local conditions. It is possible to run engines successfully and economically over more than one division in continued service. This will save terminal consumption of fuel and reduction of mechanical forces at intermediate points. At the end of the engine's run it should be thoroughly inspected and all necessary

work done. With modern passenger engines equipped with brick arches and superheaters, it is possible to run them over two or three divisions. A number of roads have proved that engines can be pooled successfully and economically provided there is a proper organization to inspect and repair them.

#### DISCUSSION.

W. L. Robinson: In 1904 a great many railroads followed the practice of assigning regular engines to the crews, while in 1914 most of the railroads were using the pooling system. During that time the average traction power for locomotives increased 38.6 per cent., while the ton miles per locomotive increased only 11.3 per cent. This may be due to the fact that the engines do not give the service under the pooled system that they give when they are assigned.

C. W. Irvine, E. F. Boyle, B. J. Feeney and others spoke on this subject, most of them favoring the system of assigning engines.

During the closing exercises W. O. Thompson, secretary of the association since it was formed was presented with a past president's badge, being voted an honorary past president. The honor was thoroughly deserved for the magnificent success of the association has been largely due to the work of Secretary Thompson.

#### ELECTION OF OFFICERS.

The following officers were chosen for the ensuing year: President, B. J. Feeney, Illinois Central; Memphis, Tenn.; vice-presidents, H. F. Henson, Norfolk & Western; W. L. Robinson, B. & O. Ry.; G. A. Kell, Grand Trunk; L. R. Pyle, Soo Line; treasurer, David Meadows; secretary, W. O. Thompson.

#### Railway Line Material for Direct Suspension.

The General Electric Company, Schenectady, N. Y., has issued Bulletin No. 44,004-A, superseding Bulletin 44,004, and showing many marked improvements in flexible pole brackets as well as changes in rigid pole brackets with a greater degree of simplicity in clamps and bands for holding horizontal arms to pole. Details in regard to forms of suspensions, strain insulators, double curve suspensions and wood strain insulators are also given. A large variety of ears for round and grooved wire, screw clamp ears and strain plates are also described and illustrated. Mechanical splicing sleeves, turnbuckles, trolley frogs, section switches, feeder insulators, feeder cable splicers and insulators, anchor rods and anchors, and a mass of miscellaneous data are all presented with a degree of fulness that meets every requirement in the need of material for direct suspension. Copies of this bulletin may be had on application to the company's main office at Schenectady, N. Y.

## Hydraulic Horizontal Pressure Pumps— Massive Duplex System

Two powerful hydraulic pressure pumps have just been constructed for the Puget Sound Navy Yard, Washington. They were designed by the eminent engineer, Wm. H. Wood, Media, Pa., for the United States government. The pumps are double acting, having plungers  $2\frac{7}{8}$  ins. in diameter with 12-in. strokes. They are driven by means of 100 horse power electric motors made by the General Electric Company. On the end of the motor shaft, for driving the pumps, there is a rawhide pinion working through compound gearing so as to give the pumps a capacity to deliver 75 gallons of water per minute against 1,800 pounds pressure or 60 gallons per minute against 2,000 lbs. pressure. The valve chambers are made of cast steel and are prepared with rectangular covers. The valves and the seats are of bronze, each valve seat being interchangeable.

Stephenson's locomotive "Samson" ran into a market cart containing 50 pounds of butter and 80 dozen eggs. A meeting of the directors was called, and Stephenson's suggestion of a whistle blown by steam was adopted. He went at once to a musical instrument maker in Leicester, who constructed a steam trumpet, which ten days later was tried in the presence of the board of directors. In appearance it was like a huntsman's horn, 18 ins. long and 6 ins. across at the top.

#### Japanese to Widen Railway Gauge.

Japan will probably decide to change her main railroad system from a narrow to a broad gauge. The present gauge of 3 ft. 6 ins. was adopted when the first line was built in Japan. The broader gauge can be more useful as a means of communication in connection with na-

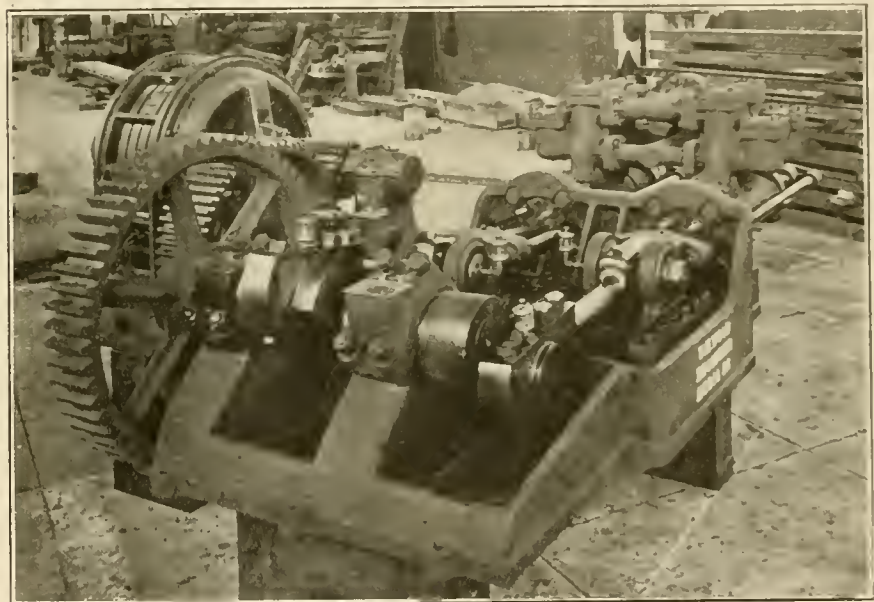

TYPE OF HYDRAULIC PUMPS FOR THE PUGET SOUND NAVY YARD.

and the crank shaft is made of forged steel. The bearings are bronze bushed and the balance of the bearings are bab-bitted. The bed plates are arranged conveniently for motor drive. There are two sets of these powerful pumps furnished which are adapted to work with one of Mr. Wood's hydraulic accumulators with a 16-in. plunger and 15-in. stroke, being fitted up with guides for keeping the course of platform and the shells of the accumulator. It is also fitted up with patented bronze automatic safety valves.

#### Origin of the Locomotive Whistle.

On May 4, 1833, there occurred an accident that gave us the locomotive whistle. It was on a level crossing between Bagworth and Thornton in England.

and the crank shaft is made of forged steel. The bearings are bronze bushed and the balance of the bearings are bab-bitted. The bed plates are arranged conveniently for motor drive. There are two sets of these powerful pumps furnished which are adapted to work with one of Mr. Wood's hydraulic accumulators with a 16-in. plunger and 15-in. stroke, being fitted up with guides for keeping the course of platform and the shells of the accumulator. It is also fitted up with patented bronze automatic safety valves.

tonal defence in time of war. Especially is the change desired in the interest of a greater development of commerce and industry. It is planned to inaugurate the tremendous task involved by widening the gauge on the main trunk line, which connects Tokio with Shimonoseki, which are 800 miles apart. This is the line which connects with Corea and the Siberian Railway.

#### American Federation of Labor.

Per capita tax reports show that in the affiliated unions there are 2,007,650 members, which makes it by far the largest federation of labor organizations in the world. In the matter of trade unionism, it seems to be generally admitted that the United States leads the world.

# Railway Engineering

A Practical Journal of Motive Power, Rolling Stock and Appliances.

Published Monthly by

**ANGUS SINCLAIR CO.**

114 Liberty St., New York.

Telephone, 746 Rector.

Cable Address, "Locong," N. Y.  
Glasgow, "Locoauto."

**Business Department:**

ANGUS SINCLAIR, D. E., Pres. and Treas.  
JAMES KENNEDY, Vice-Pres.  
HARRY A. KENNEY, Secy. and Gen. Mgr.

**Editorial Department:**

ANGUS SINCLAIR, D. E., Editor-in-Chief.  
JAMES KENNEDY, Managing Editor.  
GEORGE S. HODGINS, Editor.  
GEO. W. KIEHM, Associate Editor.  
A. J. MANSON, Associate Editor.

**London Representative:**

THE LOCOMOTIVE PUBLISHING CO., Ltd.,  
3 Amen Corner, Paternoster Row, London, E. C.

**Glasgow Representative:**

A. F. SINCLAIR, 15 Manor Road, Bellahouston,  
Glasgow.

**SUBSCRIPTION PRICE**

\$2.00 per year, \$1.00 for six months, postage paid in the United States, Canada and Mexico. For other parts of the world, \$2.50, or ten shillings. Single copies, 20 cents. Remit by Express Money Order, Draft, Post Office Order or Registered Letter.

Mailing address can be changed as often as necessary—always give old and new address, and if you subscribe in a club, state the name of the agent.

Please give prompt notice when your paper fails to reach you regularly.

Entered at the Post Office, New York, as Second-class Mail Matter.

**Traveling Engineers' Convention.**

All the organizations of railway officials have been formed for the purpose of promoting the interests of railways and most of them perform that object admirably, but some of them are much more efficient than others. In reading the reports of the various railway men's conventions, we cannot help feeling that the Traveling Engineers' Association does more to promote railway interests than any of the others. The reports of investigating committees are of a very high order, and the discussions thereon are admirable. This applies with singular force to the proceedings of the twenty-fourth convention held in Chicago in October last.

When the Traveling Engineers' Association was formed its promoters chose for a motto, "To Improve the Locomotive Engine Service of American Railroads," and all through its history of twenty-four years the members have adhered to the high principle on which the organization was established. In maintaining this principle, the education of enginemen has been closely pursued, nearly all the reports having contained matter that is decidedly instructive to the men operating locomotives. Although of a technical character, nearly all the reports are noted for their simplicity of expression, so much so, that every fireman can understand them without difficulty. The reports are primarily intended for the instruction of the traveling engineers who attend the

conventions, but they exercise even a higher function in the education of the rank and file of enginemen.

A peculiarity of the Traveling Engineers' convention is that the reports submitted by the various committees nearly all relate to current practice, to the subjects that are occupying the minds of the enginemen at the time the reports are prepared. The first subject thoroughly ventilated at last convention was mechanical stokers, which was the subject of a good report and excited an exhaustive discussion. The mechanical stoker is making rapid strides into favor with nearly all enginemen, although in the beginning of its career it met with much obstinate opposition. This was caused by some advocates of mechanical stokers asserting that the stokers would be the means of dispensing with the services of skilled firemen. Now-a-days the "iron fireman" is a highly popular personage.

The subject that occupied the greatest attention of the twenty-fourth convention was Superheaters. The report thereon was thorough and exhaustive, and the discussion that followed the reading of the report was the best discussion of an engineering subject that we have ever listened to. The report itself covers 19 pages of the usual size and discusses a variety of subjects influenced by the superheater such as fuel, water, boiler capacity, economy expected, pyrometer, brick arches, etc. The discussion that followed was very thorough and manifested wonderful familiarity with many phases of steam engineering. The fire-tube superheater has been standardized and is almost identical on from 12,000 to 13,000 locomotives, representing the most important improvement on the locomotive since steam cut-off appliances were introduced.

There was a long report on "Recommended Practice in the Make-up and Handling of Modern Freight Trains, on Both Level and Steep Grades, to Prevent Damage to Draft Gear." This report made useful recommendations concerning the handling of trains under nearly all conditions of train operation. It also devoted considerable space to the handling of brakes and on means for preventing breaks-in-two of trains. This is the kind of report that would pay railroad companies to put in pamphlet form for the guidance of trainmen and yardmen. In the discussion on brakes which is in this paper, Walter V. Turner delivered a most instructive address which we shall publish in full in a future number.

Among other subjects that occupied the attention of this convention were Smoke Elimination, Flange Oilers, Power Reverse Gear, Power Assignment and a variety of minor topics, all of them bringing out useful information for the men engaged in the handling of locomotives.

**Making the Locomotive Efficient.**

It has been truly said that it was not the astronomer who devised the telescope, nor was it the soldier who invented gunpowder. It might almost be said that it was not the railroad man who made the locomotive. The locomotive is the evolutionary cause of the railroad man, and the railroad man as such did not do everything to perfect the locomotive and bring it to the degree of efficiency it has attained to-day.

The people more than any others who are responsible for the many improvements which may be had to-day are the locomotive supply people—those firms who make and sell the accessories now so necessary to efficient locomotive operation. A well known example of this is the Westinghouse Air Brake Company. They are not locomotive builders, but they supply an accessory which has now become an indispensable requisite. There are other firms, not builders of locomotives, and they make and supply the superheater, the fire-brick arch, the pulverized fuel arrangement, the feed water heater, the steam gauge, the injector, the bell ringer, the air sander, the automatic coupler, the valve gear, the reversing mechanism, the headlight, the gauge glass, the flexible staybolt, the automatic stoker, and many other devices. Not one of these but must be bought from agents or manufacturers, outside the railroad personnel.

The men who deal in these things are experts in their various lines, and they have devoted time and thought and have spent money in developing each his own specialty. This is not to say that there are no able superintendents of motive power, surrounded by capable and intelligent men, but the fact is that the maintenance of locomotives and cars and the operation of the same is a work by itself so arduous that the assiduous performance of these duties leaves little time for studied experimentation or inventive thought.

The supply man has a straightforward incentive to do this work. He studies the locomotive problem and a leak or a particular want of efficiency strikes him, and he sets to work to better the performance of the locomotive as he believes it may be improved. He studies, devises and produces an appliance. Here the necessary co-operation of the superintendent of motive power comes to his aid, with permission to try his invention, and aid may be given in the way of practical suggestions. The work, however, comes from outside, and the mutual endeavor of railroad man and supply firm results in the evolution of a new device designed to bring about greater efficiency, and the measure of this success redounds to the pecuniary advantage of the inventor.

This important work; this tireless hunt for better operating appliances and greater efficiency exerts a powerful influence on



the locomotive, considered solely as a mechanical power producer. It becomes a better machine. Its greater efficiency spells economy on the railway company's ledger. The appliance maker has created a new mechanical industry in which thousands of men are employed, which were not hitherto mobilized for any industrial campaign, and it lightens the labors of those engaged in locomotive operation and enables them to turn out more work and better work than has heretofore been possible.

With all due credit, generously and fairly given to the intelligence and judgment of railroad men who pick out with discrimination the better from the poorer among the appliances offered from the outside, there nevertheless stands the important fact that the supply man has been the chief factor in the sum total of improvement, which undoubtedly exists to-day. The supply man has directed his energy to the practical work of definite improvement. Each firm devotes itself, almost automatically, to a certain line, so that the efficiency which resides in the division of labor is theirs. They are working for profit, and manufacturing costs are scrutinized. They are making the American locomotive a better machine, incidentally able to compete on equal or superior terms with similar work done in other lands. They have created a vast industry at home, and have held scientific and trustworthy advance to be the legitimate end sought. Progress there has been, in which, though there may be the brief ebb and flow of the advancing tide, yet the full flood is in the one direction. An advance is being made in which there is no ultimate step backward.

#### Test of Coal.

The fuel question is very active among our railroads at present, and ardent hopes are entertained that the methods of utilizing coal dust for locomotive fuel is destined to greatly reduce the cost of locomotive fuel in the near future. We believe this to be true and think that no line of improvement is destined to reduce the expense of railroad operating so effectively as the combustion of coal refuse.

While this is no doubt true, we believe that more attention directed to the quality of coal bought by most of the railroads would lead to better results in steam generation. There is great diversity in the quality of coal bought for use in the locomotives all over the country. It is no uncommon thing for the coal from one set of mines to have from 10 to 20 per cent. more carbon than the coal from another source of supply. As the carbon is the vital element in the coal, care ought to be taken to choose the best quality of the coal, as the price is generally about the same.

There is too much tendency among railroad officials to regard coal merely as fuel without troubling themselves to find out if any difference in quality exists. Yet there are very simple forms for testing coal that ought to be familiar to purchasers and users. One simple test is based upon the quantity of pure lead that will be released from its oxide by a given weight of carbon. Litharge is oxide of lead, and contains 34.5 units of lead to one of oxygen. When finely powdered coal, mixed with oxide of lead, is heated to the combining temperature, the oxygen of the compound unites with the carbon and leaves the metallic lead. The quantity of lead precipitated gives the means of determining how much carbon there was in the coal. Any intelligent man ought to be able to work out that experiment.

#### Ventilation of Railroad Cars.

In the matter of ventilation of railroad cars one important point stands out very clearly and that is, that much that we have learned about ventilating buildings is inapplicable to the ventilation of moving railroad cars, yet the proper ventilation of these vehicles is just as important as schools, large offices or public assembly halls.

In the matter of schools, as many cubic feet of fresh air are allowed to ten pupils as is contained in the entire body of a 40-foot car, and this air must be constantly removed and an equal amount of fresh air brought in. This could be very well done by opening the doors at each end of the car and letting the air flow through, but there are practical difficulties in the way of applying this crude method of ventilation.

In the first place draughts must not be produced. The changing of the air must not sensibly reduce the temperature of the car. The ventilator openings must keep out rain and snow, and the whole must operate automatically, or as nearly so as possible, and this means that the ventilating system shall not take up the time of a trainman to an undue extent. It is clear that the whole problem is beset with difficulties of a very real kind, and that a haphazard system blindly applied, is bound to fail.

To add to the complications in the work of ventilation, railroad cars run at varying speeds, they change their direction and from time to time, they halt. Any body of persons' collected from "hither and yon," are never unanimous in their opinion as to whether a car is too hot or too cold, yet at the very first breath of Spring the windows are opened and all seek for the draught, to which they objected so strenuously in the winter.

A car may be very satisfactorily ventilated, and yet not have the "clean"

smell which so many people think is the test of efficient ventilation. An "undesirable citizen" may vitiate the surrounding air, to the great discomfort of his fellow passengers, and yet the flow of pure air into the car may be free and wholesome. Like the foot-print of a horse in a clear stream flowing over a muddy bed, the stirred up ooze and slime may foul the whole flow below it. A similar condition with air cannot legitimately be charged against the ventilating system.

Car ventilators are not air purifiers and the odor from the occupants of the car or the dust and grit admitted through the openings, do not alter the efficiency of the ventilators, whose object is to permit the inflow and exit of air, at a certain rate, in a given time. Neither does the ventilator cool the air as it comes in, and any cooling effect that may be experienced, results from the evaporation of whatever moisture there may be present in the car or on the bodies of the passengers.

The monitor roof, or clearstory, was originally designed for ventilation purposes, but the series of openings usually provided along the raised roof are not by any means suited to provide for the proper or regular and even change of air, nor are they entirely satisfactory at all times, when wind, rain or snow beat steadily at them or when a "cold wave" envelops the moving train.

We have here not proposed any definite system of ventilation, we have rather tried to set forth briefly some of the difficulties which beset those who have this work in hand; and we commend these points to the thoughtful attention of those to whom the providing and maintaining a satisfactory and efficient system is one of the duties of their office, and we bespeak intelligent judgment from the traveling public.

#### Announcement.

We desire to state briefly that the pressure upon our columns has been such that we have been compelled to shorten some of the departments of RAILWAY AND LOCOMOTIVE ENGINEERING, and it will be observed that the space devoted to what are usually known as editorials has been diminished. Our Question and Answer department has been eliminated, and all questions in the future will be promptly answered by mail. Many of them were almost repetitions, and the space can be readily filled with new matter. Next month we will begin a series of articles embracing the illustration and description of a complete set of tools used in air brake repairs, and other new features will be incorporated at the same time so as to bring our reading pages up (even more than they are now, wherever possible) to the high standard of excellence which we have set before us.

# Electric Arc Welding

## II. Details and Illustrations of Operations

In the fully equipped railroad repair shops the electric, oxy-acetylene and thermit welding appliances are to be found in operation. Each has its special advantage, the electric arc process being specially suitable for what may be classed as plate work, the oxy-acetylene for cutting and general work, and the thermit process for heavy kinds of work such as frame welding, wheel repairs and other work of a heavy kind. The success of the various kinds of welding depends largely on the skill of the welder, and as we have already stated the operations necessary are not to be learned in a day.

Confining ourselves in the meantime to the subject of electric arc welding and taking up briefly the question of equipment, it may be stated that if direct current is available from a shop or commercial circuit, welding can be done from this source of electric supply, but it is not economical; in fact, it is a waste of power and should not be thought of except, perhaps, where welding may be done at only rare intervals. In such a case unless particular arrangements are made in regard to insulating the work, there is a certain amount of danger not only to the welding operators but to other employees. Where there is a reasonable amount of welding to be done it is always preferable to use a motor generator set, the motor being constructed with attachments suitable for operation in the shop, and used to drive a low voltage generator. The generator may, if necessary, be driven by belts from a steam or gas engine, or from a suitable line shaft in cases where electric power is not available.

Various sizes of welds require different strengths of current, and means of regulating the current is necessary. This is readily effected by inserting resistance in the welding circuit, connecting it in series in the arc. This resistance is necessary, otherwise a short circuit would occur where the electrode was applied to the work when striking the arc. This would occur even after the arc is drawn and operation begun. The series resistance has the effect of steadying the arc. An electrode holder must be supplied, and if there are a number of forms, nearly all of which are so constructed that a spring or clamp which securely holds the electrode, may also readily remove it. The holder adapted for a metal electrode differs from that for the carbon electrode, being lighter and more compact. The carbon electrode holder also has a shield on the handle to protect the hand of the operator from the heat of the arc. This is not necessary in the case of the metal electrode, as the gloves of the operator are sufficient protection. A hood or shield is

also necessary for protecting the eyes from the dazzling brilliancy of the electric light. Experience has shown that the window of the hood or shield is best adapted for operation when several layers of glass, one or more of red and others of blue or green, the combination being of a more subdued and softer effect on the eyes than any one of these colors used alone. A



Fig. 1.

protection around the work is sometimes necessary as the strong light is confusing to other workmen who may be engaged in the vicinity.

Coming to the actual operation of welding, and assuming that two steel plates are ready for welding bevelled as shown in Fig. 1. If the plates are more than  $\frac{1}{2}$  in. in thickness it is good practice to bevel



Fig. 2

from both sides, if it is practicable to apply the electrode on both sides. The work, if small, may be laid in a metal table forming the positive terminal. With the resistance of the circuit properly adjusted for the work in hand, the circuit breaker and main switch being closed, the operator takes the electrode holder in one of his gloved hands, and with filling ma-

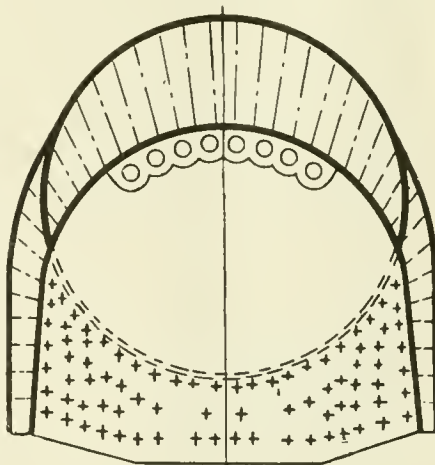

FIG. 3.

terial, if necessary, within easy distance, and closing the window of his hood, and touching the electrode to the metal to be welded and instantly withdrawing it to a distance of at least two inches, thus igniting the arc. It should be borne in mind that with a long arc there is a lesser degree of opportunity for particles of carbon to enter the molten metal and thereby pro-

duce a hard weld. The heating effect of a long arc is also more regular with a more even distribution. An arc three or four inches in length is the most serviceable. If the arc is too strong, or too weak from insufficient current, the resistance in the circuit may be increased or decreased until the desirable arc is obtained.

A rotary motion of the hand is necessary in order that the flame may strike upon a comparatively large area of the surface about the weld desired, will take place, and the resultant cooling will follow with a lessened danger of cracking or the making of a hard weld, the arc being continued to play upon the surface of the metal until the metal is in a state of fusion, and the filling material, if used, combines and the whole is thoroughly melted. It is advisable, if at all possible, to persist in one continuous application of the arc until the opening is entirely filled, as shown in Fig. 2. If a second application should be necessary care should be taken to remove all scale. A wire brush will readily clean the surface sufficiently, although sometimes chipping may be resorted to with advantage.

It may be stated here that with proper welding material, correct temperature and accurate heat control a perfect metal is formed, but the perfection in welding frequently eludes even the most painstaking operator. It is essential that the arc must actually touch and play over every part of the surface of the joint, otherwise the complete fusing of every part is impossible. There is no particular difficulty in the operation. It is a mere matter of taking care rather than of profound skill. The trouble, if it does come, is that the defects are completely hidden. No kind of inspection reveals the flaws until the actual tests are made. It need hardly be said that it is necessary to begin the welding process at the bottom of the weld. Fusing will naturally begin there first as the metal is thinner and the weld can be built up in a solid mass if the proper care is taken in the manipulation of the arc.

It should be borne in mind that although carbon electrodes have been referred to, the metal electrode process is a later development and has a distinct field of application differing in many cases from the older process. It has an important advantage in work where it is necessary to localize the heat to the greatest extent possible, thereby lessening the strains on account of expansion and contraction. There is perhaps no better illustration of this than in the case of welding a cracked bridge in a flue sheet. With the metal electrode process also it is possible that welding can be done in a vertical plane, and in many cases from be-

neath the piece where the repair is necessary. It may be stated here that the metal electrode differs from the carbon electrode in the length of the arc, the metal electrode being comparatively short, and also has the quality of furnishing the filling material itself as it fuses and flows into the work to be welded. Not only so, but as we stated in our article on the subject last month, a specially alloyed steel containing an extra quantity of manganese and copper has been found to add to the stability of the weld on account of the amount of these alloys that is burned out in the formation of the weld.

Again, as we have already stated, perhaps the most useful field for arc welding with the improved metallic electrode is in its varied use in railroad repair shops. The ingenuity displayed by skilled welders seems limitless. As an illustration, it is well known that small cracks are very apt to occur over the upper flues in the firebox side of the flue sheet. Before the introduction of autogenous welding this defect was difficult of repair. Small holes were drilled in the cracks, the holes were tapped and threaded pieces were screwed in and carefully riveted over, but in a short time the leaks showed again with all their attendant annoyance. Fig. 3 shows a method in vogue in the Long Island Railroad shops of effectually overcoming the difficulty. A piece of steel plate 3-16 in. thick is shaped sufficiently long to cover the refractory flues, with their attendant cracks, extending a short distance under the flue holes and lapping over the curve of the sheet on the top. This plate is securely welded on the water side of the flue sheet, and the flue holes subsequently filled up by the welding process on the firebox side. If it is deemed necessary to drill new holes for the flues this may be done and by leaving a slightly longer bridge between the new holes and the adjacent holes, a degree of security being thereby reached that has not failed in a single instance.

This may properly be looked upon as one of the smaller operations in repairing firebox or flue sheets. It is quite common to cut out pieces in the sides of firebox sheets extending to 10 ft. in length and embracing an area occupied by seven rows of flexible staybolts, and fitting a new piece with a V shaped joint as shown in Fig. 4 the piece may be welded in place by a skilled workman in five hours, and the bolts returned to their places, that portion of the sheet extending over the mud ring rarely requiring to be disturbed. Pieces of pitted crown sheets may be speedily removed in the same way and a new piece welded on the water side. Furnace doors also have been cut out on account of crack development, and a completed piece embracing outside and inside sheets fitted in and welded by the same process with a saving of 36 tap bolts. By the old process of repairing, the operation

would occupy two men at least three days time, whereas one skilled welder would complete the job in nine hours, and after long continued service no further cracking of seams in the region of the fire doors has been developed. The extent of the repair is shown in Fig. 5. Indeed, it is safe to state that the repairing of firebox sheets is one of the most common jobs performed by the electric arc process in railroad work, in many instances the

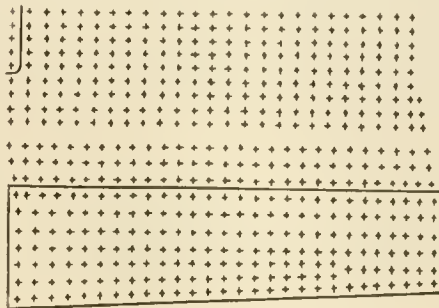

FIG. 4.

welded sheets being partially renewed a second or third time.

The building up of worn parts of frames that may be cut by spring hangers and other appliances is also coming rapidly into use, as well as the stirrups of driving boxes and other parts subject to excessive pressure and consequent deterioration, may in a short time be made as good as new. Generally speaking, in the complete overhauling of a locomotive, which occurs at intervals of about a year and a half of

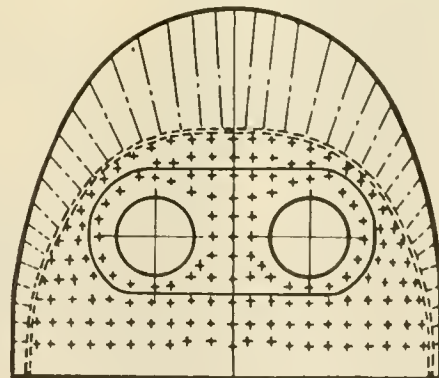

FIG. 5.

regular service involving a running of 50,000 or 60,000 miles, a great economy is effected by the use of the electric arc welding process. A new back flue sheet is becoming more and more necessary in recent service, and this important piece of work is greatly facilitated by the use of the electric arc, and in the application of patches, when necessary, almost a double period of service can be got out of the modern locomotive boiler, when it has been so equipped. The advantages secured by this form of welding are only now in the earlier stages and as the field to be covered is wide, one may expect to see numerous improvements as time goes on.

**Powdered Paper Refuse Used Instead of Coal.**

A substitute for coal, manufactured from the waste material of paper factories, is described in a report from the American Consul General at Christiania, Norway.

The inventor of the process is Mr. R. V. Strelenert, a Gothenburg engineer. The invention consists of producing "coal" powder from sulphite lye obtained from the sulphite factories. A plant is to be built and equipped at Greaker for this purpose. It is stated that the result of the process produces a "coal" powder almost equal in calorific value to first class coal—that is about 6,900 calories against 7,000 in the case of the best English coal. The process having been tested and proved to the satisfaction of Norwegian interests, a company under the title of Sulphite Coal, Limited, has been formed with a minimum capital of about \$428,000.

It has been estimated that if coal powder is made of all the sulphite lye refuse in Norway, 30 per cent. of the import of coal would be replaced. The works will be erected in the vicinity of the sulphite mill at Greaker, Norway, so that the lye may be transferred to the "coal factory," as it is here spoken of, direct from the sulphite kilns.

According to the Strelenert method, the lye will be mixed with some foreign material after the boiling of the sulphite and then it will be transferred to a large kiln where it is boiled under high pressure. During this process the lye is changed and the substance which is converted into "coal," sinks to the bottom and is then taken out in the form of a thick black paste. The water which remains in the paste is then removed by placing it in a centrifugal machine, and the residue is the "coal" in a powdered form. The powder will then in all probability be made into briquettes and used in the same way that coal is used.

It may seem strange that "coal" can be produced from lye, but under the sulphite process only 45 per cent. of the weight of the timber is utilized in making paper and the remainder falls into the lye as refuse, and it is this matter which is over one-half of the timber, which Mr. Strelenert's process transforms into fuel. The wood thrown into the lye when making wood pulp, from which paper is ultimately derived, is at the present time completely lost, and the loss is considerable. This waste material, when made available, forms a most valuable by-product. The sale of the by-product, in this case as in others, has an economic value by reason of the fact that it tends to cheapen the cost of production, so that what wood pulp there is made, becomes cheaper, and the cost of paper has a tendency to become lower in price. Those who can advantageously use powdered fuel find this form now available at a reasonable price.

# Air Brake Department

## The Universal Control Equipment—Improvements in Brakes for Passenger Cars

Some months ago we stated that a complete description of the construction and operation of the U. C. (Universal Control) passenger car brake equipment would be printed in these columns as soon as the necessary cuts of the apparatus could be secured, but up to the

feel inclined, for various reasons, to give this brake system any publicity until after it had been thoroughly tested out under actual conditions of service. It has now been in operation for several years and appears to be practically perfect in every detail and the company has no further objection to descriptions of the apparatus.

it is not desired to touch upon the electric operation until after the present pneumatic operation is thoroughly explained and the reason this cut was used is that it is of a suitable size for these pages. The photographic views show the universal valve from two different angles and the blanking flange is shown on the

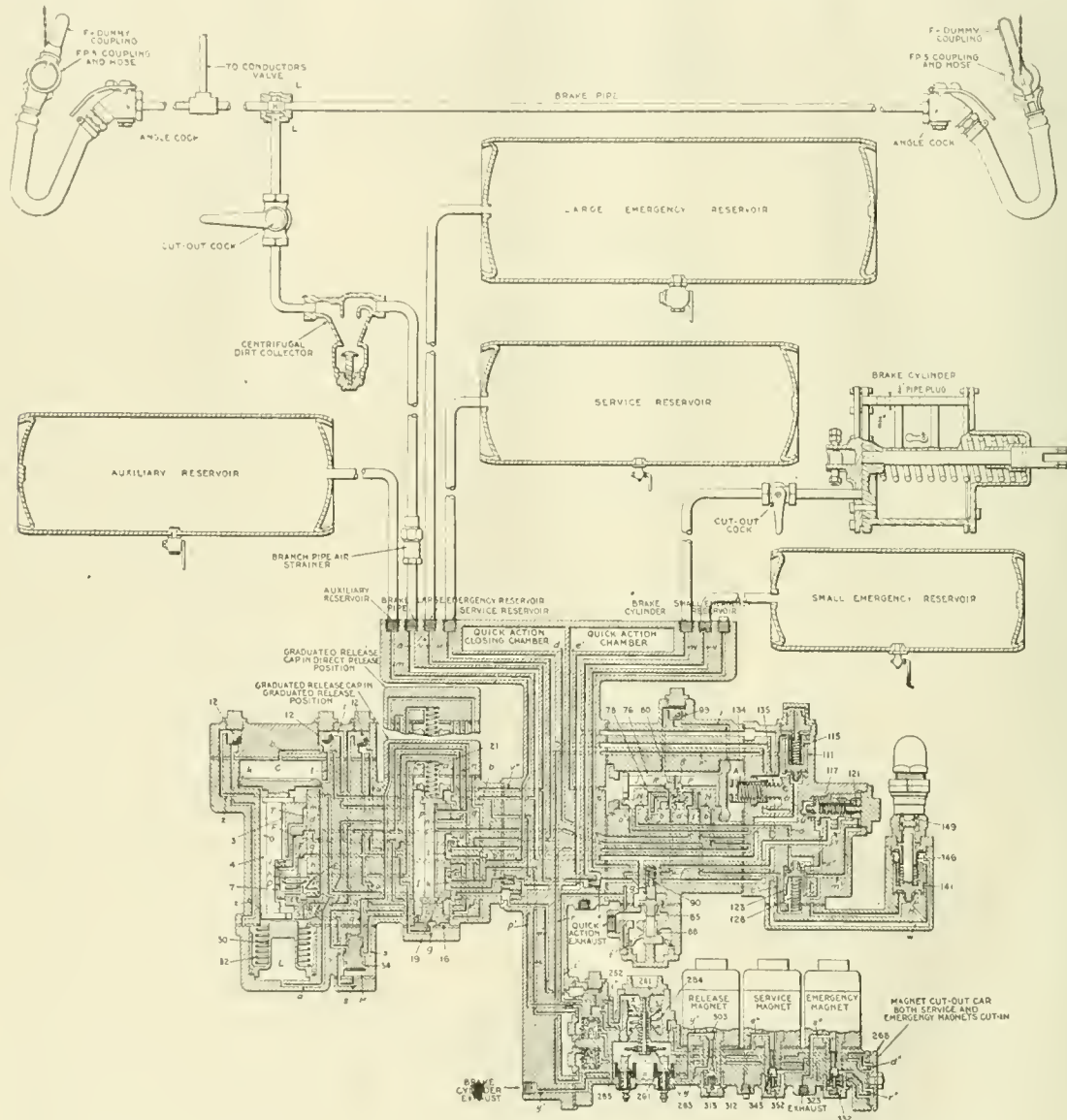

GENERAL ARRANGEMENT OF THE UE UNIVERSAL EQUIPMENT FOR PASSENGER CARS.

present time they were not available, first, for the reason that the equipment was largely in an experimental stage and a number of changes were made in the universal valve for the purpose of eliminating undesired features which developed after the valve had been in service for a considerable period of time; and further, the Air Brake Company did not

The writer considers himself fortunate in having been able to keep in close contact with the operation of this brake from the time it was first placed in service, and at the present time considers it to be the only perfect passenger car brake in steam road service. The illustration of the general arrangement shows the electric attachments, but

face for the electric portion as the valve appears in service at the present time, operating in harmony with all previous types of brake equipments. When this brake was designed for the Pennsylvania Railroad, the emergency stopping distance of the train was not the only consideration, as the railroad company demanded a brake that would

also manifest certain improvements over triple valve operation, and in order for anyone to obtain a thorough knowledge of the operation of the brake it will be necessary to first understand the objects sought in the design of the universal valve, and thereafter the reasons for using the various portions and the manner in which the parts operate and why they assume the various positions will be readily comprehended.

The idea was first to design a valve for the operation of a brake cylinder, or two cylinders per car, that would operate in harmony with all previous types of triple valves and control valves and be so arranged that when desired it could also be electrically operated without any change in the pneumatic portions. It was also desired to retain all of the automatic features of the triple valve and eliminate the undesirable ones, such as undesired quick action of brakes, stuck brakes or brakes failing to release when desired and the application of brakes when not desired, the latter usually being termed as "brakes creeping on."

In order to accomplish the elimination of undesired quick action, it was necessary to entirely separate the service and emergency functions, the service portion being on one side of the bracket and the emergency portion on the other, and the operation of the service portion is entirely independent of the operation of the quick action or emergency portion.

In order to prevent the undesired operation of brakes, that is, the creeping on of brakes when the train is running along the road with the brake valve handle in running position, it was necessary to design a valve that requires a definite brake pipe reduction of 5 or 6 lbs. to produce an application of the brake. This becomes apparent when it is understood that the reason that brakes apply under this condition is that the application is due to brake pipe leakage and a defective condition of the brake pipe feed valve, or, in other words, that a triple valve in the train is more sensitive to respond to the brake pipe reduction through leakage than the feed valve is sensitive to open and supply the leakage. Anyone who has not experienced these troubles in brake operation is indeed fortunate, but where it is a practice to mount worn air hose clutches or couplings on new hose and to locate feed valves on top of the locomotive boiler or where they are subject to very high temperatures, these troubles will be experienced when the train rounds a sharp curve or passes over a short cross-over.

In order to positively insure the release of brakes when desired under the various different conditions encountered, it was necessary to so design the universal valve that an increase of from 1 to 1½ lbs. in pressure in the brake pipe would cause a movement that would

bleed the brake off in the same manner that a triple valve releases when the bleeder cock in the auxiliary reservoir is opened, and at the same time it was necessary to accomplish the release without using air pressure from the brake pipe for a recharge of the system until after all of the brakes have had ample time to release.

In order to maintain uniformity of operation with other types of brakes it was necessary to obtain full service braking ratio, or 60 lbs. brake-cylinder pressure with a 24-lb. drop in the stored volume for the operation of the brake cylinder in service, or in other words, the 60 lbs. brake-cylinder pressure is to be obtained with a 24-lb. brake pipe reduction, and as this pressure is not to be exceeded during ordinary service operation a safety valve was necessary.

Obviously, it would be economical and convenient if but one size of operating valve could be provided for all different

the quick action throughout the train by opening the brake pipe to the atmosphere at each universal valve in the train.

The emergency brake cylinder pressure or emergency braking ratio may be any figure desired, regulated by the sizes of the reservoirs employed, and if a braking ratio higher than 150 per cent. is desired, two brake cylinders per car may be used.

Safety and protective features are added whereby a depletion of the brake pipe pressure results in an emergency application of the brake, that is, when the pressure in the brake pipe is reduced to a predetermined figure from any cause whatever the brake will work in quick action with full emergency braking ratio. By the employment of large reservoir volumes there is also ample protection against a loss of train control through a depletion of air pressure.

Positive release after an emergency application is also provided through an arrangement whereby the brake pipe

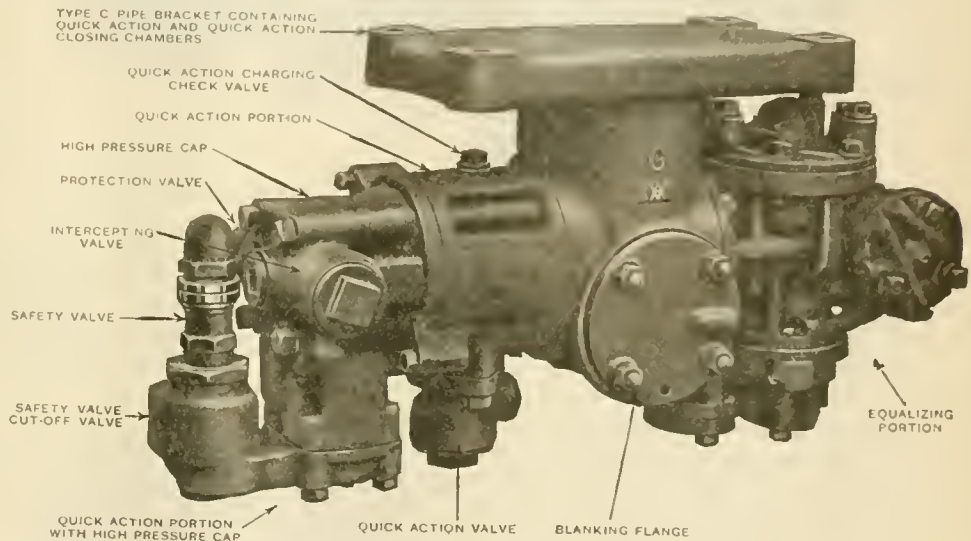

VIEW OF UNIVERSAL VALVE FROM EMERGENCY PORTION SIDE.

sizes of brake cylinders, and this, also, has been accomplished by controlling the flow of air to and from the brake cylinders in service operations through different sized choke plugs in the main bracket, which is a fixture on the car.

A graduated release of the pressure from the brake cylinders is provided during pneumatic operation, which may be used or be cut out entirely. Quick service features are obtained when the valve is electrically operated. With this improvement in the service operation, the emergency or quick action operation was also improved upon in that the high emergency brake cylinder pressure is obtainable at any time after or during a full service application of the brakes and the high pressure is retained to the point of stop.

Coincident with the high emergency brake-cylinder pressure, provision is made for positively continuing or propagating

pressure need only be increased above the point of equalization of brake cylinder and service volumes, regardless of the pressure developed thereafter, which may be as high as 105 lbs. from a 110-lb. brake pipe pressure.

These features are now considered to be essential in a satisfactory brake for modern passenger train service, and when this is taken into consideration it will be realized that the features are obtained with very few additional parts as compared with the results attained.

In order to obtain the desired actions it was necessary to divide the stored volume for service operation, one of these reservoirs being the auxiliary reservoir, the other the service reservoir, and an emergency reservoir is also necessary, which may, or may not, be divided into two separate volumes, depending upon the emergency braking ratio desired.

In the Pennsylvania Railroad equip-

ment, which will be described, the emergency reservoir volume is divided, the large volume being used for a quick recharge of the service reservoir after a service brake application, the graduated release feature being cut out, and the small emergency reservoir being used to provide a higher brake-cylinder pressure for emergencies.

reservoir, 20½x48, and the small emergency reservoir depending upon the emergency braking ratio desired. To maintain uniformity with triple valve equipments the P. R. R. size is 10x33 ins. For the 18-in. cylinder the 10x33 auxiliary, the 16x33 service and the 20½x54 large emergency reservoir are used, and for the 14-in. brake cylinder the same

will not always give the desired results in modern passenger service for the reason that the pressure may be withdrawn from the brake pipe at a more rapid rate than at which it can be restored; therefore, the ordinary types of triple valves may apply the brakes or be moved to their application position at a time when it is not desired, and conversely they may remain applied at a time when it is desired to move them to release position. This defective release action is also aggravated by the fact that all of the compressed air required for recharging the auxiliary reservoirs after a brake application must be obtained from the brake pipe, and this drain on the brake pipe commences before the triple valves at the rear end of a long train have been moved to their release position, consequently this drain on the pressure in the brake pipe may not only retard, but actually prevent the release of brakes on the rear end of a train.

Air brake engineers have agreed that the service braking ratio for a passenger car should be 90 per cent., based on a 24-lb. drop in pressure in the auxiliary reservoir, to be obtained in not less than seven seconds' time, and that the emergency braking ratio should not be less than 150 per cent. and should be retained to the point of stop, if the shortest possible stop is desired in cases of emergency. The high speed brake will not develop more than 125 or 130 per cent. emergency braking ratio at the maximum brake-cylinder pressure, and this will be reduced to about 90 per cent. by the time the train comes to a stop unless the application is made at a low rate of speed.

In contemplating a new type of passenger car brake, the average railroad man sees only a new idea or a manifestation of inventive faculty, while the fact of the matter is that each one of the

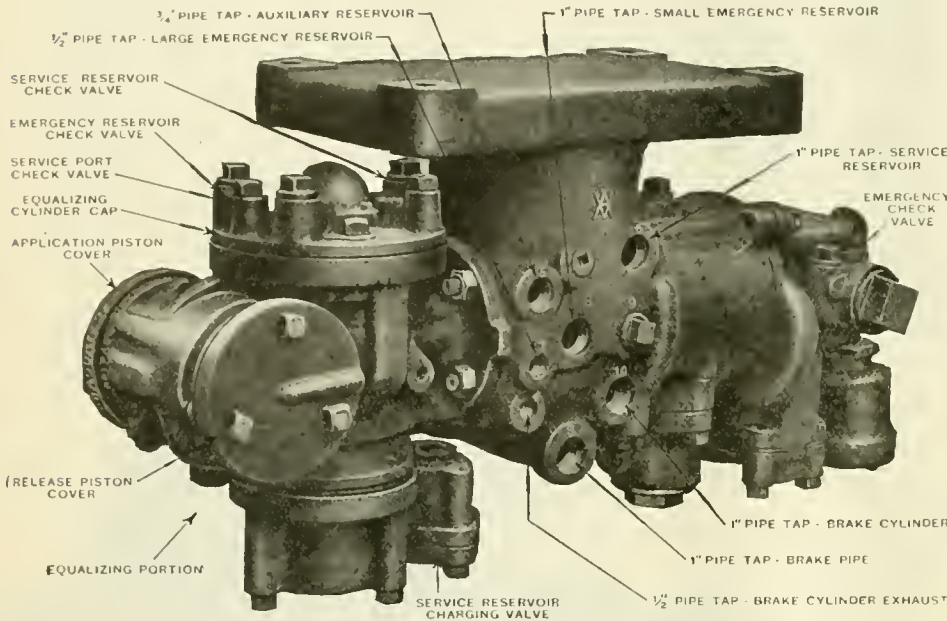

VIEW OF UNIVERSAL VALVE FROM EQUALIZING PORTION SIDE.

All pipe connections from the brake pipe and reservoirs are made to the main bracket, which is a fixture on the car, so that any of the movable or operation portions of the valve may be removed without disconnecting any pipes.

The large emergency reservoir is sometimes termed the quick recharge reservoir and the smaller reservoir is called the small emergency reservoir, and each reservoir has a separate connection with the universal valve bracket as well as the brake pipe and brake cylinder. The brake pipe branch contains the usual cut out cock and centrifugal dirt collector. The automatic brake slack adjuster is used on the brake cylinder and the brake cylinder pipe contains a cut out cock whereby the brake may be cut out for repairs or on account of defective brake rigging without bleeding the compressed air out of the reservoir or for maintaining pressure for the water raising or other systems that may be operated with compressed air.

The auxiliary reservoir remains a standard size, 10x33 ins. for all sizes of brake cylinders, but the service reservoir volume varies with the size of the brake cylinder so that the combined volumes equal that of the standard size of auxiliary reservoir used with the brake cylinders on triple valve equipments.

With the 16-in. brake cylinder, the auxiliary reservoir will be 10x33, the service reservoir, 14x33; the large emergency

auxiliary, the 12x33 service reservoir and the 20½x36-in. large emergency reservoir.

In next month's issue the operation of the universal valve will be touched upon.

#### Improvements in Brakes for Passenger Cars.

The readers of these columns are well aware that there has been a remarkable

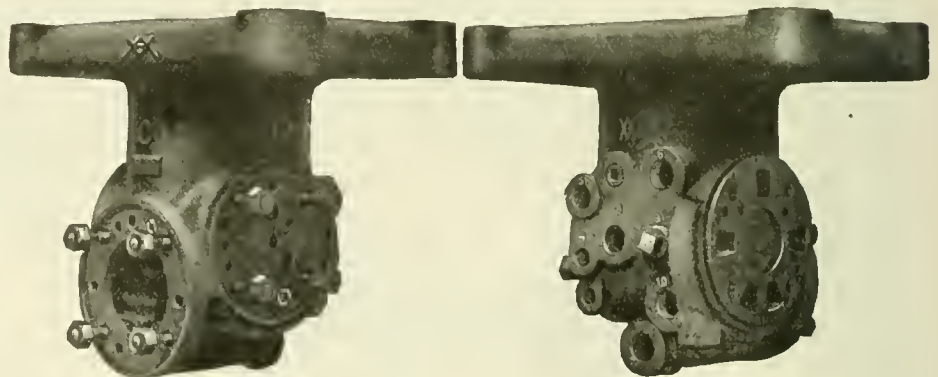

UE-12 UNIVERSAL VALVE PIPE BRACKET.

improvement made in the operation of passenger car brakes; in fact, the ordinary high speed brake or the type P triple valve equipments are generally considered as being an obsolete type of passenger car brake. It is generally recognized that a car brake operating valve that applies on the same differential in pressure that is required to release it

equipments was designed to meet a certain requirement and each one has in turn fulfilled the expectations. When the weights of cars and locomotives had increased to such an extent that the high speed brake was no longer able to stop a train of cars from a 60-mile per hour speed on a level track in less than from 1,800 to 2,200 ft. distance, a more effi-

cient air brake was demanded and the brake manufacturers responded with brake equipments that would meet the various conditions.

The L. N. equipment was designed on what may be termed the spur of the moment. During a competitive brake trial the high speed brake failed to stop the train in the required distance, by about 300 or 400 ft., and Mr. Turner told his engineers at the Air Brake Company's shops over the telephone just what kind of a valve he desired for the purpose of stopping the train in question in the required distance, and this valve was made and applied to the cars within four days of the time Mr. Turner requested it. With the addition of another air reservoir on the car it did the work and was afterward developed into what is now the L. N. equipment. Obviously, the chief requirement at this particular time was the emergency stopping distance, but other features such as quick service and graduated release were added.

A study of the summary of the air brake tests at Toledo, O., in 1909, will show that the L. N. brake failed to meet the requirements, and that something more than the high brake cylinder pressure developed by this equipment was necessary if the weight of cars then used were to be stopped in a distance of 1,200 ft. from a 60-mile per hour speed, which was decided upon by the Master Car Builders' Committee to be a distance in which a train of cars should be stopped by an efficient air brake. At this time it was also discovered that something more than a high brake-cylinder pressure was required to produce the desired stop distance, and during the tests Mr. Turner designed a brake with two brake cylinders per car, one for service and both for emergency stops, or 180 per cent. emergency braking ratio was obtained through the use of the two cylinders, and this was afterwards known as the P. C. or passenger control equipment. This brake, with the consequent building up of the foundation brake gear, provides an adequate brake for modern heavy passenger cars.

The most serious air brake problem of today is not, however, in the air actuated mechanism, but in the foundation brake gear, for obviously, the high brake cylinder pressures are of very little advantage if a large per cent. of the gain in pressure is lost through inefficient brake rigging.

The foundation brake gear problem has been solved by the clasp type of foundation brake gear, or the two brake shoe per wheel system, and the advantages of this particular type of brake rigging is so evident that it is almost a crime to equip a car with the old standard rigging. Its advantages can be summed up in almost one word when it is understood that with a well designed clasp brake the difference

between standing and running travel of the brake cylinder piston is about  $\frac{5}{8}$  of an in. During the Toledo tests the difference with the standard rigging as a result of an emergency application was as much as 5 and 6 ins., due to distorting the rigging and trucks and pulling the trucks closer together.

The Pennsylvania Railroad, however, demanded an improved brake that would not only shorten the emergency stopping distance, but would manifest an improvement in service operation, and the U. C. or universal control equipment was built for this railroad. Their demands at this time were so exacting that the use of electric current was necessary to obtain the desired results, but its operation was so successful that this brake has been adopted by them as their standard, there being hundreds of the valves in use, pneumatically operated, and by the end of the year 1919 the brakes on all of their fast passenger trains, if not on all passenger equipment, will be electrically operated.

#### An Automatic Stop.

A simple automatic stop applied to a locomotive has recently been brought out by Mr. M. B. Bulla, a conductor on the El Paso & Southwestern. It consists of a control mechanism, placed in a box on the locomotive. In connection with this is a storage battery of about 6 volts, and a contact shoe situated on the tender. There is also a steel brush attached to the end of a tie adjacent to a signal. The brush is used instead of the ramp which is a part of other systems, and the brush

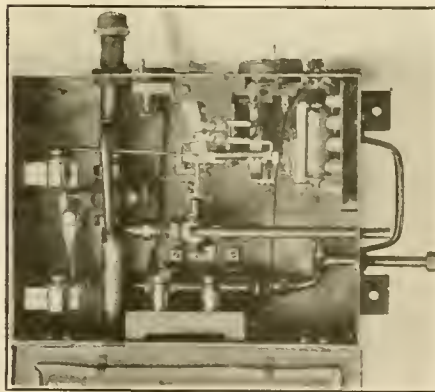

BULLA STOP SIGNAL MECHANISM.

is placed the desired distance ahead of each automatic signal.

Bond wires are used to bridge the insulated joint so that any dragging material which tore out the brush would break the track circuit and put the signal at "stop." The brush is connected to the rail through a relay which is actuated by the signal battery and controlled by a circuit controller on the signal mechanism.

When the signal is at "stop," connection between brush and rail is completed.

The circuit may be broken through the track relay. This is so arranged to prevent the signal sticking at clear. This apparatus has been given a trial on the El Paso & Southwestern, and also on the Galveston, Harrison & San Antonio, and has worked satisfactorily. The type of apparatus used, is that referred to in this article.

The form of the mechanism need not be minutely described here. It works all right, and the brush is designed to be available when the ground is covered with snow and ice. The fundamental idea in this as in other "stop" signals, is to prevent a man from making a failure. Many people, while believing in the integrity of purpose of a locomotive engineer, yet are convinced that there are brief times, when, strictly speaking, he is not his own master. It has been noticed that a man who for some reason makes a failure is liable to do it again in a short time, and to do it again until as some say "his luck changes." This is not the explanation, but the phenomenon exists, and Mr. Bulla's stop signal is a legitimate attempt to deal with the many vagaries of the normal human mind, and it is an endeavor to prevent the momentary lapses which are all too liable to bring disaster in their wake.

It acts if the engineer becomes incapacitated for duty on the engine from any cause, and it is useful and efficient in foggy weather.

The mechanism is compact and easily applied and the whole subject of man failure and the methods of correcting it, are well worth looking into.

#### Standard Railway Equipments.

Special Publication No. 1,577, issued by the Westinghouse Electric and Manufacturing Company, East Pittsburgh, Pa., is devoted to standard railway equipments, and shows a strong trend toward the standardization of types of electric cars and a gradual submerging of the ideas of railway managers and others to the garnered experience of engineers of practical experience with the result that large economies in first cost are being made possible in spite of the higher prices for labor and material. The company is working in the right direction.

#### Daylight Saving Convention.

Preparations are progressing for the "daylight saving" convention to be held in New York City January 30 and 31, to which organizations in all parts of the United States have been invited to send representatives. The executive committee here is headed by Mr. Otto T. Bannard and Mr. Waldo H. Marshall.

#### Lighting.

One bad accident costs more than a good light system, and no bad reflections afterwards.

# Adjustable Crosshead Shoes

## Important Improvement in Their Construction and Easy Method of Keeping Them in a Continuous Perfect Fit

A marked improvement on the method of adjusting crosshead shoes has just been perfected and a patent has been issued to Mr. Charles Markel, locomotive inspector on the Chicago & North Western Railway on the same, and the device bids fair to come rapidly into popular use. It has already become the standard method

another. There is also a saving in the number of the bolts, as only two are used in each shoe while in the old style from four to six were required. Another advantage consists in having a duplicate shoe, which is impossible with fitted bolts, and as the new bolts are not fitted to the holes it can be readily seen how

shown in the drawing is not applied.

In order to obtain the same results to tight crosshead shoes, loose fitting bolts, and, as shown in the second illustration, the end bevel and front bolt is not required, as there is as much spring to the front end of the crosshead as there is at the back, so that by simply planing the old style of crosshead to a 10-in. bevel for shoe fits and re-drilling old bolt holes 15/16 ins., using 1 1/4-in. straight turned or rough bolts, the side fits are pulled into perfect fits, and at the same time the shoe is pulled down on account of the bevel to a perfect fit on the top bearing of the crosshead and shoe. Old crossheads can be converted to the new style of fastening without any change in the pattern being required. All that is necessary, as already stated, is to have the crosshead planed to a 10-in. bevel for the new kind of shoe fits, and applying the new shoes to a slip fit to the replaned crosshead.

As all railways are at considerable expense and delay to engines on account of repairs to crosshead shoes, this marked improvement cannot fail to attract wide attention, and a fair trial under the most strenuous conditions will, it is confidently claimed, lead to a rapid adoption of this important improvement. As is well known, Mr. Markel, the inventor, has already produced many improvements in the mechanical appliances used on railways, including many valuable devices in

on the railroad referred to, and is in use on 100 of their modern passenger and freight engines. They are also converting their old crossheads to the new method as they pass through the shops.

The usual method of holding shoes to crosshead is by reamed holes and fitted bolts, and after from four to eight months of service the crosshead has to be removed from engine and holes reamed and new bolts applied at considerable expense and loss of from eight to ten hours' time of engine. After about six reamings of bolt holes the holes are so large that they have to be welded up and re-drilled to the standard size.

As shown in the first accompanying drawing, the new design of crosshead shoe fastening is by tightening the nuts on two bolts which absolutely grip and pull the shoe to all bearing surfaces. This is caused by the action of bevel fits in place of straight fits, as has always been used, and no amount of tension on nuts will tighten the shoes when the shoe gets slightly loose on the body of fitted bolts. The reaming and fitting of bolts is superseded by using only two bolts, and both being rough or 1/16 in. loose in the holes, consequently the holes will never require enlarging and the crosshead will last as long as the engine and never require a dismantling of piston fit and front end main rod for bolt or shoe work from one period of repair to

easily it is accomplished and how great a saving it is in engine house and shop repairs.

The new style of crosshead and shoe is template planed and jig drilled and is cheaper in construction and more quickly assembled than any other kind of crosshead. The first illustration shows shoe

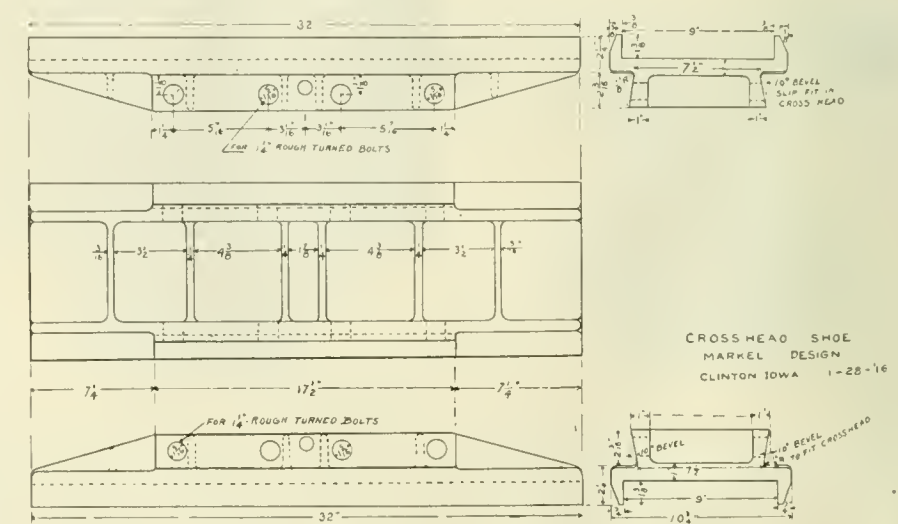

fastening as applied to crosshead when piston is held in its fitted place by the nut and union link connection required to extend below the guides. If the union link connection is so constructed as to be applied at the wrist pin the arm as

construction and repair work, a large number of which have originally appeared in our pages, and met with warm approval. The new crosshead shoe device being patented, it is expected that it will shortly be placed upon the market.

ACCOUNT OF BEVEL NO 3 ON END OF SLIPPERS WHICH ENGAGE BEVEL NO 4 ON CROSSHEAD. TENSION ON 1 1/2 BOLTS NO 1 & 2 PULLS SLIPPERS DOWN AND AGAINST SHOULDERS 3 & 4 ON CROSSHEAD ALSO DOWN ON CROSSHEAD BEARINGS 5 & 6 GIVING IT 40 SQUARE INCHES OF FITTING & BEARING SURFACE

ACCOUNT OF BEVEL NO 9 & NO 10 ON SIDES OF CROSSHEAD. WHEN TENSION IS APPLIED TO 1 1/2 BOLTS NO 7 & 8 PULLS SIDES OF CROSSHEAD IN AGAINST BEVEL ON SLIPPER AND DOWN ON TOP BEARING NO 5 & 6 OF CROSSHEAD GIVING IT 90 SQUARE INCHES OF BEARING SURFACE.

NOTE  
THIS CONSTRUCTION OF HOLDING CROSSHEAD SLIPPERS HAS NO REAMED HOLES OR FIT BOLTS. BOLTS NO 1, 2, 7-8, ARE 1/16 LOOSE IN HOLES, AND ROUGH BOLTS CAN BE USED. VERY LITTLE TENSION ON BOLTS DRAWS THE SLIPPER DOWN AND AGAINST ALL BEARING SURFACE. ACCOUNT OF BEVELS, WHICH ARE VERY EFFECTIVE & WILL KEEP SLIPPERS TIGHT TO CROSSHEAD, IF NOT ALLOWED TO LOOSEN

EXPLANATION OF CROSSHEAD  
MARKEL DESIGN  
PAT. APPLIED FOR C & N W RY CLINTON, IA 4-1-1914

CROSS HEAD SHOE  
MARKEL DESIGN  
CLINTON IOWA 1-28-16



# Electrical Department

## Catechism of the Electric Locomotive Continued

Last month we described and illustrated the schematic main circuit diagram for both a typical A. C. and D. C. locomotive showing with these diagrams the sequence of switches by means of which the passage of the current can be easily traced through the transformers and preventive coils to the motors, in the case of the A. C. locomotive, and through the resistance in the case of the D. C. locomotive.

The catechism to date has covered all of the principal pieces of apparatus with the exception of the main motors. Electric motors in connection with the A. C. and D. C., systems are in general similar so that the following questions pertaining to the motor are applicable to either system.

There are a few minor pieces of apparatus which are used as "Safety First" appliances which we will discuss.

### Safety First.

Q.—In the case of DC locomotives, we

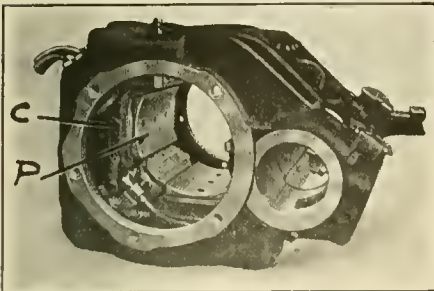

FIG. 25. FRAME OF MOTOR SHOWING HOUSINGS AND ARMATURE REMOVED.

have brought out, in a previous question, that the third rail shoe fuses were supplied to open up any abnormal arc or short circuit which may occur in the locomotive. Will these fuses open under all conditions?

A.—Probably not. It may be possible that an arc being established in the locomotive will not draw sufficient current from the third rail to blow the third rail fuses, but will cause great damage if not interrupted. This arc may occur on the line side of the circuit breaker, so that no current is passing through the overload trip, and thus the arc can not be interrupted by means of the circuit breaker switches.

Q.—What piece of apparatus is sometimes provided to take care of an emergency condition of this kind?

A.—A piece of apparatus is usually supplied, known as a short-circuiting switch.

Q.—What is the construction of this short-circuiting switch?

A.—The short-circuiting switch is nothing more or less than two contacts which are open normally, or, a knife switch which is open in normal operation. In the case of the contacts, these can be operated from the battery circuit, and the closing of them can be controlled by a small emergency switch. In the case of the knife switch, usually this is manually operated, and is located underneath the cab floor, to which is connected a handle and operating rod, so that this switch can be pulled in and closed manually.

Q.—How is this switch connected in the circuit?

A.—The switch is placed between the bus line and ground. One of the contacts is connected to the iron framework of the locomotive which is ground, and the other contact is connected directly to the D.C. bus on the locomotive side of the third rail fuses. When the switch is closed, there is a direct connection between the bus and the ground, so that a large amount of current will flow and the third rail fuses will blow, disrupting the circuit and disconnecting the locomotive entirely from the third rail shoes, thus preventing severe short circuits in the locomotive. This switch is only used in an emergency condition.

Q.—In the case of AC locomotives, what precaution is taken to protect persons getting on to the roof of the locomotive for one reason or another?

A.—Ground hooks are provided, one located at each end of the locomotive.

Q.—How are these ground hooks used?

A.—As the person climbs up the ladder at the end of the locomotive, the first thing encountered is the grounding switch, which either consists of a hook on a chain, the hook to be placed over the pantagraph trolley, or else consists of a device operated by a lever, so that when the lever is thrown, a permanent ground is established to the trolley.

Q.—What is the object of this ground hook?

A.—To permanently ground one of the trolleys, so that in case the other trolley (there are usually two on each locomotive) becomes disengaged from its latch and should raise, touching the trolley, the person on the roof will be protected, since the overhead wire would then become immediately grounded.

Q.—What are the essential parts of a railway motor?

A.—They are the frame, the housings, the bearings, the field coils, the armature and the brush-holders.

### FRAME.

Q.—What is the frame?

A.—The frame, as the word signifies, is the steel casting upon which are built and assembled the electrical and mechanical parts.

Q.—How are these frames usually constructed?

A.—The frames almost invariably are of the "solid" or "box" type but in some locomotives the frames are split. The box frame is of course, mechanically stronger than a split frame due to the fact that it is of one piece. In the split type, bolts are needed to hold the two parts together which is the weak part of this construction and special care must be used to keep these two parts in perfect alignment.

It is not always possible to use the solid frame. Take for instance, the motors on the high speed passenger locomotives operated on the N. Y. N. H.

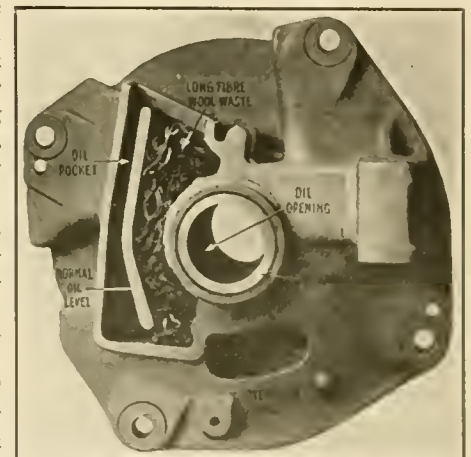

FIG. 26. HOUSINGS WITH SECTIONAL ARMATURE BEARING AND OIL WELL.

& H. R. R.—it is necessary to use a split frame, since the armature or rotating part of the motor is mounted on quills and surrounds the driving axle. It would be impossible to use a solid frame so that the frames of these motors are split in two halves so that they can be assembled around the armature. In the case of some of the later types of locomotives on the N. Y., N. H. & H. the motors are made with solid frames but in this case they are mounted above and not around the axle, so that this type of construction is possible.

A box frame is shown by Fig. 25. As noted, this is a one piece steel casting with large openings bored out at each end for the bearing housings. These openings being of sufficient diameter so that the armature can be removed endwise. It

should be noted that these openings are carefully machined and that in this particular case, means are provided for bolting the housing in place by five large bolts. Inside of the motor is shown the field poles "P," around which are mounted the field coils "C."

HOUSINGS AND BEARINGS.

Q. How is the housing constructed?  
A. A housing with the oil and waste

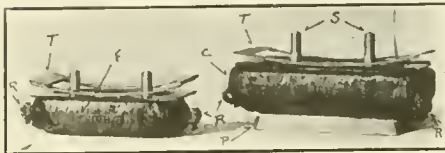

FIG. 27. FIELD COILS AND POLES ASSEMBLED.

compartment sectionalized, is shown by Fig. 26. The lubrication of the armature bearing is of important consideration. Should the armature bearing become over-heated, on account of lack of oil, the bearing, itself, would be damaged in a very short time to such an extent that the space between the armature and the face of the poles, known as the air gap, would be decreased and the armature would rub on the pole faces located in the bottom part of the frame, as the air gap, under normal conditions, is a very small fraction of an inch.

The housing is provided with a separate oil pocket into which the oil is poured and maintained as near as possible and to normal oil level. The oil is carried up by the waste and enters the bearing through the "window" or oil opening as shown. After passing through the bearing it overflows into the overflow pocket. This same system of lubrication is used on the axle bearings or quill bearings as the case may be.

FIELD COILS.

Q. What is the general construction of the field coils and how are they assembled in the frame?

A. The general construction of field coils is shown by Fig. 27. The main pole piece "P" is so shaped that when the main field coil "C" is assembled, as shown in the illustration, it is held firmly in place when the stud bolts "S" are inserted in holes drilled to template in the frame and tightened down by nuts and lock-washers. The inter-pole field "F" is constructed and held in the same manner.

Q. What is the purpose of the flat steel springs "T"?

A. These flat springs are located between the field coil and the frame and are used to prevent all vibrations of the field coils and to take up for any shrinkage of the insulation.

Q. How does the electric current enter the coils?

A. Through the terminals "R." These terminals connect to the copper strap which is wound in coil form and which

makes up the field coil. Each of the turns of copper strap are insulated from each other and the whole is covered by layers of tape, each layer over-lapping as shown.

THE ARMATURE.

Q. What are the essential parts of the armature?

A. The armature is composed of the spider, the core, commutator and the armature winding—all of which are assembled on the armature shaft.

Q. How are these various parts, making up the armature, constructed and assembled.

A. We will consider each part in the order mentioned and show how each go to make up the complete armature.

It is the present practice to use motors which are ventilated so that the maximum possible work can be gotten out of the

coils are made up of turns of copper wire—these wires being placed in the commutator neck slots "T." The coils are held firmly in place by bands of steel wire shown by "W" Fig. 30,—these bands being soldered to retain them in place.

The commutator is one of the most important parts of the armature. It serves as a means of connection between the winding or armature coils and the source of the power. All of the current taken by the motor passes into the commutator and hence into the armature coils. The current entering the commutator through the brushholders and the carbon brushes which we will discuss later.

The commutator is made up of a number of bars corresponding to the number of slots and the number of wires per slot. Each bar is of the same shape—

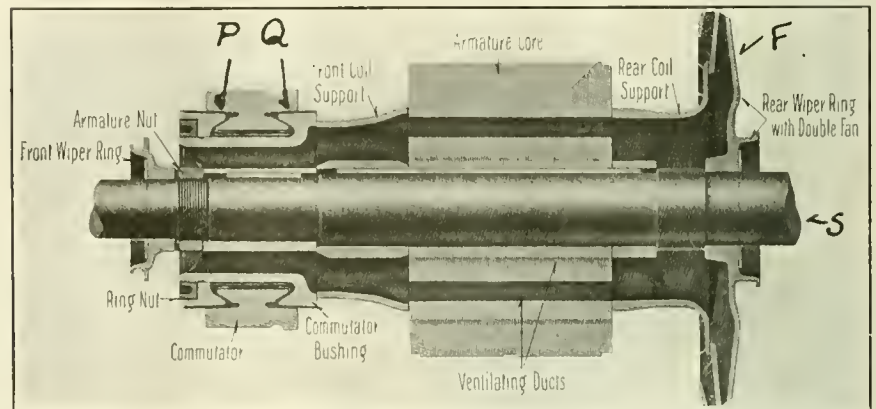

FIG. 28. CROSS SECTION SHOWING ARMATURE PARTS MOUNTED ON SHAFT.

locomotive. The passage of electric current through the windings of the armature results in heat. The amount of heat dissipated, depends on the ventilation of the motor, so that the more air passed through, the harder the motor can be worked for the same temperatures. A great many of the locomotives have the motors cooled by air furnished from an independent blower and in order to aid the passage of air through the motor, same is constructed with a fan on the rear end and ventilating ducts through the core and commutator. This same construction is used without external ventilation and a large increase in power is obtained due to a larger amount of air which can be drawn through the motor thus getting rid of the heat.

Fig. 28 shows a cross section of one of these armatures and Fig. 29, a photograph before the armature is wound. On the shaft "S" is mounted the rear coil support made up of the rear wiper ring and the double fan "F." Through the armature core "C," are the ventilating ducts. These ventilating ducts passing all the way through the front coil support and the commutator "K."

In the slots of the armature core, Fig. 29, are placed the armature coils. These

cross section of which is shown in Fig. 28. As noted, one part is dove-tailed so that when the ring nut is tightened up,

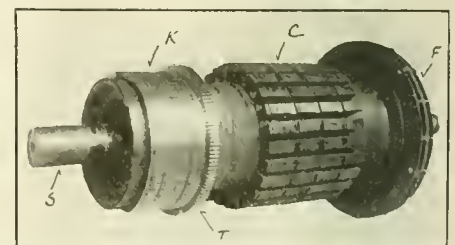

FIG. 29. ARMATURE CORE, COMMUTATOR AND FAN.

the commutator bars are held firmly in position between the ring nut and the commutator bushing. Each bar is insulated on either side by a mica segment a few mills thick and of the same shape as the bar. To prevent these bars grounding on the commutator bushings and ring-nut, moulded mica "V" rings, "P" and "Q" are placed in position before tightening up of the ring-nut.

BRUSH HOLDER.

Q. How are the brush holders constructed?

A. The brush holder is one of the most

important parts of the railway motor and the general construction is shown by Fig. 31. As the name implies, this part of the motor is to carry the brush "T" which is in contact with the commutator and through which current flows into and out of the armature coils. Brushes are blocks of carbon or graphite which fit the holder "A" snugly but not tightly. The brushes can move up and down vertically but should not be loose in the holder.

Q. Does the brush play an important part in the operation of the motor?

A. Yes. The brush can cause much trouble and damage if it is of an improper kind. Excessive wear of the commutator, sparking, flashing, etc., may be caused by the use of an improper brush. Brushes are made in all grades, hard, soft and with different processes of manufacture. Different motors operating under different conditions will require different grades of brushes for the best operation.

Q. Is it essential that the brush-holders be located exactly in the motor?

A. Yes. These brush-holders must be exactly located so as to bring the brushes to exactly the neutral points. To secure this, the clamps which hold the brush-holders are located by template. At the same time these holders must be insulated from the clamps and this is done as follows:—Referring to Fig. 31 the main casting (A) is fitted with two rods about  $\frac{3}{8}$  in. to  $\frac{1}{2}$  in. diameter, over which are placed mica tubes. To protect this insulation a thin brass tube (D) is placed over the mica. Just previous to assembling the brass tubes the corrugated porcelain insulators (E) are put in place and the whole sealed by an insulating compound. The corrugated insulators are to increase the creepage distance from the holder, which has the full voltage, to the brass sleeves which is ground. With this method of clamping the whole holder can be moved up and down and proper clearance obtained between the commutator and the face (F).

Q. How is proper contact obtained between the brush and the commutator?

A. To get proper contact between the brushes and the commutator it is necessary to maintain a pressure on the brushes. This is accomplished by the spiral clock spring (G) made of phosphor bronze or of spring steel, which transmits its pressure to the brush through the hammer (J). Different pressures are required for different conditions and the spring tension can be adjusted by the ratchet (K) and pawl (L). To prevent heating of the spring, and thus loss of tension, a copper braid, called a shunt (M) is provided which conducts the current around the spring or shunts it. One end of this shunt is fastened to the hammer by the rivets (R) and the other to the main holder by rivets (S). The wire which carries the current to the holder

is held in the hole (O) by the screws (P).

#### INSPECTION.

An electric locomotive should receive the same care and inspection as the steam locomotive. It is as essential for the engineer to thoroughly inspect the working parts as on the steam locomotive. Before taking the electric locomotive out on a run, the engineer should be satisfied that it is in running condition and in perfect operation, as far as the electrical circuits are concerned.

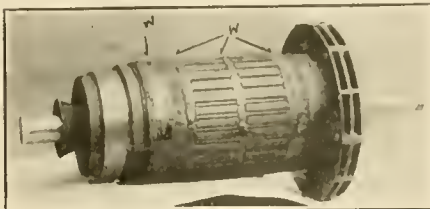

FIG. 30. COMPLETE ARMATURE.

Q.—What procedure is to be followed in getting a "dead" locomotive ready for service?

(The following answers are applicable to an A.C.-D.C. locomotive.) In case of either a straight A.C. or a straight D.C. locomotive, the points not applying to that type can be omitted.)

A. FIRST, see that the ground hooks are removed from each trolley; SECOND, cut in the auxiliary switches. This should cover the battery switches, the switch for starting the motor generator, the compressor and blower switches, and allow the compressor to pump up the reservoir to the

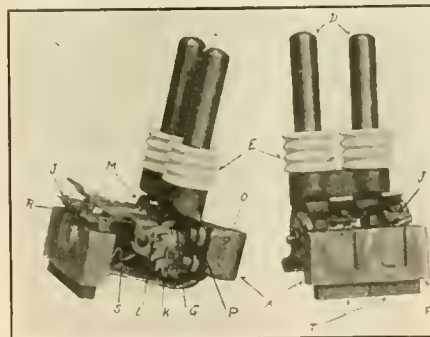

FIG. 31. BRUSH HOLDER.

operating pressure, usually 130 lbs. for high speed or freight service, and note that governor cut outs at right pressure; FOURTH, see that all hose angle cocks, conductors, emergency valves, the main reservoir bleed cocks and supplementary and control reservoir bleed cocks are closed. FIFTH, test each trolley, raising and lowering; SIXTH, test headlights, cab light; SEVENTH, test the motor generator set, and be sure it is operating from the power supply and not feeding back from the battery. This is accomplished by disconnecting the motor generator set from the battery; EIGHTH, test the battery. A small light is usually provided for testing and should burn brightly if battery is fully charged; NINTH, in addition to

raising and lowering of the trolleys, try the other push buttons on the master controller, which raise and lower the third rail shoes, reset the circuit breaker, operate the sanders, etc.; TENTH, test the sequence of switches. This is a very important matter, as the switches must follow a definite sequence in order to obtain correct operation of the locomotive, and the engineer should become familiar with the order of the switches; ELEVENTH, examine third rail shoes, shoe beams, etc.

#### Official Changes in the Westinghouse Air Brake Company.

At the annual meeting of the stockholders of the Westinghouse Air Brake Company, the position of chairman of the board was created and filled by the election of Mr. H. H. Westinghouse. Mr. John F. Miller, formerly first vice-president, was elected to the office of president.

Mr. Miller is a native of Pittsburgh, and received his early education in the public schools of that vicinity. Upon his graduation from Wooster Academy, he became connected with the Westinghouse interests, and did his first Westinghouse work for the Philadelphia Company of Pittsburgh. He later took charge of the real estate development of East Pittsburgh and Wilmerding as conducted by the Westinghouse companies, and subsequently was identified with important banking and public utility interests. In 1899 he was made assistant secretary of the Westinghouse Air Brake Company. His fitness for large responsibility resulted in his being made vice-president in 1905, including, among his other duties, special attention to the organization and development of the company's interests abroad. Mr. Miller's broad experience, sound judgment and conservative temperament as a banker, financier and accountant qualify him particularly for his new position.

Mr. A. L. Humphrey, formerly second vice-president and general manager, was made first vice-president and general manager of the company. Mr. Humphrey's career and achievements as a railroad official and general manager of the Westinghouse Air Brake Company are so well known to railway officers and manufacturers as to need no detailed mention.

Mr. Charles A. Rowan, heretofore auditor, was promoted to the position of controller, and Mr. John H. Eicher, formerly assistant auditor, was made auditor of the company.

The Chicago Burlington & Quincy reported as ordering 25,000 tons of rails for delivery in 1918, has ordered 40,000 tons. Contract has also been awarded to the American Bridge Company for 3000 tons of structural steel for the new freight house at Chicago.

# Eminent Living Railway Men

## Frederick Douglas Underwood, President of the Erie Railroad

The New York *Sun* recently published a biographical sketch of Frederick Douglass Underwood, president of the Erie Railroad, part of which reads:

Mr. Underwood was born in Wauwatosa, Wis. His father was a Baptist minister, a learned man who knew many things and failed to do enough in this life to make a living. The son, however, learned many a lesson both by precept and contrast in the straggling parsonages which his parents had in the Badger State, and applied the lessons to his conduct. When he got through his studies in his teens he found a job as driver for an ore cart in a Wisconsin copper mine at Fort Howard for several months. Then his horse bolted and smashed up the cart, for this was the first and probably the last time that Frederick D. Underwood failed to hold anything. After that he went to work as a miner and was doing very well, for a well built, broad-shouldered youth as he was could not help but make good in any heading.

So far he had not applied his education, only his general high intelligence, but his chance soon came. There was another cart driver by the name of Johnson, to whom was offered the foremanship of a grain elevator by the old Chicago and North Western Railroad. He declined it because he could not write anything but his own name and recommended young Underwood for the place.

His theory of life was that every man should know all that there was to be known about one thing—his work. All else in the way of useful information which might be picked up he considered of value but subordinate to the main chance. While he was mastering the ways of the railroad he was also studying men and learning how to get out of them not only work but the best there was in them.

He went into the service of the Chicago, Milwaukee and St. Paul Railroad, which took him to Milwaukee to live. This brought him in touch with the life of a growing urban community. He took a larger view and studied the science of railroading and the development of natural resources. His remarkable grasp of essential facts won quick promotions. On the Chicago, Milwaukee and St. Paul, where he worked for eighteen years, he eventually became division superintendent.

We find him in 1886 the manager of the Minneapolis and Pacific Railway, from which he went to become the general manager of the Minneapolis, St. Paul and Sault Ste. Marie Railway, the old Washburn system, better and more popularly known to many as the Soo Line.

In that new field he came in contact with a mighty man, a Titan, of the West, the late James J. Hill, of the St. Paul, Minneapolis and Manitoba. When two strong men meet for the first time there is likely to be a fight.

The forces of rival roads, pushing ahead on the prairies of Dakota, each claiming in one section practically the same right of way, came into armed collision. Mr. Underwood supported his cause with rifles in the hands of his hardy crews. He would not yield, and it goes without saying that neither would Hill.

It was a war of the long lines car-

of the property of the much abused Erie and then told what ought to be done, how many millions ought to be spent in doing it, and when pressed for further details said that he was willing to begin the work of his life—for \$50,000 a year. His terms were accepted by the men in control and the regeneration of the ancient railroad began.

He recognized that although as a passenger road the Erie had been somewhat remiss, it had wonderful possibilities as a freight line, for it tapped some of the best and richest territory of the East. He knocked the directors of those days off their feet, bowled them over gasping, when he announced at one of the first meetings that he was actually going to see to it that real money was going to be spent on the Erie.

There are various accounts in Wall Street circles of that conclave. Such details as painting tool sheds if it could not be avoided and making repairs long overdue were being drowsily discussed. Mr. Underwood picked up a pen and wrote rapidly on a sheet of paper. When he was asked for his opinion he rose quickly to his feet.

"I am surprised, gentlemen," he is reported to have said, "that you are wasting your time on details which any man under me for \$2 a day could pass upon. If he could not, he would not be worth the \$2, and I would fire him."

"You have paid large sums to engineers who have reported to you that certain things must be done for the future of this railroad. I have their recommendations and reports here before me. I have examined the property thoroughly, and I approve every one of these recommendations."

"You have engaged me at a large salary to do what I can to build up this railroad. As far as I am concerned this matter will soon be settled. This letter which I hold is my resignation. I shall leave these papers with you and retire. It is up to you either to adopt the recommendations of the engineers or to accept my resignation."

Three minutes after Mr. Underwood left he was called back and informed by the board that it had unanimously decided to accept the report of the engineers and would not hear of his resignation.

This brings us to the new era of the Erie. The Pegasus of the critics grew limp and weary. Things began to happen. Mr. Underwood got \$10,000,000 for improvements at the start, and the total sum which eventually will be spent in the recrudescence is about \$35,000,000.

The hauling of the great trains of



FREDERICK D. UNDERWOOD.

ried on for weeks, and finally when a truce was signed it came to pass that Frederick D. Underwood had not made an enemy but a friend who was to exert a powerful influence on his destiny. James J. Hill, the builder of the Empire of the West, knew a real man when he saw him, for he was one who had reared a mighty fabric on that gift.

Fifteen years ago the late J. Pierpont Morgan and James J. Hill had a conference in an office not far from Broad and Wall streets with regard to the affairs of the Erie Railroad. The Titan of the West told the financier what he thought about Underwood.

"We will send for him," said Mr. Morgan.

The general manager of the Baltimore and Ohio made a two weeks' inspection

freight was put on an economic basis by reducing grades and putting in cut offs. Tracks level, straight and easy to travel, did wonders for the old path of iniquity. It was no longer a hard road to travel. Energetic young men were out in every direction getting new business, and they brought it in by the bale.

One of the secrets of the continued success of Frederick D. Underwood is in the fact that he has never got out of touch with the mechanical side of the business. He has had his troubles about wages and has been the storm center of heated discussions, but he has never lost his perspective nor his head.

His passing over the various lines on his tours of inspection to-day is looked forward to by the employees not as an ordeal but as a pleasure for all concerned. Here is the chance to talk things over with the "boss," to make suggestions and to get information on his views.

In that brief sentence there is a great deal of the philosophy on which Frederick Underwood has built his life. He looks on the honest toil as useful and honorable. He is the champion of useful manual labor. It is his belief that there are too many men in the so-called learned professions earning small salaries and looking with a lingering contempt on the workers who achieve with their hands.

Although he himself completed little more than a preparatory course, he is a great believer in college training and is frankly of the opinion that in railroading and in all great industrial enterprises the man with the diploma will have a larger part. He especially has decried the idea that men of force succeed because they have had no academic degree. Since he gave expression to such views as these, many of the larger universities have actually adopted courses to train young men for business and industrial administration.

He promoted the establishment of mechanical schools for the apprentices connected with all the repairs shops of the company, and there are six of them now in operation.

Mr. Underwood is interested in many other things besides railroading. His favorite amusement is yachting and he belongs to several clubs devoted to that sport. He is also fond of recreation at the seashore, and it has been solemnly averred that one season at Palm Beach he was voted the best dressed man at that resort, special praise being bestowed upon his silken shirts and his pongee suit and up-to-date Panama hat.

His home is at 277 West End avenue, New York City, not far from the residence of Charles M. Schwab. He works long and hard, but he does not lose sight of the lighter side of life, and through all that he does he shows his genius for friendship and his genial interest in all mankind.

## Welding Tool Steel Tips to Machine Steel Shanks

The constantly increasing price of high-speed tool steel now makes it almost prohibitive for the average shop to use cutting tools composed wholly of such material. Furthermore, with high-speed steel at present prices, it is very costly for a shop to have to scrap worn out tools. Such problems, however, can be solved and noticeable economies effected by welding high-speed steel tips to ordinary machine-steel shanks. Thus old worn out high-speed steel tools can be cut to proper size and utilized for tips and this brings with it a great saving.

Briefly, the process for welding tips to shanks for tool steel is as follows: The high-speed steel tip is first "tacked" to the machine-steel shank, and the whole is heated. After fluxing with borax, welding is begun. After welding, the tool is immediately laid in mica dust to gradually cool. It is then given a first grinding and is tempered, after which the finish grinding is accomplished, when the tool is ready for use. Thus the process is a simple one. The illustration shows the various steps in the process—No. 1, "tacked" to shank; No. 2, tool after welding; No. 3, as it appears after first grinding, and No. 4, the tool ready for use, after tempering and finish grinding. Tool designated No. 5 was tested for strength of weld by hammering, and it broke above the weld. The reinforcing metal which is built out and around the tip, serves both

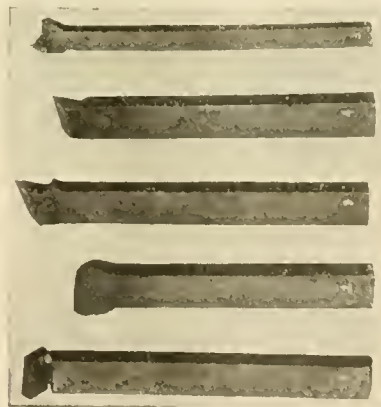

FIG. 1.  
HIGH SPEED TOOL STEEL WELDED TO SHANKS.

to give larger radiating surface and to afford a larger conducting path back to the butt of the tool, thus keeping down the temperature at the cutting edge when in use. The machine-steel shank may be of any length desired, and of cold, hot rolled, or carbon steel, while the high-speed steel tip should be short.

The Westinghouse Electric & Mfg Company of East Pittsburgh, Pa., which is at the present time using cutting tools with high-speed steel tips and machine-

steel shanks for many of its planers and lathes, has found the electric arc process of welding very satisfactory, and much cheaper than any other process. This conclusion has been reached after tests employing other methods. The ordinary electric arc welding equipment made by that company may be used, and is the same as that required for the welding or repair of castings. For the best results the current for this work should be ap-

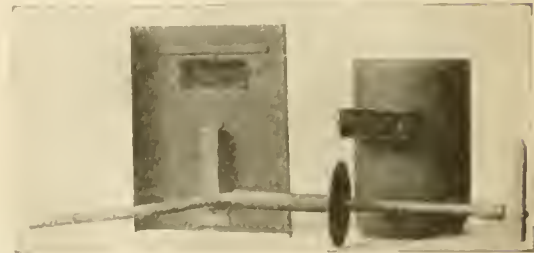

FIG. 2.  
SHIELD FOR OPERATOR AND CARBON HOLDER

proximately 100 amperes, and the voltage of the welding circuit 60-70 volts. A 5-32 in Norway iron electrode should be used. The work should not be hurried, but a good operator can make between 25 and 30 welds for tools of 1 1-2 in. cross section in a day of 9 1-2 hours.

### Harrison Dust Guards.

Harrison dust guards, manufactured and sold by the Harrison Specialties Company of Chicago, Ill., have been specified on the 5,000 New York Central cars recently ordered. Dust guards to equip 16,750 cars have been sold by this enterprising company in the past two and one-half months.

### New York Subway Extension.

The New York Public Service Commission, first district, will close bids on December 4, for the construction of station finish for nine stations on the Seventh avenue section of the Seventh avenue-Lexington avenue line in the borough of Manhattan. These stations are between Fourteenth street and the Battery.

### New Station at San Antonio, Tex.

The Missouri, Kansas & Texas will erect a new passenger station at San Antonio. The building will be one story high, 245 ft. long and 77 ft. wide. The structure will be fireproof throughout with stucco or brick, built mission style and have mission towers. The platform along the passenger tracks will be 850 ft. in length, and covered with umbrella sheds. The cost will be about \$125,000.

# Items of Personal Interest

Mr. J. J. Dowling has been appointed master mechanic of the Great Northern, with office at Delta, Wash.

Mr. C. R. Burns has been appointed road foreman of engines on the Baltimore & Ohio, with office at Mars, Pa.

Mr. H. F. Curry has been appointed road fireman of engines on the Baltimore & Ohio, with office at Foxbury, Pa.

Mr. M. F. Clements has been appointed bridge engineer on the Northern Pacific, with headquarters at St. Paul, Minn.

Mr. F. B. Zercher has been appointed master car builder on the Grand Trunk, succeeding Mr. A. Capony, resigned.

Mr. A. Macdonald has been appointed master mechanic of the Stratford shops of the Grand Trunk, with office at Stratford, Ont.

Mr. Edwin G. Foster, formerly assistant engineer of the Buffalo, Rochester & Pittsburgh, has been appointed valuation engineer, with headquarters at Rochester, N. Y.

Mr. William J. Tracy has been appointed superintendent of the system shops of the Lehigh Valley with office at Sayre, Pa., succeeding Mr. J. C. Seeger, resigned.

Mr. W. M. Neal has been appointed acting superintendent of car service of the Canadian Pacific with office at Montreal, Que., succeeding Mr. H. J. Humphrey, transferred.

Mr. J. R. Alexander, formerly general road foreman of engines of the Eastern division of the Pennsylvania Railroad, has been promoted to a similar position with office at Pittsburgh, Pa.

Mr. John D. Rogers, formerly round house foreman of the Oregon Short Line at Pocatello, Idaho, has been appointed shop superintendent of the Virginia with office at Princeton, W. Va.

Mr. R. J. McDonald, formerly traveling engineer on the Southern district of the Chicago & Alton, has been appointed train master on the same road with headquarters at Roadhouse, Ill.

Mr. Frank L. Pierce, formerly locomotive, engineer on the Chicago & Alton has been appointed traveling engineer on the Southern district of the same road with headquarters at Bloomington, Ill.

Mr. C. E. Denney, formerly assistant to the president of the Union Switch & Signal Company, has been appointed special engineer of the New York, Chicago

& St. Louis with headquarters at Cleveland, Ohio.

Mr. A. B. Ford has been appointed master mechanic of the Butte division of the Great Northern, with office at Great Falls, Mont., succeeding Mr. F. M. Fryberg, recently appointed, but now on leave of absence.

Mr. Charles A. Lemmin, formerly chief engineer of the Butte Anaconda & Pacific has been appointed assistant to the general manager of the Anaconda Copper Mining Company, with office at Anaconda, Mont.

Mr. J. P. Landreth, formerly Chicago manager of the Garlock Packing Company, Palmyra, N. Y., has been appointed western sales manager of the Anchor Packing Company, Philadelphia, Pa., with headquarters at Chicago.

Mr. Hugh E. Greer, formerly sales agent for the Union Railway Equipment Company, Chicago, Ill., has been appointed general sales representative of the Camel Company, manufacturer of railway specialties, with headquarters in Chicago.

Mr. F. A. Hussey, formerly road foreman of engines on the Boston & Albany at Allston, Mass., has been appointed master mechanic of the Boston division of the same road, with office at Beacon Park, Allston, succeeding Mr. F. A. Butler.

Mr. Sydney Dillon has been appointed chief mechanical engineer of the Carnegie Steel Company, succeeding Mr. John Hulst, who has been appointed assistant to the vice-president and chief engineer of the United States Steel Corporation.

Mr. T. J. Rayeroft, formerly assistant master mechanic of the Cumberland division of the Baltimore & Ohio, has been appointed master mechanic of the Wheeling division of the same road, with office at Wheeling, W. Va., succeeding Mr. J. Blessing, resigned.

Mr. F. A. Butler, formerly master mechanic of the Boston division of the Boston & Albany, at Beacon Park, Allston, Mass., has been appointed master mechanic of the Albany division of the same road, with office at West Springfield, Mass., succeeding Mr. A. B. Canfield, assigned to other duties.

Mr. C. E. Bess, formerly assistant foreman of the South Pacific at Rosedale, Cal., has been appointed assistant master mechanic on the same road, with office at Sparks, Nev., succeeding Mr. Paul Jones, who has been appointed a member of the efficiency committee of the company, with headquarters at San Francisco, Cal.

Mr. W. P. Barba, formerly vice-president of the Midvale Steel Company, Worth Brothers Company and the Wilmington Steel Company, has resigned, and is succeeded by Mr. E. E. Slick, vice-president of the Cambria Steel Company. Mr. Barba has been in the employ of the Midvale Steel Company for 36 years.

Mr. William A. Duff, formerly engineer of bridges of the Canadian Government Railways at Moncton, N. B., has been appointed assistant chief engineer, and in addition to his duties as engineer of bridges will have charge of the Halifax Ocean Terminals and will perform such other work as may be assigned by the chief engineer.

Mr. R. H. Wood, formerly with the Buffalo office of the Warner & Swasey Company, Cleveland, Ohio, has been appointed manager of the Chicago district office of the Modern Tool Company, Erie, Pa. Mr. Leo C. Steinle has been appointed direct representative in France of the Modern Tool Company, with offices at Paris and Lyons. Mr. Steinle is actively connected with the Steinle Turret Machine Company, Madison, Wis., whose interests he is also looking after abroad.

Mr. Norman L. Warford, formerly in charge of the Powdered Coal Department of the Anaconda Copper Mining Company, Anaconda, Mont., has become identified with Powdered Coal Engineering and Equipment Company of Chicago, Ill., in the capacity of engineer in charge of construction. Mr. Warford is credited with having installed the largest powdered coal plant in the United States for the Anaconda Mining Company at its several works, where they burn approximately 1,000 tons of pulverized coal daily.

Mr. C. J. Burkholder, formerly general road foreman of engines of the Kansas City Southern, has accepted a position with the Economy Devices Corporation, as mechanical representative in the Western territory, with headquarters at Kansas City. Mr. Burkholder was born May 8, 1875. His entire business life, up to his recent appointment, has been spent in railroad work. Starting in the roundhouse of the Pennsylvania Railroad at Tyrone, his next step was locomotive fireman on the same road. Leaving the Pennsylvania he went as locomotive fireman for the Union Pacific, and was later promoted to locomotive engineer. He resigned from the Union Pacific and went as locomotive engineer to the Kansas City Southern, Northern Division. He was in turn promoted to traveling engineer, train master and general road foreman of engines, which position he held at the time of his recent appointment.

## OBITUARY.

## Theodore Newell Ely.

The death of Mr. Theodore Newell Ely removes one who was long a prominent figure in railroad work. He was a graduate of the Rensselaer Polytechnic Institute, Troy, N. Y., as civil engineer. He entered railway service in 1868 in the engineering department of the Fort Wayne & Chicago Railway at Pittsburgh, Pa., and shortly afterwards was appointed assistant engineer on the Philadelphia & Erie division of the Pennsylvania Railroad. In 1869 he was appointed superintendent of the middle division of the same road, and assistant general superintendent in 1870, and in 1873 superintendent of motive power on the same division. From 1874 to 1882 superintendent of motive power of the Pennsylvania division, and from 1882 to 1893 general superintendent of motive power, Pennsylvania lines East of Pittsburgh, and from 1893 to 1911 chief of motive power of the entire Pennsylvania System. He was born at Watertown, N. Y., in 1846.

## Amos Willetts Wright.

Among the notable newspaper men who have lately passed away was Amos Willetts Wright who died at his home in Eighty-first street, New York, on November 6, in the 70th year of his age. He was a brother of Dr. Jonathan Wright of Pleasantville, N. Y.

Amos W. Wright was a graduate of Dartmouth College which he passed through with high honors, having made a specialty of history, literature, and political economy. On graduating he determined to enter the newspaper field, became proprietor and editor of the Fort Wayne *Gazette*, which he controlled for several years. He married Dorothy Head, of Kenosha, Wis., daughter of Orson Sherman Head, a celebrated lawyer.

Finding that the Fort Wayne *Gazette* offered a scope too limited to suit his ambition Mr. Wright went upon the editorial staff of the *Inter Ocean* of Chicago, which was changed successively for the *Globe-Democrat* of St. Louis, the *Milwaukee Sentinel* and the *New York World*, when the latter journal was managed by Mr. Joseph Pulitzer. As a leader and editorial writer Mr. Wright was distinguished for sound policy, unflinching honesty and charm of style. As a man he possessed the rare qualities of keen humor, gentleness and stability in his contact with the world. As a friend his qualities may be summed up in the simple words of one who had known him for fifty years—he never had an enemy and he never lost a friend.

## William Cooper Cuntz.

Much regret has been expressed at the death of William C. Cuntz, general mana-

ger and director of the Goldschmidt Thermit Company, of 120 Broadway, New York, at the comparatively early age of 45 years. A year ago he was operated upon for appendicitis, and never completely recovered his health. He was a graduate of the Stevens Institute, taking the degree of mechanical engineer in 1892, and became connected with the Pennsylvania Steel Company as resident engineer in Boston, Mass., and afterwards in London, England. Among the more notable operations with which he was connected were the erection of the North and South stations in Boston, and the North German Lloyd piers in Hoboken, New Jersey. His services were also much appreciated as assistant general sales manager in Philadelphia, and as district sales manager at Steelton, Pa. In 1898, at the outbreak of the Spanish-American War, he volunteered for service in the artillery. In 1910 he was appointed a delegate to the International Railway Congress at Berne,



WILLIAM COOPER CUNTZ.

Switzerland. In the same year he severed his connection with the Pennsylvania Steel Company to become a director and general manager of the Goldschmidt Thermit Company in New York. Under his able management the increase in the company's business was rapid, and marked progress was also made in the development of the Thermit process, and it is universally acknowledged that it is largely due to his skill and perseverance that the manufacture of carbon-free metals and alloys are coming into general use. He was an active member of over twenty of the leading engineering and other societies, and among his many duties he found time to take a leading part in the civic welfare of the community where he lived. Mr. Cuntz was of revolutionary stock, and his character was marked by many of the fine features that distinguished the race from which he sprung.

## Harry Monkhouse.

Harry Monkhouse, one of the pioneer railroad motive power men of this country, died at St. Paul, Minn., last month. Mr. Monkhouse was born seventy-two years ago in the State of Ohio. As a young man he learned the machinist's trade on the Central Ohio. In 1869 he became foreman of the shops at Newark, Ohio, when this road was taken over by the Baltimore & Ohio. He later went to the Manitoba Railroad, with headquarters at St. Paul and was master mechanic for a number of roads. For a time he went into business for himself and later was engaged with railway supplies. He returned to railroad service and became general foreman of the Rock Island, with headquarters at Harrington, Kas., in 1888, from which position he was promoted in 1889 to assistant superintendent motive power in charge of Lines West of the Missouri River. In 1898 he became superintendent motive power of the Chicago & Alton, which position he resigned in 1900 to become superintendent motive power of the Chicago, Indianapolis & Louisville, with headquarters at Lafayette, Ind. In September, 1901, he became general manager of the Rome Locomotive & Machine Works at Rome, N. Y., and in February, 1902, was elected president of that company, which position he resigned in August, 1915, on account of ill health.

## List of Committees and Subjects for the American Railway Master Mechanics' Association for the Convention of June, 1917.

The following is the list of standing and special committees and the subjects submitted to them for the next convention of the Master Mechanics' Association. Special instructions have been issued by Mr. Joseph W. Taylor, secretary, that advance copies of the various reports and individual papers must be in the hands of the members a month before the convention, therefore, all papers and reports should be in the secretary's hands before April 15, 1917.

## STANDING COMMITTEES.

- Standards and Recommended Practice: W. E. Dunham (Chairman), Supr. M. P. & M., C. & N. W. Ry. Winona, Minn.; M. H. Haig, M. E., A. T. & S. F. Ry., Topeka, Kan.; A. G. Trumbull, Asst. to G. M. S., Erie R. R., New York City; C. D. Young, Engr. Tests, Penna. R. R., Altoona, Pa.; G. S. Goodwin, M. E., C. R. I. & P. Ry., Chicago, Ill.; R. L. Ettinger, C. M. E., Southern Ry., Washington, D. C.; B. B. Milner, Engr. M. P., N. Y. C. R. R., New York City
- Mechanical Stokers: A. Kearney (Chairman), A. S. M. P., N. & W. Ry., Roanoke, Va.; M. A. Kinney, S. M. P., Hocking Valley R. R., Columbus, Ohio; J. R. Gould, S. M. P., C. & O. Ry., Rich-

mond, Va.; J. T. Carroll, A. G. S. M. P., Balto. & Ohio R. R., Baltimore, Md.; J. W. Cyr, S. M. P., C. B. & Q. Ry., Chicago, Ill.; A. J. Fries, A. S. M. P., N. Y. Central Lines, Depew, N. Y.; L. B. Jones, A. E. M. P., Penna. R. R., Williamsport, Pa.

3. Fuel Economy and Smoke Prevention. Wm. Schlafge (Chairman), G. M. S., Erie R. R., New York City; W. H. Flynn, S. M. P., Mich. Central R. R., Detroit, Mich.; D. M. Perine, S. M. P., Penna. R. R., New York City; Robert Quayle, G. S. M. P. & C., C. & N. W. Ry., Chicago, Ill.; D. J. Redding, A. S. M. P., P. & L. E. R., McKee's Rocks, Pa.; W. J. Tollerton, G. M. S., C. R. I. & P. Ry., Chicago, Ill.; F. H. Clark, G. S. M. P., B. & O. R. R., Baltimore, Md.

4. Powdered Fuel: C. H. Hogan (Chairman), A. S. M. P., N. Y. C. R. R., Albany, N. Y.; E. W. Pratt, A. S. M. P., C. & N. W. Ry., Chicago, Ill.; Thos. Roope, S. M. P., C. B. & Q. R. R., Lincoln, Neb.; J. H. Manning, S. M. P., D. & H. Co., Watervliet, N. Y.; Charles James, M. S., Erie R. R., Youngstown, Ohio; G. L. Fowler, 83 Fulton street, New York City; W. L. Kellogg, S. M. P., M. K. & T. Ry. Denison, Tex.; O. S. Beyer, University of Illinois, Urbana, Ill.

5. Specifications and Tests for Materials: C. D. Young (Chairman), Engr. Tests, Penna. R. R., Altoona, Pa.; J. R. Onderdonk, Engr. Tests, B. & O. R. R., Baltimore, Md.; A. H. Fetters, M. E., Union Pac. Ry., Omaha, Neb.; Frank Zeleny, Engr. Tests, C. B. & Q. R. R., Chicago, Ill.; H. E. Smith, Engr. Tests, N. Y. C. R. R., Collinwood, Ohio; H. B. MacFarland, Engr. Tests, A. T. & S. F. Ry., Chicago, Ill.; Prof. L. S. Randolph, Virginia Polytechnic Institute, Blacksburg, Va.

#### SPECIAL COMMITTEES.

6. Design and Maintenance of Locomotive Boilers: C. E. Fuller (Chairman), S. M. P., Union Pacific R. R., Omaha, Neb.; A. W. Gibbs, C. M. E., Penna. R. R., Philadelphia, Pa.; D. R. MacBain, S. M. P., New York Central R. R., Cleveland, Ohio; M. K. Barnum, S. M. P., Balto. & Ohio R. R., Baltimore, Md.; R. E. Smith, G. S. M. P., Atlantic Coast Line R. R., Wilmington, N. C.; C. B. Young, M. E., Chgo. Bur. & Quincy R. R., Chicago, Ill.; J. Snowden Bell, New York City.

7. Locomotive Headlights: D. F. Crawford (Chairman), G. S. M. P., Penna. Lines, Pittsburgh, Pa.; C. H. Rae, G. M. M., L. & N. R. R., Louisville, Ky.; F. A. Torrey, G. S. M. P., C. B. & Q. R. R., Chicago, Ill.; H. T. Bentley, S. M. P. & M., C. & N. W. Ry., Chicago, Ill.; M. K. Barnum, S. M. P., Balto. & Ohio R. R., Baltimore, Md.; Henry Bartlett, G. M. S., B. & M. R. R., Boston, Mass.; W. H. Flynn, S. M. P., Mich. Central R. R., Detroit, Mich.; W. O. Moody, M.

E., Illinois Central R. R., Chicago, Ill.; A. R. Ayers, Engr. R. S., N. Y. C. R. R., New York City.

8. Superheater Locomotives: W. J. Tollerton (Chairman), G. M. S., C. R. I. & P. Ry., Chicago, Ill.; H. W. Coddington, Engr. Tests, N. & W. Ry., Roanoke, Va.; C. H. Hogan, A. S. M. P., N. Y. C. & H. R. R., Albany, N. Y.; R. W. Bell, G. S. M. P., Ill. Cent. R. R., Chicago, Ill.; T. Roope, S. M. P., C. B. & Q. R. R., Lincoln, Neb.; W. C. A. Henry, S. M. P., Penna. Lines, Columbus, Ohio; E. W. Pratt, A. S. M. P., C. & N. W. Ry., Chicago, Ill.; G. M. Basford, 30 Church street, New York City.

9. Design, Maintenance and Operation of Electric Rolling Stock: C. H. Quereau (Chairman), New York Central R. R., New York City; G. C. Bishop, S. M. P., Long Island R. R., Richmond Hill, L. I., New York City; G. W. Wildin, M. S., N. Y. N. H. & H. R. R., New Haven, Conn.; J. H. Davis, E. E., B. & O. R. R., Baltimore, Md.; R. D. Hawkins, S. M. P., Great Northern Ry., St. Paul, Minn.; A. E. Manchester, S. M. P., C. M. & St. Ry., W. Milwaukee, Wis.; T. W. Heintzelman, G. S. M. P., Southern Pacific Co., San Francisco, Cal.; J. T. Wallis, G. S. M. P., Penna. R. R., Altoona, Pa.; J. E. Pilcher, M. E., N. & W. Ry., Roanoke, Va.

10. Co-operation with Other Railway Mechanical Organizations: D. R. MacBain (Chairman), S. M. P., New York Central R. R., Cleveland, Ohio; E. W. Pratt, A. S. M. P., C. & N. W. Ry., Chicago, Ill.; C. A. Shaffer, G. T. I., Illinois Central R. R., Chicago, Ill.; F. J. Barry, M. M., N. Y. O. & W. Ry., Childs, Pa.; E. S. Fitzsimmons, M. S., Erie R. R., New York City, N. Y.; F. C. Pickard, M. M., D. L. & W. R. R., Buffalo, N. Y.

11. Train Resistance and Tonnage Rating: O. C. Wright (Chairman), A. E. M. P., Penna. Lines, Ft. Wayne, Ind.; H. C. Manchester, S. M. P., D. L. & W. R. R., Scranton, Pa.; C. E. Chambers, S. M. P., C. R. R. of N. J., Jersey City, N. J.; J. H. Manning, S. M. P., D. & H. Co., Watervliet, N. Y.; Frank Zeleny, Engr. Tests, C. B. & Q. R. R., Aurora, Ill.; Prof. E. C. Schmidt, University of Illinois, Urbana, Ill.; Jos. Chidley, A. S. M. P., N. Y. C. R. R., Cleveland, Ohio; J. T. Carroll, A. G. S. M. P., B. & O. R. R., Baltimore, Md.

12. Springs—Shop Manufacture and Repair, Including Design, Appliances and Repair: M. F. Cox (Chairman), A. S. M., L. & N. R. R., Louisville, Ky.; Eliot Sumner, S. M. P., Penna. R. R., Williamsport, Pa.; A. G. Trumbull, Asst. to G. M. S., Erie R. R., New York City; E. W. Pratt, A. S. M. P., C. & N. W. Ry., Chicago, Ill.; T. A. Foque, G. M. S., M. St. P. & S. S. M. Ry., Minneapolis, Minn.; C. A. Gill, G. M. M., B. & O. R. R., Baltimore, Md.; G. W. Rink, M. E., C. R. R. of N. J., Jersey City, N. J.

13. Subjects: M. K. Barnum (Chair-

man), S. M. P., B. & O. R. R., Baltimore, Md.; D. R. MacBain, S. M. P., New York Central R. R., Cleveland, Ohio; C. E. Fuller, S. M. P., Union Pacific R. R., Omaha, Neb.

14. Arrangements: Wm. Schlafge, G. M. S., Erie R. R., New York City; C. E. Chambers, S. M. P., C. R. R. of N. J., Jersey City, N. J.; E. H. Walker, Standard Coupler Co., New York City.

Individual Papers: Feed Water Heaters, J. Snowden Bell. Welding Locomotive Tubes, Fire Box and Boiler Sheets, D. R. MacBain.

#### American Railway Association.

The American Railway Association held several sessions in New York last month, instead of Denver as originally arranged. The chief discussions were in the ways and means to relieve the freight congestion. Reports of the names and numbers of cars detained and the reasons were reported.

#### Boiler Code Hearing.

A public hearing on the Boiler Code will be held in the Engineering Societies Building, beginning December 2, at 2 P. M., and continue into the following week, if necessary. This meeting is in accordance with the work of the permanent committee authorized to make such revisions as may be found desirable, and to modify the same as the cost advances. The meeting follows the annual meeting of the American Society of Mechanical Engineers.

#### Memorial Tablet to William O'Herin.

On October 7 a memorial tablet to the late William O'Herin was erected near the general offices of the Missouri, Kansas & Texas Railway, before a gathering of more than 10,000 employees of the railway. Mr. O'Herin was born in the County of Limerick, Ireland, on January 6, 1846. With his parents he emigrated to New York in 1848. His first position was with the New York Central as a machinist. Afterwards he became a fireman and a locomotive engineer with the same railway. He went West in 1873, at the time the Missouri, Kansas & Texas Railway was built. He entered the employ of this corporation as an engineer and was promoted shortly afterwards to the position of foreman of a roundhouse. In 1884 he was made master mechanic of the System. Later he was superintendent of machinery and equipment, which position he occupied for many years and finally was promoted to the office of assistant to general manager of the entire system.

The death of Mr. O'Herin resulted from an accident sustained while engaged directing the removal of the debris of a train wreck.





## A Clear Track

ahead, Railway men, when you protect your metal work with

# DIXON'S Silica Graphite PAINT

It has a world-wide reputation of over fifty years. Made in **FIRST QUALITY** only. Made for those who want **QUALITY, LONGER SERVICE** and **LOWEST COST** per year of service.

Because of the peculiar oily nature and flake formation of the pigment, Dixon's Paint has no equal in keeping moisture and gases away from the metal. Therefore metal properly painted with it resists corrosion longer than that painted with any other paint. That is the reason why leading railroads throughout the entire world use it as standard.

Write for booklet 69-B and long service records.

Made in **JERSEY CITY, N. J.**, by the

**Joseph Dixon Crucible Company**  
ESTABLISHED 1827

B-132

### Railroad Equipment Notes.

The Cambria & Indiana has ordered 1,000 hopper cars from the Cambria Steel Company.

The Union Pacific has ordered 1,500 box cars from the American Car & Foundry Company.

The Los Angeles & Salt Lake has ordered 200 automobile cars from the Pullman Company.

The Missouri, Kansas & Texas is in the market for 25 Mikado (2-8-2) and 10 Pacific (4-6-2) type locomotives.

The Chicago, Burlington & Quincy is in the market for 20 Mikado (2-8-2) type and 10 Santa Fe (2-10-2) type locomotives.

The Central Railroad of New Jersey has ordered 5 eight-wheel (0-8-0) locomotives from the American Locomotive Company.

The Delaware, Lackawanna & Western has ordered a Pacific (4-6-2) type locomotive from the American Locomotive Company.

The Diamond Gasoline Corporation has ordered 10 50-ton, 8,000 gal. capacity tank cars from the American Car & Foundry Company.

The Chesapeake & Ohio has given an order to the Western Steel Car & Foundry Company for the repair of 1,000 to 1,500 cars.

The Delaware & Hudson is reported in the market for 118 steel underframes for hopper cars, 25 for stock cars and 25 for refrigerator cars.

The Louisville & Nashville will begin construction soon of 8 Mikado (2-8-2) locomotives, following a previous lot of 8 now nearing completion.

The British Government has ordered 100 more light tank locomotives from the Baldwin Locomotive Works in addition to the 395 previously reported.

The Union Pacific is inquiring for 15 Santa Fe (2-10-2) type locomotives. It was reported previously in the market for 10 locomotives of the same type.

The Atchison, Topeka & Santa Fe has ordered 1,000 dumping stock cars from Haskell & Barker Car Company and 500 tank cars from the Pressed Steel Car Company.

The New York Central Lines have ordered 25 coaches from the Barney & Smith Car Company. These are in addition to orders placed with other builders for 175 cars.

The Philadelphia & Reading has ordered 1,000 hopper cars from the Cambria Steel Company, 500 from the Pressed Steel Car Company and 500 from the Standard Steel Car Company.

The El Paso & Southwestern has ordered 10 Pacific (4-6-2) type locomotives from the American Locomotive Company. Cylinders will be 27 by 28 ins., driving wheels 73 ins., and total weight in working order 315,000 lbs.

The Selby Safety Flag Company, St. Louis, Mo., is in receipt of orders from the Atlanta, Birmingham & Atlantic for improved flagmen's signal outfits for all crews. This is the ninth system to adopt this appliance as standard.

The Western Pacific has ordered 5 Mallet (2-6-6-2) type locomotives from the American Locomotive Company. Cylinders will be 23½ and 37 by 32 ins., driving wheels 57 ins. and total weight in working order 429,000 lbs.

A new wireless station has recently been erected at Viacha near La Paz. The West Coast Leader says that commercial service was established October 20 between the Bolivian station and the Lima wireless station at San Cristobal.

The Illinois Central has ordered 1,000 composite flat bottom gondola cars from the Pullman Company and 1,000 cars of the same type from the Haskell & Barker Car Company. The company contemplates buying 500 furniture cars.

The Louisville & Nashville has ordered 1000 50-ton gondola cars from the Mt. Vernon Car Manufacturing Company and will build 1000 additional cars in its own shops. These, with previously reported orders, make a total of 5000 cars.

Coates & Tweed have ordered four six-wheel switching locomotives from the American Locomotive Company. These locomotives will have 19 by 26-ins. cylinders, 50-in. driving wheels and a total weight in working order of 111,000 lbs.

The Baltimore & Ohio has ordered 480 box car bodies from the American Car & Foundry Company and is still in the market for 350 box car bodies. Contract for the repair of 500 cars has been awarded the Mt. Vernon Car Manufacturing Company.

### First Telegram.

Mr. Morse, inventor of the electric telegraph, experienced great difficulty in convincing the business men of the United States that his invention was practically hidden away in the archives of the Tennessee Historical Society at Nashville, Tenn., is the account of the first actual message ever sent over a telegraph line, says the *Youths Companion*.

According to the account preserved at Nashville, Hon. Robert L. Caruthers of Lebanon, Tenn., was a member of Congress in 1843, and a member of the committee to which was referred Mr. Morse's application for an appropriation to build a telegraph line from Washington to Baltimore. Most of the members of the committee looked upon Morse as a visionary, and his proposal as impracticable.

On the last day of the session Morse went to the committee room and told them that he had stretched a wire to the top of the capitol building and had a young man up there. If they would write a message he would send it up, and the young man would bring them a copy of it. None of them believed it could be done. Judge Caruthers, however, pulled the envelope of a letter out of his pocket and wrote a message. Mr. Morse, who had his instrument with him, sat down and sent the message. In a few minutes the young man walked into the room with an exact copy of the message. The committee reported favorably, and recommended the appropriation.

The bill passed just before the adjournment. Some one went to Mr. Morse's boarding house to inform him that the appropriation was made. The daughter of the landlady went to Mr. Morse's room, waked him and gave him the welcome news. He said to her, "My daughter, you shall send the first message that goes from Washington to Baltimore." That promise was fulfilled when she sent the famous message: "Whom hath God wrought!"

Judge Caruthers was an ardent Whig, and in 1843 the Whigs were very angry with President Tyler, whom they accused of betraying the party. The message that Judge Caruthers sent from the committee room to the young man at the top of the Capitol was, "Tyler deserves to be hanged."

### End of Steam Hose Coupler Litigation.

The Chicago Car Heating Company, Chicago, issued the following: "The long continued steam hose coupler patent litigation between the Chicago Car Heating Company and Gold Car Heating & Lighting Company has been ended by a decision by the United States Circuit Court of Appeals at Chicago in favor of the Chicago Car Heating Company. As there is no appeal, this decision ends the controversy."

### An Erie Railroad Banquet.

There was celebrated in the Hotel Martinique, New York, on November 22, the First Annual Banquet of the Underwood Social and Athletic Association Band. Except that band-garbed persons were strongly in evidence we should have considered it Erie Railroad men's dinner, Mr. F. D. Underwood, president of the Erie Railroad, being in the chair.

About 150 persons were present, a fair percentage of them being ladies. The banquet was odd in some respects. No intoxicating drink was provided, and there were no speeches or songs, the yelling band doing all the musical honors.

In some respects the banquet reminded us of a feast given to her agricultural tenants by Lady Kintore, a noble Scottish woman, on the occasion of her heir coming of age. Her ladyship was a strong teetotaler for people outside of her own class, and she debarred whiskey from her son's birthday feast, but provided champagne. Towards the end of the feast two hilarious farmers, each with three empty champagne bottles in front of him, were heard conversing about the liquid refreshments. One says to the other: "Man Blackiemuir, do you think we'er nae gaen to hae ony thing to drink the nicht?" "It's certainly time," said the other, "that French lemonade they've given us is verra cauld on the stomach."

### Cold Saws.

Catalogue No. 51, issued by the Newton Machine Tool Works, Twenty-third and Vine streets, Philadelphia, Pa., contains 51 pages of descriptive matter and illustrations in regard to cold metal sawing machines, with full particulars in regard to new developments, which mean for the user less operation, replacement and labor cost, greater output and economy in floor space, and, what is of considerable value, the introduction of air controlled clamps dispensing with even the necessity of muscular strength in the operator. There is also a portion of the catalogue devoted to prominent designs of other machines, embracing vertical and duplex milling machines, slotting and planing machines, key seat milling, portable drilling, cylinder boring and rod boring machines, all finely illustrated. Copies of the catalogue and estimates may be had on applying to the company's office at Philadelphia, Pa.

The Western Pacific has ordered five superheater Mallet type locomotives from the American Locomotive Company. These locomotives will have 23½ and 37 by 32-ins. cylinders, 57-in. driving wheels and a total weight in working order of 429,000 lbs. The equipment of this road is being rapidly improved, and the indications are that it will soon take its place among the thoroughly equipped roads in the West.

# GOLD Car Heating & Lighting Company

Manufacturers of

ELECTRIC,  
STEAM AND  
HOT WATER  
HEATING  
APPARATUS  
FOR RAILWAY CARS  
VENTILATORS  
FOR PASSENGER  
AND REFRIGER-  
ATOR CARS  
ACETYLENE SYSTEM  
OF CAR LIGHTING

Send for circular of our combination PRESSURE AND VAPOR SYSTEM OF CAR HEATING, which system automatically maintains about the same temperature in the car regardless of the outside weather conditions.

Main Office, Whitehall Building  
17 BATTERY PLACE  
NEW YORK

# Hydraulic

**Riveters Fixed and Portable  
Punches, Shears,  
Presses, Lifts, Cranes  
and Accumulators.**

**Matthews' Fire Hydrants,  
Eddy Valves  
Valve Indicator Posts.**

**The Camden High-Pressure Valves.**

**Cast Iron Pipe**

**R. D. Wood & Company**

**Engineers, Iron  
Founders, Machinists.**

**100 Chestnut St., Philadelphia, Pa.**

## Nichols Transfer Tables Turntable Tractors

**GEO. P. NICHOLS & BRO.  
1090 Old Colony Bldg. CHICAGO**

## For Testing and Washing Locomotive Boilers

USE THE

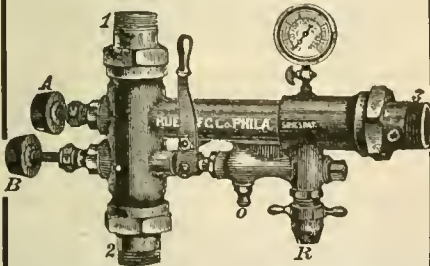

## Rue Boiler Washer and Tester

SEND FOR CATALOGUE

**Rue Manufacturing Co.  
228 Cherry Street Philadelphia, Pa.**

**Manufacturers of Injectors, Ejectors,  
Boiler Washers and Testers, Boiler Checks,  
Check Valves.**



## ASHTON POP VALVES AND GAGES

**The Quality Goods That Last**

**The Ashton Valve Co.  
271 Franklin Street, Boston, Mass.  
No. 174 Market St., Chicago, Ill.**

# Books, Bulletins, Catalogues, Etc.

**PASSENGER TERMINALS AND TRAINS.** By John A. Droege. Published by McGraw-Hill Book Company, New York. 410 pages, cloth. Price, \$5.00 net.

Mr. Droege, the general superintendent of the New York, New Haven & Hartford railroad, is already known as an able writer on railroad subjects. His previous work, "Freight Terminals and Trains," stamped the author at once as an authority on the subjects which his wide experience enabled him to master. The present work amply sustains his reputation. The book is divided into twenty-two chapters, and covers the entire field from the construction and maintenance details including interlocking and approaches with full descriptions of all kinds of stations with views and plans embodying typical and unique features, possessing educational value. The work is further illumined with descriptions of passenger trains and terminals of foreign countries. Systems of electrification are also presented, while the important subjects of baggage handling, ticket office, furniture, and the methods of successfully dealing with the public is particularly interesting and should be carefully studied by all who are engaged in handling that most complex of all machines, the average human being. The book is profusely illustrated, finely printed, substantially bound, carefully indexed, and altogether an excellent volume.

**LUBRICATING ENGINEER'S HANDBOOK.** By John Rome Battle. Published by J. B. Lippincott Company, Philadelphia. 333 pages, fully illustrated, cloth. Price, \$4.00, net.

The author of this book has had exceptional opportunities as a mechanical engineer in one of the largest manufacturing of lubricants in the world to collect data on this important subject, and he has taken pains to present the subject in a manner that not only engages the attention of the most casual reader, but satisfies the seeker after the most minute details. Every man interested in lubrication will obtain a vast amount of information in this book which extends to thirty-seven chapters, each taking up some new phase of the subject, and all in a high degree illuminating on a subject that is not known in any sense as it should be. Of particular interest to railway men is the chapter on the lubrication of railway locomotives and cars. The steam engine generally receives much attention from this eminent authority, and the chapter on Diesel engines shows that he has the matter in hand up to the present hour. The book is finely printed on toned paper. The illustrations are in the best style of the engraver's art, and the work as a whole may be considered the standard on the subject of which it treats.

**PROCEEDINGS OF THE TWENTY-THIRD CONVENTION OF THE AIR BRAKE CONVENTION.** 248 pages, flexible cloth. Price, \$2.00.

Year by year the proceedings of the Air Brake Association grow in interest, as the air brake itself has grown in the number and variety of its details, and the volume before us is the best proof of the fact that the members are keeping abreast of the work in which they are largely engaged. The last convention held at Atlanta, Ga., on May 2-5, was largely attended and the proceedings were unusually interesting, not only by reason of the able papers presented, but particularly by the discussions which the papers called forth. In common with similar associations, it seems as if the art of expression grew with the growth of the association, and the force and clearness with which the members taking part in the proceedings expressed themselves was remarkable, and is undoubtedly a fine reflex of the most advanced thoughts in relation to the air brake that could be presented in regard to the subjects under consideration. These embraced "Slack action in long passenger trains. Its relation to triple valves of different types and consequent results in the handling of passenger trains."—"Care of modern passenger brake equipment contributing to the minimum cost of maintenance and maximum efficiency."—"Proper piping of locomotives and cars, specifications and requirements for pipe in air brake work."—"Excess pressure."—"Hand brakes for heavy passenger cars."—"Need of efficient cleaning and repairing of freight brakes."—"Recommended Practice."—"Accumulation of moisture and its elimination from trains and yard testing plants." A prominent feature was a lecture on Thursday, May 4th, by Mr. Walter V. Turner on "The Universal Valve." This was cleverly illustrated by the use of moving pictures. It will thus be seen to what a large extent the air brake field was covered by the association, and although we presented a very full report of the proceedings in our June issue, the published volume presents a mass of interesting details beyond our space. We heartily commend the book to the attention of all interested in the details of the modern air brake.

### New Car Chart.

Mr. George L. Fowler, the eminent engineer, has produced an excellent drawing of the anatomy of a steel hopper bottom coal car, and the work has been reproduced and published by the Norman W. Henley Publishing Company, 132 Nassau street, New York. The drawing is

excellent, the complete details being clearly shown, with every part named and numbered, and in addition to the car, the truck, axle, hopper and journal box are shown in detail separately. The drawings are printed on strong, durable paper, and the work may be relied upon as absolutely correct. The chart measures 24x18 inches. Price, 25 cents.

#### Electric Railway Problems.

The University of Illinois Experiment Station, Urbana, Ill., has published Bulletin No. 20 presenting in a pamphlet of 36 pages some graphical solutions of electric railway problems. As is well known, the relation between speed and tractive effort is so involved that any attempt to obtain an exact formula has led to assumptions which cannot be made without seriously affecting the accuracy of the final result. The graphical methods, as compared with the analytical, form at once an accurate and easy means applicable to any condition in practice, and Professor A. M. Buck has clearly demonstrated the usefulness of the solutions presented in the bulletin. Copies may be had from the university. Price, 20 cents.

#### Hydraulic Valves and Fittings.

Catalogue No. 94, issued by the Watson-Stillman Company, New York, is among the best and most complete ever published by the enterprising company. It contains 96 pages substantially bound, and several hundreds of fine illustrations. As is well known the firm has been engaged in the manufacture of hydraulic machinery for nearly seventy years. Perfection in detail has come to their engineers through experience, and the merits of their operating valves, packings, regulating, release and safety valves, with all kinds of special valves and valve tools, are in design and quality of material as near the ideal as can be approached. The possibility of leakage in the valves has been eliminated long ago. Special combinations is a fine feature in their work, particularly in valves for controlling press, accumulators, and other high pressure mechanism. Any of the company's catalogues may be had on application to the company's New York office at 50 Church Street.

#### "National" Pipe.

The overshadowing supremacy of "National" Pipe was unquestionably established by the acid test of experience but the decision of the superior jury of awards at the Panama-Pacific Exposition at San Francisco placed it beyond question. Only one grand prize was awarded in each class and the National Tube Company, Frick Building, Pittsburgh, Pa., was awarded the grand prize on the superior merits of the company's tubular products

and fittings embracing "National" oil well casing, tubing drill pipe, drive pipe, rotary drill pipe and tubing with upset ends, line pipe, lead joint pipe, steel poles, standard pipe, black and galvanized, spellerized, 4 ins., and under; to minimize corrosion. "National" spellerized boiler tubes, "National" protective crating, "Kewanee" unions, valves and fittings. "Shelby" seamless steel tubing, special alloy tubing, boiler tubes, cylinders, flasks, steam pipe, drill pipe, mechanical tubing and trolley poles. The supremacy in this list of manufactures has not come in a day. It is the result of engineering science coupled to a patience that never wearies, a rigid system of tests, endless experiments and a determination to reach the ideal. The National Tube Company has secured success because it is deserved. The latest bulletin published by the company records the triumph. Send for a copy to the company's office at Pittsburgh, Pa.

#### Staybolts.

Requests continuing to come to the Flannery Bolt Company, Pittsburgh, Pa., for copies of the Exposition number of the company's catalogue, it was concluded to revise and embody the same in the last month's digest embodying a complete number of illustrations of the several parts of the Tate flexible staybolt, tools, etc., sufficient to make a handy book of reference and a condensed catalogue. All explanatory matter of a technical kind has been omitted, simply giving information as to dimensions and styles of the several parts. Of special merit is a refacing tool for scraping off sleeve seat for cap bearing, also tap for cleaning out the cap threads of the sleeves. Copies of the catalogue and information will be sent on request to the company's main office, Vanadium Building, Pittsburgh, Pa.

#### Keeping Cars in Service.

The American Steel Foundries, McCormick Building, Chicago, Ill., have issued an illustrated pamphlet on keeping cars in service, the chief feature of which is the economical and efficient method of strengthening wooden underframe cars so that they are fit for service in heavy trains by the application of Economy cast steel draft arms which replace the wooden draft timbers and strengthen the center sills against buffing and pulling shocks. They extend from the end of the car to a point thirty inches or more back of the body bolster. They are easily applied. Repeated experiments have shown that the wooden cars thus reinforced withstand service shocks fully as well as the all-steel underframe construction and the expense is much lower. All that is necessary is to submit data in regard to the old cars, and designs and estimates will be furnished, and the change completed in a fraction of the time that it takes to furnish new cars.

**STEEL STAMPS**  
INSPECTORS HAMMERS  
Hand Cut STEEL LETTERS & FIGURES  
LATHE TOOLS, TIME CHECKS,  
Noble & Westbrook Mfg. Co.  
9 ASYLUM ST. HARTFORD, CONN.

### Locomotive Engine Running and Management

By ANGUS SINCLAIR

This popular book has been a **RELIABLE REFERENCE** and comfortable **unfailing POCKET EDITION.**

PRICE, \$2.00

**ANGUS SINCLAIR CO.**

114 Liberty St.,

New York

### Locomotive Electric Headlights

of all descriptions

**RYLE-NATIONAL COMPANY**

**TURBO GENERATOR SETS**

900 SOUTH MICHIGAN AVENUE

CHICAGO, ILL.

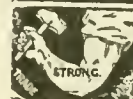

### The Armstrong Automatic Drift Drill

IS DRIFT AND HAMMER COMBINED.

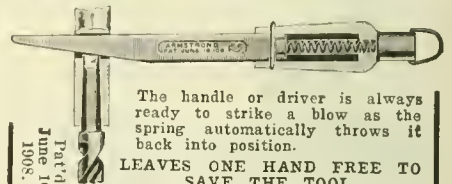

The handle or driver is always ready to strike a blow as the spring automatically throws it back into position.

LEAVES ONE HAND FREE TO SAVE THE TOOL.

Special Circular Mailed on Request.

**ARMSTRONG BROS. TOOL COMPANY**  
312 N. Francisco Ave., CHICAGO, U. S. A.

ENAMELED IRON FLUSH OR DRY CLOSETS  
**DUNER CAR CLOSETS**  
DUNER CO.  
118 E. CLINTON ST., CHICAGO

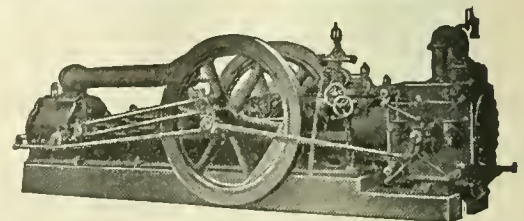

### The Norwalk Iron Works Co.

SOUTH NORWALK, CONN.

Makers of Air and Gas Compressors

For All Purposes

Send for Catalog













CARNEGIE LIBRARY OF PITTSBURGH



3 1812 04298 5615

