

TM 9-1005-211-12

DEPARTMENT OF THE ARMY TECHNICAL MANUAL

OPERATOR AND ORGANIZATIONAL
MAINTENANCE MANUAL
INCLUDING BASIC ISSUE
ITEMS LIST AND
REPAIR PARTS AND SPECIAL
TOOLS LIST

PISTOL, CALIBER .45, AUTOMATIC,
M1911A1, WITH HOLSTER, HIP (1005-673-
7965) AND PISTOL, CALIBER .45,
AUTOMATIC, M1911A1, WITH HOLSTER,
SHOULDER (1005-561-2003)

This reprint includes all changes in effect at the time of
publication; changes 1 through 5.

HEADQUARTERS, DEPARTMENT OF THE ARMY

SEPTEMBER 1968

WARNING

Care must be exercised to either have the pistol raised or pointed down range when loading.

Before firing, the firer must be sure that the bore of the pistol is free from any foreign matter. Firing a pistol with any obstruction in the bore will result in damage to the weapon and possible injury to personnel.

Before starting an inspection, be sure to clear the weapon. Do not actuate the trigger until the weapon has been cleared. Remove magazine, inspect the chamber to insure that it is empty and check to see that no ammunition is in position to be introduced.

Avoid skin contact with P-C-111. The compound should be washed off thoroughly with running water if it comes in contact with the skin. A good lanolin base cream, after exposure to the compound, is helpful. The use of rubber gloves and protective equipment is recommended.

Clear the weapon of all ammunition before starting an inspection. Remove the magazine and check the chamber to insure it is empty. Do NOT actuate the trigger until the weapon has been cleared.

CHANGE

No. 1



HEADQUARTERS
DEPARTMENT OF THE ARMY
WASHINGTON, D. C., 24 June 1969

**Operator and Organizational Maintenance Manual
Including Basic Issue Items List and
Repair Parts and Special Tools List**

**PISTOL, CALIBER .45, AUTOMATIC, M1911A1,
WITH HOLSTER, HIP (1005-673-7965)
AND PISTOL, CALIBER 45, AUTOMATIC, M1911A1,
WITH HOLSTER, SHOULDER (1005-561-2003)**

TM 9-1005-211-12, 16 September 1968, is changed as follows:

Page 3-6. Figure 3-7, is superseded as follows:

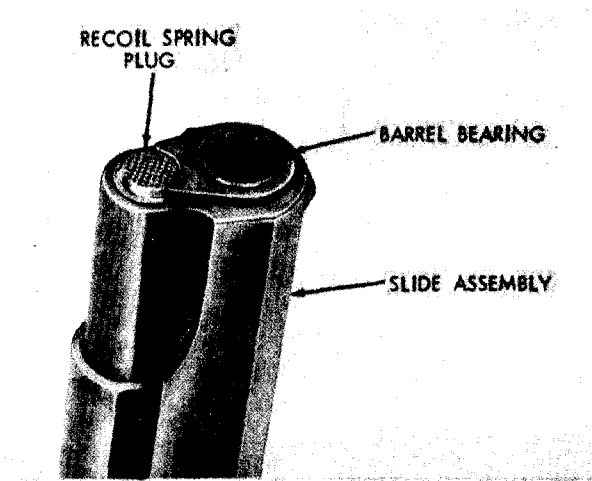

VIEWING MUZZLE END OF PISTOL.

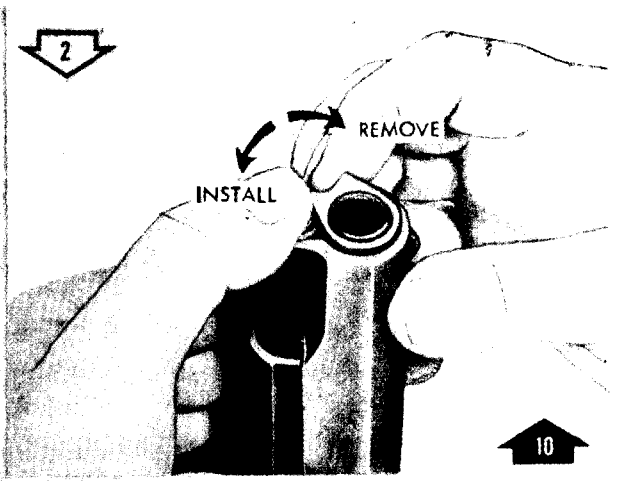

COMPRESS RECOIL SPRING PLUG AND ROTATE BARREL BEARING.

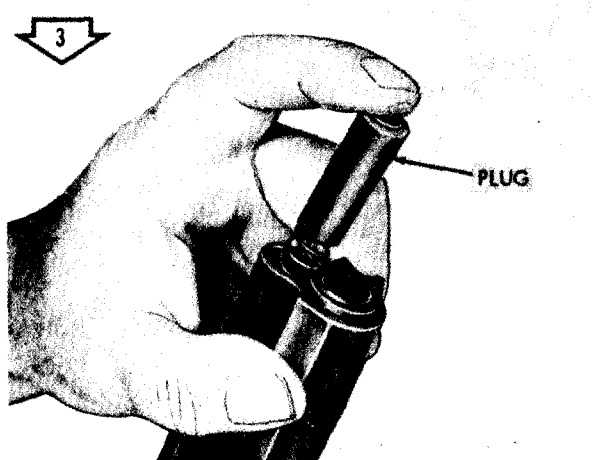

REMOVE/INSTALL RECOIL SPRING PLUG AND SPRING.

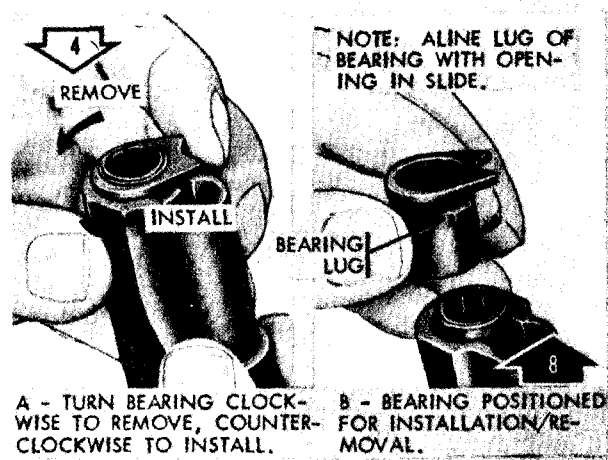
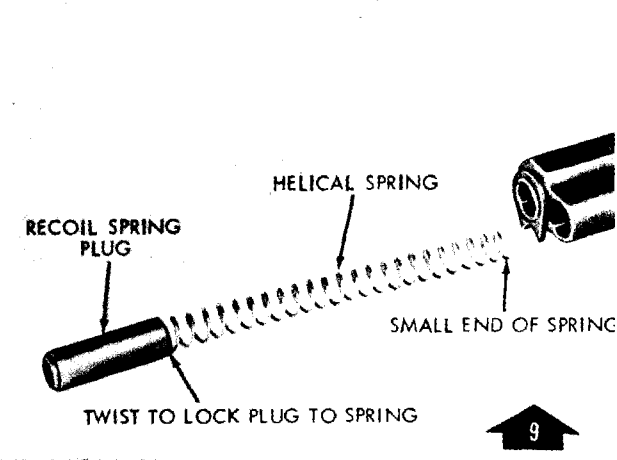

REMOVE/INSTALL BARREL BEARING.

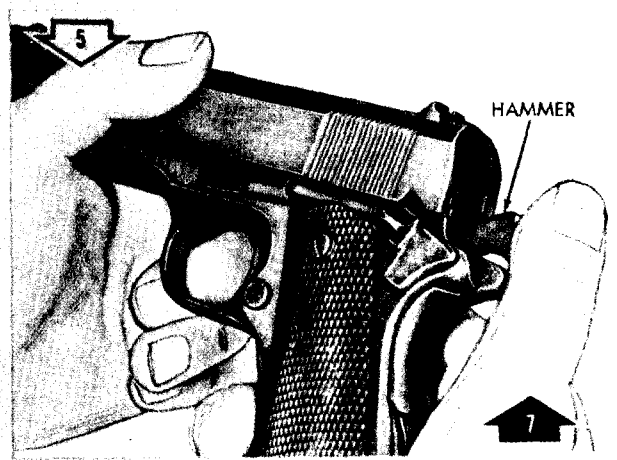

COCK HAMMER FOR REMOVING/INSTALLING SLIDE GROUP.

WE 17139A

Figure 3-7 Operator's disassembly/assembly of Caliber .45 Automatic Pistol, M1911A1. (2 of 3)

Table 3-5 - Inspection and Repair Procedures

Component Part or Assembly	Inspection	Repair	Reference
<p>Page 3-15. Pistol</p> <p>Slide Group</p> <p>* * * *</p>	<p>Overall condition: (Added) The ejector will be examined for burs and cracking. Looseness is of no concern as long as the ejector retaining pin is not miming or the ejector will not lift out of the receiver after removal of the slide.</p> <p>Nicks, scratches, and burs. * * * * *</p> <p>(Superseded) Recoil spring must have a free overall length of not less than 6 inches or more than 6 7/8 inches. The pistol will not be considered unserviceable due to the absence of the detent on the recoil spring plug as long as the pistol is otherwise serviceable.</p> <p>Note. (Added) Care must be exercised to preclude forceful ejection of the recoil spring and/or plug as the barrel bushing is turned during disassembly. Spring will not exhibit weakness, distortion or kinks. There will be no flat surfaces on the coil contour. Uniform diameter of all coils is permissible. A "flat" appearance on either end of the half-coil is not required.</p> <p>* * * * *</p>	<p>* *</p>	<p>* *</p>

By Order of the Secretary of the Army:

W. C. WESTMORELAND,
General, United States Army,
Chief of Staff.

Official:

KENNETH G. WICKHAM,
Major General, United States Army,
The Adjutant General.

Distribution:

To be distributed in accordance with DA Form 1240 (qty rqr Block #116), Organizational maintenance requirements for Pistol, Cal. .45, Automatic M1911A1.

CHANGE }
No. 2 }

HEADQUARTERS
DEPARTMENT OF THE ARMY
WASHINGTON, D. C., 29 September 1970

**Operator and Organizational
Maintenance Manual
Including Basic Issue
Items List and
Repair Parts and
Special Tools List**

**PISTOL, CALIBER .45, AUTOMATIC, M1911A1,
WITH HOLSTER, HIP (1005-673-7965)
AND PISTOL, CALIBER .45, AUTOMATIC, M1911A1,
WITH HOLSTER, SHOULDER (1005-561-2003)**

TM 9-1005-211-12, 16 September 1968, is changed as follows:

Page 3-2, table 3-2, procedure column, Disconnector Test, line 2. Change 1 1/4 inch to read 1/4 inch.

Page 3-8. Paragraph 3-10a is superseded as follows :

3-10. Cleaning, Inspection and Repair

a. Cleaning.

(1) **General.** Disassemble the pistol and clean all parts with a rag saturated with rifle bore cleaner (RBC) Dry parts, apply a light coat of general purpose lubricating oil (PL special) and assemble the pistol.

(2) *Cleaning after firing.* The pistol must be thoroughly cleaned as soon as possible, after firing, in the following manner.

(a) Disassemble the pistol.

(b) Clean all parts with rifle bore cleaner (RBC), dry all parts and apply a light coat of oil (PL special).

(c) Clean the bore and chamber as follows:

1. Wet a swab with rifle bore cleaner (RBC) and run it back and forth through the bore several times.

2. Attach the pistol bore brush (1, fig B-2) to the cleaning rod (2, fig. B-2).

3. Run dry swabs through the bore and chamber until they are clean.

4. Inspect the bore for cleanliness. If it is not free of all residue, repeat the cleaning process.

5. When the chamber and bore are clean, coat them lightly with oil (PL special).

6. Assemble the pistol.

7. Perform the test for correct assembly (para 3-9b).

8. Apply a light coat of oil to the exterior surfaces of the pistol.

Page 3-15, table 3-5. Make the following additions and changes:

Table 3-5. Inspection and Repair Procedures

Component part or assembly	Inspection	Repair	Reference
Slide Group	<p>(Added) Inspect for weak extractor.</p> <p><i>Note.</i> A weak extractor can readily be detected without disassembly of the slide group as follows:</p> <ol style="list-style-type: none"> 1. With the tip of the forefinger check for movement of the extractor within the slide, at the ejection part. 2. If the extractor exhibits a side to side movement, the spring tension of the extractor body is weak and the extractor should be replaced. 	<p>(Added)</p> <p>Replace weak extractor</p>	
Holster	<p><i>Note.</i> (Superseded) Brass portions and surrounding leather will be free of a green or bluish deposit. bather will be black, If leather is not black evacuate to direct support maintenance.</p>		

Page 4-1. Paragraph 4-2b is superseded as follows:

b. Cartridge, caliber .45, Blank, M9 is used to simulate fire and for salutes. Due to the

configuration of this cartridge it cannot be fired semi-automatically in the pistol and must be used for single shot only. It can be identified by the tapered mouth and absence of a bullet.

By Order of the Secretary of the Army:

W. C. WESTMORELAND,
General, United States Army,
Chief of Staff.

Official:

KENNETH G. WICKHAM,
Major General, United States Army,
The Adjutant General.

Distribution:

To be distributed in accordance with DA Form 12-40, (qty rqr block no. 116) Organizational maintenance requirements for Pistol, Cal. .45 Automatic M1911A1.

Change }
No. 3 }

HEADQUARTERS
DEPARTMENT OF THE ARMY
Washington, D.C. 6 October 1971

**Operator and Organizational
Maintenance Manual
Including Basic Issue Items List
AND
REPAIR PARTS AND SPECIAL TOOLS LIST
PISTOL, CALIBER .45, AUTOMATIC M1911A1
WITH HOLSTER, HIP (1005-673-7965)
AND PISTOL, CALIBER .45, AUTOMATIC M1911A1
WITH HOLSTER, SHOULDER (1005-561-2003)**

TM 9-1005-211-12, 16 September 1968, is changed as follows:

Page 3-15, table 3-5, Inspection column, opposite Pistol,

Added by Change 1 and is now rescinded.

(Rescinded) The ejector will be examined for burs and cracking. Looseness is of no concern as long as the ejector retaining pin is not missing or the ejector will not lift out of the receiver after removal of the slide.

By the Order of the Secretary of the Army:

Official:

VERNE L. BOWERS,
*Major General, United States Army,
The Adjutant General.*

W. C. WESTMORELAND,
*General, United States Army,
Chief of Staff.*

Distribution:

To be distributed in accordance with DA Form 12-40, (qty rqr block No. 116) Organizational maintenance requirements for Pistol, Cal. 45, Automatic M1911A1.

CHANGE }
No. 4 }

HEADQUARTERS
DEPARTMENT OF THE ARMY
WASHINGTON DC, 28 November 1972

**Operator and Organizational Maintenance Manual
Including Basic Issue Items List and Repair Parts and Special Tools List
PISTOL, CALIBER .45, AUTOMATIC, M1911A1, WITH HOLSTER HIP (1005-673-7965)
AND PISTOL, CALIBER .45, AUTOMATIC, M1911A1, WITH HOLSTER, SHOULDER
(1005-561-2003)**

Table 3-1. Expendible and Consumable Supplies

TM 9-1005-211-12, 16 September 1968, is changed as follows:

Page 1-1. Paragraph *b* is changed as follows:

b. Reporting of Errors. The reporting of errors, omissions, and recommendations for improving this publication by the individual user is encouraged. Reports should be submitted on DA Form 2028, (Recommended Changes to Publications), and forwarded direct to the Commander, US Army Weapons Command, ATTN: AMSWE-MAS-SP, Rock Island, 1161201.

Paragraph 1-3. After last sentence, add: "One cartridge magazine (1, fig B-1) is furnished with each weapon as a component item."

Page 3-1. Table 3-1 is superseded as follows:

FSN	Description	Symbol
6850-965-2332	CARBON REMOVING COM- POUND: 5 gal pail P-C-111 (81348)	
	CLEANING COMPOUND, RIFLE BOTTLE: MIL-C-372 (81349)	RBC
6850-224-6656	2 oz bottle	
6850-224-6657	8 oz can	
6850-281-1985	DRY CLEANING SOLVENT: 1 gal can P- D-680 (81348)	SD
9150-273-2389	LUBRICATING OIL, GENERAL PURPOSE: 4 oz. can VV-L-800 (81348)	PL-S
9150-292-9689	LUBRICATING OIL, WEAPONS: for below zero operations, 1 qt can MIL-L-14107 (81349)	LAW
7920-205-1711	RAG, WIPING: cotton (50 lb bale) DDD-R-30 Class 2, grade B (81348)	

Page B-1. Appendix B is changed as follows:
Change title to read:

**BASIC ISSUE ITEMS LIST
AND
ITEMS TROOP INSTALLED OR AUTHORIZED LIST
AND
ORGANIZATIONAL MAINTENANCE REPAIR PARTS
AND
SPECIAL TOOLS LIST**

Paragraph B-1 is changed to read:

B-1. Scope

This appendix lists basic issue items, items troop installed or authorized, repair parts and special tools required by the crew/operator for operation and required for the performance of organizational maintenance of the caliber .45 automatic pistol, M1911A1 with hip holster and shoulder holster.

Paragraph B-2 is changed as follows:

B-2. General

This basic issue items, items troop installed or authorized, repair parts and special tools list is divided into the following sections:

a. Basic Issue Items List-Section II. A list, in alphabetical sequence, of items absolutely essential for operation of the end item, which are furnished with and must be turned in with the end item.

b. Items Troop Installed or Authorized List-Section III. A list, in alphabetical sequence, of items required by the operator for sustained operation of the end item. These discretionary items will be requisitioned by the unit in accordance with its mission requirements. They may accompany the end item, but are not subject to be turned in with it.

Delete paragraph B-2c. Change paragraph B-2d to B-2c, B-2e to B-2d, and B-2f to B-2e,

Paragraph B-3d is changed as follows:

d. Unit of Measure (U/M). Indicates the standard or basic quantity by which the listed item is used in performing the actual maintenance function. This measure is expressed by a two-character alphabetical abbreviation, e.g., ea, in, pr, etc, and is the basis used to indicate quantities. When the unit of measure differs from the unit of issue, the lowest unit of issue that will satisfy the required units of measure will be requisitioned.

Page B-2. Paragraphs e, *f* and *g* are changed as follows:

e. Quantity Furnished with Equipment (Basic Issue Items Only). Indicates the quantity of the item furnished with the equipment.

f. Quantity Authorized (Items Troop Installed or Authorized Only). Indicates the quantity of the item authorized to be used with the equipment.

g. Quantity Incorporated in Unit. Indicates the quantity of the item used in that functional group/assembly. A "V" appearing in this column in lieu of a quantity indicates that no specific quantity is applicable, e.g., shims, spacers, etc.

Delete paragraphs *h*, *i* and *j*. Change paragraph *k* to *l*, and *l* to *i*.

Paragraph *k*(4). Change address to: Commander, US Army Weapons Command, ATTN: AMSWE-MAS-SP, Rock Island, IL 61201.

Page B-4. Section II is superseded as follows:

Section II. BASIC ISSUE ITEMS LIST

(1) Federal Stock No.	(2) Description Reference Number & Mfr. Code	(3) Unit of Meas	(4) Qty furn with equip	(5) Illustration	
				(a) Fig No	(b) tern No.
1095-592-6491	HOLSTER, PISTOL: HIP, M1916 (BLACK) 7791466 (19205)	A	EA	1	B-2 3
1095-973-2353	HOLSTER, PISTOL: SHOULDER M7 (BLACK) 7791527 (19205)	A	EA	1	B-2 4

Page B-5. Section 111 is superseded as follows:

Section III. ITEMS TROOP INSTALLED OR AUTHORIZED LIST

(1) Federal stock No.	(2) Description Reference Number & Mfr. Code	(3) Unit of Meas	(4) Qty auth
1005-550-4036	BRUSH, CLEANING, SMALL ARMS: M5 BORE 5504036 (192Q5)	EA	1
1005-550-8694	MAGAZINE, CARTRIDGE: 5508694 (19205)	EA	1
1005-556-4102	ROD, CLEANING, SMALL ARMS: M4 5564102 (19204)	EA	1

Page B-6. Delete section IV.

Page B-7. Add the following item after B-1, 9:

Section V. REPAIR PARTS LIST

Act on Code	(1) Source maint and Recov code			(2) Federal stock No.	(3) Description	(4) Unit of meas	(5) Qty inc in unit	(6) 15 Day Organiza- tional Maintenance Alw				(7) Illustration	
	(a) Source	(b) Maint	(c) Recov					Reference Number & Mfr. Code	Usable on Code	(a) 1-5	(b) 6-20	(c) 21-50	(d) 51-100
		PO		1005-501-3205	STOP, FIRING PIN: 5013205 (19205)	EA	1	*	*	*	*	B-1	10

By Order of the Secretary of the Army:

CREIGHTON W. ABRAMS
General, United States Army
Chief of Staff

Official:

VERNE L. BOWERS,
Major General, United States Army,
The Adjutant General.

Distribution:

To be distributed in accordance with DA Form 12-40. (qty rqr block No. 116) Organizational maintenance requirements for Pistol, Calbert .45, Automatic M1911A1.

Changes in force: C1, C2, C3, C4, and C5

TM 9-1005-211-12

CHANGE 5

CHANGE)
)
NO. 5)

HEADQUARTERS
DEPARTMENT OF THE ARMY
WASHINGTON, DC, 25 February 1976

Operator and Organizational Maintenance Manual
Including Basic Issue Items List and Repair Parts
and Special Tools List:

**PISTOL, CAL .45, AUTOMATIC: M1911A1, WITH HOLSTER, HIP
(1005-00-673-7965)**

**PISTOL, CAL .45, AUTOMATIC: M1911A1, WITH HOLSTER,
SHOULDER (1005-00-561-2003)**

Current as of 3 December 1975

TM 9-1005-211-12, 16 September 1968 is changed as follows:

Title is changed as shown above.

Appendix B is superseded as follows:

APPENDIX B

BASIC ISSUE ITEMS LIST, ITEMS TROOP INSTALLED OR AUTHORIZED LIST, AND ORGANIZATIONAL MAINTENANCE REPAIR PARTS AND SPECIAL TOOLS LIST

SECTION I. INTRODUCTION

B-1. Scope

This appendix lists repair parts and special tools for performance of organizational maintenance of the caliber .45 automatic pistol M1911A1 with hip holster and caliber .45, automatic pistol, M1911A1 with shoulder holster.

B-2. General

This repair parts and special tools list is divided into the following sections:

a. Basic Issue Items List (BIIL). Not applicable.

b. Items Troop Installed or Authorized List (ITIAL). Not applicable.

c. Section II. Repair Parts List. A list of repair parts authorized for use in the performance of maintenance. The list also includes parts which must be removed for replacement of the authorized parts. Parts lists are composed of functional groups in ascending numerical sequence, with the parts in each group listed in figure and item number sequence.

d. Section III. Special Tools List. A list of special tools and support equipment authorized for the performance of maintenance.

e. Section IV. National Stock Number (NSN) and Part Number Index. A list, in ascending numerical sequence of the National Item Identification Number (NIIN) the last nine figures of the of all National stock numbers appearing in the listings, followed by a list, in alphameric sequence, of all part numbers appearing in the listings. National stock numbers and part numbers are cross-referenced to each illustration figure and item number appearance. This index is followed by a cross-reference list of reference designations to figure and item numbers when applicable.

B-3. Explanation of Columns

The following provides an explanation of columns found in the tabular listings:

a. Illustration. This column is divided as follows:

(1) *Figure number.* Indicates the figure number of the illustration in which the item is shown.

(2) *Item number.* The number used to identify each item called out in the illustration.

b. Source, Maintenance, and Recoverability Codes (SMR).

(1) *Source code.* Source codes are assigned to support items to indicate the manner of acquiring support items for maintenance, repair, or overhaul of end items. Source codes are entered in the first and second positions of the Uniform SMR Code format as follows:

Code	Definition
PA	Item procured and stocked for anticipated or known usage.
PB	Item procured and stocked for insurance purposes because essentiality dictates that a minimum quantity be available in the supply system.
PC	Item procured and stocked and which otherwise would be coded PA except that it is deteriorative in nature.
PD	Support item, excluding support equipment, procured for initial issue or outfitting and stocked only for subsequent or additional initial issues or outfittings. Not subject to automatic replenishment.
PE	Support equipment procured and stocked for initial issue or outfitting to specified maintenance repair activities.
PF	Support equipment which will not be stocked but which will be centrally procured on demand.

Code	Definition
PG	Item procured and stocked to provide for sustained support for the life of the equipment. It is applied to an item peculiar to the equipment which, because of probable discontinuance or shutdown of production facilities, would prove uneconomical to reproduce at a later time.
KD	An Item of a depot overhaul/repair kit and not purchased separately. Depot kit defined as a kit that provides items required at the time of overhaul or repair.
KF	An item of a maintenance kit and not purchased separately. Maintenance kit defined as a kit that provides an item that can be replaced at organizational or intermediate levels of maintenance.
KB	Item included in both a depot overhaul/repair kit and a maintenance kit.
MO	Item to be manufactured or fabricated at organizational level.
MF	Item to be manufactured or fabricated at the direct support maintenance level.
MH	Item to be manufactured or fabricated at the general support maintenance level.

Code	Definition
MD	Item to be manufactured or fabricated at the depot maintenance level.
AO	Item to be assembled at organizational level.
AF	Item to be assembled at direct support maintenance level.
AH	Item to be assembled at general support maintenance level.
AD	Item to be assembled at depot maintenance level.
XA	Item is not procured or stocked because the requirements for the item will result in the replacement of the next higher assembly.
XB	Item is not procured or stocked. If not available through salvage, requisition.
XD	A support item that is not stocked. When required, item will be procured through normal supply channels.

NOTE

Cannibalization or salvage may be used as a source of supply for any item source coded above, except those coded XA, XD, and aircraft support items as restricted by AR 700-42.

(2) Maintenance code. Maintenance codes are assigned to indicate the levels of maintenance authorized to USE and REPAIR support items. The maintenance codes are

entered in the third and fourth positions of the Uniform SMR Code format as follows:

(a) The maintenance code entered in the third position will indicate the lowest maintenance level authorized to remove, replace, and use the support item. The maintenance code entered in the third position will indicate one of the following levels of maintenance :

Code	Application/ explanation
C	Crew or operator maintenance performed within organizational maintenance.
O	Support item is removed, replaced, used at the organizational level.
I	Support item is removed, replaced, used by the direct support element of integrated direct support maintenance.
F	Support item is removed, replaced, used at the direct support level.
H	Support item is removed, replaced, used at the general support level.
D	Support items that are removed, replaced, used at depot, mobile depot, specialized repair activity only.

NOTE

Codes "I" and "F" will be considered the same by direct support units.

(b) The maintenance code entered in the fourth position indicates whether the item is to be repaired and identifies the lowest maintenance level with the capability to perform complete repair (i.e., all authorized maintenance functions). This position will contain one of the following maintenance codes:

Code	Application/ explanation
O.....	The lowest maintenance level capable of complete repair of the support item is the organizational level.
F.....	The lowest maintenance level capable of complete repair of the support item is the direct support level.
H.....	The lowest maintenance level capable of complete repair of the support item is the general support level.
D.....	The lowest maintenance level capable of complete repair of the support item is the depot level, performed by (enter applicable activity) depot, mobile depot, or specialized repair activity.
L.....	Repair restricted to designated specialized repair activity.
Z.....	Nonreparable. No repair is authorized.

Code	Application/ explanation
B.....	No repair is authorized. The item may be reconditioned by adjusting, lubrication, etc, at the user level. No parts or special tools are procured for the maintenance of this item.

(3) **Recoverability code.** Recoverability codes are assigned to support items to indicate the disposition action on unserviceable items. The recoverability code is entered in the fifth position of the Uniform SMR Code format as follows:

Recoverability code	Definition
Z.....	Nonreparable item. When unserviceable, condemn and dispose at the level indicated in position 3.
O.....	Reparable item. When uneconomically repairable, condemn and dispose at organizational level.
F.....	Reparable item. When uneconomically repairable, condemn and dispose at the direct support level.
H.....	Reparable item. When uneconomically repairable, condemn and dispose at the general support level.
D.....	Reparable item. When beyond lower level repair capability, return to depot. Condemnation and disposal not authorized below depot level.

Recoverability

code Definition

L..... Repairable item. Repair, condemnation, and disposal not authorized below depot/specialized repair activity level.

A..... Item requires special handling or condemnation procedures because of specific reasons (i.e., precious metal content, high dollar value, critical material, or hazardous material). Refer to appropriate manuals/directives for specific instructions.

c. National Stock Number (NSN).

Indicates the National stock number assigned to the item and will be used for requisitioning purposes.

d. Part Number. Indicates the primary number used by the manufacturer (individual, company, firm, corporation, or Government activity), which controls the design and characteristics of the item by means of its engineering drawings, specifications, standards, and inspection requirements, to identify an item or range of items.

NOTE

When a stock numbered item is requisitioned, the repair part received may have a different part number than the part being replaced.

e. Federal Supply Code for Manufacturer (FSCM). The FSCM is a five-digit numeric code listed in SB 708-42 which is used to identify the manufacturer, distributor, or Government agency, etc.

f. Description. Indicates the Federal item name if required, a minimum description to identify the item. Items that are included in kits and sets are listed below the name of the kit or set with the quantity of each item in the kit or set indicated in the quantity incorporated in unit column. When the part to be used differs between serial numbers of the same model, the effective serial numbers are shown as the last line of the description. In the special tools list, the initial basis of issue (BOI) appears as the last line in the entry for each special tool, TMDE, and support equipment. When the density of the equipments supported exceeds density spread indicated in the basis of issue, the total authorization is increased accordingly.

g. Unit of Measure (U/M). Indicates the standard or the basic quantity of the listed item as used in performing the actual maintenance function. This measure is expressed by a two-character alphabetical abbreviation (e.g., ea, in., pr, etc). When the unit of measure differs from the unit of issue, the lowest unit of issue that will satisfy the required units of measure will be requisitioned.

h. Quantity Incorporated in Unit. Indicates the quantity of the item used in the breakout shown on the illustration figure, which is prepared for a functional group, subfunctional group, or an assembly. A "V" appearing in this column in lieu of a quantity indicates that no specific quantity is applicable (e.g., shims, spacers, etc).

B-4. Special Information

a. Not applicable.

b. Action change codes indicated in the left-hand margin of the listing page denote the following:

N Indicates an added item
 C Indicates a change in data
 R Indicates a change in NSN only

c. Usable on codes are shown in the description column. Uncoded items are applicable to all models. Identification of the usable on codes used in this publication are :

Code	Used on
163...	Pistol, cal .45, automatic: M119A1, w/holster w/e
612...	Pistol, cal .45, automatic: M119A1, w/shoulder holster w/e

B-5. How to Locate Repair Parts

a. *When National Stock Number or Part Number is Unknown:*

(1) *First.* Using the table of contents determine the functional group within which the repair part belongs. This is necessary since illustrations are prepared for functional groups and listings are divided into the same groups.

(2) *Second.* Find the illustration covering the functional group to which the repair part belongs.

(3) *Third.* Identify the repair part on the illustration and note the illustration figure and item number of the repair part.

(4) *Fourth.* Using the repair parts listing, find the figure and item number noted on the illustration.

b. *When National Stock Number or Part Number is Known:*

(1) *First.* Using the index of National stock numbers and part numbers, find the pertinent National stock number or part number. This index is in ascending NIIN sequence followed by a list of part numbers in ascending alphabetic sequence, cross-referenced to the illustration figure number and item number.

(2) *Second.* After finding the figure and item number, locate the figure and item number in the repair parts list.

B-6. Abbreviations

Abbreviation Explanation

al	aluminum
aly	alloy
blk	black
brs	brass
cd	cadmium
c to c	center to center
condct	conductor
cop	copper
crs	corrosion-resistant steel
fnsh	finish
matl	material
mtg	mounting
n	nylon
oxd	oxide
phos	phosphate
plstc	plastic
pld	plated
ptd	painted
shk	shank
stk	stock
stl	steel

SECTION II. REPAIR PARTS LIST

(1) ILLUSTRATION (a) FIG NO	(2) ITEM NO (b) SMR CODE	(3) FEDERAL STOCK NUMBER	(4) PART NUMBER	(5) FSCM	(6) DESCRIPTION USABLE ON CODE	(7) U/M	(8) QTY INC IN UNIT
					01 REPAIR PARTS FOR: PISTOL, CAL. 45, AUTOMATIC, MAJOR GROUPS AND ASSEMBLIES		
B1	1	PACZZ 1005-00-550-8694	5508694	19204	MAGAZINE, CARTRIDGE	EA	3
					0101 SLIDE GROUP		
B1	12	PAOZ 5360-00-501-3204	5013204	19204	SPRING, HELICAL, COMPRESSION 40 COILS FIRING PIN	EA	1
B1	10	PAOZZ 1005-00-501-3205	5013205	19204	STOP, FIRING PIN	EA	1
B1	9	PAOZZ 5315-00-501-3199	5013199	19204	PIN, STRAIGHT, HEADLESS S.O. 1555 MAX DIA. 0.358 O/A LG BARREL LINKS	EA	1
					GROUP 0102 RECEIVER GROUP		
B1	18	PAOZZ 5360-00-600-8602	6008602	19204	SPRING, SEAR	EA	1
B1	27	PAOZZ 1005-00-600-8600	6008600	19204	STRUT, HAMMER	EA	1
B1	26	PAOZZ 5305-00-601-9023	6019023	19204	SCREW, MACHINE FIL-HD, S, PHOS-CTD, 0.150-5 ONS, 0.260 O/A LG GRIP	EA	4
B1	27	PAOZ 1005-00-556-4063	5564063	19204	GRIP, PISTOL LH, PLASTIC, CHECKERED	EA	1
B1	28	PAOZZ 1005-00-556-4062	5564062	19204	GRIP, PISTOL RH, PLASTIC, CHECKERED	EA	1
B1	30	PACZZ 5360-00-501-3194	5013194	19204	SPRING, HELICAL, COMPRESSION 14-1/2 COILS, PLUNGER	EA	1

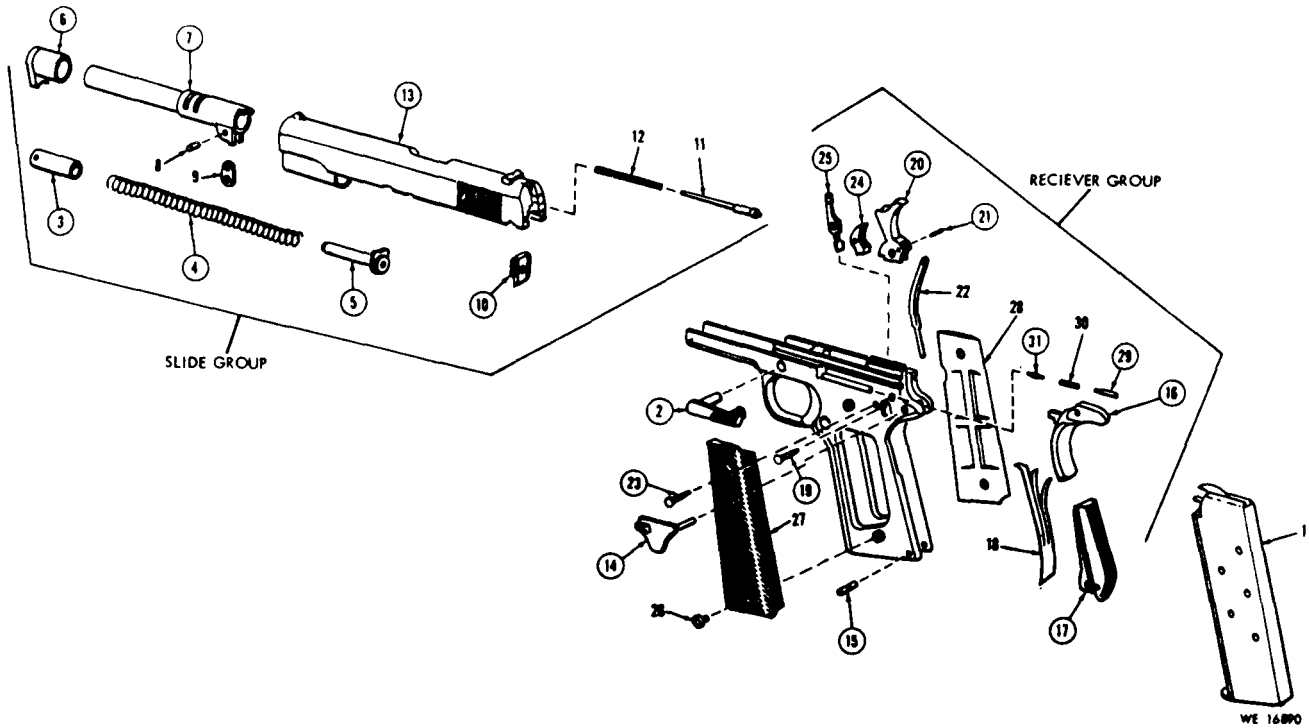

Figure B 1. Caliber .45, Automatic Pistol, M1911A1—partial exploded view.

SECTION III. SPECIAL TOOLS LIST

TM 9-1005-211-12

(1) ILLUSTRATION		(2)	(3)	(4)	(5)	(6)	(7)	(8)
(a) FIG NO.	(b) ITEM NO.	SMR CODE	FEDERAL STOCK NUMBER	PART NUMBER	FSCM	DESCRIPTION <i>USABLE ON CODE</i>	J/M	QTY INC IN UNIT
N		PA0ZZ	1005-00-288-3565	5019316	19204	GROUP 01 TOOLS AND EQUIPMENT SWAB, SMALL ARMS CLEANING COTTON, 2 1/2 SQ : 1000 IN PKG:	EA	1

SECTION IV. NATIONAL STOCK NUMBER AND PART NUMBER INDEX

National stock no.	Fig no.	Item no.	National Stock no.	Fig no.	Item no.
1005-00-288-3565			1005-00-556-4062	B1	28
5360-00-501-3194	B1	30	1005-00-556-4063	B1	27
5315-00-501-3199	B1	8	1005-00-600-8600	B1	22
5360-00-501-3204			5360-00-600-8602	B1	18
1005-00-501-3205			5305-00-601-9023	B1	26
1005-00-550-8694					

Part no.	FSCM	Fig no.	Item no.	Part no.	FSCM	Fig no.	Item no.
5013194	19204	B1	30	5564062	19204	B1	28
5013199	19204	B1	8	5564063	19204	B1	27
5013204	19204			6008600	19204	B1	22
5013205	19204			6008602	19204	B1	18
5019316	19204	C1	B0	6019023	19204	B1	26
5508694							

By Order of the Secretary of the Army:

FRED C. WEYAND
General, United States Army
Chief of Staff

Official:

PAUL T. SMITH
Major General, United States Army
The Adjutant General

DISTRIBUTION:

To be distributed in accordance with DA Form 12-40, (qty rqr block no.
116) Organizational maintenance requirements for Pistol, Cal .45, M1911A1.

Technical Manual }
 No. 9-1005-211-12 }

HEADQUARTERS,
 DEPARTMENT OF THE ARMY
 Washington, D. C., 16 September 1968

**OPERATOR AND ORGANIZATIONAL MAINTENANCE MANUAL
 INCLUDING BASIC ISSUE ITEMS LIST
 AND REPAIR PARTS AND SPECIAL TOOLS LIST**

**PISTOL, CALIBER .45, AUTOMATIC, M1911A1, WITH
 HOLSTER, HIP (1005-673-7965) AND PISTOL, CALIBER
 .45, AUTOMATIC, M1911A1, WITH HOLSTER,
 SHOULDER (1005-561-2003)**

This manual is current as of 6 February 1968.

	Paragraphs	Pages
CHAPTER 1. INTRODUCTION		
Section I. General	1-1, 1-2	1-1
II. Description and data	1-3, 1-4	1-1
CHAPTER 2. OPERATING INSTRUCTIONS		
Section I. Service upon receipt of materiel	2-1	2-1
II. Operation under usual conditions	2-2, 2-4	2-1, 2-2
III. Operation under unusual conditions	2-5, 2-7	2-2
CHAPTER 3. OPERATOR AND ORGANIZATIONAL MAINTENANCE INSTRUCTIONS		
Section I. Operators tools and equipment	3-1	3-1
II. Organizational maintenance repair parts	3-2	3-1
III. Lubrication instructions	3-3, 3-4	3-1
IV. Preventive maintenance checks and services	3-5, 3-6	3-1, 3-4
V. Troubleshooting	3-7, 3-8	3-4
VI. Operators maintenance procedures	3-9, 3-10	3-5, 3-8
VII. Organizational maintenance procedures	3-11, 3-12	3-8, 3-14
CHAPTER 4. AMMUNITION	4-1, 4-2	4-1
CHAPTER 5. DEMOLITION TO PREVENT ENEMY USE	5-1	5-1
APPENDIX A. REFERENCES		A-1
APPENDIX B. BASIC ISSUE ITEMS LIST AND ORGANIZATIONAL MAINTENANCE REPAIR PARTS AND SPECIAL TOOLS LIST		
Section I. Introduction		B-1
II. Basic issue items		B-4
III. Maintenance and operating supplies		B-5
IV. Prescribed load allowance		B-6
V. Repair parts (fig B-1)		B-7
VI. Tools and equipment (fig B-2)		B-8
APPENDIX C. MAINTENANCE ALLOCATION CHART.		C-1

*This manual supersedes TM 9-1005-211-12P/2, 29 April 1964

CHAPTER 1

INTRODUCTION

Section I. GENERAL

1-1. Scope

This manual contains instructions for the operator and organizational maintenance personnel of the Caliber .45 Automatic Pistol M1911A1 as allocated by the Maintenance Allocation Chart.

1-2. Forms and Records

a. General. DA Forms and procedures used for equipment maintenance will be only those

prescribed in TM 38-750, Army Equipment Record Procedures.

b. Recommendations for Equipment Publication Improvements. Report of errors, omissions, and recommendations for improving this publication by the individual user is encouraged. Reports should be submitted on DA Form 2028 (Recommended Changes to DA Publications) and forwarded direct to the Commanding General, U.S. Army Weapons Command, ATTN: AMSWE-SMM-P, Rock Island, Illinois 61201.

Section II. DESCRIPTION AND DATA

1-3. General

The Caliber .45 Automatic Pistol M1911A1 (figs 1-1 and 1-2) is a recoil operated hand weapon. It is fed from a seven round magazine and is a semiautomatic weapon, firing one

round each time the trigger is squeezed. The weapon can be carried in either a hip or shoulder holster. The pistol can be broken down into two major groups (fig. 1-3).

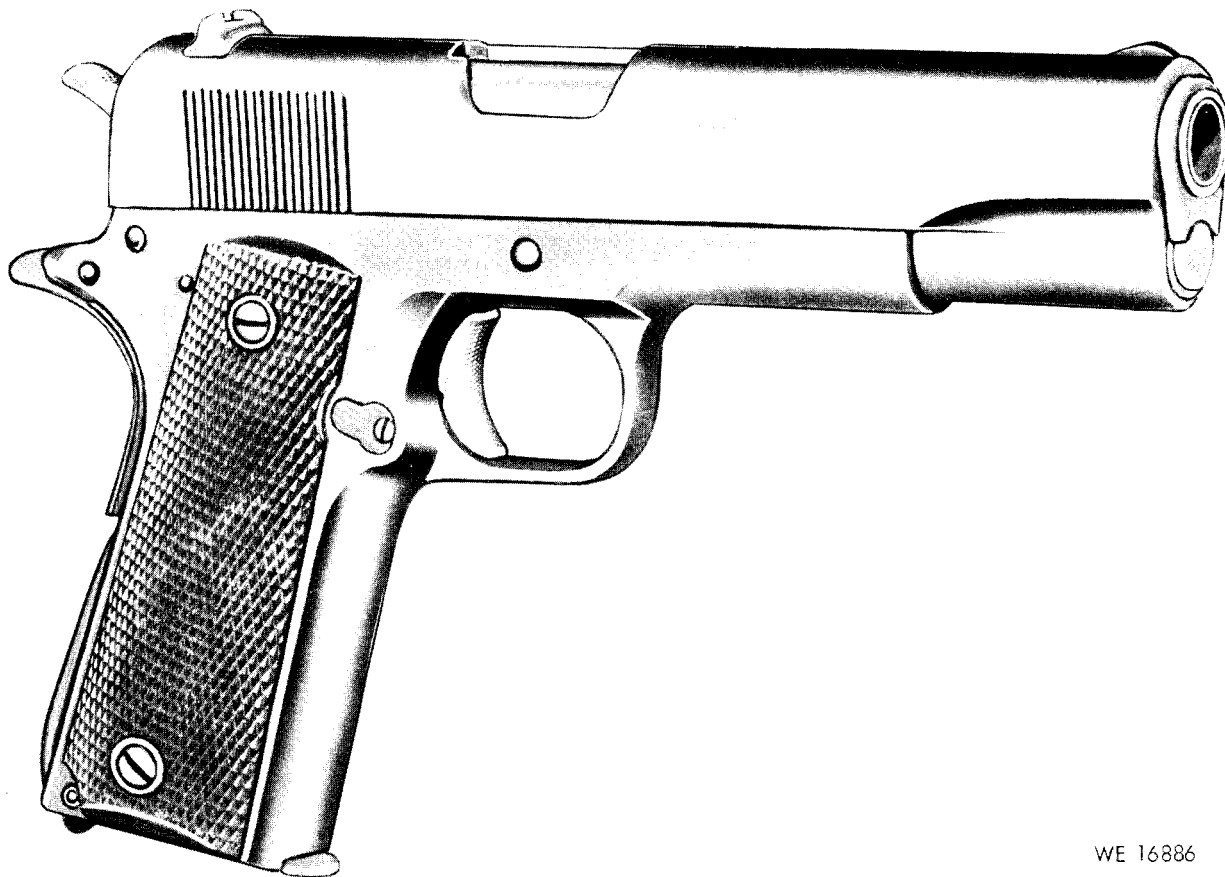

WE 16886

Figure 1-1. Caliber .45 Automatic Pistol, M1911A1 - right front view.

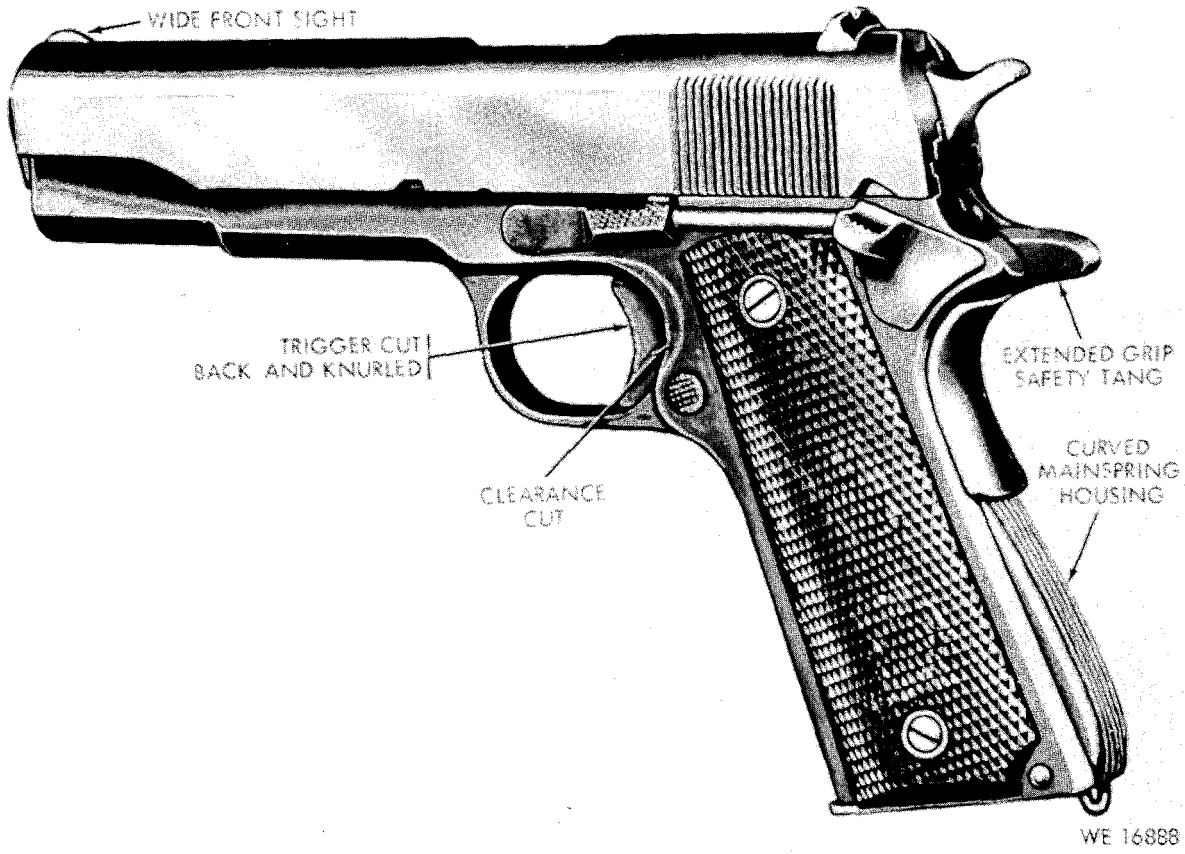

Figure 1-2. Caliber .45 Automatic Pistol, M1911A1 - left rear view.

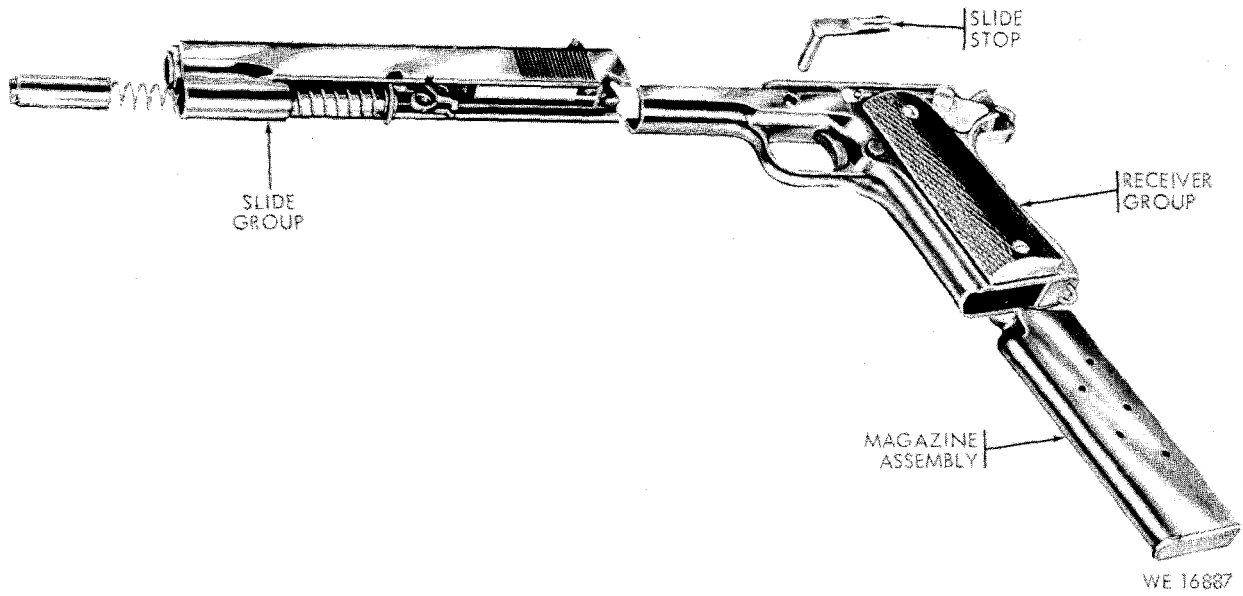

Figure 1-3. Caliber .45 Automatic Pistol, M1911A1 - major groups and assemblies.

1-4. Tabulated Data

Length	8-5/8 in.
Weight:	
Empty magazine	2.5 lb (approx)
Loaded magazine	3.0 lb (approx)
Height of front sight above axis of bore	0.5597 in.
Sight radius	6.481 in.
Muzzle velocity (max)	830 fps
Maximum range	1500 meters
Maximum effective range	50 meters
Trigger pull	5 to 6-1/2 lb
Diameter of bore (caliber)	0.45 in.
Number of lands and grooves	6
Rifling, left hand, one turn in.	16 in.
Length of barrel	5.03 in.
Length of rifling	4.118 in. (min)
Depth of grooves	0.003 in.
Cooling system	air

CHAPTER 2

OPERATING INSTRUCTIONS

Section I. SERVICE UPON RECEIPT OF MATERIEL

2-1. General

Refer to table 2-1.

Table 2-1. Service Upon Receipt of Materiel

Step	Action	Reference
1	Remove pistol and items from container.	
2	Remove VCI packaging.	
3	Check for missing items.	
<i>Note.</i> Items must agree with Basic Issue Items List.		App B

Step	Action	Reference
4	Field strip weapon and inspect for: Missing parts Proper assembly	Par. 3-9
5	Clean and lubricate (if necessary).	Par. 3-3, 3-4, and 3-10a
6	Assemble.	Par. 3-9
7	Hand function.	

Section II. OPERATION UNDER USUAL CONDITIONS

2-2. General

Care and cleaning of the pistol includes daily preventive maintenance, which is the ordinary care of the pistol required to preserve its condition and appearance when no firing is done. Before-firing cleaning insures that the pistol is safe to fire and is properly lubricated for efficient operation, and after-firing maintenance insures that all corrosion-inducing agents are completely removed. For cleaning procedures refer to paragraph 3-10a. For lubrication procedures refer to paragraphs 3-3 and 3-4. The operator must be thoroughly familiar with all safety features of the pistol. For safety tests, refer to table 3-2.

2-3. Loading, Firing, and Unloading

a. Loading.

Warning. Care must be exercised to either have the pistol raised or pointed down range when loading.

Warning. The firer must be sure that the bore of the pistol is free from any foreign matter. Firing a pistol with any obstruction in the bore will result in damage to the weapon and possible injury to personnel.

Draw pistol from holster, insert magazine, pull slide to the rear and release, putting a round in the chamber, press the safety lock (small arms safety) up into the SAFE position.

b. Firing.

To fire the pistol, press the safety lock (small arms safety) down to the FIRE position to prevent disturbing the firing grip of the right hand. Obtain the correct sight alignment and sight picture and squeeze the trigger. To fire successive shots, the trigger must be released and squeezed again. When the last cartridge from the magazine has been fired, the slide remains to the rear.

c. Unloading. To unload press the magazine catch and remove the magazine. If the slide is in the forward position, pull the slide to the rear and push the slide stop up. Inspect the chamber to insure that the pistol is clear. Press the slide stop down, allowing the slide to go forward. Pull trigger while weapon is in safe position.

2-4. Firing Malfunctions and Stoppages

a. Malfunctions. A malfunction is a failure of the weapon to function properly. Malfunctions are classified as defects in the weapon that normally do not cause a break in the cycle of operation.

b. Stoppages. A stoppage is an unintentional interruption in the cycle of operation. A stoppage occurs when the pistol does not fire through no fault of the firer.

c. Immediate Action in Case of Firing Malfunctions.

(1) Immediate action is the prompt action taken by the firer to reduce a stoppage. The procedure for applying immediate action should become instinctive to the operator of the pistol. If a stoppage occurs, immediate action is applied automatically in an effort to reduce the stoppage without attempting to discover the cause at that time.

(2) In the event the slide is fully forward, the hammer falls, and the pistol fails to fire, apply immediate action as follows:

(a) Manually cock the hammer without opening the chamber and make one additional attempt to fire. If the pistol still fails to fire, wait 10 seconds, and then raise the pistol. Grasp the slide with the thumb and first finger of the non-firing hand, keeping the thumb on the right side of the slide. Pull the slide rearward rapidly, to its full extent. Rotate the pistol to the right allowing the unfired round to drop out, release the slide and allow it to return to the forward position, cambering a new cartridge.

Caution. Keep the weapon pointed down range during this operation.

(b) Aim and attempt to fire.

(3) In the event the slide is not fully forward, remove the trigger finger from the trigger guard and with the non-firing hand attempt to push the slide fully forward. If the slide will not move forward, proceed as follows:

(a) Bring the weapon to a safe position.

(b) Remove the magazine.

(c) Grasp the slide with the left hand, pull the slide to the rear, and lock it with the slide stop.

(d) Inspect the chamber. Remove any obstructions.

(e) Insert another loaded magazine into the pistol

(f) Release the slide.

(g) Aim and attempt to fire.

(4) If the weapon does not fire after the application of immediate action as outlined above, a detailed inspection should be made to determine the cause of the stoppage.

Section III. OPERATION UNDER UNUSUAL CONDITIONS

2-5. General

In addition to the normal operation of the pistol, special care in cleaning and lubrication must be observed where extremes of temperature, humidity, and atmospheric conditions exist or are anticipated. Proper cleaning, lubrication, storage, and handling of lubricants not only insure operation of the weapon, but also guard against wear of the working parts and deterioration of the material.

2-6. Operation in Extreme Cold

a. In temperatures below freezing, it is necessary that the moving parts of the weapon be kept free from moisture. Excess oil on working parts will solidify and cause sluggish operation or complete failure.

b. Before cleaning, allow the weapon to at-

tain room temperature. Perform detailed disassembly (par 3-9) and complete cleaning (par 3-10a) before use in temperatures below 0°F. Working surfaces that show signs of wear may be lubricated by rubbing lightly with a rag that has been wet with weapons lubricating oil (LAW).

2-7. Operation in Extreme Heat

a. In tropical climates where temperature and humidity are high, or where salt air is present, and during rainy seasons the weapon should be disassembled, inspected, all parts wiped dry, and lightly oiled daily.

b. In hot, dry climates where sand and dust may get into the weapon, daily disassembly, inspection and cleaning should be accomplished. After cleaning, the pistol should be wiped dry and no lubricants applied.

CHAPTER 3

OPERATOR AND ORGANIZATIONAL MAINTENANCE INSTRUCTIONS

Section I. OPERATORS TOOLS AND EQUIPMENT

3-1. General

For operators tools and equipment, refer to appendix B.

Section II. ORGANIZATIONAL MAINTENANCE REPAIR PARTS

3-2. General

For the listing of organizational maintenance authorized repair parts refer to appendix B.

Section III. LUBRICATION INSTRUCTIONS

3-3. General Lubrication Instructions

a. Use lubricating oil, general purpose (PL special) for lubrication above 0°F, and weapons lubricating oil (LAW) for lubrication below 0°F on all parts of the weapon. Prior to firing all interior parts must have a light coat of oil, except the bore which must be wiped dry of any lubrication, and other interior parts that come into contact with ammunition.

b. Refer to table 3-1 for listing of lubrication and cleaning materials and stock numbers for requisitioning purposes.

Table 3-1. Lubrication and Cleaning Materials

Federal stock number	Description
6860-224-6666	CLEANING COMPOUND, RIFLE BORE: (CR) (2 oz can)
6860-224-6667	CLEANING COMPOUND, RIFLE BORE: (CR) (6 oz can)
6860-281-1985	DRY CLEANING SOLVENT: (SD) (1 gal can)

Federal stock number	Description
6860-965-2392	CARBON REMOVING COMPOUND : (P-C-111) (6 gal pail)
7920.206-1711	RAG, WIPING: cotton (60 lb bale)
9150-273-2389	LUBRICATING OIL, GENERAL PURPOSE: (PL special) (4 oz can)
9150-292-9689	LUBRICATING OIL, WEAPONS : (LAW) for below zero operations (1 qt can)

3-4. Specific lubrication Instructions

The following areas must be well lubricated prior to firing the weapon:

- Guide rails of the receiver
- Grooves on the slide

Caution. Prior to loading the weapon, attention should be directed to wiping all visible oil from the pistol grip areas. Excessive oil could cause loss of control during firing.

Section IV. PREVENTIVE MAINTENANCE CHECKS AND SERVICES

3-5. Preventive Maintenance Performed by the Operator

a. The pistol should be inspected (par 3-10b)

each day and cleaned (par 3-10a), if necessary.

b. Refer to table 3-2 for specific preventive maintenance checks and services to be performed by the operator,

Table 3-2. Preventative Maintenance Checks and Services

Item to be inspected	Procedure	Reference
Pistol and Holster	General appearance and proper functioning of component parts. <i>Warning.</i> Before starting an inspection, be sure to clear the weapon. Do not actuate the trigger until the weapon has been cleared. Remove magazine, inspect the chamber to insure that it is empty and check to see that no ammunition is in position to be introduced.	
Safety tests	<p><i>Safety Lock Test.</i> With the pistol unloaded cock the hammer and press the safety upward into the safe (locked) position. Grasp the grip so the grip safety is depressed and squeeze the trigger tightly 3 or 4 times. If the hammer falls, return pistol to organizational maintenance.</p> <p><i>Grip Safety Test.</i> With the pistol unloaded, cock the hammer, and without depressing the grip safety, point the pistol downward and squeeze the trigger 3 or 4 times. If the hammer falls because the grip safety is depressed by its own weight return the pistol to organizational maintenance.</p> <p><i>Half-Cock Position Test.</i> With the pistol unloaded, draw back the hammer until the sear engages the half-cock position notch, then squeeze the trigger. If the hammer falls, return the pistol to organizational maintenance. Draw the hammer back nearly to full cock position, do not squeeze trigger, and then let thumb slip off hammer. The hammer should fall only to the half-cock notch.</p> <p><i>Disconnecter Test.</i></p> <ol style="list-style-type: none"> 1. With the pistol unloaded, cock the hammer, push the slide group 1-1/4 inch to the rear and hold in that position while squeezing trigger. Let slide group go forward, maintaining pressure on trigger. If the hammer falls, return pistol to organizational maintenance. 2. Pull the slide group rearward until slide stop is engaged. Squeeze trigger and release slide group simultaneously. The hammer should not fall, if it does, return pistol to organizational maintenance. 3. Release the pressure on the trigger and then squeeze it. The hammer should then fall, if it does not fall return pistol to organizational maintenance. Also, check for a faulty disconnecter which would prevent the hammer from falling. The disconnecter should prevent the release of the hammer unless the slide group is in a forward position and locked into battery. <p><i>Note.</i> This also prevents the firing of more than one shot with each squeeze of the trigger</p>	<p>Fig 3-1</p> <p>Fig 3-2</p> <p>Fig 3-3 and 2-3</p> <p>Fig 3-5</p>

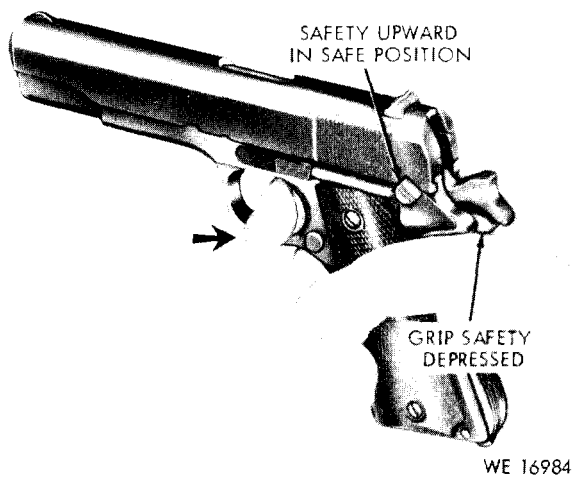

Figure 3-1. Safety lock test.

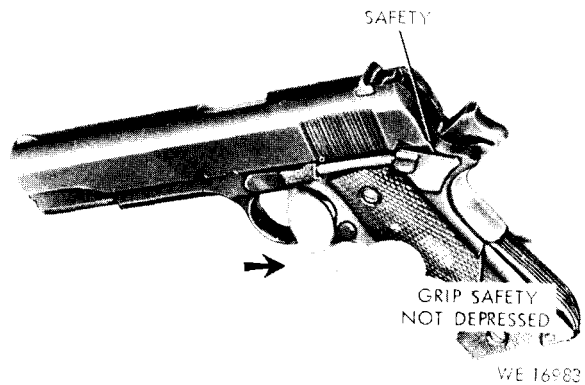

Figure 3-2. Grip safety test.

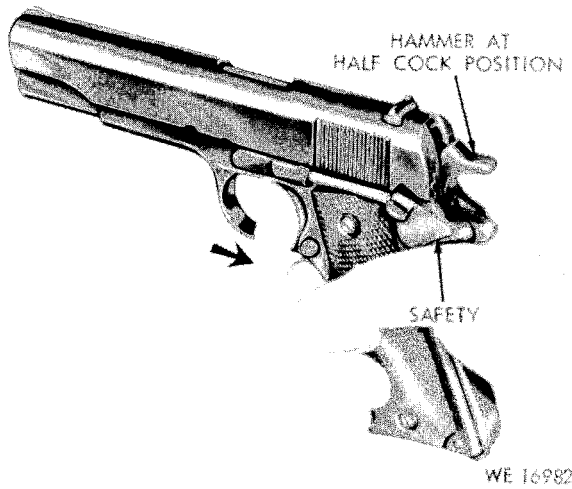

Figure 3-3. Half-cock position test. (1 of 2)

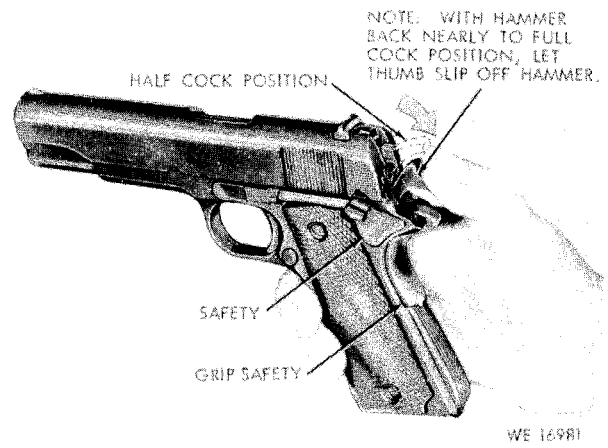
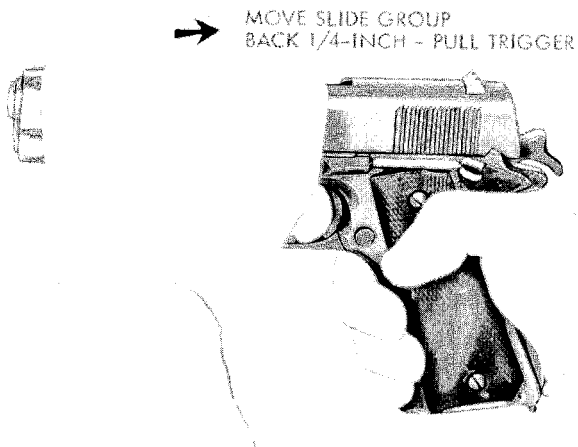
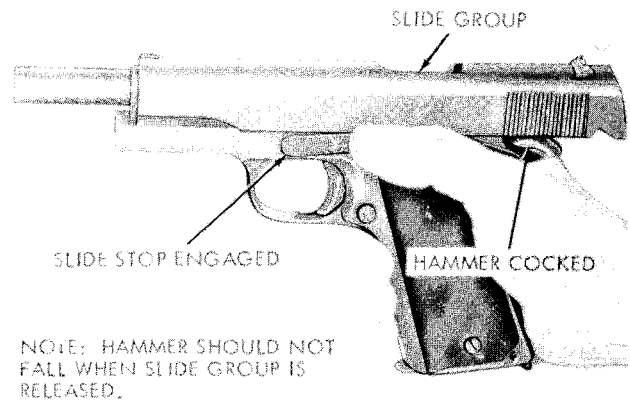

Figure 3-4. Half-cock position test. (2 of 2)



POSITIONING SLIDE GROUP TO DETERMINE IF DISCONNECTOR IS WORN.



SLIDE GROUP IN REARWARD POSITION, PREPARING TO RELEASE SLIDE STOP.

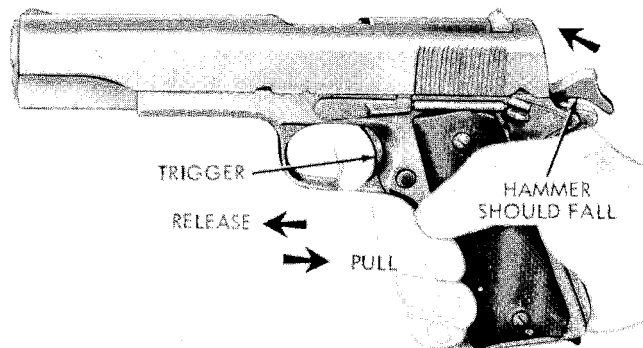

SLIDE GROUP IN FORWARD POSITION PRIOR TO TESTING HAMMER.

WE 16985

Figure 3-5. Disconnecter Test.

3-6. Preventive Maintenance Performed by Organizational Maintenance Personnel

For preventive maintenance checks and services to be performed by organizational maintenance personnel refer to table 3-2. These should be performed weekly. During periods of inactivity perform preventive maintenance, every 90 days, unless inspection reveals more frequent servicing is necessary.

These should be performed weekly. During periods of inactivity perform preventive maintenance, every 90 days, unless inspection reveals more frequent servicing is necessary.

Section V. TROUBLESHOOTING

3-7. Troubleshooting by the Operator

- a. Refer to table 3-3.
- b. Return pistol to organizational maintenance for corrective action not authorized to the operator.

Table 3-3. Troubleshooting by the Operator

Malfunction	Probable cause	Corrective action
Failure to feed	The top cartridge in the magazine is not properly positioned.	Reload magazine.
	Dirty or rusty magazine.	Clean and lubricate.
	Improper assembly of magazine. Broken, damaged or bent parts.	Reassemble, fig 3-9. Replace magazine assy, 1, fig B-1.
Failure to chamber	Obstruction or dirty chamber.	Clean chamber.
Failure to lock	Weak recoil spring.	Par 3-7b.
	The barrel locking ribs do not interlock with the locking recesses in the slide.	Lubricate, par 3-3 and 9-4.
	Lack of lubrication of operating parts. Dirty or burred barrel locking ribs or locking recesses.	Clean, par 3-7b.
Failure to fire	Weak recoil spring.	Par 3-7b.
	Broken barrel link.	Par 3-7b.
	The hammer falls but the primer of the cartridge is not ignited.	Par 3-7b.
Failure to unlock	Bent or broken hammer strut.	Par 3-7b.
	Broken firing pin.	Par 3-7b.
	Weak mainspring.	Par 3-7b.
Failure to extract	The barrel locking ribs do not disengage from the recesses in the slide.	Par 3-7b.
	Broken barrel link.	Par 3-7b.
	Broken link pin.	Par 3-7b.
Failure to eject	Broken barrel lugs.	Par 3-7b.
	The cartridge case is not removed from the chamber.	Clean chamber, par 3-10.
	Dirty chamber, Pitted chamber.	Par 3-7b.
Failure to cock	Broken or worn extractor.	Par 3-7b.
	The cartridge case is not ejected from the pistol.	Par 3-7b.
Miscellaneous	Faulty extractor or ejector.	Par 3-7b.
	Defective sear spring.	Par 3-7b.
Miscellaneous	Worn or broken disconnecter, sear or full cock notch on hammer.	Par 3-7b.
	Two or more shots fired in succession by one trigger squeeze.	Par 3-7b.

3-8. Organizational Troubleshooting

Refer to table 3-4.

Table 3-4. Organizational Troubleshooting.
Probable cause

Malfunction	Probable cause	Corrective action
Failure to chamber	Weak recoil spring.	Par 3-12c(3).
Failure to lock	Dirty or burred barrel locking ribs or locking recesses.	Stone burs; clean, par 3-12 and 8-12c.
Failure to fire	Weak recoil spring.	Par 3-12c(3).
	Broken barrel link.	Replace, 9, fig B-1.
	Bent or broken hammer strut.	Replace, 22, fig B-1.
Failure to unlock	Broken firing pin.	Replace, 11, fig B-1.
	Weak mainspring.	Par 3-12c(3).
Failure to extract	Broken barrel link.	Replace, 9, fig B-1.
	Broken link pin.	Replace, 8, fig B-1.
Failure to eject	Broken barrel lugs,	Par 3-12c (3).
	Pitted chamber,	Par 3-12c (3).
Failure to cock	Broken or worn extractor.	Par 3-12c (3).
	Faulty extractor or ejector,	Par 3-12c (3).
	Defective sear spring.	Replace, 18, fig B-1.
	Worn or broken disconnecter, sear, or full cock notch on hammer.	Par 3-12c(9).

Section VI. OPERATORS MAINTENANCE PROCEDURES

3-9. Disassembly/Assembly Procedures

a. For disassembly/assembly of the weapon authorized to the operator refer to figures 3-6 through 3-8.

Note. White arrows, shown on illustrations, indicate removal or disassembly sequence, and black arrows assembly or installation sequence.

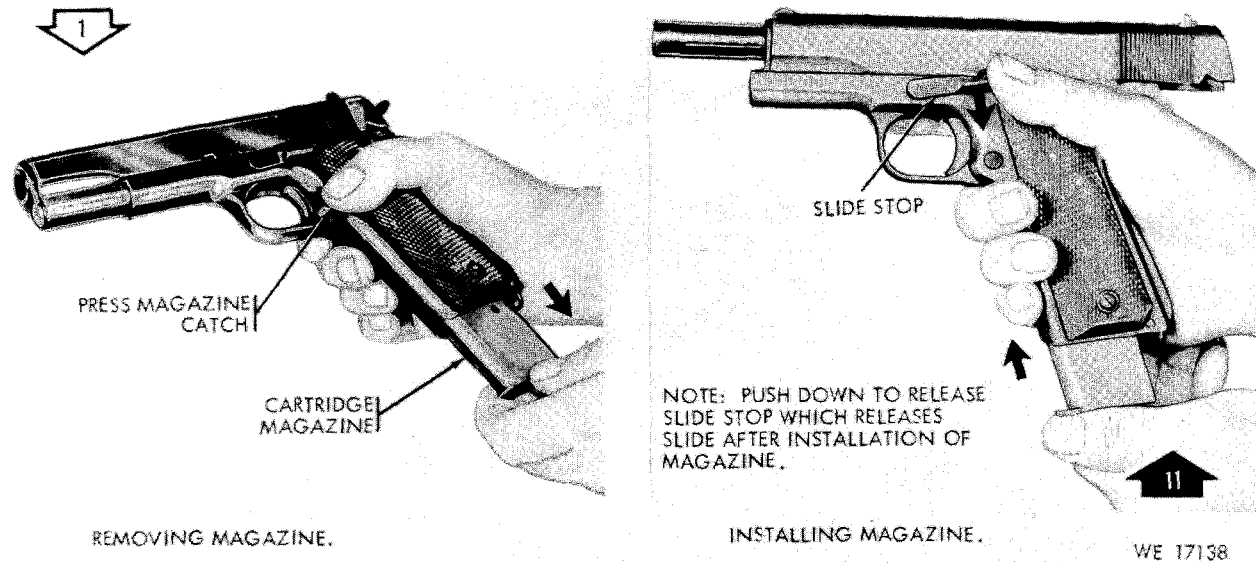
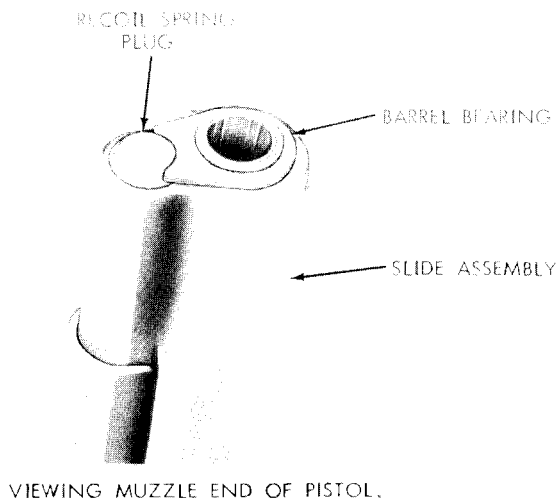
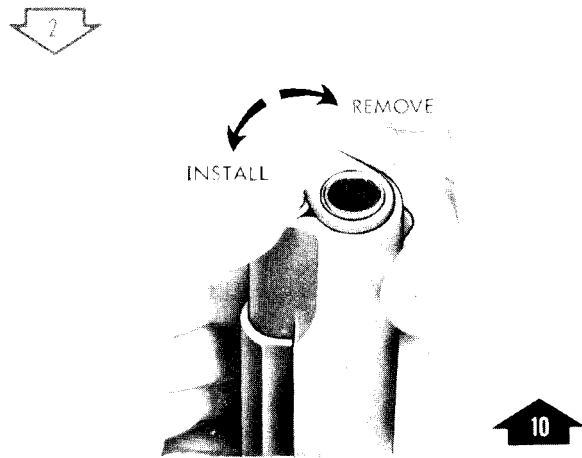

Figure 3-6. Operator's disassembly/assembly of Caliber .45 Automatic pistol, M1911A1. (1 of 3)



VIEWING MUZZLE END OF PISTOL.



COMPRESS RECOIL SPRING PLUG AND ROTATE BARREL BEARING.

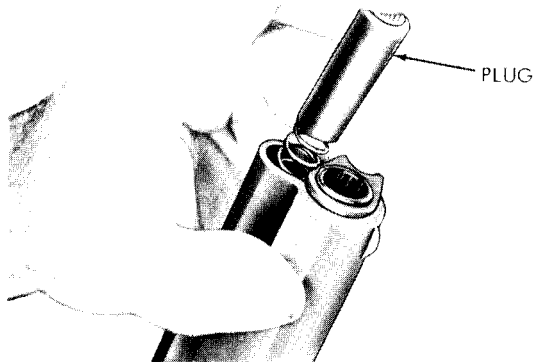

REMOVE/INSTALL RECOIL SPRING PLUG AND SPRING.

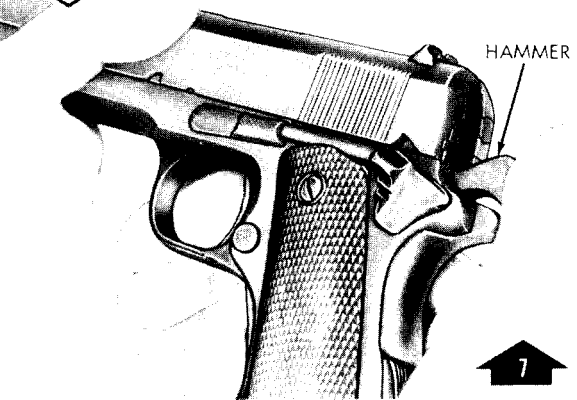
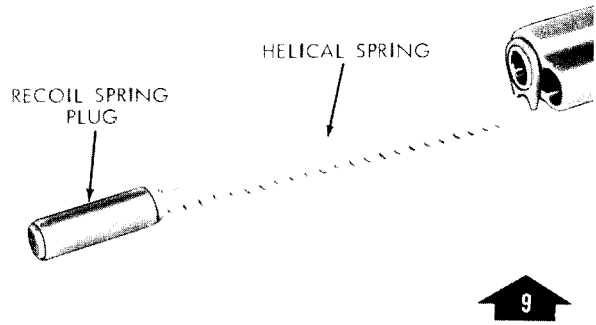

COCK HAMMER FOR REMOVING/INSTALLING SLIDE GROUP.

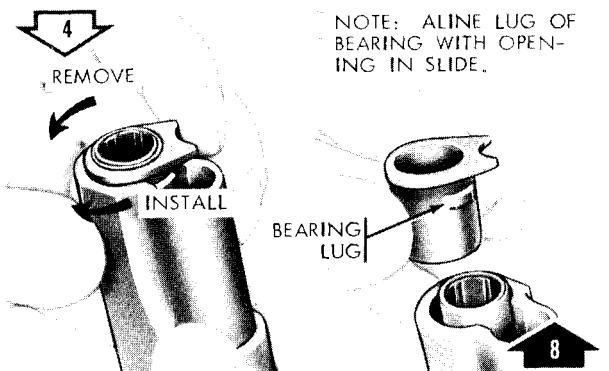

A - TURN BEARING CLOCKWISE TO REMOVE, COUNTERCLOCKWISE TO INSTALL. B - BEARING POSITIONED FOR INSTALLATION/REMOVAL.

REMOVE/INSTALL BARREL BEARING.

WE 17139

Figure 3-7. Operator's disassembly/assembly of Caliber .45 Automatic Pistol, M1911A1. (2 of 3)

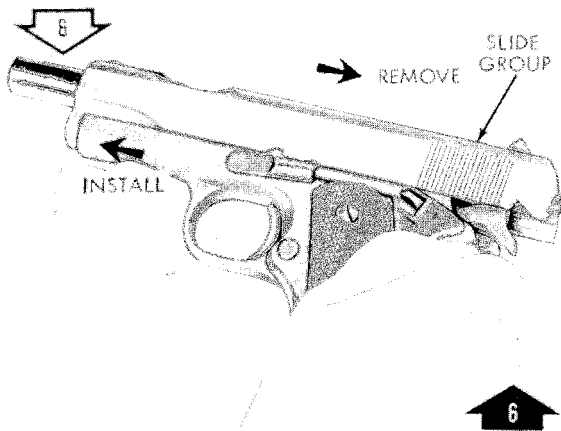

POSITION SLIDE GROUP.

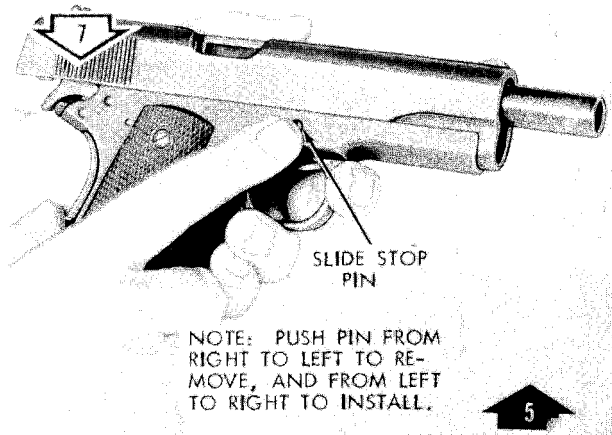

UNSEAT/SEAT PIN PORTION OF SLIDE STOP.

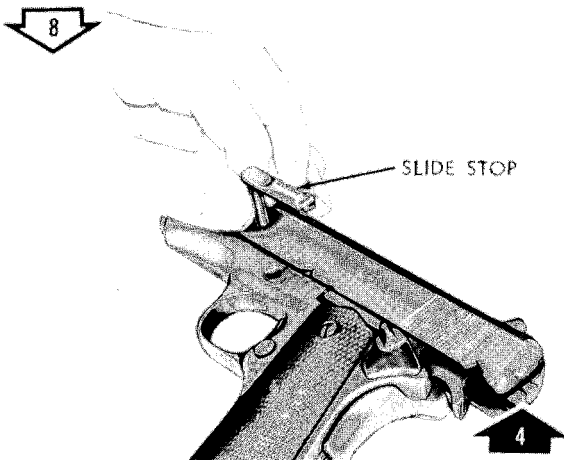

REMOVE/INSTALL SLIDE STOP.

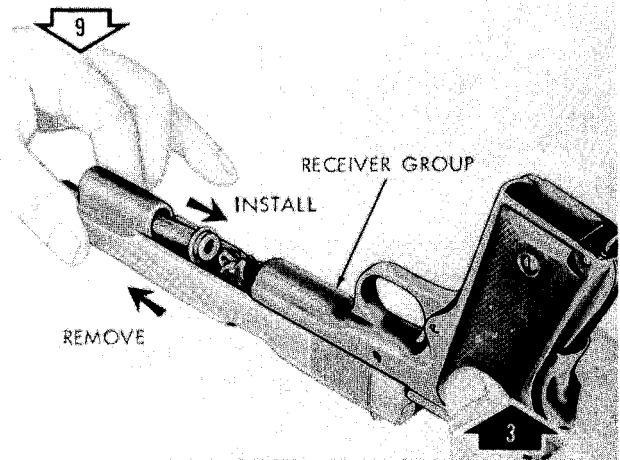

REMOVE/INSTALL SLIDE GROUP FROM RECEIVER GROUP.

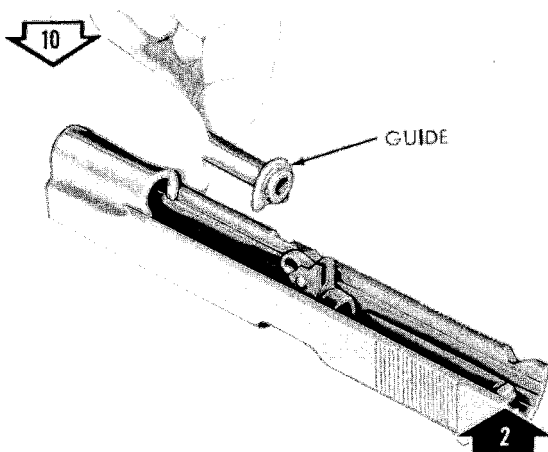

REMOVE/INSTALL RECOIL SPRING GUIDE.

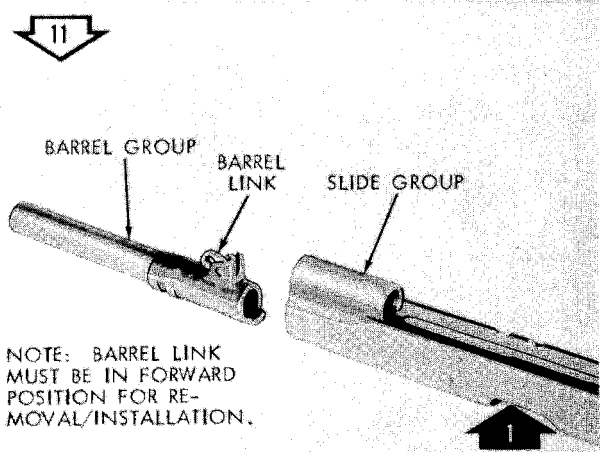

REMOVE/INSTALL BARREL GROUP.

WE 17140

Figure 3-8. Operator's disassembly/assembly of Caliber .45 Automatic Pistol, M1911A1. (3 of 3)

b. To test the pistol, for correct assembly, pull the slide fully to the rear and release it, the hammer should remain cocked. Hold the pistol in a normal grasp to depress the grip safety and squeeze the trigger. The hammer should fall.

3-10. Cleaning, Inspection and Repair

a. Cleaning.

(1) *General.* Disassemble the pistol and clean all parts with a rag saturated with dry cleaning solvent (SD). Dry parts, apply a light coat of oil and assemble the pistol. The pistol should be inspected each day.

(2) *Cleaning after firing.* The pistol must be thoroughly cleaned as soon as possible, after firing, in the following manner.

(a) Disassemble the pistol.

(b) Clean all parts with dry cleaning solvent (SD), dry all parts and apply a light coat of oil.

(c) Clean the bore and chamber as follows :

1. Wet a swab with rifle bore cleaning compound (CR) and run it back and forth through the bore several times.

2. Attach the pistol bore brush (1, fig B-2) to the cleaning rod (2, fig B-2)

and run it through the bore and chamber several times.

3. Run dry swabs through the bore and chamber until they are clean.

4. Inspect the bore for cleanliness. If it is not free of all residue, repeat the cleaning process,

5. When the chamber and bore are clean, coat them with rifle bore cleaning compound (CR) and leave overnight.

6. Assemble the pistol.

7. Perform the test for correct assembly (par 3-9b).

8. Apply a light coat of oil to the exterior surfaces of the pistol.

b. *Inspection.* The operator should daily inspect the weapon. Particular attention should be directed to making sure the pistol is free from rust, any foreign matter, and that it is clean. Refer in table 3-2 for detailed procedures that are applicable to inspections as well as preventive maintenance.

c. Repair,

(1) Operator's repairs to the weapon will be limited to replacement of the magazine. The magazine can be disassembled in accordance with figure 3-9 for cleaning purposes.

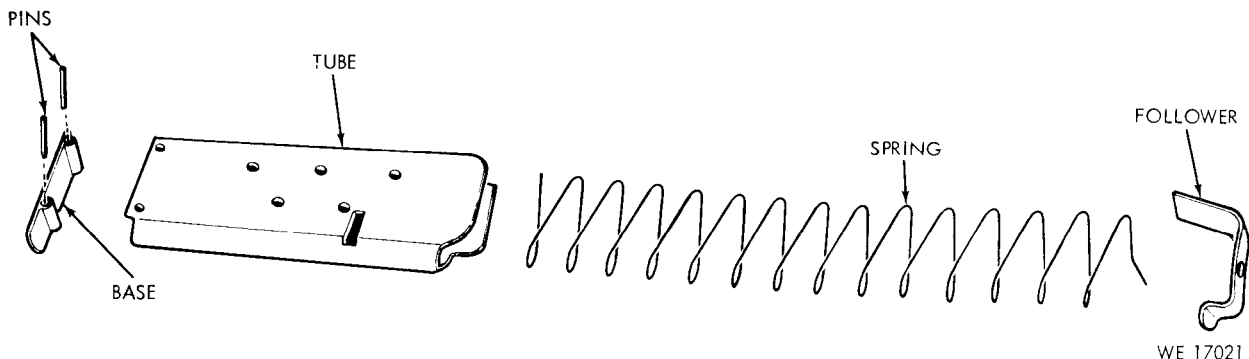

Figure 3-9. Magazine assembly-exploded view.

(2) For repairs other than authorized above, return pistol to organizational maintenance personnel.

Note. Magazine assembly (old manufacture) shown for disassembly cleaning purposes. New **manufactured** magazine **assembly has welded base.**

Section VII. ORGANIZATIONAL MAINTENANCE PROCEDURES

3-11. Disassembly/Assembly Procedures
Refer to figures 3-10 through 3-15 for

detailed procedures on disassembly/assembly of the pistol.

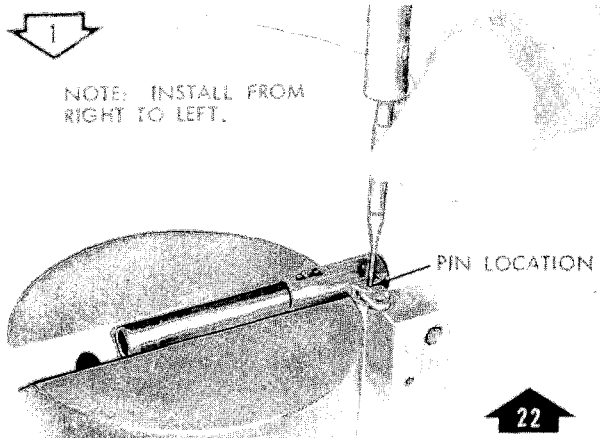

REMOVE/INSTALL BARREL LINK PIN.

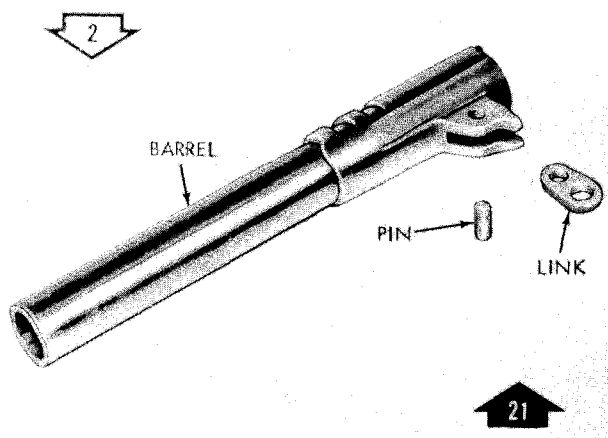

REMOVE/INSTALL BARREL LINK.

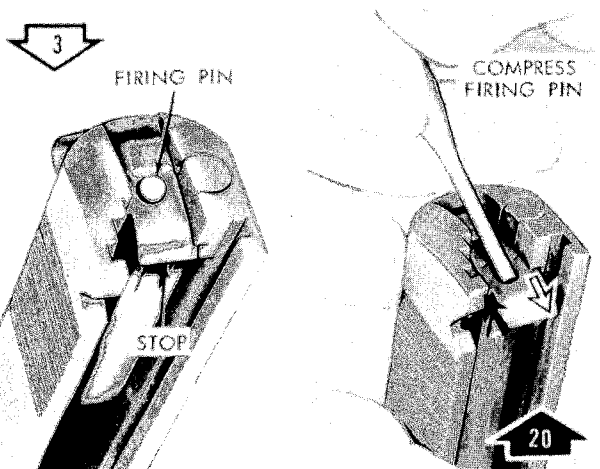

A - FIRING PIN AND STOP. B - COMPRESS FIRING PIN TO REMOVE/INSTALL STOP.
REMOVE/INSTALL FIRING PIN STOP.

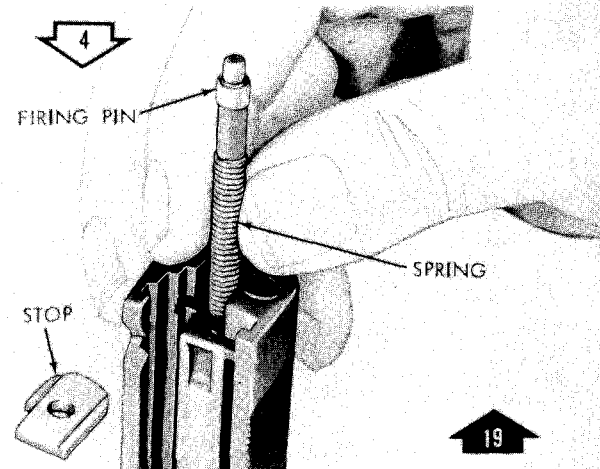

REMOVE/INSTALL FIRING PIN AND FIRING PIN SPRING.

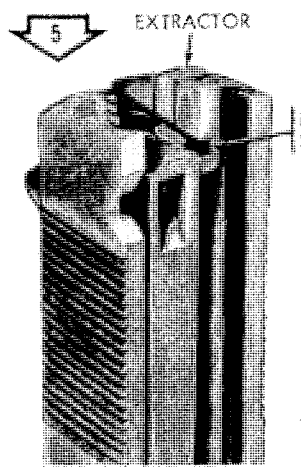

A - CORRECT LOCATION OF EXTRACTOR AT FIRING PIN STOP SLOT.

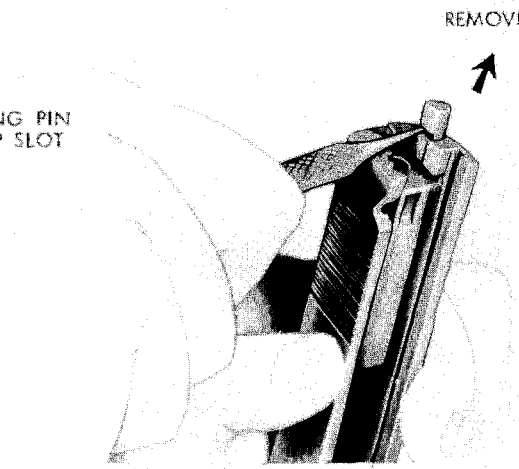

B - UNSEAT/SEAT EXTRACTOR.

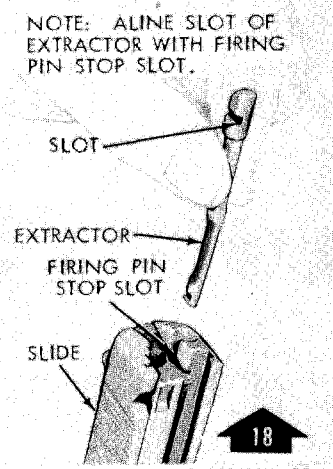

C - EXTRACTOR POSITIONED.

REMOVE/INSTALL CARTRIDGE EXTRACTOR.

WE 17131

Figure 3-10. Organizational disassembly/assembly of Caliber .45 Automatic Pistol, M1911A1. (1 of 6)

6

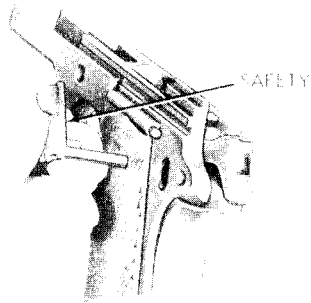

REMOVE SAFETY.

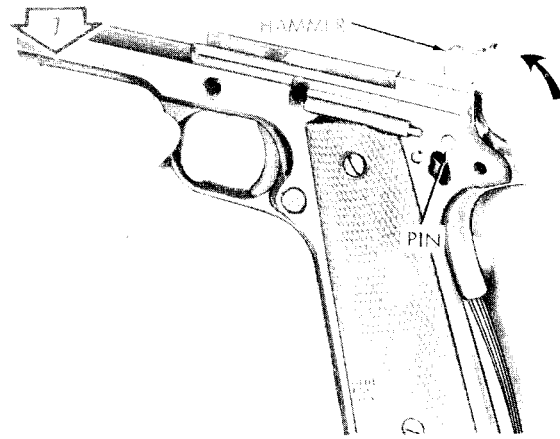

RELEASE HAMMER PRIOR TO REMOVING HAMMER PIN.

8

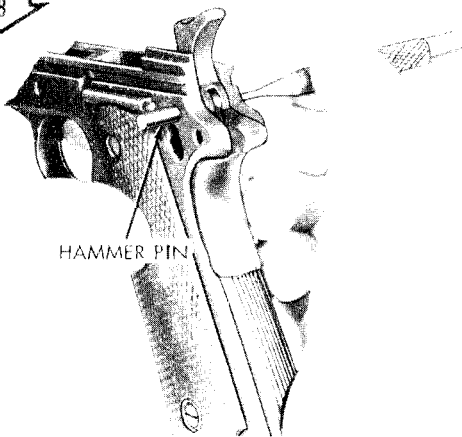

REMOVE HAMMER PIN.

9

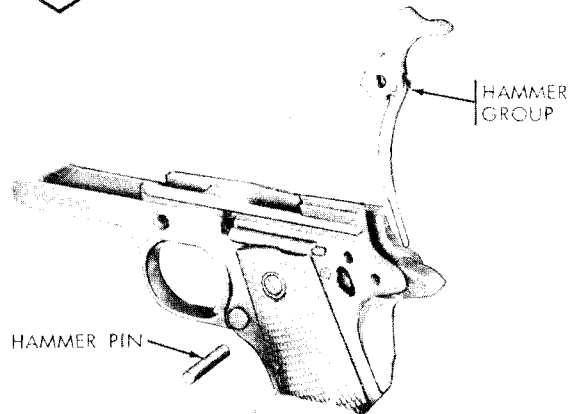

REMOVE HAMMER GROUP.

10

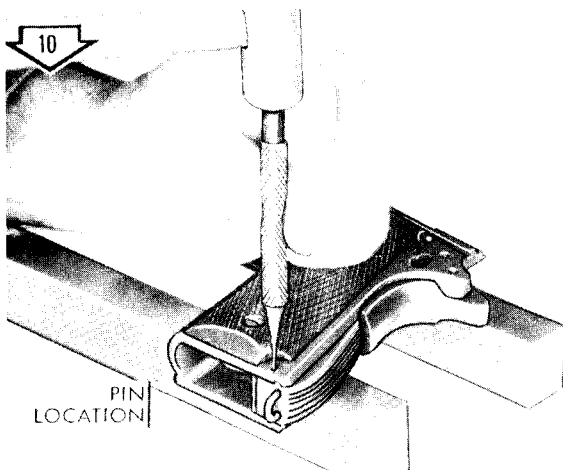

REMOVE MAINSPRING HOUSING PIN.

11

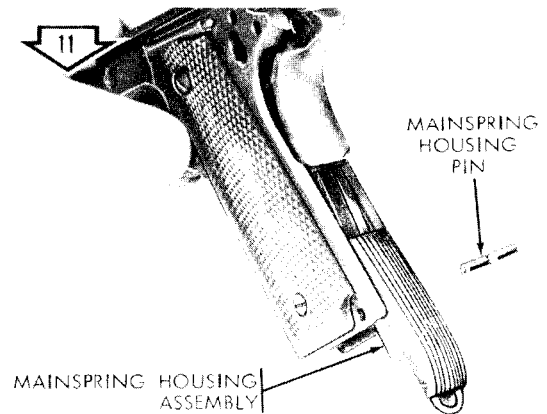

REMOVE MAINSPRING HOUSING ASSEMBLY.

WE 17132

Figure 3-11. Organizational disassembly/assembly fo Caliber .45 Automati Pistol, M 1911A1. (2 of 6)

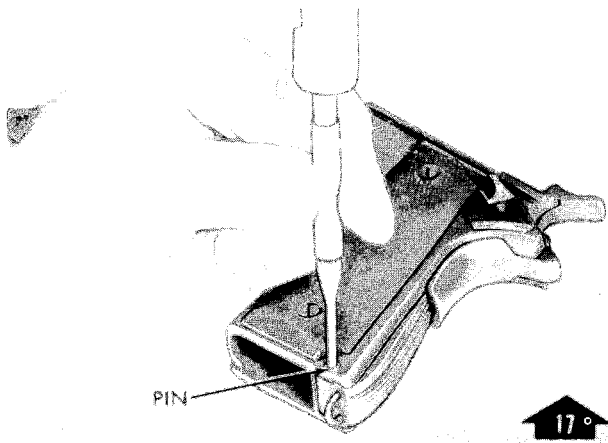

INSTALL MAINSPRING HOUSING PIN.

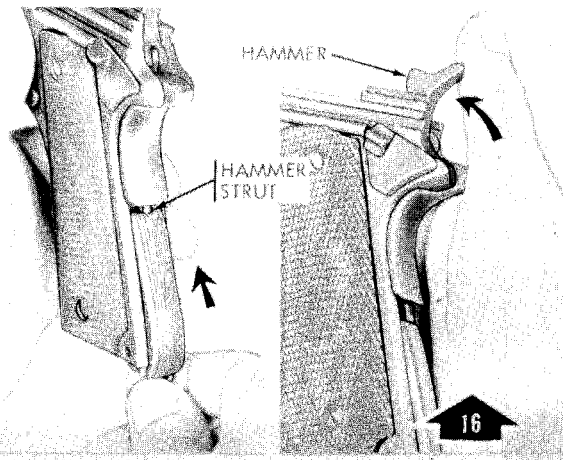

RELEASE HAMMER AND POSITION HAMMER STRUT INTO MAINSPRING HOUSING ASSEMBLY.

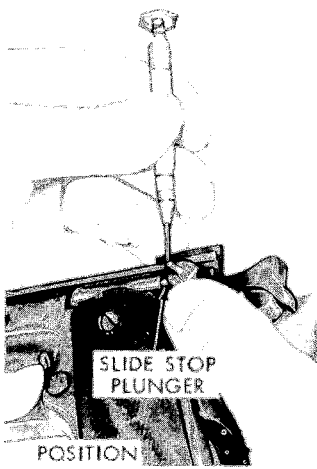

POSITION

POSITION AND INSTALL SAFETY.



INSTALL

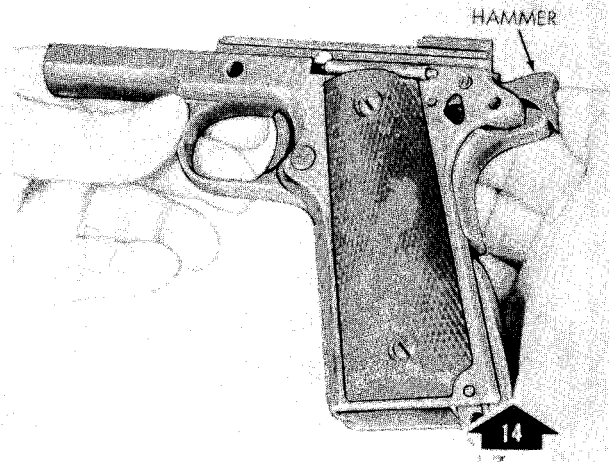

COCK HAMMER PRIOR TO INSTALLING SAFETY.

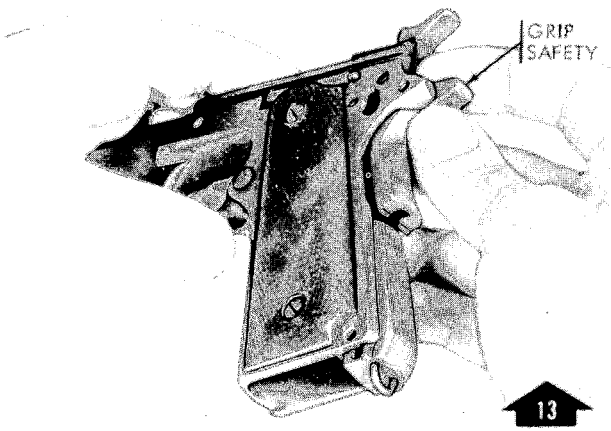

DROP HAMMER STRUT AND INSTALL GRIP SAFETY.

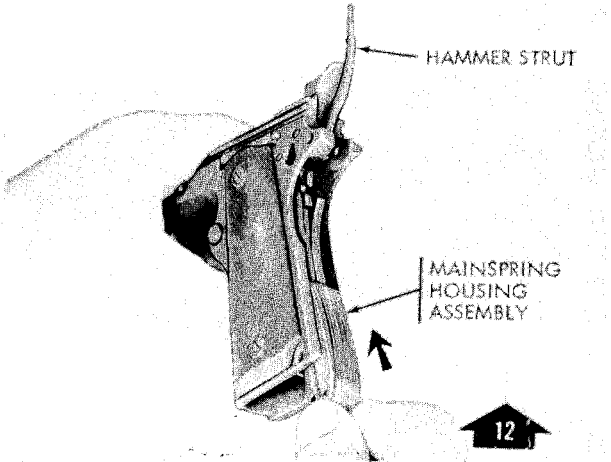

PARTIALLY INSTALL MAINSPRING HOUSING ASSEMBLY TO HOLD SEAR SPRING IN POSITION.

WE 17133

Figure 3-12. Organizational disassembly/assembly fo Caliber .45 Automtnc Pistol, M1911A1. (3 of 6)

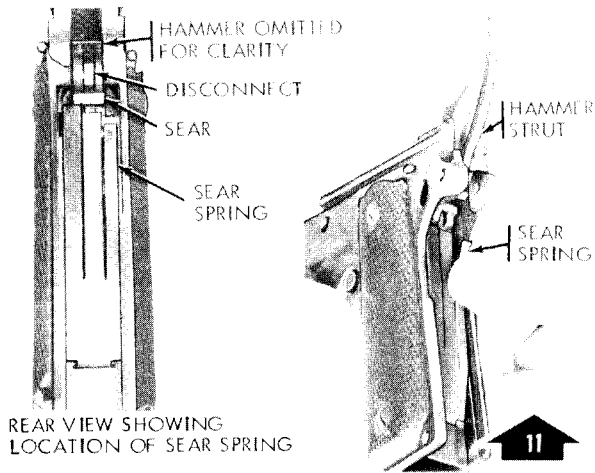

REAR VIEW SHOWING LOCATION OF SEAR SPRING

RAISE HAMMER STRUT AND INSTALL SEAR SPRING.

NOTE: WHEN INSTALLING HEAD OF PIN SHOULD BE ON LEFT SIDE.

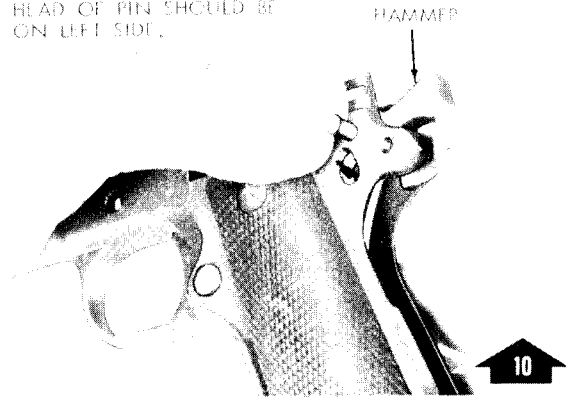

INSTALL HAMMER AND HAMMER PIN.

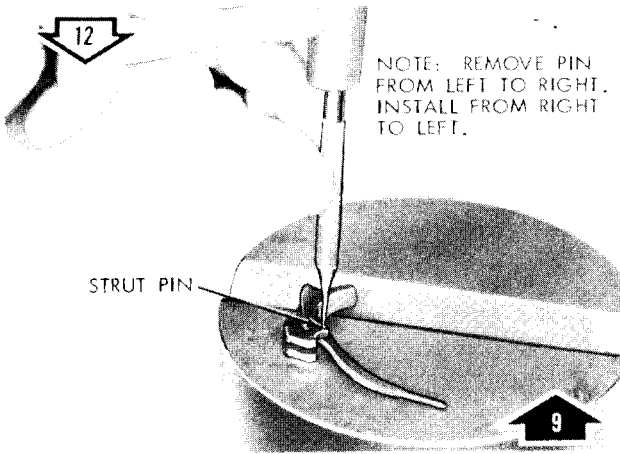

NOTE: REMOVE PIN FROM LEFT TO RIGHT. INSTALL FROM RIGHT TO LEFT.

REMOVE/INSTALL HAMMER STRUT PIN.

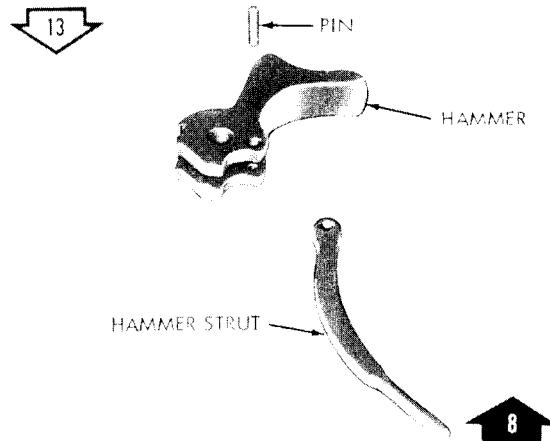

SEPARATE CONNECT HAMMER STRUT AND HAMMER.

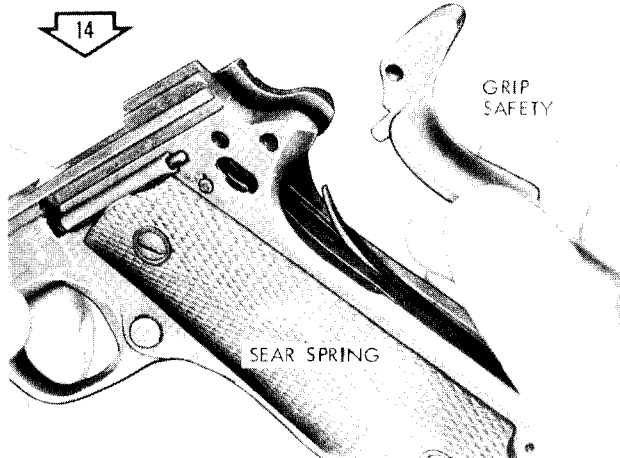

REMOVE GRIP SAFETY.

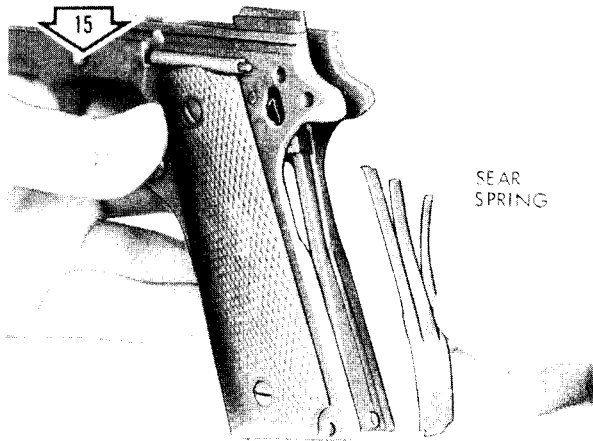

REMOVE SEAR SPRING.

WE 17134

Figure 3-13 Organizational disassembly/assembly of Caliber .45 Automatic Pistol, M1911A1. (4 of 6)

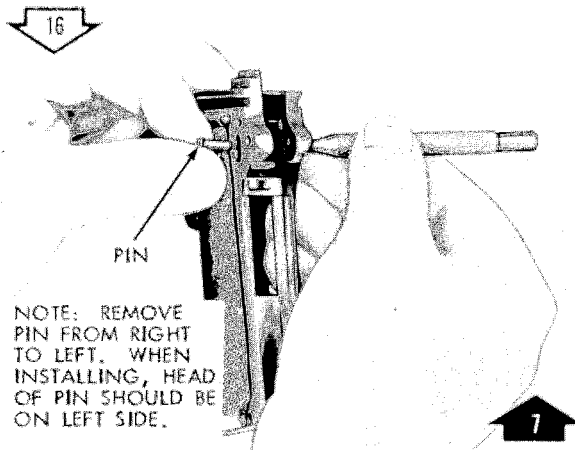

NOTE: REMOVE PIN FROM RIGHT TO LEFT. WHEN INSTALLING, HEAD OF PIN SHOULD BE ON LEFT SIDE.

REMOVE/INSTALL SEAR PIN.

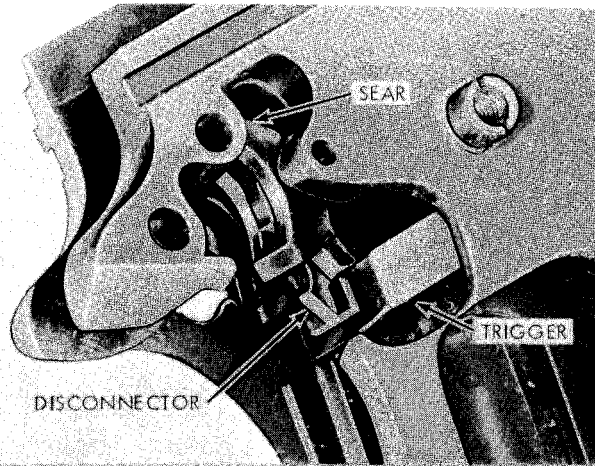

CUTAWAY VIEW SHOWING LOCATION OF SEAR AND DISCONNECTOR.

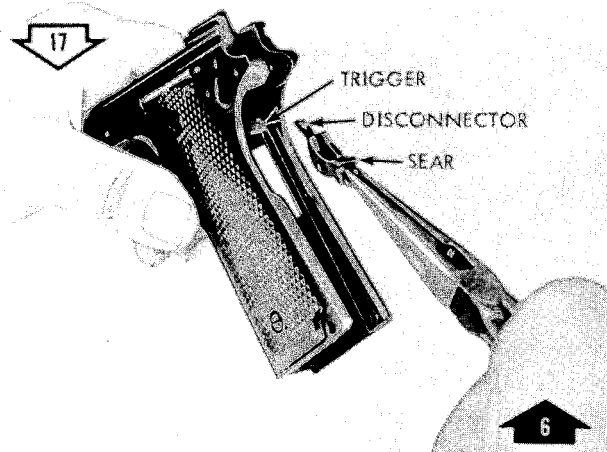

REMOVE/INSTALL SEAR AND DISCONNECTOR.

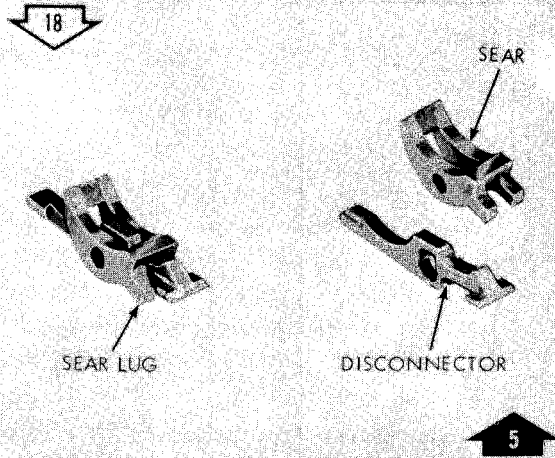

SEPARATE/CONNECT SEAR AND DISCONNECTOR.

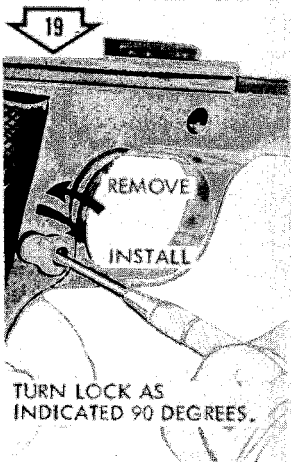

TURN LOCK AS INDICATED 90 DEGREES.

UNLOCK/LOCK CATCH GROUP.

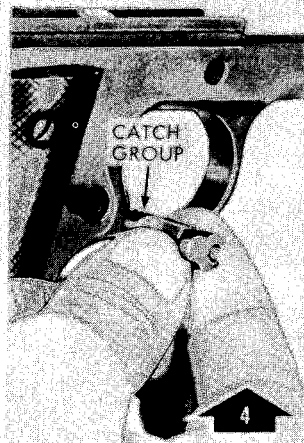

POSITIONING CATCH GROUP.



REMOVE/INSTALL TRIGGER.

REMOVE/INSTALL MAGAZINE CATCH GROUP.

WE 17135

Figure 3-14. Organizational disassembly/assembly of Caliber .45, Automatic Pistol, M1911A1. (5 of 6)

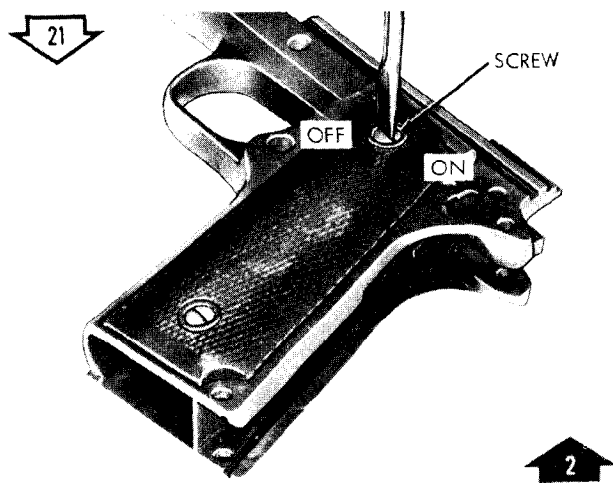

REMOVE/INSTALL GRIP SCREWS.

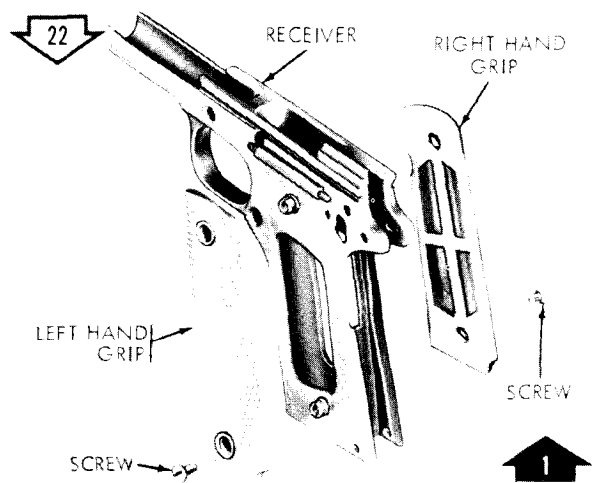

REMOVE/INSTALL PLASTIC GRIPS.

WE 17136

Figure 3-15. Organizational disassembly/assembly of Caliber .45, Automatic Pistol, M1911A1. (6 of 6)

3-12. Cleaning, Inspection and Repair

a. **Cleaning.** For general cleaning instructions refer to TM 9-208-1 and TM 9-247. For specific cleaning procedures refer to paragraph 3-10a. On those component parts which contain a hard carbon residue it may be necessary to clean the parts with carbon removing compound, P-C-111. Observe the following procedures when using P-C-111,

Warning. Avoid skin contact with P-C-111. The compound should be washed off thoroughly with running water if it comes in contact with the skin. A good lanolin base cream, after exposure to the compound, is helpful. The use of rubber gloves and protective equipment is recommended.

(1) Using a suitable container, fill with fresh compound.

(2) Before soaking parts in the compound, remove all loose dirt, grease, and oil. Place parts to be cleaned in the container, making certain they are completely immersed.

(3) Depending on the amount of residue to be removed, soak for 2 to 16 hours,

(4) Rinse parts with water and dry clean-

ing solvent (SD), and brush with a stiff bristle' brush.

(5) Wipe parts dry and lubricate (par 3-3 and 3-4).

b. Inspection.

Warning. Clear the weapon of all ammunition before starting an inspection. Remove the magazine and check the chamber to insure it is empty. Do NOT actuate the trigger until the weapon has been cleared.

Refer to table 3-5 for inspection and repair procedures.

c. Repair.

(1) Remove burs, rough spots, rust and scored areas with a fine stone or crocus cloth moistened with oil. When stoning, care must be taken not to alter any surfaces from the original dimensions.

(2) Replace only those parts which are authorized to organizational maintenance personnel. (Refer to appendix B.)

(3) For repair or replacement of parts, not authorized for organizational maintenance, return pistol to direct support personnel.

(4) For specific repair functions refer to table 3-5.

Table 3-5. Inspection and Repair Procedure

Component part or assembly	Inspection	Repair	Reference
Pistol	Overall condition: Nicks, scratches, and burs. Rust or dirt	Stone or use crocus cloth. Clean and lubricate.	Par 3-12c (1) Par 3-12a, 3-3 and 3-4
	Check safety and disconnect tests.		Table 3-2
Magazine Assembly	Rust or dirt.	Clean and lubricate.	Par 3-12a, 3-3 and 3-4
	Proper assembly, Dull black finish, damaged parts, and proper functioning.	Assemble properly, Replace magazine assembly.	Par 3-9 and 3-11 1, fig B-1
Slide Group	Damaged parts.	Replace only items 8, 9, 11, and 12, fig B-1, if damaged.	Par 3-12c (2)
	Recoil spring must have a free overall length of 6-1/2 inches.		Par 3-12c (3)
	Check for loose sights Rust, dirt or foreign matter.	Clean and lubricate.	Par 3-12c (3) Par 3-12a, 3-3 and 3-4
Receiver Group	Damaged parts.	Replace only items 18, 22, 26, 27, 28, and 30, fig B-1, if damaged.	Par 3-12c (2) and (3)
	Rust, dirt or foreign matter.	Clean and lubricate.	Par 3-12a, 3-3 and 3-4
Holster	Leather will be soft and pliable, free from tears, cuts and cracks. Stitching will be secure and must have all snaps, hooks and pads in place.	Leather material after being water soaked should be cleaned with saddle soap after drying in the shade. Apply mildew preservative leather dressing for field treatment.	3 or 4, fig B-2

Note. Brass portions and surrounding leather will be free of verdigris. Leather will be black.

CHAPTER 4
AMMUNITION

4-1. General

Ammunition for the Caliber .45 Automatic Pistol, M1911A1 is issued in the form of a complete round. A complete round (cartridge) consists of all the components (cartridge case, bullet, propellant powder, and primer) necessary to fire the weapon once.

4-2. Classification and Identification of Ammunition

The contents of original boxes or containers can be identified by markings on the box. These markings indicate the number of cartridges in the container, the caliber, the type, the code symbol, and the lot number. The types, uses and means of identification of ammunition for use in the pistol are:

a. Cartridge, Caliber .45, Ball, M1911, is for use against personnel and light material targets. The ball bullet consists of a metal jacket surrounding a lead alloy core. The bullet tip is unpainted.

b. Cartridge, Caliber .45, Blank, M9, is used

to simulate fibre and for salutes. This cartridge can be fired single shot only in the pistol. It can be identified by the absence of a bullet and by its tapered mouth.

c. Cartridge, Caliber .45, Dummy, M1921, is used for training personnel in the operation of loading and unloading the pistol, and for testing weapons. This cartridge can be identified by the empty primer pocket and two holes in the cartridge case.

d. Cartridge, Caliber .45, Tracer, M26 is used for observation of fire. Secondary uses are for incendiary effect and for signaling. The bullet consists of three parts: a copper-plated or gilding metal-clad steel jacket, a slug of lead hardened with antimony and a tracer mixture in the rear portion of the jacket. The bullet is painted red for a distance of approximately 3/16 inch from the tip.

e. Cartridge, Caliber .45, High Density Shot, XM261 is used against personnel. It employs 16 spheres incased in a sabot similar in shape to the ball bullet.

CHAPTER 5

DEMOLITION TO PREVENT ENEMY USE

5-1. General

a. Destruction of the pistol when subject to capture or abandonment in the combat zone, will be undertaken only when in the judgment of the commander concerned such action is necessary. If destruction is resorted to, the equipment must be so badly damaged that it cannot be restored to a usable condition in the combat zone either by repair or cannibalization. The reporting of the destruction of equipment

is to be through regular channels.

b. Priorities for destruction of parts are:

- (1) Firing pin
- (2) Barrel
- (3) Slide assy w/sights
- (4) Receiver

c. The same priority for the destruction of component parts of the pistol are to be given to the destruction of similar components in spare parts storage areas.

APPENDIX A
REFERENCES

A-1. Publication Indexes

The following indexes should be consulted frequently for the latest changes or revision of references given in this appendix and for new publications relating to material covered in this manual.

Military Publications:

Index of Administrative Publications	DA Pam 310-1
Index of Army Films, Transparencies, GTA Charts, and Recordings	DA Pam 108-1
Index of Doctrinal, Training and Organizational Publications	DA Pam 310-3
Index of Technical Manuals, Technical Bulletins, Supply Manuals (types 7,8 and 9) Supply Bulletins and Lubrication Orders	DA Pam 310-4

A-2. Forms

DA Form 2028, Recommended Changes to DA Publications

DA Form 2407, Maintenance Request

DD Form 6, Report of Damage or Improper Shipment

A-3. Other Publications

The following explanatory publications pertain to this material.

a. General.

Pistols and Revolvers FM 23-35

Army Equipment Record Procedures TM 38-750

b. Cleaning.

Cleaning of Ordnance Materiel TM 9-208-1

c. Safety.

Accident Reporting and Records AR 385-40

APPENDIX B

BASIC ISSUE ITEMS LIST AND ORGANIZATIONAL MAINTENANCE REPAIR PARTS AND SPECIAL TOOLS LIST

Section I. INTRODUCTION

B-1. Scope

This appendix lists basic issue items, repair parts and special tools required for the performance of organizational maintenance of the Caliber .45 Automatic Pistol, M1911A1 with hip holster and Caliber .45 Automatic Pistol, M1911A1 with shoulder holster.

B-2. General

This Basic Issue Items, Repair Parts, and Special Tools List is divided into the following sections:

a. Basic Issue Items—Section II. A list of items which accompany the pistols.

b. Maintenance and Operating Supplies—Section III. A listing of maintenance and operating supplies required for initial operation.

e. Prescribed Load Allowance (PLA)—Section IV. A composite listing of repair parts and special tools having quantitative allowances for initial stockage at the organizational level.

d. Repair Parts—Section V. A list of repair parts authorized for the performance of maintenance at the organizational level in figure and item number sequence,

e. Special Tools and Support Equipment—Section VI. A list of special tools and support equipment authorized for the performance of maintenance at the organizational level.

f. Federal Stock Number and Reference Number Index—Section VII. A list of Federal stock numbers in ascending numerical sequence, followed by a list of reference numbers appearing in all the listings, in ascending alpha-numeric sequence, cross-referenced to the illustration figure number and item number,

B-3. Explanation of Columns

The following provides an explanation of columns in the tabular lists in Sections II through VI,

a. Source, Maintenance, and Recoverability Codes (SMR).

(1) *Source Code.* Indicates the selection status and source for the listed item. Source code used is:

<i>Code</i>	<i>Explanation</i>
P	Applied to repair parts which are stocked in or supplied from Army supply system.

(2) *Maintenance Code.* Indicates the lowest category of maintenance authorized to install the listed item. The maintenance level codes are:

<i>Code</i>	<i>Explanation</i>
C	Operator/crew
O	Organizational

(3) *Recoverability Code.* Indicates whether unserviceable items should be returned for recovery or salvage. Items not coded are expendable. Recoverability code is:

<i>Code</i>	<i>Explanation</i>
R	Applied to repair parts and assemblies which are economically repairable and are furnished by supply on an exchange basis.

b. Federal Stock Number. Indicates the Federal stock number assigned to the item and will be used for requisitioning purposes.

c. Description. Indicates the Federal item name and any additional description of the item required. The abbreviation “w/e” when used as a part of the nomenclature, indicates the Federal stock number includes all armament, equipment, accessories and repair parts issued with the item. A part number or other reference number is followed by the applicable five-digit Federal supply code for manufacturers in parentheses.

d. Unit of Measure (U/M). A 2 character alphabetic abbreviation indicating the amount or quantity of the item upon which the allowances are based, e.g., ft, ea, pr, etc.

e. *Quantity Incorporated in Unit.* Indicates the quantity of the item used in the functional group.

f. *Quantity Furnished with the Equipment.* Indicates the quantity of an item furnished with the equipment (BIIL only).

g. *Component Application.* Identifies the component application of each maintenance or operating supply item (M & O supplies only).

h. *Quantity Required for Initial Operation.* Indicates the quantity of each maintenance or operating supply item required for initial operation of the equipment (M & O supplies only).

i. *Quantity Required for 8 Hours Operation.* Indicates the estimated quantities required for an average 8 hours of operation (M & O supplies only).

j. *Notes.* Indicates informative notes keyed to data appearing in a preceding column (M & O supplies only).

k. *15-Day Organizational Maintenance Allowances.*

(1) The allowance columns are divided into four subcolumns. Indicated in each subcolumn opposite the first appearance of each item is the total quantity of items authorized for the number of equipments supported. Subsequent appearances of the same item will have the letters "REF" in the allowance columns. Items authorized for use as required but not for initial stockage are identified with an asterisk in the allowance column.

(2) The quantitative allowances for organizational level of maintenance represents one initial load for a 15-day period for the number of equipments supported. Units and organizations authorized additional prescribed loads will multiply the number of prescribed loads authorized by the quantity of repair parts reflected in the appropriate density column to obtain the total quantity of repair parts authorized.

(3) Organizational units providing maintenance for more than 100 of these equipments shall determine the total quantity of parts required by converting the equipment quantity to a decimal factor by placing a decimal point before the next to last digit of the number to indicate hundredths, and multiplying the decimal factor by the parts quantity authorized in

the 51-100 allowance column. Example, authorized allowance for 51-100 equipments is 12; for 140 equipments multiply 12 by 1.40 or 16.80 rounded off to 17 parts required.

(4) Subsequent changes to allowances will be limited as follows: No change in the range of items is authorized. If additional items are considered necessary, recommendation should be forwarded to Commanding General, Headquarters, U.S. Army Weapons Command, ATTN: AMSWE-SMM-SA, Rock Island, Illinois 61201, for exception or revision to the allowance list. Revisions to the range of items authorized will be made by the U.S. Army Weapons Command based upon engineering experience, demand data, or TAERS information.

l. *Illustration.*

(1) *Figure Number.* Indicates the figure number of the illustration in which the item is shown.

(2) *Item Number.* Indicates the call-out number used to reference the item in the illustration.

B-4. Special Information

Identification of the usable on codes of this publication are:

<i>Code</i>	<i>Used on</i>
	Parts without any code are used on either the Pistol, Caliber .45, Automatic, M1911A1 with Hip Holster or Pistol, Caliber .45, Automatic M1911A1 with Shoulder Holster.
A	Pistol, Caliber .45, Automatic, M1911A1 with hip holster only.
B	Pistol, Caliber .45, Automatic, M1911A1 with shoulder holster only.

B-5. How to Locate Repair Parts

a. When Federal stock number or reference number is unknown:

(1) *First.* Find illustration B-1 covering the Caliber .45 Automatic Pistol, M1911A1.

(2) *Second.* Identify the repair part on the illustration and figure and item number of the repair part.

(3) *Third.* Using the Repair Parts Listing locate the illustration figure and item number noted on the illustration.

b. When Federal stock number or reference number is known:

(1) *First.* Using the Index of Federal Stock Numbers and Reference Numbers find the pertinent Federal stock number or reference number. This index is in ascending FSN sequence followed by a list of reference numbers in alpha-numeric sequence, cross-referenced to the illustration figure number and item number.

(2) *Second.* Using the Repair Part Listing, find the illustration figure number and item number referenced in the Index of Federal Stock Numbers and Reference Numbers.

B-6. Abbreviations

<i>Abbreviations</i>	<i>Exp[anation]</i>
fil-hd	fillister head
NS	American National Special Thread
o/a	over-all
phos-ctd	phosphate coated
S	steel

B-7. Federal Supply Codes for Manufacturers

Codes	Manufacturers
19204	Rock Island Arsenal Rock Island, Ill. 61201
19205	Springfield Armory Springfield, Mass. 01101
73277	E.F. Houghton and Co 303 W. Lehigh Ave Philadelphia, Pa. 19133
81348	Federal Specifications
81349	Military Specification
98308	Bray Oil Co 3344 Medford St Los Angeles, Calif. 90063

Section II. BASIC ISSUE ITEMS LIST

Source Maint. Recov.		(3)		(4)	(5)	(6)	(7)	
		Reference No. & Mfr. Code	Usable On Code	Unit Of Meas	Qty. Inc. In Unit	Qty. Furn. With Equip	(a) Fig. No.	(b) Item No.
P	C	1005-550-8694		EA	1	2	B-1	1
		1005-550-4036		EA	1	B-2	1
		1005-556-4102		EA	1	B-2	2
		1095-592-6491		EA	1	B-2	3
		1095-973-2353		EA	1	B-2	4

Section III. MAINTENANCE AND OPERATING SUPPLIES

(1) Component Application	(2) Federal Stock No.	(3) Description	(4) Qty. Required For Initial Operation	(5) Qty. Required For 8 Hours Operation	(6) Notes
GENERAL APPLICATION	1005-288-3565	SWAB, SMALL ARMS CLEANING (1000 PER PG)	*		

Section IV. PRESCRIBED LOAD ALLOWANCE

(1) Federal Stock No.	(2) Description Usable On Code	(3) Qty. Inc. In Unit Pack	(4) 15-Day Organizational Maint. Allowance			
			(a) 1-5	(b) 6-20	(c) 21-50	(d) 51-100
1005-501-3198	LINK, BARREL:	5	2
1005-550-8694	MAGAZINE, CARTRIDGE :	1	2	2
1005-288-3565	SWAB, SMALL ARMS CLEANING :	1	2
1005-550-4036	BRUSH, CLEANING, SMALL ARMS :	10	2	2
1005-556-4102	ROD, CLEANING, SMALL ARMS :	1	2
5305-601-9023	SCREW, MACHINE :	20	2
5315-501-3199	PIN, STRAIGHT, HEADLESS :	10	2

Section V. REPAIR PARTS LIST

(1) Source, Maint. and Recov. Code			(2) Federal Stock No.	(3) Description		(4) Unit Of Meas	(5) Qty. Inc. In Unit	(6) 15-Day Organizational Maint. Allowance				(7) Illustration	
(A) Source	(B) Maint.	(C) Recov.		Reference Number & Mfr. Code	Usable on Code			(A) 1-5	(B) 6-20	(C) 21-50	(D) 51-100	(A) Figure No.	(B) Item No.
P	C		1005-550-8694	REPAIR PARTS FOR: PISTOL, CAL. .45, AUTOMATIC, M1911A1		EA	1	*	*	2	2	B-1	1
				MAGAZINE, CARTRIDGE: 5508694 (19205)									
P	O		5315-501-3199	PIN, STRAIGHT, HEADLESS: S, 0.1595 MAX DIA. 0.358 O/A LG (BARREL LINK) 5013199 (19205)		EA	1	*	*	*	2	B-1	8
P	O		1005-501-3198	LINK, BARREL: 5013198 (19205)		EA	1	*	*	*	2	B-1	9
P	O		1005-600-8599	PIN, FIRING: 6008599 (19205)		EA	1	*	*	*	*	B-1	11
P	O		1005-501-3204	SPRING, HELICAL, COMPRESSION: 40 COILS, FIRING PIN 5013204 (19205)		EA	1	*	*	*	*	B-1	12
P	O		1005-600-8602	SPRING, SEAR: 6008602 (19205)		EA	1	*	*	*	*	B-1	18
P	O		1005-600-8600	STRUT, HAMMER: 6008600 (19205)		EA	1	*	*	*	*	B-1	22
P	O		5305-601-9023	SCREW, MACHINE: FIL-HD, S, PHOS-CTD, 0.150-50NS, 0.260 O/A LG (GRIP) 6019023 (19205)		EA	4	*	*	*	2	B-1	26
P	O		1005-556-4063	GRIP, PISTOL: LH, PLASTIC, CHECKERED 5564063 (19205)		EA	1	*	*	*	*	B-1	27
P	O		1005-556-4062	GRIP, PISTOL: RH, PLASTIC, CHECKERED 5564062 (19205)		EA	1	*	*	*	*	B-1	28
P	O		1005-501-3194	SPRING, HELICAL, COMPRESSION: 14-1/2 COILS, PLUNGER 5013194 (19205)		EA	1	*	*	*	*	B-1	30

Section VI. SPECIAL TOOLS LIST

(1) Source, Maint. and Recov. Code			(2) Federal Stock No.	(3) Description Reference Number & Mfr. Code Usable on Code		(4) Unit Of Meas	(5) Qty. Inc. In Unit	(6) 15-Day Organizational Maint. Allowance				(7) Illustration	
(A) Source	(B) Maint.	(C) Recov.						(A) 1-5	(B) 6-20	(C) 21-50	(D) 51-100	(A) Figure No.	(B) Item No.
			1005-298-3565		TOOLS AND EQUIPMENT AUTHORIZED FOR UNIT REPLACEMENT SWAB, SMALL ARMS CLEANING: COTTON, 2-1/2 SQ. (1,000 per pg) 5019316 (19204)	PG	...	*	*	*	2		
			1005-550-4036		BRUSH, CLEANING, SMALL ARMS: M5 BORE 5504036 (19205)	EA	...	*	*	2	2	B-2	1
			1005-556-4102		ROD, CLEANING, SMALL ARMS: M4 5564102 (19205)	EA	...	*	*	*	2	B-2	2
			1095-592-6491		HOLSTER, PISTOL: HIP, M1916 (BLACK) 7791466 (19205)	EA	...	*	*	*	*	B-2	3
			1095-973-2353		HOLSTER, PISTOL: SHOULDER, M7, (BLACK) 7791527 (19205)	EA	...	*	*	*	*	B-2	4

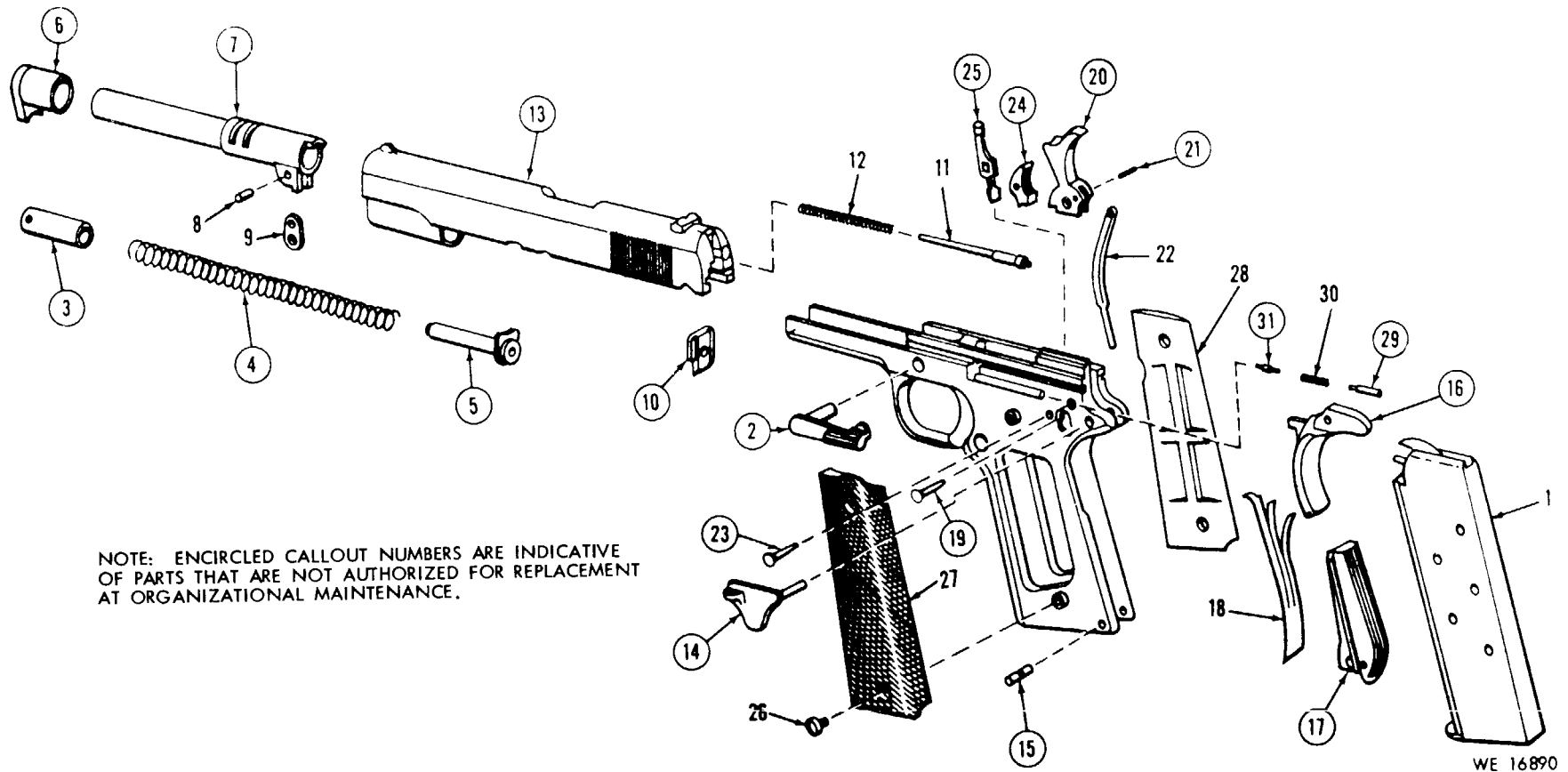
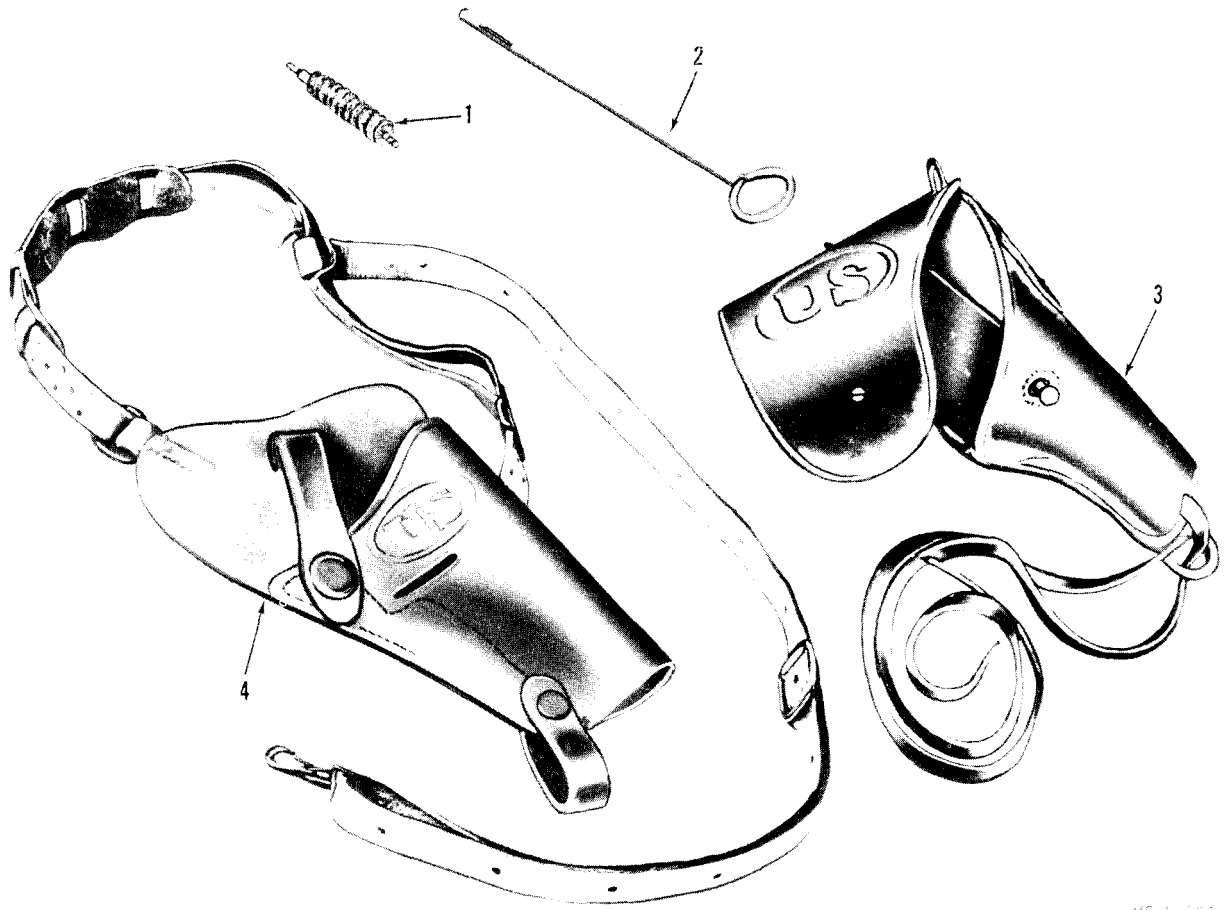

Figure B-1. Caliber .45, Automatic, Pistol, M1911A1—partial exploded view.



AF 16719

Figure B-2. Special tools and equipment.

Section VII. INDEX—FEDERAL STOCK NUMBER AND PART NUMBER

CROSS REFERENCE TO FIGURE AND ITEM NUMBER

<i>Stock Number</i>	<i>Figure No.</i>	<i>Item No.</i>	<i>Part No.</i>	<i>Mfg No.</i>	<i>Fig No</i>	<i>Item No.</i>
1005-501-3194	B-1	30	5013194	19205	B-1	30
1005-501-3198	B-1	9	5013198	19205	B-1	9
1005-501-3204	B-1	12	5013199	19205	B-1	8
1005-550-4036	B-2	1	5013204	19205	B-1	12
1005-550-8694	B-1	1	5504036	19205	B-2	1
1005-556-4062	B-1	28	5508694	19205	B-1	1
1005-556-4063	B-1	27	5564062	19205	B-1	28
1005-556-4102	B-2	2	5564063	19205	B-1	27
1005-600-8599	B-1	11	5564102	19205	B-2	2
1005-600-8600	B-1	22	6008599	19205	B-1	11
1005-600-8602	B-1	18	6008600	19205	B-1	22
1095-592-6491	B-2	3	6008602	19205	B-1	18
1095-973-2353	B-2	4	6019023	19205	B-1	26
5305-601-9023	B-1	26	7791466	19205	B-2	3
5315-501-3199	B-1	8	7791527	19205	B-2	4

APPENDIX C

MAINTENANCE ALLOCATION CHART

Section I. INTRODUCTION

C-1. General

The maintenance allocation chart indicates specific maintenance operations performed at proper maintenance levels. Deviation from maintenance operations allocated in the chart is authorized only upon approval of the Commanding Officer.

C-2. Maintenance Functions

The maintenance allocation chart designates overall responsibility for the maintenance function of an end item of assembly. Maintenance functions will be limited to and defined as follows:

INSPECT	To determine serviceability of an item by comparing its physical and mechanical characteristics with established standards.
TEST	To verify serviceability and to detect electrical or mechanical failure by use of test equipment.
SERVICE ADJUST	To clean, preserve and lubricate. To rectify to the extent necessary to bring into proper operating range.
ALIGN	To adjust specified variable elements of an item to bring to optimum performance.
CALIBRATE	To determine the corrections to be made in the readings of instruments or test equipment used in precise measurement. Consists of the comparison of two instruments, one of which is a certified, standard of known accuracy, to detect and adjust any discrepancy in the accuracy of the instrument being compared with the certified standard.
INSTALL	To eat up for use in an operational environment.
REPLACE	To replace unserviceable items with serviceable assemblies, subassemblies, or parts.
REPAIR	To restore an item to a serviceable condition. This includes, but is not limited to, inspection, cleaning, preserving, adjusting, replacing, welding, riveting, and strengthening.

OVERHAUL To restore an item to a completely serviceable condition by disassembling the item to determine the condition of each of its component parts and reassembling it using serviceable or new assemblies, subassemblies or parts.

REBUILD To restore an item to a standard as nearly as possible to original or new condition in appearance, performance, and life expectancy. This is accomplished through complete disassembly of the item, inspection of all parts or components, repair or replacement of worn or unserviceable elements (items) using original manufacturing tolerances and specifications, and subsequent reassembly of the item.

C-3. Explanation of Format

Purpose and use of the format are as follows:

a. *Column a, Group Number.* Lists group numbers, to identify components and assemblies.

b. *Column b, Component Assembly Nomenclature.* Lists the noun names of groups and assemblies on which maintenance is authorized.

c. *Column c, Maintenance Functions.* Lists the various categories of maintenance to be performed on the weapon.

d. *Use of Codes.* Explanation of the use of codes in maintenance function, column c, is as follows :

<i>Code</i>	<i>Explanation</i>
c	Operator/Crew
o	Organizational Maintenance
F	Direct Support Maintenance
H	General Support Maintenance
D	Depot Maintenance

e. *Column d, Tools and Equipment.* This column will be used to specify those tools and test equipment required to perform the designated function.

f. *Column e, Remarks.* Self-explanatory.

Note. Columns not utilized are considered not applicable.

By Order of the Secretary of the Army:

W.C. WESTMORELAND,
General, United States Army,
Chief of Staff.

Official :

KENNETH G. WICKHAM,
Major General, United States Army,
The Adjutant General.

DISTRIBUTION :

To be distributed in accordance with DA Form 12-40 (qty rqr Block #116) requirements for Organizational maintenance, Pistol, Cal. .45, Automatic M1911A1.

This fine document...

Was brought to you by me:



[Liberated Manuals -- free army and government manuals](#)

Why do I do it? I am tired of sleazy CD-ROM sellers, who take publicly available information, slap “watermarks” and other junk on it, and sell it. Those masters of search engine manipulation make sure that their sites that sell free information, come up first in search engines. They did not create it... They did not even scan it... Why should they get your money? Why are not letting you give those free manuals to your friends?

I am setting this document FREE. This document was made by the US Government and is NOT protected by Copyright. Feel free to share, republish, sell and so on.

I am not asking you for donations, fees or handouts. If you can, please provide a link to liberatedmanuals.com, so that free manuals come up first in search engines:

<A HREF=<http://www.liberatedmanuals.com/>>Free Military and Government Manuals

– Sincerely
Igor Chudov
<http://igor.chudov.com/>