

Historic, archived document

Do not assume content reflects current scientific knowledge, policies, or practices.

1
Ag 847
#2090
Rev 1962

LOGGING FARM WOOD CROPS

Revises and Supersedes
Farmer's Bulletin 2008
Supersedes Farmer's Bul. 1907

LIBRARY
RECEIVED
JAN 10 1963
U. S. DEPARTMENT OF AGRICULTURE
BELTSVILLE, MARYLAND



Farmers' Bulletin No. 2090
U. S. DEPARTMENT OF AGRICULTURE

ACKNOWLEDGMENTS

This revised bulletin, designed to have nationwide application, was prepared with the specific suggestions and help of more than 80 qualified people throughout the country. The author wishes especially to acknowledge the advice of those listed here.

John W. Allen, Bloedel Timberlands Co.; George J. Carr, Pacific Car & Foundry Co.; A. Koroleff, Pulp & Paper Research Institute of Canada; David W. Sowers, Jr., West Virginia Pulp & Paper Co.

Kenneth C. Compton, University of the State of New York; Leland W. Hooker, Michigan State College of Mining and Technology; Myron Krueger, University of California; J. W. Miller, Jr., University of Florida; O. M. Patten, Montana State University; T. D. Stevens, Michigan State

University; A. E. Wackerman, Duke University; E. B. Moore, New Jersey Department of Conservation and Economic Development.

The following members of State extension services: Lewis P. Bissell, Maine; John L. Gray, North Carolina; G. B. Shivery, Tennessee; C. W. Simmons, Texas; F. B. Trenk, Wisconsin; Fred E. Winch, Jr., New York.

The following members of the Forest Service, United States Department of Agriculture: Ralph K. Day, Central States Forest Experiment Station; E. E. Matson, Pacific Northwest Forest Experiment Station; Walton R. Smith, Southeastern Forest Experiment Station; and R. D. Carpenter, a former member of the Southern Forest Experiment Station.

This publication is a revision of and supersedes Farmers' Bulletin 2008, Logging Farm Forest Crops in the Northeast. It also supersedes Farmers' Bulletin 1907, Equipment and Methods for Harvesting Farm Woodland Products.

Washington, D.C.

Revised December 1962

CONTENTS

	Page		Page
Farm equipment useful for logging	2	Specialized logging equipment—Continued	
The wheel tractor	2	Getting special equipment on contract	29
The crawler tractor	4	Layout of the logging job	29
Horses and mules	4	Logging roads	30
The farm truck	5	Skid trails	30
Handtools	5	Landings	32
The ax	5	Skidways	33
Handsaws	9	Marking and marketing	34
Wedges	11	Felling	35
Peavies, cant hooks, and pulp hooks	13	Limbing	38
Peeling tools	15	Bucking	39
Hard hats and safety shoes	18	Choice of location	39
Specialized logging equipment	18	Small trees	39
Power chain saws	18	Large trees	40
Sharpening the saw chain	19	Use of power saws	42
Using a chain saw	21	Skidding	43
Wheel circular saws	23	Skidding with horses	43
Other types of power saws	23	Skidding with tractors	45
Antifriction devices for skidding	23	Loading	48
Other specialized devices	26	Loading small wood by hand	48
Buzz saw	26	Loading small wood by machine	48
Wood splitter	27	Loading logs and poles by hand	48
Conveyor loader	27	Log-loading devices	49
Small sawmills	27	Hauling	51
Portable chipper	28	Supplementary motion pictures	52

LOGGING FARM WOOD CROPS

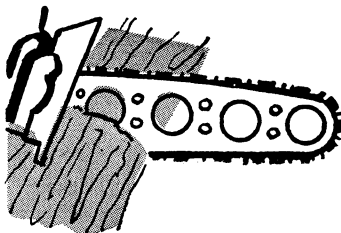

By Fred C. Simmons

Logging Specialist, Northeastern Forest Experiment Station, Forest Service

Farm woodlands make up about 40 percent of the timbered area of the United States. On an average farm or ranch, woodlands may include 60 percent or more of the area. Yet on most farms or ranches the woodlands do not contribute their fair share of the annual income.

Since the farmer generally lets somebody else do the logging in his woods, this lack of return comes about for two main reasons. First, he loses about two-thirds of the income he could have got from his trees. He follows this system for practically no other crop. His corn is not sold standing in the field, nor his potatoes in the ground.

Second, by this method the farmer usually has little control over the cutting done on his woodland. At long intervals, when he needs money, the average farmer sells his standing timber for a lump sum, and lets the buyer cut it as he pleases. Often the buyer clear cuts the woods; he cuts immature timber as well as mature—and destroys the reproduction as he logs. Often a fire burns through the cutover area. All this so reduces the quality and quantity of growing stock that the farm woodlands are producing only a small fraction of the volume and value yield of which they are capable.

This bulletin was planned to tell you how *you* can harvest *your* timber crops with the equipment *you* already have or can easily get.

Generally, by doing your own logging and delivering the products to the mill or railroad siding you will get two or three times as much money as you would by selling your timber as it stands in the woods. Also there are other advantages. Logging (and some simple processing) is a good way and a profitable way to use your own time, to keep your hired help busy, and to use idle equipment when other work on the farm is slack. As by-products of logging you can get wood products needed on the farm—material like fuelwood, fence posts, and poles.

These products for home use—and some for sale—often come from stand-improvement cuttings. You can make such cuttings every year. They will not only produce useful material but will also improve the growth of the trees left. Both the harvest cuttings and the improvement operations, if they are done properly, will reduce hazards from fire, insects, disease, and windthrow.

Methods of forest management will be discussed only incidentally in this bulletin. There are already many good publications on that subject.¹ Advice and help in management and marketing are also available from

¹ Publications include the following:

Managing Small Woodlands. By A. Koroleff and J. A. Fitzwater. 72 pp., illus. Amer. Forestry Assoc. Washington, D.C. 1947.

Managing the Family Forest. U. S. Dept. Agr. Farmers' Bul. 2187. 61 pp., illus. Washington, D.C. 1962.

State extension services and State forestry departments.

Before undertaking a logging job, ask about the local laws that may affect you. For example, in some Western States a special license from the public utilities commission is necessary before you can haul forest products on the public highways with your truck, even though the products come off your own land. In most Eastern States there is no such requirement.

In most States when a farmer logs on his own land, he is subject to the same rules concerning social security payments and workmen's compensation as those that apply to his regular farmwork. As this is not true everywhere, ask about it. The county forester, county agent, or State forester should be able to advise you. Also, before logging make sure exactly where your property lines are, lest you trespass on your neighbor's land.

FARM EQUIPMENT USEFUL FOR LOGGING

Much of the equipment used on the farm can also be used for logging, especially with the help of inexpensive accessories that have been developed recently.

The Wheel Tractor

The wheel tractor (fig. 1) can be most useful for logging on the more level, open woodlands. Of course, some kinds of tractors are more useful in the woods than others. A tractor with a high center of gravity is dangerous to use even on moderate slopes. A tractor with small front wheels will have difficulty going over obstacles, such as down timber and hummocks; and the smaller tires are apt to blow out. But some of the most popular makes of farm tractors have fairly



M83049F

Figure 1.—An ordinary farm tractor can be used on many logging jobs. Note how the hydraulic-lift drawbar is used in skidding the log. (Slope in the background of this area is hazardous for the use of a wheel tractor.)

large front wheels and low centers of gravity; they can be used safely even on rather steep and rough terrain. Of course, tractors should be driven with extreme care under all unusual operating conditions. It is dangerous to hitch a load to the rear axle of a tractor, or to any point higher than the normal drawbar level.

A winch, mounted on the rear, adds enormously to the usefulness of a tractor as a logging machine. With a winch you can drag logs out of rough, rocky, or boggy places where it would be unwise to take the machine. A tractor can exert 50 to 80 percent more power from a winch than it can at the drawbar.

The hydraulic-lift drawbar, with which so many farm tractors are now equipped, is also useful in logging. In skidding logs, this device makes it possible to reduce drag by lifting the front ends of the logs off the ground so as to prevent their digging in. This use of the lift drawbar makes it possible to skid up to half again as much volume as the tractor could pull without it.

Crawler tracks of rubber or steel have recently been made available for mounting on several makes of wheel tractors (fig. 2). These call for a set of auxiliary bogie wheels, mounted in front of the rear wheels of the tractor. A crawler track is fitted around each rear wheel and its bogie, and a wheel tractor so fitted has much better traction in mud or snow. Many farmers in northern sections attach this accessory to make their wheel tractors more useful during the winter months for plowing snow out of their driveways and for handling barn refuse.

Another tractor accessory that can be used for logging is the hydraulic-lift manure fork. It can be used for loading logs and bolts onto a wagon or truck.

But even with these accessories, the 25- to 30-horsepower wheel tractor normally used on farms is limited to



F-477910

Figure 2.—Accessory crawler tracks on a wheel tractor give much better traction in mud or snow.

handling small timber or short logs from the bigger trees. Even with the best conditions, such a tractor can hardly be expected to handle a log scaling more than 300 board-feet, or pole wood scaling more than about half a cord. A 300-board-foot log is about a 16-foot log, 20 inches in diameter at the small end, or a tree length from an 18-inch tree. Half a cord of tree-length poles would be about three sticks, 10 inches in butt diameter and 40 feet long.

The new 4-wheel-drive, rubber-tired tractors are better suited than the 2-wheel for logging, particularly in rough country. A typical tractor of the 4-wheel-drive type weighs about 6,000 pounds and has about 40 drawbar horsepower (fig. 3). Engine and operator's controls are moved ahead over the front wheels, and an integral logging arch and winch are installed over the back wheels. Consequently, when unloaded, about 70 percent of the weight of the



Figure 3.—One of the new 4-wheel-drive tractors, equipped with a winch and integral arch for logging. With the winch logs can be dragged out of places where a tractor cannot be taken.

machine is on the front wheels, and only 30 percent is on the rear wheels. When the front ends of a load of logs (600 to 800 board feet) are pulled up into the arch, the weight on the tires is increased to about 11,000 pounds, and approximately equal weight is distributed on both the front and back wheels. This increases the tractive ability of the machine enormously. Steering of these small, wheeled, skidding tractors is accomplished by means of a knuckle in the frame between the front and rear wheel bogies, and opposed hydraulic cylinders on each side of this knuckle. Consequently, maneuverability of these machines is excellent. One recent model has a turning radius of 39 inches on the inside tires.

The Crawler Tractor

The farmer who expects to spend part of his work-year on woods jobs should consider using one of the small-

er crawler tractors (fig. 4) as a dual-purpose machine, for use both in the woods and in the fields. The smallest diesel-engine tractors now available have about 30 drawbar horsepower and weigh about 3 tons. Small gasoline-powered crawler tractors are available in 20- and even 12-horsepower sizes; they weigh about 3,000 and 1,500 pounds respectively.

The crawler tractor does not compact the soil in plowed fields so much as do the wheel tractor or horses, and on many types of footing it has greater pulling power.

The main disadvantages of the crawler tractor are that it does not have as much speed as a wheel tractor; it cannot be driven on paved highways; and the track requires special maintenance, as does the diesel engine.

If you plan to operate any kind of tractor in timber where there is danger from falling trees or branches, put a protective canopy on the tractor. Make it with pipes or bar steel and sheet metal for an overhead covering. It may save your life.

Horses and Mules

The use of horses and mules in the woods is decreasing, as it is on farms generally. Yet many farm horses are used for woods work part of the year, especially in northern parts of the country and in the southern mountains (fig. 5).

Some people prefer horses to tractors for skidding timber in selectively cut young stands because they think less damage is done to the trees left for future growth. However, damage results only when the tractor is operated carelessly. Horses can work in rocky and steep areas on high mountain slopes where the use of a tractor might be unsafe or inefficient.



F-381593

Figure 4.—The small crawler tractors can be used as dual-purpose machines, for farm work as well as logging.



F-448780

Figure 5.—Farm horses are still used for logging in many parts of the country.

In lowlands of the South, and especially in swamps, mules are used more than horses. Mules can stand hot weather better, and they are generally less excitable.

Oxen were once a major source of motive power in the woods. Still used in some localities, they are especially useful in soft and swampy lands.

The use of animals in skidding is most economical when the skidding

is limited to light loads and short distances. For skidding less than 200 yards, horses can often bring out small logs more cheaply than tractors—because of their greater maneuverability and lower capital cost. But for longer skids and heavy loads, tractors are more economical.

The Farm Truck

Most farmers have either a flat-bed truck or rubber-tired farm wagons that can be towed behind a wheel tractor. They can be used for hauling logs or other logging products to a nearby mill or railroad siding. Simple methods of loading and hauling will be described later.

Of course, many farmers sell the products of their logging operations at the roadside. This relieves them of loading and hauling, which are difficult and often dangerous jobs, and may require special equipment.

HANDTOOLS

Many of the handtools that the logger uses are also used on the farm. Most farmers have an ax, some wedges, a crosscut saw, and perhaps a bucksaw around the place for working up fuelwood and for rough construction jobs. Some of the logger's tricks in selecting, caring for, and using these tools can make his logging work easier and safer.

The Ax

Even though loggers are adopting mechanized equipment faster than ever before, the ax is still a basic logging tool. It is used for clearing slash and brush to make space to work in safely, it is used in felling for cutting out the notch, and it is the best tool for most limbing. Small saplings and poles can be cut faster and more easily with the ax than with any other tool.

Yet the art of axmanship is fast becoming lost in many sections of the country, not only on farms but also on commercial logging jobs. Often axes are not well maintained and used. This makes the work unnecessarily hard, and it causes accidents.

There are many different patterns and weights of axes (fig. 6). Choosing among them is largely a matter of individual preference. Totally different types of axes are used in various sections of the country with equal success for exactly the same type of cutting. In general, lighter axes with short handles are more useful for cutting small timbers and saplings, and for limbing where space is limited.

The double-bit ax is usually the choice of the professional woodsman in the North, and in the mountains of the South. One bit is kept thin and

razor sharp for chopping in clear wood; the other is kept somewhat thicker, but still sharp, for work around knots or in places where the ax might strike the ground.

The single-bit ax (poll ax), which is more commonly used in the southern lowlands and on farms, is a safer and generally more useful tool. The poll can be used for driving stakes and wooden wedges. The blade can be stuck in a log or stump without leaving a cutting edge exposed to injure someone who might stumble on it.

Despite differences in pattern and size, the ax must have a well-balanced head of high-quality, well-tempered steel, and a strong, smooth, and well-fitted handle. The top-grade axes of all the better manufacturers meet these requirements.

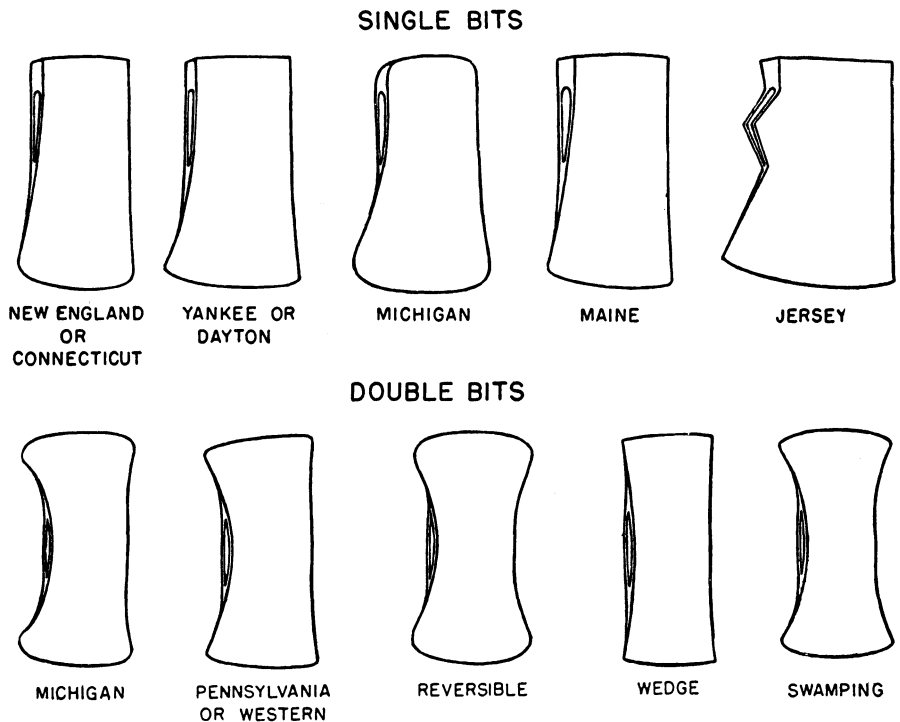
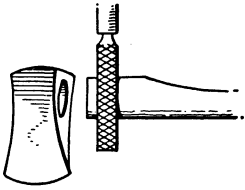

Figure 6.—Some of the many different ax patterns.



FIT TO EYE WITH DRAW SHAVE
AND WOOD RASP



ASSEMBLE AND TEST FOR
ALINEMENT AND "HANG"

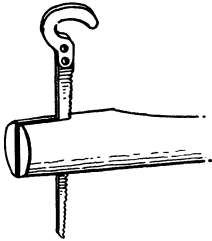

TAKE APART AND MAKE WEDGE
SLIT WITH THIN BLADE SAW

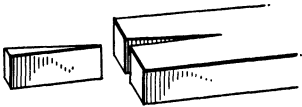

SAW OR SHAPE WEDGE FROM
DRY, STRAIGHT-GRAINED
HARDWOOD

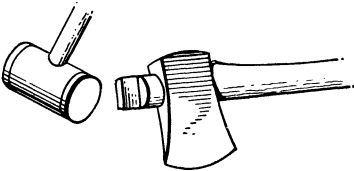

ASSEMBLE AND DRIVE IN
WEDGE (USE WOODEN MALLET)

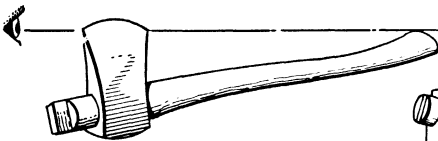

TEST FOR ALINEMENT
AND
HANG

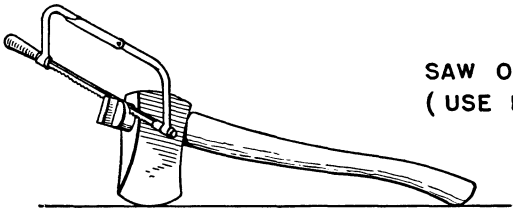

SAW OFF EXCESS
(USE HACKSAW)

Figure 7.—Steps in fitting a handle to an ax.

In choosing an ax it makes little difference whether the head is of one piece of steel, with the cutting edge specially tempered, or of two, with a special tool-steel edge welded onto a softer body. Reliable ax manufacturers can make a good ax either way. But "seconds," often manufactured under a different brand name, are apt to have a defective weld or uneven temper or some other flaw.

In fitting a handle to an ax (fig. 7), be sure that the handle and the wooden wedge you use are dry. Then if they swell a little in use, the head will stay tight. The use of steel wedges is not recommended, because they may compress the wood in the end of the handle so much that it loses its ability to spring back.

Hickory is the favorite wood for ax handles. It makes little difference whether the hickory used is red or white. The wood in the handle should be of relatively rapid growth and free from pin knots, bird pecks, or other defects. Beware of handles that have been covered with paint or enamel. It may conceal defects.

Most axes, as they come from the manufacturer, have a blade too thick for efficient chopping. You should thin the blade for an inch or so back from the cutting edge. Use a sharp mill file, or—better—a wet, slowly turning grindstone (fig. 8). A coarse file leaves the surface too rough. Never use an emery wheel; it is apt to

draw the temper of the blade. After sharpening, and at intervals during use, the ax bit should be honed with a whetstone to a smooth, keen edge.

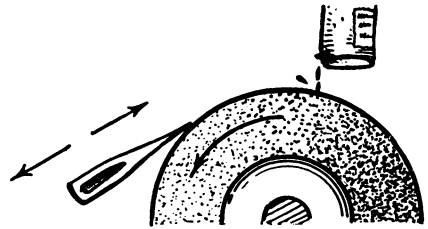

Figure 8.—A wet grindstone, turning slowly, is best for sharpening an ax: Move ax back and forth while grinding. Never use an emery wheel.

Ax gages have been devised to test the taper for various kinds of chopping. Figure 9 shows two satisfactory gages in actual size, so you can make copies from light sheet steel or brass.

For all those who play games calling for a free and easy swing with a bat or club chopping is an art easily learned. It is important to have an easy and relaxed stance and to have accuracy in each blow (fig. 10). It is not necessary to hit hard. Accuracy is more important than power.

It is good to learn to chop both right-handed and left-handed. This ability will make it possible to use an ax safely and efficiently in places where chopping only from one side would be troublesome and dangerous.

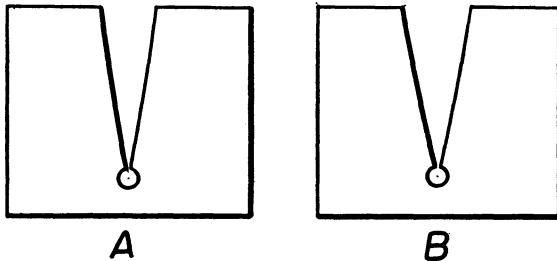

Figure 9.—Gages for testing the taper of the ax edge: A, For a 2½-pound ax used on softwoods; B, for a 3½-pound ax used on hardwoods.

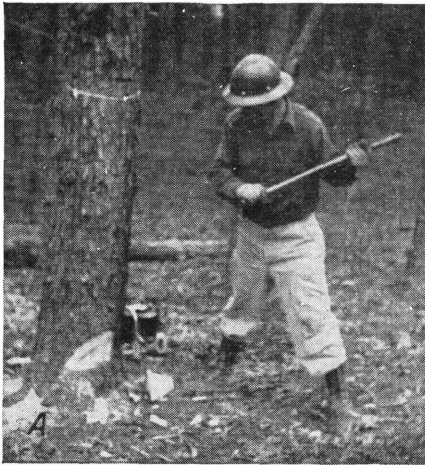

Figure 10.—Stance for chopping: *A*, Top of ax stroke. Notice the position of the hands. *B*, End of ax stroke. The upper hand slides down the handle during the swing.

In cutting small brush and saplings, hold the stem with one hand, hold the ax choked in the other, and slice through the wood. A large sapling is most easily cut by bending it over with one hand, then cutting the strained fibers on the upper side. Be sure your feet are clear of the ax swing.

The ax is a dangerous tool wherever it is used. Many accidents are caused by its misuse. Safe work habits can

reduce these accidents. The safest way to carry an unsheathed ax is at the side of the body that is downhill; grip the ax at the point of balance near the head, cutting edge down. If you stumble or slip, you can easily toss the ax aside as you fall.

When not in use, the ax should be placed where other workers are not liable to stumble over it. A simple leather sheath or wooden box should be used to cover the head of the ax when it is transported in a vehicle or is carried by hand for long distances. This will protect the keen edge of the blade, as well as the people who might come in contact with it.

Handsaws

The crosscut saw and even the Swedish bow saw are rapidly being replaced on woods jobs by the gasoline-powered chain saw. Nevertheless the handsaws are still useful woods tools, particularly on small jobs such as a farmer might have.

The crosscut saw is the better tool for cutting large trees by hand. It comes in straight-backed and sway-backed models (fig. 11). In the East, use of the sway-backed saw is limited to felling and bucking small timber, such as that cut for mine props, poles and piling, and pulpwood. A wedge can be inserted behind a sway-backed saw sooner than behind a straight-backed saw. In the West, sway-backed saws are ordinarily used for felling, and the stiffer, straight-backed saws in big timber.

Within its cutting capacity (about 9 inches), the Swedish bow saw (fig.



Figure 11.—Crosscut saw patterns: *A*, Sway back; *B*, straight back.

12) is undoubtedly the most efficient handtool for sawing wood. It cuts about as fast as a two-man crosscut saw; and the narrow, tapered blade is rarely pinched, even in bucking felled trees that are suspended from both ends. In addition, you can carry extra blades into the woods with you; and if a blade becomes dull, loses its set, or breaks, you can easily replace it.

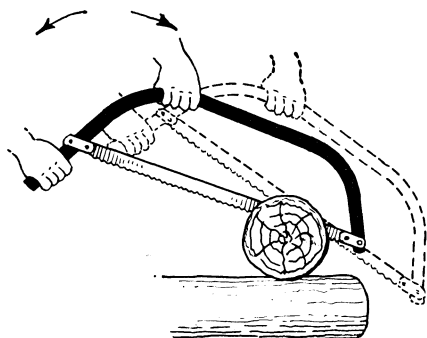

Figure 12.—The bow saw cuts fast. A rocking stroke is used so that the saw is always cutting on a corner.

Both crosscut and bow saws are available in three general tooth patterns (fig. 13). The four-teeth-and-a-raker pattern is most popular for cutting softwoods. The four slim,

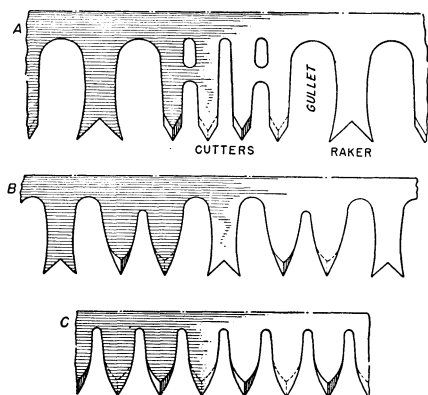

Figure 13.—Common tooth patterns: A, For softwoods; B, for hardwoods; C, for dry wood only.

sharp-pointed teeth, set alternately to the right and left, cut out the sides of the kerf. Then the raker acting like a tiny carpenter's plane, takes a shaving from the bottom of the cut, and curls it up in the gullet.

The two-teeth-and-a-raker patterns are more often used in cutting hardwoods. The rakers do not have to take so thick a shaving from the bottom of the cut. The all-cutting-teeth-no-raker patterns are most frequently used in cutting dry wood in which the sawdust crumbles readily.

Detailed instructions for sharpening and setting both crosscut and bow-saw blades are available in illustrated booklets available free from the manufacturers. Local hardware dealers frequently have such booklets available for free distribution. The tools you need for this operation are simple and inexpensive; and although it takes patience, the art of filing a saw correctly is not hard to learn.

The sawing technique varies somewhat with the two types of saws. The crosscut saw is pulled straight back and forth into the cut. The belly in the blade makes it bite into the wood. When two men are working with a crosscut saw, the sawyer who has just pulled his end lets his hands ride back easily. He does not push, lest the saw buckle and jam. On each stroke the blade is pulled its entire length so that the accumulated shavings drop from the raker gullets. It is important to keep the saw going straight. A curved or crooked cut makes for hard work.

The bow saw is rocked 2 or 3 inches between each forward and backward stroke so that it is always cutting on a corner. In bucking, the handle end is raised during each forward stroke, and on the backward stroke it is lowered. This shift in position reduces the tendency of the saw to chatter and makes for faster cutting.

In sawing pitchy woods like pine, Douglas-fir, or spruce (with either a

crosscut or a bow saw) pitch will accumulate on the blade and make the saw hard to use. Frequent applications of kerosene on the blade dissolve the pitch. An aluminum Army canteen with its belt loop (available at a surplus store) is handy for carrying kerosene in the woods. For easy sprinkling, drill a couple of small holes in the cap or use a cork stopper with a groove sliced down each side. The metal canteen is much safer to carry than a pint bottle of kerosene. A glass bottle left in the woods can act as a lens when the sun's rays shine through it—it can start a fire.

Both the bow saw and the crosscut saw are sharp-pointed tools, and they can make serious wounds. The blades should be handled carefully. When transported in a motor vehicle, they should be placed in a rack or in a plywood guard. When carried in the woods, the teeth should be pointed away from the body. The crosscut is best carried across the shoulder with the teeth pointing away from the neck; the back handle should be removed to prevent its catching on anything. The bow-saw frame can be hung over the shoulder, with the toothed edge of the blade facing back.

Special care should be taken by everyone working in the woods to

see that other people are not injured. A man carrying a crosscut saw across his shoulder should not turn unless he is sure that no one is within sweep of the blade. In walking single file in the woods, the man carrying the crosscut should be in the rear. When inserting a new blade in a bow saw, make sure that no one is in front of it as the blade may suddenly snap loose.

Wedges

Wedges are indispensable in woods work. A wedge driven into a cut behind the saw prevents pinching. In felling, wedges are used to tip the tree in the direction desired. Wedges are also used in splitting wood.

Wooden wedges (fig. 14) are frequently used by felling and bucking crews—particularly those working in softwoods. Wooden wedges are cheap. Often they can be made by hand from material available in the woods. Almost any hardwood makes a good wedge. The best ones are made from hard, close-grained species like dogwood, ironwood, hard maple, hickory, persimmon, and beech. Wedges made of green wood do not stand up very well. Generally a sawed wedge is better than one cut out with an ax. The roughened sur-

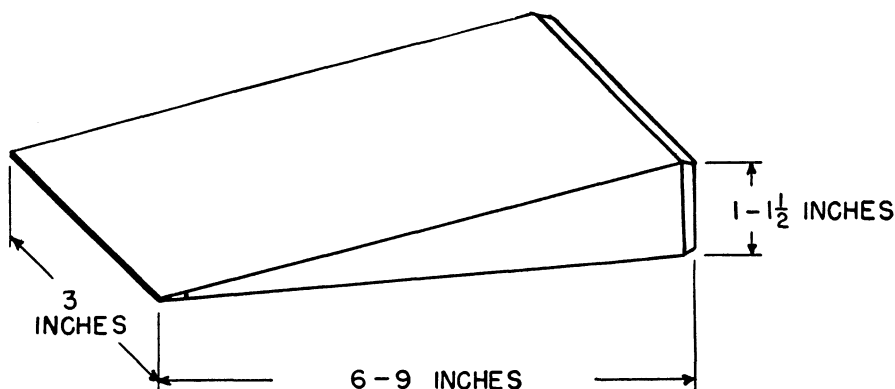

Figure 14.—Dimensions for a wooden wedge. Hard, close-grained species make the best wedges.

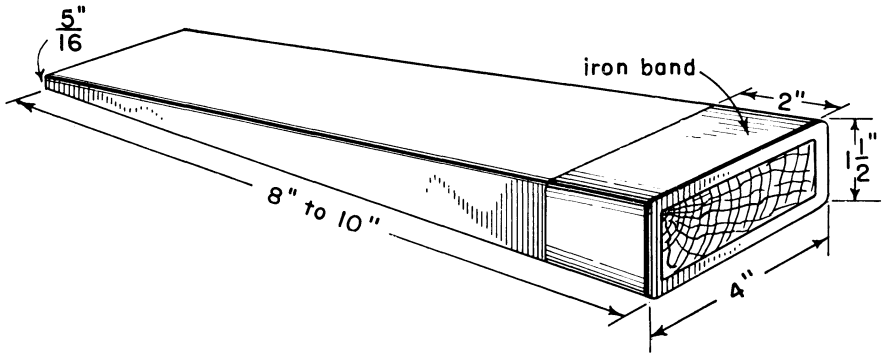

Figure 15.—A wooden wedge for use with a chain saw. Aluminum and magnesium wedges are also used with chain saws.

face left by the saw holds better in the cut, and the taper is likely to be more even. The advantage of the wooden wedge is that it can be driven safely with the poll of a single-bit ax.

Wooden wedges are also used with chain saws (fig. 15). Since the wedge is apt to come into contact with the moving chain on the back side of the blade, you should not use a steel wedge with a chain saw; it could ruin the chain. Wedges designed especially for use with chain saws are also made of aluminum and magnesium. The entering edge of the chain-saw wedge should be about one-fourth inch thick so that it can engage the sides of the wide kerf at once.

In felling and bucking a good many wooden wedges may be split or crushed by a woods crew in the course of a day; so many fellers, especially those working with crosscut saws in hardwoods, use steel wedges (fig. 16). Many types of steel wedges are on the market, and many are made by local blacksmiths or in the farm forge. It is important that the steel wedge be

left untempered. Otherwise, when hit with a tempered steel sledge it is apt to spall, and a flying fragment could easily destroy the sight of an eye.

A smooth-sided steel wedge is likely to kick back out of a cut. Consequently, the faces of many commercially made steel wedges are creased, and those of many homemade wedges are roughened with a cold chisel.

In time the head of a steel wedge may become mushroomed by pounding. Wedges in this condition should not be used; the danger of flying fragments from the mushroomed edges is too great. But you can easily put such a wedge in shape for use by grinding off the mushroomed edges on an emery wheel.

Splitting wedges are ordinarily longer and thicker in the shank than felling and bucking wedges (fig. 17). Some are shaped like a big cold chisel, others like an elongated single-bit axhead. There is also available a splitting maul, which has a hammer face on one end and a wedge on the other. This maul is frequently used in splitting fuelwood.

Explosive wedges (fig. 18) have not long been used in the woods. For years some loggers have been splitting tough wood with black powder by boring holes along the line to be



Figure 16.—Steel wedges: A, For felling; B, for bucking.

split, tamping in charges of powder, and setting off the powder. The explosive wedge simplifies the job, particularly with short bolts of wood.

The most popular pattern is a steel cylinder with a hole in the tapered end and a fuse hole along the side. About a tablespoonful of black powder is placed in the end hole, topped by dry wadding; then the wedge is driven into a sound place in the end of the bolt. The wood fibers that penetrate the hole tamp the load tight. A fuse, or preferably a miner's safety squib, is placed in the fuse hole at the side. It is good practice to lean a heavy bolt of wood against the driven end of the wedge to prevent its kicking back and becoming lost or possibly injuring someone. The fuse or squib is lighted and the woods workers seek shelter, preferably at about a 45° angle from the end of the bolt being split. The squib lets out a puff of smoke just before it sets off the charge. Even the toughest woods to split, like sycamore, blackgum, and elm, can be blown apart by this tool, although there is little control of the direction of splitting. Recently some explosive wedges have been made with square holes in the end; these have a slight directional control.

Black powder should be kept at a safe distance from flame or sparks, to avoid the danger of accidental fire or explosion. It is a good idea to use a

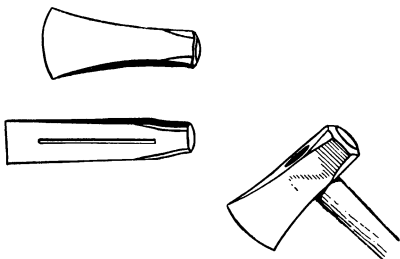

Figure 17.—Splitting wedges are longer and thicker than felling and bucking wedges: *Left*, two types of splitting wedges; *right*, a woodchopper's maul.

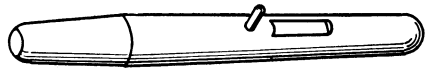

Figure 18.—An explosive wedge. These are helpful in splitting tough wood.

wooden spoon or paddle to pry off the lid of the powder can and to ladle out the powder. If these precautions are taken, there is no danger of sparks.

Peavies, Cant Hooks, and Pulp Hooks

The peavy (fig. 19) is another useful tool for the logger. It is merely a heavy hardwood handle, shod at the lower end with a steel ferrule ending in a spike, and having a dog hinged on one side. With this tool the logger can roll heavy logs, because the handle gives him good leverage. He can also use the peavy as a pry pole.

Fellers and buckers working in heavy hardwoods use a peavy to roll lodged trees loose, and as a pry pole to lift logs to avoid pinching the saw when the men are bucking. Peavies are often used to roll logs around to make the ends visible for scaling (fig. 20). Peavies are even more useful for getting logs clear of obstructions in skidding, for arranging them on a deck or landing, and for rolling them onto a truck.

A cant hook (fig. 19) is like a peavy except that the foot end of the handle is shod with a flat toe or bill facing the dog. Cant hooks are used somewhat the same as peavies, but they are used more at mills and landings than in the woods. The spike on the peavy makes it a more useful tool in the woods.

A cant hook can be made into a log jack (fig. 21). This change is made by welding or riveting a steel support onto the ferrule that the dog is hinged to, on the side opposite the dog. Small logs can be rolled over so that they rest on this support; this raises them off the ground for bucking,

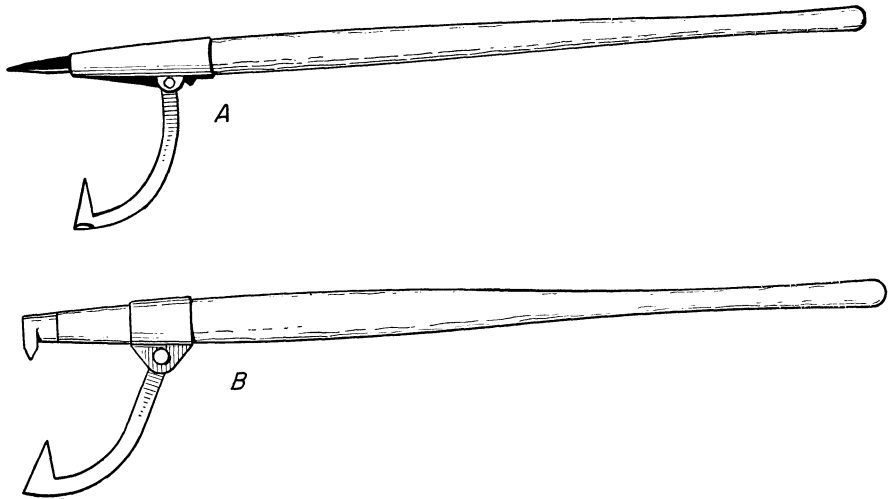

Figure 19.—A, The peavy; B, the cant hook. The peavy has a sharp spike on the end; the cant hook has a blunt nose.

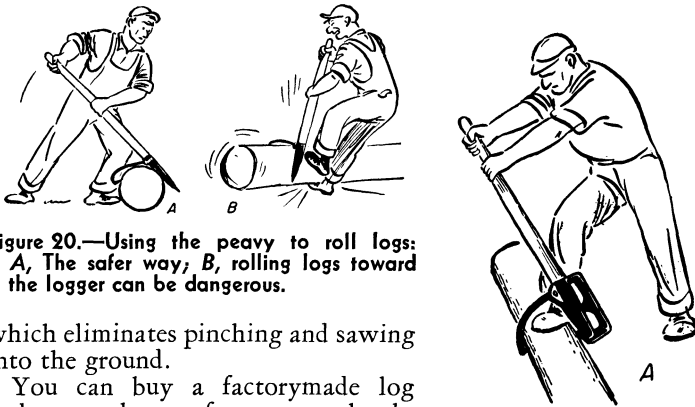

Figure 20.—Using the peavy to roll logs: A, The safer way; B, rolling logs toward the logger can be dangerous.

which eliminates pinching and sawing into the ground.

You can buy a factory-made log jack, or make one from a cant hook. Some farmers have made a log jack merely by bolting a block of wood to the ferrule opposite the dog.

For handling short bolts of wood you can use a pulp hook (fig. 22). This hook is like a dunnage or bale hook, but much stronger. Although the pulp hook is a simple tool it is important that it be manufactured correctly. A number of different patterns are made to suit individual preferences. For use in the North, the steel point should be tempered carefully, so that it is neither hard enough

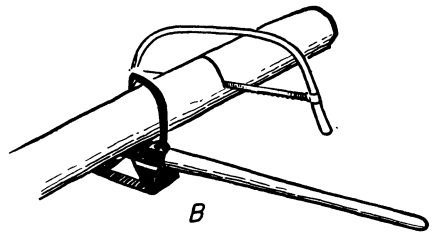

Figure 21.—A cant hook made into a log jack: A, Use of the log jack to roll a log over; B, log jack used as a support for sawing.

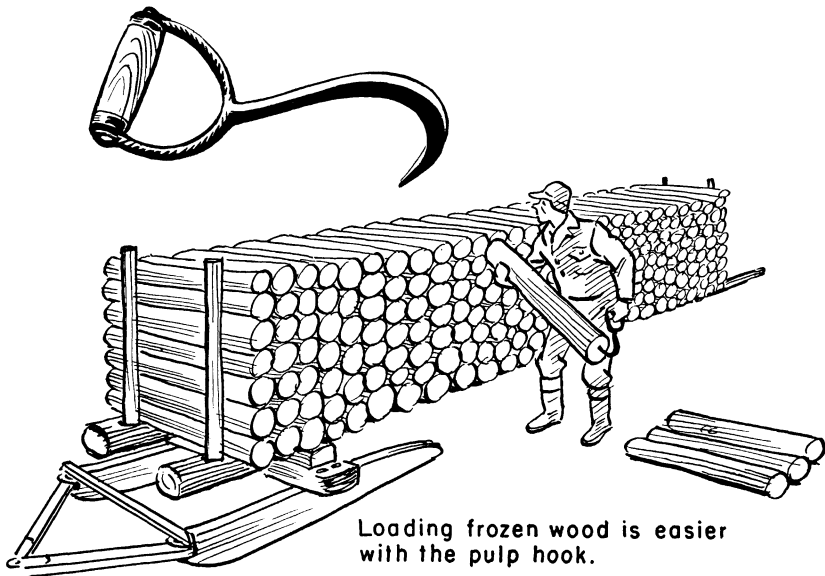

Figure 22.—The pulp hook.

to shatter nor soft enough to broom out when it hits hard, frozen wood. A square- or oblong-shaped point, with the tip flattened, is preferable to a round one, because it will cut the wood fibers rather than push them apart. The handle should be oval shaped for a firm grip, and attached firmly to avoid turning.

To use the pulp hook in the safest way drive it into the end of a stick; however, you may hook it into the side. The pulp hook is especially good for breaking ice-covered wood loose from a pile. Once you get used to working with a pulp hook, you can handle pulpwood or other short bolts with much greater ease and efficiency than you could with your hands alone. If you use the hook as an extension of your arm, you do not have to bend your back so much.

Peeling Tools

Peeled wood is very much in demand. It dries faster, deteriorates less in storage, and is cheaper to haul

than rough wood. Some pulp companies pay a premium of \$4 to \$5 a cord for it.

However, this premium price is not all clear gain, because 10 to 15 percent of the cord volume of rough wood is bark. If rough wood is worth \$15 a cord and peeled wood \$19, and the species being cut runs 15 percent bark, a cord of rough wood will make only eighty-five one-hundredths of a cord of peeled wood—worth \$16.15. Only \$1.15 is left to cover the cost of peeling. If a thinner barked species is being cut, of which only 10 percent of the volume is bark, then a cord of rough wood will make nine-tenths of a cord of peeled wood—worth \$17.10. The peeler gets \$2.10 a cord for his work.

The easiest time to peel wood is in the spring and early summer when the bark will "slip." The tool commonly used for this work is the spud (fig. 23). Essentially the spud is a slightly curved piece of flat steel, about 1½ inches wide, with a sharpened curved point and a handle.

Many patterns of spuds are on the market, and many are homemade from old automobile springs and straightened garden hoes.

For thin-barked species like spruce, aspen, and fir, in small sizes, spuds only 10 to 12 inches long are often used. For heavier barked species such as southern pine, birch, gum, and yellow-poplar a spud 15 to 18 inches long is commonly used; and for still heavier and harder barked species like hemlock, chestnut oak, hickory, and sugar maple a 24- to 30-inch spud may be needed.

The commercially manufactured hemlock spud is about 30 inches long. It has a sharpened hook on one edge of the blade, which is used to cut the bark where an ax cannot reach. The bark of hemlock and chestnut oak can be sold to plants that make tannin extract for the leather industry.

To debark wood at a time other than the peeling season, you must use some sort of knife barker. The most efficient is the timbershaver (fig. 24), which is like a carpenter's drawshave but larger and heavier, with the handles more in line with the knife edge to give greater pulling power;

also the blade is slightly curved to give greater contact with a round stick. For peeling poles and piling on the Eastern Shore of Maryland and in Delaware, flexible-bladed drawshaves—usually made from a section of old crosscut-saw blade—are commonly used. For shaving short bolts a shaving horse (fig. 25) makes the work much easier.

Recently a chemical process for debarking standing trees has been developed on a commercial scale. Used during the peeling season, this method consists of making a girdle 4 to 6 inches wide through the bark but not into the wood, then painting the exposed wood with a 30- to 40-percent solution of sodium arsenite in water (fig. 26).

After this treatment the tree will die in a period ranging from a few days to a few weeks. The time depends on the species. After a curing period, which also varies with the species from 30 days to a year, the bark will become very loose. On some species, notably beech, most of the bark will simply fall off the standing tree. On others like maples and oaks some hand work is neces-

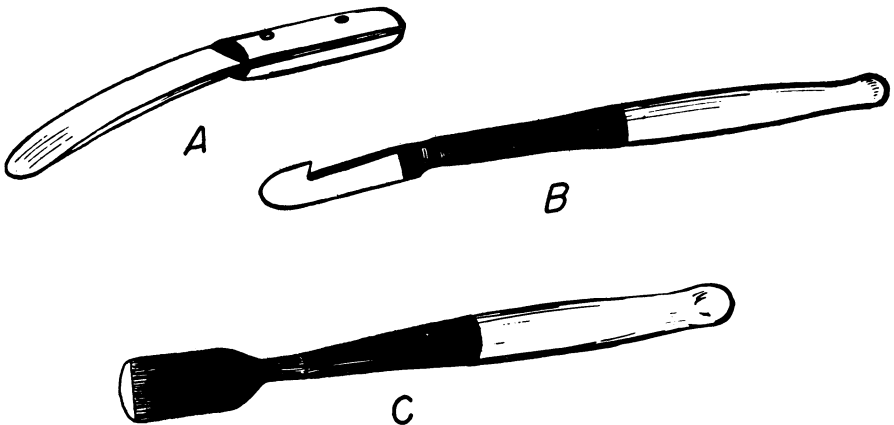

Figure 23.—Types of spuds used for peeling bark: *A*, Made from an auto spring; *B*, hemlock spud; *C*, spud favored for use on hardwoods.

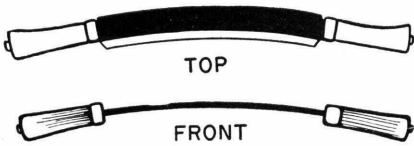

Figure 24.—The timbershove, used for debarking wood at a time other than the peeling season.

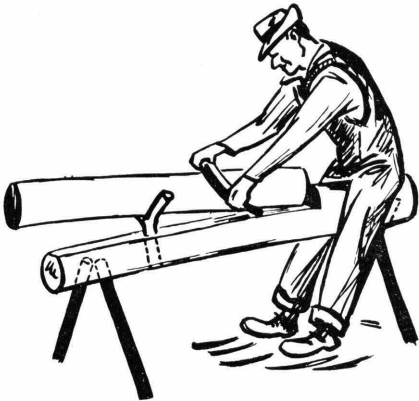
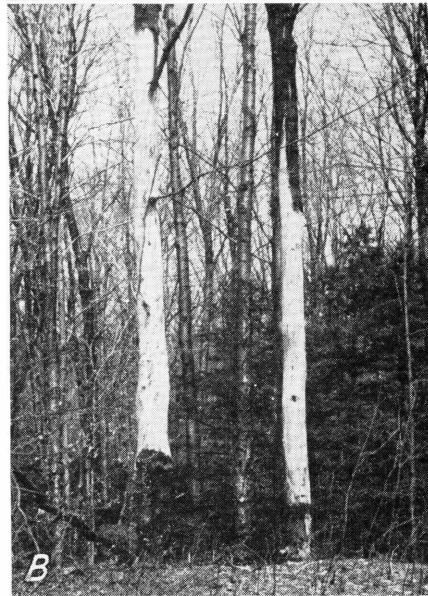
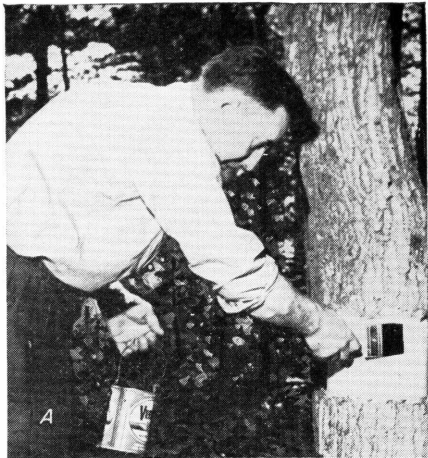

Figure 25.—A shaving horse, used to hold short bolts for debarking. The crotch support swivels around.

sary, but the bark comes off even more easily than it would in the peeling season. On birch the bark has to be split lengthwise of the stem with an ax before it can be peeled. Ash is about the only hardwood species that does not respond to the treatment. Costs of chemical peeling, including labor and chemicals, usually range between 50 cents and \$1 a cord.

The treatment is also successful on most softwoods, but pines are severely attacked by insects and fungus stains during the curing period. Most pulp mills do not want the insect-infected and stained wood.

However, the chemical used is poisonous to animals and man, and great care must be taken in its use. Tests show that absorption by the tree is almost complete in 48 hours, and livestock must be kept away from the treated area for at least this length of time. Search is being made for



B, F-468445

Figure 26.—Chemical peeling: A, Applying the chemical to the tree; B, treated trees a year after treatment; most of the bark has fallen off.

a safer chemical that will accomplish the same results, but so far none has been found. Repellents, mixed with the arsenite solution to make it unattractive to animals, are also being tried. Saponified cresote for this purpose is now available from the same sources as the arsenite solution.

Hard Hats and Safety Shoes

Although the hard hat is not strictly a tool, it is as necessary to the logger as to the construction worker. It cannot be recommended too strongly that the farmer, and all those who help him with his woods work, wear these hats. There are many hazards in the woods that can cause serious head injuries. The hard hat will eliminate or reduce most of these accidents. Hard hats would also be useful on a lot of other farm jobs.

Three types of hard hats are now generally available. One is made of resin-treated linen, one of glass fiber with a resin binder, and one of aluminum. All of them are light and easy to wear. The head is cradled in a harness of strap, so that air can circulate under the hat in the summer. In the winter a woolen liner with ear flaps can be inserted. These hats are becoming generally available at hardware stores and machinery-supply houses. They cost about \$5 each. This protection is cheap life insurance.

Safety shoes and boots are also becoming available, and the farmer who does logging might be wise to wear them. The most common has a metal box inserted over the toe, to protect the toes from being crushed. Another has a lining of woven nylon that gives the foot some protection if the uppers are cut by an ax or punctured by another tool.

SPECIALIZED LOGGING EQUIPMENT

Besides the equipment that most farmers already have, and the hand-tools that can be used in regular farm tasks, there are several specialized devices for logging that many farmers have found worth buying. Outstanding among these is the power chain saw.

Power Chain Saws

The one-man gasoline-powered chain saw (fig. 27) has been improved so rapidly and its cost has been reduced so markedly that it is now considered almost indispensable by those who go into the woods to cut timber. Accessories have been developed to make the chain-saw engine available for other uses on the farm. Among them are a post-hole digger, a brush cutter, an outboard motor, and a maple-tree tapper.



F-457283

Figure 27.—The one-man chain saw is fast replacing the crosscut saw, even in farm woodlots. There are many makes to choose from, and some cost as little as \$200.

Several makes and models of one-man saws that weigh between 20 and 25 pounds and cost around \$200 are now available. These saws are generally light machines, somewhat limited in power. Sturdier models, weighing between 25 and 30 pounds and with 5- to 8-horsepower gasoline engines, are available at prices ranging between \$250 and \$350.

There are over 30 makes of saws and choosing among them is comparable

to choosing an automobile: the selection is a matter of individual preference and of being able to obtain good local service. Generally, if you intend to cut hardwood sawlogs, or to do felling and bucking in softwoods 18 inches or more in diameter, one of the sturdier, more powerful machines is a good investment.

The newest development is the high-speed one-man chain saw, which operates off a centrifugal clutch mounted on the end of the crankshaft (most saws have used reduction gears or belts). On these direct-drive saws, the chain runs at speeds as high as 3,000 lineal feet per minute. The high speed eliminates practically all the kick and grab that is usual with conventional saws. With these high-speed saws you can make boring cuts easily, and you can cut small branches with the tip of the blade. In the first models trouble occurred because of fast wear on the chain links and on the guide bar, especially at its forward end. The manufacturers have apparently found the solution to this problem.

A chain saw is a precision machine. It needs good care and maintenance, as does the other new mechanical equipment used by farmers. An operator's instruction book usually comes with the saw you buy. Even if you have operated other power saws in the past, it will pay you to study this book carefully and to heed the manufacturer's advice.

Pay special attention to the types of oil and gasoline recommended, and the proportions in which they should be mixed. Mixing should be done in a separate can, preferably one with safety features, and not in the gas tank on the saw itself. Do not add "break-in" or "cylinder-cleaning" compounds to the fuel mixture; they may do more harm than good. It is advisable to filter the fuel mixture through a double thickness of clean cheesecloth.

Some people may tell you to use a gasoline-oil mixture different from that which the manufacturer recommends; they may tell you to use a "hotter" spark plug. Do not follow that kind of advice. If you do, you will not improve the performance of the saw except perhaps temporarily, and you may ruin it.

Sharpening the Saw Chain

It is particularly important that the chain be maintained properly. A dull chain wastes power, it wears out the saw quickly, and it cuts less wood. A poorly sharpened chain strains the saw. Many of the complaints about poor chain-saw performance can be traced directly to faulty maintenance of the cutting chain.

The "chipper" type of chain-saw chain (fig. 28) is now almost universally used. In this type of chain the cutting teeth are either L-shaped or J-shaped. Both the top and the projecting side are sharp. Ahead of each cutting tooth is a depth gage, which regulates the depth of the cut. The gage has a rounded top; riding along on the bottom of the kerf, it keeps the cutting tooth from digging in too deep. The cutting teeth have to be kept a trifle higher than the gage.

Sharpening should be done in a workshop where you have good light, firm support for the work, and warmth in winter. The best device to hold the chain for sharpening is a special clamping fixture (fig. 29). The next best is a straight section of chain-saw track. If you have neither of these, you can clamp the tongues of the driving links in an ordinary machinist's vise (fig. 30).

Do not try to sharpen the saw chain while it is on the guide bar, because it is supported too loosely. Unless the chain is held firmly you cannot gage tooth heights and angles correctly or file the teeth accurately.

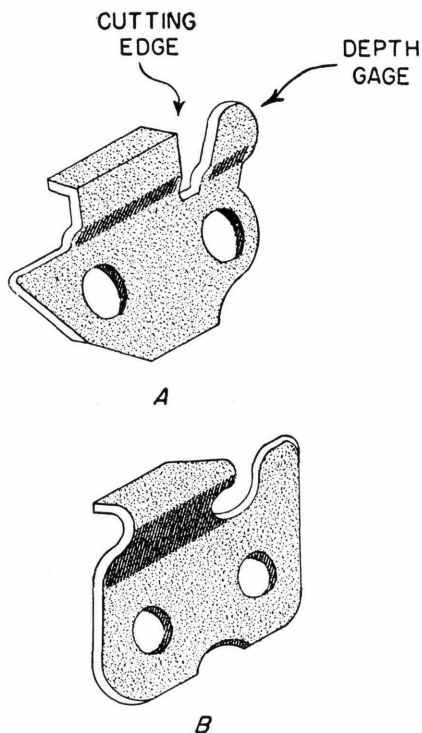

Figure 28.—Chain-saw tooth patterns of the "chipper" type: A, The L-shaped tooth; B, the J-shaped tooth.

Besides, metal filings usually fall into the groove on the guide bar and cause excessive wear.

Of course, you can touch up the saw teeth in the woods, with the chain on the guide bar. Many loggers carry a file for this purpose. In general, frequent light sharpenings are better than infrequent heavy ones.

For sharpening L-shaped teeth a special diamond-shaped file is used. For J-shaped teeth you can use a special cylindrical file, or a cylindrical hone of the right diameter chucked in an electric drill.

Most manufacturers specify the angles at which the sharpening tool should be held; and the chain the saw is originally equipped with comes fitted to these angles. These angles

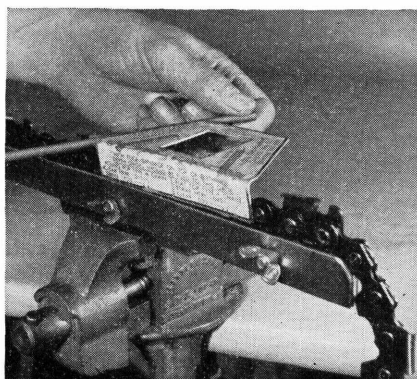

Figure 29.—A special clamping fixture for sharpening "chipper" type saw chains. Notice the file guide.

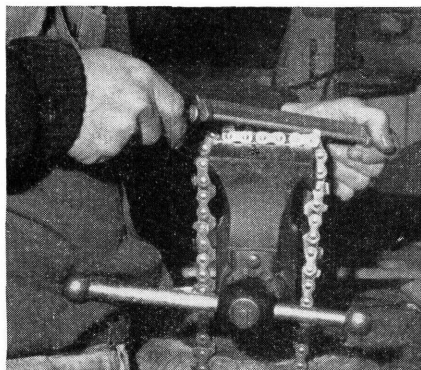

Figure 30.—Saw chain clamped in an ordinary machinist's vise.

are adjusted for average cutting conditions, and can be varied somewhat to suit the kind of cutting to be done. For example, for difficult cutting in frozen hardwoods or knotty hemlock, a less acute bevel on the teeth will result in longer wear, less breakage, and less turning-over of the edges. For cutting softwoods and "soft hardwoods" like aspen and basswood in warm weather, the cutting edges can be made more acute. Faster cutting will result.

Only the front edges of the cutting teeth should be sharpened with a file or hone. The tops and sides of the

teeth are sloped backward; they should not be touched except for a light honing to remove a wire edge or burr left in sharpening.

The "hook" of the teeth (the vertical angle of the tooth front) can also be varied within narrow limits. On most chains, as they come from the factory, a "hook" of 0 degree is used. In other words, the front of the tooth is straight up and down. Filing it back (but no more than 6°) will make the saw cut more smoothly; this angle assists in cutting the harder woods. Filing the teeth so that they slope forward (again no more than 6°) will make the saw cut faster; this angle is most often used for cutting softwoods.

After every filing, you should check the height of the depth gages to make sure they have enough clearance (fig. 31). Special devices called "jointing bars" are made for checking but a straight piece of metal (4 to 12 inches long) and a feeler gage will serve just as well. Lay the metal piece over a

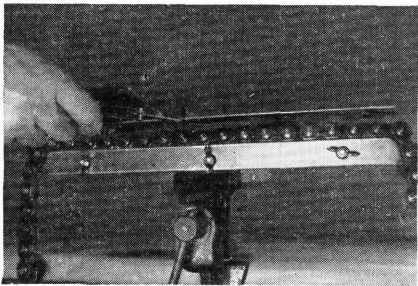

Figure 31.—Checking the clearance of the depth gages—one of the most important steps in sharpening a saw chain.

series of cutting teeth, then use the feeler gage to see how much clearance there is between the tops of the depth gages and the metal straight-edge.

The correct clearance varies with the type of cutting being done, and also with the power of the saw. When using a light saw with 2½ to 3 horsepower to cut frozen hardwoods,

you should allow no more than 0.025-inch clearance. When using a 4-horsepower saw to cut frozen hardwoods, allow 0.035-inch clearance. When cutting softwoods, you can increase the clearance to 0.04 and 0.05 inch, respectively.

Generally the depth gages need to be cut down to get the correct clearance. A flat mill file is used. The front top corners of the depth gages should be rounded off for smooth cutting.

All too commonly the depth gages are neglected in filing this kind of saw chain, or they are inaccurately fitted.

If you have to put a new tooth into a chain of this kind, because of breakage or nicking, it is essential that you file it back, from the front edge only, to the same height as the other teeth in the chain.

Generally every chain-saw owner should have at least two chains for his saw, and should keep one sharp at all times. After sharpening, the chain should be washed in kerosene to get rid of grit and filings; then it should be soaked in a can of light lubricating oil so that it will not rust and will be prelubricated.

When installing the chain on the saw, it is important that the correct tension be set and maintained. If the chain is too tight, particularly on the one-man saws, the end of the guide bar is apt to become hot and lose its temper. If it is too loose, you will have trouble from the chain coming off its sprocket and wearing excessively.

Using a Chain Saw

In using a chain saw (fig. 32) it is usually best—and safest—to keep the bumper plate at the engine end snug against the tree being cut, and then, using this as a pivot, to fan the far end of the cutting bar around the tree. Many one-man saws have curved, sharp teeth on the bumper plate



Figure 32.—The bow type of chain-saw bar is widely used for cutting small timber. In bucking especially, there is little chance of pinching and little need of wedging with this type of bar.

to facilitate this fanning motion. If you hold the bumper plate away from the tree, the cutting action of the teeth will pull the saw toward the tree and you will have to counter this force by pulling the saw toward you. It is hard to saw accurately in this way; you will be working harder than necessary, and you will be off balance and more likely to be injured.

Generally, you should shut off the engine for safety when carrying the saw from tree to tree, and even from one side of a tree to another. Certainly the engine should be shut off while the gas tank is being filled. A fire may start easily from an engine spark if this is not done. It is a good idea to fill the tank away from the place where the saw is to be run. Then if a little gasoline is spilled on the ground, there will be no danger of a hot spark from the exhaust getting into the gasoline and starting a forest fire.

At least once a day, when a chain saw is in steady use, go over it with

an oily rag to clear away pitch, rust, and sawdust. Clean out the air cleaner and the cooling fins around the cylinder by the means provided, and test all exposed screws and nuts for tightness. The chain-oiling device should be tested, to see that it is working correctly, and the groove under the chain should be cleaned out if it is dirty or gummy. A bent piece of heavy wire is suggested for this job. A drop of lubricating oil on each throttle and choke-control linkage point will result in easier operation. This periodic inspection, oiling, and tightening will pay off in good performance.

At intervals of about a week, give the saw a more complete inspection and cleaning, besides attending to the items covered in the daily checkup. Remove the fan cover and clean the fan and cooling passages. Check the transmission lubricant. Inspect the guide rail and sprocket for wear and—on the makes that permit it—reverse them to equalize wear. Scrape carbon deposits out of the exhaust ports. Remove and clean the air and fuel filters. Remove and clean the spark plugs, and set the firing points to the proper gap. Finally, start the engine and check it for general performance. Note particularly any abnormal sounds that might indicate trouble developing. Note whether idling speed is

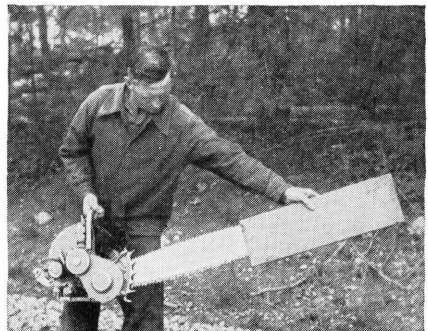

Figure 33.—A simple plywood guard for the chain saw.

satisfactory, and check the carburetor adjustment as explained in your instruction book. If anything serious seems to be going wrong, get in touch with your local chain-saw service station.

When transporting a chain saw in a truck with other tools or with men, use a plywood guard to protect the saw teeth and the men (fig. 33).

More pointers on chain-saw use will be given in the sections of this bulletin dealing with felling and bucking.

Wheel Circular Saws

The wheel circular saw is good for felling and bucking in level, open woods. Many of them are still used in the flat pine woods of the South, with excellent results. The wheel circular saw has a frame something like an oversize garden cultivator, with a gasoline engine mounted between the shafts. A circular saw is mounted in front of the frame on a swivel arm, so that it can be used either horizontally or vertically. A V-belt or flexible shaft connects the engine and the saw.

Use of these saws is both arduous and dangerous, especially in hilly, rocky, and brushy woodlands. Even in the South, where they were developed and are commonly used, these circular saws are being replaced by the one-man gasoline-powered chain saw.

The wheel circular saw can easily be adapted to use as a semipermanent bucking rig for use in cutting fuelwood.

Other Types of Power Saws

Several other types of power saws may be useful in special situations. One of them is the old fashioned drag-saw. This is a heavy-gage crosscut saw that is pulled back and forth by a pitman arm attached to a flywheel

on a gasoline engine. Dragsaws have been used on farms for a long time, for cutting short bolts for fuelwood, shingle bolts, and the like. They are sturdy and relatively trouble-free, and many farmers have made their own. However, since dragsaws cut much more slowly than chain saws, they need more fuel for the same amount of work.

A small portable saw that cuts with this same back-and-forth motion has recently been put on the market. Except for a toothed blade, it looks like a chain saw, and weighs only 25 pounds. It has a short stroke, and works at a very high speed: 160 strokes per second. Because of the short stroke it is difficult to free the gullets of sawdust in cutting large pieces, so the saw must be rocked back and forth continually. These saws also cut more slowly than a chain saw. But they make a very smooth cut. Because of their high speed there is no pull on the engine; so it is easy to cut small limbs and saplings with the tip of the blade.

Several makes of circular rim saws are also available. They have the same advantages and drawbacks as the bow-type blades used on the chain saws. Within their capacity (generally 12 to 18 inches) the circular rim saws do a good job, with little danger of pinching. They are somewhat more awkward to handle in felling than the conventional chain saw. Also, they are heavier than the chain saw, because they use a 4-cycle gasoline engine rather than the 2-cycle engine used in a chain saw. Attempts are being made to overcome this disadvantage by placing the engine on the ground and transmitting power to the saw through a flexible shaft.

Antifriction Devices for Skidding

When logs are dragged directly on the ground, much of the power used is wasted in overcoming friction.

Then too, much dirt and gravel becomes embedded in the logs. Many owners of sawmills, especially in the glaciated sections of the country where dirt and gravel are highly abrasive, do not like to handle dirty logs. This is particularly true of small sawmills, which provide an important market for the logs from farm woodlands, and which usually do not have log-washing facilities.

By using an antifriction device such as a sled, a pan, or a sulky, you can skid bigger loads and can bring in cleaner logs.

Most logging sleds are homemade. They are used commonly in New England, the Lake States, and adjoining parts of Canada. Their use in the West, especially in the Rocky Mountain region, is increasing. Originally, use of sleds was confined largely to the winter months, when most of the logging was traditionally done; but they have been found useful at other times of the year. There are many different types of logging sleds. The commonest are the go-devil, the scoot, the sloop, the yarding sled, and the dray.

The go-devil (fig. 34) is a simple, loosely articulated sled without thills (shafts) or a tongue. This sled is generally used for skidding long logs behind a single horse. The two run-

ners are usually made from butt sections of naturally curved hardwood poles 6 to 8 inches in diameter and about 6 feet long. They are generally used unshod. The crossbeam, which is attached to each runner with a single bolt a little back of the center, is usually a sawn or hewn hardwood timber about 4 or 5 inches thick and 6 or 8 inches wide. It may be 4 to 6 feet long. The front ends of the runners are kept apart by a roller, often a section of iron pipe strung on a chain. The hauling chain is attached to each end of the crossbeam, usually by an eyebolt, and brought forward under

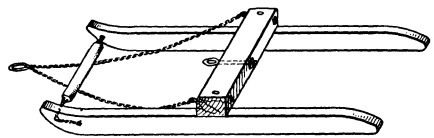

Figure 34.—The go-devil.

the roller. The front ends of the logs to be hauled are fastened to the crossbeam with another chain, which may be wrapped around the beam or run through another eyebolt in its center.

The yarding sled (fig. 35) is a little more elaborate. The crossbeam is attached to the runners with wooden or steel raves; and it has thills or a tongue. For use behind a tractor, a

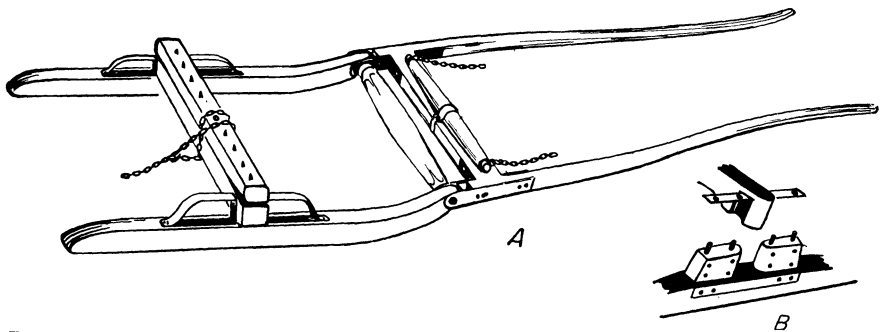

Figure 35.—A, Details of the yarding sled; B, another way of attaching the crossbeams.

tongue about 4 feet long, which can be attached to the tractor drawbar, is used. Frequently a swiveling bunk is fastened to the middle of the cross-beam by means of a king bolt. When this is done, the logs can be chained securely to the bunk, and the load can be taken around curves without racking and sideslipping. When the logs have to be chained directly to the crossbeam, the chain should be attached at the center only (fig. 36). The runners of the yarding sled are usually shod with strips of steel.

The dray (fig. 37) is a yarding sled with two long poles attached to the bunk. It is used for carrying short bolts of wood piled crossways.

The scoot (fig. 38) is a heavy sled on which logs or bolts are carried completely off the ground. This sled is built in several different sizes, depending on the pulling power to be used,

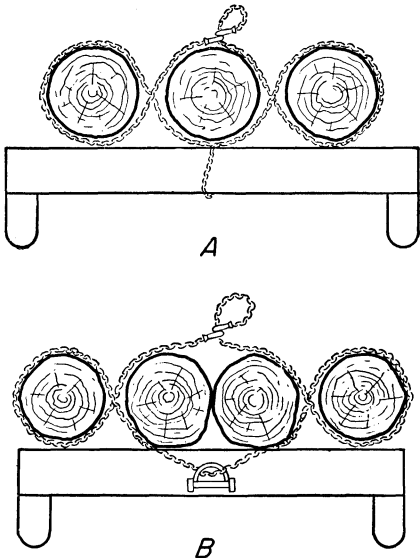

Figure 36.—The "Baltimore hitch" for fastening logs on a yarding sled: *A*, The chain is passed around the crossbeam; *B*, a D-ring is attached to the crossbeam to hold the chain.

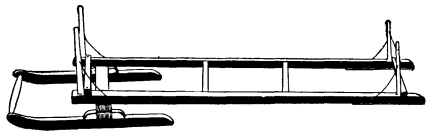

Figure 37.—A dray for carrying pulpwood.

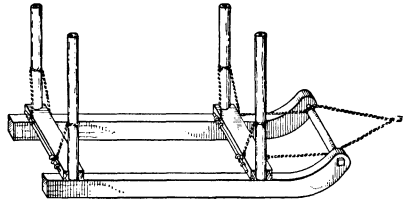

Figure 38.—A logging scoot for use with horses.

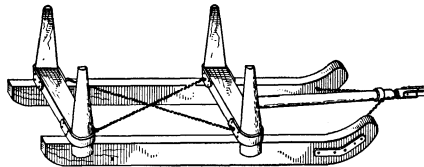

Figure 39.—The sloop is like the scoot, but sturdier, and is used with a tractor. Notice the rigid tongue.

ranging from a horse to a heavy tractor. The scoot also has no thills or tongue. A similar sled with a tongue is called a sloop (fig. 39). Both of these sleds are commonly used in summer and winter, especially in New England and the Lake States. There are many variations in construction details.

The skidding pan (fig. 40) is primarily a tractor-skidding accessory. It is a flat piece of sheet steel or boiler plate, turned up at the front and attached by a short length of chain to the tractor drawbar. The logs to be skidded are encircled with chokers of chain or wire rope, which are hooked to the tractor drawbar. As the tractor moves forward, the front ends of the logs roll over onto the pan, which keeps them from digging in as they

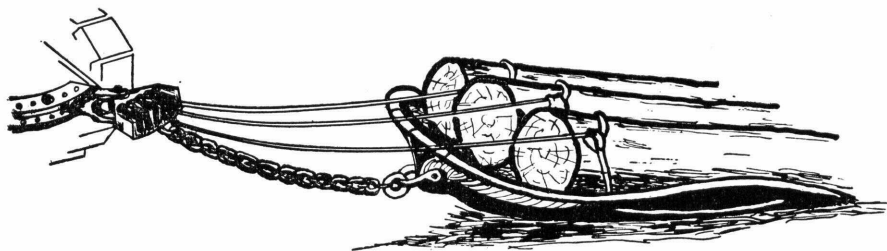

Figure 40.—The skidding pan is used with a tractor.

are pulled toward the landing. Draw-bar hitches that will accommodate 3 to 24 choker ends are available from tractor dealers.

The logging sulky (fig. 41) is a smaller, rubber-tired variety of the giant logging arches mounted on crawler tracks, which are so commonly used in west coast logging. The smallest commercially available logging sulky suitable for use with wheel tractors weighs 465 pounds, complete with 20 x 6-inch tires and tubes; it costs about \$250. Farmers have built similar sulkies, using old truck parts, at a cost of about \$100.



F-457264

Figure 41.—A small logging sulky suitable for use with a small tractor.

Together with a rear-mounted winch and cable, the sulky makes it possible to reach out and assemble a load of logs from places where it would be difficult or dangerous to take the tractor, and to bring a bigger, cleaner load of logs to the landing.

To be serviceable, a sulky must be sturdy and stable—at least as wide as it is high. The model mentioned above is 59½ inches wide and 48 inches high, from the top of the fairlead to the ground. The fairlead is made up of three rollers. The main roller is horizontal; the other two, one at each side of the main roller, are vertical. The space between the rollers should be large enough so the hook on the end of the wire rope, with its load of choker hooks, can pass through.

Other Specialized Devices

There are other specialized devices that the individual farmer-logger can use. Whether you want to buy a piece of equipment will probably depend on the type of timber products you are making, and the amount of logging you are doing.

Buzz Saw

One device is a cordwood-cutting rig (fig. 42). If you are burning a lot of fuelwood or can sell it, one of these rigs may easily pay for itself. They range from a simple buzz saw driven from the power takeoff on the farm tractor, with a rocking table to carry the wood, to an automatic saw with a belt or chain conveyor to carry the sticks to the saw. By means of an automatic feed system, the saw cuts sticks to exact lengths and another

conveyor carries the cut sticks away. The buzz saw will generally cost less than \$100, and the automatic wood saw will cost about \$1,000 without a motor. Many farmers build their own cordwood rigs, ranging in size and elaborateness between these two extremes.



F-449907

Figure 42.—The buzz saw is the most common rig for cutting cordwood.

Wood Splitter

The farmer who is producing considerable fuelwood may need some kind of wood-splitting machine. Many farmers in the Dakotas have rigged up splitting wedges on old steel-shod tractor wheels, which are powered by a 3- to 5-horsepower gasoline engine or an electric motor (fig. 43). For safety, the wheel must turn no faster than 100 r.p.m., and bolts must be countersunk in the wedge. These rigs are reported to

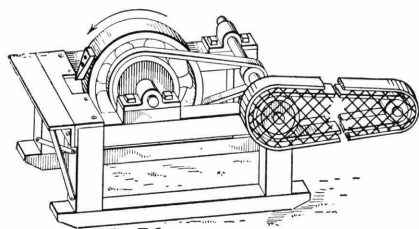

Figure 43.—A wood splitter made by fastening a splitting wedge on a large wheel. An old-fashioned steel tractor wheel is often used in making one of these machines.

work well, enabling a man to split 10 to 30 cords a day. Other farmers have built themselves more conventional splitters, using a wedge mounted on a bar that is moved up and down by a crank attached to a powered flywheel.

Conveyor Loader

Another device that many farmers producing pulpwood and fuelwood have found worthwhile is a light conveyor loader for carrying short lengths of wood up onto a truck (fig. 44).

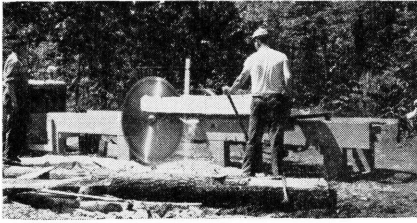

Figure 44.—An inexpensive pulpwood conveyor-loader makes this job easier.

Small Sawmills

A farmer may even want to buy a small sawmill. A hand-fed model can be bought for as little as \$150; the cheapest power-fed machines cost somewhere around \$500 (fig. 45). These small mills when operated by experienced people are capable of making remarkably good lumber. A large variety of accessories, including trim saws, edgers, conveyors, and even inexpensive planers are available. With such a mill you can make the lumber you need around your home place from your own logs, and you can manufacture lumber for sale.

A still less expensive means of making squared timbers or heavy plank, for a farmer who already has a high-powered chain saw, is to buy an accessory device that will enable him



F-450147

Figure 45.—A small and inexpensive sawmill. (A screen should be provided to protect the sawyer's face from flying sawdust and chips. Belt and pulleys should have guards.)

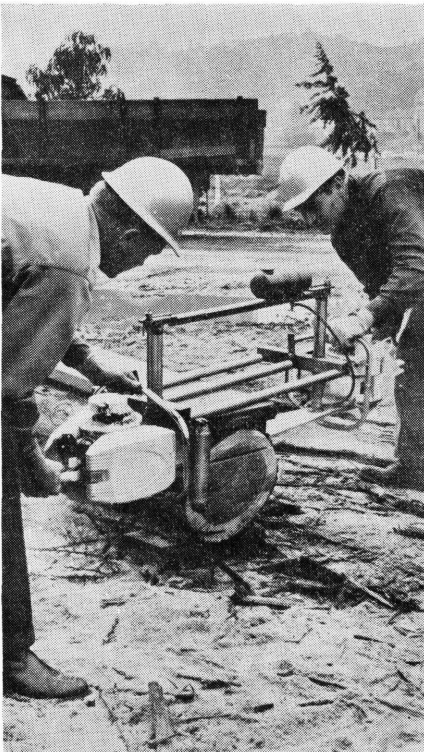

Figure 45a.—Chain-saw sawmill. Leveling plank on top of log. Mill is guided by the rollers on surface of plank. Saw will next be lowered for second or bottom cut.

to make squared timbers or heavy plank, for a farmer who already has a high-powered chain saw, is to buy an accessory device that will enable him to make straight ripping cuts through logs (fig. 45a). This consists of a couple of upright rods which are fastened to each end of the chain-saw cutting bar. These rods are connected by an adjustable set of rollers. For the first cut on a log, a plank is spiked on top of it and the roller guides adjusted so that the chain-saw bar will be at the depth of the slab to be cut off. With the rollers riding on top of the plank, two men then push the saw the length of the log as it cuts off the slab. A second side of the log can be squared up in a similar manner. For subsequent cuts, the depth of the roller guides is adjusted to the depth of planks or timbers desired to be removed from the log.

Portable Chipper

Another device that appeals to many farmers is a portable chipper (fig. 46). Many soil specialists now recommend wood chips as a source of organic material for cropland. Drum-type chippers, some of which can be mounted on standard farm tractors, and some of which are mounted on



F-457239

Figure 46.—A portable chipper can be used to make mulch or bedding.

trailer wheels along with their own engines, are available from several sources. These come in different sizes, the smallest taking material up to 4 inches in diameter, the largest up to 14 inches. They can be set to make different sizes and types of chips, some being well adapted to use as bedding for horses and cattle, some as chicken litter, some as mulch for fruit trees, and others for direct addition to the soil. You should consult your local extension agent or college of agriculture for advice about uses of wood refuse in your locality.

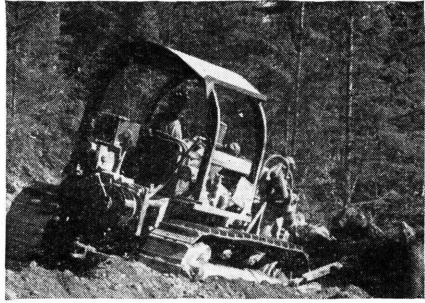

F-441705

Figure 47.—Heavy equipment can often be rented. A bulldozer operator will usually contract to build a good woods road quickly and cheaply.

Getting Special Equipment on Contract

On most farms there simply is not enough woods work to justify the cost of buying special logging equipment like that described above. But if you need some special equipment, there are two possibilities you should consider.

One possibility is to buy the machine you need and to rent it out occasionally to neighbors, either with or without your services as operator. In this way you may be able to defray part of the cost and to make the machine pay for itself. Of course, you should make sure that there is need for such a machine in the neighborhood, and that there is an opportunity to rent it out, before you invest in it.

The other possibility is to hire the use of a machine from somebody else. In many localities expensive and specialized machines may be rented or brought to your place on contract. For example, you may need a new truck road into your woodland, the construction of which will involve considerable earth-moving. A local owner of a tractor-bulldozer combination can usually be found who will come to your farm and do the job for you in a few days (fig. 47). Sometimes these machines are available from the local township or other governmental unit.

Other special tools, needed for a short time only, often can be rented from local logging and construction contractors. Examples are logging cranes, cable-skidding rigs, and shovels or dragline machines. Even such specialized devices as mobile debarkers or pulpwood chippers may be available on loan or contract from companies using the wood, if the quantity of wood available justifies bringing the machine to the farm. Most frequently such machines are brought to a railroad siding or mill yard to handle the products of a number of farm logging jobs.

LAYOUT OF THE LOGGING JOB

Although a farmer cannot afford to do many of the things that a commercial logger does, he should consider a few permanent improvements in his woodland to make the logging job easier and more efficient.

You will rarely have to consider building a camp in the woods for men, or sheds for machines or livestock. However, an investment that is frequently worthwhile, particularly in the northern regions, is a simple warming shelter. It can be semipermanent, but a portable building with a little stove in it would be better. Used at lunchtime during the winter,

it gives protection against the cold and wind. If built of homegrown lumber, it need not cost more than a few man-days of labor and a few dollars for hardware and roofing; and it will be worth far more than it costs. Such a shelter may be invaluable if anyone is injured while at work in the woods.

Logging Roads

Most farmers go into their woodlands year after year to bring out wood for home use, as well as timber for sale; hence, a little inexpensive work on the logging road will usually be a good investment. A good dry-weather road or a winter truck road can often be developed cheaply by handwork alone if an old road or trail is already there. Often a new road can be cut at a reasonable cost by a local bulldozer operator, who can be hired with his machine on a contract basis.

The amount of road building that will pay depends on the individual situation. Of course, the first item to consider is the cost. Commercial loggers figure cost according to the amount of timber to be logged. For example, a \$5,000 road built into the woods to bring out 5 million board-feet of logs will cost about \$1 a thousand. Comparing skidding costs and truck-hauling costs, the logger often finds that he can save money by building a road. The saving is usually due to the lower cost of truck-hauling.

On the other hand, where road-building would be expensive, you might find it cheaper to skid long distances, and so put less work and money into a road.

In laying out a logging road, locate the truckloading point as close as possible to the place where the wood is cut. This arrangement reduces skidding costs. If the road has a dead end, space should be provided for a turnaround. Curves should have a radius of not less than 80 feet.

Although the 4- and 6-wheel-drive trucks now in use to collect wood products can travel over fairly rough roads and can go up slopes as steep as 15 percent, road grades should be kept as gentle as possible.

The road should be built on solid ground; boggy places and stream crossings should be avoided to reduce construction problems and maintenance costs. Drainage is important. Drainage should be provided along the road and across it where necessary, so that water will not collect. Thank-you-ma'ams (fig. 48A)—ridges of dirt across the road to divert the water to one side—will help to keep the water from rushing down the road and washing it out. Open-top pole culverts (fig. 48B) can also be used. It may be wise to keep vehicles off the road during the muddy seasons in spring and fall.

In figuring the cost of a road for logging, you should also consider its value for other purposes, such as fire protection, maple-sugar production, or even recreation.

Skid Trails

In hilly or mountainous country, a network of permanent, well-laid-out skid trails in a woodlot will make logging easier. Often such a set of trails is the first step toward good forest management.

Many farm woodlands are already laced with old skid trails, relics of former logging jobs. Often these are well located, and to be useful again they need only the cutting of a little brush. Other trails are no longer useful because of changes in the location of main roads, or because of poor original location. Sometimes the old skid trail was straight up and down the slope, and water washing down has made it a gully. New skid trails should not be made in such places.

The distance between the skid trails will depend on the topography of the

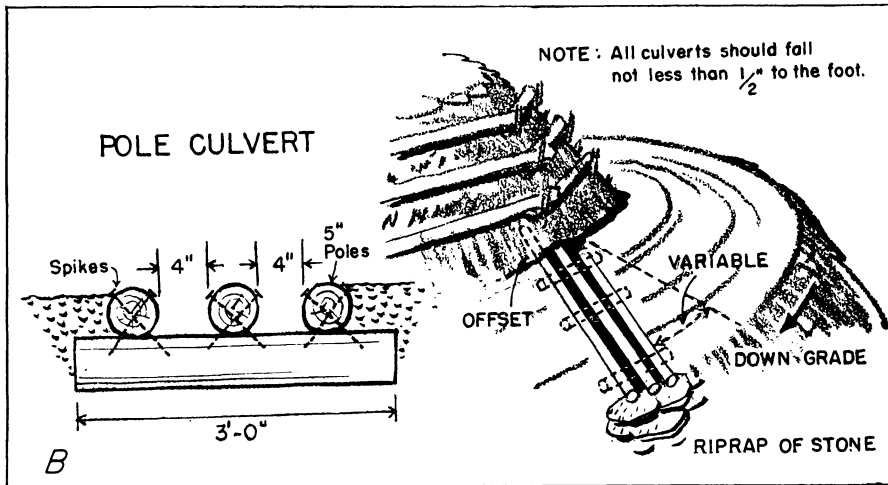
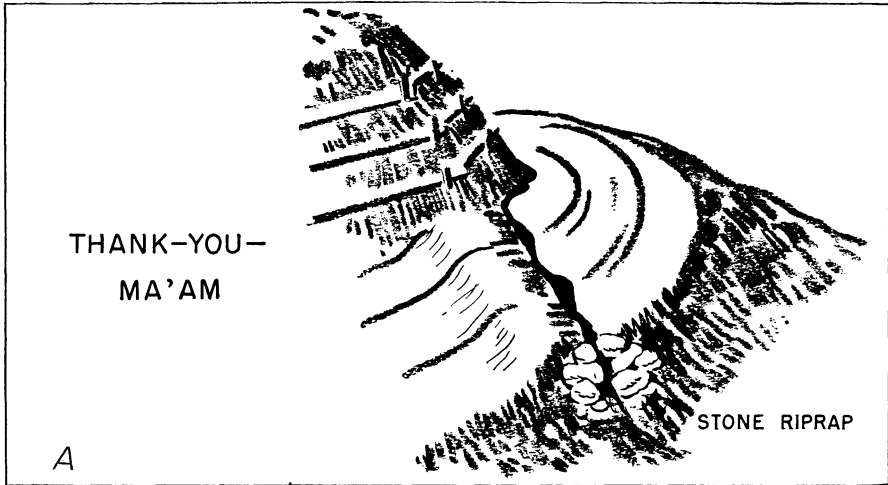

Figure 48.—Thank-you-ma'ams and pole culverts can be used to drain water off logging roads: A, A thank-you-ma'am is a ridge of earth thrown across the road; B, details of an open-top pole culvert.

land and the skidding methods to be used. Under favorable conditions, even a small tractor equipped with a rear-mounted winch can collect a load over a radius of 75 feet or more. If directional felling is practiced, trails for tractor-skidding can be located 200 feet or more apart. On the other hand, trails for horse-skidding short logs need to be considerably closer together. Generally they should be

no more than 100 feet apart, and much more carefully laid out as to footing and slope.

Trails for horse-skidding short logs, or for transporting bolts on drays or scoots, may be narrow and relatively crooked. For tree-length logging with horses or medium-size tractors, the trails need to be straighter and wider. A slight downgrade is best. Upgrade pitches, or even level places,

will materially reduce the amount that can be skidded. Swampy places, rocks, and stumps in the trail will be sources of endless trouble.

To construct a skid trail for horses, brush cutting and some simple work on the footing are often all that is needed. Sometimes it will be desirable to install fender logs (fig. 49) to keep the logs from rolling off the trail on a side slope or to guide them around an obstruction.

To make skid trails for tractors, more work is required. Of course, a crawler tractor equipped with a bulldozer blade can almost make its own trail. But for a wheel tractor, more careful work is needed. The trail should be leveled crossways, so that there is no danger of the tractor's slipping sideways or tipping over. Rocks, stumps, and protruding roots and stubs should be removed. This extra work will be repaid in greater safety for the operator, fewer break-downs, and quicker round trips to the landing.

With a little forethought in locating a skid trail, you can avoid going through patches of valuable small trees; and you can prevent damage to valuable trees that should be saved for future cuttings. Try to plan your trails so that your logs will not rub against good standing trees and scar them.

Where a skid trail must go up a slope you can reduce washing out by installing thank-you-ma'ams. On steeper slopes you should space these ridges of earth about 50 feet apart. You can

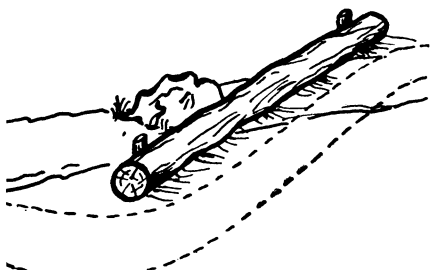

Figure 49.—Use of a fender log on skid trail.

also use open-top pole culverts. After logging has been completed and the drainage devices have been put in, brush and limbs can be placed in the ruts and on the bare surfaces; this woody material will help further to prevent washing of the soil. A 10-foot-long mat of limbs about every 50 feet, with the tops pointing uphill and in close contact with the ground, is recommended for the steeper slopes.

Landings

Usually the skid trail will come out to a place where the logs or boltwood can be loaded onto a truck. This loading area is called a landing. It should be in a clearing, with space enough for a tractor to turn around and space for piling the wood. Much logging nowadays is done in tree lengths: the stems are skidded in entire and they are cut up into logs or bolts at the landing. The layout and equipment for this operation also take room at the landing.

You may have to store logs and bolts at your landing until you can haul them away. It is not safe to leave logs on the ground very long, especially during the summer months. They will deteriorate quickly. Pile them on skids so that they are off the ground and air can circulate under them.

To protect high-grade hardwood logs from end-checking (and from the stain and decay that often follows) you can use an end-coating, preferably one of the asphaltic or rubber compounds. An additional treatment with a chemical spray to prevent insect and fungi attack is often advisable. You can get further information on this subject from the Northeastern Forest Experiment Station, Forest Service, Upper Darby, Pa. (for northern hardwoods) and from the Southern Forest Experiment Station, Forest Service, New Orleans 12, La. (for southern hardwoods).

Pulpwood and fuelwood are often piled directly on the ground, either in ricks or in rough-and-tumble piles. But when the wood is to be stored for more than a week or two in the summer months, get it off the ground to reduce the possibility of rot, stain, and insect damage. You can do this easily by building your ricked piles on two skids. Raising the pile off the ground not only protects the wood, but it also hastens drying and makes the wood lighter and easier to haul. The ends of a ricked pile can be held in by stakes supported with croched props, by forked sticks tied into the pile, or by building the pile between standing trees (fig. 50).

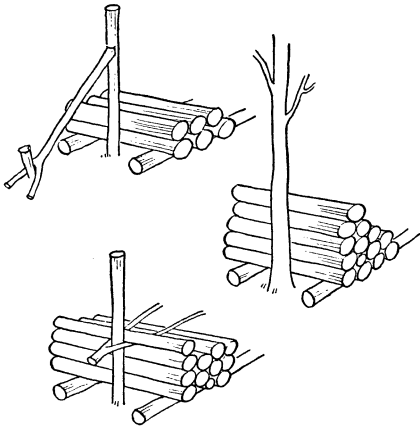

Figure 50.—Methods of holding ricked piles of wood together.

Ricking the wood makes it possible to measure the overall dimensions of the pile (a standard cord is 128 cubic feet of stacked wood, usually a pile 4 by 4 by 8 feet). Wood piled rough-and-tumble takes up more space, and cannot be measured accurately until it is stacked on the truck.

An increasing number of purchasers of short wood require the wood to be piled so that it can be handled in bundles. Some purchasers provide tubular-steel pallets (fig. 51) for their

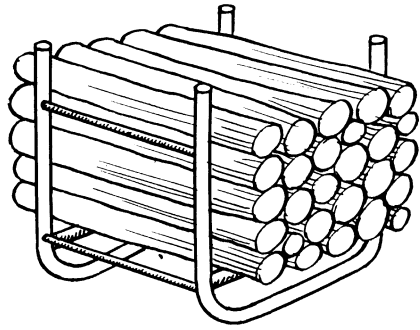

Figure 51.—Tubular steel pallet for handling boltwood in bundles.

wood producers and require that the wood be piled in them. These pallets are then pulled directly onto a specially equipped truck. Others require that the wood be piled on skids or in racks so that a cable sling or steel hoop can be passed around for loading with a crane (fig. 52).

Skidways

Skidways can be used both as a place for storing logs at the landing and as a deck for loading logs onto a truck. In hilly country the skidway (also called a "brow") can usually be built on a slope, so that the logs can be rolled onto it directly from the skid trail above, and then off onto the truck at the same level (fig. 53).

The skidway should be constructed of low-grade or unmerchantable material, so that valuable material will not be left after the loading is completed. When the skidway is being filled with logs, care should be taken that the front log is blocked or held in place so that it will not roll off into the roadway.

Double-decked skidways are popular in the Northeast. These skidways make it possible to roll the first tier of logs onto the truck from the bottom deck, and then to complete the third and even fourth tiers from the upper deck. This avoids uphill rolling.

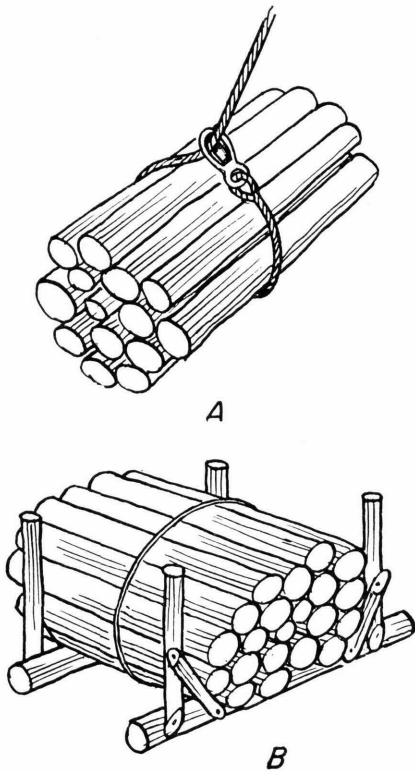

Figure 52.—Wood piled in racks can be handled as a bundle: A, A self-tightening cable sling used to pick a bundle of wood from a rack; B, metal hooping is used to make a bundle.

MARKING AND MARKETING

The first step in logging is to select the trees to be cut. The farmer who wants to keep his woodland productive should consult a forester. In many States publicly employed foresters are available to help the farmer mark the trees to be cut, and to assist him in finding a market for the products. Your county agent can tell you if there is such a service in your locality.

You should certainly find out before you start cutting, what the local markets will buy, how much they will



F-445463

Figure 53.—A skidway or "brow" for storing logs and rolling them onto a truck.

pay for the different products, and what specifications they have. Many a farmer has cut timber without getting this information, only to find that the mills were not buying wood at that time, or that he had not cut the wood to the sizes wanted, or that there was no market for the product he had cut.

If you have pulpwood to cut, get a sales contract, or an agreement with the mill. Most pulp mills put out printed sets of specifications to tell you what they want: the species acceptable and how they should be segregated; the sizes to be cut, in both length and diameter; the amount and kinds of defects acceptable; and how the material should be prepared and stacked.

Most veneer mills, boltwood mills, mine-timber purchasers, and pole and piling yards have the same kind of specifications. However, sawmills ordinarily do not have such strict specifications; but before you start cutting, visit the local mills and find out what they are buying, how much they pay, and what requirements they set as to length, diameter, and allowable defect.

Generally, if you have enough suitable timber, you should plan an integrated or multiproduct operation. This means you should cut each tree, or portion of a tree, into the most valuable product that it is capable of producing. For example, second-growth southern pine and other coniferous

fers, such as Douglas-fir, lodgepole pine, red pine, and spruce, which grow into tall, straight, slim trees, will often bring the highest price if they are cut into poles and piling. But large, clear logs of many of the better hardwoods, including black walnut, white oak, yellow birch, hard maple, yellow-poplar, and the gums, are often worth twice as much when delivered to a veneer mill as they are at a sawmill. Other high-priced specialty markets in various parts of the country buy high-quality white oak for tight cooperage, white birch for turning stock, white ash and hickory for skis and handle stock, red and white cedar for shingle stock, and white pine for pattern stock or match blocks. Some sawmills that have special markets are able to pay much more for logs that meet their requirements than other sawmills.

If you do not know whether a local forester is available to give you advice on these marketing problems, consult your county agent, your extension forester, or your State forestry department, which is usually located at the State capital. Neighbors who have had experience in marketing forest products can also help.

Methods of measuring and marketing farm wood products are described in detail in United States Department of Agriculture Farmers' Bulletin No. 1210, *Measuring and Marketing Farm Timber* (revised 1958; 25¢).

FELLING

Once the trees have been selected and markets found for their products, you are ready to start cutting.

First, you must determine in which direction you want the tree to fall. Put it down where limbing, bucking, and skidding can be done most conveniently. Tops should usually be kept out of the skid trail or road. Otherwise it will be necessary to rehandle all the limbs to get them out of the way after they have been cut

off. Of course, the tree should not be dropped where it will be broken by falling on stumps or rocks, or where it will be inaccessible because it bridges a depression or is tangled in thick brush.

Where tree-length tractor-skidding is to be done with winch and cable, it is usually better to fell the tree at an angle toward the skid trail, so that the entire length can be pulled out top end first without switching it around. Trees to be cut into logs or bolts in the woods, which are then to be skidded out by a horse or small tractor without a winch, are generally best felled at an angle away from the main skid trail. Thus it will not be necessary to go through the brush created by limbing to get the skidding equipment to them.

A small tree can usually be dropped in any direction. But sometimes there is little choice of direction in felling big trees. Some trees, because of pronounced lean or heavy limbs on one side, can be felled in only one general direction. Even with these, however, the direction of fall can be changed as much as 30° by judicious wedging or "holding the corners" (described later).

Try to avoid felling a tree in the direction of other trees that have dead limbs. Such limbs may be knocked loose as the tree falls, to catapult back toward the cutters. Limbs may also be knocked off the tree just cut. These flying limbs are called "widow-makers," and rightfully so. Tree felling is one of the most dangerous woods jobs. Always wear a hard hat when you fell trees.

A tree felled up a steep slope may kick back on hitting the ground, endangering the felling crew. A tree felled on an obstacle, such as a log or rock, may thrash around in unpredictable ways. Avoid felling a big tree toward another tree, especially one that has a heavy crotch. It is almost sure to become lodged; the

loggers call it "sky-hung." You may easily waste half a day getting a lodged tree down, and you may hurt yourself or your helper.

In summary, try to pick a place to fell your tree where it will not bring down a shower of dead limbs or become lodged, where it will do the least damage to surrounding growth and to itself, and where it can be trimmed and skidded out most easily.

Take two safety precautions: First, plan the getaway route you will take when the tree starts to fall. Second, clear away underbrush and overhanging limbs so that you will have a clear place to work.

To bring a tree down in the direction wanted, make an undercut on the side toward which it is to fall, approximately a quarter of the diameter deep. Most undercuts are made by first sawing the bottom part of the notch and then chopping down to this cut with an ax. You can also saw it out with a power saw.

The back of the undercut should be at right angles to the direction in which the tree is to fall. The direction of fall can be tested by placing a double-bit ax in the cut and sighting down the handle (fig. 54).

Start the backcut (fig. 55) on the other side of the tree, about 1 or 2 inches higher than the undercut. If



F-382747

Figure 54.—Testing the undercut to make sure the tree will fall in the direction wanted. (Man should be wearing a hard hat.)

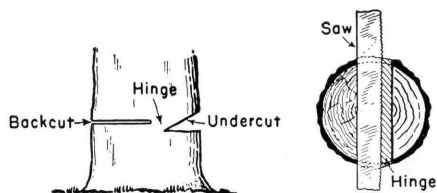

Figure 55.—Making the backcut. Notice the narrow strip of wood left uncut to serve as a hinge when the tree falls.

the tree is straight and well balanced, saw directly toward the undercut, inserting wedges behind the saw if need be, to prevent pinching and to start the tree tipping. Do not saw all the way through to the undercut. Leave an inch or two of the wood uncut to act as a hinge when the tree goes over.

Felling with a chain saw is much like felling with a handsaw. However, the difference is that with most chain saws you can cut on an upward slant, so that the undercut is frequently made upside down. This method of cutting leaves the butt log practically square at the bottom, and saves some of the most valuable wood in the tree.

When using a chain saw a backcut is most easily made with a fanwise sweep of the blade (fig. 56). If the blade is long enough to go completely through the tree, the cut is made in one sweep, with the bumper plate at the engine end held against the tree a few inches in back of the point of the undercut. If a one-man saw that will not go completely through the tree is being used, a cut is made on one side, and then the saw is carried around the tree and another fanwise cut is made on the opposite side. Still larger trees will require three sweeps of the blade, the first one at the back, opposite the undercut.

If the tree leans at right angles to the direction in which you want it to drop, you should "hold a corner"; that is, do not saw so close to the undercut on the side opposite the lean

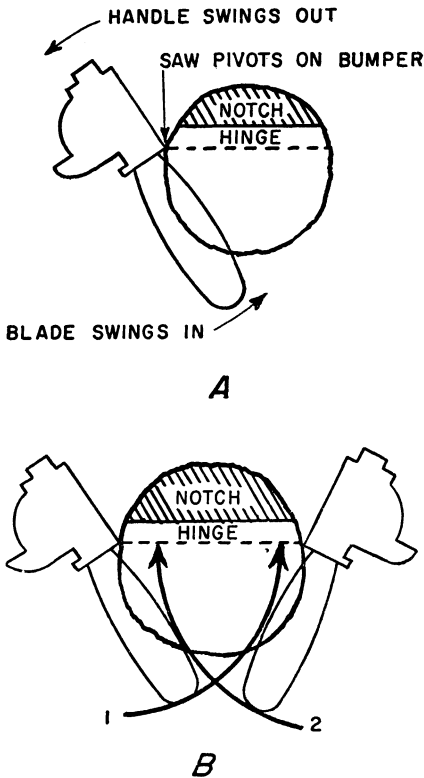

Figure 56.—Use of a one-man chain saw in felling: A, Method of cutting a small tree in one sweep; B, method of making two cuts to fell a larger tree.

(fig. 57) as you do on the side of the lean. It is also a good idea to insert wedges on the side the tree leans toward.

If a tree leans the way it is being felled, it is apt to fall prematurely, splitting up the stem and leaving attached to the stump a slab split off the butt log—a “barber chair.” This splitting is dangerous and destroys much valuable material. To prevent splitting, first make a deep undercut by sawing a third or even half the diameter of the tree. Then chop out or saw off the corners. This is done by making small additional undercuts, usually with an ax, through the sapwood at each of the back corners

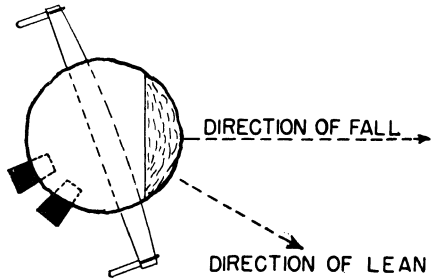

Figure 57.—“Holding a corner” and wedging to bring down a leaning tree where wanted.

of the undercut, at about a 30° angle with it, or by cutting through the sapwood at each side with the saw. Then make the backcut.

A good trick to insure against splitting is to wrap a length of log chain around the trunk a few feet above the cut, and wedge it tight (fig. 58). Make sure that the end of the chain does not dangle where it will be hit by the saw.

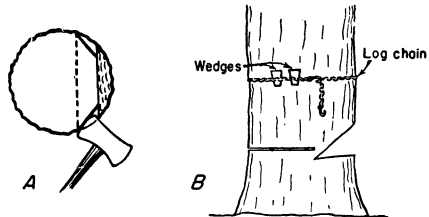

Figure 58.—Ways to prevent splitting of a tree: A, Chopping out the corners of the undercut; B, binding the tree with log chain and wedges.

Finally, a minute or two before the tree starts to go over, give a warning signal to anyone who might be in the way of the falling tree. Yell “*Timber-r-r!*” as loudly as you can. Or blow a whistle. Don’t assume that you and your partner are the only people nearby.

As the tree goes over, the felling crew should move back and away from the stump, taking the saw with them. Many a saw has been ruined by being struck by a falling tree.

Use the getaway route you planned and cleared in advance. You need not go far. As the tree goes over, watch the top for widowmakers that might fall on you.

If the tree you are felling becomes lodged in another one, don't lose your head and try something foolhardy, or use a lot of time and energy unnecessarily. Even the best of fellers sometimes lodge a tree.

First, study the situation carefully. Size up how firmly the tree is lodged. If it is not lodged too firmly—for example, just caught in the ends of the limbs of another tree—you may be able to push it out or roll it out with the aid of a peavy. If not, maybe you can jar it loose by dropping another tree across the stem (about halfway up). More solidly lodged trees need to be pulled out. If the felled tree is not too big, it can sometimes be pulled back by hand, or pried back with a lever or pry pole (fig. 59). Solidly lodged big trees sometimes have to be pulled loose with a tractor or a team of horses.



Figure 59.—Prying the butt back sometimes frees a lodged tree.

LIMBING

Most limbing can be done with an ax. Of course big limbs, particularly on hardwoods, can be cut more easily with a crosscut or a power saw; but it is a waste of time and effort to use these big tools on small limbs.

Limbs are most easily cut by an ax stroke parallel to the tree stem, working from the base of the tree upward. If possible, you should stand on the opposite side of the stem, and chop away from you (fig. 60). Avoid standing on the stem of the tree whenever possible, and never stand on it while another crew is bucking anywhere along it. The stem may drop or roll when you least expect it to do so.

Train yourself to limb closely and smoothly. Projecting stubs will make the logs and bolts more difficult and more dangerous to skid and to handle; they complicate peeling, if that is to be done; and buyers of forest products discriminate against poorly limbed material.

During the limbing operation, you may occasionally have to clear away a small sapling that has been bowed over and pinned down by a fallen tree. First, try to pull the top of the sapling from under the felled tree. If you cannot do this, you may have to cut the sapling. Be careful about this. A bent-over tree is like a spring, and if you cut one end, it will spring out; and loggers have been known to get broken jaws by being in the way. A light creasing stroke at the top of the bow is best; it may allow the fibers to part, thus releasing the tension. If you cut the sapling off at either

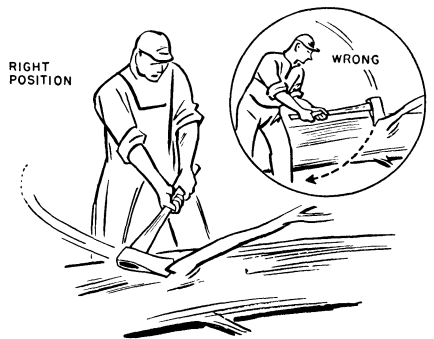

Figure 60.—Right and wrong positions for limbing.

end, be careful to chop from inside the bow, and stand back out of the way when the sapling springs loose.

BUCKING

Choice of Location

Bucking (cutting the tree into logs or bolts) can be done either in the woods or at the landing. If you are cutting big trees, you will probably buck them into logs in the woods and then skid the logs out. However, if you are cutting smaller trees, of the sizes now being cut in many woodlots across the Nation, there is no reason why you cannot skid the whole tree length to a landing and buck it there. One horse or a wheel tractor can easily handle tree lengths of most second-growth softwoods and hardwoods, even by ground-skidding.

Tree-length skidding is advisable in second growth if it is carefully done. It can be done with a minimum of damage to the woods where directional felling and careful tractor operation are practiced, even in light individual tree-selection cuttings and in dense stands.

For bucking at the landing, put the tree stems on skids, so that they will be off the ground. As a result the cutting is easier and the saw is kept from hitting dirt and rocks. Moreover, you will have a better chance to study the tree stem and to make the cuts accurately and at places that will produce the best logs and bolts.

Small Trees

For bucking small trees by hand, either in the woods or at a landing, the bow saw is excellent (fig. 61). It cuts fast and clean, and is easy to use.

Of course, much bucking of small material is now done with one-man chain saws. Bow-type frames are available for these saws. Within their capacities (generally 14, 18, or



F-448782

Figure 61.—Bucking at a landing with a bow saw. Notice the skids, which keep the tree stem off the ground.

24 inches) these saws are especially good for bucking because the chain is carried around outside the cut on its return trip to the motor sprocket, and the narrow, tapered guide bar for the cutting portion of the chain practically eliminates pinching.

However, the ordinary beaver-tail guide bar is the most common. These guide bars are made narrower in the newer models of saws, and the narrow guide bars are very handy in bucking. With them you can make upside-down cuts.

For cutting pulpwood to standard lengths, many loggers attach a measuring rod to the chain saw (fig. 62).



Figure 62.—With a measuring rod attached to the chain saw, measure while cutting.

This rod can be a telescoping automobile-radio antenna (usually available at a junkyard). Bolt it onto the saw with a swiveling bracket so that you can swing it at right angles to the saw blade. With this device you can measure as you cut.

When a tree is to be bucked in the woods, it is wise to measure and mark the bolt lengths on the entire stem (fig. 63), and then decide which is the best place to start cutting so as to avoid pinching or sawing into the ground. Sometimes it is advisable to leave the limbs under the tree uncut until after bucking, to keep the stem off the ground and to reduce swaying or rolling.

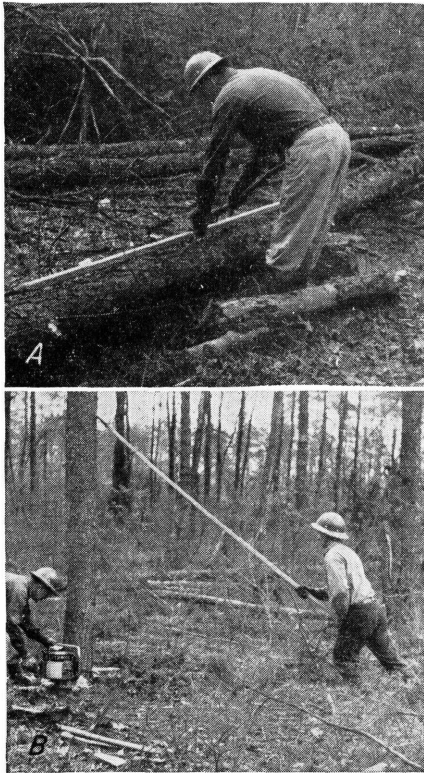

Figure 63.—A measuring pole is handy in bucking: A, Using a measuring pole to mark off the cuts; B, using the measuring pole as a pusher in felling small trees. Notice the spike on the end of the pole.

A bucking ladder (fig. 64) is of assistance when small stems are bucked at a landing. This ladder consists of a set of cross skids on which the tree lengths can be rolled. When you are cutting standard lengths, such as 4- or 5-foot bolts for pulpwood, you can place the skids exactly these distances apart. Each cut in the stem is made beside a skid, giving a rough measurement of bolt length, and eliminating almost all possibility of pinching. The bucking ladder also eliminates the chance of sawing into the ground, and permits cutting conveniently at waist height. The cut lengths still have to be picked up and carried to a pile.

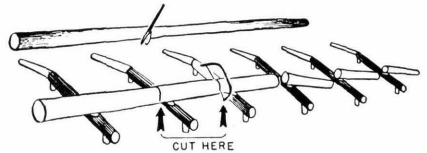

Figure 64.—A bucking ladder for cutting pulpwood.

A bucking chute (fig. 65) is somewhat more convenient than the ladder. The chute is most frequently made of a set of concave rollers, and has a device for advancing the pole for the next cut, such as a geared crank on one of the front rollers. The advantage of this arrangement is that all the cut sticks fall off at the same point. This makes it convenient to load them onto a truck, especially if a powered conveyor is used.

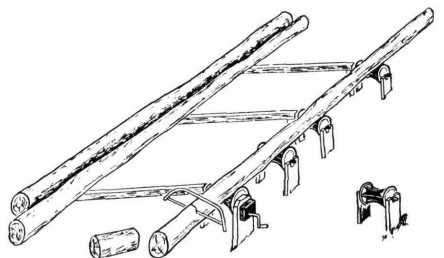

Figure 65.—A bucking chute. A hand crank is used to move the tree stem between cuts.

Large Trees

Bucking large trees calls for harder and more careful work than is necessary for small trees. There is usually a choice of lengths into which trees may be cut. Standard sawlog lengths usually run from 8 to 16 feet, by 2-foot intervals. Special lengths, such as 8½ feet for railroad ties and 17 feet for switch ties, are important in some localities. Generally the longer logs bring higher prices. Sometimes there is a market for logs longer than 16 feet for barn timbers or other specialty uses, which bring even higher prices. The farmer-logger should familiarize himself with local markets and their specifications; then he should cut his trees in such a way that he will get the best price for them.

However, there are other characteristics besides length to consider when cutting a tree stem into sawlogs. Generally buyers deduct for sweep, crook, and rotten places that reduce the useful content of the log. Consequently logs should be as straight and sound as possible. Often the effect of crooks can be reduced by making a cut at the point of greatest crook and reasonably straight logs will be left on either side. Surface injuries, such as old fire scars or wounds, will be less serious if they are at the butt of the log, where they will come off in the slab. Badly rotted sections can be cut out and left in the woods. Where crotches occur, the cut should be made below the point of forking so that there is no included bark left in the end of the log; and if there are logs above the crotch, the butt of each should be cut just above the fork, so that as little wood as possible is wasted.

More and more mills throughout the country are buying their logs by grade. Selling by grade gives a farmer who has good logs a price

advantage in marketing the products of his woodlot. It is advisable to find out if any mill in your neighborhood is buying on this basis. Learn what their specifications are, and then plan your cutting to produce the highest grade material.

Log lengths should be measured accurately, with an allowance for trimming. Ordinarily at least 3 inches on each log is required for squaring up the boards and removing checked ends. It is helpful to have this trimming allowance measured off on the butt end of your measuring stick. In this way the trimming allowance will be automatically provided for on each log.

In bucking large trees in the woods, you cannot switch the tree stem around as you can smaller material. But sometimes, when the logical place to cut is alongside a rock or hummock where it would be impossible to saw, you can cut the next higher length first, and then move the long log into a better position with pry poles or a peavy. When bucking on a hillside, guard against the log's rolling down onto the buckler on the downhill side. A block placed under or alongside the length to be cut off will usually prevent rolling. Buck from the uphill side wherever possible.

When you buck a suspended tree stem, slant the cut inward a little toward the supported side, so that the cut log will fall clear of the cut (fig. 66). If you slant the cut the other way, the cut log is almost sure to bind and to trap your saw blade in the cut.

Bucking suspended tree lengths is much easier if a one-man chain saw is used. Since you can use the saw on either side of the log, you can work with greater ease alongside a rock or hummock. On a slope, you can always saw from the safe, uphill side of the log.

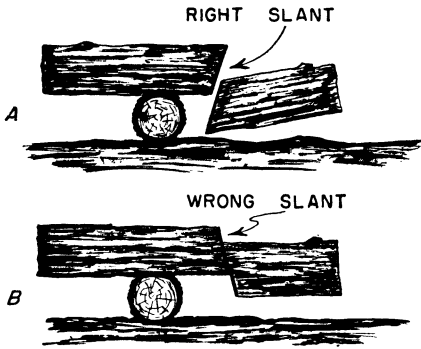

Figure 66.—A, Slanting the cut so that the cut log will fall clear; B, if the cut is slanted the wrong way, the cut log will pinch down on the cut.

When a long length is suspended at both ends, a cut made straight down from the top is sure to pinch. Instead start with a boring cut by holding the saw upside down at an angle to the face of the log (fig. 67). If the saw is held in this way, it will not kick

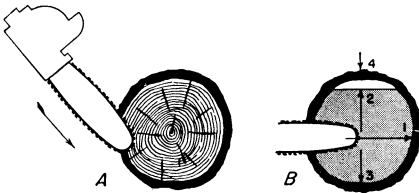

Figure 67.—A boring cut: A, Starting the cut, with the chain saw upside down so the saw will not kick out of the cut; B, completing the boring cut.

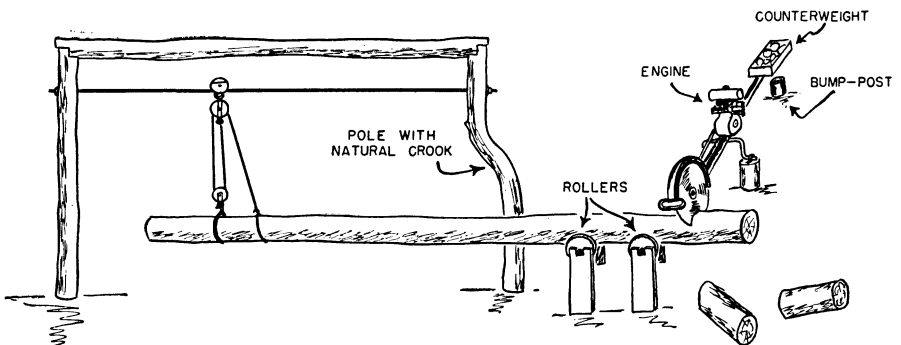

Figure 68.—One method of cutting tree lengths into pulpwood sticks.

out of the cut. When the saw is firmly in the cut, you can bring it horizontal and bore straight through the log. Then you cut upward, leaving a few inches of wood to hold at the top; next, cut down through the log; and last of all, cut the holding strip from the top. Boring cuts are possible with most of the modern saws equipped with router or chisel teeth.

Use of Power Saws

The rocking-table buzz saw for cutting short bolts into fuelwood is well known to almost every farmer. Thousands of these rigs have been constructed on farms throughout the country, run by gasoline engines or electric motors, and set on wooden frames. Mandrels and saws are available at almost any hardware store or mail-order house. Complete machines can be bought readymade, with steel frames; some are designed to be powered by a farm tractor or by the jacked-up rear wheel of an automobile; some come with motors attached.

The rocking-table feed is ideal for cutting 4-foot bolts into 16-inch lengths for fuelwood. Most 4-foot bolts can be handled easily by one man.

However, many farmers find that it is more efficient to bring in long sticks from the woods and to rig up a buzz saw to handle them. The arrangement usually includes a system of rollers or

supports to hold the stick for cutting and to move it into position between cuts (fig. 68). Tree-lengths can be handled with such arrangements.

The same kind of device can be used for cutting long poles into 4- or 5-foot pulpwood bolts or into short blocks for the charcoal industry. More elaborate devices can be made with powered rollers to advance the pole between cuts, and a small buggy on tracks to support the rear end of the pole.

SKIDDING

Skidding With Horses

Horses are still the most popular motive power for skidding small timber in many parts of the United States. Horses are especially good for work in second-growth stands, such as are being cut for pulpwood. Trained woods horses and competent teamsters are still available. Frequently the horse becomes so familiar with his job and the spoken commands of his teamster that he works without reins, positioning himself for the log to be hooked on, going down the skid trail by himself, and stopping at the correct place on the landing (fig. 69).

Skidding in rough, rocky, and brushy woodlands is difficult work for a horse not used to it. In ground-skidding especially, the load has a tendency to switch around unexpectedly, and the uneven footing and presence of obstacles make it a poor place for a young and skittish horse. Working with such a horse may also be dangerous for the woods crew. A medium-heavy horse (about 1,500 pounds) about 5 years old is preferred for woods work on commercial jobs.

The harness for a woods horse to be used in skidding should be properly fitted and of good quality (fig. 70). "Haywire logger," a term of contempt throughout the United States, was



Figure 69.—A woods horse can be trained to skid logs by himself. (Courtesy Maine Extension Service.)

originally applied to the logger who habitually repaired his harness with haywire, which not only ripped out and caused delays, but also injured the horse.

The whiffletree or singletree used for horse-skidding (fig. 71) should be long enough to hold the trace chains away from the horse's heels. A pinery hook at either end is used for attaching the trace chains; these hooks make it easy to lengthen the chains for the return trip to the woods, and to shorten them in hooking up to get some lifting action on the front end of the load. The whiffletree should be fitted with a grab hook on a swivel at the center, for attaching the skidding chain. A lifting ring attached to this grab hook will help to eliminate the risk of pinched fingers in hooking up the load.

Ground-skidding of small poles is usually done with a chain. A chain of $\frac{1}{4}$ - or $\frac{3}{8}$ -inch steel links, 10 or 12 feet long, and with a slip hook at one end, is ordinarily used. The chain can be wrapped around a single large pole, or two or more smaller poles, using the hitches illustrated in figures 72 and 73.

For ground-skidding bigger logs a chain can also be used, but skidding tongs (fig. 74) are sometimes preferred

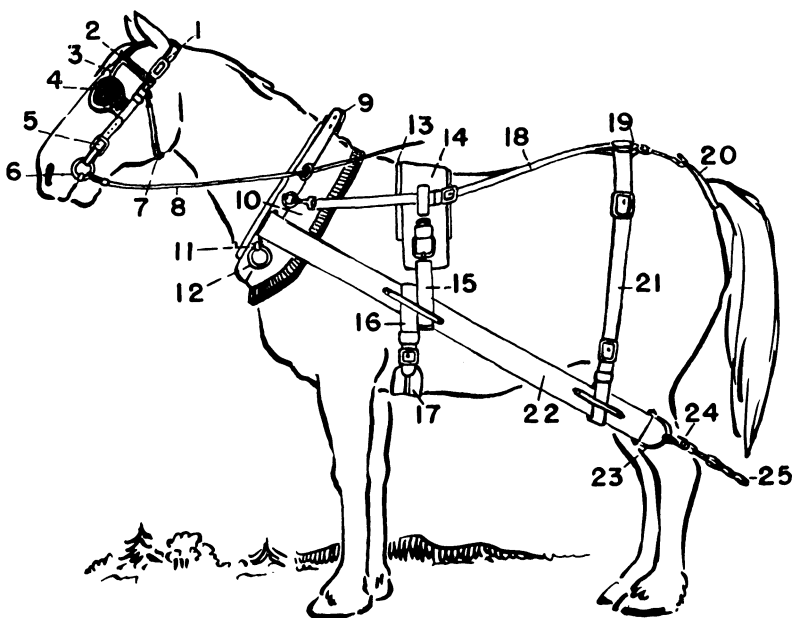

SKIDDING HARNESS

1-Crown	12-Lower Hame Ring	22-Straight Trace
2-Front	13-Back-Pad Felt	23-Dee with Detachable Bolt
3-Winker Stay	14-Back Pad	24-Pinery Hook
4-Blind	15-Back-Pad Billet	25-Heel Chain
5-Cheek	16-Belly-Band Billet	
6-Bit	17-Belly Band	
7-Throat Latch	18-Back Strap	
8-Reins	19-Breeching Centre	
9-Hame	20-Crupper	
10-Collar	21-Combined Hip Strap and Trace Bearer	
11-Bolt Draught		

Figure 70.—Skidding harness for a single horse.

because they do not add to the friction of the logs on the ground. You can buy tongs large enough for logs up to 60 inches in diameter. Log grabs, connected by short pieces of chain, are also used for ground-skidding logs in tandem (fig. 75). An auxiliary tool called a grab skipper (fig. 76) is used, both to pound the grabs into the log and to knock them loose. Skidding with log grabs is a common practice in the southern Appalachian

Mountains (fig. 77) and in the Rockies. Log grabs do ruin some of the wood at the ends of the logs.

To reduce friction, a device of some kind is frequently put under the log. Three types of sleds have already been described. These sleds make the use of a horse more economical for skidding longer distances over reasonably good terrain. For short skids or really rough country, ground-skidding is usually best and safest.

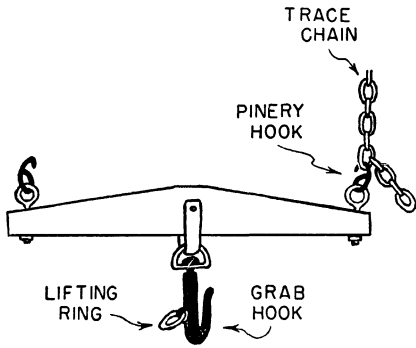
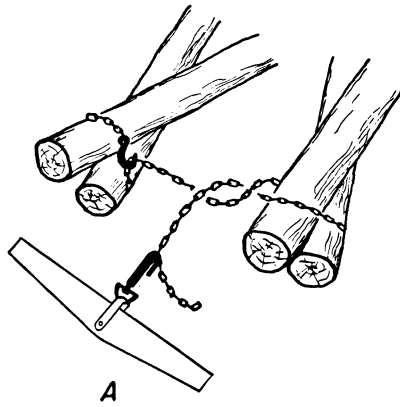

Figure 71.—Whiffletree for a logging horse.



A

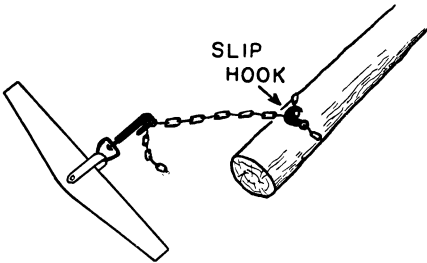
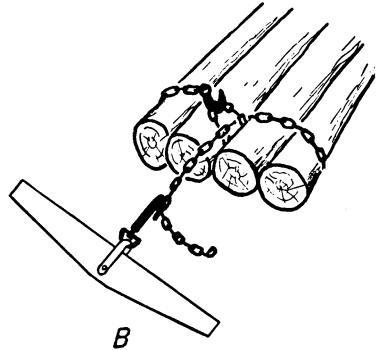

Figure 72.—Chain hitch for skidding one big log or two or three small logs.



B

Figure 73.—A, Chain hitch for two big logs or several small logs; B, the same hitch pulled tight.

Skidding With Tractors

A tractor is generally cheaper than horses for skidding logs more than 200 or 300 yards. For distances up to about 500 yards a tractor is often used without any antifriction device, since the gain in maneuverability usually offsets the cost of the extra power expended. But for skidding longer distances some sort of sled, pan, or sulky is likely to be more economical.

The special equipment that can be used with tractors makes them versatile machines for skidding. Such equipment includes hydraulic-lift drawbars, winches, sleds, skidding pans, and sulkies. The hydraulic-lift drawbar, which many farmers already have on their tractors, is an excellent skidding device in reasonably level, open woodlands where the tractor can be driven to each log

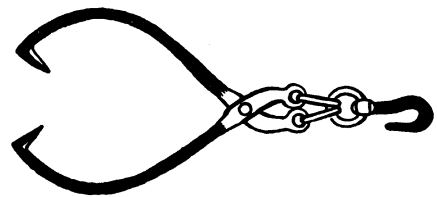

Figure 74.—Skidding tongs.

without difficulty. If a few of the logs are in places where the tractor cannot go, they can be pulled with a chain or cable to a place where they can be picked up at the drawbar.

A winch (fig. 78) adds tremendously to the usability of a tractor in the woods. The cable can be unwound from the winch for a distance of 75 feet or more, and attached to logs

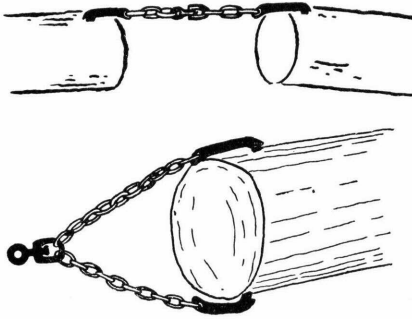

Figure 75.—Use of log grabs for skidding heavy logs.

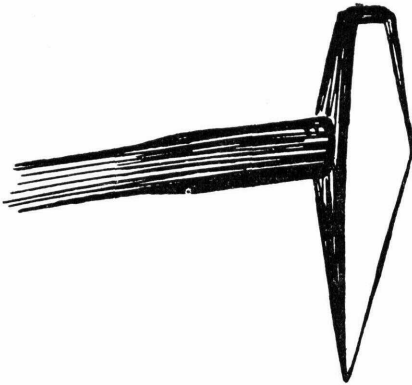

Figure 76.—The grab skipper.

located down a slope or in a boggy or rocky place. The logs can then be pulled out with the winch—and with greater power than is available at the drawbar itself. When pulling logs in this manner it may sometimes be necessary to chain the front of the tractor to a tree or stump to prevent its being pulled backward.

On the way to the landing, if you encounter an uphill slope or mud where the tractor cannot pull the load, you can put the winch into free-spooling and drive the tractor ahead to solid ground; then you can winch the load through the bad footing and go on in the normal way.

It is essential that the tractor winch have a powerful and a positive brake if it is to be used for skidding. This brake is most important with



F-468448

Figure 77.—Skidding with log grabs in the southern Appalachian Mountains.

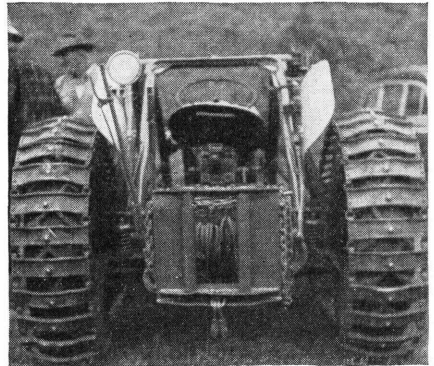

Figure 78.—A wheel tractor fitted with crawler tracks and a winch for logging. Notice the built-in fairlead rollers on the winch.

the straight-gear type. The worm-gear winch is much slower, does not have free-spooling, and heats up when in steady use; but it locks more positively for pulling.

For skidding longer distances (more than 500 yards), the tractor-winch-sulky combination (fig. 79) is most efficient. The lifting action of the dragline cable makes assembling a load easier. With a sulky a tractor can haul a bigger load, and the logs skidded this way are cleaner.

For this kind of logging, the direction in which the trees are felled is important. They should be felled as



F-457275

Figure 79.—Skidding with tractor and sulky.
A sulky lifts the front ends of the logs off the ground.

nearly as possible toward the direction in which they will be pulled out—within 45° . The logs then can be bunched more easily, and less damage is done to the trees left for future harvests.

For hitching logs when skidding with tractor and sulky—and for much ground-skidding and pan-skidding—a logging chain or choker is best. A choker is a short length of wire rope with hooks on both ends, or with a ferrule or clevis on one end and a hook or an eye on the other. A special type of choker hook (Bardon) is made for use with wire rope (fig. 80). The ferrule at the end of the choker provides a swiveling action that reduces the chance of ruining the rope by kinking it. Once seated in its recess in the hook, it has almost no chance of coming loose.

Completely made-up chokers, or the parts to make them, are available from most tractor dealers, especially those who handle the major makes of crawler tractors. Attaching the ferrules to the wire rope ends is relatively simple but must be done properly or the ferrules will not hold. Use

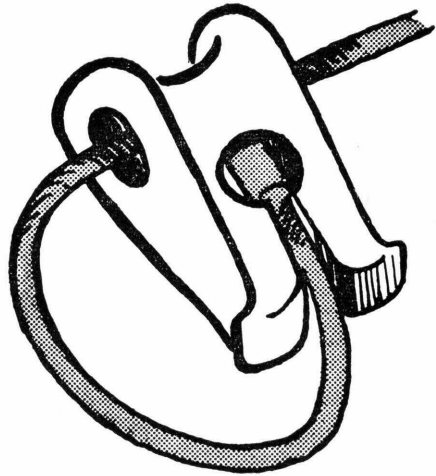

Figure 80.—The Bardon choker hook.

pure zinc or special socketing alloy; babbitt or lead will not do. The end of the rope should be completely unlaid to form a brush inside the ferrule. Simple instructions for doing this job can be had from all major wire rope manufacturers, and from the manufacturers of fittings.

Do not depend on clips or knots to hold the wire rope fittings. Neither clips nor knots will develop more than about 60 percent of the rope strength, and consequently they are dangerous to work with.

For logging with scoots, many northeastern loggers are installing winches and booms on their tractors to assist in bunching and loading the logs. Some of these scoot-loaders are homemade, with wooden or steel booms, and some are made by local tractor dealers or in machine shops. A scoot-loader developed by a logger at Great Barrington, Mass., uses a wooden boom with a hemp rope dragline and a winch with gypsy drums. It is fine for one-man operation. These rigs commonly use timber tongs to grab the log. Most of them are effective in bunching loads over a

radius of 60 feet, or even more. The use of power in loading prevents many a back strain and rupture—and it speeds up the job.

LOADING

Loading Small Wood by Hand

Throughout the country much of the pulpwood, millwood, and fuelwood is still loaded by hand, stick by stick. Often the teamster loads his own wood on the sled or dray in the woods, and then unloads it and ricks it again at the roadside. Sometimes he has help at both points, more often not. The time it takes to do this job varies greatly, depending on the size and shape of the sticks, the distance he has to walk, and his own skill and strength. A pulp hook is of great assistance in this work.

The wood is then usually reloaded onto a truck at the roadside; later it may be reloaded onto a railroad car for shipment to the mill.

In some localities trucks can be driven directly to the ricks or pens of wood in the forest; thus draying or skidding is eliminated entirely.

Loading Small Wood by Machine

A powered conveyor is of great assistance in various loading and re-loading jobs. The typical conveyor is basically a simple metal trough with an open bottom, in which a link chain with lugs travels. Small conveyor units, suitable for carrying pulpwood bolts from the ground up over the side racks of a truck, are now available, complete with gasoline engine for about \$400. Weighing about 300 pounds, they can be handled easily by two men. Many farmer-loggers have rigged up their own conveyors, using wood for the frame and gasoline engines they happen to have, and buying

only a bit of shafting, some sprockets, and link chain.

Small wood is also being loaded more and more in bundles or on pallets—especially when several re-loadings are necessary. Some purchasers require the farmer to stack his wood on tubular steel pallets, which they provide so that a self-loading truck can pull them aboard. Others require that the wood be piled in small units so that a cable sling can be passed around the pile, to lift it aboard the truck in a unit.

Loading Logs and Poles by Hand

Logs and poles are generally too heavy to lift by hand (although some small logs are loaded in this way). The simplest way to load logs is to roll them onto a truck. In hilly country a skidway built to truckbed height makes this job fairly easy (fig. 81). You will need a pair of sturdy skids between the truckbed and the skidway, and a plank as a walkway for the log roller. A cant hook or peavy is used to roll the logs.



F-408102

Figure 81.—Loading logs from a skidway.

Instead of a skidway, you may be able to use a roadbank and movable skids for the same purpose.

Rolling logs up onto the truckbed from level ground is more difficult. Usually this calls for at least two men, so that one can hold the log from rolling back while the other is getting a fresh grip with his cant hook or peavy.

To help keep the logs from rolling back you can use skids with spikes protruding from them or notches cut into them at regular intervals.

Log-Loading Devices

The simplest mechanical way to load is by using a crosshaul (fig. 82). The ends of a piece of cable (or chain) are attached to the truck bunks, then the middle section of the cable is brought down, passed under the log and back over the log and truckbed to the tractor, horses, or winch. When the cable is pulled, it hauls the log up the skids and onto the truck.

The A-frame jammer (fig. 83) is another traditional method of loading logs onto a truck. This jammer is a sturdy timber structure in the form of an A, often mounted on a sled frame so that it can be dragged from place to place in the woods. A sheave is hung in the apex of the A, and another at the base. A cable is passed through

the sheave at the base, and then up and over the one at the apex. Usually a crotch line and end dogs are attached at the end of the cable. The end dogs are seated in each end of the log to be loaded; when power is applied the log is pulled up and over the truck to its place on the load. The source of power may be a team of horses, a tractor, or a winch.

Another good method of loading, particularly when a considerable volume is to be loaded at one place, is to erect a gin pole (fig. 84). The boom, which may be a sturdy wooden pole, is attached by a swivel to the base of a planted mast or a standing tree. The top of the boom is held a given distance from the mast by a cable or chain. Again a sheave is hung at the top of the boom and another at the base to carry the cable. The usual method of handling logs with this device is by means of timber tongs. Generally the tongs are attached by a man on the ground, at about the

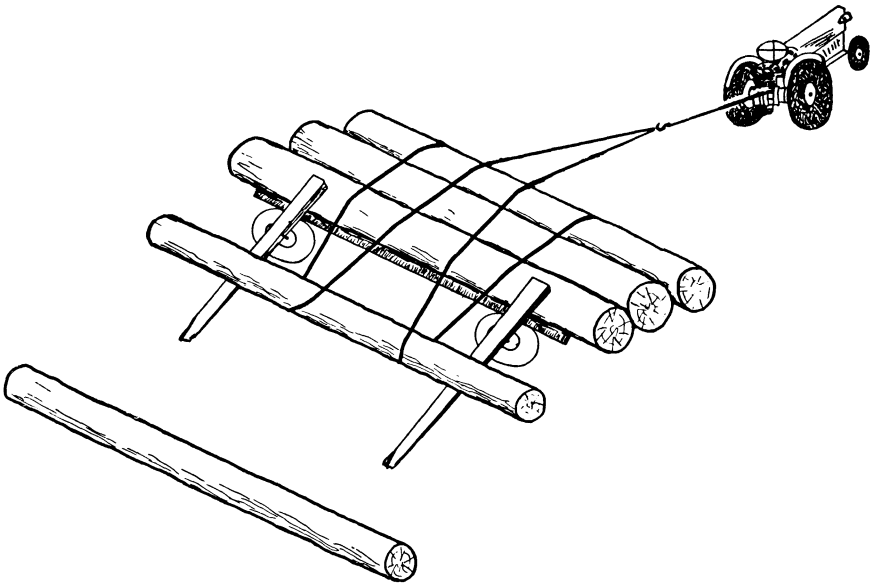

Figure 82.—Loading logs with a crosshaul.



F-442684

Figure 83.—An A-frame jammer can be homemade.

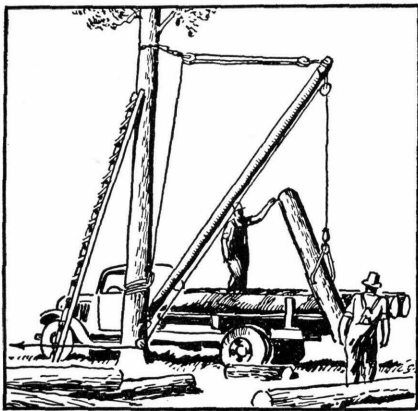

Figure 84.—The gin-pole loader swivels around.

center of gravity of the log. Then the log is lifted slowly while the ground loader pushes it around into position, and it is lowered onto its place on the truck.

These three simple loaders and various adaptations of them are used under

different conditions. The crosshaul is generally used for scattered logs, because it is the most portable. The A-frame jammer, which is somewhat less portable, is used when many logs are to be loaded at one place. The gin pole, which takes considerable time to rig, is ordinarily used when loading is to be done at one place over a considerable length of time. This method of loading is the best of the three for long pieces, such as poles and piling.

Self-loading trucks are coming into commercial use more and more. Very rarely will the farmer be justified in acquiring or making one of these devices. However, wood-using industries and their contract haulers are using them on "milk-route" systems of picking up forest products brought to the roadside by farmers and other small operators. These self-loading devices include: A truck equipped with its own crosshaul, by means of a winch installed under the bed; a "timber tosser" (fig. 85), which uses a pair of swinging arms to pick up the log and toss it onto the truck; and trucks equipped with their own jib-boom cranes, on a mast behind the cab (fig. 86), to lift the logs and swing them into position. Trucks equipped with such devices are making it possible for the farmer to sell small lots of logs at the roadside,



F-450144

Figure 85.—The "timber tosser" flips logs up onto the truck.



F-450467

Figure 86.—A self-loading truck.

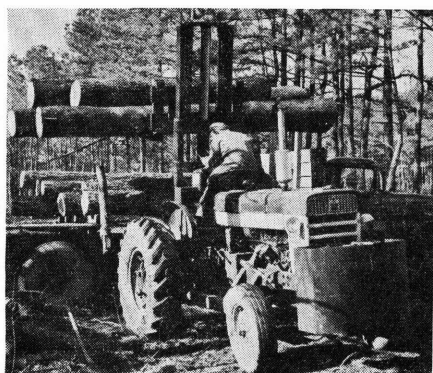

Figure 86a.—Loading logs with forklift mounted on rear of ordinary farm tractor. Note counterbalance at front of tractor.

which saves him the work of loading and hauling them himself.

In recent years many farmers have found that the hydraulic-lift forks used on the front of the wheel tractor for handling manure can easily be converted into a good device for loading wood (fig. 86a).

HAULING

The ordinary flat-bed truck can be readily equipped to haul a variety of forest products. The farm wagon is also satisfactory for hauling small quantities of logs or wood short distances. Even when a farmer sells the major products of his woodlot at

the roadside, he may frequently want to haul a few logs to a sawmill for custom sawing, or some fuelwood or other material for use on the home place. Stake racks for hauling fuelwood and fence posts are often available for the farm truck.

Be careful not to overload your vehicle, particularly if you must travel over rough roads. A cord of green hardwood—a deceptively small pile—can weigh $2\frac{1}{2}$ tons. With such a load it is easy to break a spring or axle on a farm truck.

If logs are to be carried on a flat-bed truck, it is a good idea to put wooden or steel bunks across the bed (fig. 87). These bunks will give a firmer support to crooked and knotty logs, and will save a lot of wear and tear on the truck bed. Stakes can be installed in the ends of the bunks to help hold the load. However, if the truck is to travel on a public highway, most



F-440874

Figure 87.—Flat-bed truck with log-carrying bunks.

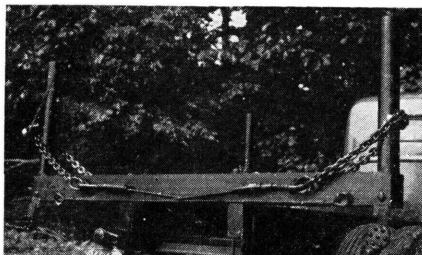

F-445477

Figure 88.—Safety tripping stakes on a log truck. The stakes on one side of the truck can be released from the other side.

States now require that the load be cinched tightly with at least two wrapper chains or cable. Safety trip-stakes, which can be released from the opposite side of the truck, facilitate unloading and make the operation much safer than it would be without them (fig. 88). A number of different types of tripping devices are used on these stakes, some of which can be easily made at home. In New York State such safety tripping devices are now required on all trucks carrying more than 500 board-feet of logs on the public highways.

Loads of logs are also very heavy. A thousand board-feet of green hardwood logs will frequently weigh 10,000 pounds, and softwood logs will frequently tip the scales at 7,000 pounds or more per thousand. Helper springs on the rear of the truck, or a set of bogie wheels that will come into use when the truck settles under the load, will often make it possible for the truck to carry a heavy load.

In addition to guarding against overloading your truck, it is also necessary to balance the load carefully when hauling a product as heavy as green wood. Many farm trucks have too short a wheelbase to carry long logs without having them hang over at the rear. Protruding logs are dangerous because they may reduce the weight carried by the front wheels and make steering difficult or impossible. On the other hand, the load should not be placed too far forward. This position puts too much weight on the front wheels, makes steering difficult, and may cause a blowout of a front tie. Generally trucks run best when about 25 percent of the weight of the load is on the front wheels. The remainder of the load, about 75 percent, should be balanced over the rear wheels.

The load should be balanced across the truck bed too. If it is not, the

truck may tip on a curve or slope and bend an axle or blow out a tire, sometimes even upsetting the whole load.

Tires should be in good condition, well matched (particularly on dual wheels), and evenly inflated. If one of the tires overheats, it is carrying too much weight. Tire pressures should be checked, and if they are even and a tire continues to overheat, a better matching of tire diameters should be made.

Trucks, like other equipment, are constantly being improved and require less and less attention; but all mechanical equipment works best and most economically if it is kept in good repair, and properly oiled and greased. The instructions of the manufacturer as to capacity and maintenance are not to be disregarded.

SUPPLEMENTARY MOTION PICTURES

EASIER WAYS OF LOGGING, a 26-minute motion picture in full color, shows safe, economical logging methods for small woodland owners. Requests for loan of this 16-mm. film (released in 1952) may be sent to the Forest Service, United States Department of Agriculture, Atlanta 5, Ga.; Upper Darby, Pa.; Milwaukee 3, Wis.; or Washington 25, D.C.

THE SMALL SAWMILL, a 20-minute motion picture in full color, shows how a mill operator improves the quality of lumber produced, increases mill efficiency, and lowers accident hazards. Requests for loan of this 16-mm. film (released in 1954) may be sent to the Forest Service, United States Department of Agriculture, Washington 25, D.C., or to any regional office of the Forest Service.

U. S. GOVERNMENT PRINTING OFFICE: 1962