

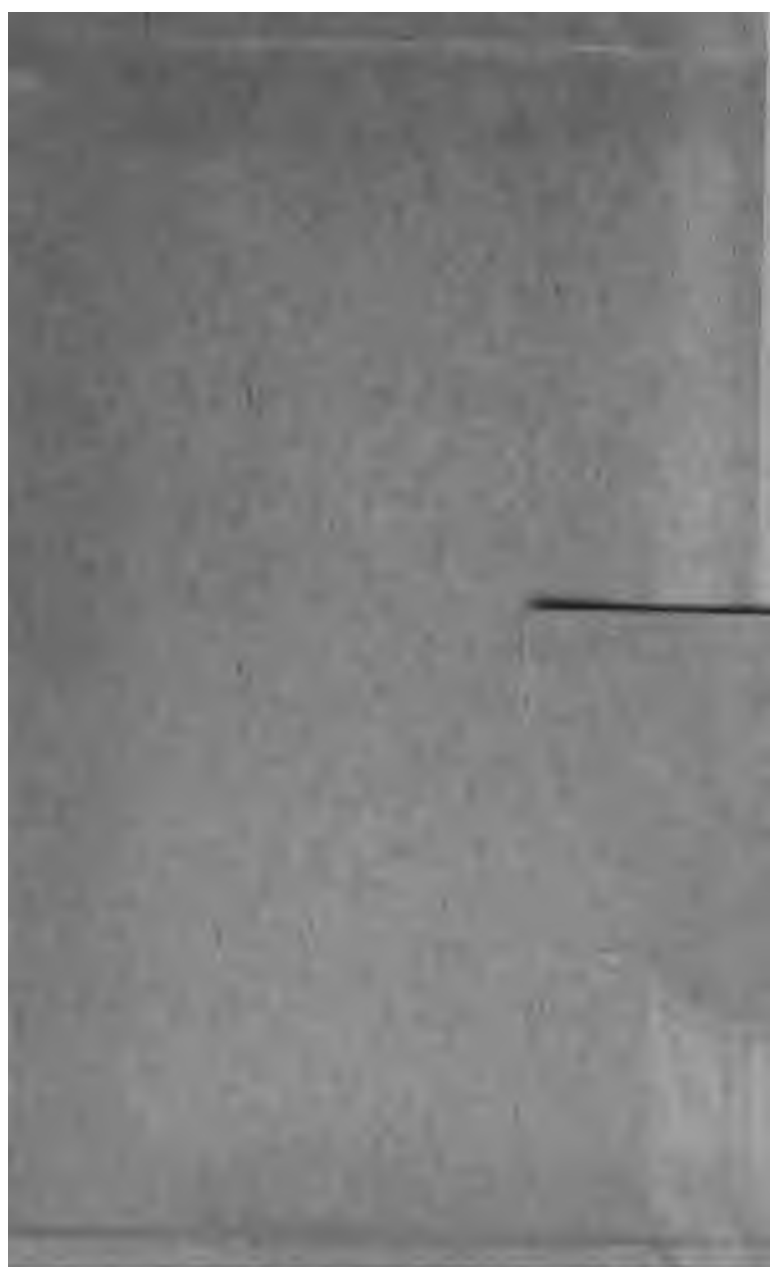

NYPL RESEARCH LIBRARIES



3433 06737422 7





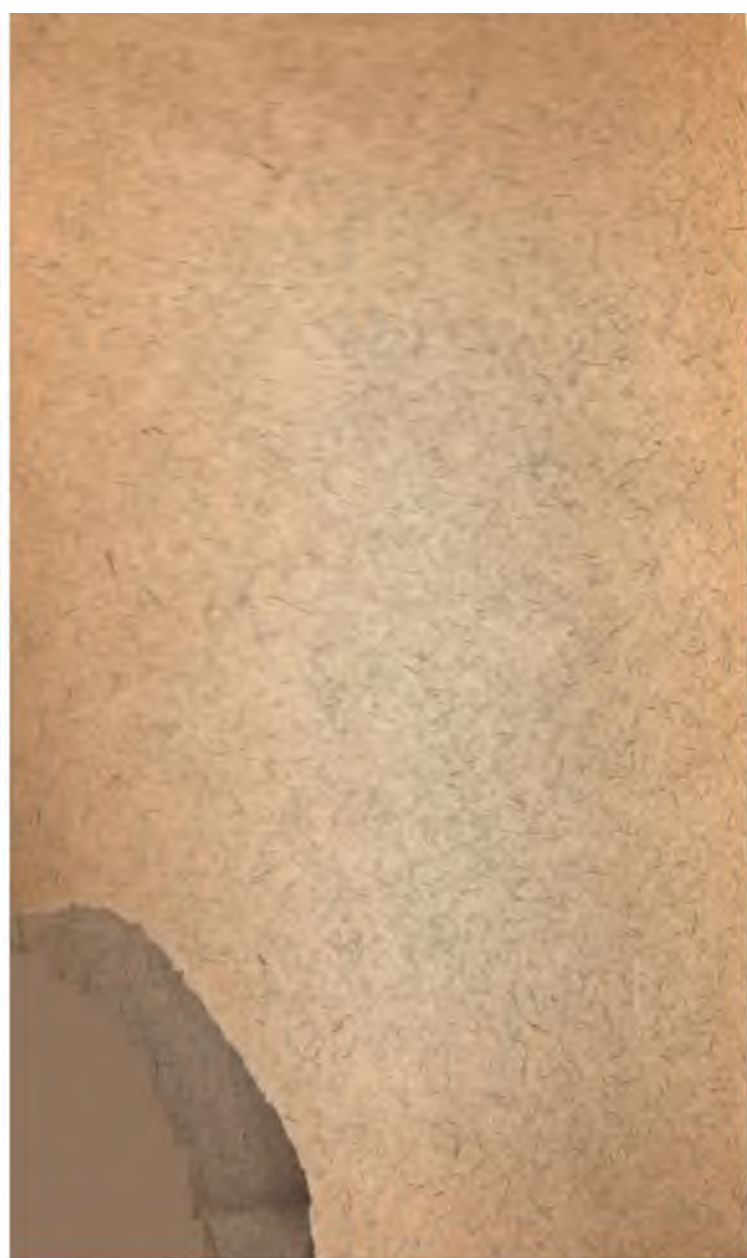





Gas March &
with the compliments
of the Author
Mich^l Pheasant

Pheasant



THE NEW YORK
PUBLIC LIBRARY.
ASTOR, LENOX AND
TILDEN FOUNDATIONS.



THE NEW YORK
PUBLIC LIBRARY.
ASTOR, LENOX AND
TILDEN FOUNDATIONS.



Fig. 1. H. G. Jackson, Jim Web

Michl. Pelan

THE
GAME OF BILLIARDS,

BY
MICHAEL PHELAN.

FOURTH EDITION:

REVISED, ENLARGED, AND RICHLY EMBELLISHED WITH ILLUSTRATIONS

NEW YORK:
D. APPLETON AND COMPANY,
346 & 348 BROADWAY.

1859.

SPB

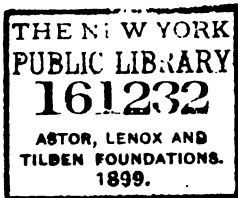

Entered according to Act of Congress, in the year 1888, by
H. W. COLLENDER,
In the Clerk's Office of the District Court of the United States, for the
Southern District of New York.

P R E F A C E
TO THE
T H I R D E D I T I O N .

THE ready sale and general favor which two former Editions of this work have met with, would seem to render any preface to this present issue unnecessary, except for the purpose of allowing the Author to express his heart-felt thanks to his numerous friends and the public generally, for their kindness.

Nevertheless, he is well aware that some points in the book, as at first published, though clear enough to himself, or any others who were adepts in the game, must have seemed difficult of comprehension, both to beginners and players in other parts of the country, not acquainted with the technical terms made use of in the billiard-playing circles of our larger cities. These deficiencies are here remedied with the utmost care; and the whole text has been revised and enlarged where requisite, under the light of all suggestions made by critics or friends, and to supply such rules as letters of enquiry proved to be not clear enough in their original form.

Making no pretensions to literature—a practical man, merely jotting down the results and observations of his own experience, the author deprecates any censure for the style of his performance; but where a fault can be pointed out in any statement relating either to the theory or practice of the game to which his life has been devoted,—in that case he will not have one word to urge against the most summary condemnation, but will feel grateful to the critic who has called attention to the error—if any such can be found.

Some irrelevant matters which haste permitted a place in the two former issues, have been excised from this; and in its present form the author again commits his venture to the public, assured that nothing has been neglected on his part to make the volume more worthy of the generous and cordial appreciation with which the two prior editions were received.

Very gratefully,

MICHAEL PHELAN,

'86 AND 788 BROADWAY, NEW YORK, 1858.

ORIGINAL PREFACE
TO FIRST AND SECOND EDITIONS.

SEVERAL years ago, the present author had prepared a collection of diagrams and notes, out of which it was his earnest desire to compile such an Essay on Billiards as might really promote the scientific development of the noble game.

But being at the time too closely engaged to devote the necessary amount of labor to such a production, the work fell short, in every way, of his just expectations—though he has heard from many good authorities that, “with all its imperfections on its head,” it was nevertheless the most complete and thorough manual that had previously been issued on the subject.

Apart from the friendly partiality of these critics, the author has since reviewed the work, with as little prejudice as the circumstances would permit; and he has found that although a majority of the principles, and nearly all the examples therein laid down, are correct—still, as a whole, the treatise lacks that systematic arrangement, in the absence of which it is impossible to arrive at scientific deductions by legitimate means. The thread of the argument is correct enough, but it needs to be unravelled: there are nearly all the materials for a fine building there, but the Scientific Edifice is still unfinished and unfurnished.

Now, at a time when kinder fortune has placed more leisure at his command, he has undertaken the present volume, with a serious desire to correct the inaccuracies and inadvertencies which disfigure his former essay. Whether successfully or not, he has devoted his best care, and the

whole teachings of his experience, to make this book a practical help and guide to every student of the game—whether that student be a mere novice, for the first time handling his cue, or a player of high standing, who has won matches where the billiard-fame of his country was at stake. It is the property of every science to be infinite ; and the best of us are but students, who can learn fresh lessons every hour, if our eyes are not blinded by the idea that we have already arrived at perfection.

In the diagrams which illustrate the text, he has confined himself to such positions as are best calculated to explain the essential principles of the game ; and has avoided those curious or “fancy shots,” as they are called, which, though of interest to the accomplished player, it is almost impossible to explain or render credible to the uninitiated, except by ocular demonstration.

The code of rules drawn up for simplifying and giving uniformity to the various games of billiards, as played in the United States, will be found, the author confidently believes, the most ample and satisfactory ever laid before the public.

Finally : in that portion of the treatise which is purely rudimentary—the quantities of motive power, the different kinds of stroke, and so forth—the present volume must necessarily have much in common with its predecessor ; but the similarity is rather superficial than exact, for even in these matters many points will now be found elucidated, which the haste and insufficiency of the former work left either vaguely or erroneously accounted for.

With these few remarks—made rather to anticipate attacks than to boast of what is here accomplished—the author would subscribe himself,

The public's most obedient servant,

MICHAEL PHELAN.

CONTENTS.

PREFACE		9
CHAPTER I		13
	Introductory and General—some account of the Origin of Billiards, and an Appeal to the Ladies of America in its favor, 13.	
CHAPTER II		29
	On the Machinery of Billiards—the Table and its Appurtenances—improvements in the Cue and Cushions—the Cue, 30. The Balls, 33. The Counters, Chalk, and Artificial Bridge, 34. A Billiard Room—its proper Dimensions—on the Arrangement of the Lights, 35. The Cushions, their Importance and Scientific Requirements, 36. Faultiness of India Rubber, and other Cushions—opinion of Edward Russell Mardon thereon, 38.	
CHAPTER III		42
	The General Principles of the Game defined, with a view to their Practical Application—conditions of a Good Attitude, 43. How to make the Natural Bridge, 45. The Lady's Attitude in Playing Billiards, 46. The Cue, its Weight, &c., 49. The Cue Leather, on the Selection of, 51.	

DIAGRAM No. XVIII.....	140
Further Illustration of Nursing or Managing the Balls.	
DIAGRAM No. XIX.....	144
Taking Advantage of the Chances for making Points.	
DIAGRAM No. XX.....	148
Some Fancy Shots in Common Use.—J. N. White's Favorite Shot, Fig. 4, same Diagram.	
DIAGRAM No. XXI.....	154
Advantages of the Perpendicular Stroke.	
DIAGRAM No. XXII.....	157
On Execution and Judgment.	
DIAGRAM No. XXIII.....	160
A Stroke from the "Billiard Cue."	
DIAGRAM No. XXIV.....	163
A Shot of Mr. C. Bird's.	
DIAGRAM No. XXV.....	166
Showing the Position of the different Spots on the Billiard Table—also the Semicircles or Playing Points for the English and French Games.	
CHAPTER V.....	169
A Code to Regulate and Reduce to Uniformity the different Games of Billiards, as Played in the United States and elsewhere.	
A CODE TO REGULATE THE AMERICAN OR FOUR-BALL GAME.....	172
On Stringing for the Lead, 172. On Leading, and on Opening of the Game, 173. On Foul Strokes, 173. On Forfeitures, 177. On Cases where the Balls are in Contact, 179. On Withdrawing from, without Finishing, a Game,	

CONTENTS.

ix

DIAGRAM No. VI.....	100
Further Illustration of the "Follow" and "Force."	
DIAGRAM No. VII.....	106
On Twisting Shots.	
DIAGRAM No. VIII.....	110
On the Effect the Side-Stroke will have on the Cue-Ball, after contact with the Cushion.	
DIAGRAM No. IX.....	113
Effect of the Side-Stroke and Twist continued.	
DIAGRAM No. X.....	117
Further Illustration of the Side-Stroke.	
DIAGRAM No. XI.....	119
Illustrations of the "Kiss" and Side-Stroke.	
DIAGRAM No. XII.....	122
Further Illustrations of the "Kiss" and Side-Stroke.	
DIAGRAM No. XIII.....	126
Further Illustrations of the "Kiss" and Force.	
DIAGRAM No. XIV.....	129
More of the "Kiss."	
DIAGRAM No. XV.....	132
Forming Curves by a Follow and a Force.	
DIAGRAM No. XVI.....	135
On Managing the Balls so as to leave good Breaks.	
DIAGRAM No. XVII.....	138
Another Illustration of Managing or "Nursing" the Balls.	

RULES FOR PIN POOL.....	220
As Played in New York.	
RULES OBSERVED IN PLAYING PIN POOL.....	226
At Michael's Billiard Rooms, in San Francisco.	
RULES FOR THE GAME OF ENGLISH POOL.....	232
RULES FOR POOL PLAYING AT THE LAST PLAYER.....	232
RULES FOR THE NEAREST BALL POOL.....	237
INSTRUCTIONS TO THE MARKER.....	239
For Keeping the American, or Four-Ball Game.	
CHAPTER VI.....	241
General Summary of Instructions. Conclusion.	
APPENDIX.....	247
IMPROVEMENTS IN THE BILLIARD TABLE.....	247
With Illustrations.	
THE ANGLES PRODUCED BY THE CLOTH, INDIA RUBBER AND COM- BINATION CUSHIONS.....	249
Illustrated by Diagram.	
FURTHER IMPROVEMENTS—PHELAN & COLLENDER'S PATENTS....	253
HUMOROUS ARTICLES.....	259
"ATTITUDE IS EVERYTHING".....	259
With Illustrations.	
SHAKESPEARE A BILLIARD PLAYER.....	265

THE GAME OF BILLIARDS.

CHAPTER I.

INTRODUCTORY AND GENERAL—SOME ACCOUNT OF THE ORIGIN OF BILLIARDS, AND AN APPEAL TO THE WIVES AND SISTERS OF AMERICA IN ITS FAVOR.

MAN does not live that he may work—at least he ought not so to live in a well-regulated condition of society. On the contrary, we should rather work that we may live; and whatever system of political economy does not embrace certain hours of relaxation, and certain methods of amusement, is a false and pernicious idolatry, having Mammon for its God, and man's best energies and happiness as the victims to be sacrificed upon its unholy altar.

There are two extremes of population, in which the sanitary needs of amusement stand a chance of being overlooked or crowded down by still sterner necessities.

Where the population is so dense as we find it in the manufacturing districts of England, not a moment can be spared from the incessant demands which competition makes on toil: labor is there so redundant that it loses its proper value, and nothing but the strictest

and most unremitting devotion to business can secure even the barest necessities of life. Where wealth is monopolized in the hands of a few, while the millions are forever hovering on the very brink of starvation, it would be absurd to look either for a general diffusion of intelligence, or for any system of amusement superior to that afforded by the gin-palace and the dog-fight.

Again, on the other hand, where the population is disproportionately small when compared with the vast resources which lie around it, in a new and undeveloped country—where wealth runs to waste on every hand for the want of labor to collect and garner it—where every man is free to become his own master and create a future for himself independent of any other help,—in such a condition of society toil rises to an unnatural importance; we reckon time not by hours, but by dollars; and hence it is we find, that in the earlier settlement of our country, the grim, puritanical spirit of the original immigrants not only discouraged “unprofitable amusements” by preaching and denunciation from the pulpit, but even went so far as to prohibit the most innocent recreations by positive and penal enactments.

How short-sighted such a policy! what ignorance of man's real nature is betrayed in this bigoted and narrow course! For the desire for amusement has been implanted in man, and in all other animals as well, as one of the primitive instincts, and for the most important purposes: it teaches us in childhood the use of our various faculties—it inspires us with ambition and dexterity, and helps to unfold the mind by bringing it into con-

tact and rivalry with the minds of kindred youth. In manhood it is the best promoter of bodily health, and enables us to sustain those serious toils which, if unrelieved by some more pleasing stimulant, would soon succeed in degrading us to the level of mere human machines.

Instead, therefore, of railing against the popular desire for amusement, true wisdom would rather seek to encourage the spirit, and direct it into such channels as would best promote the objects for the accomplishment of which we were endowed with it by nature; and true policy would suggest, that, instead of adopting the Roman plan, where the circuses, or public games, embraced the mortal struggles of the gladiators and the deadly contests between men and wild beasts, we should return, as much as possible, to the old Egyptian system, by which the public recreations were made the vehicle of imparting all the most important scientific truths, in a form so agreeable and simple, that the very meanest intellect was capable of appreciating and recollecting their cogency. Thus the original game of cards, as taught by the builders of the pyramids, conveyed a knowledge of the whole system of practical astronomy—the “court cards,” as we call them now, representing the different constellations which rule the year, and the numerals being marked in such a manner, as to indicate precisely the different periods for the overflow and subsidence of the Nile, and the various agricultural operations thereon dependent.

But cards have long since lost their character of primitive simplicity and instruction; they have degen-

erated to far different service; and, though still valuable, in some slight degree, for the arithmetical combinations which they illustrate, it is felt, in the first place, that their use is fraught with peril; and, in the second, that they are destitute of that bodily exercise, without which amusement ceases to be healthful.

Chess is indeed a splendid game, and may be called the tournament of intellects; it affords a field for the development of the very highest efforts of genius—its capacities are infinite, and, if worked out in a legitimate spirit, would form a mental discipline, not one whit inferior to the abstrusest propositions of mathematics. It is, in fact, so much of a discipline, that it almost ceases to be a game; it is exhaustive of the brain, and Sir Walter Scott declared, as his reason for abandoning chess (of which, like Napoleon, he had been passionately fond), that “the last game he played with Lockhart, his son-in-law, cost him more mental labor, and left his faculties more prostrate, than the composition of the best novel he had ever written.”

Chess, therefore, though an excellent exercise for the mind, is too rigorous and concentrated to be considered an amusement; it is merely an intellectual combat, which calls for no muscular energy, or physical accomplishment; it teaches neither quickness to the eye nor readiness to the hand; and its nature is so sedentary and intense, as to be absolutely prejudicial to health, if pursued to any great extent. But it possesses this advantage over cards—an advantage to which we wish to call particular attention—that its intrinsic intellectual excitement is so strong, as to render unnecessary the money inter-

est, or money bets, which are found, to a great extent, essential to the full enjoyment of the others.

Again, in the game of Bowling, we have great physical energy displayed, while the mind is left in almost utter inactivity. A certain physical knack is to be acquired, for the purpose of impelling a ball of a certain weight, to hit an object at a certain distance, in a certain way; but when once this difficulty is mastered, we exhaust the whole resources of the game. The physical exercise is often too severe, and there is not variety enough to afford a natural excitement—in the absence of which we are all too apt to apply ourselves to the money-interest of a bet, to make up for the deficiency which is inherent in the nature of the game.

From the preceding remarks—if we have caused our meaning to be understood—it will be seen that a game, to satisfy all the requirements and avoid all the dangers of a public amusement, should contain within itself the following indispensable prerequisites:

In the first place, it should exercise and discipline the faculties and resources, both of the mind and body, without exhausting or disgusting either; and,

In the second place, it should contain within itself sufficient mental excitement and ambition to render the extrinsic interest of a money bet superfluous to its full enjoyment.

These, as we understand the matter, are the two essential points to be consulted in the selection of a game to be adopted as a public and national amusement; and these we confidently affirm, and the experience of the world will support our assertion, are to be found

alone in their perfection in that which has worthily been styled

“THE NOBLE GAME OF BILLIARDS.”

This game is peculiarly in harmony with the mechanical genius of our people ; it combines science with gymnastics, teaching the eye to judge of distances, the mind to calculate forces, and the arm to execute with rapidity and skill whatever the mind and eye combine to dictate for its execution ; it expands the chest, while giving grace and elegance to the form,* and affords even to the illiterate mind a practical basis for the appreciation of mathematical and geometric truth. Already this game is the most popular in the thickly-settled parts of the country ; and there is a growing disposition to adopt it as one of the national characteristics. Thousands of our wealthiest and most intelligent citizens no longer consider their mansions complete without a billiard-room ; and when we con-

* According to the best opinion of anatomists, there are in the neighborhood of four hundred muscles in the human body ; and beauty of person, as well as health, will much depend upon each of these muscles being brought into action under proper circumstances, and to a suitable extent. Now, the game of Billiards calls into action each and every one of the sinews, tendons, joints and muscles of the frame, as any one who will take the trouble to watch a single game, must be satisfied for himself. In walking, striking, stretching, stooping, and leaning back, the requirements of an ordinary game place the player in almost every attitude that it is possible to conceive. To this testimony of our own senses, we could add that of the best medical authors, if we thought that such were needed to give weight to a proposition which demonstrates itself.

sider the sedentary habits into which our American ladies have lately fallen, we cannot fail to rejoice for their sakes, that their homes will henceforth be adorned with a means of recreation, which will pleasantly compel them to take the needful exercise, and, at the same time, so largely contribute to make home attractive to the sex upon whose presence their enjoyments to a great extent depend.

The origin of this delightful game, like the birth-place of Homer, is a contested point, and its antiquity, like that of many elderly spinsters, is involved in considerable doubt. By some it is supposed to have been imported from the Persians during the Consulship of the Roman Lucullus; by others, the honor of introducing it into Europe from the East, is assigned to the Emperor Caligula.

But be these things as they may, we have no authentic record of its existence, until the return of the Knights Templars to Europe, on the termination of the first crusade; so that, if known at all to the Romans, as is generally supposed, it must have perished along with many other noble arts on the overthrow of their empire; and unless the diggers at Herculaneum and Pompeii, bring us up the charred remains of a billiard-table, the matter must forever remain a subject of uncertain speculation.

In all probability, however, the game, like that of chess, has an eastern origin; the Templars brought it back with them from the Holy Land, and it soon became the favorite amusement and means of health to which the cloistered monks of that period were permit-

ted by their superiors to have recourse: and however much, in these latter days, it may have come to be regarded as a "carnal amusement," we have abundant evidence that it was cradled in the monasteries, which were then the fountain heads and only sources of the Christian faith.

Having been introduced into Europe by the Knights Templars, the game of billiards shared their fate; and when the power and wealth of that chivalric order tempted the cupidity, and prompted the jealousy of the European monarchs to their overthrow, the game disappeared along with the fortunes of its masters, nor was it again revived until the peaceful disposition of Louis XI. of France induced him to prefer its pleasant emulation to the bloody tournaments that were then the pastimes of his court.

By one of his successors, Henry III., it was still more widely patronized; and to that monarch it stands indebted for its appellation of "The noble game." The kings of France were, at all times, its most powerful and steadfast friends.

Again we find that the unfortunate Mary Stuart, Queen of Scots, complains in a letter to the Archbishop of Glasgow, dated Fotheringay, and written the very evening before her death, that her "Billiard table has just been taken away from her, as a preliminary step to her punishment." Doubtless, Mary having been married to the Dauphin of France, was introduced to the game during her stay in Paris.

You see, therefore, ladies, that you will run no risk being considered "too masculine in your tastes," if

you devote yourselves to this delightful household recreation ; for a woman, and a queen, whose misfortunes are only surpassed by the lustre of her accomplishments, has here set you, many centuries ago, an example of loving it with a fervor which even the near approach of death could not efface. No doubt also, Queen Elizabeth, who was chiefly emulous and jealous of her cousin's superior beauty and accomplishments, must have been a passionate votary of the game ; and in this manner only can we explain the anachronism which Shakspeare commits when he makes Cleopatra (Act II. scene 5) exclaim to Charmian, "Let us to billiards!"

Beyond question, this was one of the compliments to the whims and caprices of his mistress, with which the poet was in the habit of interlarding such compositions as he wished might find favor in her eyes. On this point, see a pleasant article, entitled "Shakspeare a Billiard Player," which will be found in Appendix.

Indeed, we have often thought that whoever would start a good calisthenic academy, with billiard tables, and other apparatus for the physical recreation of the gentler sex, would entitle himself to be looked upon as a public benefactor. The majority of complaints, consumption included, which afflict the female world, arise almost exclusively from the want of exercise, and suitable amusements. We are told so by the doctors, and we know it from our daily experience.

Now, the game of billiards, though a very gentle one, calls every muscle of the body into active life ; its attitudes are as diversified as the position of the balls

upon the board, and yet there is not one of them that is not fraught with easy gracefulness and vigor. In the ordinary course of an hour's billiard playing, a person will walk from two to three miles round the table, besides exerting every sinew of his body in other and different directions; and yet so frequent are the pauses, and so absorbing the interest, that the idea of fatigue is the very last that will enter the head.*

The grand feature which, we trust, will eventually lead to the general adoption of billiards, as the game for home—the game to be introduced into the houses, and shared with the families of all who are wealthy enough to afford such an inexpensive luxury—is this: that it will admit of being enjoyed in common by both the male and female members of the family or circle. Neither sex can enjoy an amusement so rationally, or innocently, when alone: for they exert a happy influence on each other when in company, and more than one half of the vices and follies which affect society, result from the separation of the sexes in the pursuit of their different amusements. Those giant plague-spots of society, as at present constituted, gambling and intemperance, seldom dare to show their features in the drawing-room,

* Exercise to be efficacious for good even in the healthy, must be excited, sustained, and directed by that nervous stimulant or odic force, as it is called, which gives the muscles the chief part of their strength, and contributes to the sustenance of the parts in a state of activity. In short, to obtain the full advantage of the nervous stimulus in exercise, we must be *interested* in what we are doing. Billiards supplies this excitement, and, therefore, it is, that the exercise which we take at the game is so particularly healthy.

while they often obtrude their unwelcome presence into places, from which ladies are excluded.

Look, ladies, at the billiard table as a means of domesticating your husbands and brothers—as a means of making home so agreeable that they will seldom care to leave it, except on business or in your society—and say, if the general introduction of the game as a household appendage be not worth your very serious consideration.

A first-class table, furnished with all the modern improvements, would cost much less than the price of a good piano; it would permit any number from two to ten to play on it at once with ease, and would

* We have often heard gentlemen regret that they could not have a billiard table in their own houses, on account of a prejudice which their wives entertained, that the game was connected with gambling. No illusion could be more baseless, or more prejudicial to the best interests of families: baseless, for the game is no more a gambling one than chess—its intellectual interest suffices without the unnatural stimulus of a bet; and the ladies might, with much more reason, object to the election of a President, because we know that large sums are constantly staked upon the success of the rival candidates. It is prejudicial, we add, because everything that makes home less agreeable to the head of a family, tends in so much to alienate him from that sphere in which his pleasures should be found. If the true domesticating influence of billiards were understood, every wife would be most anxious to provide her husband with a table; for the mind needs amusement after the business of the day, and persons who have been sitting for eight or ten hours at the desk or in the library need exercise; the game of billiards combines these two essentials in their most pleasing form, and what wife would not rather see her husband enjoy himself at home than find him obliged to go abroad for relaxation?

likewise afford amusement and a certain amount of mathematical instruction to as many as could conveniently sit round and watch the progress of the game.

In France and Germany, and in this country also to a growing extent, the ladies have for many years participated in this noble game. The greatest, the wisest, and one of the purest of modern women, the celebrated Madame de Stael, was an enthusiastic advocate of billiards, and one of the most brilliant players of her age; even when exiled to Switzerland by order of Napoleon she overstayed the time limited for her departure from Paris, in order that she might personally superintend the removal of her billiard table. The late Duchess de Berri was also very fond of the game, and highly skilled in its execution; her example gave the tone to Parisian fashion, and to-day the billiard room is regarded as an indispensable adjunct to every chateau of any pretension on continental Europe.

In country houses, removed from the theatres and operas, the balls and soirees of metropolitan society, the "noble game" would supply the place of these excitements with something healthier and purer. We should all sleep more soundly, if we made it a rule to play billiards for an hour or two each evening, before going to bed. Our wives and children would be more healthy and happy, more affectionate and fond of home; for there is nothing which endears the family circle so intimately, as the recollection of amusements shared in common—of games in which we all took part.

At the game of billiards, more than at any other game or exercise within our knowledge, the observer of national characteristics will have an opportunity of studying those peculiarities of the individual whose aggregate is the character of his country. Thus we find that the Frenchman, whose artistic eye and mathematical genius make him the best military strategist of all the European nations, is also by far the most brilliant billiard player to be found in the world: his conceptions are daring, and his execution has all the finish and rapidity of one with whom it would be presumption for a less gifted player to contend: his opening is a succession of *coups d'etat*, and if we did not know that his pace was a "killing one," we should feel tempted to throw down the cue in despair, and ask the marker how much we had to pay for the table? But, alas! his success is his destruction; his most brilliant *coup de main* only accelerates his ruin: he is intoxicated by the triumph his own genius has in part achieved, and the vivacity of his play evaporates before the game is half concluded. For single strokes of almost miraculous adroitness he puts forth all the skill he is master of; but for the patient foresight and self-restraint which are necessary to a prudent management of the balls, he is utterly unfit. He would not forego the chance of a brilliant shot, even though he knew that it must leave the balls in a position from which his adversary may make an easy run to game: he cares not to win, so long as he can make it clear that he *could* win, if he chose always to play as carefully as he does upon occasion: so long as he is confessed to be

the "most brilliant billiard player," he cares not who is called "the best."

The Englishman, on the other hand, in this, as in almost everything else, is the direct reverse of his late imperial and imperious ally: he looks to the result, and does not care the snap of one of his portly fingers by what means the victory has been gained, so long as it is his, *de facto*: he knows that his conceptions, though profound, are far from lively; and he flatters his tardy execution by the maxim that "all great bodies move slowly." He is the very essence of patience and laborious foresight in his play; if care could win a game the Englishman would never lose. But he is so opposed to "rashness" of every kind—so averse to those progressive ideas which he in general sums up under the head of "impracticable," that he would lose a stroke which, though difficult, is probable, rather than forfeit that reputation for prudence upon which he especially prides himself. He "forgets to remember," as the saying is, that it was care killed the cat; and though his game is a very strong one, and perhaps of the two more safe than the Frenchman's, still it is marred by excess of caution, and numberless counts are lost from the timidity which will not stretch forth its hand to grasp them.

Halfway between these two, and combining the peculiarities of each, stands the American billiard player. With much of the Frenchman's vivacity, and all his hardihood, his conceptions are bold enough to seize all the possible advantages of a stroke, and his manipulation, though less delicate than the Frenchman's, is su-

perior to the Englishman's in quickness, ease and force. On the other hand, he is proverbially a man that calculates the cost of his whistle before sitting down to enjoy it: the problem of each stroke passes rapidly through his head before he strikes; and though he does not "manage the balls" (as a general rule) so *exactly* as the plodding Englishman, he foresees the position in which they will be placed clearly enough for all practical purposes, and his judicious audacity gives him counts, which the more timid player would lose for the simple want of trying.

It has always been an easy task to speak well of the Athenians in Athens; but we cannot be accused of flattering our readers, when we simply state a fact, which every observer of experience must have long since noted: to wit, that the Frenchman is the most brilliant, the Englishman the most careful, the American the most successful—and therefore, if that be any argument, as it is commonly admitted to be the most conclusive—the very best of billiard players.

The German game is by far too ponderous and speculative a theme for us, to attempt its discussion: its theories are no doubt correct—at least, in the absence of other proof, we must believe them so; but as all human attainments fall short of the ideal, their execution does not bear any due proportion to the amount of thought that has been expended on the solution of each problem. They are continually attempting fantastic strokes, which have little else except their difficulty to recommend them; and their play has all the laboriousness of the Englishman's, without being directed to

a purpose of the same practical use. Their minds are too metaphysical for a game in which manual dexterity, and mathematical precision of the eye, are the two grand essentials of success; and, however excellent their speculations on the abstract *science* of the game may be, we find that they are frequently aroused therefrom by an announcement that the *art* of their opponent has turned their dream of victory into a dream that is never to be realized.

Italian players play very much as the French; and we have never seen enough of the Russian mode of play to pronounce an opinion.

Not only national character, but individual as well, may be profitably studied in a billiard saloon; for under the genial and exciting influence of the game, he must be a very cold-blooded or designing man indeed, who will not suffer his real nature, at some moment of interest, to break through and exhibit itself.

Having made these prefatory remarks in a spirit of conciliation, and with a hope that they may help to dissipate some of the well-meaning but mistaken prejudice, which persists in confounding this truly scientific game with the blind and reckless chances upon which the gambler stakes and loses all he has on earth—health, character and fortune—we shall now proceed, as well as we are able, to a more particular consideration of the game of billiards as an art.

CHAPTER II.

ON THE MACHINERY OF BILLIARDS—THE TABLE AND ITS APPURTENANCES—IMPROVEMENTS IN THE CUE AND CUSHIONS—THE OPINION OF A GOOD AUTHORITY.

WE will suppose that our reader is a perfect novice in the noble game—one who does not know a billiard from a faro table, but imagines that there is a very dangerous similitude between the morals and appearance of the two.

Let us now strive to dissipate his ignorance.

THE BILLIARD TABLES commonly in use are twelve feet long by six across. The length may vary, but the proportions must remain the same; that is to say, the table must be twice as long as it is broad.

The frame of the ordinary table is made of rosewood, oak, mahogany, or other woods, at the option of the purchaser. The bed or surface of the table is of timber, marble, or slate, and should stand at an elevation of some two and thirty inches from the floor. This bed is covered with a fine green cloth, and around its sides run cushions made of some elastic substances, and covered with a similar protection. At the four corners of the table there are holes made large enough to receive the ivory balls, and beneath these holes are pockets of silken netting, into which said balls may safely drop. At each side, exactly in the middle of the

length, there are similar pockets, making six in all; and along the top of the sides you will observe little pieces of ivory or mother-of-pearl imbedded at regular intervals, as if to mark some particular distance on the board. These are called the "sights," and their use will be explained hereafter; it is enough for the present to observe that there are six of them along each side, and three at top and bottom.

Formerly each table had a "passe" or iron arch affixed to it, through which the balls, at particular periods of the game, were obliged to be played; but this obstructive and useless appendage has long since disappeared, and its place is supplied by what is called the "string,"—an imaginary line drawn across the top of the board, midway between the corner and side pockets.

THE CUE is a long, straight, tapering pole of well-seasoned white ash, tipped with leather, varying in length from five feet to five feet five inches, and in weight from seven to twenty ounces. It is very desirable to establish uniformity in everything connected with the game, as otherwise a change of instruments may disarrange our previous calculations, and render our experience futile; for this purpose we lay it down as a general rule, that the cue should be two and a half times the weight of the ball with which we play.

The improved cue, though the scientific perfection of the game depends so much upon its mastery, is comparatively a modern innovation, and was assailed in its infancy with the same arrogant and blinded venom which we find in our own day displayed

towards other improvements of fully equal importance. Be it known, then, that up to the commencement of the present century, the mace was the instrument with which the game of billiards was almost universally played. This mace consists of a square-fronted box-wood head, attached to a fine ash pole, of some four or five feet in length; it is still much used by ladies and children, in their first attempts to learn the rudiments of the game. But to return to the cue as it was known to our grandfathers at the commencement of the present century; it was an improvement on the mace, we admit, being little more than the mace without the head! It was a simple wooden pole, not tipped with anything to break the harshness of the stroke, and its improvement over its predecessor consisted chiefly in the fact, that in playing with it the idea of making a natural "bridge" with the left hand on the table was first eliminated.

When this step in advance had been made, it was confidently asserted that the force of progress could no further go; the game of billiards had already reached its grand climacteric—its zenith, and any further attempt at an advancement would be a step in the downward course.

And yet, at that very time, a new discoverer was preparing to effect a thorough revolution in the game, and one, which has undoubtedly increased the scientific capacities of play to an immense extent. Monsieur Minguad, to whom we are indebted for the present wonder working capabilities of the cue, was a professional billiard player,

who had frequent reason to lament the "miscues" or false strokes which were unavoidable, where hard wood came in contact with slippery ivory. To soften down the harshness of his stroke and to avoid these slips, he conceived the idea of covering the end of his cue with leather; and we can only compare the discoveries which followed, to those made by Aladdin, when, in attempting to clean the lamp of the genii, he rubbed it, and found that by rubbing he had created a spell which placed an army of magicians under his control. No theoretical deduction suggested to Mingaud the wonderful phenomena that would result from the apparently unimportant change; but we must give him credit for the untiring and indefatigable boldness with which he pursued his chance-made discoveries to their legitimate conclusion.

How astonished were the billiard players and the billiard table manufacturers of Mingaud's day, by the results of his invention! These latter gentlemen then thought, as still they seem to think, that unto them belonged a patent monopoly for all the improvements that were, or could, or might at any time hereafter be made in the noble game; and when the cue with a leather tip was first brought before their august consideration, they did not fail to lavish on the discoverer such epithets as "innovator," "dreamer," and others of an equally complimentary character.

" But facts are chiefs that winna ding,
And downa be disputed,"

as Robert Burns said long ago; and when the inde-

pendent amateurs of Paris saw the practical operation of Mingaud's discovery—when they saw the ordinary laws of motion apparently reversed in obedience to the whim of the person wielding the (then modern) cue—when they saw him, with a perfect mastery of his own ball, sometimes force it to describe a curve around a hat placed in the middle of the board—sometimes compel it to make angles diametrically opposed to the ordinary laws as hitherto expounded and believed—when they saw the same ball apparently possessing scarce enough force to arrive at a cushion, suddenly gather strength at the moment of contact, and fly off with increasing velocity. When they saw these things, we say, it seemed to them like magic, and it was lucky for Mingaud that the statutes against sorcery had been repealed before his day.

These miracles, as they then seemed, have since become familiar and explainable. Their exact principles and practice will be illustrated in our subsequent engravings; and, with such simple instructions as we mean to give, the merest neophyte of the present day will be enabled, after a few experiments, to perform such strokes as would have won him a wide renown in the days of his respected grandfather.

THE BALLS should be of a uniform size, and from two and a quarter to two and a half inches in diameter. Those of two and three-eighths in diameter, if made of the best East India ivory, close-grained and properly seasoned, will average a weight of seven ounces each, and are those best suited to the game, and now most commonly in use. Great care should

be used in the selection of the ivory out of which these balls are turned; for if not perfectly dry, or, in other words, seasoned, when put upon the lathe, the moisture will be drawn forth by the heated atmosphere of the billiard room, and either an imperceptible bias or a perceptible crack will be the result. In either case the ball will be rendered useless for the purposes of scientific play. The ivory brought from the island of Ceylon is the best that can be used for billiard balls, the tusks being far more solid than those from Africa, less friable than those from Continental Asia, and more elastic in proportion to their density than any other. They are dreadfully dear, however; and if any inventive genius would discover a substitute for ivory, possessing those qualities which make it valuable to the billiard player, he would make a handsome fortune for himself, and earn our sincerest gratitude.

THE ARTIFICIAL BRIDGE is an instrument that should never be used, when it is any way possible, without serious inconvenience, to form a natural bridge by stretching forward across the table. It is made of an ash pole inserted in a cross-head of a bridge form, with three or more notches in its upper side. In any of these notches we may rest the cue, when the balls are in such a position as not otherwise to be readily reached.

THE CHALK should be carefully selected from the best French brands; for if impure, or retaining any of the grit or grease which we sometimes find in common grocer's chalk, it is worse than useless, and will rather increase than diminish the chances of a miscue.

THE COUNTERS, if for a public room, should be hung

upon a wire about four and a half feet above the table, and running lengthwise with it. When placed transversely, as is sometimes done, they are more apt to distract the player's eye. For a private room, where no marker is kept, a light mahogany frame with the counters hung on wires across it, will be found the most convenient: it can be placed upon the chimney-piece, or on a stand at either end of the table.

A BILLIARD ROOM for a single table should be twenty-four feet long by eighteen wide—but twenty-two by sixteen would do upon a pinch. Why will not our architects, in their plans for modern mansions, make suitable provision for that amusement, without which no gentleman's establishment (more especially if a country one) can now be considered perfect? Even if the builder of a house have no taste for the game himself, he should look beforehand, and consider that such an accommodation might form an important item in the price which a succeeding tenant would be willing to pay for it. For two tables, the room ought to be twenty-four by thirty; for three, twenty-four by forty-two, and so on, in proportion to the number of tables. The light, if possible, should descend from above, through ample skylights, so as to bring the table within a general focus, and thus prevent any shadow being thrown from the balls or cushions. The gas-light should be raised about three feet six inches from the bed of the table, and supplied with horizontal burners, as by such an arrangement no shadow is cast from the pipe. The floor, if carpeted at all, should be covered with some thick soft material, to prevent injury

to the balls in case of their "jumping" the cushions. If not carpeted, as by some preferred, particular care should be taken to have the heads of the nails in the floor driven down, for a like reason.

THE CUSHIONS of the table are the last, but by no means the least, of the appurtenances of billiards, to which we devote our attention. Indeed, we purposely omitted them from their natural connection, in order to give a clearer view of their importance, when taken in connection with the whole.

The game of billiards, as we know, is a series of mathematical combinations and effects, depending in part upon the laws of motion, and in part upon a just appreciation of the angles of incidence and reflexion which are made by the balls, as they bound from side to side, across, and up and down the board. Every motion of the balls, supposing the machinery of the table to be correct, can be calculated beforehand, with the precision of an astronomical thesis. The weight of the ball is so much—the force applied to it is so much—the angle at which it strikes is one of so many degrees—and the result must infallibly be so and so. If, therefore, we could suppose the whole machinery of the billiard table brought up to the standard of absolute perfection,* and that an automaton player, equally

* We find, in a work written by Edward Russell Mardon, a celebrated English player, to whom we shall have occasion to refer hereafter, a true, and most amusing account of the origin of India-rubber cushions. It is so good, that we make no apology for quoting it in extenso :

" One of the inventors of the India-rubber cushions, being a bil-

perfect, could be made, the game would then lose "the delightful flavor of uncertainty" which, even with the best of players, gives to it its present excitement and zest, and would become a congeries of propositions, as dry and uninteresting as the tables of arithmetic. To the imperfections of our physical and mental nature—to the variability of our nervous condition, and the misjudgments of the eye, we owe that admixture of uncertainty which forms the highest zest of all cultivated and refined amusements.

Until very recently indeed, the cushions used, were notoriously and grossly defective. Those made of cloth, from their undue passiveness and want of elas-

hard-table manufacturer, as well as an excellent player, and quite capable of judging correctly, respecting the precision of an angle, placed his maiden cushions on a table of his own, and proceeded, ere they were exhibited, to try their effect. The balls had not been many times struck, before the incorrectness of the angle became apparent, and their immediate removal was contemplated. The table, however, having been engaged by gentlemen at a given hour, and the intervening time not allowing of their being replaced by others, the cushions were permitted to remain. The gentlemen arrived—they commenced playing. The speed, the extraordinary speed, filled them with amazement; and, as the games went on, their delight kept pace with their surprise. The inventor smiled, and, if I am rightly informed, thus expressed himself: 'If the public is pleased, the cushions may as well remain.' But, had the table, upon which the experimental cushions were placed, *been first played upon by scientific players*, the absurdity would have been at once condemned; their removal would instantly have taken place; and cushions, *too fast to be correct*, would never have disgraced a game, whose beauties and scientific properties are governed by, and wholly dependent upon, the truth of an angle."

ticity, had the effect of deadening the original force, to an extent which made the angle of reflexion incalculably more obtuse than that of incidence: while, on the other hand, those made of India-rubber, from their excessive elasticity and resistance, permitted the impinging ball to bury itself too deeply in their surface—thus the ball, as it were, extemporizing a cushion *in front of it*, and rebounding at an angle more acute than the angle at which it struck. To India-rubber, as at first used—that is to say, in its raw condition—there were serious atmospherical objections; in frosty weather it became as hard as an adamantine democrat, and required to be thawed out semi-hourly, by the application of tin tubes filled with boiling water; while in sultry summer days, the rubber melted, and assumed the consistency of baker's dough—for which the remedy, if any, would seem to be a semi-hourly icing. In the intermediate intervals between these various operations, it must be evident that the cushion, so boiled or iced, would present a different consistency each moment, and, therefore, must necessarily reflect the impinging balls at various angles; and thus, no amount of experience could enable a player to counteract by calculation the radical defect; for his ball, striking at an angle of 40° , when the cushion was very warm, might slide off at the angle 20° ; while, striking at the same angle, when the cushion was a trifle colder, it would be tossed back at the angle of 50° —and so on, through all the varieties of heat and cold.*

* In a work on billiards, published as long since as 1844, by Edward Russell Mardon, a famous English player, we find some

Objections of a like nature, though arising from different causes, attached to all the other cushions which had been devised at various times and by various persons, with a view to remedy this admitted evil; until at last, the writer, a billiard-player, who had suffered much from the irregularities which were beyond his control, and which often rendered his most careful play of no avail—determined to try whether his practical experience of the evil might not enable him to hit upon a remedy; and was at last fortunate enough to discover a combination of substances which seemed to supply the long sought for desideratum.

That his discovery was a valuable one was proved by the eagerness with which the established manufacturers of billiard tables laid hold of, and appropriated

observations, which we quote for the support of our remarks. He is speaking of the necessity of correct cushions and graduated strengths:

“In order that success may be insured, it is necessary that the speed of the bed of the table and the return from the cushion should be equal; and that they should, of course, continue so from day to day; but I am informed by a maker of experience, intelligence, and close observation, that cushions, stuffed with India-rubber, are so susceptible of change of temperature, that the effect of it has even been experienced during the continuance of a match. Thus the best of strengths at eleven in the morning, might prove the worst of strengths at five in the afternoon!” * * * “How wretched, to a player possessing an eye accustomed to geometrical demonstration, must appear the running of the balls, when returning from cushions so palpably untrue; and how mortifying to witness the unfavorable result of a well-played stroke, that ought, with correctness of angle, to have insured the winning of the game.”

its improvements. That the cushions formerly in use were defective and irregular, had never hitherto been denied. But when the inventor announced his intention of protecting his discovery by a patent, and thus reaping some portion of the reward of experiments which, though now successful, had not been carried on without much anxiety and expense—and when the protecting patent was at length, despite their combined opposition, granted to him,—the whole merits of the case were changed, and the cushions formerly condemned as irregular were extolled as the acme of perfection, while his combination—which they had pirated and used, so long as they could do so without rendering themselves liable to the penalties of the law—became the object of their united defamation. In fact, it seemed as if the guild of “regular manufacturers,” as they called themselves, considered that to them belonged a “heaven-born right” to be the sole introducers of any improvement into their particular branch of mechanics; and though they failed themselves to make the improvements which were needed, they were determined that no “outsider” should shame their inefficiency by proclaiming in his own name a discovery from which a new era in the game of billiards should be dated. If the inventor would have sold his patent-right to them, they were prepared to pay liberally (so they said) for its use; but as he had no confidence in their professions, and no guarantee that they would not, from motives of a mistaken economy, supply an inferior combination to that specified in his patent, (thereby injuring his discovery in public estimation,)

the discoverer declined to make any arrangement of the sort, and from that moment it became the object of his opponents to destroy the favorable impression which the combination cushions had already made, wherever used.

But as this may be regarded as an affair of private competition, and as the billiard-playing public have given an emphatic verdict in favor of the invention, the subject may be dismissed for the present.

The author does so the more gladly, from the personal nature of the discussion. He would have avoided it altogether, had not the frequent publications made on the other side, of a defamatory nature, rendered this simple statement due to justice, and to the merits of a case in which all who would promote the scientific development of Billiards, must be deeply interested.

Of the further improvements made in the Model Tables which bear his name, the author is restrained from speaking by motives which can be easily appreciated. He will only say that every subsequent improvement in the models (improvements since ratified and secured to him by the grant of additional patents), was dictated by practical inconveniences which he experienced in the old; and referring the reader to an article from the *Scientific American*, dated Dec. 23d, 1855, and descriptions of the improvements which he has subsequently patented, which will be found in the Appendix, he will now take his leave of the "machinery of the game of billiards," and apply himself to its practical and scientific illustration.

CHAPTER III.

THE GENERAL PRINCIPLES OF THE GAME DEFINED, WITH A VIEW TO THEIR PRACTICAL APPLICATION IN THE DIAGRAMS WHICH ARE TO FOLLOW.

THE art of playing billiards must be taught by practical experience; no amount of intellectual study can impart to a novice the manual dexterity and adroitness which are essential to the accomplishment even of the very simplest strokes. But a student may save himself months—we had almost written years—of laborious investigation and experiment, by learning thoroughly, beforehand, the principles of the *science* which he is afterwards to practice and master as an *art*. It will be no small gain for him if these pages instruct him how to start right, from the commencement—if he is made to understand what he will be required to do, before he attempts to do it; and if he is given such an intelligent view of the game as will cause him to appreciate, from the outset, the value of the different experiences which each successive stroke will give.

Wherever it is possible for the student to place himself under a competent professional instructor, during the first month of his noviciate, he should by no means neglect to avail himself of the immense advantages which may be thus acquired. He will be given the full benefit of his teacher's experience, and may

thus make more scientific progress in a month than another player, not possessed of such assistance, could make in a year. The original discovery of any one of Euclid's propositions might be the task of a lifetime, and could only be achieved by a person of mathematical genius; but with the aid of an instructor, and the benefit of his experience, a boy of very ordinary powers may master the whole six books in as many months.

Not only the novice, but the average amateur also, would do well to avail himself of the assistance of a tutor. As a month's teaching would raise the novice to the rank of an average player, so the same instruction would elevate the average amateur to the rank of a professional master.

The present chapter will be devoted more particularly to the instruction of beginners; but we are confident, at the same time, that its careful perusal may be of service to all. For how many are there who play billiards mechanically, and execute the most beautiful propositions without once pausing to examine and admire the essential scientific beauty which is involved in their mechanical play! Let them once be made aware of the true principles of the art which they profess, and the pursuit of it will forever after yield them a double pleasure. And first let us consider the

CONDITIONS OF A GOOD ATTITUDE.

The acquisition of a good attitude is a point of the first importance to the young student of billiards;

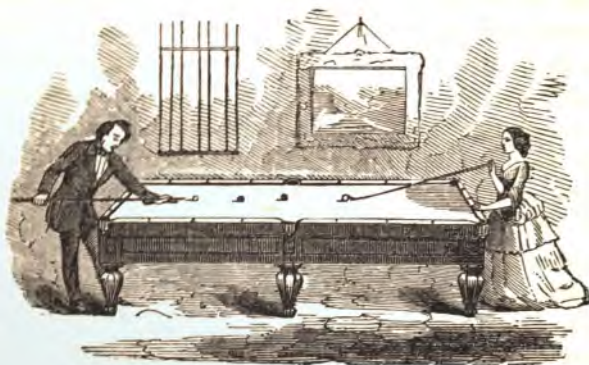

and yet, from its purely physical nature, is a subject which almost defies the control of any written rules. There are peculiarities of height and figure which render the rules that would be excellent in one case, totally inapplicable in the other; thus it is impossible to define by inches the distance at which a player should stand from the table, when about to strike; for not only will the different statures of men cause a difference of position—but, even with the same player, different positions of the ball will call for corresponding changes of attitude.

Under these circumstances, the best we can do is to give a general direction, which each student must apply for himself to his own particular case. Let him

stand with his left foot slightly advanced, his left arm extended and resting on the table to form a bridge, his body, not facing the table squarely, but forming an acute angle with the side at which he stands;

let him relax all the muscles of his limbs into their usual and most natural posture—for rigidity of body is at all times awkward and ungraceful, and seriously interferes with play. The cue, though allowed to rest loosely in the hand at the time of drawing back, should be held firmly at the moment of contact with the ball; and in all strokes, except the “jump” and “perpendicular force,” the direction of the cue should be maintained as much as possible in the horizontal. The striking motion should be confined to the arm, and chiefly to the lower division of it; the “shoulder-hitters,” in billiards, or those persons who throw their bodies forward after the cue, would do well to renounce the “noble game,” and turn their evident capacities to what its professors call “the noble art of self-defence.” Their shoulder-hitting might make them first rate pugilists, but totally unfits them for a game in which delicacy of touch and firmness of body, eye and purpose, are the grand essentials of success. The body should remain immovable as a rock, while the right arm swings to and fro at a sufficient distance to avoid contact with the side, when advancing. All spasmodic motion and muscular contortions should be avoided; mere bodily strength in the player will not give strength to his stroke; the quantity of motion imparted to the ball will correspond precisely with the weight of the cue multiplied by the velocity with which it is advancing at the instant of contact; and therefore the only force required from the player, even for the strongest stroke, is force enough to cause his cue to move forward at a rate of speed which, multi-

plied by its gravity, will give the required result. As aforesaid, this motion should emanate especially from the fore-arm. It is impossible to describe exactly what we wish to convey; but if our readers, when striking, will imagine that they are throwing a lasso, and give the same quick, steady force of wrist to the cue that is required in flinging the coil, they will understand exactly what we mean.

It is owing to the knowledge of this secret, that men, physically weak, are frequently more than a match in billiard-strength for players who have the proportions of Hercules, and the "dead pull" of Sampson when he brought down the pillars of the temple on the heads of the assembled heathen.

The attitude of ladies, when playing, is much simpler, from the fact that, as they almost universally use the mace, they are not called upon to lean forward to form a bridge with the left hand. The end of the mace which they hold, should be rested between the thumb and second finger, in such a position that the eye may run along it from its top to the point of contact; the head of the mace should be in contact with the ball at the moment of playing; and when the purpose of the stroke is determined, the forefinger should be brought firmly down upon the end. It is quickness, not actual physical force, that imparts strength to the ball, whether shoved with the mace or struck by the cue. As for the attitude in which a lady should stand while playing billiards, no instruction is needed; perfect ease is perfect grace, and perfect ease of position is the grand DESIDERATUM for the

billiard-player. As the ladies are always graceful, or at least study to be so, they will naturally observe that ease of attitude which it is only necessary to enforce upon the ruder and more awkward sex.

To the male novice we would say: avoid all stiffness and parade—avoid all affected dignity. Let your dress and attitude be such as to afford your body a perfect mastery of its own movements. A practiced eye can discriminate at the first glance on entering a billiard-room, which is the really skilful player, and which the pretentious bungler, by merely noting the contrast—which the good player's easy grace presents to the rigid formalism of the other. Paganini, in his younger days, when he taught the violin, used to give his pupils six months time in which to practice how to hold the instrument and bow. When they understood that thoroughly, he could teach them, he said, the remainder of the art in a few weeks.

Now, without requiring so long an apprenticeship—without, in fact, requiring any apprenticeship at all—if the student will only allow himself to stand in his natural position, we insist upon it that the attitude and mode of holding the cue are just as important to the billiard-player, as Paganini pronounced the things aforesaid to be to the aspiring musician.

The left foot should be pushed slightly forward, pointing straight ahead, while the right is withdrawn, and turned outwards, at whatever angle is habitual and most convenient to the player. The body should be fairly balanced, for without this equilibrium, we can neither have grace nor ease. The left arm, when

necessary, should be advanced and rested on the table—the left hand being extended, as in the cut, to form a “bridge.”

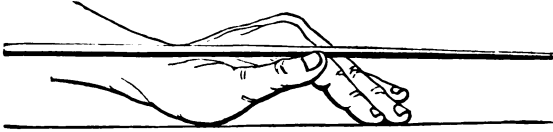

The bridge is formed by placing the left hand about six inches from the ball to be played on, and then drawing it up until it rests on the ends of the fingers and wrist, or ball of the hand, at an angle which is here represented. The thumb is then brought up firmly to the forefinger, so as to form a groove in which the cue may slide. The wrist, and points of the fingers, should be moderately pressed upon the table, to give strength and solidity, and then you have a “bridge” over which you may travel pleasantly and safely, into the golden realm of billiards.

The right arm, holding the cue, should be a little withdrawn, bent so as to form an obtuse angle at the elbow, and kept sufficiently far from the body to render its advance and retreat unimpeded; for if the player fall into the habit of allowing the arm, while striking, to rub against the side, he may as well give up all further attempts to learn the game, until he shall have first unlearned that habit. The cue should be held firmly, but without effort, in the hand, and moderately pressed upon the bridge, so as to avoid vibration while in the act of making the stroke; especially, in all attempts at making the “force,” “following,” and

"twist" strokes, which will be described hereafter. Our readers may get a better idea of our meaning by studying the accompanying plate, and placing themselves in what we may literally call "the striking position," which the gentleman there occupies.

The attitude in which a lady stands while playing billiards, is less difficult to explain, and may almost be studied from the illustration. The mace is a simpler instrument, inasmuch as it requires no bridge to be formed, and, consequently, no exertion in leaning or stretching forward over the table; but where a lady uses the cue in playing, as we counsel them to do, the same rules will of course apply to her that we have laid down in the preceding paragraphs.

But to return to our directions for gentlemen, who really NEED more guiding: let the arm hang free, and strike with the whole of it; but keep the body firm, and do not let the right shoulder move forward in the same direction with the arm when you strike. Let the stroke be delivered in an even, easy, and regular manner. Avoid all spasmodic movements, for they spoil the aim. Do not bring the end of the cue too close to the ball. Let there be a distance of from one to two inches between them, depending on the character of the shot you wish to make.

Select a cue in harmony with your physical powers, and accustom yourself as much as possible to play with cues of a similar weight. If you play regularly in any billiard-saloon, they will be happy to keep a cue for your especial use. From fifteen to sixteen ounces are fair weights, according to the size of

the balls now used in play. A cue, if too heavy, will paralyze the nerves of the arm and render them unable to estimate correctly the amount of force employed: if too light, on the other hand, it will call for an amount of force so great as to be incompatible with a steady and deliberate aim. Finally, let the cue be straight, for any crookedness in this instrument distracts the eye, and may seriously interfere with the manual correctness. The cues with inlaid and ornamental stocks are more to be admired than desired. As memorials of either friendship or victory they are most excellent; but for playing—give us the simple ash pole, tipped with leather.

In a little poem in the Appendix, entitled "Attitude is Everything," the writer—a celebrated amateur of this city, and one for whose many favors we here desire to make our sincere acknowledgments—has hit off admirably some of the leading peculiarities of style which disfigure even the most careful play. His poem fitly illustrates the adage that nothing forbids us to tell sober truths with a laughing lip; and as we could add nothing to the force of his descriptive sarcasm, it is better to let our readers have his observations—with all which we entirely agree—put forward in his own pleasant style. The poem, with copious illustrations, will be found in the Appendix.

The leather is an important feature of the cue—in fact, an all-important one to any player who deals much in the strokes which are technically described as "forcing," "twisting," and "following." With an inferior leather, his play will be paralyzed by mis-cues.

In selecting the cue-leather, choose from the best French brands, such as possess the finest fibre, and are at the same time solid, pliable, and elastic; and see to it that you have a good, solid under-leather, say a sixteenth of an inch in thickness, as that will save the point of the cue from breaking away, and will last longer than a thin one. Before being fitted on to the cue, they should be thoroughly well beaten out on a lapstone, so as to prevent them from spreading in the course of play; but that side of them which is next the cue should be roughened with a file or sandpaper, as also the cue itself, in order that the adhesive wax may be able to take good hold. Each must decide for himself the exact degree of convexity in the leather which will best suit his play. When the point of the leather becomes glazed from excessive play, a little sandpaper should be used to roughen it, so that the chalk may stick.

To the best of our ability, we have now placed our reader in a good attitude, and given him such an instrument as he requires for the commencement of his studies. Let us now caution him against two opposite faults, into which beginners are too apt to fall. Some strike too precipitately, delivering the stroke before their cue has got properly rested on the bridge. Others, at the imminent risk of lockjaw, keep sawing their cue backwards and forwards on the bridge aforesaid, at least a score of times, before they can screw their courage up to the striking point. We sometimes almost fear to see their thumbs drop off, worn through and through by this protracted friction. In a brass-

finder's store or marble-mantle manufactory, these "POLISHERS" would be invaluable. Aim calmly, strike firmly but gently, and content yourself at first with centre-strokes: when you have thoroughly mastered these, you will find the "follow" and "force," the "jump" and "twist" strokes easy; but if you attempt to learn them all together, you will get them so jumbled and confused in your mind as to be indistinguishable forever after. Bear this in mind also, that in all ordinary strokes the cue should be held as much as possible in a horizontal position. The perpendicular, force and jump strokes, are, of course, excepted.

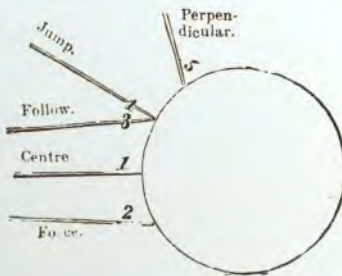

When you have mastered the centre-stroke, you will then begin to study the different effects which different modes of striking will produce. These you will find illustrated in the accompanying plate, and we endeavor to explain, not only what the effects are, but the principles from which the different effects take their rise, and which are necessary to produce them.

The centre-stroke, marked 1, is called the CENTRE-

STROKE, and supposing the ball so struck, to meet the object ball "dead full," or strike it in the centre, the motion originally imparted to the cue-ball would be transmitted to the other, and the cue-ball would come to a full pause, while the object-ball advanced in the same right line, and with a force equal to that originally imparted to the cue-ball—minus the friction of the intervening space and the amount necessary to overcome the specific gravity of both. But the friction of the table, meanwhile, has imparted a rotatory motion to the cue-ball independent of the original impelling force; so that when the impelling force is all transmitted to the object-ball, the individual rotatory motion will still remain, and the cue-ball may rotate a few lengths farther until this has been exhausted.

The stroke (3) is called the **FOLLOWING STROKE**; and supposing the cue-ball to be impelled against the object-ball by such a force, it will continue to follow or advance in the same right line with the object ball, although with a decreased momentum. This arises from the fact, that by striking the cue-ball above the centre of gravity, we impart to it a forward rotatory motion wholly independent of the impelling force. When, therefore, the striking force is transmitted to the object-ball, this motion still remains unimpaired, and causes it to advance irrespective of the loss of force of which it was originally independent.

The stroke (4) is called the **JUMP**, and is of less importance than the others. It causes the ball to spring up more or less from the table, according to the degree of strength with which it has been struck. The jump-

ing motion is thus imparted on the same principle that a ball will rebound, if flung or dropped against any elastic surface, or if possessed of any elasticity itself.

The stroke (5) we may call the **PERPENDICULAR FORCE**, and is one of very difficult accomplishment, and therefore seldom played, except in the French carom game, where no pushing strokes are allowed. Still, there may be cases—the player's ball, for instance, being placed between two other balls, and in such close proximity to both that a carom can be effected by no other means*—where it will be useful to understand it. Its principle is identical with—or rather the exact converse of—that on which the **FORCE** is made, and as No. 2 is the most common, we may allow its explanation to stand for both.

Stroke 2 is called the **FORCE**, and is one of the most beautiful and useful in the game. By striking the ball below the centre, and with a quick, sharp force, two completely distinct and even antagonistic movements are imparted to the ball. The one urging it to advance in the direction of the impelling force—the other inclining it to rotate backwards on its individual axis. Let us imagine a wheel, for instance, with the rim taken off, and suspended on its axis in the air, and we shall then understand the principle in a

* The reader will see, in one of the succeeding diagrams, a very curious instance of this necessity, which actually occurred to the author when he was playing a match in San Francisco against M. Damon, who was then esteemed the ablest French billiard-player in California. Had he then failed to make the perpendicular force, **the game would in all probability have gone against him.**

moment. The same principle will also apply to side and quarter strokes, and it is therefore the more important to have it clearly understood from the commencement.

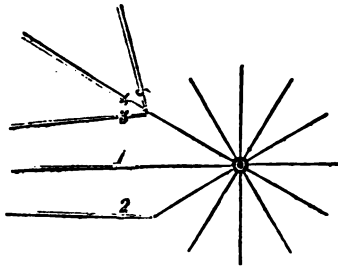

If we strike the cart-wheel fair in the centre (No. 1), its only tendency, supposing it to be suspended in the air, will be to advance forward in the direction of the impelling force. If we strike it forward and above the centre (No. 3), two tendencies will be imparted; the one to advance in the direction of the force—the other to rotate *forward* on its own axis. In the FOLLOWING STROKE, which is the same, when the force is imparted to the other ball, the rotatory motion still remains to carry the cue ball forward. If we strike it downward and forward (stroke 4), there will be a tendency to jump up from the concussion, and also to advance in a line with the impelling force. This can be understood better by striking an India-rubber ball downward and upon the side with a hammer, when the ball is at rest on any solid bed; it will instantly spring up, and bound forward from the point at which it has been struck. If we strike one of the spokes of the

cart wheel (No. 5), almost perpendicularly downward and from above the centre of gravity, the tendency to rotate backward would be the only one communicated to the wheel. But with the ball—which is a wheel with an infinitude of spokes—this tendency may be paralyzed or held suspended for an indefinite period by the forward force, but will quickly re-assert itself, and cause a retrograde effect. If we hit the wheel below its centre of gravity (No. 2), the double tendency to move forward in the direction of the impelling force and rotate *backward*, will be at once perceived; as soon, therefore, as the forward force has been either exhausted by the counteracting tendency of rotation, or imparted to another ball by striking it, the wheel or ball will tend to retrograde to the point from which it started.

Let this double tendency of motion—this active and suspended force communicated to the balls, by the act and manner of striking—be attentively studied, and it will greatly assist the billiard-player to solve the otherwise inexplicable problems which will be presented in the very outset of the game.

Quite similar, or rather, quite analogous to the effects produced by striking a ball either above or below its centre, on a line drawn through the centre, and perpendicular to the bed of the table, will be the effects caused by striking the ball either to the right or left of the centre, on a line drawn horizontally through the centre, and therefore parallel with the table's bed. When the ball is thus struck, at a distance of one-quarter or one-half from the centre, it will have the

double tendency to move forward in the direction of the impelling force, and rotate horizontally toward the side upon which it has been struck. Thus, when struck one-quarter or one-half above or below the centre on the perpendicular line, it will rotate perpendicularly either forward or backward. When struck in a similar way on the horizontal central line, it will rotate horizontally toward the side on which it is struck; but when struck at one-quarter or one half,

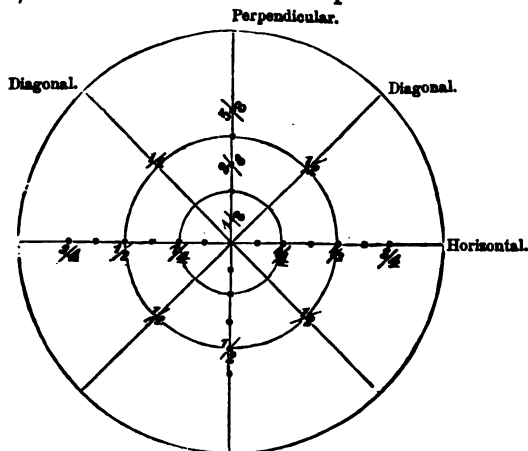

on a line intermediate between the horizontal and perpendicular, it will rotate diagonally, with a *lateral and following* tendency, if struck above the centre; and with a lateral and retrograding motion if struck below. The foregoing diagram may make our meaning clearer; and it is a point of such importance that, even at the risk of tediousness, we wish to impress it on the student's mind.

Within the circle which represents the full side of a billiard-ball turned toward us, are drawn five diameters on the following plan ; one perpendicular to the bed of the table ; one horizontal or parallel thereto ; and two diagonals, one drawn from the left to right, the other from right to left, and both equi-distant from the horizontal and perpendicular diameters.

These diameters are intersected by concentric circles drawn respectively, with a radius of one-eighth and one-fourth of the whole diameter ; but, for simplicity's sake, we have marked these $\frac{1}{4}$ and $\frac{1}{2}$, meaning thereby the half and the fourth of the half diameter. We have also, on the horizontal, marked the points at which a concentric circle, with a radius of three-fourths of the half diameter (six-eighths of the whole) would intersect ; and each reader, for himself, may mark this point upon the other lines, when told to strike $\frac{3}{4}$ above, below, or to the right or left. Both upon the perpendicular and horizontal, we have dotted off subdivisions of eighths of the whole diameter, and the same may be applied by the reader to the diagonals, we only omitting them in order to avoid an appearance of complexity. Other authors, we know, have classified the billiard-ball into much minuter sections ; but the more important subdivisions are here given, and, with the aid of the wrist in striking, these will be found to answer for all practical purposes. There are finer touches to be sure ; but for the present they would only confuse and perplex the student, and lead him into attempting things which are beyond his skill. The attempt, for instance, to strike the ball outside of the points marked $\frac{1}{4}$ on the

various diameters, generally leads the novice into a number of miscues; whereas, by striking within the points so marked, with a slightly-increased force and quickness, the effects desired can be produced, without incurring any liability of the kind.

To abbreviate as much as possible, we shall have recourse to initials only to illustrate our diagrams. A, standing for above the centre; B, for below it; R, to the right of it; L, to the left; and D, for diagonal. The points marked $\frac{1}{4}$, $\frac{1}{2}$, $\frac{3}{4}$, &c., &c., are those at which we suppose the ball to be struck. As the student advances, he will, of course, *ex necessitate*, devise new lines and measures for himself. As his mastery of the cue becomes more perfect, it will reveal to him the points at which his peculiar play requires that the ball should be touched, to produce a desired effect; but this explanatory diagram was indispensable to a right understanding of our subsequent instructions—though we know well that it neither is, nor could any diagram possibly be, sufficiently explicit for *all* the exigencies of play. It would require the Newtonian Fluxions to calculate the variations of the ball, when struck at different distances from the centre: but the reader can readily bear in mind what A, B, D, R, and L, will hereafter stand for.

The diagram following, (in which we suppose that we are looking *down* upon the balls) will explain the different motions imparted to the object-ball on being struck by the cue-ball, in the manners which are called, in billiard parlance, "Full," "Quarter," "Half," and "Fine."

The heavy lines mark the course in which the cue-ball advances to strike the object-ball. The dotted lines show the direction in which the object-ball will be driven by the contact. Let it be remarked as well, that in the quarter-ball, half-ball, and fine ball strokes, the part of the cue-ball which strikes the object-ball will exactly correspond to the part which is struck, provided the balls be of equal size. It is physically impossible with your own ball full, to strike the object-ball quarter. The lines drawn between the cue and object-balls, in the preceding diagram, show the exact relation which the parts coming in contact must bear each to the other.

The principle exhibited in this diagram is the key to the hazard portion of the game. In hazards, we may remark, that the point to be gained is to be able to make the object-ball move in whatever direction you want it: while in the carom game, you care not how the object-ball may move after it has been touched—so far as that particular stroke is concerned—provided you can command the curves and angles, force, speed, and retrogradation of your own ball.

We say that the position which the object-ball may assume after being struck, is unimportant in the carom game, *so far as that particular stroke is concerned*; but in the management of the balls, and the ability to leave them in a position favorable to the next play—or unfavorable to your opponent, if you think it impossible *to count* yourself—the grand strength and science of the game is found. Mere “brilliant strokes” by no means constitute a first-class scientific billiard-player; caution,

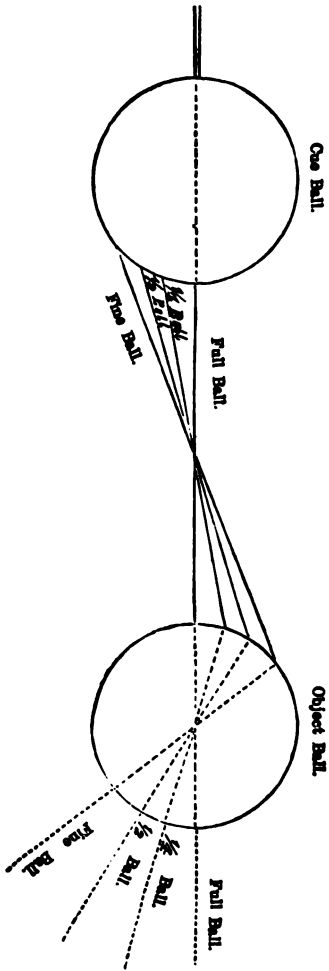

THE NEW YORK
PUBLIC LIBRARY.
ASTOR, LENOX AND
TILDEN FOUNDATIONS.

coolness, foresight, and ability to leave the balls in a position from which a good run may be secured (if the player is sure of his stroke), are of infinitely more importance. The really scientific player will never permit himself to be led astray by the mere certainty and ease of making one successful stroke, into a position from which no further benefit can be expected; he will either forego all present gain to himself, in order to diminish the chances of a greater gain to his adversary; or even attempt a more difficult play, from which it is likely some more favorable break may ensue. The thorough master of the game is he who never makes a count without leaving the balls in a position from which another count may be reasonably expected; or, should this be impossible, then in such a position as will render the making of a count by his opponent extremely difficult. From a break which appears worthless to the novice, the scientific player may make a splendid run; and he does so from attending to the proverb, which tells us all "to look before we leap."

When the player thoroughly understands the foregoing diagram, and is able to execute the necessary strokes, we may call him a master of the hazard game. It is not our intention to give any regular instructions on this portion of the game, further than those already given as to the modes of striking the cue and object-balls; for when the player has perfected himself in the execution of the theories herein laid down, he will only have to aim steadily at the exact part of the ball to be struck, to be certain of success. In doing so, he may assist himself by drawing an imaginary line from the

centre of the pocket aimed at, through the centre of the object-ball; and where that diameter terminates, is the exact point at which you must strike, to accomplish the hazard.

By attending to the principles already laid down, even the novice can become his own hazard-master, and it would be a waste of time and space to dilate any further upon a subject which is already exhausted.

The next part of our subject proper, relates to the degree of strength with which it is necessary to strike for the accomplishment of various objects. But of this we shall treat hereafter, with diagrams to illustrate our meaning.

Meantime, as we shall have to make increasing use of such technicalities as "hazard," "carom," "kiss," and so forth—terms completely unintelligible to the novice—we had better devote a short chapter to an explanation of the phrases peculiar to the noble game.

CHAPTER IV.

DEFINITION OF TECHNICAL PHRASES EMPLOYED IN THE GAME OF BILLIARDS.

HAZARD.—You make a hazard when you drive any of the balls into any of the pockets. A *winning hazard* when you hole or pocket either of the red balls or your adversary's; a *losing hazard* when your own ball is pocketed by your own act. A double hazard is when you pocket two of the balls with the same stroke.

CAROM.—This word is derived from the French *carambolage*, and you carom when you hit more than one of the balls on the table with your own. In England this is called a "cannon," being evidently a corrupt derivative.

KISS.—When the ball you play with strikes another ball more than once, they are said to kiss; or when two balls not played with come in contact.

SCRATCH.—When accident befriends you, and you win a stroke or count without either intending or deserving it, you are said to have made a scratch.

FORCE.—When your own ball retrogrades after

coming in contact with another. We have explained this in the preceding chapter.

FOLLOW.—When your own ball rolls on after another ball which it has impelled forward. (See last chapter.)

JUMP.—When you force your ball by a downward stroke (as previously explained) to ricochet or leap up from the table.

BANK.—When you make your own ball hit any of the cushions before striking the object-ball. The mace is sometimes used, even by good players, to make this stroke.

MISS.—When you fail to strike any of the balls upon the table.

MISCUE.—When the cue, either from want of chalk or being badly handled, slips off the ball without accomplishing the intended stroke.

BURST.—A term chiefly used at pin pool to signify that the player has exceeded the number which is placed as the common limit to the game, and has consequently either to retire from the game or take a privilege of another life.

PRIVILEGE.—A word used in some games of Pool to express that the player, having lost the lives, or chances, which were given to his ball on its entry into the game, now wishes to purchase still another chance as a privilege from the other players.

TAKING A HAZARD.—A term used to express that a player is so confident of making a certain hazard that he will undertake to do it, under penalty of losing, in case he does not succeed, as many lives as he would have gained if successful. The phrase is most frequently employed in two-ball pool.

KILLED, OR DEAD BALL.—When a ball in pool has lost its lives, and its chances are not renewed by privileges, it is said to be killed.

PLAYING FOR SAFETY.—When you forego a possible advantage, in order to leave the balls in such a position that your opponent can make nothing out of them.

HUG.—When any of the balls run close alongside of a particular cushion, they are said to hug it.

JAW.—When a ball is prevented from dropping into a pocket by the cushions which extend like jaws on either side.

“TIMBER-LICK,” “BOWERY SHOT” and “GERMANTOWNER” are synonymous terms, all applying when the balls played with and at, are jarred together—a pushing shot.

DOUBLET OR CROSS.—When the ball to be pocketed is first made to rebound from the opposite cushion.

FOUL STROKE OR SHOT.—Any stroke made in violation of the known rules of the game.

FULL BALL, QUARTER BALL, HALF BALL, FINE OR CUT BALL, OWN OR CUE-BALL, AND OBJECT-BALL.—For a correct definition of these, see the prece-

ding chapter, which “read, mark, learn, and inwardly digest.”

BREAK.—The position the balls are left in after a shot has been made.

STRINGING FOR THE LEAD.—A preliminary to the game, by which it is decided who shall have the choice of lead and balls. See subsequent rules for the game on this point.

DISCOUNT.—When one player is so much the superior of another that he allows all the counts made by his opponent to be deducted from his own reckoning, he is said to “discount” his adversary’s gains. Thus, if his opponent make a run of ten, ten is added to his count, and ten deducted from the discounter’s reckoning; but the discounter cannot lose what he has not got. In other words, these deductions must only be made from the count he has at the time of the loss, and cannot be recovered out of counts he may afterwards make. **IN DOUBLE** and **TREBLE DISCOUNT**, twice and thrice the amount of his opponent’s gains are deducted from the player’s score. In no other game in the world are such immense odds possible as in billiards; for the difference between players may be as infinite as the variety of geometrical and dynamic problems which the balls are capable of illustrating; and a man of what is called a mathematic head, close observation, temperate habits, steady nerves, and large experience, may give almost any odds to an inferior player, and still have a fair chance of success.

PLAYING SPOT BALL.—Is when the player is not limited to the number of times he may pocket the red ball from the Spot.

BILLIARD SHARP.—The billiard Sharp is a dangerous species of animal, now happily almost extinct in these latitudes; he is to be shunned wherever met, and the following are among the more prominent signs which nature has stamped upon him, as a caution to the unwary: He is always either over-dressed or seedy; after a "run of luck" he comes out in patterns of the "noisiest" and loudest description; his hair is always settled by a barber—in all probability his mustachios have been dyed; and you may observe in him, whether his apparel be gaudily vulgar or seedily decayed, a constant effort to ape and "put on the genteel." The very anxiety of the effort defeats the success of its execution; and the voice of the *rook* betrays his nature, even though he has clothed himself in the feathers of some plundered pigeon.

The Sharp, as a general thing, is a retired marker, who fancies it is no longer "respectable" to work for an honest living; and also fancies that he is "smart" enough, and has "learned tricks enough" at his former business, to enable him to "win as much money as he wants" from the less experienced amateurs of the game, who figure in his vocabulary as "the flats." Let not our friends, the markers, think that we desire to cast a slur on their calling: there are "black sheep" in pulpits as well as in billiard saloons; and the business cannot be held responsible for the evil-minded persons who are occa-

sionally admitted. Sometimes the Sharp is a reduced gentleman of loose morality and habits—one who is careful to assure you that “he has seen better days”—a man, perhaps, who has been plucked in his youth by Sharps now dead and gone, and who endeavors to make the knowledge so bitterly acquired, support him in idleness and affluence, after his friends have been estranged by his vices, and his fortune (if he ever had any) been exhausted upon pimps and extravagance.

These sharps are rarely seen in a respectable saloon: they rather patronize those peculiar establishments where a couple of billiard tables are made the “fence,” behind which some less reputable occupation is carried on; and here they are at home, and in their glory. They are familiar with the proprietors, and make themselves useful in a large variety of characters, in return for which they are received as “dead-heads” through the day, and sometimes given a sleeping place under the table when night comes on, and finds them unprovided with any other lodging. The natural excitement of the game is not sufficient for your Sharp; indeed you may detect him at once by his eagerness after the first game—which he is generally careful to lose—“to bet a dollar or so with you just to give the game an interest.” He is the particular friend of any one who will ask him to “take a drink,” and his duties to the house embrace the offices of lounge, runner, talker, player, sponge, shoulder-hitter, and referee.

last-named character he is particularly proud of: to him any question, upon almost any subject,

and he will attempt an answer, totally regardless of whether he ever in his life heard a word about the matter before, or not; and his peculiar hobby is to be called upon to decide disputed points in billiards—of which he considers himself the only recognized authority, and that his *ipse dixit* should be law.

He is also very fond of urging others to make bets. He knows more about the game, he says, than any other living man, and if he only had a little capital to back him—with *his* experience, a fortune might be made in a few days! Not, however, that he is destitute—far from it: if you judge him by his present appearance you will be most miserably sold: for he tells you that he has “been upon a spree,” but is now (and has been for some years, to our certain knowledge), in expectation of a remittance of a few thousand dollars or so from the governor, which will make all right. Or, perhaps he is an Englishman (according to his own account), just come into possession of an enormous fortune by the death of a wealthy relative in India: the fortune “that was to have arroven, has not yet arriv,” but the steamer is already some days overdue, and if you will just accommodate him in the meantime with the loan of one dollar (*five* if you look green, *fifty* if you are tipsy), you may rely upon it that he will repay you with interest an hundred-fold as soon as “that cussed steamer” has come in, and the first moiety of his estate is lodged in the hands of his family banker. So strong is the delusion which constant habit has imposed upon these miserables, that they feel quite offended if refused, and will

get angry if they see a chance: whereas, if a party, to get rid of their importunity, or as a punishment to himself for having descended to talk to one of such a tribe, flings them a dollar, or fifty cents, they feel none of the gratitude that such an act would inspire in the bosom of the common beggar, but attribute the success, which is really the result of disgust or weariness, to their own superior "smartness" and the stranger's imbecility. "I guess I was more than a match for that fellow," thinks the Sharp; "I talked him out of it—he couldn't resist me nohow:"—and the dollar so acquired is dearer to his diseased imagination than would be fifty times that sum, if gained in any honest way.

As we said before, he is fond of urging others to make bets—it being impossible for himself to do so, (though he would be sure to win,) until either the foreign steamer, or the remittance from the governor arrives. He is a matchmaker—yes sir-ee! and the best matchmaker to be found on the hither side of Jordan. Only let him tell you how to lay your wagers, and with whom, and you will be sure to win, for he is never mistaken. He tells A to bet against B, for that he can surely beat him; he is so sure of it, that he will go halves with A in the bet, though the loss, if lost, would strip him of his last red cent. To B he repeats the same story, and offers the same conditions. The match is made, we will suppose, and the Sharp is sure of his share, let who will come to the wall. When either party wins, he will slap him on the shoulder, and say—"There! didn't I tell you you could beat him?"

He coolly pockets his half of the winnings, and when the loser reminds him that he promised to share half the losses as well, he is suddenly seized with a great deafness, or remembers that he left his purse in the oyster shop below stairs, and must go look for it; or perhaps, if his victim does not look like a fighting-man, he tells him to "shut up," and that he will pay him either when the remittance comes to hand, or on the first Sunday that happens to fall in the middle of next week. Or perhaps he may condole with the loser: tell him the result has amazed him—that he never saw more beautiful play in his life than that made by his victim; that nothing but the irregularity of the balls or the falseness of the table could have defeated such really splendid play: and if "the flat" be verdant enough to accept this coin of flattery in lieu of the solid currency out of which he has been swindled, the Sharp will give him any quantity of it, and on the very lowest terms: "another drink" is all he charges for his half-hour's eulogy.

To these sources of profit, the Sharp adds that of runner and peripatetic blower to disreputable houses engaged in the manufacture of billiard tables. They supply him with clothes, to enable the fellow to mingle in respectable society, and allow him an enormous percentage for every billiard table sold to a stranger through his agency.

The Sharp, when engaged as "blower," has a double duty to perform; he is not only to puff up such houses as may have hired him, or with which he is on terms of agency; he must also pull down, as far as in him

lies, the reputation of such manufacturers as have the honesty to despise and scorn the means by which he earns his wretched and dishonorable livelihood.

Having said thus much of the genus—with the history and peculiarities of which we could fill a volume were we so disposed—it can scarcely be necessary to add that their habits are migratory and uncertain to the last degree. As soon as they have made “a hit” in one saloon, they dodge off to another, and thus go the rounds of the city until all the dens which harbor them are, in their own vernacular, “played out.” They then spread their wings for “fresh fields and pastures new,” and thus come back, after a lapse of some years, to the city from which they started, having suffered various degrees of ignominy and want in the course of their wanderings through other towns.

Avoid all such, ye novices; and should a stranger in a strange room ask you to play with him for any sum “just to give an interest to the game,” compare him mentally with the sketch here furnished, and if you find any definite resemblance, be careful to refuse.

LOVE GAME.—Is a condition in which novices will be very apt to find themselves, if they commence by challenging an experienced player.

COUNT.—Is the reckoning of the game. To make a count means, to make a stroke which will add some figures to your reckoning.

A TABLE OF THE MOTIVE POWERS

TO BE USED IN EXECUTING THE DIFFERENT PROBLEMS LAID DOWN
IN THE SUCCEEDING DIAGRAMS.

Previous to the author's former work on the game of billiards, no writer on the subject had ever attempted to lay down a scale of the different amounts of strength that would be required for the execution of the different strokes; and yet without some such scale, all written instructions might be compared to the play of Hamlet, with the prince's character omitted. Of what use can it be to tell the direction in which the cue-ball should be driven, and the point at which the object-ball should be struck, unless we can place a definite limit to the strength to be employed in the execution of the problem? For the angles will vary, as the strength is increased or diminished; and unless some graduated scale can be applied to every stroke, the instructions, so far as practical utility to the student is concerned, might as well be omitted altogether.

This subject was forced upon the author's notice when engaged in teaching the game, many years ago. His pupils used to complain, that though they made the force, or twist, or following strokes as directed, and struck the object-ball at the point laid down, the result did not answer their expectations, nor was it similar to the result of the same stroke when played by him.

What, then, could the tutor do? If he told them to play "a little harder," "a good deal harder," "a

great deal harder," "not quite so hard," "not half so hard," "twice as hard," "extremely hard,"—he found that these terms were indefinite, and that no two of them agreed in their interpretation. One of them, if told to play "a little harder," would drive his ball over the opposite cushion, and away to the far end of the room; while the same order, given to another, would not call forth the requisite amount of strength.

Under these circumstances, he found that the first step in tuition must be, to afford the novice an accurate idea of the different quantities of strength required for the execution of different strokes; the table of motive powers, illustrated in the diagram on page 75, was constructed, and each pupil had to practice until he could very nearly approximate the different strokes, as laid down under their respective numbers. This exercise will be found very serviceable to the student, not only for giving him an idea of the quantities of motive power, but also imparting general steadiness and certitude to his aim.

In this table the author has taken the amount of power requisite to propel a ball from the string to the opposite cushion, and thence back to the cushion behind the string, as the unit of his calculation. This power is marked as Quantity of Power, Number One or, for shortness sake, *Q. P.*, *No. 1.*

To propel it from the string to the opposite cushion, thence back to the cushion behind the string, and hence half way down the table, is marked as *Q. P.*,
2.

To propel it from the string to the opposite cushion,

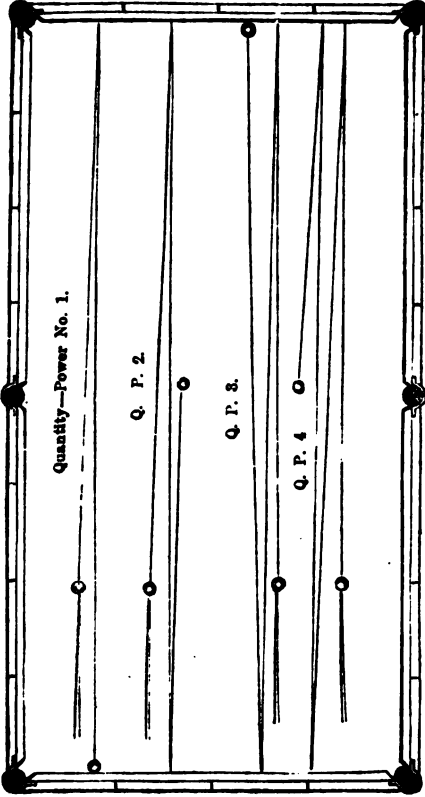

THE NEW YORK
PUBLIC LIBRARY.

ASTOR, LENOX AND
TILDEN FOUNDATIONS.

thence back to the cushion behind the string, and thence on to the cushion which it first struck, is *Q. P., No. 3.*

To propel it from the string to the opposite cushion, thence back to the cushion behind the string, thence back to the cushion it first struck, and thence half-way down the table, is marked as *Q. P., No. 4.*

These divisions will be found to answer the earliest requirements of the player. As he advances in the practice of the game, he will learn to graduate as far below *Q. P., No. 1*, as one-eighth of that power, which is ordinarily low enough for all practical purposes; from thence he can ascend, in the proportion of eighths, to *Q. P., No. 4*, beyond which it is almost impossible to retain the command of the balls with any certainty of aim.

Let it be borne in mind that great cue-strength is not produced by any violent muscular or bodily contortions; it depends far more on the looseness and quickness of the arm, and the jerk which is imparted by the wrist. The motion made, when striking with the cue, should be somewhat similar, in sudden quickness, to that made in throwing the lasso; and reference should here be made by the student to the instructions in Chapter III on this point, under the heading "Conditions of a good attitude."



THE NEW YORK
PUBLIC LIBRARY.
ASTOR, LENOX AND
TILDEN FOUNDATIONS.

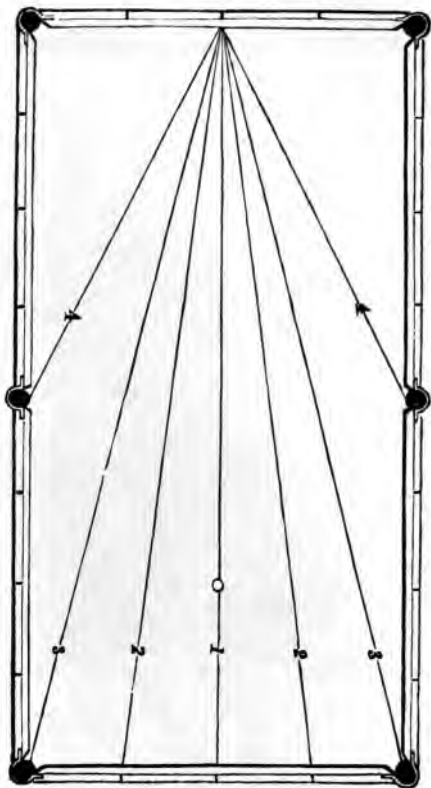

1
2
3

EXPLANATION OF DIAGRAM NO. I.

This diagram exhibits the simple angles produced by playing a ball with the different quantities of power hereafter set forth. For example: play from the Spot at the head of the table at the middle nail or sight opposite, with Q. P. No. 1, or upwards, and the ball, if struck fairly in the centre, will return over its original course, and hit the corresponding nail behind the Spot. [In this proposition, and in all others, we suppose the cushions to be correct, and the tables level.]

Again, play the ball from either of the points marked 2, with Q. P. 2 $\frac{1}{2}$, and it will return over the corresponding line at an angle of reflection equal to that of incidence.

Play from point 3, on a line between the centre of the lower corner pocket, and the nail at the bottom of the table, as marked, with Q. P. No. 3, and the ball will be returned at a similar angle into the opposite pocket. So also with point 4, played on a line between the middle pocket and nail with Q. P. No. 3 $\frac{1}{2}$.

It will be observed that the more obtuse the angle sought to be made, the greater quantity of power must be used to effect the object.

The student who desires to succeed should study this diagram carefully, and familiarize both his eye and hand with its practical execution. Let him practice it

as here laid down, and pay particular attention to the quantities of power required for the formation of different angles. This is a matter in which each must buy his own experience.

The diagram also exhibits the control which the player exercises over his ball by means of the twist or side stroke.

Playing always from the spot at the middle nail of the lower cushion, the ball can be brought back over the lines marked 2, 3, and 4, at each side of the spot from which it is played, according as it has been twisted to the right or left. The amount of the twist will depend upon the distance from its centre at which the cue-ball is struck, and the ability of the player to impart the peculiar motion necessary to effect such strokes. Considerable judgment is also required to graduate the proper quantity of strength. The rebound of the ball will incline to that side—whether left or right—on which the ball was struck.

For example: to cause your ball to return over line 2 to the right, strike it with Q. P. $1\frac{1}{2}$ a mere shade to the right of the centre.

To cause it to return over line 3, strike it with the same Q. P. $\frac{1}{4}$ R.

Over line 4, strike with Q. P. $2\frac{1}{2}$, $\frac{1}{4}$ R, $\frac{1}{4}$ B, or midway between the perpendicular and diagonal below. The tendency to rotate backward imparted by striking the ball below the centre, exhausts the progressive motion and favors the full development of the twist.

THE NEW YORK
PUBLIC LIBRARY.
ASTOR, LENOX AND
TILDEN FOUNDATIONS.

— — — —

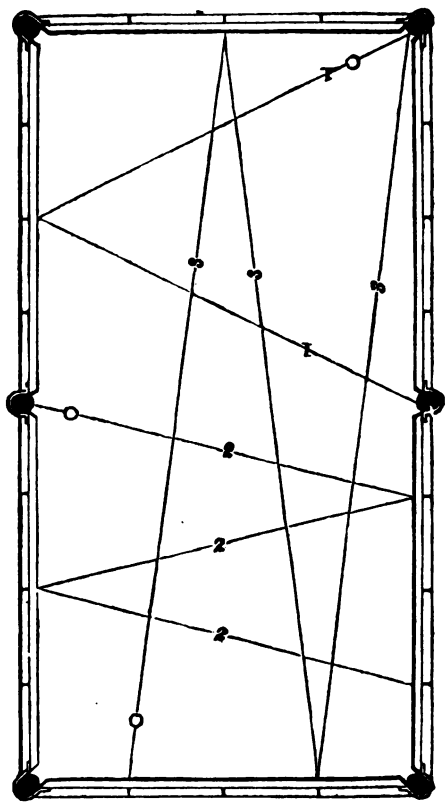

DIAGRAM NO. II.

Exhibits the same principle as the preceding one, with double or compound angles made. There can be no better test of the correctness of the cushions than a trial of these strokes. If the cushions are true, the ball, no matter how often doubled, will repeat its original angle at each fresh rebound. Thus, if stroke 2 had been played with increased power, the ball would have been pocketed in the left hand upper corner pocket—supposing, for the sake of argument, that cushions absolutely perfect could be found. Of course, however, nothing human is perfect; and the cushions most nearly approaching these requirements are the best.

The stroke marked 1, though the ball has there to travel over a shorter distance, requires to the full as much power as stroke 3, which moves over thrice the space. This is caused by the greater obtuseness of the angle made by 1. If stroke 1 were played with less power, the angle would be more obtuse.

THE NEW YORK
PUBLIC LIBRARY.

ASTOR, LENOX AND
TILDEN FOUNDATIONS.

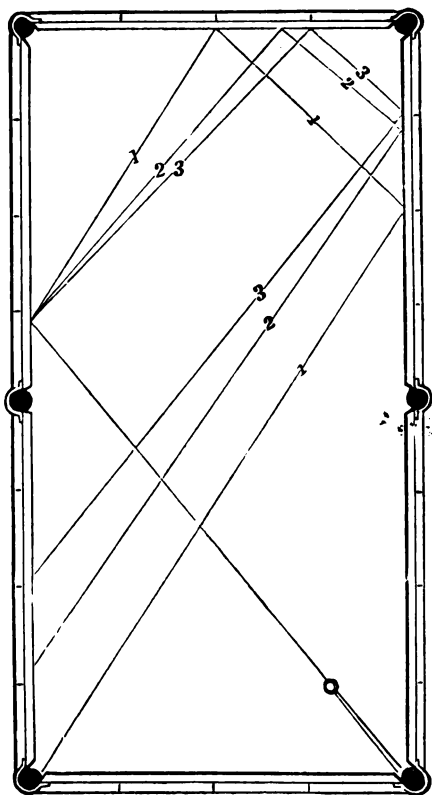

DIAGRAM NO. III.

Exhibits the different angles which will result from the same stroke when played with different amounts of force. For example: play from the position marked with Q. P. No. 2, and the ball after taking three cushions, as shown in the line marked 1, will be delivered into the opposite corner pocket.

Play the same stroke with Q. P. No. 3, and the increased strength will cause acuter angles, as shown in the lines marked 2. Increase the power still more, and the lines marked 3 will be given.

To account for these changes we must bear in mind that a change of axis takes place from the moment of contact with the first cushion, and is repeated as often as the ball strikes. This change of axis has no effect, however, until the ball comes in contact with the second cushion. The change which inclines the ball from a horizontal to a perpendicular axis, will be strong in proportion to the quantity of power used in play. When the ball is struck violently against the cushion, the cushion, as it were, grips its side, and sends it spinning forward with a stronger inclination to the perpendicular; this change causes the ball to be thrown back from the second and third cushions at angles of reflection more obtuse than those of incidence.

Supposing the ball to be struck fairly in its centre, its axis, up to the time of striking the first cushion, will be horizontal; the effect of contact is to incline this motion to change for one on a perpendicular axis; but the former impulse not having been entirely destroyed, there is a sort of compromise made between the conflicting inclinations, and a *diagonal* axis, the mean between the two, is evolved. This diagonal will incline more closely to the perpendicular, in proportion to the increase of power employed. But its angles will again be modified by its subsequent contact with cushions 2 and 3; and finally, as the strength becomes exhausted, the ball will again resume its horizontal axis in obedience to the laws of gravity and the friction of the table.

THE NEW YORK
PUBLIC LIBRARY.
ASTOR, LENOX AND
TILDEN FOUNDATIONS.

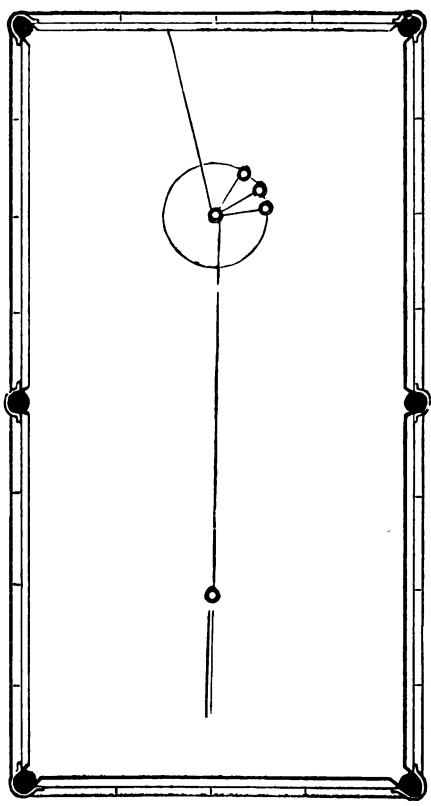

DIAGRAM NO. IV.

This diagram serves to show the effect of the different degrees of strength when two balls come in contact. For instance, play the cue-ball with Q. P. $\frac{1}{2}$, at the ball in the centre of the circle, full enough to make the latter travel over the line drawn from it to the cushion, and a carom on the ball at the lower section of the circle will be effected; increase that strength to Q. P. 2, and the carom on the ball next above it will be made; then try Q. P. $3\frac{1}{2}$, and a carom on the third ball will be effected. In playing these strokes, the cue-ball must be struck in the centre, and the object-ball each time in the particular place required to make it roll over the line which is continued to the lower cushion.

DIAGRAM NO. V.

Now that we have endeavored to explain the effect of the different quantities of power, we will attempt to point out the principles of a "Follow," and a "Force." Figure 1, in this diagram is intended to exemplify "the Force."

The intention of this stroke is to pocket ball 1, and carom upon ball 2. Play the cue-ball $\frac{1}{4}$ B, Q. P. 2, and strike the object ball $\frac{1}{4}$ R. For an explanation of the reason why the cue-ball rebounds to ball 2, see plate of cue-positions, stroke 2, marked "Force," with the remarks thereon.

Figure 2 shows the "Following-stroke," ball 1 being driven into the corner pocket, while a carom is effected upon ball 2. Strike the cue-ball $\frac{1}{4}$ A, with Q. P. $1\frac{1}{4}$. For further explanations, see same plate, (cue-positions,) stroke 3, with its accompanying explanations.

No. 5.

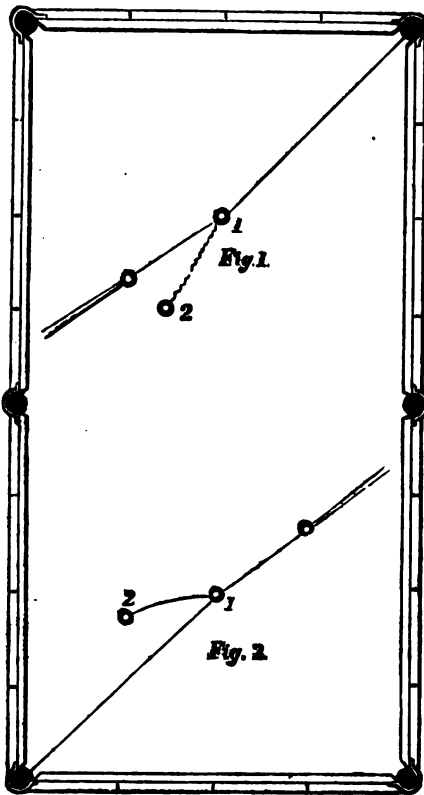

THE NEW YORK
PUBLIC LIBRARY.

ASTOR, LENOX AND
TILDEN FOUNDATIONS.

THE NEW YORK
PUBLIC LIBRARY.
ASTOR, LENOX AND
TILDEN FOUNDATIONS.

161232

No. 6.

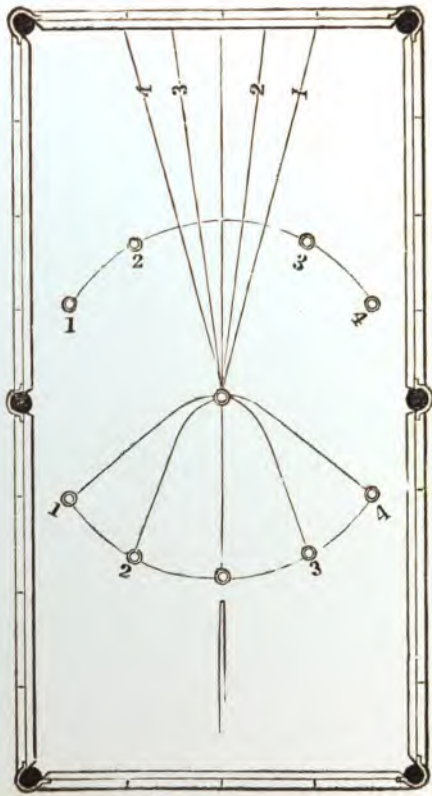

DIAGRAM NO. VI.

This plate is intended to further illustrate the "force" and "follow." The cue-ball is that at which the cue is pointed; the object-ball is that in the centre of the table; the balls marked 1, 2, 3, 4, are the ones to be caromed on; the lines marked 1, 2, 3, 4, show the course the object-ball will take when struck so as to make such caroms as represented on the balls of corresponding numbers. For example: to play so as to cause the cue-ball to follow on in a direct line after the object-ball; strike the object-ball dead full, the cue-ball to be struck exactly in the perpendicular central line, $\frac{1}{2}$ A, with Q. P. 1, or more, at the player's option. To effect a force in a straight line backwards to the place from whence the cue-ball started, strike the object-ball dead full, and the cue-ball $\frac{1}{2}$ to $\frac{1}{2}$ B, with Q. P. 2 $\frac{1}{2}$; giving it at the same time the peculiar motion referred to in the diagram of cue-positions, describing the "force."

To carom on ball 1 in the lower circle, strike the cue-ball $\frac{1}{2}$ A, with Q. P. 3, and the object-ball will take the direction of the line 1.

To effect a carom by a force on ball 1, of the upper circle, strike the cue-ball $\frac{1}{2}$ B, $\frac{1}{2}$ L, Q. P. 3, the object-

ability to use it, the result is as we see. Some of the very simplest shots are at variance with all the known rules of dynamics, and it would puzzle the most profound mathematician to account in theory for the effects which are practically illustrated by men not pretending to any scientific education whatsoever.

With these remarks we pass from the "following" and "forcing" shots, and speak of the effect of the "twist," or side-stroke, on the course of the cue-ball before striking a cushion.

THE NEW YORK
PUBLIC LIBRARY.
ASTOR, LENOX AND
TILDEN FOUNDATIONS.

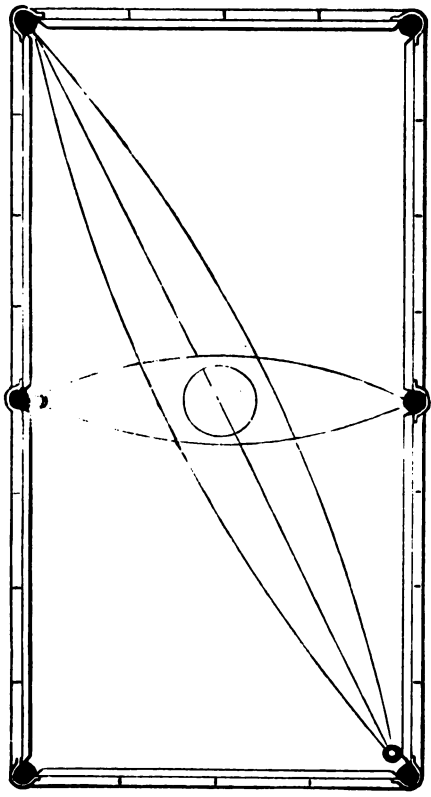

DIAGRAM NO. VII.

The circle in the centre represents a hat, a plate, or any object of similar magnitude placed there as an obstacle which the player's art is required to overcome.

The propositions—to play the ball from either side or corner pocket around the hat, and hole it in the corresponding pocket opposite—are identical in principle, though requiring a different elevation of the cue, and different varieties of power.

To effect the stroke from corner to corner, the cue must be elevated at an angle of at least 45 degrees, as shown in the position described as a Perpendicular Force (marked 5), on the diagram of cue-positions, in an earlier portion of this work. To make the ball curve round the hat, passing outside it to the right, from corner to corner,—strike it with the Perpendicular Force $\frac{1}{2}$ L, with Q. P. 2 to 3. Pay particular attention to the necessity for a quick, impulsive, lasso-throwing movement, as set forth in the instructions which are appended to the "force" (marked 2) in the aforesaid diagram.

To make the ball curve round the object to the left, strike with the same elevation and power, but change the $\frac{1}{2}$ L, to $\frac{1}{2}$ R.

To effect the stroke from the side-pocket, an eleva-

tion of five degrees more will be required; the Q. P. may be reduced to $2\frac{1}{2}$, or even a little less; but in proportion, as the strength and elevation are diminished, it becomes necessary to increase that peculiar lasso-motion to which we have before made reference.

In playing these and all other twisting shots, due allowance must be made for the curve before the player aims; or his ball will inevitably go wide of its mark, either to right or left. If the length of the shot is such that the curve will amount to a foot, then the player must aim a foot to the right or left of the point at which he really desires his ball to touch.

THE NEW YORK
PUBLIC LIBRARY.

ASTOR, LENOX AND
TILDEN FOUNDATIONS.

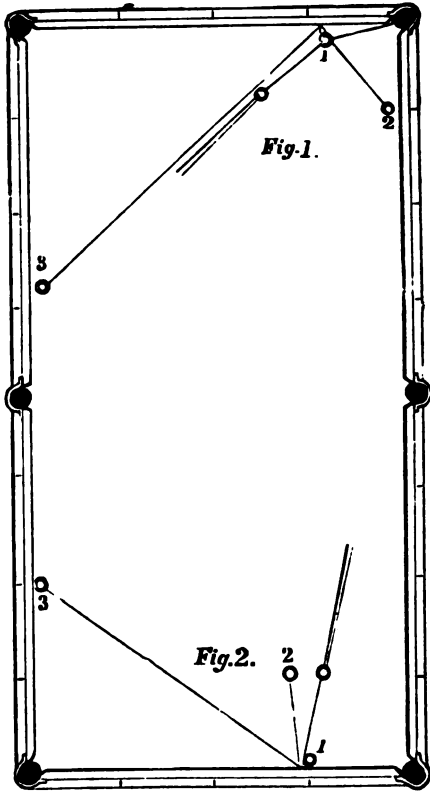

DIAGRAM NO VIII.

The purpose of this diagram is to show the effect the side-stroke will have on the cue-ball after contact with the cushion. Although the object-ball may be struck in the same place, the cue-ball can be made to take widely-different courses, as represented. The object in figure 1, is to pocket ball 1 in the corner pocket, and carom on ball 2 or 3. To effect the carom on ball 2, hit the object-ball where the line from the pocket would terminate were it continued directly through the centre of the ball. Strike the cue-ball $\frac{1}{2}$ R, on the horizontal central line, with Q. P. 1 $\frac{1}{2}$. To carom on ball 3, strike the cue-ball $\frac{1}{2}$ L, $\frac{1}{2}$ B, with Q. P. 2 $\frac{1}{2}$.

Figure 2.—To carom on ball 2, strike the object-ball fine, as represented in diagram, and the cue-ball $\frac{1}{2}$ L, $\frac{1}{2}$ B, with Q. P. 2 $\frac{1}{2}$. The object in striking the cue-ball below the centre in this stroke, is to communicate to it a motion similar to that in the forcing shot; such motion will have the effect of contracting the angle produced by the ball rebounding from the cushion.

To carom on ball 3, the object-ball is to be hit as in the preceding stroke. The cue-ball to be struck $\frac{1}{2}$ R, with Q. P. 1.

DIAGRAM NO. IX.

EFFECT OF THE SIDE STROKE AND TWIST CONTINUED.

Figure 1.—To play on ball 1, pocket it in corner, and carom on ball 2 or 3. To carom on ball 2, hit the object-ball so as to hole it, strike the cue-ball $\frac{1}{4}$ R, $\frac{1}{4}$ A, with Q. P. 2. To carom on ball 3, strike the object-ball $\frac{1}{2}$ L, $\frac{1}{8}$ A, with Q. P. $2\frac{1}{2}$.

Fig. 2.—To play on the ball on the spot, and pocket it in corner-pocket, and carom on balls 1, 2, 3, or 4: To effect the carom on ball 1, strike the cue-ball $\frac{1}{2}$ A, $\frac{1}{8}$ L, with Q. P. 3. To carom on ball 2, strike the cue-ball $\frac{1}{2}$ A, $\frac{1}{4}$ R, with Q. P. $2\frac{1}{2}$. To carom on ball 3, strike the cue-ball $\frac{1}{4}$ B, $\frac{1}{4}$ L, with Q. P. 3. To carom on ball 4, strike cue-ball $\frac{1}{2}$ B, $\frac{1}{8}$ L, with Q. P. 3.

No. 9.

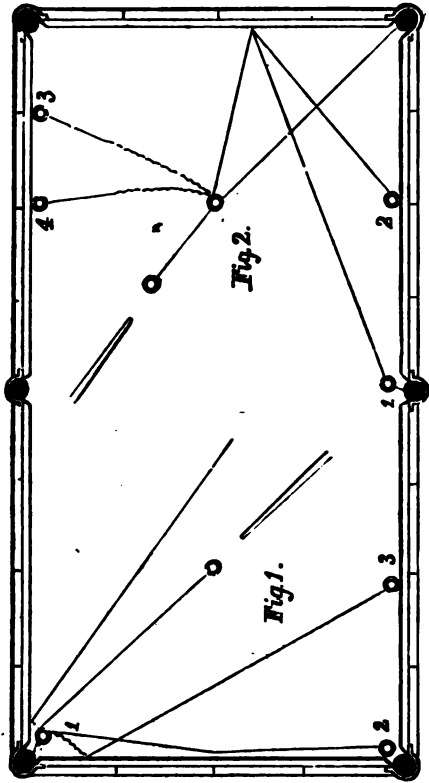

THE NEW YORK
PUBLIC LIBRARY.

ASTOR, LENOX AND
TILDEN FOUNDATIONS.

THE NEW YORK
PUBLIC LIBRARY.
ASTOR, LENOX AND
TILDEN FOUNDATIONS.

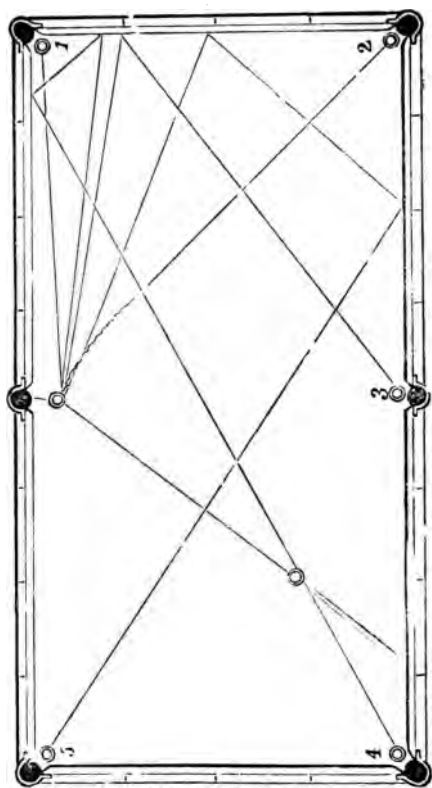

DIAGRAM. NO. X.

FURTHER ILLUSTRATION OF THE SIDE STROKE.

To play with the cue-ball and pocket the object-ball in the side pocket, and carom on balls 1, 2, 3, 4, or 5. To carom on ball 1, strike the cue-ball $\frac{1}{4}$ A, with Q. P. 1. To carom on ball 2, strike the cue-ball $\frac{1}{4}$ B, $\frac{1}{4}$ R, with Q. P. 2 $\frac{1}{2}$. To carom on ball 3, strike the cue-ball $\frac{1}{4}$ R, on horizontal line, with Q. P. 2 $\frac{1}{4}$. To carom on ball 4, strike the cue-ball $\frac{1}{4}$ A, $\frac{1}{4}$ L, with Q. P. 3. To carom on ball 5, strike the cue-ball $\frac{1}{4}$ R, $\frac{1}{4}$ B, with Q. P. 3 $\frac{1}{2}$. Thus, it may be perceived, that with the aid of the side-stroke and force, the cue-ball can be made to take almost any course the player desires. The object-ball is to be hit so as to hole it in the side-pocket, in each of these caroms.

DIAGRAM NO. XI.

ILLUSTRATIONS OF THE KISS AND SIDE STROKE.

To play on ball 1, and carom on balls 2, 3, 4, 5, 6, and 7. To carom on ball 2 by a kiss, strike the cue-ball $\frac{1}{2}$ A, $\frac{1}{4}$ L, with Q. P. $2\frac{1}{2}$, the object-ball to be hit $\frac{1}{4}$ R. To carom on ball 3, strike with same strength the object and cue-ball, hitting as above, only on the opposite side. To carom on ball 4, strike the cue-ball $\frac{1}{4}$ R, $\frac{1}{4}$ B, Q. P. $2\frac{1}{2}$, the object-ball to be hit fine on the left. To carom on ball 5, strike the cue-ball $\frac{1}{2}$ L, $\frac{1}{2}$ B, with Q. P. 3, the object-ball to be hit $\frac{2}{3}$ L. To carom on ball 6, strike the cue-ball $\frac{1}{4}$ R on the horizontal line with Q. P. 2, the object-ball fine to the right. To carom on ball 7, strike the cue-ball $\frac{1}{2}$ B, $\frac{1}{2}$ L, with Q. P. $3\frac{1}{2}$, the object-ball to be hit a half ball to the left.

No. 11.

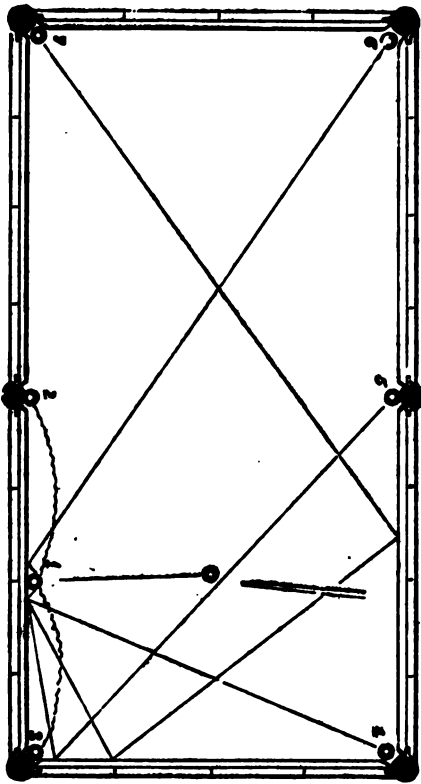

THE NEW YORK
PUBLIC LIBRARY.
ASTOR, LENOX AND
TILDEN FOUNDATIONS.

THE NEW YORK
PUBLIC LIBRARY.
ASTOR, LENOX AND
TILDEN FOUNDATIONS.

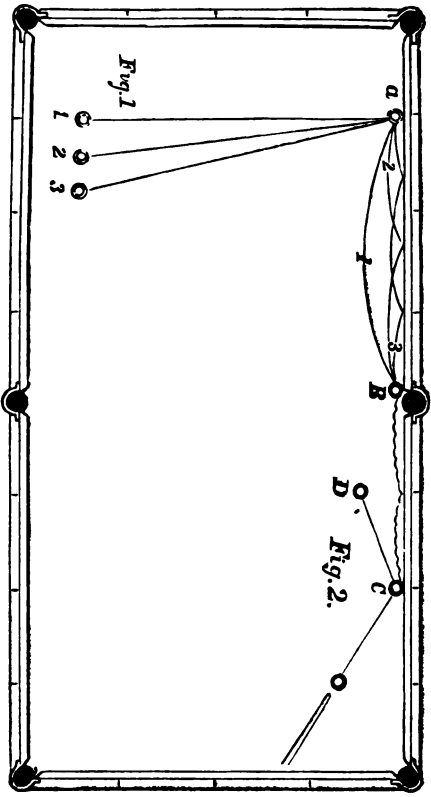

DIAGRAM NO. XII.

FURTHER ILLUSTRATIONS OF THE KISS AND SIDE STROKE.

EXPLANATION OF FIG. 1.—The three balls numbered 1, 2, and 3 in this figure, are intended to be the cue-balls, ball A the object-ball, and ball B the one to be caromed on; the lines marked 1, 2, and 3 the course the cue-balls will take, according to their respective numbers. For example, play with ball 1, from position as represented, with Q. P. $2\frac{1}{2}$, strike it $\frac{1}{2}$ A, the object-ball to be hit $\frac{1}{2}$ to the right, and the carom will be effected by the "kiss." Then again play with ball 2 with the same strength, strike it $\frac{1}{2}$ A, $\frac{1}{2}$ R, the object-ball to be hit $\frac{1}{2}$ R, and the carom will be effected by the cue-ball describing curves similar to those marked by line 2. Again, play with ball 3, strike it $\frac{1}{2}$ R, $\frac{1}{2}$ A, with Q. P. $3\frac{1}{2}$, and the carom on ball B will be effected by a sort of hugging tendency of the cue-ball, after forming curves similar to those represented by line 3.

The student should pay particular attention to this Figure, as there are certain principles represented by it, which will be very essential for him to have a knowledge of.

In all of these strokes the cue-ball has a following tendency, caused by the cue striking it above the centre, consequently it hugs the cushion. In No. 1

this tendency is effected by the simple stroke above the centre, but in Nos. 2 and 3 the cue-ball also requires striking to the right, as well as above the centre, owing to its relative position to the object-ball.

In No. 2, $\frac{1}{4}$ R is sufficient to effect this purpose, but in No. 3 the cue-ball must be struck $\frac{1}{2}$ R, in consequence of the greater acuteness of the angle formed by the lines drawn from it to the object-ball, and from the latter to ball B. If, in these two strokes, the cue-ball were struck to the left, it would either stop under the cushion, or take a direction to the left, the very opposite to that which the striker intended.

FIG. 2.—To play on ball C, and carom on ball D, strike the cue-ball $\frac{1}{4}$ L, with Q. P. 1, the object-ball to be hit dead full. To carom on ball B, hit the object-ball dead full; strike the cue-ball $\frac{1}{4}$ A, with Q. P. $2\frac{1}{2}$.

**THE NEW YORK
PUBLIC LIBRARY.**

**ASTOR, LENOX AND
TILDEN FOUNDATIONS.**

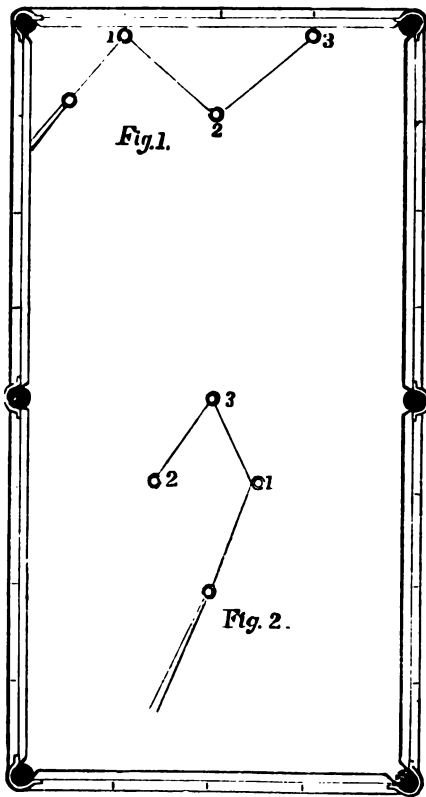

DIAGRAM NO. XIII.

FURTHER ILLUSTRATION OF THE KISS AND FORCE.

FIG. 1.—To play on ball 1, kiss on ball 2, and carom on ball 3. Hit the object-ball $\frac{1}{2}$ R, strike the cue-ball $\frac{1}{2}$ A, $\frac{1}{2}$ L, with Q. P. 2.

FIG. 2.—To play on ball 1, carom on ball 3, and, by a force, carom on ball 2. Strike the cue-ball $\frac{1}{2}$ B, $\frac{1}{2}$ R, with Q. P. 3 $\frac{1}{2}$, the object-ball to be hit fine on the left, as represented in diagram.

DIAGRAM NO. XIV.

MORE OF THE KISS.

To play on ball 1, and, by a kiss, carom on ball 2. Strike the cue-ball $\frac{1}{2}$ B, $\frac{1}{2}$ L, with Q. P. $3\frac{1}{2}$, the object-ball to be hit $\frac{1}{8}$ R.

The object of this diagram is to show the effect of a twist on the cushion. When played as represented, the cue-ball will be thrown off in a direction opposite to that it would have taken, had it hit the cushion where ball 1 is situated. The dotted line is intended to show the course the ball would have taken, had it been played without the "twist" or side-stroke.

THE NEW YORK
PUBLIC LIBRARY.

ASTOR, LENOX AND
TILDEN FOUNDATIONS.

THE NEW YORK
PUBLIC LIBRARY.
ASTOR, LENOX AND
TILDEN FOUNDATIONS.

No. 15.

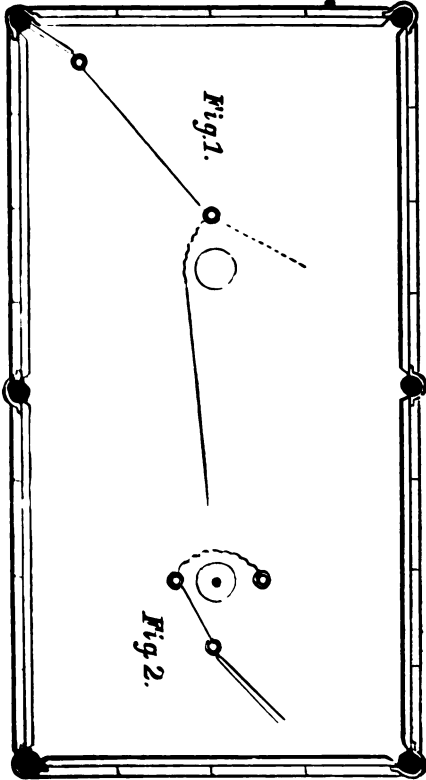

DIAGRAM NO. XV.

FORMING CURVES BY A FOLLOW AND A FORCE.

FIG. 1.—To place a ball upon each spot, and carom upon them by means of a follow, the cue-ball transcribing a curve around a hat, which occupies the position of the circle. Strike the cue-ball $\frac{1}{2}$ A, $\frac{1}{2}$ L, with Q. P. 8, the object-ball to be hit $\frac{1}{2}$ R, so that it shall take the direction of the dotted line.

FIG. 2.—To effect a carom with a force, the cue-ball transcribing a curve around a hat occupying the position of the circle. Strike the cue-ball $\frac{1}{2}$ B, $\frac{1}{2}$ L, with Q. P. $3\frac{1}{2}$, and the object-ball $\frac{1}{2}$ R. In effecting this stroke, the bridge and cue require to be somewhat elevated, to give a slight hop to the cue-ball.

DIAGRAM NO. XVI.

MANAGING THE BALLS SO AS TO LEAVE GOOD "BREAKS."

A perfect mastery of this art is probably the most important to the player, of all other branches of the science. After he has mastered the follow, the force and the twist, *skill, science, and judgment* combined are the three essentials for the student to acquire. For instance, the player may have a simple stroke, either a hazard or a carom, which, when effected, will leave the balls in a position where even an adept would find it difficult to count. There may, at the same time, be other strokes on the table less easy to effect, but which, if made, would leave the balls in a position favorable for a run; in such a case *judgment* would decide that the player should attempt the more difficult stroke, to avail himself of the prospective advantages which probably will result from it. *Judgment* makes the great difference between players—one exercising it frequently contending successfully against an opponent who is his superior in execution.

Strike the cue-ball $\frac{1}{2}$ B, $\frac{1}{3}$ L, with Q. P. $2\frac{1}{2}$, the object-ball to be hit so as to make it roll over the line, as represented, and the player will have a break of balls, which, with judicious management, will enable him to effect a long run.

No. 16.

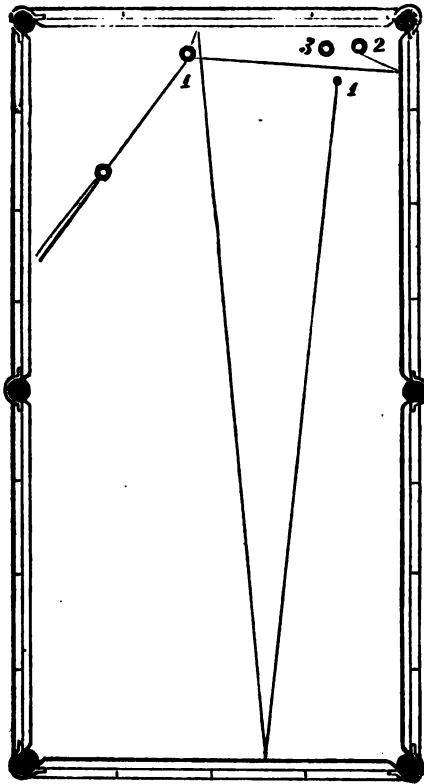

THE NEW YORK
PUBLIC LIBRARY.

ASTOR, LENOX AND
TILDEN FOUNDATIONS.

THE NEW YORK
PUBLIC LIBRARY.

ASTOR, LENOX AND
TILDEN FOUNDATIONS.

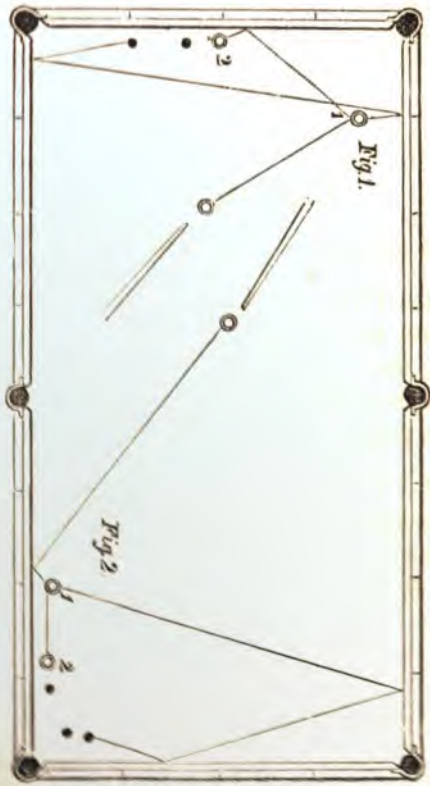

DIAGRAM NO. XVII.

ANOTHER ILLUSTRATION ON MANAGING OR NURSING THE BALLS.

FIG. 1.—To play on ball 1, and effect a carom, leaving a good break: strike the cue-ball $\frac{1}{2}$ B, $\frac{1}{2}$ L, with Q. P. $1\frac{1}{2}$, the object-ball to be hit so as to make it roll over the line, as marked, and the balls will approximate the positions designated by the black spots.

FIG. 2.—To effect a carom, and leave a break similar to that designated by the black spots: play the cue-ball, as represented, against the cushion, striking it $\frac{1}{2}$ L, with Q. P. $1\frac{1}{2}$.

DIAGRAM NO. XVIII.

FURTHER ILLUSTRATIONS ON NURSING OR MANAGING THE BALLS.

We will suppose the cue-ball to be in hand, and one of the balls a trifle out of the string, the other two in positions as designated. Here are three different positions represented by Nos. 1, 2, and 3, in either of which the cue-ball may be placed. To play from position marked 1, and force back as represented: strike the cue-ball $\frac{2}{3}$ B, $\frac{1}{4}$ L, with Q. P. $1\frac{1}{2}$, hitting the object-ball so that it rolls over and returns by line 1. Again, from position 2: strike the cue-ball $\frac{2}{3}$ B, $\frac{2}{3}$ L, with Q. P. 3, the object-ball to be hit so as to roll over line 2. From position 3: strike the cue-ball $\frac{1}{4}$ R, with Q. P. 2, the object-ball to be hit $\frac{2}{3}$ R, so as to make it roll over line 4; and the presumption is, that good breaks will be the result of each stroke.

**THE NEW YORK
PUBLIC LIBRARY.**

**ASTOR, LENOX AND
TILDEN FOUNDATIONS.**

THE NEW YORK
PUBLIC LIBRARY.
ASTOR, LENOX AND
TILDEN FOUNDATIONS.

THE NEW YORK
PUBLIC LIBRARY.

ASTOR, LENOX AND
TILDEN FOUNDATIONS.

FIG. 10.

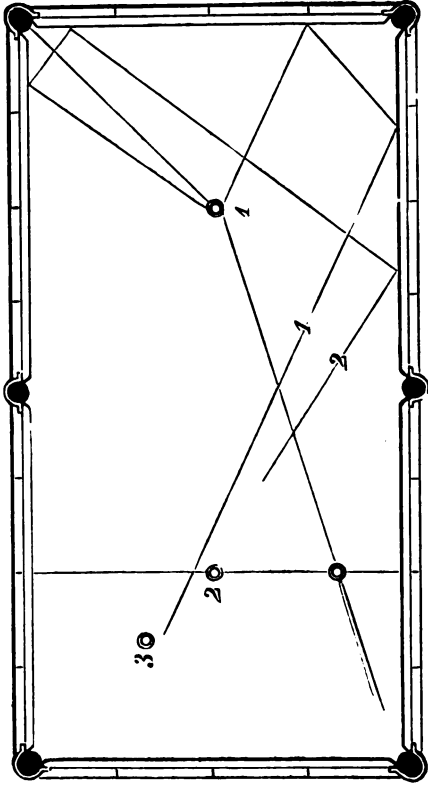

DIAGRAM NO. XIX.

TAKING ADVANTAGE OF THE CHANCES FOR MAKING POINTS.

In playing billiards we frequently find the balls in a position where a count can be effected in several different ways. In such cases, it is advisable for the player to take into consideration the probabilities of effecting the stroke, and the position of the balls thereafter. If the stroke be at all doubtful, he should play where he would have the greatest prospect of success, or, in other words, "take the chances."

We will again suppose the cue-ball to be in hand, and the player wishing to secure a good break. If he is playing the usual game, it would be advisable for him to play on the object-ball, so as to pocket it and return over line 1, in this way taking three chances to make a count. If he is playing caroms alone, it would be better for him to play on the left of the object-ball, so as to draw it back in the string, as near the other balls as possible. To make the first stroke: strike the cue-ball $\frac{1}{4}$ A, $\frac{1}{4}$ R, with Q. P. $2\frac{1}{2}$, and if the object-ball be pocketed in the corner, as represented, the carom will be made on one of the balls numbered 2 and 3. To make the second stroke: strike the cue-ball $\frac{1}{4}$ A, $\frac{1}{4}$ R, with Q. P. $2\frac{1}{2}$, the object-ball to be hit $\frac{2}{3}$ L.

THE NEW YORK
PUBLIC LIBRARY.

ASTOR, LENOX AND
TILDEN FOUNDATIONS.

No. 20.

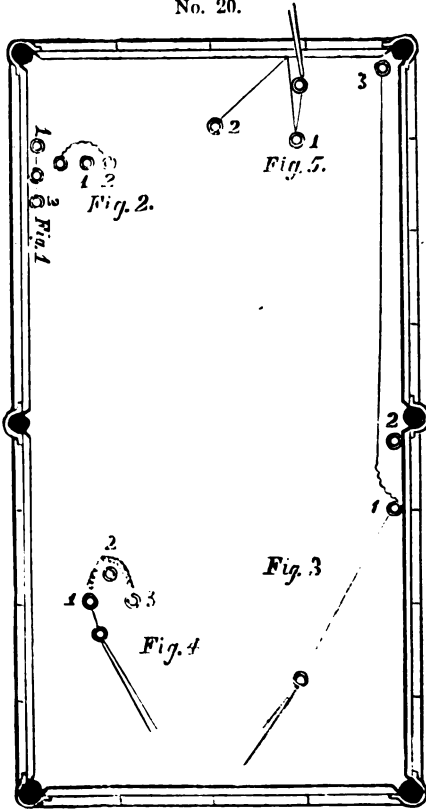

DIAGRAM NO. XX.

SOME FANCY SHOTS IN COMMON USE.

We have hitherto confined our attention to the illustration of what may be called the regular game, and the explanation of those principles which are essential even to common proficiency; we did so, lest the student should embarrass his first efforts with attempting strokes beyond his skill.

In the above diagram we have set forth a few of the fancy shots, now in very general use, and proposed among good players as a test of peculiar skill. In certain positions of the game, the adept will find them do good service; but we must still caution the novice that the penalty, should he attempt them, will very likely be a rupture of the cloth. It is almost impossible to give an exact verbal description of these strokes; and players who aspire to make them, should put themselves, for a day at least, under the tuition of a competent instructor; it would be cheaper to pay him five dollars for an hour's instruction, and then be master of the art, than have to pay thirty dollars for a new cloth, and still remain ignorant of what had caused the mistake.

FIG. 1.—To play on ball 1, and, by a perpendicular force, bring back the cue-ball so as to carom on ball 2: the cue-ball is the central one in this figure. The cue should be elevated, as marked in the plate of cue po-

sitions, to an angle of at least forty-five degrees; the cue-ball should be struck as marked and described in said plate, with Q. P. 2—the object-ball to be struck dead full.

FIG. 2—Is another perpendicular force, the object being to carom on balls 1 and 2, as represented. Elevate the cue, as before, and take aim for that part of the indented line where the curve first begins to act; strike the cue-ball $\frac{1}{8}$ R, with Q. P. $2\frac{1}{2}$.

These strokes are particularly needed in playing the French carom game, and are much practiced by the eminent players of France. Their usual game having no hazards in it, they excel in caroms, on the principle that makes a blind man's sense of touch so much more exquisite than the same sense in persons who can both see and feel;—so masterly is their execution of these particular forces, that were we to delineate some of the shots which we have seen them make, and made ourselves under their instructions, the reader would be inclined to suspect us of pushing his credulity too far. For our own part, we profess no peculiar expertness in these strokes—at least none that M. Berger would consider wonderful; for the nature of our game does not so frequently call for them. The novice must be careful to arrest his cue after the stroke is delivered, for otherwise the cloth may suffer; this is all the more difficult from the quickness, vigor, and vivacity which the stroke imperatively demands. The remaining problems are less difficult.

FIG. 3.—To play on ball 1, and by a curve to clear ball 2, and carom on ball 3. Strike the cue-ball $\frac{1}{4}$ A, $\frac{1}{4}$ R, with Q. P. $3\frac{1}{2}$; the object-ball must be struck $\frac{1}{8}$ R.

FIG. 4—Is to play on ball 1, and, by a curve which shall clear ball 2, to carom back on ball 3: to do this, strike the cue-ball $\frac{1}{4}$ B, $\frac{1}{4}$ L, with Q. P. $3\frac{1}{2}$, the cue to be elevated at an angle of not more than thirty degrees. This degree of elevation will give a combination of the "jump" and "perpendicular force" strokes, marked in the plate of cue positions, without which the stroke could not be made. The jump will cause the cue-ball to advance beyond ball 2, because its retrograding motion cannot come into play, until after its contact with the table; as soon as the friction begins to act against the retrograding tendency (*i. e.*, after it has jumped beyond ball 2), it will then recede, in a curve, as marked, and strike ball 3. Mr. J. N. White, of Philadelphia, particularly excels in this shot.

FIG. 5—Is intended to show the effect of the side-stroke and force, on the angle which the cue-ball will make after coming in contact with the cushion, the object-ball being previously struck. Strike the cue-ball $\frac{1}{4}$ B, $\frac{1}{4}$ L, with Q. P. $3\frac{1}{2}$, so as to strike the object-ball dead full. The cue-ball will return to the cushion, and fly off at the angle marked; which angle will be obtuser, and made on the opposite side to what it would have been, had not the cue-ball touched the object-ball but continued on to the end cushion opposite.

THE NEW YORK
PUBLIC LIBRARY.
ASTOR, LENOX AND
TILDEN FOUNDATIONS.

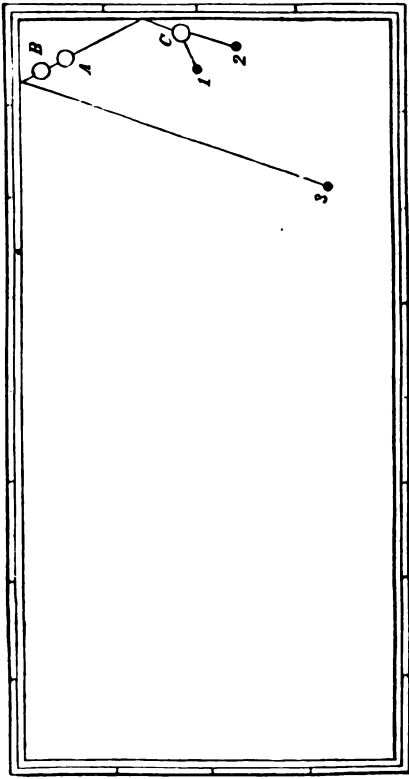

DIAGRAM NO. XXI.

This diagram is introduced to show the advantage which may inure to the player, by possessing the ability to execute perpendicular strokes. This position of the balls actually occurred in a match played in San Francisco, between the author and a celebrated French player, where the reputation of both players was at stake. The game was the French three-ball carom game, in which no pushing shots are permitted. The parties were playing 100 points up, the Frenchman having but three points to make, while the writer required twenty-one to win the game. Such were the conditions of the game when the position of the balls, as shown in the diagram, presented itself; and the author, playing a perpendicular stroke, effected a carom, from which he secured a run of nine, and eventually won the game. A represents the striker's ball, C that of his opponent, and B the red ball. The small dots show the relative positions of the balls, after the stroke was effected—No. 1 being the striker's ball, 3 the red, and 2 the opponent's ball.

DIAGRAM NO. XXII.

The diagram is intended to illustrate both execution and judgment. This position of the balls also occurred in the match referred to in the description of the preceding diagram, and was the game-shot of the rubber. It would have been a much simpler method of making the stroke for the author to have played upon No. 2, than taken the side-cushion and caromed directly upon No. 3. But, in case the stroke had been unsuccessful, the balls would have been left in a favorable position for the opponent. It must be recollected that the French three-ball carom game is as much a game of defence as attack; hence, safety is an essential element, to which the player must direct his attention. No. 1 represents the striker's ball, No. 2 that of his opponent, and 3 the red ball; hence, it will be readily seen that the striker, by playing the shot as represented in the diagram, would have left the balls in a much safer position had he proved unsuccessful, than would have been the case had he failed in making the simpler carom.

No. 22.

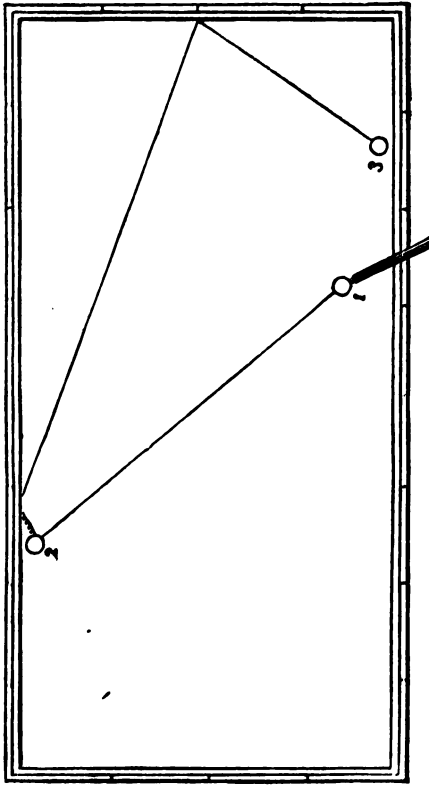

THE NEW YORK
PUBLIC LIBRARY
ASTOR, LENOX AND
TILDEN FOUNDATIONS.

THE NEW YORK
PUBLIC LIBRARY.

ASTOR, LENOX AND
TILDEN FOUNDATIONS.

No. 23.

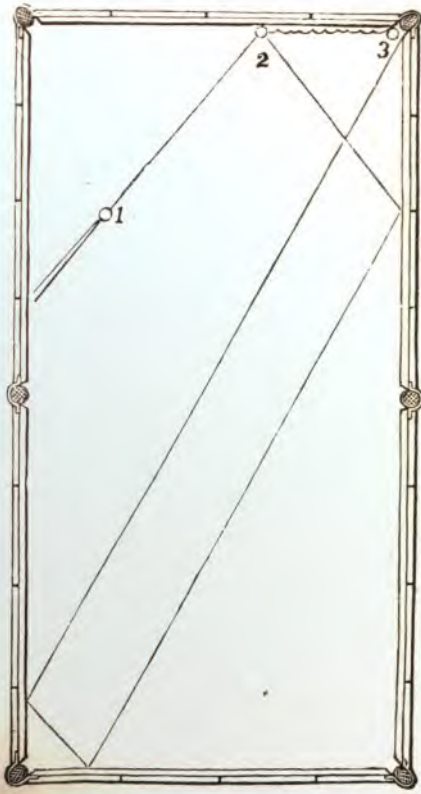

DIAGRAM NO. XXIII.

The shot, as represented in the diagram, is to play with ball No. 1, effecting a carom on balls 2 and 3, and pocketing balls 2 and 3 in the corner where ball 3 is represented.

To effect this shot play on ball 2 dead full, with strength enough to make it travel over the space covered by the line, as laid down in the diagram. Strike the cue-ball about $\frac{1}{2}$ A, $\frac{1}{4}$ R, with Q. P. $3\frac{1}{2}$ to 4, and it will hug the cushion as represented, and carom on ball 3 and pocket it. The twist communicated to the cue-ball will then act on the side-cushion, and cause it to roll out of the way ere ball 2 reaches its place of destination.

This proposition will not be new to any readers of the *Billiard Cue*, to which paper it was originally contributed by the writer. It seems simple now, when the lines are drawn which illustrate it; but as the proposition first appeared—the position of the balls being only indicated, and not the method of effecting the shot—many attempts were made, before the stroke was finally accomplished by one of our most distinguished amateurs.

DIAGRAM NO. XXIV.

This diagram shows a favorite stroke of Mr. C. Bird, of Philadelphia, who is frequently requested by his friends to make it. The object is to take six cushions, and effect the carom on balls 1 and 2, as represented.

Strike the cue-ball $\frac{3}{4}$ L, with Q. P. $3\frac{1}{2}$ to 4, the object-ball to be hit fine on the right.

No. 24.

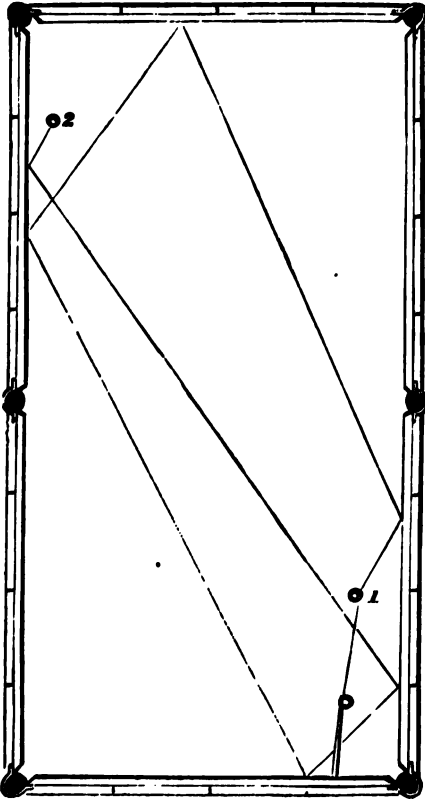

THE NEW YORK
PUBLIC LIBRARY,
AGTOR, LENOX AND
TILDEN FOUNDATIONS.

THE NEW YORK
PUBLIC LIBRARY.
ASTOR, LENOX AND
TILDEN FOUNDATIONS.

No. 2b.



DIAGRAM NO. XXV.

The letters A, B, C, and D, on the diagram opposite, show the position of the *Spots* on the billiard table. In placing them, a line is drawn down the centre of the table, from the centre nails or sights in the *head* and *lower* cushions; another line is then drawn from the centre sights in the *side* cushions, across the table, and where the lines intersect, the spots are placed. The spot at A, being next the *head* of the table, is the light red spot, and an imaginary line across the table at this point is the *string*; the spot at B is the dark red spot.

The spot at C is the English spot, which is to be thirteen inches from the *end* or lower cushion, and is used in playing the English game, but in this country it is generally put about nine inches from the lower cushion.

The spot at D is for two ball pool, and is placed about five inches from the lower cushion.

E shows the Pin Pool spots, that in the centre being number five; each of the others should be placed about $2\frac{1}{2}$ inches from it, in the position represented on diagram.

F shows the position of the balls in playing fifteen ball pool. The balls are placed in a triangular frame,

so as to insure exactness—the base of the triangle being parallel with the end, or lower cushion of the table. The highest number, fifteen, should be placed on the deep red spot, at B.

Figures 1 and 2 show the positions of the semicircles, or playing points, for the English and French games.

In playing the English game, the semicircle is drawn from the light red spot, with a radius of ten inches. In England the spot is placed two feet six inches from the cushion.

The semicircle for the French game is drawn with a radius of four and a half inches on the French table, but on the American full-sized table, it should have a radius of five inches.

CHAPTER V.

A CODE TO REGULATE AND REDUCE TO UNIFORMITY THE DIFFERENT GAMES OF BILLIARDS, AS PLAYED IN THE UNITED STATES AND ELSEWHERE.

To establish such a billiard-code as would meet with the general approbation and consent of billiard-players in all parts of the Union, would indeed be "a consummation most devoutly to be wished"—a consummation, also, more to be prayed for than expected.

In things the most trivial, as in things the most grave, it is difficult to make any large majority of men view any matter in precisely the same light. Some are prejudiced to this side, and others have their early convictions inclining them to that. All may deplore the disagreement—all may sigh for a uniformity of system; but few are prepared to abandon their peculiar ideas, without the sacrifice of which no uniformity can be attained.

In the rules laid down for playing the various games of billiards, this evil has been further aggravated by the petty jealousies of those engaged in the billiard business. Each one establishes a code of regulations for himself—a code in which it would appear to be his object to differ as much as possible from the codes

adopted by the other brethren of his profession. Certain manufacturers of *quasi* billiard tables, not knowing anything of the game themselves, and therefore not being competent to decide which of these conflicting codes is correct, pick out whichever one comes readiest to hand, and accompany the sale of everything they call a table with a framed and printed copy of this "code." In this way the country is flooded with conflicting rules, which frequently cause disputes that might otherwise be avoided.

"Let the cobbler stick to his last," is a maxim of great wisdom and antiquity; and one would really think, according to recent developments, that these "manufacturers" might find employment for some time further in attempting to improve the cushions and other parts of their table gear, which are notoriously defective and condemned. As a general rule, they are ignorant of the game, and opposed to any innovation in its mechanical appliances, even though the innovation contains the most important improvement. Their ignorance we account for on the same principle that is said to make "the confectioner less fond of sweetmeats than any man in the parish." From the hour of their apprenticeship they look upon the table as the object of their labor and the means of obtaining bread. They never associate the board with any sensations of amusement; and when in search of pleasure, they will seek it in whatever game can least bind them of their toil. That they should be opposed to innovations is extremely natural, therefore that they take no individual interest in the

science of the game, and that every alteration requires so much more time and trouble, and throws them so much out from the mill-horse round in which they have been accustomed to *proceed* without *progressing*.

In drawing up the following rules, the author hopes they are such as may meet with general adoption. He has practiced what he preaches in the forepart of this article, and sacrificed such of his private opinions as he found to be at variance with the customs most in vogue. He has seen differences arise and lead to angry words, in cases where both players were correct, according to the codes in use in the different sections from which each came. They met perhaps on "neutral ground" —in a city where the code was entirely different from that professed by either; and who could then determine from which side the concession should be made?

In the sincere hope of obviating these difficulties for the future, the author has compiled this code, with a view to its general adoption as the standard law; and to prove that he is actuated by a sincere desire for uniformity, and not by any vain conceit that his standing as a billiard-player is such as to make his *ipse dixit* be received as incontrovertible, he hereby promises to be governed by any other code which a convention of billiard-players, from the different sections of the Union, may be induced to agree upon.

He flatters himself that he has already done enough for the game of billiards, to guarantee that he has the development of its scientific principles sincerely at heart: his improvements in the tables and cushions, more especially, were not made without the sacrifice

of much time and money. The latter has been amply, and more than amply repaid to him by the generous appreciation which the billiard-playing public have bestowed on the result of his labors: but it would require something more than money to compensate either himself or his friends for the bitterness of calumny with which those who are naturally opposed to *all* innovations, as afore-mentioned, have since pursued both the inventions and inventor.

It would, indeed, be a much desired result, should these rules be universally adopted.

A CODE TO REGULATE THE AMERICAN, OR FOUR-BALL GAME.

RULE I.

ON STRINGING FOR THE LEAD.

Whoever, playing from within the *string* against the lower cushion, can bring his ball nearest to the cushion at which he stands, is entitled to the choice of lead and balls. Provided,

1st. That the player's ball, in stringing, has not touched any other ball upon the table ;

2d. Nor fallen into any of the pockets ; in either case he loses the choice.

RULE II.

ON LEADING.

1st. In leading, the player's ball must be played with sufficient strength to pass below the deep-red ball, or he loses his choice.

2d. It must not be played with so much strength as to repass the deep-red ball a second time, after having rebounded from the foot of the table. In this latter case, it is optional with the adversary to make the player spot his ball on the *pool spot*, play it over again, or take the lead himself.

RULE III.

ON THE OPENING OF THE GAME.

Once the lead is made, the game is considered as commenced, and neither player can withdraw except under the circumstances hereafter specified. But no count or forfeiture can be made until each player has played one stroke.

RULE IV.

ON FOUL STROKES.

The penalty for a foul stroke is this: that the player cannot count any points he may have made by

such stroke, and that his adversary is entitled to the next play. The following are among the strokes called foul :

1st. If either player use his opponent's ball to play with, the stroke is foul ; and, if successful, he cannot count, provided the error is found out before a second shot is made. But,

2d. Should two or more strokes have been made previous to the discovery, the reckoning cannot be disturbed, and the player may continue his game with the same ball. And,

3d. If it be found that the players have changed balls during the game, and if the change can be brought home to neither in particular, each must keep the ball he has, and let the game proceed.

4th. Should both the white balls be off the table together, and should either player, by mistake, pick up the wrong one and play with it, the stroke must stand, and he can count whatever he has made. [The reason of this is obvious ; for both balls being in hand and having alike to play from any point within the string, no possible advantage could arise from using the other's ball. Whereas, when the balls are on the table, the case is totally different ; for your opponent's ball might be advantageously placed, while your own was directly reverse.]

5th. If the striker aim at a ball before it is fully at

rest, or while any other ball is rolling on the table, the stroke is foul and no count can be effected.

6th. If, when in the act of taking aim, a player should touch the ball more than once with his cue, the stroke is considered foul.

7th. If the player, when pushing his own ball forward with the butt of his cue, does not withdraw the butt before the cue-ball touches the object-ball, the stroke is foul.

8th. If, when a red ball is holed, or forced off the table, the striker, before playing, does not see that said red ball is replaced upon its proper spot—supposing such spot to be unoccupied—the stroke he may make, while the red is not in its proper place, is foul. But should the spot be covered by any other ball, when the red is pocketed or forced off, the red must remain off the table until its proper position is vacant, and all the balls cease rolling.

9th. If, when the player's ball is in hand, he does not cause it to pass outside the string, before touching any of the object-balls or cushion (except in a case mentioned in the following rule), the stroke is foul, and his opponent may choose whether he will play with the balls as they are, have them replaced in their original positions, or cause the stroke to be played over a second time; or, should the player make a losing hazard under such circumstances, the penalty may be enforced.

10th. Playing at a ball whose base, or point of contact with the table, is outside of the string, is considered playing out of the string; and the stroke is a fair one, even though the side which the cue-ball strikes is hanging over, and therefore within the string.

11th. If, after making a successful stroke, the player obstructs the free course of the balls upon the table, he becomes subject to the penalties of a foul stroke, and cannot score his points.

12th. If the player, with his ball in hand, play at an object-ball that is exactly on the string, the stroke is foul; for a ball *on* the string must be treated as if within it.

13th. If the striker, through stretching forward or otherwise, has not at least one foot on the floor while striking, the shot is foul, and no points can be reckoned.

14th. If a player shall alter the stroke he is about to make, at the suggestion of any party in the room—even if it be at the suggestion of his partner in a double match, except where a special agreement is made that partners may advise—the altered stroke which he plays is foul, and he cannot count any points that may be won thereby.

RULE V.

ON FORFEITURES.

1st. If the player fails to hit any of the balls upon the table with his own ball, he forfeits *one*, which must be added to his adversary's count.

2d. The player forfeits *two* when his own ball is pocketed, after having touched a white one, and this totally irrespective of its having touched one or both of the reds.

But there is one case connected with the lead, in which a person can lose three even after touching the white—to wit: when he first strikes the red, and then pockets himself off his opponents ball. In all other cases, he can only lose two, when his own ball shall have touched his opponent's before going into the pocket. The additional penalty of one in this case is exacted for having first touched the red.

3d. He forfeits two to his opponent, also, when he causes his ball to jump off the table or lodge on the top of the cushion, after having touched his opponent's ball.

4th. When his own ball is pocketed, or jumps off the table, or lodges on the cushion, as before described, without either having touched any ball at all, or having only touched one or more red ones, the player forfeits three.

*

[In and around New York, three is the highest number that a player can be mulcted in for any single stroke; but, in some other parts of the Union, they add to this forfeiture any number of points which he may otherwise have made by the stroke. Surely the penalty of three, and to lose his count and hand, ought to be enough to satisfy a Shylock.]

5th. If the player cause any ball to jump off the table, and should it, by striking against any of the by-standers, be flung back upon the board, it must still be looked upon and treated as if it had fallen to the floor. If a red ball, it must be spotted; if a white one, held in hand; and if it be the cue-ball, the player shall forfeit two or three to his opponent, conformably to the terms laid down in the two preceding paragraphs.

6th. Though the striker, when playing with the wrong ball, cannot count what points he may make, except in those cases mentioned in the second, third and fourth paragraphs of Rule IV.; nevertheless, whatever forfeitures he may incur while playing with the wrong ball, he is bound to pay, as if he had been playing with his own.

7th. Any player who has commenced a game, as d in Rule II., must either finish or forfeit it, under the circumstances particularly set forth VII.

RULE VI.

ON CASES WHERE THE BALLS ARE IN CONTACT

According to the old rule observed in New York, if the cue ball were in actual contact with any other, no count could be made by the player under any circumstances, though he would be obliged to strike and separate the balls at least one inch. This rule was manifestly unjust, and its injustice heightened by the fact that while the player *could not* win, he could lose as in common cases, should he either pocket his own ball, cause it to jump off the table or lodge on the cushion. Unjust in itself and different from the practice in most other places, it was further aggravated by the difficulty recently experienced of finding balls of well-seasoned ivory,—almost all new balls being incorrect from shrinkage after a little use, and therefore apt to fall together from no want of skill on the player's part.

For these considerations therefore, and in obedience to the wish repeatedly expressed by players in this city and from all parts of the country, we think it would be better to make the rule on the subject read thus :

1st. When the cue-ball is in contact with any other, the player can make no count unless he first plays against some other ball with which his own was not in contact. But a count can be made on the ball with

which his own was in contact, provided he shall have first played on any other ball on the board.

2d. This stipulation observed, the play can then be pursued entirely as if the balls had not been in contact.

RULE VII.

ON WITHDRAWING FROM, WITHOUT FINISHING A GAME.

1st. The player may protest against his adversary's standing in front of him, or in such close proximity as to disarrange his aim.

2d. Also, against loud talking, or any other annoyance by his opponent, while he is making his play.

3d. Also, against being refused the use of the bridge, or any other of the instruments used in that room in playing, except where a special stipulation to the contrary was made before commencing the game.

4th. Or in case his adversary shall refuse to abide by the marker's, or company's decision, on a disputed point, which it was agreed between them to submit to the marker, or company, for arbitration; in any one, or all of the foregoing cases, if the discourtesy be per-

sisted in, the party aggrieved is at liberty to withdraw, and the game shall be considered as drawn, and any stakes which may have been depending on such, must be returned.

5th. Should the interruption or annoyance have been accidental, the marker, if so requested by the player, who is entitled to repeat his stroke, must replace the balls as near as possible in the position they occupied before the player made the stroke in which he was interrupted.

RULE VIII.

ON CASES IN WHICH THE MARKER MUST REPLACE THE BALLS, IF CALLED ON, AS NEARLY AS POSSIBLE IN THEIR FORMER POSITION.

1st. In the case mentioned in the 5th paragraph of preceding rule.

2d. Where any of the balls when at rest are moved by accident.

3d. Where any of the balls while rolling, are suddenly obstructed, either by accident or design. In this case the marker, if so requested by the players, shall place the interrupted ball as nearly as possible in the situation which it would apparently have occupied had it not been stopped.

4th. Where the cue-ball, resting on the edge of a

pocket, drops into it, before the striker has time to play.

5th. Where the object-ball, in a similar position, is rolled back into the pocket by any of the ordinary vibrations of the table or atmosphere.

6th. In all cases aforementioned, where it is specified that in consequence of a foul stroke, the player's opponent shall have the option, either of playing at balls as they are, or causing them to be replaced by the marker.

7th. When either or both of the red balls are pocketed, or forced off the table, it is the marker's duty to spot them before another stroke is played—except the spot appropriate to either be occupied by one of the playing balls, in which case the red one must be kept in hand until its position is uncovered.

8th. If, after playing a ball, the player should attempt to obstruct or accelerate its progress by striking it again, blowing at it, or any other means, his opponent may either play at the balls as they stand, or call upon the marker to replace them in the position they would otherwise have occupied.

9th. If the striker, in the act of taking aim, or otherwise, move his ball ever so little, it is a stroke; and should he strike the ball again, his opponent has the option as in the preceding paragraph.

RULE IX.

ON THE DUTY OF PLAYERS TO EACH OTHER.

1st. Each player must look after his own interest, and exercise his own discretion. His opponent can not be called on to answer such questions as "Is the ball outside or inside the string?" "Are the balls in contact?" and so forth. These are questions for the player's own judgment to decide.

2d. Each player should attend strictly to his own game, and never interfere with his adversary's, except when a foul stroke or some other violation of these rules may call for forfeiture.

RULE X.

ON THE DUTY OF THE MARKER, AND THE SPECTATORS, TO THE PLAYERS.

1st. In a single game, no one, not even the marker, has a right to interfere with the play, or point out an error which either has been or is about to be committed. The player to whose prejudice the foul stroke is made, must find that out for himself.

2d. Even after a stroke has been made, no one in the room has any right to comment on it, either for praise or blame; for the same stroke may occur again in the course of the game, and the player's play be

materially altered by the criticism to which he has just been listening.

3d. Let marker and spectators keep their places as much as possible, for if they crowd or move around the table, they are *liable* to interfere with the players, and certain to distract their attention.

4th. When the spectators are appealed to by the marker, for their opinion on a point which he has been asked, but finds himself unable to decide, such of them as are well acquainted with the game should answer according to the best of their knowledge and belief. Those who know little or nothing of the game would oblige themselves and others by at once confessing their incompetency. Either they may not have seen the disputed stroke, or seeing it, they may not have been familiar with its merits.

RULE XI.

ON THE MARKER'S DUTIES IN PARTICULAR.

The marker's duties may be thus summed up:

1st. To proclaim each count in a voice that can be heard by the player at his own table.

2d. To post the total run made by each player before the next begins to strike.

- 3d. To spot the balls when necessary.
- 4th. To furnish the bridge and other implements of the game, when called for.
- 5th. To see that the player be not obstructed in his stroke by being crowded by the spectators.
- 6th. To decide without fear or favor all questions of order and fairness which shall be officially laid before him for his opinion. But,
- 7th. Let him never volunteer a remark upon any portion of the game.
- 8th. Let him never touch a ball himself, nor allow any other person except the players to touch one, except when officially called upon to replace the balls, as specified in Rule VII., or when asked to decide as to which is the ball that properly belongs to the player. In this case, should the spot be turned down on the table, he may lift the ball to ascertain the fact—but never let him touch them voluntarily.
- 9th. Finally, when called upon to decide a disputed point, of which he has no personal knowledge—the fairness of a shot which was made when he was looking elsewhere, for instance—let him proclaim silence, and take the opinion of such of the company as avow themselves competent to judge. The voice of the majority should be allowed to settle all debate; but should their decision be flagrantly in conflict with any

of the well-known and admitted rules hereinbefore laid down, the party who fancies himself aggrieved may give notice of appeal to lay the question before what the lawyers would call "a jury of experts"—the marker, meanwhile, or some other responsible party, holding the bets, if any, which depend on the decision. This appeal is final; and must be made before another stroke is played.

FURTHER RULES FOR THE FOREGOING GAME,

WHEN PLAYED AS A FOUR-HANDED MATCH.

In a four-handed match—two playing in partnership against two—the foregoing rules of the single game must be substantially observed, with the following additions :

1st. Each winning hazard made by the player puts the opponent who preceded him out of play. Consequently, the partner of the party so put out, steps in and takes his place.

2d. But if the player makes a losing hazard (pockets his own ball), or makes two misses in succession, or causes his ball to jump off the table, or lodge on the cushion, he loses his hand, and must resign it to his partner.

3d. In this double match the player's partner is at

liberty to warn him against playing with the wrong ball, or playing, when his ball is in hand, at an object-ball within the string; but he must *not* give him any advice as to the most advantageous mode of play, &c., &c., except it has been otherwise agreed before the opening of the game.

FURTHER RULES FOR THE SAME GAME, WHEN
PLAYED BY THREE INDEPENDENT PLAYERS.

RULE XII.

The rules of the single American game are substantially binding on the three-handed game, with the following additions, to meet the increase of players:

1st. The players commence by stringing for the lead, and he who brings his ball nearest to the cushion (as in the single game) wins the choice of lead, balls and play; and he who brings his ball next nearest to the cushion has the next choice of play. The third player cannot enter into the game until the first hazard is made, or until one of the players pockets his own ball, or makes two misses in succession, or causes his own ball to jump off the table or lodge on the cushion.

2d. All forfeitures in this game count for *both* of the opponents, at the same rate as in the single-handed game.

3d. If a player makes two misses in succession, or pockets his own ball, or causes his ball to jump from the table, his hand is out.

4th. He who can first make sixty-six points is out; the other two continue until one reaches the hundred.

5th. When he who has first made sixty-six retires from the game, the player whose hand is out adopts his ball, as that ball is entitled to its run, and also to the next play.

6th. If the player should cause both his opponents to become sixty-six by a forfeiture, neither of the parties can claim game thereon, but must win it by their next count. But if only one of the opponents be in a position to become sixty-six by a forfeiture, then the forfeiture reckons as usual, and that opponent wins the game when such forfeiture is made.

So much for the American, or four-ball game.

FIFTEEN BALL POOL.

This is an excellent game for the novice—full of pleasant excitement, and offering better opportunities for hazard practice than almost any other on the board.

As its name imports, there must be fifteen object balls employed in playing it—balls made expressly the game, and numbered from 1 to 15. These

balls are placed in the form of a triangle upon the table—a wooden frame being employed to save trouble and insure correctness. The deep red ball, inscribed with the highest number, occupies its usual place upon the board, and forms the apex of the triangle, pointing upwards towards the string. Each player is to pocket as many balls as he can, the number on each ball pocketed being scored to his credit; so that not he who pockets the largest number of balls, but he whose hazards when added up yield the largest total, will win the game. Thus, A. might pocket all the balls numbered from 1 to 7, and his total would be but 28; while B., with a better eye to the main chance, would walk away from him by pocketing the two balls marked 14 and 15, giving a total of 29.

There is only one cue-ball (the white) used, each player playing with it as he finds it on the table, or from behind the string, if it be in hand. The following are the rules:

1st. The order of playing may be settled as for two-ball pool. The player plays from behind the string, as in the ordinary game, and may miss if he likes—but the miss, and all misses at this game, will score *three* against him. The other players follow him in their order of rotation.

2d. The player, if it pleases him, may use either the butt of the cue or the mace; and jam his own ball against the others, not being obliged to withdraw the

mace or cue before the cue-ball comes in contact with the object-ball.

3d. As the sum total of the figures on the 15 balls amounts only to 120, of which 61 is more than half, whoever makes the latter number first is winner, and may claim the stakes.

4th. Three points are deducted from a player's score, for making a miss or a losing hazard, or forcing his own ball off the table.

5th. If the player pockets one or more of the object-balls and his own ball at the same time, he cannot score for the numbered balls, which must be placed on the spot, or in a line behind it, if the spot be occupied, and he forfeits three for his losing hazard.

6th. A hazard is good in this game, even when the cue and object-balls are in contact.

7th. As in the ordinary game, the player, when the cue-ball is in hand, may play from any place within the string at any object-ball outside it.

8th. And should none of the object-balls be outside, he may spot that which is nearest out of the string on the deep red spot, and play accordingly.

9th. Should there be a tie between two or more of highest players, its decision may be referred to the

succeeding game ; and whoever counts highest in that, shall be declared the victor of the former one, totally independent of the game that is then on hand. A man might thus win an undecided game of fifteen-ball pool by scoring one in the succeeding game, provided neither of his adversaries scored anything at all.

10th. Should they again be tied in the second game, it may be referred to a third.

11th. This game is sometimes played for small stakes, but more frequently the only issue to be decided is—who shall pay for the use of the table? This charge must be met by the player who has the lowest count, and it is quite possible in this game for a player's count (owing to forfeitures of various kinds) to be half a dozen or a dozen worse than nothing. Thus, if A. had neither won nor forfeited anything, while B. had pocketed balls 5 and 3, but had also made three forfeitures—B. would have to pay, as his forfeitures amounting to 9 and his assets only to 8, would leave him worse off by one than A., who stood at simple zero, while B. was zero minus one.

RULES FOR THE DOUBLET, OR FRENCH GAME.

This game is played with one red ball and two white—one for each of the players.

The red ball is spotted on the deep red spot, and the white balls must be played from within what is called the string. This string differs from ours, inas-

much as it is not a line drawn across the table from any place behind which a player may play. The string is a semi-circle drawn with a radius of four and a half inches, having the spot on the ordinary string line for its centre, and the string line itself for its base. From within this semi-circle the balls must be played on the opening of the game, or when they are in hand; and while so playing, the striker is confined to the end cushion at which he stands, not being allowed to pass outside or in advance of either corner pocket.

To make a count the player must make the object-ball strike a cushion, and cross the board before falling into the pocket—this is called a doublet or cross; or force one ball to kiss the other into the pocket; or make a carom, or receive the count as a forfeiture from his opponent.

The game commences by stringing for the lead as in the ordinary American game, and he who brings his ball back nearest to the head cushion at which he stands, is the winner, and can play first or make his adversary do so, at discretion. For making a miss he forfeits *one*. For pocketing his own ball after it has hit the white,—or for causing his own ball to jump off the table or lodge on the cushion after it has hit the white, he forfeits *two*, and this irrespective of whether it may, or may not have touched a red ball.

If he pockets his own ball after it has touched the red ball only, or causes it to jump off the table, or lodge on the cushion after it has touched the red only, or pockets it without having touched any ball at all, he forfeits *three*.

If he holes the red ball direct, without crossing or kissing it in, he forfeits *three*; and for pocketing the white in the same way, loses *two*.

For pocketing the red ball, either by a cross or kiss, he gains *three*.

For holing his opponent's ball in the same way, he gains *two*.

For an ordinary carom he gains *two*.

For a carom off the red on the white, and pocketing the white, he gains *four*.

For a carom off the white on the red, the red being pocketed, he gains *five*. [It, of course, must be understood in all these cases, that the ball pocketed has been previously crossed, kissed, or caromed in; for if it was holed directly, without the doublet, kiss, or carom, he would lose in an inverse ratio to the gains here set down. Thus, if he caromed on the white and red, and pocketed the red *directly*, he would lose five. For pocketing both under similar circumstances, seven; and should he pocket his own ball along with the two others, he would lose nine, under any circumstances.]

No pushing, or what we call "foul shots," are allowed in this game. The player must withdraw his cue or mace from his own ball, before it comes in contact with the object-ball, otherwise he forfeits the stroke, and can count no points he may have made by it.

RULES FOR THE THREE-BALL, OR FRENCH CAROM GAME.

This game is generally played on a table without pockets, made especially for the carom game; it is here more frequently, however, played upon the common table.

The players string for the lead as in the preceding game, but the winner is entitled to have his opponent's ball spotted within the semicircular string.

Hazards do not count in this game. No pushing strokes are allowed.

Each carom, fairly made, counts one for the player.

When the game is played on a common table, each time the red is pocketed, it must be replaced on the deep red spot: and each time the player holes his adversary's ball, at the same time making a carom, the ball pocketed must be spotted on the spot within the semicircular string.

Should the player pocket his own ball after making a carom, he is entitled to his count, and the next play, as if no such accident had occurred; the only penalty is, that he must play from within the semicircle, at a ball outside the string. But should more of the balls be outside, in this case he may call upon the marker to spot the red on the deep red spot, and play at it.

Each time a ball is forced off the table, it must be or played as above; but should both spots be the ball must be placed on the centre of the

table. If no carom was made by it before jumping off, it must be spotted; if a carom was made by it, it must be played from within the semi-circle, as is laid down in the preceding paragraph.

The following additional rules for this game were adopted in a match which the writer recently played. Their substance was as follows, but the wording has been slightly varied for the sake of greater clearness to the general reader.

1st. The parties shall string for lead, the winner being entitled to have his opponent's ball spotted, on the spot within the semi-circles, or to spot his own ball as he may choose.

2d. Whenever at the commencement, or in consequence of having being pocketed or jumped off, the player's ball shall have been spotted within the semi-circle, it shall be considered as if in hand (having been only put there to give the adversary a chance of caroming,) and may be played from any point within the semi-circle.

3d. When the player's ball is in hand, he must keep his body in playing, within line of the two end pockets at the head of the table.

4th. If, when the playing ball is in hand, the two other balls should be within the string, the player can have the red ball spotted on the deep red spot.

5th. Should the player's ball be held, not **having**

counted, and the other white ball be on its spot, not having rolled there, it must be taken off, and the white ball held, be placed on the spot.

6th. If the upper spot be occupied either by the red ball, or by a white ball having rolled there, and the other be held, it must go on the centre spot.

7th. The red ball having been held and its spot being occupied it must go the centre spot—should two of the spots be occupied, it must go on the third.

8th. All shots shall be fair, no pushing being allowed.

9th. If the player touches in any manner, any of the balls, it shall be considered a shot, and any second touch shall be considered foul. Should the player touch his or any other ball before making his stroke, his opponent may have the balls replaced—but should the player touch a ball after his stroke has been made, his adversary may have only the ball so touched, placed where it ought to have rested had it not been touched.

10th. If the player's ball touch another he cannot count, but he may play his ball. Should he touch the other ball with his, the balls must be spotted, and his opponent play in hand.

11th. Each carom fairly made shall count one. No penalty shall attach to a miss, nor to the pocketing of player's ball.

12th. No mace shall be permitted in the game, but each player shall have the privilege of using the bridge.

In this game the writer made some interesting shots, a few of which are illustrated in the following diagrams.

DIAGRAM NO. XXVI.

DIRECTIONS FOR PLAYING NO. 26.

Strike the cue-ball $\frac{1}{4}$ above the centre, $\frac{1}{2}$ left; the object-ball to be hit $\frac{1}{2}$ right. Play hard enough to make the object-ball return, as far back from the lower cushion as its original position.

There are several modes of effecting a carom on the balls as represented in diagram No. 26, for instance, by forcing back direct on the ball, or with a strong twist the reverse of the one indicated on diagram, causing the cue-ball to take the upper cushion, or by playing on the left of the object-ball, and taking two cushions—but in this, above all other games played on the billiard table, the greatest foresight and calculation are necessary, as it is not only a game of attack, but also of defence. By playing in the manner represented on diagram, if a count was not made, the balls would be “safe,” as the cue-ball would have gone below the opponent’s ball, and the object-ball would have rolled back again above it, thus leaving the opponent’s ball between the two, which is the strong defensive part of the game.

No. 26.

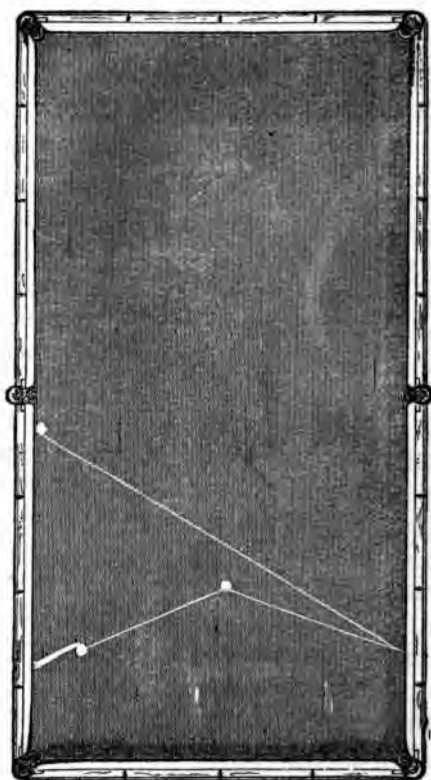

THE NEW YORK
PUBLIC LIBRARY.
ASTOR LENOX AND
TILDEN FOUNDATIONS.

THE NEW YORK
PUBLIC LIBRARY.
ASTOR, LENOX AND
TILDEN FOUNDATIONS.

No. 27.

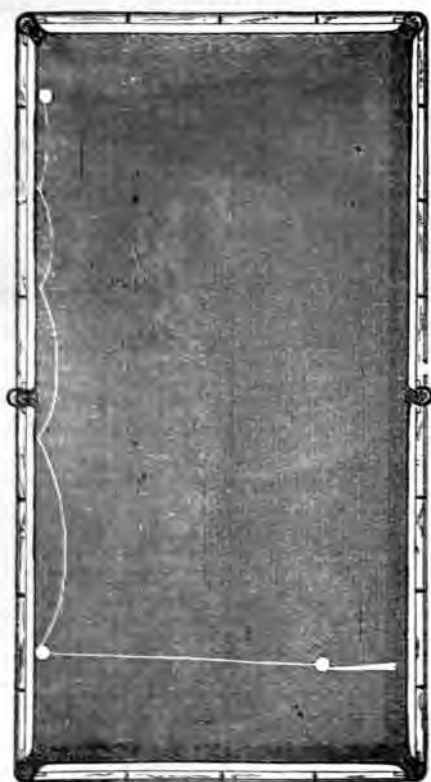

DIAGRAM NO. XXVII.

HOW TO PLAY NO. 27.

Strike the cue-ball $\frac{1}{4}$ above, $\frac{1}{4}$ left, play hard—the object-ball to be hit $\frac{1}{4}$ right, as indicated in diagram.

This shot was made by Mr. Phelan in the fifth game.

DIAGRAM NO. XXVIII.

HOW TO PLAY NO. 28.

Strike the cue-ball $\frac{1}{2}$ left of centre, play hard—the object-ball to be hit $\frac{1}{2}$ right, as indicated in diagram.

This is rather a risky shot to play, as if it missed, the chances were that a fair prospect of a count would have been left to the opponent—but as a general rule it is best to play for such shots, especially if the player be ahead, as was the case in this instance.

No. 28.

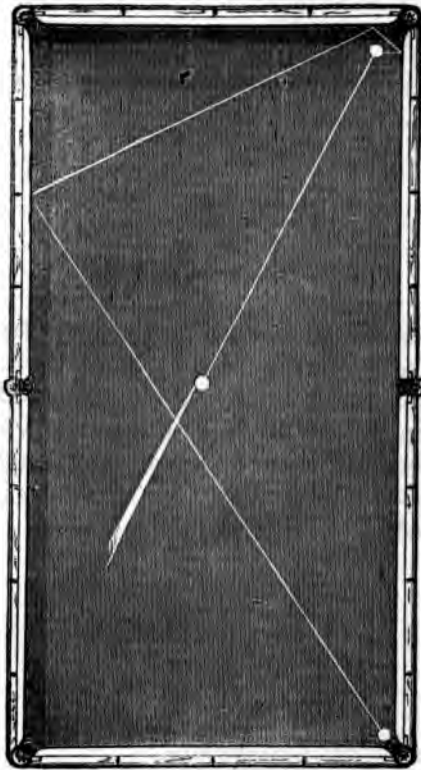

THE NEW YORK
PUBLIC LIBRARY.

ASTOR LENOX AND
TILDEN FOUNDATIONS.

RULES FOR THE RUSSIAN GAME.

This is a very agreeable variety of the game, and ought to be more popular in this country than it is.

Five balls are required to play it; two white ones for the players, and a red, a blue, and a yellow ball for the board. The blue must be placed on the light red spot, the yellow on the spot between the pockets, and the red on the deep red spot.

In this country it is most usually played one hundred points up; although in Germany and Russia the game is forty.

The peculiarity of the Russian game is, that certain balls are confined to certain pockets, and that a different count is attached to each color, both in the hazards and the caroms made off it, and the forfeitures lost from it. The following are the rules:

1st. The player may pocket his opponent's ball in any pocket, and will count *two*.

2d. The same rule applies to the red, and counts *three*.

3d. The same also to the blue, and counts *four*.

4th. But the yellow, or Caroline ball, as it is termed, when holed in either of the side pockets, counts six for

the player,—but if pocketed in any of the corner pockets, the player forfeits six.

5th. If the striker pocket his own ball without hitting any of the balls upon the table, he forfeits three—after hitting the white, two; after hitting the red, three; after hitting the blue, four; and after touching the yellow or Caroline, six.

6th. Thus, again, in caroms: A carom on the white and red scores two; on the red and blue, or blue and red, three; a carom off or on the white and yellow, three; and a carom on or off a yellow with a red or blue, counts four.

7th. The same penalties attach to the player who has caused his ball to jump off or lodge on the cushion as if he had pocketed his own ball.

8th. The striker, when leading off, or having his ball in hand, may play from any point within the string, at any ball outside of it.

9th. In addition to the penalties specified in Rule 5, for a losing hazard, the player also loses whatever points he may have otherwise made by the stroke.

10th. After the striker has pocketed any of the object-balls, he can play next at any ball on the table.

11th. But after a carom stroke, where no ball has been holed, he must play next on the yellow, no matter what be its position.

12th. To continue play there must be a hazard after every carom ; otherwise the second carom counts for the player, but he loses his hand.

13th. Carom points will not count to win the game. The winning stroke must be a hazard.

14th. For every ball he touches in giving the lead, the player loses one point ; and should his ball occupy the spot of any of the three balls he may have displaced, he must take it up and lead over again. He cannot score any points made on the leading stroke

RULES FOR THE SPANISH GAME.

This game is seldom seen in the Northern States, but is very common in some parts of the South, as also in Mexico and California.

It introduces a new element into the game of billiards, in the shape of five wooden pins ; diminutive little things, which are set up in a diamond pattern between the two side pockets, each pin being about two and a half inches from the other, as in pin pool.

Nine pins are sometimes used instead of five, but the manner of playing remains the same.

The game is generally played thirty-one up, and is scored by hazards, caroms and knocking down the pins. The rules are extremely simple :

1st. For every pin the player knocks down after first striking a ball with his own ball, he gains two points.

2d. If he knock down the middle pin alone, he gains five.

3d. For pocketing his opponent's ball the player gains two, and two for each pin he may have knocked down by the same stroke.

4th. If he pocket the red ball he gets three, and two for each pin, &c.

5th. If the player pocket his own ball, cause it to jump over the side, or lodge on the cushion, without having touched any of the other balls, he loses three.

6th. But if he does any of the aforementioned things after having touched any of the balls, he loses in addition to the three, whatever points he would otherwise have made by his play, at the regular rate of counting.

In other respects—as regards foul strokes, and so forth—the rules of the ordinary American game may all be applied to the Spanish, with such additions as are hereinbefore set down.

RULES FOR THE ENGLISH GAME.

This game is the only one much played in this country, in which the player pocketing his own ball—or making a losing hazard, as it is termed—is allowed to count for it. For this reason it is sometimes called the “Winning and losing Carambole game,” to sig-

nify the three kinds of strokes for which the player is permitted to score.

In stringing for the lead, the same semicircular baulk is used at the string line, which we have already described, in giving the rules of the French doublet game. In England the red ball is spotted thirteen inches from the lower cushion; but is here generally placed at nine. The string is a semicircle at the head of the table, drawn with a radius of ten inches, from which the cue-ball is always played when in hand. Otherwise, the game is commenced as with us. The following are the distinctive rules of the English game—in other respects, where it is not specified to the contrary, the rules of the American four-ball game are binding :

1st. Where odds are given in the game, the player receiving them must break the balls either by striking the red, or giving a miss, for which he forfeits one.

2d. If he chooses to miss, the stroke must be played with the point, not the butt, of his cue.

3d. The game, as played in England at present, is commonly fifty up; but in this country sixty-three is the more usual rule.

4th. If a player forces the object-ball off the table, he cannot score any counts he may have otherwise made by the shot.

5th. Forcing your own ball off the table after it has struck another, involves no forfeiture.

6th. But if your own ball jumps off without having touched either of the object-balls, it is called a "coup," and you lose three points.

7th. In the score of the game, a hazard made either with your opponent's ball, or by pocketing your own, counts *two*.

8th. Either to pocket the red or to pocket your own off the red, counts *three*.

9th. For pocketing your own and adversary's ball, *four*.

10th. For a carom and hazard, made with either of the whites, *four*.

11th. For holeing a red ball and either of the whites, *five*.

12th. For a carom and a hazard, either made with or off the red ball, *five*.

13th. For pocketing your own and the red ball, *six*.

14th. For making a carom where the white ball is first struck, and for pocketing your own and opponent's balls, *six*.

15th. For pocketing the two whites, and making a carom off the red, *seven*.

16th. For pocketing all the balls, where the white is first struck, *seven*.

17th. For doing the same, where the red is first struck, *eight*.

18th. For pocketing your own, the red, and making a carom, *eight*.

19th. For pocketing all the balls and caroming where the white is first struck, *nine*.

20th. For the same where the red is first struck, *ten*, which is the highest that can be made by any single shot in this game.

21st. The player may continue to play so long as he makes a count each stroke, except when his hand is forfeited for a foul shot.

22d. It is entirely at the option of the opponent whether he will enforce the penalty for a foul stroke, or play with the balls as they are left. But if he neglects or is disinclined to claim the forfeiture, the player may count all the points made by the foul stroke, and continue his game as if no error had occurred.

23d. When the white ball stands on the deep red spot, while the red ball has been either pocketed or forced off the table, the red must be placed on the string-line spot. Should this also be occupied, the red must then be placed on the spot between the side-pockets.

24th. For a miss, the player loses *one* to his adversary. For a miss when he pockets his own ball as well, or causes it to jump off or lodge on the cushion, *three*.

25th. Where a carom or hazard is made by a striker playing with the wrong ball, the player cannot count, and his opponent may have the balls broken; but if nothing be made, then the opponent may play with whichever ball he likes, but must continue to play therewith to the end of the game.

[NOTE.—To have “the balls broken,” is a technical phrase, which means to have them replaced as they stood at the opening of the game.]

26th. When the two object-balls are within the string and the player's ball in hand, he cannot play at them except from a cushion outside of baulk.

27th. A player whose ball is in hand cannot play at a cushion *within the string* in order to strike a ball that is outside of it. Under such circumstances, he must send his ball outside of baulk before it touches anything, or can be acknowledged as in play.

28th. If a player chooses to give a miss within the baulk line, it is at the option of his adversary to compel him to play outside.

29th. If a player, after making a hazard or carom, takes up his own ball or any other ball, under the idea that the game is over, his opponent can either demand that the balls shall be broken, or have them replaced exactly where they were.

30th. If, after a miss or coup, the player take up any of the balls, under the idea that the game is over, he loses the game.

31st. When a player has made a foul stroke, it is always at the option of his opponent to have the balls broken, or replaced by the marker.

In cases not specifically provided for by any of the foregoing rules, let it be understood that the rules of the ordinary American game are binding.

RULES FOR THE GAME OF TWO-BALL POOL.

This game is not much in use at present, though about a dozen years ago it was universally in vogue. It is opened in the following way, and any number of players from 2 to 20 may be engaged in it at once.

A number of little balls (as many balls as there are players) are dropped into a pocket, from which, after having been shaken, they are drawn at random by the marker and presented to the different players. These little balls are numbered one, two, three, &c., up to the number of players; and the number engraved on the ball which the marker hands to the player decides his position in the game, and the order of rotation.

This game, as its name implies, is generally played for a small pool, into which each player contributes the price of his ball. At present these stakes are generally limited to an amount which, in the aggregate, will suffice to pay for the use of the tables; but the disuse into which the game has generally fallen arises, in all probability, from the dislike which the modern school of billiard-players feel, to the principle of a bet, however small.

When a professional player plays against a professional player, a bet is sometimes made, as a matter of necessity, to pay each player for his time; but such bets are of a purely business character, and can in no wise be associated with gambling. It is a very rare thing indeed in these days, and growing rarer every day, to see an amateur stake money on his skill; the only money question depending on the game in ninety-nine cases out of every hundred, is—Who shall pay for the table? Sometimes they add to this a couple of cigars, or refreshments; but the practice of betting money is growing obsolete, and hence the decline of the billiard sharps, who have had to seek “green fields and pastures new” for the exercise of their disreputable ingenuity.

There are only two balls used in this game—a red and a white; consequently there can be no caroms. The players are called Numbers One, Two, Three, &c., according to the figures on the balls drawn from the pocket, and the player must always make his cue-ball of the ball which was object-ball in the preceding stroke, except when a ball has been pocketed. In this case there must be a new lead—the next player leading with the red ball, and being followed with the white ball from the string. Subjoined we give the specific rules for two-ball pool:

1st. Player Number One must lead with the red, but has the privilege of spotting his ball, in case the lead does not please him. But if, in a pushing lead, he does not withdraw his mace or cue from the ball before

it passes the middle pockets, the stroke is foul, and player Number Two has the option of playing at the ball as it is left, having the lead played over again, or causing the red to be spotted on the pool spot.

2d. Each player has one, two or more lives, as may be agreed on. When he forfeits these he is said to be dead, except when he obtains what is called a "privilege," meaning one chance more.

3d. This privilege, except where all the players consent to its remaining open, must be taken by the first man "killed;" and the person so killed must determine whether he will accept it or not at once, before another stroke is played. [This is the strict rule of the game, and as such may be enforced; but as a general practice, the privilege remains open until taken up by some one of the players.]

4th. After a game has been commenced, no one can take a ball, except with the consent of all who are already in the game; and after the privilege is gone, no stranger can be admitted to the game under any circumstances.

5th. Any person in the pool whose lives are not exhausted, and who thinks a hazard may be made in a certain position, can claim the stroke, or "take the hazard," as it is technically called, in case the striker does not choose to risk that particular stroke himself. Should the person who takes the hazard fail to execute it, he loses a life.

6th. The player has the best right to take a hazard, and must be marked if he fails to pocket the ball, in case any other player in the pool has offered to take it.

7th. In playing out of his turn, the player loses a life, unless he pockets the object-ball, in which case the ball pocketed loses a life, and the next in rotation to the person who ought to have played, plays.

8th. But if one player misdirect another by calling on him to play, when it is not his turn, the misdirector, and not the misdirected, loses a life, and the next in turn must lead with the red as usual.

9th. Whoever touches any of the balls while running, forfeits a life. This rule is invariable, and can only be relaxed by the consent of all the players.

10th. No player can own or have an interest in more than one ball at a time; nor can he buy another ball, nor own an interest in another ball, while his own ball is either alive or privileged.

11th. After the number which he drew is dead, he may buy that of another player, and take his place; but if the seller only dispose of an interest in his ball, he must either continue to play it himself or sell out his ball *in toto*, in which latter case any member of the original pool may buy and finish out the game.

12th. But no person not included in the original pool can be permitted to buy in and play; though out-

siders may purchase an interest in a ball, still permitting the original member of the pool to play it.

18th. If the leader sells his number upon the lead, the purchaser must either allow the lead made to stand, or the ball may be spotted at his option.

14th. A lead once made cannot be changed, even when the next player sells his ball to a third party; but the leader has, at all times, the option of having his ball spotted.

15th. No player can strike twice in succession, under any circumstances, except when there are only two players left, and one of them has holed his opponent's ball. In that case, the person who has pocketed the ball must lead for his adversary to play on.

16th. When only two players are left, and either of them wishes to divide or sell, his opponent shall have the first right of buying, provided that he offers as much as is offered by any of the others who are entitled (by having been in the original pool) to purchase. But should he not offer as much, then the ball may be sold to the highest duly-qualified bidder.

17th. If a player, playing on the lead, places his ball outside of the string, and has his attention called to the fact by the leader before the time of striking his ball, it is optional with the leader either to compel him to play the stroke over again or let the balls remain as they are.

18th. If it be found that the marker has not thrown out balls enough for the number of players at the commencement of the game, his mistake will not alter the conditions of any bets which may have been made amongst those to whom balls were actually distributed; these stand irrespective of his error. The balls must be again shaken up, and thrown over, and then the game commences.

With the foregoing exceptions, the rules of the ordinary American game as to striking with both feet off the floor, interrupting your adversary when in the act of striking, &c., &c., may be applied to two-ball pool.

RULES FOR THE GAME OF PIN POOL

AS PLAYED IN NEW YORK.

This game is a very amusing one, and seems to have been made up out of the odds and ends of half a dozen others: it has pins in it like the Spanish game, small numbered balls, like two-ball pool, and reminds us of Vingt-un at cards, by the player's liability to "burst" if he exceeds a certain number. Pin pool might indeed be called Trente-un, as thirty-one is the winning number. The following rules are for the game, as played in New York and its vicinity, and may be adapted in the important matter of counts, forfeitures, &c., to the game as played in all other parts of the Union. In Philadelphia, and other places, four balls are used in playing it. We shall therefore lay down rules for the regular game as played here; for to enter

into all the varieties would be an endless task ; and when once the general rules are understood, the different variations may be readily brought within its operation.

The game of pin pool, then, is played with two white balls and one red, together with five small wooden pins, which are set up in the middle of the table, diamond-fashion, as in the Spanish game. But in the latter game, each pin had the value of two points ; while in this, each pin has a value to accord with the position it occupies.

4*

3* 5* 3*

1*

The pin nearest the string line is called No. 1 ; the pin to the right of it, No. 2 ; to the left, No. 3 ; the pin farthest from the string line, No. 4 ; and the central pin is No. 5 ; these numbers are generally chalked on the table in front of each particular pin.

Neither caroms nor hazards count ; for pocketing your own ball, or causing it to jump off the table, or lodge on the cushion, or for missing altogether, you lose nothing. The only penalty is, that the ball so offending shall be spotted about five inches from the lower cushion, midway between the corner pockets.

When the pins are arranged, the rotation of the players is determined in like manner as in two-ball pool. After which, each player receives from the marker a little number-ball, which is termed his private ball, the number of which is not known to any of his opponents.

The object of the players is to knock down as many pins as will count thirty-one, when the number on the private ball is added to their aggregate: thus, if a player's private ball be No. 9, he will have to gain twenty-two points on the pins before calling "Trente-un," and whoever first gets thirty-one points in this manner, wins the pool.

When the rotation of the players is decided, the red ball is spotted about five inches from the bottom of the table, and midway between the pockets, on a line drawn down the centre. The game is then commenced.

Rule 1st. Player No. 1 must play with either of the white balls at the red, or place his own ball on the deep-red spot.

2d. Player No. 2 must play at either ball, or spot his own ball on the light-red spot.

3d. Players No. 1 and No. 2 may play from any part within the string. No. 2 can play on any ball outside the string, and should none be so situated, he may have the red ball placed on its appropriate spot.

4th. After the second stroke has been played, the players in their order may play with or at any ball upon the board.

5th. Unless the player has touched some ball upon the board before knocking down a pin, the stroke, under all circumstances, goes for nothing, and the pin or pins must be replaced. But should two balls be in contact, the player can play with either of the balls so

touching, direct at the pins, and any count so made is good.

6th. If a player, with one stroke, knocks down the four outside pins and leaves the central one untouched, under any and all circumstances he wins the game.

7th. But if the player has knocked down pins, whose aggregate number, when added to the number on his private ball, exceeds a total of thirty one, he is then "burst," and must then drop out of the game, unless he claims the "privilege." If he wishes to claim this, he must do so before another stroke is made, as otherwise he can only reënter the game by the consent of all the players.

8th. Players having bursted, can claim "privilege" as often as they burst; and when privilege is granted, the player draws a new private ball from the marker, and has then the option either of keeping that which he originally drew, or adopting the new one then drawn: but one or other he must return, or else he cannot, under *any* circumstances, be entitled to the pool.

9th. Every privilege taken succeeds the last number of the players in the order of its play. Thus, if there are ten players, and No. 2 bursts, he appears again under privilege, as No. 11, and follows No. 10; and all the players that are burst after him, will have to follow No. 11, in the order of their reëntry into play. So that if it be the highest number in the pool that bursts, he will follow on immediately after choosing his private ball.

10th. If a player make a miss, or pocket his own ball, or cause it to jump off the table or lodge on the cushion; or if, after jumping off it should be thrown back upon the table by any of the bystanders—under any of these circumstances, the ball must be placed on the spot five inches from the bottom cushion on the central line—or should that be occupied, then on the deep-red spot—or should that also be occupied, then upon the light-red spot.

11th. Should the spot appropriated to any of the pins which have been knocked down, be occupied by any of the balls, said pin must remain off until said spot is again uncovered.

12th. If a player has made thirty-one, he must proclaim it before the next stroke is made—for which purpose a reasonable delay must be made between each play, more especially in the latter portion of the game. But if a player has made thirty-one, and fails to announce it before next play (a reasonable time having passed), then he cannot proclaim the fact until the rotation of play again comes round to him. In the meanwhile, if any other player makes the number and proclaims it properly, he is entitled to the pool, wholly irrespective of the fact that the number was made, though not proclaimed before.

13th. Merely touching a pin or shaking it, goes for nothing, and the pin must be replaced on its spot. To count a pin, it must be either knocked down or removed full inches from the spot on which it stood, in

which case it shall be counted, even though it maintains the perpendicular.

14th. A player cannot use any count he may have made by playing out of his turn : but if he has made pins enough to burst him by such stroke, the loss is established, unless in cases where he was called on to play by some other of the players, who either believed or pretended it was his turn. In such case he cannot be burst by his stroke, and he whose turn it was to play, plays next in order.

15th. Pins which have been knocked down by a ball whose course has in anywise been illegitimately interfered with, do not count; nor can pins knocked down by any other ball set in motion by the same play, be reckoned.

16th. If a ball jump off the table and be thrown back by any of the bystanders in such a way as to knock down pins, such pins do not count, and the ball must be spotted as aforementioned, and the pins replaced. But if any other ball set in motion by the same stroke gets pins, the pins so made by the other ball must be reckoned.

17th. If the marker finds that there are any of the private balls missing, it is then his duty to announce the number of the missing ball; as in no case can a player having that ball, or more than one private ball in his possession, win the pool. His other duties consist of keeping and calling the game at each stroke,

and seeing that the pins and balls be spotted when and as required.

18th. A player taking a privilege is entitled to a strike, to secure his stake to the pool.

RULES OBSERVED IN PLAYING PIN POOL,

AT MICHAEL'S BILLIARD ROOMS, SAN FRANCISCO.

IN San Francisco, from the mixed character of its population, a new set of rules became absolutely necessary, to reduce into something like settled order the innovations which players from different nations made in the established usages of the game. The following rules were drawn up by the author, while residing in San Francisco, and are still the regular law of the game as it is there played:

1st. Two balls must be placed upon the spots at the foot of the table.

2d. The person drawing the No. 1 ball must play from the string at the head of the table.

3d. When a player makes a miss, or hits a pin before hitting a ball, the ball played with shall be spotted at the foot of the table. In case of there being a ball upon the spot at the foot of the table, the ball shall be spotted upon the spot nearest the same.

4th. Should a player make more than *thirty-one*, he shall declare himself *burst*, before another stroke be made, for the safety of the rest of the players.

5th. If a player make a stroke and make pins, and wish to plant, he must, on so making pins, declare that he plants, before another stroke is made.

6th. If any other player should wish to plant, he can do so, on making pins.

7th. And if those who plant have the same number, counting their ball and the board, the player planting first shall still be good, and the last planter shall be bursted; but if the last planter is nearer thirty-one than the first, the first planter shall be bursted.

8th. If a player in the game should burst, he can purchase any ball still in the game, by consent of the player owning such ball.

9th. No player can play the planter's ball but himself.

10th. When a player is absent, and his number is called three times, the gamekeeper shall play the ball, at the risk of the player owning such ball.

11th. Any number scored wrong upon the board, shall be corrected before the player, whose score is wrong, shall have played. If he neglect to correct such mistake before he plays, it shall stand as scored upon the board.

12th. No player can purchase a ball until his own be dead.

13th. No player can purchase a ball after having seen more than one, without the consent of the rest of the players.

14th. If a player, at one stroke, should knock down the four outside pins, and leave the centre pin standing, it shall be counted as thirty-one, and the player making the stroke, wins the pool.

15th. If the planter should make the four outside pins, as in Rule 14, or should make thirty-one for the player planted upon, it is pool for the player planted upon.

16th. The planter plants upon the preceding player.

17th. The player preceding the planter, shall be entitled to a stroke before the planter's play counts on him.

18th. After a stroke is made, sufficient time must be allowed the player to add up his game, and to proclaim pool, if he makes it, or to plant, if he wishes to, before the next play. If he neglect to claim the pool before the next play, he must wait until his turn to play comes again, when he may declare pool, but if another makes pool in the meantime, that other is entitled to it, and not he who first made it.

19th. Should a ball stop on any of the spots intended for the pins, such pins are to remain off the table until those spots so occupied become vacant. Provided, such pin or pins be down.

20th. Should a ball roll against a pin, and cause it to lean over, or move it off the spot, without knocking it down, the player cannot claim such pin, as nothing but knocking the pins down. But when the

pins are moved two inches from the spots, they are considered down, whether down or standing.

21st. Should a player play out of his turn, he cannot count the pins made by such stroke, but if he make pins enough to burst him, it is his own loss—provided he was not called on to play; in such case he cannot lose by it, and any count made by such stroke is null. He whose turn it was to play, when the other played out of turn, plays next in order.

22d. But one privilege is allowed in the game, (the first player bursted,) unless by consent of all the players.

23d. In taking a privilege, the player has the right to draw a second private ball, and to choose between that and his original ball; but he must decide quickly which ball he will keep, before the next stroke be made.

24th. Each privilege follows the last number, in rotation, the first privilege playing immediately after the last player in the original game, the second privilege follows the first, and so on. If the last player burst and take a privilege, he plays on, immediately after choosing his private ball.

25th. If the balls are touching each other, the player can play with either of the balls so touching, straight at the pins, without touching another ball, and any count so made is good except when the play conflicts with Rules 26, 27 and 31.

26th. Any pin knocked down by jarring the table, blowing upon the ball, or altering or intercepting its course in running, does not count, nor is the player entitled to any pin or pins that may be made by any ball (though not interfered with), during the same play.

27th. Should a ball jump off the table, and come in contact with a player, or any other person, and fall back on the table and knock down pins, such pin or pins so knocked down shall not count, and the ball must be spotted; but if another ball gets pins by the same stroke, the pins so made are counted.

28th. Should a player, in the act of striking his ball or playing, knock down pins otherwise than with the ball played with or at, he is not entitled to such pins, or any others he may make by the same stroke.

29th. Should a player, in the act of playing, touch the ball with his cue before the stroke is made, it shall be declared a miss, and the ball be spotted.

30th. The gamekeeper is not responsible to the winner of a pool for more than the actual amount of stakes received from the players in such pool.

31st. The player is not entitled to any pins knocked down unless his private ball be placed in its proper place in the board.

d. The players themselves are to see that all pins

properly knocked down, be placed to their respective credit.

33d. The player in this game, as in billiards, has the sole right of looking after his own interests, and neither the gamekeeper nor any of the bystanders have any right to dictate to or advise him, unless by the consent of all the players.

34th. The gamekeeper shall collect the stakes, and make up the pool; deal out the small balls to the players; see that the balls and pins are properly spotted; that there are no more private balls out than there are players in the pool; and if any balls are missing, proclaim its number to the players—as the pool cannot be won by such ball;—call out each number in its turn to the players, and proclaim, loud enough for them to hear it, the number they already count, from pins knocked down.

35th. No person is considered in the game unless his stakes be paid in.

36th. All other contingencies not herein provided for, are to be referred to the gamekeeper, whose decision shall be final.

RULES FOR THE GAME OF ENGLISH POOL.

There are several ways of playing pool,—namely, with as many balls as there are players; or with two balls only, the players playing in turns, and with the alternate balls; playing at the nearest ball; playing at the last player; or the player playing at whichever ball he chooses. But the most popular mode is that in which the player plays at the last player. This is likewise the fairest way of playing the game.

The following are the rules for the game according to this last method :

RULES FOR POOL PLAYING AT THE LAST PLAYER.

1st. When colored balls are used in playing this game, the players must play progressively as the colors are placed on the marking-board, the top color being No. 1.

2d. Each player has three lives at starting. No. 1 places his ball on the winning and losing spot—No. 2 plays at No. 1—No. 3 at No. 2, and so on, each person playing at the last ball: unless it should be in hand, when the player plays at the nearest ball.

If a striker should lose a life in any way, the

next player plays at the nearest ball to his own; but if his (the player's) ball be in hand, he plays at the nearest ball to the centre of the baulk line, whether in or out of the baulk.

4th. Should a doubt arise respecting the distance of balls, it must (if at the commencement of the game, or if the player's ball be in hand) be measured from the centre spot in the circle; but if the striker's ball be not in hand, the measurement must be made from his ball to the others; and in both cases it must be decided by the marker, or by the majority of the company; but should the distances be equal, then the parties must draw lots.

5th. The baulk is no protection at Pool under any circumstances.

6th. The player may lose a life by any one of the following means:—by pocketing his own ball; by running a coup; by missing the ball; by forcing his ball off the table; by playing with the wrong ball; by playing at the wrong ball; or by playing out of his turn.

N.B. A life is lost by a ball being pocketed, or forced off the table by the adversary.

7th. Should the striker pocket the ball he plays at, and by the same stroke pocket his own, or force it over the table, *he* loses the life, and not the person whose ball he pocketed.

8th. Should the player strike the wrong ball, he pays the same forfeit to the person whose ball he should have played at, as he would have done if he had pocketed it.

9th. If the striker miss the ball he ought to play at, and strike another ball, and pocket it, *he* loses a life, and not the person whose ball he pocketed; in which case, the striker's ball must be taken off the table, and both balls should remain in hand, until it be their turn to play.

10th. If the striker, whilst taking his aim, inquire which of the balls he ought to play at, and should be misinformed by any one of the players, or by the marker, he does not lose a life; the ball must, in this case, be replaced, and the stroke played again.

11th. If information is required by the player, as to which is his ball, or when it is his turn to play, he has a right to an answer from the marker, or from the players.

12th. When a ball or balls touch the striker's ball, or are in a line between it and the ball he has to play at, so that it will prevent him hitting any part of the object-ball, they must be taken up until the stroke be played, and after the balls have ceased running they must be replaced.

13th. If a ball or balls are in the way of a striker's ball so that he cannot play at his ball, he can have them taken up.

14th. When the striker takes a life, he may continue to play on as long as he can make a hazard, or until the balls are all off the table, in which latter case he plays from the baulk, or places his ball on the spot as at the commencement.

15th. The first person who loses his three lives is entitled to purchase, or, as it is called, to star (that being the mark placed against his lives on the board to denote that he has purchased), by paying into the pool the same sum as at the commencement, for which he receives lives equal in number to the lowest number of lives on the board.

16th. If the first person out refuse to star, the second person may do it; but if the second refuse, the third may do it, and so on, until only two persons are left in the pool, in which case the privilege of starring ceases.

17th. Only one star is allowed in a pool.

18th. If the striker should move another ball whilst in the act of striking his own ball, the stroke is considered foul; and if by the same stroke he pocket a ball, or force it off the table, the owner of that ball does not lose a life, and the ball must be placed on its original spot; but if by that stroke he should pocket his own ball, or force it off the table, he loses a life.

19th. If the striker's ball touch the ball he has to play at, he is then at liberty either to play at it or at any other ball on the table, and it is not to be consid-

ered a foul stroke: in this case, however, the striker is liable to lose a life, by going into a pocket or over the table.

20th. After making a hazard, if the striker should take up his ball, or stop it before it has done running, he cannot claim the life, or the hazard, from the person whose ball was pocketed; it being possible that his own ball might have gone into a pocket if he had not stopped it.

21st. If, before a star, two or more balls are pocketed by the same stroke, including the ball played at, each having one life, the owner of the ball first struck has the option of starring; but should he refuse, and more than one remain, the persons to whom they belong must draw lots for the star.

22d. Should the striker's ball stop on the spot of a ball removed, the ball which has been removed must remain in hand until the spot is unoccupied, and then be replaced.

23d. If the striker should have his next player's ball removed, and stop on the spot it occupied, the next player must give a miss from the baulk to any part of the table he thinks proper, for which miss he does not lose a life.

24th. If the striker has a ball removed, and any other than the next player's ball should stop on the spot it occupied, the ball removed must remain in hand till the ball on its place be played, unless it should happen to

be the turn of the one removed to play before the one on its place, in which case that ball must give place to the one originally taken up; after which it may be replaced.

25th. If the corner of the cushion should prevent the striker from playing in a direct line, he can have any ball removed for the purpose of playing at a cushion first.

26th. The two last players cannot star or purchase; but they may divide, if they are left with an equal number of lives each; the striker, however, is entitled to his stroke before the division.

27th. All disputes to be decided by a majority of the players.

28th. The charge for the play to be taken out of the pool before it is delivered up to the winner.

THE NEAREST BALL POOL.

In this Pool the players always play at the nearest ball out of the baulk; for in this Pool the baulk is a protection.

1st. If all the balls be in the baulk, and the striker's ball in hand, he must lead to the top cushion, or place the ball on the winning and losing spot.

2d. If the striker's ball be within the baulk line, and

he has to play at a ball out of the baulk, he is allowed to have any ball taken up that may chance to lie in his way.

3d. If all the balls be within the baulk, and the striker's ball not in hand, he plays at the nearest ball.

All the other rules of the former pool are to be observed at this.

INSTRUCTIONS TO THE MARKER,

FOR KEEPING COUNT OF THE AMERICAN, OR FOUR BALL GAME.

1st. Give the striker TWO for pocketing his opponent's ball, or for caroming on a white and red.

2d. Give him THREE for each red ball pocketed, or for a carom on the two red balls.

3d. Give him FOUR for caroming on a red and white, and pocketing his opponent's ball.

4th. Give him FIVE for caroming on all the balls, no matter in what order they are touched; also, five for holeing a red ball and caroming on his opponent's, and five for caroming on the two red balls and pocketing his opponent's.

5th. Give him SIX when he caroms on the two red balls, and pockets one of them.

6th. Let him have SEVEN when he caroms on a white and red ball, and pockets both; the same when he caroms on all the balls, and pockets the white.

7th. For pocketing one of the red balls, and caroming on all the others, let him have EIGHT; also for caroming on the two reds, pocketing one of them, and also his opponent's ball.

8th. Give him NINE for caroming on the two reds, and pocketing them.

9th. For caroming on all the balls and pocketing a red ball and his opponent's, give him TEN.

10th. For caroming on all the balls and pocketing the two reds, let him have ELEVEN.

11th. Let him have THIRTEEN (the highest figure that can be won by one stroke in this game) when he caroms on all, and pockets all the balls, except his own.

12th. Give his adversary ONE when the player makes a miss, or fails to hit any of the balls on the table with his own.

13th. Give his opponent TWO when the player's ball jumps over the side of the table, or lodges on the top of the cushion after it has struck a white ball ; TWO, also, if the player pockets his own ball after touching his opponent's.

14th. The opponent takes THREE when the striker pockets his own ball, without touching any other on the table, or after it has touched a red ; or causes it to jump off the table or lodge on the cushion, under the same circumstances.

CHAPTER VI.

GENERAL SUMMARY OF INSTRUCTIONS.

IN the foregoing pages our sole object has been to assist the student by such simple and practical instructions as, with the assistance of the diagrams, would facilitate his acquirement of the true principles and execution of the game. We might have given accomplished players a higher estimate of our individual proficiency, had we entered into the minutiae of problems which are possible, but most difficult of attainment. But, in order to secure simplicity and usefulness, it became necessary to sacrifice whatever personal advantage this latter course might have produced. Our book is designed as an aid to amateurs, and not as a test for the capacities and expertness of professional or first-class players. These latter must be well aware, from experience, that there are delicacies and mysteries of execution which they accomplish daily, but could no more be described in words, than the last finishing touches with which the painter gives life and individuality to the dead features of his portrait. We have before said, and again repeat, if possible more emphatically, that the novice, to profit by our labors, must either put himself at first under the tuition of a competent master, or study our problems with the cue in one hand and the book on the table before him.

Let the quantities of power be practiced with patience, until they are thoroughly acquired; every hour devoted to obtaining mastery of the strength and direction of the cue, will save months of miserable failure in the different experiments of the game. Let the student, also, practice the different kinds of strokes—force, follow, jump, and so forth, separately, devoting a certain time to each, and not passing on to the next until he has mastered the preceding one, and taken good note of the varieties of angles which, under different circumstances, it will produce from the cushion. By trying them one after another, instead of each by itself, the results become as inextricably confounded as the different flavors of a French ragout. The cushions are to billiards what the chords are to music; until their properties are understood, no equable and harmonious play can be established.

These remarks are specially applicable to any player who aspires to a knowledge of “nursing,” in its billiard and not babyish sense. By mastering the Quantities of Power, and making such deductions as experience will shortly teach for the loss of strength imparted to the object-ball, the player will eventually be enabled to manage and foretell precisely in what positions the balls will be left at the end of a contemplated stroke. If that position be one from which no further advantage to him can be hoped; or one which—should he fail in his immediate object—would leave the balls arranged that his adversary might reasonably expect a fine opening; or should any other, even more difficult mode of play occur to him, in which, if suc-

cessful, a much finer disposition of the balls would be left, or a disposition much less favorable to his adversary; in any one or all of these contingencies, discretion will be found the better part of valor, and in the end it will appear that, not the brilliancy, but the persistent good judgment of the shots will carry off the palm.

This art of nursing the balls is indeed the most difficult attainment and crowning glory of the game: to discover when the balls are separated to the four corners of the table, some device or series of devices which, with good execution, will gradually bring them nearer and nearer, finally bringing them within one corner or against a cushion, where the least touches of the cue will make a succession of caroms; or where a vigorous stroke will make some one of them travel over a great space, and yet come back to its cluster as infallibly as the young birds to the nest; or where this is impossible—no further run to be made and the count exhausted—then to scatter them over the table in worse than Siberian exile one from another, so that the player who succeeds may inherit only a barren kingdom;—in these things consists the highest excellence of the judicious player, and he who can do these things best is certain of success in the course of continuous play. The danger of this art, however, unless the player feel very sure of his own skill, is serious and not lightly to be incurred. Should he bring the balls together and then, by a miss, so leave them for his opponent—he may look out for a run which will slightly damage his chances of the game. Wherever

here is danger of his missing the next shot, it would be prudent rather to separate the balls in the worst position possible for the succeeding player, and wait patiently for another chance.

It should always be borne in mind that the game will not be decided by the player's capacity to perform any particular stroke ; the most brilliant shot is a mistake, if it does not leave the balls in a position from which another count can be effected. Let the student, while he plays for the stroke before him, keep an eye on the ensuing stroke, of which *that* stroke will be the father ; let him see to it, that this offspring shall not be a disgrace and expense to him. When the balls are so placed that no count can be reasonably expected, then play for safety, and divide the balls in the way least likely to turn to your opponent's profit.

The student, moreover, should avoid the dangerous temptation of playing hard for a "scratch." Let him invariably play for some definite object, and then, should he fail, he will have learned something that may insure success another time ; but the scratch game does away with all ideas of scientific proficiency, and every count so acquired is a positive obstacle in the path of any future and permanent progress. The fable of the hare and the tortoise is an old one, but it will receive new confirmation if two novices commence—the one playing as we direct, and the other playing for the chances. After a few months' steady study of the different kinds of stroke, and quantities of balls, our pupil would then commence the actual play, and the advantages which would quickly place him

in the front rank of scientific players ; while the other would be years before attaining the average proficiency, and never could hope for a higher rank, until he unlearned the absurdities of his own teaching, and had gone back to the point from which the other started.

Remember, always, that a game is never lost until the last point has been strung off: if your adversary be a long way ahead of you, it is all the more your duty to take advantage of those careless strokes, into which his apparent superiority will be likely to betray him. Deal tenderly with your opponent's ball; do not pocket it, if any other play will serve your purpose; if it be tucked under the cushion, reflect on the stroke that is to follow, before you disturb its dreams; and bear in mind that it is better to play for two and win, than for thirteen, which you will be likely to miss. It is easier, also,—or if not, it is at least much better—to chalk your cue and strike, than to make a miscue and then chalk. Our final advice to the learner is, to take sufficient time and care to insure success to his stroke.

The author would indeed be ungrateful, did he fail to acknowledge the kind and valuable help which has been given him, both by amateurs and professional friends, in the compilation of this treatise. He would gladly acknowledge his indebtedness to each by name, were it not that he knows they are of the class who

“Do good by stealth, and blush to find it fame.”

Let them, therefore, take the will for the deed; and believe us, that for their friendly help and many gener-

ous favors, not only in this, but in all other matters wherewith we have been professionally connected, we thank them with a sincerity which is too deep and fervent to be expressed in such words as are ours to offer.

To conclude—for the writer makes no pretence to the refinements of authorship, and his language, here and there, may be open to unfriendly criticism—he would say that the theories and principles laid down in the foregoing pages have been those he himself has followed, during a career which, in its own humble way, has not been unattended with distinction; and if any professional *litterateur*—or professional player, for the matter of that—should take exception to any of the matters which he has here laid down, as the result of his own experience, he can only say that he will be happy to meet them in his own, or any other billiard saloon where the tables are correct, and decide the question in dispute by a direct appeal to the balls. However insignificant he may be with a pen in his hand, he flatters himself that with a cue he would be able to teach a majority of his critics a lesson it would profit them to know. They might teach him “the whole duty of man,” upon paper; but, on the tables, he could teach them the whole duty of a billiard-player.

APPENDIX.

THIS article, it will be observed, was written previous to the granting of Mr. Phelan's patent; and for the generous appreciation of his improvements here exhibited, the author takes this public opportunity of returning his heartfelt thanks to the disinterested editors of that eminent and justly popular journal. He confesses he is vain enough to think that his improvements, from their palpable and intrinsic merit, and from the general dissatisfaction with which the old style of billiard-tables and cushions were regarded, must eventually have won their way to public approbation and adoption: but he is equally, if not more confident, that the recommendation given from so high a source, did much to facilitate their adoption and secure them that honest trial which was all he asked, and which—as the event has proved—was all he needed for success.

“IMPROVED BILLIARD-TABLES AND CUSHIONS.”

(From the Scientific American, December 23d, 1855.)

“The accompanying engravings illustrate an improvement in Billiard Tables, invented by Michael Phelan, 39 Chambers street, this city, who has taken measures to secure a patent.

“Fig. 1 is a perspective view of the model table and combination cushions, partly showing the improvements—their construction and the shape of the pocket-irons—“jaws”—and sights, and the inventor would take this opportunity of calling the attention of all disciples of the beautiful and scientific game of billiards to the inspection of these diagrams and the brief explanations accompanying them. He feels confident that he has accomplished that which

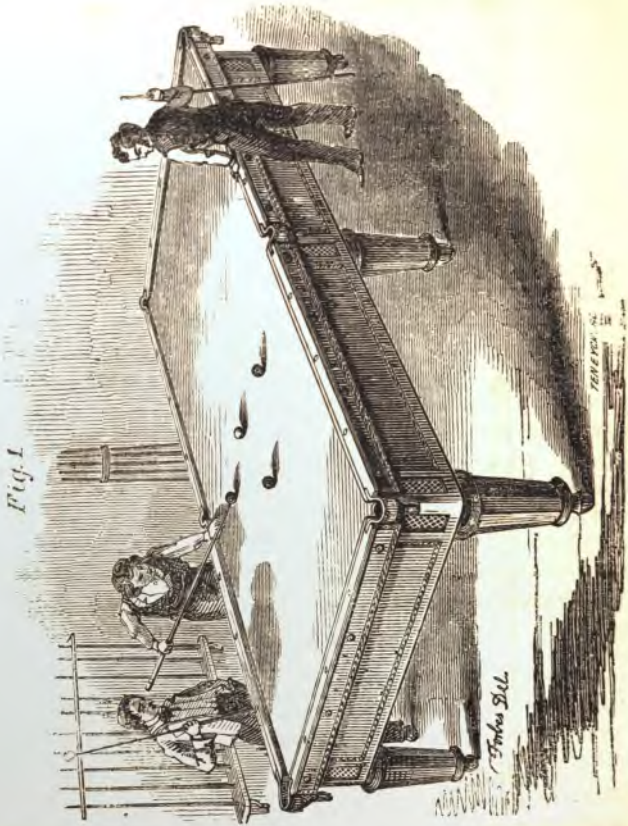

has occupied the attention of billiard-table manufacturers, on the one hand, and all scientific players on the other—an improved cushion for the table, with cushions possessing the requisite elasticity and correct angles when played on.

a diagram, showing a top view of the bed, cushions, and rails of a billiard table; this diagram illustrates the angles

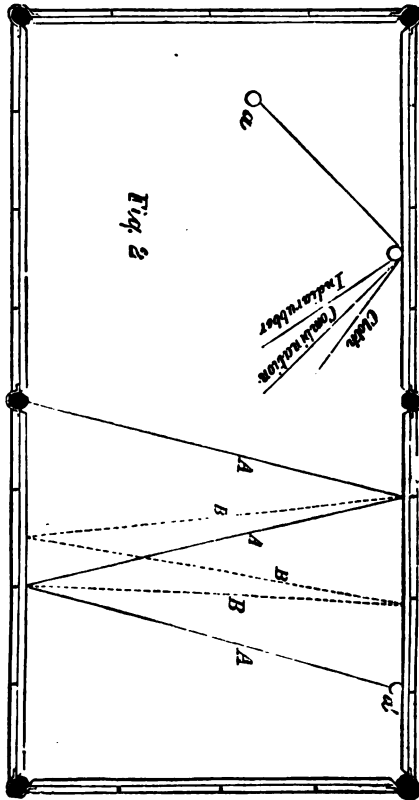

produced by a "stroke" of equal strength when played on the "combination" cloth and India-rubber cushions. The example is, a ball played from the centre of the side pocket over line *a* to the point on the opposite cushion with sufficient strength to make it rebound to the side from which it started, and back again. On the combination cushions it will describe the angles marked *A A A*, on the diagram, which evidently are correct angles, the base of both being equal. But on the India-rubber cushions, the ball, if played

with the same force, produces angles to correspond with the dotted lines marked B B, and if played with an increased force, it will finally return in a direct line parallel with the end cushions, when, if correct angles had been produced, the ball would have returned to the corner pocket opposite to the ball marked *a* at the termination of the line A.

"The second example is intended to illustrate the difference of the angles produced by a stroke on the cloth, combination and India-rubber cushions; play ball *a* against the cushion as represented in diagram, with a moderate degree of strength, and the angles produced on the different cushions named will correspond with those lines marked "cloth," "combination," and "India rubber;" the cloth cushion will produce an angle too obtuse, the India rubber an angle too acute, while the combination cushion will produce a correct right angle; this can be proved by actual demonstration on the different tables. For the purpose of illustrating the cause of this, the reader is referred to figs. 4, 5 and 6, which are sectional views of the different cushions named.

"Fig. 3 is a view of one corner of the model table, showing the improvements introduced in the shape of pockets, pocket-irons, and "sights" or "nails" by which the great inconvenience of the "old school tables" are entirely obviated; also the improvements in the shape of cushions. *a* shows the shape of the jaws. *b* is the cue in a horizontal position, and *c* shows the shape of the jaws in old style. In fig. 4, *a* shows the manner the cue has to be elevated on the old style of cushions; *b* is the sight; *c* the India-rubber tube, and *d* the ball. *a*, fig. 5, is the cue in a horizontal position. *b* is the sight inserted level with the cushion. *c* exhibits the manner in which the cushion is secured; *e* is the ball.



"Figures 5 and 6. The combination cushions are half an inch lower than the old style cushions; this is of the greatest importance, for when the ball is at rest close to it, it can be struck and played with almost the same facility as if it were at any other part of the table,

enabling the player to play with his cue in nearly a horizontal position, (fig. 5) and not be obliged to elevate it as the cue is represented by *a* in fig. 4. Another improvement is the nails or sights marked *b b*. In the old style (fig. 4) they project above the cushion and interfere with many strokes during the play. In fig. 5 they are inserted in, and level with the surface of the cushion; the pocket-irons, also, are level with the surface of the combination cushions, thus allowing the player to strike the ball when in the position represented in fig. 3, with the cue *b* perfectly horizontal. These improvements will be obvious to all good billiard-players. The most important, perhaps of all, is the difference in the shape of the pockets. The dotted lines, *c c*, at each side of the pocket, fig. 3, are intended to show the difference between the shape on the old style and those on the model table. By constructing the "jaws" of the pockets in this style there is an additional surface of some thirty inches more of correct cushions added to the space to be played on, over and above that on the old style tables, and many strokes can be made that would be impossible on the old ones. Again, there is no deceptive appearance presented to the player when playing a ball at a pocket as there is on the old, wide gaping "jaws," which do not "take" a ball as easily as those on the model tables. *c c*, fig. 3, therefore, shows the old style shape of the pocket, and *a* the new style on the combination cushion. There is at least five inches more cushion on each pocket of the new, or thirty inches on the whole. Fig. 4 is a sectional view of the India-rubber cushion, known amongst the billiard-table makers as the "pipe" or "tube" cushion. It is composed of a long round strip of rubber, sometimes hollow and sometimes solid, as they wish to increase or diminish the degree of elasticity. The ball, *d*, is represented in contact with it. When the ball comes in contact with the rubber it sinks in, or is embedded in it more or less, according to the degree of force with which it may be impelled; the greater the force the more the rubber is compressed, and the more the ball is embedded, and this sinking in or embedding of the ball, together with the extreme elasticity of the rubber, is the cause of the angle produced by the rebound, being acute, and so much at variance with correct angles. Fig. 5 is a sectional view, representing the new "combination" cushion, in which the inventor, after a series of experiments, has succeeded in producing an article in which the objections referred to in the old table are entirely obviated, and in which other important improvements are introduced. The "combination" cushion, that is, the portion of it which causes the rebound of the ball after contact with it, is composed of three different materials (not including the cloths for covers) by which a cushion elastic at its back and comparatively solid, yet pliable at its face, is produced, thus preventing the ball

sinking in, and yet retaining the elasticity of the substance marked *d*. These three substances are of different degrees of elasticity, and are so combined and graduated as to produce angles in accordance with scientific principles.

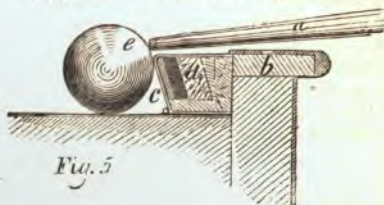
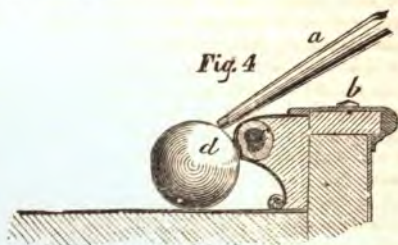

" Fig. 6 is a sectional view of another India-rubber cushion called the "English pattern." *d* is the ball, *c* the India rubber, and *b* the sight. Some persons engaged in the manufacture of what they call billiard tables are using it, and talk about correct angles, without well knowing what they mean. This cushion is

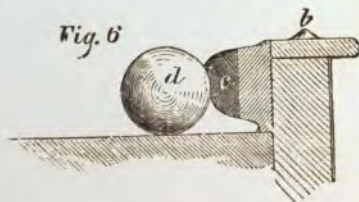

simply a strip of rubber of the shape represented; and the same actions exist in this as in the "pipe" or "tube" cushion, viz., bedding of the ball, and too much elasticity; at all events,

the test is the angles, and they are found to give angles at variance with all known geometrical principles. This figure also serves to illustrate the shape of the old-fashioned cloth cushion, composed of long strips or layers of cloth stretched parallel with the cushion rail; they are now nearly out of use, as the "pipe," "tube," and English pattern will be, as soon as the advantages of the "combination cushions" become generally known.

"It is a well-known fact among scientific billiard-players, that speed and truth cannot be obtained in a cushion. Beyond a certain degree of elasticity in a cushion, the more incorrect it becomes. When we say speed, we mean the ridiculous railroad pace lately brought into use in public billiard-rooms, and which meet the approval of those only who are advocates for chance hazards or caroms; while to the player who calculates upon, and who is accustomed to geometrical demonstration, it is painful to see the beautiful and scientific properties of the game disgraced.

"The 'Combination Cushions' are fast enough for every purpose of scientific play; and by playing on a table constructed as just described, a knowledge of the game would be more easily acquired, whilst a greater number of points could be made from the balls; by using them, the proprietors of billiard-rooms would, we think, find players of merit more anxious to contend and test the strength of their games."

The following, from the same paper are descriptive of the improvements in these tables, for which patents have recently been granted.

COMBINATION BILLIARD CUSHION.

"The patent granted this week to M. Phelan and H. W. Colender, of this city, is for an improved mode of carrying out a principle in billiard cushions covered by a former patent, secured in 1856, by Mr. Phelan, and illustrated in the *Scientific American*, vol. xi. page 116.

"The present improvement consists simply in the combination of two rubbers of different degrees of density, the hardest rubber being the face, and the softest the foundation of the cushion. The advantage of using a denser rubber as a facing, instead of a cork, steel, or whalebone facing, is this: It possesses within itself a property whereby it and the rubber foundation can readily be united. It is also superior to a steel strip or whalebone, because it presents a denser surface of such a nature as will avoid the disagreeable

bang of the steel or whalebone strip, and which will "grip" the ball so as not to injure its correct reflection, and yet give a greater effect to the "twisting shots." It likewise prevents the ball sliding off at an incorrect angle, when played at a very obtuse angle against the cushion.

"As Mr. Phelan has the reputation of being the best billiard player in the United States, and understands the requirements of the table, his improvement must commend itself to those of the public, who play this almost national game."—*Scientific American*, Dec. 19, 1857.

"H. W. Collender, of 53 Ann Street, this city, has patented an improvement in Billiard Cushions, which consists in uniting the comparatively solid strip of rubber, gutta percha, steel or whalebone, to the elastic or spring foundation, by placing the comparatively solid substance in a mould, and allowing the melted rubber to flow against, or the plastic rubber to be pressed around, or in contact with the same, so that it shall surround the edges, back, and ends of the same, and thus securely confine it, without the necessity of using cement, nails, hinges, or any cloth covering to retain it. We regard this as a very valuable improvement in the manufacture of the cushion, and like former inventions of Mr. Collander, in this branch of the arts, it commends itself to the public."—*Scientific American*, Jan. 23, 1858.

The principle discovered and propounded in Mr. Phelan's earliest patent, to wit, that a billiard cushion, to combine speed with correctness, should have a comparatively solid facing, and the springs or elasticity in its back, has been admitted by all manufacturers, and they have unsuccessfully endeavored to pirate that discovery by using strips of gutta percha, whalebone, leather, steel, &c.; but the concussion of the ball has displaced all these, and it has been found impossible to keep such tables in order. Tables so made, moreover, gave out an unpleasant sound or bang whenever struck.

The new combination gives the simplest and most perfect embodiment of this principle in a form that can never be put out of order, and which obviates (if it ever existed) *the only solitary objection ever heretofore urged* against the first combination of cork, rubber and leather, by which Mr. Phelan carried out his discovery into practicality.

This new invention, too, has the advantage of forming one homogeneous whole—a cushion, in which the parts, though of different consistencies, are the same and inseparable. A mere hard face could be obtained by strips of steel or whalebone, but these become separated by the constant shocks of the balls; and even those manufacturers who adopted them—thus, hoping to pirate Mr. Phelan's principle, while avoiding the penalties for infringement of his patent, have been forced to abandon them, after finding that a few weeks, or sometimes *hours*, would set their "machinery" out of order.

PHELAN'S IMPROVED BILLIARD CUSHIONS

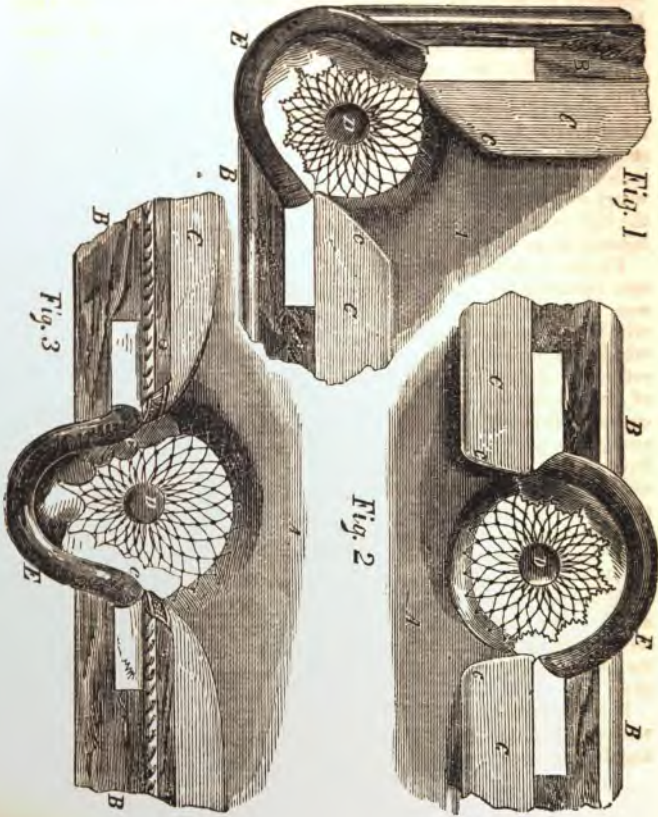

Our illustration represents a great improvement in the form of billiard cushions, which is intended to overcome two great evils that attend the ordinary construction. Figure 3 is the old form of cushion and pocket. A is the table, B the side, and C the cushion; D the pocket, and E the pocket-iron, covered as usual with leather. In this form of cushion, it will be seen that it is gradually sloped off from its proper width to the pocket, and the player, when his ball strikes any portion of the sloped part, can never be exactly certain of the angle at which the ball will re-bound; by this means, a great quantity of accurate reflecting surface is lost to the player. Again, when a ball enters a pocket, it is almost sure to strike the pocket-iron at one of the points marked *c*, and in practice, it is found that the leather covering of the pocket-iron quickly wears away from those points, leaving the metal bare against which the ball strikes, and becomes in consequence, quickly worn out and injured, so as to be unfit for playing.

Figure 2 shows a side pocket on the new principle, the same letters referring to the same parts as in figure 3, in which it will be seen that the cushions, C, are extended perfectly even in their width, close to the pocket-hole (as will also be observed in figure 1, which is a corner pocket on this plan), so that a greater amount of reflecting surface is obtained; for the Game of Billiards is not one of chance, but one of mathematical precision and accuracy. The cushions turn off abruptly at a slight angle to the pocket, just enough to give a clear entrance to the ball, and of such a shape from the corner of *c*, that should the ball once strike these, it cannot fail entering the pocket; and they also project about one-eighth of an inch in front of the pocket-iron. The shape of the pocket-iron has also undergone a material change in shape; it is, as will be seen, perfectly concave, and there is no part which can possibly be touched by the ball, but the moment it enters the space between the cushions, it is sure to fall into the pocket without touching the iron at all. We regard this as a great and important improvement in the billiard table, and will, no doubt, be thoroughly appreciated by the numbers who take delight in this popular and almost universal game.

It is the invention of Michael Phelan, of New York. A patent was secured January 12, 1858, for the shape of pocket-irons and angular cushions, combined or separate.

To this Poem we have made due reference in the text, at its appropriate place. The verses originally appeared in the *Billiard Cue*.

“ATTITUDE IS EVERYTHING.”

In very slight things a man's idiosyncrasy
Slyly peeps out, and we havn't a doubt
That many a man whom his neighbors may think crazy,
Only displays in more notable ways
Some peculiar distinguishing characteristic,
Which, were it at all like our own, we should praise,
But severely condemn when 'tis antagonistic.

These distinguishing traits are most forcibly shown
In a game, which of late, has most popular grown ;
A very correct psychological steelyards
For character weighing—of course, we mean billiards
E'en attitude, sometimes, may give us a *cue*
To a man's inner life ; so, dear reader, if you
Havn't any objections, we'll *hazard* a few
Illustrations, by which we'll endeavor to prove
The truth of the statements we've ventured above



The first we select from th' incongruous mass,
Is a strongly marked type of a numerous class :

The young man, who, his exquisite elegance shows
 By the studious grace of his delicate *pose*,
 And who handles his cue with so dainty an air,
 That you're forced to agree with his friends, who declare
 His games "very pretty to look at," although
 In the matter of counting, 'tis only so so.

As a contrast, we next your attention will claim
 For the athletic player, whose vigorous frame



Makes him play what is commonly called a "strong game;"
 Who always declares that "there's six on the balls;"
 Sends them all round the table 'till one of them falls
 Into one of the pockets—he doesn't much care
 Into which; for, as every one's fully aware,
 In love, war, and billiards, all chances are fair;
 And as to his caroms, you safely may swear
 If there's one on the table, he's sure to be "there;"
 For his ball goes so fast, that, unless it should drop
 In a pocket, it's very safe never to stop
 Until one of the others, (fulfilling the laws
 Of physics, which show each phenomenon's cause.)
 By assuming its motion, compels it to pause.

The third we advance to the threshold of fame
 Is the young man, *que voici*, who "plays his own game:"
 Who displays at his *scratches* no kind of remorse,
 And eternally tries some impossible "force,"
 Which results in a *jump* and a *follow* combined:
 While his cue, at a "forty-five" angle inclined,

As if conscious of *sad* disgrace, seems nothing loth
To hide half its length through a hole in the cloth.



Turn we next to the youth whose deliberate game
Is displayed in the pause that he makes ere his aim



Is finally taken :—His cue raised in air,
He scans ev'ry angle and cushion with care ;
Studies all of his shots in their smallest details,
Then, proceeding to execute,—commonly fails !

We pass to a player who's quite the reverse
Of the last, and, if such a thing's possible, worse :
We allude to him, who—after striking his ball,
Finds it requisite over the the table to sprawl ;
And makes with his cue little comets of chalk
On the cloth as he follows his shot :—Then he'll walk

Up to some of his friends, and, extending his hand,
Proclaims loudly that "Really, he can't understand



How so simple a carom he failed to do right,
For he saw *Phelan* make the shot, only last night!"

Then, again, there's the man, from whom Heaven preserve us,
Whose careful aim makes his antagonist nervous :



Who saws with his cue, until really you wonder
He don't saw his thumb and fore-finger asunder ;
If you watch him, you'll find, ere it comes to your chance,
You're performing a sort of St. Vitus's dance.

There's the player, too, who, when he misses a count,
Of profanity utters a startling amount :
His toe cocked in air with an exquisite grace,
And the greatest anxiety marked on his face,

He looks half way between a "young man about town,"
And George Christy about to commence a break-down ;

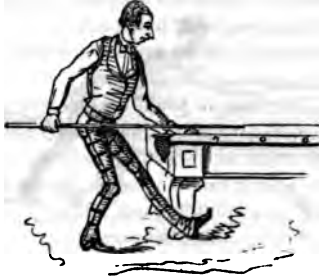

And he swears—how he swears!—when to count he's not able—
At leather, chalk, cue, cushions, cloth, balls, and table :
And if his opponent should happen to "scratch it,"
Perhaps he's not morally certain to "catch it."

Who's this? who distorts all his human proportions
By the wildest of wild calisthenic contortions?
Is't a maniac? No, gentle reader, not so :
'Tis the man who points out where his ball ought to go,



By twisting his head, arms, and body about ;
And who startles your ears with a lunatic shout
As he screams at the balls, to "go in" or "keep out ;"

When one of his efforts successfully ends, he
Howls, dances, and raves in a regular frenzy.
But if his attempts chance to finish in failure,
Groans, dismal as dirges, and deep growls assail your
Auricular organs, as, sunk in despair,
He writhes himself into the nearest arm-chair.

And now, reader dear, if you'll lend us your ear,
We'll tell you, in confidence, how to keep clear
Of all of the errors we've held up to view,
And, without absurd habits, to manage your cue.

 If you think it worth while
 To play billiards in style,
And make "*running*" that's only surpassed by the Croton,
 As Cuttle would say,
 In his forcible way,

"Overhaul PHELAN's book, and when found, make a note on!"

The following little *jeu d'esprit* from the pen of a distinguished dramatist and actor, which originally appeared in the *Billiard Cue*, we feel tempted to reproduce here—assured that its ingenuity cannot fail to amuse the reader.



HAKSPEARE A BILLIARD PLAYER.

We have stumbled on a most important discovery ; or rather a most important discovery has at length been made by our critical and protracted investigations. We have found beyond controversy that the "sweet Swan of Avon" was a most devoted billiard player ; and that nearly every term employed in the game is a *direct quotation* from the writings of that immortal bard. In every play of his, there are allusions to the game, and in every allusion he proves himself its master ; not one of its intricacies has escaped his all-seeing eye. "Let us to *billiards*," he exclaims, in *Antony and Cleopatra*, (Act II., scene 5.) "My *cue* is villainous," he complains in *King Lear*, (Act I. scene 1.) "Why these balls *bound*," or "jump," he indignantly cries in *All's Well that Ends Well*, (Act II. scene 3.) "I did present him with those *Paris balls*," he announces in *Henry the Fifth*, (Act I. scene 2.) thereby proving that French balls and cues were then thought better than English. "When my *cue* comes, call me," he orders in the *Midsummer Night's Dream*, (Act IV. scene 1.) from which we may judge that he had sent it to whoever was then the "King of the Billiard Leatherers" for a new top. "Every one according to his *cue*," he adds in the same play, (Act III. scene 1.) meaning, doubtless, that a man should proportion his "strength" to the weight of the cue with which he plays. "Remember you your *cue*?" he inquires in the *Merry Wives of Windsor*, (Act III. scene 3.) thereby insinuating that

every first-class player should have a private or peculiar cue, the weight and force of which he might remember. Speaking of the old style of cushions, he denounces them in *Coriolanus*, (Act V. scene 3.) as "*cushions* no softer than the flint," and then turning prophetically towards Michael Phelan, he begs in his most solemn manner, (same play, Act. III. scene 1.) "*Let them have cushions by YOU!*" He is familiar with such terms as "hazard," "lead," "scratch," "light spot," "Billiard sharp," and so forth; in fact, we may say with truth that he is "fully posted." "Take your *hazard* back again," he says to some brother player in the *Merchant of Venice*, (Act I. scene 1.) "Your *hazard* shall be made," he again exclaims in the same play, (Act II. scene 1.) as if to encourage a hesitating partner. "Nor *hazard* aught for *lead*," he continues in the 7th scene of the same act—showing clearly enough, (what indeed we would expect from his wisdom,) that he did not consider the mere "lead," *per se*, worth "stringing" for. That he was partial to "hazards," we may infer from what he says in *King John*, (Act V. scene 6.) "I will upon all *hazards* well believe;" and we account for the preference when we remember that, as "cushions" had not then been much improved—being in fact "no softer than flint," as he himself says—the more delicate beauties of "the carom game" could not possibly have been known to him. In *Timon of Athens*, (Act V. scene 5.) there occurs a word which we believe our readers will agree with us in regarding as a printer's error, (and it is confessed that there are thousands of such, even in the most careful editions of Knight and Collier.) It ought to read, "and by the hazard of the *spotted ball*;" but for "ball" the word "die" has been falsely interpolated in a majority of the editions. "I understand *kisses*," Shakspeare proudly asserts in the first part of *Henry the Fourth*, (Act III. scene 2.) and that he knew the French Doublet or Cross-game is evinced by the phrase "the last of many *doubled kisses*," which we find in *Antony and Cleopatra*, (Act I. scene 5.) When some disappointed player cries "ay, ay, a *scratch*, a *scratch*," perhaps he is not aware that he is quoting *Romeo and Juliet*, (Act III. scene 1.) or should he vary the phrase, by saying, "that is but *scratched*," he may possibly not know that these words are taken from *Hamlet*, (Act IV. scene 7.)

"You cannot see the *white spot*," is a phrase in common use, but we put it back, and you will find it in the *Merry Wives of Windsor*, (Act IV. scene 5.) When the balls run along the cushion, we often

say, "when they do *hug*," and going back to Titus Andronicus, we find the same description in Act III. scene 1. "Would thou wouldst *burst*," yells Timon of Athens, (Act IV. scene 2.) and Timon, we know, was a "flat" who had probably got "cleaned out" by some "sharp" at "pool;" and this conjecture is strengthened by the confession in the Tempest, (Act IV. scene 1.) "but to lose our bottles in the *pool*," from which we may reasonably infer that the party had been playing for champagne. That they *had* been playing for something, we have proof in the same play, (Act I. scene 2.) where the poet says, "I pray thee *mark*," indicating that the marker was particularly requested to attend to his duties, as the "bottles" were depending on the issue. "I have *banked*," he says in King John, (Act V. scene 2.) and in King Lear, (Act V. scene 3.) he makes use of another term only appropriate to "pool," where he cries, "It is my *privilege*." In Romeo and Juliet, (Act III. scene 5.) he designates Billiard-Sharps as "unpleasing *sharps*," and in Henry VIII., (Act I. scene 8.) he speaks of "*honorable points*," as if in contradistinction to the "points" made by them. The cushions, as we have hinted, were poor, and not reliable in his time; and thus we see that in Winter's Tale, (Act IV. scene 1.) he confesses, "I fear the *angle*"—meaning doubtless, the incorrectness of the angle of reflection on the board. How triumphantly does he shout in Julius Cæsar, (Act IV. scene 3.) "I put it in the *pocket*;" and if the foregoing extracts are not enough to convince the most incredulous that Shakspeare was a billiard player, and played a pretty strong game in his time, then we can only promise that another sheaf of extracts and quotations shall be given in our succeeding issue.

Vive la bagatelle! which, in English, means three cheers for Billiards!







