

258
72
No. 8017-403



GIVEN BY

W. S. Supt of Documents

OFFICE OF INDIAN AFFAIRS

FARM AND HOME MECHANICS

SOME THINGS THAT EVERY BOY SHOULD KNOW HOW TO DO
AND HENCE SHOULD LEARN TO DO IN SCHOOL

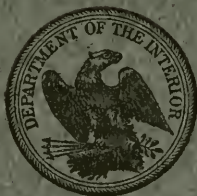

WASHINGTON
GOVERNMENT PRINTING OFFICE

1911

OFFICE OF INDIAN AFFAIRS

FARM AND HOME MECHANICS

SOME THINGS THAT EVERY BOY SHOULD KNOW HOW TO DO
AND HENCE SHOULD LEARN TO DO IN SCHOOL

*
8017.403



WASHINGTON
GOVERNMENT PRINTING OFFICE

.1911

e

U. S. GOVERNMENT PRINTING OFFICE
G. 1234 1234
Apr 21 1911

This publication is distributed free only to the officers of the United States Indian Service. Persons desiring copies for their personal use may obtain them from the Superintendent of Documents, Government Printing Office, Washington, D. C., for 15 cents.

VIARELLI CLUBIN
BN: 70
NOTES 70710

CONTENTS.

	Page.
Preface	5
Introduction	7
Lists of tools	9
Cost of equipment for wood-working classes.....	10
Split-log drag	11
How to use a drag.....	11
Setting posts	12
Building fence.....	12
Planting trees.....	12
Oiling and mending harness	13
Caring for farm and other tools.....	13
Pruning	13
Protecting trees	14
Putting handles in tools	14
Nailing on horseshoes	14
Sharpening plows	15
Mixing mortar	15
Laying cement walks	15
Laying stone wall	17
Hanging doors	17
Setting locks	18
Painting and glazing.....	18
Building roads	19
Glueing.....	20
Soldering	20
Harnessing, hitching, and unhitching horses	21

ILLUSTRATIONS.

	Page.
Plate I. Cheap workbench.....	48
II. Manual training workbench.....	48
III. Details of manual training workbench.....	48
IV. Domestic science cook table	48
V. Ironing board to be used with domestic science cook table.....	48
Fig. 1. Bread board	22
2. Stall, feed box, and manger	23
3. Hen's nest	24
4. Henroost.....	25
5. Gate	26
6. Chicken coop.....	27
7. Milk stool	28

	Page.
Fig. 8. Evener.....	28
9. Feed trough.....	29
10. Water trough.....	30
11. Wall shelf.....	31
12. Hanging shelf.....	32
13. Footstool.....	33
14. Flour box.....	34
15. Bench.....	35
16. Knife box.....	36
17. Table.....	37
18. Cupboard.....	38
19. Towel roller.....	39
20. Bedstead.....	40
21. Window screen.....	41
22. Door screen.....	42
23. Bookcase.....	43
24. Tool chest.....	44
25. Clothes box.....	45
26. Split-log drag.....	46
27. Hayrack.....	47
28. Details of a cheap workbench.....	48

P R E F A C E.

This publication has been compiled from the results of practical experience in the work of instruction in the Indian schools. It is believed that it is a comprehensive and practical manual that will be of material assistance to the teacher, but every teacher is urged to forward suggestions in order that the manual may be improved when a second edition is issued.

One word of caution is urged as to the use of this publication. The teachers should look at it in the light of suggestions rather than as dogma from which they should never deviate, and I should not want any teachers to feel that they could not take up any phases of the subject or any methods of instruction which are not contained in this publication. Conditions vary greatly in different localities and in the same locality at different times, and the teacher must ever be alert to meet these changes. Perhaps this word of caution is unnecessary, but the experience of many school systems goes to show that it can not be too strongly emphasized.

R. G. VALENTINE, *Commissioner.*

SOME THINGS THAT EVERY BOY SHOULD KNOW HOW TO DO.

INTRODUCTION.

Nearly every Indian boy when at home lives in the country rather than in town, and therefore is more or less closely in touch with farm life. The majority of these boys have their own land, and this majority should ultimately make their living from this land. To do that requires that they live the lives of farmers. There are many simple processes which the white boy who is brought up on a farm learns incidentally at home that the Indian boy has no opportunity to learn there, but which he must know how to do if he is to make a real success of his farming.

The boy who devotes himself entirely to a trade may become proficient in that trade, and yet may lack in the general knowledge of doing these common things that are so necessary to the farm and home.

A suggestive list is given containing a number of common articles that have to be made for every home and on every farm, together with a number of processes with which every boy should be familiar. There are localities to which not all of these suggestions may apply, and it will be desirable to add to this list some things that are applicable only to certain local requirements. It is not the purpose of the bulletin to furnish any complete list or complete course, but merely to give suggestions as to what may be done, with the expectation that the live instructor will add to the lists as his experience may show him is advisable.

The cuts contained in the bulletin will show how the more difficult articles are made and the description of the processes will be sufficient to give any instructor a good idea of what is to be done if he is not already informed on the subject.

The records should be kept on cards, as shown on the sample, and due credit should be given for everything that is done when the pupil has acquired the ability to do the thing independently. These records should show exactly what the pupil has done, not only in the way of completing the work as outlined but also in connection with his work in a regular trade, if he is taking such a course. The card should be filed in the pupil's individual folder with all other permanent records.

The earnest cooperation of all employees is requested in carrying out and adding to the plan as outlined.

Sample record card (face.)

Name..... Age..... Tribe.....
 Date of entry..... Term..... School grade.....

Article.	Date.	Process.	Date.	Remarks.
	1907.		1907.	
1	Sept. 25	1	Oct. 6	
7	Oct. 3	2	Nov. 13	
10	Oct. 15	9	Nov. 17	
2	Nov. 20	4	Dec. 15	
11	Nov. 20	5	Dec. 15	
12	Nov. 20	6	Dec. 15	
3	Dec. 10			
	1908.		1908.	
	Jan. 5	3	Apr. 17	
23	Jan. 5	17	June 12	
13	Feb. 2	11	Oct. 2	
4	Mar. 30	10	Dec. 15	
18	June 15			
17	Sept. 30			
	Oct. 25	21	1909.	
27	Oct. 25		Feb. 20	
31	Nov. 5	12	May 13	
14	Nov. 30	16	June 11	
20	Dec. 20	23	June 15	
		13	Oct. 18	
	1909.	19	Nov. 3	
5	Jan. 30	20	Nov. 3	
6	Feb. 25			
24	Mar. 29			
9	Apr. 19	18	1910.	
8	May 27	8	Jan. 7	
15	Oct. 3	14	Mar. 5	
26	Nov. 20	15	May 13	
		22	May 31	
		7	June 5	
	1910.		June 15	
19	Jan. 5			
22	Mar. 2			
33	Apr. 17			
34	June 15			

Sample record card (reverse.)

This card is to be used in recording the work done by each boy during his attendance in school. All of the articles mentioned may not be applicable to each individual and it may be desirable to teach other processes and the making of other articles in different localities, but whenever anything is made that is not in the list, or when anything practicable is taught that is not found there, these should be inserted with appropriate number and the proper credit given.

ARTICLES TO BE MADE.

- | | |
|--------------------------------|--------------------------------|
| 1. Bread board. | 16. Knife box. |
| 2. Stall, feed box and manger. | 17. Table. |
| 3. Hen's nest. | 18. Cupboard. |
| 4. Hen roost. | 19. Towel roller. |
| 5. Gate. | 20. Bedstead. |
| 6. Chicken coop. | 21. Window screen. |
| 7. Milk stool. | 22. Door screen. |
| 8. Evener. | 23. Bookcase. |
| 9. Trough, feed. | 24. Chest. |
| 10. Trough, water. | 25. Clothes box. |
| 11. Shelf, wall. | 26. Split-log drag. |
| 12. Shelf, hanging. | 27. Hay rack. |
| 13. Footstool. | 28. Cheap workbench. |
| 14. Flour box. | 29. Manual training workbench. |
| 15. Bench. | |

PROCESSES TO BE LEARNED.

- | | |
|---|--|
| <ol style="list-style-type: none"> 1. Setting posts. 2. Building fence. 3. Planting trees. 4. Oiling harness. 5. Mending harness. 6. Mending with rivets. 7. Caring for farm and other tools. 8. Pruning trees. 9. Protecting trees. 10. Putting handles in tools. 11. Nailing on horseshoes. 12. Sharpening plows. | <ol style="list-style-type: none"> 13. Mixing mortar. 14. Laying cement walk. 15. Laying stone wall. 16. Hanging doors. 17. Setting locks. 18. Mixing paint and glazing. 19. Building roads. 20. Putting culverts in roads. 21. Gluing. 22. Soldering. 23. Harnessing, hitching, and unhitching horses. |
|---|--|

LISTS OF TOOLS.

WOODWORKING TOOLS.

- | | |
|---|---|
| <p>Two-foot rule.
Carpenter's steel square.
Try-square.
T-bevel.
Dividers.
Claw hammer.
Plane.
Marking gauge.
Ripsaw.
Crosscut saw.
Chisel.
Drawknife.
Mallet.
Mortise gauge.</p> | <p>Auger bits.
Brace.
Spokeshave.
Screw-driver.
Gimlet bits.
Countersink.
Oilstone.
Oil can.
Vise.
Bench stop.
Bench hook.
Miter box.
Carpenter's horse.
Gluepot.</p> |
|---|---|

MASON'S TOOLS.

- | | |
|---|---|
| <p>Crowbar.
Edger.
Groover.
Mallet.
Mason's brush.
Point.</p> | <p>Pitching chisel.
Stone ax.
Trowel, mason's.
Trowel, plastering.
Trowel, pointing.
Ladder (to be made by students).</p> |
|---|---|

PAINTER'S TOOLS.

- | | |
|--|---|
| <p>Oval brush, No. 8.
Varnish brush, 2-inch.
Varnish brush, 3-inch.
Wall brush, No. 6.</p> | <p>Glass cutter.
Putty knife.
Sash tool, No. 2.</p> |
|--|---|

BLACKSMITH'S TOOLS.

- | | |
|---|---|
| <p>Shoeing hammer.
Pincers.
Trimming knife.</p> | <p>Ball peen hammer.
Cross peen hammer.
Horse rasp.</p> |
|---|---|

COST OF EQUIPMENT FOR WOODWORKING CLASSES.*Cost of individual equipment.*

1 work bench, as per accompanying drawings.....	\$32. 95
1 vise, rapid action, W. C. Toles & Co., Chicago (or equal), No. 55.....	7. 50
1 plane, jack, Stanley (or equal), Bedrock, No. 604.....	2. 00
1 plane, block, Stanley, Knucklejoint, No. 18.....	. 85
1 spoke shave, double cutter, 1½ inch, hollow and straight, No. 60.....	. 50
1 draw knife, White's (or equal), No. 31, 8 inch.....	1. 00
1 chisel, socket firmer, Buck Bros. (or equal), No. 35, ¼ inch.....	. 40
1 chisel, socket firmer, Buck Bros. (or equal), No. 35, ½ inch.....	. 45
1 chisel, socket firmer, Buck Bros. (or equal), No. 35, 1¼ inch.....	. 65
1 gouge, socket firmer, Buck Bros. (or equal), No. 42, outside bevel, regular sweep.....	. 55
1 bit auger, Genuine Russell Jennings (or equal), double spur, ¼ inch.....	. 30
1 bit auger, Genuine Russell Jennings (or equal), double spur, ½ inch.....	. 45
1 bit drill, twist, Syracuse (or equal), ⅝ inch.....	. 12
1 brace, Stanley (or equal), 10-inch sweep, ratchet, Sampson jaw.....	1. 75
1 screw driver, Champion (or equal), 8 inch.....	. 40
1 square, carpenter's, polished steel, No. 100.....	1. 50
1 square, try, rosewood stock, brass-faced, steel blade, 8 inch.....	. 40
1 sliding T-bevel, rosewood stock, brass-faced, 10 inch.....	. 45
1 gauge, marking, boxwood, brass thumbscrew, shoe, and face, No. 165.....	. 45
1 rule, Stanley (or equal), boxwood, double brass bound, 1 inch wide, 4 fold.....	. 35
1 scraper, cabinet, steel, 3 by 5 inch.....	. 14
1 pair dividers, wing, 10 inch.....	. 30
1 hand screw, beechwood, 12 inch—1¾ by 1¼ inch.....	. 60
1 saw, hand, rip, H. Disston & Sons (or equal), No. 12, 7 points, 26 inch....	2. 25
1 saw, hand, crosscut, H. Disston & Sons (or equal), No. 12, 10 points, 24 inch .	2. 00
1 saw back, H. Disston & Sons (or equal), No. 12, 14 points.....	1. 25
1 hammer, nail, Hammond's (or equal), adz eye, bell pole, No. 11½.....	. 70
1 mallet, round, hickory, No. 4.....	. 15
1 file, cabinet, open cut, ½ round, 10 inch.....	. 30
1 duster, bench, 10-inch block.....	. 60
Total.....	61. 31

Cost of class tools for advanced work.

1 plane, smooth, Stanley (or equal), Bedrock, No. 604, 9 inch.....	\$2. 00
1 plane, jointer, Stanley (or equal), Bedrock, No. 607, 22 inch.....	2. 60
1 plane, rabbet and fillister, Stanley (or equal), No. 78.....	1. 10
1 plane, plow, Stanley (or equal), Universal, No. 55.....	12. 00
1 scraper, veneer, Stanley (or equal), Adjustable, 3-inch cutter, No. 12.....	1. 90
1 ax, hand, 4-inch cut.....	. 90
1 set chisels, ⅜ inch to 2 inch, inclusive, 12 chisels, Buck Bros. (or equal), socket firmer, No. 35, leather tip handles.....	5. 90
1 stone, oil, 1 by 2 by 8 inch, Arkansas unmounted (or equal).....	1. 00
1 stone, oil, 6-inch slip.....	. 30
1 set bits, auger, Genuine Russell Jennings (or equal), ⅜ inch to 1⅝ inch, inclusive, 13 bits, double spur.....	4. 75
1 bit, expansive, Steers (or equal), No. 1, 2 cutters, ⅞ to 3 inch.....	1. 75
2 countersinks, rose pattern, for wood, at 14 cents each.....	. 28
2 nail sets, Starretts (or equal), knurled, medium, at 12 cents each.....	. 24

2 screw driver bits for brace, round blade, at 15 cents each.....	\$0.30
1 gauge, mortise, rosewood, plated head, improved screw slide.....	.65
1 can, oil, straight spout, copperized steel, 1 pint.....	.25
1 burnisher, apple handle, 4-inch blade.....	.45
1 saw, frame, turning, 18 inch.....	1.00
1 saw, compass, H. Disston & Sons (or equal), 16 inch.....	.45
1 saw set, Tainter's (or equal), positive.....	.75
1 saw clamp, japanned, 9-inch jaws, No. 3.....	.60
1 glue pot, double, enameled inside, 4 pint.....	1.40
1 file, mill, 10 inch.....	.25
6 files, saw, slim taper, 4½ inch, at 12½ cents each.....	.75
Total.....	41.75
Total cost.....	102.86

SPLIT-LOG DRAG.

(See fig. 26.)

Materials.—A dry log, 7 or 8 feet long and 10 or 12 inches in diameter; 3 sticks, 3 feet long and 3 inches in diameter; a piece of 2 by 4, 3 feet long; a light chain; 3 boards, 8 feet long, 8 inches wide.

Directions.—Split the log carefully down the middle. If one side should be better than the other, use the better side for the front.

Bore a 2-inch hole in the front log, 4 inches from the end that will follow the middle of the road; another hole 22 inches from the opposite end of the log, and one halfway between these two.

In the back log bore a 2-inch hole 20 inches from the end of the log that is to be in the middle of the road; another 6 inches from the opposite end, and a third midway between these, being very careful that all holes are bored plumb.

The logs are to be held apart by stakes tapered at both ends and driven firmly into the holes and held there by wedges. The logs should be about 30 inches apart.

Set the 2 by 4 for a brace at the ditch end of the drag, from the cross stake in the back log to the end of the front log, about an inch from the bottom.

A strip of iron 3½ feet long, 4 inches wide, and ¼ inch thick may be used as a blade and bolted to the ditch end of the front log, using bolts with flat heads and the holes for them countersunk. This blade is not necessary, but adds much to the effectiveness of the drag.

A platform of boards cleated together, leaving spaces of at least an inch between them, should be placed on the stakes.

HOW TO USE A DRAG.

Hitch the team so that the earth will move freely along the faces of the logs when the drag is in motion.

1. SETTING POSTS.

Posts should be set $2\frac{1}{2}$ feet in the ground and tamped solidly into place. For barbed wire fences they should be $16\frac{1}{2}$ feet apart. For inclosing large fields or pastures they are frequently set at twice that distance. For board or rail fences the distances between posts is controlled by the length of material used, but should never exceed 8 feet. Always set posts in a straight line and when practicable conforming to the cardinal points of the compass. Corner posts should be larger and longer than other posts and should be set $3\frac{1}{2}$ or 4 feet in the ground and braced from two sides. Posts in low places should be set at least 3 feet in the ground.

2. BUILDING FENCE.

Cedar posts should always be used when obtainable. Posts of other material should be treated with creosote or coal tar or should be charred before being set. In building barbed wire fences the wire should be stretched very tight, using a wagon for the stretching. A wire stretcher does very well for small fields, but is not so satisfactory for large ones. If the fence is of boards, they should be nailed to the posts with three nails in each post. Care should be taken to have boards or wires equal distances apart.

3. PLANTING TREES.

The land where the trees are to be planted should first be carefully plowed and leveled as for any other crop. The hole for the tree should be dug wide and deep. The harder the soil the larger the hole should be, because in such case the tree must start in the loose dirt that is cut up in the bottom or thrown into the hole. In a loose, deep soil the hole need not be larger than the spread of the roots.

Trees should be set an inch or two deeper than they stood before transplanting. The roots that are broken should be trimmed off at the ends and should be spread out in planting to their normal position. If there are extra long roots, they should be cut back to correspond to the rest. The soil must be put in firmly about the roots, especially under the fork, so that there may be no air spaces left. This can best be done with the fingers, moving the tree up and down a little at the same time. The earth should be stamped down once or twice as the hole is being filled. The hole should be a little more than full of earth, so that the surface water can be carried off, being specially careful not to leave holes near the tree where the water will settle. Stamp the earth thoroughly before leaving it, to hold the moisture and enable the tree to stand up against the winds.

A good plan to conserve moisture in planting a tree is to put a mulch of straw or manure around it.

The top of the tree should be shortened at the time of planting a little more than the root has been cut off, but should not be trimmed back too closely.

Plant all orchard trees in straight rows, but ornamental shade trees should be set out with the general plan of the grounds they are to ornament in mind, and usually should not be in such rows.

4, 5, 6. OILING AND MENDING HARNESS.

Before a harness is oiled it should be thoroughly cleaned of all foreign substance by scraping off accumulated dirt with a dull knife and then by washing with castile soap or regular harness soap. It should then be hung up to dry, but not in the sunlight. When it is thoroughly dry, it should be inspected to find where it needs mending. Every break and every place that shows any sign of giving way should be repaired. When the repairing is in the line of sewing, this should be done with a waxed thread, but when this is impossible, mending may be done by using copper rivets, which are readily obtainable at every general or hardware store. In using these rivets, care should be taken to punch in the leather as large a hole as may be necessary to receive the rivet, and no larger.

After the mending has been done, the harness should be gone over thoroughly with good harness oil, care being taken not to apply more than the leather will readily absorb. The harness should then be hung to dry in the shade, and, after the oil has disappeared, should be gone over with a cloth. In hot climates a harness soap is better than an oil.

7. CARING FOR FARM AND OTHER TOOLS.

Tools should be thoroughly cleaned after using and should be kept oiled. This is especially true when a tool like a plow is put away and left for some time without use. Unless it is thoroughly oiled it will be sure to rust. All steel tools are better for a coat of oil, but this is essential to every bright tool with a cutting edge.

All edge tools should be kept sharp. Stopping work to sharpen a dull tool is nearly always economy. Almost the first thing a boy should learn in the handling of edge tools is how to keep them sharp and in good condition for work.

8. PRUNING.

Pruning is removing certain parts of plants or trees to make them better and more productive, or to keep them in manageable shape and to make them easier to care for.

A fruit tree should be pruned moderately every year, while an ornamental tree should be pruned as often as is necessary to remove dead or superfluous branches and to keep it within the limit designed for it.

9. PROTECTING TREES.

Trees may be protected from vermin by putting around the lower part of the trunk of the tree a wire screen or by wrapping with tar paper. If such protection is used the trees must be watched carefully to see that these protections do not harbor other enemies of the trees.

Insect enemies are destroyed by killing them directly by some poisonous application or by poisoning their food. For the fungus enemies of trees some application must be made that will destroy the fungus.

Applications for both insects and fungus are usually made in water and sprayed onto the trees. This spraying must be done with materials which will kill the enemy without injuring the plant or the fruit, and the work must be thoroughly done before either pest has obtained a foothold. It is best to spray fruit trees every season whether a pest has appeared or not.

10. PUTTING HANDLES IN TOOLS.

In all tools having eyes, such as hammers, hatchets, axes, grub hoes, or picks, the handle should be fitted neatly to the eye, it being larger at the lower or outer end. The handle is usually larger than the eye of the tool for which it is intended and should be shaped down until it fits as close as possible. The handle should be driven in and split lengthwise of the eye and a wedge driven in tight and cut off close to the handle; then other wedges should be driven in crosswise, after which the handle should be dressed off flush with the tool.

In putting handles into shovels, hayforks, and all tools having sockets, all the old wood should be removed, rivets taken out and the handle fitted to the socket as neatly as possible. Then drive it in tight and replace the rivets. Care must be taken not to drive the handle too tight as there is danger of splitting the ferrule.

In all tools having a piece of steel inserted in the wood to hold the handle in place, a hole should be bored in the end of the handle about $\frac{1}{16}$ inch smaller than the part that is to be inserted. A ferrule is then put onto the end of the handle and the handle is driven tightly onto the tool.

11. NAILING ON HORSESHOES.

It is not expected that every boy shall become an expert horse-shoer, for horseshoeing is a trade that ought to have several years of apprenticeship. It is necessary, however, that every boy who lives on a farm should know how to nail on a shoe that has accidentally been pulled off. This usually comes from the horse's overreaching, and, if the hoof be not broken, the shoe can be nailed on without much difficulty.

Be sure that the shoe is placed straight on the foot; then start the driving with one of the front nails. As small a nail should be used as will hold the shoe. Drive the nail so that it will follow the wall of the hoof, coming out through the wall with sufficient length to twist off and clinch. In clinching the nails, do not strike hard blows, but rather a number of easy ones, so that the horse's foot may not be hurt. Do not use a rasp. Always be sure that the nail comes out through the wall of the hoof.

12. SHARPENING PLOWS.

Heat the plowshare to a cherry red; then hammer it out on the underside to a sharp edge and in an even line. It should then be trued up with the hammer and filed on the top side to a sharp bevel edge. After it is sharpened it should be heated to a dull red and then held in water until cool.

13. MIXING MORTAR.

In making common lime mortar the first care is the selection of the lime, which should be free from cinders, clinkers, and other impurities, and should be chiefly in hard lumps. It should slake freely in water, forming a fine smooth paste and should dissolve entirely in soft water when this is added in sufficient quantity.

When prepared for use lime should be slaked in a box and screened into a pit made for the purpose. The slaking should be done some days before the lime is to be used in order that it may be complete. After being screened into the pit it may be covered with sand to keep out the air, and the preparation will keep almost indefinitely. It can be taken from this pit at any time and mixed with the required amount of sand, according to the purpose for which the mortar is to be used. From $2\frac{1}{2}$ to 3 parts of sand to 1 part of lime paste is the most common proportion.

14. LAYING CEMENT WALKS.

The use of Portland cement in concrete construction has become so common that its use for ordinary purposes should be known to everyone, and knowledge of handling it is a resource that every Indian boy should possess before he leaves school. The fundamental principles of the use of cement in making mortar or concrete are very simple and easily learned. Skill in its use comes only from practice and experience.

Cement mortar for brick or stone work is made in the following proportion: One barrel (380 pounds net) Portland cement, 4 barrels sand, and 2 pails of lime putty.

Concrete is best made from a mixture of broken stone, clean coarse sand, and Portland cement, in such proportion that the

cement will just a little more than fill the voids between the grains of sand.

The coarse material that is used in making concrete is frequently called the aggregate, and any hard broken stone is suited to this purpose. Gravel is frequently used, but is not as satisfactory as the broken stone because of its roundness and smoothness.

In making all concrete mixtures all parts should be carefully measured. Careful measurement is absolutely necessary to success. A wheelbarrow makes a very convenient measure.

The concrete should be mixed as near the place where it will be used as is practicable, so that no time will be lost in getting it into place. For small jobs only a small quantity should be mixed at one time, as concrete can not be used after it begins to harden.

Mixing is best done as follows: Measure the sand and spread it to an even depth on a water-tight platform; measure the cement and spread it on the top of the sand and then mix thoroughly until the mixture shows a uniform color; then the measure of stone, thoroughly wet, should be placed on top and mixed with the sand and cement in similar manner; then sufficient water should be added to make a mixture just too soft to bear a man's weight when it is put in place. Add the water very carefully so that the mixture shall not be too thin.

Mixtures are medium, ordinary, and lean, according to the amount of cement contained in each, which is governed by the purpose for which the mixture is to be used.

A rich mixture for tanks and other water-tight work consists of 1 part cement, 2 parts sand, and 4 parts broken stone. A medium mixture for foundations, floors, sidewalks, or sewers contain 1 part cement, $2\frac{1}{2}$ parts sand, and 5 parts broken stone. For heavy walls, piers, or abutments, an ordinary mixture of 1 part cement, 3 parts sand, and 6 parts broken stone is used. For large foundations or other work where the concrete is subjected to continuous plan strain, a lean mixture consisting of 1 part cement, 4 parts sand, and 8 parts broken stone is satisfactory.

Excavate to the grade decided upon and about 3 inches wider than the proposed walk and fill with foundation material of broken stone or cinders to within 4 inches of the proposed finished surface, wetting the foundation well and tamping it in so that it will be even and firm but porous. If the soil is good and firm, the foundation may be dispensed with, merely spreading a layer of about 1 inch of sand over the bottom of the excavation, which would then not be more than 5 inches.

After the foundation has been laid, place 2 by 4's, toenailing the 2 by 4's to the stakes. Care should be taken that the scantling be set in straight lines and that these lines be kept the same distance

apart. Fill the frame with concrete, the mixture being 1 part cement, 2 parts clean, coarse sand, and 4 to 6 parts broken stone, which should be tamped in until the water begins to show on top.

The finishing coat should be 1 inch thick and of 1 part cement to $1\frac{1}{2}$ or 2 parts good, clean, coarse sand. This should be spread before the concrete base has set and should be smoothed off with a straight-edge, flush with the surface of the scantling frames. Smooth with a wooden plate and cut into square blocks with groover. In warm climates where the concrete is likely to expand, a seven-eighths-inch board should be set in across the walk about every 50 or 60 feet to the depth of the frame. Fill into this, and before the concrete has firmly set, but when it will stand, the board should be removed and the space filled with dry sand.

Cover the completed walk with sand or other convenient material to keep it from drying too rapidly and to protect it from dust and the sun.

15. LAYING STONE WALL.

No wall should be less than 18 inches thick. The largest stones should be in the foundation course, and as many stones as possible that go through the wall should be used. Fragments of stones may be used for filling in.

No joint between two stones should come over a joint between other two stones, but the stone should overlap from 1 to $1\frac{1}{2}$ times the depth of the course.

Stones should be laid in the wall as they lay in the quarry.

All dry and coarse stones should be moistened before they are laid in order that the stone may not absorb the moisture in the mortar, and thus dry it too fast. Every part of the joint of all the spaces between the stones should be filled with mortar, but these spaces should be made as small as possible. After the mixture is laid the joints in the face should be cleaned out and refilled with cement mortar. The joints should be thoroughly cleaned to the depth of at least half an inch, but an inch is much better. A mixture of 1 part cement, 1 of sand is, perhaps, most commonly used.

16. HANGING DOORS.

The door is held up against the jambs and marked around with a pencil. It should then be cut to these lines, being made about one-eighth inch narrower and three-eighths inch shorter than the opening. The upper hinge should be about 6 inches from the top and the lower one about 10 inches from the floor. The thickness of the plinth or the casing should be subtracted from the total width of the hinge, and the balance divided by two will give the distance the hinge is to be set back from the face side of the door. In all cases the hinge

should be wide enough to reach across two-thirds of the thickness of the door. The jamb should be at least $1\frac{1}{2}$ inches thick or else be backed up solidly, so as to give the hinge screws a good hold; $1\frac{1}{4}$ -inch screws should be used for common size doors. Heavy doors should have three hinges. The mortise for the hinge of the door should bevel slightly toward the front, so that the hinge will not strike the jamb.

17. SETTING LOCKS.

Rim locks are those that are simply screwed onto the face of the door, while mortise locks are those that are set into the door itself. In setting the former, the lock is held in position and marked for the keyhole, knob-bar hole, and screw holes. The first two are cut and the last are bored, and the lock screwed into place. The escutcheon and knob plates are put on, and the keeper is then put onto the jamb. For a mortise lock, the lock is set in the door with a mortise just large enough to admit it, the face plate of the lock being set flush with the face of the edge of the door. The places for the holes for the knob bar and keyhole should then be marked and cut, the lock set and fastened in, the knob-plates and escutcheon set, and the knobs adjusted. The keeper is then mortised into its proper place flush with the face of the edge of the jamb.

18. PAINTING AND GLAZING.

Composition of paints: Paint is composed of two ingredients, the pigment, which gives body and color, and the fluid in which this color is dissolved or suspended. If the painting is for protective purposes, the fluid is oil; if for decoration only, it may be water.

The best white pigment is pure white lead, while the most common black pigment is lamp black. Pigments that will give the different colors and shades of color may be used as desired.

The oil most commonly used by painters is linseed oil, the drying qualities of which are improved by boiling, when it is commonly known as boiled oil. Its quality can be determined by looking through a small bottle filled with it. Good, fresh oil should be clear in appearance and have very little odor; poor oil is not clear and has a strong and rancid odor. If paint is too thick, good oil should be used to thin it. Driers are frequently used in order to cause the paint to dry more readily; in fact, some colors will not dry at all without their use.

A varnish is a solution of a gum or resin in turpentine, linseed oil, or some like fluid, and is used to produce a hard and shining surface. A cheap varnish suitable for ordinary work can be made as follows: Add $2\frac{1}{2}$ pints of turpentine to 3 pounds of dried resin, shake well and allow to stand for a day or two, shaking occasionally. Add 5 quarts of boiled oil; shake thoroughly and allow to stand in a warm room until clear; then pour off the clear portion and it is ready for use.

Before beginning to paint, the surface to be painted should be thoroughly cleaned, and all spots and dust removed. The knots should be covered with shellac, which can be easily obtained, and all nail holes, bad joints, and cracks should be filled with putty.

New woodwork should receive at least three coats of paint. The first coat is called the priming and should be thin and readily absorbed into the wood. The stopping up of the nail holes, etc., should be done after the priming is applied.

The intermediate coats should then be applied as evenly as possible, the second coat being laid at right angles to the grain of the wood, while the third coat should follow the grain, care being taken to leave no brush marks. The final coat should give the desired tint.

In repainting old work, it should be carefully cleaned with a knife and then gone over with powdered pumice stone and water, rubbing the greasy parts with lime.

Whitewash is used for common walls and ceilings where, for sanitary reasons, a frequent application is better than a coat which would last longer. It is made from pure white lime, mixed with water and is improved by adding a pound of pure tallow to every bushel of lime. Lime for whitewash should be slaked with boiling water and, when slaking is complete, the lime can be dissolved in water and applied with a common whitewash brush. Whitewash is improved by adding 2 pounds of zinc sulphate and 1 pound of common salt to every half bushel of lime used.

Whitewash can be tinted to any color desired by the use of tints, which are readily procured.

In setting a pane of glass to replace a broken one, care should be taken to remove all pieces of the old putty, which can be done with a knife or with a hot iron. When the glass has been fitted, a thin layer of putty should be put on the frame and the pane of glass pressed into place against this. This prevents the glass from touching the wood and renders it less likely to be broken. The putty should then be applied smoothly with a putty knife. Glazier's points should be used to hold the glass in place until the putty is applied.

Putty can be made from whiting and linseed oil, but can be more readily bought already prepared.

19, 20. BUILDING ROADS.

The first and most essential feature in road building is to secure good drainage, since water is the agent which does most damage. The road should be shaped like a roof, with the highest part in the middle and slopping evenly in both directions. On a hill side this may not be possible and the road will have to have only one slope, but generally speaking, a roof-shaped road is entirely practicable.

There are many kinds of road machines in use, all of which are more or less expensive, but the simplest apparatus for building and keeping a dirt road in good condition is the split-log dray (figure 33). This simple implement can be used very easily and effectively and can be made and owned by any farmer.

Wherever a draw or ditch crosses a road, a culvert of some sort must be put in. This may be made of stone, if such material is available, but is most commonly a plain box, made of planks. The size of this culvert is regulated entirely by the volume of water that is likely to pass through it during a rain storm. It should be set into the road so that its bottom will be on a level with the bottom of the ditch or drain that crosses the road, and the road above it should be kept fully up to grade.

21. GLUING.

Surfaces to be glued should be forced as closely as possible together and as little glue as possible should be used. The less the better. Glue should be applied hot and it is also well to warm the joint when practicable.

Good glue may be known by the way it breaks under the hammer. The more ragged the fracture the better the glue. The best method of making glue is to fill the inner vessel with small pieces of glue, cover them with water, and allow them to soak for a few hours. Glue should be applied hot and so thin that it will run off the brush almost like linseed oil.

22. SOLDERING.

Soldering is uniting two pieces of metal by means of another metal. The parts to be joined should be thoroughly cleaned by scraping or filing, and a flux must be used with the solder to join the two metals. This flux may be borax or resin, but muriatic acid is commonly used and is easy to handle. Resin is the best flux for tin; muriatic acid for zinc and galvanized iron; borax for iron and steel. The acid is kept in a small bottle with a piece of iron wire through the cork, dipping into the fluid, so that a drop may be applied to the surface of the metal to be soldered when desired.

The soldering iron must be kept tinned or it will not spread the solder. A few small scraps of tin are mixed with some resin in a hollow place in a brick or some similar place, and the hot iron is rubbed into this mixture until the tin has melted and adhered to the iron through the agency of the resin. A good-sized iron should always be used.

When the surfaces to be brought together are prepared, the soldering iron should be heated to a dull red and should then be rubbed clean on a piece of rag and applied to the solder in such a way that

the melted solder will cover the place to be mended. The solder should be then rubbed smooth from the joint with the iron, care being taken that it be not too hot.

23. HARNESSING, HITCHING, AND UNHITCHING HORSES.

Always handle your horses gently. Always speak to them before you go into the stall. Do not throw the harness on them as they do not enjoy being hurt. Always be sure that all buckles are fastened and that the ends of the straps are put into the keepers. In hitching a horse or a team to a vehicle, the traces should be the last things fastened, the lines being taken down first, so that the animals are always under control.

In unhitching, exactly the reverse process is followed, the lines being the last part of the harness to be put up.

In unharnessing a team, the buckles should always be loosened on the left-hand side.

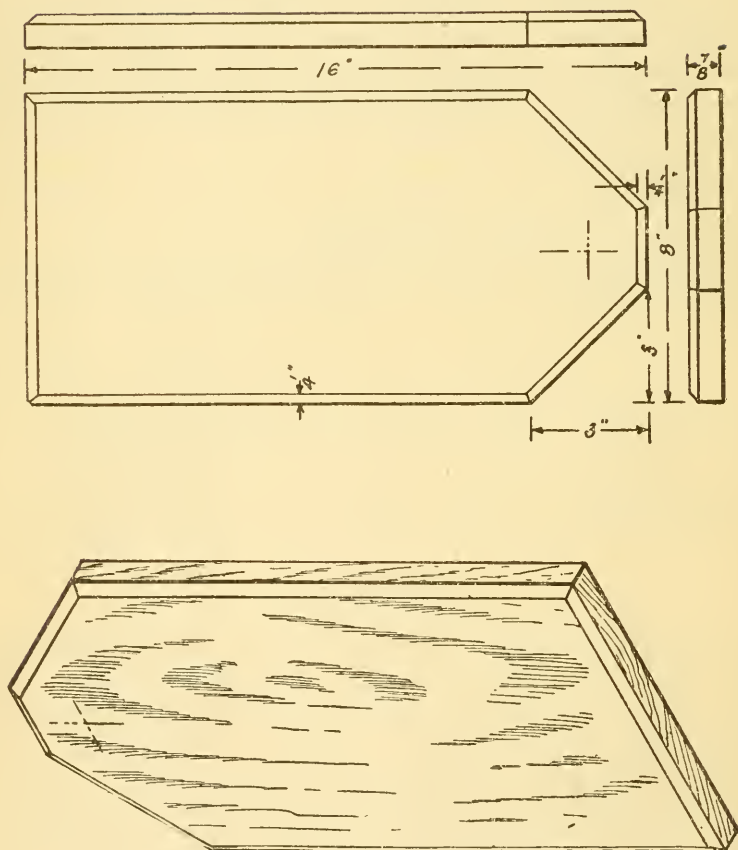

FIG. 1.—BREAD BOARD.

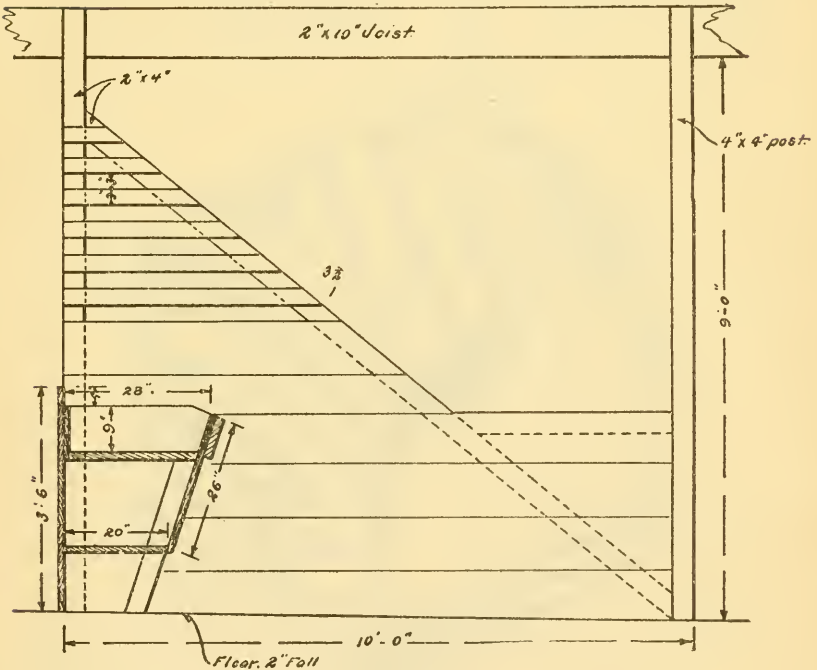
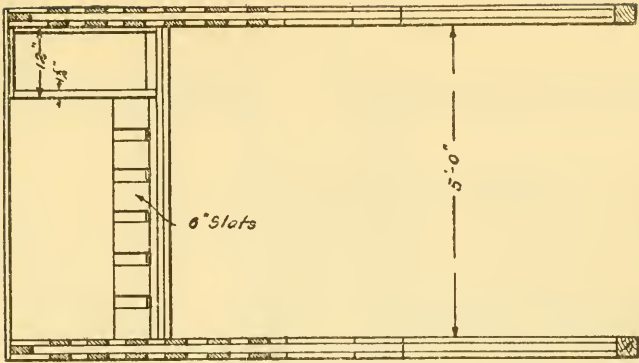

FIG. 2.—STALL, FEED BOX, AND MANGER.

BILL OF MATERIAL.

- 2 pieces yellow pine 4" x 4" x 10' 0".
- 2 pieces yellow pine 2" x 4" x 10' 0".
- 1 piece yellow pine 2" x 4" x 12' 0".
- 1 piece yellow pine 2" x 4" x 6' 6".
- 4½ pieces yellow pine 1" x 10" x 12' 0".

- 16 pieces yellow pine 1" x 10" x 10' 0".
- 1 piece yellow pine 1" x 6" x 12' 0".
- 1 piece yellow pine 2" x 12" x 10' 0".
- 3½ pieces yellow pine 1" x 9" x 12' 0".
- 1 piece yellow pine 2" x 8" x 5' 0".

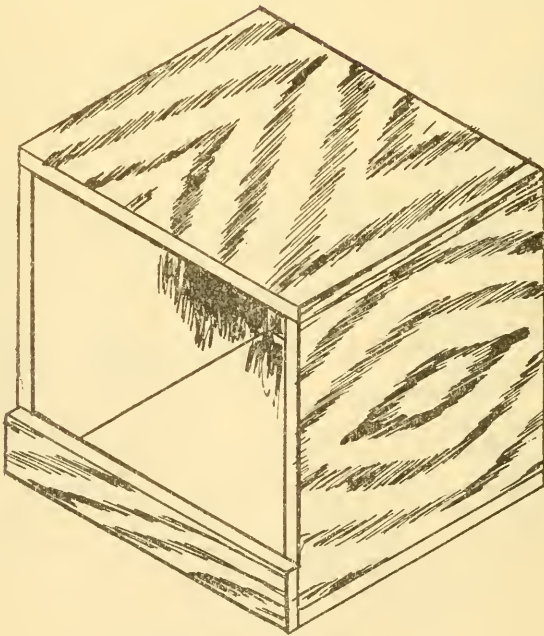
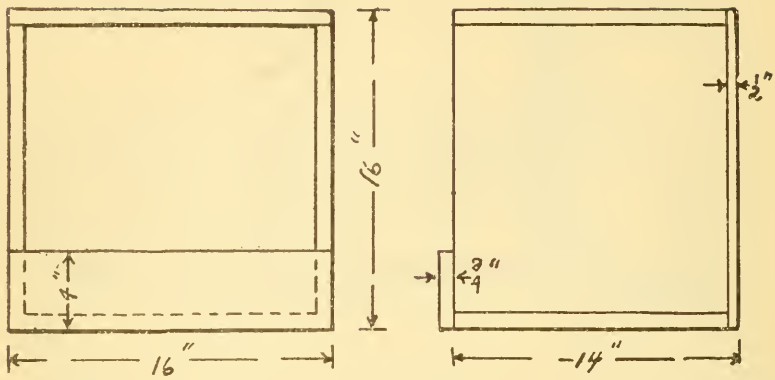

FIG. 3.—HEN'S NEST.

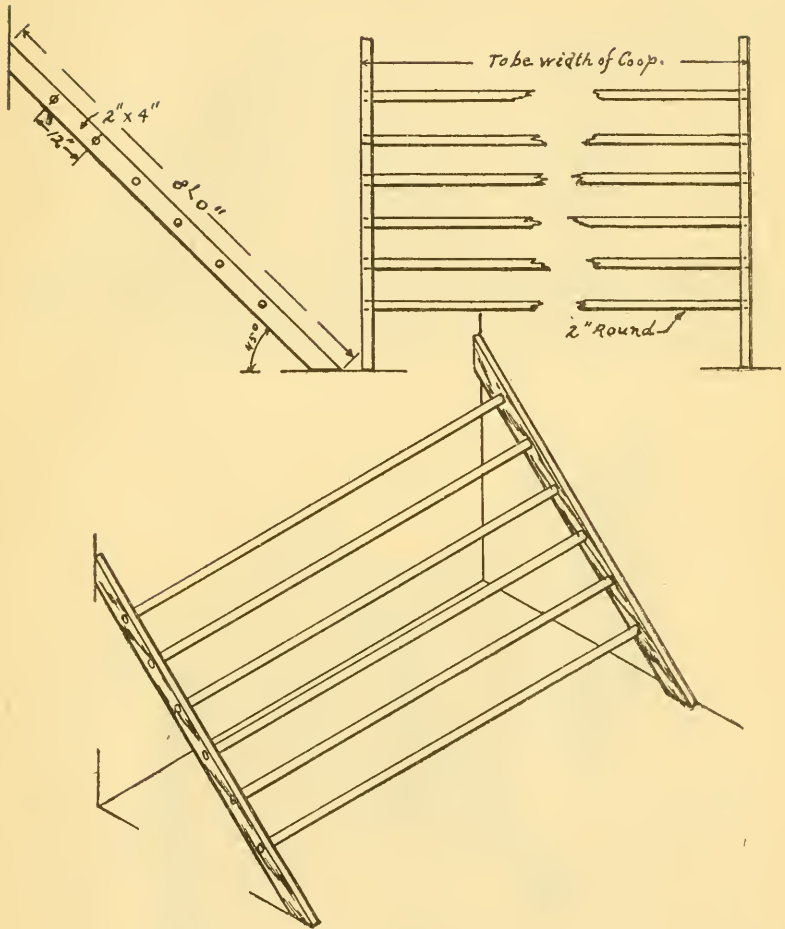

FIG. 4.—HENROOST.

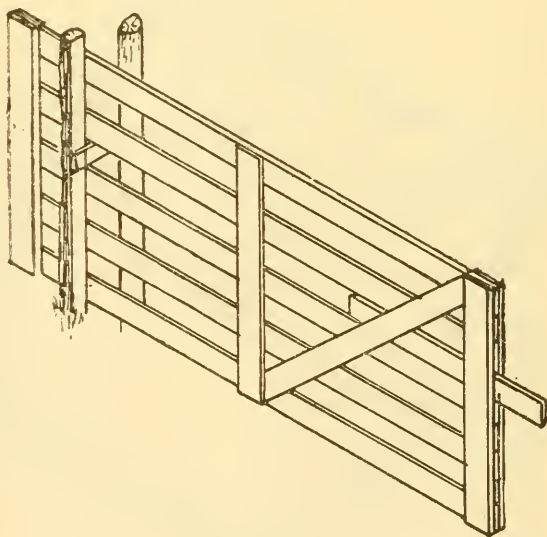
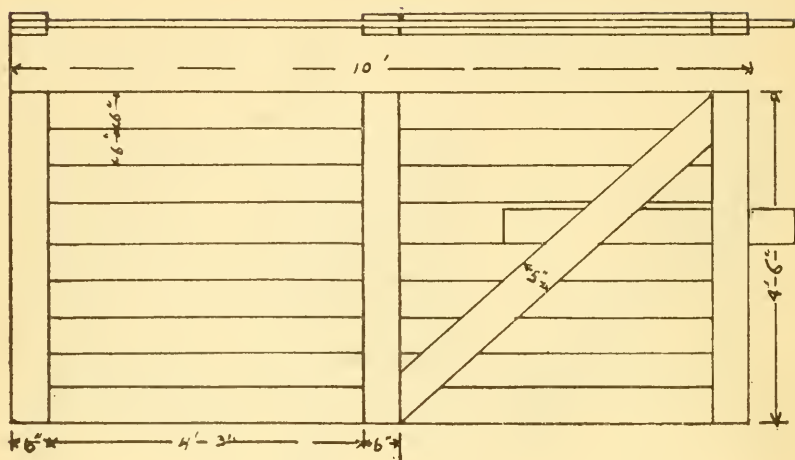

FIG. 5—GATE.

BILL OF MATERIAL.

- 5 pieces yellow pine 1" x 6" x 10' 0".
- 6 pieces yellow pine 1" x 6" x 4' 6".
- 2 pieces yellow pine 1" x 6" x 7' 0".

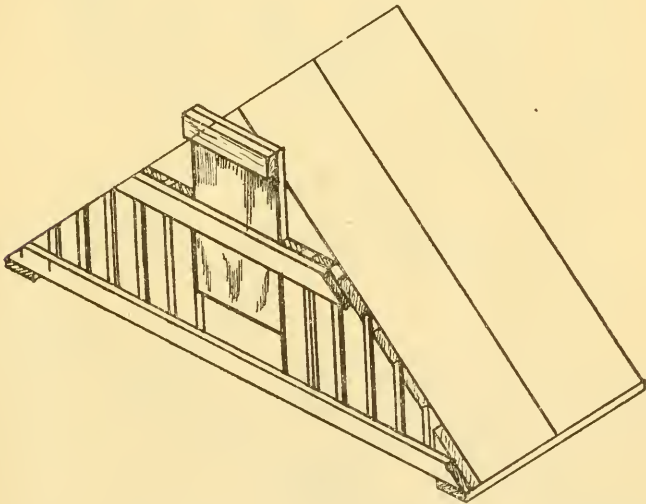
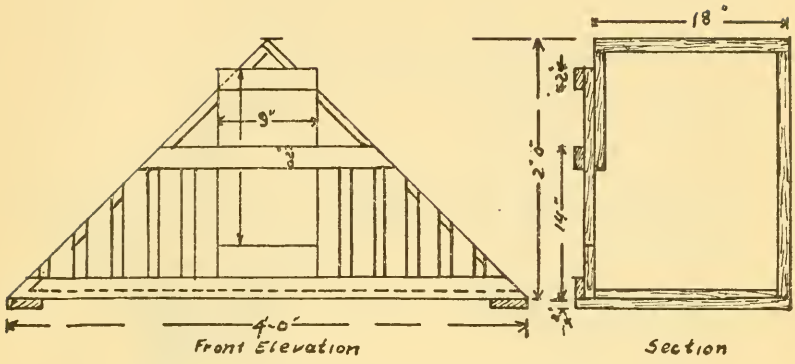

FIG. 6.—CHICKEN COOP.

BILL OF MATERIAL.

- 4 pieces yellow pine 1" x 10" x 3' 6"..... Top.
- 2 pieces yellow pine 1" x 10" x 4' 0"..... Bottom.
- 1 piece yellow pine 1" x 10" x 15"..... Door.
- 1 piece yellow pine 1" x 10" x 12' 0"..... Front and back.

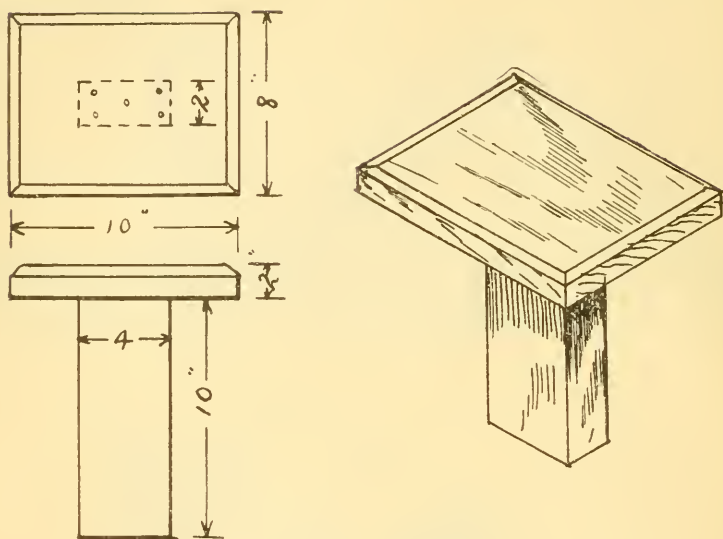

FIG. 7.—MILK STOOL.

BILL OF MATERIAL.

1 piece yellow pine $1\frac{1}{2}$ " x 8" x 10"..... Top.
 1 piece yellow pine 2" x 4" x 10"..... Leg.

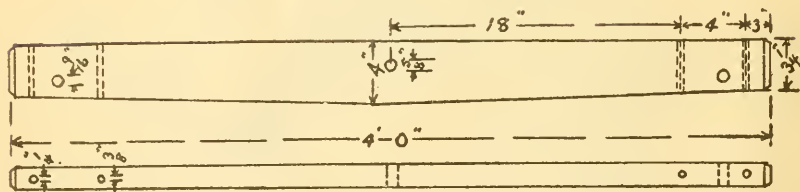

FIG 8.—EVENER.

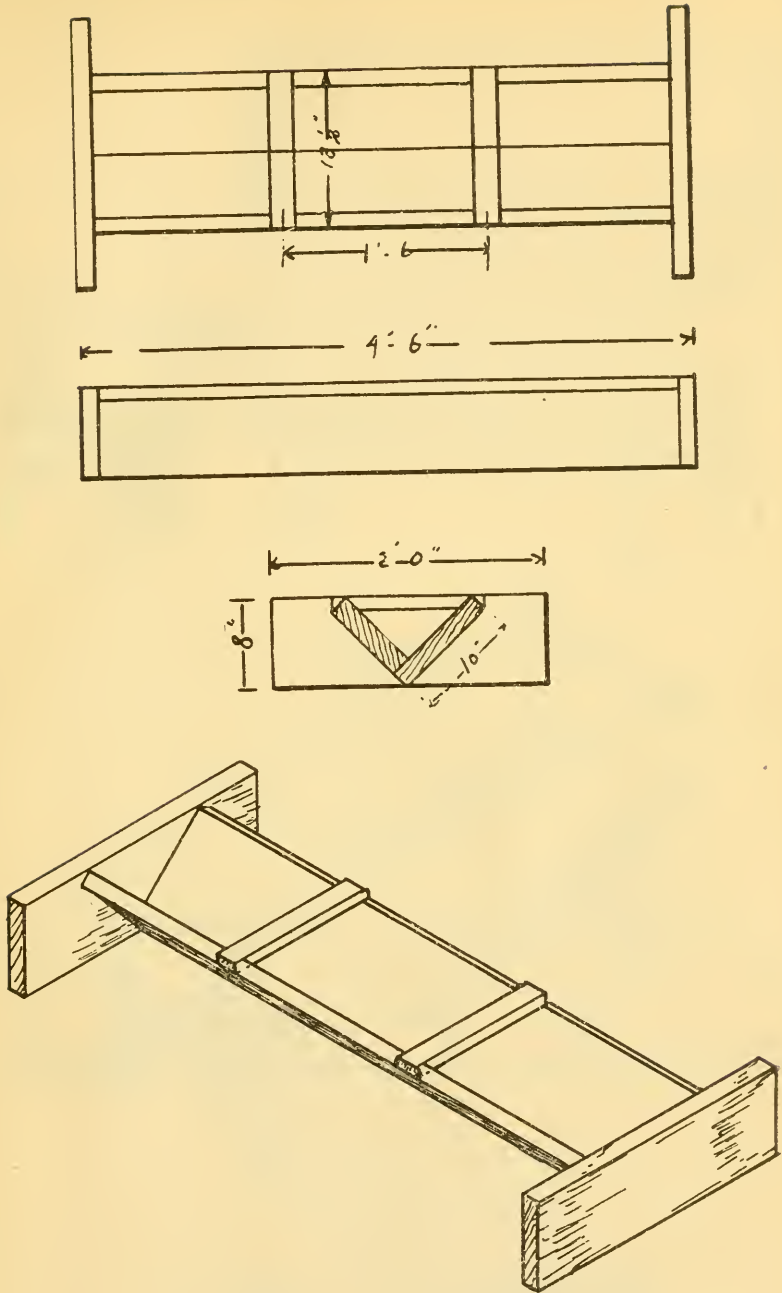

FIG. 9.—FEED TROUGH.

BILL OF MATERIAL.

- 2 pieces yellow pine $1\frac{1}{2}$ " x 10" x 4' 6"..... Sides.
- 2 pieces yellow pine $1\frac{1}{2}$ " x 8" x 2' 0"..... Ends.
- 2 pieces yellow pine 1" x 2" x 12"..... Crosspieces.

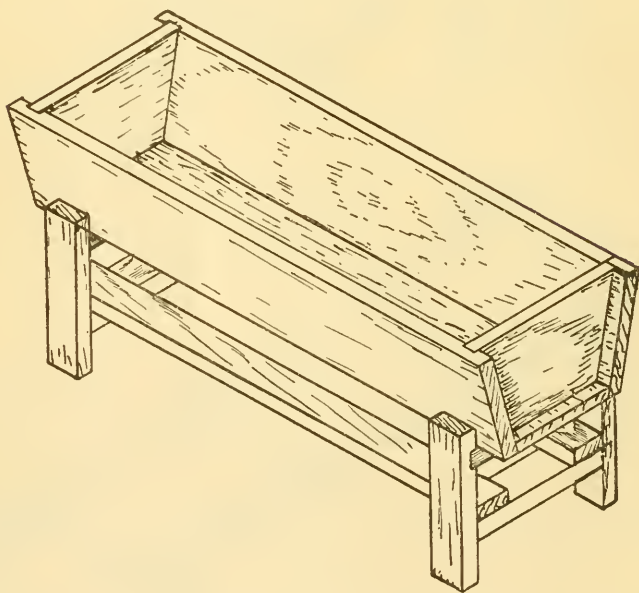
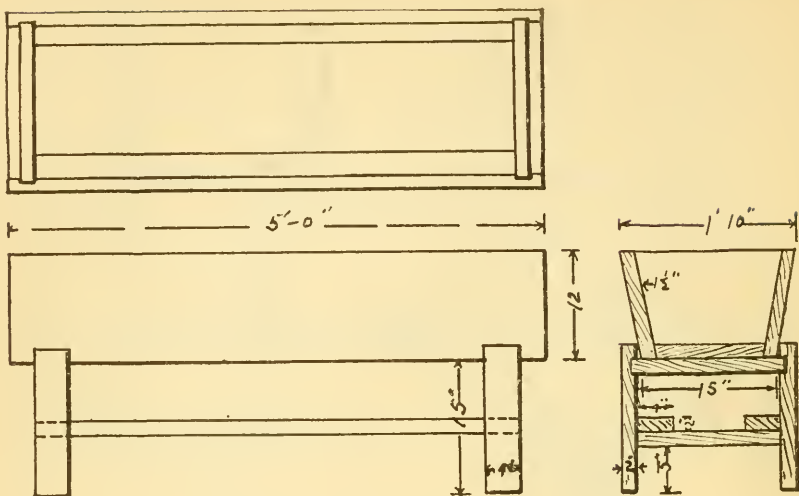

FIG. 10.—WATER TROUGH.

BILL OF MATERIAL.

- | | | | |
|----------------------|---|-------|-------------------|
| 3 pieces yellow pine | $1\frac{1}{2}'' \times 13'' \times 5' 0''$ | | Sides and bottom. |
| 2 pieces yellow pine | $1\frac{1}{2}'' \times 12'' \times 1' 10''$ | | Ends. |
| 2 pieces yellow pine | $2'' \times 4'' \times 4' 6''$ | | Crosspieces. |
| 6 pieces yellow pine | $2'' \times 4'' \times 1' 6''$ | | Legs and braces. |

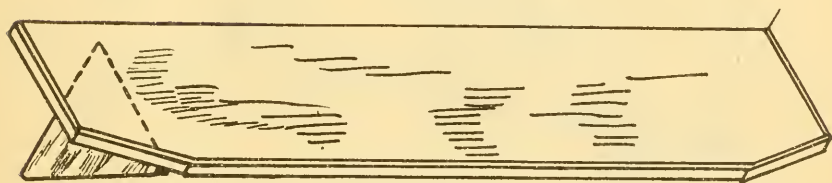
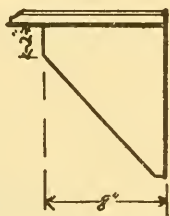
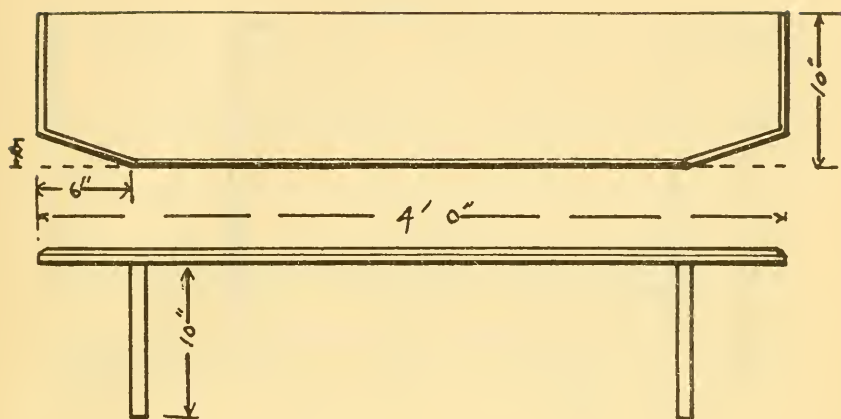

FIG. 11.—WALL SHELF.

BILL OF MATERIAL.

- 1 piece yellow pine 1" x 11" x 4' 2".
- 2 pieces yellow pine 1" x 9" x 11".

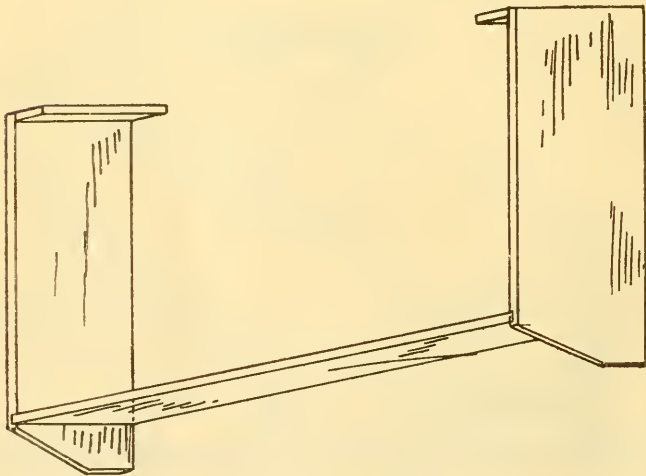
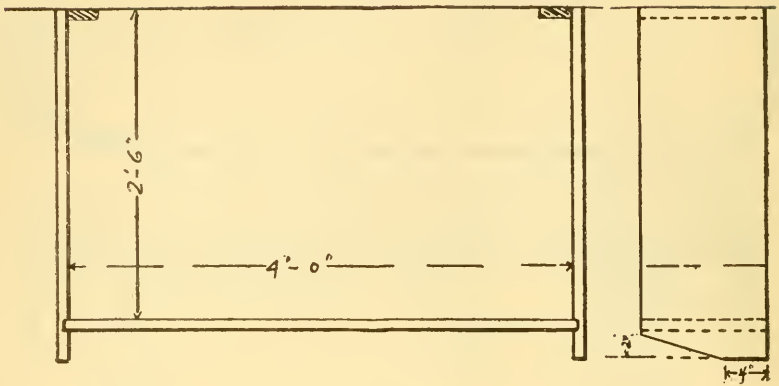

FIG. 12.—HANGING SHELF.

BILL OF MATERIAL.

- 1 piece yellow pine 1" x 12" x 4' 4".
- 2 pieces yellow pine 1" x 12" x 3' 0".
- 2 pieces yellow pine 1" x 3" x 12".

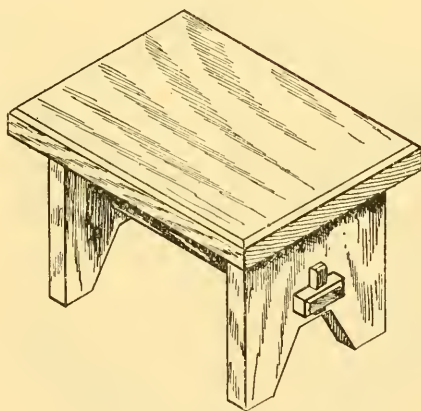
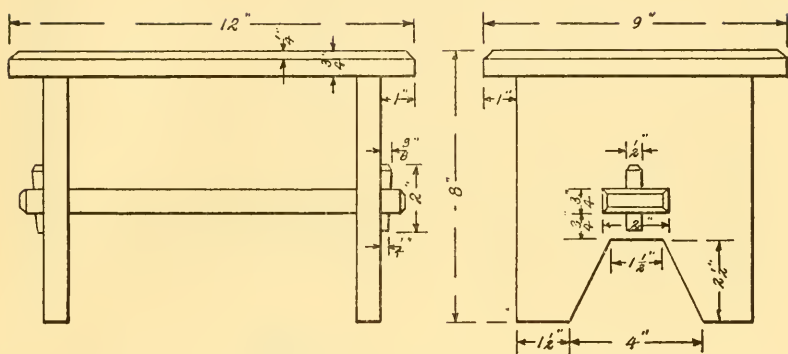

FIG. 13.—FOOTSTOOL.

BILL OF MATERIAL.

- 1 piece yellow pine 1" x 10" x 12 1/2" Top.
- 2 pieces yellow pine 1" x 10" x 9" Ends.
- 1 piece yellow pine 1" x 2" x 14" Crosspiece.

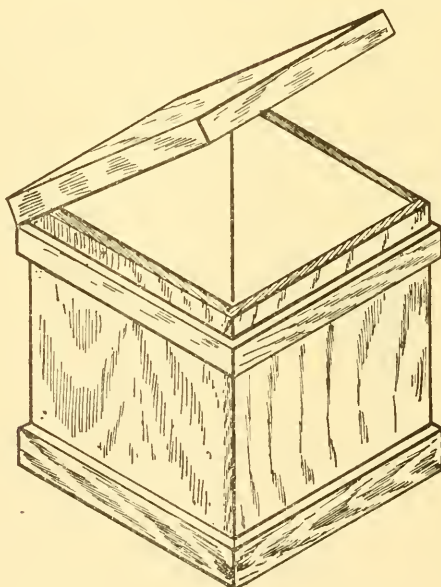
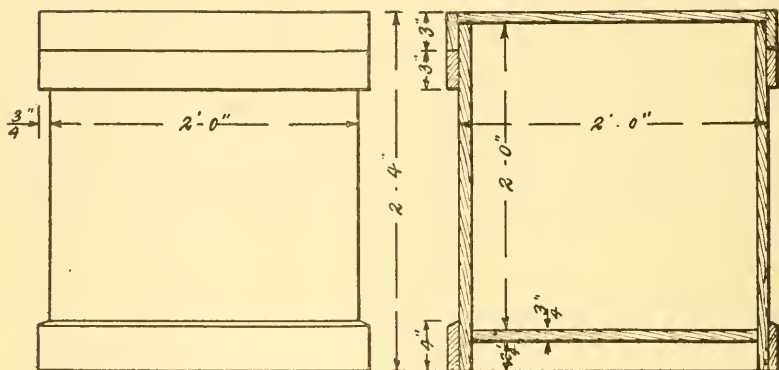

FIG. 14.—FLOUR BOX.

BILL OF MATERIAL.

- 12 pieces yellow pine 1" x 9" x 2' 6".
- 6 pieces yellow pine 1" x 9" x 2' 2".
- 4 pieces yellow pine 1" x 4 1/2" x 2' 4".
- 8 pieces yellow pine 1" x 3 1/2" x 2' 4".

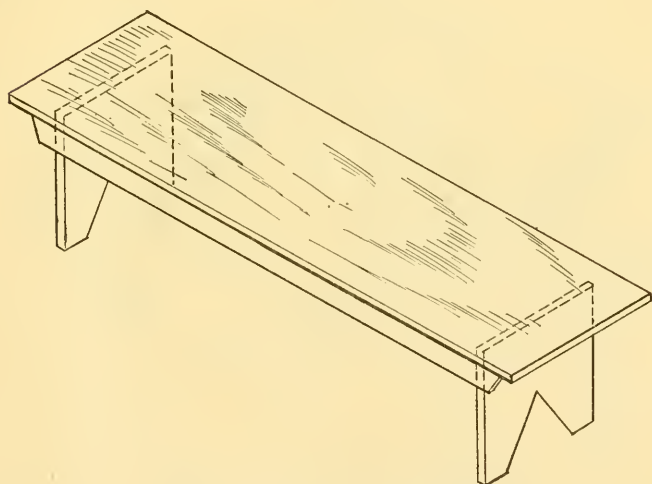
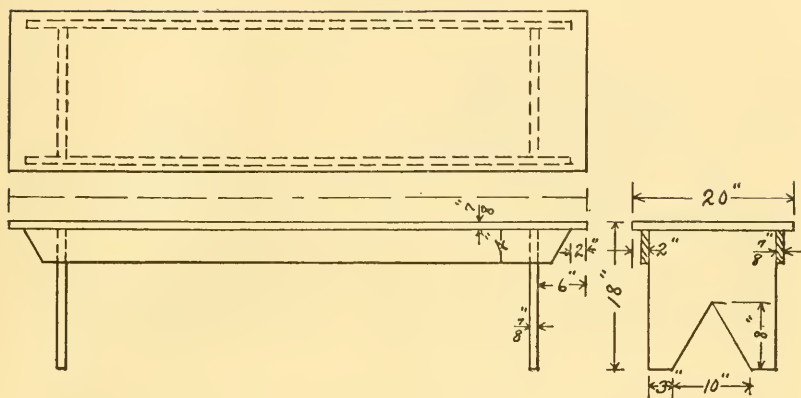

FIG. 15.—BENCH.

BILL OF MATERIAL.

- 2 pieces yellow pine 1" x 12" x 6' 2".
- 4 pieces yellow pine 1" x 10" x 1' 6".
- 2 pieces yellow pine 1" x 4 1/2" x 6' 0".

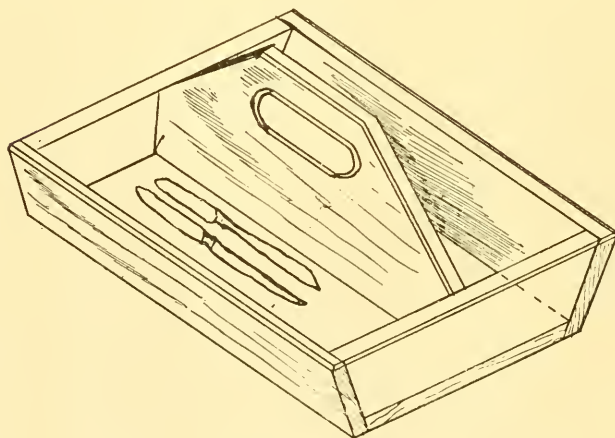
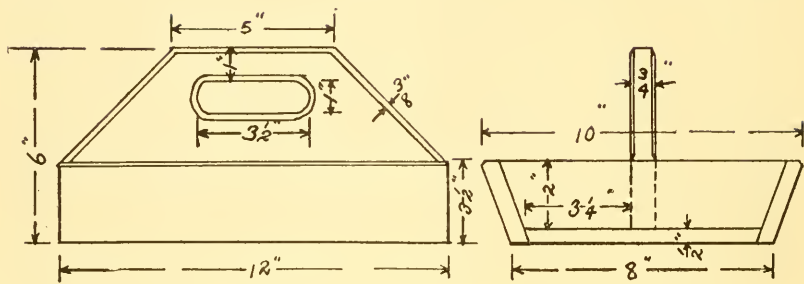

FIG. 16.—KNIFE BOX.

BILL OF MATERIAL.

- | | | |
|----------------------|---|------------|
| 1 piece yellow pine | $\frac{1}{2}$ " x 8" x 13" | Bottom. |
| 2 pieces yellow pine | $\frac{1}{2}$ " x 3" x 13" | Sides. |
| 2 pieces yellow pine | $\frac{1}{2}$ " x 3" x 10" | Ends. |
| 1 piece yellow pine | $\frac{3}{4}$ " x 6 $\frac{1}{2}$ " x 12" | Partition. |

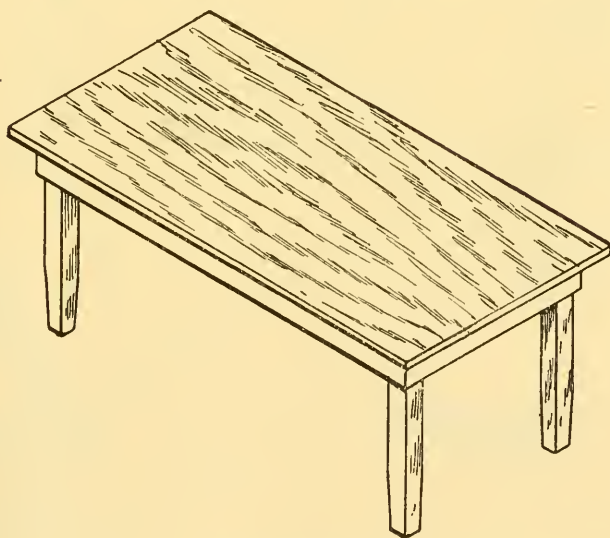
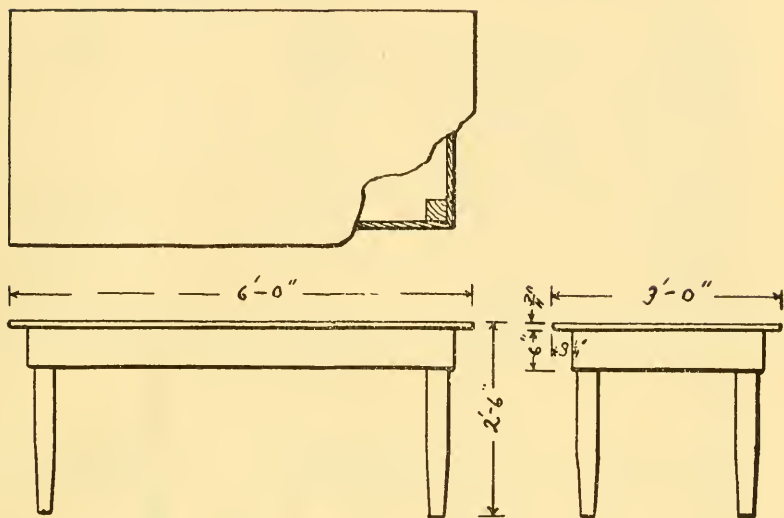
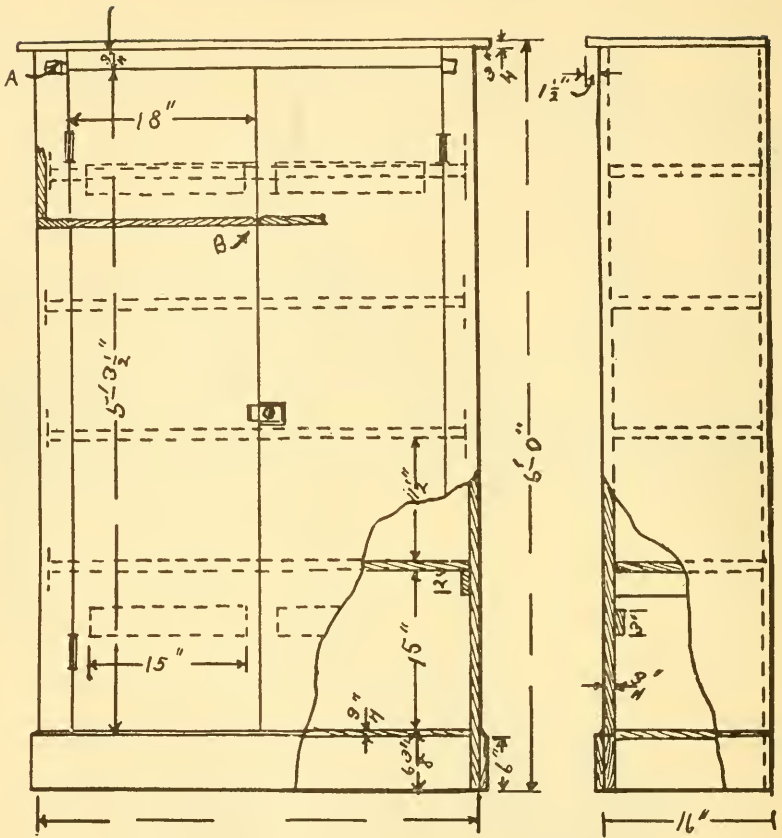

FIG. 17.—TABLE.

BILL OF MATERIAL.

- 4 pieces yellow pine 1" x 1 1/2" x 6' 0"..... Top.
- 4 pieces yellow pine 4" x 4" x 2' 6"..... Legs.
- 3 pieces yellow pine 1" x 6 1/2" x 6' 0"..... Side and end pieces.



Detail B.

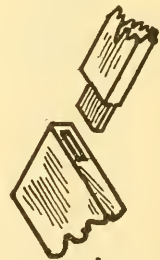

Detail A.

FIG. 18.—CUPBOARD

BILL OF MATERIAL.

- | | |
|--|--------------------------|
| 4 pieces yellow pine 1" x 10" x 5' 6" | Doors. |
| 4 pieces yellow pine 1" x 3 1/2" x 16" | Cleats on doors. |
| 4 pieces yellow pine 1" x 8" x 6' 0" | Sides. |
| 2 pieces yellow pine 1" x 10" x 4' 0" | Top. |
| 2 pieces yellow pine 1" x 8" x 3' 6" | Bottom. |
| 1 piece yellow pine 1" x 6 1/2" x 10' 6" | Base. |
| 2 pieces yellow pine 1" x 3" x 6' 10" | Front stiles. |
| 2 pieces yellow pine 1" x 2" x 8' 6" | Front rails. |
| 5 pieces yellow pine 1" x 10" x 6' 0" | Back and shelf supports. |
| 8 pieces yellow pine 1" x 8" x 3' 0" | Shelves. |
| 2 pair hinges. | |
| 1 cupboard catch. | |

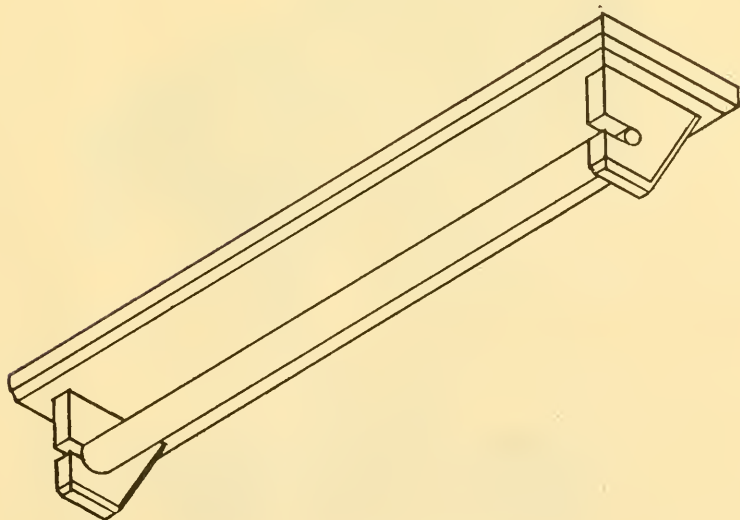
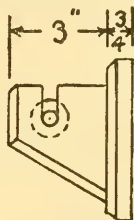
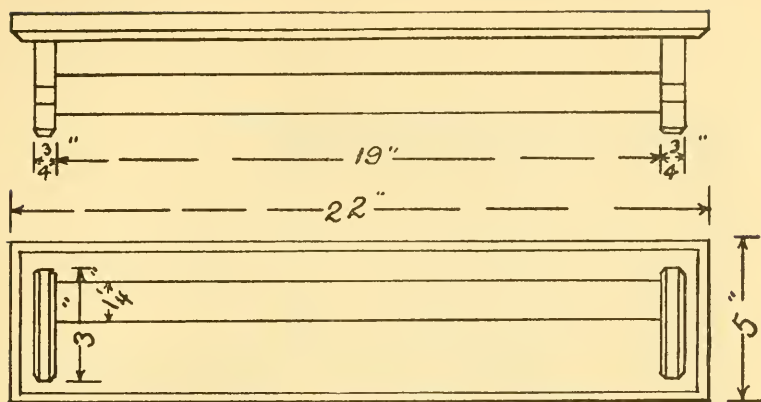

FIG. 19.—TOWEL ROLLER.

BILL OF MATERIAL.

- 1 piece yellow pine 1" x 6" x 2' 0"..... Back
- 2 pieces yellow pine 1" x 4" x 3 1/2"..... Bracket.
- 1 piece yellow pine 2" x 2" x 2' 0"..... Roller.

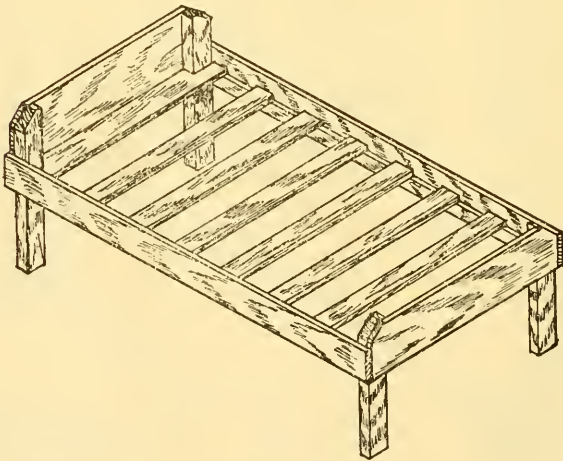
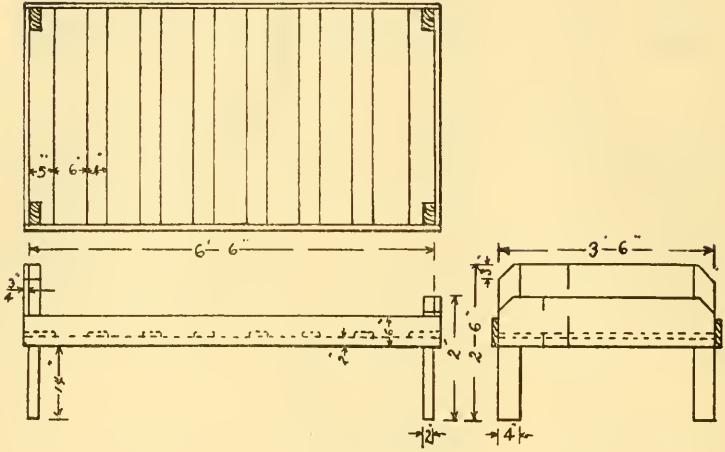

FIG. 20.—BEDSTEAD.

BILL OF MATERIAL.

2 pieces yellow pine 1" x 9" x 3' 8".	Head.
1 piece yellow pine 1" x 12" x 3' 8".	Foot.
2 pieces yellow pine 1" x 9" x 6' 8".	Sides and cleats.
2 pieces yellow pine 2" x 4" x 2' 8".	Head posts.
2 pieces yellow pine 2" x 4" x 2' 1".	Foot posts.
2 pieces yellow pine 2" x 6" x 3' 6".	Bottom.
6 pieces yellow pine 1" x 6" x 3' 6".	Bed slats.

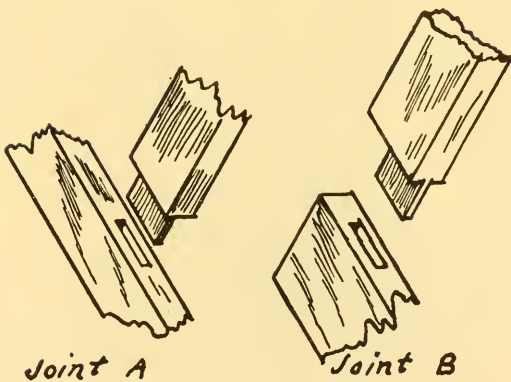
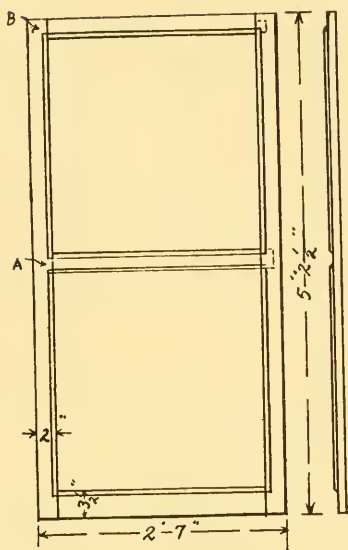

FIG. 21.—WINDOW SCREEN.

BILL OF MATERIAL.

- 2 pieces yellow pine $1\frac{1}{8}$ " x 3" x 5' 4"..... Stiles.
- 2 pieces yellow pine $1\frac{1}{8}$ " x 3" x 2' 7"..... Rails.
- 1 piece yellow pine $1\frac{1}{8}$ " x 3" x 2' 7"..... Lower rail.
- 30 feet screen binding $\frac{1}{4}$ " x $\frac{3}{8}$ ".

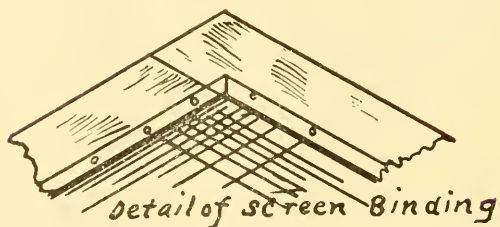
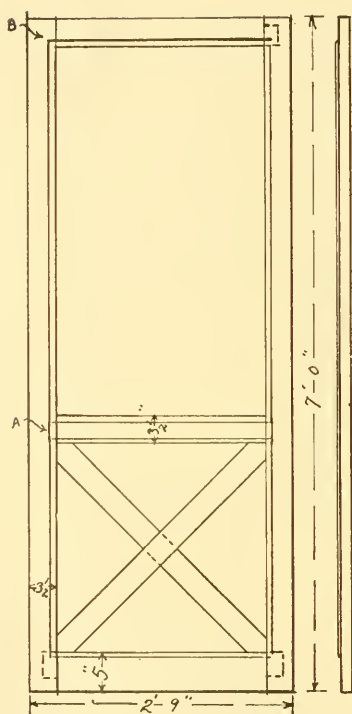

FIG. 22.—DOOR SCREEN.

BILL OF MATERIAL.

2 pieces yellow pine	$1\frac{1}{4}'' \times 4'' \times 7' 2''$	Stiles.
2 pieces yellow pine	$1\frac{1}{2}'' \times 4'' \times 2' 8''$	Rails.
1 piece yellow pine	$1\frac{1}{2}'' \times 5\frac{1}{2}'' \times 2' 1''$	Lower rail.
2 pieces yellow pine	$1\frac{1}{4}'' \times 4'' \times 3' 2''$	Braces.
24 feet screen binding	$\frac{1}{4}'' \times \frac{5}{8}''$.	

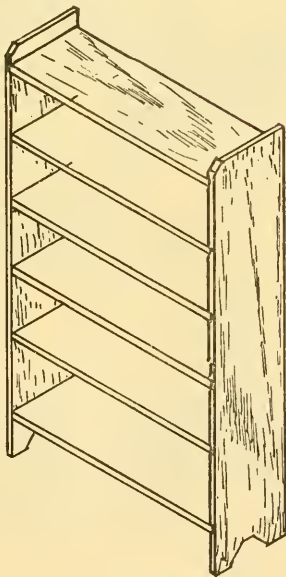
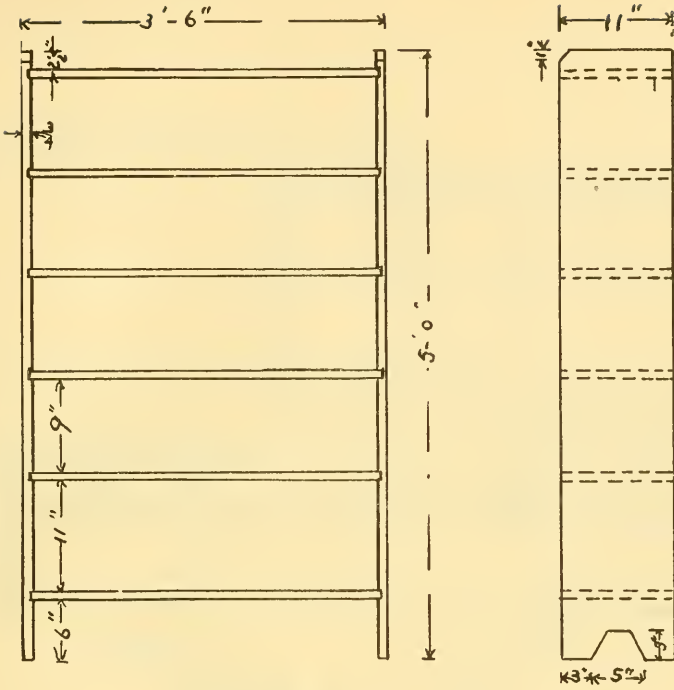

FIG. 23.—BOOKCASE.

BILL OF MATERIAL.

- 2 pieces yellow pine 1" x 12" x 5' 2"..... Sides.
- 6 pieces yellow pine 1" x 12" x 3' 6"..... Shelves.

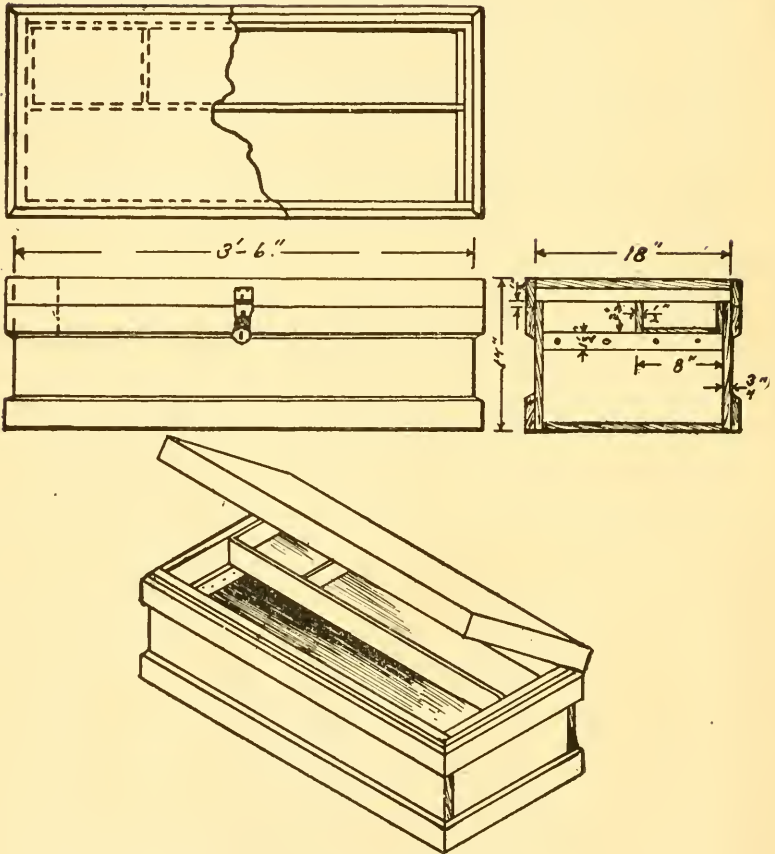

FIG. 24.—TOOL CHEST.

BILL OF MATERIAL.

4 pieces yellow pine	1" x 8" x 4' 8"	Sides.
4 pieces yellow pine	1" x 8" x 1' 6"	Ends.
4 pieces yellow pine	1" x 10" x 4' 8"	Top and bottom.
6 pieces yellow pine	1" x 3 1/2" x 4' 10"	Base and top strips.
6 pieces yellow pine	1" x 3 1/2" x 1' 10"	Base and top strips.
1 piece poplar	1/2" x 9" x 7' 0"	Tray.

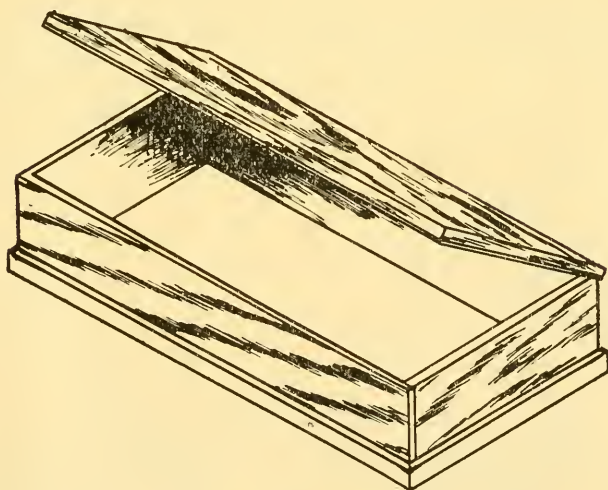
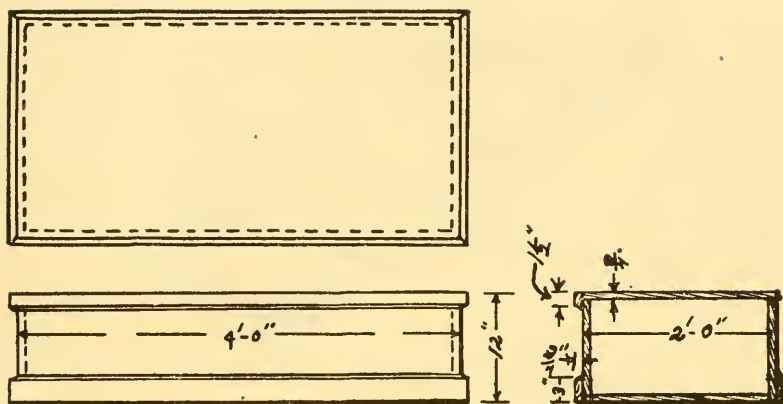
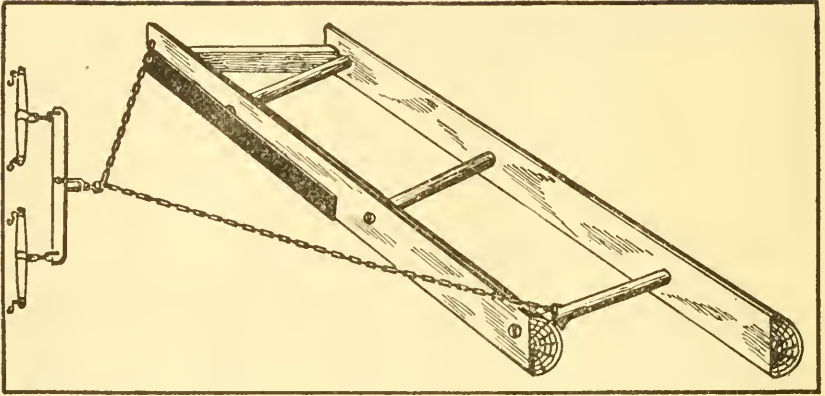

FIG. 25.—CLOTHES BOX.

BILL OF MATERIAL.

- 2 pieces yellow pine 1" x 12" x 4' 2"..... Sides.
- 2 pieces yellow pine 1" x 12" x 2' 0"..... Ends.
- 6 pieces yellow pine 1" x 9" x 4' 2"..... Top and bottom.
- 3 pieces yellow pine 1" x 3 3/4" x 4' 4"..... Base.
- 2 pieces yellow pine 1" x 2" x 4' 4"..... Edge of top.



Perspective view.

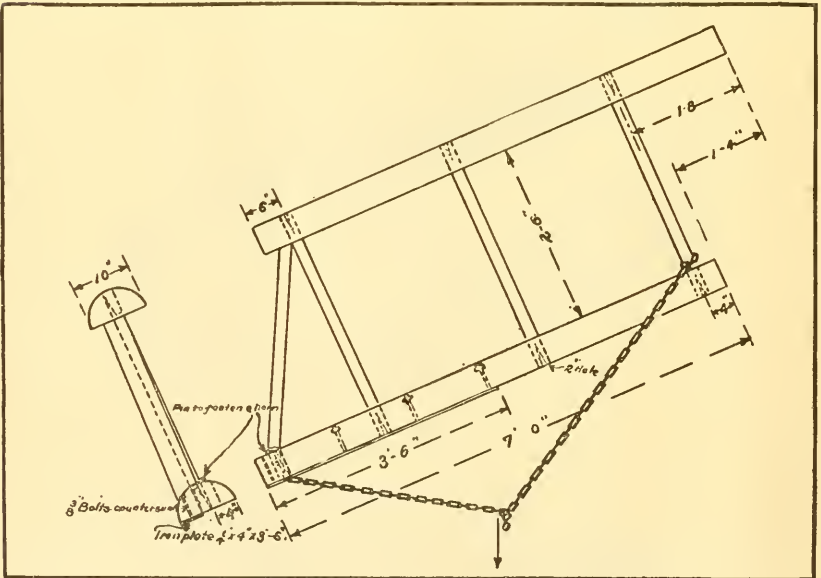

Plan and elevation.

FIG. 26.—SPLIT-LOG DRAG.

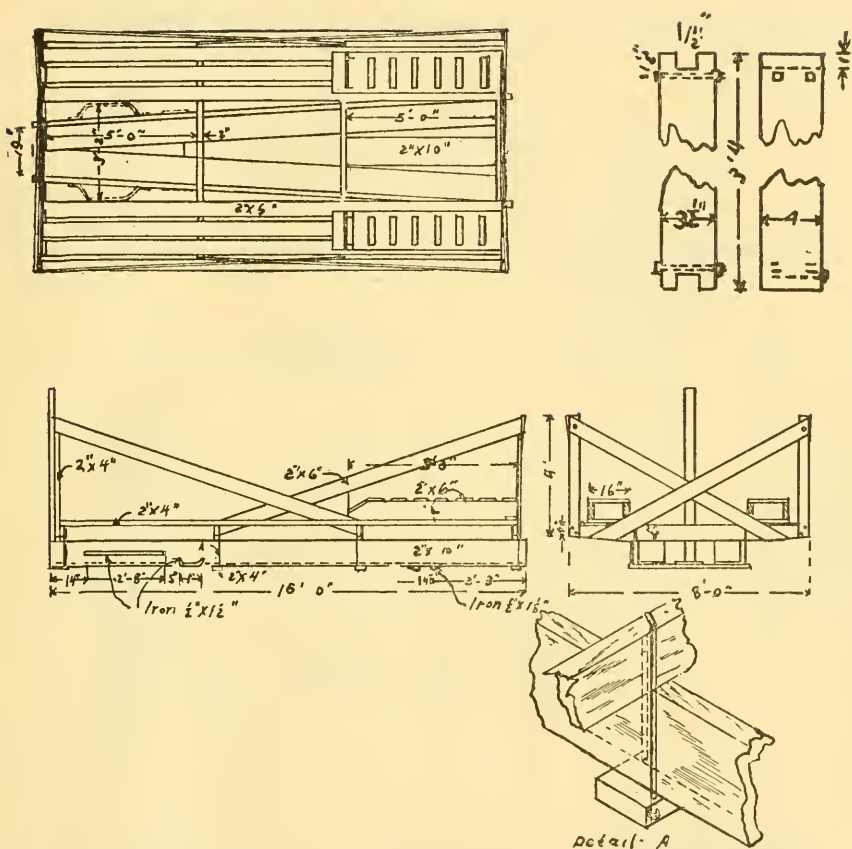

FIG. 27.—HAYRACK.

BILL OF MATERIAL.

- 2 pieces yellow pine 2" x 10" x 16' 0"
- 4 pieces yellow pine 2" x 6" x 8' 0"
- 4 pieces yellow pine 2" x 4" x 4' 2"
- 2 pieces yellow pine 2" x 4" x 15' 8"
- 4 pieces yellow pine 2" x 4" x 4' 0"
- 1 piece yellow pine 2" x 4" x 6' 2"
- 4 pieces yellow pine 2" x 4" x 1' 4"

- 4 pieces yellow pine 2" x 8" x 5' 8"
- 16 pieces yellow pine 1" x 6" x 1' 4"
- 4 pieces yellow pine 1" x 6" x 11' 0"
- 4 pieces yellow pine 1" x 6" x 9' 0"
- 6 pieces yellow pine 1" x 6" x 16' 0"
- 2 pieces yellow pine 1" x 10" x 16' 0"
- 1 piece yellow pine 1" x 10" x 11' 0"

HARDWARE.

- 6 bolts 3/8" x 6"
- 16 bolts 3/8" x 4"
- 8 clips, bolt 1/2" x 19"

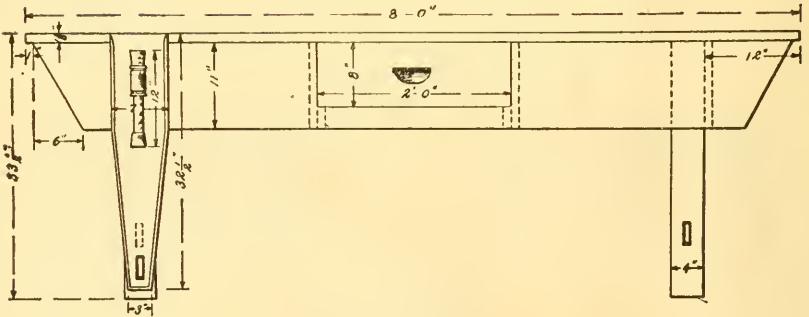
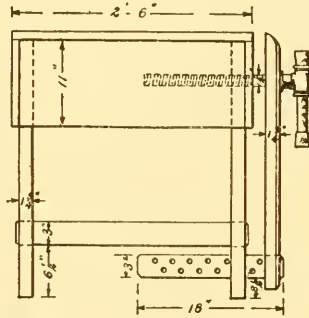
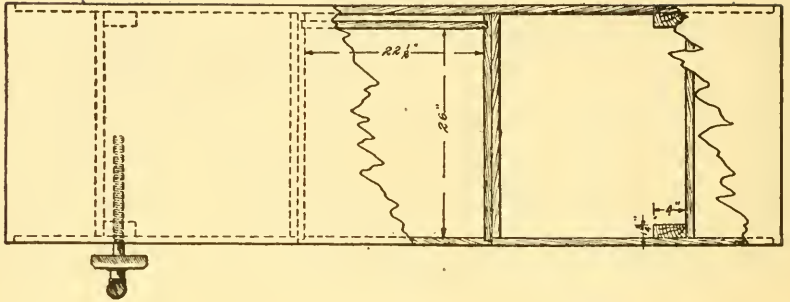
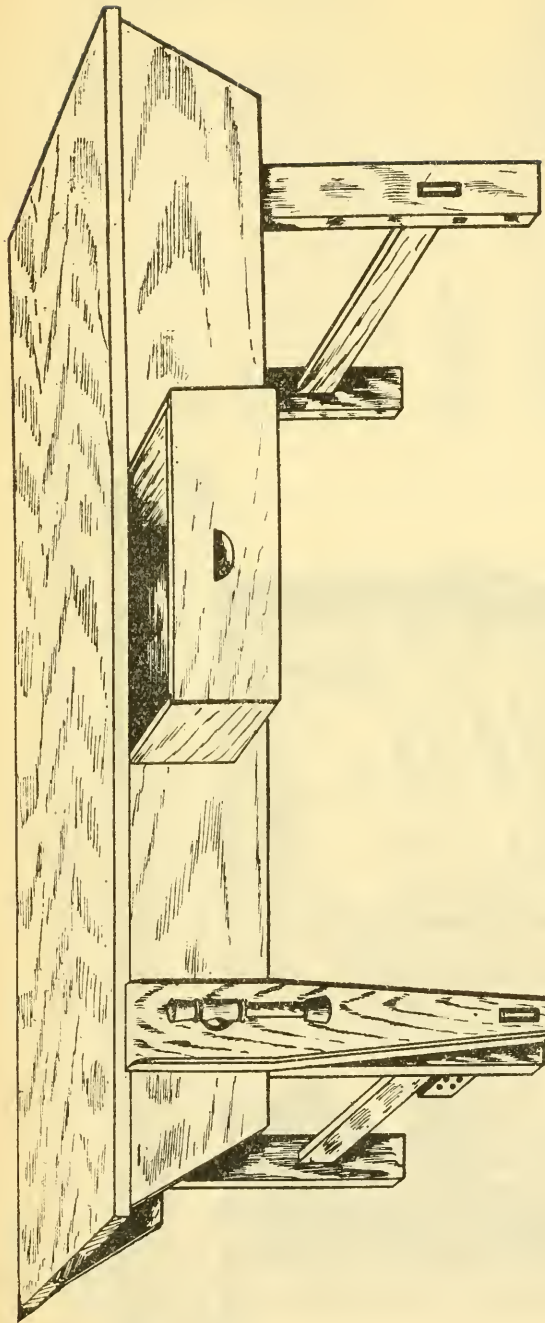

FIG. 28.—DETAILS OF A CHEAP WORKBENCH.



CHEAP WORKBENCH.

BILL OF MATERIAL.

3 pieces $1\frac{1}{2}$ " x 12 " x $8'$ 0"	Top.
2 pieces $1\frac{1}{2}$ " x 12 " x $8'$ 0"	Sides.
4 pieces $1\frac{1}{2}$ " x 12 " x $2'$ 6"	End and center crosspieces.
2 pieces $1\frac{1}{2}$ " x $3\frac{1}{2}$ " x $2'$ 6"	Cross rails.
1 piece $1\frac{1}{2}$ " x $3\frac{1}{2}$ " x $1'$ 8"	Vise piece.
4 pieces $2\frac{1}{2}$ " x $4\frac{1}{2}$ " x $2'$ 9"	Legs.
2 pieces $1\frac{1}{2}$ " x 8 " x $2'$ 6"	Drawer sides.
1 piece $1\frac{1}{2}$ " x 8 " x $2'$ 6"	Drawer ends.
3 pieces $1\frac{1}{2}$ " x 9 " x $2'$ 6"	Poplar panel, drawer bottom.
1 piece $2\frac{1}{2}$ " x 8 " x $2'$ 9"	Vise block, oak.
Use oval for drawer slides, etc.	

HARDWARE.

1 vise screw, $1\frac{1}{2}$ "	
2 pounds nails, 8-d., common.	
2 pounds nails, 8-d., casing.	

RECAPITULATION.

30 feet lumber, $1\frac{1}{2}$ " x 12 " x $8'$, "B" yellow pine finish, at \$45 per M.	\$1.35
34 feet lumber, $1\frac{1}{2}$ " x 12 " x $8'$, "B" yellow pine finish, at \$45 per M.	1.33
8 feet lumber, $2\frac{1}{2}$ " x $4\frac{1}{2}$ " x $12'$, "B" yellow pine, common, at \$27 per M.	.22
4 feet lumber, $2\frac{1}{2}$ " x 8 " x $3'$, "B" oak, at \$50 per M.	.20
6 feet lumber, $\frac{1}{2}$ " x 9 ", poplar panel, at \$70.	.42
Cost of lumber	3.72

HARDWARE.

1 vise screw, $1\frac{1}{2}$ "	.60
2 pounds nails, 8-d., common, at \$0.033	.07
2 pounds nails, 8-d., casing, at \$0.033	.07
Cost of hardware	.74
Carpenter labor to be done by students	.80
$\frac{1}{2}$ gallon ready-mixed paint, at \$1.60 per gallon	3.72
Cost of lumber	3.72
Total cost	5.26

BILL OF MATERIAL.

- 1 bench top, as per drawing, or
 3 pieces, 2" x 10" x 6' 0", "A," yellow pine finish.
 4 pieces, 3" x 2" x 2' 10", "A," yellow pine finish... Corner post.
 4 pieces, 3" x 3" x 2' 0", "A," yellow pine finish... End rails.
 4 pieces, 3" x 3" x 4' 0", "A," yellow pine finish... Side rails.
 2 pieces, 1" x 3" x 4' 3", "A," yellow pine finish... End base.
 2 pieces, 1" x 3" x 2' 2", "A," yellow pine finish... Bottom.
 3 pieces, 1" x 10" x 4' 0", "A," yellow pine finish... Partition.
 3 pieces, 1" x 10" x 2' 8", "A," yellow pine finish... Stiles and muntins for
 back and ends.
 5 pieces, 1" x 2" x 2' 6", "A," yellow pine finish... Panels, back and ends.
 8 pieces, 1" x 10" x 2' 6", "A," yellow pine finish... Door stiles.
 2 pieces, 1 1/2" x 2" x 2' 0", "A," yellow pine finish... Muntins.
 1 piece, 1 1/2" x 2" x 2' 0", "A," yellow pine finish... Rails.
 2 pieces, 1 1/2" x 3" x 2' 2", "A," yellow pine finish... Panels.
 1 piece, 1 1/2" x 2" x 2' 4", "A," yellow pine finish... Hanging stile.
 8 pieces, 1 1/2" x 6" x 1' 3", "A," yellow pine finish... Drawer fronts.
 4 pieces, 1 1/2" x 6" x 1' 3", poplar panel... Drawer sides.
 4 drawer bottoms, 3/4" poplar panel... Drawer ends.
 1 set oval for drawer slides, etc.

HARDWARE.

- 1 pair hinges, tight pin butts.
 5 locks, drawer.
 16 3/4" x 6" lag screws.

RECAPITULATION.

27 feet lumber, 3" x 3" x 12', "A," yellow pine finish, at \$50 per M.	\$1.35
40 feet lumber, 1" x 10" x 16', "A," yellow pine finish, at \$50 per M.	2.00
12 feet lumber, 1" x 12" x 12', "A," yellow pine finish, at \$50 per M.	.60
18 feet lumber, 1 1/2" x 12" x 16', "A," yellow pine finish, at \$50 per M.	1.30
30 feet lumber, 2" x 10" x 6' or 12', "A," yellow pine finish, at \$50 per M.	1.50
30 feet lumber, 3" x 6" x 12', poplar panel, at \$70 per M.	2.10
1 pair hinges, 3" x 2 1/2", tight pin butts	.15
5 locks, drawer, No. R. A. 342 Yale & Towne, for 1 1/2" wood, at \$0.70 each.	3.50
16 lag screws, 3/4" x 6", at \$0.04 each.	.65
Carpenter labor.	12.25
Total.	25.00
Extra for maple top.	6.00
Cost.	31.00

MANUAL TRAINING WORKBENCH.

PAINT MATERIAL.

1 quart white shellac.	.75
3 pints coach varnish	1.20
Total cost.	32.95

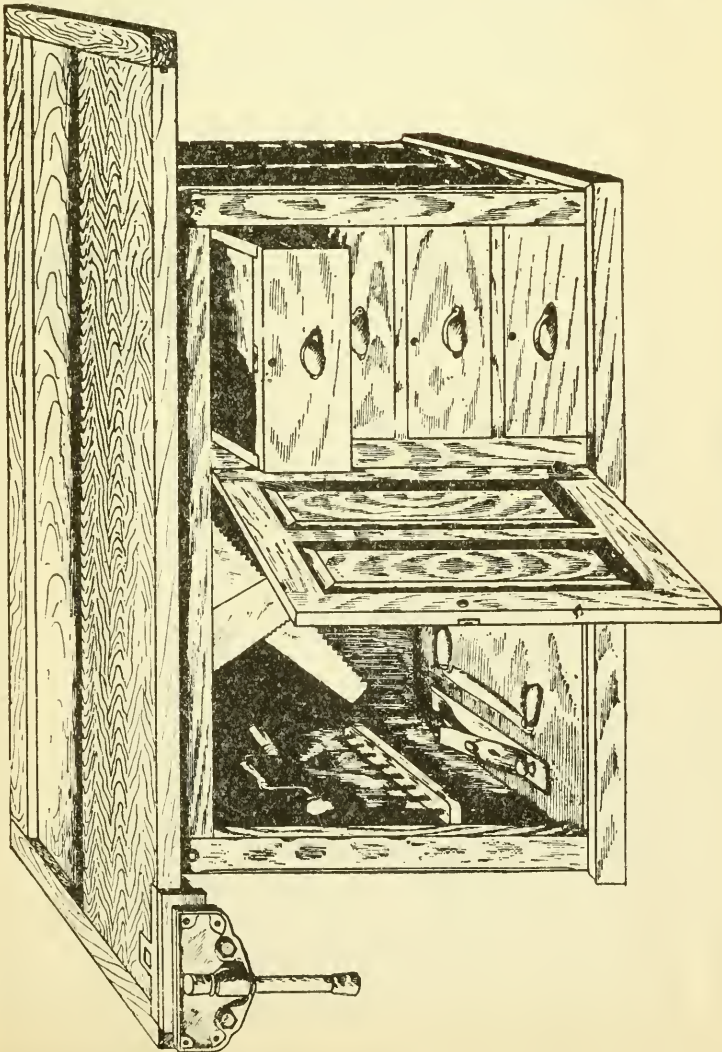

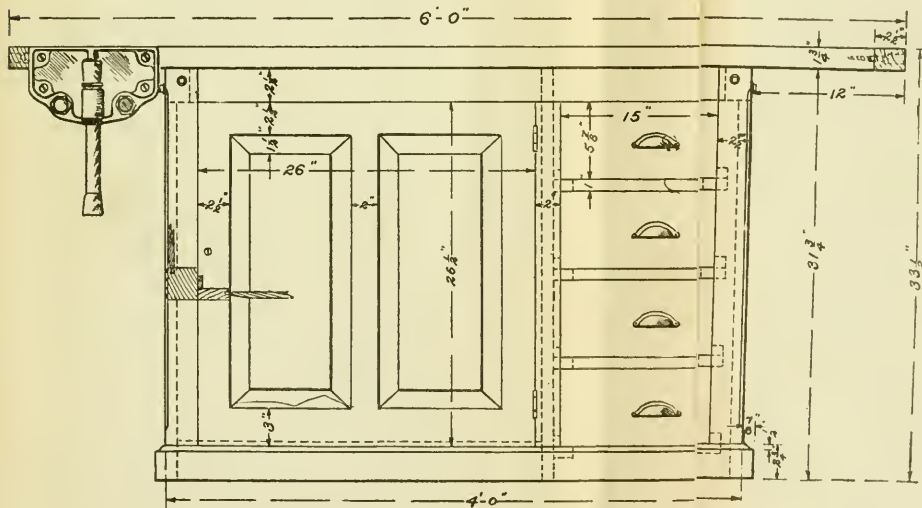
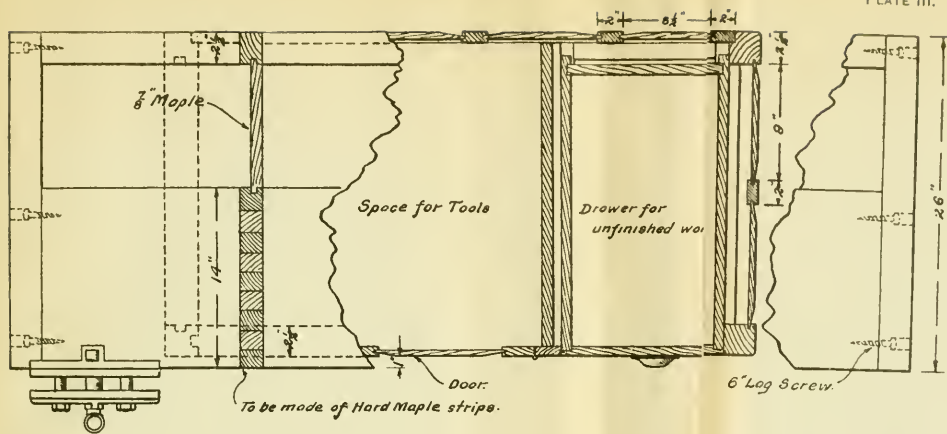

DETAILS OF MANUAL TRAINING WORKBENCH.

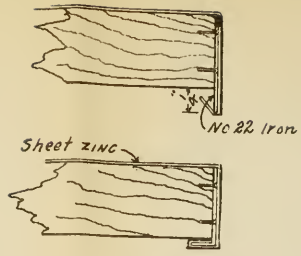
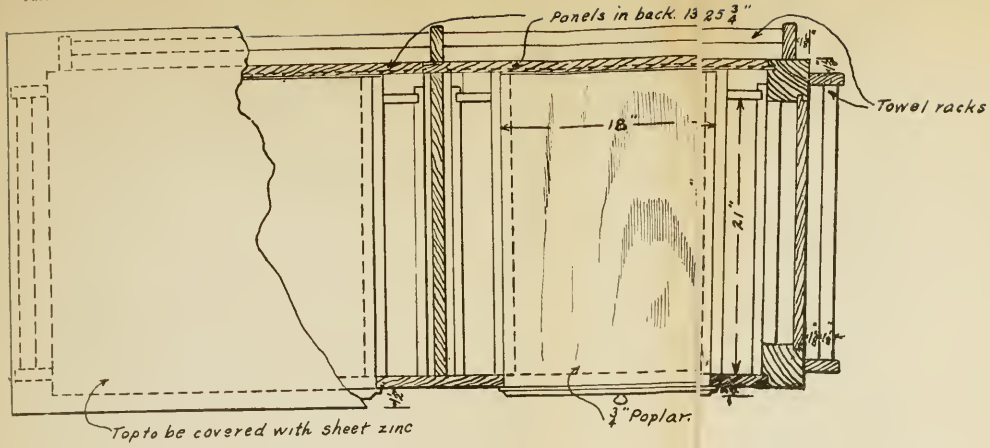

Method of fastening zinc on top.

BILL OF MATERIAL.

- 4 pieces, 1" x 8" x 5' 8", "A" yellow pine finish Top.
- 4 pieces, 4" x 4" x 2' 7", "A" yellow pine finish Table legs.
- 4 pieces, 1 1/2" x 3" x 1' 9", "A" yellow pine finish End rails.
- 4 pieces, 1 1/2" x 3" x 3' 0", "A" yellow pine finish Side rails.
- 2 pieces, 1 1/2" x 2 1/2" x 1' 3", "A" yellow pine finish Front and back muntins.
- 4 pieces, 1" x 3" x 1' 9", "A" yellow pine finish End panels.
- 4 pieces, 1" x 8" x 2' 3", "A" yellow pine finish Back panels.
- 2 pieces, 1" x 8" x 2' 0", "A" yellow pine finish Partition.
- 1 piece, 1 1/2" x 9" x 5' 0", "A" yellow pine finish Brackets.
- 14 pieces, 1 1/2" x 3 1/2" x 2' 3", "A" yellow pine finish Drawer slides.
- 6 pieces, 1" x 3" x 2' 0", "A" yellow pine finish Bread board fronts, slides, etc.
- 4 pieces, 2" x 2" x 2' 6", "A" yellow pine finish Towel hangers.
- 3 pieces, 1 1/2" x 10" x 2' 3", "A" yellow pine finish Drawer fronts.
- 6 pieces, 1" x 9" x 2' 0", poplar panel Drawer sides.
- 3 pieces, 1" x 9" x 2' 3", poplar panel Drawer ends.
- 4 drawer bottoms, 1/2" poplar panel, 18 square feet Drawer bottoms.
- 4 pieces, 1" x 10" x 2' 2", poplar Bread boards.

HARDWARE.

- 1 piece sheet zinc, 36" x 72" For top.
- 1 piece iron, No. 22, 1 1/2" x 16' long Around top.
- 8 drawer pulls.

RECAPITULATION AND COST OF MATERIAL.

35 feet lumber, 1" x 8" x 12", "A" yellow pine, at \$50 per M	\$1.75
35 feet lumber, 1 1/2" x 10" x 12", "A" yellow pine, at \$50 per M	1.75
15 feet lumber, 4" x 4", "A" yellow pine, at \$50 per M	.75
4 feet lumber, 2" x 2" x 10", "A" yellow pine, at \$50 per M	.20
8 feet lumber, 1" x 10" x 9", poplar, at \$70 per M	.56
33 feet lumber, 1" x 6" to 12", poplar panel, at \$70 per M	2.31
1 piece sheet zinc, 36" x 72"	1.50
1 piece iron, No. 22, 1 1/2" x 16' long	.30
8 drawer pulls, at 10 cents each	.80
Amount	9.92
Carpenter labor	10.75
Cost of construction	20.67

PAINT MATERIAL.

1 quart white shellac	.75
3 pints coach varnish	1.20
Total cost	22.62

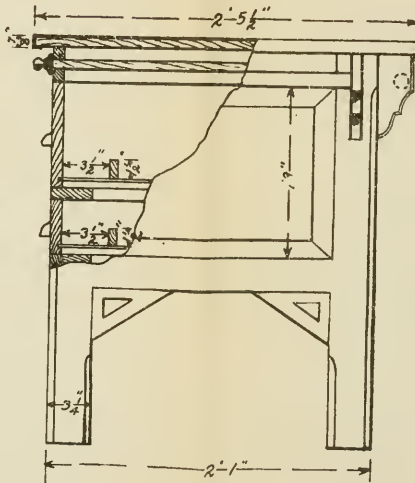
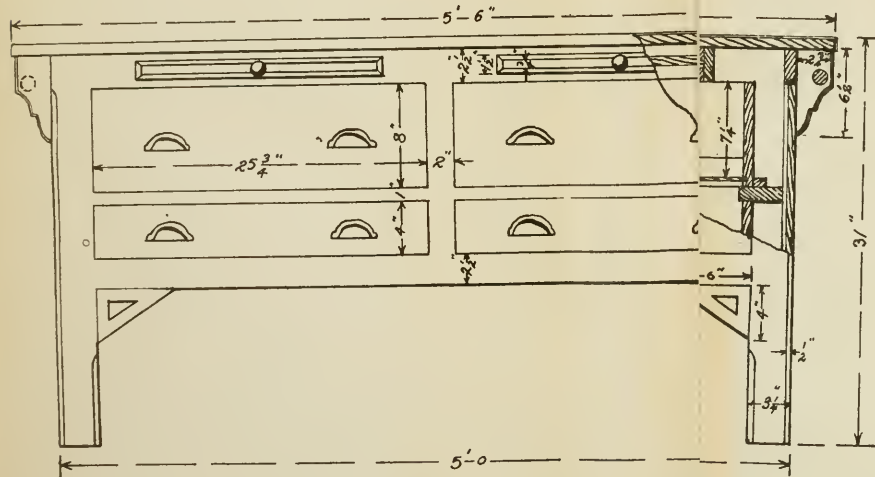

DOMESTIC SCIENCE TABLE.

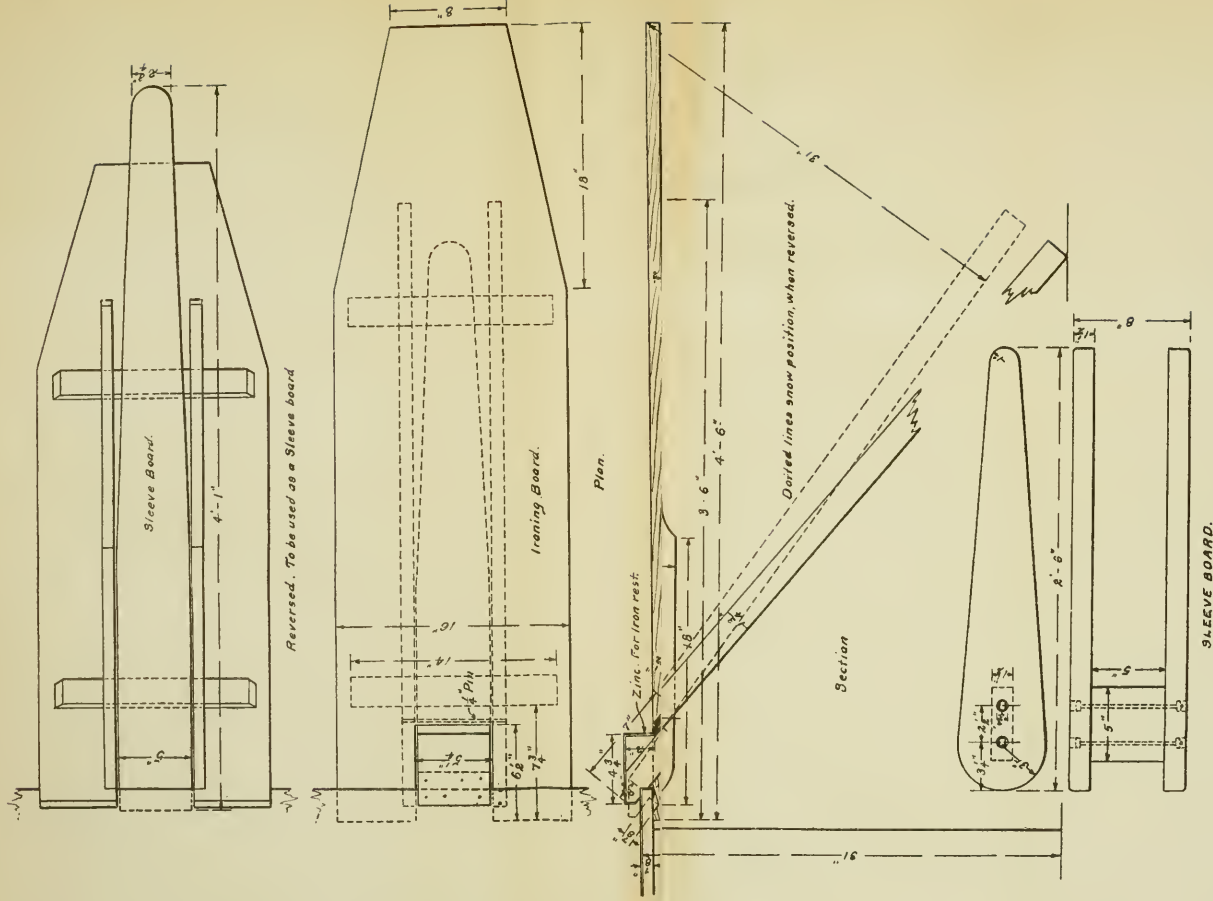

IRONING BOARD TO BE USED WITH DOMESTIC SCIENCE COOK TABLE.

BOSTON PUBLIC LIBRARY



3 9999 05677 135 3

