

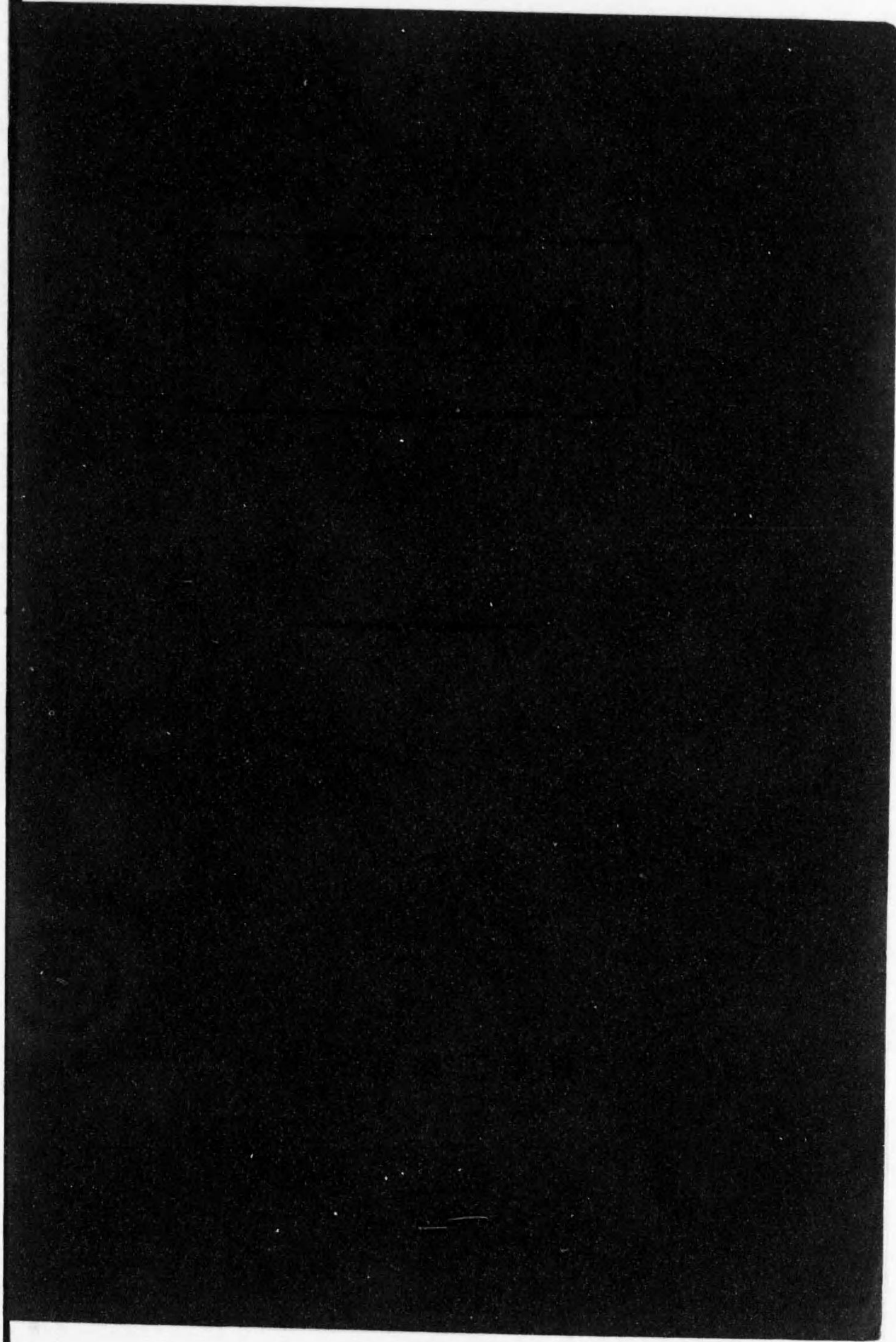

始



造船學附圖

長崎三菱職工學校

特 204
102

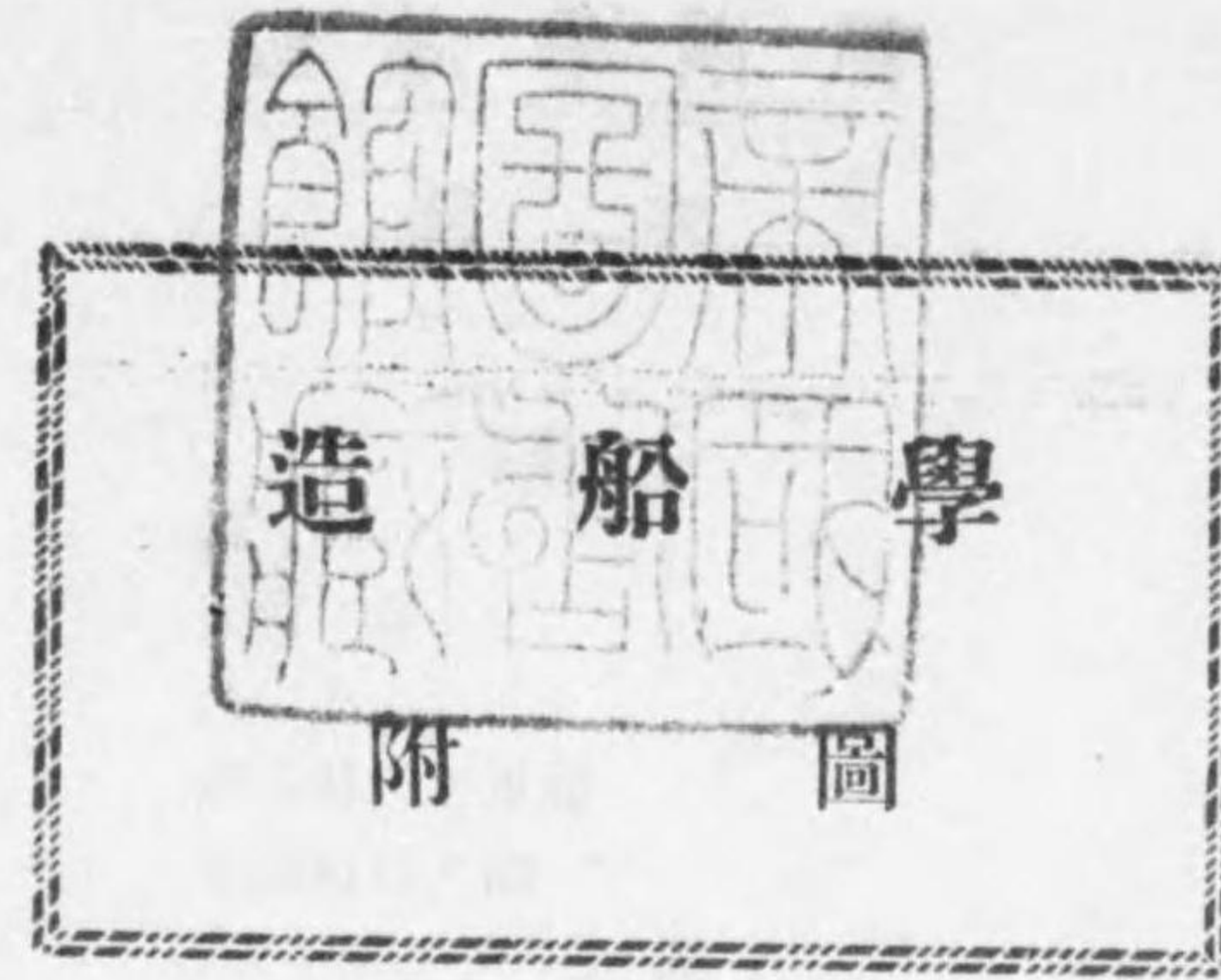

長崎三菱職工學校





對學工維達三備具

造船學附屬

目次

圖番號	名稱	頁
1	筏舟	1
2	太古ノ舟	1
3	全上	2
4	羅馬時代ノ軍船	2
5	希臘時代ノ船	2
6	「サンタマリア」ノ圖	3
7	十九世紀頃ノ帆船	4
8	平家ノ軍船	4
9	御朱印船	5
10	發明當時ノ蒸汽船	5
11	軍艦	6
12	潜水艦	6
13	巡洋戰艦	7
14	汽船發達ノ一覽	8
15-18	船殼構造ノ變遷	9
19-23	船型ノ種類	10
24-28	全上	11
29-33	全上	12
34-38	外力ヲ受ケタル船體ノ歪	13
39-40	全上	14
41	商船中央部切斷面	15
42	軍艦中央部切斷面	16
43-53	造船使用材料ノ斷面	17
54-64	鉸釘	18
65-72	接合法及鉸釘配列法	19
73-75	單底構造	20
76-78	船首ノ形狀	21
79-81	船首材	22

82-83	軍艦ノ武装略圖	23
84	軍艦ノ船首材	24
85	簡單ナル船尾材	25
86	單開車船ノ船尾材及舵	26
87	隻開車船ノ船尾材	27
88	巡洋艦型船尾材及舵	28
89	三開車船ノ船尾	29
90	軍艦ノ船尾材	30
91	推進器支柱	31
92-93	全上	32
94	全上	33
95	懸垂舵及其取付	34
96	舵頭接合	35
97	鑄造舵	36
98	軍艦ノ舵	37
99	「キツチエン」式舵	38
100	「ドックスフォード」式舵	39
101	「スエズ」運河用舵	40
102	船首舵	41
103A	「フレットナー」式舵	42
103B	全上	43
104	普通型船殻構造	44
105	「インヤウツド」式船殻構造	44
106	肋骨ノ形狀	45
107	單底肋板	46
108	方形龍骨	47
109	「マツキンクイヤー」二重底	48
110A-B	縱強式二重底略圖	49
111A-B	橫強式二重底略圖	50
112	船側縱通材	51
113	船首防撓構造	52
114	全上	53
115	「ガセツト」	54
116A	船首水艙ノ防撓構造	55

116B	全上	56
117	船尾水艙中ノ防撓構造	57
118	後方部ニ於ケル特設肋骨	58
119	「カント」構造	59
120	全上	60
121	「ボツシング」線圖	61
122	「ボツシング」肋骨	62
123	全上平面圖	63
124I	外板ノ張方	64
124II	全上平面圖	65
125	彎曲部龍骨	66
126	梁肢及肘板	67
127	圓形梁柱	68
128	特設梁柱	69
129	商船一般配置圖	70
130	機關室特設梁	71
131	甲板舷側ノ圖	72
132	甲板口補強法	73
133	普通ノ隔壁	74
134	波狀隔壁	75
135	水密區劃ノ圖	76
136	水密扉	77
137	防禦隔壁	88
138	船尾軸及車軸遂道	79
139	機關室	80
140	全上橫斷圖	81
141	載貨口	82
142	全上	83
143	船樓端補強構造	84
144	全上	85
145	機關臺	86
146	內張散內張其他	87
147	人孔蓋	88
148-149	機關臺及推力承臺(タービンエンヂン)	89

150	汽罐臺	90
151	汽罐臺	91
152	木船ノ横断面	92
153—154	特殊船機断面	93
155—156	全上	94
157 ^a	線圖	95
157 ^b	線圖主法表	96
158	排水量計算表	97
159	排水量曲線	98
160	ゼットプロペラー	99
161A-B	外輪車推進器	100
162	四葉螺旋推進器	101
163	三葉全上	102
164	試運轉成績一覽表	103
165	U字形水槽横動搖制止裝置	104
166	「スベラー」式動搖制止裝置	105
167	元良式動搖制止裝置	106
168	コントラプロペラー	107
169	試験水槽略圖	108
170	船用汽罐	109
171—172	全上	110
173	蒸汽機關	111
174A-B	蒸汽機關ノ種別	112
175	送轉「リンク」	113
176	「タービン」ノ模型	114
177	「パーソン」式「タービン」	115
178A-B	「タービン」翼	116
179	機關室一般配置(内燃機關)	117
180A	ブルザー式内燃機關ノ断面	118
180B	全上	119
181	復水機	120
182	「ディーゼル」機關	121
183	「セミディーゼル」機關	122
184	カム	123

185	手働操舵裝置	124
186	操舵輪	125
187A-B	電動水壓式操舵機及「テレモーター」	126
188	電動操舵機	127
189A	揚荷裝置	128
189B	全上	129
190	揚荷機	130
191	橋及動臂起重裝置	130
192	錨	131
193	揚錨裝置	132
194	錨鎖	133
195—197	投錨及繫船要具	134
198—199	全上	135
200A	揚錨機	136
200B	電動車地	137
201	繫船裝置(前方部)	138
202	同上(後方部)	139
203	鋼索ノ断面	140
204	操舵裝置ニ於ケル發條緩衝器	141
205	救命艇配置	141
206	冷凍機	141
207	冷蔵庫ノ絶緣壁	142
208	ニューメーカー吃水測定裝置	143
209	舷梯	144
210	ウェリン式短艇架	145
211	砲塔	146
212	砲彈	147
213	船底測程儀系統圖	148
214	戰艦ノ前後部切断面	149
215	回轉儀羅針盤	150
216	羅針盤方位	150

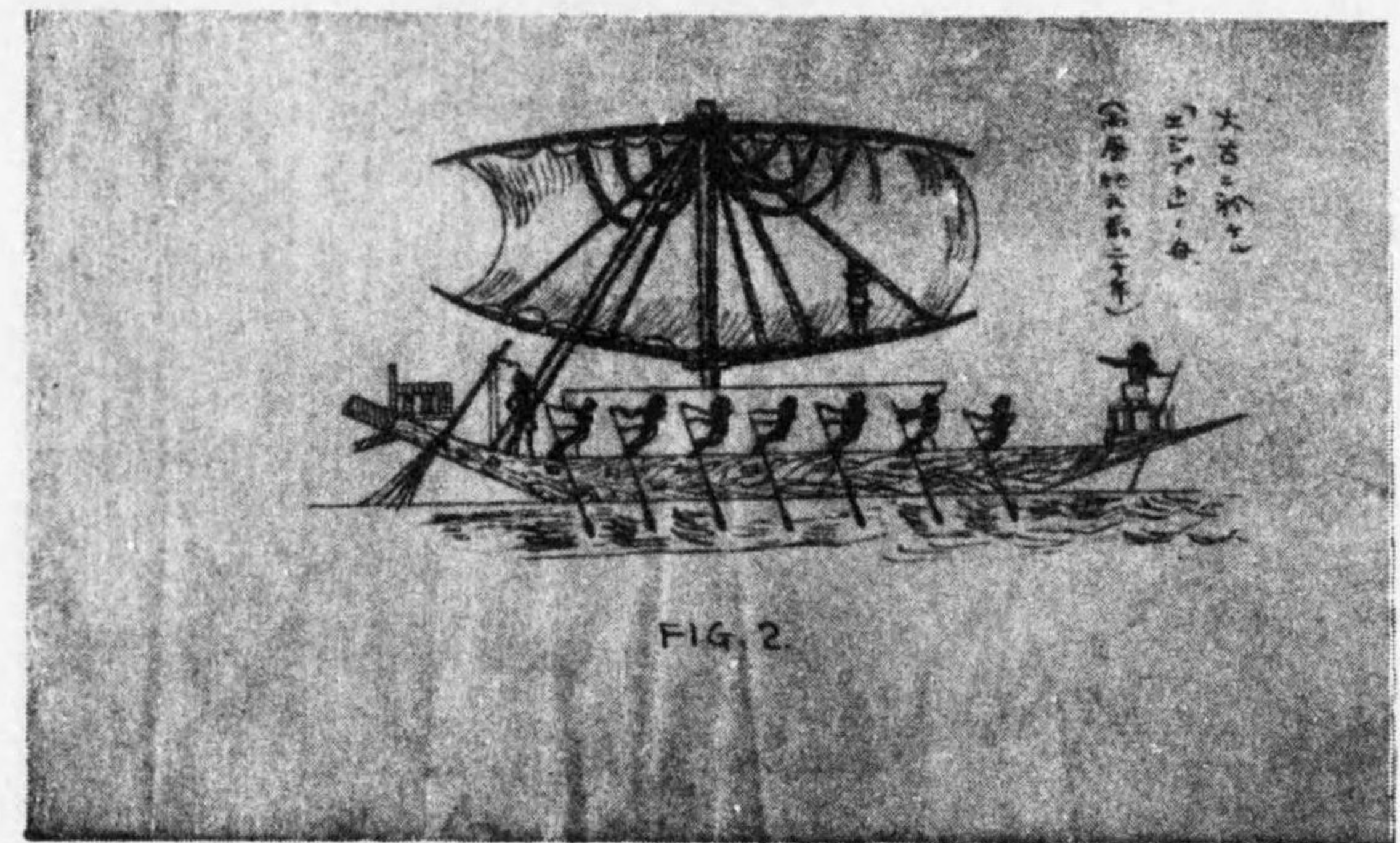
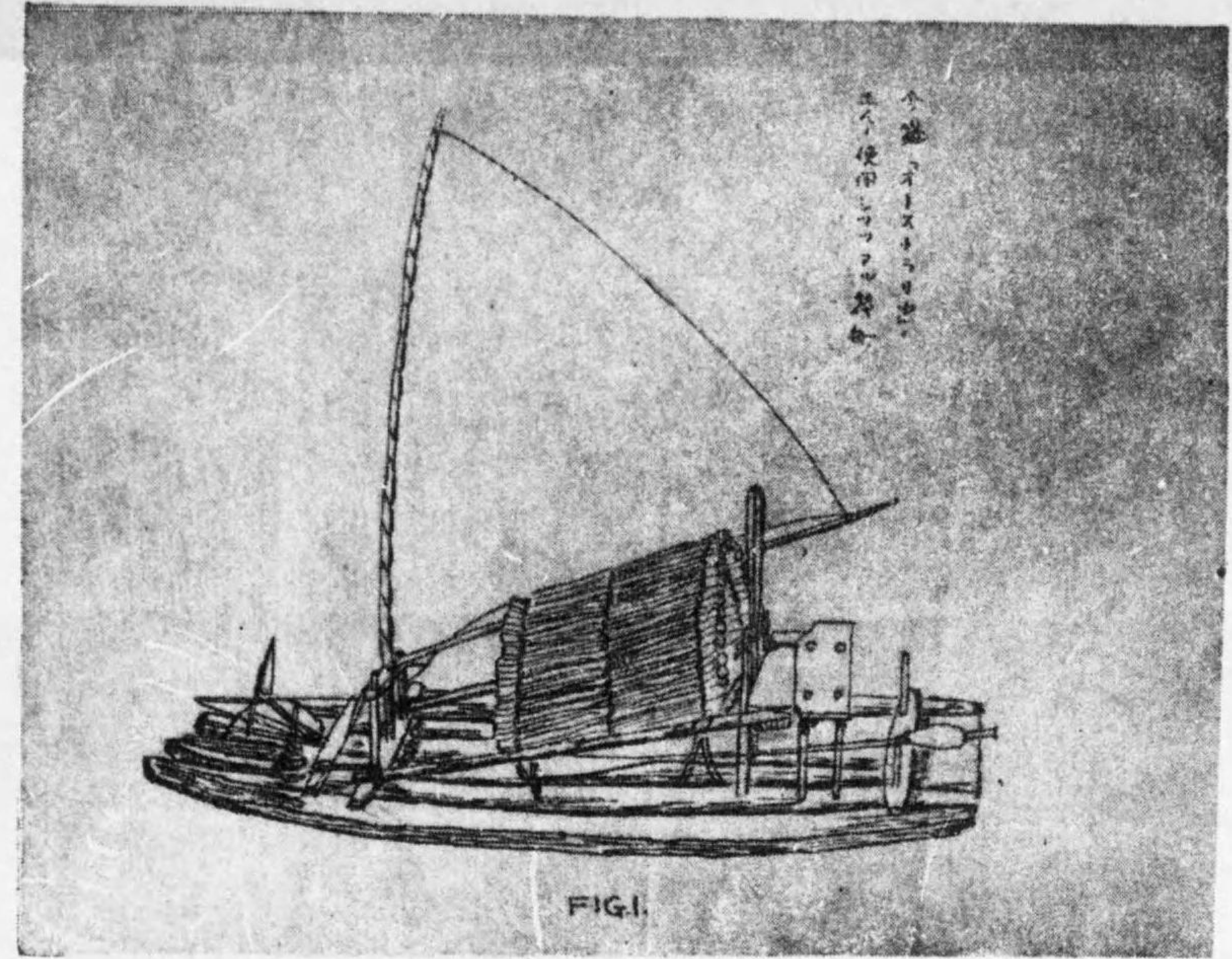

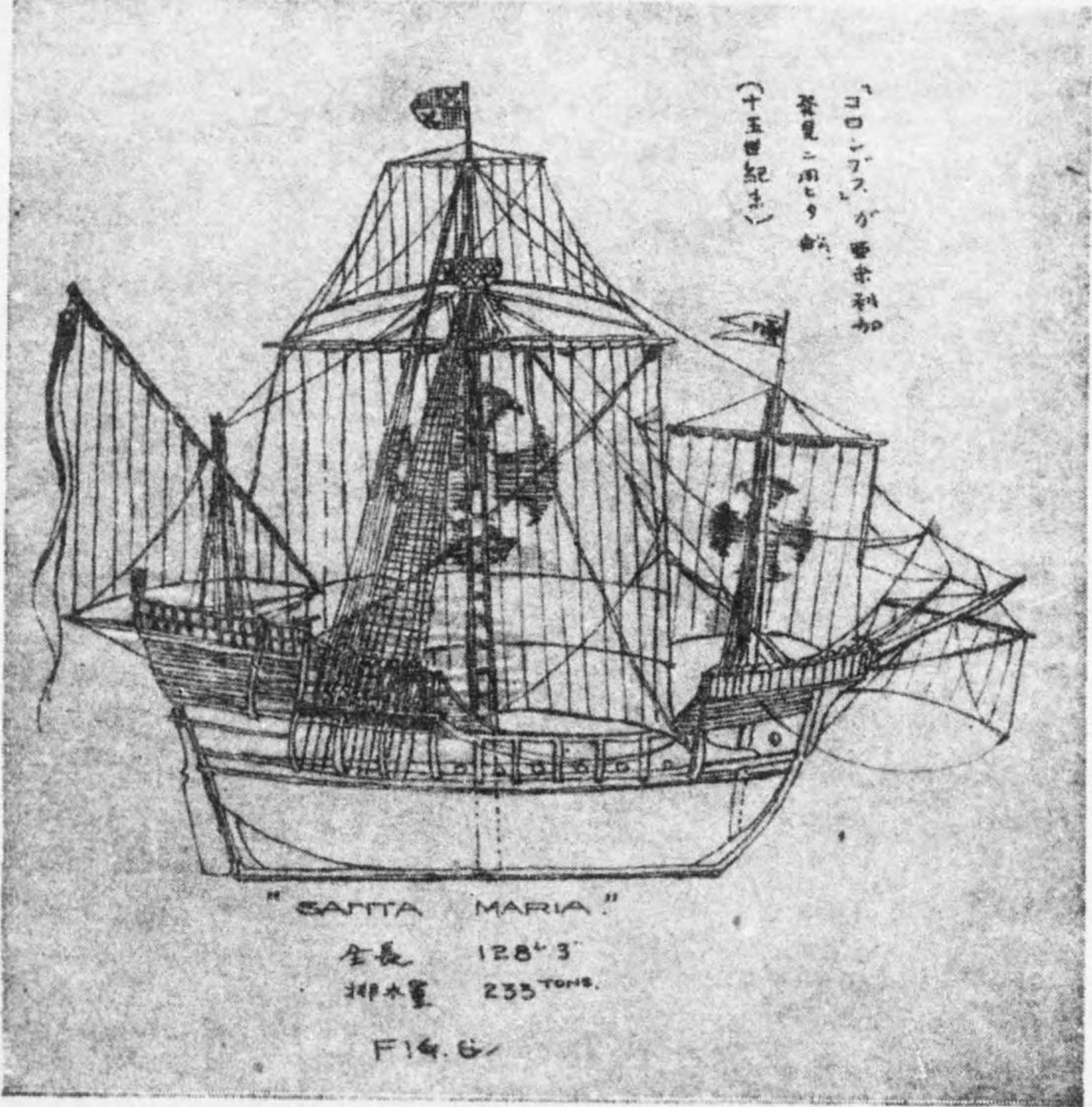
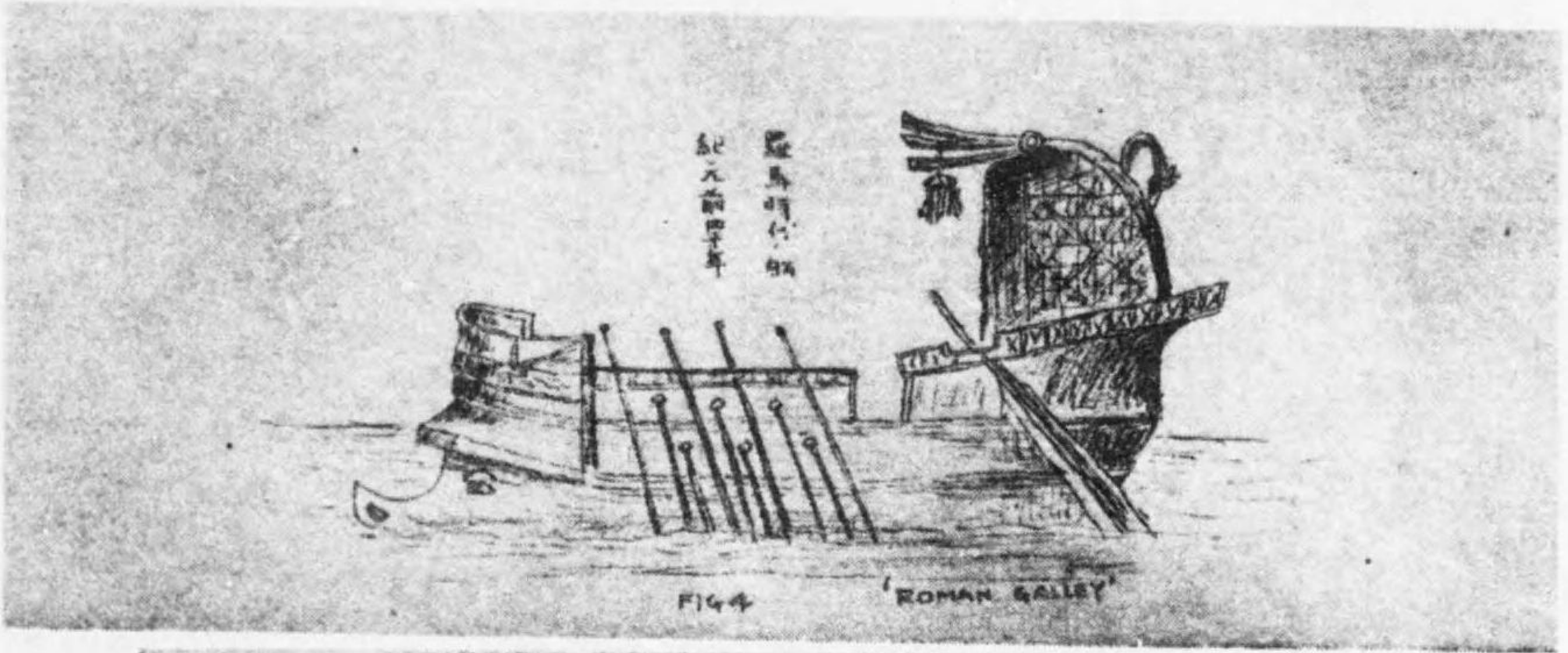
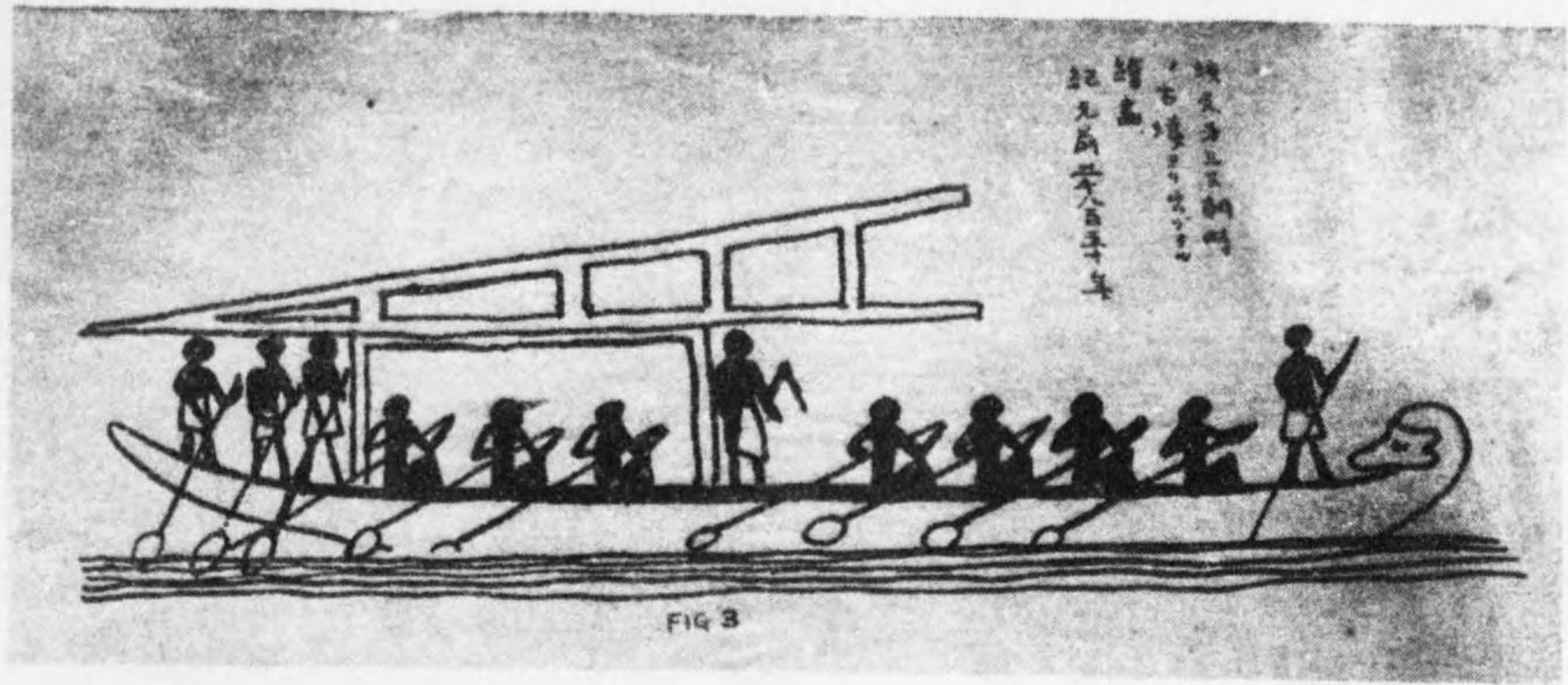
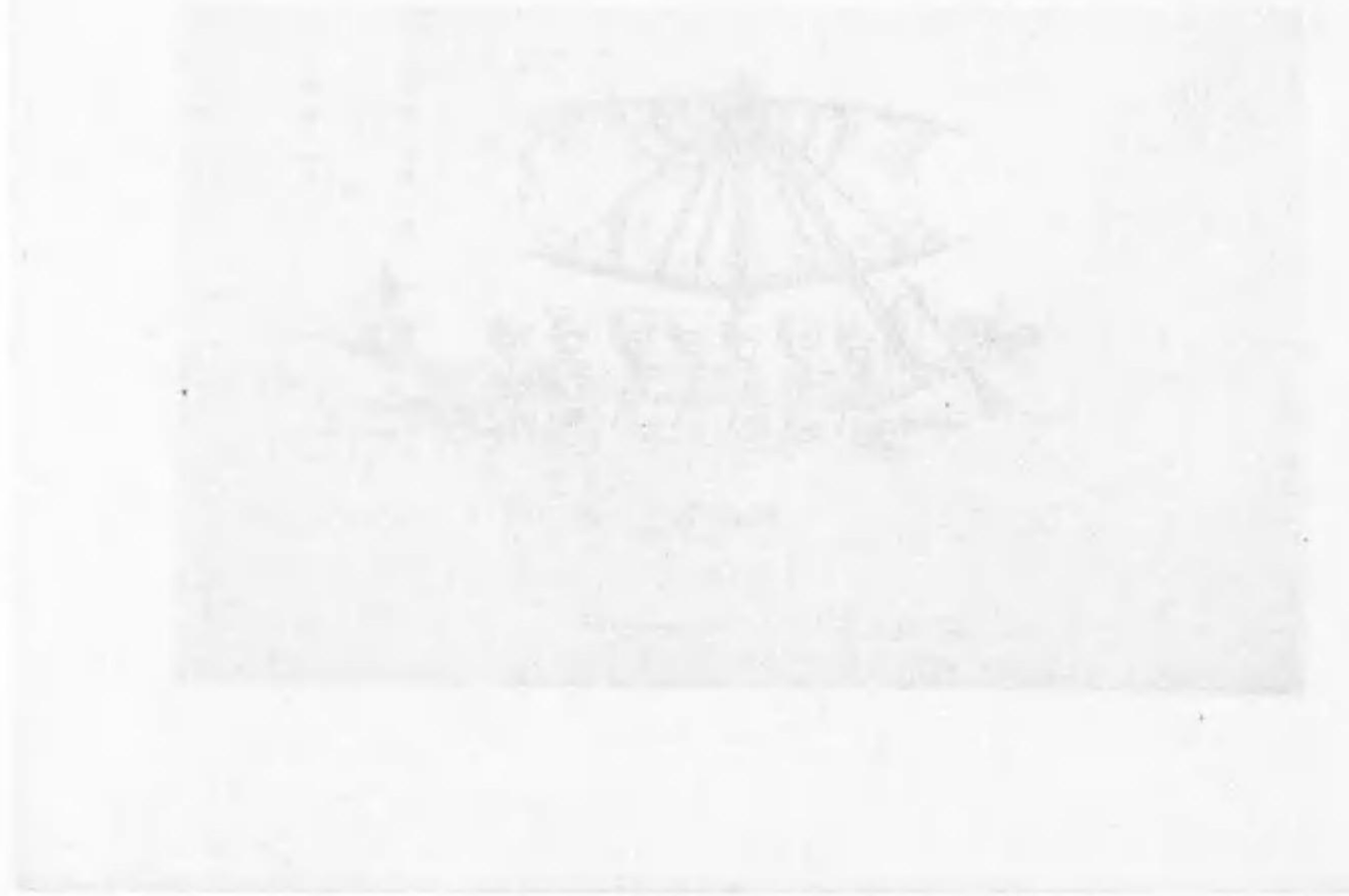
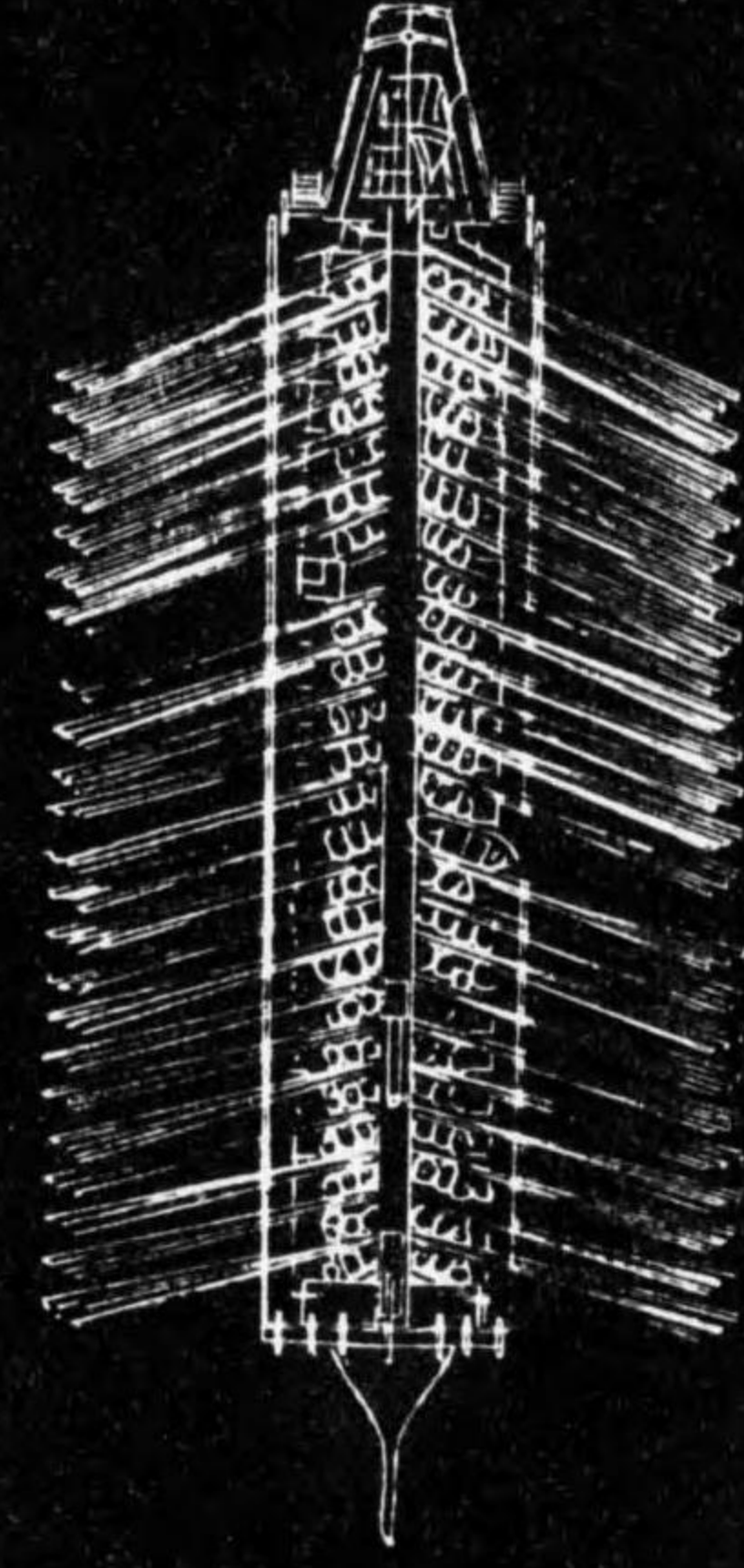
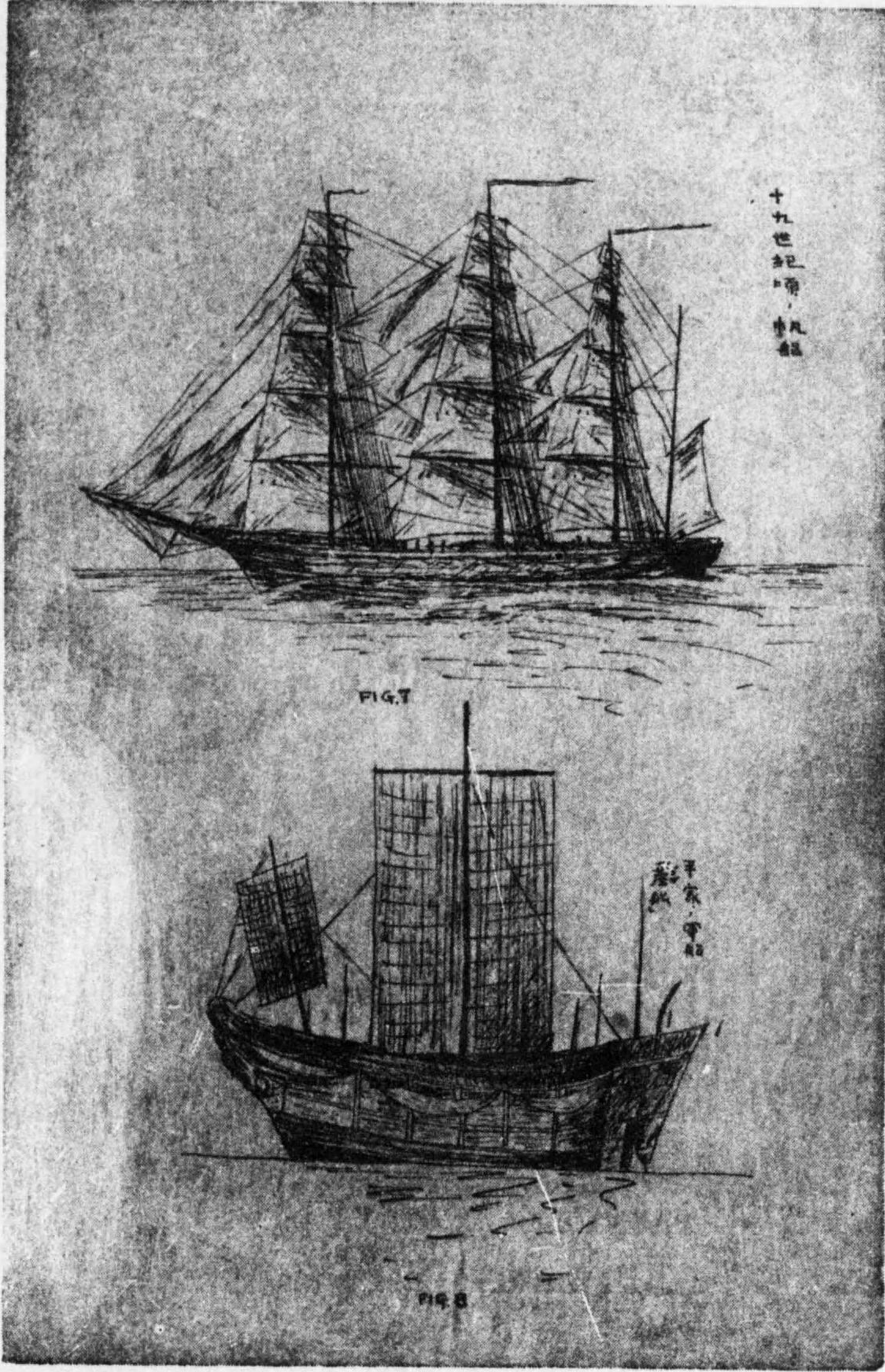

FIG 5

希臘時代，船





十九世紀
帆船

中國
帆船

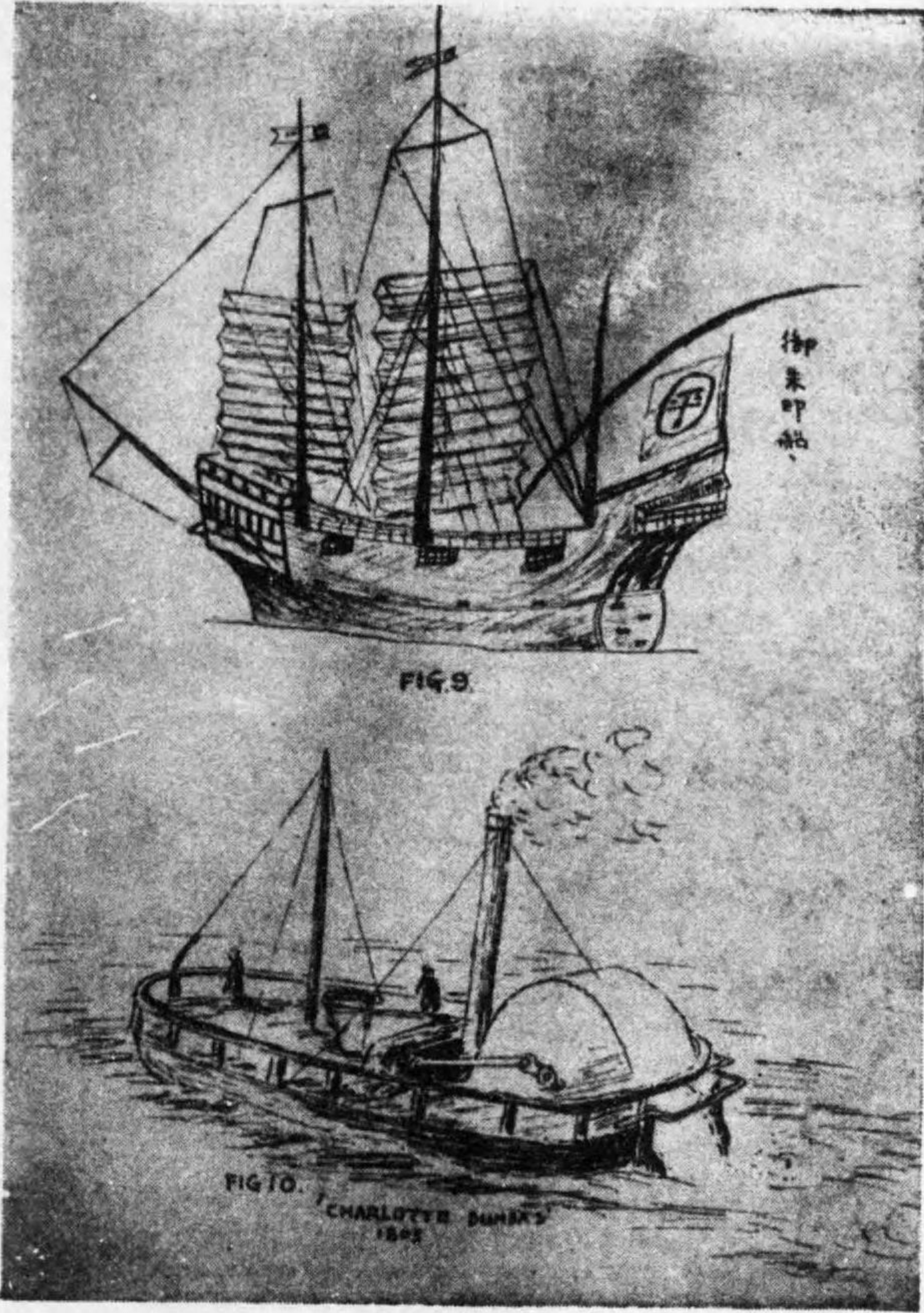



SHIPS OF HIS MAJESTY'S NAVY ORDERED PRIOR TO THE WAR

(FOR DESCRIPTION SEE PAGE 681)

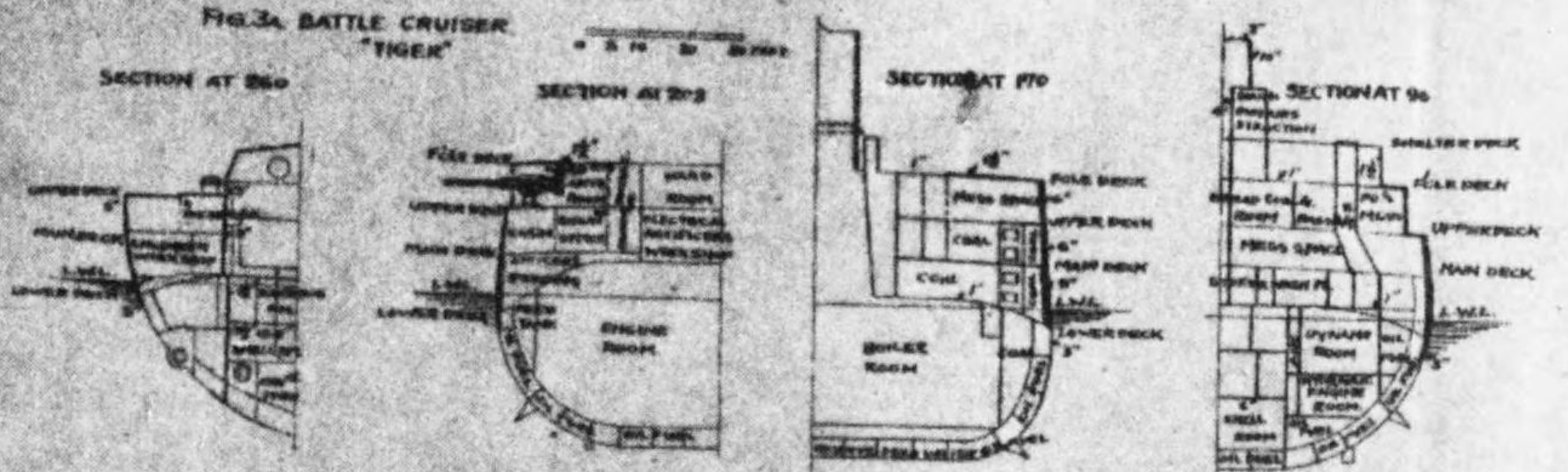

FIG. 3. BATTLE CRUISER 'TIGER'
LENGTH 500 FT.
BREADTH 70 FT.
DISPLACEMENT 13,700 TONS
DISPLACEMENT (BURIED) 15,000 TONS
SPEED 27.5 KNOTS
ARMAMENT TWO 12-IN. GUNS, ONE 6-IN. GUN, ONE 3-IN. GUN, ONE 2-IN. T. T.

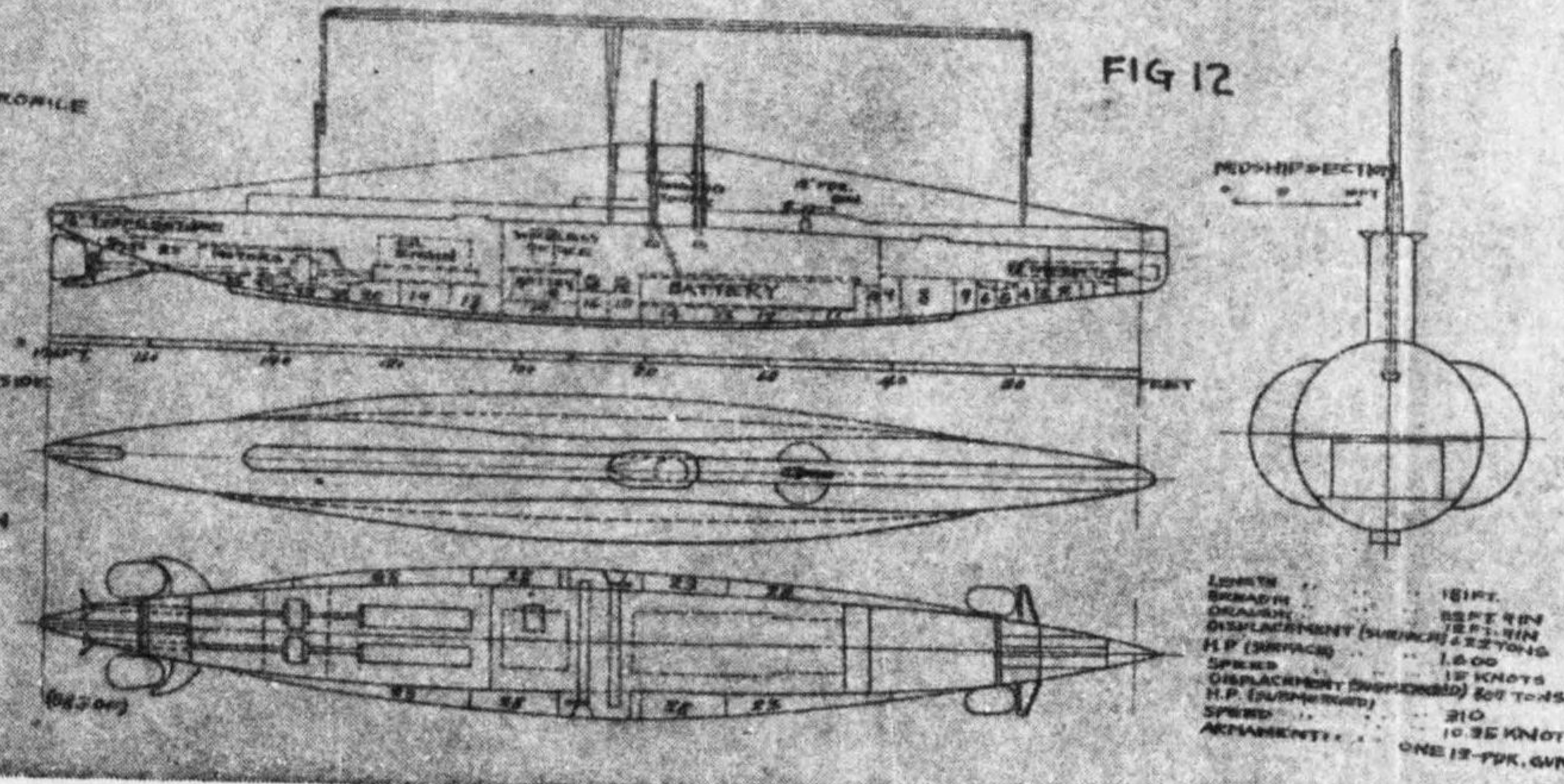
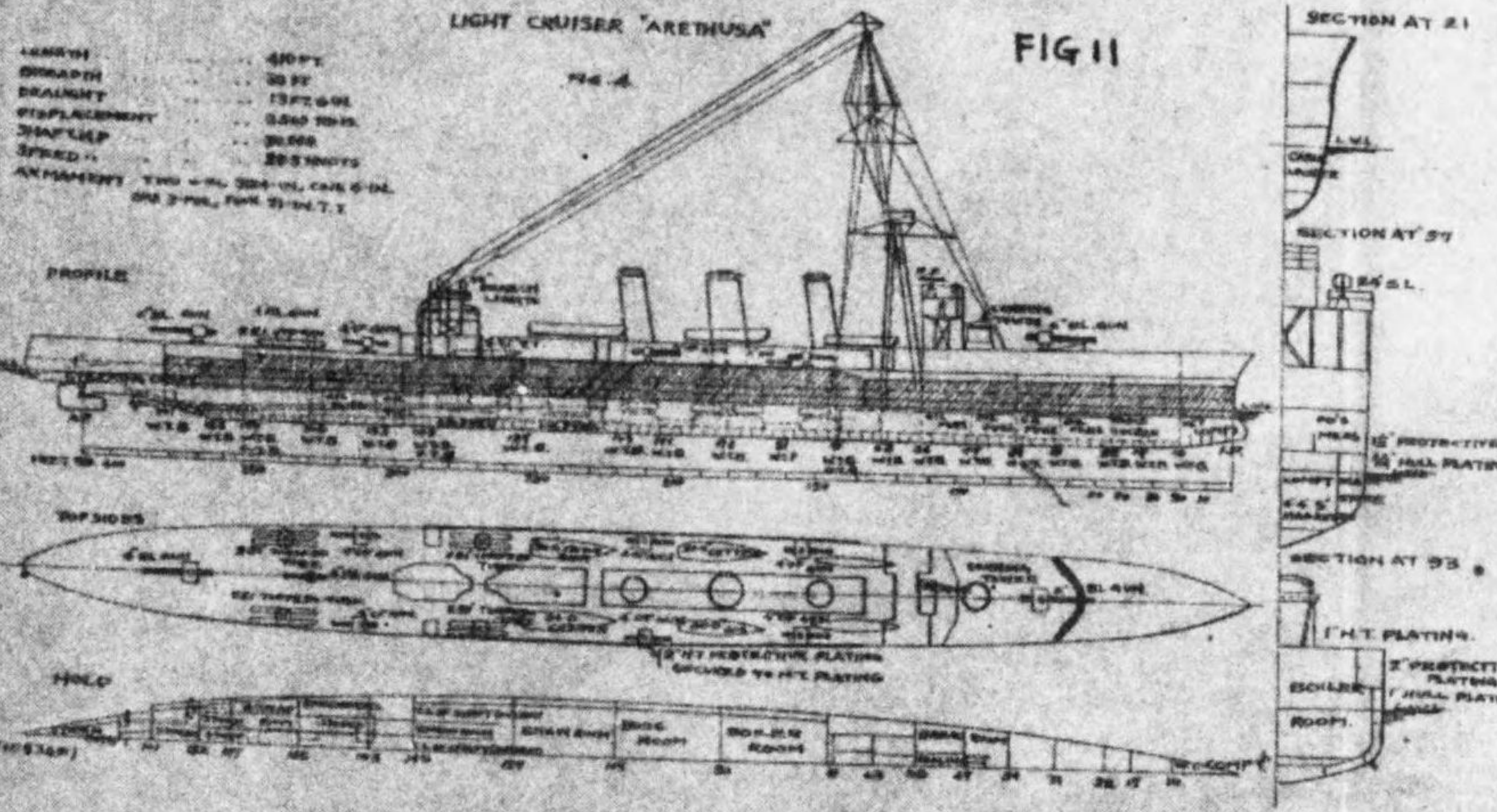

FIG. 12
LENGTH 181 FT.
BREADTH 28 FT. 6 IN.
DISPLACEMENT (BURIED) 15,000 TONS
DISPLACEMENT (SURFACE) 13,000 TONS
SPEED 17 KNOTS
DISPLACEMENT (SURFACE) 500 TONS
H.P. (SURFACE) 210
SPEED 10.5 KNOTS
ARMAMENT ONE 12-IN. GUN, ONE 6-IN. GUN, ONE 3-IN. GUN, ONE 2-IN. T. T.

NAME OF THE MASTERS NAVY ORDERED PRIOR TO THE

FIG. 13.

H.M.S. BATTLE CRUISER "HOOD."

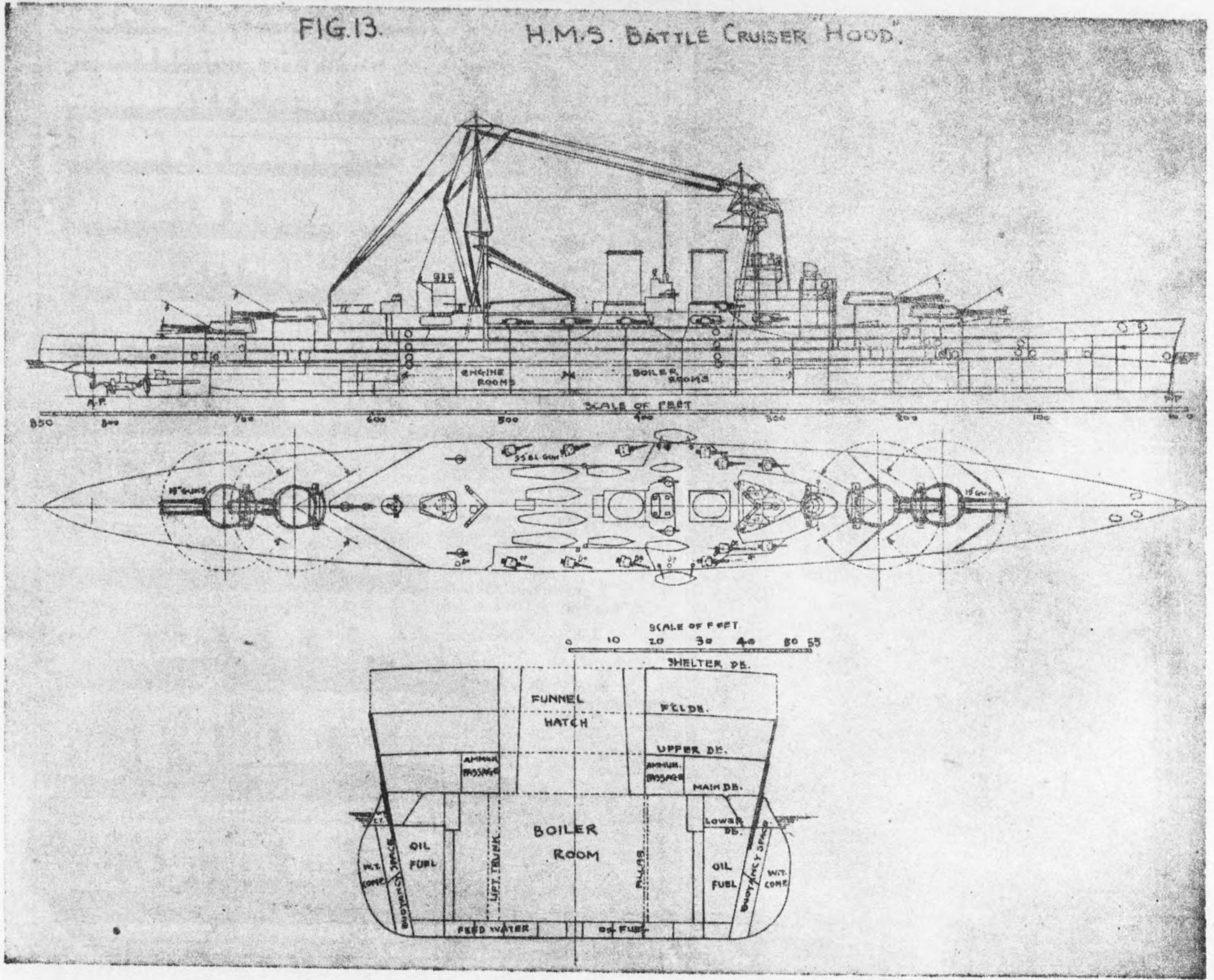
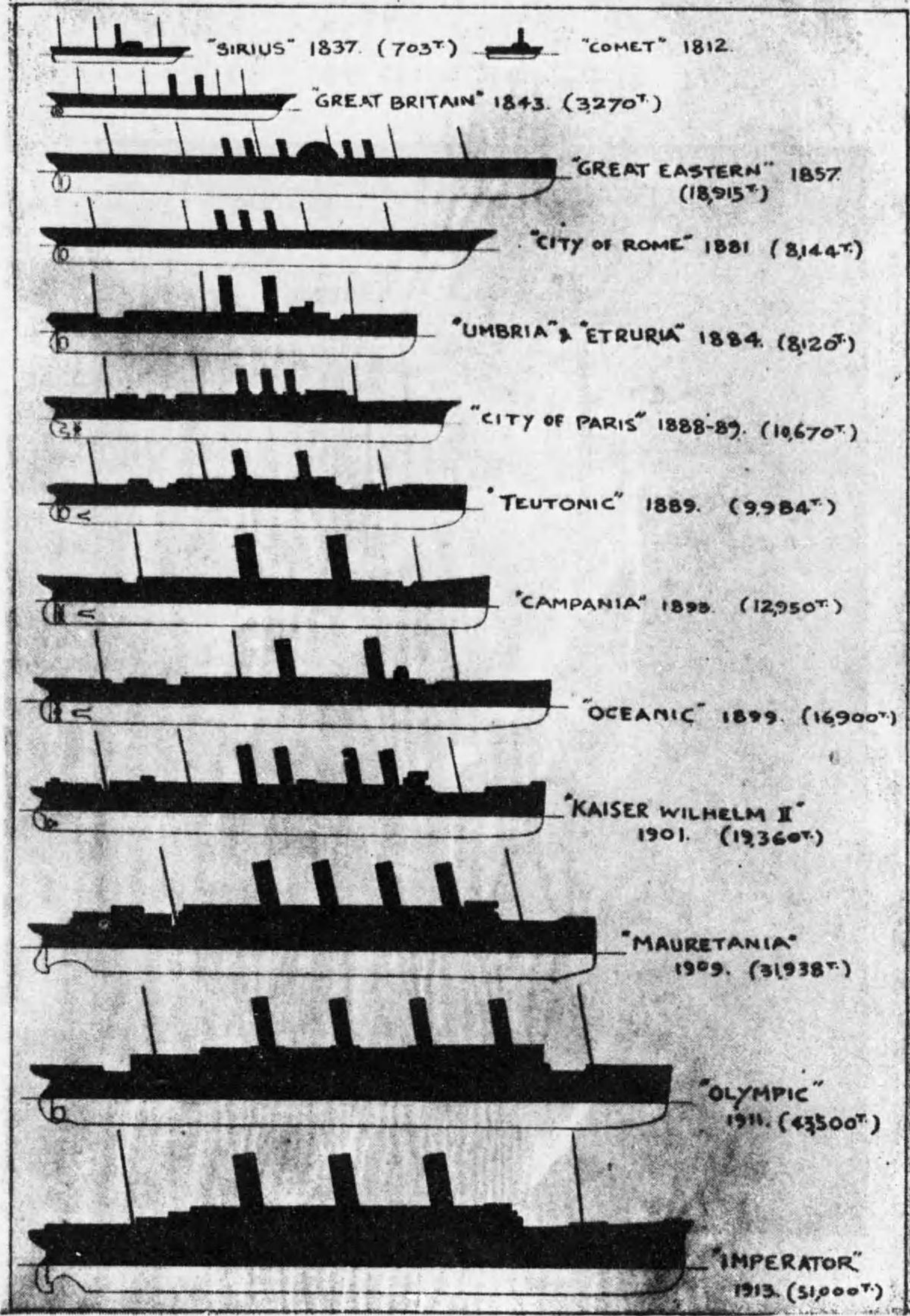
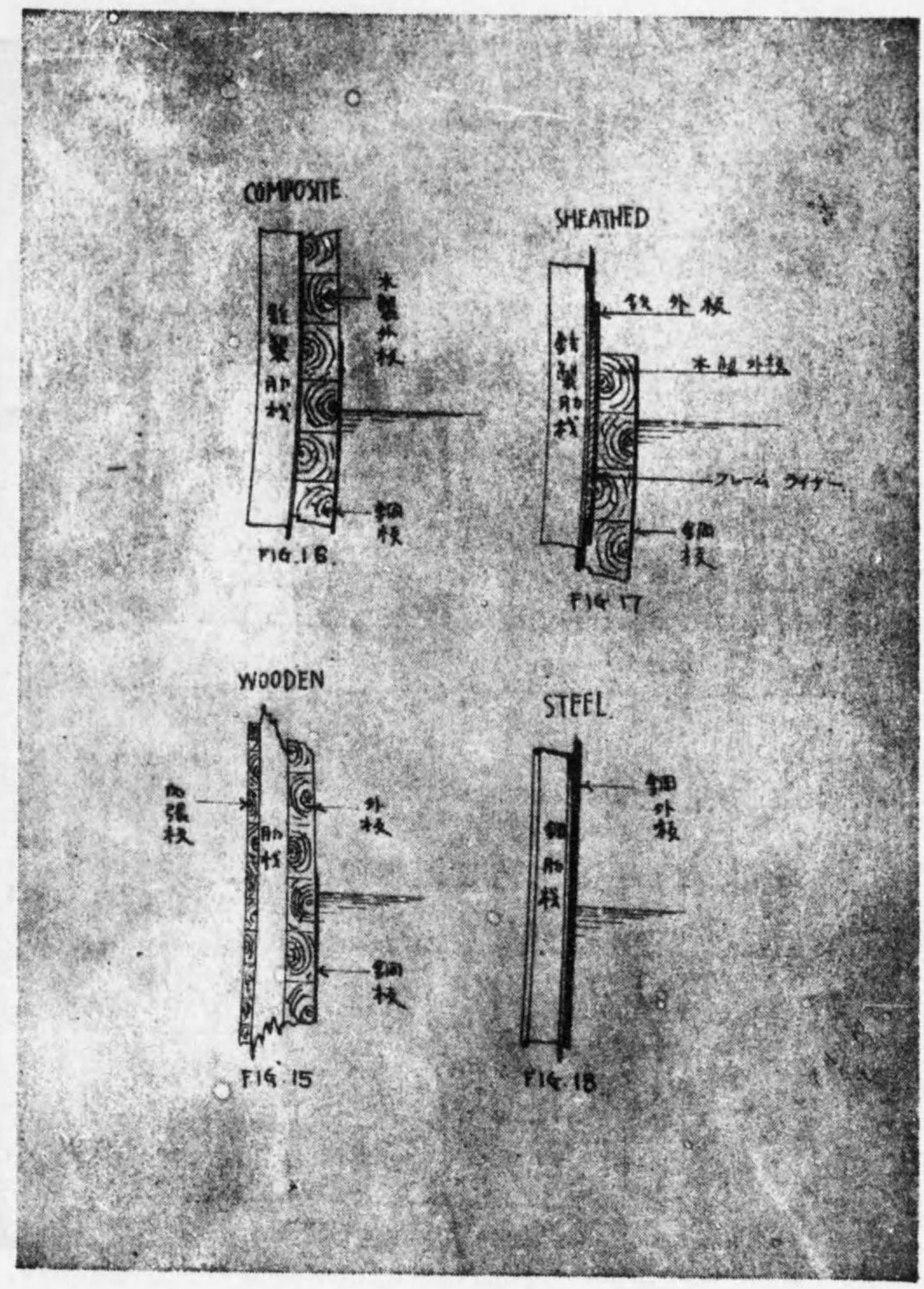

FIG. 14.



No. 212

1. 鋼筋混凝土 (Steel Reinforced Concrete)
 2. 鋼筋水泥 (Steel Reinforced Cement)
 3. 鋼筋磚 (Steel Reinforced Brick)
 4. 鋼筋木 (Steel Reinforced Wood)
 5. 鋼筋土 (Steel Reinforced Earth)
 6. 鋼筋石 (Steel Reinforced Stone)
 7. 鋼筋砂 (Steel Reinforced Sand)
 8. 鋼筋灰 (Steel Reinforced Ash)
 9. 鋼筋渣 (Steel Reinforced Slag)
 10. 鋼筋粉 (Steel Reinforced Powder)
 11. 鋼筋泥 (Steel Reinforced Mud)
 12. 鋼筋油 (Steel Reinforced Oil)
 13. 鋼筋水 (Steel Reinforced Water)
 14. 鋼筋氣 (Steel Reinforced Gas)
 15. 鋼筋電 (Steel Reinforced Electricity)
 16. 鋼筋磁 (Steel Reinforced Magnetism)
 17. 鋼筋熱 (Steel Reinforced Heat)
 18. 鋼筋光 (Steel Reinforced Light)
 19. 鋼筋力 (Steel Reinforced Force)
 20. 鋼筋能 (Steel Reinforced Energy)



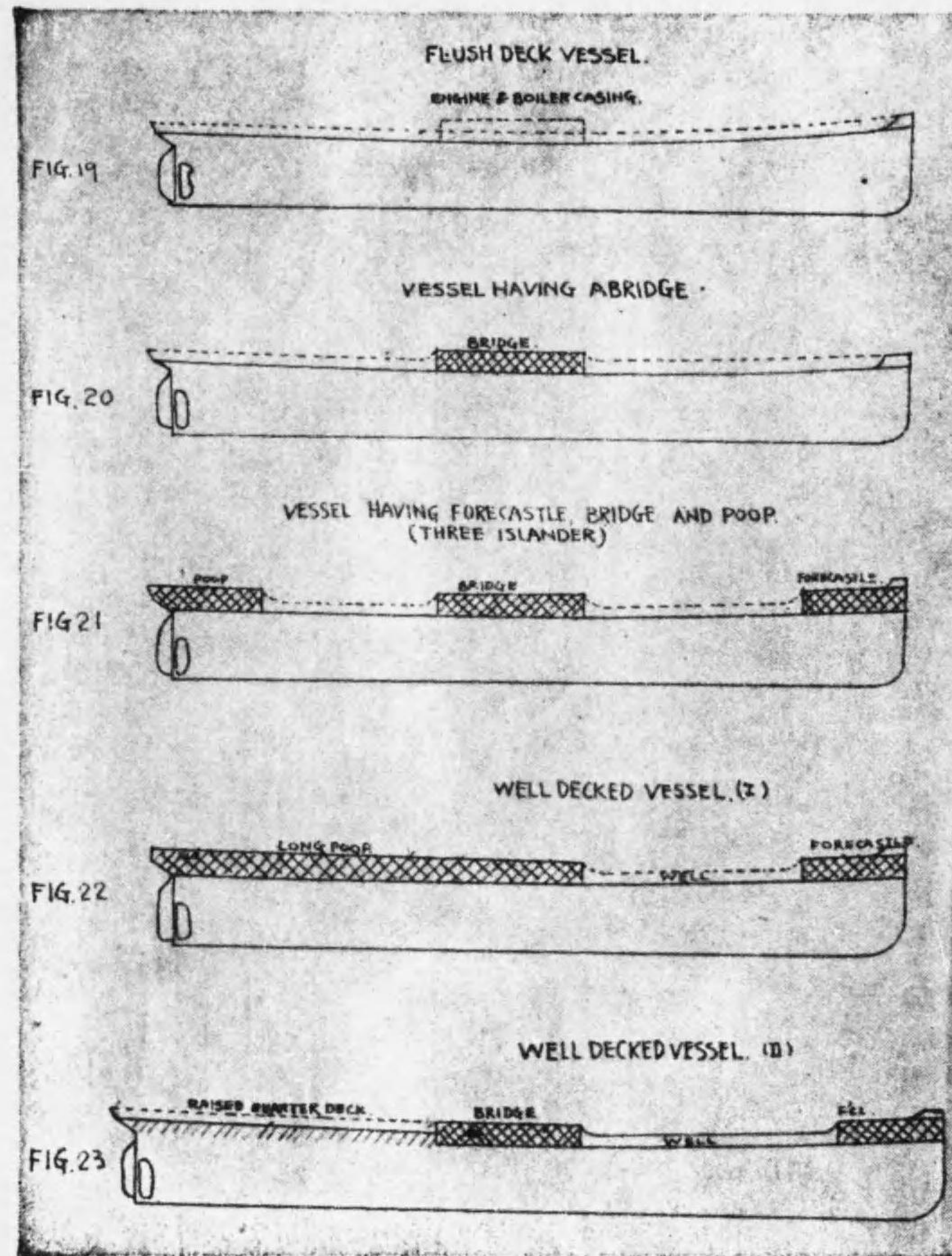
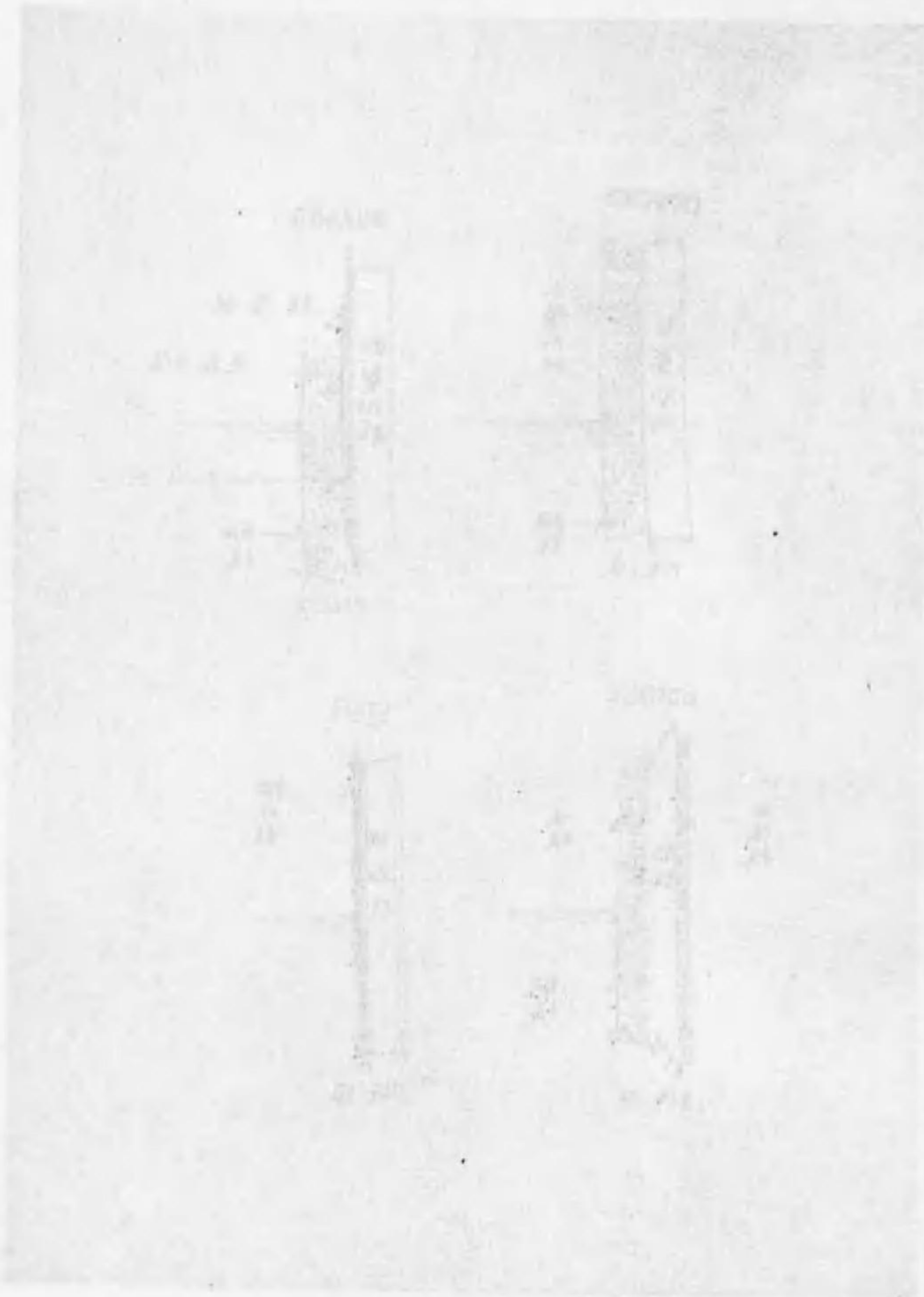



WELL DECKED VESSEL. (III)

FIG. 24



PART AWNING DECK VESSEL. (I)

FIG. 25



PART AWNING DECK VESSEL. (II)

FIG. 26



VESSEL HAVING FORECASTLE, LONG BRIDGE, AND POOP

FIG. 27

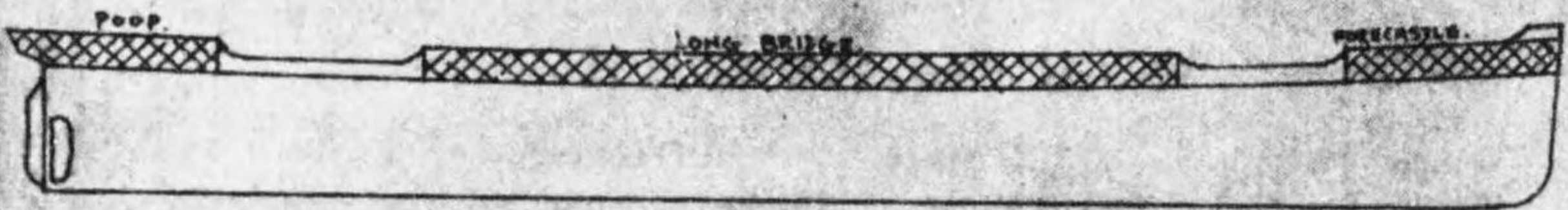

(SHADE DECK VESSEL.)
COMPLETE SUPER-STRUCTURE VESSEL. (IX)

FIG. 28



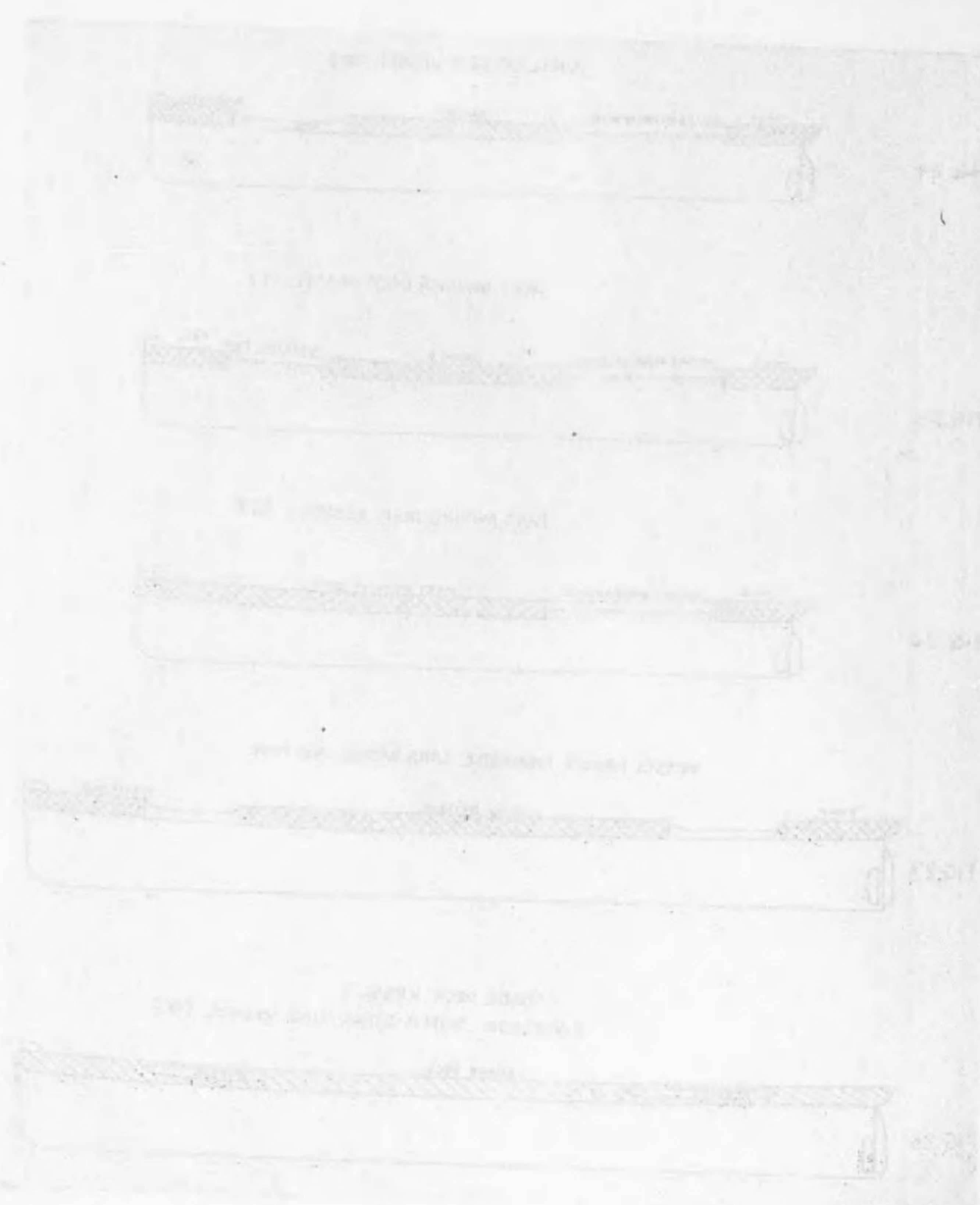

COMPLETE SUPER-STRUCTURE VESSEL (X)

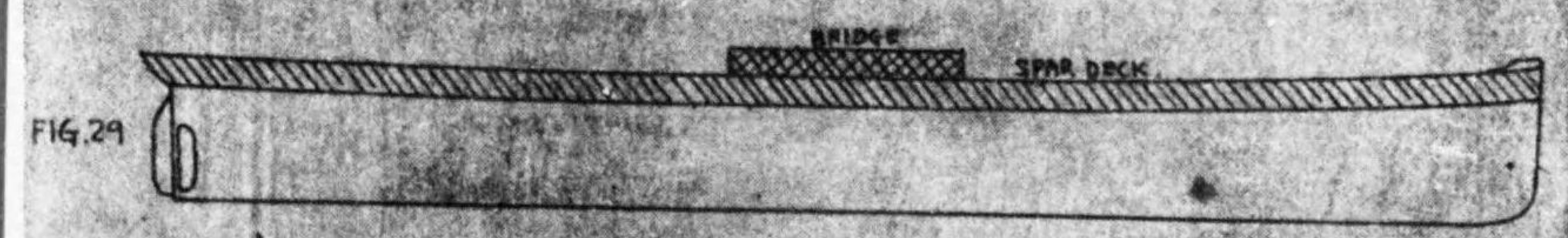

COMPLETE SUPER-STRUCTURE VESSEL (X)

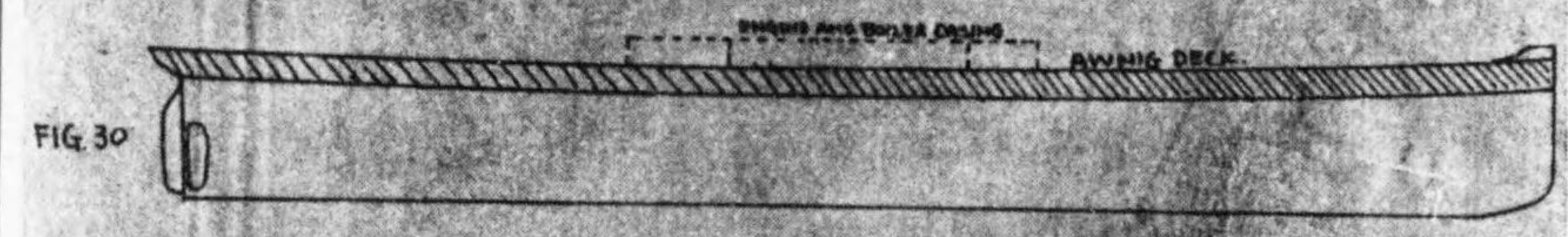

COMPLETE SUPER-STRUCTURE VESSEL (B)

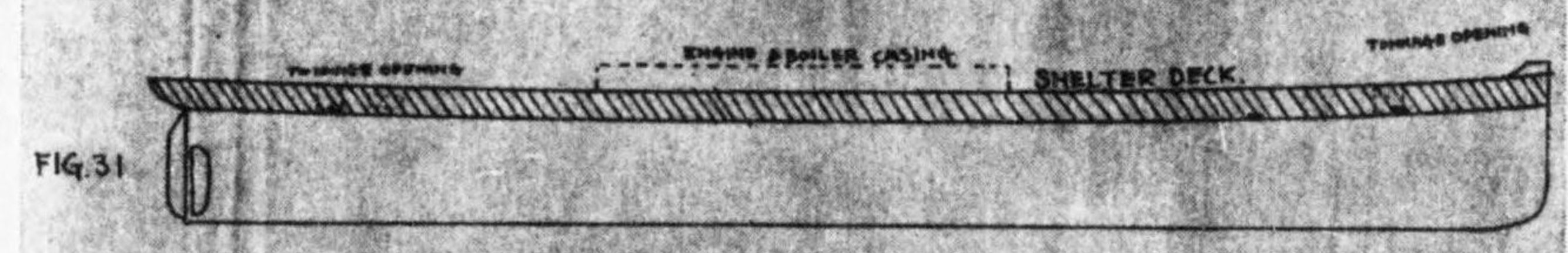

TURRET DECK VESSEL

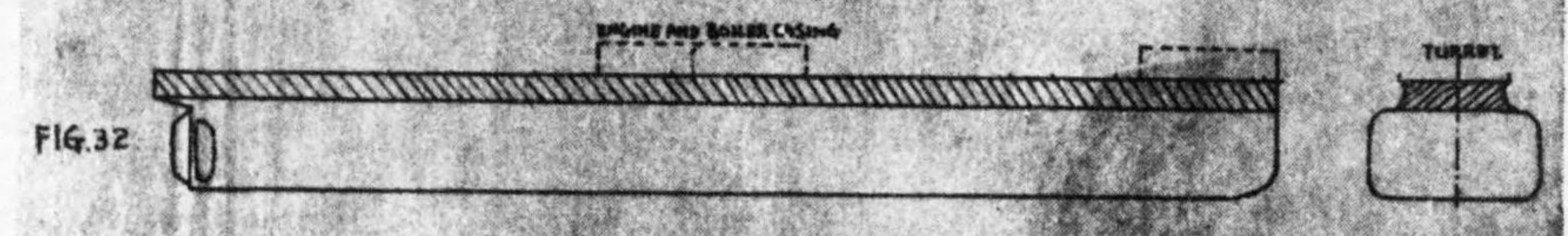

TRUNK DECK VESSEL

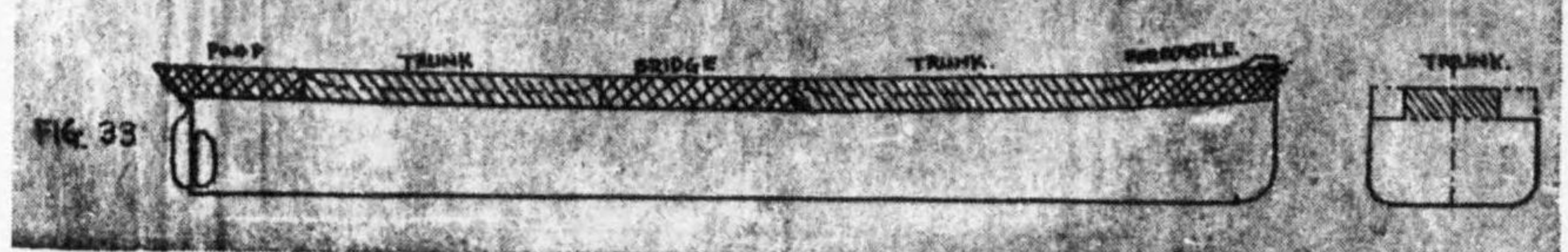

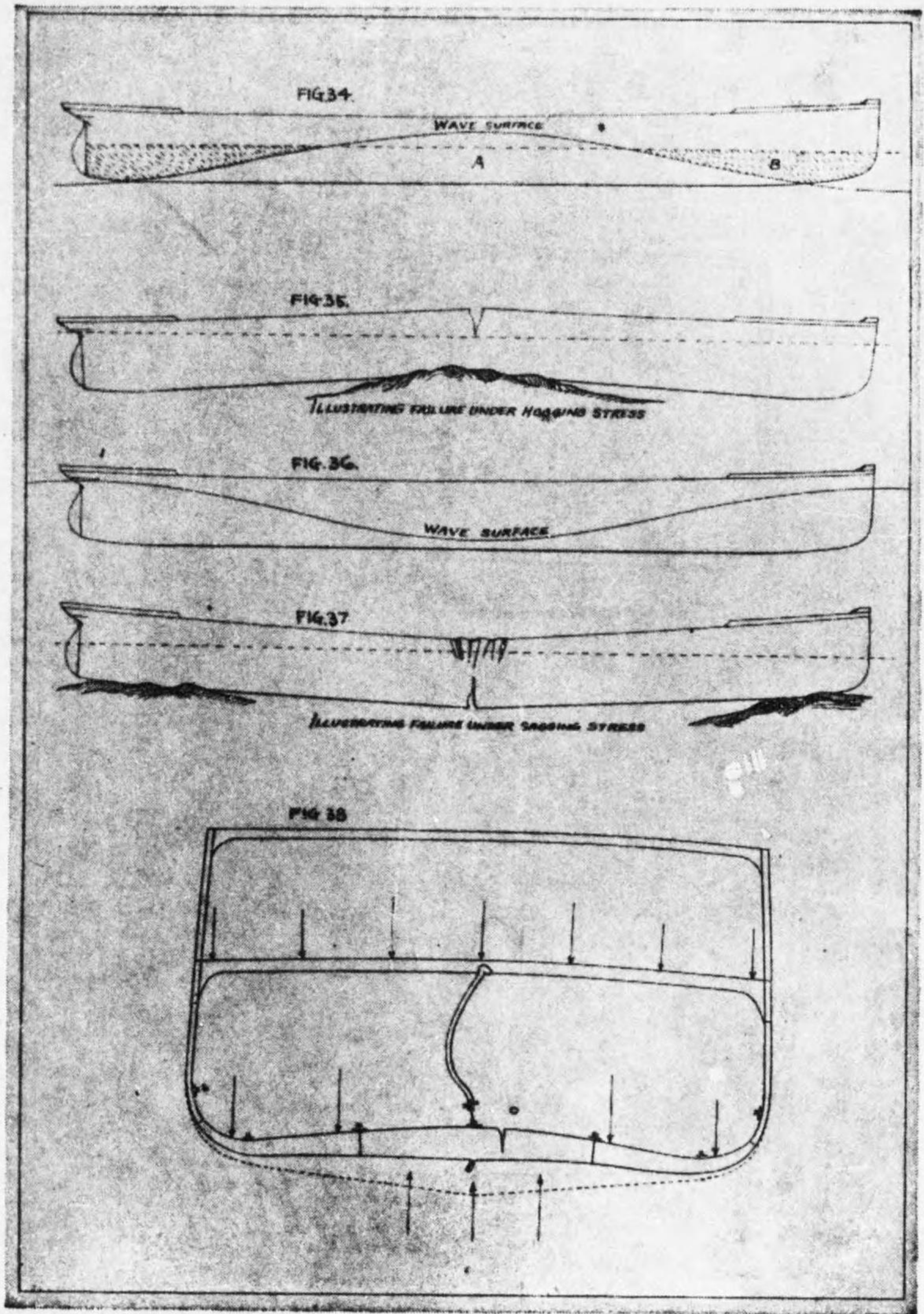
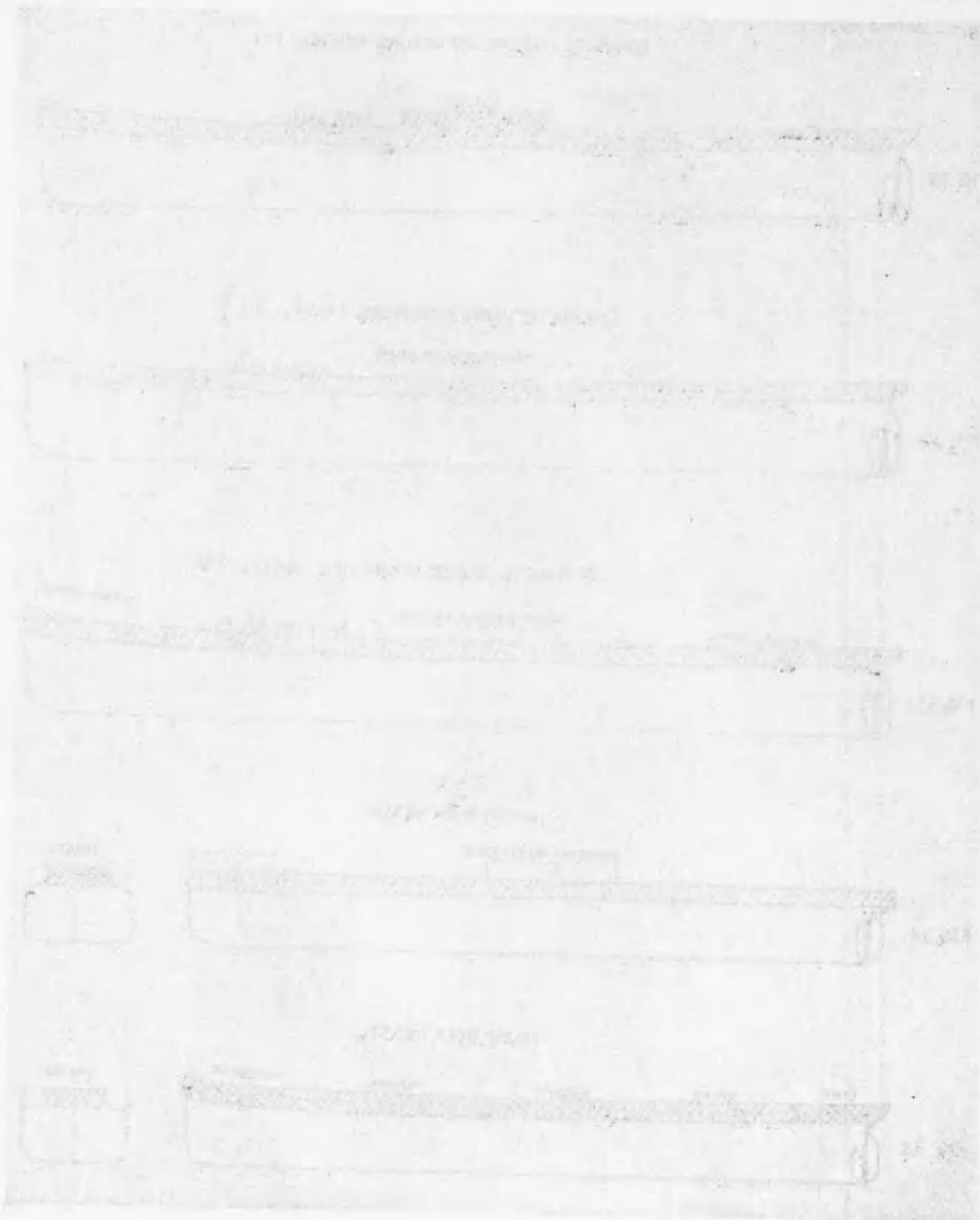

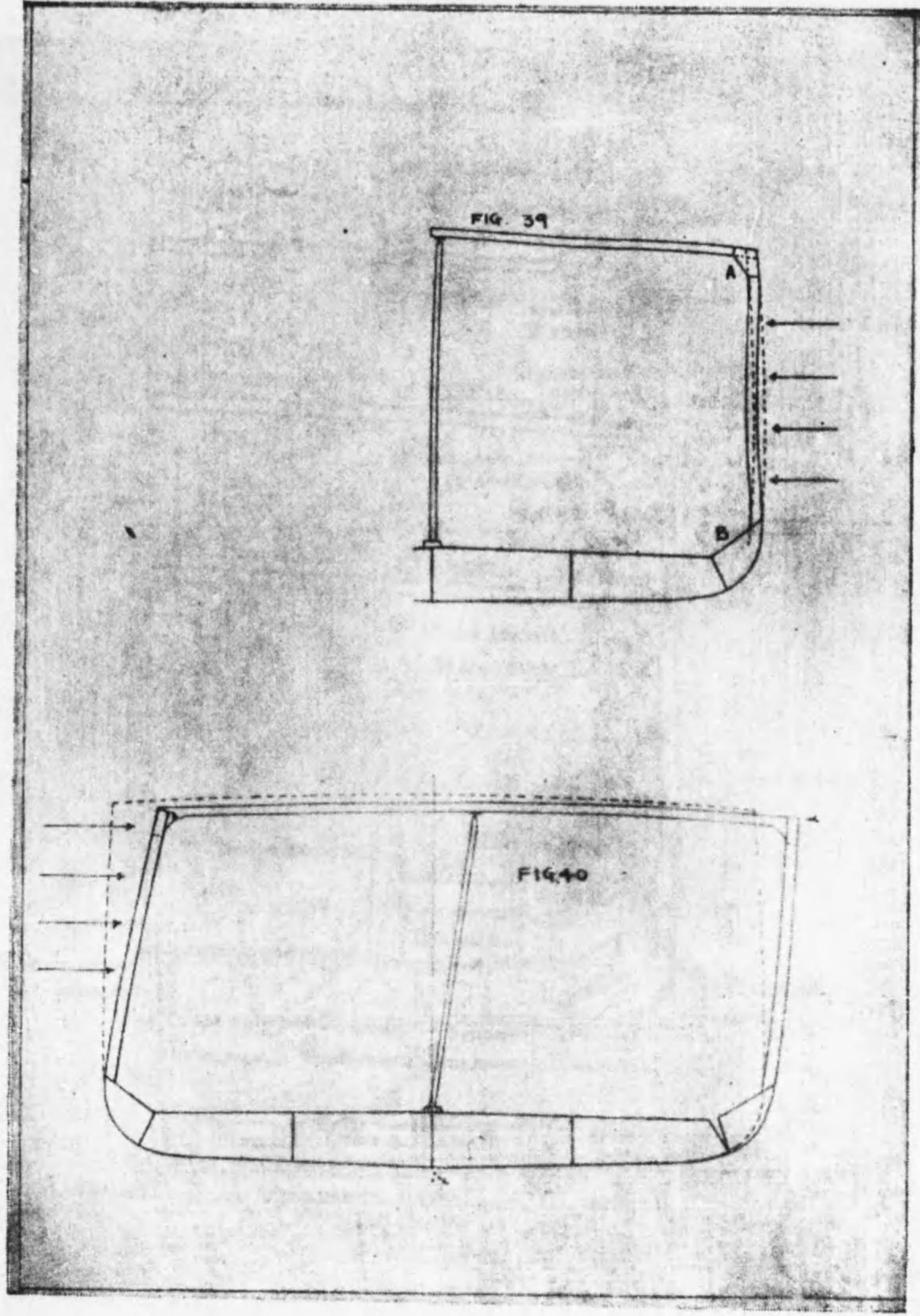
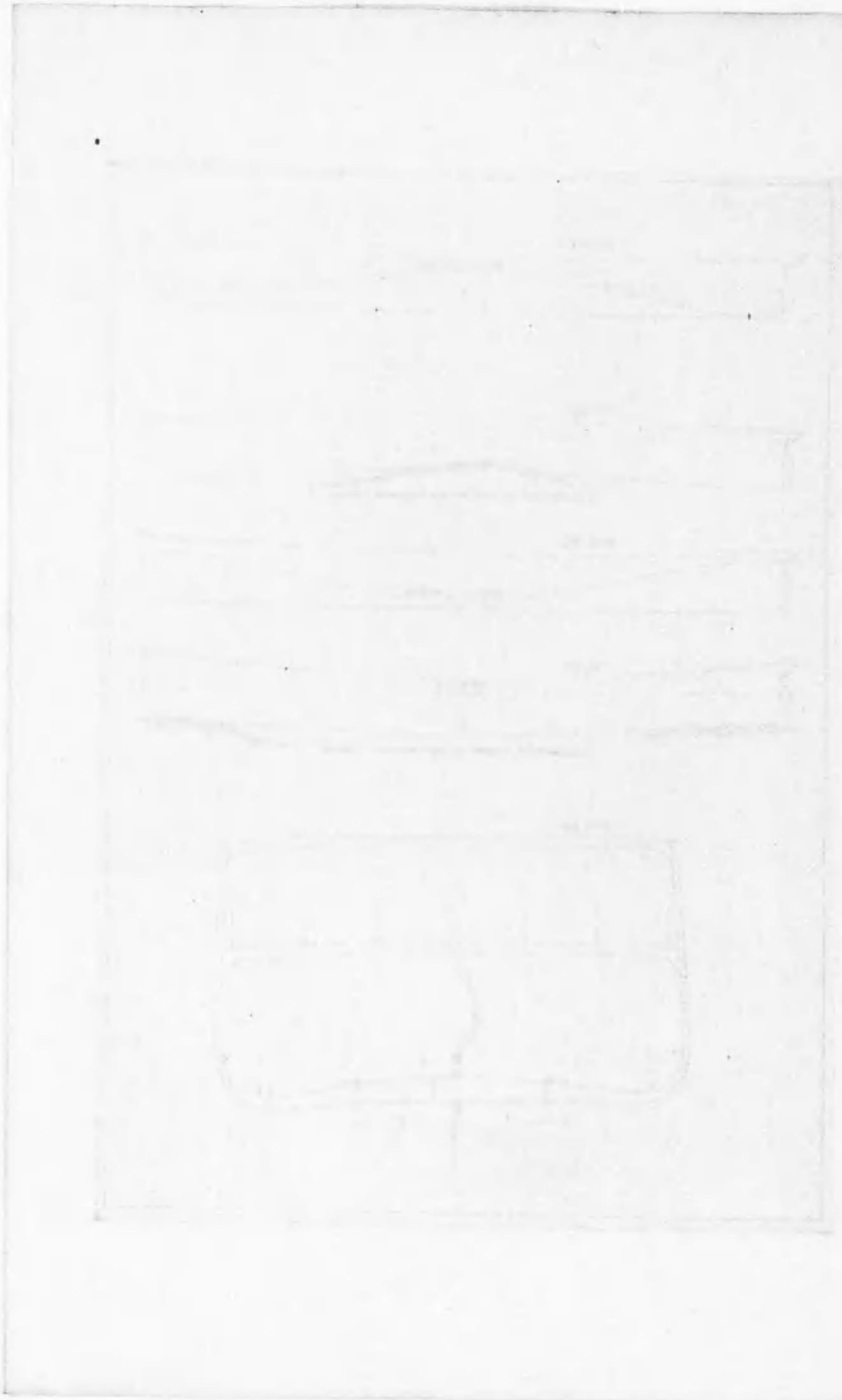

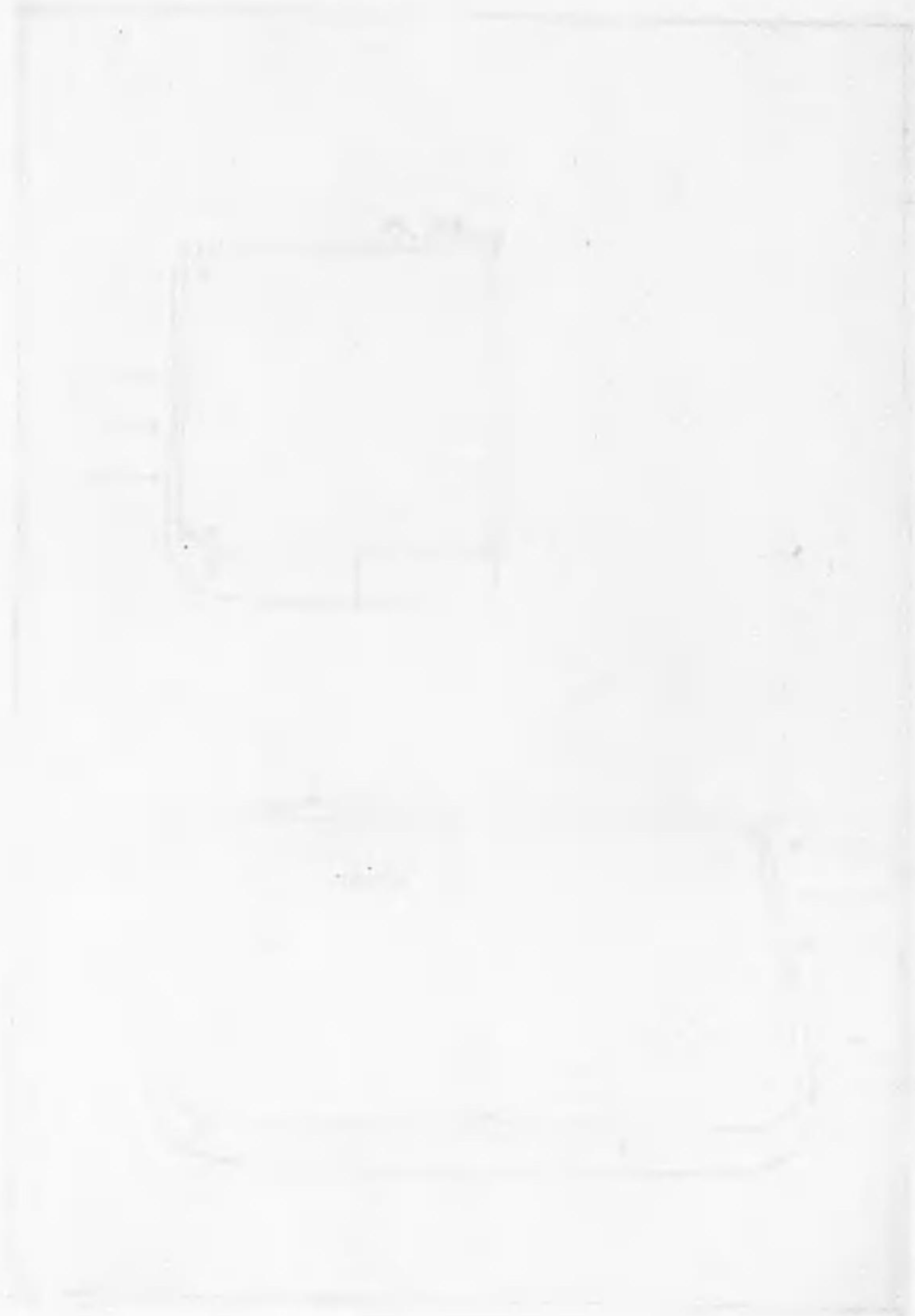

MIDSHIP SECTION OF A CARGO SHIP

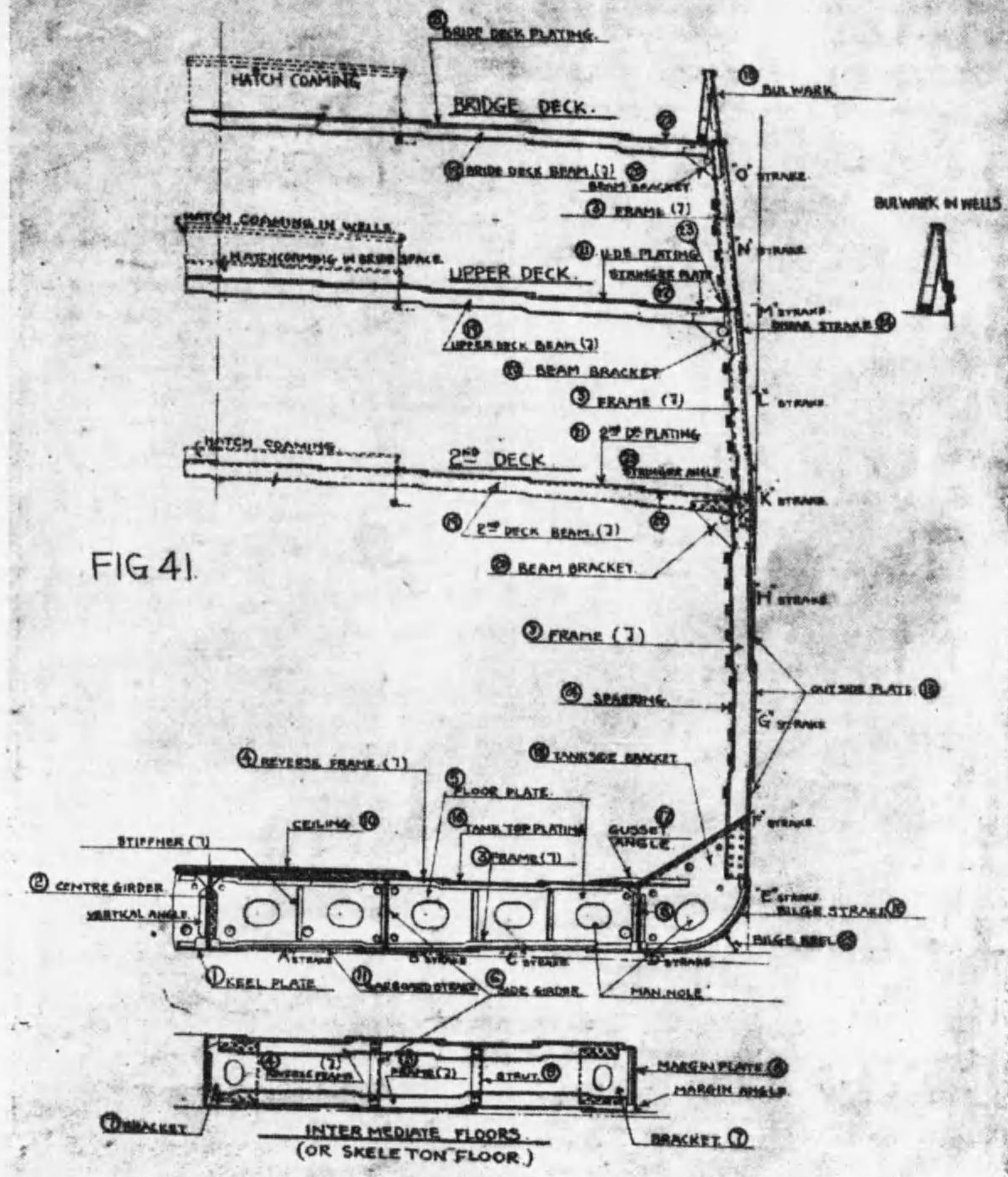

FIG 41

MIDSHIP-SECTION OF A WARSHIP.

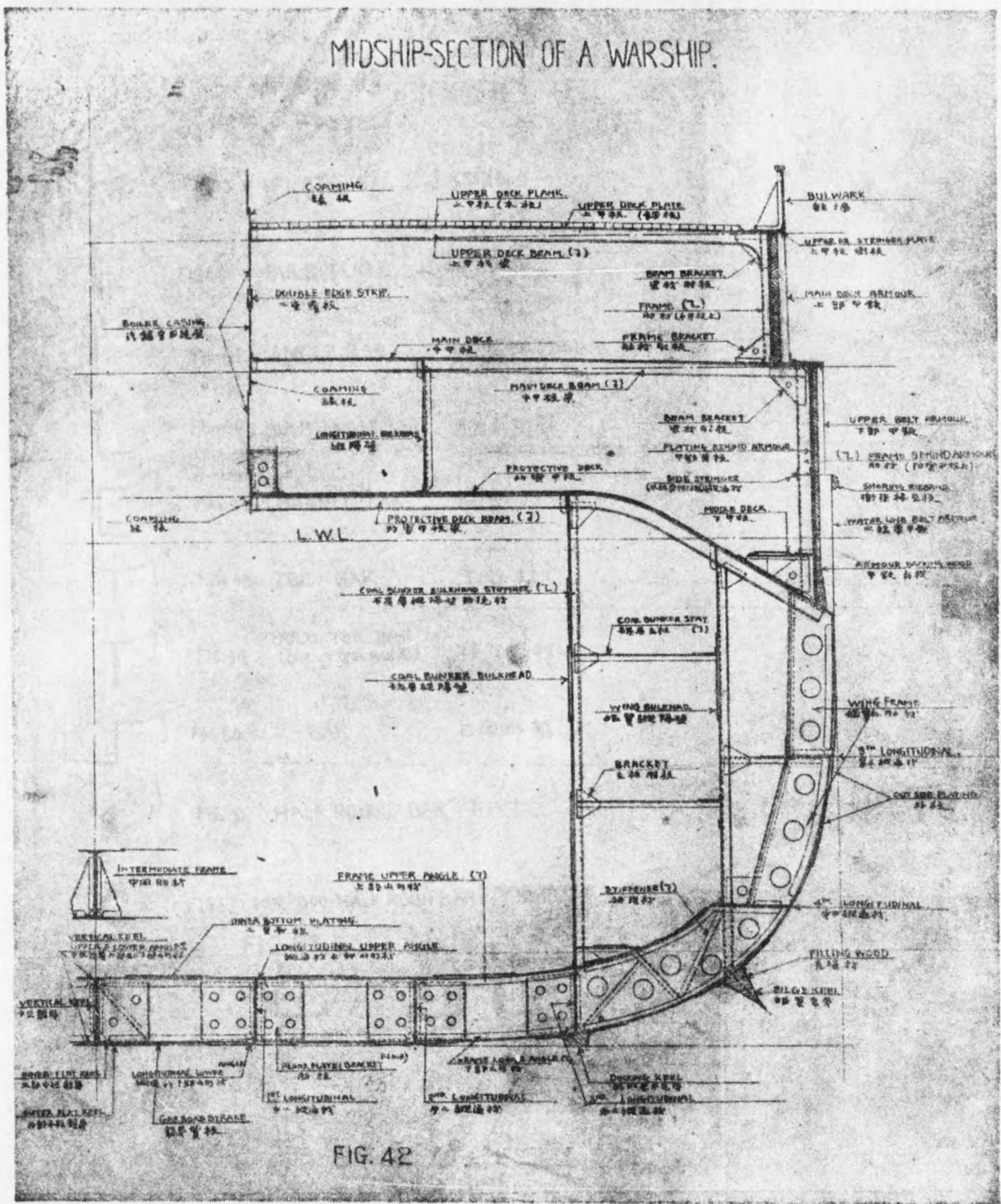

FIG. 42



FIG. 43. PLATE.

鋼板



FIG. 44. BULB PLATE.

球鋼板



FIG. 45. ANGLE BAR.

山形棧(鋼)



FIG. 46. BULB ANGLE BAR.

球山形棧



FIG. 47. CHANNEL BAR.

溝形棧



FIG. 48. TEE BAR.

丁形棧



FIG. 49. BULB TEE BAR (OR TEE BULB).

球丁形棧



FIG. 50. Z-BAR

乙字形棧



FIG. 51. HALF ROUND BAR

半圓棧



FIG. 52. HOLLOW HALF ROUND BAR

中空半圓棧

HATCH REST BAR (OR HATCH BAR).



1.

FIG. 53. TYZACK.



2.

CONVEX (OR COPE) PATENT MOULDING.



3.

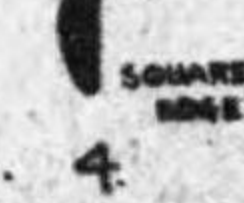

4.

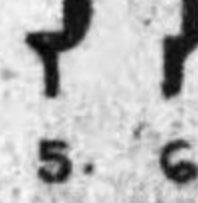

5.

6.

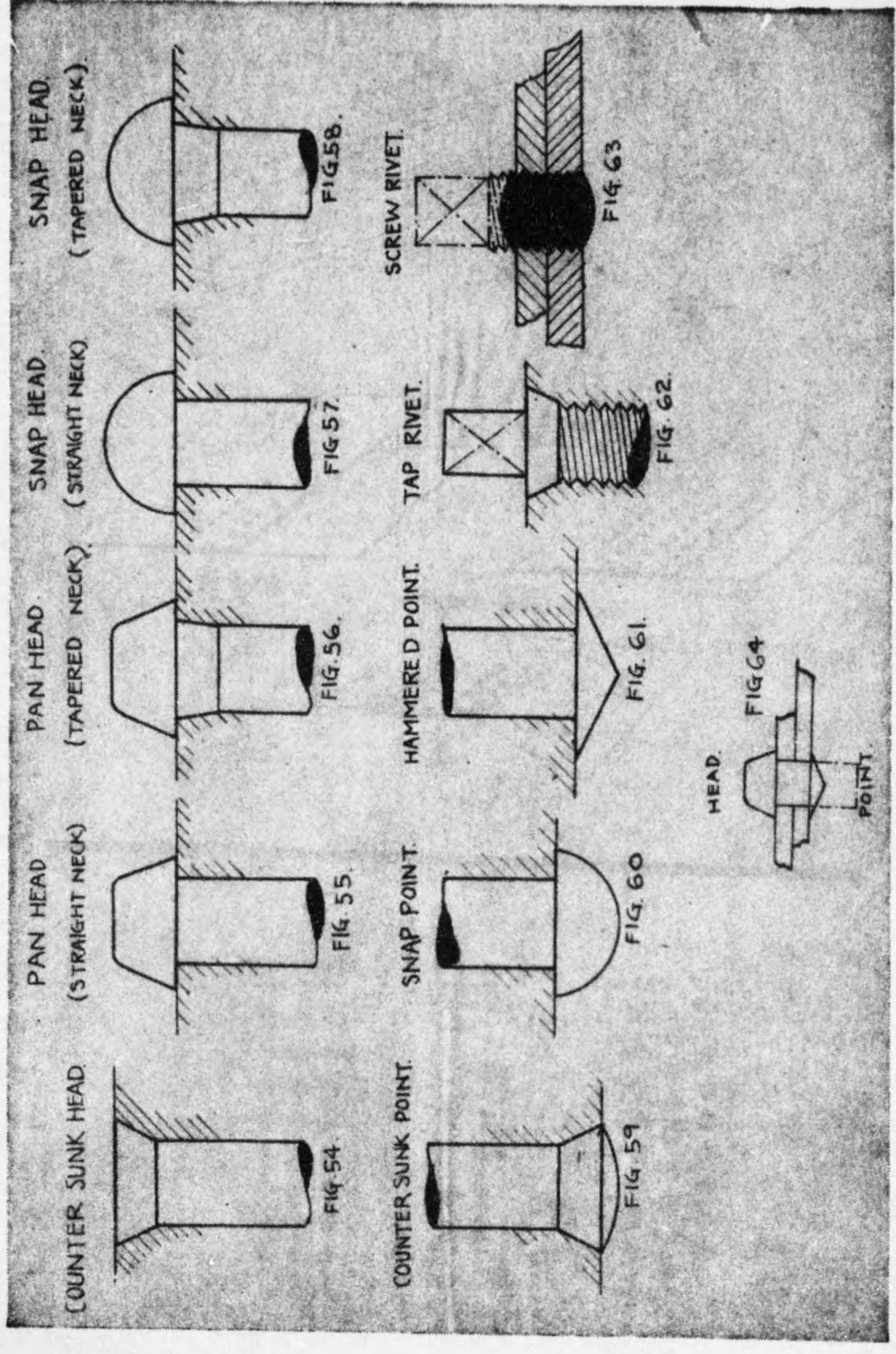
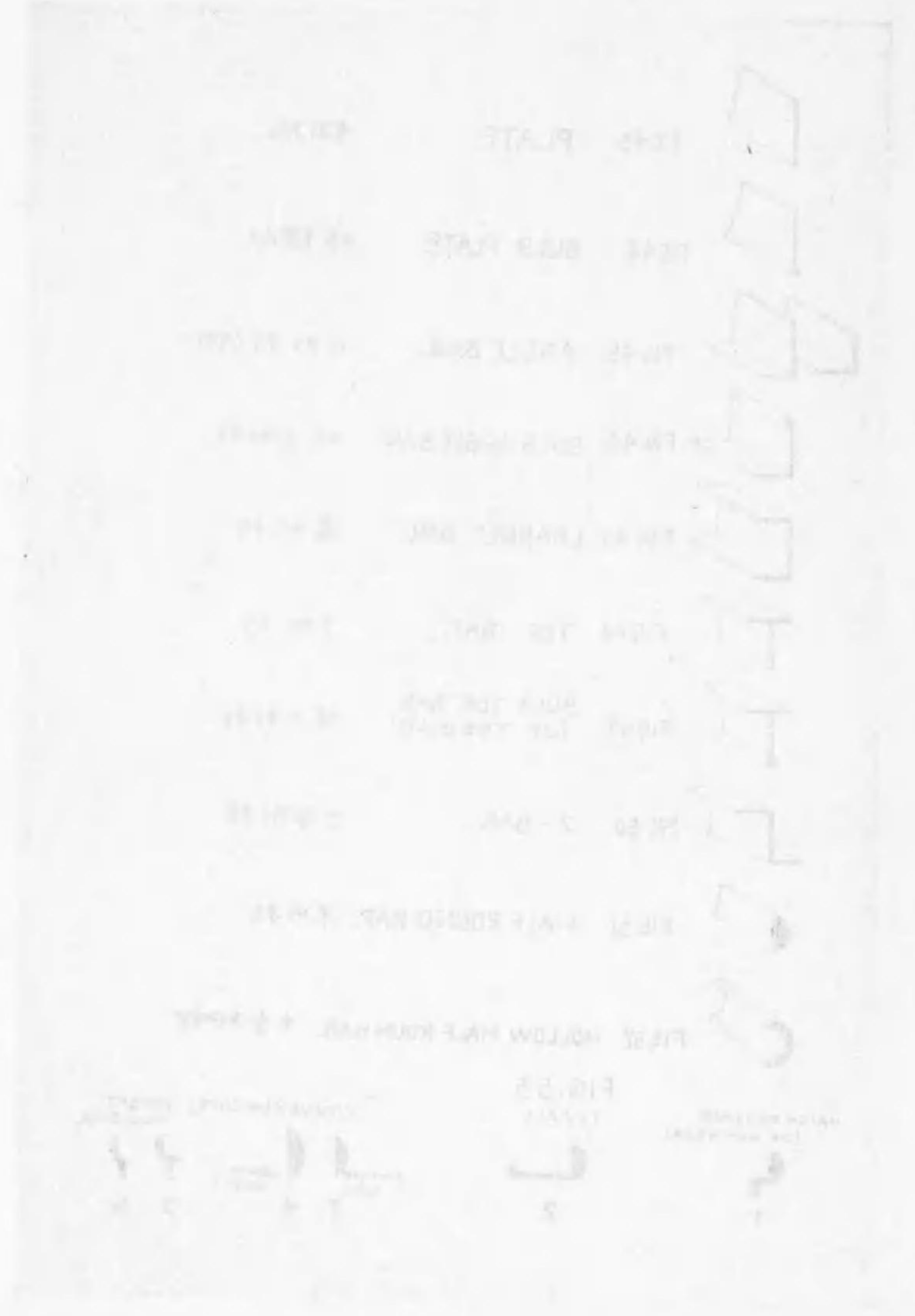

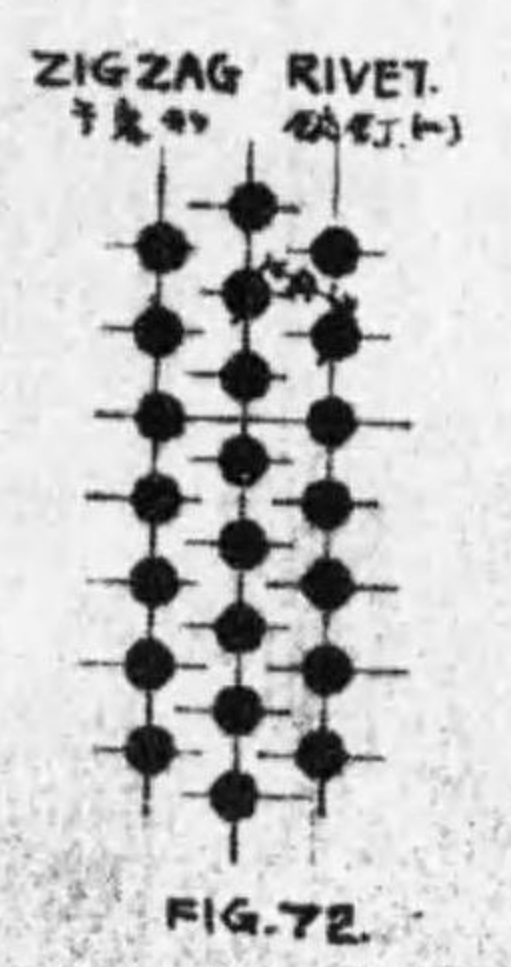
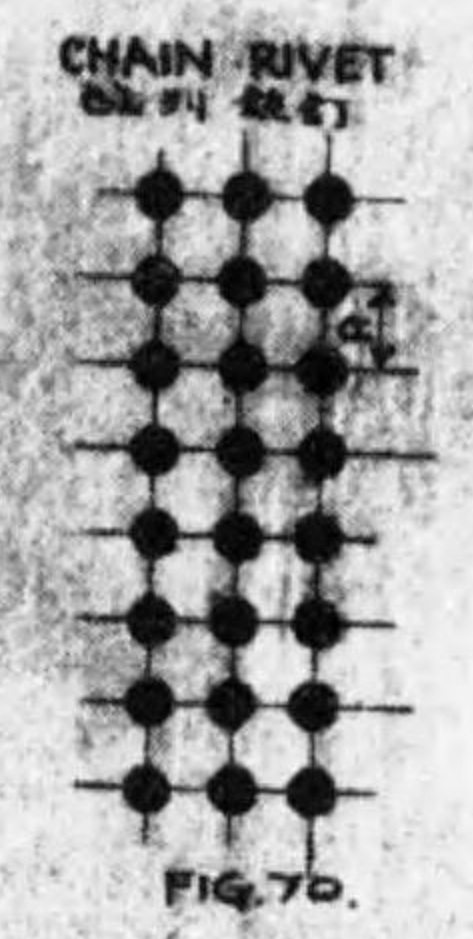
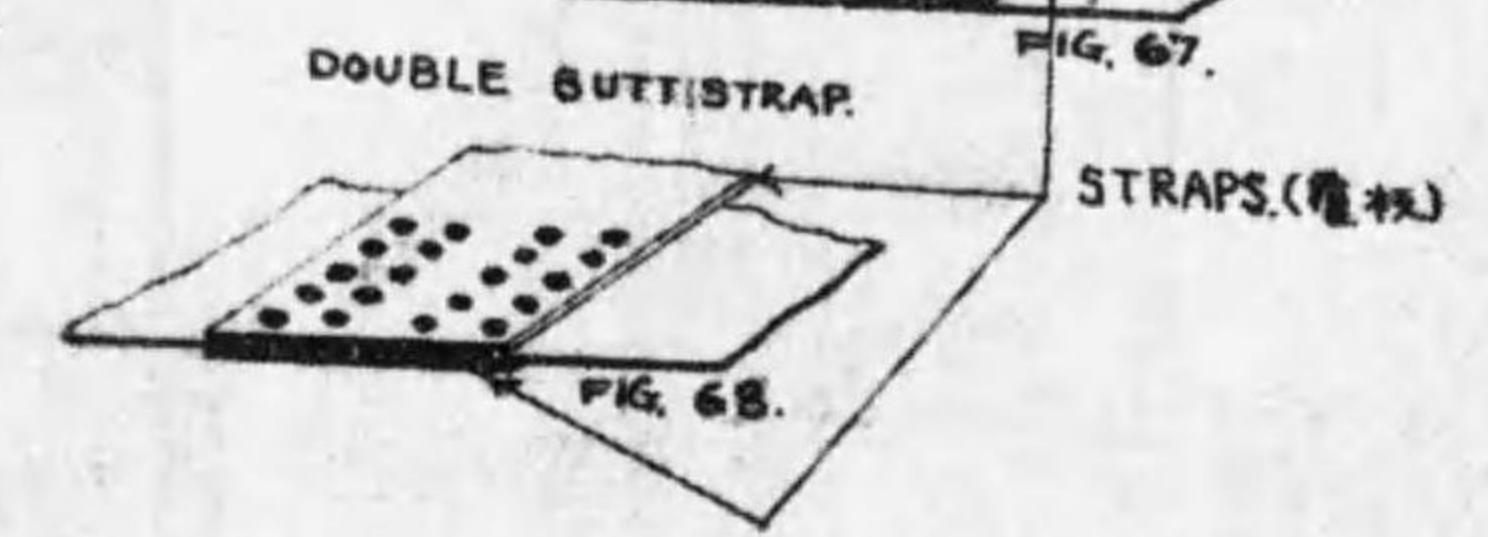
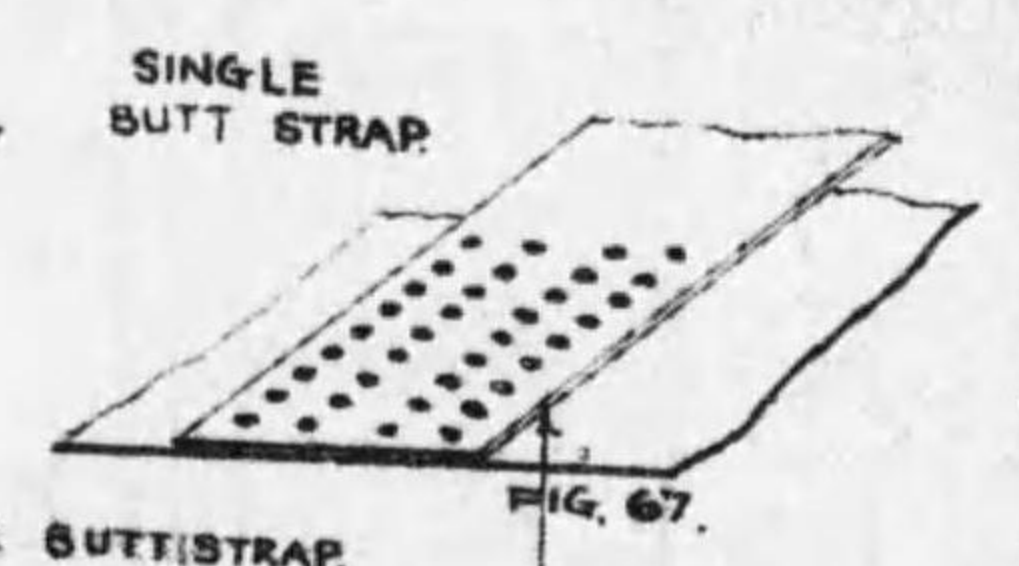
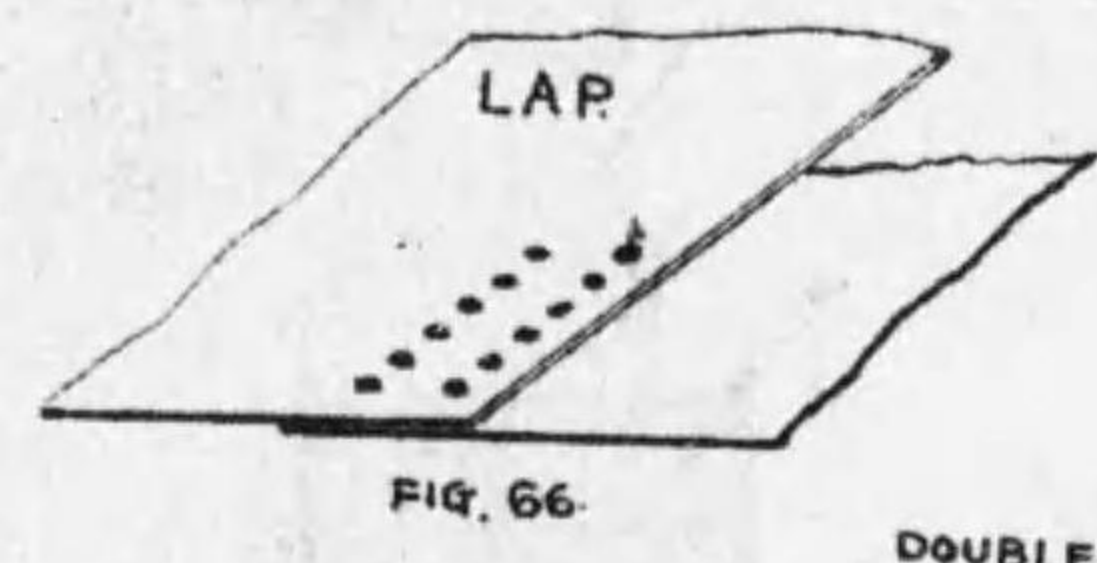
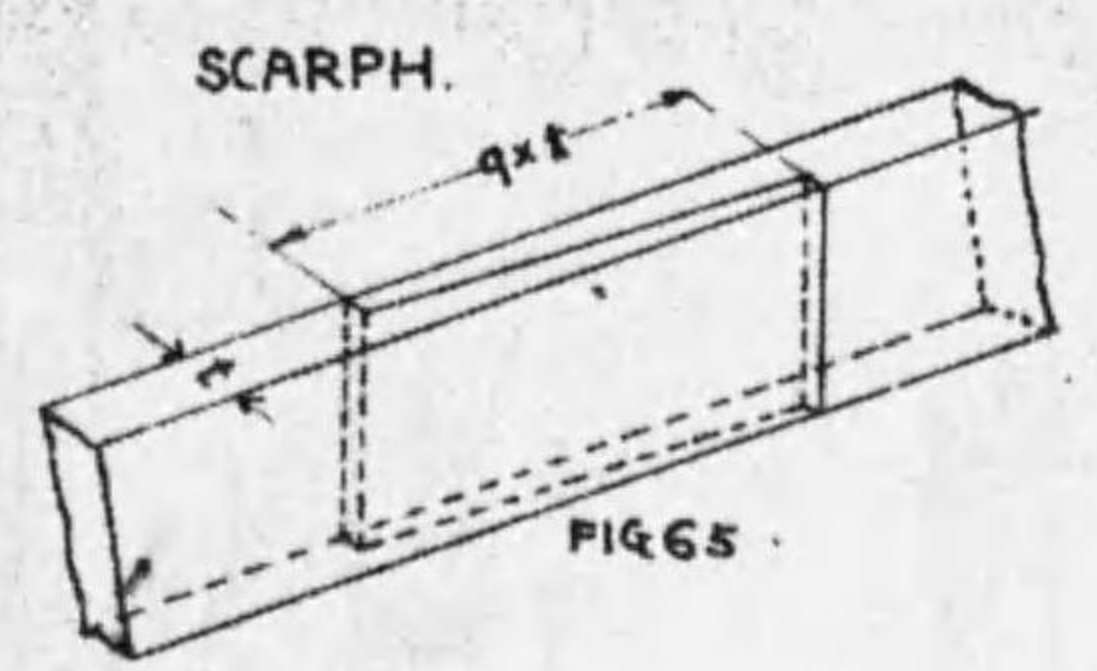

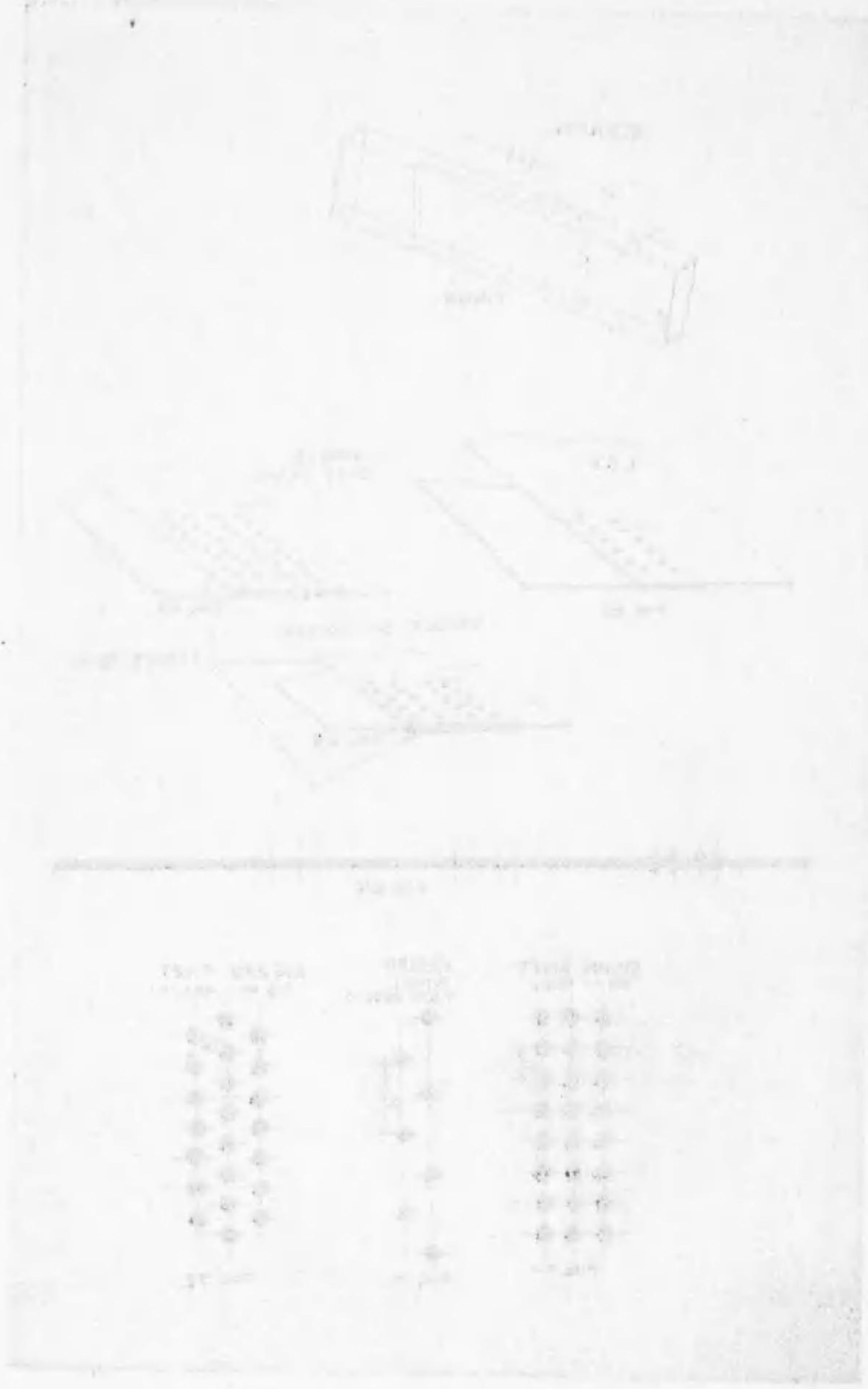

SINGLE BOTTOM CONSTRUCTION.

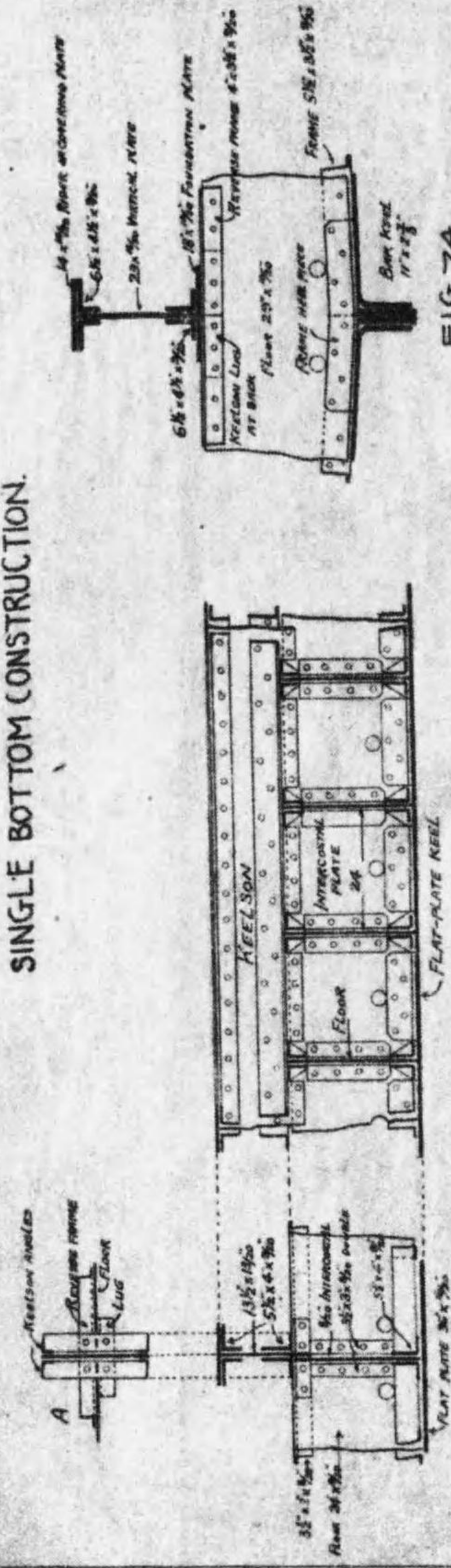

FIG. 73.

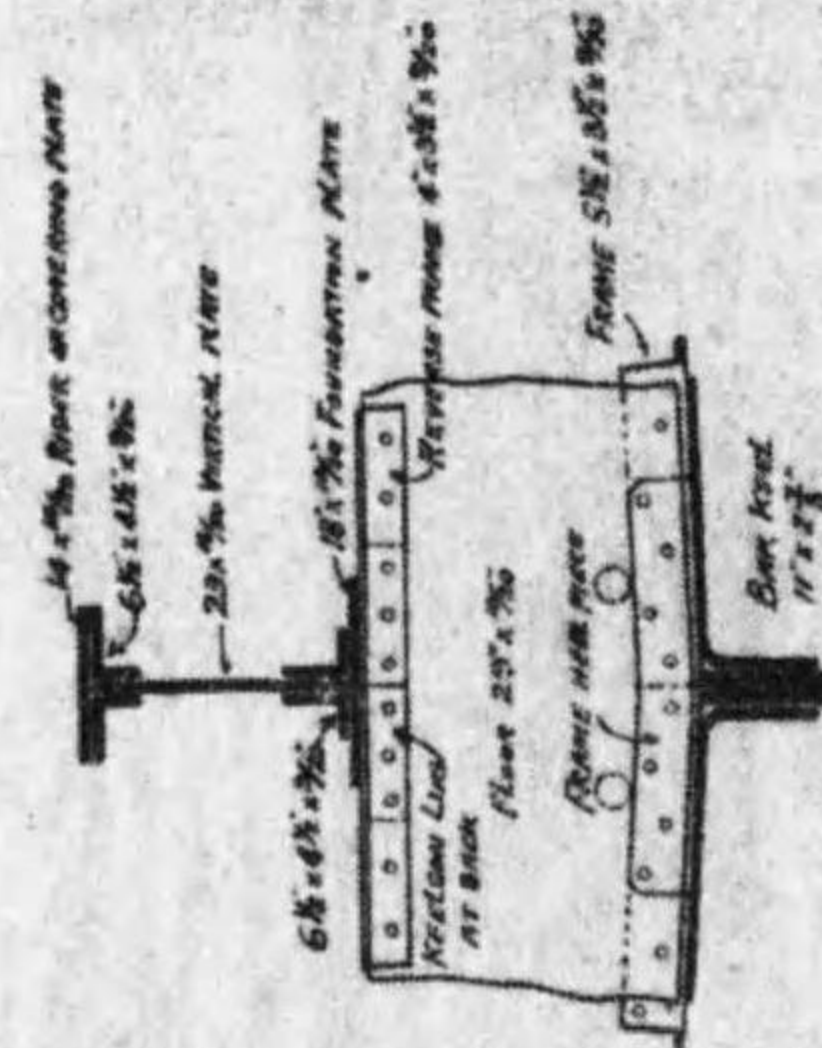

FIG. 74.

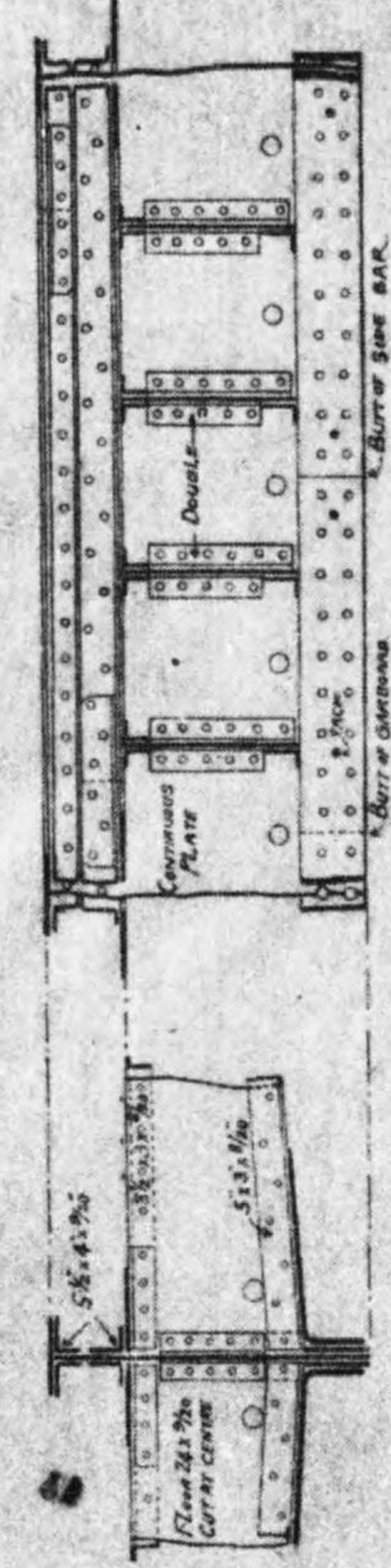
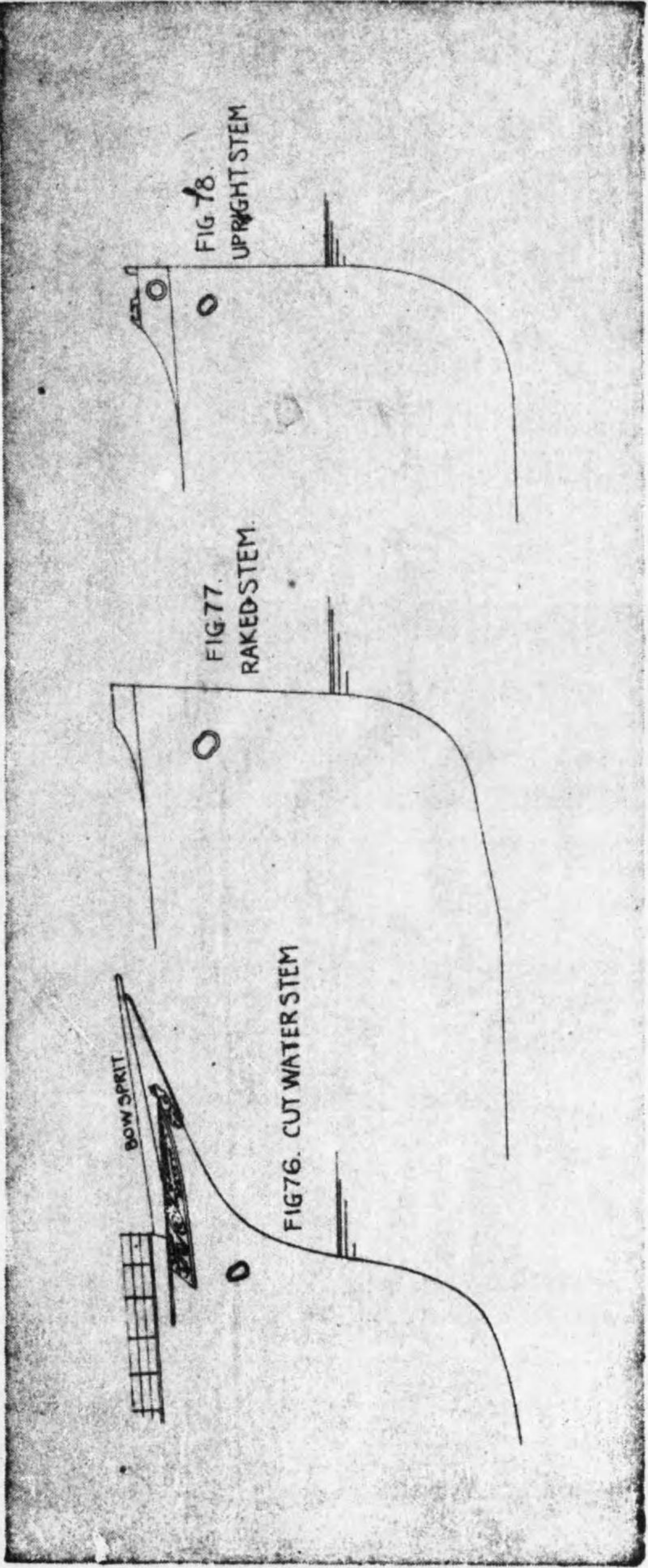
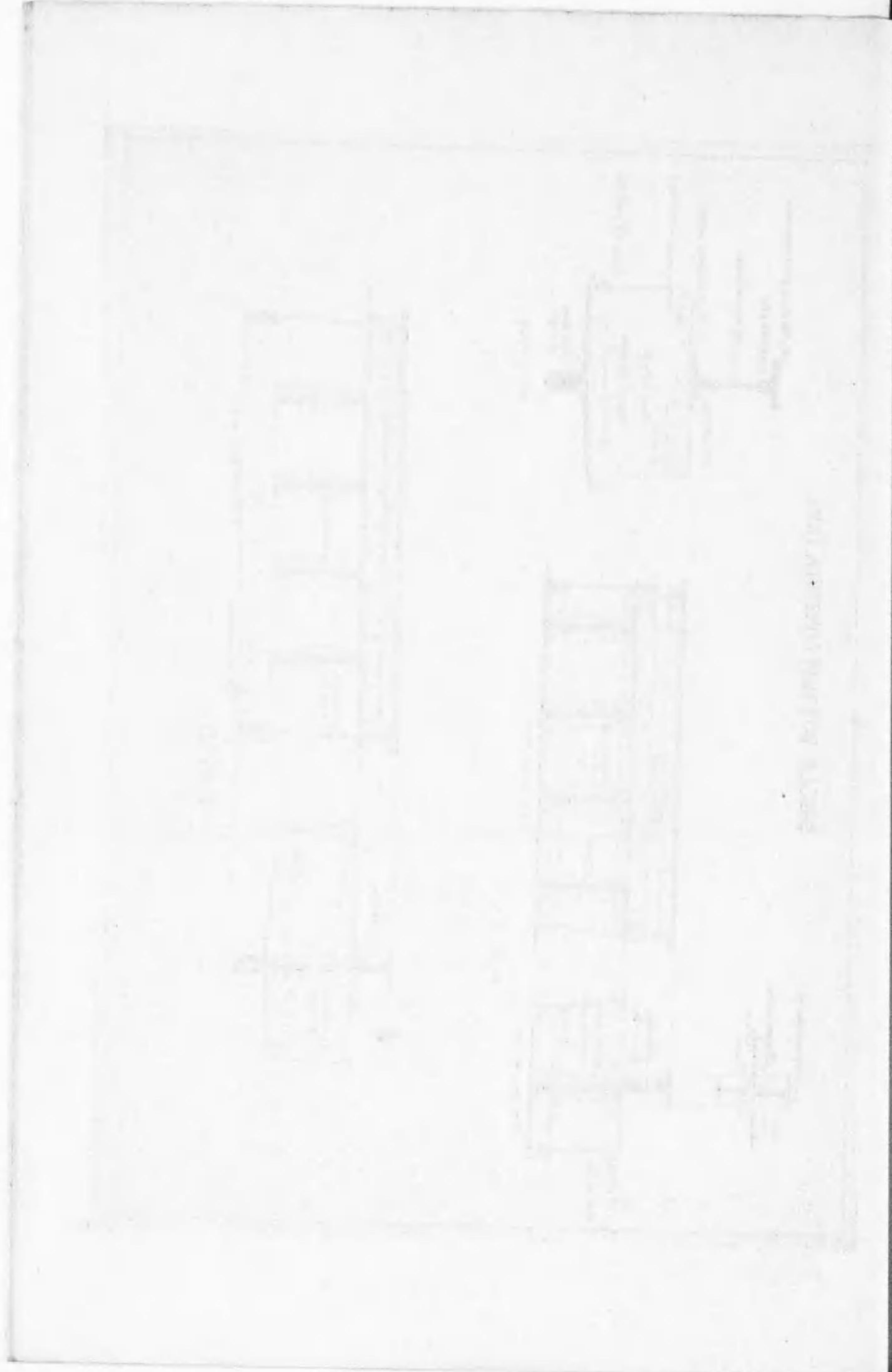
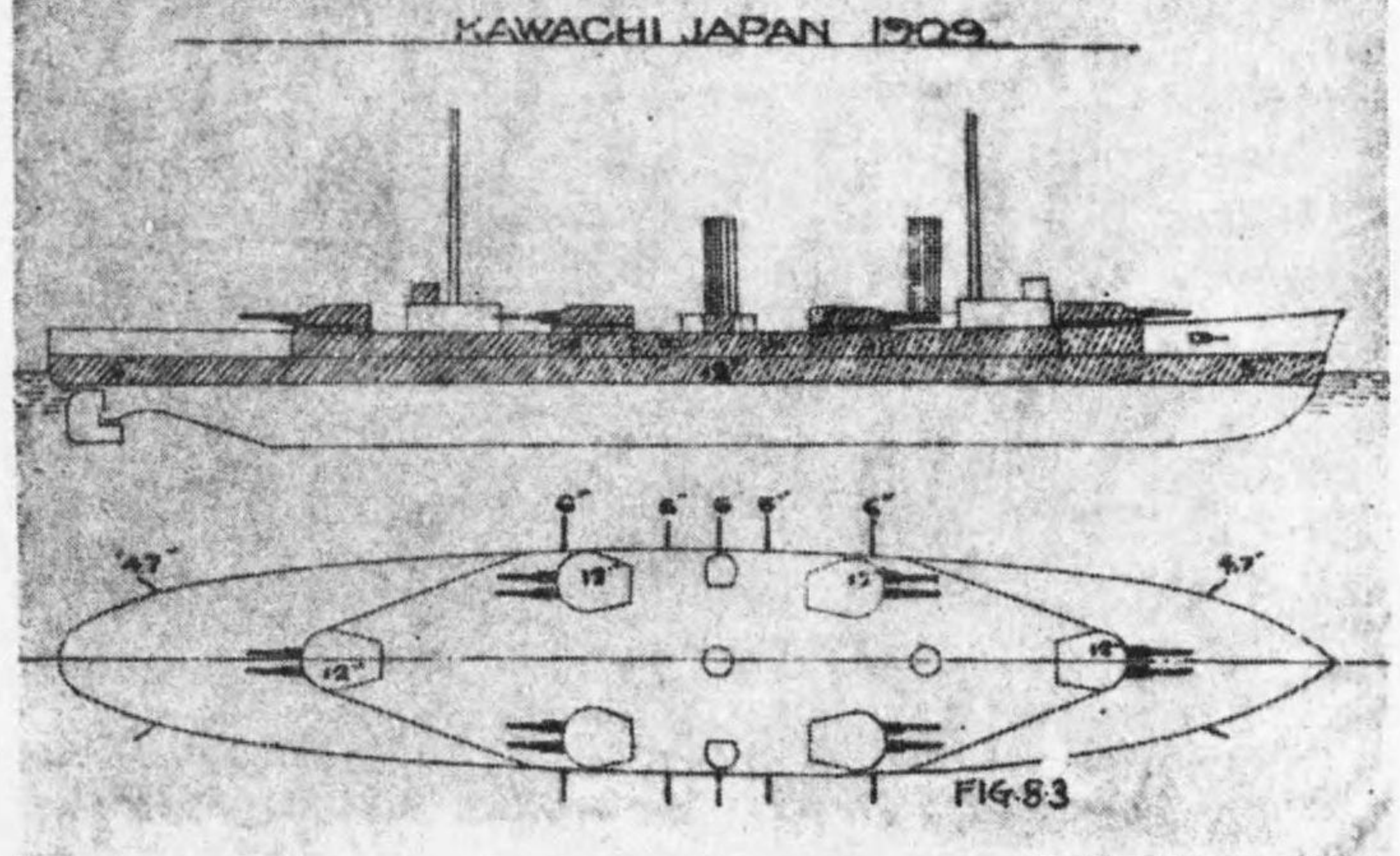
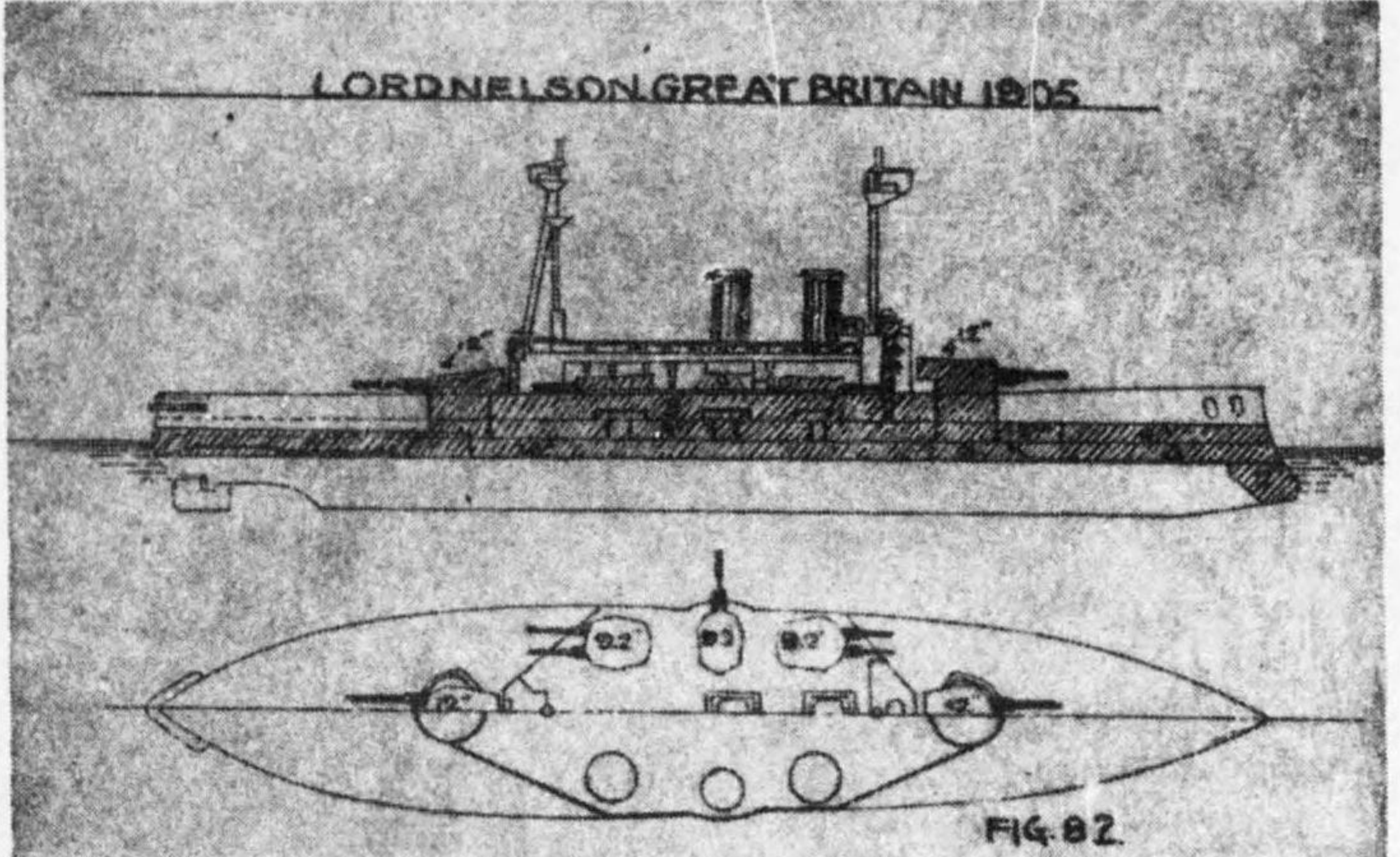
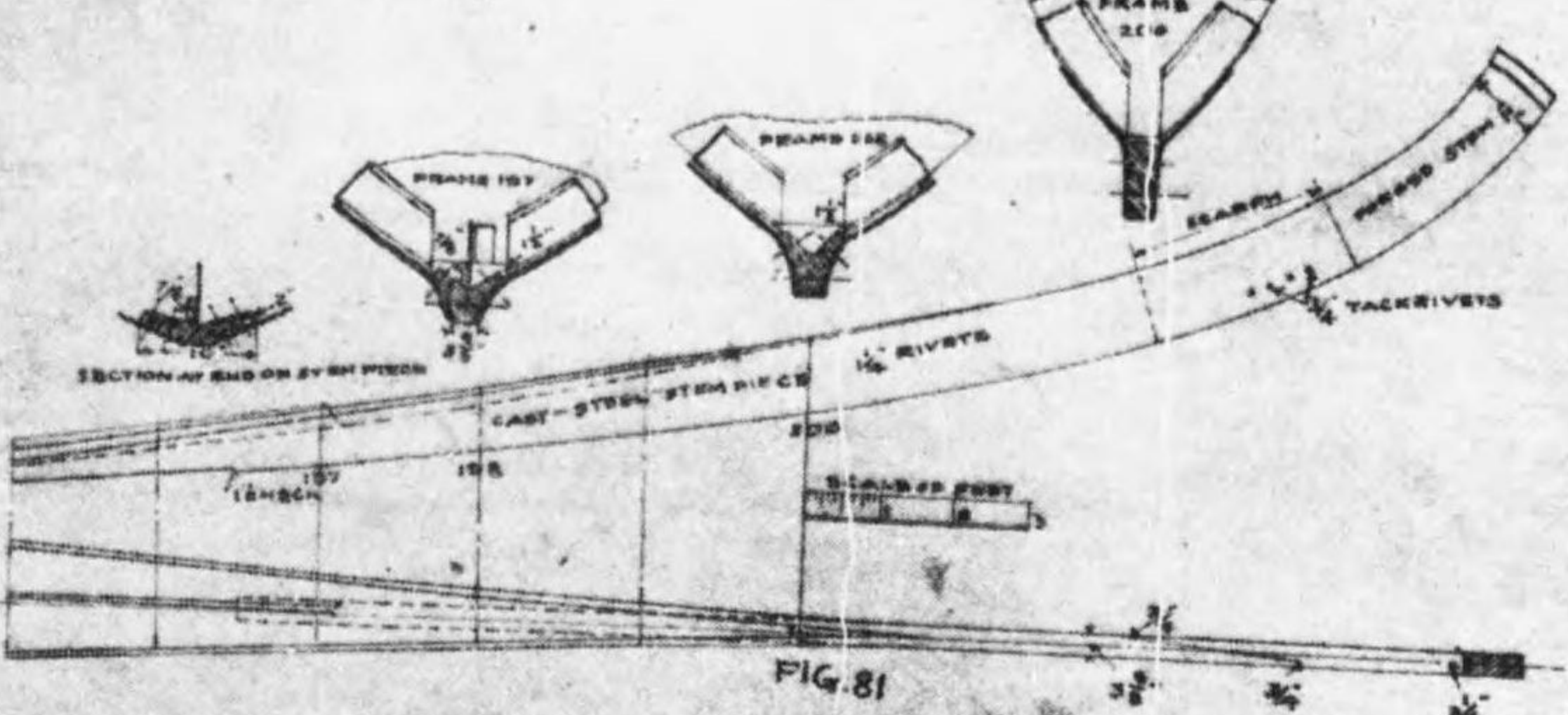
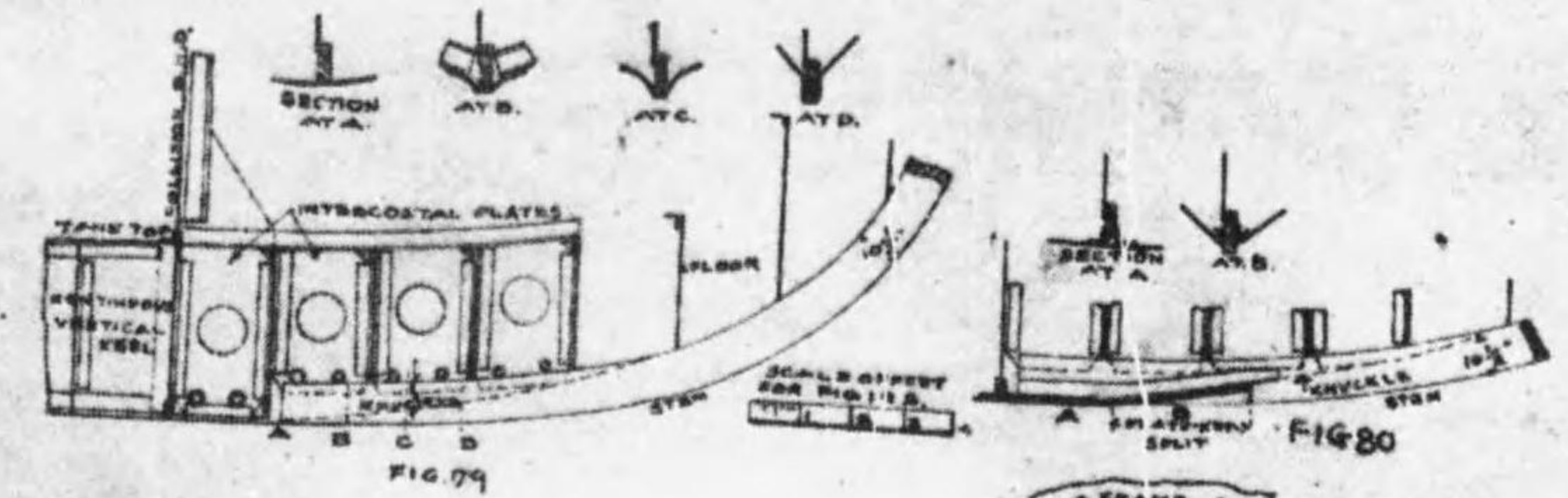

FIG. 75.





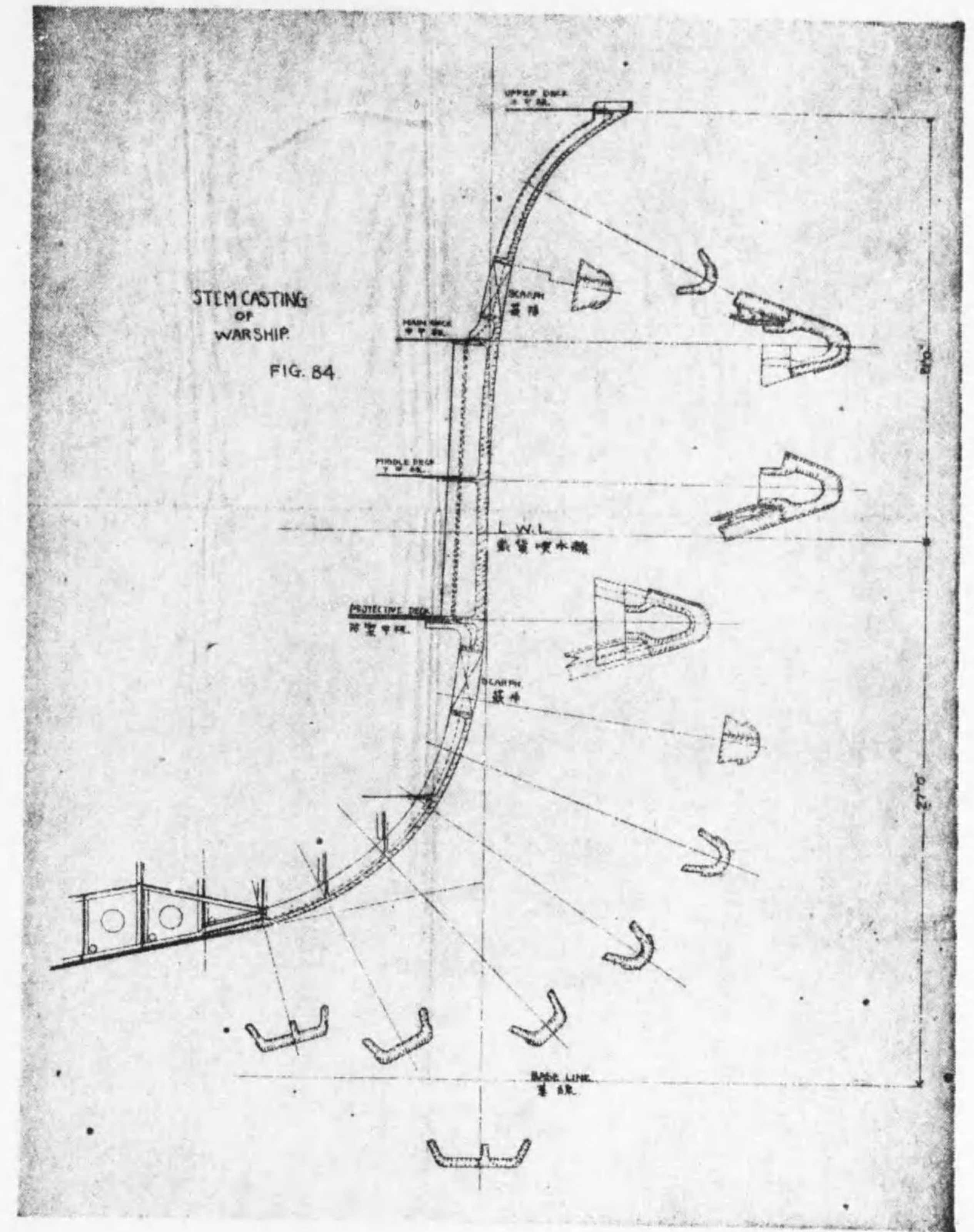
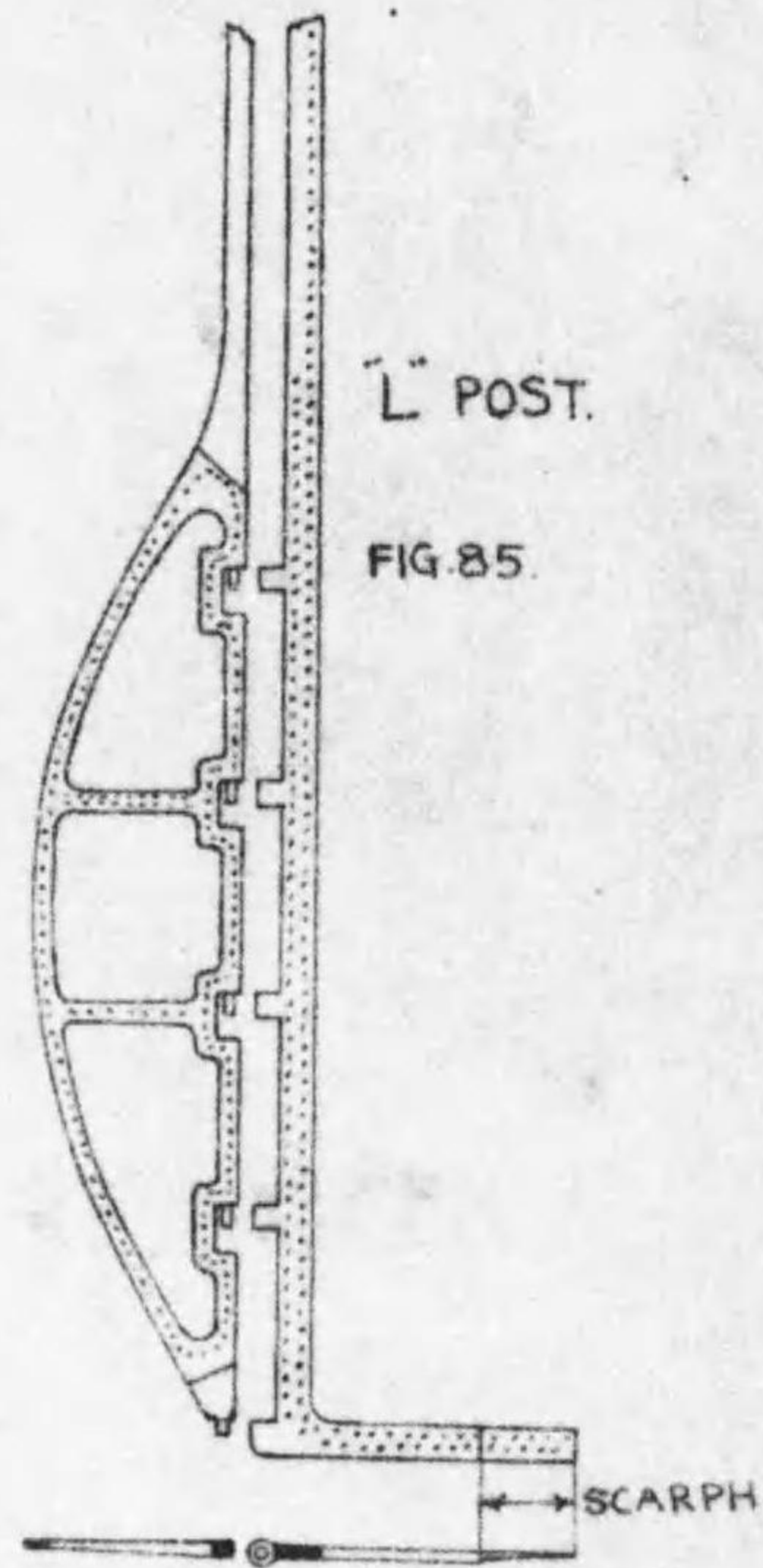
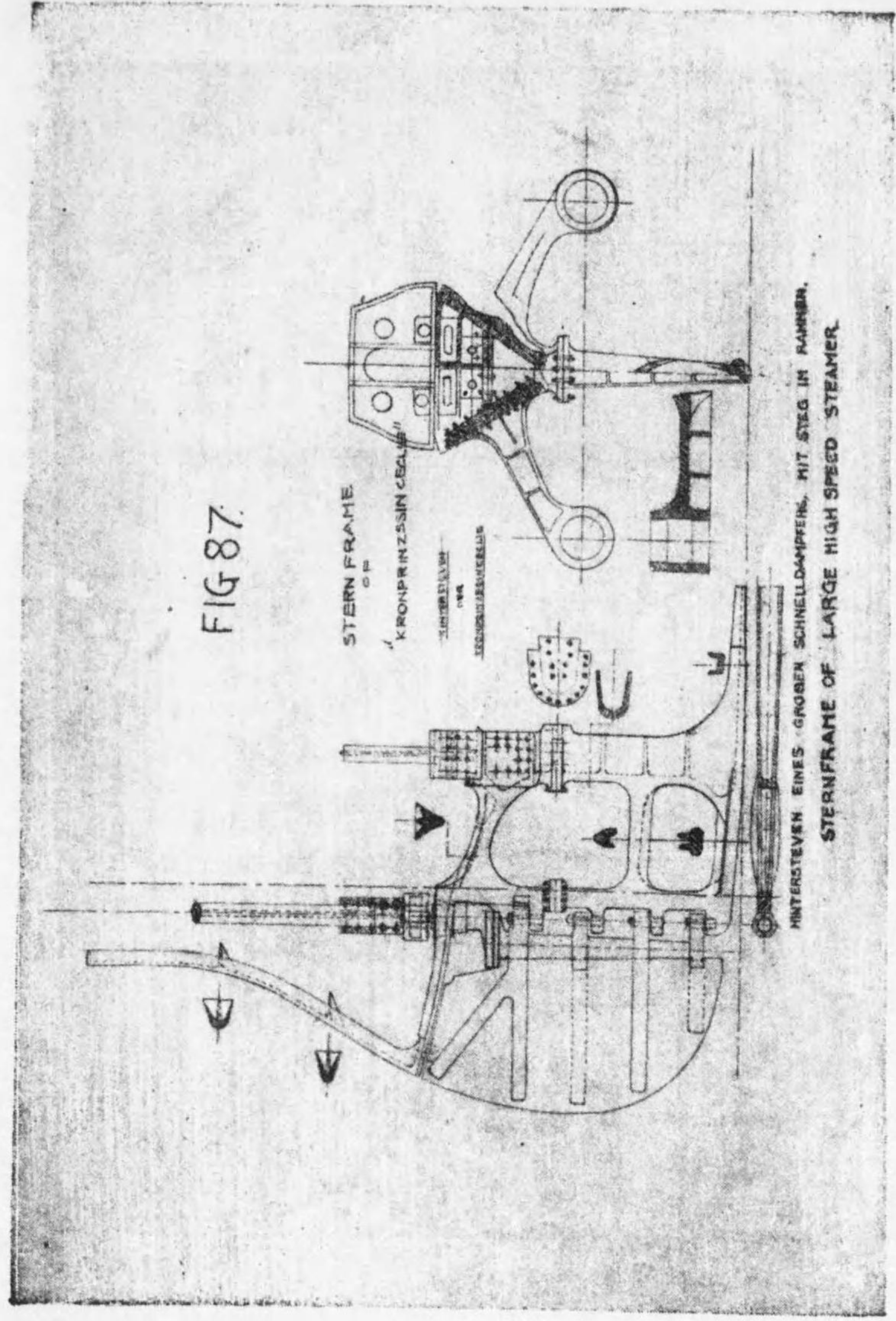
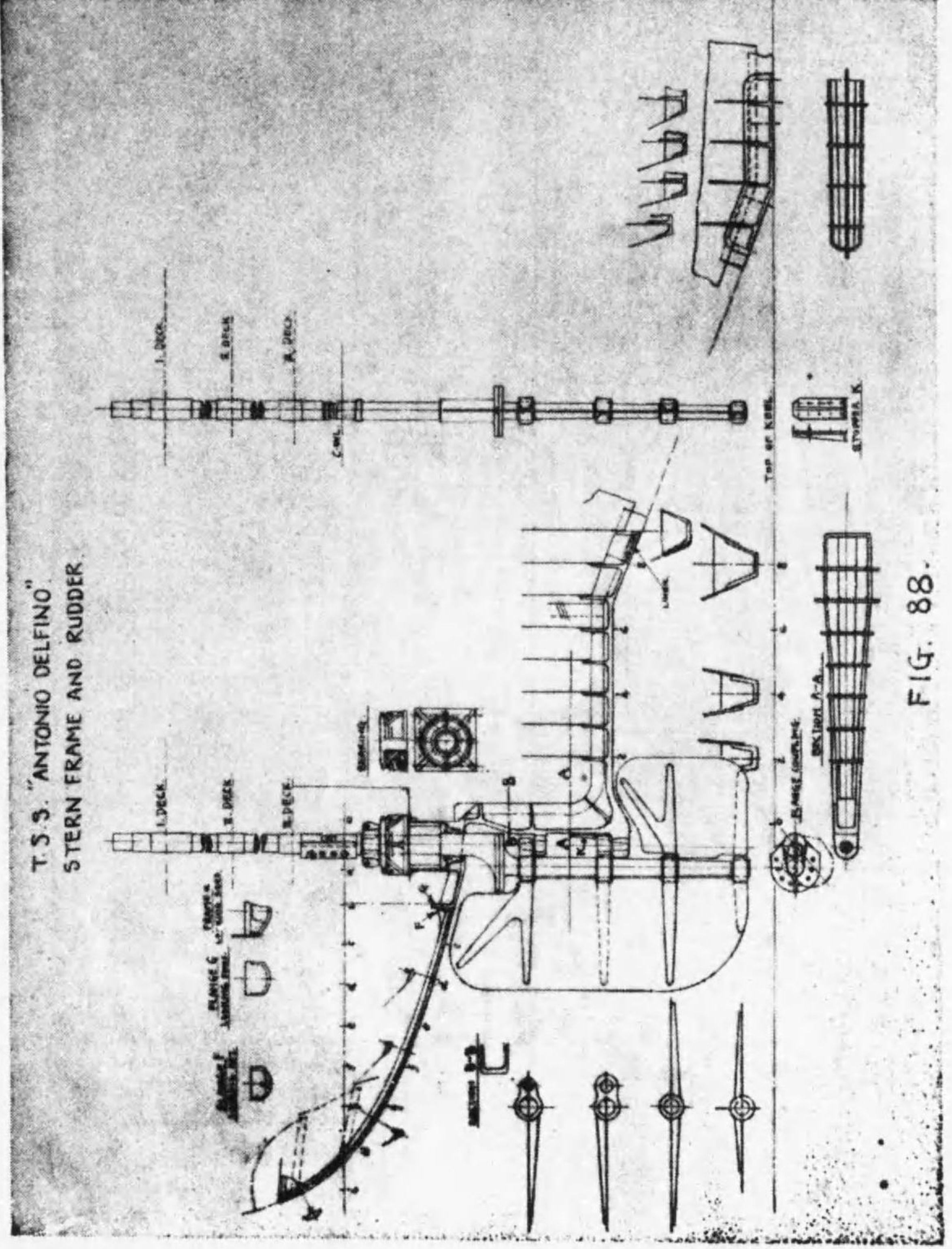

FIG 87.





T.S.S. "ANTONIO DELFINO"
STERN FRAME AND RUDDER.

FIG. 88.

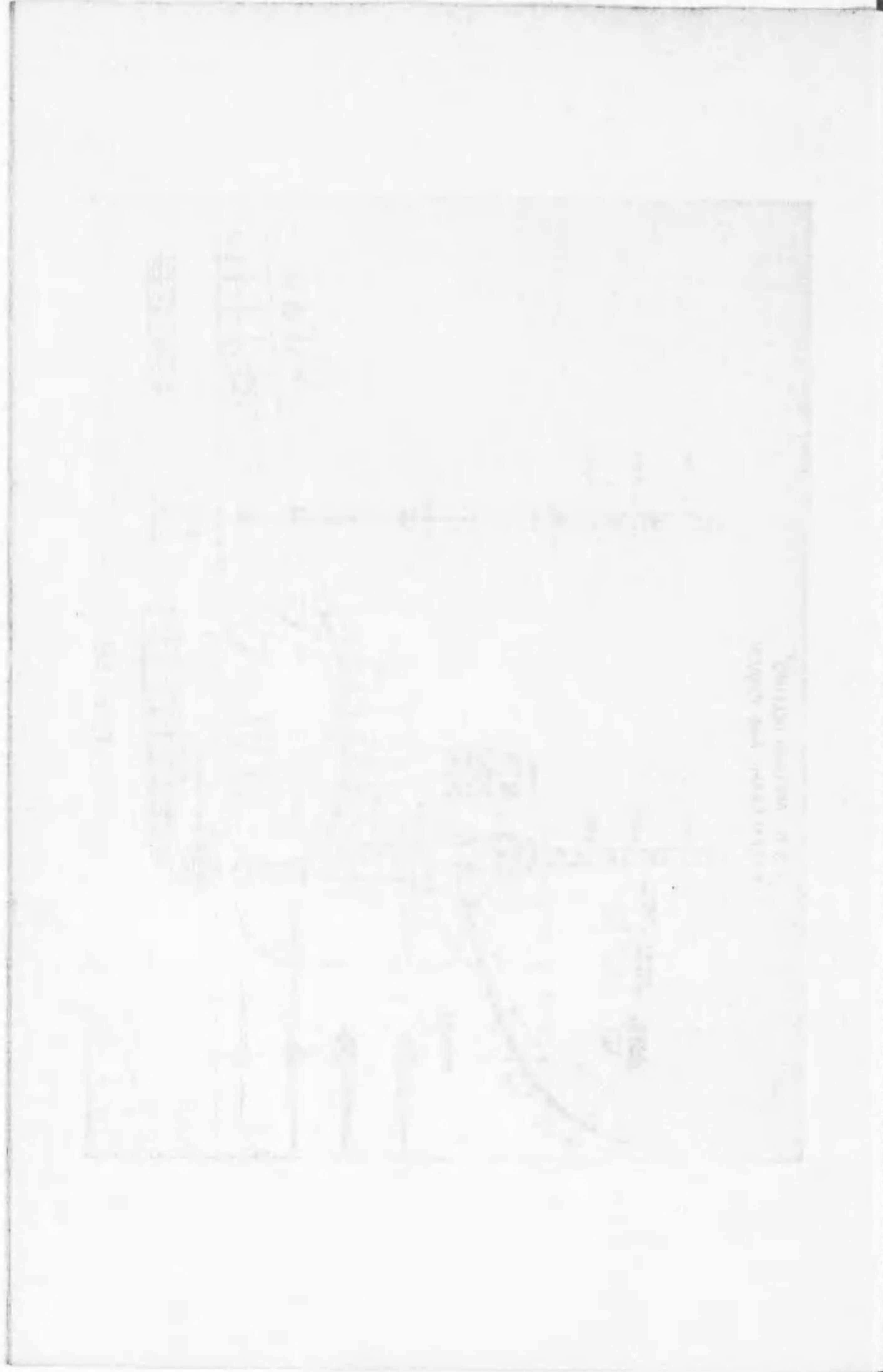

STERN FRAME & RUDDER
OF
TRIPLE SCREW STEAMER.

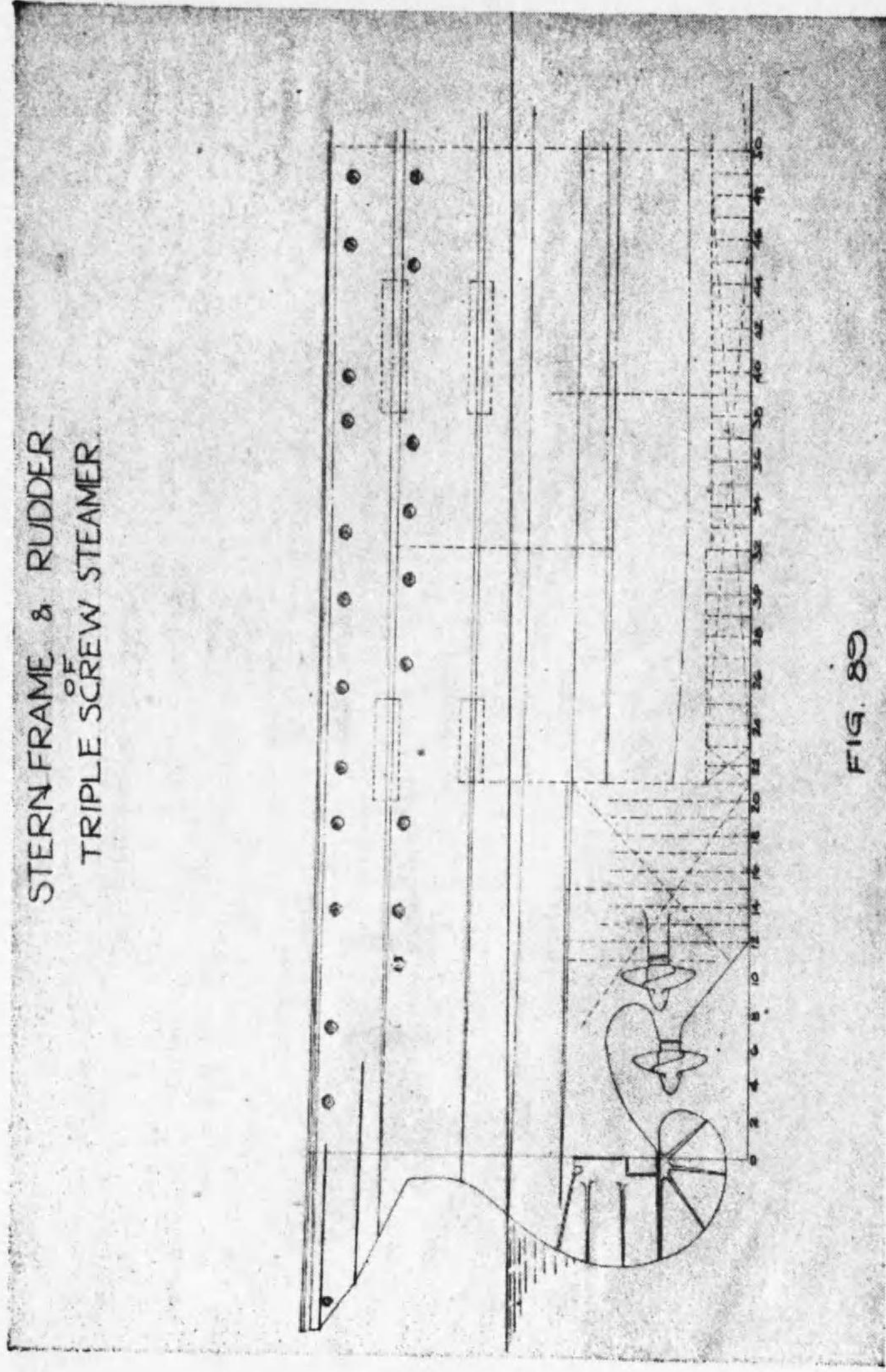

FIG. 80

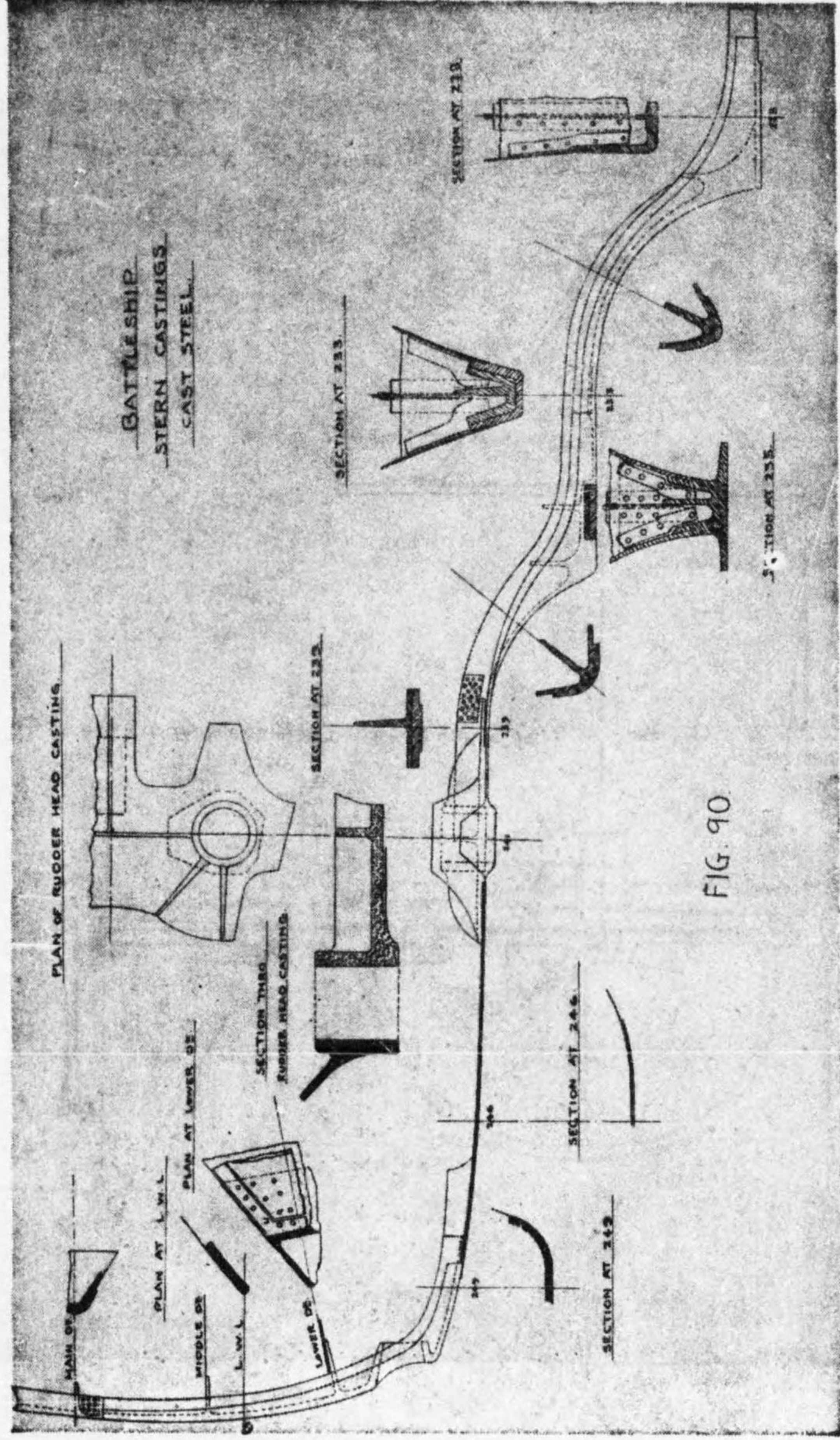
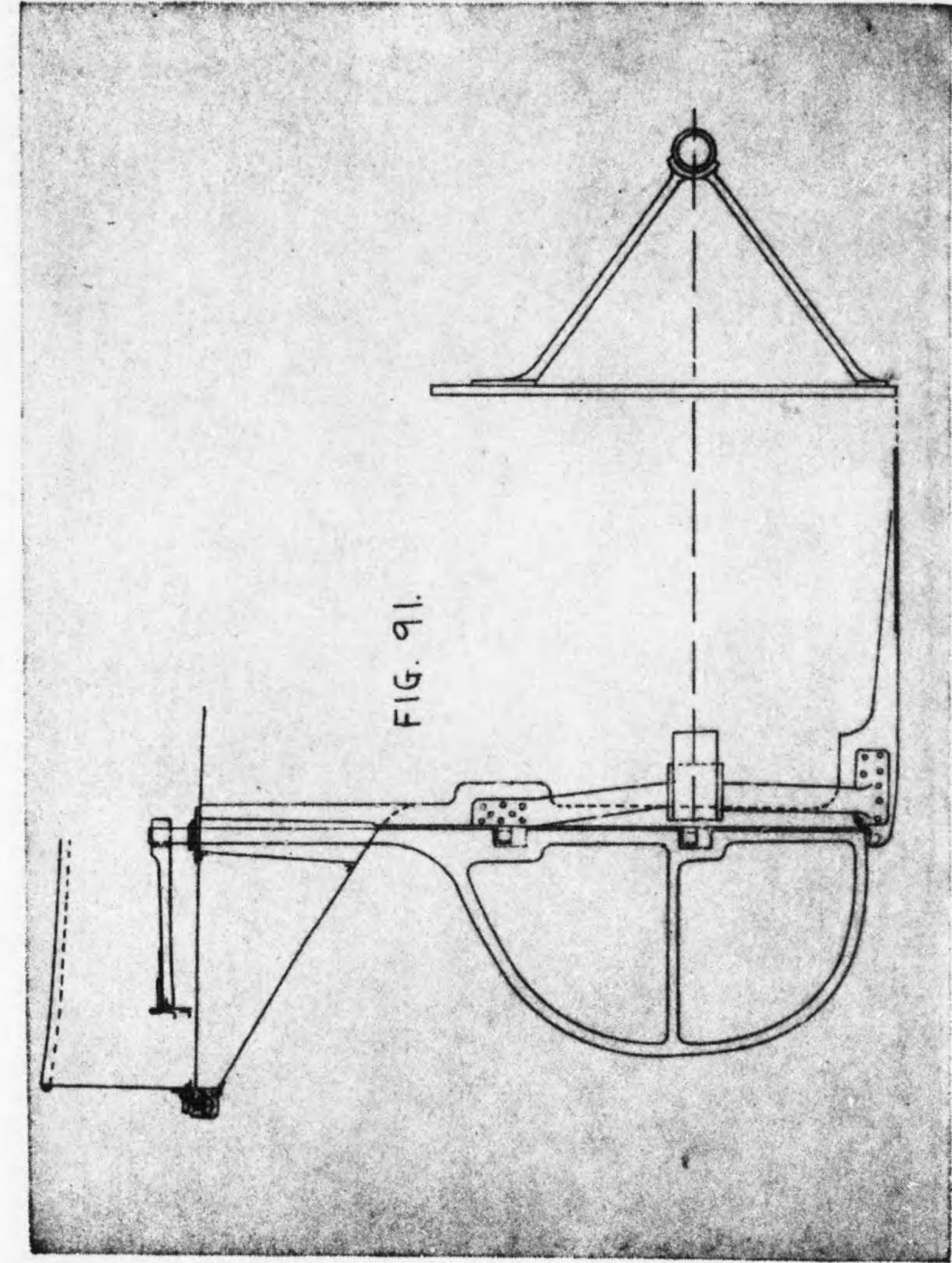
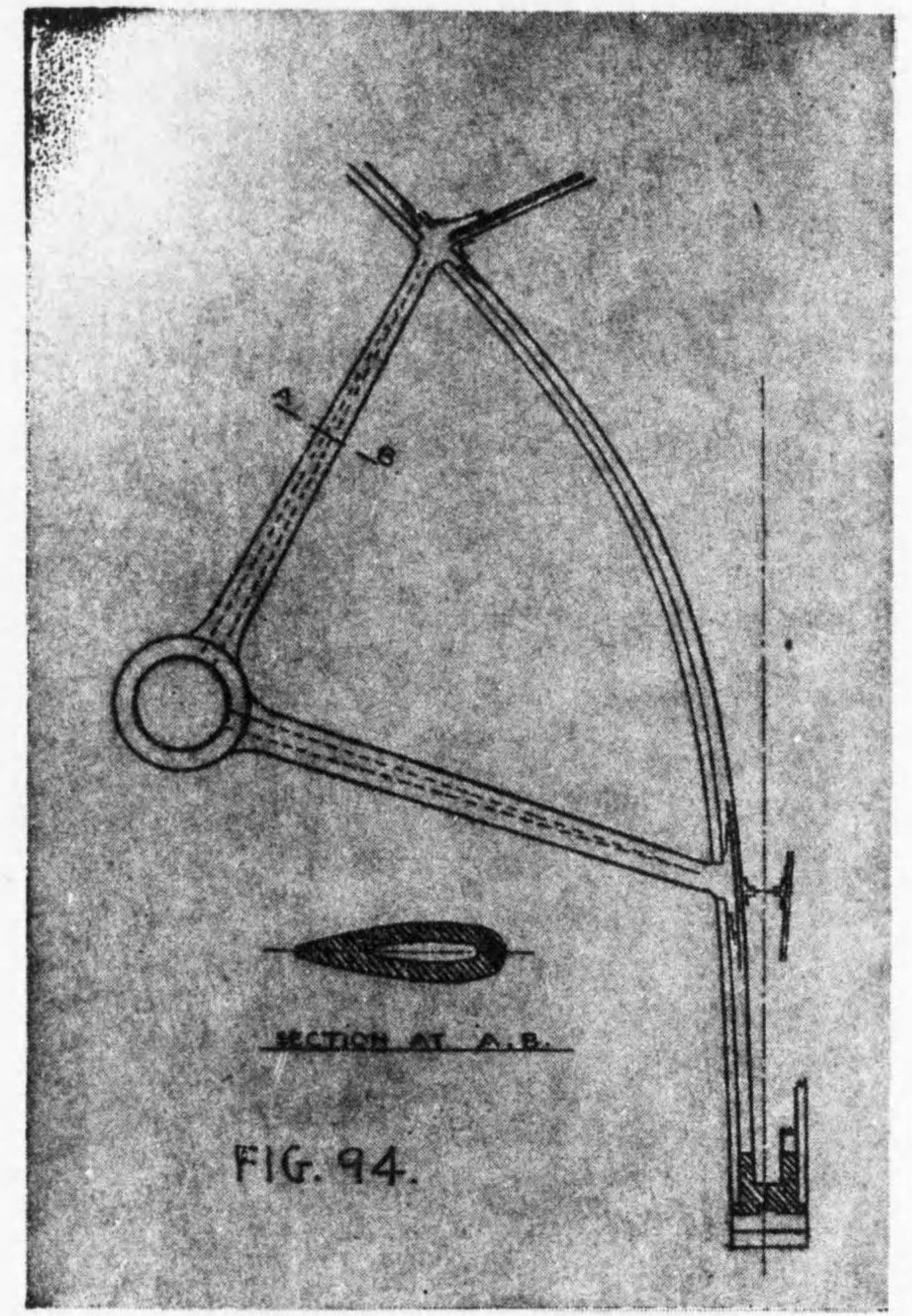
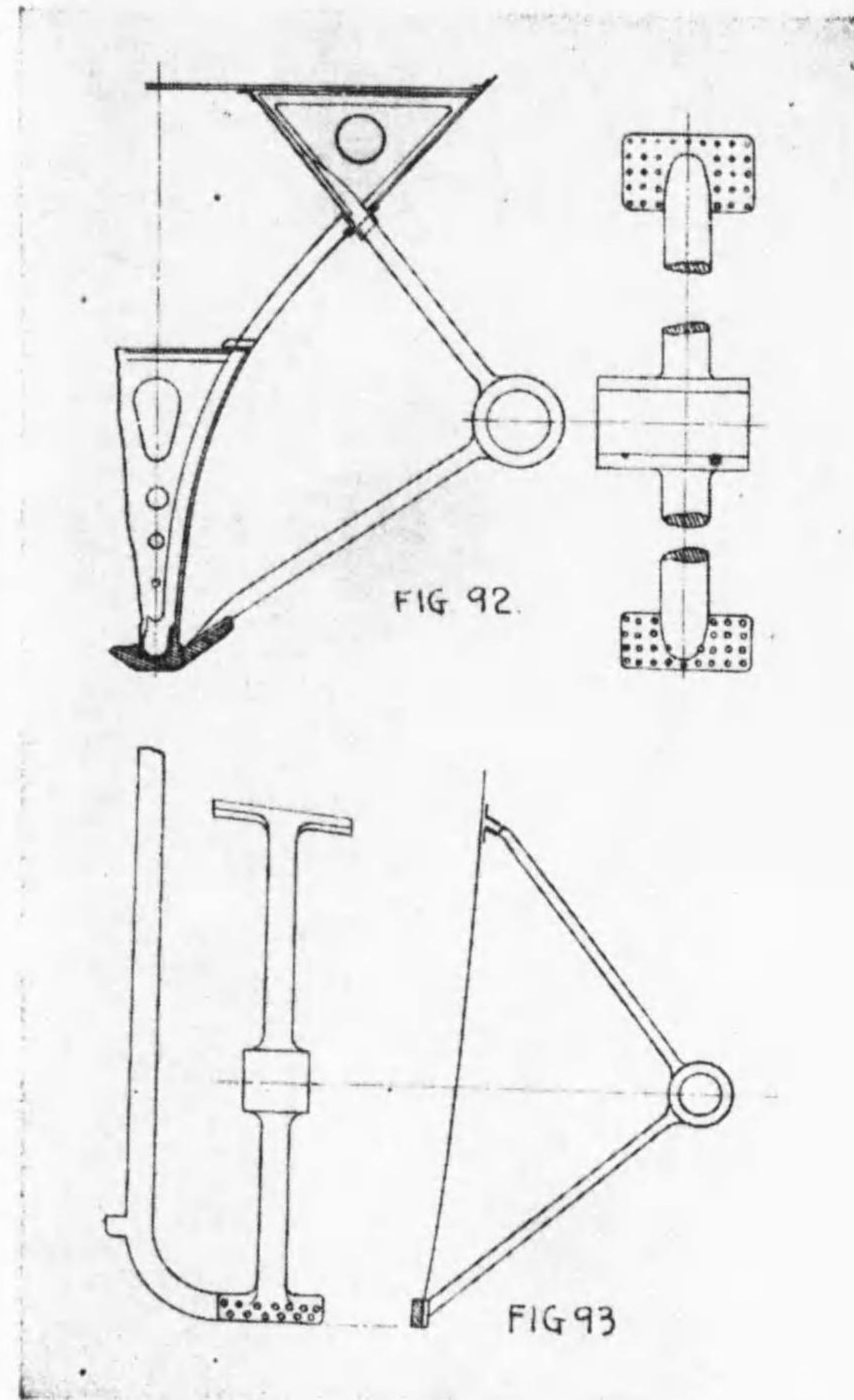
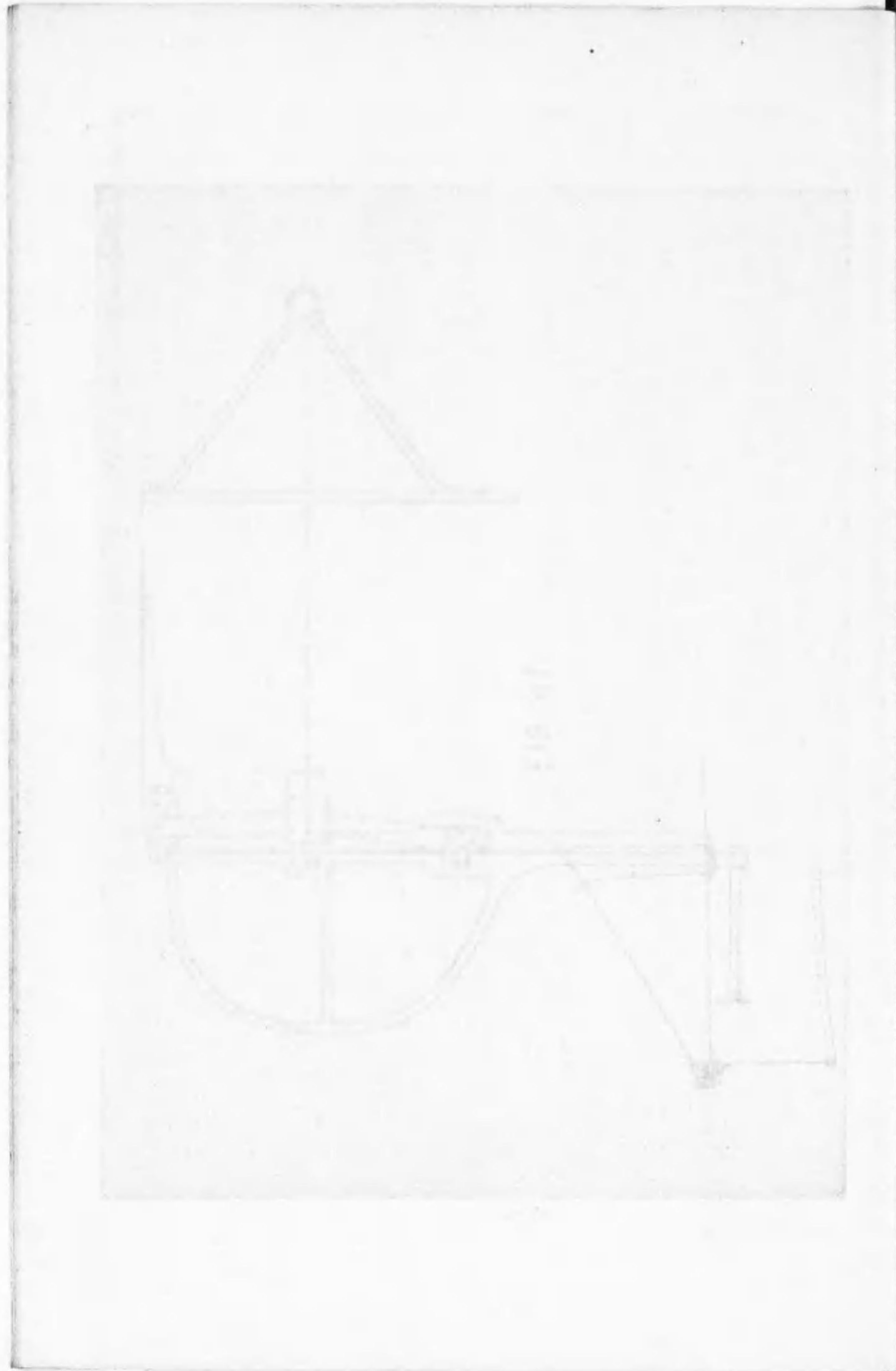
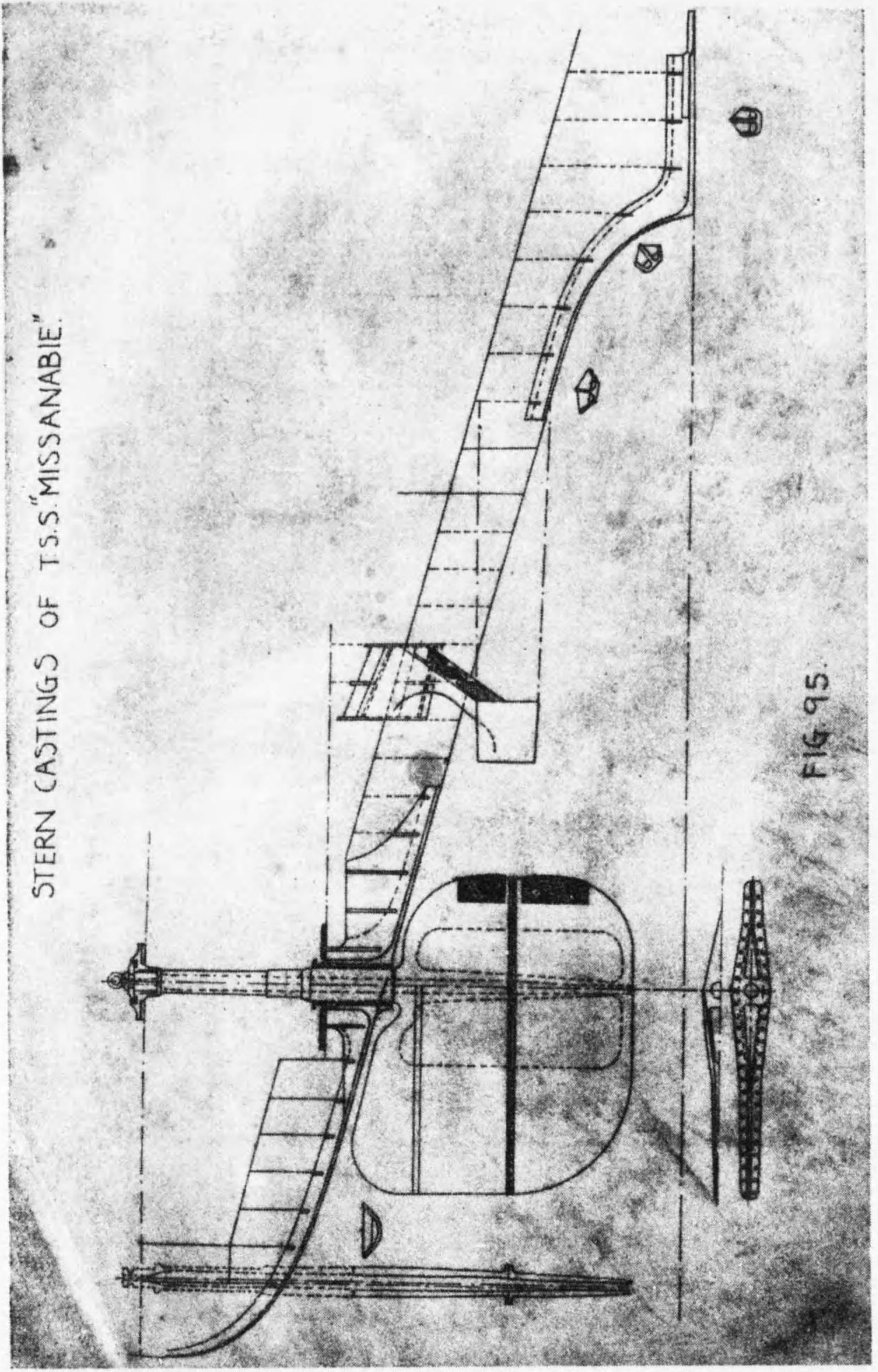

FIG. 90







STERN CASTINGS OF T.S.S. "MISSANABIE."

FIG 95.

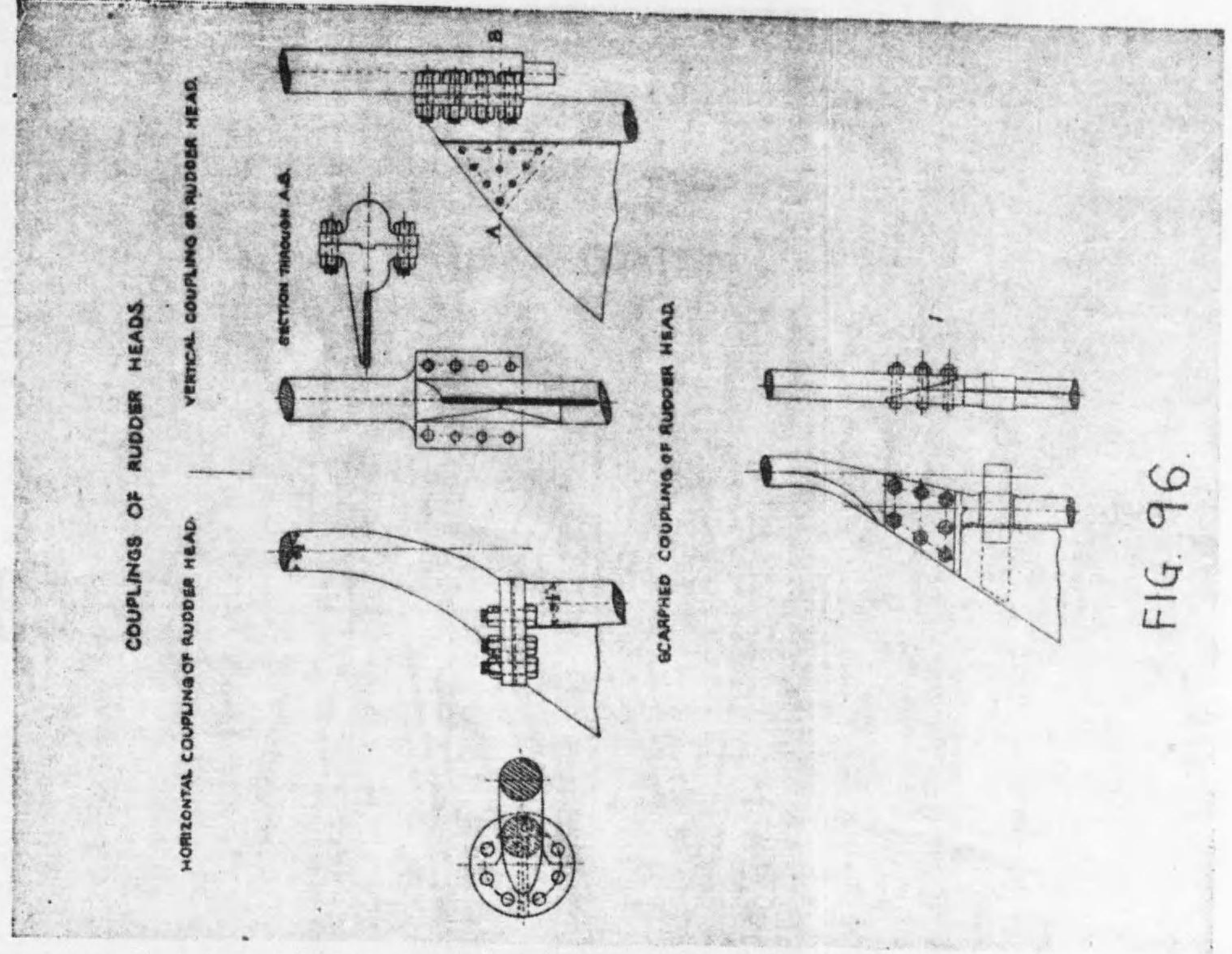
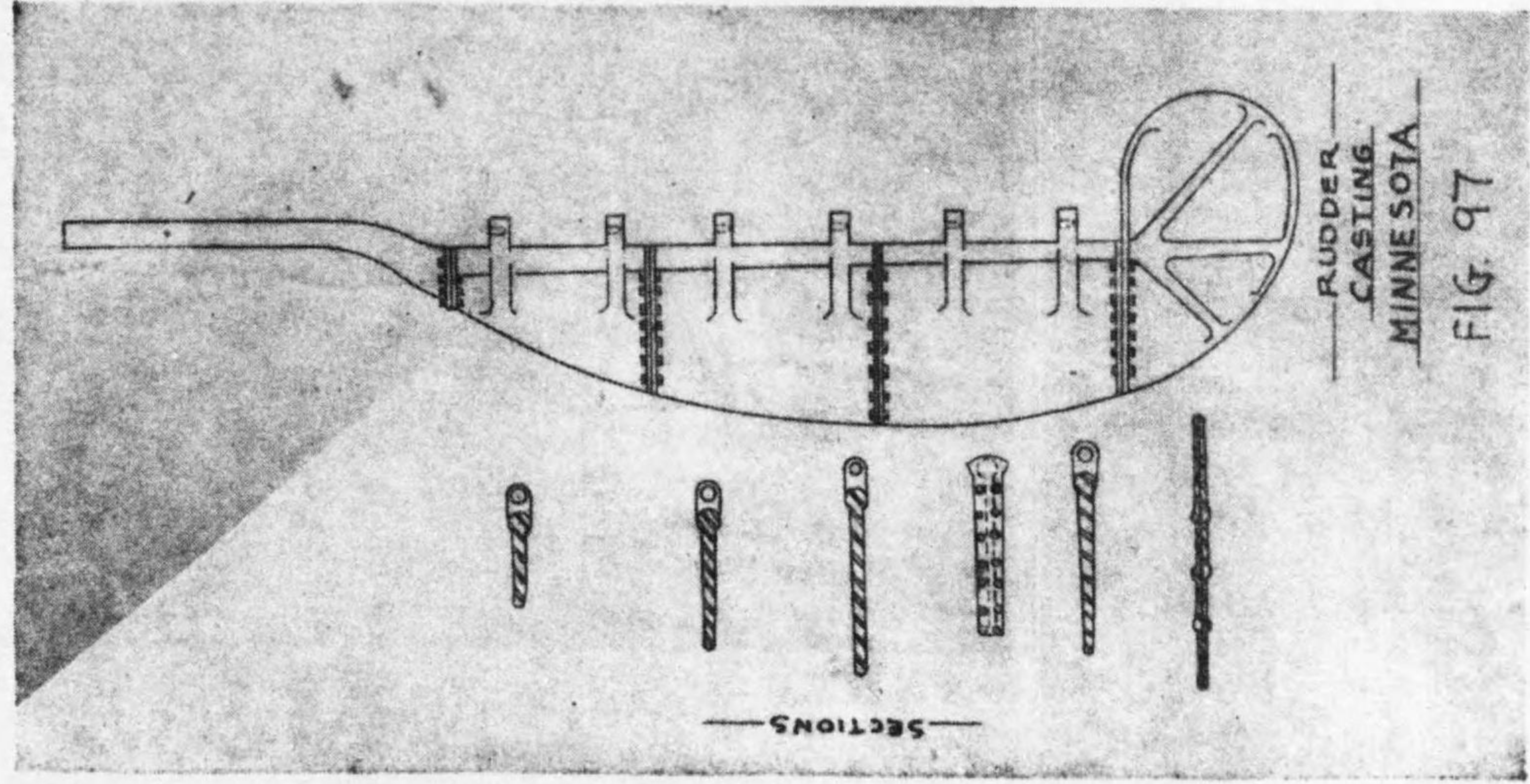
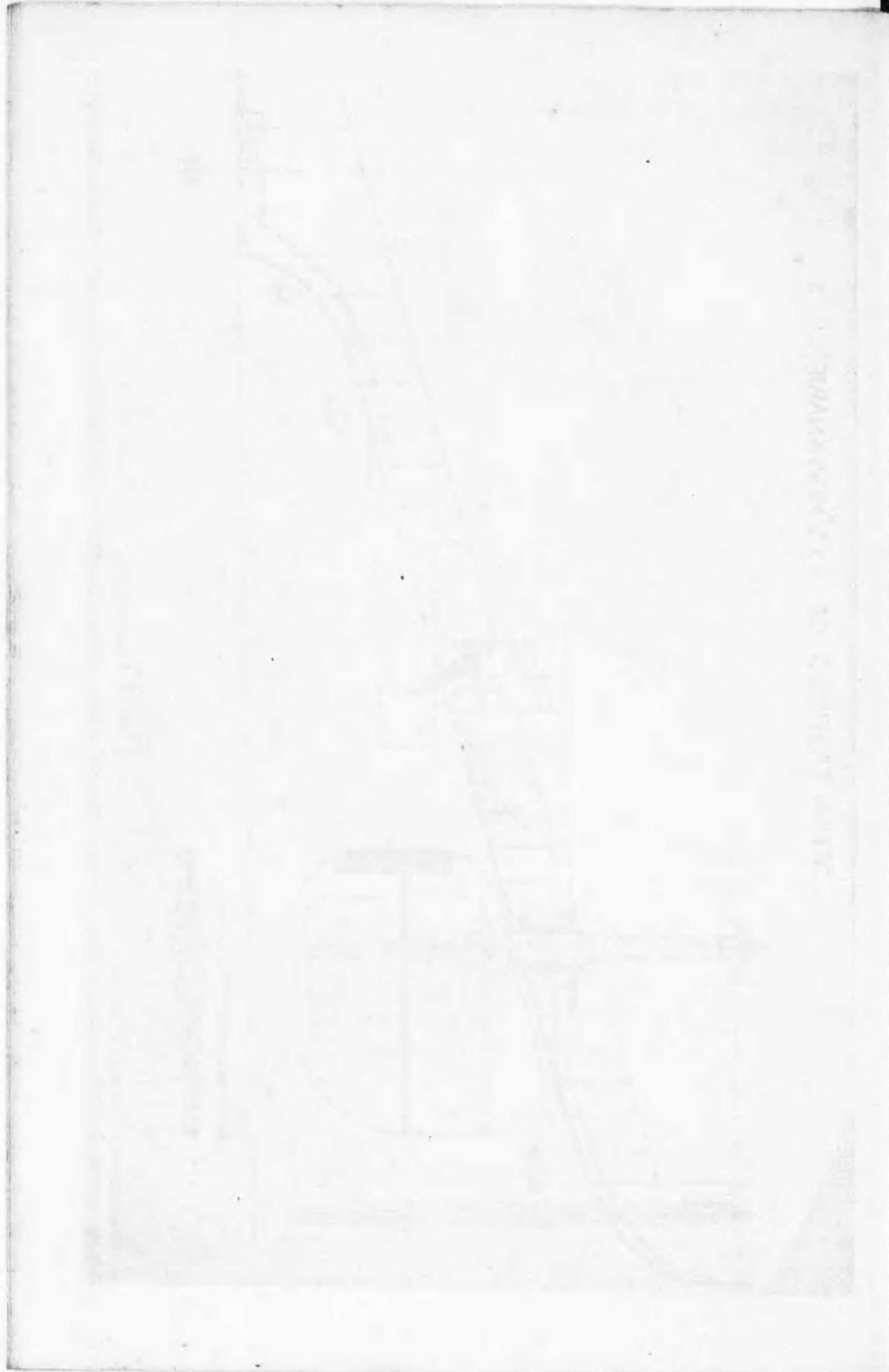

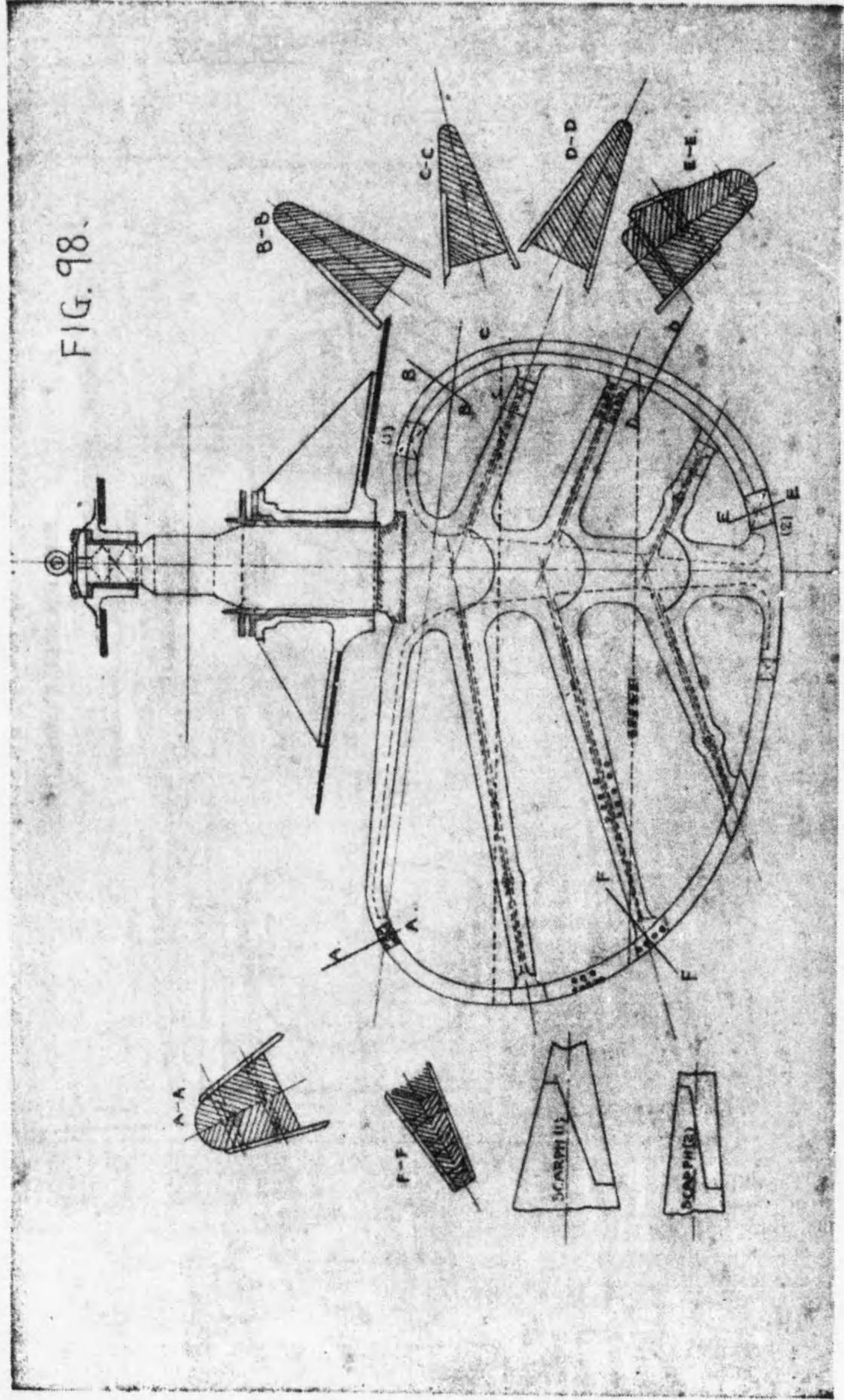
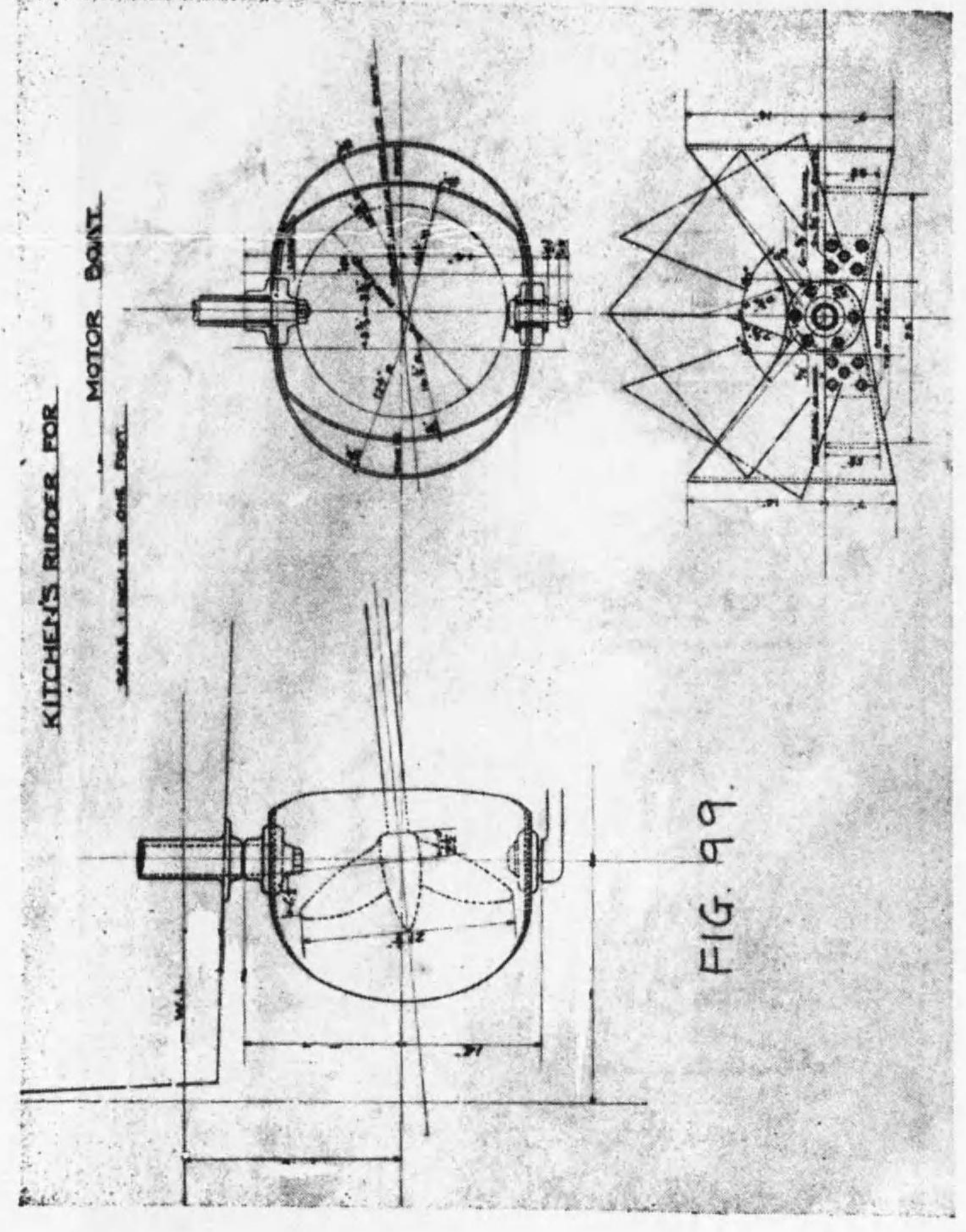



FIG. 100



DOXFORD
BALANCED RUDDER.

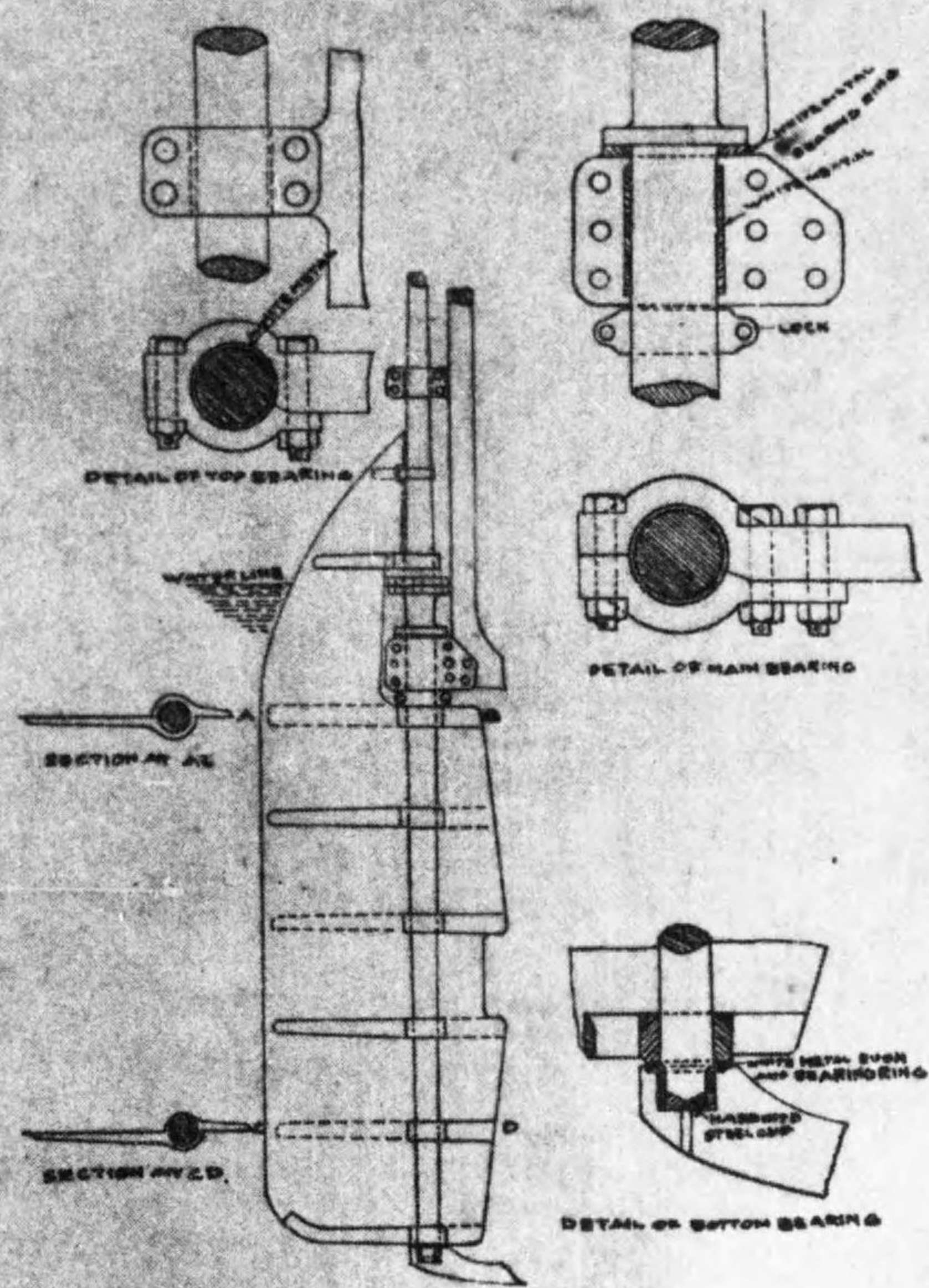

FIG. 100.

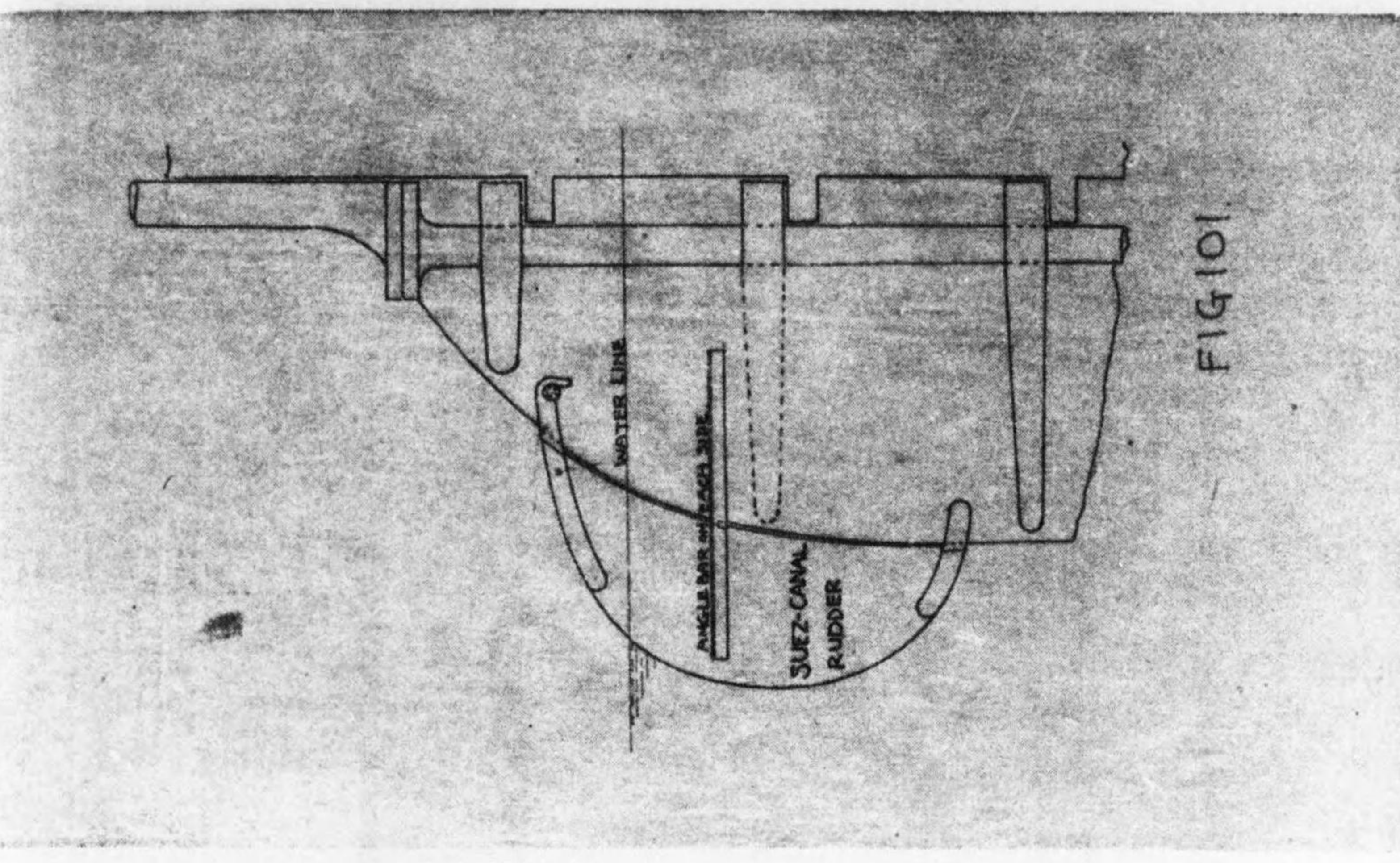

FIG 101

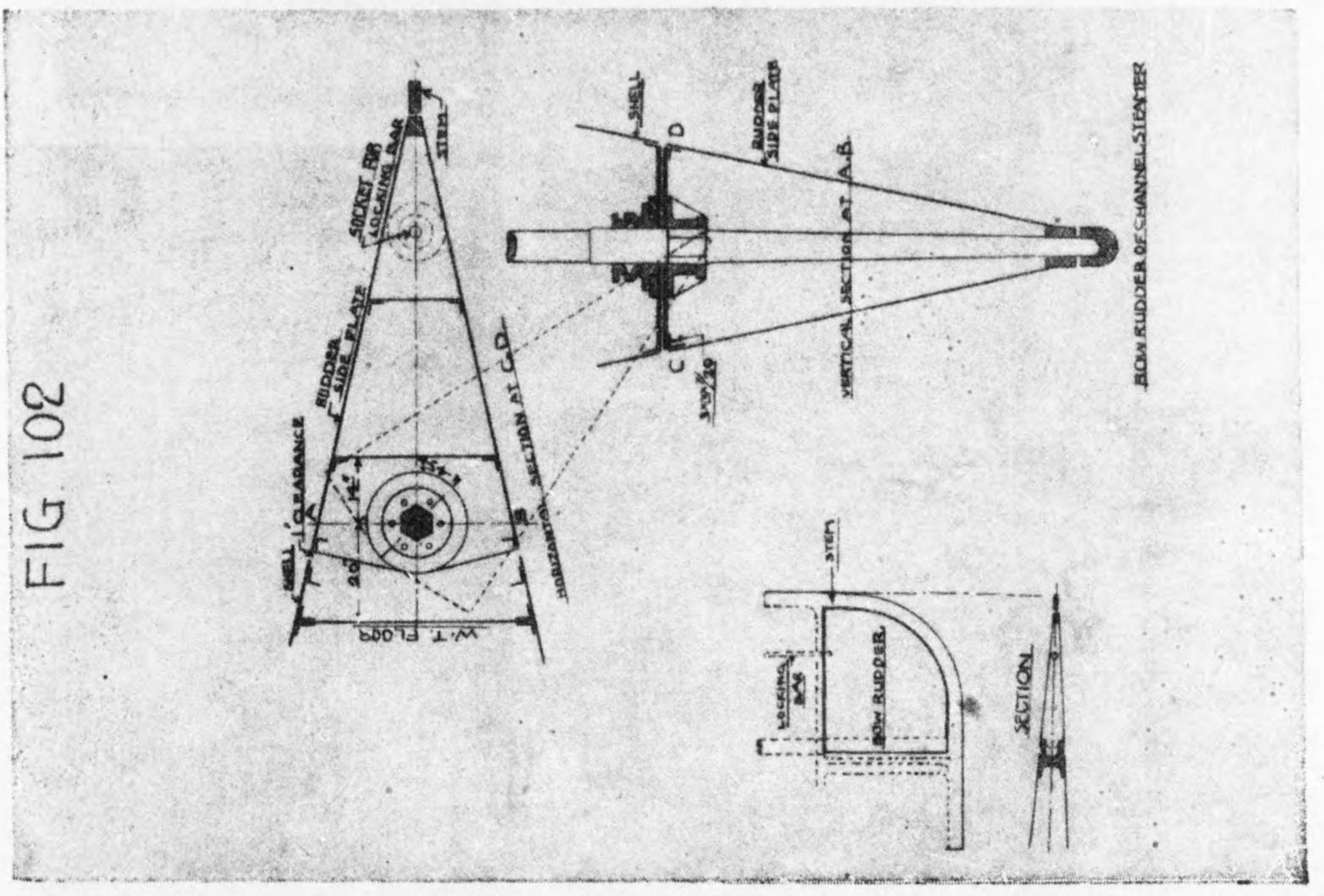
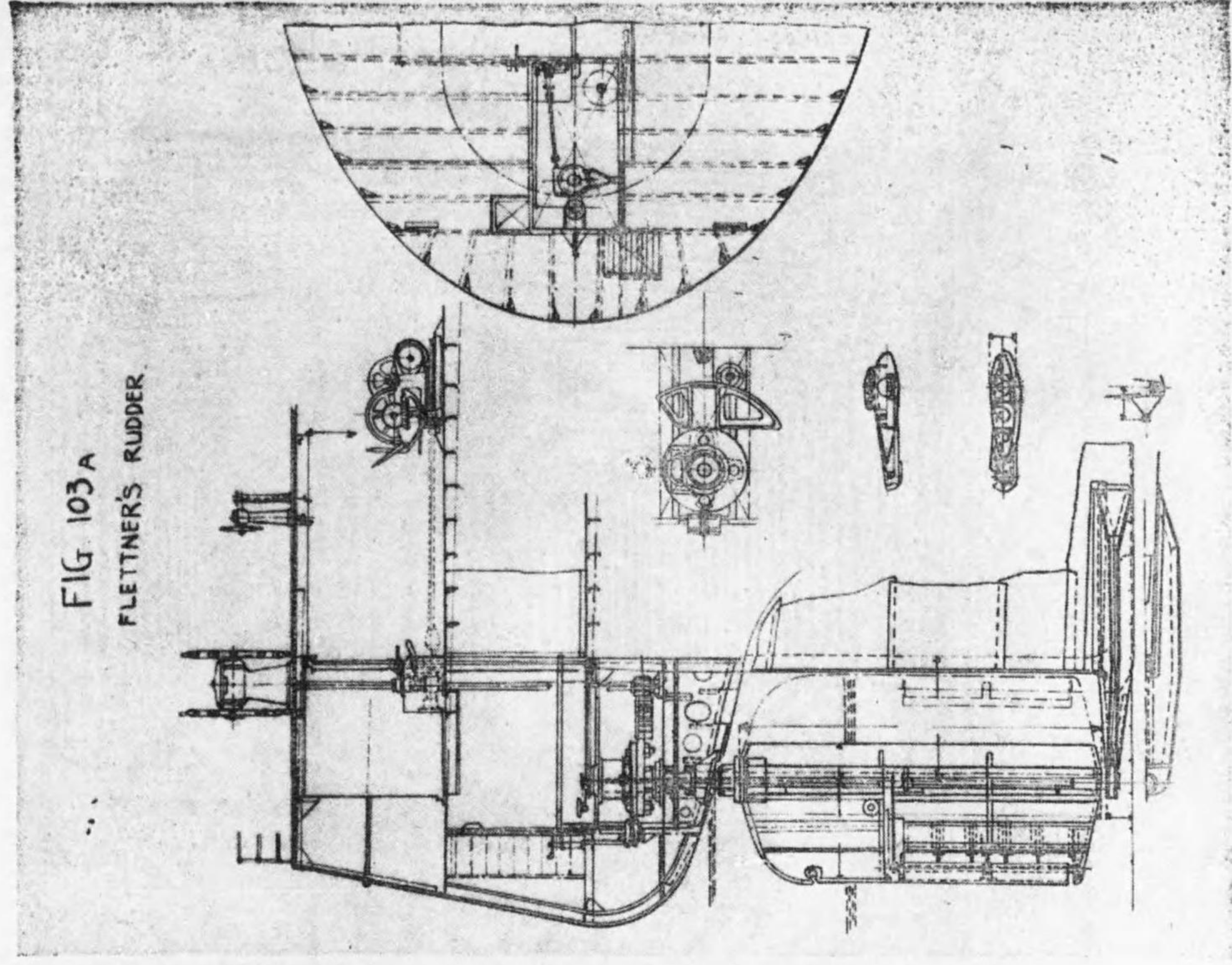
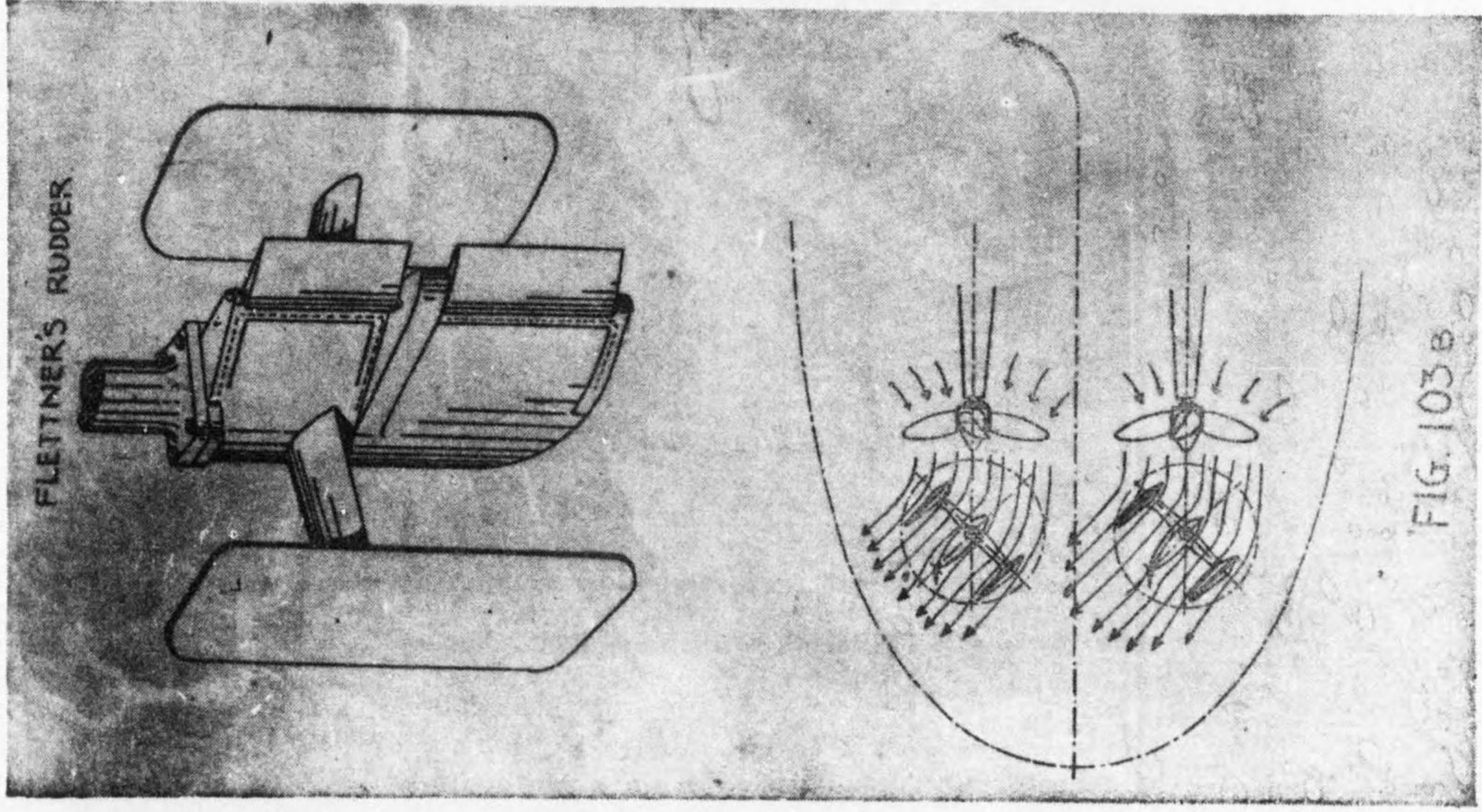

FIG 102

BOW RUDDER OF CHANNEL STEAMER

FIG. 103



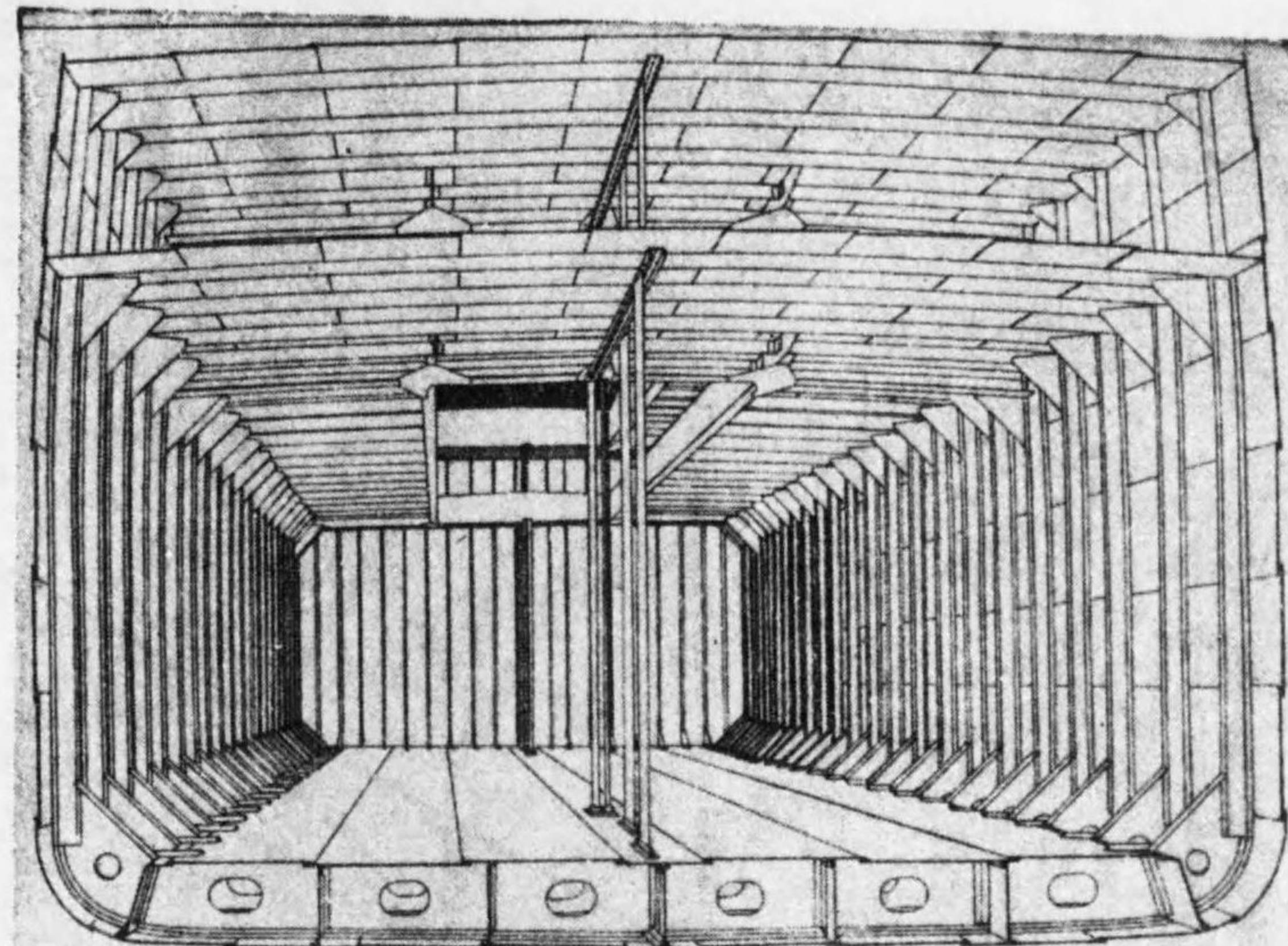

FIG 104. VESSEL WITHOUT SIDE STRINGERS.

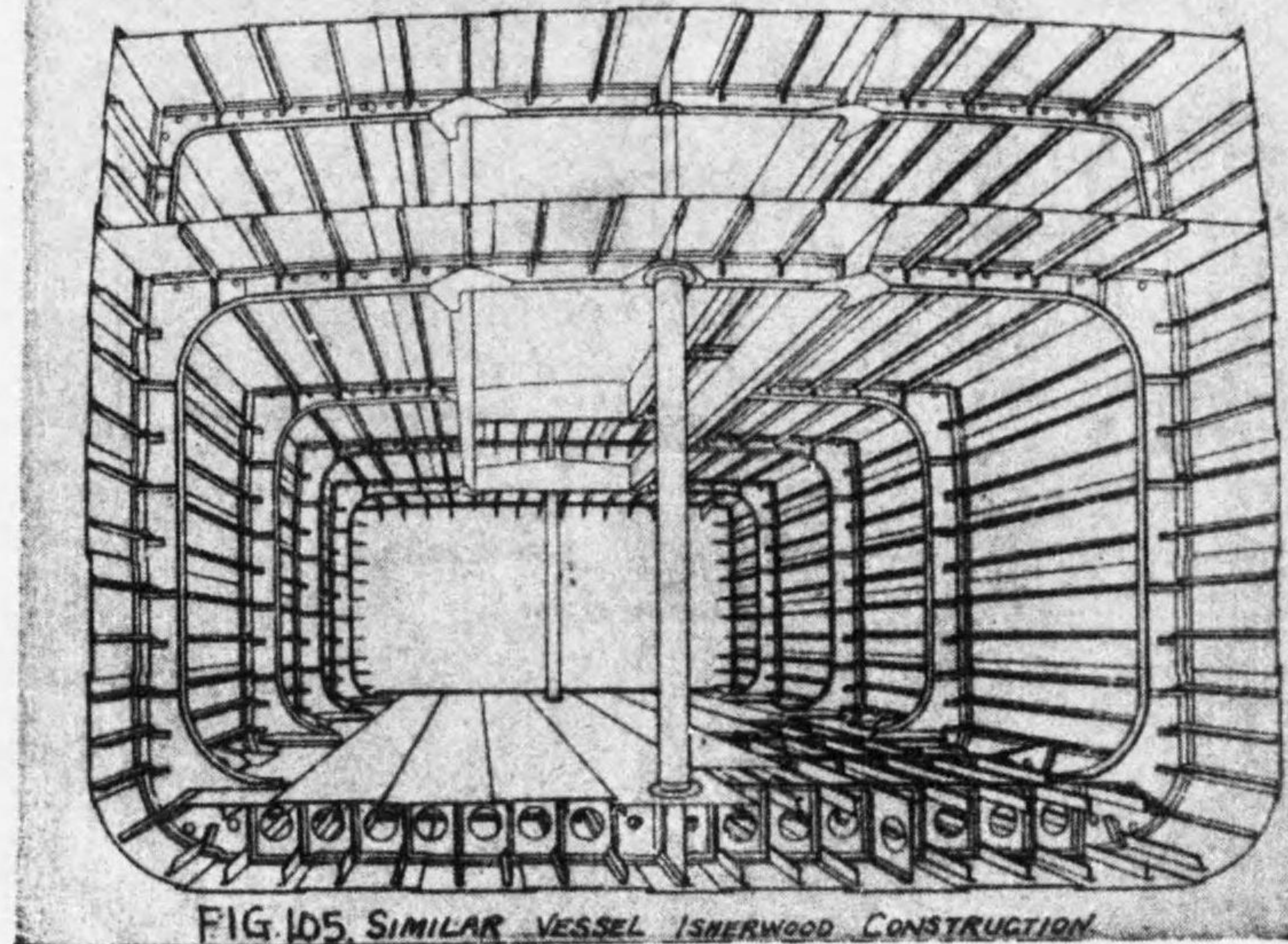

FIG 105. SIMILAR VESSEL ISHERWOOD CONSTRUCTION.

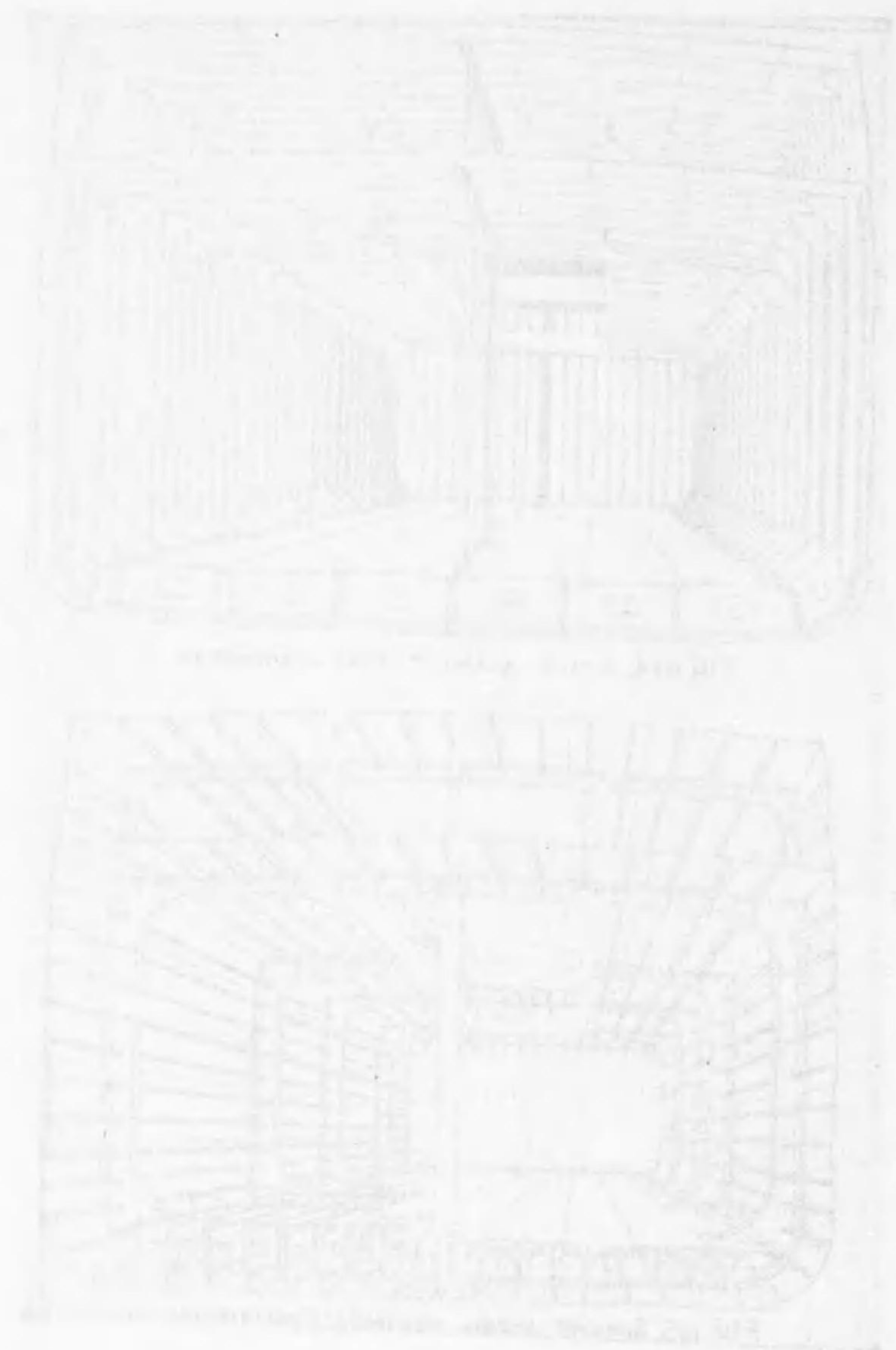

FIG. 106.

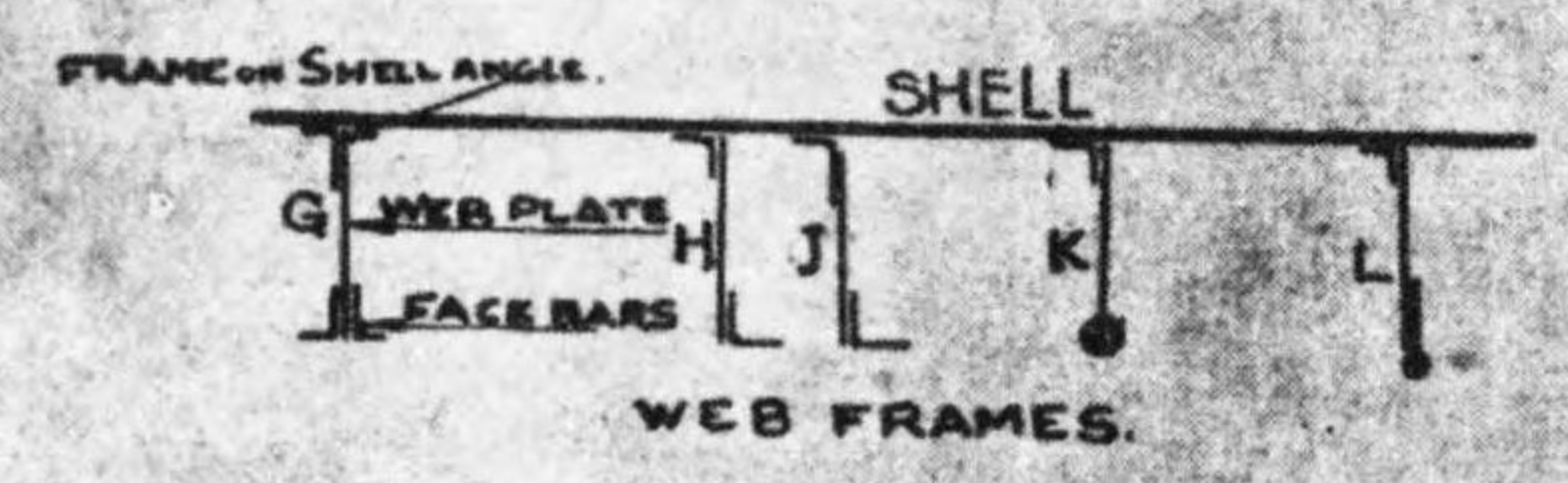
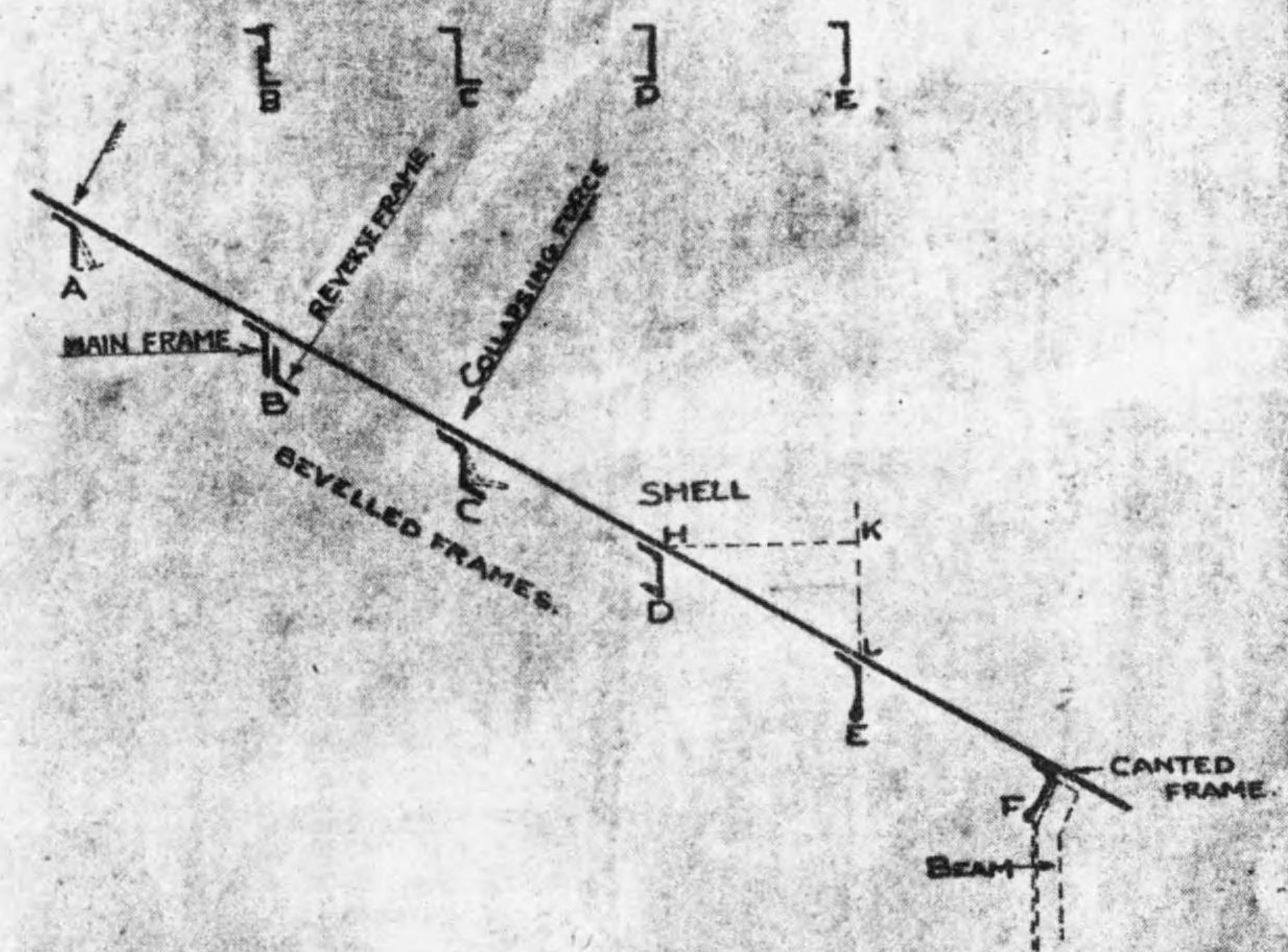



FIG 107

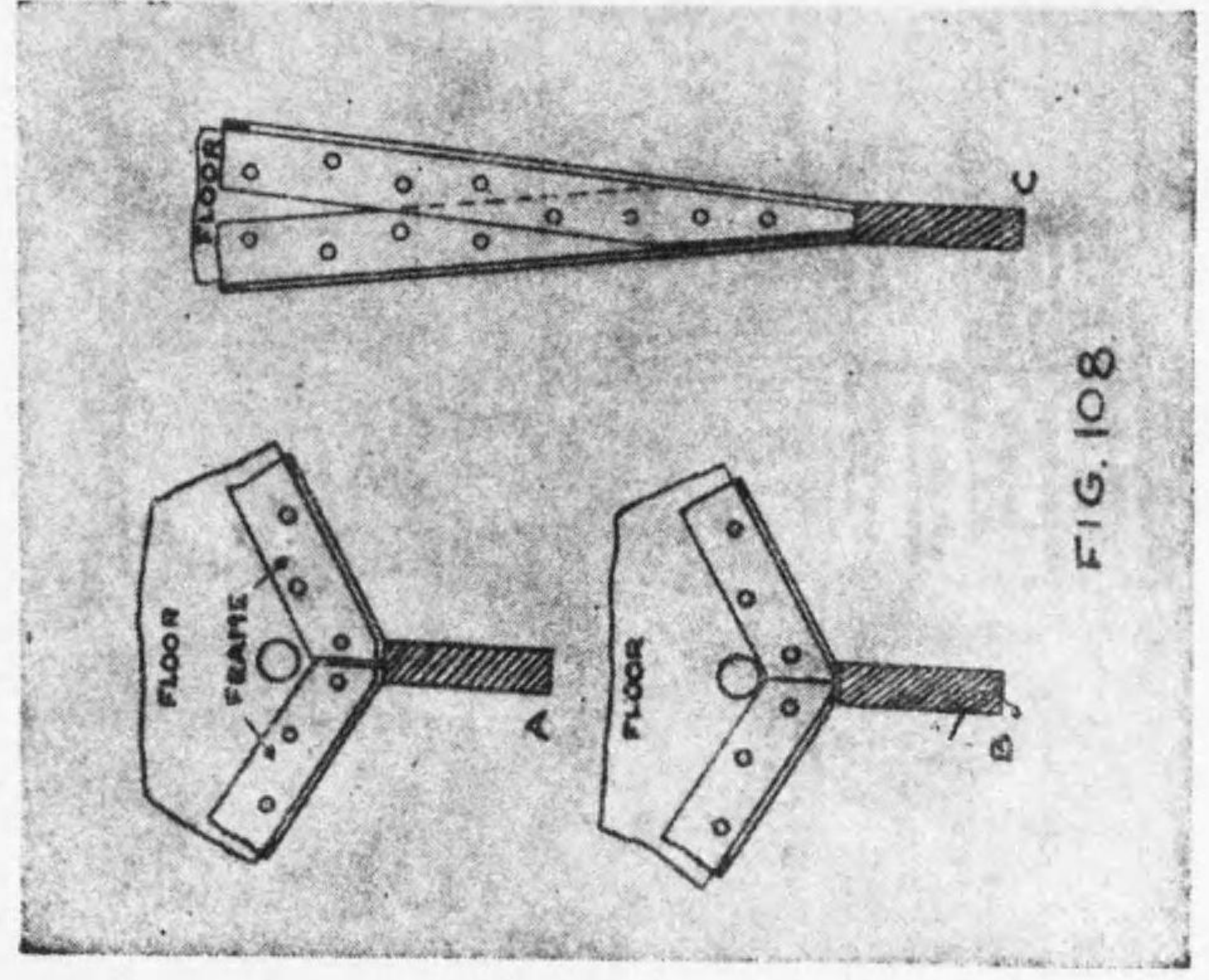
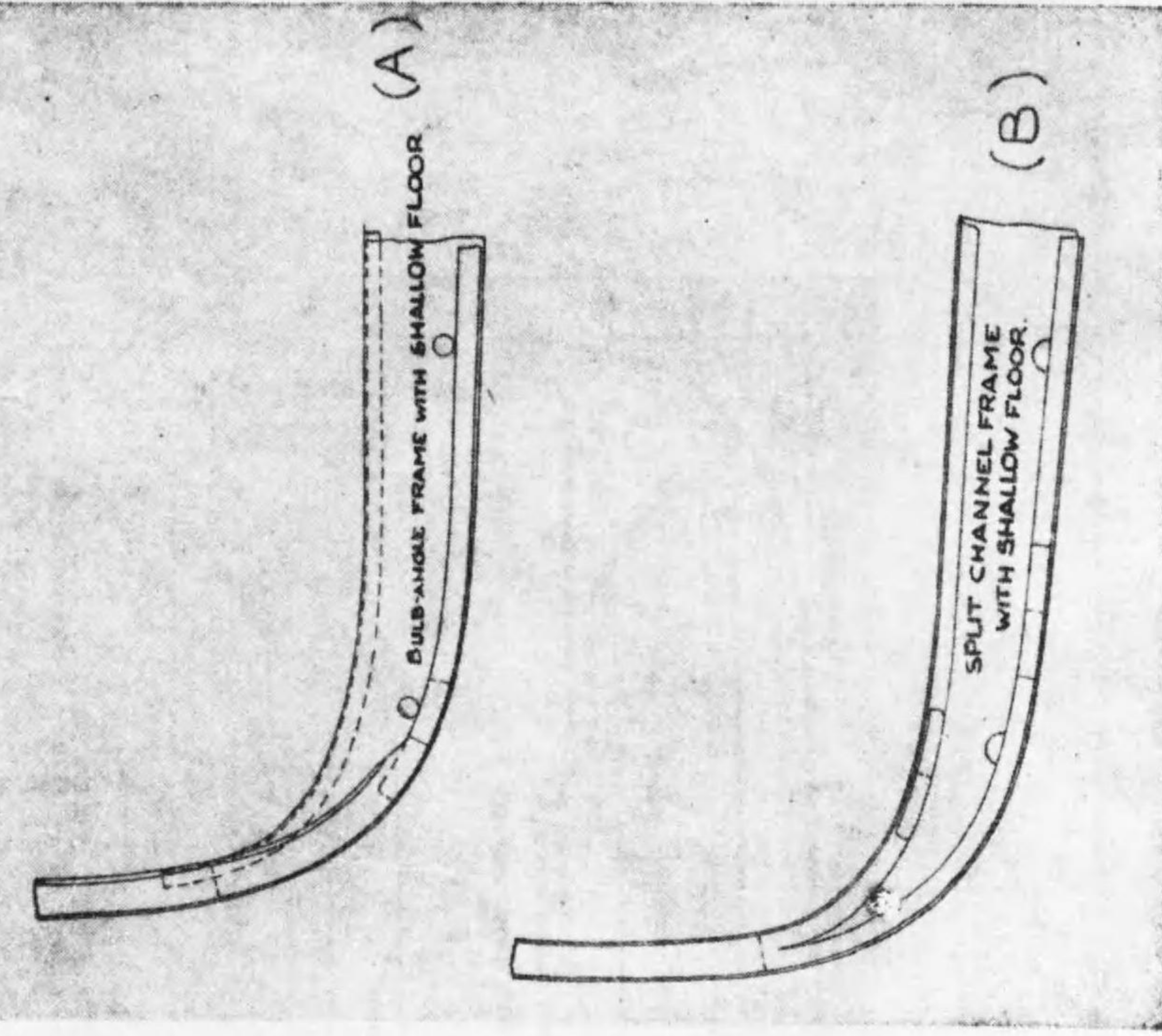
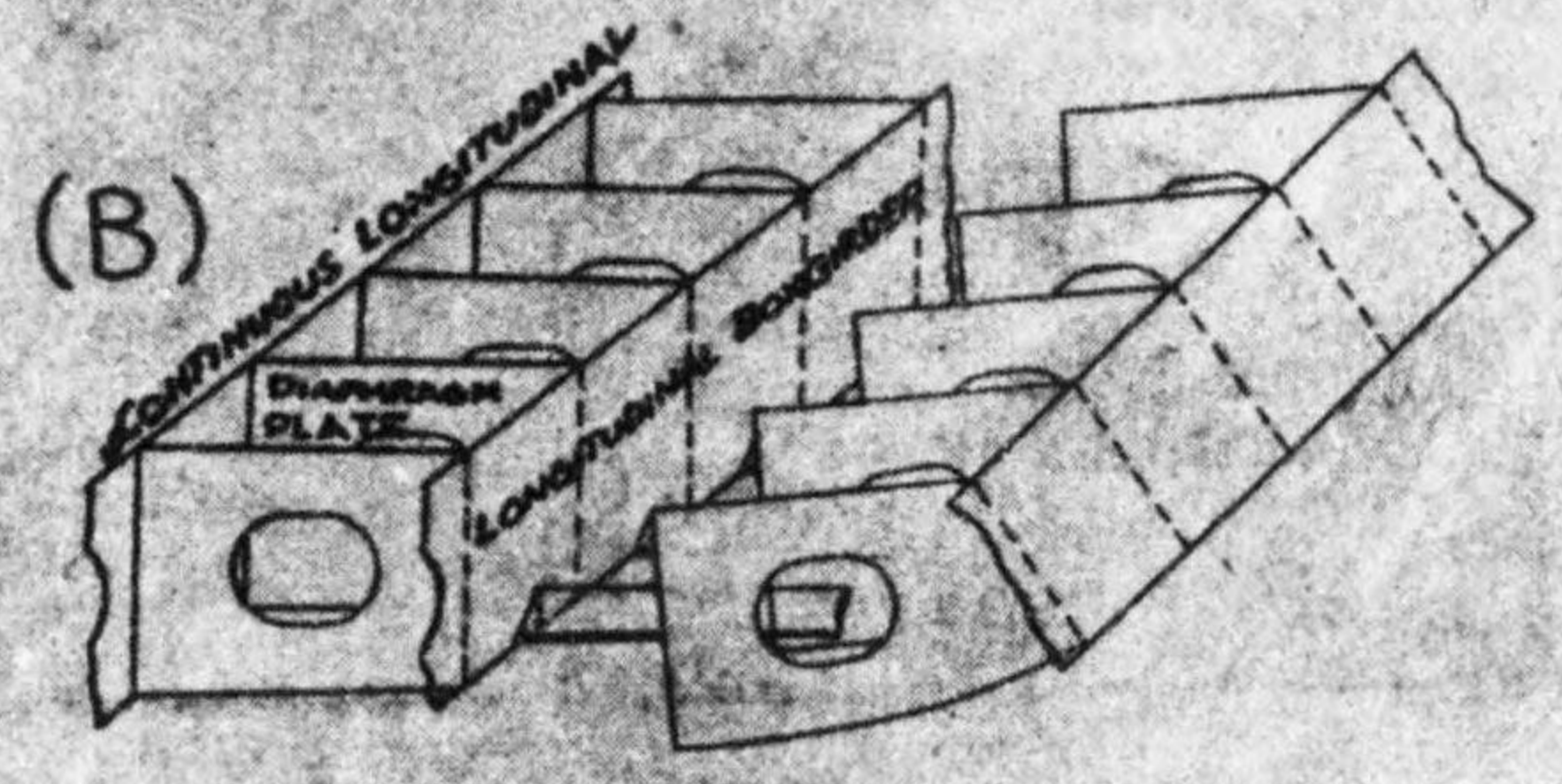
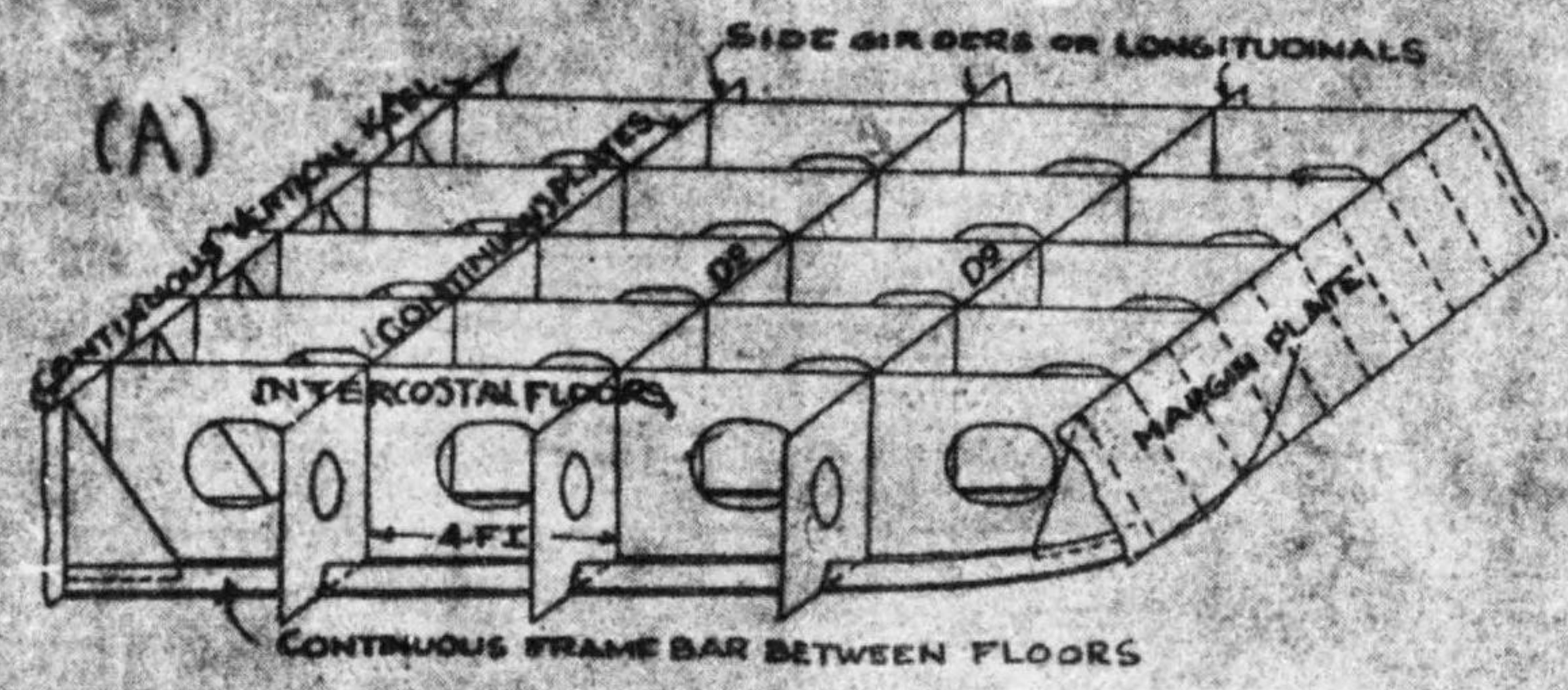

FIG. 108

FIG 110



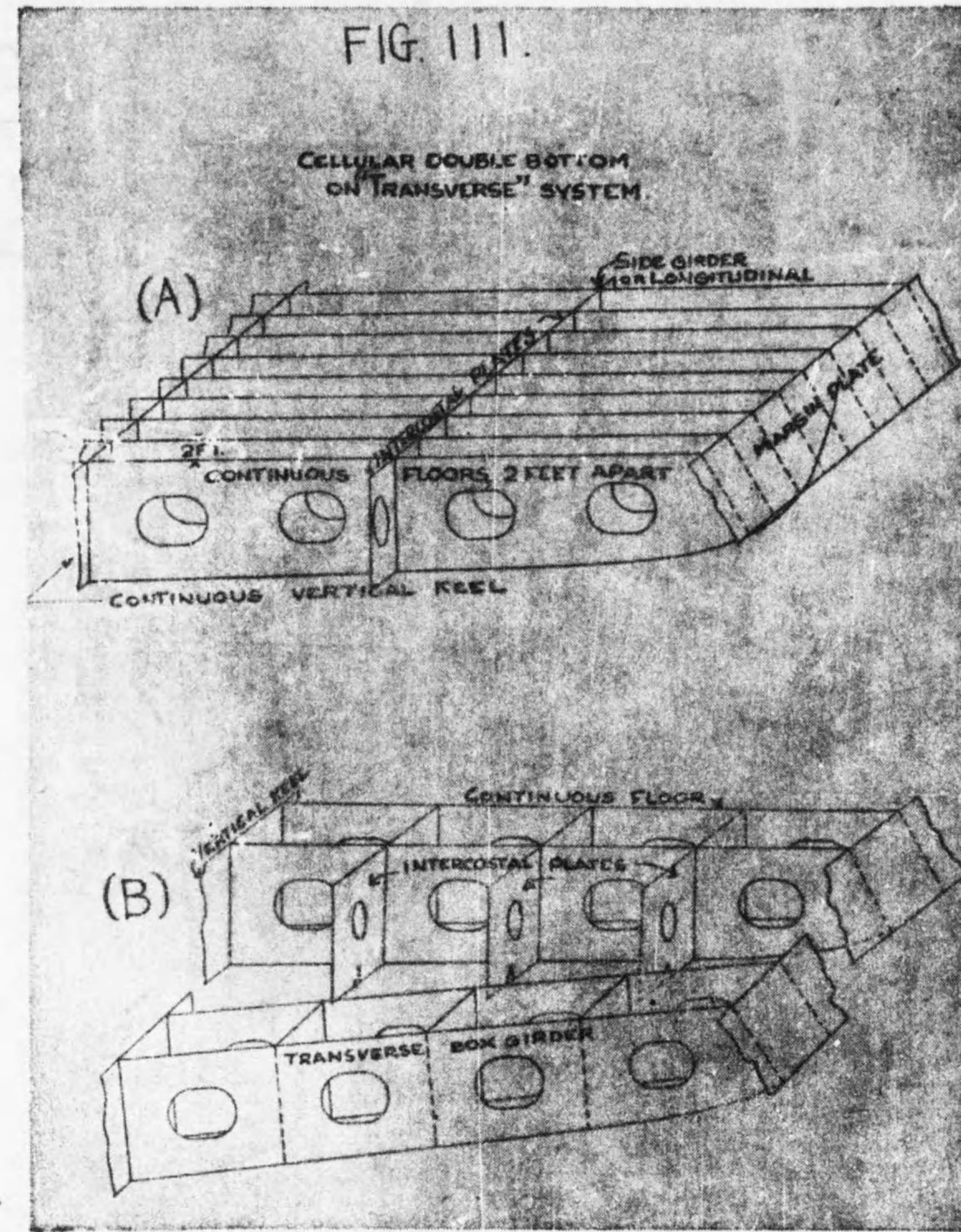
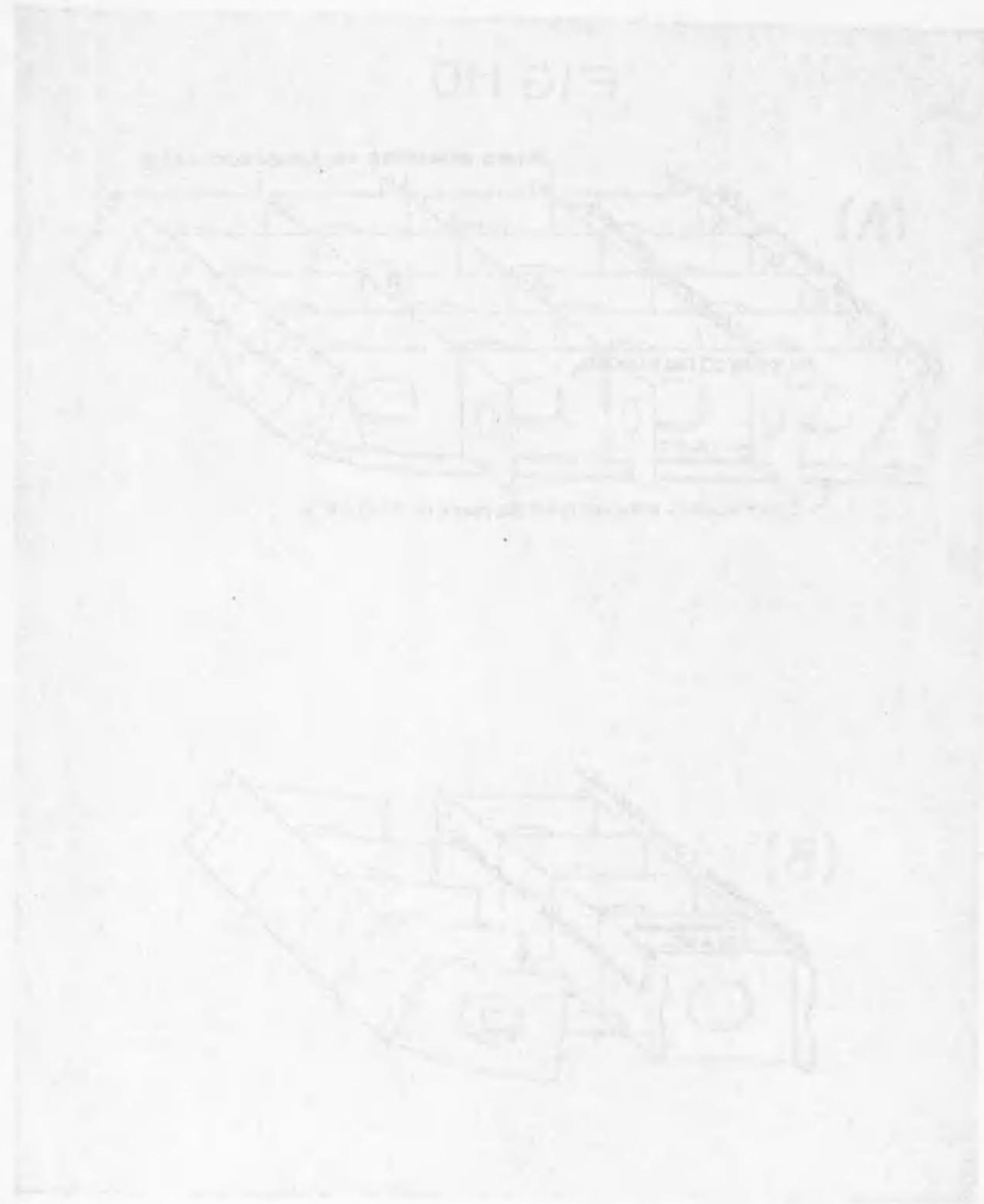

FIG. 112.

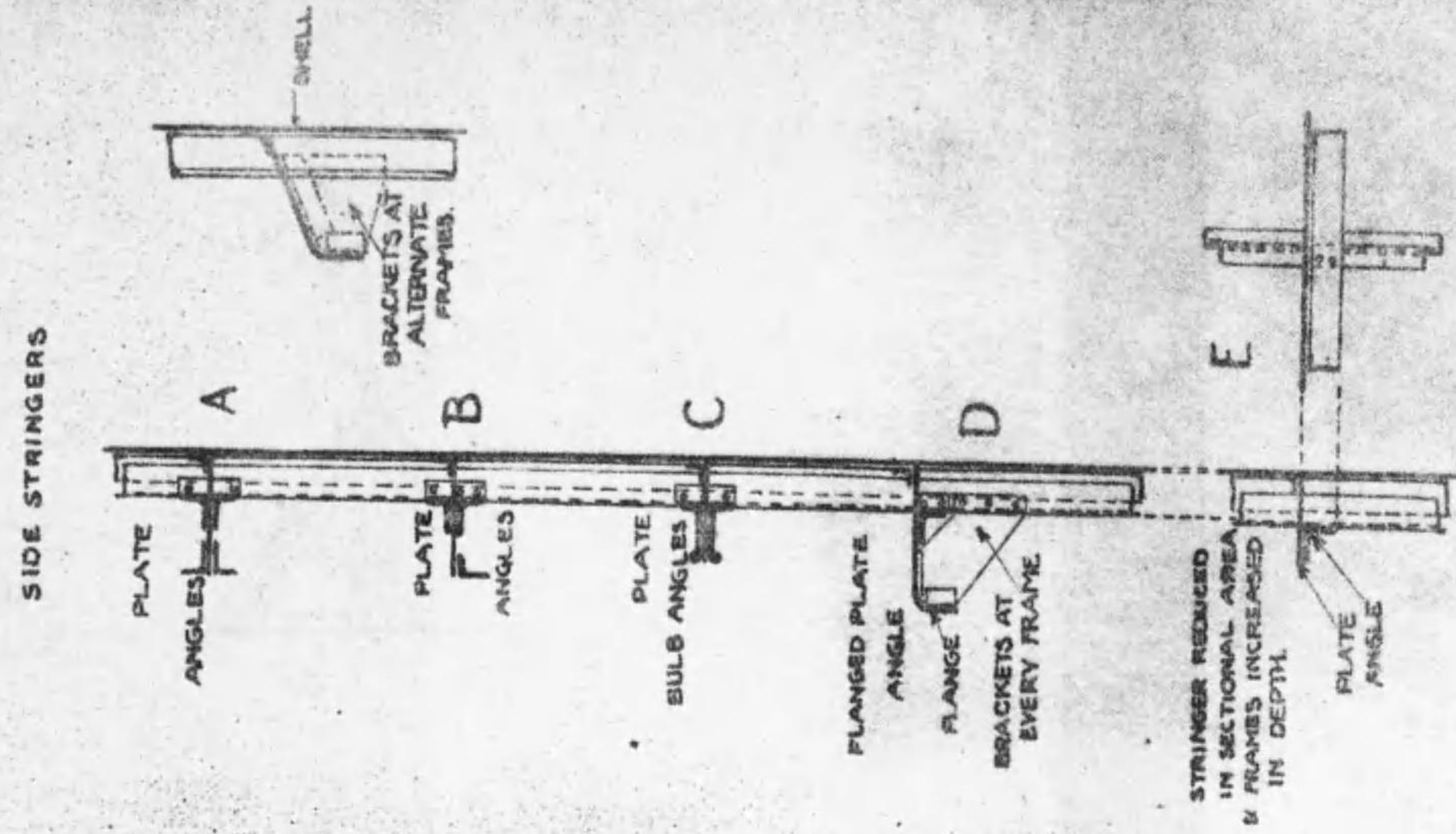
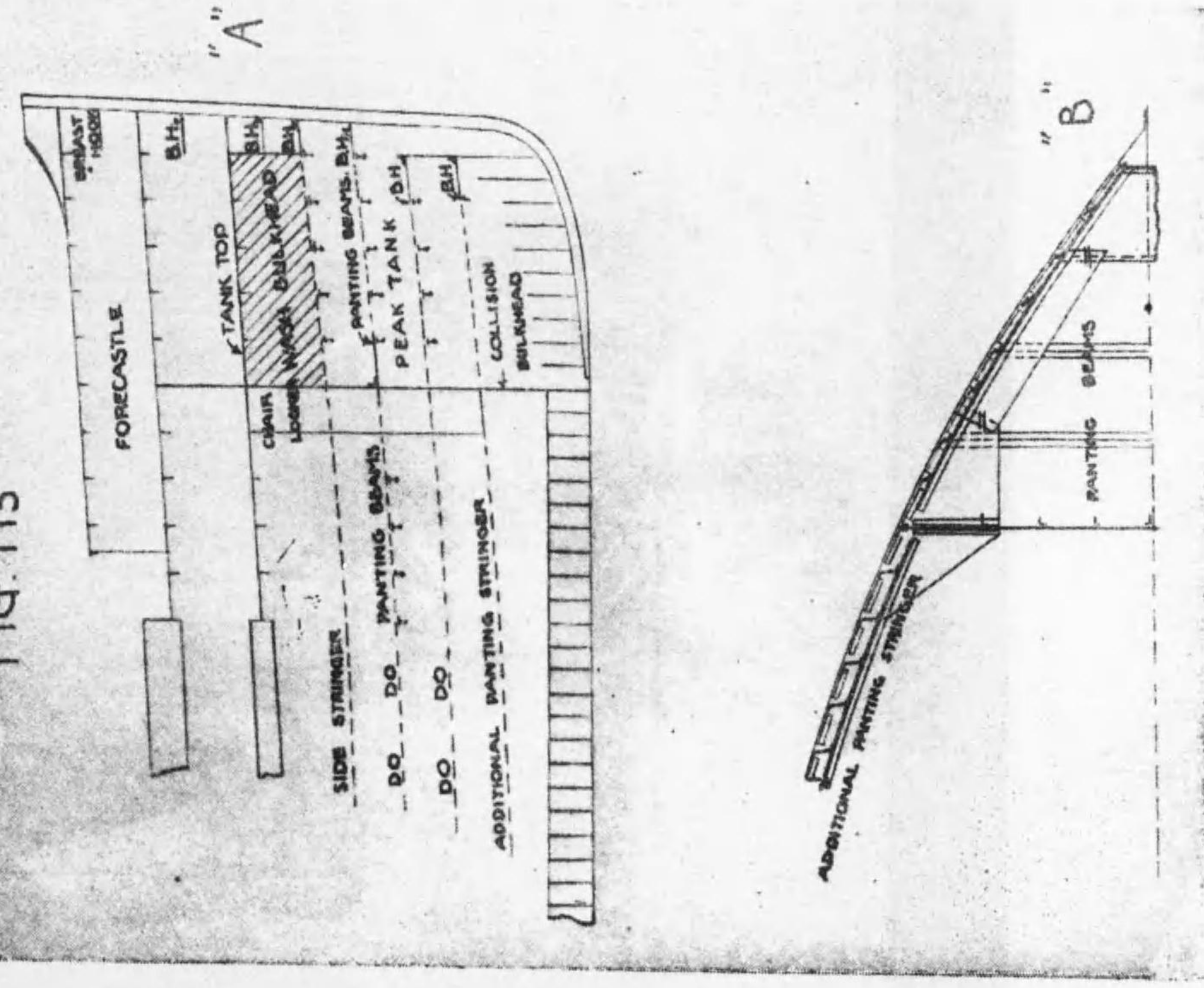

FIG. 113



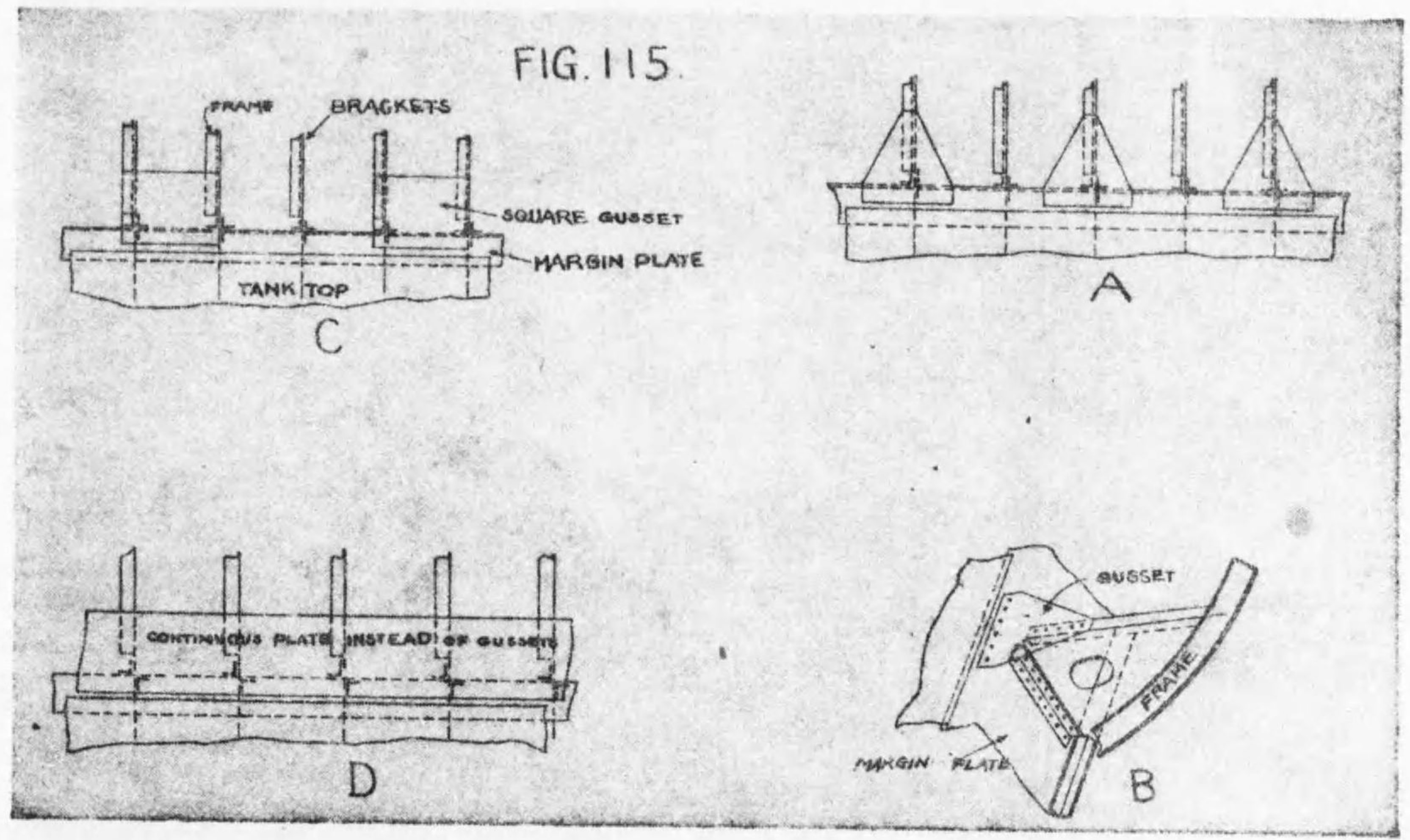
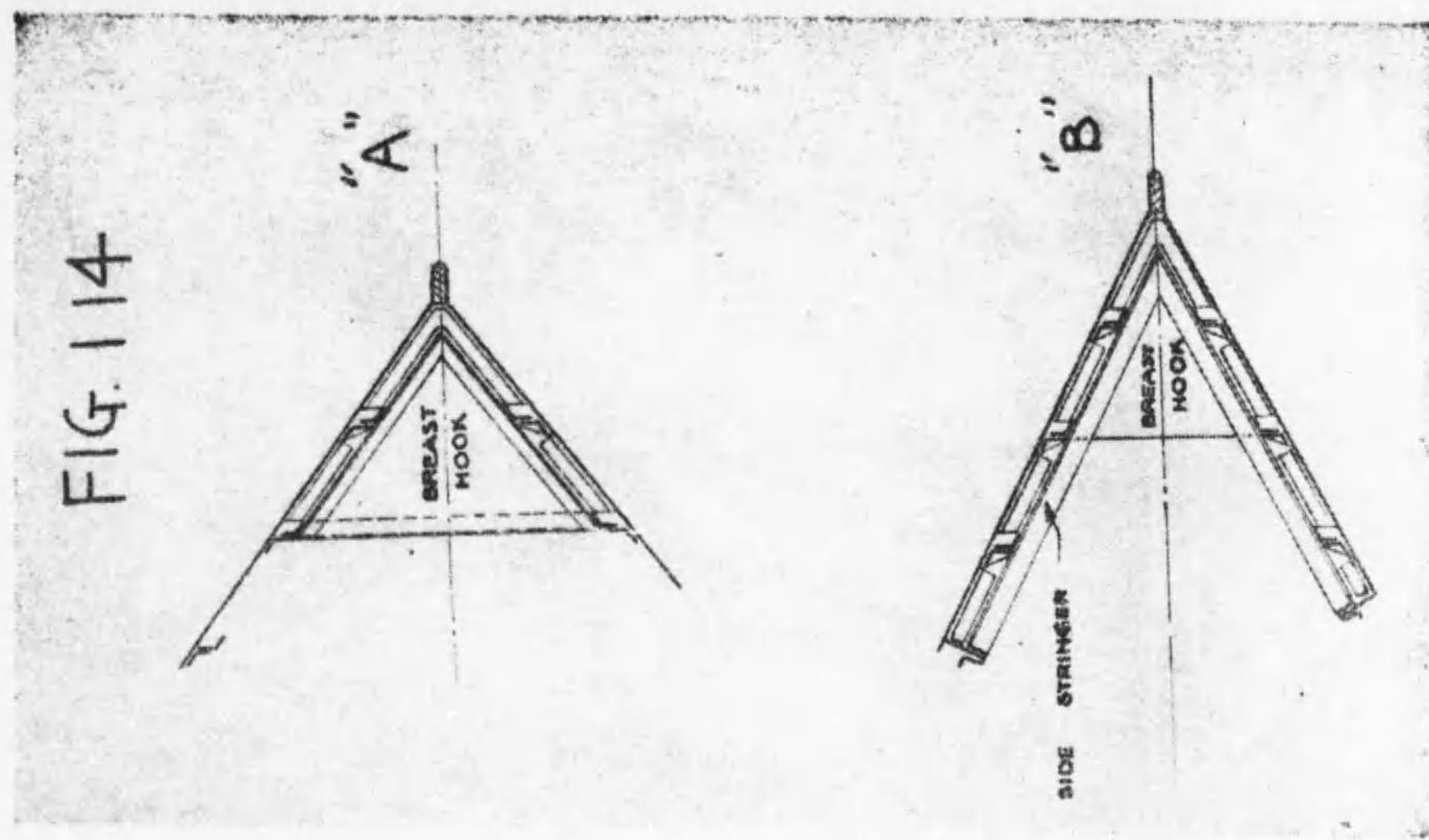

FIG 116 A PANTING STRINGER IN FORE PEAK TANK.

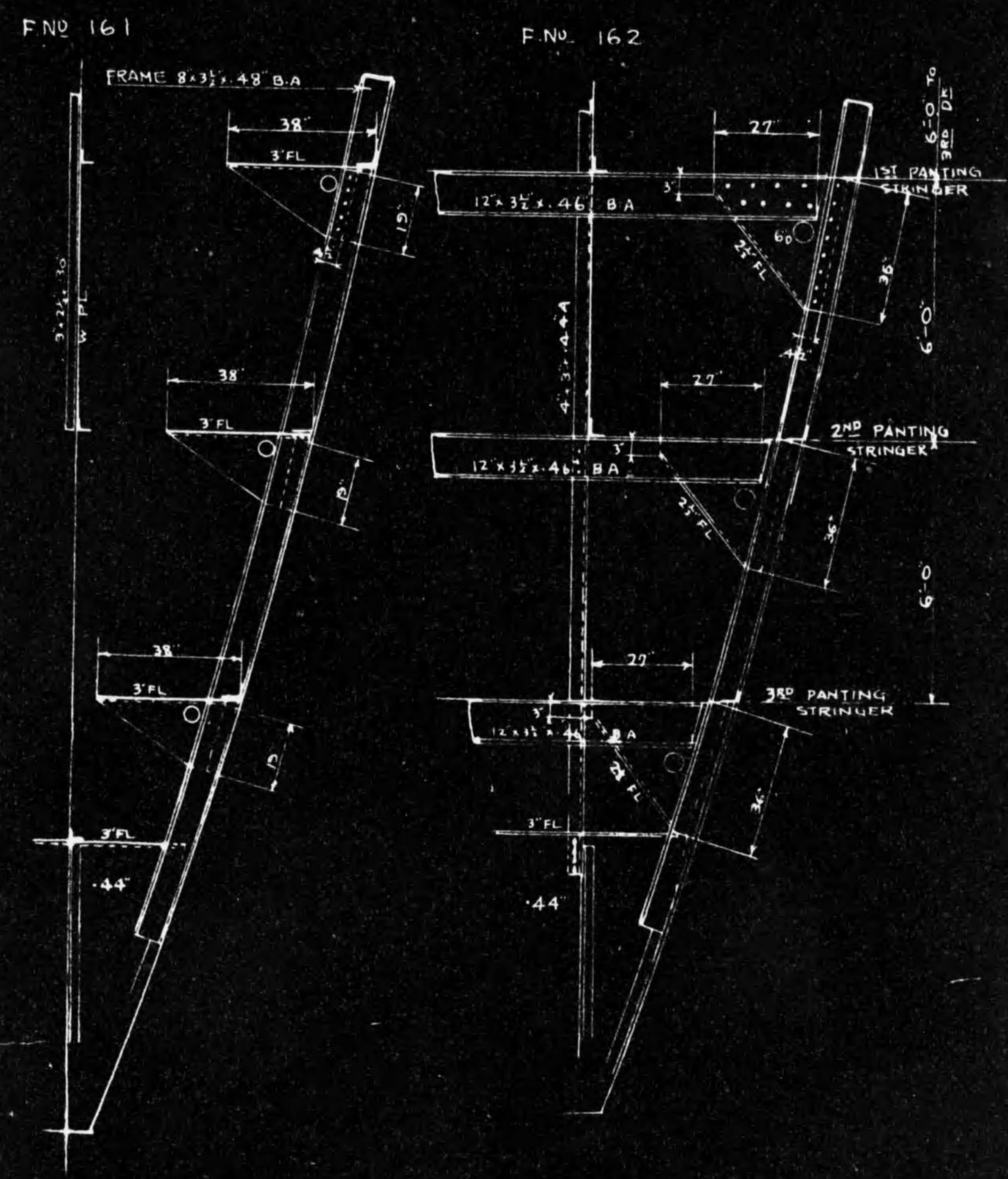

FIG 116 B

PANTING STRINGER IN FORE PEAK TANK

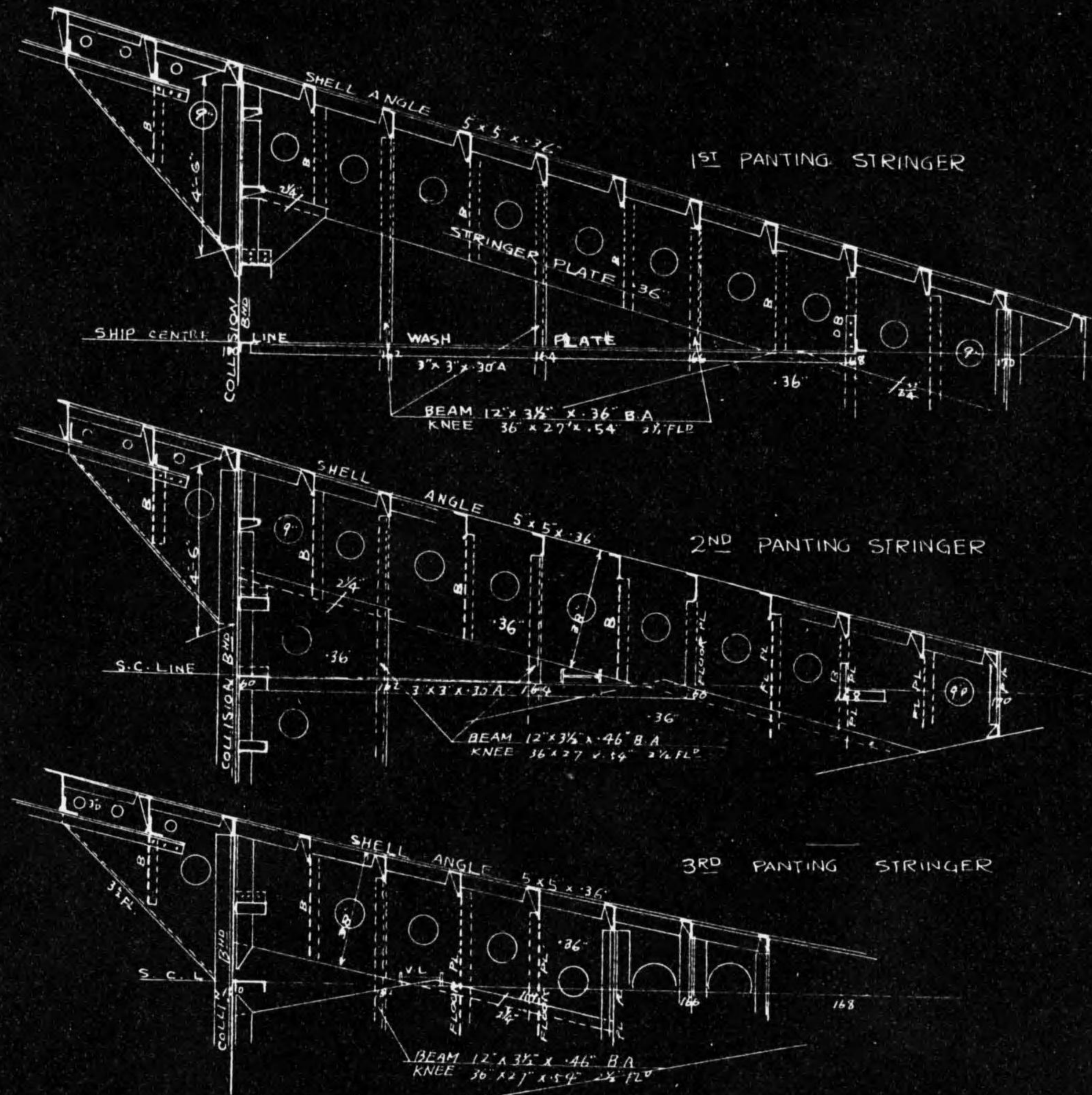
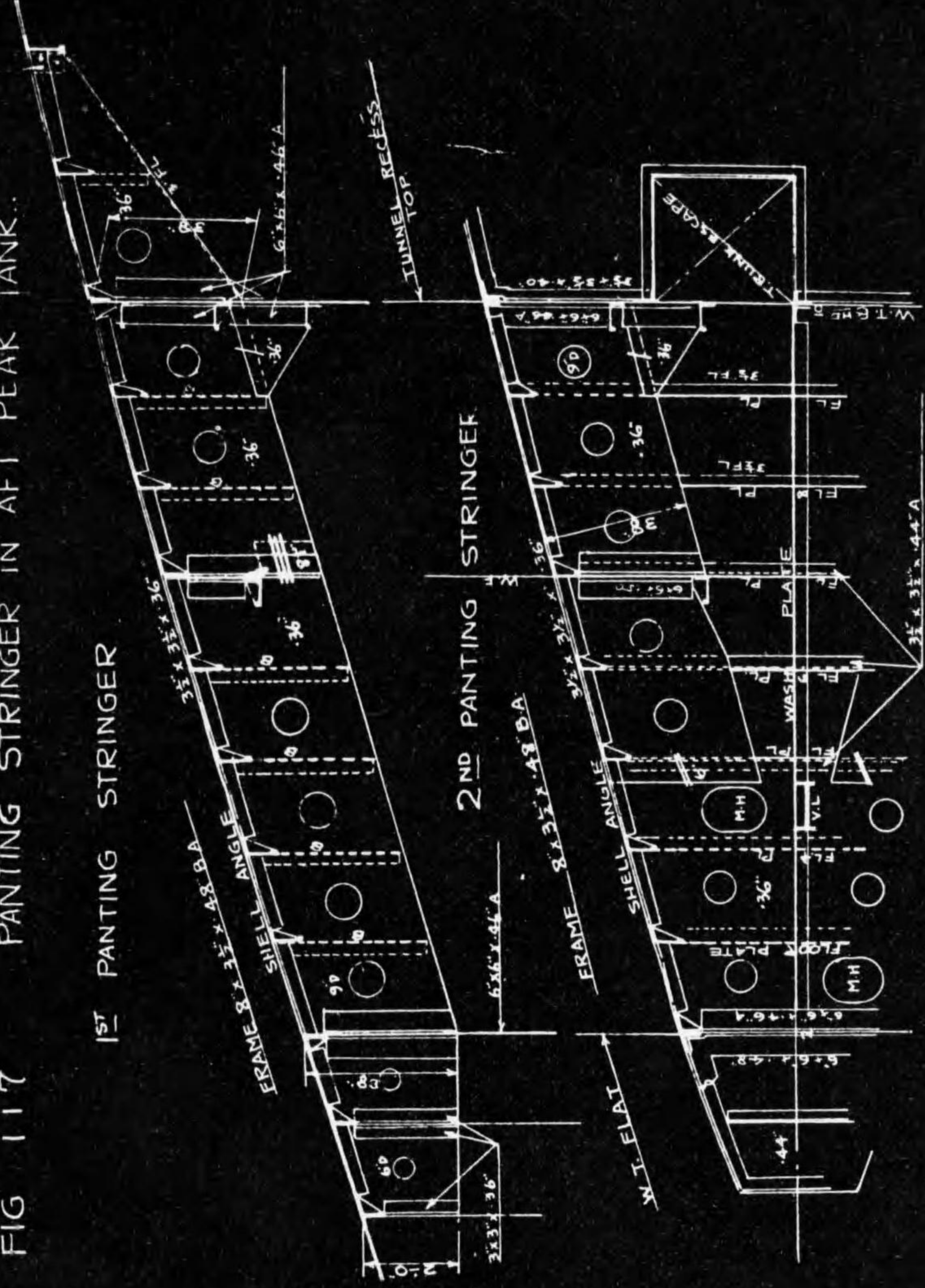

FIG 117 PANTING STRINGER IN AFT PEAK TANK

1ST PANTING STRINGER

2ND PANTING STRINGER



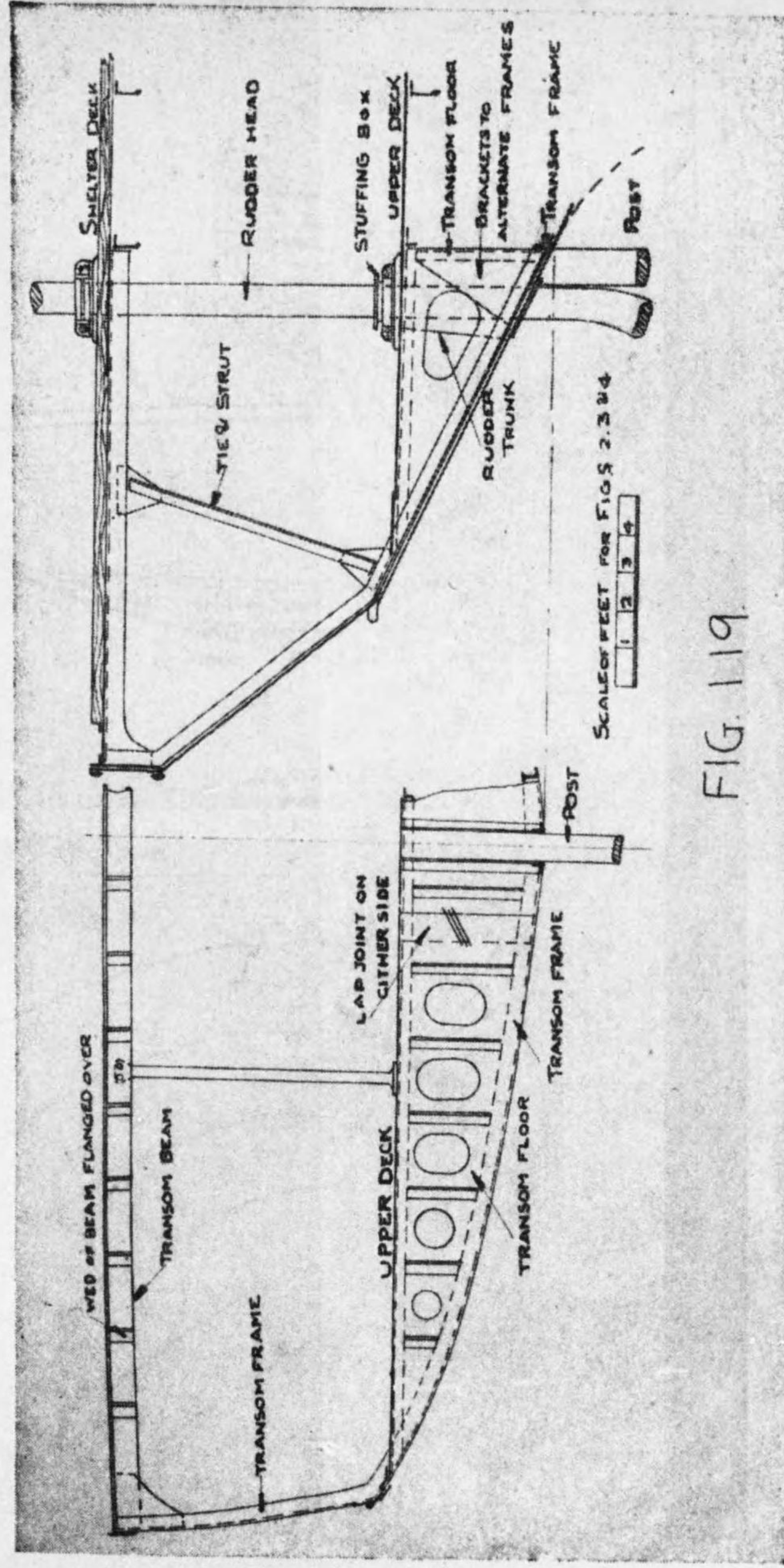

FIG. 119.

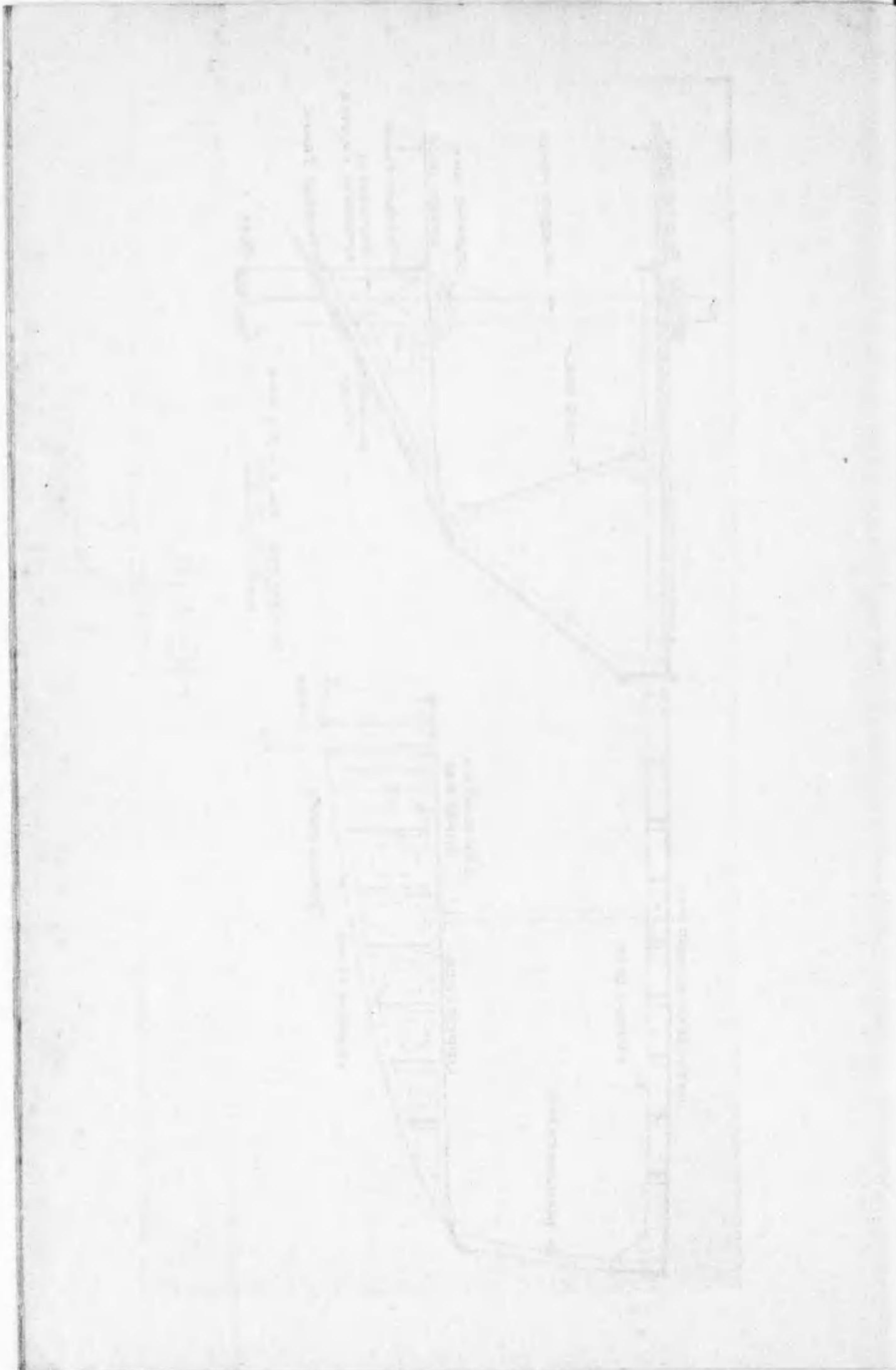

FIG. 120.

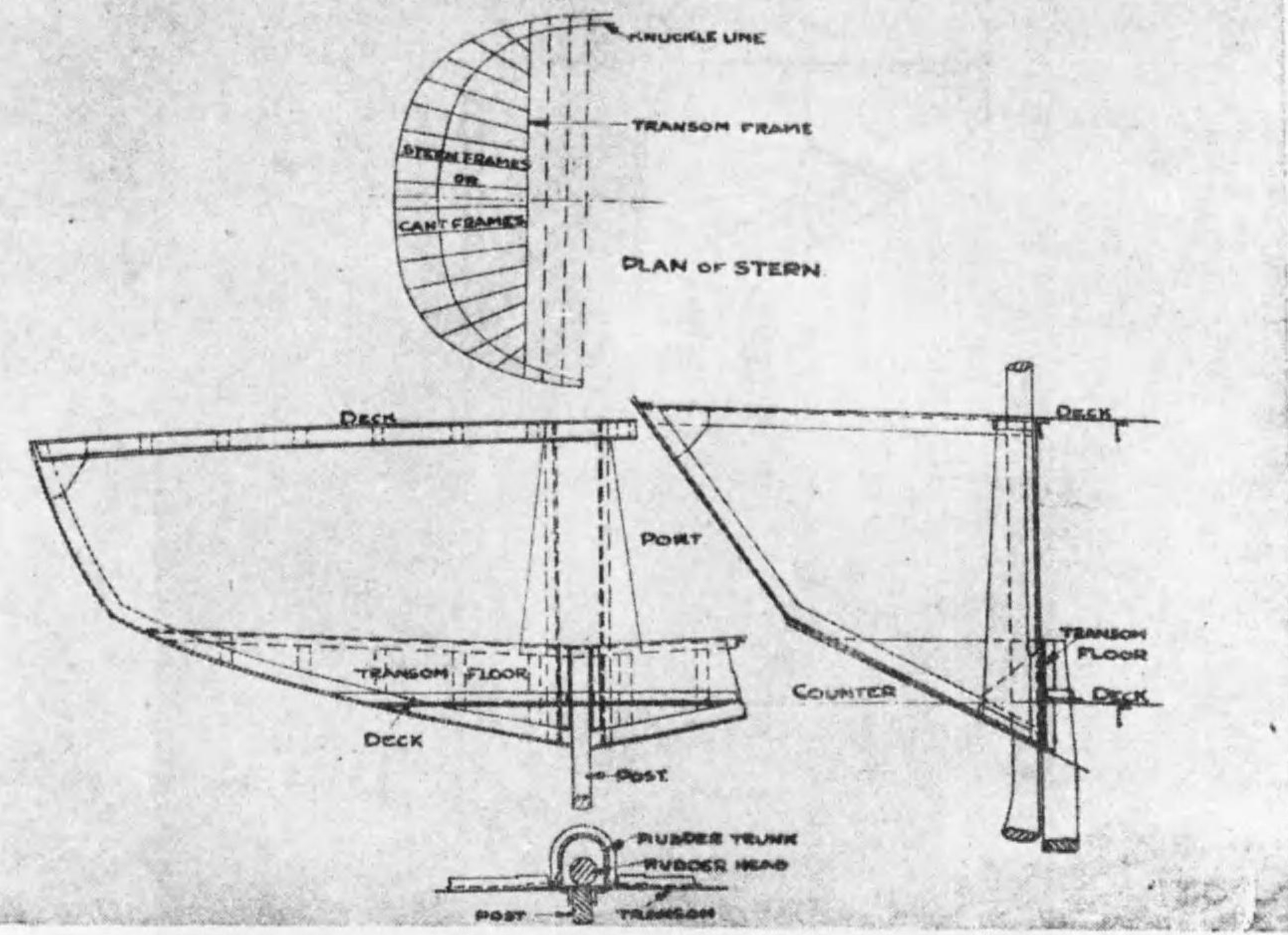

FIG 121

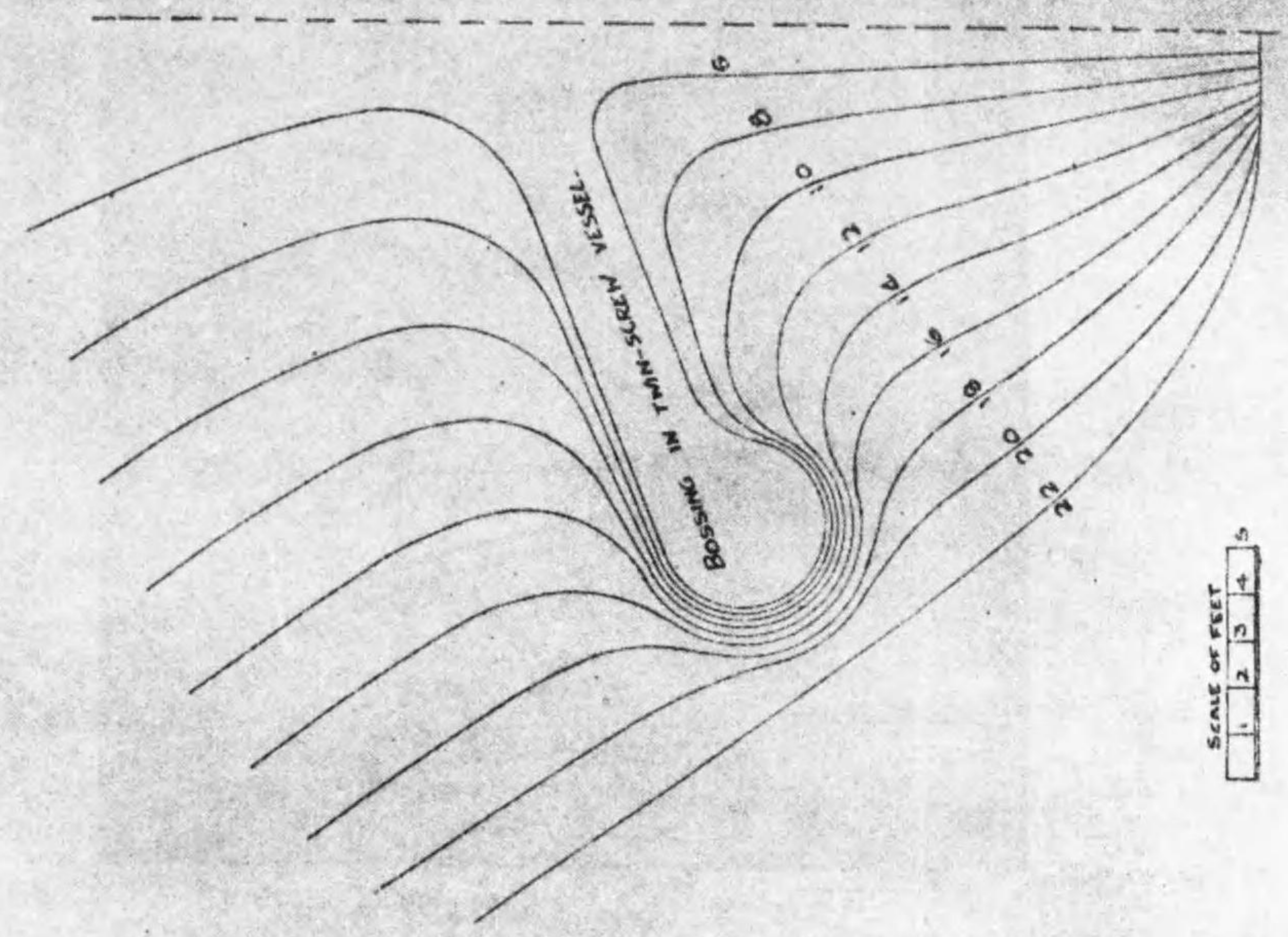



FIG. 123.

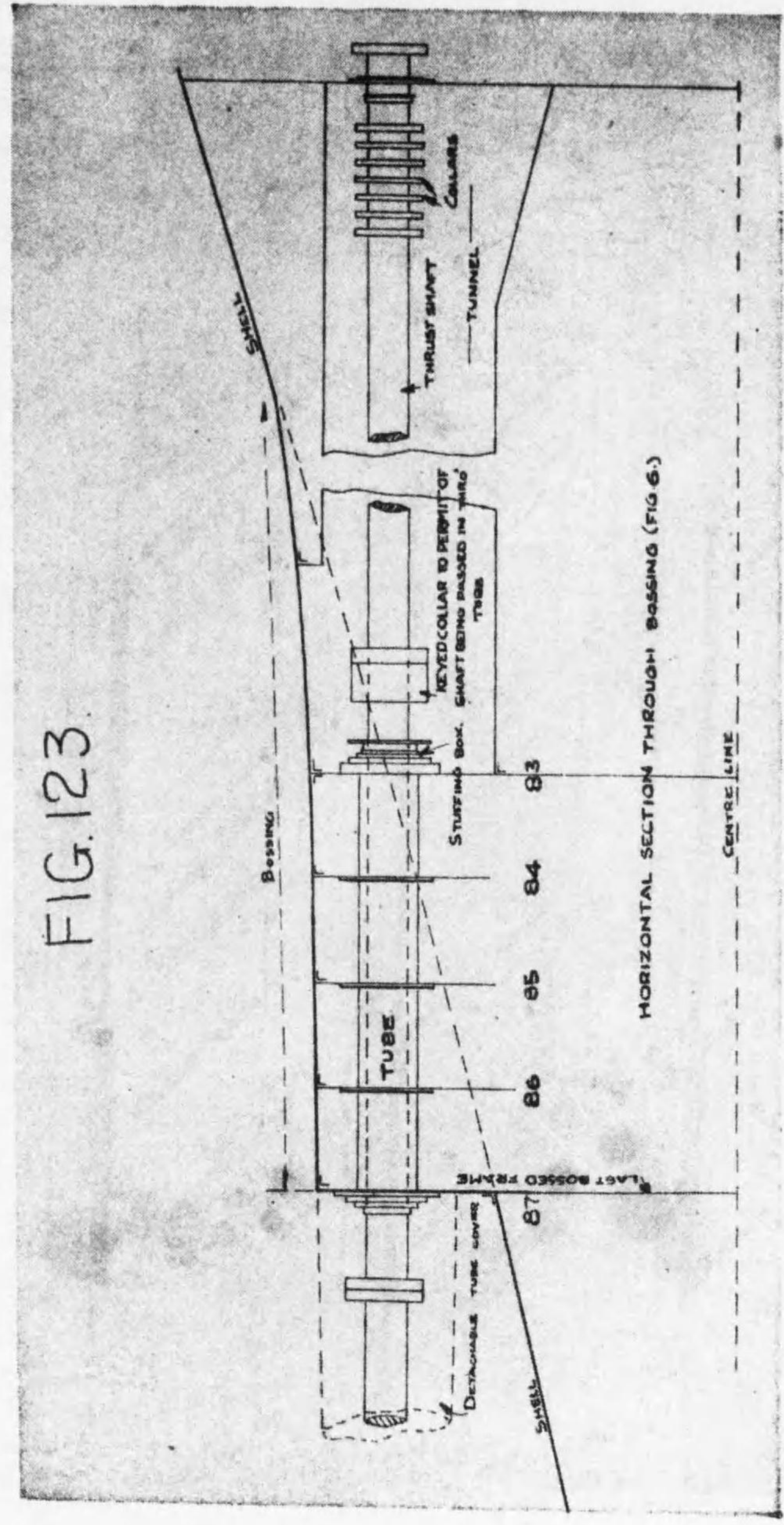
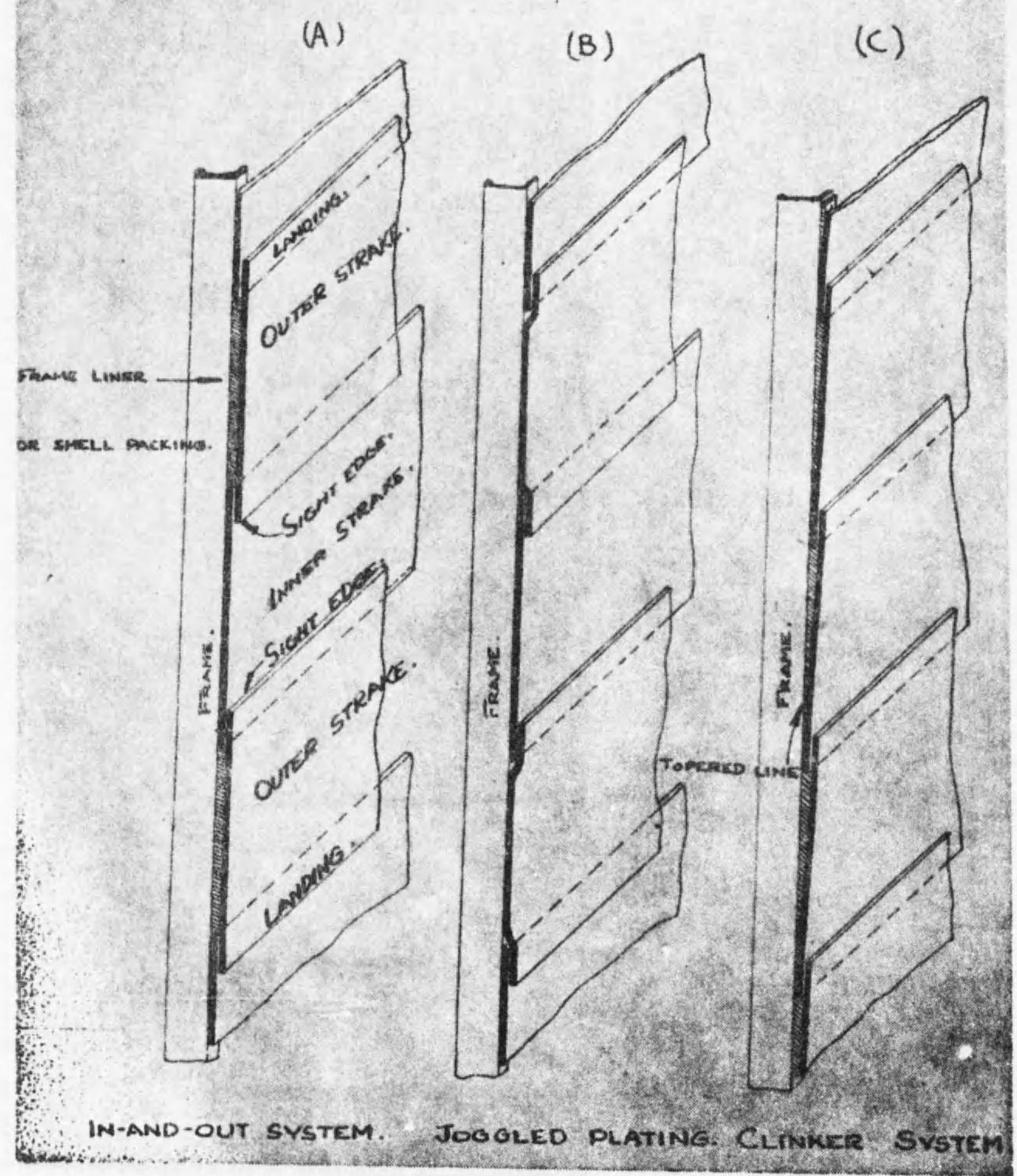



FIG. 124. I.



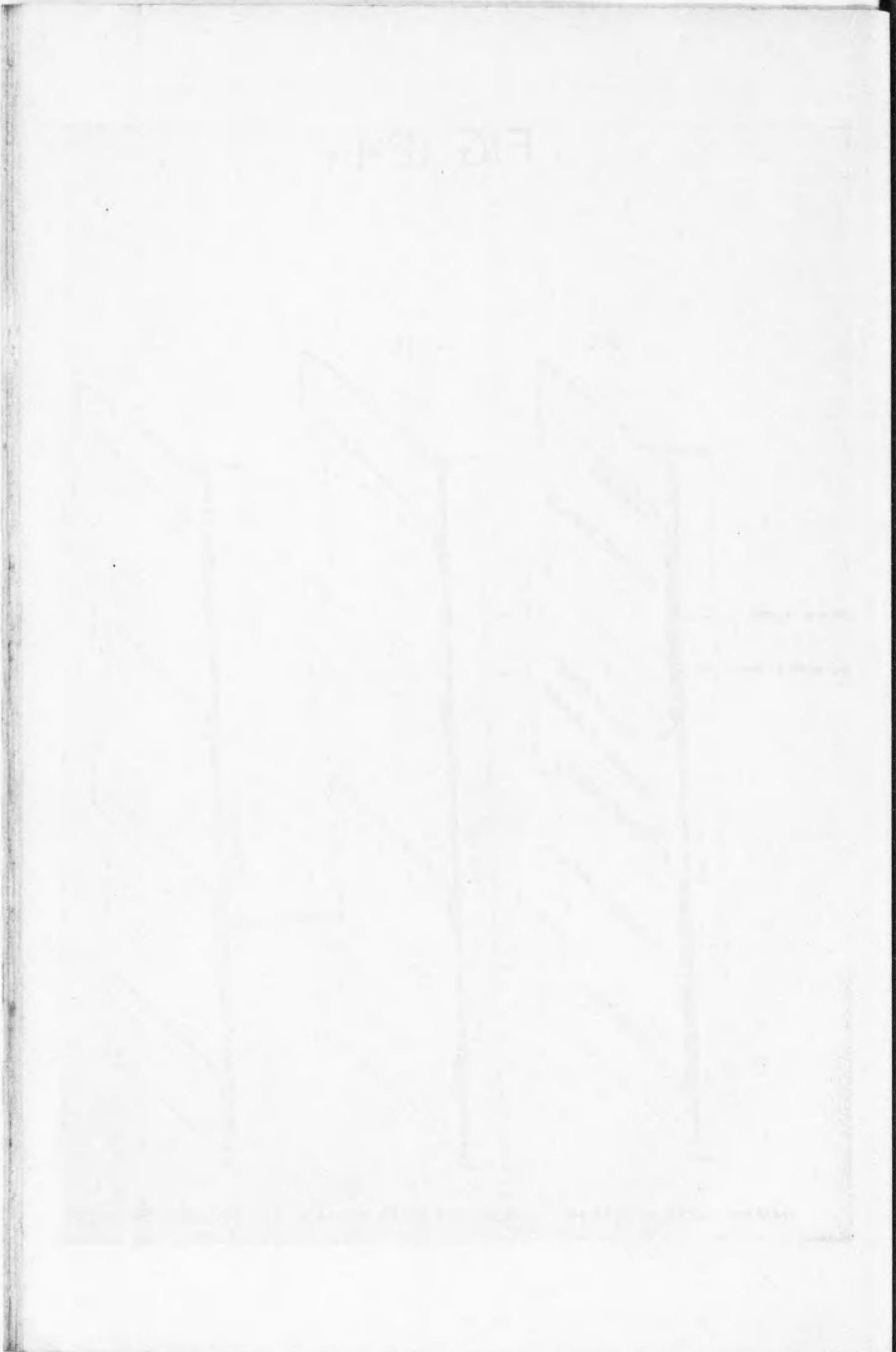

FIG. 124. II.

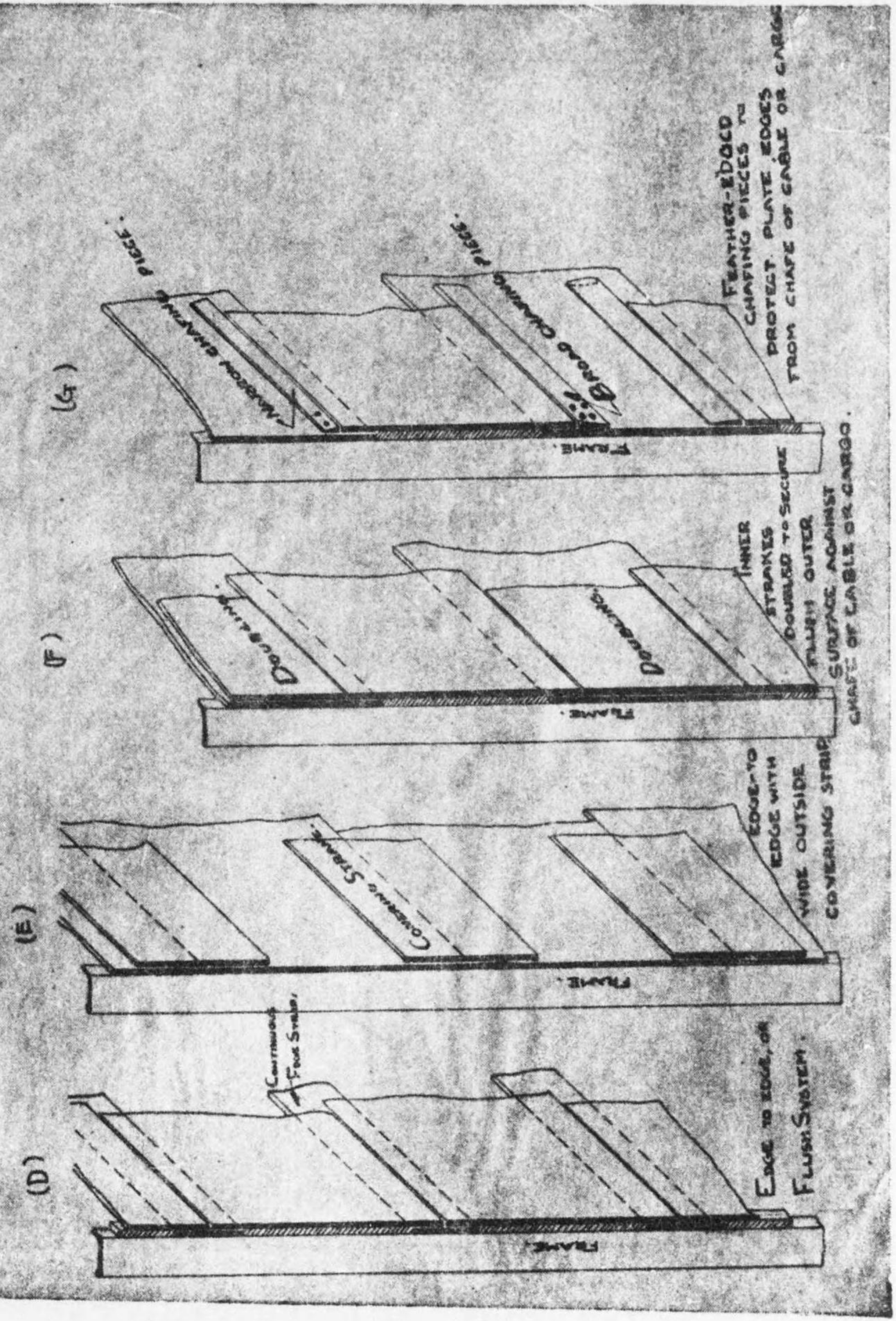

FIG 125.

(A)



(B)

B I L G E K E E L S

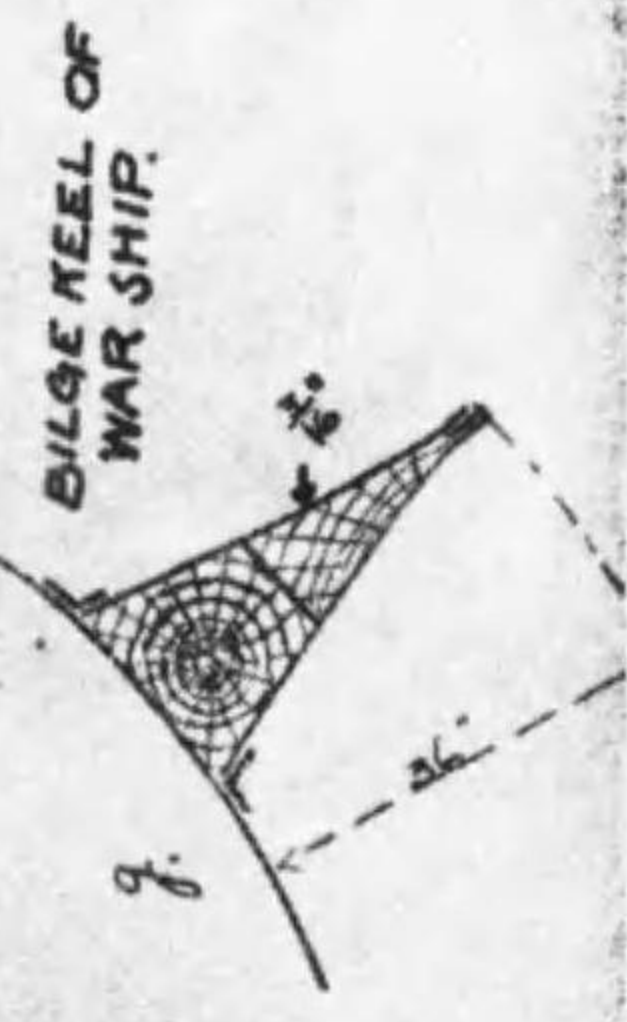

TOGGLED FRAME

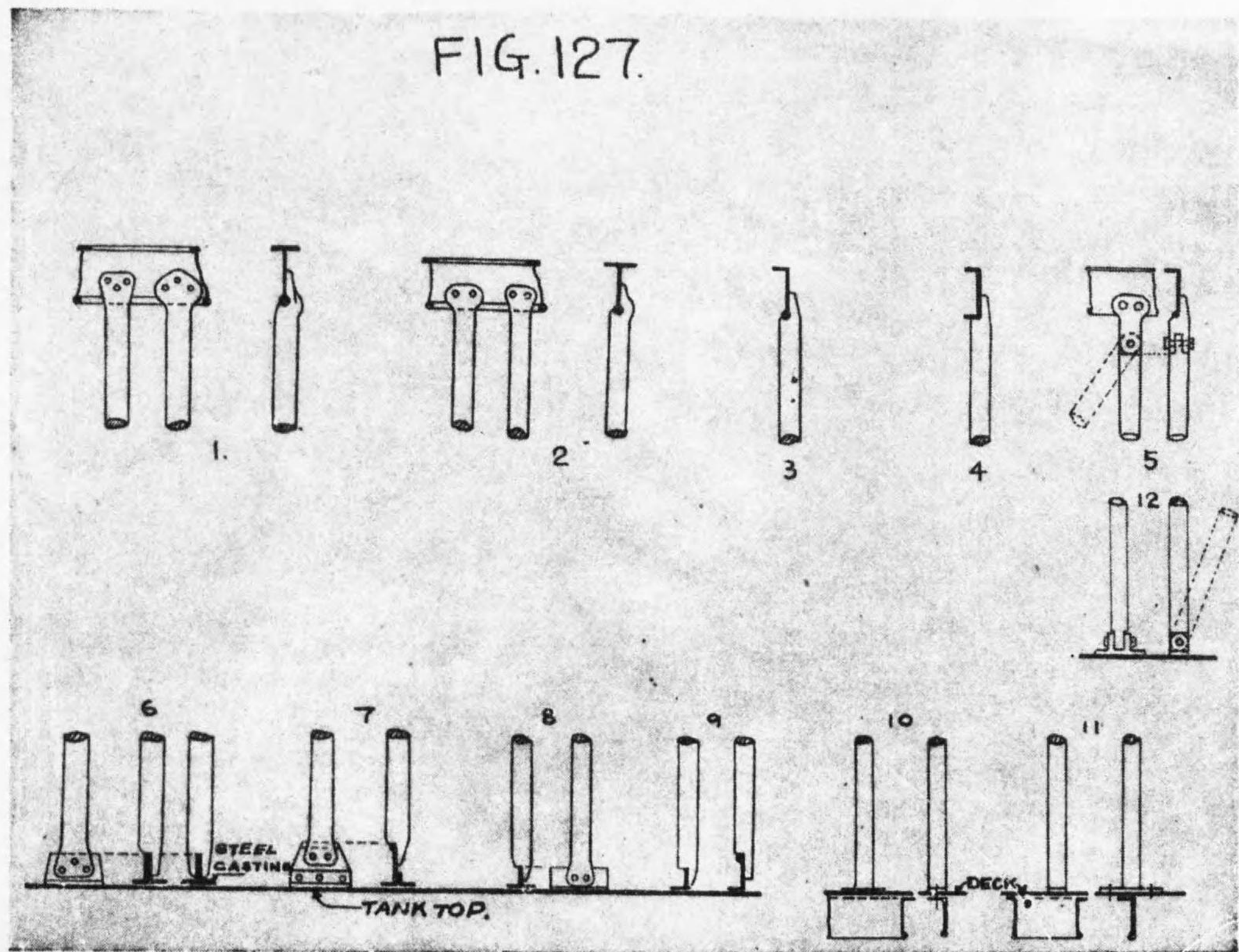
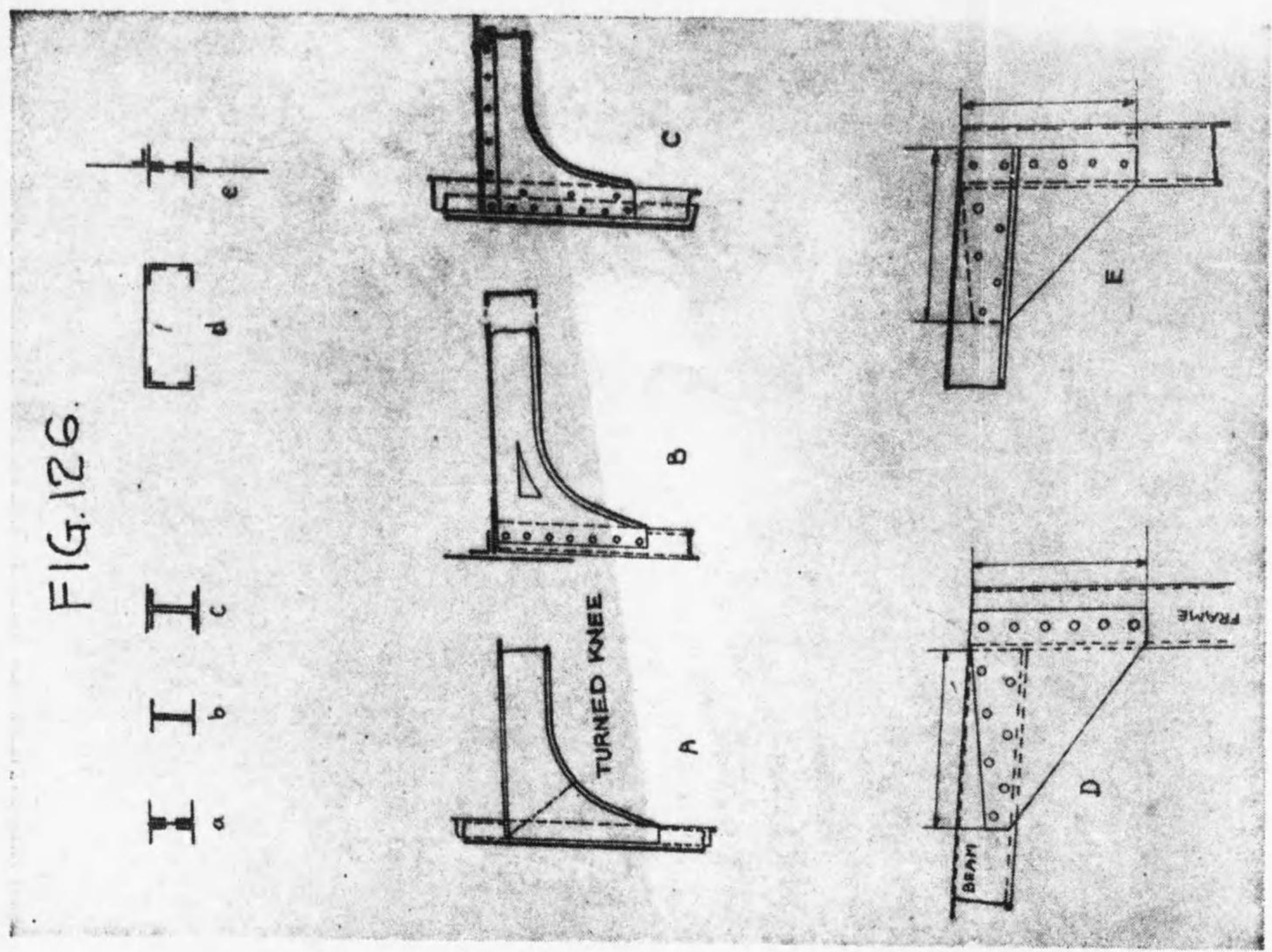
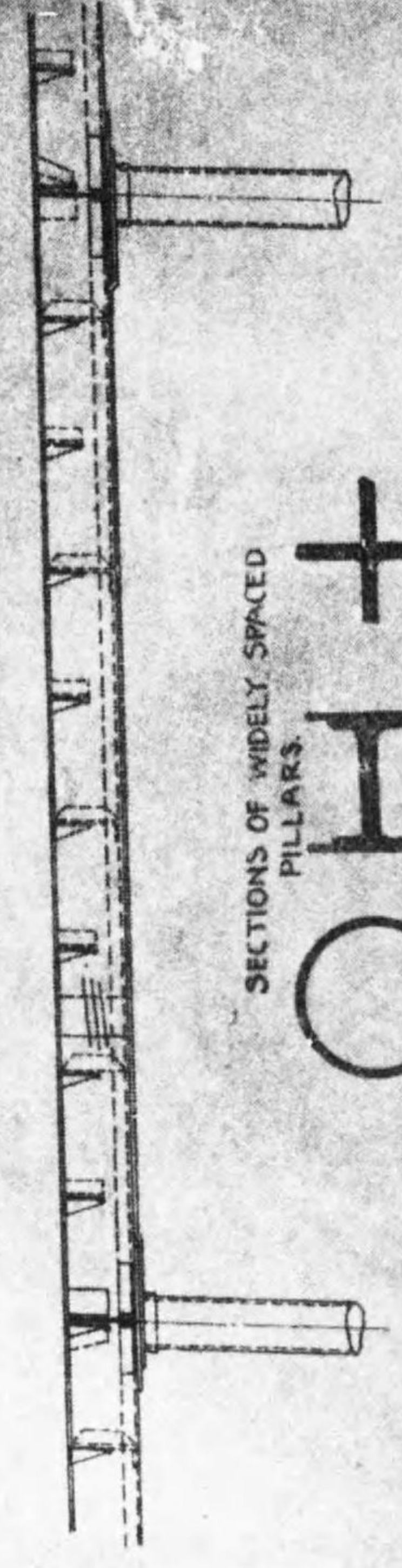
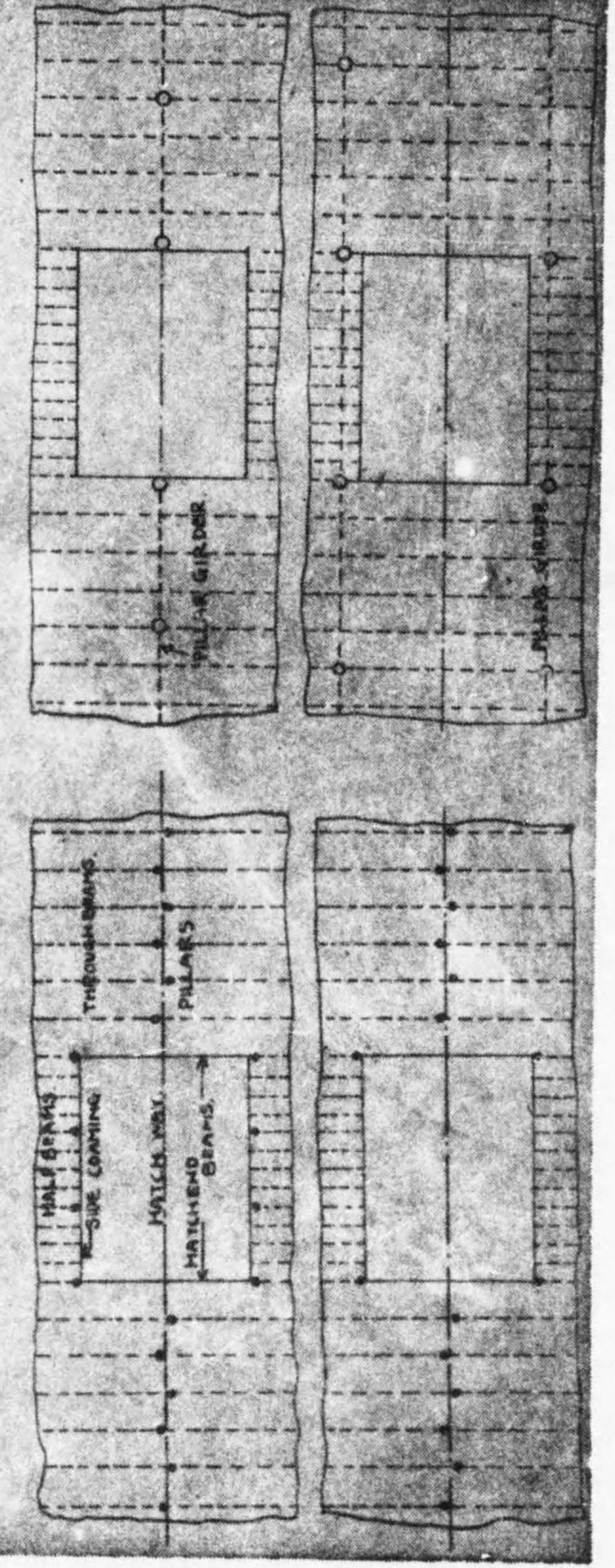



FIG. 128



SECTIONS OF WIDELY SPACED
PILLARS.



A CARGO STEAMER.

274'-0" x 40'-3" x 22'-6"

GENERAL ARRANGEMENT

FIG 129

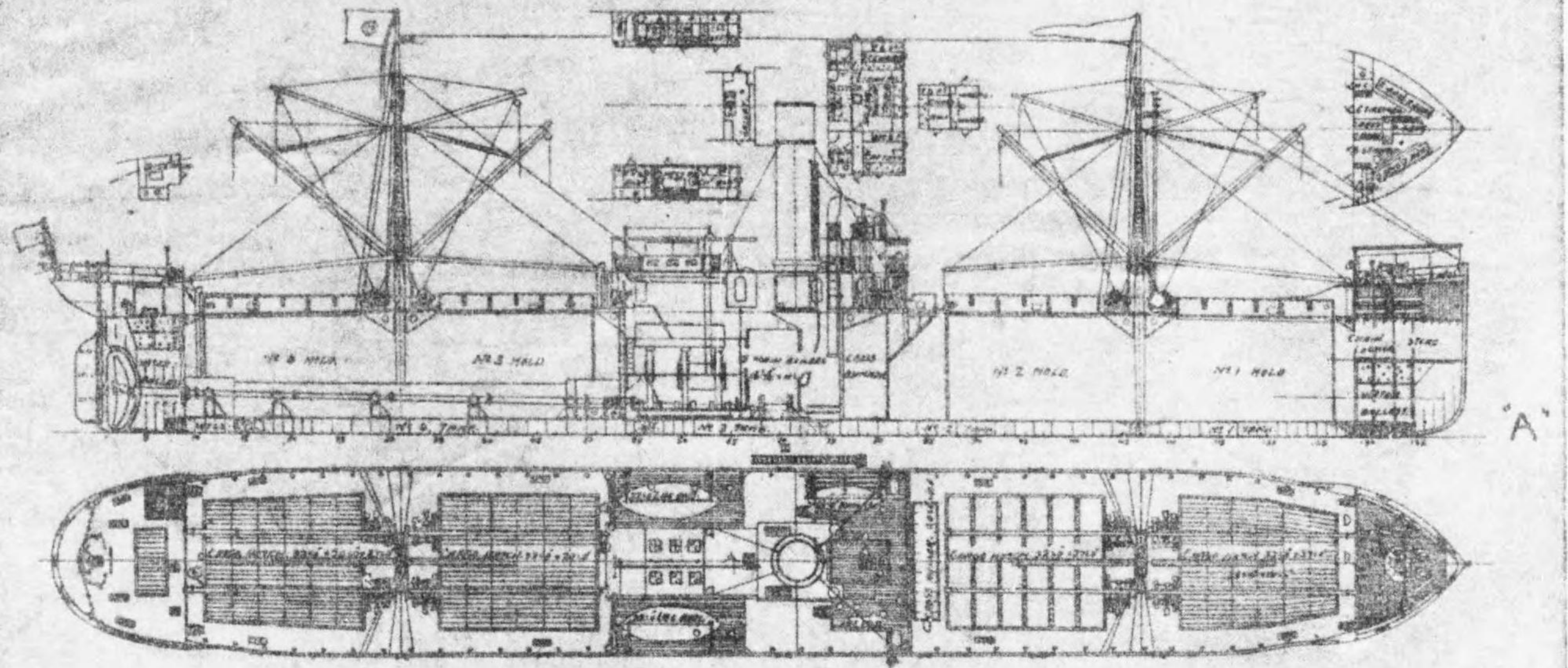

CONSTRUCTION PROFILE AND DECK PLAN.

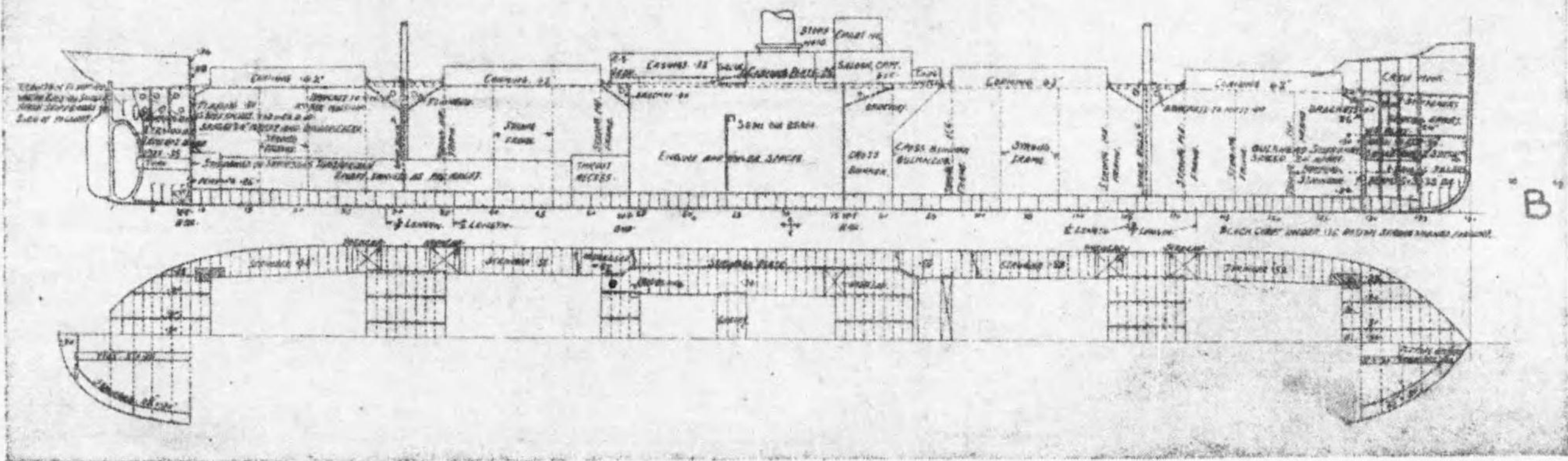

FIG. 130

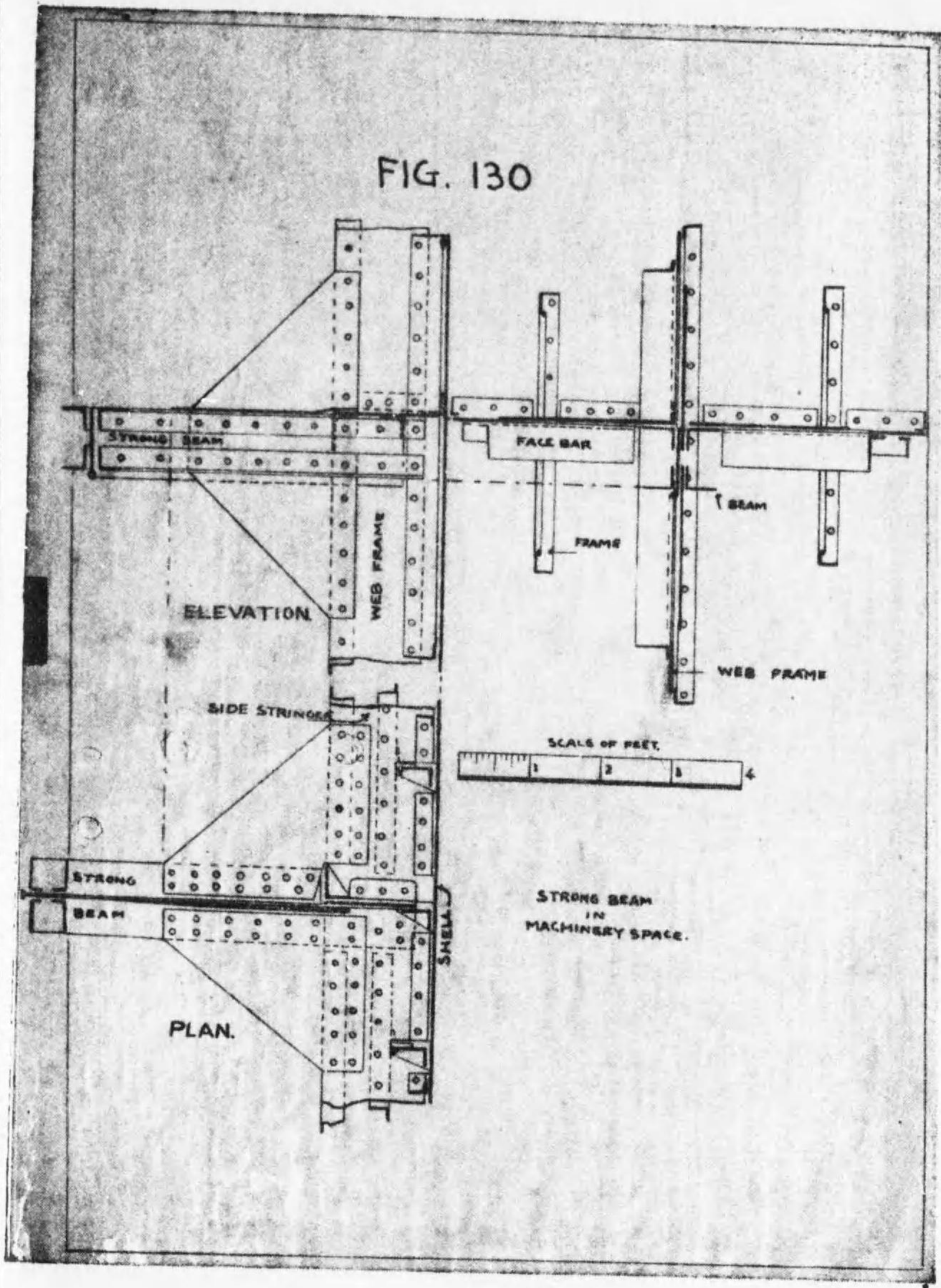
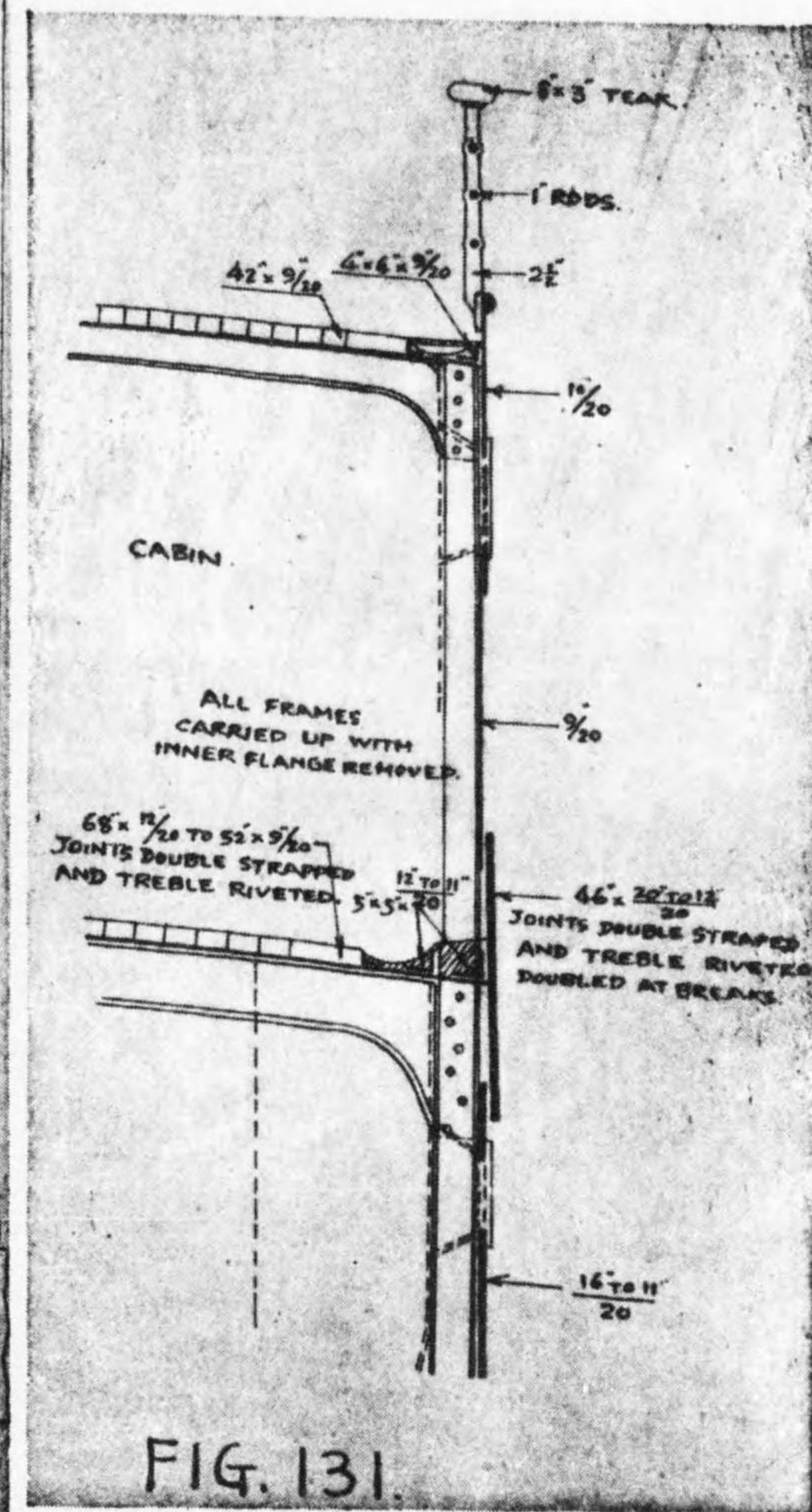
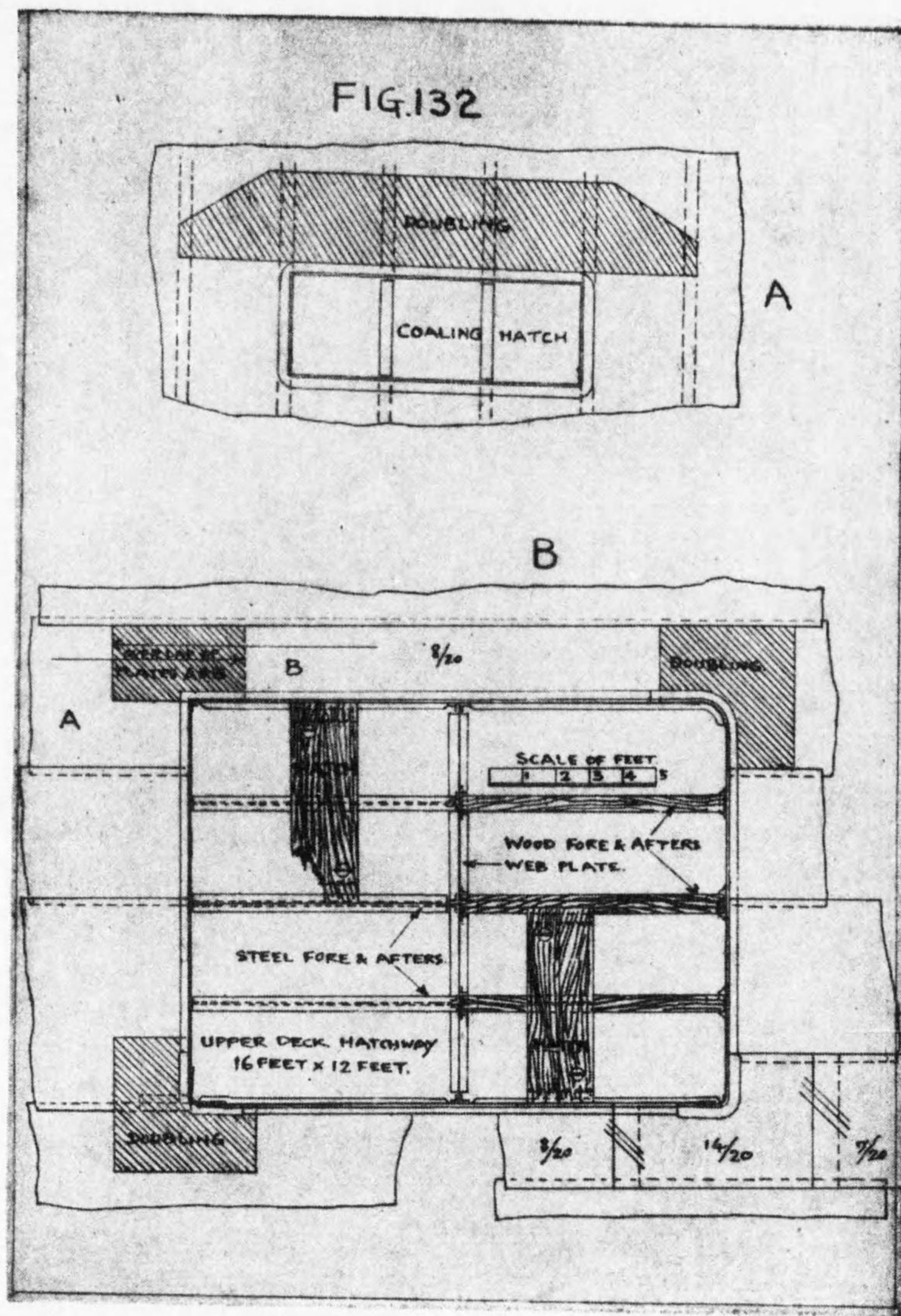

FIG. 132



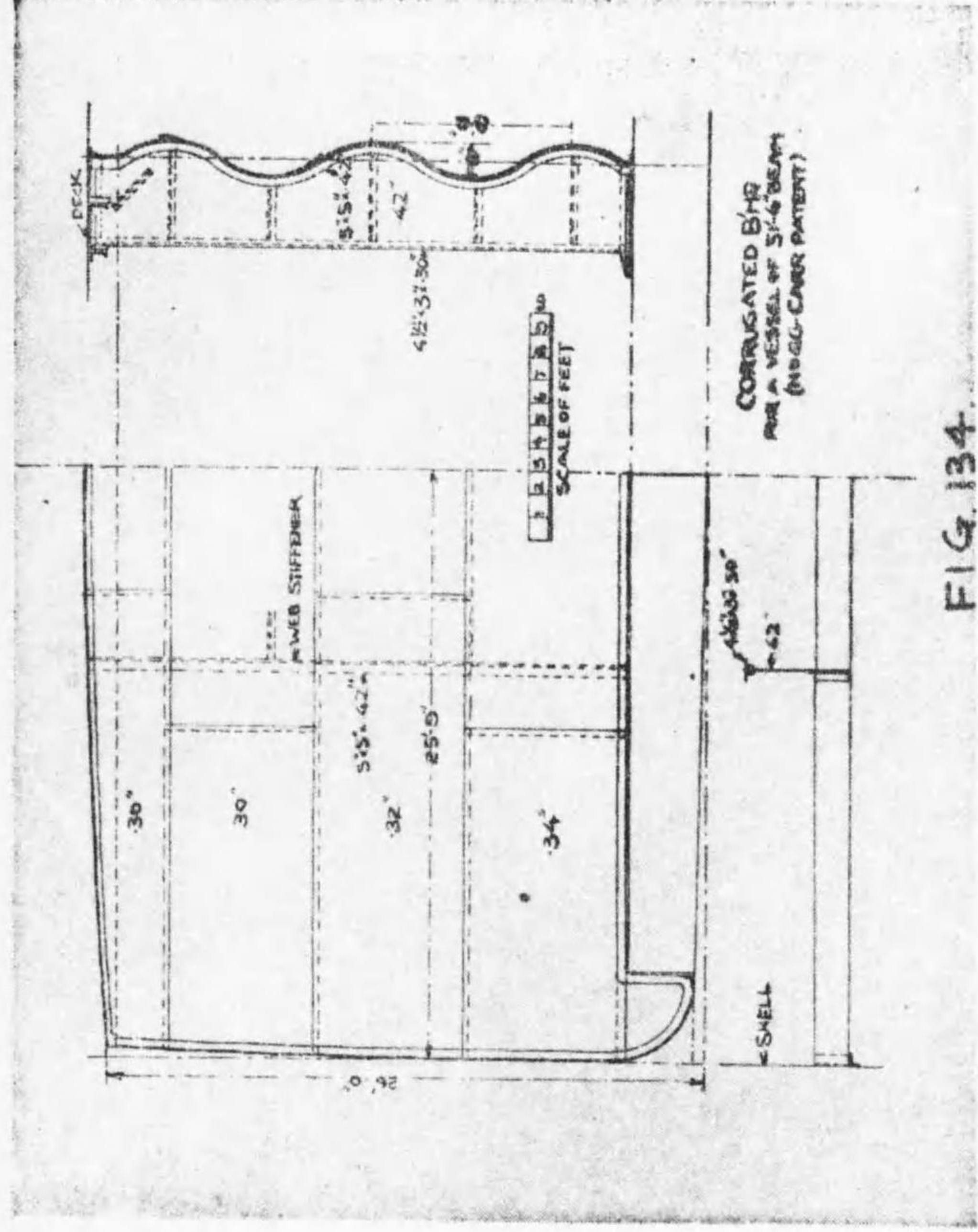
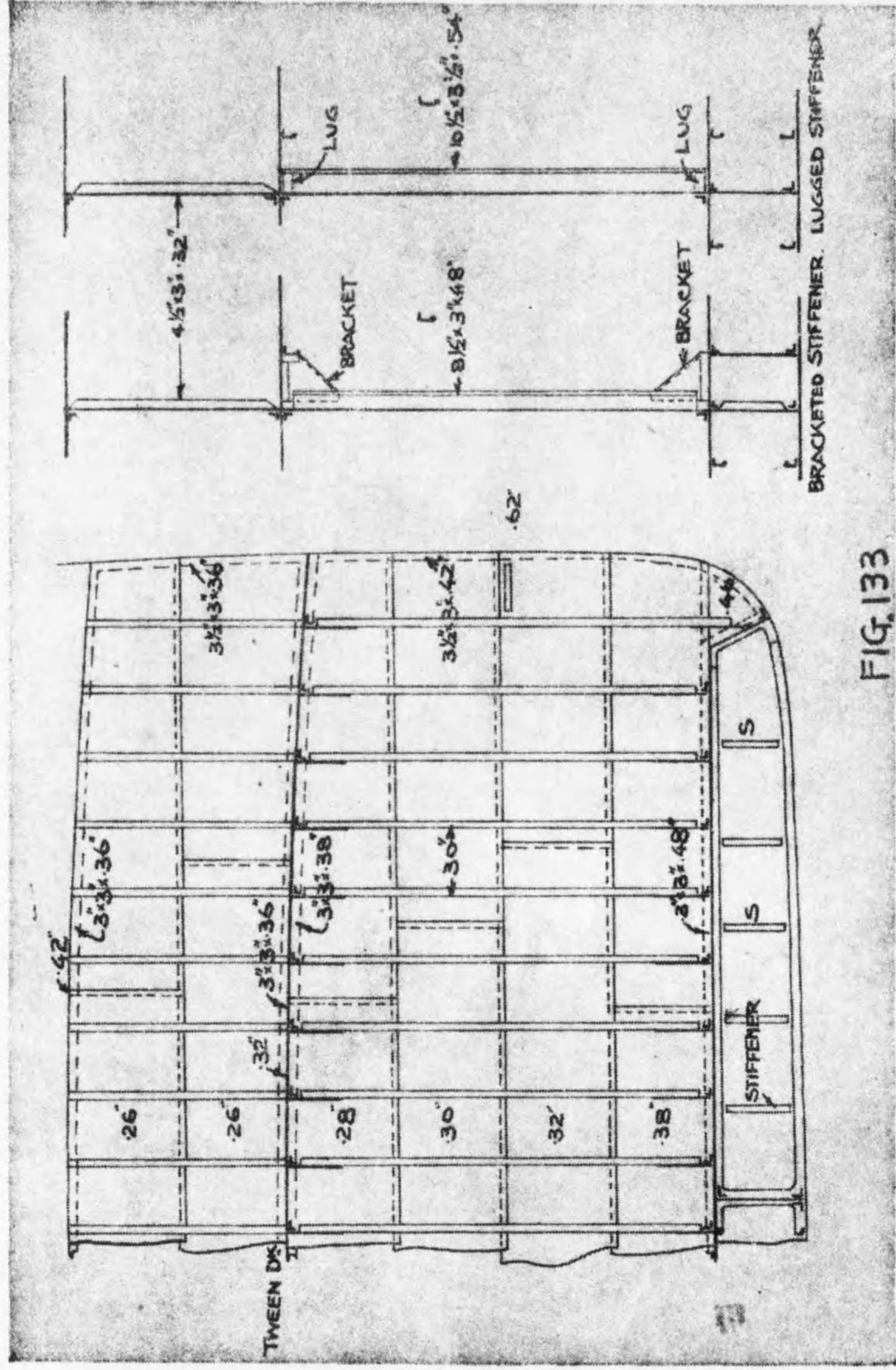
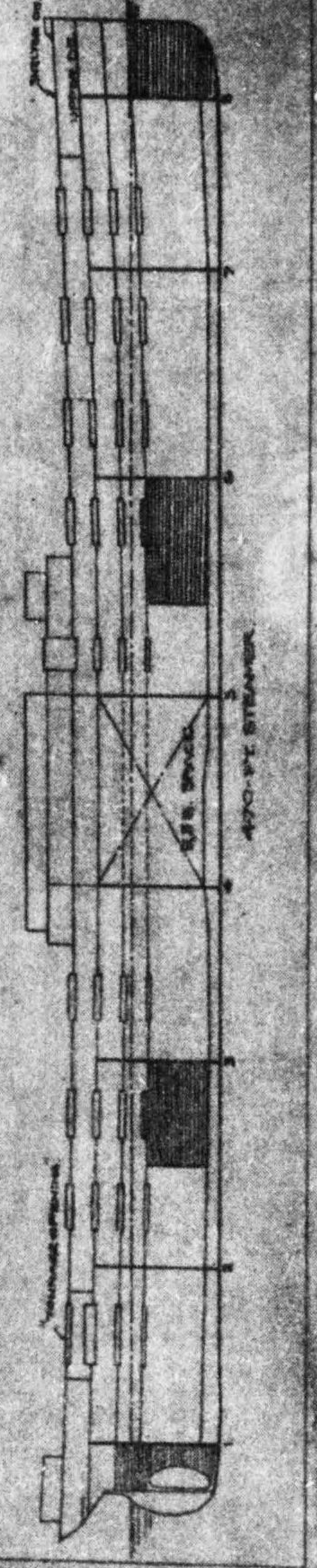
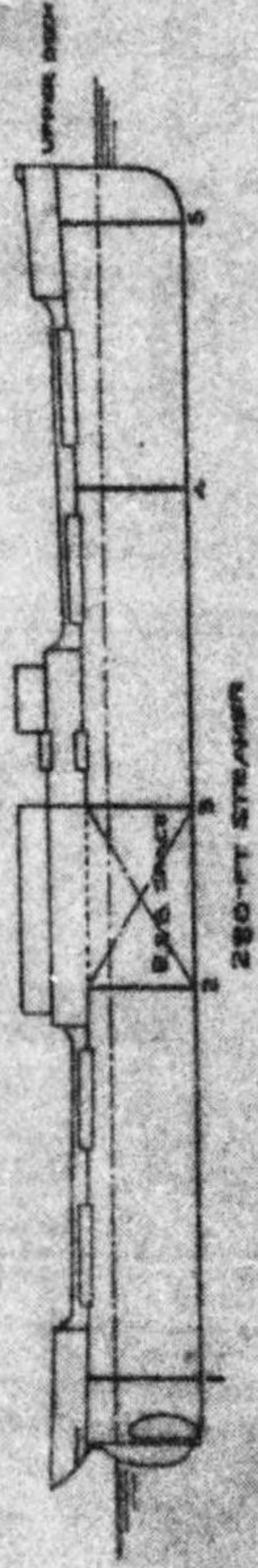
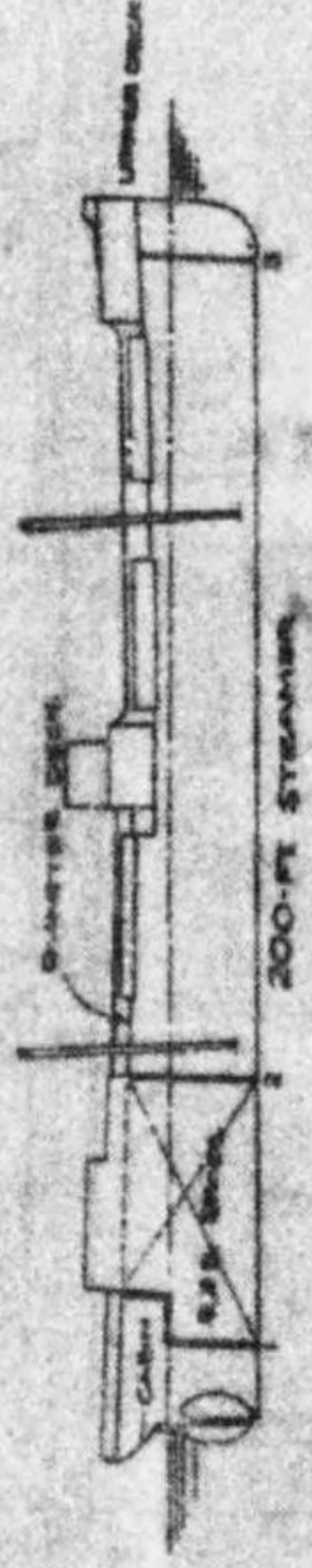
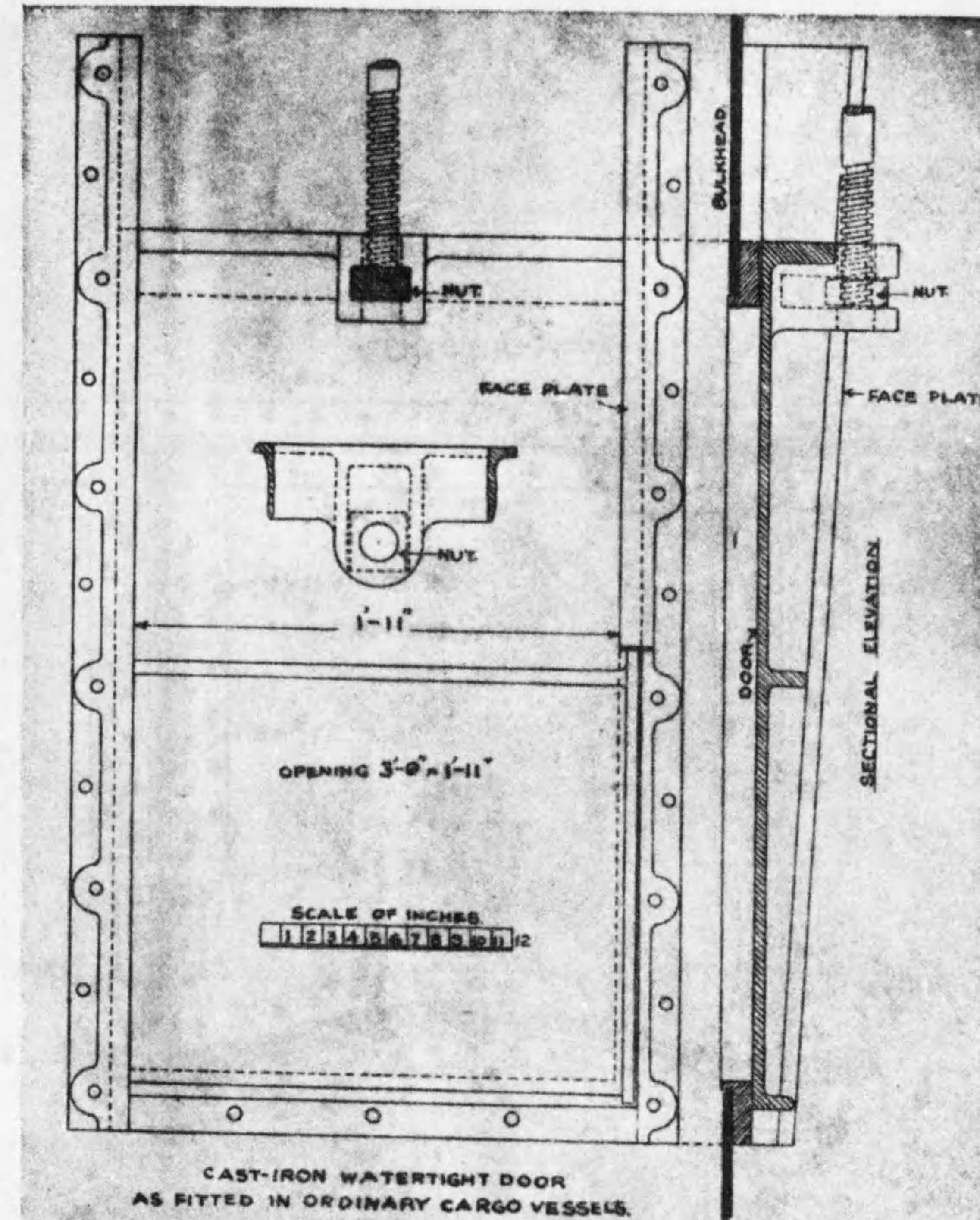

Fig. 135





CAST-IRON WATERTIGHT DOOR
AS FITTED IN ORDINARY CARGO VESSELS.

FIG 136

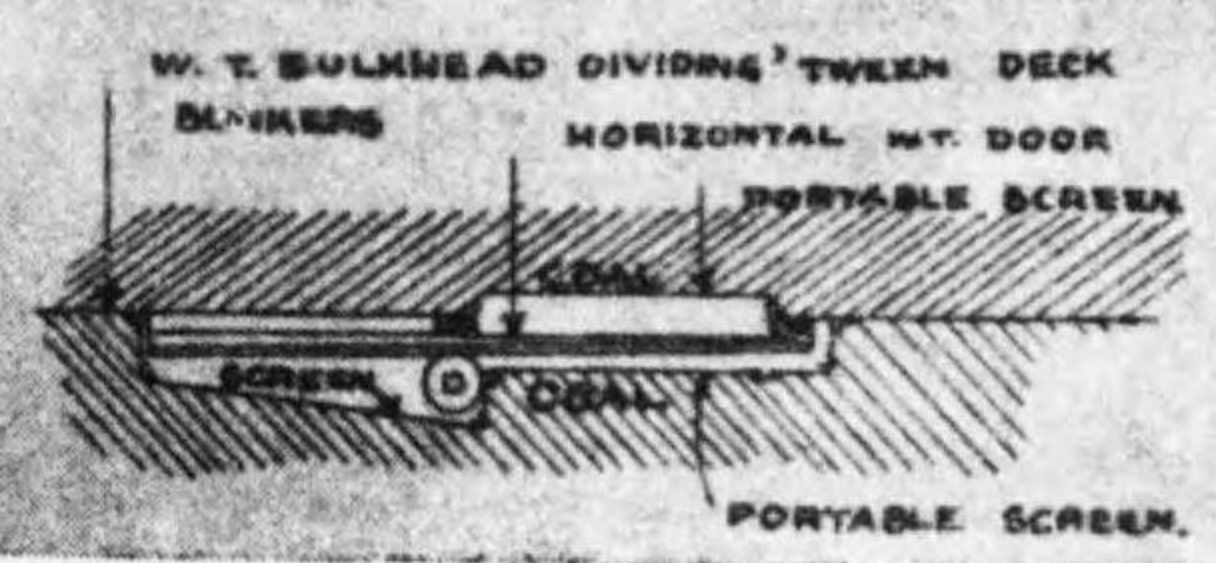

PORTABLE SCREEN.

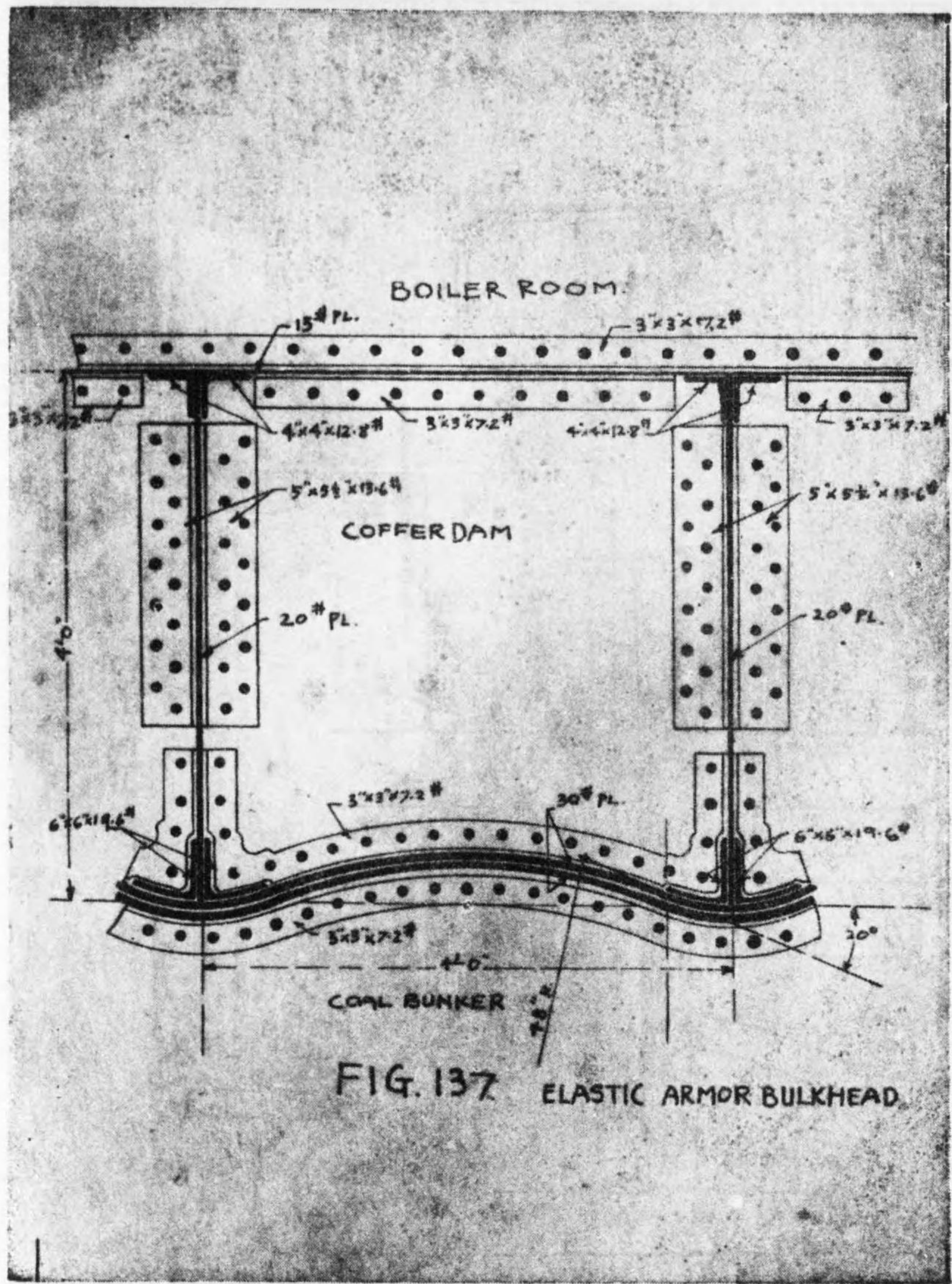
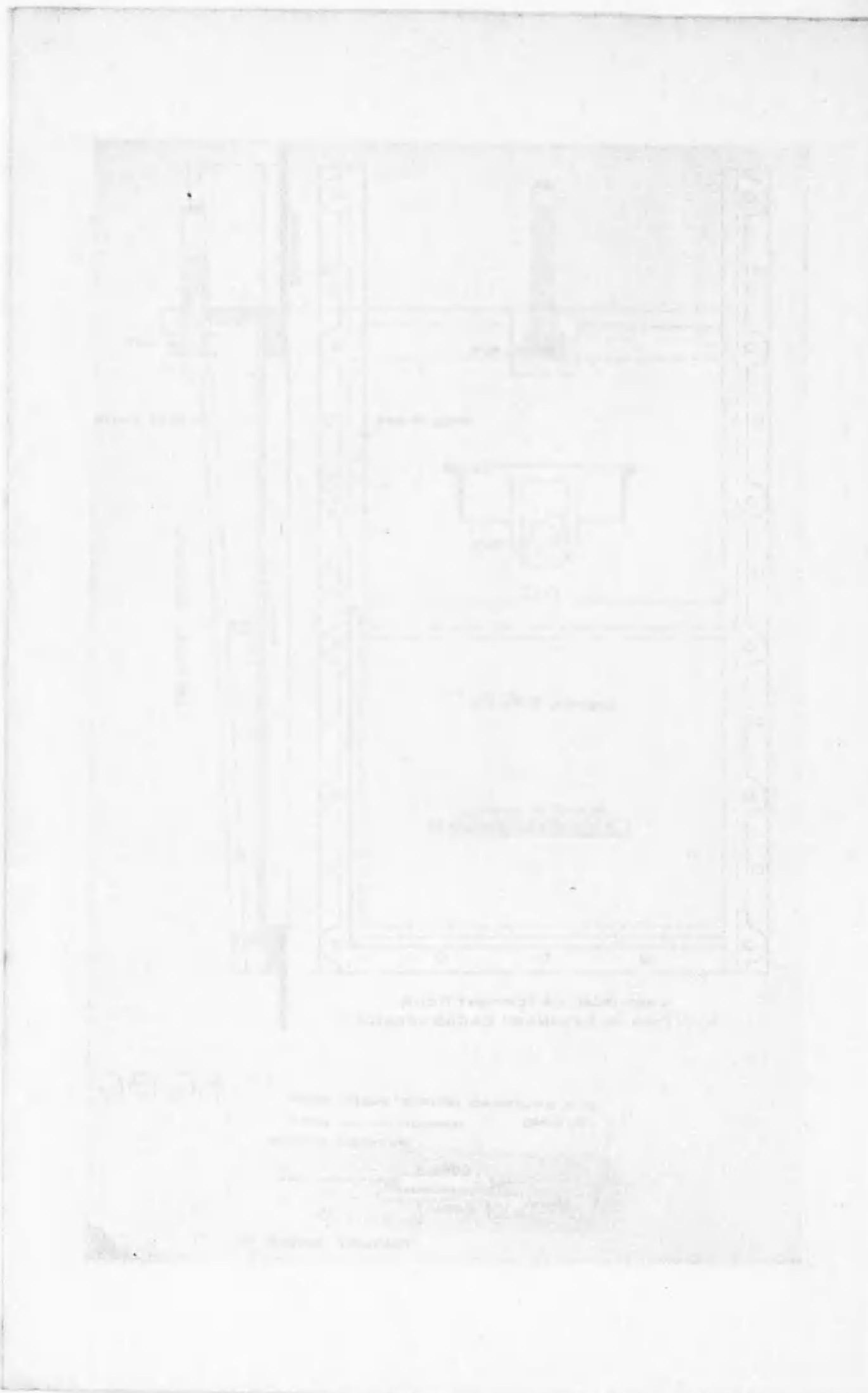

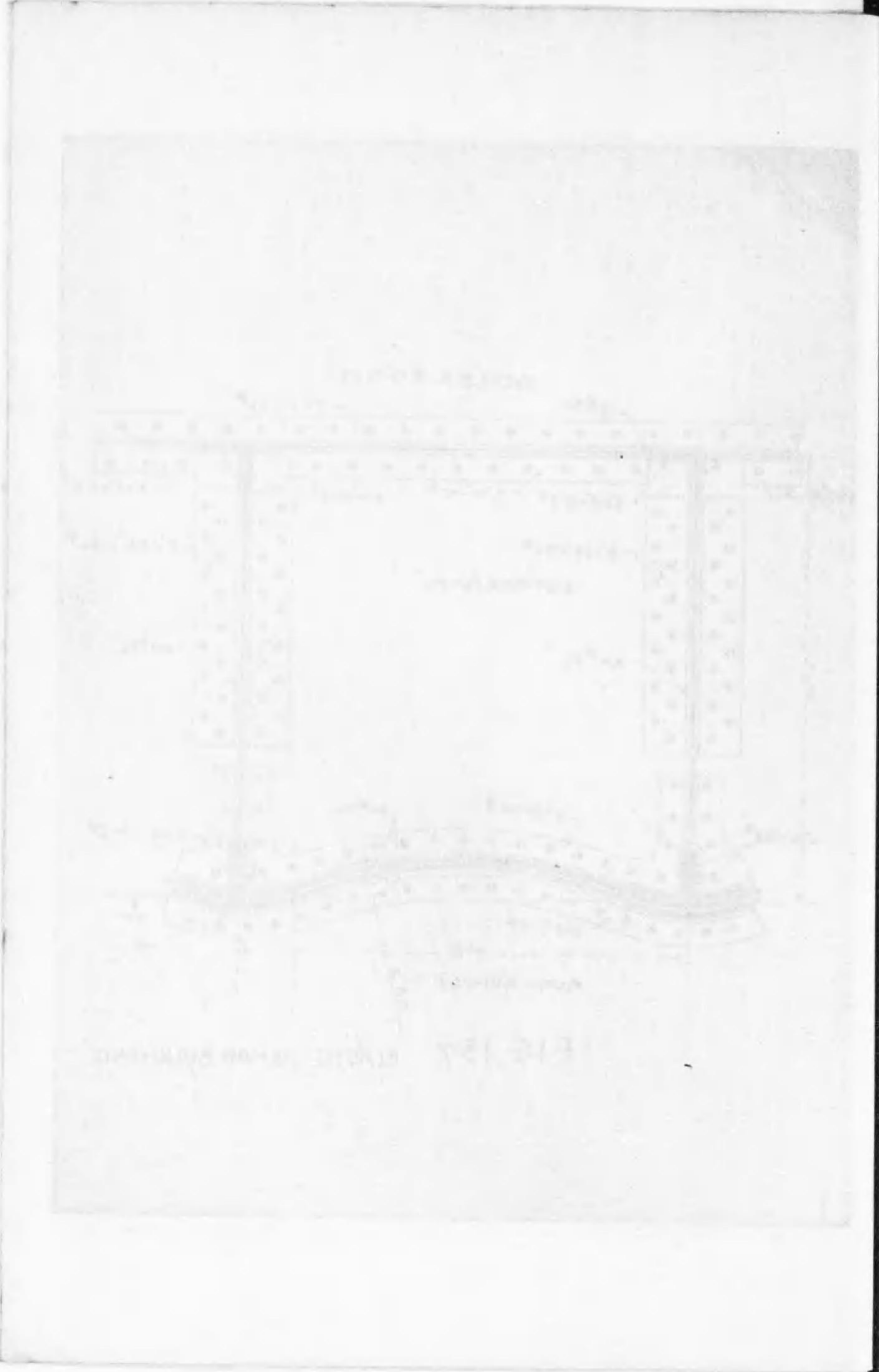

SECTION AT A-A, FIG.

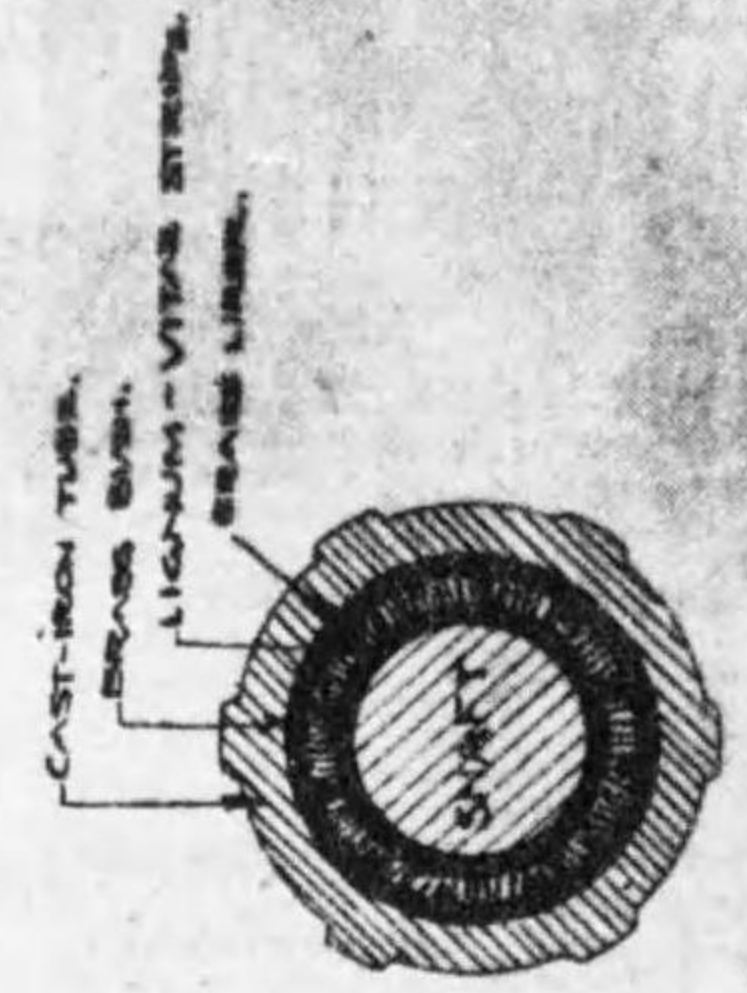
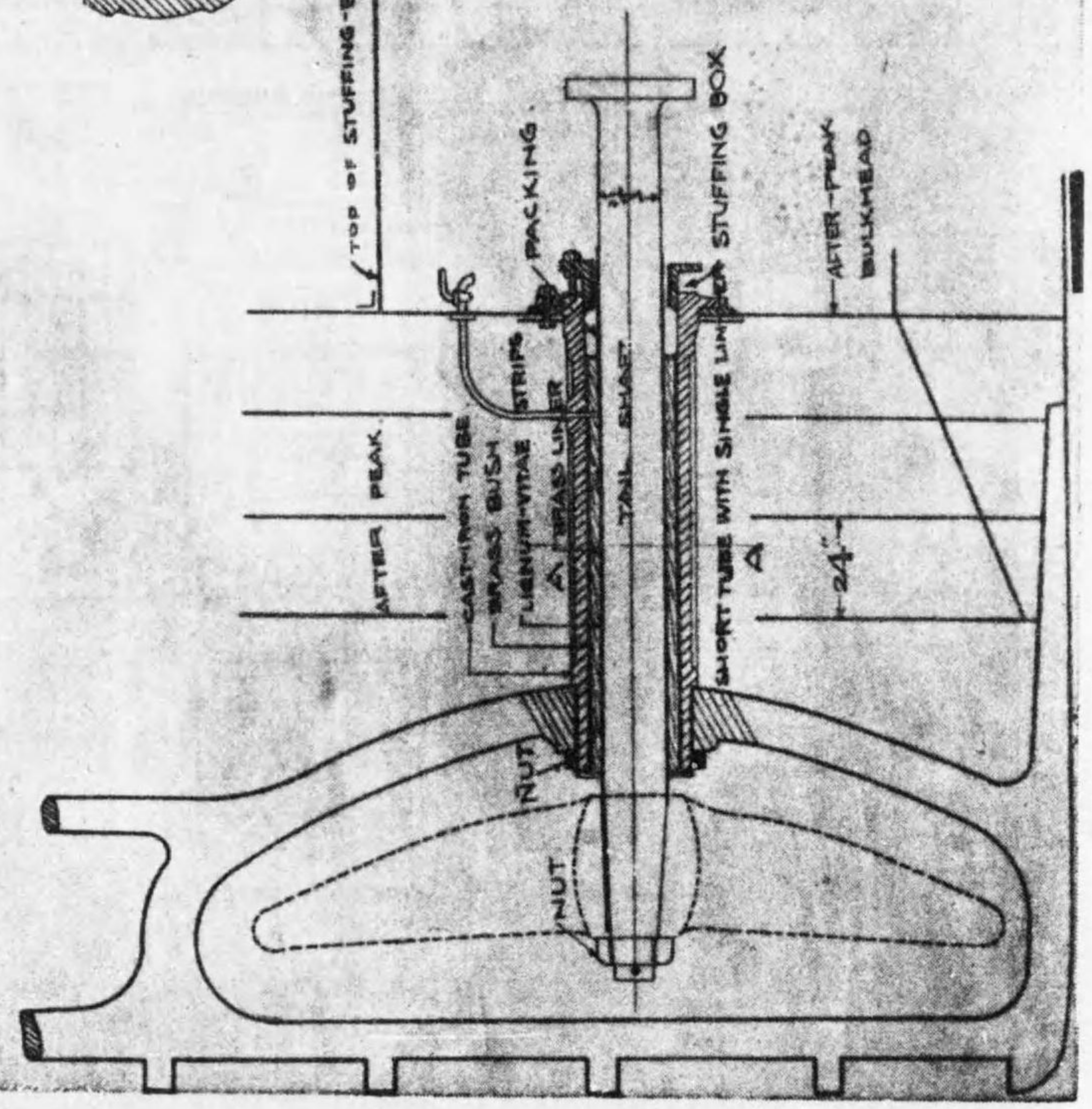

FIG. 138.



SECTION AT A-A, FIG.

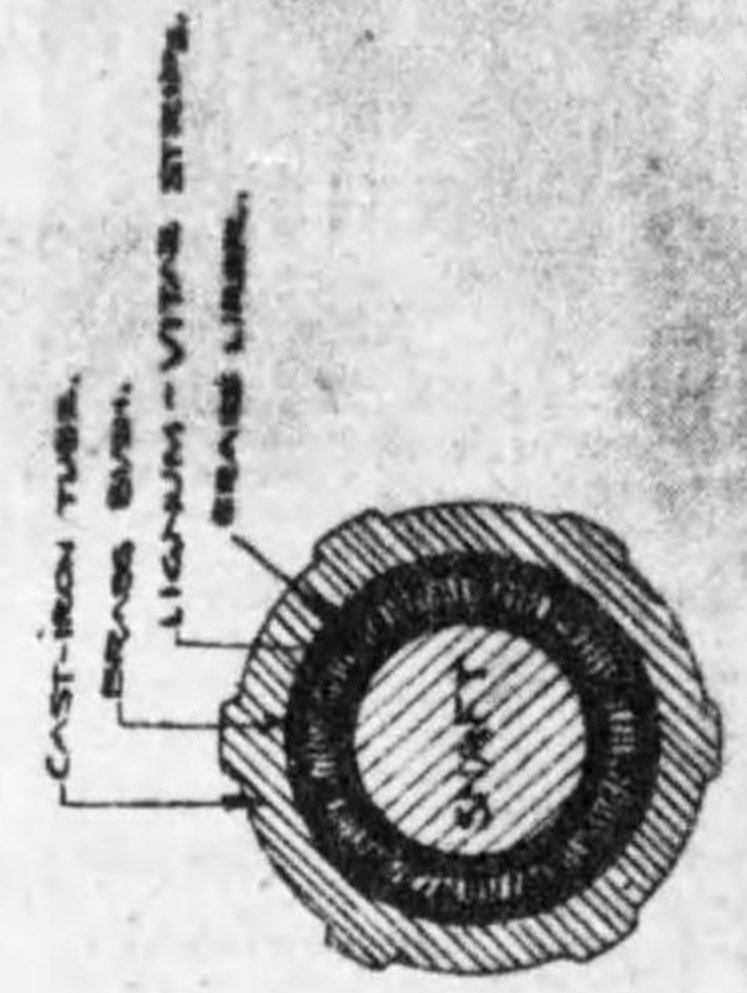
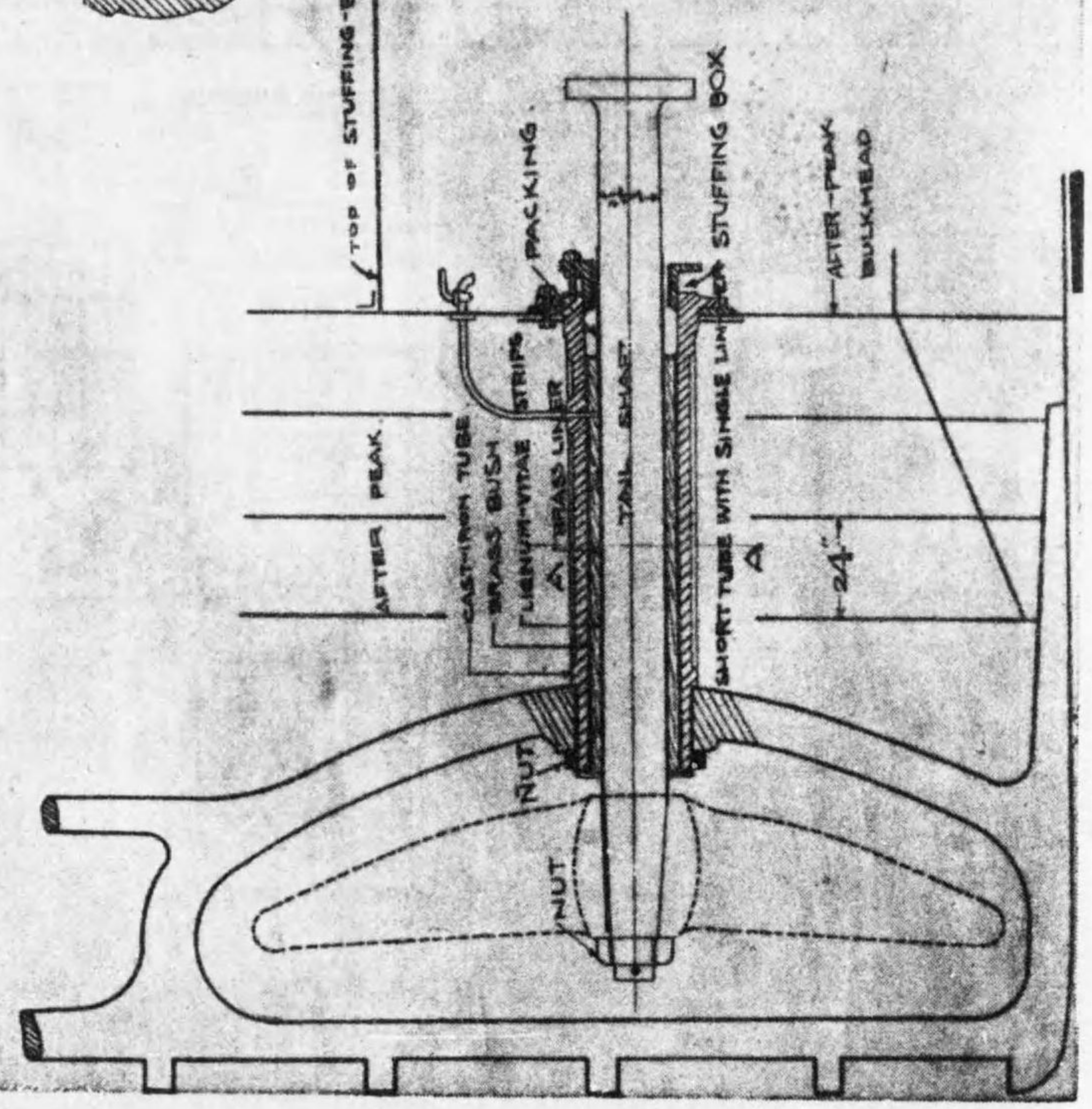
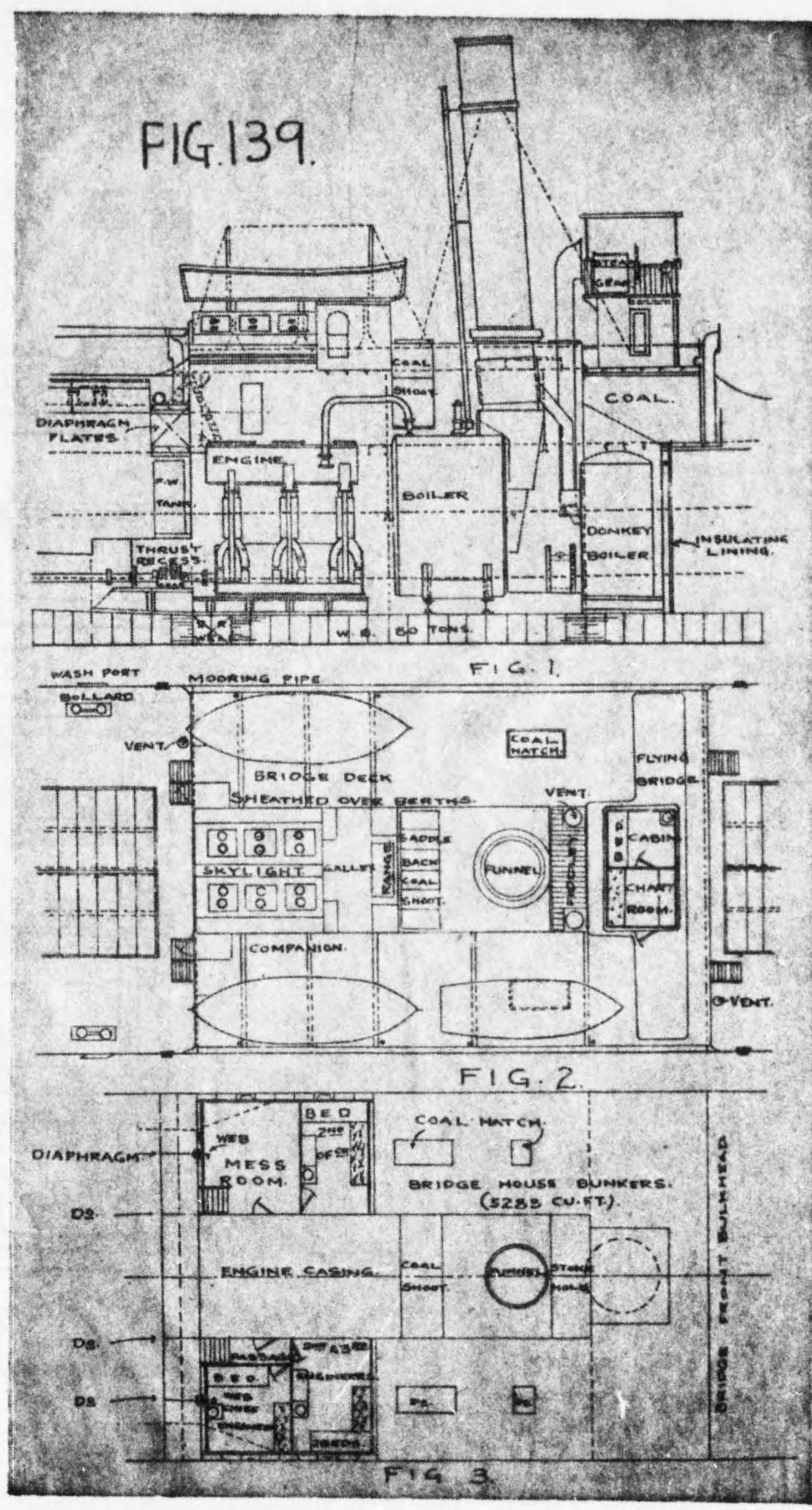
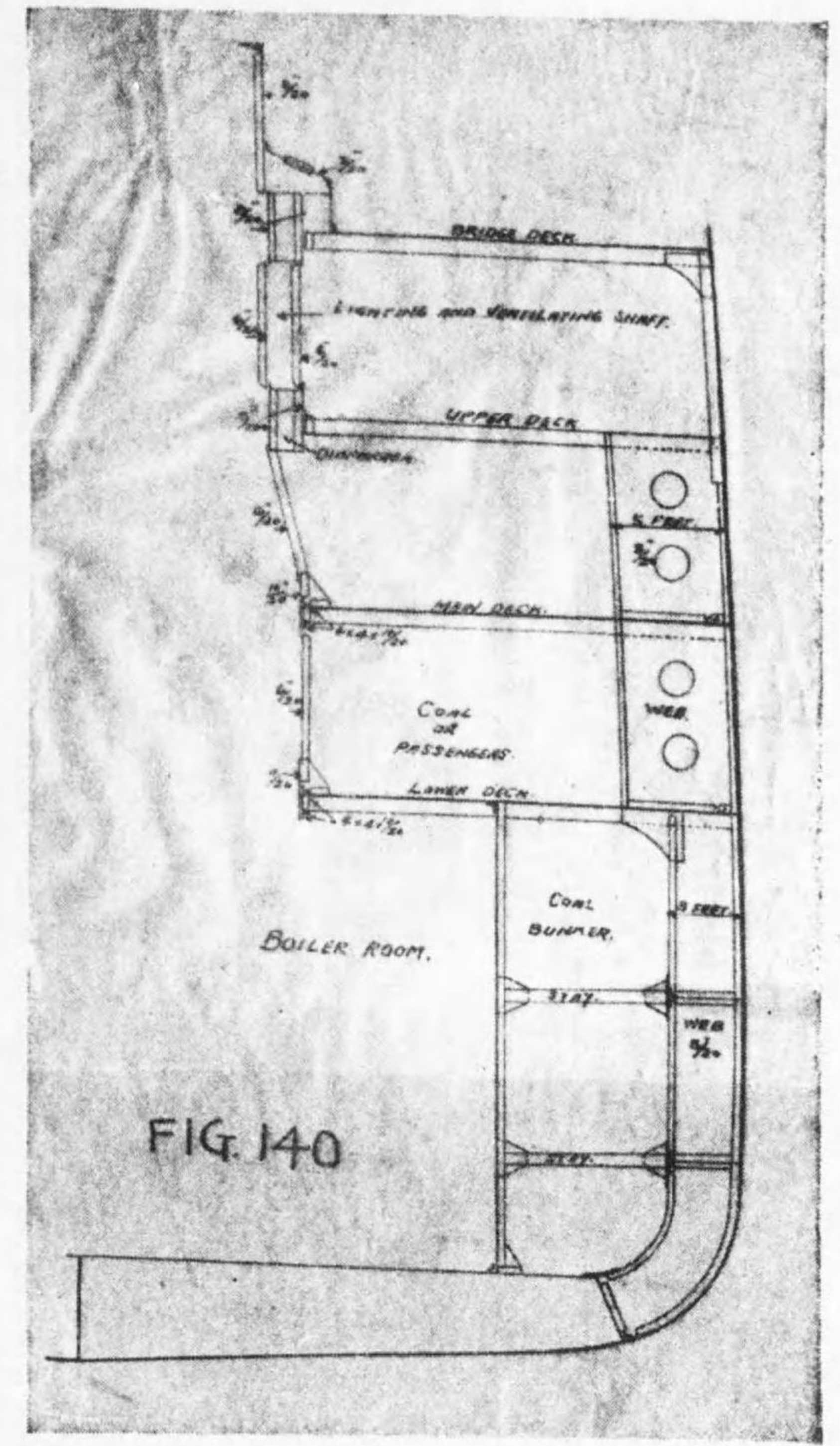
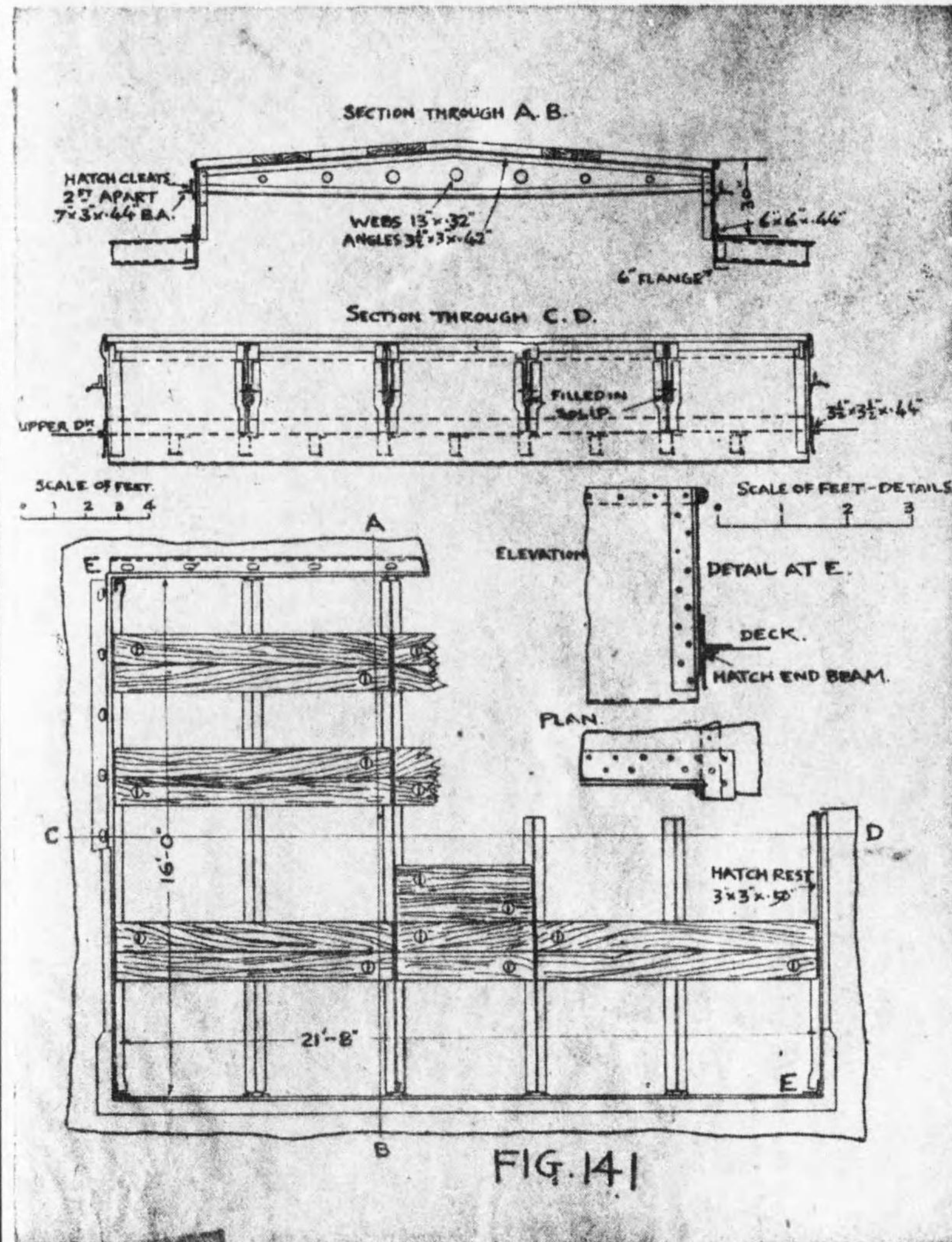

FIG. 138.







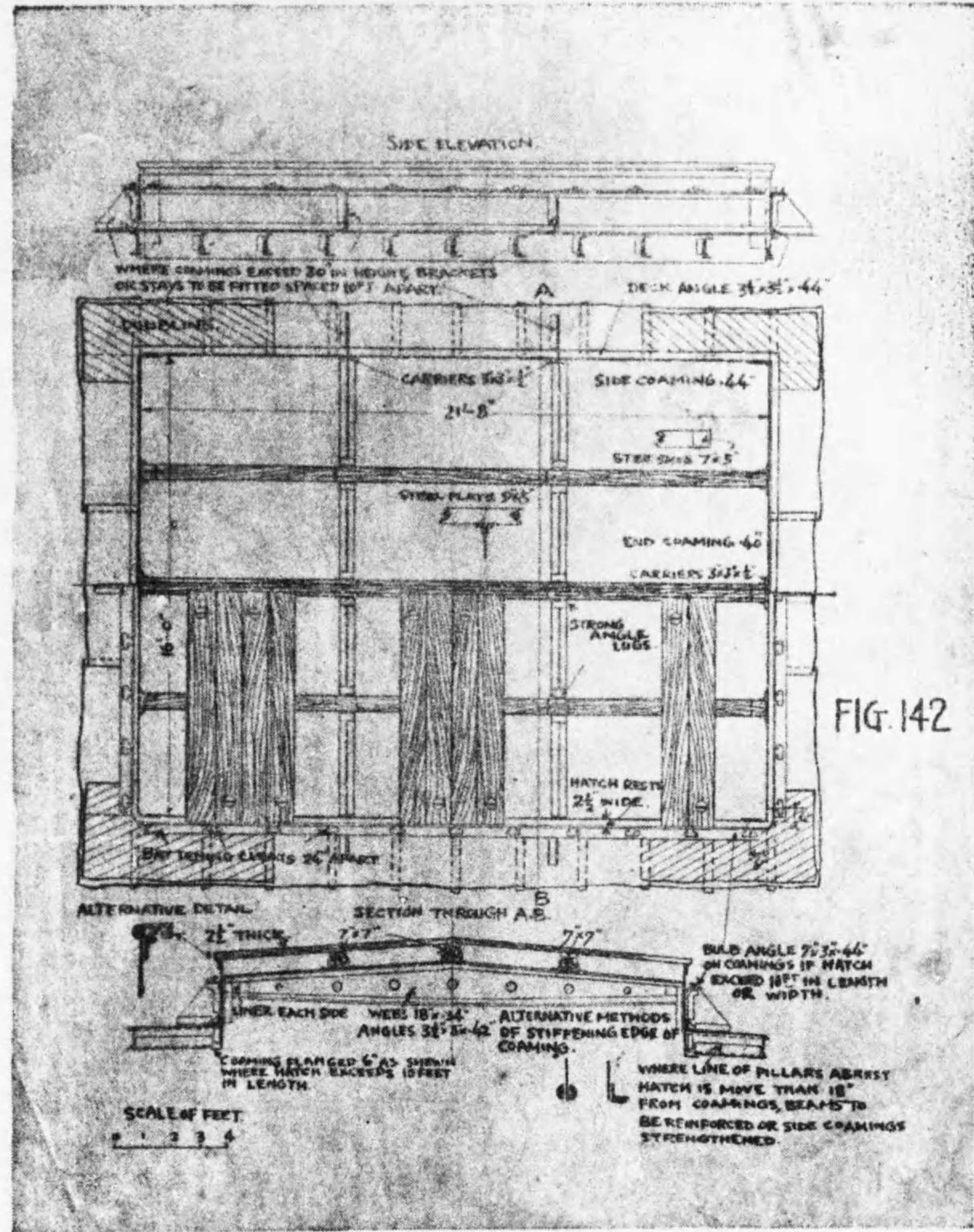

FIG 142

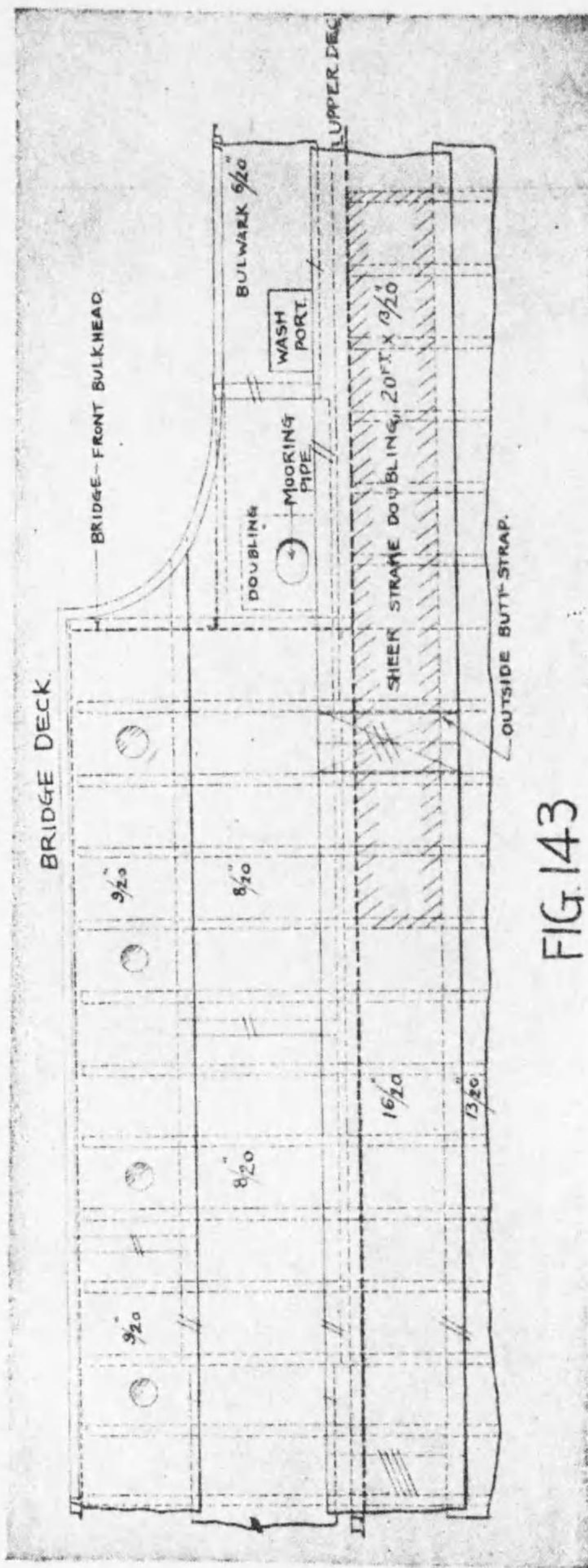

FIG. 143

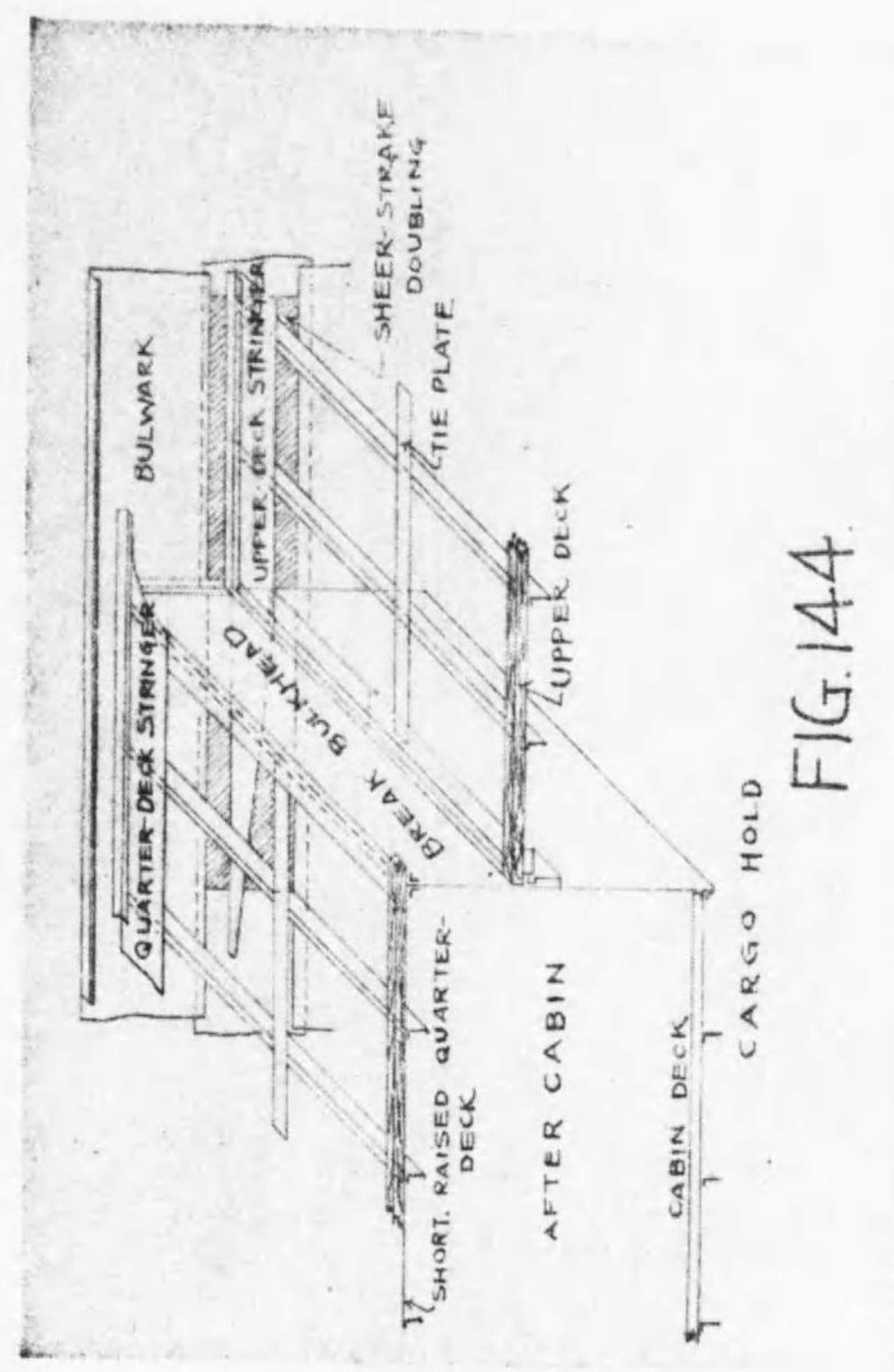

FIG. 144

FIG. 145

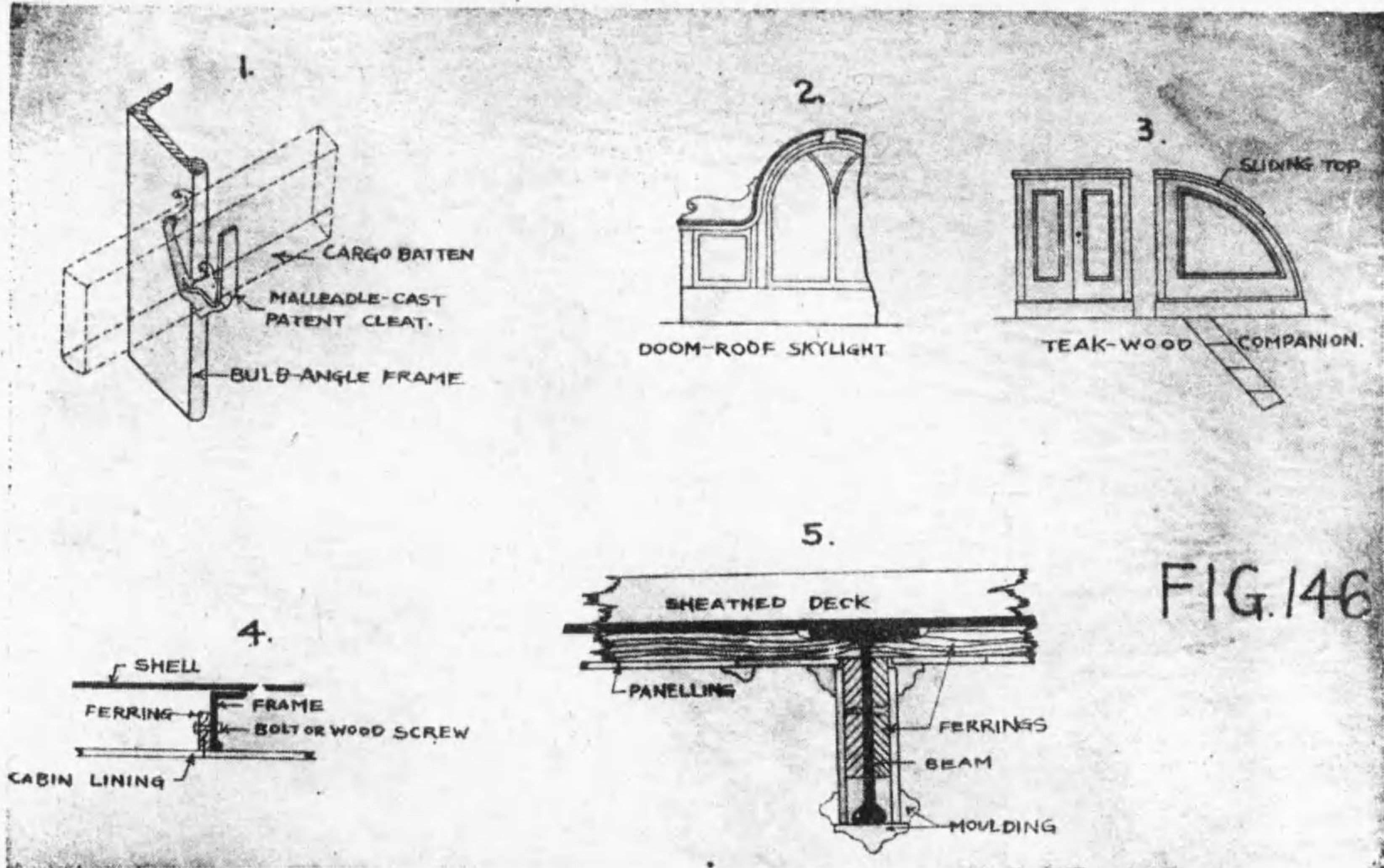
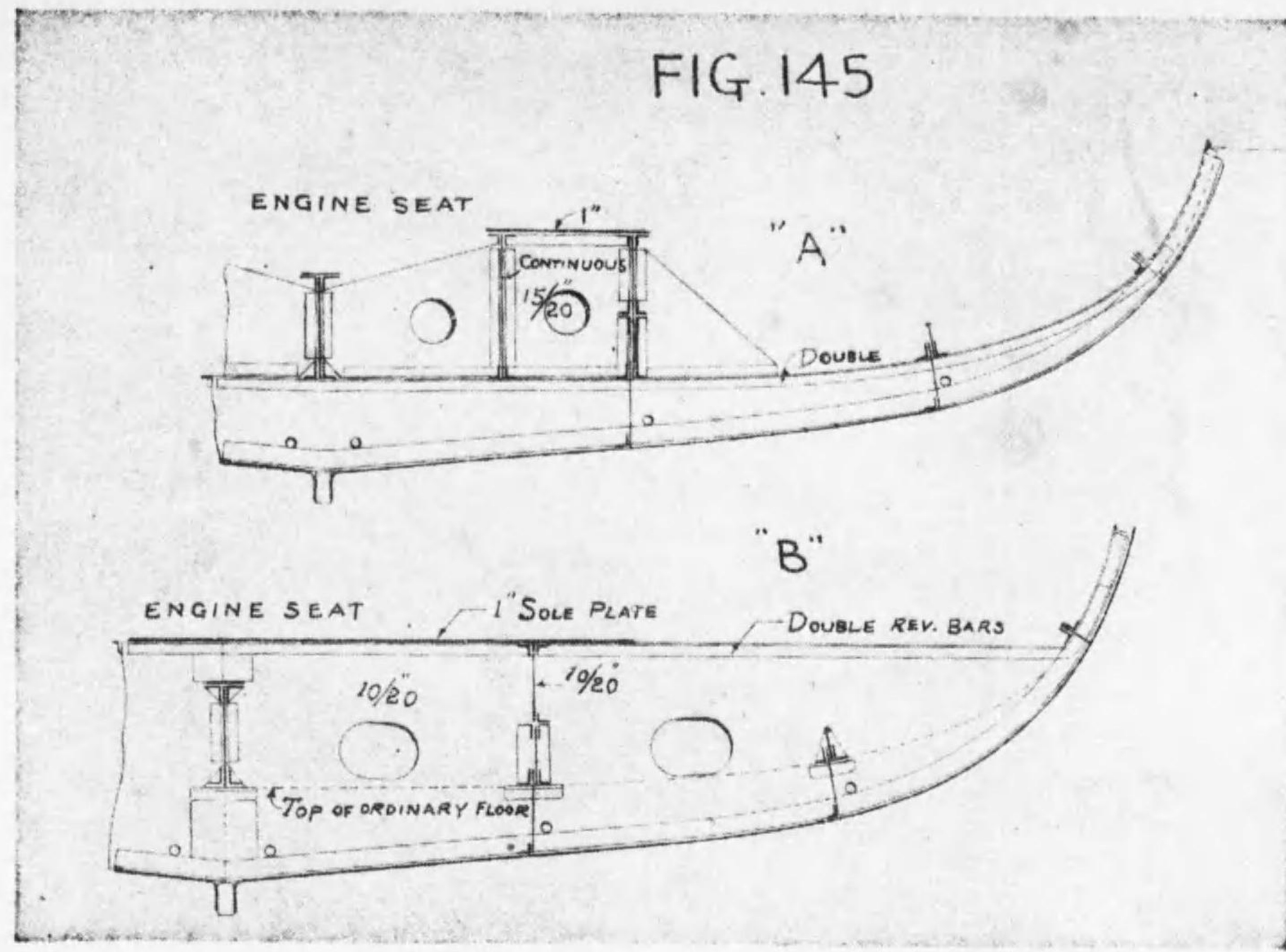

FIG. 146

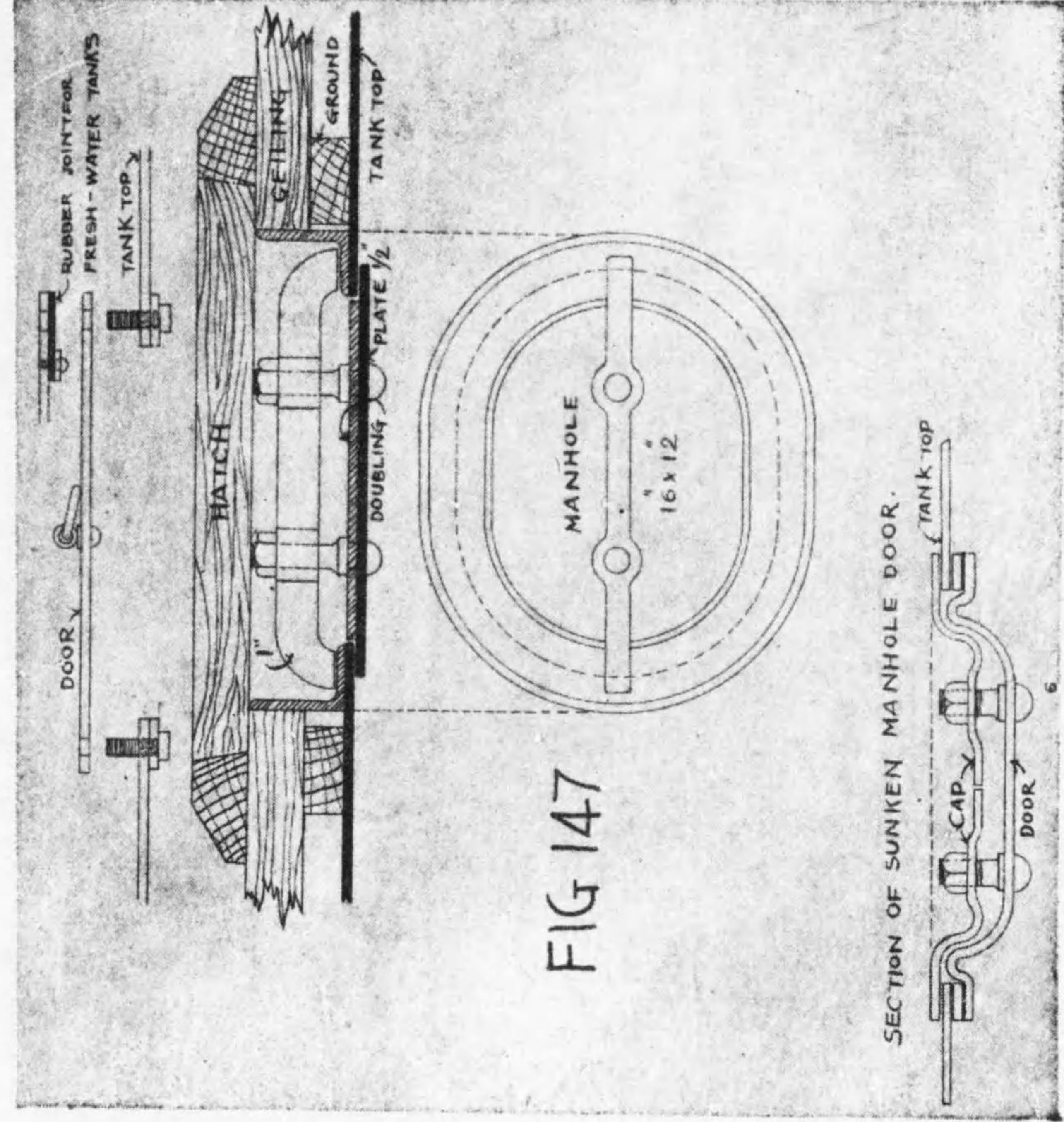

FIG 147

FIG 148-149

C C GIRDER

C C OF SHAFT

SECTION ENG 60

SECTION ENG 61

ENGINE SEAT
(FOR STEAM TURBINE)
SHOWING THE S. SIDE
SCALE 3/8" TO ONE FT.

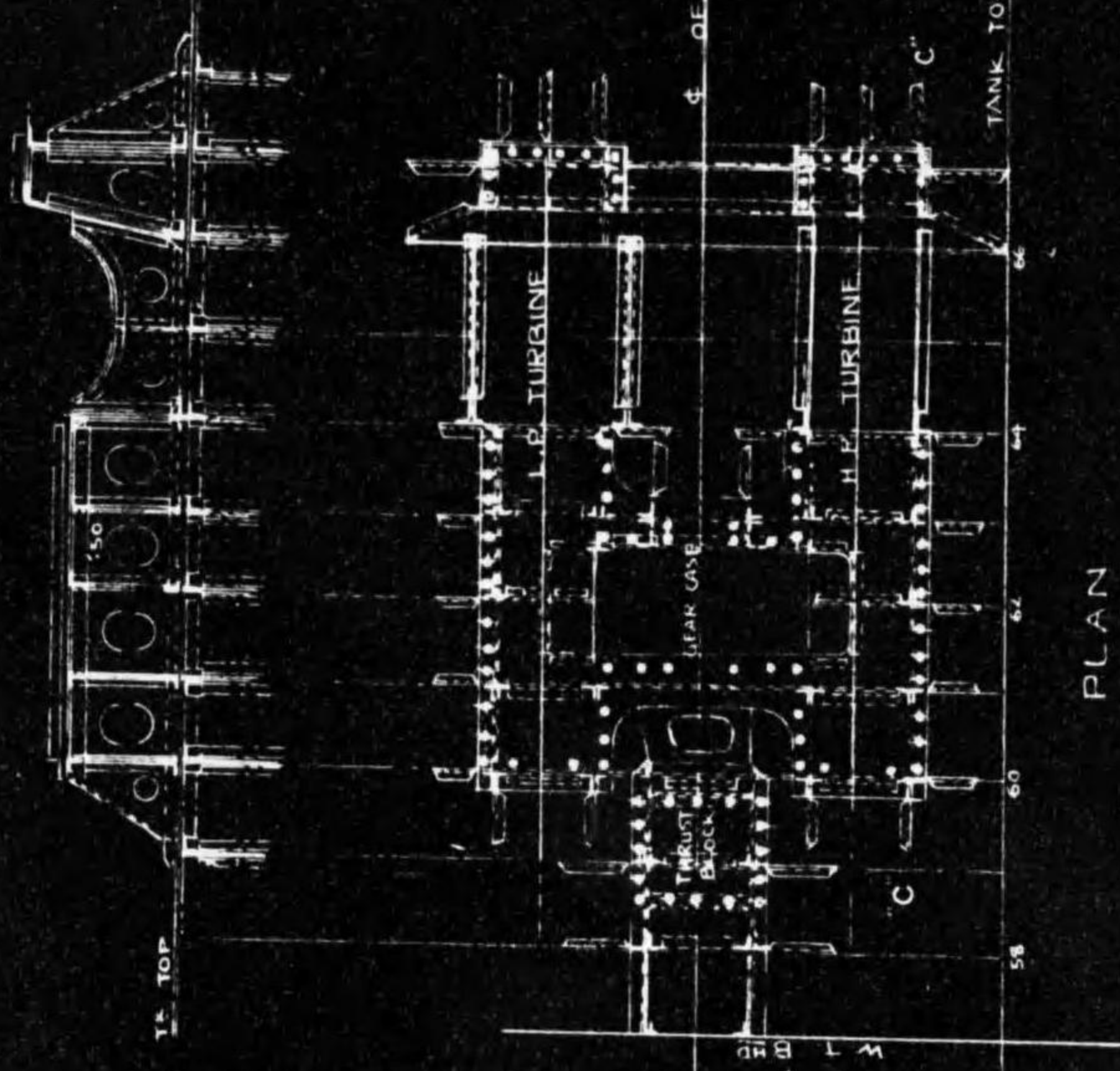

PLAN

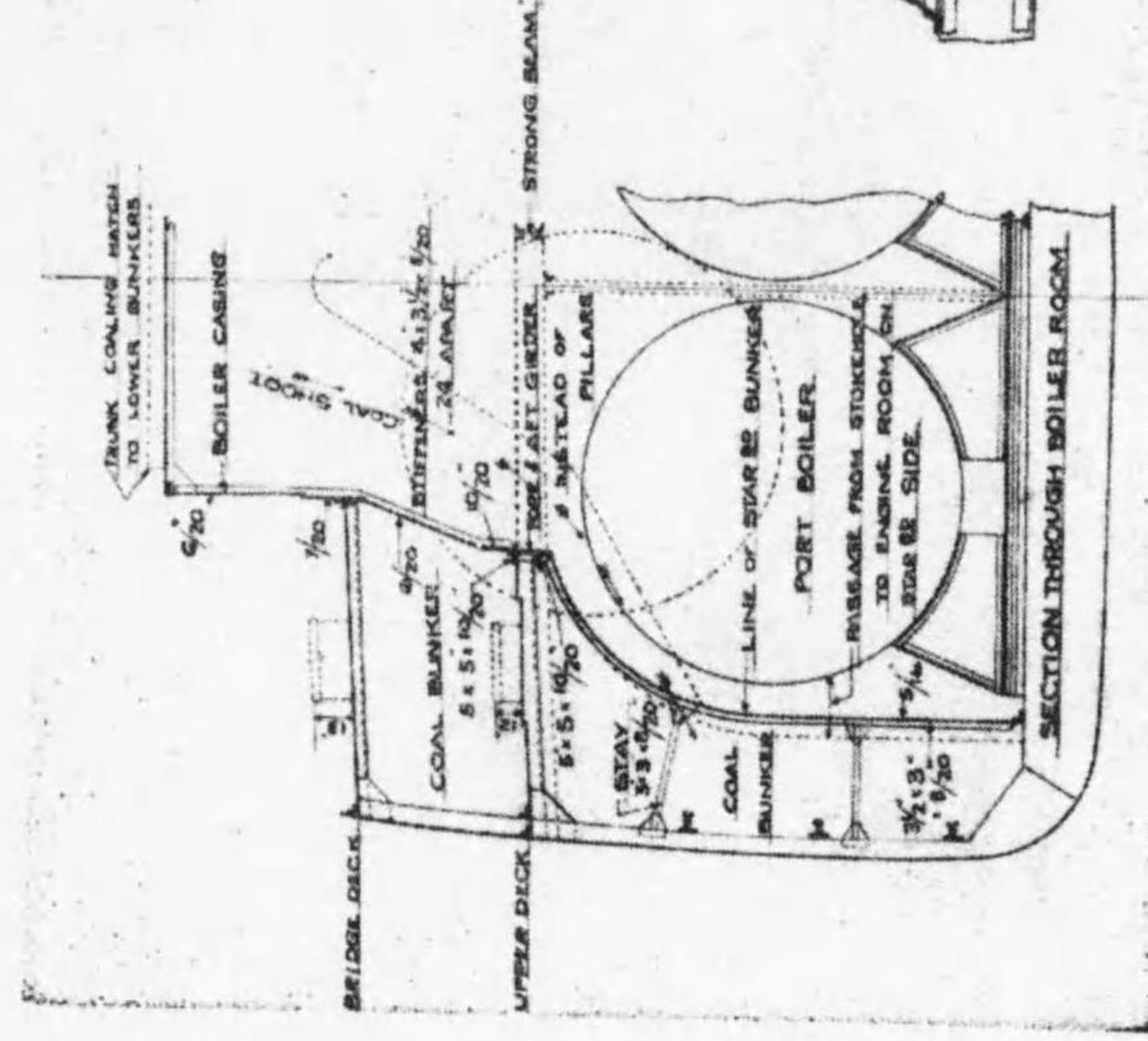

BOILER STOOL

FIG. 150

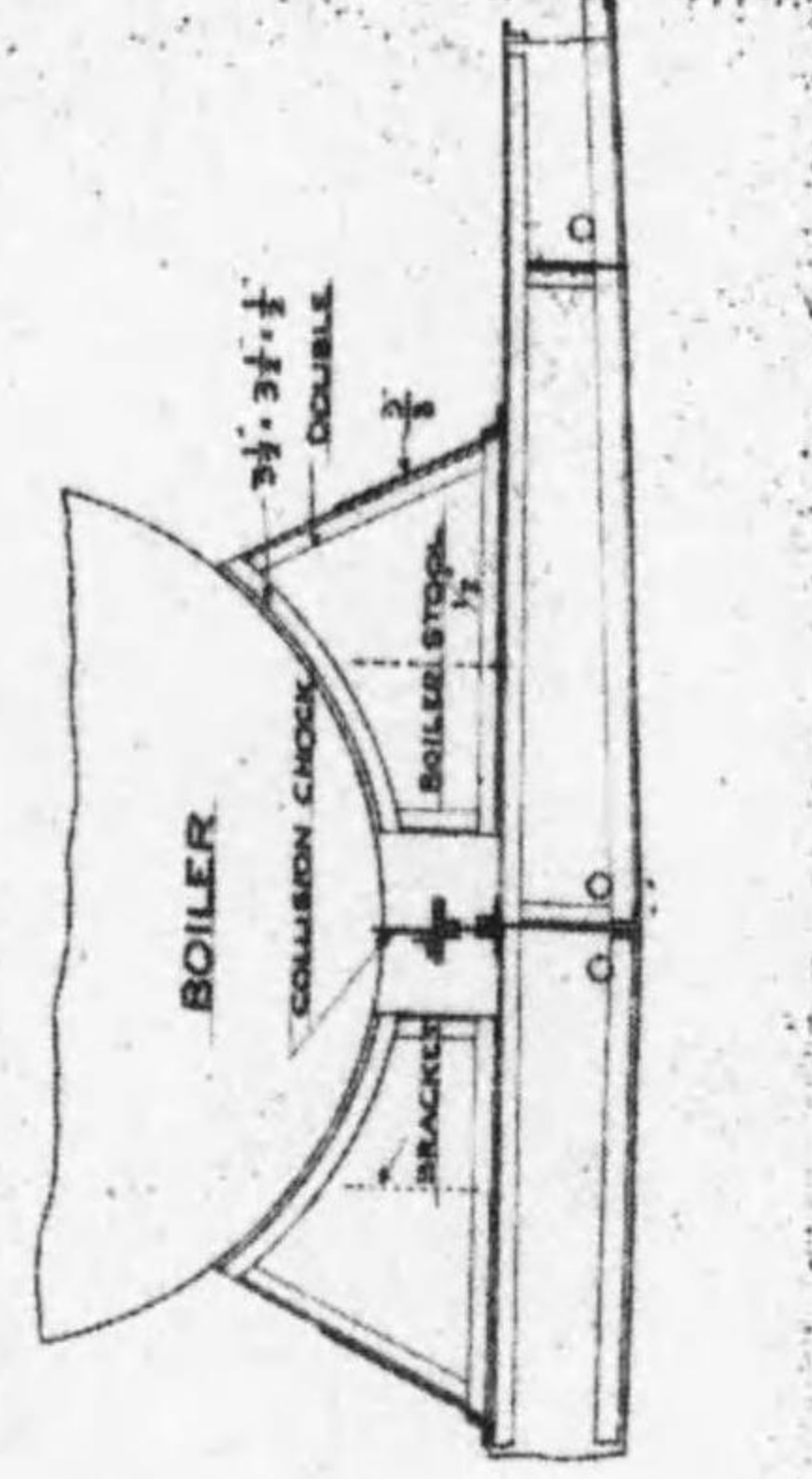

FIG 151
BOILER STOOL

SCALE 1/4" TO ONE FT.

RIVETING NOTE :

BOILER SEAT ANGLE (TANK TOP (11' 50) 10' 1/2" G.D.
TANK TOP TO FLANGE SEAM 10' 1/2" HORIZONTAL FLANGE 10' 1/2" 11' 50"

MAX. PITCH

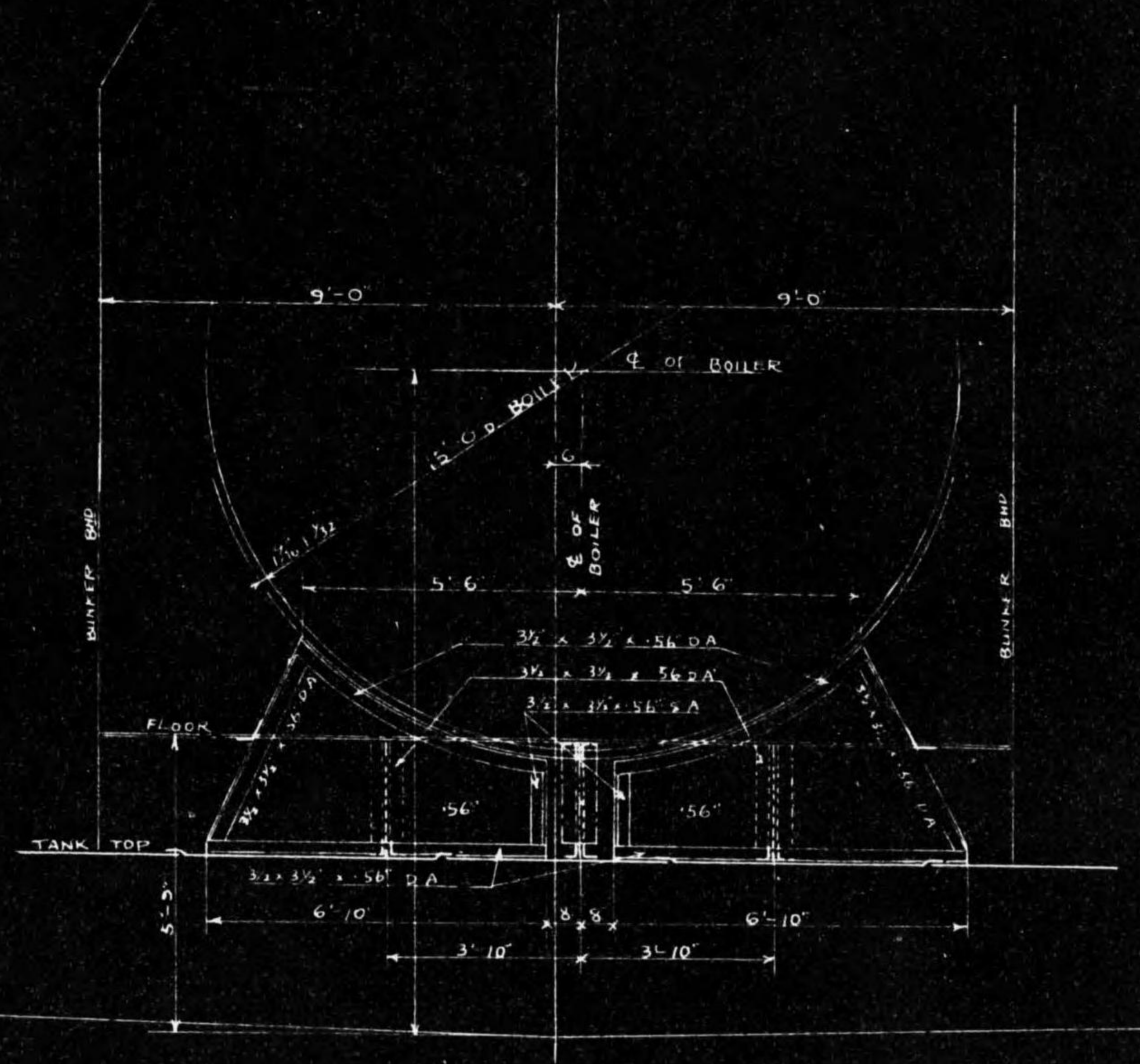
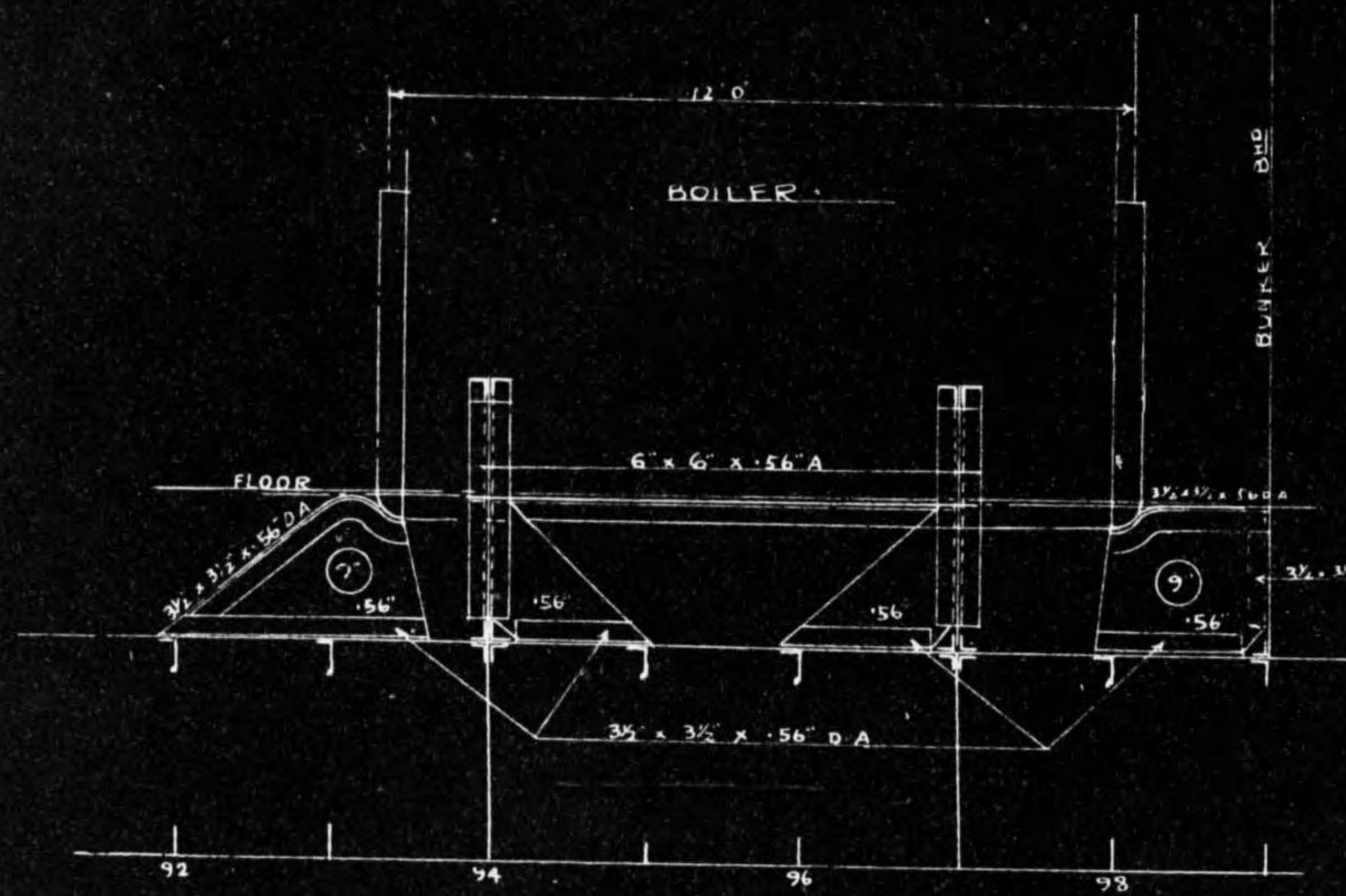

TRUNK DECK VESSEL.

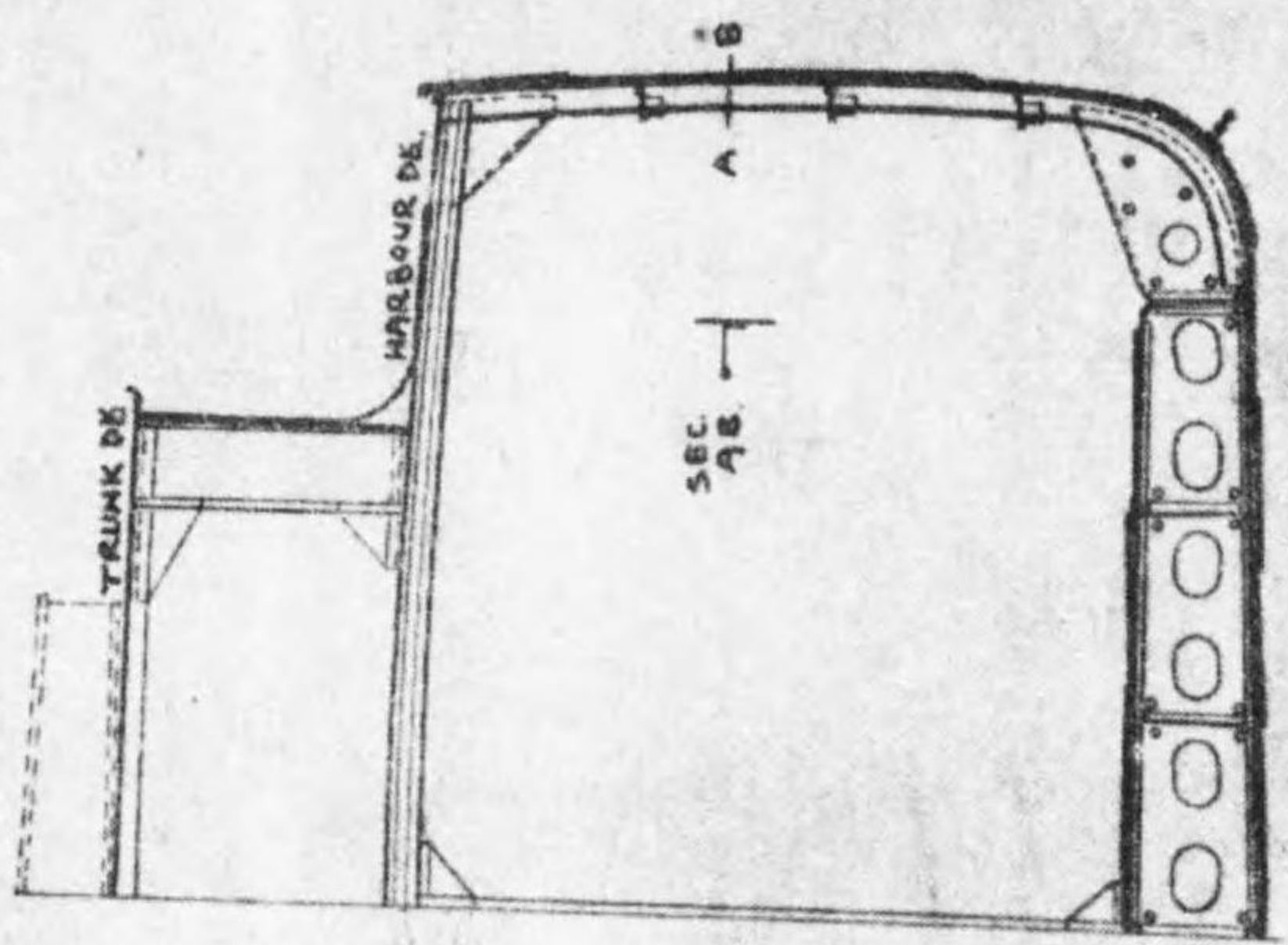

FIG. 153

CANTILEVER SHIP.

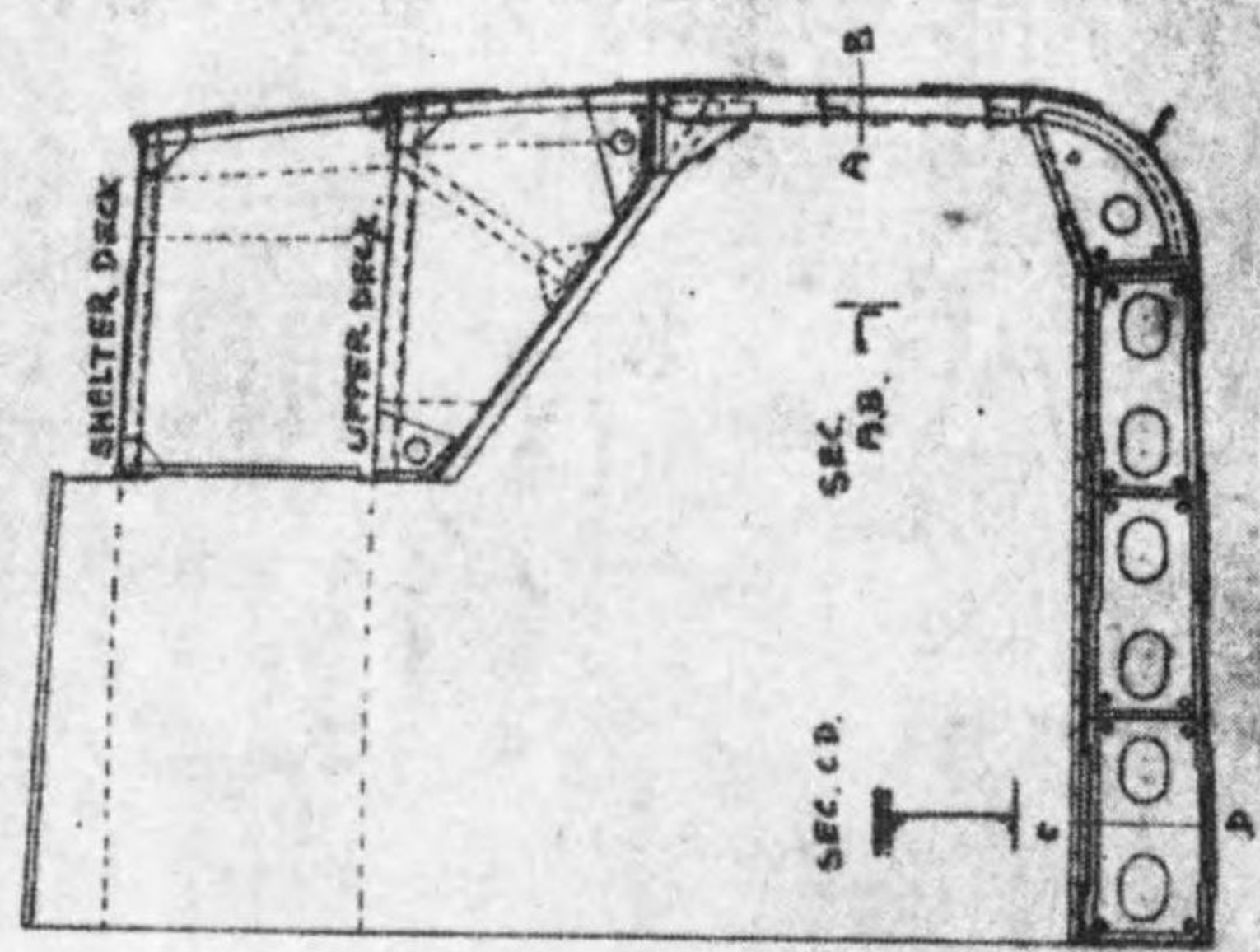

FIG. 154

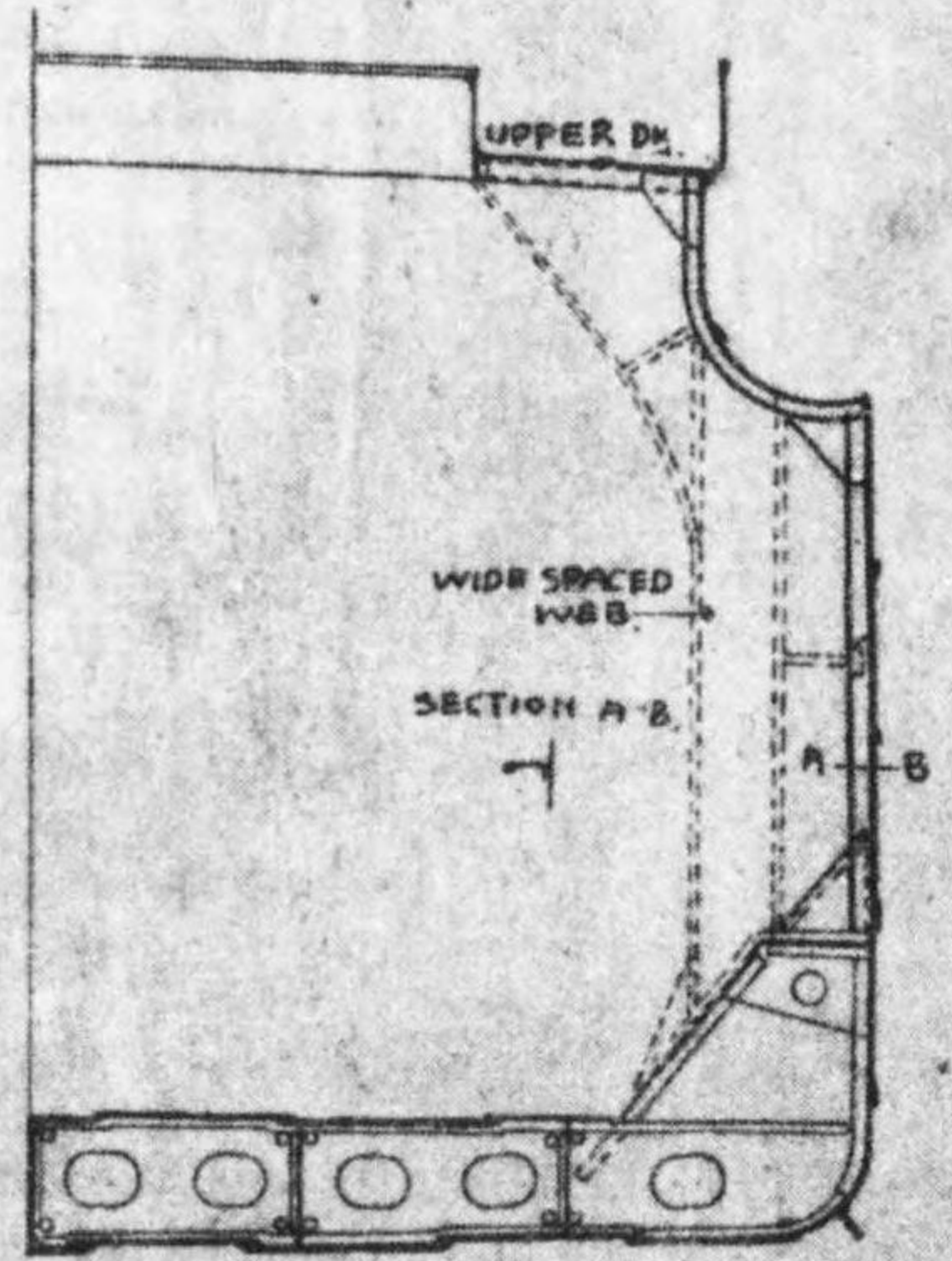

FIG. 155.

TURRET DECK VESSEL

SS. 350' 0" x 50' 0" x 26' 3" AND 33' 6".

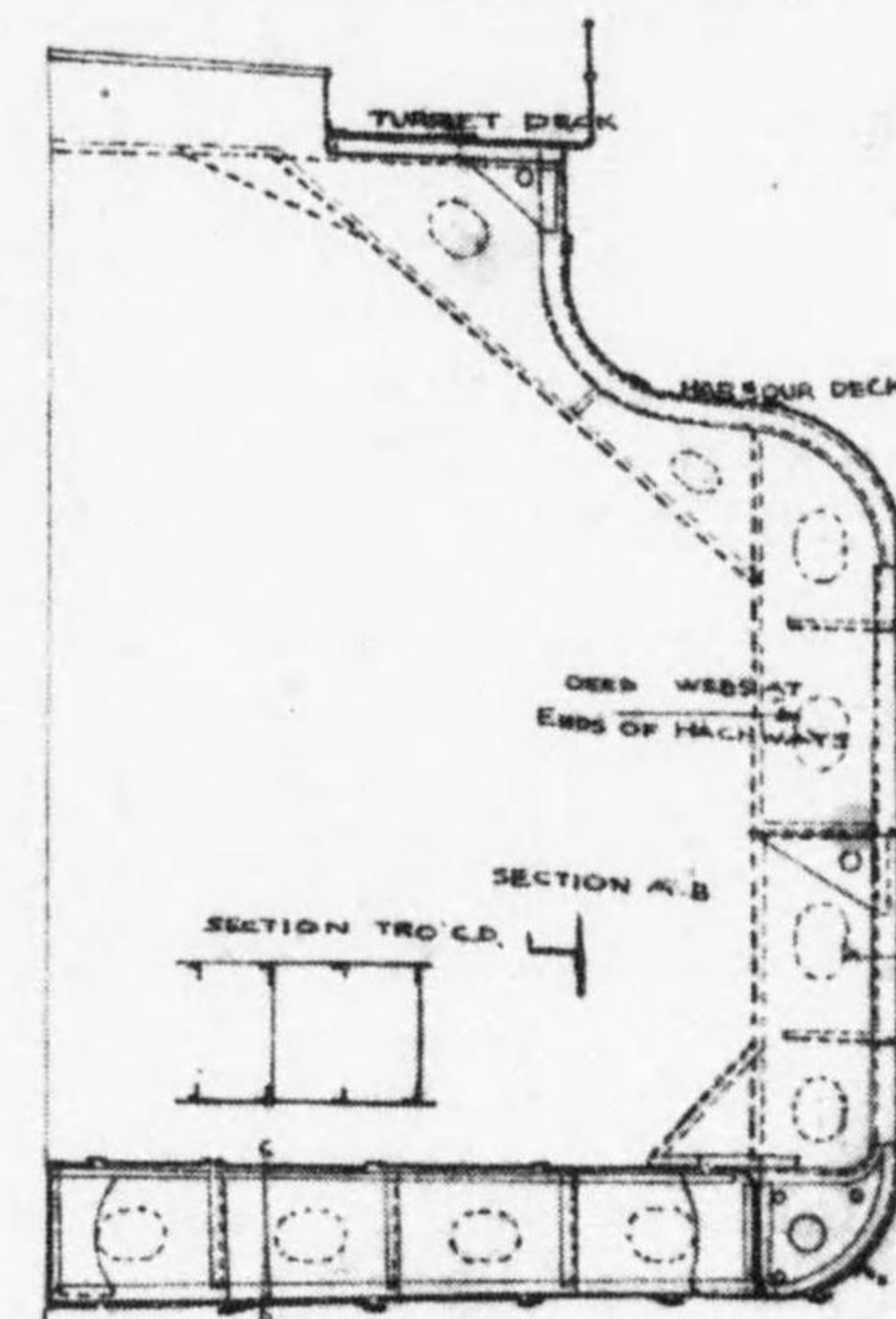
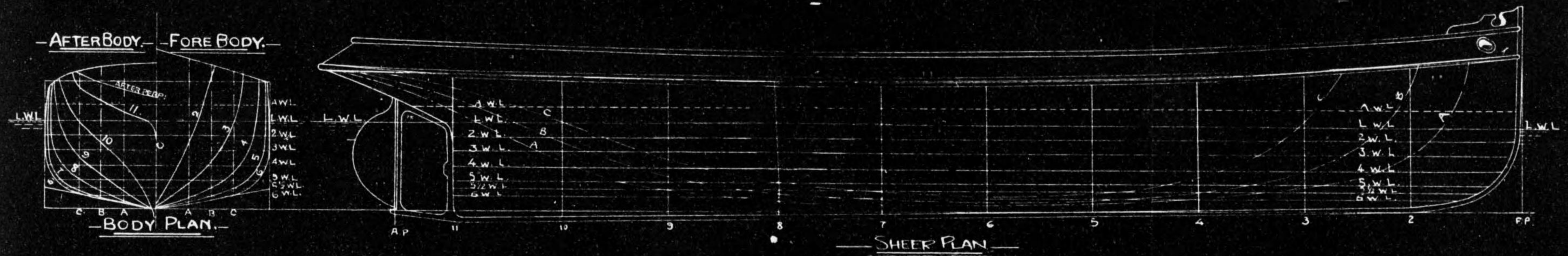

FIG 156

FIG. 157 a.

SHEER DRAWING OF A TUG

SCALE 1/8" = 1 FOOT



PRINCIPAL DIMENSIONS

	FT.	INS.
LENGTH BETWEEN PERPENDICULARS	74	0
BREADTH MOULDED	14	6
DEPTH MOULDED	8	3
DRAUGHT MOULDED FORWARD	5	1
D° AF	6	2
D° MEAN	5	9 1/2



FIG. 159

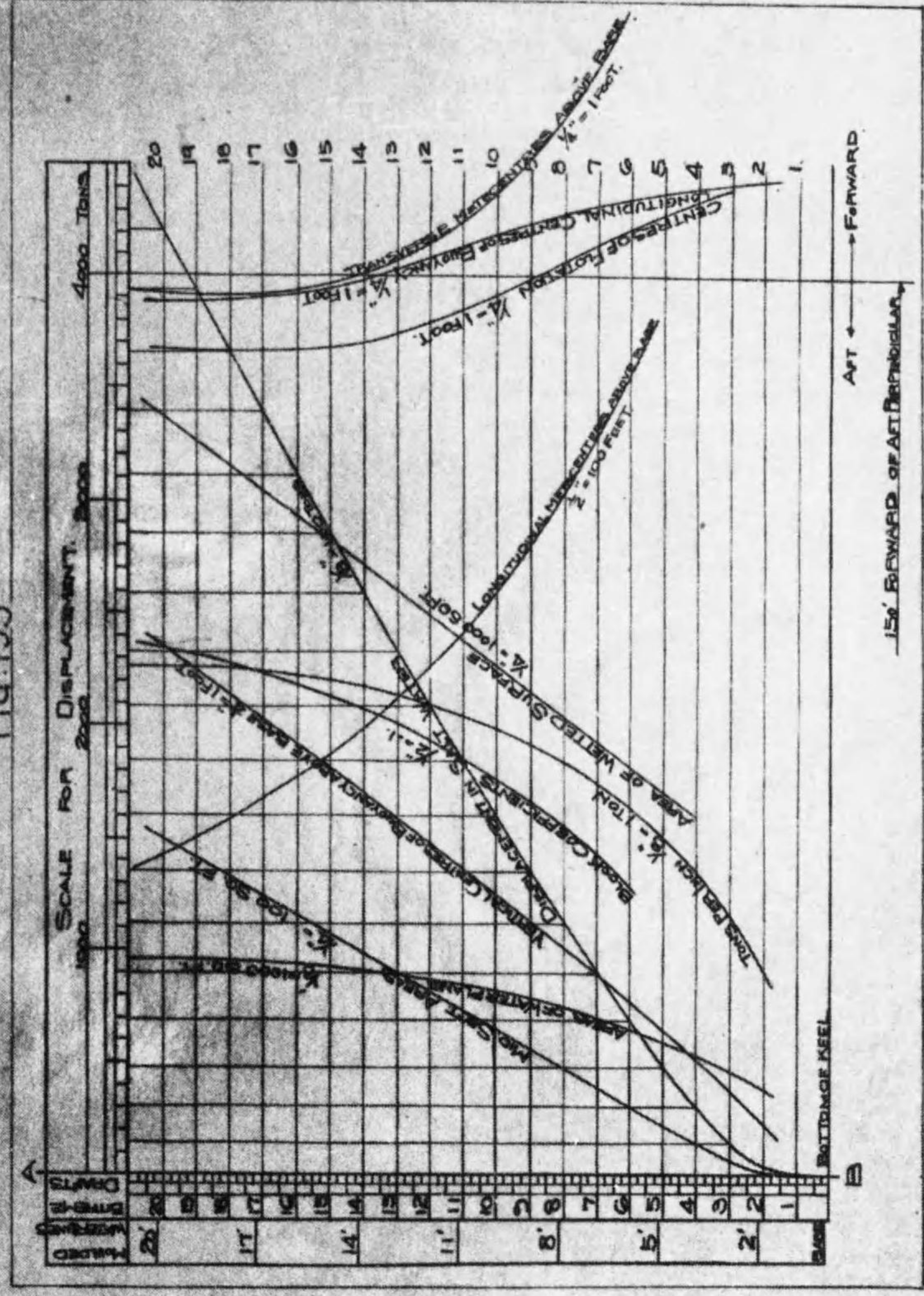
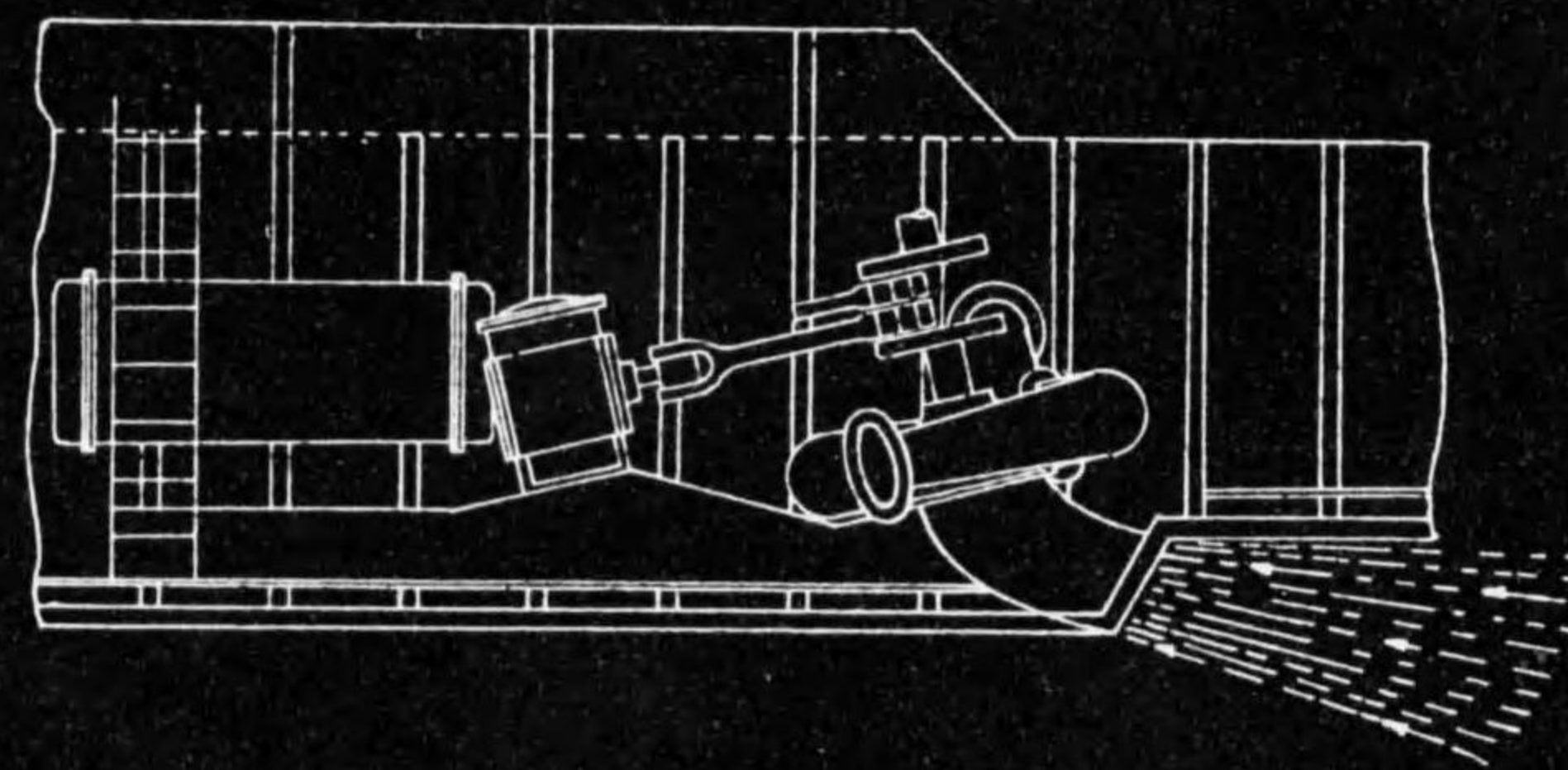
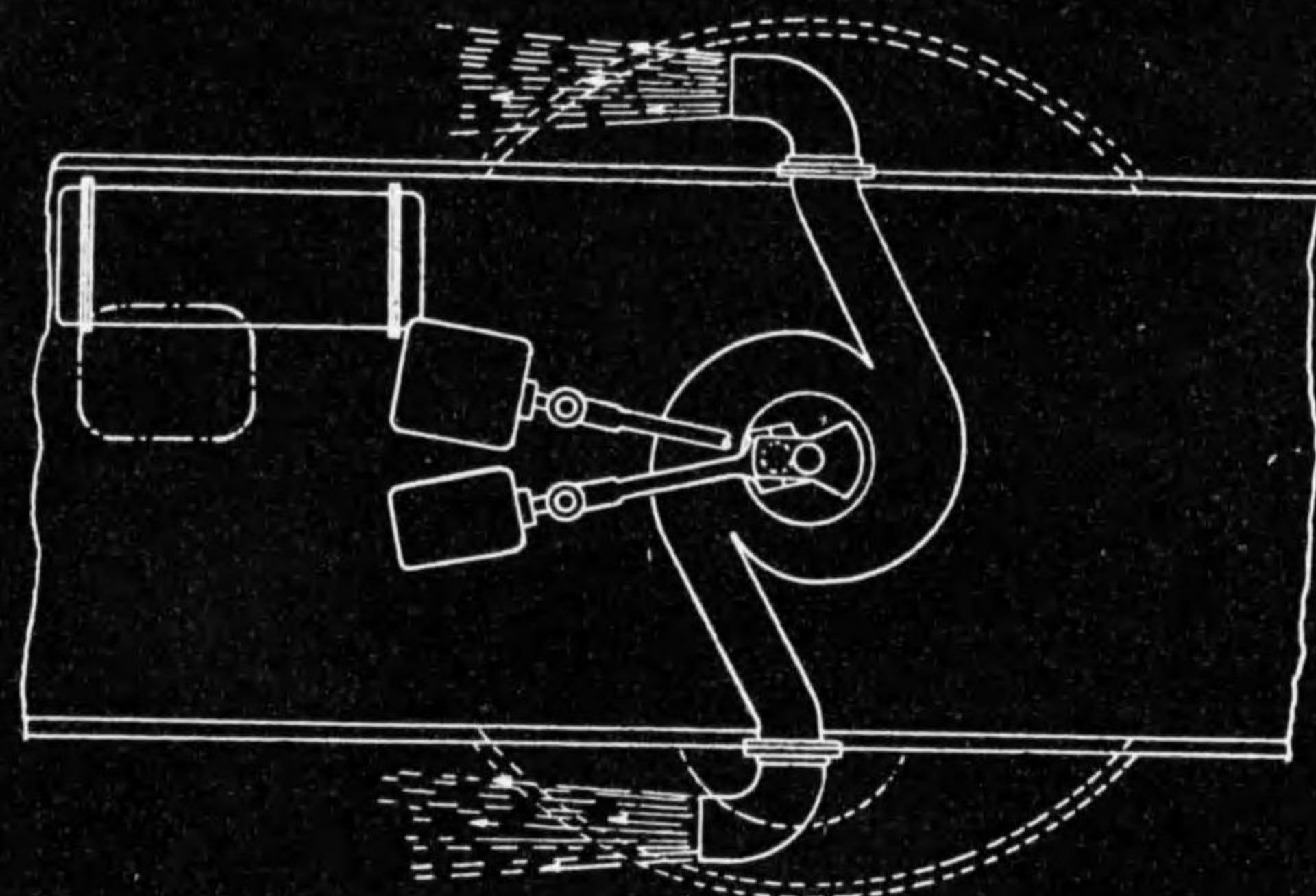

FIG. 160

JET PROPELLER



JET PROPELLER

FIG 160

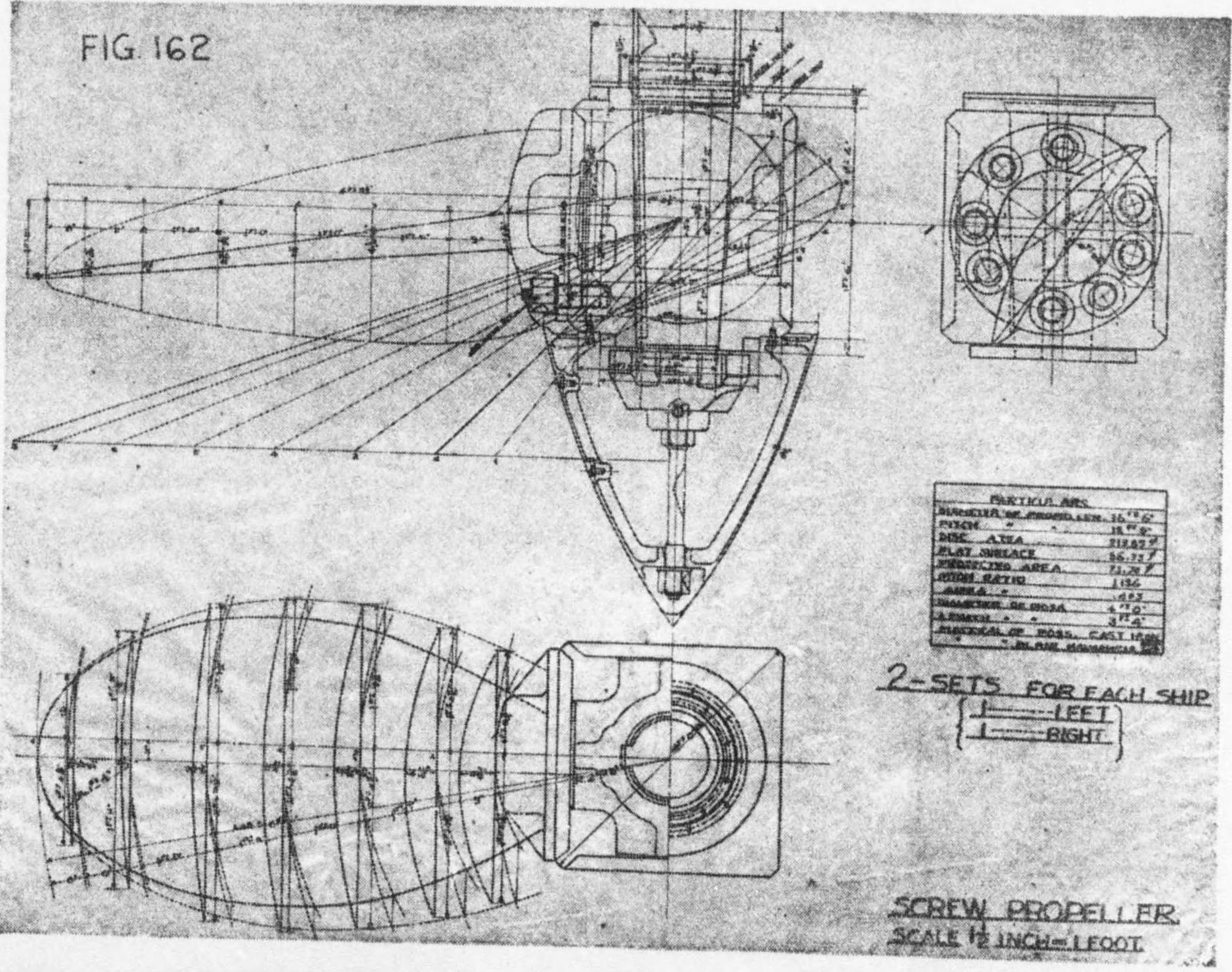
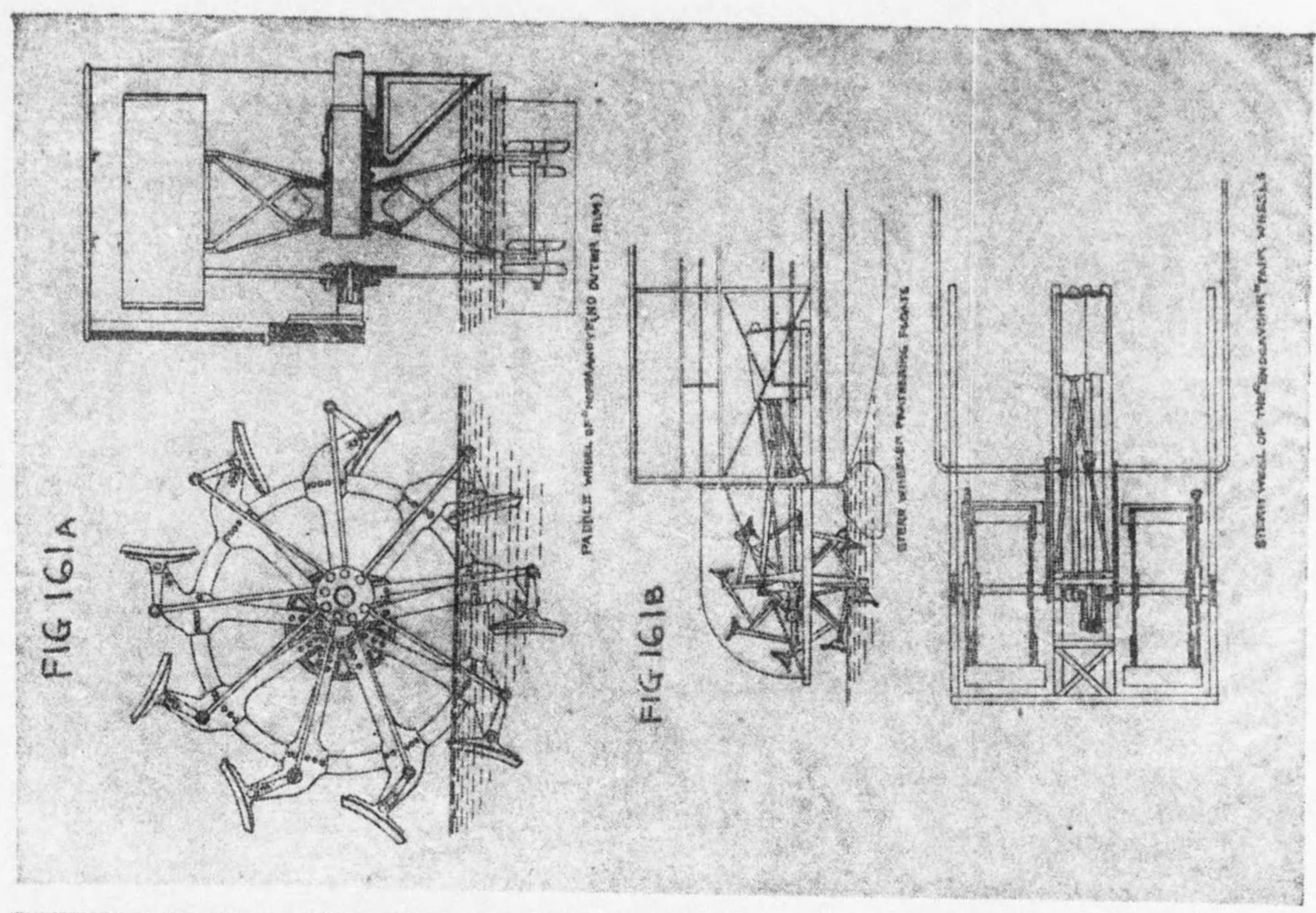
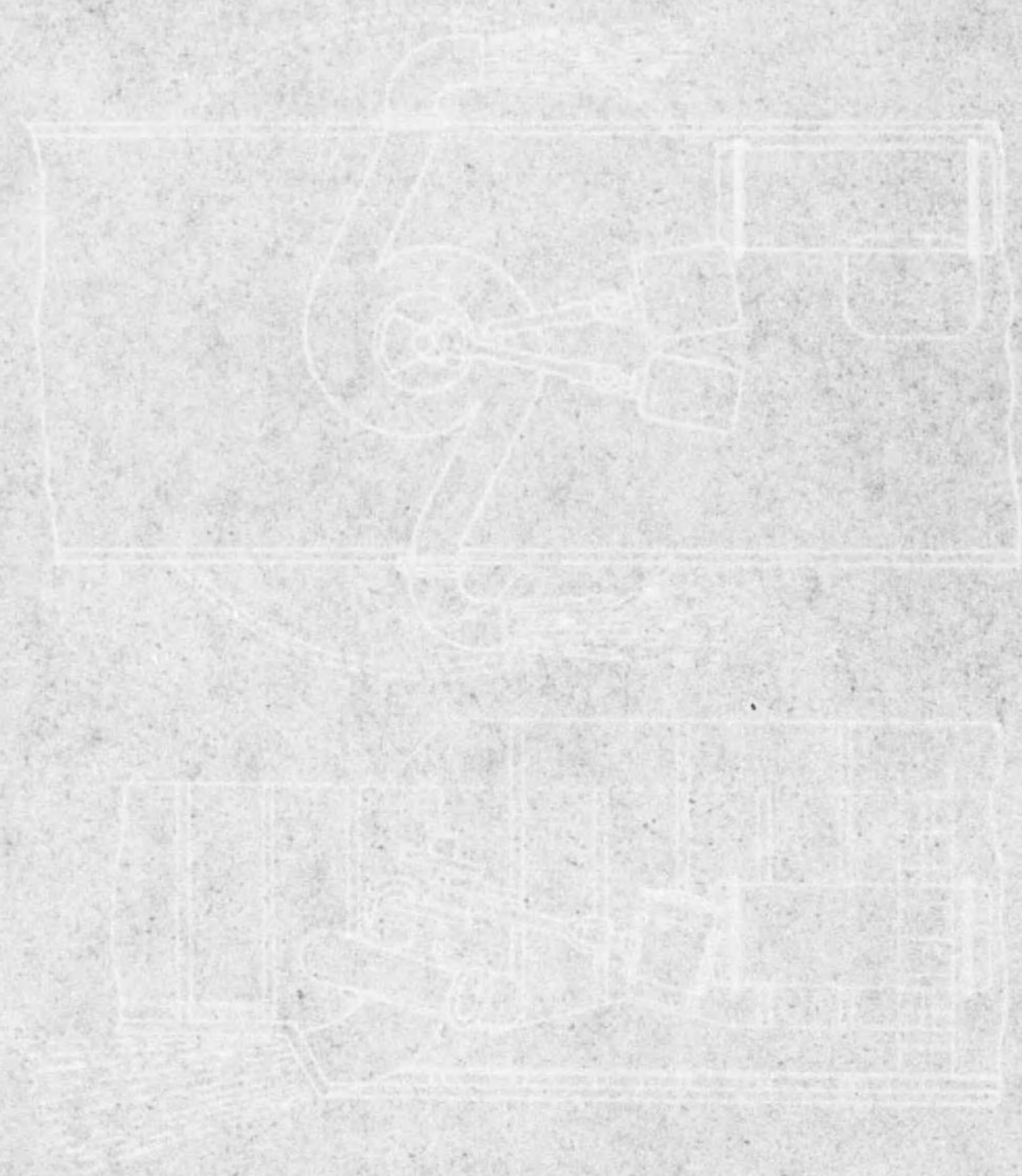
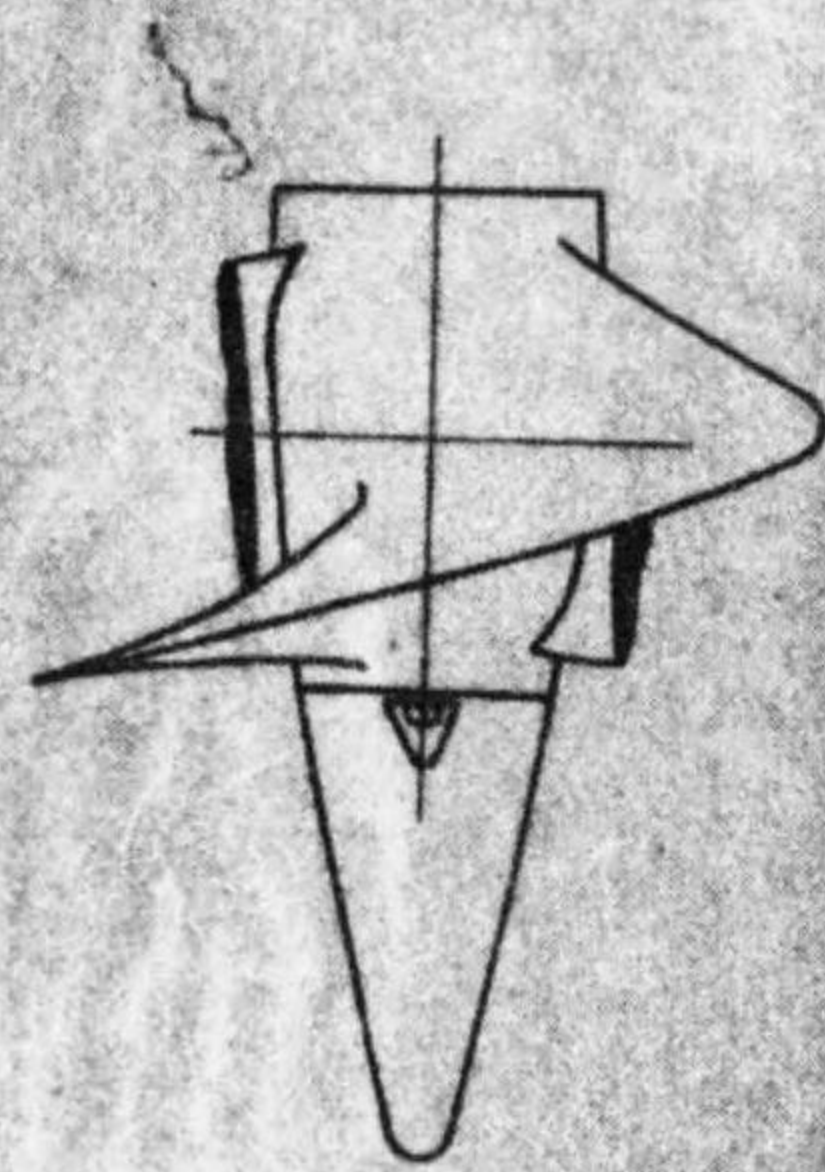
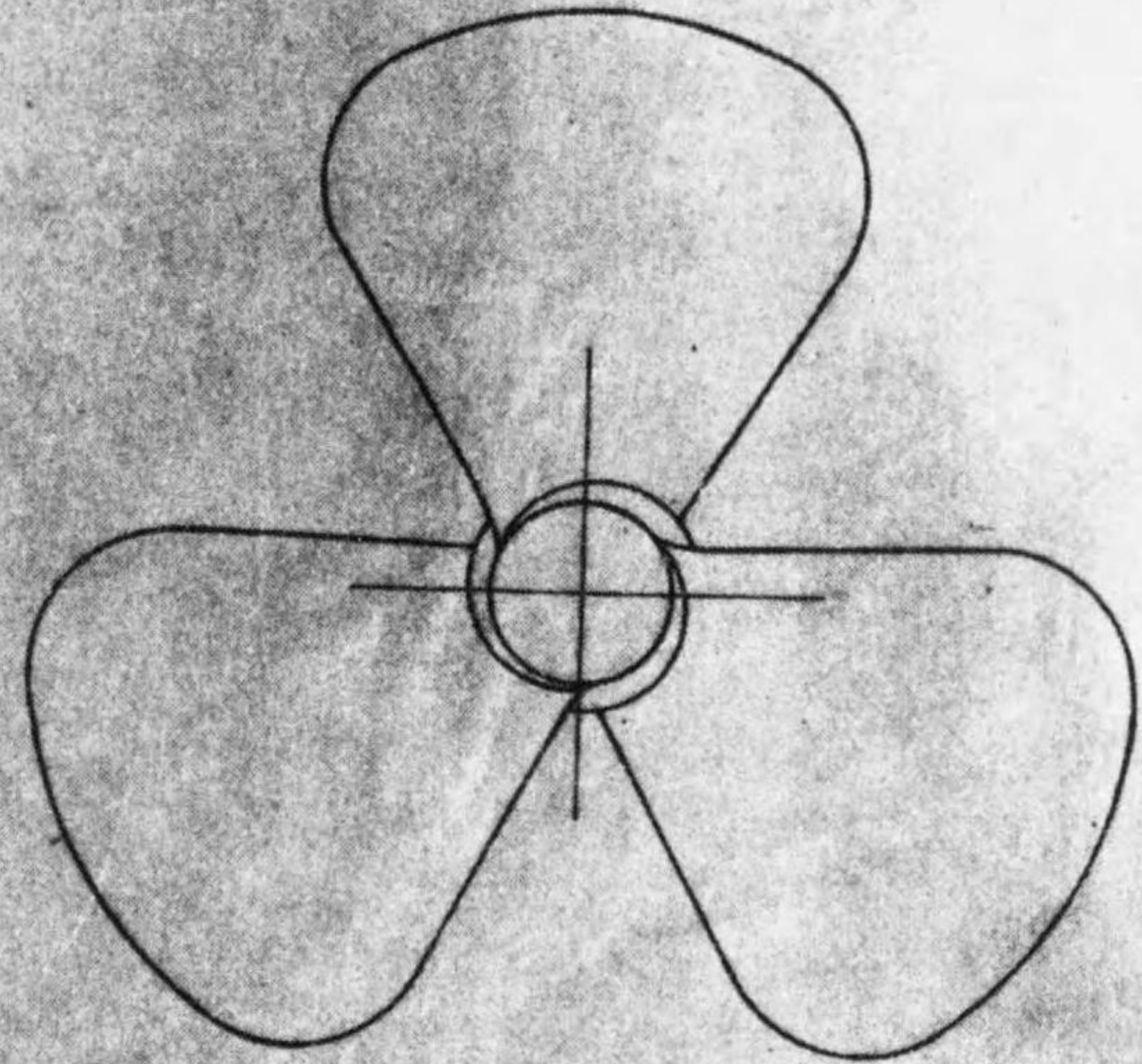

FIG. 163



BRONZE TURBINE TYPE PROPELLER
DIAMETER 8'-3" PITCH 6'-6"
PITCH RATIO .91 AREA RATIO .56
SCALE 1/4" = 1' PER FOOT

FIG. 164

ANALYSIS OF TRIAL RESULT

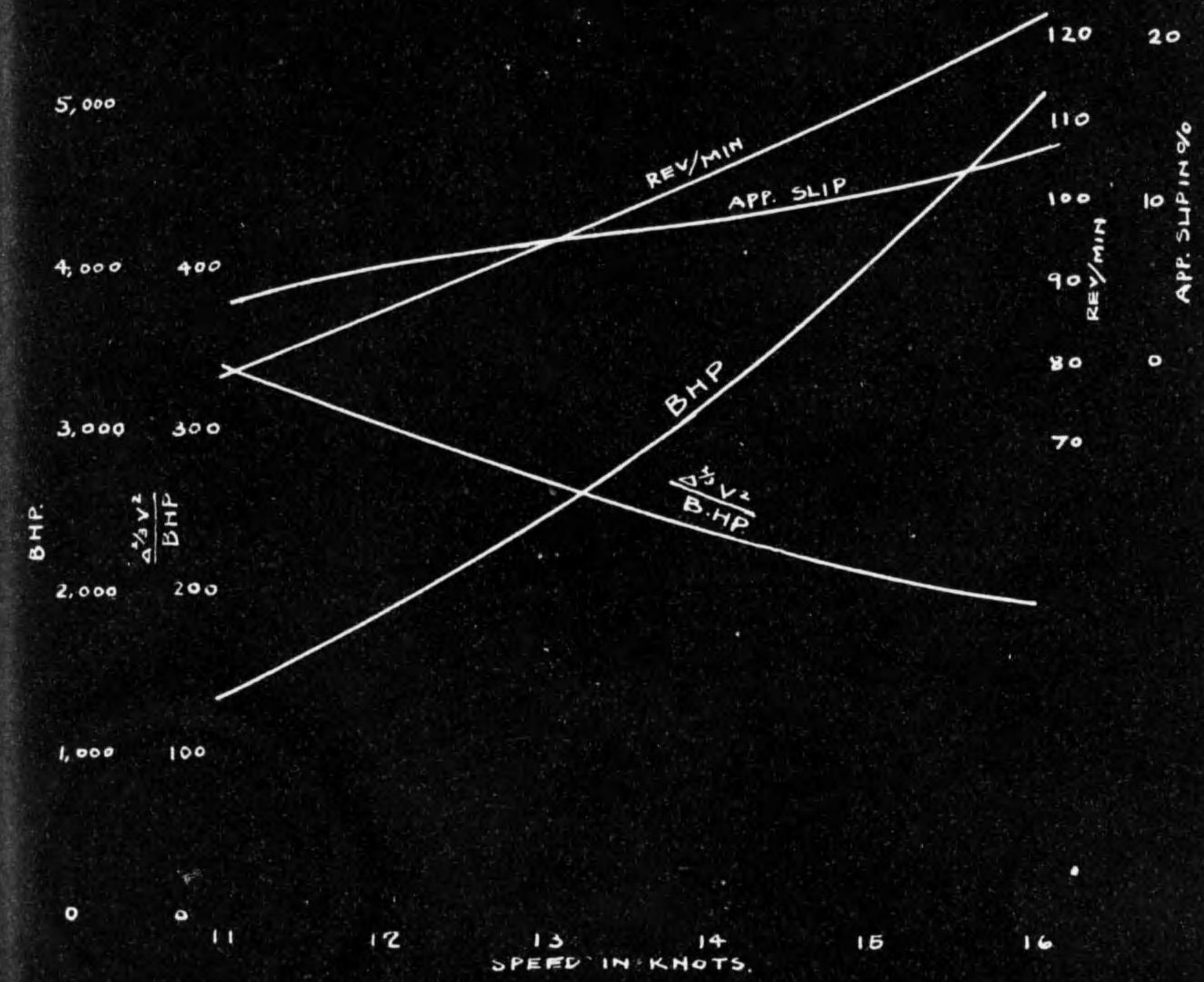
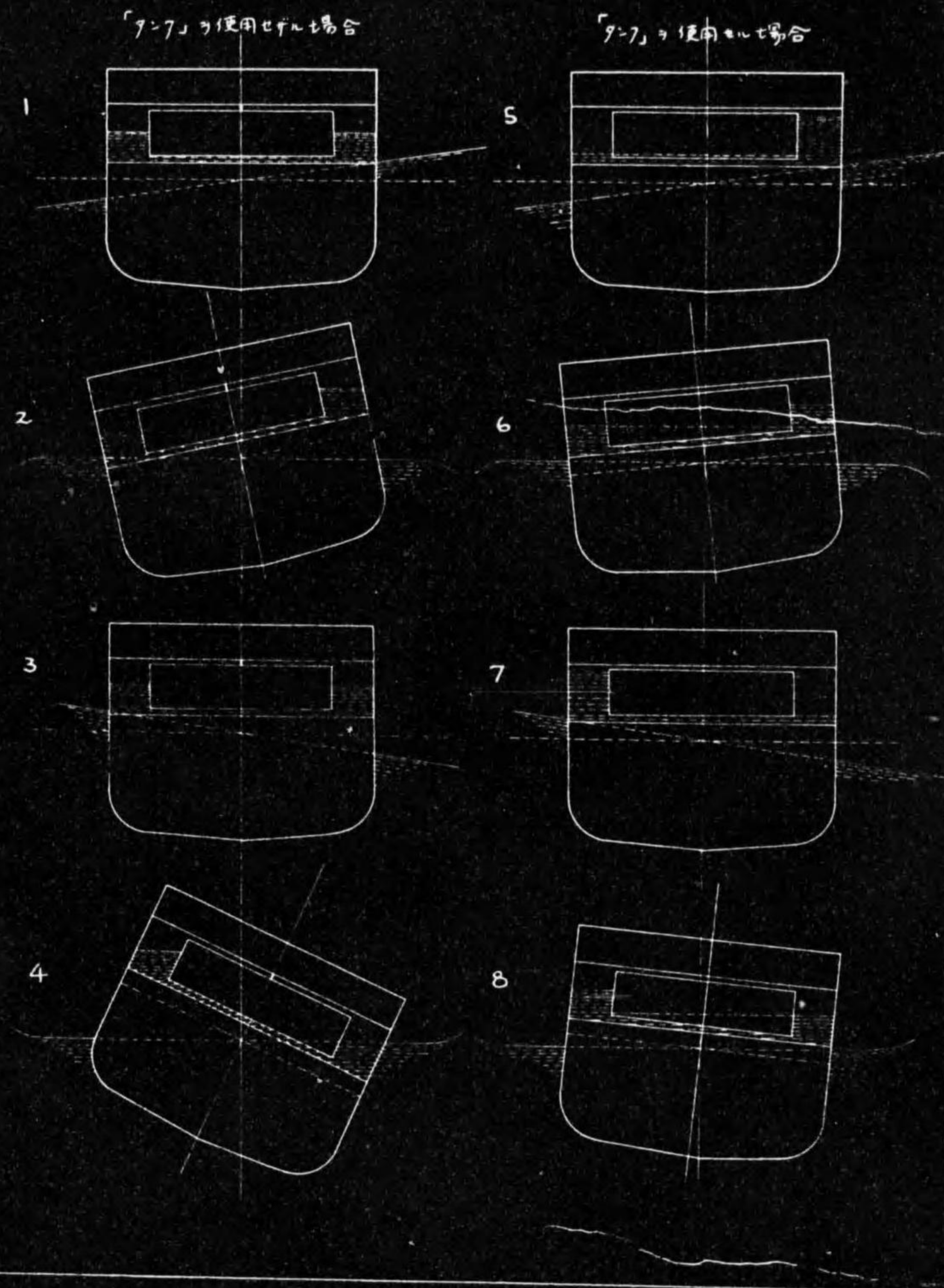

FIG. 165.

FRAHM'S UNTIROLLING TANK



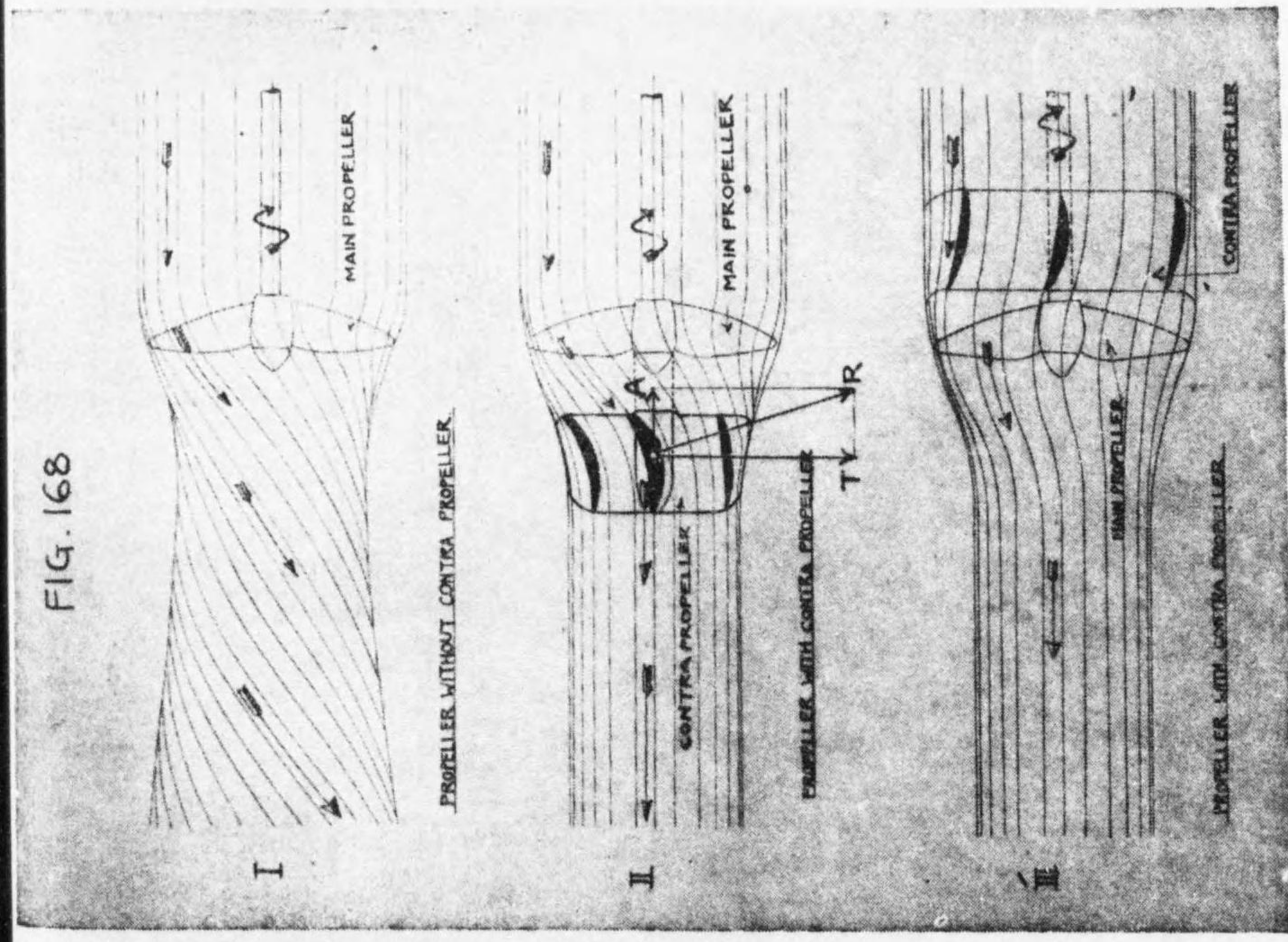
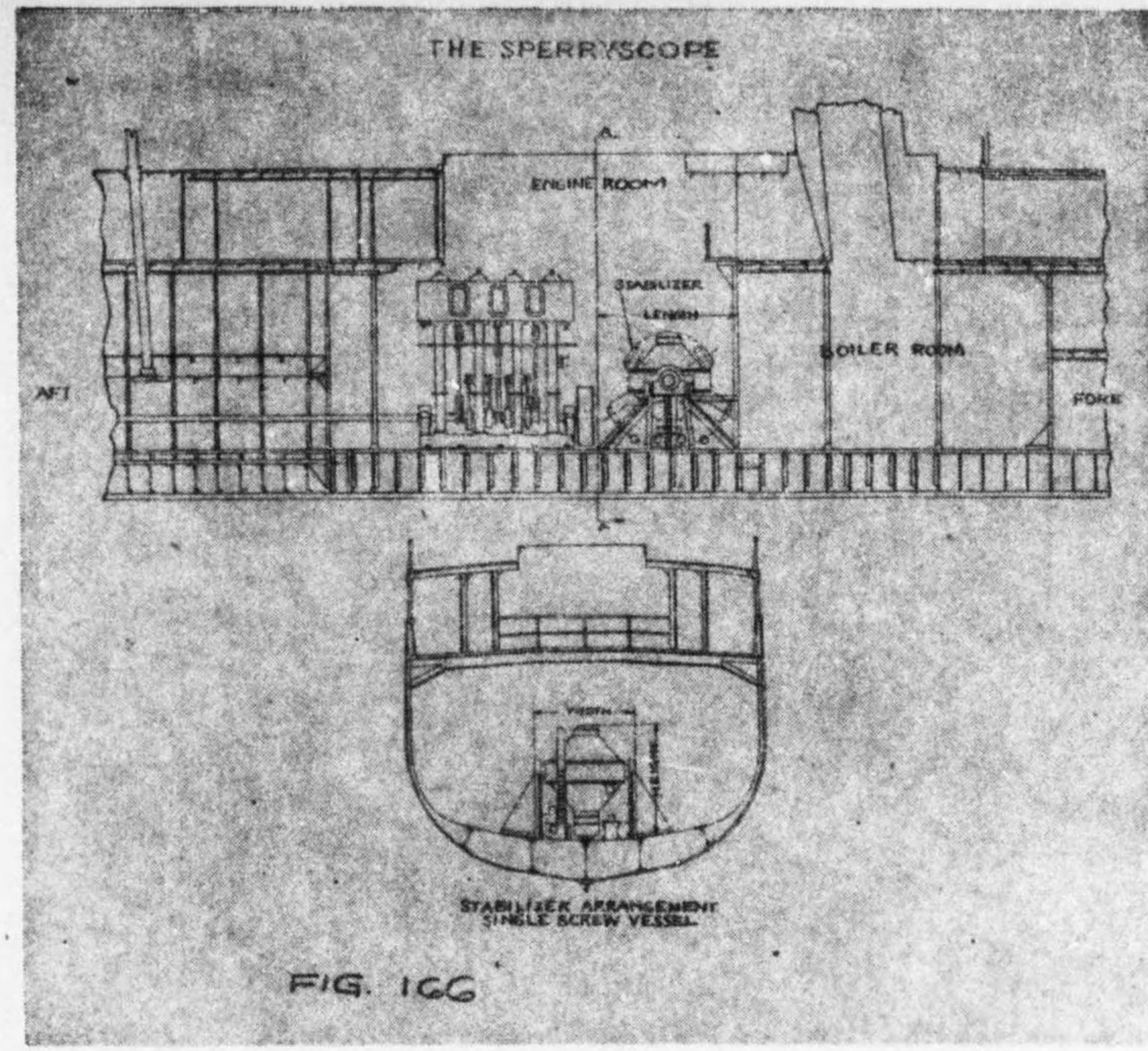
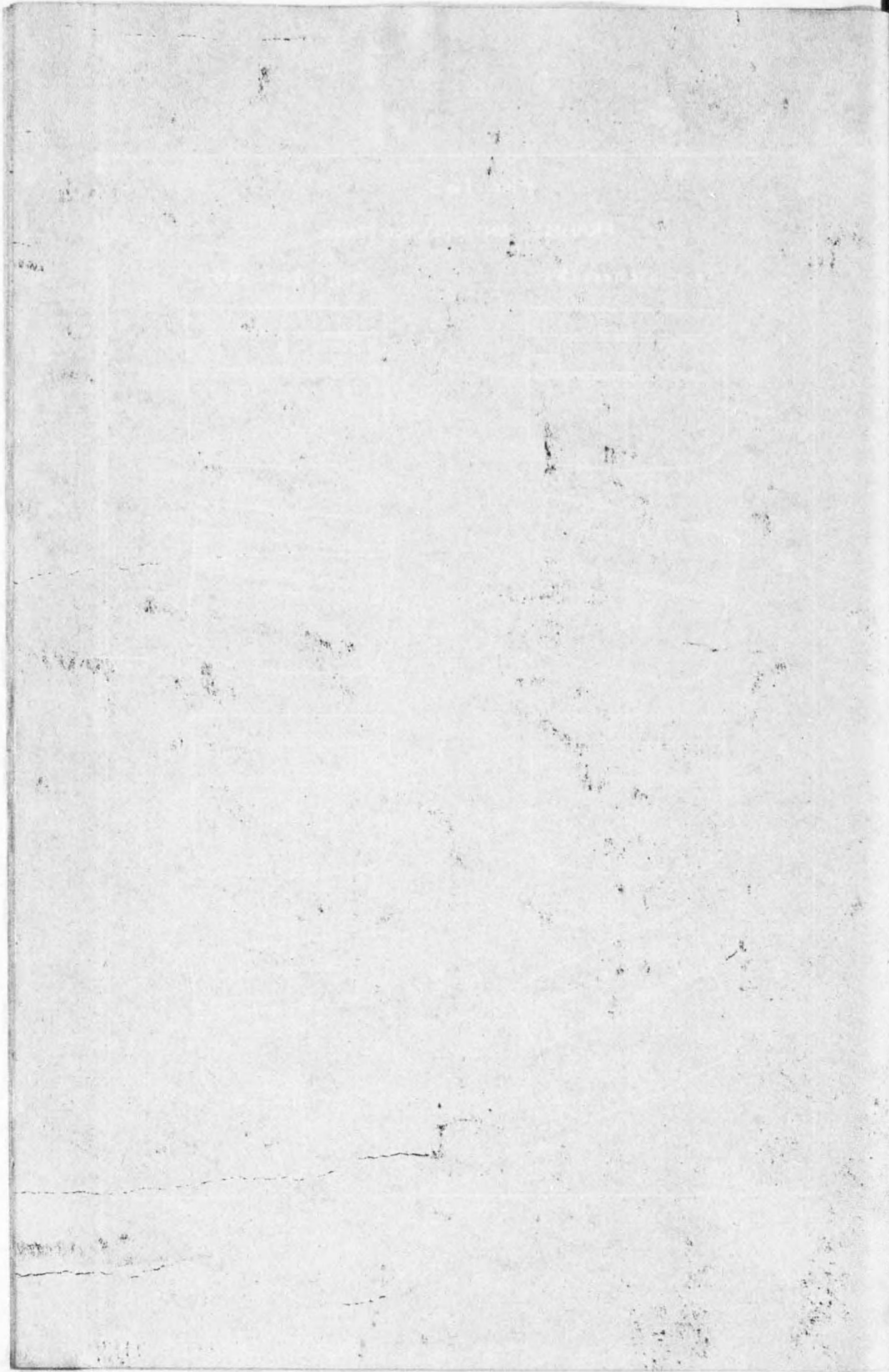
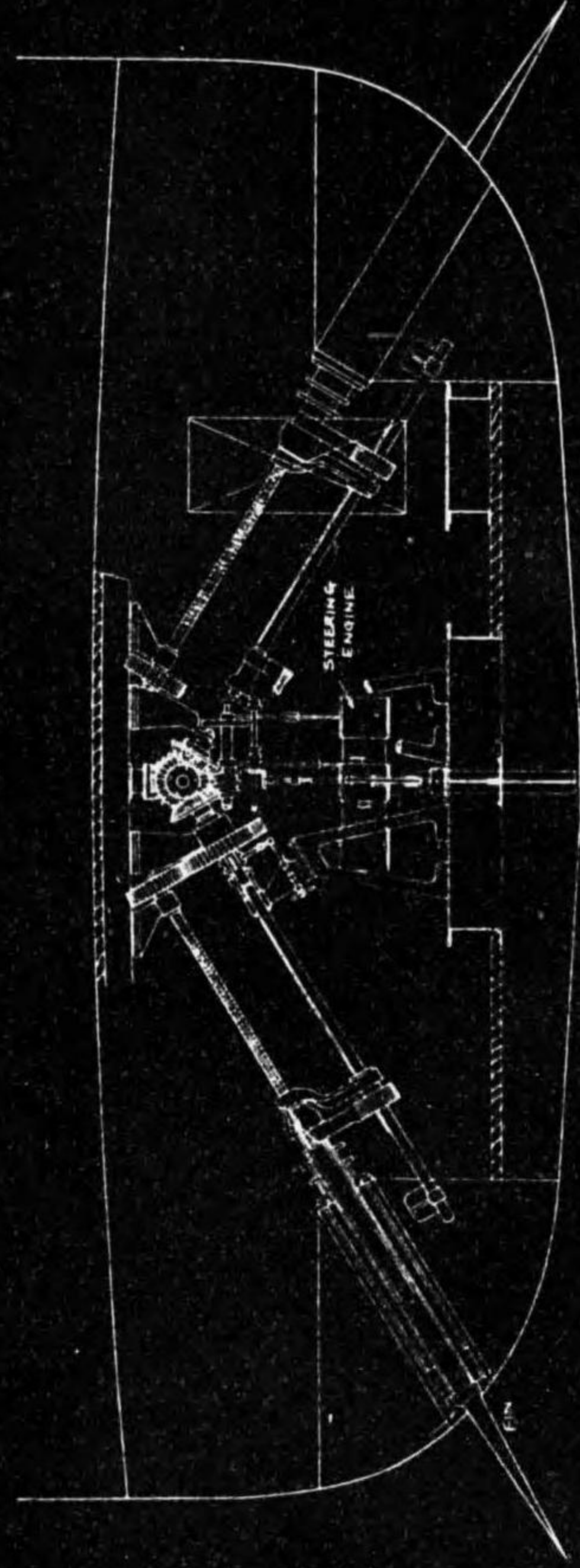
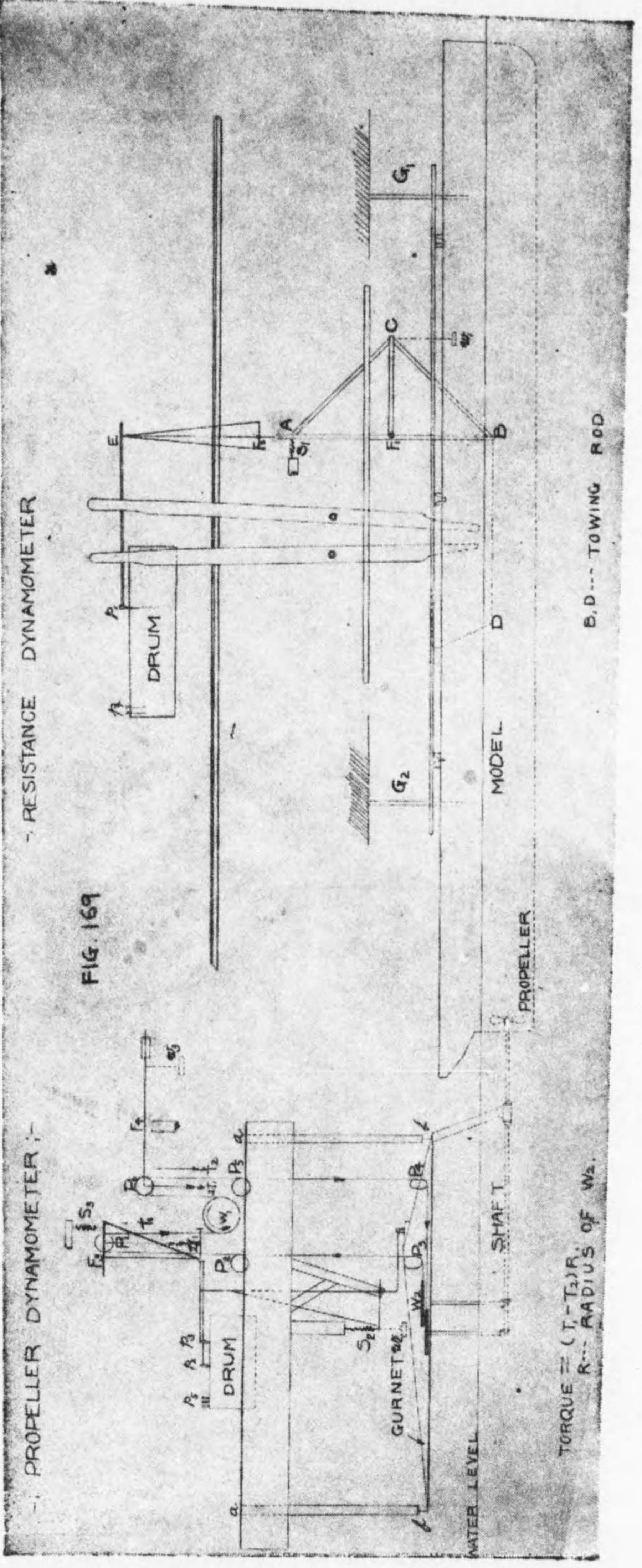
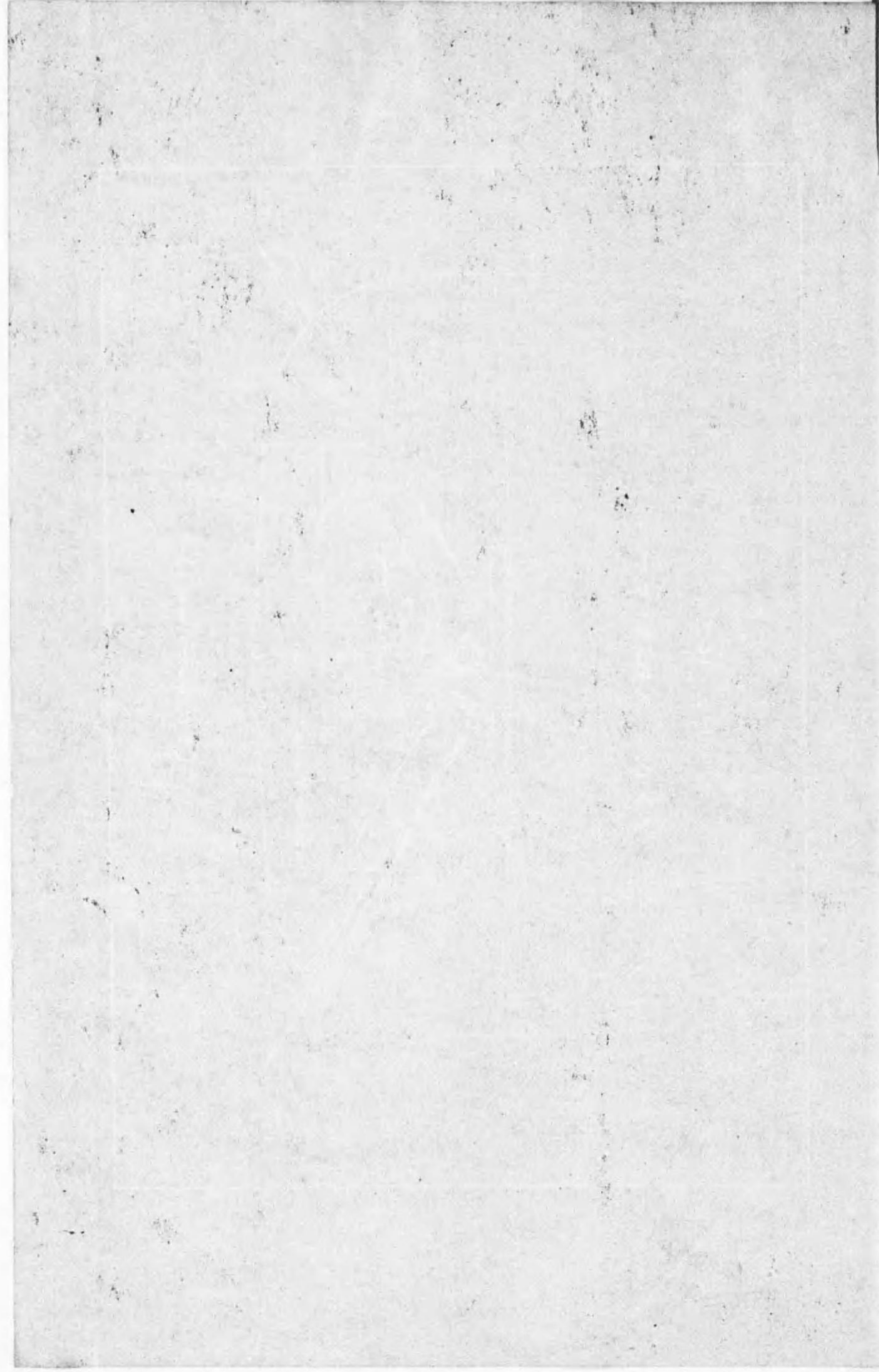

FIG. 167
元良式「ステライザー」



(S.S. MUTSU MARU)



SCOTCH BOILER
(SINGLE ENDED)

FIG. 170

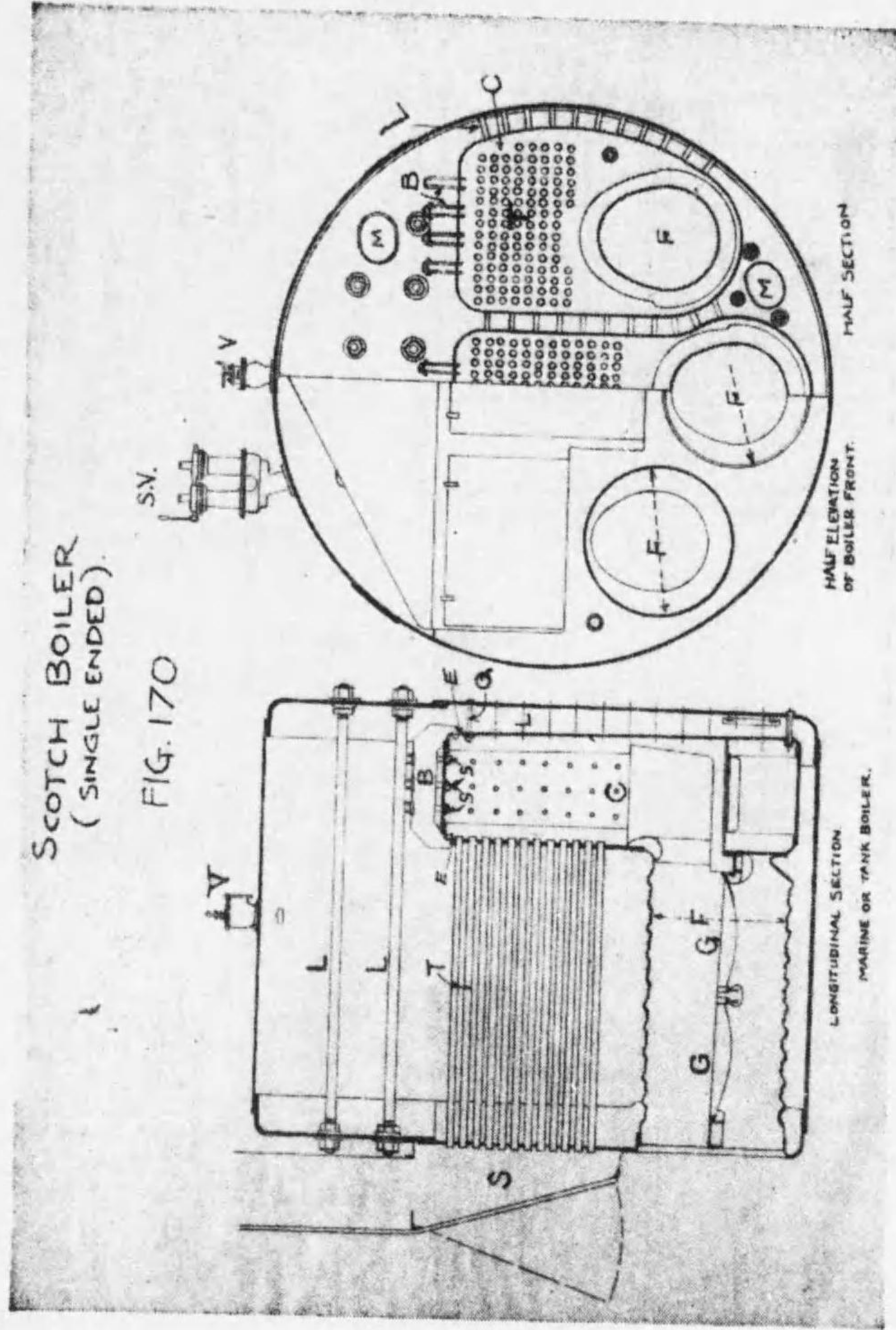



DOUBLE ENDED BOILER (FOX'S FURNACES)

FIG. 171

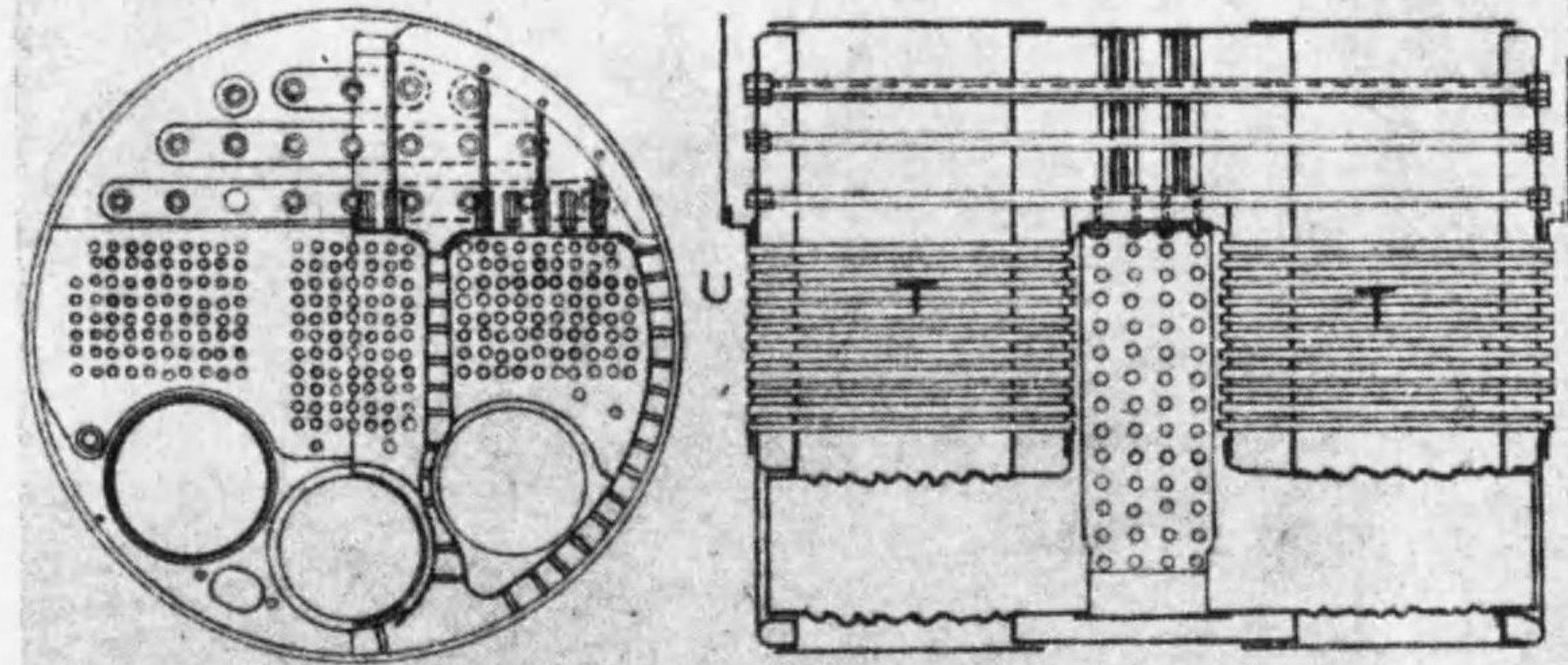

YARROW BOILER

FIG 172

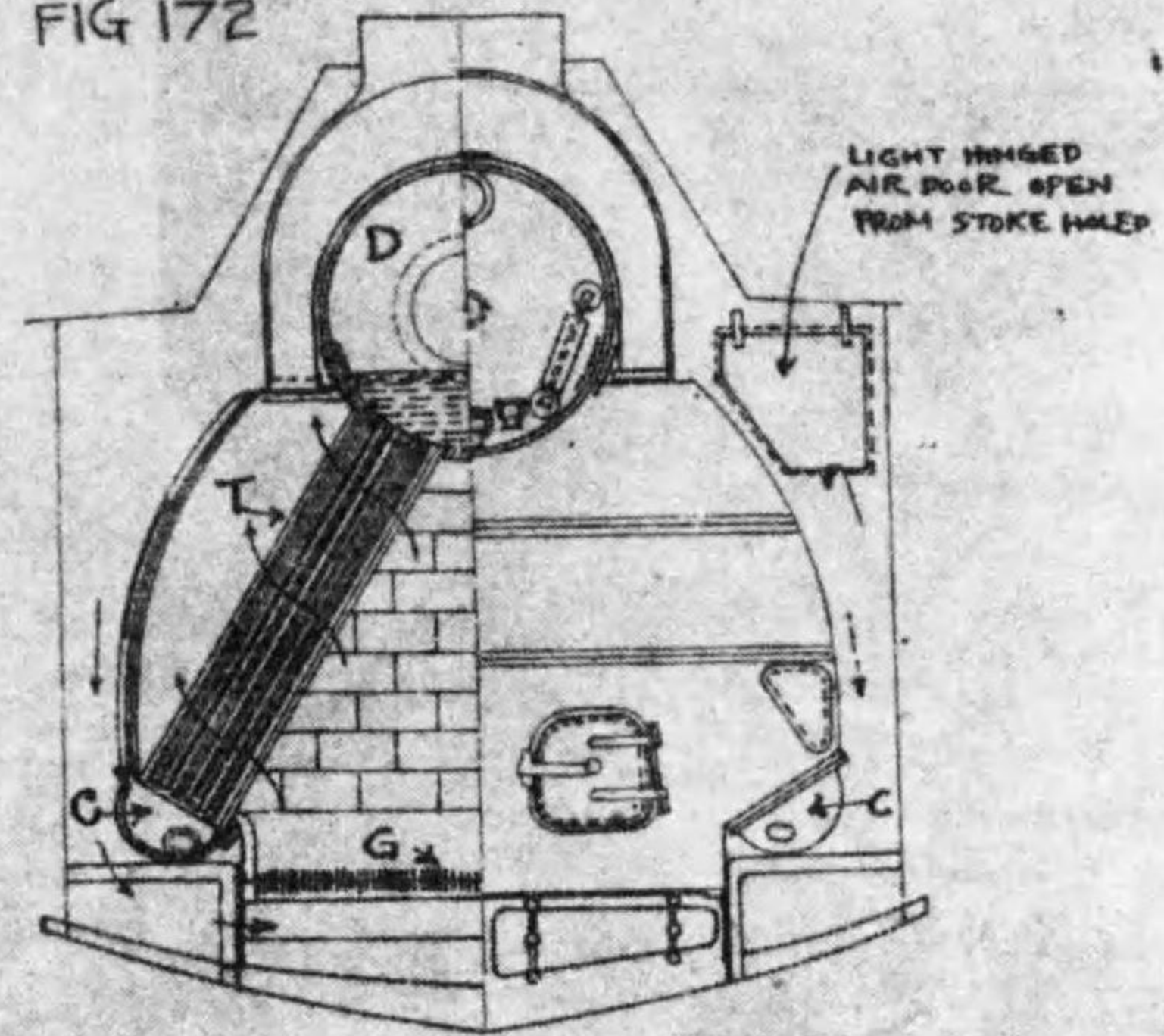



S.C. STEAM CHEST.
 S+S. STEAM PORT.
 E. EXHAUST PORT.
 S.V. SLIDE VALVE.

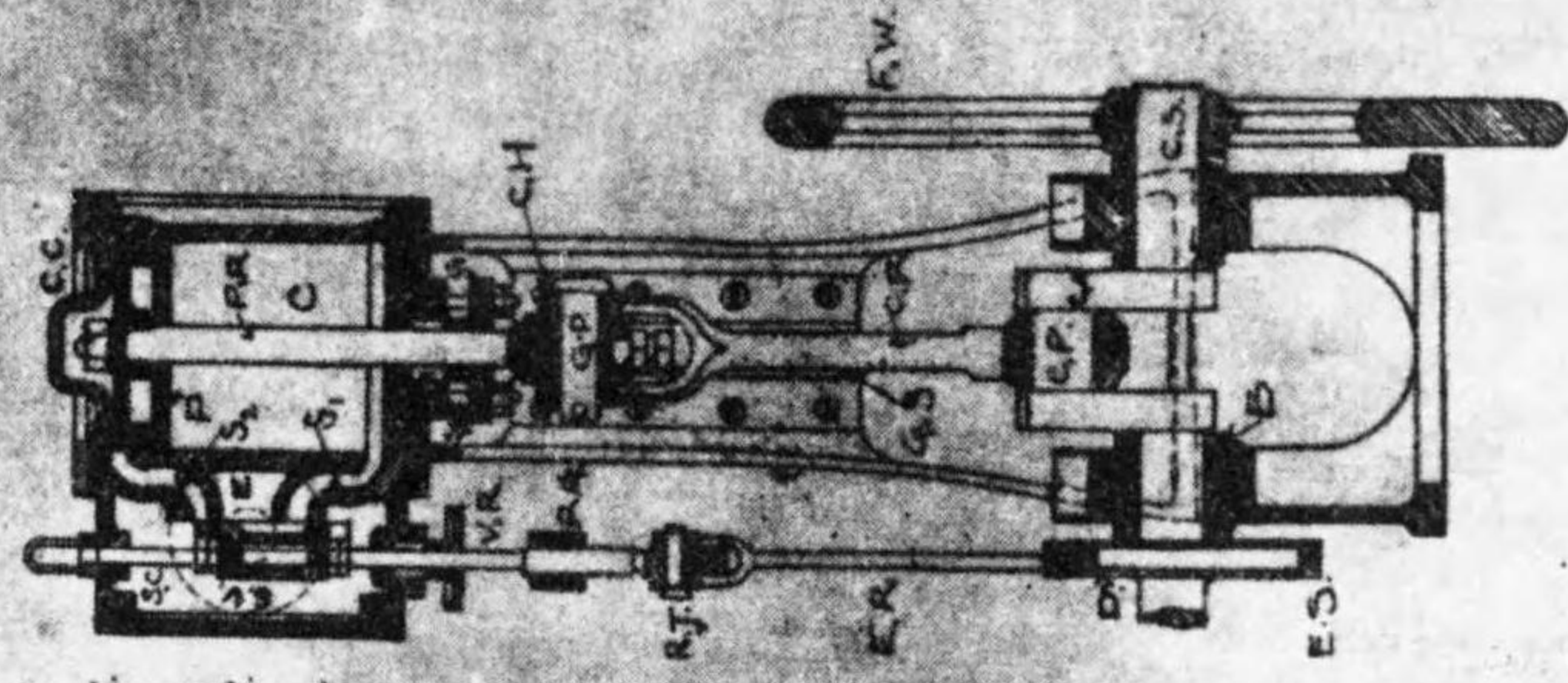
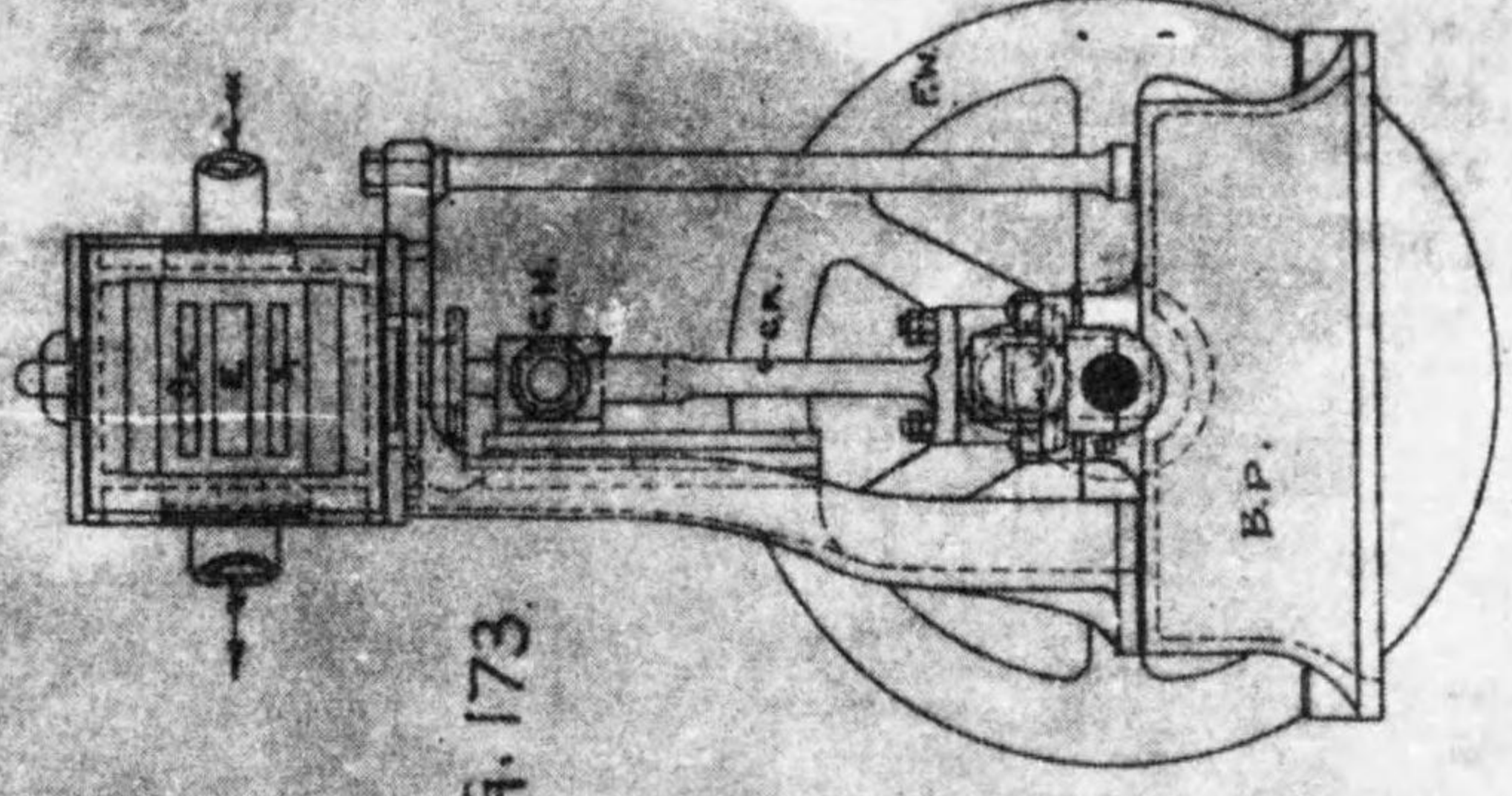
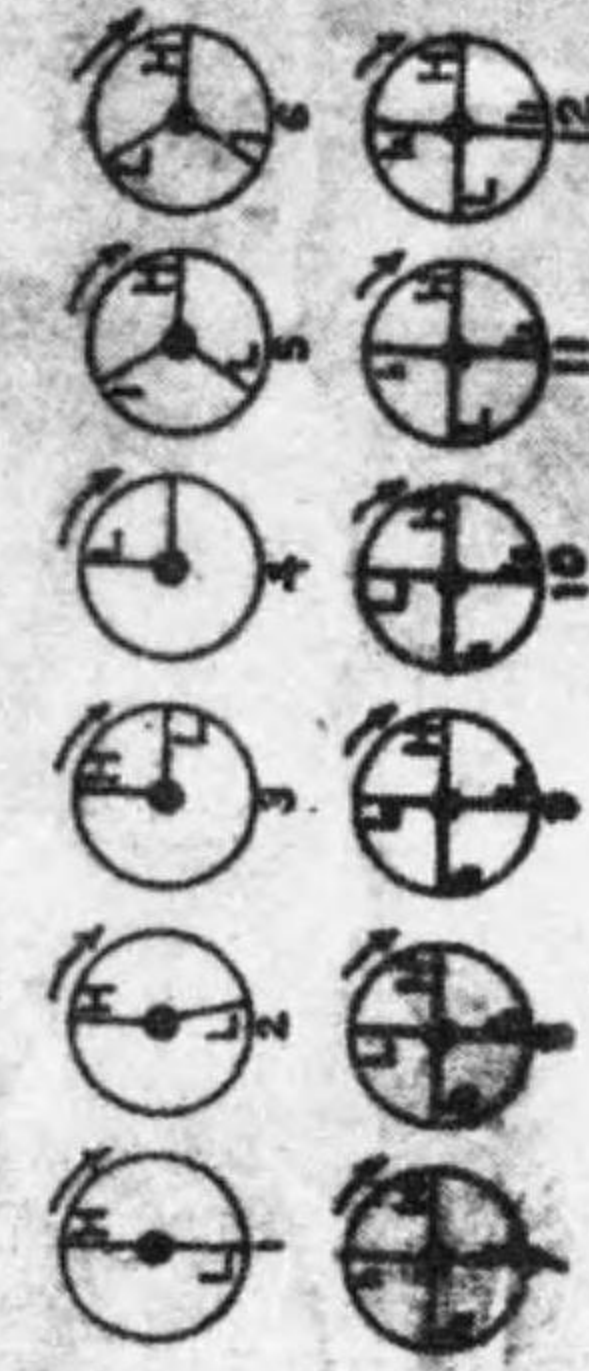

FIG. 173.



C. CYLINDER.
 C.C. CYLINDER COVER.
 P. PISTON.
 P.R. PISTON ROD.
 S.B. STUFFING BOX.
 G. GLAND.
 C.H. CROSS HEAD.
 B.P. BED PLATE.
 G.P. GUDGEON PIN.
 C.R. CONNECTING ROD.
 C.P. CRANK PIN.
 C.S. CRANK SHAFT.
 C.A. CRANK ARM.
 B. BEARING.
 F.W. FLY WHEEL.
 D. ECCENTRIC SHEAVE.
 E.S. ECCENTRIC STRAP.
 E.R. ECCENTRIC ROD.
 R.J. ROD JOINT.
 V.R. VALVE ROD.
 G.S. GUIDE SHOE.

FIG. 174.



DOUBLE CRANK ARRANGEMENTS

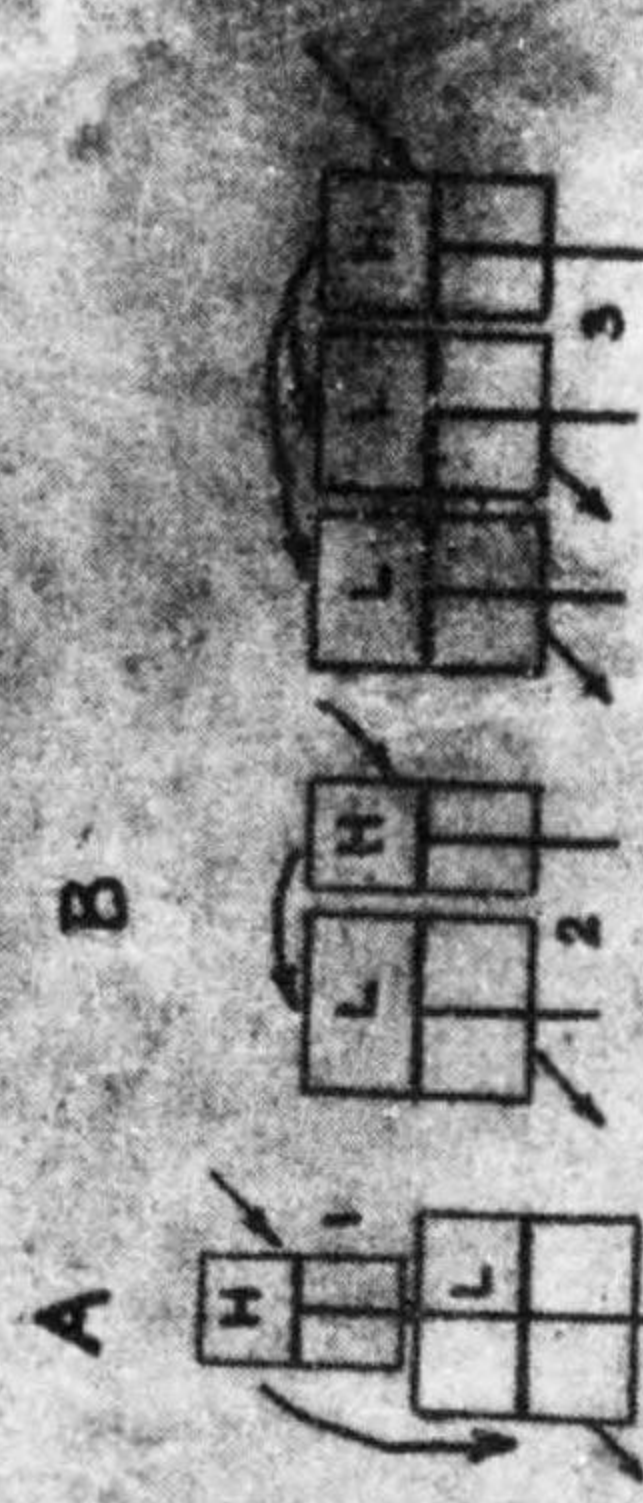

CYLINDER ARRANGEMENTS FOR COMPOUND ENGINE

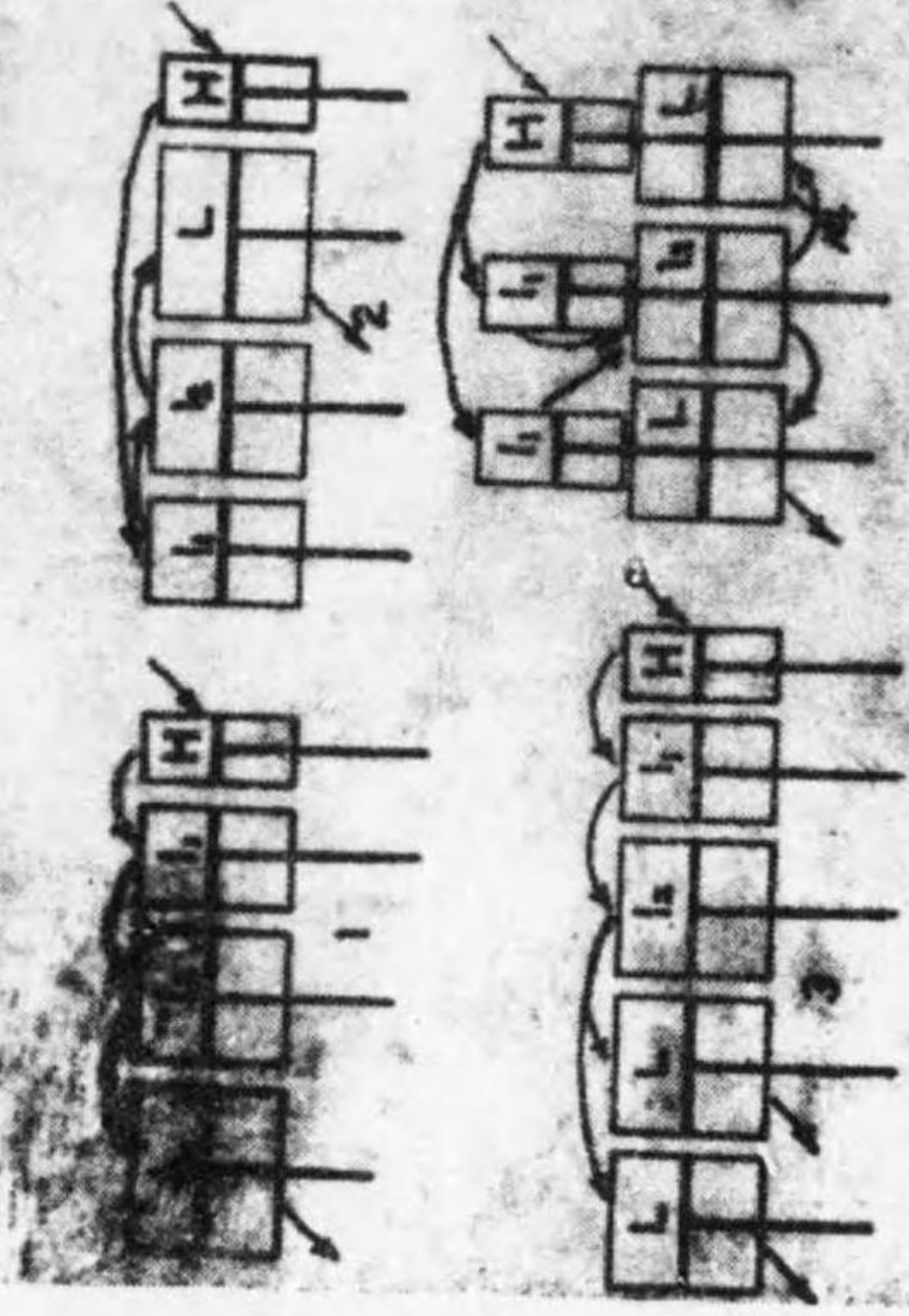

CRANK ARRANGEMENTS FOR QUADRUPLE EXPANSION ENGINE

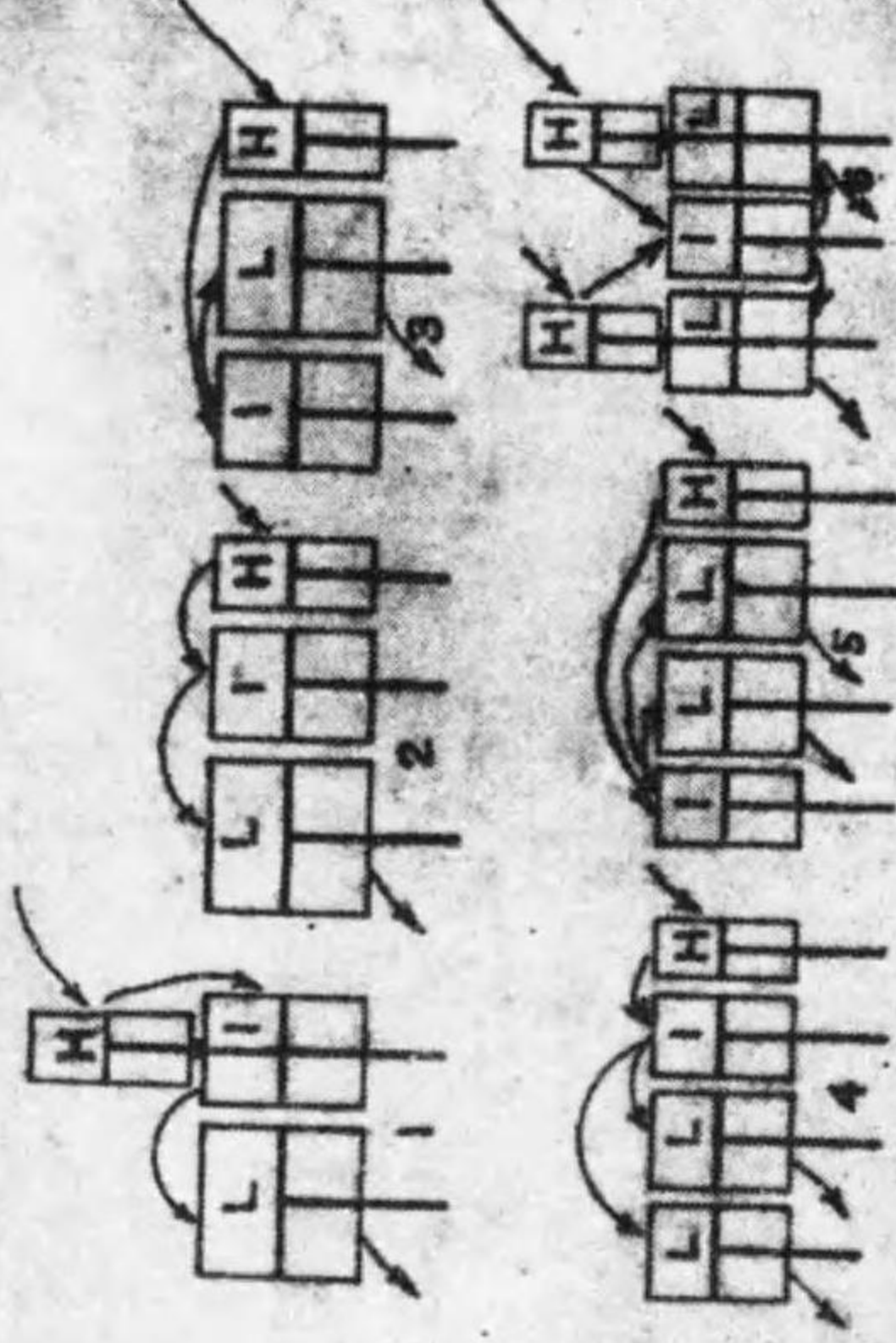

CYLINDER ARRANGEMENTS FOR TRIPLE EXPANSION ENGINE