

PERIODICAL DEPARTMENT X

SUTRO  
STACKS

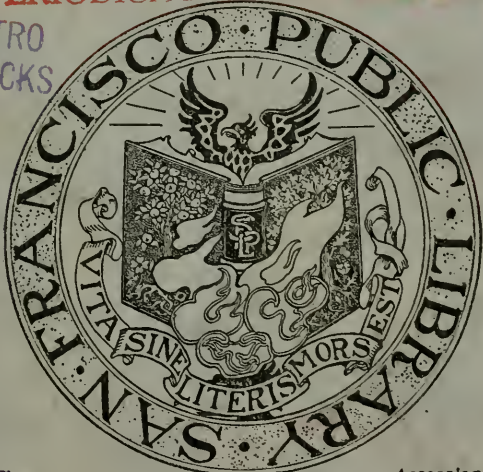

Class

Accession

352 P 11 23 + 24 64067

NOT TO BE TAKEN FROM THE LIBRARY



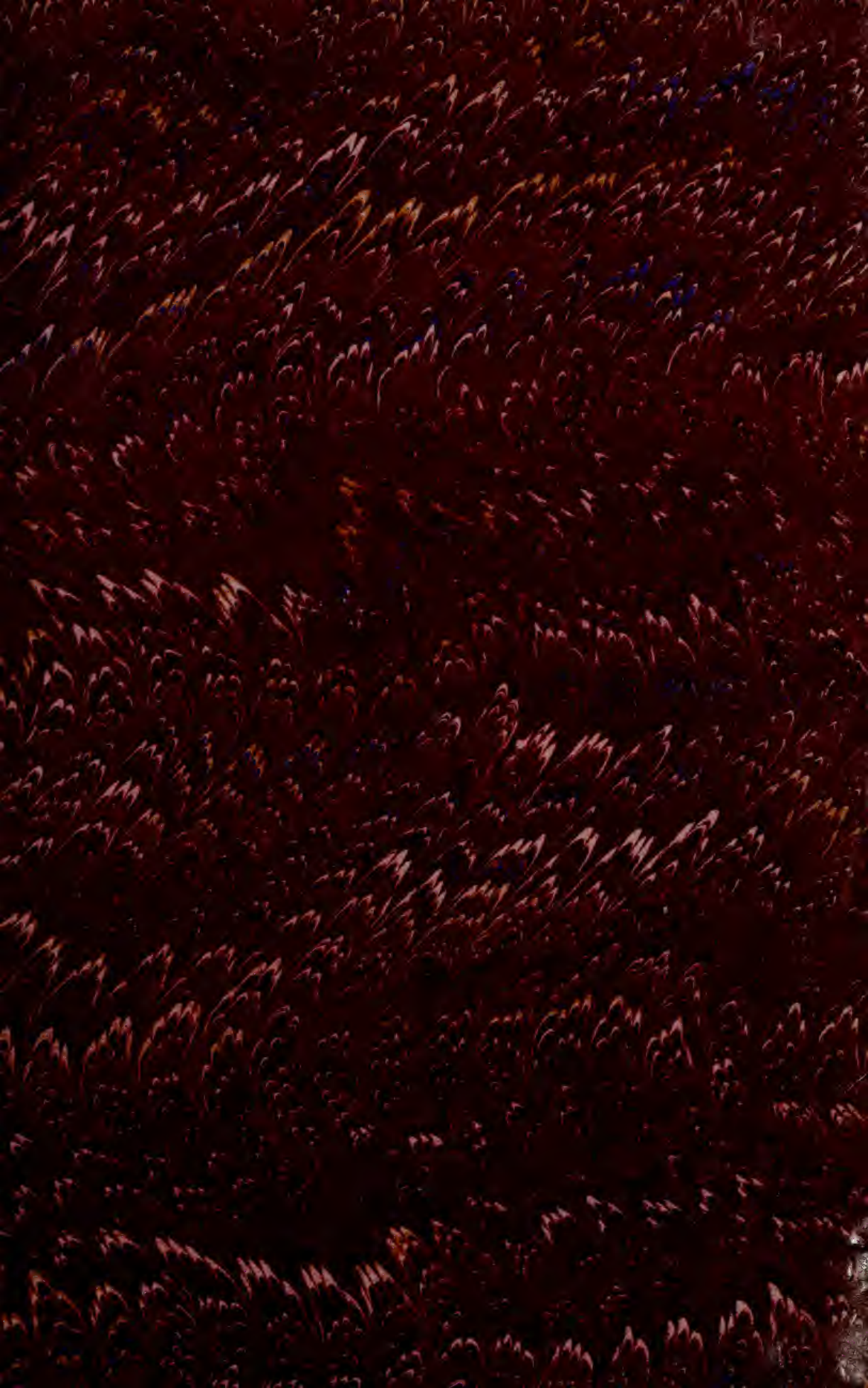

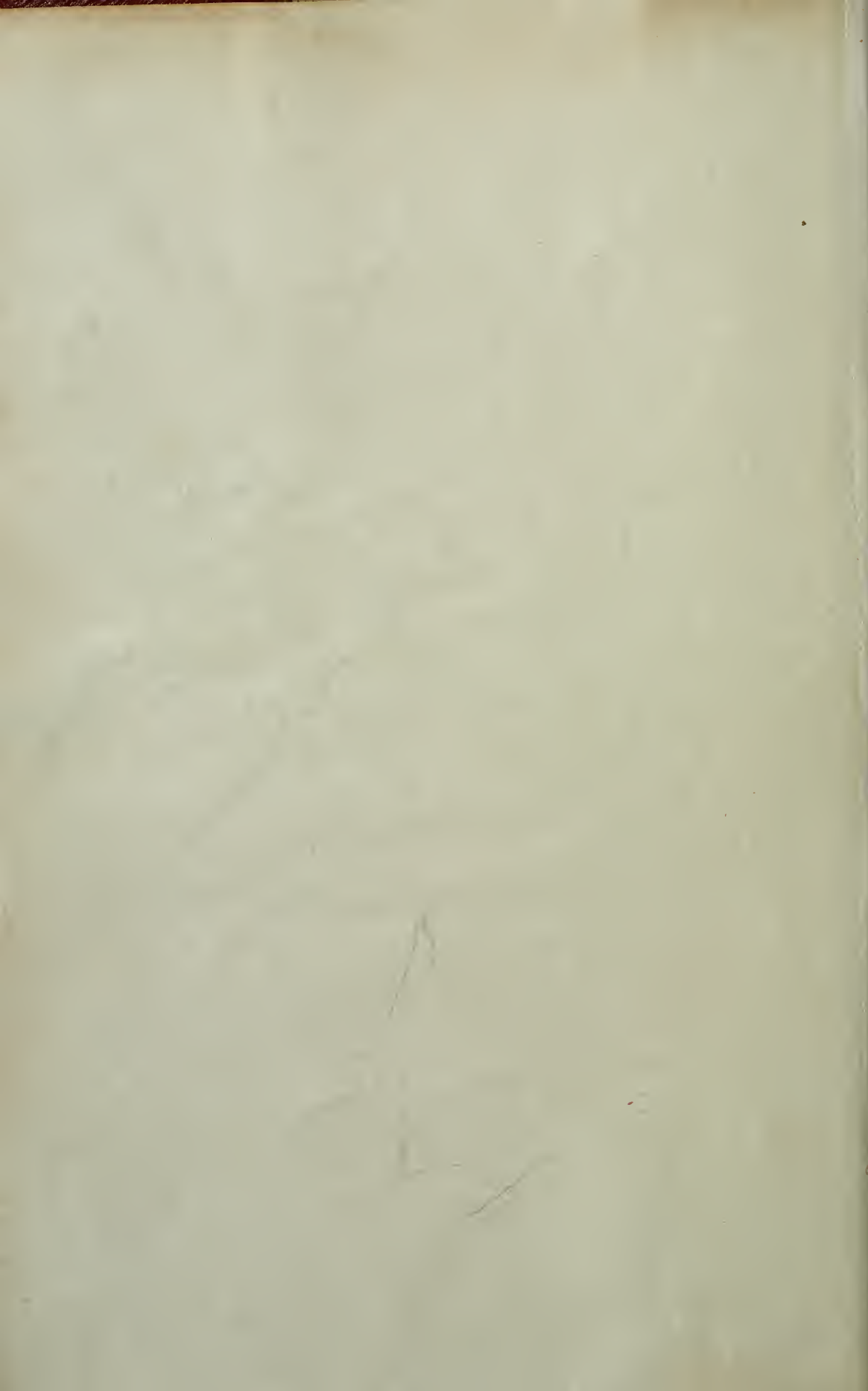



note -

Index to volumes 23 and 24 on pages  
228 and 229 of volumes 25 and 26.

Handwritten text at the top of the page, possibly a title or header, which is mostly illegible due to fading and blurring.









AUGUST 31, 1910

20 Cents

# PACIFIC MUNICIPALITIES

## THE CITY BEAUTIFUL



PUBLIC  
SAFETY  
HEALTH  
CONVENIENCE

PUBLIC  
UTILITIES  
EDUCATION  
RECREATION

PUBLISHED MONTHLY

SIERRA 5-F

*Our Office* IS NOW AT  
336 Pacific  
Electric Build-  
ing, Los Angeles, Cal., where we  
shall be glad to see all road men, and  
to receive orders for our special road  
machinery--Case Rollers and Dump  
Wagons, Graders & Street Sweepers

---

## PETROLITHIC PAVEMENT CO.

336 Pacific Electric Bldg., Los Angeles, Cal.

---

## PATRONIZE OUR ADVERTISERS

Members of the League can Materially assist the upbuilding of our organ, Pacific Municipalities, by favoring our Advertisers wherever possible. Our advertisers are always pleased to answer inquiries.

Mention Pacific Municipalities when writing to them.

---

## == A. CARLISLE & CO. ==

Stationers, Printers and Bookbinders

We specialize in Bonds, Steel Die, Lithographed or Printed, for Municipalities or Counties, and the Books and Forms required by all Municipal Officers.

251-253 Bush Street

San Francisco, Cal.

---

Please mention PACIFIC MUNICIPALITIES when writing to Advertisers



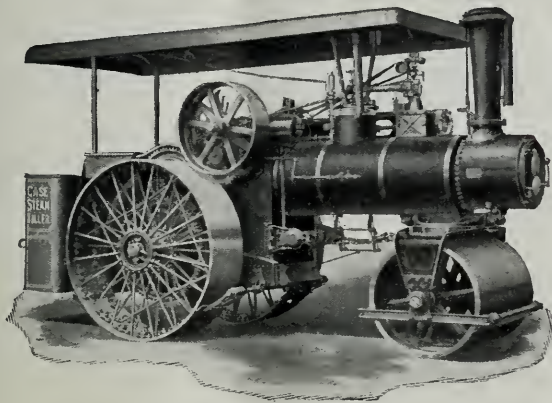

# CASE

36 Horse Power

10 Ton Road Roller

Time Price--with Simple Cylinder

**\$2,200**

with Compound Cylinder

**\$2,300**

10 per cent Discount for Cash.

**The Only Spring-Mounted Road Roller Built**

Case Rollers have greater fuel and water capacity than others

---

**We sell the well known line of TROY Dump Wagons and Dump Boxes**

---

Road Rollers—Catalog 36. Contractors' General Purposes Engine and Municipal Tractor—  
Catalog 37. Address Road Machinery Dep't.

**J. I. CASE THRESHING MACHINE COMPANY, Inc.** RACINE, WIS.,  
U. S. A.

OAKLAND, CAL., BRANCH OFFICE, 616 MYRTLE ST.

Insure your Valuable  
Papers with

## Parcells Safe Co.

AGENTS

**"Diebold" Safes and "Allsteel" Metal Furniture**

577 MARKET STREET

SAN FRANCISCO

---

*Especially for Municipal Exploitation*

---



*Write to Us*

# *Sierra Art & Engraving Co.*

*Front and Commercial Sts., San Francisco*

# Henshaw, Bulkley & Co.

## ROAD MACHINERY

### A SPECIALTY

19-21 Fremont Street  
San Francisco

262-264 So. Los Angeles St.  
Los Angeles

# The Commercial Art Co.

INCORPORATED

## Designers & Engravers

53 Third Street

San Francisco

TERRA COTTA, PRESSED BRICK, PIPE,  
FIRE PROOFING, ROOFING TILE,  
FLUE LININGS, FIRE TILE,  
LAUNDRY TRAYS,  
ETC.

**GLADDING, McBEAN & CO.**

WORKS  
LINCOLN, CAL.  
--- OFFICE ---  
311-317 CROCKER BLDG., SAN FRANCISCO.

# Steiger Terra Cotta and Pottery Works

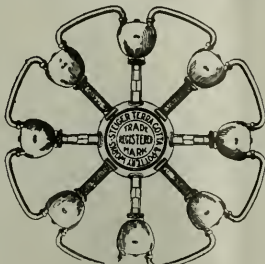

MAIN OFFICE AND YARDS:

City Yard, 18th and Division Streets

Main Office: 729 Mills Building

Phone Douglas 3010

SAN FRANCISCO, CAL.

Factory, South San Francisco  
San Mateo County

1352  
P11 23-24 -

Index to vols 23 and 24, to be found  
on pages 228 and 229 in volume 25.

64067

NOTE—Every city official in California reads Pacific Municipalities.

# Pacific Municipalities

OFFICIAL ORGAN OF THE LEAGUE OF CALIFORNIA MUNICIPALITIES

Entered at Post Office, Santa Clara, Cal., as Second-Class Matter

---

VOL. XXIII TWELFTH YEAR No. 1

---

EDITORS - - - H. A. MASON AND WM. J. LOCKE  
EDITORIAL OFFICE - NINTH FLOOR, PACIFIC BLD'G, SAN FRANCISCO  
PUBLICATION OFFICE, - - - SANTA CLARA, CALIFORNIA

---

## CONTENTS FOR AUGUST, 1910

---

The Latest Ideas in Municipal Charters	5
Some Ideas of Charter Framers	6
Septic Tank Litigation	9
Clean the Street by Air Suction	10
Side Lights on Municipal Accounting	11
False Economy in Fire Hose	15
Good Building Construction	16
The Next Convention	18
Question Box	20
Items of Interest	22
EDITORIALS	27
Program for the Convention	27
Illustrations for Lectures	27
Automobile Fire Engines	27
Bettering the Cities	27
What the Cities Are Doing	28

---

Published Monthly. Yearly Subscription, \$2.00 in Advance. Single Copies, 20 Cents

ADVERTISING RATES ON APPLICATION

Address all Communications to "PACIFIC MUNICIPALITIES" Pacific Building  
San Francisco, California



# LEAGUE OF CALIFORNIA MUNICIPALITIES

Organized 1897

## — OFFICERS —

President	(Mayor of Riverside)	S. C. EVANS
First Vice-President	(City Clerk of Monterey)	W. E. PARKER
Second Vice-President	(Mayor of Berkeley)	BEVERLY L. HODGHEAD
Secretary	H. A. MASON	Assist. Secretary WM. J. LOCKE

## STANDING COMMITTEES

EXECUTIVE—S. C. Evans, President; H. A. Mason, (Sec.) San Francisco; Clinton L. White, Mayor of Sacramento; A. E. Dodson, Councilman, San Diego; H. P. Brainerd, Mayor of Petaluma.  
 LEGISLATIVE—H. L. Partridge, San Jose; M. J. Rogers, Ventura; Hugh R. Osburn, Santa Cruz; James H. Gray, Santa Rosa; S. G. Long, Long Beach.  
 JUDICIARY—C. N. Kirkbride, San Mateo; Perry L. Wood, Pasadena; O. G. Hopkins, Sacramento; W. P. Butcher, Santa Barbara; Wallace Rutherford, Napa.  
 ENGINEERING—W. F. McClure, Berkeley; H. B. Kitchner, Watsonville; Orlin Hudson, Richmond; C. P. Jensen, Fresno; S. J. Van Ornum, Pasadena.

Secretary's Office and Headquarters of the League, - Pacific Building, San Francisco

## INFORMATION BUREAU

The League of California Municipalities maintains, in connection with the Secretary's Office, an Information Bureau where the officials of the municipalities belonging to the League can secure information on all subjects relating to municipal affairs.

## MEMBERSHIP

Alameda	Lompoc	San Buenaventura
Alhambra	Long Beach	San Diego
Anaheim	Los Angeles	San Francisco
Antioch	Los Banos	San Jose
Auburn	Los Gatos	San Leandro
Benicia	Loyalton	San Luis Obispo
Berkeley	Madera	San Mateo
Biggs	Martinez	San Rafael
Bishop	Merced	Santa Ana
Black Diamond	Mill Valley	Santa Barbara
Burlingame	Modesto	Santa Clara
Calistoga	Monterey	Santa Cruz
Chico	Mountain View	Santa Maria
Coalinga	Napa	Santa Monica
Colusa	Nevada City	Santa Paula
Coronado	Newman	Santa Rosa
Corona	Newport Beach	Sausalito
Covina	Oakland	Sebastopol
Crescent City	Oceanside	Selma
East San Jose	Orange	Sierra Madre
Elsinore	Oroville	Sisson
Emeryville	Oxnard	Sonoma
Escondido	Pacific Grove	Sonora
Etna	Palo Alto	South Pasadena
Eureka	Pasadena	South San Francisco
Fairfield	Petaluma	St. Helena
Ferndale	Piedmont	Stockton
Fort Jones	Pinole	Suisun City
Fresno	Placerville	Susanville
Gilroy	Pleasanton	Tehachapi
Glendale	Point Arena	Tulare
Hanford	Pomona	Vacaville
Hayward	Red Bluff	Vallejo
Hercules	Redding	Visalia
Hermosa Beach	Redlands	Watsonville
Huntington Park	Redondo Beach	Whittier
Imperial	Redwood City	Willits
Jackson	Richmond	Winters
Lakeport	Rio Vista	Woodland
Lemoore	Riverside	Yreka
Livermore	Sacramento	
Lodi	San Bernardino	

Every city belonging to the League of California Municipalities is entitled to a free copy of this magazine every month for each of its officials; if not received kindly notify the Secretary.

See that your City is in the above list.

# PACIFIC MUNICIPALITIES

▲ Journal for Progressive Cities

VOL. XXIII

AUGUST 31, 1910

No. 1

## THE LATEST IDEAS IN MUNICIPAL CHARTERS

*(Continued)*

**SAN DIEGO CHARTER.** (In Effect May 3, 1909.) Commission Plan

### No Ward Representation

Legislative and Executive by Council of Five at salary of \$2,000.00 per annum.

Each Councilman is Superintendent of a Department, as follows:

Department of Finance, Ways and Means.

Department of Police, Health and Morals.

Department of Streets and Public Buildings.

Department of Fire and Sewers.

Department of Water.

Mayor, general supervisory powers and right of veto. Is not a member of the Council.

Subordinate officers and clerical force appointed by Council, on recommendation of Department Heads.

Board of Education consists of five members elected at large; no salary.

Park, Cemetery and Library Commissioners appointed by the Mayor; no salary.

**Nominations** non partisan, on petition of 50 electors, names on primary ballot, alphabetically. Candidates taken by placing two highest names upon ballot at general election where only one office is filled, and in case of more than one office to be filled, candidates equal to double the number of offices are taken from those leading on the primary ticket.

All ordinances, especially franchises, must lie over 30 days subject to referendum petition.

**Initiative.** On petition of 15% based on vote of Mayor, Council must pass ordinance within twenty days or call special election. If petition contains 7% but not 15%, must be voted upon at next general election.

**Referendum.** On petition of 7%, within thirty days after passage of ordinance, the ordinance must be repealed by council, or suspended and submitted to vote at special or general election.

**Recall** must be submitted at special election, on 25% petition.

## SOME IDEAS FOR CHARTER FRAMERS

---

An organization in San Francisco has proposed some amendments to the city charter which are worthy of serious consideration by those engaged in preparing charters for other municipalities. We herewith submit a synopsis of the propositions offered, as follows:

### ROTATION OF NAMES ON BALLOT

It is a well known fact that those names placed near the top of the ballot have considerable advantage over those near the bottom. This is particularly true in the case of a long ballot. The average person is more or less nervous in the voting booth anyway, and there are some who get flustered and tired, and finally turn in their ballot without stamping the names of all they intended to vote for. As a result, the man whose family name begins with "A" stands a much better chance of election than he whose family name begins with "W" or "Y," all other things being equal.

As a remedy for this evil it is proposed to rotate the names on the ballot in the proportion that the number of candidates bears to the number of voters. For instance, if there are 10 candidates and 1,000 voters, the names would be differently arranged on every batch of 100 ballots, thus giving all the candidates an equal chance.

Although the unfairness of the present method is more manifest in large cities and on long ballots, it exists in every case, however small the town or short the ballot, and it is something that should be remedied.

### ARGUMENTS ON SAMPLE BALLOT IN INITIATIVE, REFERENDUM AND RECALL

Another amendment suggested is a proposition to require the person or persons petitioning for the adoption of an ordinance under the Initiative, to submit an argument not exceeding a certain number of words in favor of the proposed legislation. Those against the proposition may submit opposing arguments, and both arguments shall be mailed to the voters by the proper officers, as official documents.

On a Recall election it is proposed to require those demanding an official's recall to submit reasons not exceeding 300 words in length, to be printed on the Sample Ballot. On the same ballot and in the same manner, the official sought to be recalled, may justify his course.

### CANDIDATE'S STATEMENT

Another proposed amendment requires candidates to furnish a statement under oath giving information as to their previous experience and qualifications for filling the office. A fee of \$20.00 is charged for the first 100 words and \$10.00 for each additional 100 words. This statement shall then be printed as a public document.

It is generally conceded by those who have given any study to municipal government that the ward system should be abolished.

A councilman elected from a single ward will favor his ward at the expense of the rest of the city; besides, the electors should have a voice in choosing the whole council and not be limited to a vote for one member only. Wards create factions and breed discontent.

It is also conceded that partisanship and national politics should be eliminated



from municipal elections. A man's views on national questions should have no influence on his candidacy for a municipal office, and he should stand on his record as an individual citizen without allegiance to any party or combination.

### ELECTIONS

The system of elections provided by the Berkeley charter is regarded as the best yet devised. It appeals to the non-political or business element of the community and encourages the apathetic or indifferent citizen to exercise all his rights.

The Berkeley charter abolished the party primary, the party convention and all forms of party nominations. Nominations are made by petition only.

The two candidates receiving the highest votes for any one office become the nominees, and the only nominees, for that office. Therefore no person can be finally elected to any office who does not represent the choice of a majority of the voters.

However, the first election is not a mere primary in the sense that a "primary" is generally understood. It is just as effectual and conclusive as the second election because it is provided that in event of any candidate receiving a majority vote thereat, he is thereby elected to the office without being obliged to stand again at the second election.

In fact, the first mayor chosen under the new charter, Mayor Hodghead, was elected at the first election by a majority of over 5000 votes.

### THE COMMISSION SYSTEM

Under the commission plan of municipal government, the legislative and administrative functions are placed in the hands of a small number of men, generally not exceeding five. Each commissioner has complete control of a certain department. In Berkeley they are assigned as follows:

- 1—Department of finance and revenue.
- 2—Department of public health and safety.
- 3—Department of public works.
- 4—Department of public supplies.

In the San Diego charter they are divided as follows:

- 1—Department of fire and sewers.
- 2—Department of finance, ways and means.
- 3—Department of police, health and morals.
- 4—Department of streets and public buildings.
- 5—Department of water.

In most of the modern charters, assignment to the various departments is mutually arranged and agreed upon by the commissioners themselves after election. In the Grand Junction charter, however, each commissioner is elected by the people directly to his particular department. It is claimed by this plan that there is a better chance of electing experts to the various departments.

On the whole, the commission plan of government is merely an application of the business principles used in the management of an industrial corporation. Each commissioner acts as the superintendent of a department and a member of the board of directors. The mayor acts as president of the corporation and presides at the meetings of the board. He has no veto power.

The people stand in the position of stockholders.

After all, why shouldn't the administration of municipal government be conducted on business principles? The commission plan is far more practical and economical than the old cumbersome federal system with its large council spending



most of its time in debating inconsequential matters and splitting hairs. Granting for the sake of argument, that the small council will not be as representative or act as wisely as the large body, the people have their remedy in the initiative, referendum and recall.

#### INITIATIVE, REFERENDUM AND RECALL

No charter would be entitled to be termed "modern" without these provisions.

They simply lay down a method for enabling the people to exercise those inherent rights which have always vested in them. Merely for the sake of convenience and expediency the people select individuals to legislate for them. But there is nothing sacred about a legislator. All the power he exercises is by sufferance of the people he represents. And why shouldn't the people exercise that power direct if they choose? The principle of the Recall is based on the same reasons. If the public engage an official to transact business for them and he prove unsatisfactory, a method should be provided for removing him and selecting another. The Recall provides this method. The right to elect involves the right to remove, and a method should be provided for exercising that right.

#### NOMINATIONS BY PETITION

The general scheme of making nominations by petition is the plan embodied in nearly all the new charters, but there is a lot of room for improvement on the simple method laid down in most cases

It is suggested, for instance, that the number of petitions be reduced, but that petitioners be required to give more evidence of the fitness of the candidate. If a person seeks an appointive position in the Federal Civil Service, he must furnish the verified statements of sponsors who will testify not only as to their acquaintance with the applicant, but also give the reasons why they think he is qualified to fill the position he seeks. Why not follow out this idea in the case of elective offices? Most anyone will sign a petition if there is no trouble or responsibility involved, but if one is asked to stand sponsor for a candidate and give reasons why he should be elected, it becomes a more serious matter, and men will hesitate before stating under oath that a man is well qualified when they know he is absolutely unfit.

#### PUBLICITY OF CANDIDATES

The proposition made by the San Francisco charter revision committee to require candidates to make a verified statement of 300 words regarding their qualifications, is another step in the right direction.

The great majority of the voters have no means of obtaining authentic information as to the fitness of candidates. They must rely almost entirely on the newspapers.

The proposition to require the candidate to make a statement under oath telling briefly, something of his past history, his experience, and his qualifications for filling the office, would furnish the electors first hand information.

This verified statement, together with the statement of his sponsors or some of them, should be made a public document and published in a newspaper for thirty days next preceding the election. All other forms of advertising such as printed cards, banners, newspaper articles, etc., should be forbidden. Such a scheme would place all candidates, rich and poor alike, on an equal footing. Any misrepresentations by the candidate or his sponsors would soon be disclosed by the opposition newspapers and serve as a boomerang to his candidacy.

Some of these ideas could well be adopted into our present State Primary Law and reduce the great financial burden thrust upon a candidate for a state office.

## SEPTIC TANK LITIGATION

---

FROM MUNICIPAL JOURNAL AND ENGINEER, JULY 6

Another chapter is being added to the litigation concerning the Cameron septic tank patent. As stated in our issue of October 27, 1909, the Cameron Septic Tank Company claims that its patent does not expire until October 3, 1916, while it is contended by those against whom the company has brought suit that it expired November 8, 1909. Decision upon this point adverse to the company was rendered on April 20 by Judge McPherson, of the Circuit Court of the Eighth Circuit, which includes the States from Minnesota and Iowa south to New Mexico. The company has appealed to the United States Supreme Court, where the case is now pending.

Meantime, interested cities throughout the country have many of them come to a mutual understanding looking to co-operation toward presenting their view of the case to the Supreme Court to the end that it may sustain this ruling of the Circuit Court.

The difference of opinion as to the date of termination of the patent has been created by the treaty drawn up by the International Congress for the Protection of Industrial property and ratified in 1903 by the United States Senate, and especially by the method of such ratification. This treaty provided that "Patents applied for in the various contracting States by persons admitted to the benefits of the convention under the terms of Articles 2 and 3, shall be independent of the patents obtained for the same invention in other States, whether adhering to the Union or not. This provision shall apply to patents in existence at the time of its being put in force." In ratifying the treaty the Senate omitted that portion which made the treaty apply to patents already in existence. The question, therefore, would appear to be whether this clause so omitted applies in this country. If it does, the Cameron patent does not expire until 1916. If it does not, it expired last November. The same question has been argued in other patent cases. The Circuit Court for the First Circuit held that the clause referred to did not hold in this country; the Circuit Court for the Third Circuit held, in August, 1909, that it does not apply, although one of the judges dissented from this decision, and this opinion has also been held by the Circuit Court for the Southern District of New York, and, finally, in the Decision in the Southern District of Iowa, in the case of the Cameron Septic Tank Company versus Knoxville, Ia., which is the one now pending in the Supreme Court.

---

### INJUNCTION DISSOLVED

The injunction secured by the Cameron Septic Tank Company against the Village of Saratoga Springs, N. Y. has been lifted pending the final decision of the case against the City of Knoxville.

### EXPIRATION OF PATENT

One of the points at issue in the septic tank litigation is this: "Where a patent is taken out in this country on an invention previously patented in England, does the U. S. patent expire with the English patent or run on independently?"

A decision on this question was recently handed down in the case of Maligni

## PACIFIC MUNICIPALITIES

et al. vs. Hill-Wright Elec. Co. reported in 177 Federal Rep. p. 430. District Judge Hazel, referring to the United Shoe Machinery case, says:

"I concur with the reasoning of Judge Putnam, who wrote the opinion, and therefore it follows that the patent in suit has expired because of the expiration of the prior Italian patent for the same invention."

## FINAL DECISION POSTPONED

Miller and White, Attorneys for the cities of the League of California Municipalities, recently received information indicating that it will probably be two years before a final decision is rendered on this question, as shown by the following letter:

BALTIMORE, MD., AUGUST 3, 1910

MESSRS MILLER & WHITE,  
CROCKER BLDG., SAN FRANCISCO, CAL.  
GENTLEMEN:

I have a letter today from the Clerk of the Supreme Court of the United States in which he says that the case of Cameron Septic Tank Co. vs City of Knoxville has been docketed and filed, but that the case will not be reached until March or April of 1912.

Very truly yours,  
STEUART & STEUART

## THREATENING LETTERS

All cities or towns of the league receiving letters threatening suit for infringement of the Cameron patent are requested to send them to Miller and White, Attorneys at Law, Crocker Building, San Francisco. Mr. White is planning to attend the convention of the League at San Diego and explain the exact status of the litigation.

## RECEIPTS AND DISBURSEMENTS

Previously accounted.....	\$ 739 00
April 21—Redondo Beach.....	30 00
May 24—College Park.....	20 00
June 9, Lodi.....	20 00
June 9, Claremont.....	10 00
Total receipts.....	\$ 810 00
Disbursements to date as previously accounted.....	516 55
Balance on hand.....	\$ 293 45



## CLEAN THE STREETS BY AIR SUCTION

FROM THE S. F. EXAMINER

"Isn't it about time for cities to put an end to the present senseless, stupidly criminal method of sweeping streets?"

The streets of American cities are notoriously unkempt, in spite of the fact that millions of dollars are spent by street cleaning departments every year.

The old fashioned rotary street sweepers which roll cumberously along the



streets throwing blinding clouds of germ laden dust into the air are obsolete. Most cities have discarded them.

The men with hand brushes have taken the places of the old machine sweepers; but the men do their work only in a perfunctory way.

The time has arrived when progressive cities should clean the streets by air pressure and air suction. The vacuum cleaners used now in every hotel and in many private homes, should be adapted to the work of cleaning.

The cost would be slight, the streets could be piped, the air exhausted at certain points, and men quietly moving up and down the streets could pick up with their air-exhausting machines every particle of dust, paper and dirt.

While waiting for the streets to be provided with air suction pipes distributed economically throughout our cities, the thing could be done temporarily. A large vehicle with a gasoline or electric air pump moving along the streets, followed by men passing the air exhaust over the street surface, and drawing the dust and dirt into a dust-proof box on the wagon, would diminish the death rate, do away with a public nuisance—and remove far from the city endless billions of disease germs every day.

The dust collected could be burned or hygienically disposed of for fertilizing purposes.

Fortunately, the disappearance of the horse from our streets is a matter of only a few years. The dumping of dirt on the streets by business houses will be stopped. The pavements and the street cleaning will be done by the vacuum process, and this will be followed by regular sprinkling with disinfectants—salt water where this is possible.

It is perfectly safe to say that before the end of this century every big city, its streets, public parks, alleys and crevices, will be kept as clean as the modern hospital.

A beginning should be the installation of vacuum cleaners everywhere."

Commenting on the above article we might add that several inquiries have been made at the league headquarters regarding suction street cleaners. Riverside uses what is known as the Furness cleaner. City officials will confer a favor by sending any information they may have regarding successful machines.



## SIDE-LIGHTS ON MUNICIPAL ACCOUNTING

BY WILLIAM C. DOLGE, C. P. A. MUNICIPAL ACCOUNTANT, FELLOW AMERICAN ASSOCIATION  
OF PUBLIC ACCOUNTANTS

**Editor's Note**—Mr. William Dolge, C. P. A., is a specialist on Municipal Accounting Systems. He was employed in looking after the accounts of the Relief Corporation which distributed many millions of dollars in San Francisco following the great disaster of 1906. He afterwards served as Expert Municipal Accountant of the Board of Supervisors during the administration of Mayor Taylor.

Mr. Dolge will be pleased to answer all inquiries on the subject of Municipal Accounting.

In the opening paragraph of Chapter Six of his most interesting work, Doctor Cleveland says: "The budget is an instrument devised to give to the direct representatives of the people control over administrative officers. Finding its origin in monarchical government it has, where not neglected, become one of the most effective limitations of administrative authority."\* Dr. Cleveland has laid stress

\*Municipal Administration and Accounting, F. A. Cleveland, Longmans, Green & Co., New York and London.



## PACIFIC MUNICIPALITIES

upon the fact that the budget is a most effective limitation of administrative authority where not neglected.

In municipalities of the fifth and sixth class and in most of the smaller cities of the State of California, the control exercised by interested citizens in civic affairs is so great that even with most primitive and insufficient accounting methods, the business affairs of the municipality are attended with reasonable ultimate efficiency of results.

In the larger cities the preparation of a budget upon scientific principles, based upon a truly adequate system of accounting is worthy of the best available professional advice. In the smaller towns, however, any business man competent to handle his own set of books should be able to prepare the budget, or at least criticize it constructively.

It is interesting to note how the struggle to limit expenditures to specific purposes continues, what success it meets, and how ineffective are the regulations generally imposed. Attempts to limit expenditures are made by specifying funds, other than the general fund, in the annual tax levy. When moneys are raised for municipal improvement purposes by means of bond issues, it is customary to specify the purpose and amount to be expended for each kind of improvement. But in the practical work-a-day world, after the taxes have been collected, and after the bond money has been received, nearly every legislative council will make a transfer when deemed necessary, from one fund to another, or from the general fund to a bond fund. Apparently this is in disregard of the ordinance, and literally that is true. In effect, however, the transfers are necessitated by the need of the moment and because the financial program is not sufficiently flexible to adjust itself to conditions as they may arise.

The particular function of the budget is to specify in great detail the proposed expenditures for a given fiscal year. If carefully prepared and due allowance is made for an emergency (contingent) fund, there will be no occasion to violate either the letter or the spirit of the laws or ordinances. If not so carefully prepared, it is still possible to enact an amending ordinance, in conformity with the law, thus giving due notice of impending changes to the interested citizens.

The importance of an estimate of proposed expenditures in budget form can not be exaggerated for municipalities conducting public utilities of any character. Water distributing systems, water works, electric light and power plants, gas works, water fronts, in short any functions of the municipality of a business character, wherein there are revenues for service and expenditures on account of maintenance of that service, can best be controlled by the annual budget. As a matter of fact, something of this nature, whether characterized by the name of budget or not, is done wherever such utilities exist. Usually, of course, no formal reports are filed; the discussion is limited to the heads of the undertakings mentioned and the Chairman of the respective committees of the legislative branch of the government. The budget enacted as an ordinance would be the means of bringing the entire subject before the citizens.

## THE ASSESSMENT ROLL

The foundation of the collection of revenues from taxes for the maintenance of any municipal government is the assessment roll. Where no assessor is specifically provided by law or charter, the town clerk performs the duties. The first assessment roll is usually nothing more or less than a transcript of the County Assessor's roll in so far as it relates to the particular municipality in question. Upon matters of valuation of property, this may be considered desirable, but it is

obvious that items may escape the County Assessor that should be noted by an efficient City Assessor. Strange as it may seem, it is not uncommon to find an assessment roll made up in alphabetical order of tax papers, instead of in the order of the property as it appears upon maps of accepted surveys by tract, block, and lot number. The alphabetical order makes it difficult to prove the inclusion of all property and invariably results in unequal valuations of contiguous properties. It is true that the block and lot method of entering the assessment roll makes necessary an index, and the issue of a tax bill for each separate piece of property. This is not a fault but a virtue of the method, because it reduces the tax collection accounting to a unit basis. The unit being one parcel, whether large or small, whether a part of a tract, a block or a part of a block, or a single lot or a part of a lot.

An assessment roll prepared by the method reduces the labors of the Board of Equalization to a minimum, and gives every property owner opportunity to compare the assessor's valuation of his property with that of his neighbor.

After the Board of Equalization has completed its duties, and the assessment roll has been modified in conformity with the orders of the Board of Equalization, the roll should be checked for its arithmetical accuracy by parties other than either the Assessor or the Tax Collector. The very simplicity of the assessment roll computation makes errors possible and opens wide the door for the honest Tax Collector or Tax Collector's deputy.

The verification of the roll, or "experting of the roll," as it is usually called, should be done by thoroughly competent authority, by some one who will do more than merely foot the columns. A qualified man will examine valuations of kindred properties, and will satisfy himself that the deductions for mortgages and other liens are properly assessed to the holders thereof. It is an important fact that the errors found usually aggregate considerably more than the bill for services of the accountant doing the work.

#### COLLECTION OF TAXES

The general laws provide that in the place of the Marshal, the Treasurer may be made the Tax Collector. The writer has often wondered what was in the minds of the framers of the Municipal Corporation Bill when they combined the offices of Marshal and Tax Collector. The qualities that make a man a good Marshal, a police officer, would seem to make him a poor Tax Collector. Tax collection is a work of a purely clerical nature consisting of the issuance of tax bills, receiving money from tax payers, depositing the collection with the Treasurer, making up the delinquent tax roll, publishing the tax sale list, conducting the sale, and making his final settlement with the clerk. Usually the Treasurer's duties as treasurer, are purely nominal, inasmuch as they consist only of depositing the city revenues in bank, and payment of properly authorized warrants. The Treasurer's compensation is based upon his responsibility as a fiduciary officer and is therefore much higher comparatively than that of the Marshal. Usually the Treasurer is a man of clerical experience, at least sufficient to take proper care of the accounting required in connection with the collection of taxes.

It would be an exaggeration to say that there are as many different forms of tax bills in use as there are municipalities and counties in the State of California, but it is not an exaggeration to say that there are, at least, half as many. The size varies from a small slip of paper not larger than an ordinary receipt blank to that of a sheet the size of an Australian ballot. The adoption of a uniform tax bill for all of the municipalities and counties does not need to await legislative action. Co-

operation with the printers and stationers, who specialize on municipal work, and with county officials will assist in reducing stationery bills and minimizing the labor of officials as well as of tax papers. Where it is desired to favor the local newspaper printing plant with a printing job, an approved form should be submitted and the local printer be compelled to follow that form. There was recently presented to the writer a tax bill from one of the northern counties from which it was absolutely impossible to determine any material fact, except that the bill covered the fiscal year 1909-1910 and that the amount of the taxes was \$167.80. The description of the property was incomplete, the tax bill did not show the valuation of the property, nor did it give any inkling of the rate for state, county, school, road, or other purposes. The tax bill should convey complete information to the tax payer. In addition to describing his property and showing the valuation, the tax bill should show the basis of the valuation, whether on full value, 70% of the value, two-thirds of the value, or 50% of the value. It should show the total tax rate and it should show the composition of the total tax rate, giving the rate for each separate purpose. It would be better if the tax bill showed also the total amount of the assessment roll and of the tax levy. All this information is available, or should be available, long before it becomes necessary to print the tax bills, and a proper form is no more expensive than one improperly prepared. The tax payer then has an opportunity to compute his own tax bill and the computations made by the Assessor are checked by those most vitally interested.

Where tax bills are numbered in conformity with the assessment roll (and no other manner of numbering should be permitted) the preparation of the delinquent tax roll becomes merely a matter of copying the unpaid items from the assessment and confirming this transcript with the unpaid bills remaining in the tax bill books. It is a good plan to provide two stubs for the tax bill, one of which is filed with the Clerk when the money collected thereon is deposited with the Treasurer. In this manner the records are safeguarded from total destruction. Many Tax Collectors ignore the constitutional provision with reference to making immediate deposits with the Treasurer of all moneys in their hands. The Municipal Corporation Bill provides for settlements, but this has reference to the adjustment of the accounts and does not mean that Tax Collectors and other officials have the right to retain moneys in their possession for a period of thirty days or thereabout. The importance of the three separate settlements with the Clerk and the Treasurer by the Tax Collector are overlooked frequently. The first settlement is presumed to take place upon the day that the taxes become delinquent. The Tax Collector is charged with the total amount of the taxes to be collected, and is credited with deposits made with the Treasurer. The balance of the account should equal the delinquent tax roll. If the delinquent roll is found to be less than this balance, it is apparent that an insufficient amount has been deposited with the Treasurer, which may be due to errors in collections for which the Tax Collector is responsible.

Starting with delinquent roll at the beginning of the second period and adding thereto the percentage for penalty, the Tax Collector takes credit for the deposits in the city treasury and makes settlement with the Clerk by taking further credit for the difference of this new account, which represents uncollected taxes plus the penalty on each item. With this balance at the beginning of the third period and adding the cost of publication (usually 50 cents a parcel) the Tax Collector is charged. He is credited with the deposits in the city treasury and the sale of property to the city, the last item being the taxes, plus penalty, plus cost of publication on each parcel that was not bid in at the time of the tax sale. With this final credit his accounts should balance.

NOTE—Next month I shall take up the asset value of Property Sold the City for Taxes, the Redemption of Property Sold for Taxes, and Licenses.

Licenses will be taken up first from the standpoint of Revenues, and how they may be increased; secondly the collection and accounting of licenses.



## FALSE ECONOMY IN FIRE HOSE

The methods of electing city officials, whose duty it is to receive and pass upon the many bids for supplies which are continually required for use in the various departments of a city government, is largely the reason why so much money is practically wasted throughout the country. There is doubtless, in the majority of cases—a conscientious desire on the part of the individual members of Boards of City Trustees, Councilmen, Supervisors, and members of commissions, to secure each for his city, the best and cheapest article offered—but unfortunately the question of cheapness in price, far outweighs all other considerations, as is often the case, for instance, in the purchase of Fire Hose, and this is due principally to the deplorable fact that men are often elected to political office, not on account of their fitness or experience, but because they represent some political party or faction, and will see to it that contracts are awarded to their friends and political supporters.

The fire department of any city or town is one of the most important branches of Municipal Government and is one of vital interest to all taxpayers, property owners and business houses. This department should be the very last place to sacrifice efficiency to so-called economy.

The phenomenal and continued advance of crude rubber, cotton, etc., within the past year has compelled the manufacturers of fire hose to adopt either one of these two measures; to maintain the quality and raise the price, or to continue lowering the quality to such an extent that the price is not advanced, notwithstanding the increased cost of the crude material and labor. Crude rubber, such as all reputable manufacturers should use in the construction of the tubes for their fire hose is now quoted at more than \$3.00 per pound, and everyone knows that in order to withstand deterioration from age, abuse and hard usage, no shoddy material or reclaimed rubber should be used. Based on present market conditions (and they seem to be conditions that bespeak permanence) no first class two and one-half inch fire hose can be made or sold for less than \$1.00 per linear foot. Hose is regularly offered to city officials at ridiculous prices, sometimes as low as 65 cents and even less, and it is possible that hose offered at these prices can be made to appear equally as good as other brands quoted at \$1.00 or more, but *time* is the factor which determines the *real value* of fire hose and it is the worst kind of *false economy* to buy fire hose because it is *cheap in price*. It should always be borne in mind that bargain sales are never offered on staple materials and it is impossible to secure greater value from any hose than the price paid for it; therefore fire hose at a dollar or more which will render good active service for a period of from ten to twenty years is far cheaper than a sixty-five cent hose, whose service is rarely greater than a year or two.

Insurance becomes more costly where the equipment of a fire department mainly consists of a cheap quality of fire hose and out of date apparatus.

The selection of fire hose should *never* be made from political or friendly considerations, but only from the standpoint of quality and efficiency. The reputation of the manufacturer and the actual record of the brands of hose offered in other cities, are the only safe and dependable testimonials to guide officials in the proper selection of hose.

In this day of rapid advancement, the progress of a city or town can be correctly judged by the purchases of fire hose and other equipment. Let us hope to



see the passing of cheap (?) fire hose and the doing away of the purchasing of this form of commodity, from political and friendly considerations, instead of looking for quality and efficiency, backed by reliable testimonials and the reputation of reliable manufacturers.



## GOOD BUILDING CONSTRUCTION

---

BY FRED J. RICKON, C. E., FROM THE "ARCHITECT AND ENGINEER" OF CALIFORNIA

Reinforced concrete in experienced hands is a safe and highly satisfactory building material. Improperly handled, the same class of construction is dangerous, but no more so than steel or brick. We hear of failures in all classes of building, due invariably to incompetent supervision, but more publicity is given concrete troubles because it is only in the last few years that this type of construction has become general. We find that the enemies of concrete are invariably responsible for the distorted accounts of alleged reinforced concrete failures. However, I do not believe in shielding poor construction, even though it may hurt the industry. The proper kind of publicity should and will act as a check and a preventative of bad work, be it concrete, brick or steel.

The Pacific Coast seems to be especially fortunate in having experienced men to design and superintend its great buildings. The contractors, too, are, as a whole, men of experience and reliability and the result is we have had few, if any, failures.

Although the practical advantages of reinforced concrete were demonstrated long before theoretical analysis of its properties was entered into, there is still much hesitancy over its use, due, no doubt, to the want of an understanding of its true properties. However, tests, experiments and researches have been made as years have gone by, until today, formulas have been established whereby the architect and engineer can calculate to a nicety the results that will be attained under a given proposition.

The use of reinforced concrete has become so general and its importance has grown to such an extent that no architect, civil engineer or builder can afford to be without a thorough knowledge of its properties and applications; for the time is fast coming when this type of construction will be more extensively used than all other types combined, and the architect, engineer or contractor who is not prepared to undertake the work will be in want of something to do. There is hardly anyone who will not concede that both concrete and steel are unexcelled building materials, and a proper combination of the two materials which makes reinforced concrete, must necessarily make it all that can be desired.

The ease with which reinforced concrete may be applied to almost any form of construction, and at the same time the necessity for properly reinforcing so as to counteract the effect of tensile strains and stresses, really divides the work into two heads—the architectural, and the engineering. Therefore, in works of importance it is desirable that the drawings be carefully gone over by an engineer of practical experience in this method of construction, for, while there is no method of construction under equal conditions that is as economical or more trustworthy, in order to secure a successful outcome, the work must be subjected to a

rigid inspection at all times, and the contractor is held responsible to the obtaining of certain specified test results. The most active inspection will not always prevent poor workmanship or faulty construction, either of which can destroy the strength of structures made of the best materials. The proportion made of the concrete may not be in all parts according to the specifications; good judgment may not have been exercised in gauging the quantity of water. If too much water is added, the strength of the concrete, and especially its co-efficient elasticity, will be decreased. If too little water be added, the adhesion of the concrete to the reinforcing metal will not be sufficient.



A NEW OAKLAND FIRE HOUSE

Great care must be exercised in the inspection of materials that they be up to the standard required. All cement should be tested on the ground to ascertain its tensile and compressive strength, and to establish the evenness in grade, and no cement should be used which shows disintegration in the boiling test. The sand must be carefully inspected to see that it is clean and free from impurities, and not too fine—not over 25 per cent of its bulk should pass a 30-mesh sieve. The crushed rock must be hard and free from shale or decomposed particles, and not

too coarse—all should pass a three-fourth inch sieve. The steel, if not twisted, shall be tested to ascertain if its quality is correct. If twisted, the twist should be measured to ascertain if it has the correct number of turns per foot, according to size. Hard, or what is termed "high carbon steel," should not be used in tensile work as it is liable to snap when loaded. Quite as important as the quality of the material is the placing of the same.

In order to secure the intended action of the steel, care must be exercised that it be placed on the lines of the stresses created in tension, shear or compression; otherwise its effectiveness will be lost in whatever degree it is misplaced. The misplacement of the reinforcing metal changes the construction from reinforced concrete to simply a protection of steel by concrete, and, unless the steel be excessively heavy, failure is sure to result. Care must also be taken with the concrete that the proper percentages of its component parts are properly massed and mixed, that the proper amount of clean water is incorporated. Great care must also be exercised in the placing and tamping the concrete in the forms in order to secure complete density throughout the entire mass and perfect contact over the entire surface of the reinforcing metal.



## THE NEXT CONVENTION

---

The thirteenth annual convention of the League of California Municipalities promises to be the largest yet held in the history of the organization, in point of attendance. Inquiries are coming in from all over the State asking about the date and facilities for getting to San Diego.

The convention will open on Tuesday, November 16th and run to the 19th inclusive. This time was fixed upon after a conference between the officers of the League and the Mayor and City Council of San Diego. The new Grant Hotel which, when completed will be one of the finest hostelries in Southern California, has been selected as the official headquarters and place of meeting. The Southern Pacific Company and the Santa Fe Company have both sent word that regular convention rates of one and a third fare for the round trip will be granted to all those attending the convention. Delegates and those who accompany them must secure a receipt from the agent upon purchasing their tickets.

### NEW FEATURES

The State Board of Health and California Public Health Association will meet with the League as they did a year ago at Santa Cruz. In accordance with a resolution adopted at the last convention there will be a department of Public Health, in addition to the other departments of Attorneys, Clerks and Engineers, and a special effort will be made to secure a large attendance of municipal health officers.

The plan inaugurated at the Santa Cruz convention of having the various departments meet separately during the morning sessions, will be followed as far as possible, subject to the modifications that future developments may indicate as being more practical or beneficial.

In order to make the most of the short time we are together, Mayor Evans says he will require each speaker to adhere closely to the subject under discussion and we hope the president of each department will follow his example. It would



be better too, if the meetings were called to order at 8:30 or 9 A. M. sharp. The entire day should be devoted to work, and the evenings to such entertainment as the officials of San Diego may be kind enough to provide. In other words, we should follow a well known children's maxim which says "Work while you work and play while you play."

Among the various speakers, will be a talk by Councilman A. E. Dodson, who will tell how the Commission form of government works in San Diego.

Mr. William Dolge C. P. A., Expert Municipal Accountant, who was the official expert employed by the San Francisco Board of Supervisors under the Taylor administration, will deliver a talk on Municipal Accounting, illustrated with a stereoptican or mirror scope.

Mr. J. H. Reed, the Tree Warden of Riverside will be asked to tell how he succeeded in making Riverside so famous for its beautiful street trees. This talk will also be illustrated with pictures thrown on a screen.

The State Board of Health have been taking pictures all over the State of the bad sanitary conditions which exist in some places. Many of these pictures will be used to illustrate a talk by some representative of the board, and model ordinances for the correction of abuses will be submitted to the delegates with the request that they be adopted and enforced in the various municipalities they represent.

The question of constructing good pavements is an ever-present one. At the Santa Cruz convention the engineers declared that oiled macadam was the best pavement for streets and roads in California. Acting on their opinion, many miles of oiled macadam streets have been built in the State during the past year. Pictures of the best work in this line will be thrown on the canvas to assist the speaker who will deliver the formal talk on this subject.

Mr. William K. White of Miller and White, the attorneys for the League in the septic tank litigation, will be on the program.

Each speaker, including those to deliver the formal talks, will be asked to condense their remarks, in order that plenty of time may be had for cross-fire questions.

Another feature of the convention will be an exhibition of municipal machinery and supplies. Many supply houses have expressed a desire to attend the convention and show their wares, and it was thought desirable to try the experiment of issuing a general invitation to all those selling machinery or supplies to municipalities. Space will be provided for all those who care to exhibit, where they may demonstrate the relative merits of their respective articles, without interfering with the proceedings of the convention.

Let us hope that every incorporated municipality in California will send at least one representative to San Diego. If your town is newly incorporated or you are unlearned in the administration of municipal affairs, you owe it to the people who elected you to attend this convention and learn from those who have had far more experience. On the other hand those who have had lots of experience in this work are under a moral obligation to attend the convention and give their fellow citizens from other parts of the state the benefit of their knowledge. Many thousands of dollars have been wasted through ignorance, inexcusable ignorance at that. Therefore we ask the trustees and councilmen of all the municipalities in California to vote the expenses of at least one deligate to our next convention, and although a stenographic report of the proceedings will thereafter be published in PACIFIC MUNICIPALITIES, there is no knowledge like the knowledge gained by "word of mouth." If you will consult the list of delegates who attended the meeting at Santa Cruz a year ago, you will find that it represents every one of the most progressive and prosperous cities in California, who never fail to send delegates.



## QUESTION BOX

---

CITY OFFICIALS ARE INVITED TO MAKE FREE USE OF THIS DEPARTMENT. ALL QUESTIONS SUBMITTED WILL BE ANSWERED BY MAIL, AND THOSE OF GENERAL INTEREST WILL AFTERWARDS BE PUBLISHED IN THESE COLUMNS. THE SECRETARIES HAVE AT THEIR COMMAND ONE OF THE FINEST LAW LIBRARIES IN THE STATE.

Q.—Please send us the gist of an ordinance regulating the keeping of chickens within the city limits. C.

ANS.—DEAR SIR:

We send you enclosed copies of the San Francisco and Los Angeles Ordinances on this question. We are told that Pasadena has a good ordinance also, and suggest that you write for a copy.

Q.—In cities of the sixth class can the assessor and tax collector perform their duties directly under the general laws or must ordinances be passed providing for mode of procedure? T.

ANS.—Assessor may perform duties directly under Sub. 877 of the Municipal Corporations Bill. Under Sub. 871 an ordinance should be passed covering in particular the duties of the tax collector.

Q.—Can we provide by ordinance a method for enforcing the construction of cement sidewalks? B.

ANS.—The construction of sidewalks can only be enforced under the Sidewalk Act of March 6th, 1909, numbered Act 3935.

Q. 1.—Has a solicitor going from house to house any more rights than a peddler?

2.—Has a farmer the right to sell his own productions without paying a city license tax? S.

ANS. 1.—It depends upon the provisions of your ordinance and the nature of the solicitor's business. If he is soliciting for a business house in another state, it is construed to be a violation of the interstate commerce law to require him to pay a license. Read the article entitled "Municipal Licenses," by City Attorney F. D. Stringham of Berkeley, published in the June number.

2.—Farmers and manufacturers have the right to sell their own products without paying a license tax.

Q.—Please give us information as to the rates charged for natural gas; our city is supplied with natural gas only.

SANTA MARIA.

ANS.—Your city is probably the only one in the state using natural gas only. In order to establish the rates to be charged you would have to enlist the services of an engineer, preferably one who knows something about gas plants, in order to ascertain the approximate value of the plant. We are informed that Stockton, Sacramento and Ventura have or have had some natural gas; you might secure further information from those cities.

Q.—Must a freeholder have been a qualified elector for five continuous years immediately preceding the freeholder's election? M.

ANS.—Yes; see *People vs. Hecht* 105 Cal. 625.

Q.—Is there any statutory provision relating to a fiscal year for municipalities? D.

ANS.—No.

Q.—A lady living in the country wishes to peddle ice cream inside the town limits and claims that she is exempted from paying the usual license under the provisions marked in the enclosed copy of our ordinance, as she makes the ice cream from the products of her own farm. How would you construe the ordinance? Is there anything in the general law covering such a case aside from the provision mentioned which I understand was made to agree with the state law? L.

ANS.—Replying to your inquiry of August 25th will say that according to the provisions of Subdivision 5 of Section 3 of your ordinance No. 33, it appears that the manufacturers of a dairy or poultry farm are exempt, and it could be construed that ice cream is a manufacture of a dairy and poultry farm.

The ordinance is ambiguous and uncertain as to its meaning; therefore it would be better to give her the benefit of the doubt. You can amend the ordinance and make her liable for a licence tax providing she is going to make a business of selling ice cream. If she intends to sell it only for one or two special occasions, the courts might not consider that she was engaged in the business. Section 3382 of the Political Code has been superceded by Paragraph 10, Sub. 862 of Act 2348, which authorizes cities of the sixth class to license all kinds of business, for regulation and revenue.

Q.—Will you kindly tell me if an election day or primary election day is a legal holiday, and is it lawful to transact business on that day, for instance, the board of equalization fixing the tax rate? S.

ANS.—Replying to your inquiry of August 24th will say that a primary election day is now a legal holiday and if your board sat as a board of equalization on that day, there is some question about the legality of any changes you might have made in the assessment roll, providing you raised any of the assessments on that day.

Q. 1.—After the Assessor has turned in the Assessment Roll, has the board of trustees the right to amend it to the extent of making the description more explicit?

2.—What is the latest time within which the trustees must finish equalizing the taxes?

3.—How much notice must be given of the meeting of the board of equalization?

ANS. 1.—Yes.

2.—They must sit from day to day until finished with the work.

3.—The general laws do not require any published notice, but the tax ordinances of most towns call for the publication of at least a week's notice.

## ITEMS OF INTEREST.

**Seventy-two Cities Now Under the Commission Form of Government**—According to a recent count, 72 American cities have followed in the footsteps of Galveston, and have adopted a commission form of government. As we have previously explained, a small commission replaces the city council or board of aldermen, and, in most cases, the office of mayor also is abolished. The commission becomes not only the legislative but the executive head of the municipality. The members of the commission are presumed to be elected as a non-partisan board of directors to run the business of the city.

The remarkably rapid spread of this new form of city government indicates clearly the existing popular disgust with present political conditions in most cities. The ward politician appears destined to become an extinct species in the very near future. Not even the natural conservatism of the majority of mankind is likely to prevent a very rapid change in the prevailing form of city government, for the belief is deep seated that no change can possibly be for the worse.

The ultimate success of the commission form of government rests upon the character of the men selected as commissioners. It is our belief however, that the task of selecting capable and honest men is greatly simplified by reducing the number to be selected. Also it is apparent that one honest commissioner has far greater power for good when he is not lost in a crowd, but stands conspicuously among a few who may be opposing him. These and other reasons strongly commend the commission form of city government, but the strongest commendation comes from the invariable success that has thus far followed its adoption.

**Exhibits at Conventions.**—MUNICIPAL JOURNAL AND ENGINEER.—President Mason, in his annual address before the American Water Works Association, stated that he considered the personal acquaintance made and the information obtained by "buttonholing" experts at conventions to be of even more value than the papers. Still another source of benefit at many conventions is the exhibition of appliances and materials from which all, but especially the younger members, may derive invaluable information concerning the practical side of their profession. The Water Works Associations especially seem to find such exhibits desirable. At the convention of the American Water Works Association last week, there was shown the latest ideas in meters, valves, sprinkling cart connections, meter boxes, pipe locators, aquaphones, and various other contrivances, which gave a wider and better knowledge of these than any amount of reading and agents' descriptions could have done.

The exhibit committee of the New England Water Works Association is this year introducing a new feature, space being provided for the display of special tools or devices invented by superintendents or managers of water works plants, also for drawings or photographs of machines, emergency outfits, tools or testing apparatus, plans of shops, supply storehouses, etc. This seems to us an excellent idea and one calculated to bring to the attention of members good devices which they might otherwise never hear of, because of the idea of their inventors that they are not worth a regular paper, or of the hesitation or difficulty which many well-informed men find in expressing their ideas on paper.

**Graft Unpopular.**—The city of Los Angeles has just completed a coping and railing for the Main street bridge which cost the city about half the amount



of the bid submitted by the lowest bidder and which was completed in about half the time.

The lowest bid for the work was \$6638. The city engineer, under an honest city administration, knew that the bid was excessive and involved a very comfortable rake off. He asked to do the work himself, and putting a bridge engineer in charge, hired a foreman, paying the foreman at the rate of \$100 a month, with a bonus on all he saved in time and material. The bonus earned by the foreman was \$299. The work completed cost the city \$3859.15, which includes the bonus, and is a saving of \$2778.35 over the lowest bid.

Non-partisan and honest city government pays and voters are learning that it comes through smiting the machine and putting the political boss out of business.

Municipal work, done by honest and efficient city government, is being demonstrated all over the country as entirely feasible. Honesty and efficiency as a municipal asset is coming more and more, to be appreciated.

Partisanship and grafting party politicians who have had their political debts to pay off out of public graft in our American cities have been a prolific source of municipal waste as well as corruption.

**Treating Barred.**—ROCKFORD (Ill.), May 3.—The City Council passed a new liquor ordinance last night, and on May 13th saloons will be in operation. Rockford has been "dry" for the last year.

An agreement not to treat or allow treating is required. Free lunch, music and games of chance are barred. No brewer, distiller, employe or stockholder of a brewery or distillery will be granted a permit. The barroom must be a single room without connection with others and without tables, chairs or dumbwaiter. Two stools may be placed behind the bar for the use of the proprietor and bartender.

**Must Pay License.**—NAPA, May 10.—Judge Gesford yesterday afternoon decided that the physicians of St. Helena must pay the license tax imposed by the Town Trustees of that place. The case was that of Dr. Osborne, brought to test the constitutionality of the ordinance.

**Advertise for Mayor.** Berlin, Ger.—Following the German theory that the best way to fill a municipal office is to hire the best available expert in the particular line of work to be done, the city of Magdeburg, by the President of its Council, is advertising conspicuously in prominent German newspapers:

"The place of Mayor of Madgeburg is vacant. The salary is 21,000 marks (\$5,250) a year, including the rental of a dwelling in the City Hall. Besides the salary the incumbent will receive \$4,900 marks (\$1,000) for his official expenses. Candidates should apply before September 1."

The Magdeburg case attracts special attention, as it is the first large city to advertise in filling so important an office. The retiring Mayor, Dr. Lentz, was lately promoted to be Prussian Minister of Finance.

**OAKLAND, CAL.**—As a result of the election, July 6, Oakland is assured of a new charter. The Citizens' Progressive Party, which won that election, in its before-election platform advocated the following salient provisions:

A commission form of government with the Mayor elected by the people and not by the commission.

The initiative and referendum and recall with such fair percentages as will most facilitate their use for the control of franchises and for effective self-government by the people.

The acquisition, ownership and operation of public utilities by the city.



## PACIFIC MUNICIPALITIES

The municipal ownership and control of water supply, waterfront and wharves, and the disposal of public franchises only on a basis which will insure to the city a just return on the value of the privilege granted.

The exercise of civil service reform in all municipal departments.

The employment of Oakland citizens only on municipal work, the wages to be based upon the standard governing private employers.

The short ballot in the interest of intelligent choice by the electorate.

The holding of direct primary non-partisan elections, the rotation of names on the ballots at all elections and the abolition of ward lines.

The borough system in the event of consolidation with adjoining cities and a consolidated city and county government.

**Against Public Cup.** St. Paul, Minn.—Placards warning citizens against public drinking cups have been posted in hotels, post offices, railway stations, court houses, city and town halls, and other places where the public cup is used. The placards were sent out by the State Board of Health, H. M. Bracken, Secretary, to county and municipal Health Officers, who were requested to post them where they would do the most good. The warning follows:

Caution! Dangerous diseases such as diphtheria, tuberculosis, etc., are frequently communicated by the use of public drinking cups.

Protect yourself and those dependent on you

Provide yourself with an individual cup and thus avoid the possibilities of contamination.

By order of the State Board of Health.

H. M. BRACKEN, Secretary.

**Bonds Election—Sufficiency of Proposition.** *Neacy v. City of Milwaukee et al.*—A proposition submitted to the electors of a city of the first class for the issuance of \$500,000 of bonds for the construction and maintenance of a lighting plant does not with sufficient clearness declare what specific part may be expended in construction alone, and an adoption of the proposition, while the voters knew of the report of the city engineer that a plant could be constructed for \$250,000, is invalid, and the city may not issue bonds nor take any other steps based on such adoption.—Supreme Court of Wisconsin, 126 N. W. R. 8.

It is announced that the city of Los Angeles will have 120,000 horse power of electric energy from the hydraulic power in connection with the Owens river aqueduct. The tremendous volume of that amount of power is well illustrated by the fact that it is a hundred times as much as the maximum amount distributed by the Riverside electric plant; and that is the biggest municipal power plant in the state. Los Angeles will have enough power to supply 100 cities like Riverside when its aqueduct is completed and power plants installed to utilize its water power. At \$3 per horse power per month this is worth \$360,000 per month, which is certainly going some.

**Contracts—Letting to Lowest Bidder.** *Fourmy et al v. Town of Franklin et al.*—Under act of 1902, paving contracts must be let to the lowest responsible bidder who can give satisfactory security; and where a Town Council awards such a contract to one of the bidders, ignoring two lower bids, without even plausible reasons, the award will be set aside as an abuse of the discretion vested in the council.—Supreme court of Louisiana. 52 S. R. 249.

**Paying for Street Improvements.** San Francisco, August 17.—In order to

hasten street and other improvements in neighborhoods where property owners can not see their way clear to pay assessments under the present method of the Merchants' Association has proposed a plan providing for ten year bonds which shall become a first lien upon property involved.

Most of the extensive improvements in Seattle have been made through a system of five and ten-year bonds, and as the scheme is allowable under the California laws, it is planned to have the charter amended to permit such work to be paid by short-term bonds. As the plan works in Seattle, the contractors must accept the bonds, but there is no difficulty in disposing of them.

**Boston's New Smoke Law.** Boston, Mass., has suffered considerable annoyance in the past from the effects of smoke. The defacement of her public buildings and private residences has been a reflection upon the city. In addition to this the destructive effects upon the foliage, and all kinds of vegetation, as well as the effect upon the health and comfort of her citizens, called loudly for action. No one has any more right to contaminate the air we breathe than he has to defile the water we drink. The smoke law, if rigidly enforced, will reduce this nuisance to a point where its injurious effects will be practically eliminated.

In Chicago, statistics were recently compiled which showed that there was a yearly decrease in the mortality rate due to acute contagious diseases of 13 for each 100,000 of population; a decrease of 12 from diseases due to impure water; a decrease of 11 from causes due to impure food, while the diseases resulting from impure air, such as pneumonia, bronchitis, and consumption, showed an increase of about 22 for each 100,000 of population. No doubt there are other factors which are perhaps as potent as smoke in the defilement of the atmosphere, but if we can eliminate even one of the contaminating influences, it will be a step in the right direction.

The territory covered by the new Smoke Law Act includes not only Boston, but also that part of Boston Harbor lying westerly of a line drawn from the southeastern part of Deer Island to a northeastern point of Long Island, and the contiguous cities of Cambridge, Somerville, Everett, Chelsea, and the town of Brookline. Under this law both the railroads and public service corporations are included, as well as all other users of smoke-stacks. The consumers of coal have been allowed three years in which to prepare themselves for the final provisions of the law, which take effect in 1913. This will give all subject to these provisions ample time in which to make alterations in their plants and such changes as may be necessary in order to comply with the law. Already there are evidences that the smoke nuisance in Boston is going to be considerably abated, even in the first month of the law's operation.

**Sprinkling Oil on Macadam Streets for First Time.** Lock Haven, Pa.—The tank car of oil recently ordered from the Atlantic Refining Company has arrived, and the macadam roads in the city are being oiled with the new sprinkler purchased for the purpose. This is the first time Lock Haven has tried the oil method of treating roads. As it has proven very successful at other places, it is hoped there will be a big improvement in the condition of the roads here.

**Bonds of Popular Subscription.** Recently Philadelphia issued \$5,000,000 of 4 per cent 30 year bonds, but instead of selling them to a syndicate or giving a syndicate a one-sided option on them, it offered them direct to the citizens at par, the result was surprising. The subscriptions from the people aggregated over \$8,000,000 or \$3,000,000 more than was needed, and in addition to that the banks

asked for \$1,500,000. Philadelphia is one of the worst governed cities in the country. Its financing has been very bad. At times it has been very difficult to sell that city's bonds. Contrast this episode with the way Los Angeles is knocked about from pillar to post on the sale of the 4½ per cent 40 year bonds, through a syndicate that has us neatly sewed up in a bag.

**Terra Cotta House With Glass Dome.** One of the largest fireproof country homes ever built is now nearing completion at New Brunswick, N. J. The owner, Watson Whittlesey, is erecting it in the California Mission style with a center patio, or court, containing fountain and palm garden.

The house stands on a heavily wooded plot of ground overlooking the Raritan river. Walls, floors and partitions are of hollow terra cotta blocks, the exterior being finished in white stucco. All the living-rooms are on the main floor surrounding the court. On this level are eight large rooms, with two baths and a butler's pantry and kitchen.

Above the living-rooms, over-looking the palm garden and fountain, is a gallery surmounted with a glass dome thirty feet in diameter by thirty feet high. This dome is built entirely of wired glass. Around its base are fifty electric lights for illuminating the court and gallery. Just off the gallery, over the porch, is the owner's study, a room twenty-six feet long and eighteen feet wide, at one end of which is a large fire-proof storage vault of steel and hollow tile.

Under the main floor are a billiard room and a "den." Altogether, the house will contain fifteen rooms in addition to the gallery and court. None of the rooms will be papered; the hollow tile walls have a sand finish, so that they can be painted in any color.

The cost of a fire-proof home is estimated as only 10 per cent greater than the cost of a frame building of the same size and style. The saving comes in the form of lower insurance rates and fewer repairs. The tile walls being non-conductors of heat, make the house warmer in winter and cooler in summer than a frame house. This is responsible for a considerable saving in fuel bills.—Architect and Enquirer of California.

**Stand by Your Town.** Robert J. Burdett, in a recent address on "What a Man Owes to His Town," said: "He owes this duty to himself and to the town to own a part of it. Ever so small a lot if he can't own a big one. A forty foot front if he can do no better. But he should own a part of the town. That gives him a stake in it.

"The man who owns a home in the town never calls his town—it. When he speaks of it, whether it be in London or Tail Holt, New York or Waikiki. He says we—our town, and he has a perfect right to. He is a stockholder and a partner.

"More than that, when he owns a piece of ground, farm or town lot, he has a stake in the earth. He is a citizen of the universe. His property extends from the brimstone out to the stars. Even now they are disputing the right of an airship to sail over a man's house without his permission. The very thought is enough to make a man feel chesty, and with good cause.

"When a wild anarchist buys a town lot he subsides into a moderate socialist. When he builds a house on the lot he fades into a conservative citizen. When he builds a house on it and transforms the house into a home, he is apt to join the Republican or Democratic party and begin to question the wisdom of strikes. When the boy is born he opens an account at the bank.

"A man who owns his home begins to study his ticket six weeks before election day. He scrutinizes every name on it and looks up the candidate's record. It is the man who can wrap up his personal and real property in a handkerchief that shuts his eyes and votes the folded ticket the boss gives him without unfolding it.—White Pigeon (Mich.) News.



## EDITORIAL

### PROGRAM FOR THE CONVENTION

The officers and committees who have charge of the work of preparing the program for the next convention of League are anxious to obtain suggestions.

What subjects are of the greatest general interest to the municipalities of California?

City officials may materially assist the the committee by sending word as to those matters they are most anxious to have taken up.

A proposition for simplifying the Vroman Act, an amendment to the municipal bonding act, and a bill for establishing a uniform system of accounting, will be submitted to the convention. City Attorneys and others having suggestions to offer on these or any other municipal questions are requested to mail them to the League headquarters in San Francisco.



### ILLUSTRATIONS FOR LECTURES

It has been suggested that many of the set talks delivered at our conventions would be made more effective and interesting by illustrated pictures. For instance, a talk on ornamental street trees would be far more instructive and interesting if accompanied by pictures showing successful examples of that work. The same may be said of almost any topic that may be discussed.

Therefore we would like to secure photographs showing samples of good street paving, particularly oil macadam, tree planting, parking, electric lighting, and all kinds of public buildings and works.

### AUTOMOBILE FIRE ENGINES

We have recently received many inquiries about automobile fire engines. These machines appear to have given satisfaction wherever installed and they possess so many advantages over the horse-drawn vehicle that it is probably only a matter of time when motor machines will be used exclusively. There are half a dozen different machines on the market and each one probably possess some feature in which it surpasses the others. With the idea of obtaining as much knowledge as possible about the different makes we would like to receive information from the officials of cities where these machines are used, mentioning particularly the strong points or defects of their respective machines.



### BETTERING THE CITIES

COLLIER'S WEEKLY AUGUST 13

For a dozen years State leagues of municipalities have been strong factors in the movement toward more efficiently managed cities. The League of California Municipalities is now in its thirteenth year, and holds annual conventions in some city within the State. The last convention was held at Santa Cruz and the program for the next one is now being arranged; it will be held at San Diego, November 16th to the 19th. The league publishes a monthly magazine devoted to municipal matters, which is mailed free to every city official.

The California League numbers 120 cities and towns in its membership. The League of Iowa Municipalities has the largest membership, with California second. Nebraska and Kansas were recently organized, and West Virginia, Iowa, Wisconsin, and other States have organizations of long standing.

The purpose of these organizations is in part—to give standards of comparison by which the different cities may know just what their rivals have done in systematic street-cleaning, sewage disposal, police troubles, and the like.

## What the Cities are Doing

- Oroville** has just joined the league.
- Sierra Madre** has joined the league.
- Auburn** streets will be oiled next year.
- Santa Paula** has voted \$45,000 for sewers.
- Santa Cruz** wants a garbage incinerator.
- Los Gatos** has adopted a building ordinance.
- Vallejo** will vote for freeholders on October 11th.
- Haywards** is doing a large amount of street work.
- Los Angeles** has started a fight against bill boards.
- Colton** will oil the main streets leading into the city.
- Gridley** grammar school is very much overcrowded.
- Alhambra** has adopted a milk inspection ordinance.
- Monterey** freeholders are busy framing their new charter.
- Santa Monica** will oil the playgrounds of Lincoln School.
- Los Angeles** spent \$1,280,398 for street paving last year.
- Redlands** has an increased valuation of \$315,000 over last year.
- San Leandro's** new \$60,000 grammar school is almost completed.
- Ventura** has voted \$75000 for a magnificent high school building.
- Monterey** is about to start the construction of a Carnegie Library.
- Sacramento** has increased 52.6 per cent in population since 1900.
- Delano** is declared not legally incorporated by the Supreme Court.
- Orland** contemplates the installation of a street lighting system.
- Lodi** trustees have reduced the electric light rates 6 cts per Kilowatt.
- Mayfield** has about completed the construction of its sewer system.
- San Francisco** has adopted a rigid ordinance regarding meat inspection.
- Pacific Grove** will issue bonds for a city hall and fire apparatus.
- Coalinga** has started proceedings for a \$40,000 bond issue for sewers.
- Oroville** has increased its assessed valuation \$100,000 during the past year.
- Oxnard** has a compulsory ordinance covering the numbering of houses.
- Ontario** is considering a bond issue of \$150,000 for a municipal water system.
- Marysville** is installing a large auxiliary pumping plant at its water works.
- San Bernardino** has formally declared in favor of a municipal lighting plant.
- San Diego** is making great preparations for the next convention of the League.
- Ukiah** has installed a sanitary drinking fountain in the Court House grounds.
- Pasadena** has nominated City Attorney Wood for Judge of the Superior Court.
- Vallejo** has put the lid on several so-called Social Clubs where liquor is dispensed.
- San Rafael** trustees have received an application for a street railroad franchise.
- Berkeley** has purchased a "Seagrave" automobile hose truck and chemical engine.
- Ocean Park** has commenced suit for the opening and extension of Linden Avenue.
- Burlingame** is contemplating the construction of a combination town hall and fire house.
- Upland** will soon have an electric road connecting with Claremont. The rails are being laid.
- Lincoln** is building a handsome new high school of terra cotta building blocks with a tile roof.
- Oakland** freeholders are preparing a new charter. Former Governor Pardee is one of the board.
- Sausalito** is contemplating extensive sewer work under the Local Improvement Act of 1901.
- Visalia** is after an additional donation from Andrew Carnegie for an addition to the public library.
- Fresno** has just secured a new official map platted by City Engineer Jensen: the last one dates back to 1885.
- Napa** sent its Street Foreman to Alameda to investigate the oil macadam streets of the latter city.
- San Mateo** proposes to build raised crossings at street intersections to stop automobile speeding.

**San Bernardino** has adopted an ordinance compelling hotels and lodging houses to keep registers.

**Los Angeles** has more automobiles than any other city in the United States, in proportion to her population.

**South Pasadena** expects a decision soon from the U. S. Supreme Court in the famous poolroom case.

**Fresno** has purchased six playground sites. The new Convention Hall will be located on one of the sites.

**Tulare** has called for another submission of bids for constructing its sewer system. The first bids were too high.

**Fresno** has just completed 1½ miles of 4 inch asphalt macadam pavement and is about to construct two miles more.

**Corning** has started proceedings for bonding the town for \$48,000 for a water plant and \$21,000 for a sewer system.

**Pasadena's** municipal lighting plant returned a net gain of \$36,784.80 last year besides paying \$15,000 interest on bonds.

**San Jose** has secured a Murphy Patent Automatic Street Flushing Machine from Henshaw Buckley & Co., on trial.

**Williams Union High School** bonds have been declared invalid on account of a technical defect in the form of the ballot.

**Chico** experienced some difficulty in disposing of \$20,000 bonds issued under the Local Improvement Act of 1901.

**Monrovia** will vote on the question of issuing \$120,000 bonds for sewers, and \$50,000 bonds for improving the water system.

**Vallejo.** The bonds of the High School District are declared invalid. A friendly suit may be brought to determine a point in dispute.

**Imperial** has a public spirited newspaper in the "Standard", which is donating 100,000 copies of a folder advertising the valley and town of Imperial.

**Monterey and Sausalito** are having their books examined by Mr. William Dolge, C.P.A., the well known expert and specialist on municipal accounting.

**Palo Alto** has been notified by Warren Brothers Company that certain pavement specifications adopted by them constitute an infringement of their patent.

**Modesto** will vote on September 6 for issuing bonds for the following purposes: Additional sewer system \$65,000; water works \$150,000; street work \$10,000; and fire apparatus.

**Santa Ana** will soon vote on the question of issuing bonds as follows:

Convention Hall, \$40,000; outfall sewer between \$65,000 and \$80,000; parks \$15,000; water-works, about \$30,000.

**Long Beach** will vote on the question of a special tax levy as follows: Municipal band, \$25,000; advertising and entertainment, \$7,000; park, \$30,000; public comfort stations on beach, \$10,000; fire hydrants, \$5000.

**Richmond's** City Council, who declined to recognize a petition for the recall of six of their members have been overruled on demurrer by Judge Buckles of the Superior Court, who said:

"The Council has no discretion or right to refuse to call an election when the petition for that purpose is presented and certified as required by the charter."

The Judge referred to the case of Good vs. San Diego, 5th App. 265.

**San Diego** supposedly voted bonds on ten propositions on June 10th, but according to a ruling of the Supreme Court, only five were carried, as follows:

No. 9—Additions to water system	\$340,000.00
No. 10—Additions to sewer system	92,500.00
No. 11—Additions to sewer system	26,000.00
No. 12. Additions to sewer system	74,000.00
No. 19. Improvements to Public Park	1,000,000.00



### "HYGENIC" DRINKING FOUNTAIN

For Schools, Railway Stations, etc. Prevents contagion and provides each user with an ample supply of fresh water.

Illustrated circular sent on request.

The newest things in plumbing fixtures for Schools, Factories and Office Buildings are on display in our Show Rooms.

851-859 Folsom Street, San Francisco, Cal.

Phones, Sutter 1130; Home J-2110

**Haines, Jones & Cadbury Co.**

Makers of Plumbing Supplies

1130-1144 Ridge Avenue, Philadelphia

Branches—Savannah and San Francisco



## LIST OF RESPONSIBLE FIRMS TO BE CALLED ON TO BID FOR PUBLIC WORK OR SUPPLIES

### WRITE FOR CATALOGS

This list is arranged as a guide for the accommodation of city officials where advertising for bids is not necessary.

- Accountant**  
William Dolge, C. P. A., 255 California St., S. F.
- Architects**  
W. H. Weeks, 251 Kearney St., S. F.
- Asphalt Machinery**  
A. L. Young M'chy Co. 26-28 Fremont St., S. F.
- Arch. Terra Cotta**  
Gladding, McBean & Co., Crocker Building, S. F.
- Automobile Public Service Wagons**  
Consolidated Motor Car Co., Cor. Van Ness and McAllister Sts., S. F.
- Bitulithic Pavement**  
Warren Brothers Company, Los Angeles, Cal.
- Bridge Builders**  
Keatinge-Bradford Co., 615 Humboldt Bk Bdg.
- Concrete Construction**  
Keatinge-Bradford Co., 615 Humboldt Bk Bdg.
- Contractors and Builders**  
Finch Jail Building and Metal Co., 16 California St., S. F.
- Constructing Engineers**  
Fred'k C. Roberts & Co., 221 Sheldon Building, S. F.  
Standard Engineering Co., 503 Market St., S. F.
- Consulting Engineers**  
Spaulding, Sloan & Robson, 802 Union Trust Building, San Francisco.
- Drinking Fountains**  
Haines, Jones & Calbury Co., 851-859 Folsom St., S. F.
- Dump Carts and Wagons**  
A. L. Young M'chy Co., 26-28 Fremont St., S. F.
- Electrical Plants & Machinery**  
A. L. Young M'chy Co., Fremont St., S. F.  
Chas. L. Kiewert Co., 195 Fremont St., S. F.  
Standard Engineering Co., 503 Market St., S. F.
- Engravers and Bond Printers**  
Commercial Art Co., 53 Third St., S. F.  
Schmidt Lithograph Company, Second & Bryant Sts., S. F.  
Sierra Art Engraving Co., Front & Commercial Sts., S. F.
- Fire Alarm and Police Tel. Systems**  
Gamewell Fire Alarm Tel. Co., Market and Battery Sts., S. F.
- Fire Apparatus**  
Cal. Fire Apparatus Co., Jessie and New Anthony, S. F.
- Fire Dept. Equipment**  
R. S. Chapman, 400 Golden Gate Ave., S. F.
- Fire Engines**  
Gorham Rubber Co., 50-56 Fremont St., S. F.
- Fire Extinguishers**  
Goodyear Rubber Co., 589 Market St., S. F.
- Fire Hose**  
Gorham Rubber Co., 50-56 Fremont St., S. F.
- Eureka Fire Hose M'fg Co., 610 Postal Tel. Building, S. F.  
New York Belting & Packing Co., 129-131 First St., S. F.
- Gasoline Engines**  
Doak Gas Engine Co., 7-9 First St., S. F.
- Lithographers**  
Schmidt Lithograph Company, Second & Bryant St., S. F.
- Metal Furniture**  
Finch Jail Building and Metal Co., 16 California St., S. F.  
Art Metal Construction Co., Flood Bldg., S. F. Story Building, Los Angeles.
- Municipal Accountant**  
William Dolge, C. P. A., 255 California St., S. F.
- Municipal Lawyers**  
Mason & Locke, 904 Pacific Building, S. F.
- Municipal Printers**  
A. Carlisle & Co., 251-253 Bush St., S. F.
- Municipal Pumping and Water Service**  
Fredk. C. Roberts & Co., 461 Market St., S. F.  
Standard Engineering Co., 503 Market St., S. F.
- Pavement Materials**  
Warren Brothers Company, Los Angeles, Cal.
- Playground Apparatus**  
A. L. Young Machinery Co., S. F.
- Reinforced Oil Concrete Streets**  
E. M. Chadbourne Co., 800 Postal Tel. Building, S. F.
- Road Machinery**  
J. I. Case Threshing Mch. Co., 616 Myrtle St., Oakland, Cal.  
Henshaw, Bulkeley & Co., Fremont St., S. F.  
A. L. Young M'chy Co., Fremont St., S. F.  
Petrolithic Pav. Co., 209 E. 7th St. Los Angeles.
- Safes**  
Cary Safe Co., 669-671 Mission St., S. F.  
Parcells Safe Co., 577 Market St., S. F.  
Victor Safe & Lock Co., 1292-4 Market St. S. F.
- Scrapers**  
A. L. Young M'chy Co., Fremont St., S. F.  
Petrolithic Pav. Co., 209 E. 7th St., Los Angeles.
- Sewer Pipe and Terra Cotta**  
Gladding, McBean & Co., Crocker B'ldg, S. F.  
Steiger Terra Cotta Co., Mills B'ldg., S. F.
- Street Signs**  
A. L. Young Mch. Co., S. F.
- Street Sweepers**  
A. L. Young M'chy Co., Fremont St., S. F.
- Vaults**  
Cary Safe Co., 669-671 Mission St., S. F.  
Parcells Safe Co., 577 Market St., S. F.  
Victor Safe & Lock Co., 1292-4 Market St., S. F.
- Water Supply**  
Doak Gas Engine Co., 7 and 9 First St., S. F.

**WILLIAM DOLGE**

*Certified Public Accountant --:-- Municipal Accountant*

TELEPHONE DOUGLAS 5173

255 California Street

San Francisco, Cal.

**WM. H. WEEKS, Architect**

PUBLIC BUILDINGS A SPECIALTY

251 Kearney Street

San Francisco

**SPALDING, SLOAN & ROBSON**  
CONSULTING ENGINEERS

Waterworks, Sewer Systems, Paving, Lighting Plants

Telephone Kearney 4646

802 Union Trust Building, SAN FRANCISCO

Chas. P. Bradford, President

M. Keatinge, Vice-Pres. and Supt.

Howard J. Van Kirk, Secretary

**KEATINGE-BRADFORD COMPANY**

Concrete Contractors and General Contractors

Telephone, Kearny 2921

Room 615 Humboldt Bank Building

SAN FRANCISCO

**GORHAM RUBBER CO.**

RUBBER GOODS OF EVERY DESCRIPTION

Fire Hose, Chemical Engines, Hose Carts, Packing

**50-56 Fremont St., San Francisco**

W. J. LOCKE

H. A. MASON

**Mason & Locke**

ATTORNEYS AND COUNSELORS AT LAW

*Bond proceedings conducted---validity and sale guaranteed*

Ninth Floor Pacific Building

SAN FRANCISCO

The  
Bitulithic  
Pavement  
For Streets  
and Roads



1 Mile	7 Cities
22 Miles	33 "
52 "	40 "
59 "	45 "
59 "	42 "
85 "	57 "
109 "	66 "
95 "	62 "
118 "	74 "
679 "	216 "

**TOTAL MILES (30 Ft. Road)**

Combines the inherent stability of the mineral aggregate with the cementing qualities of the asphaltic oil, or other bituminous cement, and produces a smooth, dustless, waterproof pavement, suitable for automobile traffic and driving--prevents skidding and affords a good foothold for horses--is COVERED BY PATENTS, the VALIDITY of which has been SUSTAINED BY THE SUPREME COURT OF THE UNITED STATES.

Send for circulars showing where used and methods of construction.

**WARREN BROTHERS COMPANY**

Portland, Ore.

Boston, Mass.

Los Angeles, Cal.

616 Laughlin Bldg.

REGISTERED TRADE MARKS

"Bitulithic" "Warrenite" "Puritan" "Bitrock" "Bituminous Macadam" "Bi'ustone"

**MAPS**  
**BONDS**  
**STATIONERY**  
**BOOKLETS**  
**POSTERS**  
**LABELS**  
**CARTONS**  
**ETC.**

**SCHMIDT LITHOGRAPH COMPANY**

MAIN OFFICE  
SAN FRANCISCO.

PORTLAND      LOS ANGELES

**FINCH JAIL BUILDING AND METAL CO.**



Manufacturers and Builders of

**PRISON CELLS AND ALL APPURTENANCES.**

Dealers in Metal Furniture and Fixtures

Office No. 16 California St.

Telephone Kearney 935



# SPECIAL BARGAINS IN THE BEST MAGAZINES

1. Review of Reviews - - \$3.00	} All For	\$3.25	2. Review of Reviews - - \$3.00	} All For	\$3.50
American Magazine - - 1.50			Woman's Home Companion 1.50		
Sunset Magazine - - 1.50			Sunset Magazine - - 1.50		
3. American Magazine - - \$1.50	} Both For	\$2.00	4. Woman's Home Companion \$1.50	} Both For	\$2.25
Sunset Magazine - - 1.50			Sunset Magazine - - 1.50		
5. American Magazine - - \$1.50	} All For	\$2.75	6. Technical World - - \$1.50	} Both For	\$2.35
Woman's Home Companion 1.50			(or World Today)		
Sunset Magazine - - 1.50			Sunset Magazine - - 1.50		
7. Forest and Stream - - \$3.00	} Both For	\$3.00	8. Van Norden's - - \$1.50	} Both For	\$2.00
Sunset Magazine - - 1.50			Sunset Magazine - - 1.50		
9. Forest and Stream - - \$3.00	} All For	\$3.50	10. American Magazine - - \$1.50	} All For	\$2.75
Woman's Home Companion 1.50			Technical World - - 1.50		
Sunset Magazine - - 1.50			Sunset Magazine - - 1.50		
11. Review of Reviews - - \$3.00	} All For	\$3.10	12. McClure Magazine - - \$1.50	} Both For	\$2.35
Van Norden's Magazine 1.50			Sunset Magazine - - 1.50		
Sunset Magazine - - 1.50					
13. Scientific American - - \$3.00	} Both For	\$3.00	14. Review of Reviews - - \$3.00	} At Half Price	\$5.25
(New subscriptions only)			Technical World - - 1.50		
Sunset Magazine - - 1.50	Van Norden's Magazine 1.50				
	Sunset Magazine - - 1.50				
	Sunset Magazine - - 1.50				

## Sunset Magazine, \$1.50 the Year

CLUBS may be split to go to different addresses.

FREE with each order, two beautiful four color pictures of Yosemite Valley, ("El Capitan" and "Vernal Falls") handsomely mounted. These pictures will be sent flat, not rolled.

POSTAGE to Canada is 50 cents extra on each magazine; to foreign countries is \$1.00 extra.

### SUNSET MAGAZINE FOR 1910 INCLUDES

- (1) A California novel "The Rules of the Game" by Stewart Edward White—  
to be run as a serial.
  - (2) Mexico Today—a series of articles of great interest, by one high in author-  
ity in our sister republic.
  - (3) Alaska and the Alaskans, by Governor Walter E. Clark.
  - (4) The best fiction by such authors as Jack London, Billie Glynn, Eleanor  
Gates, Dave Coolidge, James Hamilton Osborne, etc.
- And many other special features.

ADDRESS

## SUNSET MAGAZINE

313 Battery Street

San Francisco

# MUNICIPAL AND CONTRACTORS' MACHINERY

...FOR...

## GOOD ROADS AND STREETS

Street Signs  
National Road Machines  
Fort Wayne Road Machines  
Indiana Road Machines  
National Elevating Graders  
Elevators—Portable Bunkers  
Shares or Cutting Edges for all types of Road Machines  
Rock Crushers, Jaw and Gyratory Type, mounted and unmounted  
Screens  
Steam Road Rollers  
Horse Rollers  
Scarifiers  
Harrows for oiled roads  
Wheeled and Drag Scrapers  
Fresno Scrapers  
Reversible Road Plows  
Street Sprinklers  
Sprinkling Attachments  
Street Sweepers  
Fibre for Street Sweepers  
Patent Dump Wagons  
Asphalt Machinery  
Kettles—Hand Rollers—Tampers  
Concrete Mixers  
Hoisting Engines  
Playground Apparatus  
Culvert Pipe

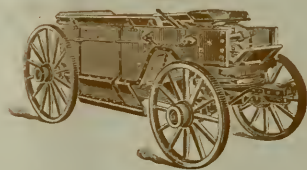
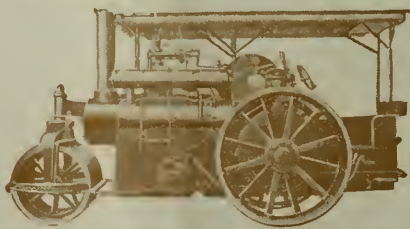

Write us for Catalogues and Estimates

## A. L. Young Machinery Co.

26-28 Fremont Street

San Francisco

California

# PACIFIC MUNICIPALITIES

THE CITY BEAUTIFUL



PUBLIC  
SAFETY  
HEALTH  
CONVENIENCE

PUBLIC  
UTILITIES  
EDUCATION  
RECREATION

PUBLISHED MONTHLY

SIERRA SF



## ROAD MEN NEED THESE IMPLEMENTS

*A very successful street superintendent writes:*

"Having used the **Gang Rooter Plow** for several months to break up street surfaces, either oiled or natural, I take pleasure in recommending the same, and our experience has been that the work can be done at much less cost than by the old method of plowing the streets. I also take pleasure in recommending the **Spike Disc Harrow** for pulverizing rough plowed streets or for breaking up oiled surfaces that have become rough by buckling. *After oiled streets have been spiked and smoothed up and rolled the result is often a much better road than when the oiling was first done.*"

SEND FOR CATALOG.

## PETROLITHIC PAVEMENT CO.

336 Pacific Electric Bldg., Los Angeles, Cal.

SILENT

LUXURIOUS

3 MODELS

THE <sup>NEW</sup> Rambler

Touring Cars, Motor Fire Trucks, Chemical, Hose,  
Police Patrol and Ambulances a Specialty.

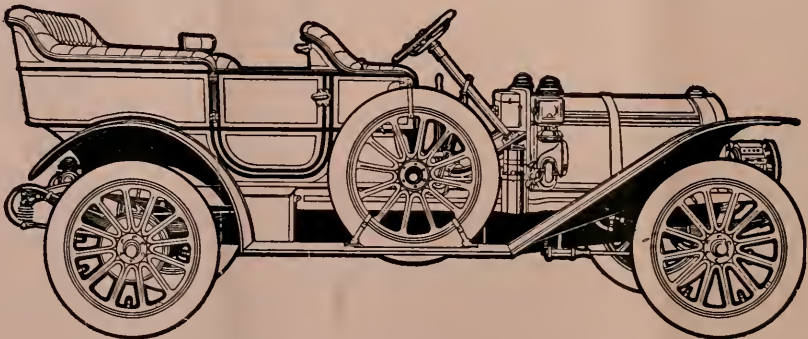

**The Thomas B. Jeffery Co.**

117-125 Valencia St.

WRITE FOR INFORMATION.

San Francisco

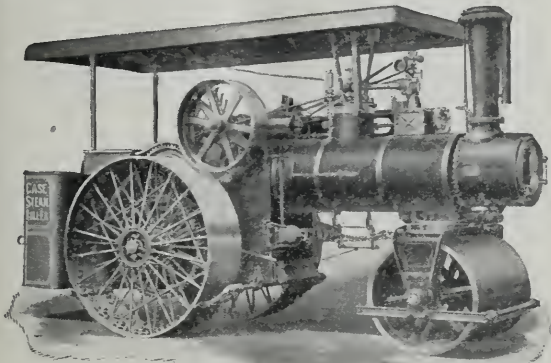

# CASE

36 Horse Power  
10 Ton Road Roller

Time Price--with Simple Cylinder  
**\$2,200**  
 with Compound Cylinder  
**\$2,300**

10 per cent Discount for Cash.

**The Only Spring-Mounted Road Roller Built**

CASE Rollers have greater fuel and water carrying capacity than others

---

**We sell the well known line of TROY Dump Wagons and Dump Boxes**

---

Road Rollers—Catalog 36. Contractors' General Purposes Engine and Municipal Tractor—  
 Catalog 37. Address Road Machinery Dep't.

**J. I. CASE THRESHING MACHINE COMPANY, Inc.** RACINE, WIS.,  
 U. S. A.

OAKLAND, CAL., BRANCH OFFICE, 616 MYRTLE ST.

Insure your Valuable  
 Papers with

**Parcells Safe Co.**

AGENTS

**“Diebold” Safes and “Allsteel” Metal Furniture**

577 MARKET STREET

SAN FRANCISCO

---

*Especially for Municipal Exploitation*

---



*Write to Us*

**Sierra Art & Engraving Co.**

Front and Commercial Sts., San Francisco

# Henshaw, Bulkley & Co.

## ROAD MACHINERY

### A SPECIALTY

19-21 Fremont Street  
San Francisco

262-264 So. Los Angeles St.  
Los Angeles

# The Commercial Art Co.

INCORPORATED

## Designers & Engravers

53 Third Street

San Francisco

TERRA COTTA, PRESSED BRICK, PIPE,  
FIRE PROOFING, ROOFING TILE,  
FLUE LININGS, FIRE TILE,  
LAUNDRY TRAYS,  
ETC.

**GLADDING, McBEAN & CO.**

WORKS  
LINCOLN, CAL.  
--- OFFICE ---  
311-317 CROCKER BLDG., SAN FRANCISCO.

# Steiger Terra Cotta and Pottery Works

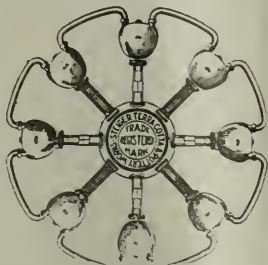

MAIN OFFICE AND YARDS:

City Yard, 18th and Division Streets

Main Office: 729 Mills Building

Phone Douglas 3010

SAN FRANCISCO, CAL.

Factory, South San Francisco  
San Mateo County



NOTE—Every city official in California reads Pacific Municipalities.

# Pacific Municipalities

OFFICIAL ORGAN OF THE LEAGUE OF CALIFORNIA MUNICIPALITIES

Entered at Post Office, Santa Clara, Cal., as Second-Class Matter

---

VOL. XXIII

TWELFTH YEAR

No. 2

---

EDITORS - - - H. A. MASON AND WM. J. LOCKE  
EDITORIAL OFFICE - NINTH FLOOR, PACIFIC BLD'G, SAN FRANCISCO  
PUBLICATION OFFICE, - - - SANTA CLARA, CALIFORNIA

---

## CONTENTS FOR SEPTEMBER, 1910

---

First Annual Report (in part)—Beverly L. Hodghead	37
Side Lights on Municipal Accounting and Administration	45
The Next Convention (Continued)	47
Corona Grammar School	51
The Warren Patent	52
Dues Received	54
Questions and Answers	54
Items of Interest	55
What the Cities Are Doing	59

---

Published Monthly. Yearly Subscription, \$2.00 in Advance. Single Copies, 20 Cents

ADVERTISING RATES ON APPLICATION

Address all Communications to "PACIFIC MUNICIPALITIES" Pacific Building  
San Francisco, California

# LEAGUE OF CALIFORNIA MUNICIPALITIES

Organized 1897

## — OFFICERS —

President	(Mayor of Riverside)	S. C. EVANS
First Vice-President	(City Clerk of Monterey)	W. E. PARKER
Second Vice-President	(Mayor of Berkeley)	BEVERLY L. HODGHEAD
Secretary	H. A. MASON	Assist. Secretary WM. J. LOCKE

## STANDING COMMITTEES

EXECUTIVE—S. C. Evans, President; H. A. Mason, (Sec.) San Francisco; Clinton L. White, Mayor of Sacramento; A. E. Dodson, Councilman, San Diego; H. P. Brainerd, Mayor of Petaluma.  
 LEGISLATIVE—H. L. Partridge, San Jose; M. J. Rogers, Ventura; Hugh R. Osburn, Santa Cruz; James H. Gray, Santa Rosa; S. G. Long, Long Beach.  
 JUDICIARY—C. N. Kirkbride, San Mateo; Perry L. Wood, Pasadena; O. G. Hopkins, Sacramento; W. P. Butcher, Santa Barbara; Wallace Rutherford, Napa.  
 ENGINEERING—W. F. McClure, Berkeley; H. B. Kitchner, Watsonville; Orlin Hudson, Richmond; C. P. Jensen, Fresno; S. J. Van Ornum, Pasadena.

Secretary's Office and Headquarters of the League, - Pacific Building, San Francisco

## INFORMATION BUREAU

The League of California Municipalities maintains, in connection with the Secretary's Office, an Information Bureau where the officials of the municipalities belonging to the League can secure information on all subjects relating to municipal affairs.

## MEMBERSHIP

Alameda	Lompoc	San Buenaventura
Alhambra	Long Beach	San Diego
Anaheim	Los Angeles	San Francisco
Antioch	Los Banos	San Jose
Auburn	Los Gatos	San Leandro
Benicia	Loyalton	San Luis Obispo
Berkeley	Madera	San Mateo
Biggs	Martinez	San Rafael
Bishop	Merced	Santa Ana
Black Diamond	Mill Valley	Santa Barbara
Burlingame	Modesto	Santa Clara
Calistoga	Monterey	Santa Cruz
Chico	Mountain View	Santa Maria
Coalinga	Napa	Santa Monica
Colusa	Nevada City	Santa Paula
Coronado	Newman	Santa Rosa
Corona	Newport Beach	Sausalito
Covina	Oakland	Sebastopol
Crescent City	Oceanside	Selma
East San Jose	Orange	Sierra Madre
Elsinore	Oroville	Sisson
Emeryville	Oxnard	Sonoma
Escondido	Pacific Grove	Sonora
Etna	Palo Alto	South Pasadena
Eureka	Pasadena	South San Francisco
Fairfield	Petaluma	St. Helena
Ferndale	Piedmont	Stockton
Fort Jones	Pinole	Suisun City
Fresno	Placerville	Susanville
Gilroy	Pleasanton	Tehachapi
Glendale	Point Arena	Tulare
Hanford	Pomona	Vacaville
Hayward	Red Bluff	Vallejo
Hercules	Redding	Visalia
Hermosa Beach	Redlands	Watsonville
Huntington Park	Redondo Beach	Whittier
Imperial	Redwood City	Willits
Jackson	Richmond	Winters
Lakeport	Rio Vista	Woodland
Lemoore	Riverside	Yreka
Livermore	Sacramento	
Lodi	San Bernardino	

Every city belonging to the League of California Municipalities is entitled to a free copy of this magazine every month for each of its officials; if not received kindly notify the Secretary.

**See that your City is in the above list.**

# PACIFIC MUNICIPALITIES

A Journal for Progressive Cities

VOL. XXIII

SEPTEMBER 30, 1910

No. 2

## FIRST ANNUAL REPORT

(in part)

of the Mayor of Berkeley

BEVERLY L. HODGHEAD

UNDER COMMISSION PLAN OF GOVERNMENT

TO THE COUNCIL OF THE CITY OF BERKELEY:

The charter provides that the Mayor shall annually, and from time to time, give the Council information relative to the affairs of the City, and recommend for its consideration such matters as he may deem expedient. Under the system which the Council has established of convening daily, either in committee or in legislative session, to consider all questions as they arise, this injunction of the charter becomes less necessary, because each member, by means of these daily conferences, acquires full information relative to the affairs of the City and of each of its departments.

The new charter has now been in effect for the period of one year. I submit herewith the annual reports of the commissioners and heads of departments, which taken together will furnish an account of the operation of the charter during that period.

The Council has felt a dual responsibility since its members assumed office a year ago. First, there has been the responsibility of endeavoring at least to justify the faith reposed in us by the people, and second, the responsibility of justifying and upholding the merits of the new charter as a form of municipal government.

The adoption of the charter, which was framed generally upon the commission plan, is a somewhat radical departure in the form of city government. It might still be said to be in an experimental stage. If it proves to be successful, the precedent is quite likely to be followed, as it has already been followed in other places. If it proves a failure here, it is very sure to be rejected in other cities.

I am convinced that the Berkeley charter is an instrument, under the form of which any city can, if its interested citizens so desire, secure an efficient government. That depends largely upon the people. I think the efficiency of any government is more a question of men than of constitutions or of charters, but that form of charter is to be preferred which provides the best method for the selection of its officials and makes the wisest distribution of its powers. A good charter therefore, is an aid to good government.



In my year's experience with the Berkeley charter, an experience into which has been crowded quite a full measure of duties, responsibilities and problems pressing for solution. I am free to express my own opinion that it is on the whole satisfactory. Before its adoption it was considered good in theory. Since it became effective it has proven practical in operation.

#### COMMISSION CHARTERS.

Improvements no doubt will be suggested from time to time, drawn from a fuller experience with commission charters, but the reforms which they have already accomplished and the improvements in general municipal conditions, which their introduction has effected in the sixty or seventy cities where such form of charter has been adopted, indicate very strongly that this movement, which has already attained very general proportions, for changing the government of cities from a political to a business basis, is no spasmodic upheaval or passing wave of reform, but is a prudent and thoughtful transition to a permanent and lasting system. While essentially democratic, it is at the same time the highest type of representative government. The councilmen are the representatives of the people rather than of any political party or organization. They are clothed with authority and charged with the duty of action, but the ultimate power is with the people if necessity arises for its exercise. They are not without a remedy if evils are to be corrected. I believe in representative government. It is necessary for efficiency where expert knowledge is demanded, but I believe that representative government will be more efficient and more in accord with the people's will if the power is reserved to the people to act where necessity justifies their action.

#### SUGGESTIONS AS TO THE INITIATIVE, REFERENDUM AND RECALL

But this power of the initiative, to remain useful and effective, should be guarded with such restrictions as will prevent its abuse, and forestall the unwarranted interference with the proper administration of the government. The city should not be thrown into the turmoil and expense of frequent elections because some individual or set of individuals feels it has some fancied grievance, or some politician or agitator imagines he has a new toy. The abuses in representative government have resulted in the tendency to substitute a more democratic form. If, in turn, these democratic privileges, viz., the initiative, the referendum and the recall, are themselves abused by resorting to them needlessly, it will no doubt likewise ultimately result in their abolition. They may be useful expedients but should be rarely employed. Their mere existence has a wholesome effect. Their usefulness, however, would be weakened if frequently invoked, particularly if no vital issue or policy is involved.

But one petition for the adoption of an ordinance has been filed under the Berkeley charter and that was found by the clerk to be insufficient. The value of these remedies therefore is with us still largely theoretical. No judgment could be formed which would be based upon a full experience.

#### THE VALUE OF PETITIONS

Considering the element of chance in elections and the indisposition of a great number of citizens to exercise the high privilege of suffrage, I think the powers granted to the council in the commission form of government are too great to vest in one body of men without some remedy being reserved to the people in case of a violation of trust. It is to be hoped, however, that some more satisfactory method

may be devised for initiating proceedings, than by the present system of petitions which, owing to the well known thoughtless practice and accommodating habit of signing petitions of whatever nature, but too often represent only the hopes and desires of the promoters of the proceeding rather than the well considered judgment of the great body of signers. The uncertainty, the element of chance in elections, and the possibility of the people making a mistake, is strong enough in my judgment, to justify the extraordinary remedies of the initiative, and the referendum, and under certain conditions the recall, but, I repeat, that there should be some more reliable method of exercising and initiating these remedies, than by the present loose system of government by petition. It often happens that the signers of such petitions are the least informed about their contents and objects, and thus the voters by the misuse of the privileges granted, may subvert the purposes of the charter.

Government by petition, if the privilege is wisely exercised, is a valuable right, but if it be abused, it may be productive of more harm than good and eventually defeat its own purposes.

One remedy is suggested in the increase of the percentage, which however, would be but a very imperfect remedy as it would only increase the degree of misrepresentation of the public mind. Another may be found in devising some means of bringing the petitioner to understand and realize the nature of his petition and to fully appreciate the responsibility of his act of citizenship exercised by him in signing such petition, which right should be restricted and guarded as securely as the right and privilege of voting. There might also be some provision for a brief statement in the petition of the reasons for and against the proposed ordinance, or some public hearing and discussion of the merits of the subject before it becomes mandatory on the council to call the election.

#### MINOR CHANGES IN THE CHARTER RECOMMENDED

*Tax Rate.* There may be some minor particulars in which the charter may be improved. One relates to the tax rate. The maximum rate provided by the charter for municipal purposes and for schools combined is one dollar per hundred dollars of valuation. Of this sum, only sixty five cents must be devoted to the support of the schools. But the levy for school purposes is not entirely a municipal affair. It cannot be governed entirely by the charter, but is subject to general laws. In fact, subsequent to the adoption of the charter, the legislature passed an act providing for the levying of taxes for high school purposes by county boards of supervisors, which body is not controlled by the city charter. I think it would be better to provide a separate tax rate for general municipal purposes, exclusive of the schools, and in my judgment the present rate of sixty-five cents on each hundred dollars of valuation is sufficient for the city's needs. That was the levy made last year and as will be seen later on, we came out at the end of the year with a considerable surplus, notwithstanding some unexpected and extraordinary expenses.

*Board of Equalization.* The requirement that the council shall sit as a board of equalization each day from the first to the last Monday in August is unnecessary. It works no inconvenience on the present council as we meet every day anyway; but the volume of business would not require the council to convene as a board of equalization for such a period of time. The council met as such board during the month of August last as required by the charter, but only two complaints were presented. These were disposed of in a few minutes. If the charter required all protests to be filed before a given date, say the 20th of August, the board could

then meet and probably dispose of the entire business in one or two sessions and all parties would have a better opportunity to be heard.

There may be a few other particulars wherein improvements might be suggested, but they are of minor importance. On the whole the charter has worked satisfactorily.

#### A WORD ABOUT HOW THE CHARTER HAS BEEN RECEIVED

The Berkeley charter has provoked considerable discussion and comment among the cities in the State and there has been a continuous stream of inquiry concerning it, both here and in other States. A great many applications have been received for copies of the charter and for information as to its operation, coming from points in California and from some twenty or thirty of the other States of the Union. The information is generally sought by boards of freeholders which have municipal charters in course of preparation.

The provision for elections which is original in our charter has attracted the widest attention. The principle has been recommended by the charter committee of San Francisco. It has been incorporated into the charters of Tacoma and Colorado Springs and is receiving favorable consideration in many other cities that are now engaged in the work of preparing charters. I look to see this provision of our charter very generally adopted as it appears to afford a satisfactory solution of one of the most troublesome of municipal problems.

Mr. Clinton Rogers Woodruff, the secretary of the National Municipal League, in his report on the American Municipal Situation read before the last convention of the league in Cincinnati in November, 1909, some considerable space to a description of the operation of this provision of the Berkeley charter.

#### OPERATION OF THE CHARTER.

The first duty of the council after organization was the assignment of the councilmen to the different departments. There was little difficulty in making such selection as the individual members possessed special qualifications for their respective duties. The work of the various departments established by the charter has proven to be about evenly distributed. When the charter was adopted I thought that the work of the commissioner of public supplies would be the lightest, but it has proven to be one of the busiest departments. That commissioner is the purchasing agent of the city. More than three-fourths of the expenditures of the city are made through the department of public works and the department of public health and safety. The budgets of these departments as well as all others are submitted to the council for consideration through the commissioner of finance and revenue. Through his recommendations and the economical administration of the above departments by the commissioners thereof, and the diligent attention of the commissioner of public supplies in making the purchases for all the departments, is due the surplus of nearly \$33,000 in the treasury at the close of the fiscal year, exclusive of \$8,750 on hand in the Cash Basis Fund.

#### METHODS OF THE COUNCIL.

In the transaction of the business of the city during the past year, the proceedings of the council have been entirely harmonious and agreeable. There has been no clashing of interests, for the interests of all the members have been the same. The judgment of public officers is sometimes influenced by the interests they represent, and if those interests are antagonistic, the differences cannot be reconciled. My experience has confirmed the opinion I had occasion to express



at the time of assuming office, that I believed the people had elected a council of men, each with a judgment of his own, but with a willingness and readiness to accept the views of others if they are convincing. We have differed in opinion on many subjects at the beginning of our investigation. Our final opinions, however, have been reserved until we have first, as far as possible, become fully acquainted with all the facts in each case and until there has been a full conference and interchange of views among the members. The reason we have been able to agree is, we have not prejudged questions before all the members have had an opportunity to hear all the facts, and we have not acted on ex parte statements alone. Where there is no councilman who has any special interest or particular section or class to represent or serve, it is made comparatively easy to reach an agreement after coming into possession of the facts in each case. As a consequence no question of importance has arisen during the year, on which the final judgment of the members has not been in accord. I can see no reason why under such conditions councilmen should not be able to agree as readily as the appellate courts agree upon the proper judgment to be entered in any case.

#### PUBLIC SENTIMENT IN MUNICIPAL GOVERNMENT

We are fortunate in Berkeley in having a pronounced public sentiment in favor of good government and in favor of the charter. That fact has made the work of the council easier but has made the test of the charter less severe. Some of the opponents of this plan of government admit that it might work successfully in Berkeley, but contend that it would not be suitable in cities where municipal conditions are different. There may be some force in the argument. It is a greater compliment, however, to the city than to the charter. Government is based on sentiment and is good or bad as sentiment is good or bad. The general interest manifested by the people in the government has been a great assistance to and reliance of the council. We come in contact with people of many minds and with various motives and purposes. We are occasionally misrepresented, sometimes thoughtlessly, sometimes, perhaps, willfully. We are occasionally criticized, sometimes justly and sometimes from other motives. Some form opinions based on erroneous information or ex parte statements. But we feel encouraged and secure in the fact, that on the whole we are not being judged by ignorance, nor selfish, politics. A progressive, effective and non-political city government cannot long exist without the support of a pronounced public opinion ready to defend it and to resist any assault from political motives upon its integrity.

Political reform has two aspects. Reform in the method of transacting public business has been toward a system which has proven effective in the management of private enterprise. Our charter is adapted to effect this result by eliminating purely political influence from the control of the government. The change in the attitude of the people is manifested by the disposition to look upon the government, not as a system devised for the distribution of spoils, but to regard the governing body as a tribunal for the determination of the rights of all citizens between themselves and the effective management of the city's affairs.

#### THE CHIEF MERITS OF THE CHARTER

The provision of the charter for a small council with large powers and full responsibilities to the people, is in my judgment a wise provision. The work is more expeditious and less cumbersome. Each commissioner is responsible in a measure for his department, but by meeting in daily session the various members of the council become familiar with the work of all the departments.

The Berkeley charter originated a system of dual elections which was designed by the freeholders to arouse an interest among the non-political and business element of the community in the selection of public officials. The system devised here, as has been seen, has been copied into other charters and is being considered in many cities where boards of freeholders or charter committees are in session.

The chief merits of the charter lie in this provision for the dual election, in the concentration of official power and responsibility, in the abolition of wards and in the general plan of co-ordinating and unifying the administrative departments of the government.

This system in my judgment, is superior to the disjointed policy of divided authority and independent action by different elective officers not accountable to each other or to any other body. The weakness and inefficiency of the different administrative phases cannot be corrected unless the authority is vested in some governing body. There can be no consistent policy enforced throughout municipal government unless the power is given to one set of men. As far as I am able to ascertain, the system is satisfactory to the chief officials of the city and heads of departments who hold their offices by appointment and who serve during the pleasure of the council. They have all worked in harmony with the council, they have learned that their tenure depends upon the quality of service, which is a matter under their own control, and not upon political strength, which is a shifting and uncertain tenure. They have this incentive to do efficient work and are relieved of considerable responsibility by being able to council with the governing body of the city.

#### REVISION OF CITY ORDINANCES

One of the principal duties of the council has been the revision and compilation of all the ordinances of the city—to make them harmonize with the charter and with each other. The new charter established the chief officials of the city, but did not define their powers and duties. It left these to the council to prescribe by ordinance. The charter also continued in force all existing ordinances not inconsistent therewith until amended or repealed. Under the town government some of the corresponding offices were established and the duties defined by the charter itself, which was repealed by the adoption of the new charter. The powers and duties of the officers which were prescribed by ordinance were however continued in force. New ordinances defining the duties of the charter officials, except in cases appearing to be urgent, would not be effective for thirty days from their final adoption. The council has adopted a new set of ordinances defining and prescribing the duties and powers of all the chief officials of the city established by the charter, which repeal the old ordinances and take the place of the corresponding provisions of the old charter. In some cases, while awaiting the thirty day period to elapse, temporary appointments were made. The salaries of all officers are fixed by resolution of the council, but under the old system some of the salaries were fixed by ordinance and those had to be repealed by ordinance and the thirty day period allowed to elapse. There were thus some complications encountered in the transition from the old system to the new.

Besides the above, some of the principal ordinances which have been adopted are the following: The ordinance distributing and assigning the executive and administrative powers, authority and duties of the city among the several departments, officers and commissioners; the ordinances providing for the organization of the police department, of the fire department, the regulation and management

of wharves, for the creation of a board of health, and park commission and playground commission, and commission of public charities, and defining the powers and duties of the respective officers, and an ordinance prescribing the duties of the board of library trustees; an ordinance providing a system for the levying and collection of municipal taxes; regulating the manner of keeping and storing petroleum and combustible material; various ordinances establishing street grades and accepting streets, and declaring boulevards; regulating plumbing and providing for the registration of plumbers; prescribing rates of toll, dockage and wharfage; requiring the equipment of street cars with fenders and wheel guards; and various ordinances of a sanitary nature; numbering in all about one hundred. Other ordinances are under consideration, notably an ordinance regulating the construction of buildings. Considerable progress has been made during the year by the various companies in removing wires from the streets and placing them underground. This should be regulated by ordinance and districts established wherein all wires carrying electric currents should be removed from the streets.

The work of revising and compiling the entire body of ordinances of the city is now about complete, and as soon as they are classified and indexed it will be the duty of the council to cause them to be published as required by section 34 of the charter.

### FINANCES

One of the most important duties and functions with which we are charged is the wise and economical management and disbursement of the funds of the city. More especially are we charged with the duty of securing an adequate return in value or service for each dollar of outlay. We have not assumed, however, that we were elected to economize to the extent of inefficiency of service, but are to pursue a prudent and liberal policy in providing for the public needs. Economy is not parsimony and liberality not extravagance.

We have prepared at the end of each month, a report of the expenditures during that month in the maintenance of the various departments, as well as the expenditures to that date, with a statement of the balance of the original estimate remaining unexpended. The departments also submit at the beginning of each month an estimate of the expenditures likely to be required which must be approved by the council.

Under the old charter the tax rate, exclusive of bonds and library tax, was seventy-five cents, of which thirty cents was for the schools. The rate for general municipal expenses was forty-five cents which appeared to be ample when the charter was adopted in 1895, at a time when the city had but a volunteer fire department, a single town marshall instead of a police force, few lights and little expense in connection with the streets. The tax rate in the new charter is one dollar of which thirty-five cents is appropriated for school purposes and two and one half cents is required to be set apart into the Cash Basis Fund. So that the rate for municipal purposes is sixty-two and one-half cents, or seventeen and one-half cents greater than the rate provided by the old charter. Notwithstanding this increase, the rate is still about the lowest of any city of equal size in the State, and very much lower than in most of them.

The council has added during the year 114 arc lights, 84 electroliers and 20 incandescent lights in different parts of the city. The price of arc lights has been reduced from \$6.00 per month to \$4.50 per month. About one-third more has been expended in cleaning streets than during the previous year.



## EXAMINATION OF ACCOUNTS

Pursuant to section 24 of the charter, directing the mayor to employ a certified public accountant, I retained Mr. John F. Forbes, who is a member of the State Board of Accountants, to examine at the end of December and June, the books, records and reports of the auditor and all officers and employees who receive or disburse city moneys and to make reports as required by charter.

While I think the system of accounting employed by the auditor is as satisfactory as could be devised, there may be some room for improvement in the methods used in the various departments, by introducing a more uniform system to be observed by all such officers.

## THE METHOD OF MAKING PURCHASES

A large part of the revenue of the city, outside of the salary roll is expended in the purchase of supplies. One of the administrative departments under the new charter is the department of public supplies and the commissioner thereof is practically the purchasing agent of the city. The auditor's statement submitted each month shows the expenditures in the various departments. The head of the department is expected to submit an estimate each month to the commissioner of finance and revenue, of the expenditures likely to be needed and if approved by the council it is authorized and the purchases are made as required within the limit, and beyond it in cases of emergency. Requisitions against this estimate are drawn by the head of each department on the commissioner of the department, and signed by such commissioner and the commissioner of public supplies. When the receipt of the article is acknowledged by the proper officer, the bills are examined and audited by the commissioner of finance and revenue and the commissioner of public supplies and the auditor. They are then approved by the council and warrants for the respective amounts signed by the auditor and the city clerk are presented to the mayor for his signature. If claims are presented before Saturday, the warrants are payable on the following Tuesday.

The number of purchases made by the department of public supplies during the year was about twenty-two hundred. The total amount of purchases was \$52,913.35 ranging from penholders to road rollers.

I think the importance of purchasing agent for the city where the supplies amount to such a considerable sum during the year, justifies the provision of the charter making it one of the departments of the government.

*Other Departments.* The commissioner of finance and revenue has supervision of the offices of assessor, treasurer and tax collector and is charged with the duty of preparing the annual estimate of income and expenditures of the city to be submitted to the council. He is a member of the finance committee and approves all claims, and is ex-officio a member of the Board of Education.

The commissioner of public health and safety, besides supervising the general work of the police and fire departments has been active, but at the same time patient, in the enforcement of the sanitary ordinances of the city. In conjunction with the health office, and the police and fire departments, he has in the main induced compliance with these ordinances without resort to harsh means.

## SIDE LIGHTS ON MUNICIPAL ACCOUNTING AND ADMINISTRATION

BY WILLIAM DOLGE, C. P. A., MUNICIPAL ACCOUNTANT, FELLOW AMERICAN ASSOCIATION OF PUBLIC ACCOUNTANTS

In all cities, and particularly in the so-called "dry towns", most of the municipal revenue is derived from taxes levied on real and personal property. There is also more or less revenue from Recorder's Court fines, from leases, from the sale of old material, and from public service utilities operated by the city. With respect to these last, it does not always appear from the accounts whether the utility is actually a money-making proposition for the municipality.

The greatest single source of revenue, after taxes, is licenses. In dry towns the licenses may be as little as 5% of the total revenue, although the amount is usually a greater one. In other cities, the revenue derived from licenses will vary from 20 to 40 and even 50% of the total revenue. As a revenue producer, the license on the sale of liquor undoubtedly stands at the head. It is an open question whether the cost of the protection of life and property, i. e. Police and Fire Departments, grows in the ratio of the increase of license revenues derived from sale of liquor.

While no hard and fast rule will apply to each case, yet it may be said that the revenues from liquor licenses should be sufficient to cover the entire cost of the protection of life and property, or in the larger cities, at least the entire cost of operating the Police Department.

Where the liquor license rate is high, there is always a greater or less sale of liquors without the payment of the regular license fee. The city trustees may have indirect knowledge of this condition of affairs, but are rarely able to get the necessary legal evidence to punish offenders. Trustees naturally are disinclined to proceed in person against any citizen, as this is the official duty of the peace officer—the Marshal. It is a curious commentary upon modern municipal conditions that the Marshal is frequently unable to procure evidence of violation of the liquor license laws, even though he and his deputies are on duty every day. This coupled with the fact that the Deputy United States International Revenue Collectors visit the district a few times a year and succeed in locating every establishment where malt or spirituous liquors are sold, makes the Marshal's apparent dereliction of duty all the more striking. It may be safely said that there is no good reason for the continued violation of a liquor ordinance, if the trustees and the Marshal really desire to stamp out illicit traffic. Probably the best reason that the Federal Government succeeds in collecting all its revenue licenses lies in the fact that punishment for the violation of the Federal Laws is swift and sure.

Of the revenues derived from licenses, the liquor license ordinance usually produces from 40 to 70% of the total, leaving a very appreciable balance from 30 to 60% to be derived from other licenses. In charter cities some classes of business are exempt, but in municipalities of the fifth and sixth class any business may be taxed. There are many theories of taxation and the problem of the support of the government has always been the most serious one that the administrators and legislators have had to solve. A tax is defensible only upon the ground that the revenue is needed for the support of the government, and a tax upon business in addition to a tax upon real and personal property is defensible only because the tax upon property is insufficient to meet the governmental expenses. Exception

may be made of the tax which is exacted as a penalty or compensation of a special privilege and which is levied as much for the purpose of regulation as for the purpose of raising revenue. A license tax upon business should be equitable, and it seems to the writer that this can only be accomplished by a classification of the kinds of business and a grading according to the volume of business done. In other words, an income tax, which shall fall heaviest upon the ones best able to bear the burden. It is meet that amusements of all descriptions be taxed to produce a license revenue and heavier than other established businesses, because the purveyor of amusement can more easily pass the tax to the "ultimate consumer", than can the business man engaged in mercantile pursuits. Some consideration should be had of the amount invested and of the taxes that are paid upon real and personal property in determining the rate for any particular class of license. Where businesses are subject to license it seems but fair to local merchants that they shall be protected in so far as possible against the sale of merchandise from without the city. In this case the license ordinance is in the nature of a tariff wall, and while it is not proper nor advisable entirely to exclude pedlers, solicitors, etc., yet it would appear to be good administrative policy to levy licenses, which discourage indiscriminate competition with established local business.

In most municipalities the license ordinances do not cover all classes of remunerative occupations, that might properly be made the subject of a license tax. Without consideration of merchants there follows here a list of businesses and so forth which it is believed include practically all occupations legally subject to license taxes in municipalities of the State of California:

Academies, riding, dancing, roller-skating, etc.; advertising signs and sign painters; agencies, railroad, stage and steamship; agents, express and transfer; agencies, mercantile and collection; agents, soliciting; agents, real estate and insurance; apartment houses; assayers; astrologers; automobiles, passenger for hire; auctioneers; balls, masked; ball or ring throwing games; ballrooms; bankers; baseball grounds; bathing establishments; bill posters; billiard tables; boarding houses; boats; bootblack stands; bowling alleys; boxing or sparring exhibitions; beating carpets; brokers, custom house; brokers, merchandise; brokers, house; brokers, stock; carpet beating and cleaning; cars, railroad, freight and dirt; cars, street railroad, passenger; caterers; chaffeurs; circus; clairvoyants; concealed weapons; cycleries; cycloramas; delivery companies; dogs; dyeing and cleaning works; electric light and power companies; employment agencies, house-cleaning companies; exhibitions; express agents; flower pedlers; fortune tellers; gas companies; gas regulator companies; guides; gunpowder; hacks; halls, public; hotels; house-raising or moving; insurance companies, solicitors and adjusters; intelligence offices; junk dealers; laundries; laundry offices; liquor dealers; livery stables; lodging houses; mediums; merchandise brokers; nickel-in-the-slot machines; panoramas; park, outdoor; passenger vehicles; pawnbrokers; pedlers, flower and other articles; pedlers, general; pedlers, railroad tickets; petroleum, storage of; pool rooms; runners and solificing agents; phonograph parlors; race courses; refiners of metals; scavenger wagons; second-hand goods, etc.; shooting galleries; shows; skating rinks; slaughterers of live stock; smelters; solicitors of street work; stables, boarding; solicitors, insurance; street car advertising; supplying vessels with sailors, etc.; telephone companies; tenement houses; theaters; theater ticket selling; towel companies; transfer and delivery companies; trucks and wagons; vehicles, passenger; warehouses; water companies; vending machines.



## ACCOUNTING OF LICENSES

The law provides for a license register which is in effect the book of original entry and charge to the License Collector of the licenses delivered to him. The accounting is exceedingly simple: the clerk charges the License Collector with the licenses delivered, and credits the License Collector with the amounts deposited in the City Treasury. The License Collector is responsible for the difference between the amount total of the licenses delivered to him and the amounts total deposited in the City Treasury. The difficulties and the dangers are in connection with the form of the license certificate and the license certificate stub-book. To maintain an individual account with each licensee would involve an extraordinary amount of labor for the clerk, and in itself this would be no safeguard should the clerk be in collusion with the License Collector. Usually many occupations or undertakings properly subject to license tax escape the same; Sometimes by collusion with the License Collector, or with the Clerk, or with both, but more frequently as a result of the imperfect system and the absence of the licensee's name from the license book. Cases have been known where carelessly written licenses were raised by dishonest License Collectors from \$1.00 to \$4.00, from \$2.00 to \$5.00 and to \$10.00, the difference going into the pocket of the License Collector has failed to report changed conditions, demanding an increased license fee, to his own and the licensee's pecuniary advantage. All this could be obviated with an improved form of license certificate and license certificate stub-book, which combines in itself an automatic follow up, and by the receipt vouchers deposited with the Treasurer, an absolutely true record of the amount collected.

Few cities have taken advantage of different colors of paper to indicate without close examination the period for which the license is issued, and still fewer have realized that vehicle licenses, dog licenses, slot machine licenses, and all other licenses requiring tags, may be controlled in a much more rigid, inexpensive and simple manner than is the common practice.



## THE NEXT CONVENTION (Continued)

November 15, 16, 17 18, and 19 at San Diego

Immediately preceding the next convention of the League, a City Planning Conference will be held in Los Angeles under the auspices of the Municipal Reference Bureau of that city. The date is set for November 14th, 15th, and 16th, making it possible for delegates on their way to San Diego to stop off in Los Angeles and take part in the conference. A printed prospectus has this to say:

"Cities in every land are interested in the subject of city planning. Two national conferences have been held in this country. Several societies have been organized which are nation wide. Many cities have adopted plans furnished by experts. No city, however small, can afford to neglect to plan definitely for its enlargement along proper lines. In the southwest it is possible to develop a distinctive type of city. We love the open air and sunshine, the broad spaces, the flowers and fruits, and mission style of architecture. The closely built up city is not to our liking. We wish to ruralize the city and forever bar the tenement house. Garden villages are better than slums.

To prepare such a plan for our southwest cities, you are asked to co-operate

in this city planning conference by attending the sessions, by taking part in the discussions, or by furnishing an exhibit. The conference will last for three days, having three daily sessions, with papers read by experts."

It is advisable that all city officials who can spare the time, should attend this conference before proceeding to San Diego.

The program for our next convention is now in process of arrangement. In the department of Clerks, Auditors and Assessors, the following gentlemen will deliver addresses, as follows:

"*Clerk's duties*", by W. E. Parker, who, for many years and until quite recently, was clerk of Monterey. In recognition of his experience and knowledge of municipal government, Mr. Parker recently received the highest vote of the fifteen freeholders selected to frame a new charter for Monterey.

"*Auditor's duties, records, forms and maps*", by D. D. Kellogg, Auditor and Assessor of Pasadena. Mr. Kellogg recently devised a new form of assessment book for which he has been highly complimented by his fellow-officials in Pasadena.

The committee appointed last year to draft an act to provide a uniform system of reports, will be expected to submit a proposed measure for indorsement. This matter is far more important than it would seem at first glance. In order to make reliable comparisons of the growth and development of the various cities and towns, it is absolutely necessary to have a uniform system of accounting and reporting. Without such a system it is practically impossible to tell which municipalities are being most economically governed. At present, each town has a different method of segregating the funds. Under a uniform system, the cost of maintaining the fire department, police department, health department, and other departments of municipal government could be readily ascertained and compared. A vigorous effort should be made to secure the passage of a suitable act by the next legislature.

In the department of City Attorneys, Mr. Charles N. Kirkbride of San Mateo will deliver an address on "*The Framing of Municipal Charters*". Mr. Kirkbride has been City Attorney of San Mateo for many years and is an enthusiastic member of the league. He is regarded as a high authority on municipal corporation law and his address is sure to be both interesting and instructive.

Mr. Stephen G. Long, City Attorney of Long Beach, will go on the program. His subject will be "*The Conservation of Municipal Water Front*". This question has been a live issue in Long Beach recently and Attorney Long has been required to give it a great amount of investigation and study. Therefore his address is sure to be valuable as well as interesting.

The department of City Engineers will be in charge of Chairman S. J. Van Ornum, engineer of Pasadena, and secretary Orlin Hudson of Richmond.

Among the features already selected for this department will be a talk on "*Cement and Cement Testing*" by Wm. B. Gester of Robert W. Hunt & Co., a firm that stands at the top of the engineering profession and has offices all over the world. Mr. Gester is a specialist on Portland cement.

Another interesting number will be a talk on "*Auxiliary Salt Water Fire Fighting Systems*", by Assistant City Engineer Brown of Oakland. The subject should be of particular interest to those cities lying adjacent to salt water.

Oakland installed an auxiliary system of this character within the past year, and it has already demonstrated its efficiency on several occasions, besides bringing about a reduction of insurance rates.

"*San Diego's Water System*" will be the title of an address by Mr. Emory Smith, a specialist on chemical inspection and engineering. Notwithstanding the fact that San Diego lies in one of the most arid regions of the country, the price of water is very low, Mr. Smith was employed as consulting engineer in the construction of this water system and his address should prove interesting and instructive.

At the last meeting in Santa Cruz, a committee of five engineers was appointed to investigate the matter of preparing standard specifications for constructing oil macadam pavement that would answer for all parts of the state. The committee is now working on the report and will have it ready for presentation at San Diego.

As for the program for the entire body, meeting as a whole, there will be among others the following numbers:

"*How the Commission Plan of Government Works in San Diego*", by Hon. A. E. Dodson. This subject is bound to provoke considerable discussion, and Mr. Donson will probably be called upon to answer a great many questions.

Mr. William K. White, of Miller and White, Patent Lawyers, with offices in New York and San Francisco, will talk on the "*Cameron Septic Tank Litigation.*" Miller and White is the firm employed to represent the League in this litigation which is now before the United States Supreme Court.

"*Municipal Accounting*", will form the title of an illustrated talk by Mr. William Dolge, C. P. A. and a specialist on municipal accounting systems. Mr. Dolge will illustrate his talk by throwing on a screen, forms of warrant books, assessment books, tax receipts, etc. He is very much interested in the work of bringing about a uniform system of accounting and has volunteered to assist the committee appointed on this matter and give them the benefit of his knowledge and experience.

Another feature which should prove of special interest will be an address by Mr. Dana W. Bartlett of Los Angeles, on "*City Planning*". Mr. Bartlett is superintendent of the Municipal Reference Bureau of Los Angeles and has given the subject of city planning a great deal of study. He has a very fine set of slides showing what has been done in other cities, with which he will illustrate his address. He will also give a report of the first city planning conference, which will be held in Los Angeles November 14th, 15th, and 16th, just preceding the meeting of the league thus enabling delegates to attend both conventions.

Mr. J. H. Reed, the well-known Tree Warden of Riverside is expected to be on hand and tell the delegates how they made such a success of ornamental tree planting on the streets of Riverside. Stereoptican views will show what has been accomplished there and Mr. Reed will tell how it may be done in any other city or town. The title of his address will be "*Ornamental Tree Planting on Streets and Highways.*"

The Public Health section will be presided over by Dr. W. F. Snow, Secretary of the State Board of Health. An elaborate program is being arranged for this department. Within the past few months, under direction of the board, a quiet inspection has been made of the sanitary conditions in nearly every city and town in the state. Wherever unsanitary conditions were found, photographs were taken and slides made. These pictures will be thrown upon the screen and the delegates advised as to the proper remedies. In addition to these views, Dr. Snow has procured two reels of moving pictures, one illustrating the fly evil and its results, and the other showing the proper and improper methods of conducting



dairies and handling milk. The speakers of this department will be announced in the October number. In all probability, the illustrated lectures will be made before the entire convention and not confined to the health department alone.

### QUESTIONS FOR DISCUSSION

In addition to the set speeches, there are several questions of general interest which will undoubtedly come up for discussion and action; for instance, there is the Warren Brothers patent pavement. Santa Ana was recently notified that certain specifications adopted there would be considered an infringement. Since then, Palo Alto received a similar warning. Many attorneys are of the opinion that the Warren Brothers Company are making claims to which they are not entitled and the opinion is expressed that the claims should be contested.

Another matter of importance is the suggested modification of the Vrooman Act. It is generally conceded that this act should be simplified without creating new openings for more litigation.

The Municipal Convention and Exposition to be held in Chicago next year is still another matter to be taken up. The League has been requested officially to participate in this convention, the invitation received being under the signature of the Mayor of Chicago and the president of the Chamber of Commerce.

At the Santa Cruz Convention the department of City Attorneys recommended a change in the constitution of the League to provide for a better plan of united action in matter of litigation. For example, suppose it was decided to contest the Warren Brothers patent. Here is something in which all the cities are naturally interested, therefore the expense of litigation should be borne jointly in proportion to population.

Then there is the question of water-rights, and although San Francisco, Madera and Imperial are the only cities particularly interested at present, the issue involved concerns the rights of every other municipality.

Again there is the litigation with the telephone companies. These people claim the right to erect poles in the streets of any municipality without a franchise. That claim is disputed, and Los Angeles, Pomona, Riverside and Pasadena have joined together to contest these claims of the telephone companies. But why should these four cities alone shoulder the expense of the litigation? Every city in the state is interested in the decision and (in proportion to its size) will reap the same benefits. Therefore it is desirable to try and arrange some plan whereby we can secure the co-operation of all the municipalities, where they are concerned in the litigation.

### THE EXHIBITION

Following the example set by the League of American Municipalities at the recent St. Paul Convention, there will be an exhibition of municipal machinery and supplies in connection with our San Diego meeting. A separate hall will be secured for exhibition purposes and an opportunity given to the various exhibitors to demonstrate their goods and machinery. There will be quite a number of exhibits of pavement construction, voting machines, garbage incinerators, sanitary fountains, motor fire engines, etc.

The League of California Municipalities is destined to be a great factor in the development and improvement of the cities of this state. Those that have neglected to join our organization and send delegates to our convention do not realize what they are missing, and poor indeed is the municipality that cannot afford

membership in the League. The fact that there are now twenty-two states in the union having these organizations, is pretty good proof of their value.

The coming meeting at San Diego has every promise of being the greatest assemblage of its kind ever held in California. The program being arranged speaks for itself. Let us hope that every city in the league will have at least one delegate in attendance; but send more if possible. The clerks and auditors should attend this meeting, also the health officers. Do not hesitate to pay the expenses of a few of your officials; it is an investment that will repay you many times over.

A convention of the league is no picnic or junketing trip, as those who attend regularly will testify. The delegates will be called upon to devote all their time to business, during the day. Suitable entertainment for the evening is being planned by the city officials or San Diego.



## CORONA GRAMMAR SCHOOL

SOUTHWEST CONTRACTOR AND MANUFACTURER

Some new and very interesting features have been worked out by Archt. Leo Kroonen of Corona in planning the proposed new grade school to be erected in Corona. The exterior is designed in the so-called Mission style. Altho nominally

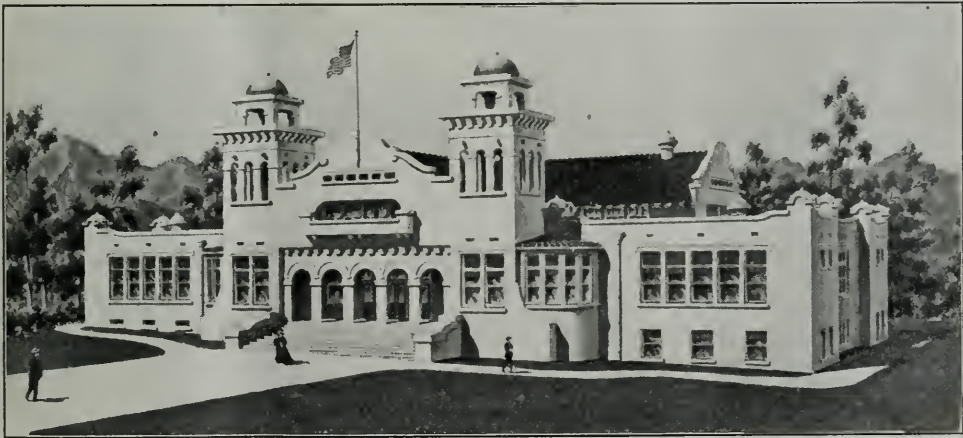

PERSPECTIVE OF CORONA GRAMMAR SCHOOL BUILDING  
Lee Kroonen, Corona, Architect

a one-story and basement building, it will have more the appearance of a two-story and basement structure. In order to obviate the "squatty" effect so common to one-story buildings covering a large ground area, the architect has carried up the central portion and main front to practically two stories and enhanced the general effect as to height by means of towers.

The building will have a frontage of 162 feet and an extreme depth of 100 feet. In the center of the structure will be a large assembly hall, 100x37 feet, around which will be ranged the eight class rooms, sewing room, cooking room, and principal's and teachers' rooms, all on the main floor. The ceiling of the assembly hall will be 22 feet 6 inches high, carrying that section of the building

above the one story portion containing the class rooms. The main front between two towers will extend to the same height as the assembly hall and both will be covered with a peaked roof. There will be a flat roof over all the class rooms.

Some very important advantages are gained by the general floor arrangement. The assembly hall is, in reality, only an enclosed court and thereby serves a double purpose. In the walls of this section extending above the flat roof is a row of swinging windows ranging all the way around the hall. These windows, which will be glazed with ribbed glass, will furnish ample light and ventilation.

In this connection it is well to say that special attention has been given to the ventilation of the whole building. There will be four globe ventilators in the flat roof over the class rooms and two in the roof over the assembly hall. There will also be 36 openings between the ceilings in the various rooms and the roof for the circulation of air. This elaborate system of ventilation, which has all been worked out on scientific lines, is expected to keep the building cool in the hottest weather.

The basement will contain the sloyd room, two rooms which will not be finished at present, but which may be used for classes, boys and girls' lavatories and toilets, janitor's room and place for heating plant. In the main front on the second floor will be a library 29x38 feet, connected by an open arch with a balcony overlooking the assembly hall. There will be a balcony, 40x60 feet, on the main front, on a level with the library floor.

The front entrance to the building is through an 18 foot corridor leading to the assembly hall. There is also a rear entrance to the main floor and the basement, and stairways at either end of the assembly hall gives access to the basement.

In point of construction the building will be first-class. The concrete foundation will extend to the first-story joists and the super structure will be frame with exterior walls plastered on an extended metal lath. The flat roof will be covered with composition and the pitched roof with Spanish metal tile. The interior walls and ceilings will be given a sand finish with hardwall plaster, tinted, and there will be a smooth finished cement wainscot, painted, in all rooms, halls and corridors. The interior woodwork will be slash grained Oregon pine and there will be double floors deadened with surfaced pine tops. A plenum system of heating will be installed.

Bonds to the amount of \$25,000 were issued for the erection and equipment of the building. Bids for the construction were opened August 27th.



## THE WARREN PATENT

---

In the May number will be found an article under the title of "Oil macadam and Bitulithic Pavement", referring to the possibility of oil macadam being an infringement of the Warren patent. A letter from the Warren Brothers Company was set forth in the article, together with extracts from the decision of Judge Lurten which was rendered January 5, 1909, in the case of Warren Brothers Company vs. City of Owoso, wherein the claims of the company were upheld. It appears from the company's letter that they consider oil macadam might be an infringement of their patent.



About ten months ago specifications were prepared and adopted for street improvements in Santa Ana. When the trustees were about to proceed with the work, they suddenly received a formal notification from the Warren Brothers Company that a pavement laid under the specifications they had adopted would constitute an infringement.

Within the past few weeks, the officials of Palo Alto were the recipients of a similar notice. The objectionable specifications adopted by Palo Alto are as follows:

#### ASPHALT CONCRETE PAVEMENT

"Upon the sub-grade shall be constructed an asphalt concrete pavement as hereinafter specified not less than four (4) inches in thickness after final compression, which shall be composed of gravel or broken rock (crusher run) the maximum size to pass through a two and one-half ( $2\frac{1}{2}$ ) inch ring, clean, sharp sand and asphalt cement. Not less than ten (10) pounds of asphalt cement to the cubic foot of stone and sand shall be used and as much more as the character of the stone and sand may require in order to bind the particles of stone and sand together in a homogeneous or solid mass after final compression.

The asphaltic mastic shall be heated to not more than three hundred (300) degrees Fahr. before mixing with the broken rock or gravel. The broken rock or gravel to be heated in suitable dryers to a temperature between two hundred seventy-five (275) and three hundred (300) degrees Fahrenheit.

The mixing of all ingredients is then to continue within the temperature limits above indicated until every particle of the sand and broken rock or gravel is thoroughly coated with the asphaltic cement. When thus prepared it shall be delivered upon the works at a temperature of not less than two hundred fifty (250) nor more than three hundred (300) degrees Fahr., and shall be immediately spread on the subgrade previously prepared:

The top of the asphalt-concrete shall consist of a paint coat of liquid asphalt not more than ( $\frac{1}{2}$ ) gallon per square yard. This liquid asphalt to be heated to at least one hundred fifty (150) degrees Fahr. and spread uniformly. Liquid asphalt must be a refined residuum Petroleum Oil and must contain not less than 85% bitumen soluble in chloroform. A coat of sand to be spread over this liquid asphalt coat immediately in thin layer, and rolled with a roller weighing not less than five (5) tons."

This pavement is also known as asphalt macadam. It is alleged that several pieces of street work, under very similar specifications, were constructed in San Francisco long before the Warren patent was issued. It is claimed also, that substantially the same kind of pavement is being laid to-day in that city, for which no royalty is demanded.

Therefore there is a great deal of doubt as to just what the Warren patent covers.

City Attorneys who contemplate attending the San Diego convention are requested to give the matter a little investigation, in order that they may be thoroughly informed when the matter comes up for discussion. The case of Warren Brothers Company vs. City of Owoso is reported in 166 Fed. Rep., p. 309.

## PACIFIC MUNICIPALITIES

## WARREN BROTHERS DEFEATED

Word has just been received of a favorable decision for the defendant, by the U. S. Circuit Court for the Southern District of Iowa, in the case of Warren Brothers vs. the City of Creston, Iowa. The advance sheets of the Federal Reporter, containing the decision in full, will be out within the next few weeks.



## DUES RECEIVED

Dues for the past month have been received as follows:

Alhambra	\$30 00	Oceanside	10 00
Biggs	10 00	Oroville	30 00
Bishop	18 00	Pacific Grove	20 00
Coronado	10 00	Piedmont	20 00
Elsinore	10 00	Red Bluff	20 00
Etna	10 00	Richmond	20 00
Eureka	30 00	Santa Ana	30 00
Ft. Jones	10 00	San Luis Obispo	20 00
Gilroy	20 00	Santa Paula	10 00
Hercules	20 00	Sebastopol	10 00
Lakeport	10 00	Sonoma	10 00
Lompoc	40 00	St. Helena	20 00
Los Banos	10 00	Vacaville (2 yrs.)	40 00
Martinez	20 00	Yreka	20 00
Newport	10 00	Willets	10 00



## QUESTIONS AND ANSWERS

Q.—May a water company take up its pipes and quit serving the town, at its pleasure?

Ans.—No.

Q.—Dear Sir:

There is a man in Livermore selling aluminum kitchen ware. His modus operandi is to call upon a housewife with a sample of his wares from which he makes his sales. He represents that the goods are manufactured in Pittsburg and that he will make delivery as soon as the goods can be received from the factory. It is probable that he gets them from some state agent in San Francisco. When approached for a license he tells the same story and declares that he is exempt.

What is the legal status of this case? Can a municipal license be collected from this man under the circumstances? Such cases come up several times a year. Sometimes the Marshal bluffs them into paying but oftener they show fight and are allowed to go. He would like to be sure of his ground and know exactly what to do with these cases as they present themselves.

Ans.—Dear Sir:

Replying to your inquiry of September 19th, will say that the

right to collect a license tax from peddlers depends upon certain finely drawn conditions.

For instance, if he is an employee of a house of another state, under salary or commission, he is not subject to license under the Iner-state Commerce Law, whether he delivers the goods himself or has them delivered direct.

If, however, he first purchases the goods outright from the Pittsburg house and they become his property, he is subject to license tax. If he represents a San Francisco agent he is subject to licence tax. (See Pacific Municipalities for June, 1910, page 180.

Q.—How shall we go about fixing water rates in the case where a company has just installed a water system and no customers have been procured yet. The trustees want to put in hydrants but cannot afford to pay the price asked by the company. Can they refuse to supply us for fire purposes?

Ans.—Replying to yours of Sept. 2nd will say that the authority given cities of the 6th class to regulate water rates is laid down in the Constitution of California in Art. X, Sec. 19, and Art. XIV, Sec I.

The powers are more particularly defined in Sections 548 and 549 of the Civil Code, and 4410 and 4412 of the Political Code; and again in Act 4348 of the General Laws.

It is declared that the rates must be reasonable and this is sometimes a pretty hard matter to determine. It is up to the trustees to fix the rates, not the water company. The average charge for hydrant service is about from 1.00 to 2.00 per month. You should find out what other nearby cities are paying and fix your rates accordingly, for the time being at least.

The company cannot refuse to serve you with water for domestic and fire purposes. Look up the sections of the constitution referred to.



## ITEMS OF INTEREST

---

**Automobile Fire Apparatus.** Many inquiries are received at the office of the League regarding motor fire engines. For the benefit of those interested we have been informed that Long Beach, Pomona, Whittier and San Diego have Rambler machines, while Redlands, Riverside, Pasadena and Los Angeles have the Seagrave machine.

**How Wide Should a Street be?** In an article by the editor of the Municipal Engineering Magazine (Feb. 1910), he says: "The general concensus of opinion is that the roadway should be narrowed to correspond with the traffic over them. The business streets and those with street railway tracks may need 40 to 48 foot driveways, and main lines of travel into the residence district or out to main country roads without street car tracks, need 30 to 40 foot driveways. The average residence street has no use for a paved roadway more than 24 to 40 feet wide.

"The breadth of view which is claimed as one of the beauties of wide streets is not interfered with by narrowing the roadway, while the near view of grass, flowers, shrubs and trees is much more acceptable than the bare basement.

"The narrow streets are also far more sanitary. All dirt and slush dries up on the pavement and blows about as dust into houses, vehicles and persons pass-



ing, but there are none on the grass plots. The narrow pavements are much easier and cheaper to clean and to keep sprinkled, if this treatment is followed, and they are farther from the houses, so that the unsanitary conditions are less pronounced as well as more easily removed.

"Trees grow better on the wider grass plots and their number may perhaps be materially increased. Their shade as well as the less area of sun reflecting on hard pavements diminish the temperature, thus adding greatly to comfort.

"Then the pavement of the roadway costs less in proportion to its area, and a reduction of a third in width means a reduction of a third in costs.

"The uselessness of a wide pavement, the waste of money in building it, the beauty of the area not paved, which can be obtained for the cost of maintaining the pavement, are unanswerable arguments."

In the *Municipal Journal and Engineer* (Oct. 1909) is the following regarding Coronado City, California:

"In this city the roadways are in general 48 feet between curbs, but it is proposed to make them 32 feet wide, the present 16-foot sidewalk being increased to 24, a considerable portion of which will be improved by grass plots and trees.

Reference is made to several instances of narrow streets in other cities, as follows: Prairie Avenue, Cottage Avenue and several millionaire residence streets in Chicago are 30-foot streets. Kansas City's residence portion has miles of similar narrower and parked streets, making an impressive effect as cool shady avenues. Sacramento, Woodland, Chico and even San Diego, have adopted this sensible plan for residence streets."

(It is understood that in this quotation the word "street" refers to the roadway only, or the distance between curbs.)

"A resident of Sacramento states that he spent some time with a tape on the streets of Seattle and found most of the roadways of the residential streets to be only 24 feet wide, some of the newer streets being only 20 feet. One street in the best residential section was 26 feet between curbs and had six-foot stretches of parking through the center of this space, leaving only ten-foot roadways on either side. These streets are paved with asphalt."

New York City has adopted a rule for the width of streets fixing 30 feet as a minimum width where there is a single track street car line and 40 feet for a double tracked street. In streets from 60 to 66 $\frac{2}{3}$  feet in width between property lines the width between curbs is fixed at one-half the total width.

Pasadena regulates the width of roadway in proportion to the length of the street, 65-foot streets to 1500 feet in length being fixed at 30 feet, from 1500 to 3000 in length the width is 32 feet and from 3000 to 5000 in length the width is increased to 34 feet.

The citizens on some of the streets in Visalia, if the same are paved, will ask that the board of trustees fix by ordinance a sidewalk width of 15 feet, leaving 36 feet between curbing, or ten feet less than at present.—Visalia Delta.

**Greater Care of Health.** At the conference of 42 mayors of New York State it was decided that the thing most needed was that public health work should occupy a more prominent place in municipal affairs.

**City Wins Water Case.** A telegram from R. E. Rhodes, who went to Los Angeles Saturday, brought the best of news to Maderans. Mr. Rhodes stated that the water case was decided this morning by Judge Welborn of the United States District Court in favor of Madera.

When the City of Madera voted bonds to provide for the installation of a

municipal water system the Madera Water Company brought suit to restrain the city from entering into competition with the system, alleging that a municipality had no constitutional right to engage in the service in competition with an established tax paying corporation of the city, to whom the city had granted a franchise.

The council engaged in the case were City Attorney Rhodes and Frank Short and McCutcheon, Page and Knight for the Water Company?

Percy V. Long of San Francisco also wrote a brief in the case for San Francisco, as the case would affect that city's right to construct the Hetch Hetchy Valley system.

While the plaintiff's attorneys have intimated that the case would be carried to the United States Supreme Court in case of an adverse decision the fact that there are numerous decisions in the east holding in favor of the municipalities' right to install water and lighting systems, where no exclusive franchise had been granted to individuals or corporations, it is believed Judge Welborn's decision will be accepted as final.

**Injunction Saves Town's Water Supply.** Had not the city attorney of Morgan Hill succeeded in securing an injunction against the Morgan Hill Water Company in Judge Gosbey's Court yesterday, the people of that town might be without water for domestic purposes.

Over three years ago an agreement was made by the town of Morgan Hill and the water company, by the terms of which the company was to supply water for the town and its inhabitants at a certain rate. The corporation recently decided to increase the rate named and the city dads objected. The company threatened to shut off the supply of water, and attorney G. K. Estes, representing the town, immediately got busy and secured the injunction restraining the company from so doing. The injunction will remain in force until the matter is finally settled.

**Death Loss Reduced.** From all quarters of the country reports have come to Chicago indicating that the "rational Fourth" movement was widespread in its observance. In Chicago one death was reported during the day—a sacrifice to a stray bullet. Returns from the outside showed twelve victims of the sporadic manifestations of the old noisy Fourth, with its dynamite and its toy pistol carnage. With the deaths reported previously, the total sacrifice of life during the two days' celebration to midnight of the Fourth ran up to eighteen.

When compared with the figures of former year's necrology gives a great ground for jubilation. One year ago the total deaths that had been reported by July 6th was 155, as compared with 18 this year. Two years ago in 1908, the list of killed numbered 72.

The total injured throughout the country reported up to midnight of the Fourth was 743. One year ago the number tabulated on July 6th, after three days of celebrating, was 2387. Two years ago the number reported on July 6th was 2438.

**Chemical Engine Saves Fine Home.** The fire department responded to a fire alarm from the new home of D. C. Leffertas on Highland avenue near Smiley Heights, Saturday afternoon about 5:25 o'clock. Material left by carpenters on the second floor of the new home is supposed to have caught fire by spontaneous combustion and when the department arrived a fairly good blaze was burning.

The chemicals were used to extinguish the flames and it was only the work of a few minutes to get the beautiful new house out of danger. While the dam-

age was not great the heavy oak floor, which is being used in the house, was burned and scorched to such an extent that it will probably have to be replaced. It was only the space of a few minutes from the time alarm was turned in until the fire was out.

This is the first real test that has been made in the city of the efficiency of the big auto fire engine and there is no doubt now but that the move made by the trustees in buying it was a wise one. The big engine took the Cajon street grade like a thing of life and many precious minutes were saved that would have meant much damage to the beautiful residence. This is the first call in the city limits that the big engine has answered.

The run was a long one and the time made by the big engine on the steep grades was a real test of what it can do. A large crowd followed the engine on its trip up Cajon street, but most of them were soon left behind.—Redlands Review

**Must Pay License.** That the ordinance of the town of St. Helena, which imposes a license tax upon persons engaged in the practice of medicine within the town, is valid, is the decision of the Supreme Court of the State of California—the court of last resort in this matter.

This case, which has attracted wide-spread attention among members of the medical profession throughout the state, as well as officials of incorporated towns, had its origin in the refusal of Dr. D. E. Osborn, Dr. F. C. Newton and Dr. J. H. O'Connor to pay a license tax of \$3.00 per quarter imposed by Ordinance No. 208, passed by the Board of Trustees of St. Helena about a year ago.

The doctors were arrested in November 1909. They retained Attorney Theodore A. Bell.

The case was heard by Town Recorder J. G. Johnson, January 15th, and the defendants were found guilty and fined \$10 each.

The town was represented in those and subsequent proceedings by Attorney James A. Nowland.

The case was then appealed to the Superior Court and on May 15th was argued before Judge Gesford, who gave judgment in favor of the town.

The next step on the part of Attorney Bell was to take the matter to the Appellate Court on a petition for a writ of habeas corpus.

In that court the doctors met the same fate.

As a last resort Mr. Bell then took his case to the Supreme Court on similar proceedings, and the petition was denied without argument on the part of counsel.

This last decision settles the matter so far as the courts are concerned, although it is understood that the State Medical Society will endeavor to have the next Legislature amend the law relating to the powers of incorporated towns so as to exempt physicians from the imposition of license taxes.

The three physicians who were the defendants in this case will now be called upon to turn into the town treasury back license taxes and fines amounting to \$81.



## What the Cities are Doing

**Porterville** claims to be leading all the other cities in Tulare County in new buildings.

**Monrovia** will build a new grammar school.

**Grass Valley** has ordered the printing of 5000 advertising pamphlets; they will be profusely illustrated.

**Sebastopol** is now supplied with gas; the main runs from Santa Rosa, seven miles away.

**Santa Cruz** citizens have petitioned for a new charter.

**Palo Alto** is one of the leading cities in Santa Clara County in the matter of good streets and sidewalks.

**Corning** trustees are considering a bond issue for water works and a sewer system.

**Alameda** is building several new schools.

**Claremont** received bids on September 17, for an auto combination chemical engine.

**Pasadena** recently saved \$12000 on re-advertising for bids on storm sewers.

**Santa Barbara** decides by a six to one vote to issue \$200,000 additional bonds to complete its new water system.

**Sacramento** trustees are considering the purchase of auto fire apparatus.

**Napa** talks of installing a garbage incinerator.

**Stockton** wants motor fire apparatus. A recent disastrous fire has shown the necessity of modern equipment.

**Alhambra** will install a new system of municipal accounting.

**Long Beach** citizens are circulating petitions for a municipal water system.

**Orange** votes \$16,000 for sewers and \$5000 for paving the plaza.

**Santa Monica** will publish an advertising booklet, the leading citizens being requested to contribute \$100 each.

**Coalinga** is to have a public park. The city furnishes the land and the fire department will improve it.

**Willows** is awarded \$10,000 by Andrew Carnegie for a library. The money was procured through the efforts of the Woman's Improvement Club.

**Hayward** will pave five miles of streets at an expense of \$250,000. Asphalt macadam will be used.

**Redding** intends to purchase an auto fire cart.

**Pacific Grove** has received plans of a handsome high school building from Architect W. H. Weeks, the well known specialist in public buildings.

**San Jose** wants a garbage incinerator.

**Woodland** has plans for an auxiliary water-works plant.

**Modesto** will install improvements to their water works plant.

**Visalia** has ordered the construction of more asphalt macadam streets.

**Redlands** is about to install a system of ornamental street lighting.

**Palo Alto** has been notified by the Warren Brothers Company that the specifications adopted by the council, infringe on their patent.

**Pasadena** is planning to build a fine bridge over the Arroyo.

**Red Bluff** will install a sanitary drinking fountain.

**San Leandro** has been offered a sanitary drinking fountain by one of its public spirited citizens.

**Livermore** is considering the installation of a municipal water plant.

**Vallejo** votes \$80,000 bonds for improving the water system. The bonds carried by 567 against 87.

**Monterey** will vote on a bond issue of \$8000 for constructing a waterway through Caledonia Park.

**Alturas** is considering two municipal improvements of importance—a municipal water plant and a sewer system.

**Placerville** will soon start on the erection of a new court house.

**Monrovia**, on October 14, will vote on a bond issue of \$120,000 for a sewer system and \$50,000 for extending the water system.

**Martinez** is considering a bond issue of \$100,000 for developing the water front, constructing a salt water fire fighting system and erecting a new city hall.

**Palo Alto** contemplates a bond issue for an auto fire engine, a park and a permanent building for the power plant.

**Monterey** received bids on Sept 20, for a sewage disposal tank.

**Crescent City** intends to purchase some improved fire apparatus in the near future.

**Placerville** trustees are considering the installation of an electric fire alarm system.

**Sonoma** has obtained over \$500 premium on its \$20,000 5 per cent sewer bonds.

**Alameda** is thinking of installing an auxiliary fire-fighting system.

**Willows** will vote on the question of issuing \$25,000 bonds for City Hall, \$5,000 for city hall site, and \$10,000 for new fire engine and apparatus.

**Ontario** is considering the purchase of a chemical engine.

**Hanford** is considering the extension of its sewer system. City Engineer Jensen of Fresno has been consulted.

**Monrovia** has sold its \$125,000 high school bonds for a premium of \$5,225. The bonds carry five per cent interest.

**Long Beach** is about to start on the erection of the new Polytechnic High School.

**Roseville** sold its \$78,500 5 per cent sewer bonds at par. A better offer was expected, but there was but one bid.

**Mountain View** contemplates extensive street improvements.

**San Mateo** has voted bonds for sewers, fire department, bridges and street work.

**Oceanside** votes \$20,000 bonds for repair and improvement of the water system.

**Martinez** is considering the installation of a new water plant.

**Redlands** and **San Bernardino** are discussing plans for the construction of a joint municipal electric light plant.

**Lodi's** new water system, costing \$150,000 is about completed.

**King City** wants to be incorporated.

**Stockton** will vote on fifteen proposed amendments to the charter, which if carried will establish the commission plan of government.

**San Anselmo** trustees are thinking of putting on the lid.

**Santa Barbara** Chamber of Commerce is agitating for the establishment of the commission plan of government.

**Alhambra** may incorporate as a city of the fifth class.

**San Bernardino** has let a contract for the installation of the Gamewell Fire Alarm System.

**Colusa** citizens are much pleased with the new city waterworks.

**Salinas** has a contest on hand regarding the validity of their license ordinance relating to bill boards. The contestant claims the license is prohibitive.

**Santa Monica** has repealed its dog muzzling ordinance.

**Chico's** \$150,000 municipal improvement bond issue has been declared valid.

**Long Beach** Press is advocating the abolishment of the ward system in that city.

**Glendale's** municipal lighting plant is proving a great success. Forty candle power tungsten lamps set in enameled reflectors, are used for street lighting.

**Benicia** is putting down several miles of oil macadam pavement.

**Richmond** is having a remarkable growth. The S. F. Chronicle says: "The phenomenal growth of Richmond is of especial value because it is entirely based on industry. Industries make the great cities, and not trading, and it is in industries that California has always been weak.

Consequently the rise of this new city among us is of the utmost value, not only to those who happened to own the land on which Richmond is being built, but to Berkeley, Oakland, Alameda, and more than all, to San Francisco."

**Santa Clara** has a lawsuit brought against the city for the return of a contractor's deposit. The contractor backed out of his contract and wants his deposit returned.

**Whittier** has let a contract for a \$9000 addition to the High School to be occupied by the manual training department, and is receiving bids for the erection of a \$50,000 polytechnic high school.

**Ocean Park** Trustees are considering granting a fifteen year liquor license to the proposed new \$200,000 hotel.

**Visalia** is to pave thirty-two blocks of its business streets with asphaltum.

**Yreka** is putting in cement sidewalks and a new steel bridge. A public library has been established and a new city hall is in contemplation.

**Venice** is to remain open all winter and plans are being made for a series of carnivals and fiestas to be held during the winter months.

**Ontario** has an assessed valuation of \$2,384,137, an increase of \$300,000 for the year.

**South Pasadena** has just completed a new \$35,000 school.

**Biggs** is considering the installation of a sewer system. Engineer Hazelwood of San Francisco has been consulted.

**Los Angeles.** Under a recently adopted ordinance the Police Commission has ruled that Los Angeles saloons must have a clear-glass front and glass doors and no screens, so that any passer by may view the interior. The commission also decided that free lunches may be served, but the so-called "commercial" lunch was tabooed.

**Pomona.** The members of the Board of City Trustees recently watched the operation of the new suction street sweeper which the city has had on trial for the last thirty days, and expressed themselves as satisfied that the sweeper is doing as good work as could be expected. The machine costs \$1,800 and is the same machine which is in use in Redlands, San Bernardino, Long Beach and several other cities of Southern California. On Second street the machine has not been doing its best work because of the many holes in the paving, and it is not strong enough to draw the dirt out of the holes, but on Third street the dirt is taken up with very little dust. Since the suction sweeper was put in use no sprinkling has been done on any of the paved streets, thereby saving a considerable expense.



**"HYGIENIC" DRINKING FOUNTAIN**

For Schools, Railway Stations, etc. Prevents contagion and provides each user with an ample supply of fresh water.

Illustrated circular sent on request.

The newest things in plumbing fixtures for Schools, Factories and Office Buildings are on display in our Show Rooms.

851-859 Folsom Street, San Francisco, Cal.  
Phones, Sutter 1130; Home J-2110

**Haines, Jones & Cadbury Co.**  
Makers of Plumbing Supplies  
1130-1144 Ridge Avenue, Philadelphia  
Branches—Savannah and San Francisco

F. W. Haselwood, Assoc. M. Am. Soc. C. E.      Sidney Jones      E. W. Doane      W. A. Hanscom

**Haselwood, Jones, Doane & Hanscom**  
*Civil, Hydraulic and Sanitary Engineers*

Sewers, Waterworks, Light Plants, Street Work and Bridges

Phone Sutter 1337      675-677 Monadnock Building      SAN FRANCISCO, CAL.

**E. T. THURSTON, Jr.**

Assoc. M. Am. Soc. C. E.

**Consulting Engineer**

712 Mechanics Institute Building

Phone Kearny 902      SAN FRANCISCO

**Specialties**

Design and Supervision of Buildings, Bridges, Railways, Water Works and Municipal Work

**Concrete Bridges**

Exclusive rights under patents of National Bridge Company, the largest in the world.

Estimates furnished free of charge.

**C. A. BLUME CONSTRUCTION CO.**

Members of Builders Exchange

**Structural Steel Riggers**

Phone Douglas 324  
185 STEVENSON STREET

SAN FRANCISCO

**W. N. CONCANON CO.**

**Constructing Engineers**

Foundations, Reinforced Concrete, Steel and Concrete Buildings and Bridges  
General Engineering Work. Special Attention Given to Public Work

433-437 Monadnock Bldg.      Phone Kearny 2884.      681 Market St-      SAN FRANCISCO, CAL.



## LIST OF RESPONSIBLE FIRMS TO BE CALLED ON TO BID FOR PUBLIC WORK OR SUPPLIES

### WRITE FOR CATALOGS

This list is arranged as a guide for the accommodation of city officials where advertising for bids is not necessary.

- Accountant**  
William Dolge, C. P. A., 255 California St., S. F.
- Architects**  
W. H. Weeks, 251 Kearney St., S. F.
- Asphalt Machinery**  
A. L. Young M'chy Co. 26-28 Fremont St., S. F.
- Arch. Terra Cotta**  
Gladding, McBean & Co., Crocker Building, S. F.
- Automobile Public Service Wagons**  
Consolidated Motor Car Co., Cor. Van Ness and McAllister Sts., S. F.  
The Thomas B. Jeffery Co., 117-125 Valencia St., S. F.
- Bitulithic Pavement**  
Warren Brothers Company, Los Angeles, Cal.
- Bridge Builders**  
Keatinge-Bradford Co., 615 Humboldt Bk Bdg.  
E. T. Thurston, Jr., Wells, Fargo Bldg., S. F.
- Concrete Construction**  
Keatinge-Bradford Co., 615 Humboldt Bk Bdg.  
Hazelwood, Jones, Doane & Hanscom, 675 Monadnock Building, S. F.
- Contractors and Builders**  
Finch Jail Building and Metal Co., 16 California St., S. F.
- Constructing Engineers**  
Fred'k C. Roberts & Co., 221 Sheldon Building, S. F.  
Standard Engineering Co., 503 Market St., S. F.  
W. N. Concannon Co., 433-437 Monadnock Building, S. F.
- Consulting Engineers**  
Spaulding, Sloan & Robson, 802 Union Trust Building, San Francisco.
- Drinking Fountains**  
Haines, Jones & Cadbury Co., 851-859 Folsom St., S. F.
- Dump Carts and Wagons**  
A. L. Young M'chy Co., 26-28 Fremont St., S. F.
- Electrical Plants & Machinery**  
A. L. Young M'chy Co., Fremont St., S. F.  
Chas. L. Kiewert Co., 195 Fremont St., S. F.  
Standard Engineering Co., 503 Market St., S. F.
- Engravers and Bond Printers**  
Commercial Art Co., 53 Third St., S. F.  
Schmidt Lithograph Company, Second & Bryant Sts., S. F.  
Sierra Art Engraving Co., Front & Commercial Sts., S. F.
- Fire Alarm and Police Tel. Systems**  
Gamewell Fire Alarm Tel. Co., Market and Battery Sts., S. F.
- Fire Dept. Equipment**  
Cal. Fire Apparatus Co., Jessie and New Anthony, S. F.  
R. S. Chapman, 400 Golden Gate Ave., S. F.
- Fire Engines**  
Gorham Rubber Co., 50-56 Fremont St., S. F.
- Fire Extinguishers**  
Goodyear Rubber Co., 589 Market St., S. F.
- Fire Hose**  
Gorham Rubber Co., 50-56 Fremont St., S. F.  
Eureka Fire Hose M'fg Co., 610 Postal Tel. Building, S. F.  
New York Belting & Packing Co., 129-131 First St., S. F.
- Gasoline Engines**  
Doak Gas Engine Co., 7-9 First St., S. F.
- Lithographers**  
Schmidt Lithograph Company, Second & Bryant St., S. F.
- Metal Furniture**  
Finch Jail Building and Metal Co., 16 California St., S. F.  
Art Metal Construction Co., Flood Bldg., S. F. Story Building, Los Angeles.
- Municipal Accountant**  
William Dolge, C. P. A., 255 California St., S. F.
- Municipal Lawyers**  
Mason & Locke, 904 Pacific Building, S. F.
- Municipal Printers**  
A. Carlisle & Co., 251-253 Bush St., S. F.
- Municipal Pumping and Water Service**  
Fredk. C. Roberts & Co., 461 Market St., S. F.  
Standard Engineering Co., 503 Market St., S. F.
- Pavement Materials**  
Warren Brothers Company, Los Angeles, Cal.
- Playground Apparatus**  
A. L. Young Machinery Co., S. F.
- Reinforced Oil Concrete Streets**  
E. M. Chadbourne Co., 800 Postal Tel. Building, S. F.
- Road Machinery**  
J. I. Case Threshing Mch. Co., 616 Myrtle St., Oakland, Cal.  
Henshaw, Bulkeley & Co., Fremont St., S. F.  
A. L. Young M'chy Co., Fremont St., S. F.  
Petrolithic Pav. Co., 209 E. 7th St. Los Angeles
- Safes**  
Cary Safe Co., 669-671 Mission St., S. F.  
Parcells Safe Co., 577 Market St., S. F.  
Victor Safe & Lock Co., 1292-4 Market St. S. F.
- Scrapers**  
A. L. Young M'chy Co., Fremont St., S. F.  
Petrolithic Pav. Co., 209 E. 7th St., Los Angeles.
- Sewer Pipe and Terra Cotta**  
Gladding, McBean & Co., Crocker B'ldg, S. F.  
Steiger Terra Cotta Co., Mills B'ldg., S. F.
- Street Signs**  
A. L. Young Mch. Co., S. F.
- Street Sweepers**  
A. L. Young M'chy Co., Fremont St., S. F.
- Structural Steel Riggers**  
C. A. Blume Construction Co., 185 Stevenson St., S. F.
- Vaults**  
Cary Safe Co., 669-671 Mission St., S. F.  
Parcells Safe Co., 577 Market St., S. F.  
Victor Safe & Lock Co., 1292-4 Market St., S. F.
- Water Supply**  
Doak Gas Engine Co., 7 and 9 First St., S. F.

**WILLIAM DOLGE**

*Certified Public Accountant --:-- Municipal Accountant*

TELEPHONE DOUGLAS 5173

255 California Street

San Francisco, Cal.

**WM. H. WEEKS, Architect**

PUBLIC BUILDINGS A SPECIALTY

251 Kearney Street

San Francisco

**SPALDING, SLOAN & ROBSON**  
CONSULTING ENGINEERS

Waterworks, Sewer Systems, Paving, Lighting Plants

Telephone Kearney 4646

802 Union Trust Building, SAN FRANCISCO

Chas. P. Bradford, President

M. Keatinge, Vice-Pres. and Supt.

Howard J. Van Kirk, Secretary

**KEATINGE-BRADFORD COMPANY**

Concrete Contractors and General Contractors

Telephone, Kearny 2921

Room 615 Humboldt Bank Building

SAN FRANCISCO

**GORHAM RUBBER CO.**

RUBBER GOODS OF EVERY DESCRIPTION

Fire Hose, Chemical Engines, Hose Carts, Packing

**50-56 Fremont St., San Francisco**

W. J. LOCKE

H. A. MASON

**Mason & Locke**

ATTORNEYS AND COUNSELORS AT LAW

*Bond proceedings conducted---validity and sale guaranteed*

Ninth Floor Pacific Building

SAN FRANCISCO

The  
Bitulithic  
Pavement  
For Streets  
and Roads



1 Mile	7 Cities
22 Miles	33 "
52 "	40 "
59 "	45 "
59 "	42 "
85 "	57 "
109 "	66 "
95 "	62 "
118 "	74 "
679 "	216 "

**TOTAL MILES (30 Ft. Road)**

Combines the inherent stability of the mineral aggregate with the cementing qualities of the asphaltic oil, or other bituminous cement, and produces a smooth, dustless, waterproof pavement, suitable for automobile traffic and driving--prevents skidding and affords a good foothold for horses--is COVERED BY PATENTS, the VALIDITY of which has been SUSTAINED BY THE SUPREME COURT OF THE UNITED STATES.

Send for circulars showing where used and methods of construction.

**WARREN BROTHERS COMPANY**

Portland, Ore.

Boston, Mass.

Los Angeles, Cal.  
616 Laughlin Bldg.

REGISTERED TRADE MARKS

"Bitulithic" "Warrenite" "Puritan" "Bitrock" "Bituminous Macadam" "Biustone"

**MAPS**  
**BONDS**  
**STATIONERY**  
**BOOKLETS**  
**POSTERS**  
**LABELS**  
**CARTONS**  
**ETC.**

**SCHMIDT LITHOGRAPH COMPANY**

MAIN OFFICE  
SAN FRANCISCO.

PORTLAND      LOS ANGELES

**FINCH JAIL BUILDING AND METAL CO.**

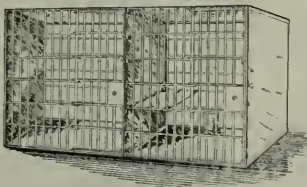

Manufacturers and Builders of

**PRISON CELLS AND ALL APPURTENANCES.**

Dealers in Metal Furniture and Fixtures

Office No. 16 California St.

Telephone Kearney 935



# SPECIAL BARGAINS IN THE BEST MAGAZINES

1. Review of Reviews - - \$3.00 } <b>All For</b>	2. Review of Reviews - \$3.00 } <b>All For</b>
American Magazine - - 1.50 } <b>\$3.25</b>	Woman's Home Companion 1.50 } <b>\$3.50</b>
Sunset Magazine - - 1.50 }	Sunset Magazine - - 1.50 }
3. American Magazine - \$1.50 } <b>Both For</b>	4. Woman's Home Companion \$1.50 } <b>Both For</b>
Sunset Magazine - - 1.50 } <b>\$2.00</b>	Sunset Magazine - - 1.50 } <b>\$2.25</b>
5. American Magazine - \$1.50 } <b>All For</b>	6. Technical World - - \$1.50 } <b>Both For</b>
Woman's Home Companion 1.50 } <b>\$2.75</b>	(or World Today)
Sunset Magazine - - 1.50 }	Sunset Magazine - - 1.50 } <b>\$2.35</b>
7. Forest and Stream - \$3.00 } <b>Both For</b>	8. Van Norden's - - \$1.50 } <b>Both For</b>
Sunset Magazine - - 1.50 } <b>\$3.00</b>	Sunset Magazine - - 1.50 } <b>\$2.00</b>
9. Forest and Stream - \$3.00 } <b>All For</b>	10. American Magazine - \$1.50 } <b>All For</b>
Womans Home Companion 1.50 } <b>\$3.50</b>	Technical World - - 1.50 } <b>\$2.75</b>
Sunset Magazine - - 1.50 }	Sunset Magazine - - 1.50 }
11. Review of Reviews - \$3.00 } <b>All For</b>	12. McClure Magazine - \$1.50 } <b>Both For</b>
Van Norden's Magazine 1.50 } <b>\$3.10</b>	Sunset Magazine - - 1.50 } <b>\$2.35</b>
Sunset Magazine - - 1.50 }	14. Review of Reviews - \$3.00 } <b>At Half Price</b>
13. Scientific American - \$3.00 } <b>Both For</b>	American Magazine - 1.50 } <b>All For</b>
(New subscriptions only)	Woman's Home Companion 1.50 } <b>All For</b>
Sunset Magazine - - 1.50 } <b>\$3.00</b>	Technical World - - 1.50 } <b>\$5.25</b>
	Van Norden's Magazine 1.50 }
	Sunset Magazine - - 1.50 }

## Sunset Magazine, \$1.50 the Year

CLUBS may be split to go to different addresses.

FREE with each order, two beautiful four color pictures of Yosemite Valley, ("El Capitan" and "Vernal Falls") handsomely mounted. These pictures will be sent flat, not rolled.

POSTAGE to Canada is 50 cents extra on each magazine; to foreign countries is \$1.00 extra.

### SUNSET MAGAZINE FOR 1910 INCLUDES

- (1) A California novel "The Rules of the Game" by Stewart Edward White—to be run as a serial.
  - (2) Mexico Today—a series of articles of great interest, by one high in authority in our sister republic.
  - (3) Alaska and the Alaskans, by Governor Walter E. Clark.
  - (4) The best fiction by such authors as Jack London, Billie Glynn, Eleanor Gates, Dave Coolidge, James Hamilton Osborne, etc.
- And many other special features.

ADDRESS

## SUNSET MAGAZINE

313 Battery Street

San Francisco

# MUNICIPAL AND CONTRACTORS' MACHINERY

...FOR...

## GOOD ROADS AND STREETS

Street Signs  
National Road Machines  
Fort Wayne Road Machines  
Indiana Road Machines  
National Elevating Graders  
Elevators—Portable Bunkers  
Shares or Cutting Edges for all types of Road Machines  
Rock Crushers, Jaw and Gyratory Type, mounted and unmounted



Screens  
Steam Road Rollers  
Horse Rollers  
Scarifiers  
Harrows for oiled roads  
Wheeled and Drag Scrapers  
Fresno Scrapers  
Reversible Road Plows  
Street Sprinklers  
Sprinkling Attachments  
Street Sweepers  
Fibre for Street Sweepers  
Patent Dump Wagons  
Asphalt Machinery  
Kettles—Hand Rollers—Tampers  
Concrete Mixers  
Hoisting Engines  
Playground Apparatus  
Culvert Pipe

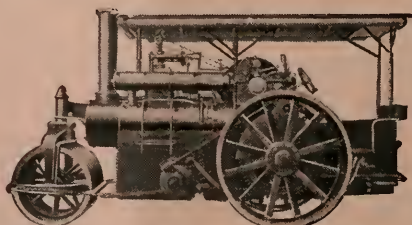

Write us for Catalogues and Estimates

## A. L. Young Machinery Co.

26-28 Fremont Street

San Francisco

California

# Pacific Municipalities



SAN DIEGO  
CALIFORNIA.

## PUBLISHED MONTHLY

OFFICIAL ORGAN OF THE LEAGUE OF CALIFORNIA MUNICIPALITIES



## ROAD MEN NEED THESE IMPLEMENTS

*A very successful street superintendent writes:*

"Having used the **Gang Rooter Plow** for several months to break up street surfaces, either oiled or natural, I take pleasure in recommending the same, and our experience has been that the work can be done at much less cost than by the old method of plowing the streets. I also take pleasure in recommending the **Spike Disc Harrow** for pulverizing rough plowed streets or for breaking up oiled surfaces that have become rough by buckling. *After oiled streets have been spiked and smoothed up and rolled the result is often a much better road than when the oiling was first done.*"

SEND FOR CATALOG.

## PETROLITHIC PAVEMENT CO.

336 Pacific Electric Bldg., Los Angeles, Cal.

### SILENT

### LUXURIOUS

### 3 MODELS

THE NEW  
*Rambler*

Touring Cars, Motor Fire Trucks, Chemical, Hose, Police, Patrol and Ambulances a Specialty.

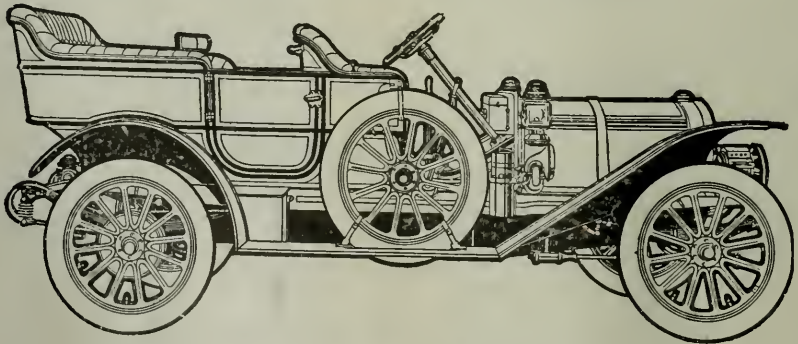

### The Thomas B. Jeffery Co.

117-125 Valencia St.

WRITE FOR INFORMATION.

San Francisco

PACIFIC MUNICIPALITIES

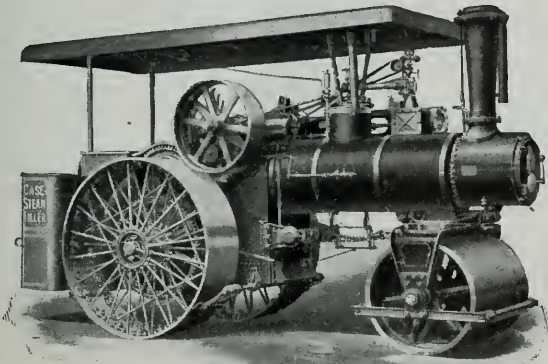

# CASE

36 Horse Power

10 Ton Road Roller

Time Price--with Simple Cylinder

**\$2,200**

with Compound Cylinder

**\$2,300**

6 per cent Discount for Cash.

**The Only Spring-Mounted Road Roller Built**

CASE Rollers have greater fuel and water carrying capacity than others

We sell the well known line of **TROY Dump Wagons and Dump Boxes**  
and a full line of road building machinery.

Road Rollers—Catalog 36. Contractors' General Purposes Engine and Municipal Tractor—  
Catalog 37. Address Road Machinery Dep't.

**J. I. CASE THRESHING MACHINE COMPANY, Inc.** RACINE, WIS.,  
U. S. A.

BRANCH OFFICE, 616 MYRTLE ST., OAKLAND, CAL.

Insure your Valuable  
Papers with

## Parcells Safe Co.

AGENTS

**"Diebold" Safes and "Allsteel" Metal Furniture**

577 MARKET STREET

SAN FRANCISCO

## A. CARLISLE & CO.

**Stationers, Printers and Bookbinders**

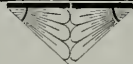

We specialize in Bonds, Steel Die, Lithographed or Printed, for  
Municipalities or Counties, and the Books and Forms  
required by all Municipal Officers.

251-253 Bush Street

San Francisco, Cal.

# LEAGUE OF CALIFORNIA MUNICIPALITIES

Organized 1897

## — OFFICERS —

President	(Mayor of Riverside)	S. C. EVANS
First Vice-President	(City Clerk of Monterey)	W. E. PARKER
Second Vice-President	(Mayor of Berkeley)	BEVERLY L. HODGHEAD
Secretary	H. A. MASON	Assist. Secretary WM. J. LOCKE

## STANDING COMMITTEES

**EXECUTIVE**—S. C. Evans, President; H. A. Mason, (Sec.) San Francisco; Clinton L. White, Mayor of Sacramento; A. E. Dodson, Councilman, San Diego; H. P. Brainerd, Mayor of Petaluma.  
**LEGISLATIVE**—H. L. Partridge, San Jose; M. J. Rogers, Ventura; Hugh R. Osburn, Santa Cruz; James H. Gray, Santa Rosa; S. G. Long, Long Beach.  
**JUDICIARY**—C. N. Kirkbride, San Mateo; Perry L. Wood, Pasadena; O. G. Hopkins, Sacramento; W. P. Butcher, Santa Barbara; Wallace Rutherford, Napa.  
**ENGINEERING**—W. F. McClure, Berkeley; H. B. Kitchner, Watsonville; Orlin Hudson, Richmond; C. P. Jensen, Fresno; S. J. Van Ornum, Pasadena.

Secretary's Office and Headquarters of the League, - Pacific Building, San Francisco

## INFORMATION BUREAU

The League of California Municipalities maintains, in connection with the Secretary's Office, an Information Bureau where the officials of the municipalities belonging to the League can secure information on all subjects relating to municipal affairs.

## MEMBERSHIP

Alameda	Lompoc	San Buenaventura
Alhambra	Long Beach	San Diego
Anaheim	Los Angeles	San Francisco
Antioch	Los Banos	San Jose
Auburn	Los Gatos	San Leandro
Benicia	Loyalton	San Luis Obispo
Berkeley	Madera	San Mateo
Biggs	Martinez	San Rafael
Bishop	Merced	Santa Ana
Black Diamond	Mill Valley	Santa Barbara
Burlingame	Modesto	Santa Clara
Calistoga	Monterey	Santa Cruz
Chico	Mountain View	Santa Maria
Coalinga	Napa	Santa Monica
Colusa	Nevada City	Santa Paula
Coronado	Newman	Santa Rosa
Corona	Newport Beach	Sausalito
Covina	Oakland	Sebastopol
Crescent City	Oceanside	Selma
East San Jose	Orange	Sierra Madre
Elsinore	Oroville	Sisson
Emeryville	Oxnard	Sonoma
Escondido	Pacific Grove	Sonora
Etna	Palo Alto	South Pasadena
Eureka	Pasadena	South San Francisco
Fairfield	Petaluma	St. Helena
Ferndale	Piedmont	Stockton
Fort Jones	Pinole	Suisun City
Fresno	Placerville	Susanville
Gilroy	Pleasanton	Tehachapi
Glendale	Point Arena	Tulare
Hanford	Pomona	Vacaville
Hayward	Red Bluff	Vallejo
Hercules	Redding	Visalia
Hermosa Beach	Redlands	Watsonville
Huntington Park	Redondo Beach	Whittier
Imperial	Redwood City	Willits
Jackson	Richmond	Winters
Lakeport	Rio Vista	Woodland
Lemoore	Riverside	Yreka
Livermore	Sacramento	
Lodi	San Bernardino	

Every city belonging to the League of California Municipalities is entitled to a free copy of this magazine every month for each of its officials; if not received kindly notify the Secretary.

**See that your City is in the above list.**



NOTE—Every city official in California reads Pacific Municipalities.

# Pacific Municipalities

OFFICIAL ORGAN OF THE LEAGUE OF CALIFORNIA MUNICIPALITIES

Entered at Post Office, Santa Clara, Cal., as Second-Class Matter

VOL. XXIII

TWELFTH YEAR

No. 3

EDITORS - - - H. A. MASON AND WM. J. LOCKE  
EDITORIAL OFFICE - NINTH FLOOR, PACIFIC BLD'G, SAN FRANCISCO  
PUBLICATION OFFICE, - - - SANTA CLARA, CALIFORNIA

## CONTENTS FOR OCTOBER, 1910

### SAN DIEGO-CORONADO EDITION

Invitation	68
Invitation from State Board of Health	69
Program for City Planning Conference	70
The League of California Municipalities, its Origin and its Work <i>W. J. Locke</i>	71
The Approaching Convention at San Diego	73
Hon. Grant Conard, Mayor of San Diego	79
The Municipal Achievements of San Diego <i>Hon. Grant Conard, Mayor</i>	80
Department of Finance <i>Percival E. Woods, Supt. Dept. of Ways and Means</i>	95
San Diego Water System	102
San Diego Parks <i>Thomas O' Halloran</i>	108
The Nolen Plans for the Improvement of San Diego <i>Julius Wangenheim</i>	111
San Diego, its Advantages from a Climatic and Hygienic Standpoint <i>Francis H. Mead, M. D.</i>	114
The Land of Cool Summers and Warm Winters <i>Ford A. Carpenter</i>	115
Good Roads for San Diego and its Vicinity <i>A. G. Spalding</i>	117
San Diego <i>Rufus Choate, Secretary Chamber of Commerce</i>	119
San Diego Has Many Fine Churches	125
San Diego Harbor	128
La Jolla	136
City of Coronado <i>Geo. Holmes, President of Board of Trustees</i>	140
Panama-California Exposition <i>Winfield Hogaboon</i>	143
Municipal Milk for Babies <i>Milo Hastings</i>	148
Sanitation in South American Cities <i>Mrs. Percy Jackson</i>	149
Items of Interest	151
Questions and Answers	152
What the Cities are Doing	155

Published Monthly. Yearly Subscription, \$2.00 in Advance. Single Copies, 25 Cents

#### ADVERTISING RATES ON APPLICATION

Address all Communications to "PACIFIC MUNICIPALITIES" Pacific Building  
San Francisco, California

# *The City of San Diego*

*and the*

## *League of California Municipalities*

*join in extending to*

### *Every Mayor*

*every Councilman and every Department Head*

*of every City in the Pacific Coast States, a*

### *Cordial Invitation*

*to attend the sessions of the Thirteenth Annual Convention  
of the League in*

## *San Diego*

*November 15th, 16th, 17th, 18th and 19th, 1910*

*and to enjoy the hospitality and entertainment extended by the Mayor and the Common  
Council, aided by the Chamber of Commerce, business  
men and citizens of San Diego*

*The Convention will be held at the  
U. S. Grant Hotel*

# CALIFORNIA STATE BOARD OF HEALTH

## OFFICE OF THE SECRETARY

TO COUNTY SUPERVISORS AND CITY BOARDS OF  
TRUSTEES OF CALIFORNIA

The California State Board of Health requests your participation in a conference on health administration to be held in San Diego November 16-19, 1910.

The League of California Municipalities meets in San Diego at this time, and will send out an invitation to all cities in the League to send their various city officials to this convention as delegates. You are familiar with the good results which have followed the past conventions of this League, and it is hoped that even greater progress in developing policies of economy and efficiency in municipal administration will follow this meeting. The State Board of Health has decided to issue a call for a joint conference of county and city health officials to be held simultaneously with the League meeting. The program will cover four days, November 16th to 19th, inclusive, and will be devoted to such questions as the following:

1. Standard regulations for quarantine.
2. What diseases must be reported.
3. Duties of physicians to the public and to the health officer in matters of public health.
4. Methods of garbage disposal in cities and on the farm.
5. Reciprocity between the city and county boards of health in controlling milk, vegetable and meat supplies.
6. What deaths should require postmortem examinations and coroner's inquests.
7. Needed public health legislation.

Every Trustee or Supervisor knows many instances in which needless expense and much friction have been caused by disagreement of county and city health officers over questions of quarantine or other public health matters. The State Board of Health believes that their attention needs only to be called to this Conference to elicit approval of sending delegates from their respective sections of the State. If each Board of Trustees and Supervisors would assume the traveling expense of its delegates, the Conference would be assured of full representation from the entire State, and correspondingly greater efficiency in its work.

The State Board, therefore, urgently recommends that each county and city in California be represented by at least one delegate to the Conference of California Health Officers.

By order of the Board:

Respectfully submitted,

WILLIAM F. SNOW,  
Secretary

NOTE—A railroad rate of one and one-third is available for those attending this conference.



# MUNICIPAL REFERENCE BUREAU

LOS ANGELES, CALIFORNIA

OCTOBER 26, 1910

W. J. LOCKE,

ASSISTANT SECRETARY LEAGUE OF CALIFORNIA MUNICIPALITIES,  
SUITE 804 PACIFIC BUILDING SAN FRANCISCO.

DEAR SIR:

The following is the provisional program for the City Planning Conference meeting at 618 New High Street, Los Angeles, November 14th to 16th, 1910:

City Planning, its history and future.

The work of the House Commission.

Municipal Housing a possibility.

Congestion through Immigration, how met.

Inexpensive sanitary houses for workingmen.

Garden Villages.

Industrial Districts.

Making the Harbor beautiful?

City Planning from the standpoint of the Landscape Architect.

City Planning from the standpoint of the Architect.

Making a City Beautiful.

Metropolitan Park System.

Playgrounds.

Trees of a City

The relation of the Improvement Association to City Planning.

Planning for Music and Art in the Greater City.

Means of Communication and Transportation—Subways.

Changes necessary in laws and ordinances—Excess Condemnation.

Adequate Income.

Many of the above subjects will be illustrated by stereopticon. Opportunity will be given for liberal discussion.

Yours very truly,

DANA W. BARTLETT.

# PACIFIC MUNICIPALITIES

▲ Journal for Progressive Cities

VOL. XXIII

OCTOBER 31, 1910

No. 3

## THE LEAGUE OF CALIFORNIA MUNICIPALITIES, ITS ORIGIN AND ITS WORK

**O**NE day in December, 1898, a handful of men assembled in San Francisco, at the instance of Ex-Mayor Druffel of Santa Clara and Mr. H. A. Mason, the present secretary, and formed the organization that has since proved to be such a great factor in the progress of California's cities and towns.

There were twenty-eight delegates in attendance at that first meeting, representing thirteen municipalities, including Berkeley, Merced, San Mateo, Nevada City, Santa Barbara, Santa Clara, Salinas and Modesto. It was presided over by Hon. Jas. D. Phelan, then Mayor of San Francisco.

The League of American Municipalities had recently come into existence and many officials readily saw the advantages which would be derived from the formation of an organization of this character. The expense of sending delegates to national conventions was too much for small municipalities however, consequently membership in the American League appealed only to the larger cities. Therefore when the suggestion was made to form a state organization it met with enthusiastic support from the first. Before calling the first meeting, letters were sent out to the various cities and towns asking for opinions on the value of such an organization and, without exception, all the responses were favorable.

Since then, annual conventions have been held and a great amount of work accomplished looking to the improvement of cities. Prior to the formation of the league no record was kept of municipal work. Every city was in the dark as to what the others were doing. There was no stimulus to do very much. With the organization of the league all this was changed. An official organ was published and reports made of municipal improvements under way or in contemplation. Further stimulus was added by the discussions that took place at the annual meetings. New life was injected into the cities and towns and a strong demand for improvements was manifested. Sewers were put in and streets were paved. The official records showed that the towns that were best improved, were the ones that increased fastest in population.

The league took a hand also in initiating new legislation and many important measures beneficial to municipalities, were placed upon the statute books. Among other things, was an amendment to the law relating to the right of cities and counties to impose licenses; the amendment enabled the cities to obtain considerably

more revenue than formerly. The municipal bond act was another measure in which the league played a large part. Still another, was the act exempting municipal bonds from taxation.

"The league acts as a clearing house of ideas and experiences", says Mayor Hodghead of Berkeley. Any experiments tried by one municipality are carefully watched and the results noted, in order that the other cities and towns may profit by their success or failure. Many thousands of dollars have been saved as a result of this one feature.

The use of septic tanks for disposing of sewage was first introduced by the league. Another question of momentous importance that has been given a great deal of attention by the league, is the use of crude oil in the construction of streets and roads. As a result it is conceded that we know more about oil roads in California than anywhere else in the Union.

At the present time a great amount of attention is being devoted by the leading officials and members of the league to city charters and the improvement of municipal government.

The league maintains headquarters in the Pacific Building, San Francisco, adjacent to the magnificent law library of the San Francisco Bar Association, of which association several of the officers are members. One of the many benefits accruing to the small cities and towns, from membership in the league, is found in the "information bureau" or "question box". All questions sent to headquarters, legal and otherwise, are promptly answered. Many towns will testify to the advantages of this feature.

The league welcomes new members. We have a strong organization as it stands at present, but it is desirable that every incorporated city and town in the state should belong. Much important litigation will be taken up in the next legislature, and the cities of California by unity and co-operation can secure almost any reasonable legislation they ask for.



## RAILROAD TICKETS

---

Railroad tickets to San Diego may be procured from any ticket agent, at any time after November 5th, and the ticket for the return trip must be used by November 30th. Purchasers may procure through tickets to San Diego, or one ticket to Los Angeles on the Southern Pacific and another from there on the Santa Fe. Do not fail to procure the return certificate from the agent in all cases.



## NOTICE TO DELEGATES AND EXHIBITORS

---

Our publicity manager, Mr. J. F. Selig, will be in San Diego from the 5th day of November on, and will be glad to make all reservations for our delegates and exhibitors. Address all communications to

J. F. SELIG  
U. S. Grant Hotel, San Diego, Cal.



## THE APPROACHING CONVENTION AT SAN DIEGO

**J**UDGING from the interest manifested and the excellent program that has been prepared, the approaching convention at San Diego in every respect, will far surpass all its predecessors. Officials of our cities and towns are beginning to realize the immense amount of valuable knowledge that may be gained from these annual gatherings. The instinctive desire to grow and improve exists in communities as well as in individuals, and no place can advance intelligently and economically unless it keeps a close watch on the doings of other communities and profits by their experiences.

How much money has been wasted on useless experiments? There are many cases on record where towns have spent thousands of dollars on new fangled methods or machinery or supplies, that others had tried and found poor or worthless.

Most of these experiences might have been avoided had sufficient investigation been made before investing. For instance, had these towns belonged to the league, an inquiry sent to its headquarters would have put them in immediate possession of a vast amount of information on the particular subject relating to municipal affairs, in which they were then interested. There is not the remotest doubt but what the league has been the means of saving hundreds of thousands of dollars to the cities and towns of our state, and for this reason every municipality in the state should be a member of the organization and send delegates to the annual meetings. A street superintendent of one of our coast towns was once asked if he could recall any particular instance where the league had been of direct benefit to him. By way of reply, he told the following story: "In several places in our town we have encountered quick sand in laying sewers and we were put to a great deal of trouble and expense. I happened to mention the matter at one of our league meetings and received information and advice on the matter from the engineers present, which has since enabled me to save hundreds of dollars to our town."

Twenty-two states in the Union have organized leagues. Isn't that pretty good proof of their value? The last to organize was the state of New York. The largest league is in Iowa, which has a membership of three hundred and fifty cities and towns. Our league has a membership of one hundred and twenty-four out of the one hundred and ninety-seven incorporated cities of California. We want the remaining seventy-three to come in with us now and see what splendid work we are doing.

During the past week invitations were mailed from the league headquarters to all towns in the state. Officials of the leading cities of Washington, Oregon and Arizona have also been invited to attend the convention as spectators and guests.

The convention will be called to order promptly at two o'clock p. m. on the afternoon of Tuesday, November 15th, by the President of the league, Hon. S. C. Evans, Mayor of Riverside. Mayor Conard of San Diego will then deliver an address of welcome, which will be responded to by Past President A. R. Orr, Mayor of Visalia. The secretary will then render his annual report, after which the delegates will be called upon for a general report of the progress of their respective cities during the past year. In the evening there will be a smoker attended with impromptu entertainment in order that the delegates may become well acquainted..

## SOME OF THE PROMINENT PARTICIPANTS

## HON. SAMUEL CARY EVANS

Pres. of the League of California Municipalities

The President of the League of California Municipalities was born in Fort Wayne, Indiana, November 22, 1866, and moved to Riverside, Cal., in 1877. He graduated from the University of the Pacific in the class of 1889.

For twelve years Mr. Evans was Secretary of the Riverside School District. In 1907, he was chosen chairman of the Freeholders elected to frame a charter for the City of Riverside, and later, upon the adoption of that charter, he was honored with the office of Mayor.

Mr. Evans is a close student of municipal affairs and has taken active part in the last four sessions of the League of California Municipalities, and also in the League of American Municipalities, holding the distinguished position of Vice-President of the latter body. The city of which he is chief executive, is rapidly becoming one of the leading municipalities of our State.

**William P. Butcher**, City Attorney of Santa Barbara, was elected at the last convention to preside over the Department of City Attorneys. Mr. Butcher has a high opinion of the league. He says:

"Much good has been and much more will be, in my opinion, accomplished by the league. By its meetings the members interchange opinions, ideas and their experiences as city officials, and no one can doubt the benefits derived from such an intercourse. Any one so dense as not to be benefitted by attending one of these meetings certainly is in a very bad way, and is not fit to be an officer of his city."

**Mr. L. M. Hanscom**, City Auditor of Berkeley, was born in the State of Maine and came to California with his parents at the age of eleven. Later, he went east to school and graduated from Phillips Exeter Academy in 1863. He



S. C. EVANS



W. P. BUTCHER, City Attorney, Santa Barbara

matriculated at Harvard College receiving the degree A. B. in 1867.

For a year he was Chief Clerk in the Construction Department at the Navy Yard, Norfolk, Virginia.

In the Spring of 1868, he returned to New Hampshire taking up the study of law.

He moved to the southern part of Oregon in 1873, establishing and editing a newspaper, advocating and securing reforms in county politics. For many years he was a constant contributor to the local and San Francisco newspapers, and always took a lively and active part in municipal affairs.

A new charter for Berkeley was adopted in 1894, framed by a body of freeholders, of which he was one. It went into effect in May, 1895 and he was the first Clerk. From that time, until the present, he has been connected with the city government either as Clerk or Auditor.

He attended as a delegate the meeting at which the League was organized and has been in attendance and has taken a more or less active part in most of the subsequent sessions.



HON. BEVERLY L. HODGHEAD

**Hon. Beverly L. Hodghead** was born near Lexington, Virginia, in 1865, and moved to California at the age of seventeen. He attended the University of California and graduated from the Hastings College of Law in 1891, since which time he has practiced law in San Francisco.

He was a member of the Board of Freeholders which prepared the new charter of Berkeley, and upon its adoption, was elected Mayor.

Berkeley's Charter is regarded by many students of municipal government as the best organic law yet framed, and Mayor Hodghead's address on "The progress of Commission Government" is expected to be very interesting and instructive. His opinion of the league is expressed in the following words:

"The League is a clearing house of ideas and experiences on municipal government. To

it is due] much of the progress the cities of the State have made in the past ten years."





SAMUEL J. VAN ORNUM

William Dolge C. P. A. is a native of New York City, where he spent his early youth. After graduating from public and private schools his preliminary education was completed in 1894 by graduation (honors) from the School of Social Economics, New York. He then became identified with his father's large and varied interests, showing marked aptitude for finances and accounts, and gaining valuable practical experience in mercantile, manufacturing cost and corporation accounting. Due to the farsightedness and generosity of his father, Mr. Dolge was enabled to spend several months of each year in travel in various parts of the United States and in Europe. In 1903 Mr. Dolge came to San Francisco, and in 1905 joined the staff of Lester, Herrick & Herrick, Certified Public Accountants. Appointed general auditors of the San Francisco Relief & Red Cross Funds, popularly known as the "Relief Corporation", Mr. Dolge as-

Samuel J. Van Ornum, born Racine, Wisconsin, April 28, 1880. Moved to Pasadena, California, summer of 1894. Attended public schools and high school at Pasadena, California, graduated from University of California (B. S. in Mechanical Engineering) 1903. In the office of T. D. Allin, Consulting Engineer, and Lippincott and Parker, Consulting Engineers, 1903 to 1905. Deputy City Engineer City of Pasadena, 1905 to 1907. City Engineer City of Pasadena 1907 to present time.

Associate member of American Society of Civil Engineers and member of the Engineers and Architects Association of Southern California.

Mr. Van Ornum says, "The League of California Municipalities can only result in increased efficiency and progress in the civic government of those cities which take an interest and active part in the work of the League."



WILLIAM DOLGE, C. P. A.

sumed entire charge of that important work on behalf of his principals. When the political upheaval in San Francisco occurred in 1907, Mr. Dolge was retained as expert of the Finance Committee of the Board of Supervisors, and so continued until shortly after the recent change in administration. Mr. Dolge is a Fellow of the American Association of Public Accountants, member of the National Municipal League, member California State Society of Certified Public Accountants, and of other State and National societies interested in the advance of government.

**Hugh R. Osborn**, City Attorney of Santa Cruz, has been practicing law in that city for ten years. He was twice elected City Attorney, prior to which he occupied the office of Deputy District Attorney. Mr. Osborn has given considerable study to the Vrooman Act, and will have something to say on that subject at San Diego. Mr. Osborn says:

"Every city and town in the State should have a membership in the League of California Municipalities on account of the mutual benefit and protection it affords."

**A. R. Orr**, former President of League of California Municipalities, and Mayor of Visalia was born in the State of Illinois in the year 1855, and when quite young his parents moved to Missouri where he lived until he came to California in 1875, settling in Visalia where he has ever since resided. In 1876 he established the Visalia Normal, a private school at Visalia which he successfully conducted for a period of eleven years, training teachers and being closely identified with the educational matters of the State. Ill health caused him to quit school work and for eight years thereafter he was connected with the Government Law Office at Visalia as chief clerk therein. Since leaving the Land Office he has had a large practice as Land Attorney and is now engaged in such practice and in looking after his private interests. In the course of his address before the Santa Cruz Convention Mr. Orr said:

"I am sorry for one thing in the State of California—that it is not compulsory for every city in the State to send to a convention like this a representative."

**Mr. D. D. Kellogg**, Assessor of Pasadena, was born in Rutland, Vt., and when ten years of age moved with his parents to Manitowoc, Wisconsin, where until fifteen years of age he attended public school.

In 1862 enlisted in the 1st Wisconsin Cavalry and after an active service of three years in the Civil War was mustered out. Attended High School two terms and Commercial School also two terms.



HUGH R. OSBORN



In 1869 entered the service of a large iron manufacturing firm located in Green Bay, Wisconsin, with branch office in Milwaukee; after one year's service was elected Secretary and Assistant Treasurer, which position he retained for fifteen years. At the same time was Secretary of an Agricultural Implement and Manufacturing Co.

In 1895 on account of failing health moved to California and settled in Pasadena. For 12 years has been employed by the city as Deputy Assessor, and for nearly five years has held the office of City Auditor and Assessor.

He has revised the city's system of assessing and introduced new maps, forms, records, books, etc., making a most complete and up to date system.

During the time that he has been connected with the assessing department of Pasadena the assessment valuations have increased from \$8,300,000 to \$45,000,000.



**MERLE J. ROGERS,**  
City Attorney,  
Ventura, Cal.

**Merle J. Rogers**, City Attorney of Ventura, California, was born in Oregon nearly forty years ago, and has been actively engaged in the practice of law at Ventura since 1900; he has been City Attorney of Ventura since 1903, during which time the city reorganized from an old legislative charter into the fifth class, doubled its territory by annexation; issued and expended the proceeds of \$160,000.00 of bonds for street and other improvements; and has become the best sidewalked and streeted city of its size in the State. Mr. Rogers represented his city at the Sacramento and Santa Cruz sessions of the League of Municipalities, and has taken an active interest and part therein.

Speaking of the League, Mr. Rogers says:

"To the smaller city, the League is of the greatest assistance, both in creating a desire for better things municipal, and in pointing the way to them."

**Percy V. Long**, City Attorney of San Francisco, was born in Sonora, Tuolumne County, March 26th, 1870, and was educated in the public schools of Alameda County. He served as Deputy Clerk of the Superior Court from 1891 to 1895. Was admitted to practice law October 10, 1892. In 1900 he was elected Justice of the Peace of San Francisco. In 1903 he was elected City Attorney and is now serving his third term. His opinion of the League is summed up in the following words:

"The League of California Municipalities is a splendid organization doing a great work in a hitherto very much neglected field. Betterment of municipal conditions is the goal and this organization is leading in the work in this State."



**PERCY V. LONG**

**Mr. George N. Robertson**, who is on the program to deliver an address on the subject, "Reducing the Fire Hazard in Municipalities," will attend the convention as a representative of the Board of Fire Underwriters of the Pacific.

These people know more about fire protection than any other persons or institutions on the coast. It is their particular business to the exclusion of everything else. They are interested in seeing the fire hazard reduced.

We have about ten times as many fires as the older cities of Great Britain and



Europe. There is only one reason for this and it appears to be inexcusable,—we do not go far enough with our building laws, the establishment of fire limits, and the handling and storing of inflammable merchandise, and we are not strict enough with the ordinances now on the books.

A reduction of the fire hazard means a reduction of insurance rates. Mr. Robertson, on behalf of the Fire Underwriters will tell what is necessary for the municipalities to do in order to reduce the hazard. This matter is of vital interest to every citizen in the state.



GRANT CONARD,  
Mayor City of San Diego

## HON. GRANT CONARD, MAYOR OF SAN DIEGO

---

Grant Conard, San Diego's popular Mayor was born on a farm near Ottawa, Illinois, Aug. 5, 1867. He was educated in the public schools of his native state and received his legal education in the Chicago-Kent College of Law. He taught school several years and practiced law five years at Ottawa, Ill. prior to coming to San Diego eight years ago. He has served his City as a member of the Board of Public Works and as director and vice-president of Chamber of Commerce, and took an active interest in introducing the Commission System of government in San Diego and was elected Mayor to inaugurate commission rule in April 1909. He has

represented his city at various conventions such as American League of Municipalities at Montreal last year, where he was elected an officer of the League, and also represented his city and state at Rivers and Harbors and Conservation Congress at Washington. Mayor Conard is recognized as an enthusiastic booster of his city and state and under his administration San Diego is making rapid progress.

Mr. Conard since coming to San Diego has built a beautiful home and has a charming wife and four children. He is engaged in the real estate business and is now erecting a business block at Fifth and C Streets.

## MUNICIPAL ACHIEVEMENTS OF SAN DIEGO

BY GRANT CONARD, MAYOR

THE City of San Diego, the County seat of San Diego County, is located in the extreme southern part of the State of California. It is a seaport city, being pleasantly situated on the shores of the Bay of San Diego, one of the few natural deep water harbors of the Pacific coast. In population it ranks second in Southern California and probably occupies fourth or fifth place among the cities of the State. San Diego is a rapidly growing city, as will appear by figures given elsewhere. The incorporated city covers an area of some 46,000 acres, or more than 72 square miles, extending along the coast some twenty-five miles, and inland from one to five miles. Such suburban towns as La Jolla, Pacific Beach, Ocean Beach and Point Loma are all embraced within the City of San Diego.

### GOVERNMENT

The city is governed under a freeholder's charter. The original charter was adopted in 1889 and provided for a Council of two houses consisting of eighteen delegates and nine aldermen, a mayor, a Board of Public Works, a Police Commission, Fire Commission and various other officials common to that system of government. In 1905 we amended our charter and abolished the two houses and concentrated our council into a body of nine only, one elected from each ward, but we, at that time, retained the ward system and the various commissions. At this time we adopted the Initiative, Referendum and Recall, which provisions are still a part of our charter. In 1909, by a vote of three to one, we amended our charter, taking as our model the Des Moines system, and we now have a Mayor and five Councilmen, nominated at a non partisan primary and elected at large. Candidates for office are nominated by petition and any qualified voter may have his name placed upon the primary ballot upon filing with the City Clerk a proper petition signed by fifty qualified voters. The general election is held two weeks after the primary election, and the two candidates receiving the highest number of votes for each office to be filled at the primary election are the only candidates whose names are permitted on the ballot at the general election, and the candidate receiving the highest number of votes if elected. The adoption of these amendments radically changed our system of government. The Board of Public Works was abolished, the Police Commission and Fire Commission were eliminated and the membership of the Common Council was reduced from nine to five members and each member is superintendent of a department. The Mayor is not a member of the Council but has a general supervision over all departments of the city and it is his duty to see that they are honestly and economically and lawfully conducted. It is his duty to



RESIDENCE OF GRANT CONARD,  
Mayor of San Diego



recommend to the Common Council such measures as he may deem beneficial to the city's interests. He has a veto power and it requires a two-thirds vote to pass any ordinance over the Mayor's veto. The Mayor is chairman of the Auditing Committee and he appoints the Auditor and Assessor, the Park Commissioners, the members of the Board of Health, the Library Trustees and the Cemetery Trustees. All other appointments are made by the Common Council. The authorities and duties of the Common Council are distributed into five departments, as follows:

- Department of Finance, Ways and Means;
- Department of Police, Health and Morals;
- Department of Streets and Public Buildings;
- Department of Fire and Sewers;
- Department of Water.

The new form of government went into effect May 3, 1909, since which time a marked improvement has been made in the management of the city's affairs. The members of the Council now receive a salary of \$2,000.00 per year each, and give their time and attention to the duties of the office, with the result that the city is more economically governed, the laws are better enforced and public business in general is more efficiently transacted than under the former system. The charter provides that the Common Council shall hold regular meetings on Monday of each week, at 10 o'clock, a. m., but the Common Council usually holds one or two other meetings during the week, besides meeting as a Committee of the Whole on Wednesday afternoon at two o'clock.

#### WATER DEPARTMENT

The City of San Diego is fortunate in having within her reach an abundant and wholesome water supply, sufficient to support a city of several times the size of San Diego. The city owns its distributing system, but purchases water from the Southern California Mountain Water Company. The water supply of this company is secured from what is known as the Cottonwood and Otay Water sheds, located in the heart of the mountains of the of the Cuyamaca Range. The water supply is taken from the mountain streams, stored in reservoirs of immense capacity, and is piped to the distributing reservoirs, filtered and aerated before it reaches the consumer. The Chollas reservoir, located some four miles east of the city, has a capacity of eighty million gallons. The Lower Otay reservoir, located some twenty-two miles from the city, has a capacity of 11,696,000,000 gallons, while the Upper Otay reservoir, located some eighteen miles from the city, has a capacity of 653,000,000 gallons. These reservoirs are completed and filled with water.

The Morena reservoir, located some sixty miles from the city, at an elevation of thirty-two hundred feet, is rapidly nearing completion, and has a storage capacity of 15,000,000,000 gallons, and the Barrett reservoir, located ten miles below the Morena, will, when completed, also have a capacity of 15,000,000,000 gallons. Thus it will be seen that San Diego has at her doors the best water system of any municipality in the country.

During the year 1909, the consumption of water was 1,411,380,000 gallons, and there were forty-one miles of new pipe laid, and nine hundred and ninety new taps added. The report of the Superintendent of the Dept. of Water, dated October 10, 1910, given in full herewith, shows what has been accomplished in this department since the first of the year, and the storage capacity of the city reservoirs, and much other valuable information.

CITY OF SAN DIEGO, CALIFORNIA  
WATER DEPARTMENT

OCTOBER 10, 1910

TO THE HONORABLE GRANT CONARD,  
Mayor of the City of San Diego.

*Dear Sir:*

In response to your communication of September 24th, 1910, I have the honor to respectfully submit herewith the following information pertaining to the Water Department:

Since January 1, 1910, this department has laid 1521 feet of 1", 63,634 feet of



A. E. DODSON,  
President Common Council and Supt. Dept. Fire and Sewers  
San Diego, Cal.

2", 6777 feet of 2½" and 665 feet of 3" w. i. pipe; 6302 feet of 4", 7922 feet of 6", 5245 feet of 8", 12,073 feet of 10", 9032 feet of 12" and 1590 feet of 16" c. i. pipe. Total, 20½ miles.

The present improvements under actual construction consist of 1340 feet of 4", 4540 feet of 12" and 2750 feet of 16" c. i. pipe, while pipe purchases of over \$37,000.00 have lately been consummated and the pipe shipped to lay 2400 feet of 8", 20,400 feet of 12" and 2400 feet of 16" mains to replace old pipe prior to the paving of streets in the business sections of the city.

In August, 1910, the citizens of San Diego voted favorably for a \$340,000.00 bond issue for extensions to the present water system and service, covering 94,000







## STREET DEPARTMENT

On account of the vast area embraced within the city, the problem of caring for the streets is a big undertaking. San Diego is fortunate, however, in having near at hand an abundance of good material for road building. The city has some twenty miles of graded boulevards, which have been pronounced by experts to be the finest in the country. These boulevards were constructed of natural earth, and surfaced with disintegrated granite, at a comparatively low cost of construction, and are kept in repair with but little labor and expense. On January 5, 1910, the Mayor in a special message to the Council, recommended the paving of some ten miles of streets, including all the unpaved streets in the business section, extending from Tenth street on the east and B street on the north, to the Bay on the south and west; also a number of the principal residence streets. The Council approved these recommendations of the Mayor, and proceedings are now under way for the paving of these streets, and more streets will be paved this year than ever before in the history of the city.

In caring for the streets of the city, seventy-eight men are employed, sixty-six horses, and twenty-two sprinklers are now in use. There are at present time 14.75 miles of paved streets, and one hundred and four miles of graded streets, over seven miles of which were graded since the first of the year. In addition to this there are over twenty miles of graded boulevards, and the city has over one hundred and twenty miles of sidewalks. At the present time, the Street Department is sprinkling one hundred and forty miles of paved and graded streets, including the boulevards. Since the first of the year, three sanitary flushing machines have been added to the Street Department, which are proving very satisfactory. Much of the street paving is now being done under the ten year bonding plan. The paving of First street, from H street to Laurel street, has just been completed under this plan, at a cost of \$55,221.00.

A year ago the County of San Diego voted \$1,250,000.00 for the construction of four hundred and fifty miles of good roads within the county. The Highway Commissioners are now engaged in building these roads, and a large force of men and teams are at work. On September 15th, forty miles of roads had been graded, and twenty miles surfaced. When these roads are completed, San Diego County will have more miles of good roads than any other county in the United States.

## STREET LIGHTING

Many of San Diego's business streets now have ornamental street lights, installed and paid for by the property owners. The property owners also pay for the cost of lighting for two years. These lights are turned on before dark and burn until midnight. San Diego probably has more miles of ornamental street lights than any other city of its size in the country. D street, which may be called the gateway of our city, is lighted from Arctic street on the west to Eighth street on the east, a distance of nearly a mile. The cost of installing the D street lighting was \$16,460.00 and the cost of the lighting for two years is \$17,263.98, which makes a cost to the property owners of \$2.91 per front foot for installation, and \$3.05 per front foot for lighting for two years. There is a disposition on the part of property owners to install ornamental lights and within a very short time many other streets will have ornamental lighting.

In addition to D street the following streets have ornamental lights: Sixth street from C to I streets, a distance of six blocks; Fifth street, from A to H streets, a distance of seven blocks; Fourth street, from D to E and west side of block from

C to B; D street from Sixth to Third street, a distance of three blocks; and proceedings are now under way for lighting Third street from B to E Street, a distance of three blocks.

#### POLICE DEPARTMENT

Under the present administration the Police Department has been reorganized, and put upon an efficient basis. The ordinances covering the sale of liquor are strictly enforced, and in a number of instances licenses have been revoked for failure to comply with the law. The present strength of the Police Department, in addition to the Chief of Police, the charter officer, consists of the following: One captain, one sergeant, one bailiff, one clerk, five detectives, five mounted policemen,



**FRANK A. SALMONS.**  
Member of Common Council, Supt. Dept. of Streets,  
San Diego, Cal.

three roundsmen, and seventeen patrolmen, one of these seventeen patrolmen being on duty as an acting desk sergeant, and one patrolman is used on special duty at Fifth and D streets, the congested center of traffic in the city. Since the first of January the Police Department has been transferred to a new police station, especially built for the purpose, and leased to the city for five years. This building is equipped with special rooms for the Chief of Police, detectives, clerk and bailiff; there is a garage connected with it, and an emergency hospital. On the second floor of the building there is a Police Court room, with chambers for the Justice and office of the Superintendent of Police and City Prosecutor; also examination and photographic rooms used in preserving records of criminals.



Two modern motorcycles have been added since the first of the year, and two men regularly detailed for this work. The entire department has been armed with new Colts, thirty-eight, special revolvers, officers's model, which is a very recent and up-to-date arm for police service. An excellent Bertillion identification system has been installed, and in a short time the department will have a complete and valuable record system.

The regular sick benefit fund has been established, where rewards have been paid into the department for exceptional services rendered. One-third of the amount of such reward is placed in this fund, and the remaining two-thirds is divided among the officers entitled to receive the same.

San Diego, for a city of its size, is comparatively free from crime, which is due in a considerable extent, to the efficient management of this department.

#### BUILDING AND ELECTRICAL DEPARTMENTS

That San Diego is growing rapidly is evidenced by the large number of new buildings now being erected. Notwithstanding the building permits for the four years prior to January 1st, 1910 exceeded Ten Million Dollars, all previous building records have been broken this year. From January 1st to October 14th, 1910, the building permits have amounted to \$2,787,250, which sum exceeds the total amount for any former year. Since January 1st, 1910, 157 permits have been issued, which makes an average of more than six permits for every working day. The building activity is not confined to any especial section of the city but is general throughout the business and residence sections, and the buildings now being erected would be a credit to a city much larger than San Diego.

The office of Building Inspector was created in March, 1909, and early this year it became necessary to employ an assistant building inspector on account of the vast amount of work in this office. The office of Electrical Inspector was created in 1908 and an assistant inspector has been employed in this office since the first of the year. Rigid inspection of all new buildings as well as old ones is now made in these departments. Both the building and electrical departments are self-sustaining, as the fees are more than sufficient to meet expenses.

#### MUNICIPAL LANDS

In addition to our immense park acreage, San Diego is fortunate in possessing more than five thousand acres of vacant lands lying chiefly in the northern portion of the city. By charter amendment of 1909 all Pueblo Lands owned by the city, lying north of the San Diego River, are reserved from sale until the year 1930 unless ordered sold by a majority vote of the electors. The Council is required to levy an annual tax of two cents on each \$100.00 valuation of property for improving these lands. There is now in this Pueblo Land Fund \$13,454.18 and the office of Pueblo Forester has recently been created and forty acres of municipal lands will be planted to Eucalyptus trees this winter.

I believe these lands can be so improved and beautified that some time it will be possible for the municipality to lease these lands to its citizens and from the rents derived, enjoy an income large enough to support the municipal government without levying of taxes.

San Diego has an opportunity to build on her own lands an ideal city, a City Beautiful, with contour streets, beautiful parks and playgrounds such as artists have dreamed of but never been able to accomplish. While these lands are now worth less than \$200.00 per acre, they must necessarily increase in value rapidly as the city and back country grows and develops. When we consider the fact that

land where the business section of San Diego is now located has increased in value from 26 cents per acre to as high as \$2,000.00 per front foot in a period of forty years, and that lots in the city of Los Angeles have increased from \$5,000.00 to \$500,000.00 within a short time and that the city of Los Angeles has grown from an insignificant Spanish Pueblo to a city of more than a quarter of a million people in twenty-five years and that San Diego's population has considerably more than doubled in the past ten years, it is evident that San Diego's Pueblo Lands must eventually become very valuable. The electors of San Diego believe that in the years to come the lands will prove an invaluable asset and have wisely determined to conserve these lands for the future Greater San Diego.

#### PUBLIC LIBRARY

San Diego has a Carnegie Free Public Library erected at a cost of \$60,000.00.



PERCIVAL WOODS, Councilman

The library is surrounded by beautiful grounds and is well stocked with the world's best literature and is well patronized and appreciated by the public. During the past year 355 cards were issued to new patrons and the approximate number of card holders January 1, 1910 was 16,720. The total number of volumes January 1, 1910 was 35,267, showing an increase of 4,032 volumes during the year.

#### CHURCHES

San Diego is a city of churches and church going people. Practically every denomination of religious belief is represented in the city, the great majority owning substantial church edifices. The city also has a Young Men's Christian Association and a Young Women's Christian Association, both of which are well patronized. A number of new church edifices have been erected during the past year and both the Young Men's and Young Women's Christian Associations are planning for new buildings soon to be erected.

## PUBLIC SCHOOLS

Prior to 1909 the government of the San Diego School District was vested in the Board of Education, composed of eighteen members, two elected from each ward, but the charter amendments of 1909 reduced the membership of the Board to five members elected at large, at the same time and in the same manner as other municipal officers. The members of the Board of Education are elected for four years and serve the city without pay.

San Diego is credited with having a school system far in advance of that maintained by any other city of equal size in the United States. This is not an idle boast but an actual fact substantiated by figures and attested to by every educator who ever visited the public schools of this city.

San Diego is fortunate in havin<sup>s</sup> an unusually strong, loyal, conscientious corps of educational instructors. This splendid force of trained men and women, earnestly working for the welfare of our boys and girls and loyally supported by the people, warrant the belief that, true to their mission, our schools are developing the best type of American men and women.

"At the opening of the public schools of San Diego city, in September, 1906, just four years ago, there were enrolled 230 pupils in the kindergarten, 2070 in the grades and 412 in the high school, a total of 2713 students in all departments. Sherman was then the largest grammar school with an enrollment of 494. The total number of teachers employed was 103, with 17 in the high school, 79 in the grades and six in the kindergarten. Today the enrollment is 5296, with a teaching force of 172 instructors, divided as follows: High school, 35; grammar grades, principals and teachers, 114; supervisors, 8; kindergarten, 15.

Four years ago the work was confined to the traditional courses of study, both in the high school and in the grades, with the single exception that manual training was provided for the boys of the seventh and eighth grades, at a manual training shop located at Eleventh and I streets. Since that time, the curriculum of the high school has been enriched by the addition of new and practical courses in science and mathematics by the complete reorganization of the commercial department along modern, up-to-date methods, and by addition of new departments in mechanical drawing, music and oral expression.

In the revision of the course of study in the grades, the aim of the department has been to meet the present social and economic needs of the individual child. Thorough and systematic drill is insisted upon in the "essentials," reading, spelling, writing and the fundamental operation in arithmetic. But the time formerly given to formal grammar, arithmetical puzzles, and the memorizing of dates in history, descriptions of battles and sailor geography is now devoted to manual training, beginning with raffia work and cardboard construction in the primary grades, followed by a systematic course in woodwork for the boys beginning in the sixth grade, and by domestic science and household arts, including cooking, dress-making and millinery for the girls and instruction in the theory and practical work of agriculture and horticulture for all.

In the establishment of these new departments, and for the more efficient work in music and drawing, special supervisors have been appointed and the work is now under their immediate direction. The adjustment of a corps of teachers to radical changes in the curriculum requires time for its complete development. The establishment of a manual training shop for boys, and kitchens and sewing rooms for girls at each of the large buildings has materially helped in making practical training in the manual arts and domestic science an integral and permanent part of our curriculum.



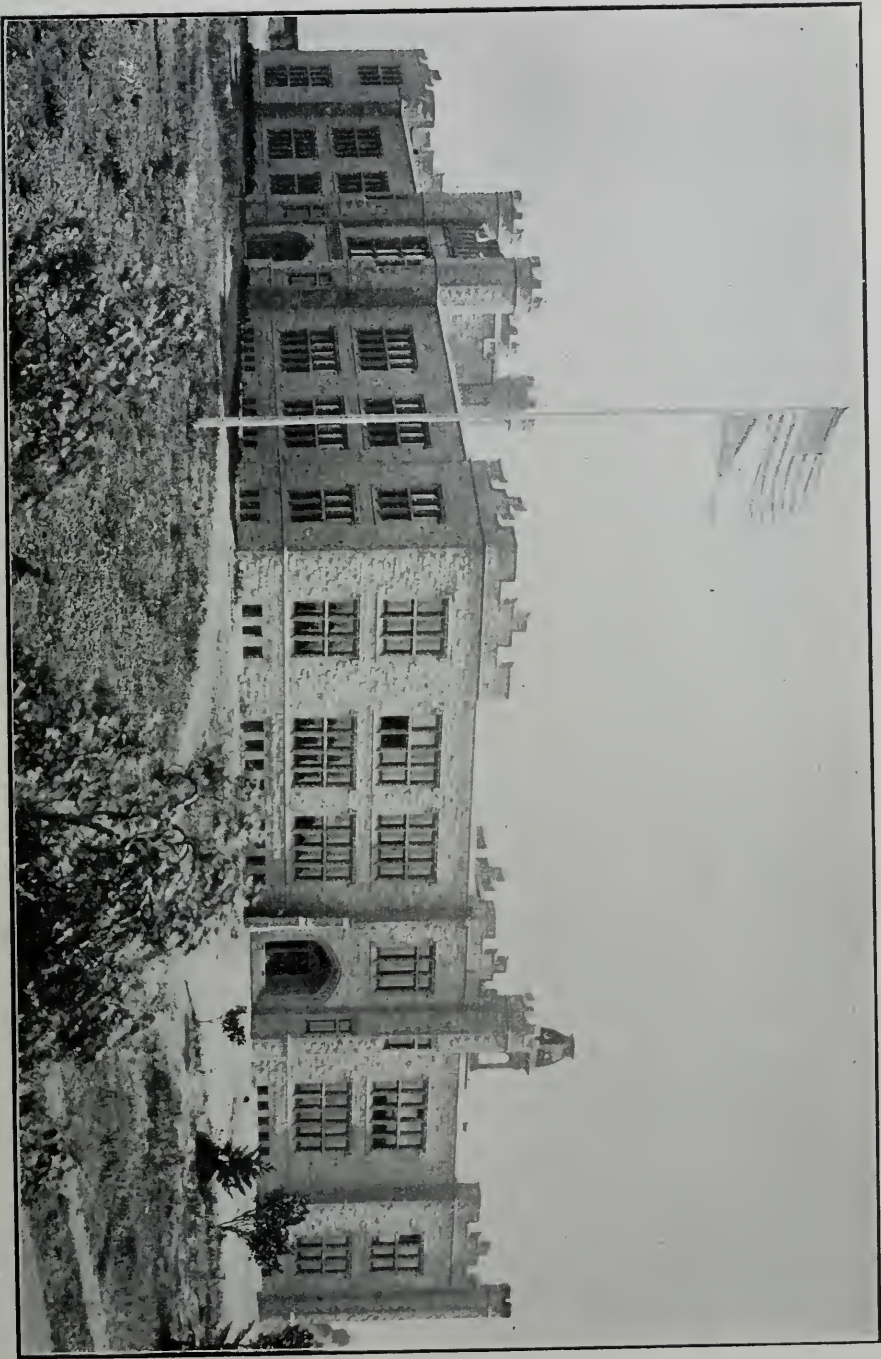

RUSS HIGH SCHOOL, SAN DIEGO

The departmental system of instruction was introduced in the B street school in the seventh and eighth grades three years ago, and has since been established in all the other large schools. It is no longer an experiment. By limiting the number of subjects taught by each teacher, her enthusiasm, efficiency and thoroughness are increased. A vigorous effort is made to reach the individual child through ungraded classes in the schools, where irregular pupils receive special instruction.

The marvelous growth of San Diego in the last few years has called forth extraordinary efforts on the part of the people and the board of education in providing modern up-to-date educational facilities.

In the last four years the average daily attendance in the public schools has increased 10.3 per cent. Within that time our citizens have voluntarily raised \$600,000 over and above the regular maintenance of the school, for new buildings and ground, in order to accommodate the ever-increasing numbers of pupils demanding admission.

During the last few years the entire school department below the high school has been reorganized. Four years ago the Board of Education adopted a broad and comprehensive plan for enlargement and concentration of the grammar schools in the central part for the outlying districts. Seventy additional class rooms have been provided by the erection of five new buildings and two additions ranging in cost from \$5000 to \$100,000, making a total expenditure of nearly \$300,000. In addition to this amount, nearly \$75,000 was invested in school grounds which are today worth twice the original cost.

At the head of the city school system is our magnificent high school building, the most complete and thoroughly equipped building on the Pacific coast. The building and equipment, as it stands today represents an expenditure of about \$220,000. It was thought by many people that the Board of Education had planned for a building much in advance of the development of the city. The enrollment of the school is now 800. The mid-term graduating classes from the grades, next February, will fill the building to its capacity of 1000 students.

What is needed today is to make our system of schools complete, and to provide individual accommodation, in a polytechnic high school in connection with our present institution, where the boys and girls who are now in the grammar grades and the future generation will receive practical instruction in the manual arts fitting them for mechanical and industrial pursuits. We will then have an ideal school where practical instruction and cultural studies are on an equal basis, and where each individual student may gain both intellectual knowledge and mechanical skill.

When the polytechnic department is established, we shall add two more years to our high school course. In other words, we shall bring the first and second years of college instruction to the homes of our pupils, instead of them going abroad to seek it."

Since the above was written the Board of Education has called a special school election for December 9th for the purpose of submitting to the taxpayers of San Diego a proposition to vote bonds to the amount of \$200,000 for the erection of a Polytechnic School.

San Diego also has the finest Normal School in the State.



STATE NORMAL SCHOOL AT SAN DIEGO





DR. KUEHNE

### THE SAN DIEGO BUSINESS AND ACADEMIC COLLEGE

---

The San Diego Business and Academic College on Sixth and D, San Diego, is a "strictly up-to-date institution." This is the opinion of the best people of "Southern California." The methods of instruction are modern, time-saving and comprehensible.

The commercial department is as near perfect as it can be made. Moreover, there is a specially prepared course for ladies and gentlemen who want to go to Europe, or take active part in fine society, desiring to be at ease in their social intercourse of the up-to-date society, can rest assured to be fully instructed to meet all demands. No names mentioned, private study, strictly confidential. This institution has a reputation of teaching the classics, literature, history in a manner second to none. Dr. Kuhne, the principal, is graduated from some of the best European and American universities, and has, therefore, a valuable experience.

The distinguished character of this institution, and upon which it bases its claims to superiority, is its methods of instruction, upon which rapid progress and thoroughness depend. All the leading foreign languages are spoken here. Students can pursue any of the High School and University studies, as well as Architectural and Mechanical Drawing here.

**DEPARTMENT OF FINANCE**

BY PERCIVAL E. WOODS, SUPERINTENDENT OF DEPARTMENT OF WAYS AND MEANS

The Department of Finance of the City of San Diego is a new creation under the amended city charter. The department has organized a purchasing bureau, has inaugurated a system of checking the receipt and disbursement of all supplies and materials used by the city, and checks all accounts, under the control of the Common Council, chargeable against the city.

When we commenced the work of our department we found a very slack method of purchasing materials, supplies, etc. During the past year we have inaugurated a system similar to that used by most large corporations, viz: one head for all the purchasing. Upon receipt of requisition from any department issuing same, and the approval of the head of the department issuing same and the approval of the Finance Department, the purchase is made at the least possible cost to the city. This method has saved many thousands of dollars to date.

In checking the receipt and disbursement of supplies and materials we are protecting the city against waste and loss.

The work of the Finance Committee under the old charter is now handled by this department. In fact, all matters pertaining to finance are submitted to the department for consideration.

**EXTRACT FROM AUDITOR'S REPORT**

The following is taken from the Auditor's report, showing the source from which the city revenues were derived during the year 1909:

From tax levy of 1909.....	\$ 8,966.93
From tax levy of 1909.....	484,078.77
Liquor License.....	55,355.00
Municipal license.....	3,397.91
Dog license.....	1,070.00
Delinquent tax.....	5,199.06
Auditor's fees.....	738.00
Tax deeds.....	12.50
Interest on Bank loans.....	3,822.72
Cemetery, commissioners, sale and care of lots	521.21

**BUREAU OF PUBLIC WORKS**

Engineers' and Street fees.....	9,452.42
Sewer fees.....	3,153.44
Chollas Bridge.....	1,250.00
Blacksmith's Department.....	82.53

**CITY CLERK**

Sale of franchise.....	8,050.00
Rent of lands.....	216.00
Building permits.....	2,657.75
Electrical permits and license.....	4,327.40
Boiler permits.....	5.00
Closing streets.....	108.00
Advertising franchise.....	20.00
Forfeiture deposit on contract.....	350.00
Garbage contract.....	100.00
Sale of charter.....	.25
Rent from Board of Education.....	108.00
Water Department—Collections.....	170,726.29

Carried forward

\$ 763,769.18

PACIFIC MUNICIPALITIES

Brought forward.....	\$ 763,769.18
Sale of old pipe.....	10.00
Park Commissioners:—Street sweepings.....	300.00
Rent Powder House...	195.00
Misc. Collections.....	17.00
City Justice, Fines, fees, etc.....	7,986.75
Health Officer, Permits, Plumbing, etc.....	2,411.35
Fire Department: Sale of discarded material	731.75
Librarian: Fines, etc.....	677.49
Police Department: Rewards.....	50.00
Motor cycle license.....	57.00
Auditor: Filing fees.....	4.50
Refund on claims.....	211.36
La Jolla sewer pipe sold.....	42.30
	<u>12,694.50</u>
Total.....	\$ 776,463.68

The following figures show the expenses of the city, including bond interest and sinking fund, for the year 1909:

Fire Department Fund.....	\$ 52,236.67
Salary Fund.....	118,525.21
Street Fund.....	116,088.15
Police Department Fund.....	5,505.01
Sewer and Drainage Fund.....	20,895.59
Street Light Fund.....	27,539.12
Park Improvement Fund.....	25,019.90
Public Health Fund.....	2,094.39
Library Fund.....	13,811.91
Public Building Fund.....	7,422.79
Office Fund.....	5,875.20
General Fund.....	39,392.87
Legal Fund.....	165.90
Electrical Fund.....	1,433.85
Unapportioned Tax Fund.....	376.28
Dog Tax Fund.....	622.70
Water Fund.....	163,289.86
Cemetery Improvement Fund.....	699.85
	<u>\$ 600,995.25</u>
Bonds redeemed.....	59,200.00
Interest on Bonds.....	89,918.60
	<u>\$ 750,113.85</u>

SUMMARY

Expensed for Material and Supplies.....	\$ 311,014.46
Salaries and Labor.....	289,980.79
	<u>\$ 600,935.25</u>

The total assessed valuation of all property for the year 1908 was \$26,619,596.00 and the tax rate was \$——.

The total assessed valuation of all property for the year 1909 was \$33,814,991.00, and the tax rate was 1.48 per one hundred dollars valuation.

The assessment for the year 1910 is as follows:

Real estate.....	\$ 35,053,526.00
Improvements.....	4,918,252.00
Personal.....	1,977,949.00
	<u>41,949,727.00</u>
Tax.....	545,173.19
	<u>1,349,292.00</u>
Personal Roll.....	17,539.78
Tax on Personal.....	
	<u>\$ 43,299,019.00</u>
Total Roll.....	562,712.97
Total Tax.....	<u>562,712.97</u>

The tax rate for 1910 is \$1.30 per \$100 valuation.



In addition to the above expenditures, the city has expended out of the bond funds for improvements in water extension and enlargement, including reservoirs, sewer extension, boulevard and road improvement, and improvements in the Fire Department, the sum of \$438,309.42.

**REAL AND TAXABLE VALUATION, TAX LEVY AND TAX RATE**

	1910	1909	1908	1907
Real Estate .....	\$36,227,887.00	\$27,878,946.00	\$21,346,718.00	\$18,158,699.00
Personal and Improvements..	7,071,132.00	7,015,590.00	6,453,731.00	5,590,971.00
Total .....	\$43,299,019.00	\$34,894,536.00	\$27,800,449.00	\$23,749,670.00
Tax Rate .....	1.30	1.48	1.48	1.35
Tax Levy .....	562,712.97	517,939.80	411,067.51	320,274.46

**CASH AND WARRANT STATEMENT (INCLUDING TRANSFERS)**

Regular Dep't. Funds	1909	1908	1907
Total Receipts.....	\$ 690,107.75	\$ 590,384.59	\$ 468,251.47
Total Disbursements.....	674,554.31	593,513.03	486,909.36
Balance Jan. 1, 1910.....	\$73,653.60	Balance Jan. 1, 1907.....	\$79,886.49
<b>Bond Imp. Funds</b>			
Total Receipts.....	\$ 62,524.79	\$ 740,725.71	\$ 8.50
Total Disbursements.....	450,078.69	169,061.88	42,416.93
Balance Jan. 1, 1910.....	\$197,697.84	Balance Jan. 1, 1907.....	\$55,996.34
Total of Bonds Issued.....	\$2,160,712.71		
Total of Bonds Redeemed .....	311,250.00		
Total of Bonds Outstanding .....	1,849,462.71 Jan. 1, 1910		
Being 4¼ per cent. of Assessment Roll of 1910.			



**THE SAN DIEGO FIRE DEPARTMENT**

BY A. E. DODSON, PRESIDENT COMMON COUNCIL AND SUPT. DEPT. OF FIRE & SEWERS

At present the department has 63 men, 33 horses, 5 steamers, 1 Rambler auto combination chemical and hose wagon with 35 gallon tank, one double 80 gallon chemical engine, one hook and ladder truck, one Turret hose wagon and six combination chemical and hose wagons. Eight stations are in commission. All of the buildings, and the real estate, with one exception, belong to the city. The expense of the department for 1909 was \$52,235.17. Two Seagrave auto combination chemicals and an 85 foot aerial ladder truck propelled by auto power have been purchased and are expected to be on hand at the coming convention. The fire alarm system is a standard Gamewell containing 57 Gardner alarm boxes on five normally closed circuits. Sixty-four Gamewell latest improved succession non-interfering boxes with box starting keyless doors have just been purchased. The present system contains about 41 miles of wire and the new additions now being contracted for will be 20 additional miles. During the past 18 months no additional horse-drawn apparatus has been purchased, as experience has demonstrated that the auto apparatus, aside from original cost, is cheaper for maintenance, more reliable for long runs and decidedly more efficient an account of its prompt arriva

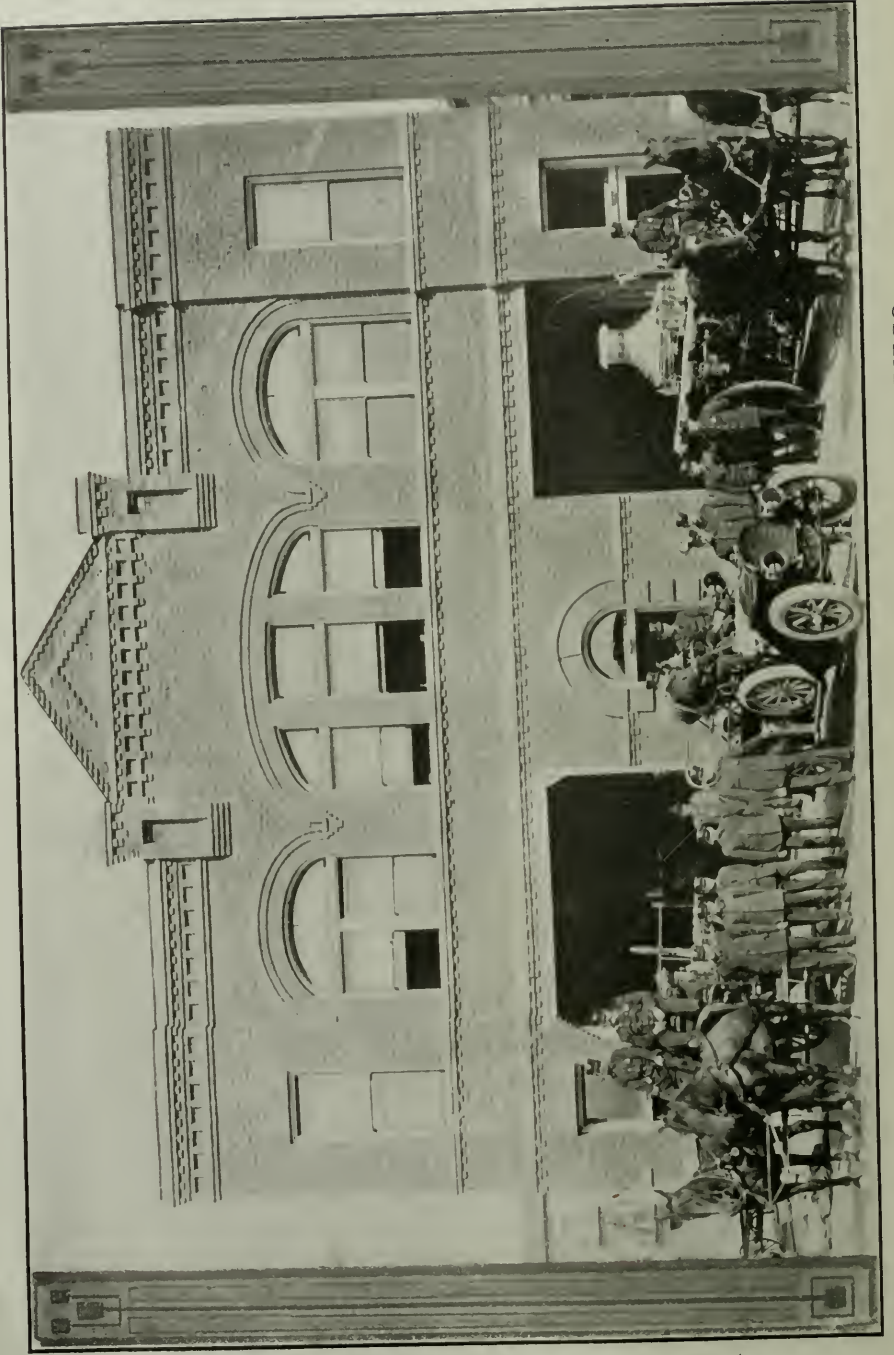

FIRE STATION NO. 1, SECOND AND B STS., SAN DIEGO



FIRE STATION NO. 2, SAN DIEGO



at a fire. It is impossible to give too much credit to the auto chemical in use for about 15 months past. During the first six months it answered 78 alarms, and cost for gasoline and repairs only \$56.67. It extinguished about fifty per cent of the fires before the arrival of the horse drawn apparatus. During the year 1909 the department answered 142 alarms. The total loss for the year was \$41,696.00. Value of the property involved, \$1,368,760.00. During the year, a deputy fire marshal, as well as a traveling blacksmith shop were added to the department and both have proven of great benefit. Good ordinances have been passed and are well enforced, regulating sale, storage and use of oils. Building and electrical ordinances are well enforced.

During the past year the San Diego Fire Department has had two important



**LOUIS ALMGREN, JR.**  
Fire Chief, San Diego

events. One was the successful extinguishment of a blind fire in the hold of the steamer "Alaskan" while in port. This loss was about \$200,000.00 and the value of property involved \$2,800,000.00. The other event was the report made by the National Board of Fire underwriters of a test of the fire steamers of the department which showed an average efficiency of 103.4 per cent. Only one steamer fell below its rating and it showed 99 per cent.

Regular monthly inspections of schools, theaters and other public buildings are made by the captains of the different fire stations. While our department is not under civil service rules, all selections are made for merit only. So far as

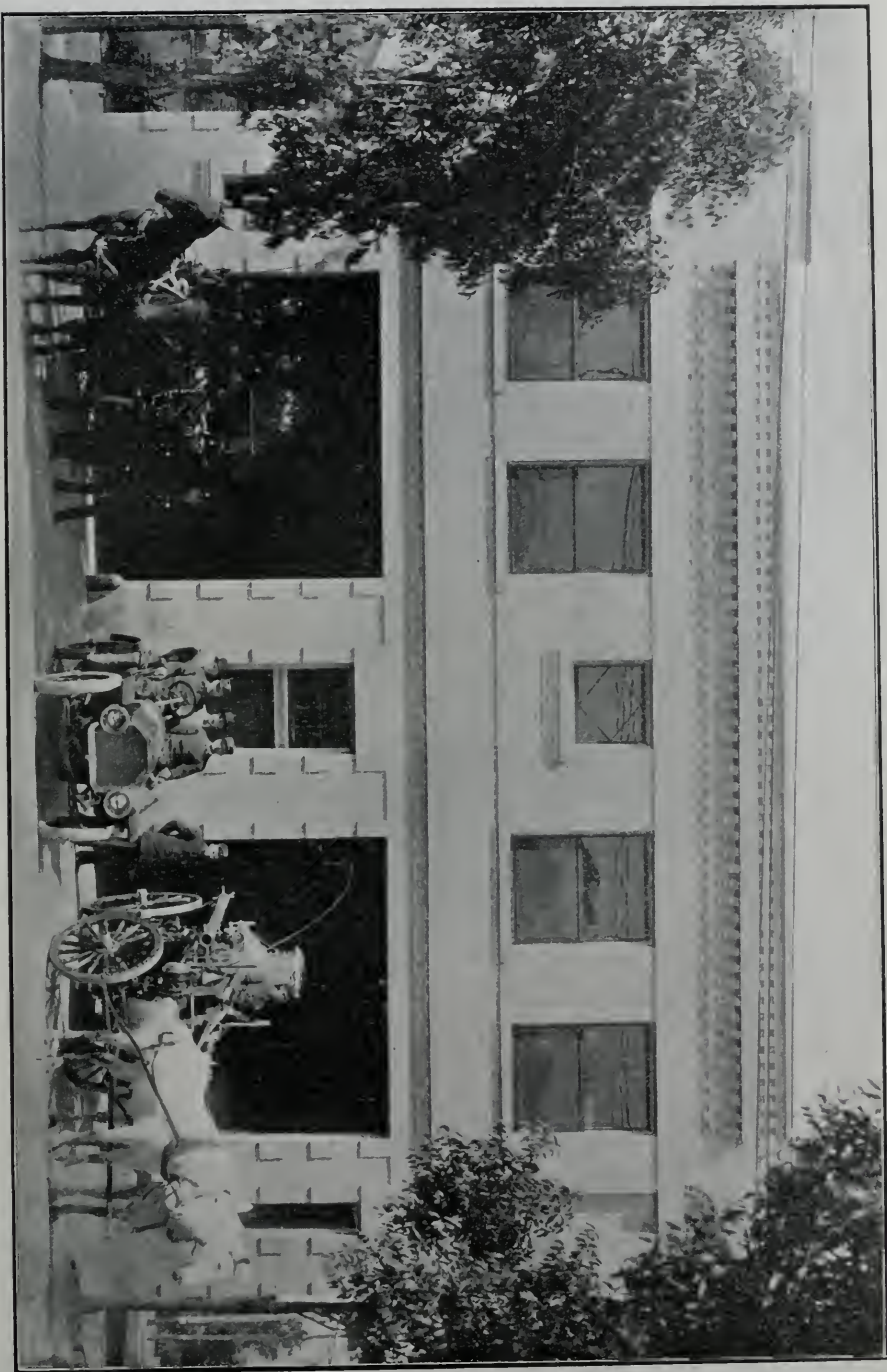

FIRE STATION NO. 3, SAN DIEGO

practicable, preference is given to men having knowledge of electricity and mechanics. We also find good material from those who have served in the U. S. Navy. Selecting men possessing health, character and discipline gives a better fire department than one made up from political favorites.

#### RESERVOIRS

San Diego has eight fresh-water reservoirs ranging from 17,131,622 gallon capacity down. Total storage capacity is 28,740,995, while the source of supply about 22 miles from town has at this time, water sufficient for seven years supply. A recent bond issue appropriated \$340,000 for improving the water system in the city.

#### THE SEWER DEPARTMENT

The San Diego Sewer System contains over 92 miles of pipe, and has cost the city about \$2,000,000. Over 18 miles were laid in 1909. The system drains toward the San Diego Bay, and with the exception of the La Jolla plant all the sewage is carried out with the outgoing tides of the bay. With one exception the entire system flows by gravity. All large extensions have been made from proceeds of bond issues. Smaller lines are put in by general taxation.

On the 9th of August, 1910, the city voted to extend the system so as to include the section lying east of the State Normal School; also all the territory from Washington Heights south and west to the San Diego Bay. These extensions will cost \$193,000, and will be laid under the direction of the sewer department by days work, and not by contract.

Experience has proven that the work done under contract has cost from five to six cents per lineal foot more than when done by the city; but this is not the only advantage of doing the construction by days work. Frequently leaks are found in the lines laid by contract, and upon examination it is evident that the joints were not cemented, or at least, poorly so, and that many "Ys" paid for according to contract were omitted in the construction. Under the days work plan there is no inducement to slight the work, and the difference in the class of construction is in favor of the city. Another advantage in favor of construction work by the city is the right to lower or raise a grade when circumstances require it. If the work is done by contract this privilege is not obtained except at an extra expense on the part of the city.

During the year 1909, 781 permits were issued, and for the first nine months of 1910 there are 440 permits taken out.



## SAN DIEGO'S WATER SYSTEMS

### Showing Various Sources of the City's Water Supply—Engineering Feats Safeguard Populace Against Chance of Water Shortage

**T**HE water problem is the greatest problem which every city must face. San Diego has had her water problem solved by the Southern California Mountain Water company. San Diego today has not only the best water system in the state of California but has the best, purest and cheapest water in the state.



Not until San Francisco completes her Hetchy Hetchy and Los Angeles her \$23,000,000 Owens river project will either of the two great metropolises of the state begin to compare with the water supply San Diego affords her residents.

#### SUPPLY FOR HALF MILLION

San Diego's water supply today is sufficient for a city of half a million population and still the Southern California Mountain Water company is working in the back mountains of the county building reservoirs for water conservation that will impound a supply for a city of more than a million souls.

Early in the year the Dulzura conduit was completed by the company, giving



MAJOR H. R. FAY

Superintendent Department of Water

to the city an available daily supply of 50,000,000 gallons. As the demand of the city is only 5,000,000 gallons per day it can be conceived that back in the mountains is a reserve storage that would serve the city for six or seven years if not a drop of rain fell on the watersheds in that time.

#### BUILDERS ANTICIPATE GROWTH

It is conclusively evident that the men furnishing the capital for the water system and who are furnishing a water supply far in excess of that needed by San Diego at the present time are anticipating the city's future.

The Dulzura conduit completed the last year and which is capable of bringing a supply far in excess of the city's demand is but one link of a chain in a water system which will rival any system in the west and which will cost at the least \$5,000,000. The conduit itself cost in excess of \$375,000.

Despite this expenditure, the work now being done and the contemplated plans, San Diego consumers are getting water at a rate which is remarkably low in comparison with the water rates of other cities. San Diego consumers receive their water supply at rates from 6 to 10 cents.

The water company, under the terms of its contract with the city, supplies the municipality with water at a wholesale rate of 4 cents per 1000 gallons which allows the city to sell it to individual consumers at a cost of from 6 to 10 cents per 1000 gallons, the sliding scale depending on the amount consumed. The city owns its own distributing system within the city limits and distributes the water to the city only.

Prior to the time the Southern California Mountain Water company entered the field to furnish the city with water, the supply was received from the San Diego river in Mission valley. At times the supply was exceedingly low and it became a question of moment how to meet the requirements for the growing city. Several propositions were advanced but all were more or less doubtful, both in the matter of purity and in sufficient quantity. It was then that John D. Spreckels made an offer to the city that has given San Diego one of the finest water systems possessed by any municipality in the country.

#### WATER IS CHEAP

Mr. Spreckels, as head of the Southern California Mountain Water company, agreed to furnish to the city of San Diego, a supply of water upwards of seven millions of gallons a day, if necessary, for a period of ten years. It was agreed by the company that the water was to be delivered to the city at the nominal price of 4 cents per one thousand gallons, a figure considerably less than that which most communities are required to pay for the mere cost of pumping and without the attendant expenses.

From the day the offer was made to the city it was received with favor by the people. Some, it is true, did not lend their immediate assent to the proposition, but they soon came into line and became among the most enthusiastic supporters of the plan. Within a short time the offer was accepted by the common council and a contract was entered into and signed by the mayor of the city.

#### BIG CONTRACTS LET

With the signing of the contract came the preparations by the company for the delivering of water to the city. Contracts were immediately awarded for the constructing of an immense pipe line from the Otay reservoirs, owned by the company, to the University Heights reservoir, at an expense of \$150,000. Other contracts aggregating close to half a million dollars followed in quick succession. Since that time further improvements to the system have been made, at large expense, including the present work on the Morena dam, which will be one of the largest in California.

Despite the fact that the supply furnished the city is of the pure mountain variety, the company has gone even further in its effort to give the people the very best. To this end one of the most expensive and most modern filtering and aerating plants known to science was constructed. This plant representing an outlay of several hundred thousand dollars is the largest of its kind in the state of Califor-

nia. The system of mechanical filtration in use insures the removal of 97 per cent of the bacteria and all microscopic organisms, odor, color and offensive matter held in suspension. It is one of the most modern purification systems known to science, combining sedimentation, filtration and aeration. By its use pure, clear, sparkling and transparent water is always assured. Even were not the water treated in this matter it would in any other city be considered plenty good enough for all purposes.

#### MODEL FILTERING PLANT

The filtration plant is located at Chollas Heights about six miles from the city of San Diego. It comprises a battery of ten filters, the system being known as the "New York Horizontal Pressure System." Each filter is eight feet in diameter and twenty feet long and is made of steel plates half an inch thick. The filtering medium in each filter contains over thirty tons of pure silicia sand brought to this city from New Jersey for the purpose. This sand is different from any usually seen here. It is a bank, not a river sand, each grain being round in shape and, when filtering, the body of the material becomes compact, the result being the same as would be obtained if the water percolated through a solid piece of stone four and a half feet in thickness. The water enters the filter from the top and percolating through the bed of sand, goes through the lateral pipes into the large mains, foreign and deleterious matter remaining on top of the sand.

Clearing the filters from the impurities deposited is simplicity itself. By a system of reversing the valves the pure filtered water from other units goes through the lateral pipes and screens, breaking up the sand bed and forcing all the foreign matter out of the filter and through a trough to the sewer pipes. The whole operation of washing occupies nine minutes and is the work of one man. This cleansing takes place once every twenty-four hours, but once in every forty-eight hours would be sufficient.

All the gates are operated from an elevated platform, so that the keeper has full control of the system and without any laborious work.

The water supply of the Southern California Mountain Water company is secured from what are known as the Cottonwood and Otay watersheds, located miles back in the country and in the heart of the mountains of the Cuyamaca range. The water is stored in an extensive system of reservoirs, all of which are of immense capacity. Of the bigger reservoirs any two of them are amply sufficient to take care of all of the demands of a city many times the present size of San Diego.

In all there are five huge reservoirs owned by the Southern California Mountain Water company. Three of these reservoirs are completed, while work is actively progressing on the fourth. The three reservoirs which are now finished have a capacity of 50,000,000 gallons of water a day, a supply sufficient for a city of 500,000 people. When the fourth reservoir is finished the water will be drawn from an area of 350 square miles of water-sheds controlled by the company, varying from 400 feet above sea level to more than a mile. A sixth reservoir to be located in Pine valley can be constructed at any time it is needed, thus materially increasing the available supply.

Chief among the reservoirs of the system is the Morena dam, which is now under construction and on which rapid progress is being made. The work is being done under the supervision of Chief Engineer M. M. O'Shaughnessy, one of the foremost engineers in the west. Mr. O'Shaughnessy was chief engineer in the construction of four immense conduits in the Hawaiian islands, being engaged eight years in the work, at the completion of which he came to San Diego to take charge.



of the Southern California Mountain Water company's system. He was assistant engineer eleven years ago in the construction of the Spring Valley water system at San Francisco.

The Morena dam is located sixty miles southeast of the city of San Diego at an elevation of 3200 feet above sea level. It is in the heart of the mountains and may be termed the key to the reservoir system. The dam is to be of the rock-fill type with a reinforced concrete face. It will close a canyon eighty feet wide at the bed of the stream. The granite sides rise with a steep slope to a height of more than 500 feet. The dam will have a height of 150 feet and when completed will hold 15,000,000,000 gallons of water.

#### BIG CONDUIT BUILT

When the big Morena dam is filled the water will drop down the Cottonwood river to the Barret dam, ten miles west. This reservoir is to be another important link in the system and, like the Morena dam, will have a capacity of 15,000,000,000 gallons of water. This dam will rise 175 feet above the level of the Cottonwood river. The reservoir will stretch across a rugged gorge, the walls of which rise abruptly to a height of several hundred feet. In order to secure the strength that will be required to hold back the tremendous amount of water, it is necessary to penetrate the walls of the gorge a considerable distance to solid bedrock, in which huge niches are made to firmly secure the dam work.

After leaving the Barret dam the water passes through what is known as the Dulzura conduit, which was completed early last year. This conduit is superior even to the famous Spring Valley water works of San Francisco in construction. It is thirteen miles long and embraces 10,000 feet of tunnel work, the greater portion of which is through solid granite. The conduit pierces the mountain range and brings the water to the western side of the slope, after which it flows into the Upper and Lower Otay reservoirs.

The cost of constructing the Dulzura conduit was great. The big ditch is six feet wide and seven feet deep, and in addition to the tunnel work necessary in its construction, more than one and one-half miles of flume line was built to be used in carrying the water over canyons and deep hollows. Besides the tunnels and flumes there are nine miles of conduit lined with concrete. A concrete curb, six by eight inches in size, with holes for reinforcing rods to permit the conduit being roofed, has also been constructed on either side of the ditch.

The 10,000 feet of tunneling is made up of seventeen distinct tunnels, ranging in length from forty feet to 2060 feet, the latter being in the Cottonwood district of the county. The tunnels, flume and conduit for the entire thirteen miles, have a uniform fall of four feet in every 5000 feet.

#### CHOLLAS RESERVOIR

The Chollas Heights balancing and storage reservoir has a capacity of 60,000,000 U. S. gallons, sufficient to supply the city for twenty days in its present requirements. Its dam is an embankment of earth deposited in layers and rolled. The cut-off consists of a concrete wall built in a trench thirty inches wide at the bottom extending across the valley and a riveted steel plate diaphragm having its lower edges and ends embedded in the concrete. The dam is 526 feet long, 20 feet wide at the top and 56 feet high. It was constructed during the summer of 1901. Water is drawn from the reservoir through a 24-inch cast iron pipe laid in a trench excavated in the natural earth beneath one end of the dam about 38 feet below the top.

The Upper Otay dam, 500 feet above the sea, was completed in 1901. It was created by the construction of a unique arched dam in a V-shaped gorge bedded and resting on solid rock porphyry, base and abutments. It is only four feet thick on top and fourteen feet at the bottom, rivaling for originality and boldness of design the celebrated Bear Valley dam. The Upper Otay dam is located about twenty-two miles southeast of San Diego and has a capacity of 653,000,000 gallons.

To pass surplus water from the Upper into the Lower Otay dam a wasteway has been excavated in the hillside around one end of the dam and seven rectangular overflow notches formed in the top of the dam. Water is drawn from this reservoir through a pipe built into the masonry of the dam, about thirty-two feet below the top. This pipe is controlled by a gate valve on its down-stream end and discharges through a wooden box flume into the river channel near the head of the lower reservoir, which extends nearly to the upper dam.

#### LOWER OTAY UNIQUE

The Lower Otay at 400 feet elevation is also unique and peculiar in construction, being the only dam in existence of the rockhill type, relying in tightness on a diaphragm of one-fourth inch steel plate imbedded in a two-foot layer of concrete with a burlap and asphalt coating to avert damage from rust. It is 150 feet high and 565 feet long and was built in 1895-97. This reservoir is considerably larger than the upper dam, having a capacity of 11,696,000,000 gallons, sufficient to supply the city with its present requirements for eight years on a basis of 100 gallons per head each. The water in the dam would supply the city for several years though not a drop of rain fell.

During the past year the mammoth University Heights reservoir was completed at a cost of about \$105,000. It is of reinforced concrete and has a capacity of more than 20,000,000 gallons and is the largest reservoir of the kind west of the Mississippi river.

In the mountain sheds of San Diego county the annual rainfall is greater than in any other portion of the state south of the Tehachapi and even in the years of greatest drouth a total of more than 25 inches rain is recorded. A considerable portion of the shed which the San Diego water system taps is covered with snow a few months in the year.

The amount of clear mountain water to be caught annually by the Cottonwood and Pine Creek watershed portion which the water company is developing is enormous. Its vastness may be somewhat realized when the average daily discharge has been known to exceed 30,000,000 gallons for a year.

In addition to supplying the city with water the Southern California Mountain Water company also supplies ranchers with water for irrigation.

#### SWEETWATER DAM

Nearly all the large dams of the west are in such remote places that the visitor seldom has an opportunity to view them, but this is not true of the Sweetwater Dam as this much admired structure of masonry is only ten miles from San Diego, and easily reached by a local railroad. It was built in 1888 at a cost of \$250,000 with the one intention of irrigating an immense acreage owned by a Boston corporation. Its original height of 90 feet gave it a capacity of seven billion gallons, but the dam is now being raised and by January first the new structure will be completed thereby increasing its holding capacity to eleven billion gallons which will permit the planting of a much larger acreage.

## THE FLUME COMPANY

The original irrigation system in this section was the Flume Company which consisted of a dam and thirty-five miles of flume carrying 1,000 inches of water. Within the last 90 days this utility has been purchased by a multi-millionaire from the northwest, and it is his intention to improve the entire system with special reference to the construction of one or two large dams each with an immense capacity. A serious mistake was made in this pioneer proposition in placing the dam with reference to a district having a greater rainfall rather than one with having a larger drainage area. In the present consideration it is stated that the new dams will be nearer the sea coast and this will give this system the finest water shed in Southern California.

## WARNERS' RANCH DAM

The owners of the Electric Railway System in Los Angeles have lately acquired large holdings of land within 35 miles of this city, and they are perfecting plans for the construction of the greatest conserving system in the entire state. It is their intention to build a dam on Warners' ranch, with a holding capacity of one hundred billion gallons, which will compare favorably with the great government system of the west.

## ESCONDIDO

Escondido has reason to be proud of its water system. It cost \$350,000 and is the property of the mutual owners, without a dollar of indebtedness. The San Luis Rey river is the source of supply, the intake being in the mountains, twenty-five miles northeast of the city. From the river, during the winter season and up to May 1, the water is brought by a system of tunnels, flume and ditch, to a huge reservoir, seven miles east of the city, with an impounding capacity of \$1,500,000,000 gallons—sufficient for all needs of the valley for three or four years.



## SAN DIEGO PARKS

BY THOMAS O'HALLERAN, SECRETARY PARK COMMISSIONERS

**T**HE park system of San Diego had its beginning in 1872. On June 30th., fourteen hundred acres were set aside by the city trustees for park purposes.

The Parks struggled along for a number of years receiving no attention until a committee was appointed by the Chamber of Commerce to begin improvements on the park.

This committee had authority from the Chamber of Commerce to collect funds for park improvements, which they did very successfully for a number of years.

Later some of the ambitious ones, headed by Mr. Marston decided that the best plan would be to employ the best landscape architect in the country, realising that a comprehensive and artistic scheme for the future as well as the present was most important in the development of the park system.

For this work they engaged Mr. Samuel Parsons of New York City who developed the plans which has formed the basis from the beginning of the work of improvement.

The commanding position of the park affording magnificent views of the



mountains, the bay, the broad ocean, Point Loma on the west, and Mexico to the southeast were all considered in the masterly plans designed for the Park by Mr. Parsons, and in the developments, nothing was allowed to mar the work of Nature, the greatest of all the architects of landscape.

Mr. Parsons has since visited the city at various times and the Park has received the benefit of his expert advice.

During the years from 1903 to 1905 there was a system of boulevards laid out in the Park, which have since proved to be most attractive, adding largely to the beauty of the Park and convenience of its visitors.

On two of these the experiment was tried (in common with so many other California cities) of covering them with oil, which proved to be a poor method of road-making, which many other towns in this state have discovered to their loss.

All of the earlier work was done by a committee of citizens appointed by the Chamber of Commerce, until in 1905 the city organized a Park Commission appointed by the Mayor. They were given absolute control of the Parks which has proven to be the most successful method of managing park affairs.



ELECTRIC FOUNTAIN

Other cities (among them being Denver) have tried District Park Commissions which have proven to be very cumbersome and unsatisfactory.

Since the Park Commission has taken charge of the Parks the work has been carried on with great regularity, and the work of planting trees, laying out paths drive-ways etc. has been carried out on a large scale.

In common with many other California cities, the Park Commission finds the lack of soil one of the most expensive features in park making; but it has been proven by the results that a tree well planted is worth all it costs.

The abundant water supply of this city has provided sufficient water for the trees and their growth has been very rapid.

There are now planted about two hundred acres of trees (largely eucalyptus), flowering shrubs, vines etc.

The two most successful trees in San Diego are the Sugar-gum and *Acacia Baileyana*.

A very interesting chapter in the park development in San Diego is the gift to

the Park from one of its generous citizens, of a large cage of beautiful and rare birds numbering several hundred.

This gift has been installed in an accessible situation in the Park and has been the constant delight of the Park's visitors.

This has been followed by other gifts of bear, deer, cockatoo, parrots &c., which has added greatly to the attractiveness of the Park.

The gift of Mr. Louis J. Wilde of the finest electric fountain in the country is the one thing that the Park Commissioners are the proudest of all the gifts which they have received for the city.

In one section of the Park there are fine golf links which have been very highly spoken of on account of the large number of hazards.

In other sections of the Park are various amusement centers, among them a fine cricket field.

The latest acquisition is a "play-ground". Fifteen acres have been set aside for play-ground purposes, on which is to be built a shelter house—a basket-ball and tennis court—teeter-boards, and all the desirable features to be found in a well equipped play-ground.

The Park Commission is now preparing to expend one million dollars on Park improvements, which with the comprehensive plans mapped out in the beginning of the improvements to the park grounds by Mr. Parsons which will be followed out by the Commission, will result in a harmonious and beautiful addition to the city, unequalled by few if any, of its size.



SAN DIEGO COUNTY COURT HOUSE

## THE NOLEN PLANS FOR THE IMPROVEMENT OF SAN DIEGO

BY JULIUS WANGENHEIM

If one is asked what training and education to give to a boy, the natural answer will be, "Show me the boy." Too often plans are made for such education and training without taking into account the character of the individual. As with the person, so with the city: too often the line of development follows either the traditional line of other cities, or drifts aimlessly with the sporadic development of the town.

San Diego has peculiar qualifications. It is situated in Southern California, "the playground of the United States." In this playground San Diego is unique in being the only water front city. As such it demands a different line of development than should be given to cities in the interior, or to seacoast cities elsewhere. It is bound to have a commercial development, making it one of the seaports of the west: it is also bound to have a steadier growth than a city of homes, a city selected alike for the beauty of its natural situation and its climate.

That San Diego has grown tremendously in the last few years, statistics amply prove. Its population has much more than doubled; its bank clearings, its building permits, its post office receipts, and all things that serve as guides for growth, amply demonstrate this. But more than these, its character has undergone a decided change; it has evolved in the last few years from a town to a city, and as such it has new obligations; the obligations to no longer grow by individual effort alone, but by the concerted movement of its people as well. Recognizing the necessity and the desirability of making San Diego one of the beautiful cities of the country, a possibility for which she is easily qualified, the Civic Improvement Committee, appointed jointly by the Art Association and the Chamber of Commerce of San Diego, decided to engage the best civic architect possible, and once for all define a plan along which San Diego in its growth should continue, and to which all its growth should continue, and to which all its civic activities should conform.

The Committee engaged Mr. John Nolen of Cambridge, Mass., who had made a most enviable reputation in laying out the towns of Savannah, Roanoke and many other eastern cities. Mr. Nolen made a comprehensive investigation, resulting in a definite plan for San Diego, which was later published in book form, highly illustrated. This plan immediately met with public approval, and by general accord has been accepted as the plan along which San Diego is to grow. Its line of development is therefore fixed, and the mind's eye can readily see the City Beautiful slowly unfolding, as therein foreshadowed.

The Committee was particularly desirous that these plans should be in nowise visionary and Utopian, and Mr. Nolen entered wholly into this spirit, with the result that the scheme presented by him is sound, practical and easily attainable.

Foremost among his suggestions was the embellishing of the water front from E Street to Hawthorne. This provided for filling in about 300 feet, bulkheading with seawall and parapet, and providing for broad driveways, walks and parkings. The need of this has long been recognized as, San Diego, qualified to be a beautiful waterfront city, has grown almost entirely as a interior town, without respect to its waterfront. The steps have always been taken to insure the carrying out of this part of the plan, as a feature of the exposition movement. \$250,000 has been set aside out of the funds raised by private subscription, and as soon as the neces-



sary preliminary steps have been taken, the actual work will be commenced. By the time the Panama Exposition is held here in 1915, San Diego will have one of the finest waterfront esplanades of the entire United States, and be in the class of European cities possessing the same advantages.

Another of the features of the Nolen plans is the securing of several blocks in the heart of the town, in the case around the Courthouse, for the purpose of making a Civic Centre, that is, the grouping of such public buildings as the Courthouse, City Hall, Federal Buildings, Art Museum and such other buildings of a public or semi-public nature. This matter is agitating the minds of a number of leaders of public thought in San Diego, and we hope some day their ideas will be actualized.

Another feature of the construction of what is called "The Paseo," being a drive and parkway from the waterfront, as above outlined, to our city park, making practically a beautiful belt drive through San Diego, and connecting its two foremost features, its waterfront and its park. This combination will be the backbone of the system, and will give character to the city, and with it a reputation which is bound to bring its own tangible rewards.

At the intersection of the Paseo and the waterfront there is to be a broad extension for different forms of aquatic pleasures, such as yachting, swimming, etc., for which San Diego Bay is so well adapted.

Mr. Nolen also plans for other small green places, parks and squares, not so much needed now as later, when the town becomes larger and population more congested.

Adequate provision has of course been made for playgrounds, and the attainment and proper care of these is receiving admirable attention at the hands of the local Playgrounds Committee.

The proper planting of trees is duly considered, but present attention to it rather through individual effort than through concerted action.

The laying out of streets is given careful attention for future development, and is on the basis of broad central thoroughfares with narrower lanes radiating from them. It is not so much intended as a change of present location as suggestion for future extensions.

Lastly, the Nolen plans include a comprehensive park system, with connecting boulevards; the system to include the City Park, which is to receive such bounteous aid from the Exposition; the Bay-front Park, as outlined; also one at Point Loma, than which those who know, realize nothing could be finer; a beach reservation somewhere; the park at La Jolla, to be beautified and enlarged; also one at Mission Cliff, overlooking Mission Valley, with its superb vista of hillsides with their changing, flitting colors; the site of Fort Stockton of historic memory to be recovered and improved; and lastly, a Torrey Pine Park to permanently preserve in their wild native state those quaint and curious trees, the wonder of botanists and nature lovers. All of these parks are comprised in the limits of the City of San Diego, all are easily accessible to vehicle and foot alike, all belong to the city, or could be reasonably acquired, and together would make splendid systems of drives and vistas.

It will be seen that all these plans are feasible, and with public support and public acceptance can be, and in the course of a few years will be changed from suggestion into being. A vitalized desire in a community is bound to become an accomplished fact, and San Diego, thriving, active, energetic, will become through these activities, beautiful, attractive, and a city of character and charm, the water-front gem of the Southern Playground.

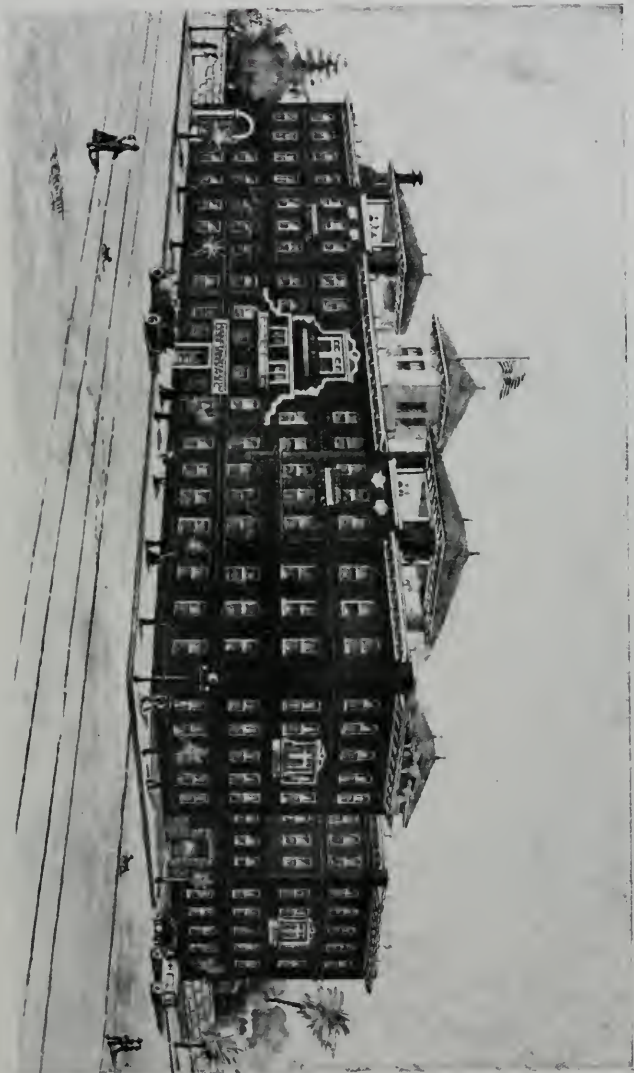

AGNEW SANITARIUM, SAN DIEGO

## SAN DIEGO

## Its Advantages from a Climatic and Hygienic Standpoint

FRANCIS H. MEAD, M. D.

THE climate of San Diego City has been well epitomized by such a well known authority as Prof. H. A. Hare, in his text book of Practical Therapeutics 12 Ed. 1907 as "a place where there is virtually perpetual summer."

There are extremely few climates in the world that compare with this City and its immediate littoral and this important factor has been very immediate in building up the population. A city where the trying heats of an Eastern summer never prevail, and the rigors of winter are unknown is a very comfortable one to live in, and the coming of one family has meant the exodus of others from uncongenial climates. The record of the United States Weather Bureau for the past twenty four years establishes the fact that there has been an average of only six days in each year when the temperature rises above 80 degrees or goes at night below 40 degrees Fahrenheit.

The natural advantages which the City presents are therefore self-evident, and they are especially appreciated by the two extremes of life. Children, with the abundant out-door life are reared more easily and the old find that their span of life is increased with extended comfort.

Passing to the artificial conditions which man has established, we find the first consideration the water supply abundant and of the best quality. During the short rainy season of the winter months the water from the granite mountains flows into and is collected in mountain reservoirs where it is stored for future use. Then each day every drop of water used is filtered to make assurance doubly sure. The relative softness of the water compared with that supplied to many other cities on the coast is a matter especially commented on by new comers.

The best indication of the efficiency of our sewer system is the very small number of cases of typhoid fever which are present. The actual city census has not yet been definitely announced, but will reach somewhere between 40,000 and 45,000. It is much larger in the winter when the influx of winter visitors comes in. Taking the past year only twelve cases of typhoid were recorded and one-third of these were imported cases. Our death rates also, bear out the healthfulness of this section of the state. Careful distinction has to be made between residents (over 12 months) and non-residents, as so many of the latter come here in the last stages of disease in the hope of amelioration.

For the past year 13.33 was the annual total rate. 9.46 per thousand for residents only. It will be recalled that the average rate from the last mortality statistics of the U. S. Census Bureau is 15.00<sup>1</sup> for the registration states and 14.1<sup>2</sup> from the rural sections only. Lastly, excepting Tuberculosis, deaths from communicable diseases are few and far between, such visitations as we have being light.

For those then, who are seeking the most equable and comfortable climates which the world has to offer San Diego offers every inducement, with in addition every advantage of modern civilisation.

1 N. Y. Medical Journal, Sept. '10.

2 Report of Census Office.



## THE LAND OF COOL SUMMERS AND WARM WINTERS

BY LOCAL FORECASTER FORD A. CARPENTER, UNITED STATES WEATHER BUREAU

**F**OR years southern California has had the reputation of having a unique winter climate, and, in the coast districts, the summers are slowly being recognized for their freedom from spells of hot weather. The easterner acknowledges that the winters are warm but that the summers are cool does not



CLIMATIC KIOSK IN SAN DIEGO PLAZA

The weather is automatically recorded in this instrument shelter. This was the first kiosk installed outside of Washington, D. C. It was accepted by the Park Commissioners and by the city by Ordinance No. 3671, April 19, 1909.

appear to him possible, "For," he argues "if the winters are warm then the summers must be warmer!"

The meteorological records show that the climate seems to reach its perfection along the extreme southern coast of California. When Alexander Agassiz visited San Diego in 1872 he said "I have seen many parts of the world and have made some study of the subject of climate. You have a great capital in your climate. It will be worth millions to you. This is one of the favored spots of the earth,

and people will come to you from all quarters to live in your genial and healthful climate—a climate that has no equal.” The San Diego meteorological records were begun in 1849 by officers of the United States Government and have been continued by them up to the present time thus covering a period of more than sixty years. These data present a most interesting field of study. There is space in this brief discussion for only short summaries and general deductions.

*Controlling Factors.*—The causes of this healthful climate are as follows: The latitude; the proximity of the sea; and, the distance from both the storm tracks of the northern and those of the southern coasts. The southern latitude gives a mild temperature; the ocean furnishes cool summer breezes and the warm winter winds; and freedom from storms is insured by the location of this region in the sub-tropical transitional zone.

*Temperatures.*—The lowest temperature ever recorded at San Diego was 32° and the highest 101°. Self-registering thermometers have been used here for over a generation and their records show that the temperature has exceeded 90° on an average of less than one hour per year.

*Sunshine.*—The greatest amount of sunlight occurs in November and the least in May. Cloudy summers and bright winters are the rule. There has been an automatic registration of sunshine for over twenty years at San Diego and the records show that the sun shone on an average of 356 days every year.

*Wind.*—The natural ventilation of the city of San Diego is quite remarkable, for the daily land-and-sea-breeze brings a wind from every point of the compass in a normal day. The winds from the sea are cool in summer and warm in winter for the reason that the temperature of the sea-water off San Diego changes probably less than a dozen degrees in the year. The offshore winds are dry for they blow from a treeless region.

*Rain.*—Meteorologists agree that ten inches or less of rain constitute a desert climate. San Diego is within one-one hundredth of an inch of that classification, for the normal here is 10.01 inches. The rain falls principally in January, February and December, with showers in March, April, October and November. From May to September rain seldom occurs. While the rain in San Diego is light, that of the mountain region back from the town is heavy. Last year the precipitation at San Diego amounted to 14.14 inches, while at Palomar, less than forty miles northeastward, the precipitation amounted to 68.31 inches. The recording raingage at San Diego shows that there were 42 days with 0.01 inch or more during the year 1909, or a total of 232 hours when rain was falling, which makes a “rainy day” average a little over 5 hours. The longest period of rain occurred in January, when it continued for one day and nine hours.

Climatically considered the coast region of southern California has very few objectionable features as a resort for healthy people. California has long enjoyed the reputation of having some of the finest climates of the world and San Diego could well be called the climatic capital of California.

Maximum and Minimum Temperature for the Past Twenty-four Years at San Diego, Cal.

(Compiled by U. S. Weather Bureau)

YEAR	JAN.		FEB.		MAR.		APR.		MAY		JUNE		JULY		AUG.		SEPT.		OCT.		NOV.		DEC.	
	Max.	Min.	Max.	Min.	Max.	Min.	Max.	Min.	Max.	Min.	Max.	Min.	Max.	Min.	Max.	Min.	Max.	Min.	Max.	Min.	Max.	Min.	Max.	Min.
1887	74	38	76	38	82	44	80	44	79	48	78	54	79	60	77	54	79	58	85	50	82	44	74	36
1888	64	33	67	42	72	41	93	47	70	52	76	54	77	55	82	57	82	58	80	53	75	46	73	44
1889	78	36	85	37	80	45	83	47	80	50	72	56	84	59	89	62	91	54	80	52	83	46	69	40
1890	66	35	77	38	74	41	85	45	75	46	93	51	80	56	89	58	83	60	90	49	91	46	79	47
1891	76	35	70	34	76	41	77	44	67	53	78	53	88	58	85	60	89	55	84	50	82	44	72	32
1892	75	38	68	42	73	44	80	41	87	47	75	51	75	57	80	57	80	54	83	46	84	40	71	36
1893	80	38	75	40	75	40	78	43	88	49	75	53	79	57	81	59	77	53	88	50	83	40	82	38
1894	69	32	69	34	72	36	83	43	72	45	73	50	77	57	90	55	90	52	87	45	78	45	70	41
1895	77	36	82	39	74	38	81	44	80	51	77	51	74	57	78	54	90	54	84	54	85	38	79	34
1896	77	39	83	39	85	41	74	42	98	48	89	54	80	56	88	59	80	54	79	52	76	43	76	46
1897	73	40	76	38	70	40	88	46	67	50	70	54	79	59	89	60	83	58	76	51	83	45	80	36
1898	78	36	75	42	77	38	86	45	79	51	88	54	77	60	83	63	91	56	81	51	76	43	79	43
1899	74	43	76	34	86	44	93	46	66	48	70	55	78	57	76	58	92	55	93	48	81	50	80	46
1900	79	46	76	45	80	46	67	45	75	49	87	56	84	60	80	59	87	53	72	50	89	51	79	44
1901	75	40	83	44	82	47	66	46	67	51	86	53	74	57	79	58	72	56	96	51	80	49	76	35
1902	81	36	71	39	76	43	69	47	78	50	76	52	76	55	79	60	73	56	71	52	74	42	74	40
1903	78	43	75	35	72	42	73	47	68	50	74	54	78	59	85	60	83	56	84	51	84	45	75	44
1904	83	36	68	41	74	44	78	44	69	48	74	56	76	59	82	63	86	56	94	53	93	48	78	44
1905	73	46	79	40	76	38	68	44	77	48	70	54	74	59	88	58	81	55	85	50	80	44	74	38
1906	72	35	76	47	80	41	88	42	70	50	89	53	82	58	78	57	91	58	89	46	86	36	80	41
1907	73	35	84	41	82	40	75	43	73	51	80	52	81	59	75	60	79	50	78	54	86	45	79	43
1908	80	44	68	37	78	42	83	46	68	47	70	50	80	56	79	60	84	52	80	48	76	42	68	37
1909	70	42	74	41	74	42	82	46	87	50	77	53	79	58	93	59	100	53	94	49	85	42	71	36
1910	76	34	72	37	84	45	96	47	75	46	71	54	82	56	82	58	86	56						

## GOOD ROADS FOR SAN DIEGO AND ITS VICINITY

BY A. G. SPALDING

**G**OOD roads are among the important assets of any community. To the tourist and mere pleasure seeker, they are not only a luxury, but they serve also to create interest in localities hitherto unvisited, and thus develop a desire on the part of some to gain holdings that would have remained unseen but for the invitation brought by improved highways. To the merchant, good roads are essential, because they stimulate commerce in many ways. To the farmer, they are indispensable; without them, he is lacking a market for his produce, unable to avail himself of the advantages of the public schools for his children and must deprive his family of the benefactions of society and religious gatherings.

San Diego County is to be congratulated upon the progressive spirit of her people along the line of acquiring an adequate system of improved highways. It is no small honor for a country situated as is ours to have taken advanced action in such an enterprise, and yet it is of record that this is the third county in America to vote so large a sum as \$1,250,000 for county highways. And be it known that the task here was of far more herculean proportions than in most counties of the country. Certainly no county of such tremendous size as ours, with topography so bristling, with the necessity of so many deep cuts to fill, so many steep grades to level, so many blind curves to fence, so many cañons to circumvent or bridge, so many granite rocks to blast, ever undertook to construct under a single



bond issue nearly five hundred miles of road, and yet, and that is just what San Diego County has done, and the work is even now well under way.

There is no need at this time to recount at great length the history of the inception and progress of this enterprise. The story is familiar to every citizen of the country. All know that three men, actuated by purely selfish motives at the first, began building roads on their own initiative in the vicinities where they had their homes, respectively. Mr. Scripps worked on the road between Miramar and the city, Mr. Spreckels spent his energies on the highway leading from Coronado towards Tio Juana, and the writer sought to make a road over which he could occasionally reach the city without danger to life and limb.

The citizens of San Diego saw what Scripps and Spreckels and Spalding were doing at their own cost and felt inclined to make an investment on the city's account. They voted \$70,000 in the same direction and secured many miles of magnificent thoroughfares.

Then the taxpayers of the county got interested, with the result that they voted \$1,250,000 for back country roads. Then the Office of Public Roads, Department of Agriculture, at Washington, heard of San Diego's good roads, and Hon. L. W. Page, director of that department, came all the way across the country to see what had been accomplished here. He came, he saw,—and was concurred. He went back delighted at the results.

Next, the need of a road extending along the crest of the United States Military and Naval Reservation on Point Loma, was felt and action urged. It was not easy to secure the cooperation of the government for this enterprise. There is a good deal of circumlocution necessary to overcome the prejudices of the Departments at Washington. Down there they know that an oiled Macadam road is a good one—about the best known up to the present time—and so, after an appropriation had finally been granted, specifications calling for a Macadam road were drawn. Now, one of the requisites for that kind of a road is crushed rock, an ingredient unknown to Point Loma, and only to be found in the mountains, miles and miles away. What was to be done?

First of all, the scruples of the Department were to be overcome. It was necessary to point out that the frost-resisting properties of an oiled Macadam road, such as were essential in New England, were not called for at San Diego. It was essential to convince the War Department that we had a road-making material right at hand that would serve every practical purpose for the Government road on Point Loma. Happily, Mr. Page was "Johnny-on-the Spot." He testified to the quality of the Boulevard he had seen. Admiral Robley D. Evans, "fighting Bob," had also been out this way and passed upon the home-made roads, as "the best in the world." The result was that \$40,000 were made available for the military road on Point Loma, and it is nearing completion.

"The call of the wild," outlying districts of San Diego County for good roads has been long and emphatic. Thousands of acres of virgin soil, on hill slope and in valleys, was remarkable, because almost inaccessible. Lands producing deciduous fruits of wonderful quality were practically valueless on account of damage to the product from long haulage over almost impassible mountain trails. Health-restoring, life-giving springs on ragged rocks, while sorry people suffered from the need of their healing powers were valueless, because only the sturdy mountaineer might climb to their sources in the distant hills.

But that was not all. Scenery equal in beauty to that of the heroic hills of Switzerland, lay hidden far back from the coast. Here, in the geographic words of Dr. Van Dyke.

“The mountains that close the vale  
 With walls of granite, thick and high,  
 Invite the fearless foot to scale  
 Their pathway to the sky.”

But the foot, however “fearless,” after a tramp of fifty or sixty miles, would be too weary to accept the invitation of mountain climbing, and hence comparatively few of our people have ever seen the glories of our Alpine scenery, with its vistas of ocean, valley, canyon, mountain, stream and field. And few, indeed, are they who have stood upon the heights of our coast range and looked down upon that wonderous Imperial Valley, which improved highways of commerce, by team and rail, will soon cause to “blossom as the rose.”

There is not much to interest the visitor in our road-making enterprise, as yet. But residents of country districts all over the county are watching the progress of events, as huge caravans of workmen here and there are tackling the bristling topography, cutting down hillsides, filling canyons, building bridges, leveling inequalities and surfacing the roadways with the best available materials.

San Diego is to be congratulated and is entitled to the grateful plaudits of the whole country as a pioneer in the great work that is but yet in its infancy, but which is bound to go on and on until a huge system is established, extending throughout its length and breadth.

## SAN DIEGO

BY RUFUS CHOATE, SECRETARY OF THE CHAMBER OF COMMERCE

THE first city, the nearest port, the vantage point along the path of commerce, is a concrete description of San Diego, its harbor and its future commercial relations with regard to the Panama Canal. When that great piece of constructive work is completed this harbor city is then accorded her greatest opportunity. Her geological position is the cause of her substantial development and the achievement of splendid results. Her natural resources are being improved and refined and civic pride is causing an awakening in this ambitious city. She has made a phenomenal growth during the last five years and in percentages relative to business and building advancements she is today excelled by few cities. Forging ahead at a wonderful pace by leaps and bounds, she is strengthening and broadening her institution preparatory to entering the competitive commerce fields afforded by this coast. Her building permits will exceed annually an amount of three million dollars and not contented with her fourth position in the clearing house cities of her parent state, she is aiding an exposition and other important propositions in order that she may attain better results.

San Diego rightfully boasts that she has the most equable climate in the world and that in itself is sufficient to attract the homeseeeker, and added to this attractive feature she is most fortunate in having an abundant supply of pure mountain water which has been developed during the last few years, and is today adequate for the largest of our coast cities. Quantity and quality are essential conditions in any water supply but your attention is specially called to the low cost at which it is delivered to the municipal distributing system, namely four cities per thousand gallons.

A harbor—a safe harbor, commodious, one of the ten best havens possessed by our national government is today with its miles of channel water receiving its due consideration and engineers are planning a system of docks which calls for the initial expenditure of several millions of dollars, and extensive areas of tide lands will be reclaimed for general commercial purposes allowing the handling of freight at a minimum cost. The yachts of the eastern shore which are now harbored during the winter in the warmer latitudes of the Mediterranean and the West Indies will seek new waters, coming by the Canal and anchoring off the civic improved portion of our harbor for which one quarter of a million has been appropriated.

It is to John D. Spreckels that the people of San Diego owe their present excellent financial conditions. This city coming into her own by the building of an eastern railroad kept her off the script map during the last panic, placed her on the railroad map and this condition of affairs was due to the person mentioned who had then announced that he was prepared to finance that most important project. The confidence which he then inspired in capital has increased to that extent until today we know its results are causing the construction of mammoth hotels, business blocks, the coming of new steamer lines, and a general industrial development. Fortunate in choice, the opportunity was accepted by him, for the port of San Diego will soon have the distinction of having the shortest and cheapest haul across the state of California, a road constructed on the highest possible standard and one million acres of irrigated land will have its distance lessened to the seaboard by one hundred miles.

Pending the building of the canal this port is favored by a six day freight service from New York by the American Hawaiian Line of steamers whose splendid transportation system is indicative of the results which will come when the canal is completed, which will then make this port the distributing depot of the southwest. The new steamer line to Portland, Oregon, is the result of increased commerce and this company is planning a service which will keep pace with the future growth of the community. The older line with its through steamers to Seattle has improved its service until today one finds the best comforts afforded by any sea-going vessels. The trade of the west coast of Mexico awaits development and a Mexican Steamship Company has granted this port a twenty day service. The announcement is expected at an early date to the effect that a magnificent trans Pacific service will be inaugurated by our direct eastern terminal railroad company which will operate in connection with a well known western company having terminals in the middle west.

At the beginning of our present growth in 1900, capital was timid and it had a tendency toward quick speculative reimbursements, but this condition has bettered itself until today its investment is for future returns. Millions are being expended in the development and the improving of water systems. Tracts of land are being prepared for the actual producers of results which determine the permanent city.

The federal Government recognizes the strategic point of San Diego Harbor, and following the policy adopted on the eastern shore, it is determined that this port the nearest to the canal, must have an adequate naval base. Government engineers are now planning the expenditures of vast sums which will be spent by the war and navy department in placing the necessary war utilities on its magnificent and well protected government reserve of 400 acres.

One great wish now emanates from the minds of the people in this city, and



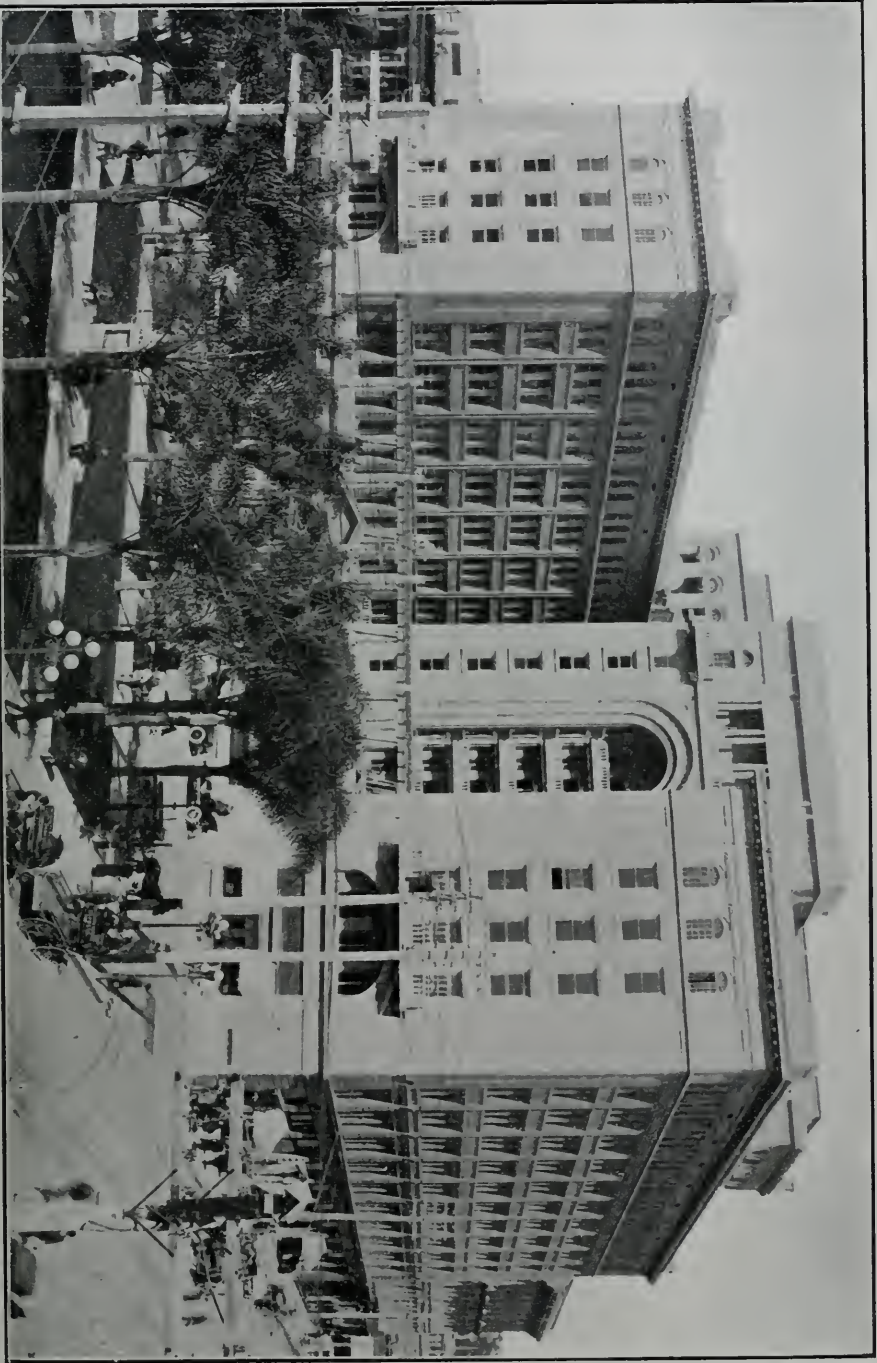

U. S. GRANT HOTEL, SAN DIEGO

that is, that San Francisco will be the world's fair city in 1915. With her financial strength and commercial standing she will be able to attract the visitor from the various parts of the globe. During the same year San Diego will hold a most unique fair costing some \$3,000,000, which will be distinct in its features and in no way will they be competitive as to displays. San Francisco, then a city of 700,000, and San Diego a city of 150,000, and with their splendid harbor facilities, they will then commemorate the opening of the canal in the most fitting celebrations due to the greatest piece of construction work known to man.



## HOTELS

---

**S**AN DIEGO is today equipped with hotels which can take care of a large number of guests and affording all the modern conveniences of larger cities. Although we have been unfortunate in the past in having inadequate hotel accommodations, in this great activity and development of the past few years, the people of San Diego saw the necessity of modern up-to-date hotels, apartments, and restaurants and today our city ranks among the best in the west.

The U. S. Grant Hotel is probably as handsome and as well fitted for the entertainment of guests as any place in the world. It is an immense and beautiful structure of nine stories and roof garden, having 500 rooms (350 with bath) and costing \$1,500,000. Equipped with every modern device for the safety, comfort and convenience of its guests, and occupying one of the best view locations in the city, this great caravansary is an attraction to the tourist and a pride of the citizens.

Across the bay from San Diego, located on a peninsula which divides San Diego Bay from the Pacific Ocean, is the famous Hotel Del Coronado, a hotel unequalled as a pleasure resort, and costing \$1,250,000. Although this great hostelry has been conducted for a number of years, it has from time to time been thoroughly refitted and modernized so that it now presents a cosy, homelike, restful atmosphere, seldom found in such large resorts. It covers four and one-half acres of ground enhanced by well-kept trees, flowers and green plants. You immediately forget the busy world in anticipation of days of quietude, recreation and comforts. This resort hotel, conducted on the American plan, with accommodations for 1,000 guests, has long enjoyed the reputation of being one of the best in the United States. Many visitors are attracted to this beautiful spot by the wonderful climate and delightful surroundings.

In our field of prosperity, the smaller hotels have not been overlooked, and there has been erected in the past year numerous buildings affording all the comforts and conveniences of the larger hostelries. Many of these are run on the European plan, with up-to-date restaurants close at hand. The rates are moderate, the service first-class, and special attention is paid to the tourist as well as to the commercial traveler.

For those who desire the comforts of a family hotel, there can be found many homelike places, fitted up with all the comforts of a home, and with prices which are reasonable. On account of our location, rising from sea level to an elevation of 500 feet, many of these hotels, located in the residence section, afford a magnificent view, with an abundance of sunshine.

Many of the tourists who visit this delightful city, desire apartments for the winter or summer months, and to those we can offer apartments neatly furnished with all the conveniences of a home. These, as well as flats, can be secured close in or out aways near the car line. Any one desiring to visit San Diego need not fear that they would be unable to secure proper accommodations, for San Diego is a city prepared to take care of her visitors. Many new buildings are in course of erection, and we are preparing for an influx of tourists and homeseekers which will come when our new railroad is completed.



HOTEL DEL CORONADO

## LIGHT AND HEAT

**T**HE San Diego Consolidated Gas and Electric Company was purchased April 1st, 1905 by H. M. Bylesby & Co., a Chicago engineering firm which owns, operates and manages public utility interests in several cities.

For many years Dr. R. M. Powers of this city owned a controlling interest in the Company and served actively as its president and general manager. Mr. Powers and other directors of the Company, realizing that the rapid growth of the city called for larger extensions and costly improvements in both gas and electric properties, saw that the Company would have to be reorganized. Therefore, Dr. Powers and his associates decided to relinquish the interests of the Company provided a purchaser could be found who would grant satisfactory terms and give assurance that the property would be conducted in a progressive and efficient manner.

Upon the completion of arrangements for the purchase, a new company bear-



ing the present corporate style was formed with an authorized capitalization sufficiently large to enable needed prospective physical improvements to the property. Before describing the improvements extensions and expansion of the gas and electric property during the last five years, and pointing out how these things have affected the municipal welfare, it is proper at this time to indicate the advantages derived from the present ownership and management.

H. M. Bylesby & Co., believes, and have always maintained that investments in such enterprises should be of a permanent and secure nature, and that utilities should be expected to earn no more than a fair, reasonable annual profit, and in order to insure the security of capital invested in utilities it is held an efficient and adequate service must be given at the lowest possible rates. To a large extent, the success of this theory of the utility operation depends upon the people of the community served and public recognition of the Company's sincerity of purpose and determination to give full value for every dollar received.

The plan of management adopted for the San Diego Consolidated Gas &



SAN DIEGO GAS WORKS

Electric Company leaves questions of policy and general administration to a Board of Directors composed of home men in close touch with local affairs. At the same time, it places the engineering and technical features of the business in the hands of experts who rank among the highest in their respective professions.

Most of the successful utilities are in the largest cities because these companies can afford to employ high priced experts and engineers. The same combination of forces give the centralized management ability to purchase machinery, supplies and materials at a lower cost.

The development of the electric service in San Diego during the past five years has been phenomenal. A great amount has been spent for boilers, engines, systems, pole lines, transformers, service lines, incidental equipment and buildings. The company furnishes heat and light to the entire city and suburbs of San Diego and are extending their services rapidly to several outlying towns. Within the last two years they have extended their electric service to Chula Vista, LaMesa Springs, Ocean Beach and Pacific Beach and are now extending the same to La

Jolla. To these towns power is transmitted at 11,000 volts and step down to 2,300 volts for distribution and 110 volts for service. They have extended their gas service to Coronado, National City, La Jolla, Old Town, City Heights, Logan Heights and Pacific Beach and have a total of one hundred seventy- one miles of gas mains. Also, a total of one hundred twenty-five miles of power lines for electric service.

The company is making vast improvements in both the gas and electric generating and distributing system. At the electric plant at the present time there is installed 3325 horse power in generators for lighting and power purposes. There is now being installed a Turbo generator set of 3375 horse power which will double the present generating capacity of the plant. At present the boiler capacity of the plant amounts to 3500 boiler horsepower to which is being added 1000 horse power more, which will make a total of 4500 boiler horse power.

The gas plant at present has a generating capacity of three million cubic feet each twenty-four hours to which is being added a generating capacity of two million cubic feet, making a total of five million cubic feet each twenty-four hours. The present holder has a capacity of 650,000 cubic feet and in the near future an additional one of two million cubic feet capacity will be constructed.

The company has arranged to offer an especially low electric rate for power and heating purposes. For this reason the citizens of San Diego are among the foremost in the use of all electrical appliances. Several electrical cooking and heating installations are in operation about the city. With the special low rate those people beyond the reach of the gas mains are able to use an electric cooker for household purposes; they operate at a very low rate, approximately \$1.00 per person per month.

The gas and electric distributing system have been constructed to reach the increasing demand in future years in the most economical way. Today its capacity far exceeds the existing needs. With the facilities now at their command the company's electric service is of the finest type and they will be equipped to do a much larger electric and gas business than they now enjoy.



## SAN DIEGO HAS MANY FINE CHURCHES

---

**N**O CITY in the world can boast more churches in comparison to population than does San Diego. Furthermore the religious life of San Diego is remarkably catholic. Sectarianism has been outgrown and it is realized by church leaders that every religious organization has its function in expressing the personality of its adherents. San Diego boasts that it has more churches than saloons. It also boasts that no city of its size has a more complete representation of the various shades of the Christian belief.

In addition to the strongly entrenched denominations known everywhere in the civilized world and which are reaching out into the unchristionized lands, San Diego possesses a surprising number of positive sects and conventicles of cults. A hunt for heresy would bring a small "bag" in San Diego. The city is also proud of the architecture of its church edifices.

## PACIFIC MUNICIPALITIES

## CHURCHES OWN EDIFICES

Practically every church owns its own place of worship and nearly every denomination is represented. At the head of the list is the Roman Catholic Church, both in date of organization and numerical strength. To this church is given the credit of founding and naming San Diego. Aside from the church in old Town, their first church in this city was established at Third and Beech streets, in 1866, where it still stands. At the time of its erection, the newspapers of that date stated that the edifice was located "on the mesa west of town." Today the church is but a few short blocks from the business center of the city. The Roman Catholics have two fine brick structures.

The first protestant Episcopal church in this city was erected in 1886, although services of this organization were held here as early as 1860. St. Paul's church is



FIRST M. E. CHURCH, SAN DIEGO

the parent to two other San Diego Episcopal churches, yet it remains as strong numerically and otherwise, as in the earlier days.

## METHODISTS ERECT HOUSE

In 1869 came the Methodists, who erected what is now known as the Methodist church business block in 1887. Services were held in the old church for a number of years; and pastors who occupied pulpits therein saw the business houses gradually creep up until the church was surrounded by stores and business blocks. In 1905 the cornerstone of the present beautiful structure at the corner of Ninth and C streets was laid and the old church, where once was heard only subjects religious, is now given over to business interests. There are two other Methodist churches in the city.

The Presbyterians first established themselves in this city in 1869, and in



1888 their present imposing edifice was erected. The Presbyterians are strong in numbers and have branch churches in the outlying districts. At about the same date came the Baptists, and in 1888 they also erected their First Baptist church. It is credited with being the strongest Protestant church in the city.

#### CONGREGATIONALISTS BUILD

The Congregationalists, who were organized into a separate body in 1886, held services in a tabernacle until 1896, when they erected their present handsome structure at the corner of Sixth and A streets.

The Central Christian church was organized in 1887, and until recently held services in a large church building at Ninth and F streets. So rapidly did the congregation grow that no less than five times it was found necessary to build additions to the church. Finally the congregation grew to such an extent that a building much larger was necessary. Accordingly plans were completed for a handsome new church building, now under construction, which is to be one of the finest in Southern California and which is to cost \$70,000. The University Heights Christian church is an outgrowth of the mother church.

#### BUILDING PROGRESSES

Another fine church building on which work is nearly completed is that for the First Church of Christian Science. This church is to be erected at a cost of \$50,000 and when completed will be a notable addition to San Diego's houses of worship. In many respects it will be one of the prettiest churches to be found in this section of the state.

In addition to these, some of the most prominent denominations and houses of worship, there are the English Lutherans, the Methodist Church, South, whose members are planning a new church, the Unitarians, who are also to shortly begin the construction of a new church building, and many others, smaller, but none the less aggressive along religious lines.

In addition to its churches, San Diego has a number of missions, including those for the spiritual enlightenment of Mexicans, Japanese and Chinese. There is a mission for sailors and homes for the unfortunate, aged and orphans, all of which are doing splendid work.

The larger churches maintain men's clubs and other laymen's organizations. The churches also have a full quota of women's societies, aid societies, missionary societies and other auxiliaries and in no city is this branch of religious work more active in philanthropic work.

Young peoples societies are maintained by most of the churches in accord with their denominational plan and they are busy and useful. The Sunday schools embody all that is modern and aggressive in that line of church work. San Diego, too, is proud of the calibre of her pastors.

## SAN DIEGO HARBOR

**S**AN Diego Harbor is in the form of a crescent about 15 miles long, varying from three-quarters of a mile to two miles in width with an area of 22 square miles. Probably the best way to describe this land-locked port which ranks among the ten best national harbors is to describe its conditions from the entrance to the end of the channel waters. On the bar at the present time there is a channel 150 feet wide with  $28\frac{1}{2}$  feet of water at low tide. On either side of this deeper portion there is a width of about 800 feet having a depth of 25 feet at low tide. The distance across this bar is 1900 feet and at the last session of congress \$125,000 was appropriated which will allow the deepening of this entrance to 30 feet with a width of 600 feet at low tide. It is estimated that with an expenditure of less than \$250,000 the depth can be increased to 35 feet at low tide, the length of this portion being 3700 feet and at each end we find a depth of 60 feet. The government to date has spent on this harbor about \$650,000, and a major portion of this amount was used in the construction of a jetty which begins near the entrance of the harbor and runs parallel to Point Loma. Government Engineers

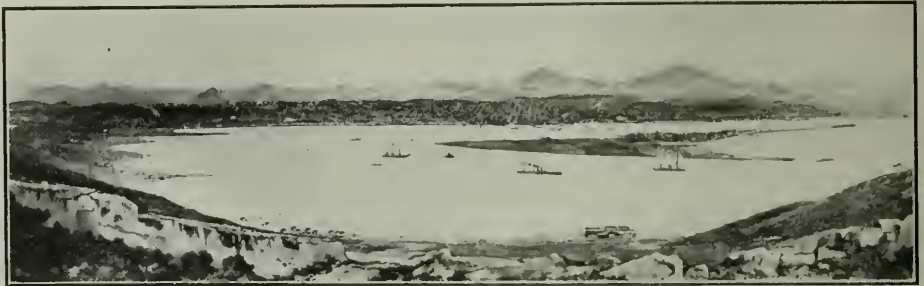

BAY OF SAN DIEGO

have determined that by the construction of a small jetty, which would lessen the width of the entrance near the bar, we could easily maintain a depth of 35 feet at low tide without further dredging other than the first removal of this obstacle. Just inside the entrance of the harbor is a stretch of sand over which the depth is only about 25 feet at low tide, and vessels at the present time drawing a greater amount of water have to take a sharp turn and take a north channel where there is 60 feet of water. This present appropriation will also allow the removal of this middleground and allow a straight entrance for any size ship.

To a distance of eight miles from the entrance of the harbor we find a channel 2600 feet wide with a minimum depth of 35 feet at low tide and a large portion having a depth of 40 feet. From this point to that of twelve miles from the entrance we find a minimum depth of 25 feet and at this point the channel narrows to that of 1,000 feet with a minimum depth of 20 feet. No dredging has ever been done on this harbor except on the bar, and previous to the present appropriation 30,000 was the largest amount that has ever been expended at one time and on account of the small appropriation the charge for yardage has been beyond all reason. The lowest bid under previous contracts was 75 cents per cubic yard while that of the present bid was only 18 cents. The anchorage area in San

Diego Harbor is about eight square miles, and the tidal range is about  $5\frac{1}{2}$  feet. It is well to note that no disaster has ever occurred in San Diego Harbor which was caused by the elements, and it should also be stated that the entire bed of the harbor is composed of sand but firm enough to afford the very best anchorage, and no rock has ever been discovered in the bay, it causes little fear to vessels should they by accident leave the main channel. The wharves and docks are inadequate for the growing needs of commerce, and the city now has under consideration a detailed plan which when once completed will meet every demand of the future. At the present time we have about 2500 feet of dockage with which to accommodate our commerce and as these wharves are owned by private concerns it aids little in the development of new business. In the plan which the city is now developing we will have 22,000 feet of sea wall having a minimum depth of 35 feet at low tide and in this construction work we will reclaim 900 acres of land which can be used for general commercial purposes, and its location will be from one to two miles from the business center. There will also be a belt line railroad connecting this system of docks with the terminal railways. It is estimated that the cost of this proposition will be about \$5,000,000 dollars. The thing which is uppermost in the minds of the people of San Diego is to refine the natural conditions of our harbor and offer every possible facility which will minimize the cost of handling freight.

## SAN DIEGO AND ARIZONA RAILWAY CO.

---

The San Diego and Arizona Railroad is now being rapidly constructed eastward and it is authoritatively stated that the line will be completed within 24 months. The maximum grade on the entire road will be 1.4 per cent, with its highest possible standard of construction and it will give the port of San Diego a great vantage point and the trade of the southwest. The estimated cost of the line is \$12,000,000. The story of its results is better told by interview with the builder of this terminal railroad.

### PRESIDENT SPRECKELS SHOWS HOW THE NEW RAILROAD WILL BENEFIT THE GREAT SOUTHWEST

The building of the San Diego & Arizona railway will open up to San Diego a new line and method of business. Imperial valley, Arizona, New Mexico and Northern Mexico will be opened up to trade relations with the City of San Diego. San Diego will be able to reach this territory quicker and cheaper than it can be reached from any other coast city. It means that manufacturing and wholesale houses will necessarily be established at San Diego, because the territory they will serve can be reached to better advantage from this city than from elsewhere.

At one time, San Francisco had most of the business of the Pacific coast. She has lost, however, a great deal of her territory. She can no longer sell to advantage in Los Angeles, and has lost nearly all her territory in the northwest, but she has made up all her loss by the greater population she serves now in a comparatively restricted area.

Much business now goes by the way of Los Angeles that, on the completion of the new railroad, will be taken care of by San Diego. The taking away of this



business from Los Angeles will not necessarily injure that city, because she, in turn, will benefit by a larger population growing up within easy distances.

The whole Pacific coast and the states immediately bordering upon it are offering advantages that cannot be duplicated in the eastern states. The tendency is for the east to come west. Europe, also, is sending a large quota of her emigrants to the coast, where the opportunities are greater and better than in the more thickly settled states of the east. There is more new country to be developed, and, therefore, more new business to be started; and consequently, there are greater opportunities for people who come out here than can be found in the older and more settled communities.

A vast lumber business is handled at San Pedro and shipped by way of Los Angeles to Imperial, Arizona, New Mexico and other so-called Pacific coast territory. A great deal of this can be handled by the port of San Diego, and undoubtedly will be handled through this port. Business is like water; it finds its own level, and, moreover, travels along the line of least resistance. The man who orders goods as a rule wants quick delivery. This is, generally speaking, a prime factor in business. If he can get his goods quicker from San Diego than from Los Angeles or San Francisco, San Diego will get the business.

San Diego, through her new railroad, is going to be in a position to reach some territory more rapidly and at less expense than it can be reached from any other town; consequently, San Diego will get the business.

I believe considerable influence will be exerted on San Diego by the Panama canal in conjunction with the Arizona railway in the matter of European emigration. Ships can come direct from Europe through the Panama canal and land their emigrants in San Diego, and from this point distribute them over a great deal of territory much easier than by way of New York and other eastern ports.

It is difficult to estimate just where the benefit will begin and end in the opening up of new territory by a new railroad. I am convinced that San Diego has a splendid future before her, and the beginning of this great future will dawn when the San Diego & Arizona railway is in operation as a direct line to the east.

San Diego has a climate which has no superior. Work can be carried on here to greater advantage than in the east, where it is too cold in the winter and too hot in the summer to get best results. San Diego has a good water supply and a fine harbor; all three of these being most essential to the making of a city of importance.

## THE BANKS OF SAN DIEGO

\$1,800,000 represented the total bank deposits in 1900 and it is truly gratifying to announce that in 1910 this amount has been increased to that of over \$11,000,000.

During the so-called panic some three years ago when almost every city of importance in the nation issued scrip, as its legal tender for the transaction of business, San Diego stood out alone as the only Pacific Coast city which continued to do business with gold and silver and national bank notes. Scrip was unknown save as it came from the other cities.

It is a gratifying fact that the capital stock of our banks is nearly all owned in San Diego, and that when the opportunity affords, outside capitalists are eager to purchase stock in any one of our financial institutions. Able and conservative bankers are at the head of these concerns. The confidence of the people in the solidity of the banks was such that during the financial stringency there were no

withdrawals except for necessary business transactions, and it is further evidenced by the constant increasing deposits. Two very significant facts are worthy of consideration. When the county offered \$1,250,000 worth of road bonds, it naturally attracted competitive bids from the larger outside banking institutions. A number of concerns agreed to take the issue but the accepted bid came from a local bank and San Diego is today furnishing the money with which to build her magnificent system of boulevards.

New York, San Francisco and Los Angeles refused Imperial Valley the assistance which she desired in handling her cotton crop, and the local bankers came to the rescue and this year the people of that section can proudly state that they are the producers of nearly \$1,000,000 worth of cotton.



**PACIFIC WOOD AND COAL CO.**

This popular company (of which Mr. D. F. Garrettson is President and Mr. J. S. Akerman, Secretary) was organized in 1889, and is the largest wholesale and retail concern in the city dealing in coal, coke, wood, hay, grain, fertilizers and seeds. They also represent some of the strongest organizations in the fuel and feed business in the country, among others being the American Agriculture Chemical Co., The American Beet Sugar Co., American Fuel Co., Spreckels Brothers Commercial Co., Pratt's Food Co. of Philadelphia, and the Western Food Co. of San Francisco. They have contracts with the government and the city and keep a large stock constantly on hand. Their facilities for handling a large amount of business are unequaled, having spur tracks connecting with the different railroads and the wharf of the Pacific Coast Steamship Co. They have a number of branches scattered throughout the outlying districts.

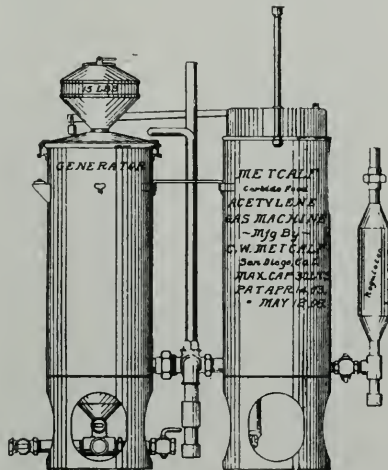

**METCALF ACETYLENE GAS MACHINES**

One of the most successful industries in San Diego is conducted at the factory of Mr. C. W. Metcalf, 352 Fifth Street, San Diego, when the Metcalf Carbide Feed Acetylene Gas Machines are manufactured.

It is a well known fact that acetylene gas is practically unexcelled for illuminating purposes, but its usefulness is not confined to this field alone. It is now being used with perfect success for cooking and heating. It burns with a steady,

clear, white flame, requiring no mantel, yet giving a highly pleasing glow, which eyes weakened by age or overwork are keenest to appreciate. The apparatus manufactured by Mr. Metcalf, according to numerous testimonials, is giving perfect satisfaction to all who have installed it.



### THE GLOBE MILLS

One of the latest industrial establishments of which San Diego is proud, is the new Globe Flour Mills, which were completed about April 1, 1910.

The buildings are of the most modern type in point of construction and arrangement, and are absolutely fireproof. They are equipped with the latest and best machinery for the manufacture of high grade flour, and not only the plant itself, but the methods of operation used throughout are of the most sanitary character in every respect. This establishment is one of the most substantial evidences of San Diego's modern growth and commercial expansion. The mills turn out from three hundred and fifty to four hundred barrels a day.



### THE LUMBER INDUSTRY IN SAN DIEGO

San Diego Building permits have increased from about One Hundred Thousand Dollars in 1900 to more than Three Million Dollars for 1910. During the same period the population increased from seventeen thousand to forty thousand. These two sets of figures are indicative of the phenomenal development of the resources of San Diego and vicinity. Almost three times as much building material has been consumed each and every month during the year 1910 as was used during



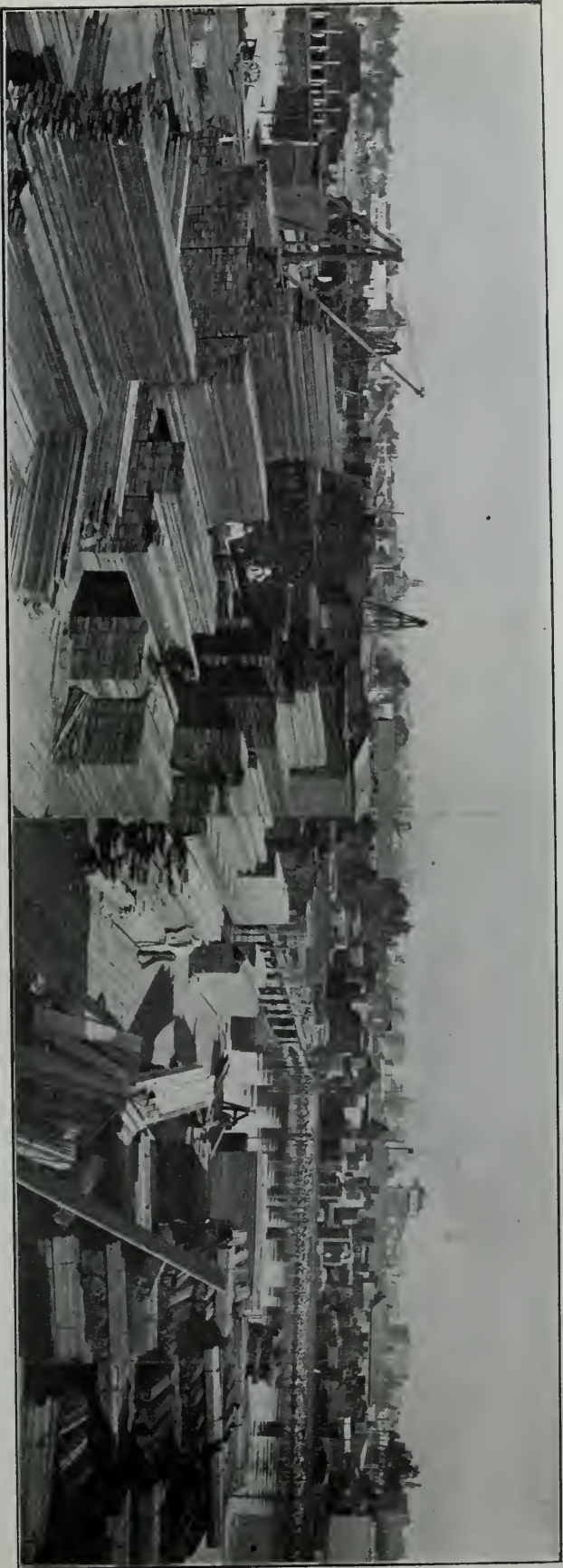

LUMBER YARDS IN SAN DIEGO

the entire year of 1900. The Wholesale Lumber Yards and Mills have kept pace with the growth of the City and are fully equipped to meet all demands of the trade. The yards are stocked with many millions of feet of lumber of all varieties from which the most exacting consumer can find just what his needs or tastes may require. The Mills are equipped with the most modern machinery for promptly turning out all kinds of mill work, sash, doors, boxes, etc.

There are large lumber wharves on the Bay Front, reaching out to deep water where cargoes may be discharged direct from the decks and holds to wharf. An unique feature of the lumber industry of San Diego is the bringing of large rafts of lumber down the Pacific Coast from Oregon and Washington forests. During the last three years, fifteen of these rafts, aggregating more than sixty million feet of lumber have been towed down an ocean trail over twelve hundred miles long, brought up the bay and anchored alongside the mill without a single accident or the loss of a single log. These rafts averaged about nine hundred feet in length, by fifty-five feet wide and thirty-five feet in depth.

The different lumber yards and mills of San Diego and vicinity give constant employment to more than six hundred men and the number is being rapidly increased from month to month.



MAIN STREET IN RUSS LUMBER & MILL COMPANY





View of the Raja Yoga Academy and Aryan Memorial Temple, International Theosophical Headquarters, Point Loma



## LA JOLLA

---

**T**HIS peer of natural seaside resorts is located fourteen miles north of San Diego, on the line of the Los Angeles & San Diego Beach Railway. Personally conducted excursions are run daily to La Jolla, and important points of interest are shown to visitors. The caves are probably the most famous of La Jolla's attractions. People climb in them and on top of them, speculating as to the origin and extent. The first cave to the west is accessible at all times through a tunnel, consequently it is the most frequently visited. At low tide it is also possible to enter this cave thru the mouth. The other caves, however, face deep water and can be visited with safety only at extremely low tides and by people in bathing suits. This latter condition is not obligatory on visitors, but is suggested for their personal comfort. The White Lady, formed by the bright light at the entrance and outlined by the walls of the cave, is found in the fourth cave



A STREET OF COTTAGE CITY, LA JOLLA STRAND

from the Devil's Slide. An interesting story has been written about the phantom White Lady by Mrs. Rose Hartwick Thorpe. Copies of the book may be procured at La Jolla. It is well illustrated, and can be kept as a souvenir of La Jolla. The Devil's Slide is a highway to unique Rocky Beach. Many of the fine abalone shells are found on the rocks here at low tides. Formerly the people slid down the face of this cliff and then climbed up again as best they could. Now, a stairway of about one hundred steps makes the visit to this beach one of greater personal comfort. Long Beach, further to the north, is a long, smooth, white, sandy beach, probably a mile in length. At either end of this beach will be encountered high bluffs and rocky beaches, which prove a source of much interest to students of beach formations. During the summer months the beach line is explored for several miles north and south of La Jolla by those attending the summer Biological School, conducted by professors from the University of California and many Eastern Universities, including Yale and Harvard. La Jolla's surf line is made up of entirely different features at every step; no two places alike. The most important

of these formations include: Gold Fish Point, from which countless gold fish may be seen swimming through the water; Emerald Cove, with its improvised stairway, natural bridge and three entrance cavern; a delightful and absolutely safe bathing cove; Alligator Head, also with its natural bridge and caverns.

The sand is a pure white, and the rocks are carved by the action of the water



**THE HOTEL AT LA JOLLA STRAND**

into curious formations, resembling alligators, hippopotami, mushrooms, and a thousand-and-one other curious shapes and forms. Scripps' Beach, with its nooks, crannies and caves, forms a popular picnic beach. Whistling Beach derives its name from the peculiar whistling sound made by the sand as one walks



**THE ROCKS, LA JOLLA STRAND**

along the beach. From Mt. Soledad, immediately in the rear of La Jolla, is to be obtained one of the most remarkable and beautiful vistas of San Diego scenery. It is not really a mountain, as it is only 821 feet above the sea level, but the elevation is sufficient for the climber to command an unbroken view of land, mountains and ocean. On clear days the mountains north of Los Angeles, Riverside

and Redlands may be seen, some of them probably fifty miles away. In addition, the Santa Catalina, San Clemente and Coronado Islands, are plainly distinguishable out in the ocean.

### BIG PLEASURE PAVILION

Rising from the plateau overlooking the beach, will be an artistic and commodious pleasure pavilion. The plans of Mr. Beachman, the architect, provide for a most attractive looking structure 140 feet wide by 80 feet deep. Across the entire front of the building will run a wide porch, which will no doubt be a favorite promenade for residents and visitors to the seashore colony, and through the center from front to rear is a wide open court in which palms and other ornamental plants will be set out and in which space is reserved for a large fountain.

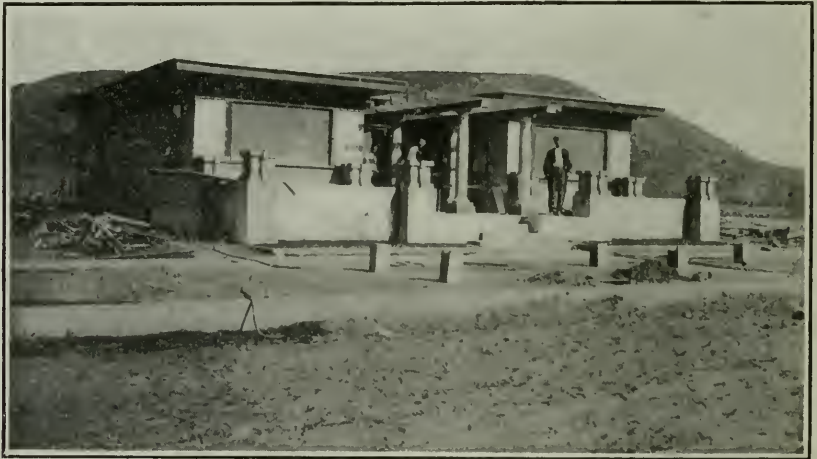

TYPICAL STRAND HOME UNDER CONSTRUCTION

If you are in search of infinite variety, if you want something besides a long stretch of sand to your seashore resort, if you like to clamber over rocks, catch crabs in a thousand crannies and nooks, explore caves as wonderful as any in the world, watch the great Pacific billows break over sandstone islands and ledges, and at the same time find sheltered bathing beaches tucked snugly away from all chilly breezes; then La Jolla is the place you have dreamed about—for that's just what La Jolla is, your dream of a paradise on the seashore, where you can play with comfort every day in the year, come true.

The people of La Jolla are in keeping with the place, for they are largely composed of folk that have traveled over the world, looking for an ideal spots for homes and who, when they got to La Jolla, exclaimed, Eureka!





OCEAN BOULEVARD, CORONADO TENT CITY

## CITY OF CORONADO

BY GEO. HOLMES, PRESIDENT OF BOARD OF TRUSTEES

**C**ORONADO, a city of the sixth class, is beautifully situated on the extremity of the peninsula which forms the seaward littoral of the Bay of San Diego. It is a city of comfortable homes for a population of nearly 2000 people, attracted thither by the most perfect climate in the world.

It is reached by a twenty-minute ferry service from San Diego, or by railroad seventeen miles around the bay.

The town was originally laid out in 1886-87, the streets graded, shade trees planted, a sewer system and water plant installed, and railroad facilities, both steam and electric, provided.

Prior to 1890, Coronado was a part of the city of San Diego. In the spring of that year it was incorporated as a separate city. It is now governed by a board consisting of five trustees. The city officials are City Clerk, City Marshall and Tax Collector, City Attorney, City Treasurer and City Engineer.



BIRDSEYE VIEW TENT CITY, CORONADO

The trustees are elected at biennial elections. Each candidate is nominated by petition, and two or three of the members retire every two years. Each trustee has his own department; Finances, Improvements, Health and Morals, etc., and they receive no remuneration for their services.

Until two years ago, very little work was done in street grading and paving, but lately this branch of public improvement has been given an impetus and several miles of streets are now under construction. Coronado, in conjunction with many other California cities, has been considerably handicapped by the intricate workings of the Vrooman Act.

In a few weeks the people will vote on seven different items of a bond issue, as follows:

1 Sewer system, east of A avenue	\$ 17,500
2 K Street Sewer and bay outlet	10,000
3 Fund of placing sewer laterals in alleys	8,000
4 Re-paving Orange avenue, (the main thoroughfare)	67,000
5 Planting palms along Orange avenue	2,000
6 Improvements to the fire system and purchase of chemical truck	10,000
7 Acquisition of a city hall	15,000



POLO GAME, CORONADO COUNTRY CLUB GROUNDS



Aviator Hamilton Flying Over Coronado Country Club Grounds, Feb., '10



If these bonds pass, which seems probable, Coronado will leave little to be desired as an ideal abiding place.

Coronado has:

No saloons or slums.

Three public parks.

The famous Hotel del Coronado.

Five Churches.

Excellent public and private schools.

A population of 2,000.

Two miles of electric and two miles of steam road.

Five miles of paved streets, every street having shade trees.

A beautiful \$20,000 reinforced-concrete public library, the gift of Mr. John D.

Spreckels.

The Gamewell fire alarm system.

Streets lighted by electricity.

A water supply of unexcelled purity.

A capable health department.

A Country Club famous for its international polo matches, a polo field, unequaled anywhere in the world, an excellent golf course, race track, and aviation field.



Pony Races, Coronado Country Club



Tennis Court, Coronado

Coronado's wonderful all-year-round climate brings many thousands of visitors to the city every year. In the winter these are taken care of by the famous Hotel del Coronado and the many attractive smaller resorts and cottages. The hotel never closes its doors. It is built around a large court which contains many rare and beautiful plants and trees. Accommodations for about 800 guests are provided. In the summer great throngs visit the delightful Coronado Tent City, where all the amusements and comforts of an ideal sea-shore resort of the kind are to be found.

Owing to the almost constant presence in the sheltered waters of the bay, of numerous war vessels of the United States and other nations, there can always be found in the local colony a liberal sprinkling of "the navy." Many brilliant functions of a distinctly naval character are held in Coronado every year. It will be a matter of a short time only when there will be established here a permanent naval station.

There are many handsome residences on the beach, but the comfortable and attractive California bungalows predominate, giving the visitor the rightful impression that Coronado is essentially a city of homes. On account of its geographical isolation one sees no vagrants and no disorderly element of any kind. The place is therefore a paradise for children as well as for the grown ups.

According to the U. S. Weather Bureau Reports, the winter temperature of Coronado is  $8^{\circ}$  higher than that of the most favored winter resort, and its summer temperature is  $10^{\circ}$  lower, making an average of  $9^{\circ}$  in favor of Coronado as an all-the-year-round resort. "Coronado is unquestionably the best seashore resort on the Pacific Coast and it is equally enjoyable in winter and in summer" says Dr. Guy Hinsdale of Philadelphia, Secretary of the American Climatological Association.

But in addition to the advantages of an equable climate, to quote Charles Dudley Warner, "There is a geniality about it for which the thermometer does not wholly account, a charm which gives a feeling of absolute content and willingness to stay on indefinitely."

The future of Coronado is assured.



RESIDENCE OF JOHN D. SPRECKELS, CORONADO



## PANAMA-CALIFORNIA EXPOSITION, SAN DIEGO 1915

**I**N the city of San Diego there will be held throughout the entire year of 1915 an exposition intended to exploit the industries and the productions, both natural and artificial, of the Southwest states of the United States of America, and of Mexico, Central and South America. The exposition is to celebrate the completion of the Panama canal, and will be known as the Panama-California Exposition.

The citizens of San Diego are promoting this exposition, and have subscribed liberally towards the expense of building it. It is a San Diego project, primarily, but the lines upon which it is being carried out are so broad that it may, with propriety, be called an international exposition. No requests for financial aid have

been made, or are to be made, to federal government or state by the people of San Diego, but because of the fact that the exposition is to embrace in its scope a vast territory commercially tributary to the United States, and more particularly to the west coast of the United States, the nation and the state are asked to lend their official sanction, to the end that foreign governments may recognize the exposition more readily.

It may be urged on behalf of San Diego's purpose that San Diego is logically the place for holding such an exposition. It is the first port of call in American territory north of the Panama canal, and the port nearest to the Great Circle of Commerce between Panama and all ports of the Orient. San Diego is the only practical shipping point for the Southwest by ocean routes. Its harbor is the only safe and commodious haven, with the the exceptions of San Francisco and San Pedro, between Puget Sound and Valparaiso. It is the most direct terminal on Pacific waters for all the west-bound commerce as far east as Kansas City. It is on the shortest route between the Orient and the Southern and Middle Western states.

The history of the enterprise may be stated briefly: Early in August, 1909, a small group of business men gathered at the San Diego Chamber of Commerce to discuss the advisability of holding an exposition in San Diego in 1915 to commemorate the opening of the Panama Canal. This was a very serious question to be discussed by representatives of a city which could not, at that time, boast of a population of more than 40,000. The thought that impelled these men to consider such an undertaking was not a selfish one, but rather a desire to acquaint the world with the advantages, resources and possibilities of the undeveloped Southwest.

With this idea firmly fixed in their minds, they settled upon San Diego as the logical gateway of that vast fertile and little known territory between the Rocky Mountains and the Pacific Coast, and extending in the extreme South almost to the Gulf of Mexico. At the same time they realized that the first port of call North of the Pacific entrance to the Panama Canal might rightly claim the privilege of exploiting the resources of this region.

Because of the need for closer relationship between the countries which border the Pacific, these men desired that the Panama-California Exposition should be international in its scope, including, not only North America, but the countries of Central and South America. Upon arriving at this decision, the Panama-California Exposition was incorporated and subscriptions opened. In less than four months the entire capital stock of the Company, amounting to one million dollars, had been fully subscribed.

San Diego has two of the greatest possibilities in California in her Harbor and her Park. After a full discussion of their relative merits, it was definitely decided to hold the Exposition proper in the City Park, and also a supplementary Water Carnival on the bay.

To this end, a bond issue, of one million dollars for Park Improvements, was put before the people and was almost unanimously carried. At the same time a competent engineer was employed to draw plans for the improvement of the water front. These plans are nearing completion and at the next session of the legislature San Diego will go before the representatives of the people at Sacramento and ask that the State cede to the City of San Diego her water front.

Plans for the Exposition proper are rapidly maturing and before the opening of 1911 ground will be broken and buildings will be in course of construction.

The Panama-California Exposition will be unique and educational, inasmuch



as it will deal in specific things; eliminating most of those features which have been deemed an essential part of past expositions.

There are four main features around which the Exposition will revolve; history, irrigation, reclamation and colonization.

As a basis for the historical exhibit it is proposed that representatives of all the native tribes of our own far West, Mexico, Central America and South America be gathered in one vast exhibit. It is the intention to reproduce, as far as possible, their architecture and their modes of living, together with tribal arts and industries, in such a manner as to preserve the story of races fast passing away. The gathering of these tribes, particularly those from South America, promises to be a difficult undertaking, but such a feature has never before been attempted, and should prove of paramount interest.

It is proposed to demonstrate the manner of storing, carrying and applying water for purposes of cultivation, from the period when the aborigines build rude ditches and adobe reservoirs, up to the immense masonry dams and aqueduct of the present day, which are among the most remarkable engineering feats of the age. The Exposition can serve no purpose more useful than to acquaint the people



Copyrighted

of the country with the transformation that can be accomplished by intelligent and scientific use of water in our so called deserts. We desire to show that the conservation of water in these arid districts points the way for thousands of homeseekers who may find comfort and even luxury on the millions of acres still undeveloped.

The Government has spent, and is spending, vast sums of money for the reclamation of arid America. Nearly all of this wealth is being distributed in the southwest, where a territory as large as the State of New York, hitherto believed to be unproductive and of little value, is fast becoming a rich and fertile garden. Few persons outside of districts affected by these projects have anything like an adequate acquaintance with the work and the opportunities it has created, but there is every reason to believe that when these facts are made known through demonstration it will create a world wide interest in the development of this section of the country.

Having a vast undeveloped and sparsely settled territory with plenty of water, a region capable of producing every known variety of fruit and grain, it remains to people that territory. It will be the effort of the Exposition directors to induce the

larger steamship companies operating on the Atlantic Coast to bring to this port such classes of immigrants as are possessed of the energy and ambition necessary to contented residents in the southwest. When this is accomplished two great markets will have been established. The tiller of the soil must buy and sell, the manufacturer who utilizes must do likewise, and the capitalist who develops is also obliged to keep a portion of its earnings in steady circulation. A demonstration of these facts such as is planned at San Diego, the gateway of the southwest, will bring the people and the capital.

It is the endeavor of the Exposition Directors to make, as far as possible, every exhibit one of educational value. For instance, the cotton industry in Imperial; cotton can be raised on the Fair grounds and the visitor can walk through a field of growing cotton at the end of which will be a gin in operation; beyond, he may follow through the various stages of the operation of turning this raw cotton into cloth.

The mining industry of Nevada, California, Arizona, New Mexico and Mexico will be thoroughly exploited. On the flank of the plateau upon which the Exposition will be held, will be sunk a model shaft, showing drifts, inclines, slopes, tunnels, cross cuts and chambers, in which the visitor can see the modern methods of gathering ore. At the top of the shaft, in a miniature mill, this ore will be reduced and the gold extracted. Passing on, this same gold will be converted into articles of commerce. In this exhibit will be a large display of native San Diego gems. These also will be shown in the workings and on through the different processes until they reach the hands of those artisans who will set them in the gold that but a few minutes ago the visitor saw in the ore.

A model irrigation ditch will be constructed, out of which will be carefully measured one inch of water, in an endeavor to show the uninitiated the dormant possibilities that lie in that quantity, when applied scientifically to a fertile soil.

The Panama-California Exposition will be opened for one entire year, from January 1st to December 31st, 1915.

Here the romance of the southwest will be concentrated in a few hundred acres by the reproduction of California's old missions and those historical features which have made the southwest the land of legend for all who love a tale of freedom, daring, hardships and achievement. There is every reason to believe that the Panama-California Exposition will not only attain its main object of exploitation but that it will be a financial and industrial success.

It is the boast of San Diego that in no other place on this continent would it be possible to guarantee, upon the weather records of thirty years, a perennial exposition in the open air, and no day of which the gate receipts would suffer by reason of inclement weather. On no day of the entire year, San Diego feels perfectly safe in saying, will there be any inconvenience or uncomfotableness experienced by visitors to the exposition.

The confident belief of those who are promoting the great project of San Diego is that during the year of the Panama-California Exposition thousands of immigrants will be booked directly from Europe to the Pacific Coast through the Panama canal, and that the bulk of these will make their first landing on American soil at San Diego. Once landed here and the exposition will give these immigrants grand opportunity for close investigation of the resources and possibilities of the whole Pacific coast country.

San Diego's status in relation to all exposition enterprises for 1915 in commemoration of the completion of the Panama Canal, is practically unchanged from the original intention. The so-called "Washington Compromise" with the representa-

tives of the Panama-Pacific Exposition to be held in San Francisco, as formulated by Senator Flint and approved by Director-General D. C. Collier of the Panama-California Exposition, is still in force, having been confirmed by the officials of the Panama-Pacific Exposition in further conference with Director-General Collier representing the officials of the Panama-California Exposition.

The basis of this understanding between San Diego and San Francisco is an explicit agreement that the entire California delegation in Congress shall favor and do all in their power to pass a resolution inviting all the nations of the world to participate in a fair to be held in San Francisco in 1915; and that thereafter the delegation shall favor and do all in their power to pass a resolution inviting the Republic of Mexico and the nations of Central and South America to participate in an exposition to be held in the year 1915 in the City of San Diego.

Subsidiary to this agreement and in conformity with Director-General Collier's suggestion that some substantial benefit should accrue to Southern California from the "Compromise," the representatives of the Panama-Pacific Exposition, including Governor Gillett, Senator Flint, the California delegation in Congress, and officials of the Panama-Pacific Exposition, agreed that the California delegation in



Copyrighted

Congress will support a proposition to secure for San Diego the establishment of a government farm and national experiment station for promotion and development of agriculture and horticulture peculiarly adapted to the requirements of Southern California and the Southwest, to remain permanently in San Diego.

Subsequently, in conferences between the officials of the Panama-Pacific Exposition and representatives of the Panama-California Exposition, and in still more recent conferences between Director-General Collier and members of the legislature it was conceded that there would be no difficulty in securing from the next legislature an appropriation for an agricultural college and school of forestry as part of the San Diego Exposition program. In this effort San Diego will receive the full support of the Panama-Pacific Exposition influence individually and collectively.

Thus, while the purposes of the two expositions are distinct exposition enterprises, it is expected that the San Francisco fair shall be a world's fair in the fullest sense of that term, surpassing in magnitude and scope anything of this character ever attempted. The contest between San Francisco and New Orleans is one calculated to rouse the State pride of the respective citizens. Louisiana is making a strong appeal not only to its own citizens in this regard, but it is demanding that



the entire South shall "stand together" for the honor of the "section." Naturally, therefore, the West and the Pacific Coast was solid for California, confident that if money and energy can win, the Golden State will not be found lacking in either.

The benefit to be derived by California, the Pacific Coast and the Southwest from the expositions in San Francisco and San Diego will be substantial and permanent. The State will derive a profit from these expositions far in excess of that which may be calculated upon the returns from the throngs that will be attracted to the fair. The expositions will serve as an advertisement for every section of the State. This alone is worth more to the various sections than similar publicity procurable in any other way. No doubt that same end will be secured as the years roll on, but it will certainly pay handsomely on the investment to hasten the process.

San Diego has made a personal appeal for the aid and support of Southern California on behalf of the Panama-Pacific Exposition because the ultimate success of the San Francisco enterprise insures for San Diego and Southern California substantial, permanent improvements wholly aside from the temporary profit of an exposition.

San Diego believes that harmony of action will do much to allay the natural jealousies existing between sections so widely separated geographically and so diverse in their material interests. A common cause, enthusiastically supported, would certainly bring the people of the two sections much closer together on other matters than would be possible in any other circumstances.

It may be stated in conclusion that San Diego's interest in the success of the San Francisco exposition enterprise is two-fold. The immediate return upon San Diego's investment of \$2,000,000 will be larger if a world's fair is held in San Francisco; and the permanent benefits to be conferred under the arrangement between the two cities will be absolutely assured.



## MUNICIPAL MILK FOR BABIES

BY MILO HASTINGS IN S. F. EXAMINER

Eighteen years ago Nathan Straus learned that a large percentage of deaths among babies was due to impure milk and could be avoided by giving special care to the production and handling of this all important product.

Now, special care and cleanliness require extra labor, and labor costs money, but Mr. Straus was a rich man, and he established pasteurizing stations and milk laboratories and paid for the extra expense out of his own pocket and sold the milk at ordinary rates or gave it away.

For a rich merchant to sell a poor mother milk for five cents that costs seventeen cents to produce constitutes charity, and charity, we are told, is bad for society. But Mr. Straus, whatever may be his sociological creed, found that he was saving the lives of hundreds and hundreds of babies and was satisfied.

Now it appears that for commercial and personal reasons Mr. Straus' very efficient milk charity is being attacked. Believing that these attacks, directed against himself, will discredit the principle of the babies' right to live, Mr. Straus has announced his intention of giving up this work.

What a pitiable reflection upon the social and co-operative abilities of mankind is the entire milk situation in New York city! Here is a city of five million souls, and most of its inhabitants are at one time dependant upon cows' milk for their lives, and the supply of that highly variable and highly perishable article is produced at places far removed and distributed by ways too intricate for the individual family to grapple with, and yet the matter is not considered as a suitable field for municipal enterprise.

Now comes a man with his private charity and stays the hand of the digger of thousands of little graves, and then by announcing the discontinuance of his self-appointed work fills with fear the hearts of ten thousand mothers who have availed themselves of his aid, and who now will be forced to join the ranks of the hundred thousand others who must draw the life fluid for their babies from the milk tanks of commerce, even though they find in the bottom of each glass settlings like the silt in the bed of the Hackensack river.

The natural suggestion of the present situation is that New York city take over the work that Mr. Straus has been doing and extend it so that every mother may have opportunity to give her baby the best milk that science can produce.

To make such work effective it would be necessary to confine the use of municipal milk to babies and invalids and to put the price as low as the cheapest grades of competing milk. Without such restrictions the efforts of the city would be appropriated by the well to do, just as has been the case where certified milk and other high grade goods have received official approval.

Some time we may be able to devise a practical means by which the whole population can be guaranteed pure food and honest merchandise, but with existing conditions of public sentiment and municipal organization we must content ourselves with undertakings wherein the results are great compared with the expenditure of cash and the inroad of precedent involved. Mr. Straus has shown that pasteurized milk for babies belongings in this class.

There is undoubtedly much truth in the argument that the extension of charity to adults encourages vagrancy and improvidence, but putting hobos to work and condemning babies to a diet of filthy milk are quite different matters. Public provisions for the best growth of the bodies and minds of children is not charity in the offensive sense that the term implies in the case of adults. The lengthening of the period of infancy or the greater care given to the young is the means by which all higher forms of life have been developed, and this applies to the action of society as well as to the care of the individual parent.

Pure milk for babies is sound logic and sane civilization, and its worth has been proven for private charity, just as private institutions first demonstrated the feasibility and worth of our present splendid municipal schools and libraries. Public schools for children were bitterly fought at the time of their inauguration, and municipal milk for babies will be fought now, but it will come, and the sooner it comes the fewer little headstones there will be in the cemeteries.



## SANITATION IN SOUTH AMERICAN CITIES

Extract from an address before the Women's Municipal League of New York

BY MRS. PERCY JACKSON

One finds every stage of sanitary advancement exemplified in South America. In Lima, the old vice-regal capital in colonial days, and now the capital of Peru,

though the water supply is dubious and the drainage not very good, the narrow streets lined with old Spanish houses are well paved and kept clean, and the ashes and garbage collections are better made than in New York. All the street cleaning is done at night, as it is every where in South American cities, and the sidewalks are never allowed to be decorated, as they are with us, with garbage and ash cans. The important Chilian towns, Valparaiso and Santiago, show better and more modern conditions than in Peru, but is on the east coast, in Argentine and Brazil, that one finds the greatest contrasts to what one has considered the typical Latin-American city. Buenos Aires, the capital of the Argentine and one of the greatest of Latin cities, with a population of 1,200,000 has as modern and advanced an appearance as any European city. The streets are well paved and kept and are cleaned by a nightly flushing with hose, a luxury that New York has sighed for in vain, and there was no cleaning done during the day, apparently, though the streets never seemed dirty or littered. The water supply is a safe one, the docks are extraordinarily clean and neat, the parks are attractive and in every way the city seemed well managed. There is much interest in hygiene, as has been shown by the holding of an international exposition of hygiene as part of the centenary celebration now going on in the Argentine. The municipal authorities have also showed their good intentions, even if their wisdom may be disputed, by ordering the pasteurization of all milk sold in the city. Good as many of the conditions are in Buenos Aires, the greatest surprises in South America in the way of sanitary work are to be found in Brazil, as Rio and Santos, both of them within a very few years having been veritable plague spots and terribly dreaded by every one who was forced to visit them during the yellow fever season. Santos, the great coffee port, was so deadly that sometimes three successive crews would die of fever before a ship could be loaded and got away, and all the English boats that made regular stops there sent their crews to the hills on arriving and had the ships loaded by immune natives. Within a few years all this has been changed by the work of Dr. Cruz, under the Brazilian government, and now that the mosquito-breeding swamps have been drained and replaced by docks, one can go there with impunity in the worst season. The work done at Rio is equally striking, and this once unhealthy town now has a low death rate and has no terrors for the traveler at any season. The water supply is excellent, the streets are well paved and are kept very clean, being flushed and cleaned at night, and there are two municipal regulations that might well be copied elsewhere, one being for a fortnightly sanitary inspection of all dwelling houses, including hotels, and the other being an ordinance compelling all butcher shops of every class to be lined with tiles, both the floor and walls. Rio has a very beautiful waterfront, most of it of recent construction, and the municipality a few years ago cut a wide avenue through the old part of the town to the great improvement of sanitary and aesthetic conditions. Dr. Cruz, who was for some years in charge of the work in Rio, has now given that over to an assistant and is at the head of the great government institute for pathological research that is now being built, and to the credit of the Brazilian government it should be said that he is given practically carte blanche in this work and is given, as he told us himself, all the money he wishes.



## ITEMS OF INTEREST

---

**The Fable of the Long Ballot.**—Once upon a time a Plain Citizen went to the polls to vote. The ballot contained the names of a hundred candidates for a score of offices. "That ballot is not for me," said the Plain Citizen. "That ballot is for experts only. I'm as good as disfranchised by it!"

"You ought to go into politics and become an expert yourself," said the Politician.

"I can't. Economic pressure keeps me hard at work to support my family. That's my first duty."

"Lucky for me!" murmured the Politician.

"Why is politics so complex? Why are there so many picayune elective offices?" persisted the citizen.

"So that you will always need me," the Politician replied, as the Citizen, without even reading the names of the candidates, helplessly voted a straight ticket.

**MORAL.**—The longer the ballot, the less the Plain Citizen counts in politics. The "Short Ballot" used in Des Moines, Galveston, and abroad, is the right remedy. A "Short Ballot" carries only a few conspicuous offices and the citizens hold easy and effective direct control over their government.

**Novel Method of Financing Sidewalk Laying.**—Richmond, Ind. The accountants of the State Accounting Board in their report call attention to the peculiar method of financing the building of sidewalks which is used only in Winchester. The citizens get permission of the Council to construct the walk, pay the contractor in full, and then are allowed a refund certificate by which the amount is deducted from their taxes. The legality of the method is referred to the State Law Department but the experts state that the procedure has certainly stimulated the building of fine cement walks in the city.

In considering the adoption of a charter the people of Pomona are taking a step in the right direction. If they will have the patience to take plenty of time and cull the best things from the most modern thought and experience along these lines they can establish a form of government which will be a model for all the rest of Southern California.

**How We Forget.**—Experiments have proved that the average "forgettery" works very fast. Within twenty minutes we forget 40 per cent of our present experience; after thirty minutes, 50 per cent; after two days, 72 per cent; after thirty days, 80 per cent.

No wonder it is necessary to keep at it, and keep at it, in order to make advertising a success; that is, in order to remind the public that you want them to buy your goods.

### SUBMITTING QUESTIONS TO THE SAN DIEGO MEETING

Any municipality may submit any question or questions to the convention for its opinion. Such questions should be submitted in writing by the delegates or mailed to the league headquarters. The source of such inquiry will not be disclosed if so requested.

PACIFIC MUNICIPALITIES  
QUESTIONS AND ANSWERS

---

OCTOBER 11, 1910

Q.—THE LEAGUE OF CALIFORNIA MUNICIPALITIES,  
SAN FRANCISCO, CAL.

DDAR SIR:—

Will you kindly inform us if a license can be exacted from a corporation furnishing water to a town. Previous to this time our water company has not been required to pay any license although light and other companies do. These said water people claim they are not subject to license. Will you kindly inform us at your earliest convenience and greatly oblige.

W. J. E.

ANS.—DEAR SIR:—

Replying to your inquiry of October 11th will say that a license may be exacted from a corporation furnishing water to a town.

Enclosed you will find a copy of Ordinance No. 785, of the City and County of San Francisco, imposing a license on water companies. There is nothing in the general laws prohibiting a city of the sixth class from imposing such a license.

OCTOBER 12, 1910

Q.—GENTLEMEN:—

Is it necessary when calling a special meeting of the Town Trustees, to insert in the written call the purpose of the special meeting?

ANS.—DEAR SIR:—

Your query of the 10th inst. received. We reply thereto as follows:

1st. Sec. 858 of the Municipal Corporations Bill does not specify that the purpose of a special meeting shall be stated in the call.

On the other hand we find in Cyc. 28th Vol. page 329 a statement that "it is essential to the validity of special meetings and of the action taken thereat, that the members be notified of the business to be transacted if it be special or unusual.

Mills vs. San Antonio 65 S. W. 1121

Bergen v. Clarkson 1 Halst, N. J. L. 428

Again, in Whitney vs. City of New Haven it was held that notice of a special meeting need not specify the object thereof.

58 Conn. 450.

It is conceded that decisions on this point are conflicting; it is generally agreed, however, that the proceedings of council meetings should be conducted in accordance with parliamentary law, which would require the purpose of the special meeting to be stated in the call. It is also agreed that if the purpose of the special meeting *is stated in the call*, no other business can be considered.

Q.—GENTLEMEN:

If the time is not already too late, some of us here in our town are going to make a desperate attempt to put this little city on a commission form of government, and I would feel greatly obliged if you would forward me an outline of the procedure necessary to accomplish this step in sufficient detail so that we can go ahead without any further delay.

I presume you are quite familiar with the proceedings and if it is at all possible I would appreciate an immediate reply so that we can introduce this matter at the next meeting of the Board of Trustees which takes place on October 17.

ANS.—DEAR SIR:

Your letter of October 12th received. Replying thereto will say that the first thing necessary is to pass a resolution calling a special election for the purpose of electing a board of fifteen freeholders, who shall have been for at least five years next preceding qualified electors thereof, to prepare and propose a charter for said city. Such special election shall be held not earlier than thirty days from the time of passing the resolution, and it should be conducted in accordance with the ordinances of the City of Whittier and the general election laws of the State of California governing elections.

Define the election precincts in the call, and name the polling places and the election officers. If you consolidate the precincts, provide eight election officers for each, otherwise four will do.

Publish the notice once a week until the election.

Candidates for freeholder should immediately get busy with their petitions to get on the ballot. See Sec. 8, Art. XI of the Constitution of California.

We are sending this in haste as your letter went to Santa Clara and consequently was delayed in delivery. You have time to frame a charter. By no means fail to send delegates to the San Diego convention, as Commission Government for small cities is one of the numbers on the program, and will be discussed by Mr. Baker of Glendale, Mr. Kirkbride of San Mateo, and others.

SEPTEMBER 28, 1910

Q.—GENTLEMEN:

A member of the Board of Trustees of our town has been absent from the town for several months. What proceedings shall we take to declare the office vacant and appoint some one to take his place?

ANS.—If he remains absent from the city for a period of ninety days without permission, the Board of Trustees shall pass a resolution reciting the fact of such absence and declaring the office vacant; after doing this, they shall appoint some citizen to fill the vacancy.

OCTOBER 7, 1910.

Q.—We have a large fill to make at the end of a bridge which will cost about \$3000 if we have to call for bids and let the work out by contract. Can we do the work ourselves at odd times, using city teams? If so, we could save considerable money, as we have to maintain our teams anyway.

ANS.—We regret to say there is no way you can lawfully do the work mentioned except by advertising for bids and letting the job by contract. However, in many cases under similar circumstances the law is disregarded, but there is always a chance that someone may enjoin the payment of the bills.

Q.—Our town is about to do considerable work in the matter of constructing sewers and sidewalks. We intend to proceed under the Vrooman Act, and I would like to know where I can get a copy of the act and a full set of forms of proceedings.



## PACIFIC MUNICIPALITIES

ANS.—DEAR SIR: Replying to your inquiry of October 6th, will say that the latest copy of the Vrooman accompanied by a full set of forms, is the work published by Sidney Dell of Los Angeles, in 1909. We understand his residence is Casa Verdugo, Cal.

Enclosed you will find copies of nearly all the forms required. The Vrooman Act was repealed by the last legislature in so far as it related to the construction of sidewalks, and a separate act passed for sidewalk construction. Further amendments will undoubtedly be made by the coming legislature. However you may proceed with the construction of your sewers under the Vrooman Act. Proceedings under both acts must be conducted with extreme care, as an apparently trifling error will invalidate everything, and you will have all the trouble for nothing. (See the 1910 Edition of the General Laws for both acts in full).

Q.—We contemplate macadamizing a street about one mile long and doing the work under the Vrooman Act. In one portion of the street the roadbed is thirty feet wide; in another it is not more than twenty-four feet. The question with us, is whether or not the assessment against any specific lot should be determined by its frontage on the street, or should the fact that it fronts on the portion of the street which is to have but a twenty-four foot roadbed be taken into consideration in fixing the assessment which such a lot should pay.

It appears to me from the reading of the above subdivision that the assessments should be made according to the frontage, regardless of the width of roadbed which may be laid before any specific lot.

ANS.—DEAR SIR:

Your inquiry of September 27th at hand. We believe that your view on the matter is the correct one; that is, the assessments should be made according to the frontage. The point has apparently never been raised in the country.

As a manifest injustice would be done, however, why not do the work under two separate propositions? Another more equitable method would be to make a district which could run back on either side to the depth of the narrowest lot.

Q.—I have been instructed by the Board of Trustees to ask your opinion on the following:

Can the town collect a license from automobiles carrying passengers under Ordinance No. 3, Sec. 7, either those owned in the town or carrying passengers from other towns to this town, but owned outside of the town? Would stages carrying U. S. Mail and passengers be liable for license for carrying passengers? Is section 3 of this Ordinance legal?

ANS.—In answer to your first question will say that according to the provisions of Section 4 of Act 2331, you are forbidden to impose any license tax on automobiles. You may impose a license tax on other vehicles, including stages.

Section 3 of your ordinance is defective. As it reads now, you may collect a license tax from liquor dealers only. It should be corrected as shown in the enclosed copy.

## What the Cities are Doing

**Bakersfield** has just joined the League.

**Visalia** has accepted the new fire alarm system recently installed.

**Sonoma** streets are being piped for a new water system.

**Orange** has disposed of its \$16,000 ontfall sewer bonds, also its \$5000 paving bonds. The lateral sewers will be put in under the Vrooman Act.

**Monrovia** just voted \$120,000 sewer bonds and \$5000 water bonds.

**Whittier** would like to try the commizion plan of government and will elect freeholders to frame a suitable charter.

**Pasadena** has awarded a contract for building an addition to the city hall.

**Vallejo** freeholders are now working on a new charter.

**San Mateo** has commenced a lot of street and sidewalk improvement.

**Santa Paula** sold its \$45,000 5 per cent sewer bonds, receiving a premium of \$1125. There were six bidders.

**Ventura.** The county board rejected all the five bids for the \$75,000 union high school 5 per cent bonds. The highest bid received was par and a premium of \$2260.00 from the State Board of Examiners. The bonds will be offered again in January.

**Modesto** sold its \$100,000 bonds for par and a premium of \$4,080.00.

**Porterville** sewer system is being rapidly installed.

**Richmond.** Contracts to the amount of \$38,000 for street work on the Brown-Andrade subdivision in this city have been recently let.

**Alameda** has a new ordinance which provides that all house connections with sewers shall be made by the city, under supervision of the street superintendent. This was enacted by reason of the poor work done by private contractors in restoring the streets.

**Petaluma** freeholders are working on their new charter.

**Modesto** has awarded the contract for its new pumping machinery to the Frederick C. Roberts Company of San Francisco.

**Ukiah** is to have its Court House improved with a coat of paint.

**Oakland** has commenced actual work on its great scheme of harbor improvement.

**Sacramento** is having its ordinances codified.

**Beaumont,** Riverside County, wants to be incorporated as a city of the sixth class.

**Porterville** property owners have agreed to pave Mill street from Main to Second street, with class A asphalt pavement.

**Willows** has been selected by the Department of Agriculture as the site for a new Viticultural Experiment Station.

**Long Beach** has awarded the contract for constructing its new Polytechnic School to Lynn L. Atkinson of Los Angeles for \$118,966.00.

**San Jose** has amended its ordinance regulating traffic of vehicles which requires that a person desiring to stop or change his course must first make a visible or audible signal to those in the rear.

**Santa Rosa** has abolished the common drinking cup and public towel from the public schools. Japanese crepe paper is used for towels; they are not only efficient and more sanitary, but cost much less than laundry bills.

**Oakland** is considering a bond issue for establishing a municipal water system.

**Cottonwood,** Shasta County, has installed a water system.

**Claremont** has sold its \$75,000 high school bonds for par and a premium of \$2685.00.

**Sacramento** has a committee preparing a new charter for submission to the legislature in 1913.

**Oakland** is contemplating a bond issue of \$2,250,000 for school buildings and additions.

**Pasadena** is advertising for a band of from 20 to 25 pieces to discourse music during the next six months.

**Hayward** is contemplating a bond issue of about \$12,000 for two additional school buildings.

*Continued on page 165*

# SAVING TIME *by* TELEPHONE



When a man feels the necessity of being in two places at the same time he goes to the nearest telephone and sends his voice. It is not exactly the same thing, but when a man talks hundreds of miles in opposite directions from the same Bell Telephone, it is about as good. In the daily use of the telephone a man travels all over town by wire in a few minutes. It is just as easy to travel all over the state and other states by means of the universal Long Distance Service of the Bell System.



## The Pacific Telephone & Tel. Co.

*Every Bell Telephone is the Center of the System*



TIMKEN BUILDING, SAN DIEGO



# The Timken Building

San Diego's Most Magnificent Store and Office Structure



The Timken Building is the handsomest and most prominent store and office building in San Diego. It occupies a frontage of one hundred and twenty-five feet on Sixth street, and one hundred feet on E street, the center of the business district and car line service of the city. It is an eight-story building of reinforced concrete construction thruout, absolutely fire-proof, and modern in all its appointments.

The first floor is designed for stores, all well lighted and rich in appointments. A spacious marble-lined vestibule and lobby gives approach to three elevators exclusive for passenger use, and to the main stairway leading to the upper floors of the building.

The second to eighth floors, inclusive, are devoted to offices. These are reached by elevator and stairway to the spacious and well-lighted corridors from which the offices open. Each office has a vault with steel door and combination lock, a lavatory supplied with hot and cold water, compressed air service, and is also piped for gas. Offices are so arranged that any number of them may be joined "en suite."

The building generally is supplied with steam heat and electric light. The interior finish of the building is birch in rich mahogany color. The building is equipped with sanitary dust-removing plant, and has commodious general lavatories on each floor. The seventh and eighth stories overlook surrounding buildings, and from the windows of these a magnificent view of the surrounding scenery is obtained, especially from the Sixth street front and the south side, both of which overlook Point Loma and the bay.

Freight elevator is on the E street side, and serves the building from the spacious basement thruout the eight stories.

Its projector, the late Henry Timken, took great interest in its construction, sparing no effort to meet all requirements of a strictly first-class modern building.

---

---

**GEORGE BURNHAM & CO.**

AGENTS FOR THE BUILDING. ROOMS 212-214



# EAST

## California Limited

*Exclusively First Class*

One of the finest trains from the  
**Pacific Coast to Denver and Chicago**  
**Through Cars No Changes**

Safe—Block signals, telephone dispatching.

Meals—Perfect. Fred Harvey.

Courteous employes.

Most powerful type motive power—Mallet  
 compound articulated.

## Santa Fe

New—Tourist Flyer

—Fast as the Limited

**OVERLAND EXPRESS**

See the **Grand Canyon of Arizona**

Stopovers permitted to all.

S. C. PAVSON, General Agent,

U. S. Grant Hotel Block

# SANTA FE

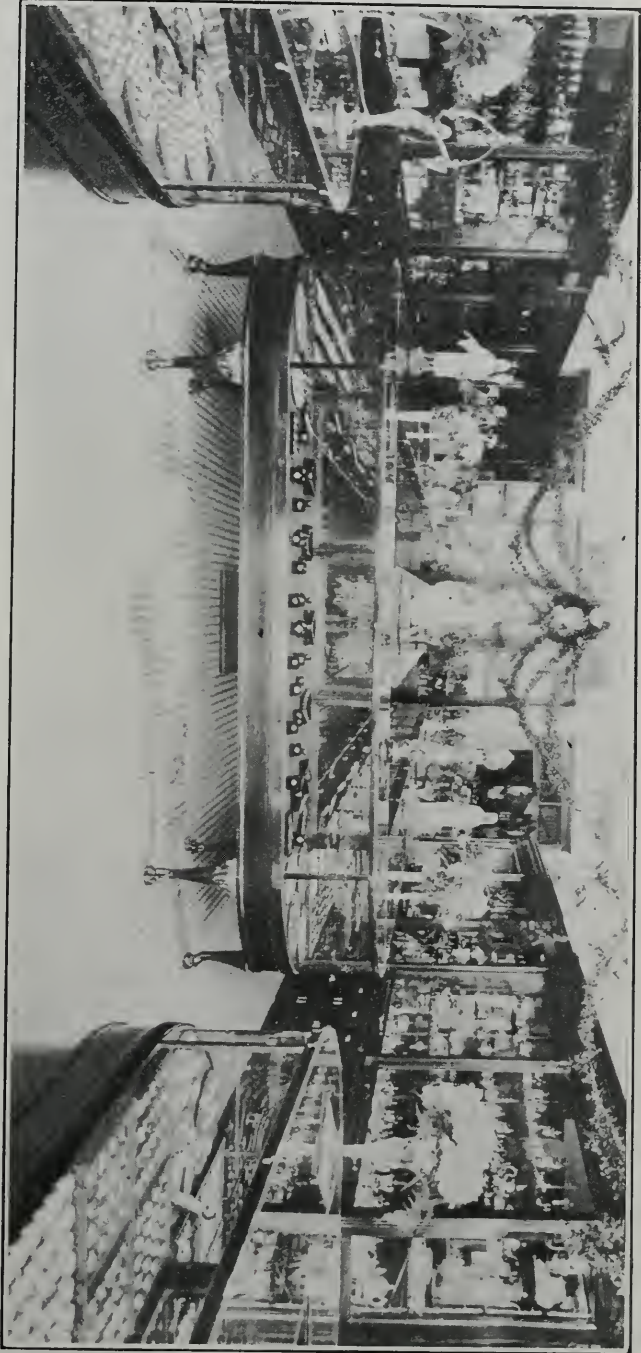

Mr. Frank Schiefel came to San Diego in the year 1900 and at once realized the favorable conditions existing to start a factory for fixtures and show cases. He bought a lot 50x100, built a large two-story factory and with his sons, under the firm of Schiefel & Sons, started in the manufacturing of office, bank, bar, store fixtures and show cases. The plant employs as high as 50 men at this time and turns out the finest equipment in the United States. Nearly all the interiors of the leading firms of San Diego are the work of this plant and above is the interior of a leading jewelry store (Ernstring Jewelry Co.), fixtures designed and installed by this firm. The rapid growth of San Diego and the always increasing demand forced the owners to enlarge their plant and for that purpose they purchased the adjoining lot of the same size, where they will start to build at once to be able to fill their orders. There is no doubt that the manufacturing plant of Schiefel & Sons will always be a credit to greater San Diego.



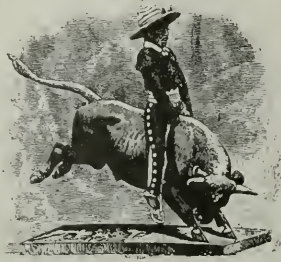

*One of the Sights of the City--*

## Burnell's Curiosity Shop

1415-1417 F Street

Established 1887

Between 5th and 6th Sts.

*Mexican and Indian Curiosities  
California Souvenir Goods  
Native Gem Stones and Pearls*

Navajo Indian Blankets and  
Silver Work

Makers of Hand Carved and  
Art Leather Goods

## Crane's Hotel and Cafe



*New and Elegantly Furnished Rooms*

*Rates \$1.00 per day and up*

*Make Reservations Early*

1127-1129 Fifth Street

San Diego, California

It's the *Water* we use!  
It's the materials we use!  
It's the knowledge we use!  
It's the facilities we use!

which enables us to produce such

**HIGH CLASS BEER**

known as



San Diego Consolidated Brewing Co.



U. S. GRANT HOTEL

ABSOLUTELY FIRE PROOF

# U. S. Grant Hotel

[European Plan]

HEADQUARTERS OF THE CONVENTION

500 Rooms—350 with bath. Single rooms \$1.50 Up;  
with bath \$2.50 Up. *Our 'bus meets all trains and steamships.*

This excellent concrete hostelry was formally opened Saturday evening, October 15th, and we take great pleasure in calling your attention to the above information.

**JAMES H. HOLMES, Managing Director**

Telephone Main 704

Private Boxes for Ladies

## Oyster Loaf Restaurant

S. Solak &amp; G. Topuzes, Proprietors

*The Only Place of the Kind in the City*

**Q**We serve fresh daily Oysters, Clams, Crabs, Shrimps, Lobsters. Fine Steaks, Poultry and Dairy Dishes our Specialties.

1228-1230 C St., Cor. Fourth

San Diego, Cal.

### O'HALLARAN & SLOANE

REALTY BROKERS

Insurance and Notary

1142 D Street

San Diego, Cal.

## • M. HALL • Real Estate •

Established 1886

LOANS AND INSURANCE

1310 D Street

## HAZARD, GOULD & CO.

[Wholesale and Retail Hardware]

desire to announce their

**REMOVAL**

to the Steele Block

### Corner Sixth and H Streets

 Call and see the Largest and Finest Hardware Store in California 

**Q**Send us your shipping receipt and we will deliver your exhibits for San Diego meeting of the League.

### Pioneer Truck Co.

1328 E Street

FRANK P. FRARY, Sec. and Treas. and Past Pres. of the League of California Municipalities

Home Phone 1248    Sunset Main 248

### W. J. BAILEY

Lime, Cement, Lath  
Pressed Brick, Fire  
Brick, Plastering and  
Building Materials.

Foot of F Street, at  
at Railway Crossing

San Diego, Cal.



E. E. SHAFFER  
Home 3061

R. P. MOSES  
Sunset 2738

**Shaffer & Moses**  
**S-M**  
**Electrical Company**

INCORPORATED

Gas and Electric Fixtures  
House Wiring and  
Electrical Engineering

Cor. C and Third Streets

San Diego - - - Cal.

**The Burnap**

Opp. U. S. Grant Hotel

*In every way the most desirable  
Rooming House in San Diego*



Everything new and modern.  
Rooms all large and sunny.  
Single or en suite. Station-  
ery wash stands, gas grates  
in every suite, and baths on  
each floor. Cars from all the  
depots pass the door.

Prices—50c to \$1.50

Special Rates by Week or Month

Cor. 3rd & D Phone Main 345

**The Best Yet**

Private Telephone  
Pacific Main 3732



856 5<sup>TH</sup> ST  
ROMAIN MCKENZIE, MGR.  
SAN DIEGO, CAL.

**[**New modern hotel elegantly fur-  
nished in mahogany, maple and  
walnut. Carpeted floors and large  
comfortable rooms.

**No Inside Rooms**

RATES: 75c and \$1.00 per Day

Block and one-half from Fifth and D  
Street. Take any carriage from  
depot and fare will be refunded.

**Lanier Hotel**

[EUROPEAN PLAN]

Rooms single and en suite.  
Hot and cold running water  
in each room. Phones in  
each room with outside con-  
nections. Home 2438, Pa-  
cific 39. Steam heated and  
private baths.

Rates \$1.00 and Up.

Make Reservations Early

3rd and Ash Sts. San Diego

## LIST OF RESPONSIBLE FIRMS TO BE CALLED ON TO BID FOR PUBLIC WORK OR SUPPLIES

### WRITE FOR CATALOGS

This list is arranged as a guide for the accommodation of city officials where advertising for bids is not necessary.

#### Accountant

William Dolge, C. P. A., 255 California St., S. F.

#### Architects

W. H. Weeks, 251 Kearney St., S. F.

#### Asphalt Machinery

A. L. Young M'chy Co. 26-28 Fremont St., S. F.

#### Arch. Terra Cotta

Gladding, McBean & Co., Crocker Building, S. F.

#### Automobile Public Service Wagons

Consolidated Motor Car Co., Cor. Van Ness and McAllister Sts., S. F.

The Thomas B. Jeffery Co., 117-125 Valencia St., S. F.

#### Bitulithic Pavement

Warren Brothers Company, Los Angeles, Cal.

#### Bridge Builders

Keatinge-Bradford Co., 615 Humboldt Bk Bdg. E. T. Thurston, Jr., Wells, Fargo Bldg., S. F.

#### Concrete Construction

Keatinge-Bradford Co., 615 Humboldt Bk Bdg. Hazelwood, Jones, Doane & Hanscom, 675 Monadnock Building, S. F.

#### Contractors and Builders

Finch Jail Building and Metal Co., 16 California St., S. F.

#### Constructing Engineers

Fred'k C. Roberts & Co., 221 Sheldon Building, S. F.

W. N. Concannon Co., 433-437 Monadnock Building, S. F.

#### Consulting Engineers

Spaulding, Sloan & Robson, 802 Union Trust Building, San Francisco.

E. T. Thurston, Jr., Wells Fargo Bldg., S. F.

#### Drinking Fountains

Haines, Jones & Cadbury Co., 851-859 Folsom St., S. F.

#### Dump Carts and Wagons

A. L. Young M'chy Co., 26-28 Fremont St., S. F.

#### Electrical Plants & Machinery

A. L. Young M'chy Co., Fremont St., S. F. Chas. L. Kiewert Co., 195 Fremont St., S. F.

#### Engravers and Bond Printers

Commercial Art Co., 53 Third St., S. F. Schmidt Lithograph Company, Second & Bryant Sts., S. F.

Sierra Art Engraving Co., Front & Commercial Sts., S. F.

#### Fire Alarm and Police Tel. Systems

Gamewell Fire Alarm Tel. Co., Market and Battery Sts., S. F.

#### Fire Dept. Equipment

Cal. Fire Apparatus Co., Jessie and New Anthony, S. F.

R. S. Chapman, 400 Golden Gate Ave., S. F.

#### Fire Engines

Gorham Rubber Co., 50-56 Fremont St., S. F.

#### Fire Extinguishers

Goodyear Rubber Co., 589 Market St., S. F.

#### Fire Hose

Gorham Rubber Co., 50-56 Fremont St., S. F. Eureka Fire Hose M'fg Co., 610 Postal Tel. Building, S. F.

New York Belting & Packing Co., 129-131 First St., S. F.

#### Gasoline Engines

Doak Gas Engine Co., 7-9 First St., S. F.

#### Lithographers

Schmidt Lithograph Company; Second & Bryant St., S. F.

#### Metal Furniture

Finch Jail Building and Metal Co., 16 California St., S. F.

Art Metal Construction Co., Flood Bldg., S. F. Story Building, Los Angeles.

#### Municipal Accountant

William Dolge, C. P. A., 255 California St., S. F.

#### Municipal Lawyers

Mason & Locke, 904 Pacific Building, S. F.

#### Municipal Printers

A. Carlisle & Co., 251-253 Bush St., S. F.

#### Municipal Pumping and Water Service

Fredk. C. Roberts & Co., 461 Market St., S. F.

#### Pavement Materials

Warren Brothers Company, Los Angeles, Cal.

#### Playground Apparatus

A. L. Young Machinery Co., S. F.

#### Reinforced Oil Concrete Streets

E. M. Chadourne Co., 800 Postal Tel. Building, S. F.

#### Road Machinery

J. I. Case Threshing Mch. Co., 616 Myrtle St., Oakland, Cal.

Henshaw, Bulkeley & Co., Fremont St., S. F.

A. L. Young M'chy Co., Fremont St., S. F.

Petrolithic Pav. Co., 209 E. 7th St. Los Angeles

#### Safes

Cary Safe Co., 669-671 Mission St., S. F.

Parcells Safe Co., 577 Market St., S. F.

Victor Safe & Lock Co., 1292-4 Market St. S. F.

#### Scrapers

A. L. Young M'chy Co., Fremont St., S. F. Petrolithic Pav. Co., 209 E. 7th St., Los Angeles.

#### Sewer Pipe and Terra Cotta

Gladding, McBean & Co., Crocker Bldg, S. F. Steiger Terra Cotta Co., Mills Bldg., S. F.

#### Street Signs

A. L. Young Mch. Co., S. F.

#### Street Sweepers

A. L. Young M'chy Co., Fremont St., S. F.

#### Structural Steel Riggers

C. A. Blume Construction Co., 185 Stevenson St., S. F.

#### Valuts

Cary Safe Co., 669-671 Mission St., S. F.

Parcells Safe Co., 577 Market St., S. F.

Victor Safe & Lock Co., 1292-4 Market St., S. F.

#### Water Supply

Doak Gas Engine Co., 7 and 9 First St., S. F.

**What the Cities Are Doing.—Continued**

**Sacramento** supervisors have received the amended plans and specifications for the proposed new Court House.

**Stockton** will vote on \$100,000 bonds for fire department; \$77,000 for sanitary sewers; \$40,000 for rainwater sewers, and \$228,000 for street improvements.

**Yreka** is about to construct a reinforced concrete bridge over Humbung Gulch, on Oregon street.

**Chico** is about to construct a reinforced concrete bridge over Little Chico creek on Broadway.

**Corning** votes \$70,000 bonds for sewer and water systems.

**Lindsay** has applied for membership in the League.



**“HYGENIC” DRINKING FOUNTAIN**

For Schools, Railway Stations, etc. Prevents contagion and provides each user with an ample supply of fresh water.

Illustrated circular sent on request.

The newest things in plumbing fixtures for Schools, Factories and Office Buildings are on display in our Show Rooms.

851-859 Folsom Street, San Francisco, Cal.

Phones, Sutter 1130; Home J-2110

**Haines, Jones & Cadbury Co.**

Makers of Plumbing Supplies

1130-1144 Ridge Avenue, Philadelphia

Branches—Savannah and San Francisco

E. W. Haselwood, Assoc. M. Am. Soc. C. E.

Sidney Jones

E. W. Doane

W. A. Hanscom

**Haselwood, Jones, Doane & Hanscom**  
*Civil, Hydraulic and Sanitary Engineers*

***Sewers, Waterworks, Light Plants, Street Work and Bridges***

Phone Sutter 1337

675-677 Monadnock Building

SAN FRANCISCO, CAL.

**E. T. THURSTON, Jr.**

Assoc. M. Am. Soc. C. E.

**Consulting Engineer**

713 Mechanics' Institute

Phones Sutter 1683 and C 2895

SAN FRANCISCO

**Specialties**

Design and Supervision of Buildings, Bridges, Railways, Water Works and Municipal Work

**Concrete Bridges**

Exclusive rights under patents of National Bridge Company, the largest in the world.

Estimates furnished free of charge.

**C. A. BLUME CONSTRUCTION CO.**

Members of Builders Exchange

**Structural Steel Riggers**

Phone Douglas 324

185 STEVENSON STREET

SAN FRANCISCO

**W. N. CONCANON CO.**

**Constructing Engineers**

Foundations, Reinforced Concrete, Steel and Concrete Buildings and Bridges

General Engineering Work. Special Attention Given to Public Work

433-437 Monadnock Bldg.

Phone Kearny 2884.

681 Market St.

SAN FRANCISCO, CAL.



The  
Bitulithic  
Pavement  
For Streets  
and Roads



Year	Miles	Cities
1902	22	33
1903	52	40
1904	59	45
1905	59	42
1906	85	57
1907	109	66
1908	95	62
1909	118	74
<b>TOTAL</b>	<b>679</b>	<b>216</b>

**TOTAL MILES (30 Ft. Road)**

Combines the inherent stability of the mineral aggregate with the cementing qualities of the asphaltic oil, or other bituminous cement, and produces a smooth, dustless, waterproof pavement, suitable for automobile traffic and driving--prevents skidding and affords a good foothold for horses--is COVERED BY PATENTS, the VALIDITY of which has been SUSTAINED BY THE SUPREME COURT OF THE UNITED STATES.

Send for circulars showing where used and methods of construction.

**WARREN BROTHERS COMPANY**

Portland, Ore.

Boston, Mass.

Los Angeles, Cal.

616 Laughlin Bldg.

REGISTERED TRADE MARKS

"Bitulithic" "Warrenite" "Puritan" "Bitrock" "Bituminous Macadam" "Biustone"

**MAPS**  
**BONDS**  
**STATIONERY**  
**BOOKLETS**  
**POSTERS**  
**LABELS**  
**CARTONS**  
**ETC.**

**SCHMIDT LITHOGRAPH COMPANY**

MAIN OFFICE  
SAN FRANCISCO.

PORTLAND      LOS ANGELES

**FINCH JAIL BUILDING AND METAL CO.**

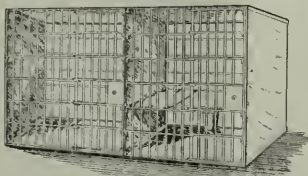

Manufacturers and Builders of

**PRISON CELLS AND ALL APPURTENANCES.**

Dealers in Metal Furniture and Fixtures

Office No. 16 California St.

Telephone Kearney 935

**WILLIAM DOLGE**

*Certified Public Accountant --- Municipal Accountant*

TELEPHONE DOUGLAS 5173

255 California Street

San Francisco, Cal.

**WM. H. WEEKS, Architect**

PUBLIC BUILDINGS A SPECIALTY

251 Kearney Street

San Francisco

**SPALDING, SLOAN & ROBSON  
CONSULTING ENGINEERS**

Waterworks, Sewer Systems, Paving, Lighting Plants

Telephone Kearney 4646

802 Union Trust Building, SAN FRANCISCO

Chas. P. Bradford, President

M. Keatinge, Vice-Pres. and Supt.

Howard J. Van Kirk, Secretary

**KEATINGE-BRADFORD COMPANY**

Concrete Contractors and General Contractors

Telephone, Kearny 2921

Room 615 Humboldt Bank Building

SAN FRANCISCO

**GORHAM RUBBER CO.**

RUBBER GOODS OF EVERY DESCRIPTION

Fire Hose, Chemical Engines, Hose Carts, Packing

**50-56 Fremont St., San Francisco**

W. J. LOCKE

H. A. MASON

**Mason & Locke**

ATTORNEYS AND COUNSELORS AT LAW

*Bond proceedings conducted---validity and sale guaranteed*

Ninth Floor Pacific Building

SAN FRANCISCO

# Henshaw, Bulkley & Co.

## ROAD MACHINERY

### A SPECIALTY

19-21 Fremont Street  
San Francisco

262-264 So. Los Angeles St.  
Los Angeles

# The Commercial Art Co.

INCORPORATED

## Designers & Engravers

53 Third Street

San Francisco

TERRA COTTA, PRESSED BRICK, PIPE,  
FIRE PROOFING, ROOFING TILE,  
FLUE LININGS, FIRE TILE,  
LAUNDRY TRAYS,  
ETC.

**GLADDING, McBEAN & CO.**

WORKS  
LINCOLN, CAL.

--- OFFICE ---

311-317 CROCKER BLDG., SAN FRANCISCO.

# Steiger Terra Cotta and Pottery Works

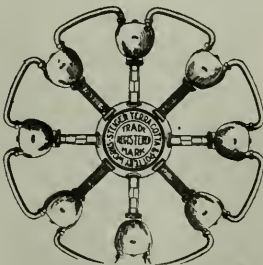

MAIN OFFICE AND YARDS:

City Yard, 18th and Division Streets

Main Office: 729 Mills Building  
Phone Douglas 3010

SAN FRANCISCO, CAL.

Factory, South San Francisco  
San Mateo County



# SPECIAL BARGAINS IN THE BEST MAGAZINES

1. Review of Reviews - - \$3.00 } <b>All For</b>	2. Review of Reviews - - \$3.00 } <b>All For</b>
American Magazine - - 1.50 } <b>\$3.25</b>	Woman's Home Companion 1.50 } <b>\$3.50</b>
Sunset Magazine - - 1.50 }	Sunset Magazine - - 1.50 }
3. American Magazine - - \$1.50 } <b>Both For</b>	4. Woman's Home Companion \$1.50 } <b>Both For</b>
Sunset Magazine - - 1.50 } <b>\$2.00</b>	Sunset Magazine - - 1.50 } <b>\$2.25</b>
5. American Magazine - - \$1.50 } <b>All For</b>	6. Technical World - - \$1.50 } <b>Both For</b>
Woman's Home Companion 1.50 } <b>\$2.75</b>	(or World Today)
Sunset Magazine - - 1.50 }	Sunset Magazine - - 1.50 } <b>\$2.35</b>
7. Forest and Stream - - \$3.00 } <b>Both For</b>	8. Van Norden's - - \$1.50 } <b>Both For</b>
Sunset Magazine - - 1.50 } <b>\$3.00</b>	Sunset Magazine - - 1.50 } <b>\$2.00</b>
9. Forest and Stream - - \$3.00 } <b>All For</b>	10. American Magazine - - \$1.50 } <b>All For</b>
Womans Home Companion 1.50 } <b>\$3.50</b>	Technical World - - 1.50 } <b>\$2.75</b>
Sunset Magazine - - 1.50 }	Sunset Magazine - - 1.50 }
11. Review of Reviews - - \$3.00 } <b>All For</b>	12. McClure Magazine - - \$1.50 } <b>Both For</b>
Van Norden's Magazine 1.50 } <b>\$3.10</b>	Sunset Magazine - - 1.50 } <b>\$2.35</b>
Sunset Magazine - - 1.50 }	
13. Scientific American - - \$3.00 } <b>Both For</b>	14. Review of Reviews - - \$3.00 } <b>At Half Price</b>
(New subscriptions only)	American Magazine - - 1.50 } <b>All For</b>
Sunset Magazine - - 1.50 } <b>\$3.00</b>	Woman's Home Companion 1.50 } <b>All For</b>
	Technical World - - 1.50 } <b>\$5.25</b>
	Van Norden's Magazine 1.50 }
	Sunset Magazine - - 1.50 }

## *Sunset Magazine, \$1.50 the Year*

**CLUBS** may be split to go to different addresses.

**FREE** with each order, two beautiful four color pictures of Yosemite Valley, ("El Capitan" and "Vernal Falls") handsomely mounted. These pictures will be sent flat, not rolled.

**POSTAGE** to Canada is 50 cents extra on each magazine; to foreign countries is \$1.00 extra.

### SUNSET MAGAZINE FOR 1910 INCLUDES

- (1) A California novel "The Rules of the Game" by Stewart Edward White—to be run as a serial.
- (2) Mexico Today—a series of articles of great interest, by one high in authority in our sister republic.
- (3) Alaska and the Alaskans, by Governor Walter E. Clark.
- (4) The best fiction by such authors as Jack London, Billie Glynn, Eleanor Gates, Dave Coolidge, James Hamilton Osborne, etc.

And many other special features.

ADDRESS

## SUNSET MAGAZINE

313 Battery Street

San Francisco

# MUNICIPAL AND CONTRACTORS' MACHINERY

...FOR...

## GOOD ROADS AND STREETS

Street Signs  
National Road Machines  
Fort Wayne Road Machines  
Indiana Road Machines  
National Elevating Graders  
Elevators—Portable Bunkers  
Shares or Cutting Edges for all types of Road Machines  
Rock Crushers, Jaw and Gyratory Type, mounted and unmounted  
Screens  
Steam Road Rollers  
Horse Rollers  
Scarifiers  
Harrows for oiled roads  
Wheeled and Drag Scrapers  
Fresno Scrapers  
Reversible Road Plows  
Street Sprinklers  
Sprinkling Attachments  
Street Sweepers  
Fibre for Street Sweepers  
Patent Dump Wagons  
Asphalt Machinery  
Kettles—Hand Rollers—Tampers  
Concrete Mixers  
Hoisting Engines  
Playground Apparatus  
Culvert Pipe

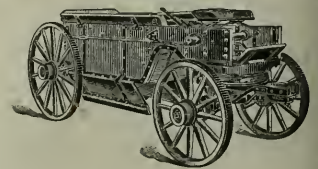
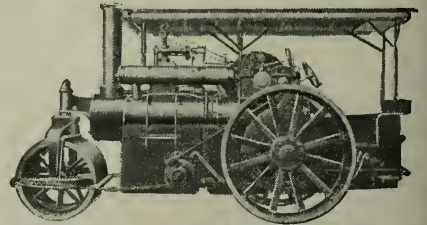

Write us for Catalogues and Estimates

## A. L. Young Machinery Co.

26-28 Fremont Street

San Francisco

California

# PACIFIC MUNICIPALITIES

THE CITY BEAUTIFUL



PUBLIC  
SAFETY  
HEALTH  
CONVENIENCE

PUBLIC  
UTILITIES  
EDUCATION  
RECREATION

PUBLISHED MONTHLY

SIERRA S.F.



## WE WANT YOU TO KNOW

Thanksgiving Day automobile races over the Santa Monica course show this to be the fastest motor road in the country. The Lozier car made 151½ miles at the rate of 73.25 miles per hour, and 202 miles at 71.42 miles per hour. This course is almost entirely a **dirt Petrolithic** road at least five years old, and was not built for a race course. We can build better roads with the Petrolithic Rolling Tamper now than we built five years ago. We want you to know details of Petrolithic Macadam construction.

## PETROLITHIC PAVEMENT CO.

336 Pacific Electric Bldg., Los Angeles, Cal.

### SILENT

### LUXURIOUS

### 3 MODELS

THE NEW  
*Rambler*

Touring Cars, Motor Fire Trucks, Chemical, Hose,  
Police Patrol and Ambulances a Specialty.

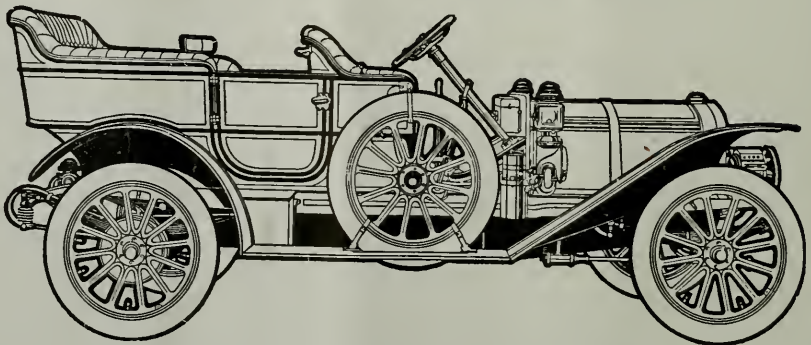

### The Thomas B. Jeffery Co.

117-125 Valencia St.

WRITE FOR INFORMATION.

San Francisco

# CASE LINE...

Municipal Hauling Engines  
 Contractors' General Purpose Engines  
 Steam Steered Road Rollers  
 12 @ 16 Bbl. Mounted Fuel and Water  
 Engine Tenders for Engines and  
 Road Rollers  
 Troy Bottom Dump Wagons  
 Road Graders  
 Road Scrapers  
 Road Routers and Road Drags

Write for our general catalog "M." Address Road Machinery Department.

**J. I. CASE THRESHING MACHINE COMPANY, Inc.** RACINE, WIS.,  
 U. S. A.

BRANCH OFFICE, 616 MYRTLE ST., OAKLAND, CAL.

Insure your Valuable  
 Papers with

## Parcells Safe Co.

AGENTS

"Diebold" Safes and "Allsteel" Metal Furniture

577 MARKET STREET

SAN FRANCISCO

## A. CARLISLE & CO.

**Stationers, Printers and Bookbinders**



We specialize in Bonds, Steel Die, Lithographed or Printed, for  
 Municipalities or Counties, and the Books and Forms  
 required by all Municipal Officers.

251-253 Bush Street

San Francisco, Cal.

# Henshaw, Bulkley & Co.

## ROAD MACHINERY

### A SPECIALTY

19-21 Fremont Street  
San Francisco

262-264 So. Los Angeles St.  
Los Angeles

# The Commercial Art Co.

INCORPORATED

## Designers & Engravers

53 Third Street

San Francisco

TERRA COTTA, PRESSED BRICK, PIPE,  
FIRE PROOFING, ROOFING TILE,  
FLUE LININGS, FIRE TILE,  
LAUNDRY TRAYS,  
ETC.

**GLADDING, McBEAN & CO.**

WORKS  
LINCOLN, CAL.  
--- OFFICE ---  
311-317 CROCKER BLDG., SAN FRANCISCO.

# Steiger Terra Cotta and Pottery Works

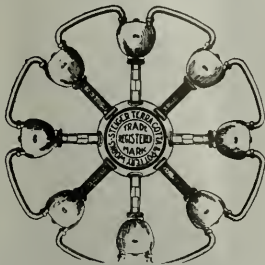

MAIN OFFICE AND YARDS:

City Yard, 18th and Division Streets

Main Office: 729 Mills Building  
Phone Douglas 3010

SAN FRANCISCO, CAL.

Factory, South San Francisco  
San Mateo County



NOTE—Every city official in California reads Pacific Municipalities.

# Pacific Municipalities

OFFICIAL ORGAN OF THE LEAGUE OF CALIFORNIA MUNICIPALITIES

Entered at Post Office, Santa Clara, Cal., as Second-Class Matter

---

VOL. XXIII

TWELFTH YEAR

No. 4

---

EDITORS - - - H. A. MASON AND WM. J. LOCKE

EDITORIAL OFFICE - NINTH FLOOR, PACIFIC BLD'G, SAN FRANCISCO

PUBLICATION OFFICE, - - - SANTA CLARA, CALIFORNIA

---

## CONTENTS FOR NOVEMBER, 1910

---

Letter to City Officials	173
A Comment in the Convention	174
Delegates in Attendance	175
Secretary's Annual Report 1909-10	177
Auditing Committee's Report	179
Resolutions Adopted at the San Diego Convention	180
Relations With the Public	182
The Exhibit of Parrott & Co	185
Questions and Answers	185
What the Cities are Doing	187
The Man Who Wins	187
Sewer District Bonds	189

---

Published Monthly. Yearly Subscription, \$2.00 in Advance. Single Copies, 25 Cents

ADVERTISING RATES ON APPLICATION

Address all Communications to "PACIFIC MUNICIPALITIES" Pacific Building  
San Francisco, California

# LEAGUE OF CALIFORNIA MUNICIPALITIES

Organized 1897

## — OFFICERS —

President	(Mayor of Berkeley)	BEVERLY L. HODGHEAD
First Vice-President	(Councilman of San Diego)	A. E. DODSON
Second Vice-President	(Mayor of Santa Cruz)	T. W. DRULLARD
Secretary	H. A. MASON	Ass't Secretary - WM. J. LOCKE

## STANDING COMMITTEES

**EXECUTIVE**—Beverly L. Hodghead; H. A. Mason; S. C. Evans, Mayor of Riverside; Percy V. Long, City Attorney San Francisco; W. P. Butcher, City Attorney Santa Barbara.

**LEGISLATIVE**—W. F. Hyde, Palo Alto; J. O. Walsh, San Francisco; J. H. Strait, Redlands; F. H. Allbright, Red Bluff; B. S. Barney, Hanford.

**JUDICIARY**—C. N. Kirkbride, San Mateo; P. G. Sheehy, Watsonville; Stephen G. Long, Long Beach; R. E. Rhodes, Madera; Wm. J. Carr, Pasadena.

**ENGINEERING**—Chris. P. Jensen, Fresno; C. H. Pieper, San Jose; A. P. Noyes, Vallejo; R. C. Tumelty, Stockton; O. E. Stewart, Anaheim.

Secretary's Office and Headquarters of the League, - Pacific Building, San Francisco

## INFORMATION BUREAU

The League of California Municipalities maintains, in connection with the Secretary's Office, an Information Bureau where the officials of the municipalities belonging to the League can secure information on all subjects relating to municipal affairs.

## MEMBERSHIP

Alameda	Lindsay	Riverside
Albany	Livermore	Sacramento
Alhambra	Lodi	San Bernardino
Anaheim	Lompoc	San Buenaventura
Antioch	Long Beach	San Diego
Auburn	Los Angeles	San Francisco
Bakersfield	Los Banos	San Jose
Benicia	Los Gatos	San Leandro
Berkeley	Loyalton	San Luis Obispo
Biggs	Madera	San Mateo
Bishop	Martinez	San Rafael
Black Diamond	Merced	Santa Ana
Burlingame	Mill Valley	Santa Barbara
Calistoga	Modesto	Santa Clara
Chico	Monterey	Santa Cruz
Coalinga	Mountain View	Santa Maria
Colton	Napa	Santa Monica
Colusa	National City	Santa Paula
Compton	Nevada City	Santa Rosa
Coronado	Newman	Sausalito
Corona	Newport Beach	Sebastopol
Covina	Oakland	Selma
Crescent City	Ocean Park	Sierra Madre
East San Jose	Oceanside	Sisson
Elsinore	Orange	Sonoma
Emeryville	Oroville	Sonora
Escondido	Oxnard	South Pasadena
Etna	Pacific Grove	South San Francisco
Eureka	Palo Alto	St. Helena
Fairfield	Pasadena	Stockton
Ferndale	Petaluma	Suisun City
Fort Jones	Piedmont	Susanville
Fresno	Pinole	Tehachapi
Gilroy	Placerville	Tulare
Glendale	Pleasanton	Vacaville
Hanford	Point Arena	Vallejo
Hayward	Pomona	Visalia
Hercules	Red Bluff	Watsonville
Hermosa Beach	Redding	Whittier
Huntington Park	Redlands	Willits
Imperial	Redondo Beach	Winters
Jackson	Redwood City	Woodland
Lakeport	Richmond	Yreka
Lemoore	Rio Vista	

Every city belonging to the League of California Municipalities is entitled to a free copy of this magazine every month for each of its officials; if not received kindly notify the Secretary. See that your City is in the above list.

# PACIFIC MUNICIPALITIES

▲ Journal for Progressive Cities

VOL. XXIII

NOVEMBER 30, 1910

No. 4

## LETTER TO CITY OFFICIALS

HEADQUARTERS

LEAGUE OF CALIFORNIA MUNICIPALITIES

PACIFIC BUILDING

San Francisco, December 1, 1910.

To the Boards of Trustees and City Councils:

A resolution was adopted at the recent convention held in San Diego instructing the Secretary to publish and distribute the full proceedings of the session at the earliest possible moment. This will entail the publication of a book of probably not less than two hundred pages.

Now then, in addition to the regular quota to which all municipalities are entitled, several cities have asked for *extra copies* to distribute to members of their improvement clubs, boards of trade, etc., and it is necessary that all others desiring extra copies should send an order to this office *at once*, as we will go to press as soon as the reporter's notes are ready.

A charge of 25 cts. will be made for each *extra copy*, to assist in defraying the extra cost of publication.

Respectfully,

W. J. Locke,

Managing Editor, Pacific Municipalities.



## A COMMENT ON THE CONVENTION

---

The Thirteenth Annual Convention of the League of California Municipalities has passed into history. It was a successful meeting in every respect. The attendance was larger, the enthusiasm greater, and the program more elaborate than ever before. Illustrating the set talk with stereoptican views is a great improvement. Showing photographs of the work you have done is most convincing. City officials are all Missourians and you have "to show them". Take, for instance, the address of Mr. J. H. Reed, Tree Warden of Riverside. Under any circumstances his talk would have been of great interest, but accompanied by monster photographs of his work, it became many times more interesting and instructive. This innovation will undoubtedly be adopted as a permanent feature of our meetings.

The merits of commission plan of government was the subject of a very warm debate, among the city attorneys. The discussion was led off by Mr. Charles N. Kirkbride of San Matteo and although he had many warm supporters, there were others who were convinced that it is a "fraud, a delusion and a snare."

One of the most important things done by the department of City Attorneys was the appointment of a committee on simplification of the Vrooman Act. The members of the committee are all "live wires" and will undoubtedly accomplish some good results.

The discussions of the "Fly Pest" and "The Pure Milk Crusade", illustrated with moving pictures, were among the most interesting features of the program.

Another address which commanded the closest attention, was the paper by C. W. Koiner on "The Benefits resulting from Municipal Lighting in Pasadena." It was a most convincing argument in favor of "municipal ownership", and from the remarks dropped on the conclusion of his paper, many other cities and towns may soon follow the example of Pasadena.

The illustrated talk by Mr. William Dolge, C. P. A., was another number. Mr. Dolge's reputation as an expert municipal accountant had preceded him and he was given the closest attention throughout his address.

"How to Reduce the Fire Hazard in Municipalities," by Geo. N. Robertson, was another subject which commanded general interest, principally because of the fact that Mr. Robertson represented the Board of Fire Underwriters of the Pacific and they are the people who fix the insurance rates. Mr. Robertson, among other things, called attention to the necessity of more rigid enforcement of building ordinances.

City Attorney Percy T. Long of San Francisco delivered a very interesting address in which he called attention to the proposition of creating a public utilities commission such as they have in Wisconsin, with power to determine the valuation of property of public service corporations and advise and assist in determining the rates to be fixed for service rendered. The suggestion of Mr. Long was approved by the convention by a resolution unanimously adopted and published elsewhere in this number.

The work of the State Board of Health in this convention cannot be passed without a word of special commendation. Under the supervision of their very able Secretary, Dr. Wm. F. Snow, a splendid program was arranged and successfully carried out. There is no doubt but much good will be derived from the work of this department on Health and Sanitation. The importance of cleanliness particularly around stables and in the disposal of garbage, was graphically shown by the aid of moving pictures.

## DELEGATES IN ATTENDANCE

**Anaheim**—V. U. Simpson, State Superintendent; F. W. M. Nebelung, Trustee; G. J. Stack, Trustee; O. E. Steward, City Engineer; C. O. Rust, Trustee; C. L. Becker, Trustee.

**Albany**—Geo. W. Nickerson.

**Alhambra**—R. H. Blackledge, City Engineer; R. M. Wallace, President Board of Trustees.

**Berkeley**—W. F. McClure, Councilman; M. L. Hanscom, Auditor; Beverly L. Hodghead, Mayor; J. J. Jessup, City Engineer; J. J. Benton, Health Officer; C. F. Wieland, President Park Commission.

**Burlingame**—F. W. Waggoner, City Engineer; Bert Davis, Trustee; August Berg, Trustee.

**Colton**—Seth Hartley; J. A. Champion, Health Officer; R. J. Martin, President Board of City Trustees.

**Corona**—M. Terpening, City Clerk; A. B. Tutthill, Street Superintendent.

**Covina**—E. P. Warner; F. W. Gail; John N. Wilson, Trustee.

**Coronado**—Geo. Holmes, Trustee; Andrew Ervast, City Engineer; R. Lorini, Health Officer.

**Coalinga**—H. S. Warner, Health Officer; A. E. Webb, Mayor; W. R. Odum, City Clerk.

**Chico**—Wm. Robbie, Mayor; M. C. Polk, Engineer.

**Colusa**—A. B. Jackson, City Clerk; J. H. Sherer, Trustee.

**Escondido**—W. H. Baldrbridge, President Board of Trustees.

**Fresno**—Thos. O. Thorn, Street Superintendent; Chris. P. Jensen, City Engineer.

**Glendale**—G. B. Woodberry, City Clerk; Edward M. Lynch, Engineer and Street Superintendent; Frederick Baker, Attorney.

**Hanford**—Z. D. Johns, Street Superintendent; R. W. Musgrave, Health Officer; B. L. Barney, President Board of Trustees.

**Hermosa Beach**—George Nelson, City Engineer; Theo. H. Hanneman, President Board of Trustees.

**Hayward**—Chas. W. Heyer, President Board of Trustees; Clyde M. Reese, City Clerk.

**Los Banos**—H. C. M. Reutter, Mayor.

**Long Beach**—Stephen G. Long, City Attorney; Dr. W. H. Neuman, Health Officer; Ira S. Hatch, C. O. Boynton, City Clerk.

**Lemoore**—J. H. Brothers, Mayor; R. A. Moore.

**Los Angeles**—T. M. Powers, Health Officer; H. W. Sessions; Dana W. Bartlett.

**Los Gatos**—Geo. W. Turner, President Board of Trustees.

**Merced**—John Czerny, Superintendent of Streets; S. C. Cornell, President Board of Trustees; Dr. W. E. Tilley, Health Officer.

**Madera**—Raleigh E. Rhodes, City Attorney; Dr. Mary Ryerson Butin, Health Officer.

**Monrovia**—R. D. Adams, Health Officer.

**Modesto**—S. W. Coffee, Trustee.

**Newport Beach**—Albert Hermes, City Marshal and Street Superintendent; A. N. Smith, President Board of Trustees.

**National City**—Geo. W. Grant, City Clerk; E. Thelen, Trustee.

**Oceanside**—Geo. E. Morris, President Board of Trustees; F. L. Marten, Health Officer; H. D. Brodie, City Clerk.

**Orange**—Adolph Dittmer, President Board of Trustees.

**Oakland**—P. F. Brown, Assistant City Engineer.

**Pomona**—F. P. Firey, Mayor.

**Pasadena**—J. P. Wood, City Attorney; William J. Carr, Assistant City Attorney; Stanley P. Black, M. D., Health Officer; D. D. Kellogg, Auditor; C. W. Koiner, Gen'l Manager Municipal Lighting Plant; John Beyer, Street Superintendent; S. J. Van Ornum, City Engineer.

**Petaluma**—R. Woods, Trustee; E. S. Shaver, Street Superintendent; M. Walsh, Trustee; J. A. Peoples, City Clerk.

**Piedmont**—Hugh Craig, President Board of Trustees.

**Palo Alto**—W. F. Hyde, Councilman.

**Riverside**—S. C. Evans, Mayor; A. P. Campbell, City Engineer; W. V. Darling, Superintendent of Streets; George E. Tucker; L. C. Waite, Councilman.

**Redwood City**—Albert Mansfield, City Attorney; A. Miles Taylor, President Board of Health.

**Redlands**—J. J. Prendergast, Trustee; Chas. E. Gill; R. M. Cheesman, Trustee; Geo. S.

Hinkley, City Engineer; Charles H. Clock, Trustee; J. H. Strait, President Board of Trustees; Hamilton Toriene, Health Officer; M. W. H. Williams, Trustee; R. Warren Thomas, City Clerk; M. E. Armstrong, Building Inspector.

**Red Bluff**—F. H. Allbright, Trustee.

**Richmond**—Chas. R. Blake, Health Officer; E. J. Garrard, Councilman; Harry D. Chapman, City Engineer and Street Superintendent; Lee D. Windrem, City Attorney.

**Santa Ana**—C. R. Ward, Superintendent of Streets; Ed. Tedford, City Attorney; Ransom Reid, Superintendent of Water and Sewers; John McFadden, Trustee; R. G. Thompson, Trustee; C. W. McNaught, Trustee.

**San Bernardino**—Ralph E. Swing, City Attorney; J. G. Ham, Health Officer; S. W. McNabb, Mayor; D. C. Strong; L. R. Lathrop, Street Superintendent; J. J. Hanford.

**Stockton**—O. Wright, Street Superintendent; Henry Eshbach, Councilman; L. F. Kuhn, City Clerk; M. Brisco, Councilman; Joe Gall, Councilman; Burrel Armstrong, Councilman; Dennis J. O'Keefe, Councilman; R. C. Tummely, City Engineer.

**San Francisco**—H. A. Mason; J. Emmet Hayden, Supervisor; J. O. Walsh, Supervisor; Timothy B. Healy, Supervisor; Paul Bancroft, Supervisor; Percy V. Long, City Attorney; Dr. W. F. McNutt, Health Officer; Ernest J. Mott, Official Reporter; William Dolge, C. P. A.

**San Diego**—W. R. Andrews, City Attorney; John L. Selton, Superintendent Department of Police; Percival E. Woods, Superintendent Finance; Grant Conard, Mayor; A. E. Dodson, President City Council. Frank A. Salmons, Superintendent Department of Streets; Louis Almgren, Jr., Fire Chief; Major H. D. Fay, Superintendent Department of Water; E. M. Capps, Engineer.

**San Luis Obispo**—P. A. H. Arata, City Trustee.

**Santa Cruz**—T. W. Drullard, Mayor; Hugh R. Osborn, City Attorney; J. L. Wright, City Clerk; C. H. Anderson, M. D., Health Officer.

**Santa Barbara**—W. P. Butcher, City Attorney; Alfred Davis, City Clerk; Fred L. Johnson, City Engineer; T. A. Stoddard, M. D., Health Officer.

**San Mateo**—C. W. Melvin; Charles N. Kirkbride, City Attorney; C. M. Morse, City Trustee.

**Santa Maria**—Thomas Preisker, City Attorney.

**San Leandro**—Wm. J. Locke; Fred Schmidt, City Trustee; M. J. Andrade, City Trustee.

**San Jose**—Theo. Brohaska, Councilman; A. L. Whitman, Councilman; J. E. Robinson, Councilman; Walter G. Mathewson, Councilman; C. H. Pieper, City Engineer.

**Sonoma**—M. E. Cummings, President Board of Trustees.

**Sierra Madre**—C. W. Jones, Mayor; R. H. Mackerras, Health Officer.

**Santa Rosa**—Dr. S. S. Boyle, Health Officer.

**South Pasadena**—Ben. F. Dupuy, City Engineer.

**Tulare**—C. L. Smith, City Trustee; H. C. Heitzeg, Mayor.

**Ventura**—Edwin Isensee, City Clerk; F. P. Shaw, Mayor.

**Visalia**—A. R. Orr, Mayor; Fred Osburn, Street Superintendent.

**Vallejo**—Geo. A. Tripp, City Trustee; A. P. Noyes, City Engineer.

**Whittier**—J. B. Chaffey, City Trustee; Dr. W. H. Stokes, Health Officer; D. Reid, Mayor; Walter E. Butler, City Clerk; John C. Stevens, Street Superintendent; R. E. Coppock, Trustee; Geo. Flanders, Trustee.

**Winters**—T. H. Finley, City Trustee.

**Watsonville**—H. B. Kitchen, City Engineer; S. W. Coffman, City Clerk; Phil J. Sheehy, City Attorney.

## ADDITIONAL DELEGATES TO THE DEPARTMENT OF HEALTH AND SANITATION

William F. Snow, Secretary California State Board of Health, Sacramento; Dr. Wm. Simpson, Health Officer, Santa Clara County; J. H. Kuser, M. D., Health Officer, Marin County; N. G. Baker, Engineer and Inspector State Board of Health, Sacramento; Chas. C. Browning, M. D., Los Angeles; C. W. Bornjuge, M. D., Los Angeles; Charles Gilman Hyde, University of California, Berkeley; Ernest B. Hoag, University of California, Berkeley; Dr. Rupert Blue, San Francisco; J. J. Benton, M. D., Berkeley; Frank H. Olmstead, Los Angeles; Frank A. Lathrop, Los Angeles.

## THE FOLLOWING LADIES AND GENTLEMEN WERE REGISTERED AS SPECTATORS

E. J. Murphy, Mayor, Pendleton, Oregon; Mrs. E. J. Murphy, Pendleton, Oregon; J. F. Selig, Publicity Manager of Pacific Municipalities, official organ of the League of California



Municipalities; Wm. B. Gester of Robert W. Hunt & Co., San Francisco; Emory Smith of Smith, Emery & Co., San Francisco; J. P. de Mattos, Mayor, Bellingham, Washington; Mrs. H. A. Mason, San Francisco; Mrs. A. R. Orr, Visalia; Mrs. Edwin Isensee, Visalia; Mrs. J. J. Prendergast, Redlands; Miss Gill, Redlands; Mrs. J. J. Hanford, San Bernardino; Mrs. D. Reid, Whittier; Mrs. Walter G. Mathewson, San Jose; Mr. J. A. Peoples, Petaluma; Mrs. E. J. Mott, San Francisco; Mrs. I. S. Hatch, Long Beach; Miss Minnie Hatch, Long Beach; Mrs. J. Emmet Hayden, San Francisco; Mrs. C. W. Melvin, San Mateo; Mrs. Lee D. Windrem, Richmond; Mrs. Stanley P. Black, Pasadena; Mrs. S. C. Cornell, Merced; Mrs. C. H. Anderson, Santa Cruz; Mrs. R. H. Mackerras, Sierra Madre; Mrs. A. J. Meidroth, Los Angeles; Mrs. D. G. O'Keefe, Stockton; Mrs. L. F. Kuhn, Stockton; Mrs. M. Brisco, Stockton; Mrs. Ella Reid, Stockton; Mrs. J. N. Wilson, Covina.

**THE FOLLOWING WERE PRESENT REPRESENTING THE EXHIBITORS IN THE MUNICIPAL EXPOSITION CONNECTED WITH THE CONVENTION**

A. L. Young, San Francisco, of the A. L. Young Machinery Company; E. P. Conway of the Reinforced Concrete Pipe Co., Los Angeles; J. W. Chute, Berkeley, of the Decarie Incinerator Company; D. Basil W. Alexander (Pacific Coast Chemist) of the Barber Asphalt Paving Company; O. O. Farmer, General Superintendent The Barber Asphalt Paving Company; A. F. Postle, Petrolithic Pavement Company, Los Angeles; Lewelyn J. Allen, Special Belgian Blocks, San Diego; J. Ed. Murphy, Sterling Refuse Destructor, London, England; E. C. Campbell, California Corrugated Culvert Company, Los Angeles; N. W. Howard, Parrott & Company, Los Angeles; M. R. Newman, West Disinfecting Co., New York; R. C. Force, California Corrugated Culvert Co., Los Angeles and West Berkeley; Ralph Steward, J. I. Case T. M. Co., A. J. Meidroth, Los Angeles Paving Brick Co.; S. S. Smith, Henshaw Bulkley & Co., San Francisco and Los Angeles; B. J. Gallagher, Vallejo Brick and Tile Co., San Francisco; S. M. Kennedy, Southern California Edison Co.; Los Angeles; G. E. Hazard, Burroughs Adding Machine Co.; E. A. Harahan, A. Carlisle & Co., San Francisco; Frank Reese, Warren Brothers Company; M. Davis, The Raychester Co., San Francisco; G. H. Brown, The Brown Gasket Co., San Francisco; Samuel Hubbard, Vallejo Brick and Tile Co., San Francisco; E. J. Judah, Parrafine Paint Company, Los Angeles and San Francisco; George P. Griffith, Fairchild-Gilmore-Wilton Company, Los Angeles; B. G. Doak, Doak Sheet Metal Co., Los Angeles and San Francisco, C. C. Kolb, Bitumized Brick and Tile Company, Los Angeles; C. C. Abbott, Triumph Voting Machine Co.

Number of cities represented	sixty-five.
Number of delegates in attendaace	195
Number of ladies and spectators registered	31
Number of exhibitors	28
Additional delegates to Dept. of Health and Sanitation	12
<b>Total</b>	<b>266</b>



**SECRETARY'S ANNUAL REPORT, 1909-10**

TO THE MEMBERS OF THE LEAGUE OF CALIFORNIA MUNICIPALITIES.  
GENTLEMEN:—

For the twelfth time it is my pleasure to submit an annual report concerning the operations of the League of California Municipalities. I trust that it will be considered a report of progress. In these times when progressiveness seems to be in the minds of the mass of our citizens, and made the battle cry leading to political victories, it is eminently proper that Municipalities should evince a similar spirit and keep in touch with the advanced ideas that promise much for the future. And with this idea in mind, I would suggest for this League to formulate a pro-

gram to be followed by the cities of the state, which, to a certain extent may serve as a guide in reaching a higher plane of usefulness. In this program should be included requests to the legislature to enact such laws as will promote the development of our respective committees.

It has been heralded throughout the state that the Legislature soon to convene, is to be the first progressive one in the state and its numbers have been pledged to all measures that will promote the public good.

It is to be hoped that the prophecy will find fulfillment and should it be so, we would be ready to seek its co-operation in conserving the rights, privileges and powers of the Municipalities as against those of private interests.

With this thought, the program that has been so arranged that discussion may be had upon measures that may require legislation to make them affective and a discussion of the so-called commission form of government, may eventuate in a request of the legislatures to apply it to the government of the cities incorporated under the general laws. A discussion of the relation between the Municipalities and the public service corporations may lead to a request to the legislature to enact measures that will make those relations more amicable and at the same time protect the public from injustice. Other subjects will doubtless be presented here that will lead to demands for progressive legislation.

The work of the Secretary's office during the past year has been much the same as in previous years.

Very fortunately, the services of Mr. W. J. Locke as assistant secretary, have been continued during the year and he has displayed an unusual aptitude for the work in hand. He has devoted himself to the building up of the League. New members to the association to the number of sixteen have been secured and there are promises of more in the near future. There have been no withdrawals from membership. The new members are: Point Arena, Fairfield, Tehachapi, Sierra Madre, Colton, Lodi, Oroville, Corina, Selma, Escondido, Newman, Coalinga, Lindsay, Palo Alto and Corona. Bakersfield and Antioch have rejoined after an absence of several years.

Early in the year the League took up the matter of the defense of the cities and sanitary districts in the suits commenced and threatened by the Cameron Septic Tank Company, for an alleged infringement of their patents covering the construction of septic tanks.

Contributions to a common defense fund were solicited and generously responded to. An account of this litigation has been published in the magazine and an account of the fund has likewise been given. A further report on this subject will be given by our attorneys during this meeting.

It has been the endeavor of this office to build up this magazine during the year that it may be of greater interest and use to our officials. In this we have been quite successful and it is now about self supporting. For good of the League we trust that the officials will, so far as the law will permit and consistent with the public good, favor these advertisers in the magazine. It is by their financial aid that makes its publication is made possible and we should reciprocate whenever it is within our power.

The information bureau of the League has received its usual number of inquiries during the year. In this connection, I wish to say for Mr. Locke, who has conducted most of the correspondence of this department, that his work appears to be very satisfactory. Promptness in replying to inquiries has been a prominent characteristic in his work. Moreover, the information furnished has been generally satisfactory. Gradually the League has been building up a statistical

department, which cannot fail to be of great benefit to all Municipalities. With a little larger fund, we could do considerable more in this line, and it is probable that the revenues of the League next year will be somewhat increased. The census will show that many towns have increased in population and this good fortune on their part will have its compensation in being compelled to pay an advanced scale of dues to the League.

We wish to commend the Administration of Mayor Evans, President of the League. He has shown a keen interest in this organization and has promoted its welfare in many respects.

The following is a financial statement covering the past fourteen months, the last report having been rendered in September 1909.

RECEIPTS	
Balance on hand, last report	\$ 26.50
Received for dues	2690.00
	\$2716.50
EXPENDITURES	
Salary of Sec. and Ass't 14 months	\$1750.00
Rent	116.75
Expenses Santa Cruz Convention	131.00
Stationery, stamps, printing, etc	135.94
Balance cash on hand	582.81
	\$2716.50

Thanking the members of the League as officers and as individuals for many courtesies and with best wishes to them in return, this report is respectfully submitted.

(Signed) H. A. MASON, Sec'y  
W. J. LOCKE, Ass't

## AUDITING COMMITTEE'S REPORT

San Diego, Cal., November 16, 1910

HON. S. C. EVANS, President

California League of Municipalities:

The auditing committee appointed to examine the accounts of the Secretary of the League has examined all of the data submitted and has found everything to check with the exception of an error of 2 cents in the footing for July, 1910, whereby the Secretary has failed to credit himself with that amount which was actually paid out.

We find that he has apparently not credited himself with the postage on magazines for July and September, 1910, as he has done for the other months covered by the reports.

We understand that changes in the system of accounting are contemplated and suggest that the business of the League be put on a commission basis.

We suggest that in the future the account books of the League including all books, vouchers, paid checks and balanced bank book be brought to the annual meeting for examination and verification by the auditing committee.

W. F. HYDE,  
CHARLES N. KIRKBRIDE,  
J. H. STRAIT.



## RESOLUTIONS ADOPTED AT THE SAN DIEGO CONVENTION

---

### State Highway Commission

In view of the vast amount of money expended in the state in experiments in street and highway constructions we recommend that a State Highway Commission be appointed whose duty shall be to make investigations, collect data and compile statistics to the end that this information may be of use to cities, towns and counties; and have the care and authority over public ways as to their construction, maintenance and repair. Also, in conjunction with the engineering department, to advise in relation to the expenditure of money and the construction of any roads under state management and authority.

### State Highway Bond Money

Resolved, that we favor the employment by the state of experts to investigate the matter of highway construction, and are not in favor of the expenditure of any of the proceeds of the sale of the State Highway Bonds recently authorized for construction of state highways until after a full investigation by experts and the determination by them of the best type of highway construction.

### Automobile Tax

Resolved that the Legislation Committee be instructed to prepare an amendment to the "Automobile Law" that will permit the imposition of a reasonable license tax on automobiles, the proceeds thereof to be used for the maintenance of public highways.

### Public Utilities Commission

Resolved, that the League of California Municipalities, assembled at its Thirteenth Annual Convention held at San Diego, November 15 to 19, 1910, where 65 municipalities were represented by 195 delegates, hereby expresses its approbation of a measure to provide for a State Public Utilities Commission to be endowed with power—

1. To compel publicity of the accounts and operations of Public Service Corporations.
2. To regulate the issuance and sale of corporate stocks, bonds and certificates of indebtedness.
3. To authorize and require capital expenditures.
4. To require adequate service in every respect of such corporations to the communities which they serve.
5. To determine valuation of the property of such corporations.
6. To advise and assist municipalities and other public corporations when requested by them in determining the rates to be fixed for the service rendered by such public service corporations.
7. In cases where the power to fix rates is not vested in any municipality or other public corporation to fix such rates and prescribe the quality of the service.

Resolved that the legislature be and it is hereby memorialized to enact the necessary laws to carry out the purpose herein set forth.

### **California-Pacific International Exposition**

Resolved, that we favor San Francisco as being the most suitable place for an International Exposition to be held in 1915 to commemorate the opening of the Panama Canal and we pledge our utmost endeavors to securing the success of such exposition.

### **California-Panama Exposition**

Resolved, that this organization will co-operate with San Diego in insuring the success of its proposed California-Panama Exposition, realizing that such exposition will in no way conflict with that in San Francisco and that such an enterprise will promote the well-being of the state.

### **Our Municipal Exposition**

Resolved, that we appreciate the efforts of the dealers in municipal supplies in presenting us with an admirable exhibition of their wares; that we recognize this exhibit as a valuable auxiliary to our annual conventions and trust that it may be made a permanent feature thereof; that we will on all occasions recognize quality of material and workmanship as determining factors in awarding contracts for supplies and for public work.

### **Chicago Municipal Exposition**

Resolved, that this League favors having proper representation at the Municipal Exposition to be held in Chicago in October, 1911, and that the municipalities represented are hereby pledged to make a proper exhibit of their energy and progress: that we recognize the occasion as an excellent one at which to advertise our institutions and to attract the attention of the people of the east to our municipal advancement.

### **Thanks to Mayor Evans**

Resolved, that the thanks be given to our most worthy president, Mayor Evans of Riverside, for his faithful services during the past year, and for the courtesy and ability displayed as the presiding officer of this convention, and that he carry away with him our best wishes for his future happiness.

### **Thanking People of San Diego**

Resolved, that the thanks of this convention be tendered to our hosts on this occasion, the officials of the city of San Diego, its civic associations, newspapers, the San Diego Electric Railway Company, the Coronado Ferry Co., the Electric Light Company, and citizens for making this visit to their beautiful and enterprising city so thoroughly enjoyable and an event to be ever treasured in our memories. We wish them enduring prosperity and neverending progress.

### **Publication of Proceedings**

Whereas, the League of California Municipalities, now in session, is transacting a vast amount of business of vital importance to the cities of the State of California, and

Whereas, the proceedings thereof should be furnished to every city belonging to said League, therefore, be it

Resolved, that the Secretary of said League be requested, and he is hereby instructed to cause the full proceedings of the present session and Public Health Association to be printed in pamphlet form at the earliest possible time and distributed to the cities composing said League, and sample copies be sent to the cities not members.

## RELATIONS WITH THE PUBLIC\*

Of the attempts to bring into accord the real and imaginary differences between utility corporations and their patrons, none has been more successful than that undertaken by Mr. S. M. Kennedy, General Agent for the Southern California Edison Company. During the session of the Eighteenth Convention of the Pacific Coast Gas Association held in Los Angeles last September, Mr. Kennedy delivered a remarkable paper entitled, "Relations with the Public". In the brief space which has elapsed since the convention, this paper has become both a classic and a text-book. It is being published in newspapers and magazines from the Pacific to the Atlantic, and many large corporations are reproducing it in pamphlet form for the uplifting of their employees. The publicity which Mr. Kennedy's paper has attained is very much on the lines of Elbert Hubbard's *Message to Garcia* which was distributed by the New York Central Railroad and by the employing public some fifteen years ago. The ingenious frankness with which Mr. Kennedy deals with his topic commends it to the reader no matter what may be his life work or affiliations.

Admitting the differences which exist, Mr. Kennedy says:

"No one can deny that prejudice against corporations exists in the minds of many people throughout the country. Let us try to analyze how much of this prejudice has reasonable cause for existence, and how much of it may be classed as traditional. To a certain extent, the apathy of part of the public is founded on hearsay and not always supported by facts. It has been said "The evil that men do lives after them," and I have in mind the name of one man who put a stigma on public utility corporations which seems to hurt their standing in the public mind as much today as it did a quarter of a century ago, when the crime was committed. He was a gruff man, with a big head, cold looking eyes and a frowning face, devoid of one trace of magnetism. He was a conspicuous figure in the financial world, and the president of a great railroad corporation. I do not recall the circumstances surrounding the unfortunate utterance; I do not know whether or not he had any justification for using the words, but he is credited with having coined the expression "The public be damned." The public loudly resented it then, and the public has since been unmistakably suspicious of corporations, and is ever ready to pounce on corporation words or actions which may have a "Public be damned" look about them. Should the people be inclined to forget the words, there are those who will not let them do so."

"You have no more important duty to your own interests than that of educating the public to a proper appreciation of the existing facts," says Mr. Kennedy, "after you are sure what they ought to be. All publicity of misinformation should be counteracted by even greater publicity of the true conditions. The public talks of your enormous income; tell them about the enormous expenses. Much is said about your tremendous profits; tell them about the great repair and maintenance bills you are called upon to pay; tell them about the depreciation bill which is running up against you day and night; and tell them about the small rate of interest earned on the capital invested."

"Tell the public what you are really doing for them. Show them how constant and ready is your service. The consumer turns a valve in any part of his house; instantly the service is at his command. Does the grocer, butcher or baker serve them as quickly?"



Mr. Kennedy advises employers to avoid men of rough surfaces, and in this connection says:

"Each man representing a point of contract, who meets the public personally, should be selected and fitted for his position. At your plant you use great care in the construction of your machinery. You would not think of putting a half-inch rivet into a one inch hole and expect it to work satisfactorily. You would not permit a rough surface to remain on a valve which you must handle constantly. Well, keep your eye on your office and use the same amount of sense. Don't expect an inexperienced boy to handle your complaints satisfactorily. Get more mature men. They will handle the public better and the public likes to talk to them. Look out for the men with the rough surfaces; the men who prefer to argue and not explain. They may win many arguments, but they lose many friends for your company."

Some very apt and logical advice is given by Mr. Kennedy in reference to business transacted over the telephone, also in regard to the art of writing letters which make friends.

"The real courtesy which we are talking about," says Mr. Kennedy, "does not mean palaver, bowing and scraping, but common, everyday politeness. It does not mean toadying to customers, whether they are big or little, but the giving to all a cheerful attention. It is the kind that gives and wins a smile; the kind that does not forget to say "thank you" when the opportunity occurs. This sort of courtesy is a fine art, and is as necessary to the healthy growth of your business as is the sunshine to the flowers."

Mr. Kennedy concludes his paper with some earnest admonitions concerning "honesty for honesty's sake" and he coins this axiom "the public-be-pleased" policy. He says in part:

"Our customers should realize that, after all, a corporation is only an aggregation of individuals. I recognize that some things must be done for politic reasons, but why should a corporation eternally require to study policy? Why not the man-to-man idea, instead of the corporation and the public attitude? Why not have customers go to your office to do business feeling that they like to do business with you? Why not cut out the word policy in the sense it is usually accepted by corporations, and let your patrons understand that the only policy you know in connection with your company is—the public be pleased. That policy does not mean giving way to all demands. It does not necessitate loss of dignity, self-respect, or income, but, on the contrary, when faithfully carried out, it represents the easy, safe and profitable way of doing business. With a "public be pleased" policy, your difficulties will decrease in proportion with the length of time it is in effect, and the subject of relations with the public will gradually be changed from a vexed problem to a condition closely resembling that of pleasure."

\*This article was sent in with the request that it be published on account of its bearing on a matter of vital concern to municipalities.

## SECURE AN HONEST VOTE. HOW?

This was the caption of a booklet that was freely circulated among the League delegates at the San Diego, California, Convention. This booklet is issued by the Triumph Voting Machine Company of No. 60 Wall street, New York. This company manufactures the Triumph Voting Machine, their factory

being at Pittsfield, Mass., and they demonstrated one of their most improved machines as a part of the municipal exhibit. This exhibit attracted unusual interest as it had to do with a subject in which every member of the League is interested, that of securing an honest vote accurately counted and securing said count against any fraudulent manipulation after the polls are closed.

These features are the principal reasons for using voting machines. An honest vote is secured as the voter is free to vote as he pleases. He is compelled to vote in absolute secrecy, and if votes are paid for there is no way of knowing that they are delivered. This evil is consequently greatly lessened and further the voter cannot be intimidated by his employer as there is no way to distinguish any individual vote cast. When the vote is once recorded there is no way to change the results, the vote is counted or recorded by means of exact mechanical counters, one for each candidate. These counters are positively actuated and cannot fail to count every vote as cast by the voter.

The use of machines does away with any possibilities of a recount. There is no chance of changing the results, a majority of one is as effective as a majority of one thousand. The total vote for each candidate is read directly from the registers there being no clerical work to do except to write down the vote as it is read off the machine.

The operation of the Triumph Voting Machine is extremely simple. The voter approaches the machine from the side opposite the one where the ballot is displayed and as he passes the end of the machine he operates a lever from the vertical to a horizontal position, this unlocks the machine ready for "voting". A split, scratch or straight ticket is easily voted by operating levers corresponding to the candidates to be voted. There is one lever to operate for voting each party vote, and small levers for each individual candidate that are operated after the straight vote is indicated to split or scratch the ticket. These levers, when voted, point directly to the name of the candidate being voted for in such a way as to leave no doubt in the mind of the voter how his vote is recorded. When he has his ballot arranged he passes out from the machine the way he entered raising the lever at the end of the machine to the position he formed it when he entered to vote. The raising of this lever counts his vote adding one to the number on each register or counter corresponding to the candidate being voted.

The machine is provided with all the features necessary to care for the restricted votes both on the main ballot and on the proposition to be voted on. It has a primary attachment enabling the machine to be used at primary elections. In fact the machine was claimed to be complete in every way and its demonstration seemed to justify this claim. It was frequently remarked by those having had previous experience that this machine appeared to be most complete and simple in its operation. The machine exhibited was one of the largest ever made, it having nine party lines and capacity for voting seventy candidates on each party line. This is nearly twice the size used in most cities such a size as exhibited is required for the city of Chicago and the ballot displayed was a Chicago ballot. A very interesting feature of which was the cumulative vote which is a feature of the Illinois state laws.

Voting machines are used by nearly a million votes at every election, and the time cannot be very far in the future when all voters will be recorded mechanically as this is the modern way of doing things. The using of the proper ballot and counting the vote is both cumbersome and inaccurate and results many times in defeating the will of the people.

The privilege of the ballot should be rightly appreciated and anything that tends to keep this privilege inviolate should be welcome by all.

## THE EXHIBIT OF PARROTT & CO.

---

Parrott & Co., the exclusive Pacific Coast Agents for the Concrete Appliances Co's., "Gravity System" of distributing concrete; also Coast agents for the Rulofson Underwriters Approved Fire Proof Metal Windows and Doors, furnished a most interesting booth illustrating these two subjects.

In the booth were enlarged photographs showing the addition to the Sweet-water Dam now being constructed in San Diego County.

Illustrated books were distributed, showing the many buildings on which "Gravity System" is now used; also giving vital information on this revolutionary method of concrete distribution; with cost of equipment, etc.

With the "Gravity System" of concrete distribution in operation, invitations were issued to the visiting engineers at the convention to inspect the dam site; and the trip was made by most of the engineers interested in water supply problems.

The booth also contained an exhibit of full sized samples of "*Rulofson*" windows and doors of the approved Underwriter's type, which were very useful in illustrating the lectures delivered by Mr. Robertson, chief engineer of the Underwriters of the Pacific Coast on the subject of fire proofing of openings in city buildings within fire limits.

Parrott & Co., also assisted in the exhibition of Genasco Roofing, and water-proofing papers, for which they are the selling agents on the Coast for the Barber Asphalt Paving Co. The booth was presided over by N. W. Howard, representing the construction department of Southern California for Parrott & Co.



## QUESTIONS AND ANSWERS

---

NOVEMBER 22, 1910.

Q.—Is it necessary for the town officers to give bonds in a fidelity company or can they get private individuals that are worth the amount of the bond to go on their bonds; also is it in the power of the trustees to pay an officer's bond if they see fit.

Ans.—Replying to your inquiry of November 22, will say that town officers may give a bond with private individuals as sureties if they choose. There is nothing to prevent the trustees paying the expense of an officer's bond if they wish to; it is the practice in many places.

OCTOBER 28, 1910.

Q.—Is it possible for you to obtain for and send to me a copy of the Ordinance of the City of Berkeley prohibiting the use of slot machines, or the ordinance of any city which has proved not only stringent but effective in the prohibition of those contrivances?

Thanking you in advance for your courtesy, I am

Ans.— We send you enclosed herewith copies of such ordinances now in force in Los Angeles and San Francisco.



NOVEMBER 9, 1910

Q.—A member of our Board of Trustees has recently been appointed Justice of the Peace. Is there any law to prevent him from holding both offices?

ANS.—There is nothing to prevent him from holding both offices, but he would probably be disqualified from setting on a case involving the infraction of a municipal ordinance which was passed while he was a trustee.

Q.—Mr. Locke was telling me when I was in San Diego that it was possible to get some information as to the Cameron Septic Tank. Now I would like to know if I wrote to Washington what should I ask for and what would be the amount of money to send and where would I get the rest of information in order to get a complete knowledge of the whole business.

I went up to Whittier and saw the new tank they have put in there; it was doing good work.

Hoping you will give me the information I am asking I am very truly yours.

ANS.—By way of reply to yours of November 25, would advise you to write to the Patent Office at Washington, D. C., enclosing 25 cents and ask them to send the drawings and specifications for *Patent No. 614523, issued October 3, 1899 to Donald Cameron* and others.

The Circuit Court of Appeals in its decision rendered January 6, 1908, said that the Cameron Septic Tank built at Saratoga Springs worked perfectly. See *PACIFIC MUNICIPALITIES*, May 1910, pages 118. You would therefore make no mistake in insisting that your engineer follow those specifications closely.



## PATRONIZE OUR ADVERTISERS

---

Members of the League can materially assist the upbuilding of our organ, *Pacific Municipalities*, by favoring our Advertisers wherever possible. Our advertisers are always pleased to answer inquiries.

Mention *Pacific Municipalities* when writing to them.

**What the Cities Are Doing**

**Oakland** is putting down a lot of oil macadam pavement.

**Pasadena** is advertising for wattmeters for its municipal lighting plant.

**Monterey** is about to start construction of its new high school building.

**Santa Paula** has adopted plans and specifications for its new sewer system.

**Ontario** will receive bids for its \$175,000 water bonds on December 5th.

**St. Helena** will receive bids on December 6, for building a large storm sewer.

**San Anselmo** has an appropriation of \$5000 for the construction of a town hall.

**Santa Cruz** is about to proceed with the construction of a garbage incinerator.

**Porterville** starts proceedings for a large bond issue to extend the city water system.

**Palo Alto** has decided to provide an office and laboratory for the use of its Health Officer.

**Grass Valley** is extending its sewer system and macadamizing streets in the residence section.

**Monterey** will vote on the question of ratification of the proposed new charter, on Dec. 12th, 1910.

**Vallejo** has sold its \$90,000 bonds recently voted for improving its water system, for par and a premium of \$1908.00.

**Redding** will receive bids on Dec. 5 for the purchase of an Automobile Combination Hose Wagon and Chemical Engine.

**Crescent City** is taking measures to provide better fire protection, by the purchase of more hose and the organization of two fire companies.

**Willows** will vote on December 12th on a proposition to bond the city for \$50,000, including \$25,000 for a City Hall and \$10,000 for fire engines.

**Stockton** citizens are endeavoring to raise \$25,000 to assist Sacramento in bringing about the widening and deepening of the channel between Rio Vista and Collinsville.

**Imperial.** Judge Welborn has sustained the demurrer of the city in the case of the Imperial Light, Water and Power Company against the city and dismissed the bill of complaints.

There were two questions at issue: Whether the building of a municipal water system constituted confiscation of the private corporation's system and whether the reservation of exclusive franchises in the city is valid.

**Fullerton** recently lost its fine Union High School by fire. A defect in the furnace system of heating is thought to be responsible. The loss is estimated to be between \$50,000 and \$60,000.



**The Man Who Wins**

The man who wins is the man who does,  
Who makes things hustle and hum and  
buzz;

The man who works and the man who  
acts,

Who builds on a basis of solid facts;  
Who doesn't sit down to mope and  
dream,

But humps ahead with the force of  
steam;

Who hasn't the time to fuss and fret,  
But stakes his money and wins the bet.

The man who wins is the man who  
wears

A smile to cover his burden of cares;  
Who knows that the sun will shine  
again,

That the clouds will pass and we need  
the rain;

Who buckles down to a pile of work  
And never gives up and will not shirk  
Till the task is done and the toil made  
sweet,

While the temples throb with the red  
blood's heat.

The man who wins is the man who  
climbs

The ladder of life to the joyous chimes  
Of bells of labor and songs of cheer;  
He isn't afraid of the critic's sneer,  
For he faces the glow of the midday  
sun

And works in the light till his task is  
done--

And makes things hustle and hum and  
buzz;

The man who wins is the man who  
does.

—Folger McKinsey, in Baltimore Sun.

## LIST OF RESPONSIBLE FIRMS TO BE CALLED ON TO BID FOR PUBLIC WORK OR SUPPLIES

### WRITE FOR CATALOGS

This list is arranged as a guide for the accommodation of city officials where advertising for bids is not necessary.

- Accountant**  
William Dolge, C. P. A., 255 California St., S. F.
- Architects**  
W. H. Weeks, 251 Kearney St., S. F.
- Asphalt Machinery**  
A. L. Young M'chy Co. 26-28 Fremont St., S. F.
- Arch. Terra Cotta**  
Gladding, McBean & Co., Crocker Bldg, S. F.
- Automobile Public Service Wagons**  
Consolidated Motor Car Co., Cor. Van Ness and McAllister Sts., S. F.  
The Thomas B. Jeffery Co., 117-125 Valencia St., S. F.
- Bitulithic Pavement**  
Warren Brothers Company, Los Angeles, Cal.
- Blue Prints**  
So. Cal. Blue Print & Supply Co., 800 L. A. Trust Bldg., Los Angeles.
- Bridge Builders**  
Keatinge-Bradford Co., 615 Humboldt Bk Bdg.  
E. T. Thurston, Jr., Wells Fargo Bldg., S. F.
- Concrete Construction**  
Keatinge-Bradford Co., 615 Humboldt Bk Bdg.  
Hazelwood, Jones, Doane & Hanscom, 675 Monadnock Building, S. F.
- Contractors and Builders**  
Finch Jail Building and Metal Co., 16 California St., S. F.
- Constructing Engineers**  
Fred'k C. Roberts & Co., 221 Sheldon Building, S. F.  
W. N. Concannon Co., 433-437 Monadnock Building, S. F.
- Consulting Engineers**  
Spaulding, Sloan & Robson, 802 Union Trust Building, San Francisco.  
E. T. Thurston, Jr., Wells Fargo Bldg., S. F.
- Drinking Fountains**  
Haines, Jones & Cadbury Co., 851-859 Folsom St., S. F.
- Dump Carts and Wagons**  
A. L. Young M'chy Co., 26-28 Fremont St., S. F.
- Electrical Plants & Machinery**  
A. L. Young M'chy Co., Fremont St., S. F.  
Chas. L. Kiewert Co., 195 Fremont St., S. F.
- Engravers and Bond Printers**  
Commercial Art Co., 53 Third St., S. F.  
Schmidt Lithograph Company, Second & Bryant Sts., S. F.  
Sierra Art Engraving Co., Front & Commercial Sts., S. F.
- Fire Alarm and Police Tel. Systems**  
Gamewell Fire Alarm Tel. Co., Market and Battery Sts., S. F.
- Fire Dept. Equipment**  
Cal. Fire Apparatus Co., Jessie and New Anthony, S. F.  
R. S. Chapman, 400 Golden Gate Ave., S. F.
- Fire Engines**  
Gorham Rubber Co., 50-56 Fremont St., S. F.
- Fire Extinguishers**  
Goodyear Rubber Co., 589 Market St., S. F.
- Fire Hose**  
Gorham Rubber Co., 50-56 Fremont St., S. F.  
Eureka Fire Hose M'fg Co., 610 Postal Tel. Building, S. F.  
New York Belting & Packing Co., 129-131 First St., S. F.
- Gasoline Engines**  
Doak Gas Engine Co., 7-9 First St., S. F.
- Lithographers**  
Schmidt Lithograph Company, Second & Bryant Sts., S. F.
- Metal Furniture**  
Finch Jail Building and Metal Co., 16 California St., S. F.  
Art Metal Construction Co., Flood Bldg., S. F. Story Building, Los Angeles.
- Municipal Accountant**  
William Dolge, C. P. A., 255 California St., S. F.
- Municipal Printers**  
A. Carlisle & Co., 251-253 Bush St., S. F.
- Municipal Pumping and Water Service**  
Fredk. C. Roberts & Co., 461 Market St., S. F.
- Pavement Materials**  
Warren Brothers Company, Los Angeles, Cal.
- Playground Apparatus**  
A. L. Young Machinery Co., S. F.
- Reinforced Oil Concrete Streets**  
E. M. Chadbourne Co., 800 Postal Tel. Building, S. F.
- Riggers**  
C. A. Blume Con. Co., 185 Stevenson St., S. F.
- Road Machinery**  
J. I. Case Threshing Mch. Co., 616 Myrtle St., Oakland, Cal.  
Henshaw, Bulkeley & Co., Fremont St., S. F.  
A. L. Young M'chy Co., Fremont St., S. F.  
Petrolithic Pav. Co., 209 E. 7th St. Los Angeles
- Safes**  
Cary Safe Co., 669-671 Mission St., S. F.  
Parcells Safe Co., 577 Market St., S. F.  
Victor Safe & Lock Co., 1292-4 Market St. S. F.
- Scrapers**  
A. L. Young M'chy Co., Fremont St., S. F.  
Petrolithic Pav. Co., 209 E. 7th St., Los Angeles.
- Sewer Pipe and Terra Cotta**  
Gladding, McBean & Co., Crocker B'ldg, S. F.  
Steiger Terra Cotta Co., Mills B'ldg., S. F.
- Street Signs**  
A. L. Young Mch. Co., S. F.
- Street Sweepers**  
A. L. Young M'chy Co., Fremont St., S. F.
- Structural Steel Erectors**  
C. A. Blume Construction Co., 185 Stevenson St., S. F.
- Vaults**  
Cary Safe Co., 669-671 Mission St., S. F.  
Parcells Safe Co., 577 Market St., S. F.  
Victor Safe & Lock Co., 1292-4 Market St., S. F.
- Water Supply**  
Doak Gas Engine Co., 7 and 9 First St., S. F.



**SEWER DISTRICT BONDS.**

Cities and towns are advised against attempting the use of the act passed by the last legislature "to provide for separate sewer districts within municipalities." It is known as Act 3597 and was devised to enable the bonding of portions of a town for sewer purposes. It does not clearly indicate in the act whether the bond is to be a municipal bond or district bond; moreover, it is undoubtedly in conflict with Sec. 18, Art. XI of the Constitution, which requires a two-thirds vote to incur any indebtedness.



San Bernardino spent \$248,645.99 last year for street work under the Vrooman Act in addition to \$43,000 collected in taxes. A year ago the city had one mile of street paving; today there are ten miles. The statement published last month was not correct.



**"HYGENIC" DRINKING FOUNTAIN**  
 For Schools, Railway Stations, etc. Prevents contagion and provides each user with an ample supply of fresh water.  
 Illustrated circular sent on request.  
 The newest things in plumbing fixtures for Schools, Factories and Office Buildings are on display in our Show Rooms.  
 851-859 Folsom Street, San Francisco, Cal.  
 Phones, Sutter 1130; Home J-2110  
**Haines, Jones & Cadbury Co.**  
 Makers of Plumbing Supplies  
 1130-1144 Ridge Avenue, Philadelphia  
 Branches—Savannah and San Francisco

F. W. Haselwood, Assoc. M. Am. Soc. C. E.      Sidney Jones      E. W. Doane      W. A. Hanscom

**Haselwood, Jones, Doane & Hanscom**  
*Civil, Hydraulic and Sanitary Engineers*  
**Sewers, Waterworks, Light Plants, Street Work and Bridges**

Phone Sutter 1337      675-677 Monadnock Building      SAN FRANCISCO, CAL.

**E. T. THURSTON, Jr.**

Assoc. M. Am. Soc. C. E.

**Consulting Engineer**

713 Mechanics' Institute

Phones Sutter 1683 and C 2895      SAN FRANCISCO

**Specialties**

Design and Supervision of Buildings, Bridges, Railways, Water Works and Municipal Work

**Concrete Bridges**

Exclusive rights under patents of National Bridge Company, the largest in the world.

Estimates furnished free of charge.

**C. A. BLUME CONSTRUCTION CO.**

Members of Builders Exchange

**Structural Steel Erectors**  
**Riggers**

Phone Douglas 324  
 185 STEVENSON STREET

SAN FRANCISCO

**W. N. CONCANON CO.**

**Constructing Engineers**

Foundations, Reinforced Concrete, Steel and Concrete Buildings and Bridges  
 General Engineering Work. Special Attention Given to Public Work

433-437 Monadnock Bldg.      Phone Kearny 2884.      681 Market St.      SAN FRANCISCO, CAL.



When a man feels the necessity of being in two places at the same time he goes to the nearest telephone and sends his voice. It is not exactly the same thing, but when a man talks hundreds of miles in opposite directions from the same Bell Telephone, it is about as good. In the daily use of the telephone a man travels all over town by wire in a few minutes. It is just as easy to travel all over the state and other states by means of the universal Long Distance Service of the Bell System.



**The Pacific Telephone & Tel. Co.**

*Every Bell Telephone is the Center of the System*



## Decarie Patent Garbage and Refuse Incinerator

MANUFACTURED BY

### DECARIE INCINERATOR COMPANY

The DECARIE PATENT INCINERATOR is a STEAM GENERATOR and consists of a GARBAGE, RUBBISH, REFUSE and DEAD ANIMAL, destroying MAIN INCINERATING furnace, with TWO sets of GRATES, UPPER PIPE GRATES and LOWER CAST IRON SHAKER GRATES, an EXTENSION FURNACE and a GAS CONSUMING FURNACE.

Wet material is dumped directly into the Decarie Incinerator without smothering the fire. This cannot be done with any other system.

Any ordinary mechanic can make repairs.  
 Every drop of liquid is evaporated.  
 Every atom of garbage is burned.  
 Every particle of odor is destroyed.  
 Every function is perfectly sanitary.

The cost of Incineration by the Decarie system is 50 to 75% less than by any other method. This is demonstrated absolutely by plants now in operation throught the state. When desired power can be utilized from the steam developed during the process of incineration.

WRITE FOR DETAILED INFORMATION TO

**DECARIE INCINERATOR COMPANY, - Hopkins, Minn.**

**WILLIAM DOLGE**

*Certified Public Accountant --:-- Municipal Accountant*

TELEPHONE DOUGLAS 5173

255 California Street

San Francisco, Cal.

**WM. H. WEEKS, Architect**

PUBLIC BUILDINGS A SPECIALTY

251 Kearney Street

San Francisco

**SPALDING, SLOAN & ROBSON**  
CONSULTING ENGINEERS

Waterworks, Sewer Systems, Paving, Lighting Plants

Telephone Kearney 4646

802 Union Trust Building, SAN FRANCISCO

Chas. P. Bradford, President

M. Keatinge, Vice-Pres. and Supt.

Howard J. Van Kirk, Secretary

**KEATINGE-BRADFORD COMPANY**

Concrete Contractors and General Contractors

Telephone, Kearny 2921

Room 615 Humboldt Bank Building

SAN FRANCISCO

**GORHAM RUBBER CO.**

RUBBER GOODS OF EVERY DESCRIPTION

Fire Hose, Chemical Engines, Hose Carts, Packing

**50-56 Fremont St., San Francisco**

W. J. LOCKE

H. A. MASON

**Mason & Locke**

ATTORNEYS AND COUNSELORS AT LAW

*Bond proceedings conducted---validity and sale guaranteed*

Ninth Floor Pacific Building

SAN FRANCISCO



The  
Bitulithic  
Pavement  
For Streets  
and Roads



1902	1 Mile	7 Cities
1903	22 Miles	33 "
1904	52 "	40 "
1905	59 "	45 "
1906	59 "	42 "
1907	85 "	57 "
1908	109 "	66 "
1909	95 "	62 "
	118 "	74 "
	679 "	216 "

**TOTAL MILES (30 Ft. Road)**

Combines the inherent stability of the mineral aggregate with the cementing qualities of the asphaltic oil, or other bituminous cement, and produces a smooth, dustless, waterproof pavement, suitable for automobile traffic and driving--prevents skidding and affords a good foothold for horses--is COVERED BY PATENTS, the VALIDITY of which has been SUSTAINED BY THE SUPREME COURT OF THE UNITED STATES.

Send for circulars showing where used and methods of construction.

**WARREN BROTHERS COMPANY**

Portland, Ore.

Boston, Mass.

Los Angeles, Cal.

616 Laughlin Bldg.

REGISTERED TRADE MARKS

"Bitulithic" "Warrenite" "Puritan" "Bitrock" "Bituminous Macadam" "Bi ustone"

**MAPS**  
**BONDS**  
**STATIONERY**  
**BOOKLETS**  
**POSTERS**  
**LABELS**  
**CARTONS**  
**ETC.**

**SCHMIDT LITHOGRAPH COMPANY**

MAIN OFFICE  
SAN FRANCISCO.

PORTLAND      LOS ANGELES

**FINCH JAIL BUILDING AND METAL CO.**



Manufacturers and Builders of

**PRISON CELLS AND ALL APPURTENANCES.**

Dealers in Metal Furniture and Fixtures

Office No. 16 California St.

Telephone Kearney 935

# SPECIAL BARGAINS IN THE BEST MAGAZINES

1. Review of Reviews - - \$3.00 } <b>All For</b>	2. Review of Reviews - - \$3.00 } <b>All For</b>
American Magazine - - 1.50 } <b>\$3.25</b>	Woman's Home Companion 1.50 } <b>\$3.50</b>
Sunset Magazine - - 1.50 }	Sunset Magazine - - 1.50 }
3. American Magazine - - \$1.50 } <b>Both For</b>	4. Woman's Home Companion \$1.50 } <b>Both For</b>
Sunset Magazine - - 1.50 } <b>\$2.00</b>	Sunset Magazine - - 1.50 } <b>\$2.25</b>
5. American Magazine - - \$1.50 } <b>All For</b>	6. Technical World - - (or World Today) 1.50 } <b>Both For</b>
Woman's Home Companion 1.50 } <b>\$2.75</b>	Sunset Magazine - - 1.50 } <b>\$2.35</b>
Sunset Magazine - - 1.50 }	8. Van Norden's - - 1.50 } <b>Both For</b>
7. Forest and Stream - - \$3.00 } <b>Both For</b>	Sunset Magazine - - 1.50 } <b>\$2.00</b>
Sunset Magazine - - 1.50 } <b>\$3.00</b>	10. American Magazine - - \$1.50 } <b>All For</b>
9. Forest and Stream - - \$3.00 } <b>All For</b>	Technical World - - 1.50 } <b>\$2.75</b>
Womans Home Companion 1.50 } <b>\$3.50</b>	Sunset Magazine - - 1.50 }
Sunset Magazine - - 1.50 }	12. McClure Magazine - - \$1.50 } <b>Both For</b>
11. Review of Reviews - - \$3.00 } <b>All For</b>	Sunset Magazine - - 1.50 } <b>\$2.35</b>
Van Norden's Magazine 1.50 } <b>\$3.10</b>	14. Review of Reviews - - \$3.00 } <b>At Half Price</b>
Sunset Magazine - - 1.50 }	American Magazine - - 1.50 } <b>All For</b>
13. Scientific American - - \$3.00 } <b>Both For</b>	Woman's Home Companion 1.50 } <b>All For</b>
(New subscriptions only)	Technical World - - 1.50 } <b>For</b>
Sunset Magazine - - 1.50 } <b>\$3.00</b>	Van Norden's Magazine 1.50 } <b>\$5.25</b>
	Sunset Magazine - - 1.50 }

## *Sunset Magazine, \$1.50 the Year*

CLUBS may be split to go to different addresses.

FREE with each order, two beautiful four color pictures of Yosemite Valley, ("El Capitan" and "Vernal Falls") handsomely mounted. These pictures will be sent flat, not rolled.

POSTAGE to Canada is 50 cents extra on each magazine; to foreign countries is \$1.00 extra.

### SUNSET MAGAZINE FOR 1910 INCLUDES

- (1) A California novel "The Rules of the Game" by Stewart Edward White—to be run as a serial.
- (2) Mexico Today—a series of articles of great interest, by one high in authority in our sister republic.
- (3) Alaska and the Alaskans, by Governor Walter E. Clark.
- (4) The best fiction by such authors as Jack London, Billie Glynn, Eleanor Gates, Dave Coolidge, James Hamilton Osborne, etc.

And many other special features.

ADDRESS

## SUNSET MAGAZINE

313 Battery Street

San Francisco

# MUNICIPAL AND CONTRACTORS' MACHINERY

...FOR...

## GOOD ROADS AND STREETS

Street Signs  
National Road Machines  
Fort Wayne Road Machines  
Indiana Road Machines  
National Elevating Graders  
Elevators—Portable Bunkers  
Shares or Cutting Edges for all types of Road Machines  
Rock Crushers, Jaw and Gyrotory Type, mounted and unmounted  
Screens  
Steam Road Rollers  
Horse Rollers  
Scarifiers  
Harrows for oiled roads  
Wheeled and Drag Scrapers  
Fresno Scrapers  
Reversible Road Plows  
Street Sprinklers  
Sprinkling Attachments  
Street Sweepers  
Fibre for Street Sweepers  
Patent Dump Wagons  
Asphalt Machinery  
Kettles—Hand Rollers—Tampers  
Concrete Mixers  
Hoisting Engines  
Playground Apparatus  
Culvert Pipe

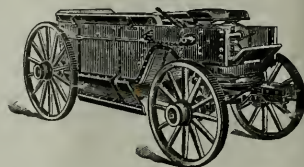
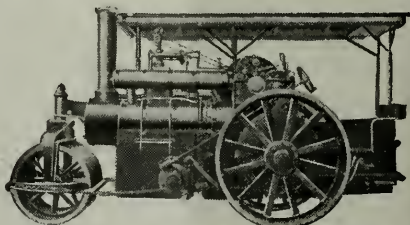
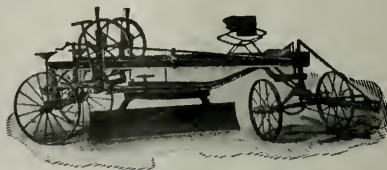

Write us for Catalogues and Estimates

**A. L. Young Machinery Co.**

26-28 Fremont Street

San Francisco

California



DECEMBER 31, 1910

20 Cents

# PACIFIC MUNICIPALITIES

## THE CITY BEAUTIFUL



**PUBLIC  
SAFETY  
HEALTH  
CONVENIENCE**

**PUBLIC  
UTILITIES  
EDUCATION  
RECREATION**

PUBLISHED MONTHLY

SIERRA'S F

## WE WANT YOU TO KNOW

Thanksgiving Day automobile races over the Santa Monica course show this to be the fastest motor road in the country. The Lozier car made 151½ miles at the rate of 73.25 miles per hour, and 202 miles at 71.42 miles per hour. This course is almost entirely a **dirt Petrolithic** road at least five years old, and was not built for a race course. We can build better roads with the Petrolithic Rolling Tamper now than we built five years ago. We want you to know details of Petrolithic Macadam construction.

## PETROLITHIC PAVEMENT CO.

336 Pacific Electric Bldg., Los Angeles, Cal.

SILENT

LUXURIOUS

3 MODELS

THE <sup>NEW</sup> Rambler

Touring Cars, Motor Fire Trucks, Chemical, Hose,  
Police Patrol and Ambulances a Specialty.

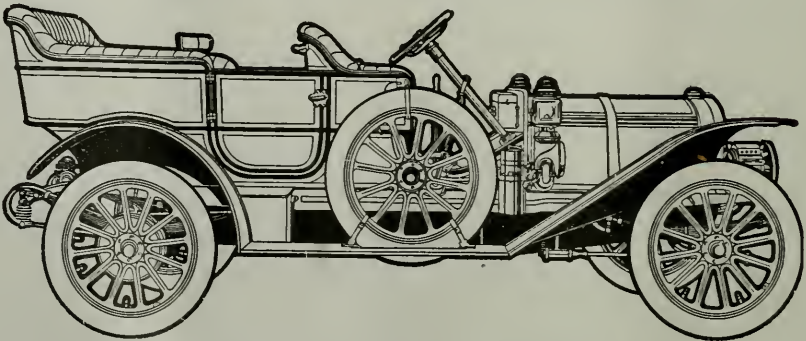

The Thomas B. Jeffery Co.

117-125 Valencia St.

WRITE FOR INFORMATION.

San Francisco

# CASE LINE...

Municipal Hauling Engines  
 Contractors' General Purpose Engines  
 Steam Steered Road Rollers  
 12 @ 16 Bbl. Mounted Fuel and Water  
 Engine Tenders for Engines and  
 Road Rollers  
 Troy Bottom Dump Wagons  
 Road Graders  
 Road Scrapers  
 Road Rooters and Road Drags

Write for our general catalog "M." Address Road Machinery Department.

**J. I. CASE THRESHING MACHINE COMPANY, Inc.** RACINE, WIS.,  
 U. S. A.

BRANCH OFFICE, 616 MYRTLE ST., OAKLAND, CAL.

Insure your Valuable  
 Papers with **Parcells Safe Co.**

AGENTS

"Diebold" Safes and "Allsteel" Metal Furniture

577 MARKET STREET

SAN FRANCISCO

## A. CARLISLE & CO.

**Stationers, Printers and Bookbinders**



We specialize in Bonds, Steel Die, Lithographed or Printed, for  
 Municipalities or Counties, and the Books and Forms  
 required by all Municipal Officers.

251-253 Bush Street

San Francisco, Cal.



# Henshaw, Bulkley & Co.

## ROAD MACHINERY

### A SPECIALTY

19-21 Fremont Street  
San Francisco

262-264 So. Los Angeles St.  
Los Angeles

# The Commercial Art Co.

INCORPORATED

## Designers & Engravers

53 Third Street

San Francisco

TERRA COTTA, PRESSED BRICK, PIPE,  
FIRE PROOFING, ROOFING TILE,  
FLUE LININGS, FIRE TILE,  
LAUNDRY TRAYS,  
ETC.

**GLADDING, McBEAN & CO.**

WORKS  
LINCOLN, CAL.  
--- OFFICE ---  
311-317 CROCKER BLDG., SAN FRANCISCO.

# Steiger Terra Cotta and Pottery Works

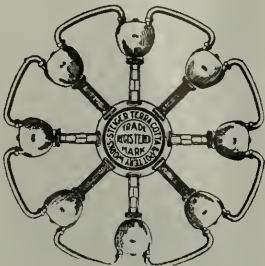

MAIN OFFICE AND YARDS:

City Yard, 18th and Division Streets

Main Office: 729 Mills Building

Phone Douglas 3010

SAN FRANCISCO, CAL.

Factory, South San Francisco  
San Mateo County

NOTE—Every city official in California reads Pacific Municipalities.

# Pacific Municipalities

OFFICIAL ORGAN OF THE LEAGUE OF CALIFORNIA MUNICIPALITIES

Entered at Post Office, Santa Clara, Cal., as Second-Class Matter

---

VOL. XXIII

TWELFTH YEAR

No. 5

---

EDITORS - - - H. A. MASON AND WM. J. LOCKE  
EDITORIAL OFFICE - NINTH FLOOR, PACIFIC BLD'G, SAN FRANCISCO  
PUBLICATION OFFICE, - - - SANTA CLARA, CALIFORNIA

---

## CONTENTS FOR DECEMBER, 1910

---

Proceedings of the Thirteenth Annual Convention of the League of California Municipalities .....	197
Address of Welcome .....	198
Response to Address of Welcome .....	199
The Progress of Commission Government .....	202
Value of Street Trees .....	226
Department of City Attorneys .....	
The Ideal City Charter .....	231
The Evolution of Corrugated Metal Culverts .....	236
Colusa's New Waterworks .....	238
Questions and Answers .....	242
Editorial .....	248
Framing of New Ordinances .....	248
Our New Tax Systems .....	248
Licenses Under Senate Constitutional Amendment No. 1 .....	248
What the Cities Are Doing .....	249

---

Published Monthly. Yearly Subscription, \$2.00 in Advance. Single Copies, 25 Cents

ADVERTISING RATES ON APPLICATION

Address all Communications to "PACIFIC MUNICIPALITIES" Pacific Building  
San Francisco, California

# LEAGUE OF CALIFORNIA MUNICIPALITIES

Organized 1897

## — OFFICERS —

President - - - - (Mayor of Berkeley) - BEVERLY L. HODGHEAD  
 First Vice-President - - (Councilman of San Diego) - A. E. DODSON  
 Second Vice-President - (Mayor of Santa Cruz) - T. W. DRULLARD  
 Secretary - H. A. MASON Ass't Secretary - W.M. J. LOCKE

## STANDING COMMITTEES

EXECUTIVE—Beverly L. Hodghead; H. A. Mason; S. C. Evans, Mayor of Riverside; Percy V. Long, City Attorney San Francisco; W. P. Butcher, City Attorney Santa Barbara.  
 LEGISLATIVE—W. F. Hyde, Palo Alto; J. O. Walsh, San Francisco; J. H. Strait, Redlands; F. H. Allbright, Red Bluff; B. L. Barney, Hanford.  
 JUDICIARY—C. N. Kirkbride, San Mateo; P. G. Sheehy, Watsonville; Stephen G. Long, Long Beach; R. E. Rhodes, Madera; Wm. J. Carr, Pasadena.  
 ENGINEERING—Chris. P. Jensen, Fresno; C. H. Pieper, San Jose; A. P. Noyes, Vallejo; R. C. Tunnelly, Stockton; O. E. Stewart, Anaheim.

Secretary's Office and Headquarters of the League, - Pacific Building, San Francisco

## INFORMATION BUREAU

The League of California Municipalities maintains, in connection with the Secretary's Office an Information Bureau where the officials of the municipalities belonging to the League can secure information on all subjects relating to municipal affairs.

## MEMBERSHIP

Alameda	Lindsay	Riverside
Albany	Livermore	Sacramento
Alhambra	Lodi	San Bernardino
Anaheim	Lompoc	San Buenaventura
Antioch	Long Beach	San Diego
Auburn	Los Angeles	San Francisco
Bakersfield	Los Banos	San Jose
Benicia	Los Gatos	San Leandro
Berkeley	Loyalton	San Luis Obispo
Biggs	Madera	San Mateo
Bishop	Martinez	San Rafael
Black Diamond	Merced	Santa Ana
Burlingame	Mill Valley	Santa Barbara
Calistoga	Modesto	Santa Clara
Chico	Monterey	Santa Cruz
Coalinga	Mountain View	Santa Maria
Colton	Napa	Santa Monica
Colusa	National City	Santa Paula
Compton	Nevada City	Santa Rosa
Coronado	Newman	Sausalito
Corona	Newport Beach	Sebastopol
Covina	Oakland	Selma
Crescent City	Ocean Park	Sierra Madre
East San Jose	Oceanside	Sisson
Elsinore	Orange	Sonoma
Emeryville	Oroville	Sonora
Escondido	Oxnard	South Pasadena
Etna	Pacific Grove	South San Francisco
Eureka	Palo Alto	St. Helena
Fairfield	Pasadena	Stockton
Ferndale	Petaluma	Suisun City
Fort Jones	Piedmont	Susanville
Fresno	Pinole	Tehachapi
Gilroy	Placerville	Tulare
Glendale	Pleasanton	Vacaville
Hanford	Point Arena	Vallejo
Hayward	Pomona	Visalia
Hercules	Red Bluff	Watsonville
Hermosa Beach	Redding	Whittier
Huntington Park	Redlands	Willits
Imperial	Redondo Beach	Winters
Jackson	Redwood City	Woodland
Lakeport	Richmond	Yreka
Lemoore	Rio Vista	

Every city belonging to the League of California Municipalities is entitled to a free copy of this magazine every month for each of its officials; if not received kindly notify the Secretary. See that your City is in the above list.



# PACIFIC MUNICIPALITIES

▲ Journal for Progressive Cities

VOL. XXIII

DECEMBER 31, 1910

No. 5

PROCEEDINGS

THIRTEENTH ANNUAL CONVENTION

OF THE

LEAGUE OF CALIFORNIA MUNICIPALITIES

HELD AT

SAN DIEGO, CALIFORNIA, November 15th to 19th Inclusive

1910

FIRST SESSION

TUESDAY, NOVEMBER 15, 1910, 2 P. M.

MAYOR S. C. EVANS, of Riverside: Gentlemen of the League, and Friends of San Diego—The thirteenth annual convention of the League of California Municipalities will now come to order—and we are in a very orderly mood—with due regard to the dignity of this League and due courtesy to the City of San Diego. I consider this League the most potent force in the State in municipal affairs. We are met for the furtherance of those things that pertain to municipal government, and are, in fact, the only agency that the cities, as a unit, have, by which to acquire those things which all reasonable men nowadays agree are necessary and advantageous for our commonwealths and our citizenship to possess.

Now, as I shall perhaps, later during the convention, have an opportunity to present a more formal address, I will not speak further to you at this time.

I believe it will be the consensus of opinion of those present and that you will not think that I am out of place at all or ill-natured if, during the sessions of the convention, I ask you to keep very closely to the subject-matter in hand, so that our speeches may be very short and to the point, and our questions suggested, and not followed by long arguments. Then, if some man strikes the keynote of a subject in which you are interested, you can note him and his name and city as he speaks, and afterwards hunt him up and talk to him in detail upon that subject. I believe by that means we can get the most out of the meeting. And to that end,

## PACIFIC MUNICIPALITIES

and that the reporter may know just who is talking, I will ask every speaker as he comes to his feet, to announce his name and city distinctly.

I am sure it is not necessary for me, in a preliminary way, to announce the gladness that is ours in being here in this city of San Diego. That will be done by subsequent speakers. But, as President of the League for the year, I wish to state to the people of San Diego that we very much appreciate your courtesy and the entertainment you have provided for us, and will continue to provide during the time that we shall be with you.

I have now the pleasure of introducing to you the Mayor of San Diego, Grant Conard, noted upon the program, to give you the address of welcome for San Diego, Mayor Conard. (Applause).

### ADDRESS OF WELCOME

GRANT CONARD, of San Diego. Mr. Chairman, Ladies and Gentlemen, and Delegates of the Thirteenth Annual Convention of the League of California Municipalities. It is my privilege and my very great pleasure, on behalf of the people of San Diego, to extend to you a most cordial welcome. I am glad to welcome my fellow city officials gathered here from all parts of the great State of California. I am glad to welcome you as citizens of this great State, that State which is destined to become one of the most important, if not, indeed, the most important in this Union of States.

Even our own residents admit that California is a great State. And, go where you will throughout the various States of the Union, let it be known that you are a citizen of the Golden State, and you are at once implored to impart information concerning our glorious California. Indeed, in traveling about this country you find that about one-half of the people you meet are making their plans to make their homes in California some time. (laughter).

Now, when we consider that California is the world's vineyard, orchard and granary; that this great State, nearly 800 miles long and 250 miles wide, with nearly a thousand miles of seacoast, is possessed not only of a fertile soil but a climate unsurpassed anywhere in the world; when we consider that this great State has been endowed with every good thing that man needs beyond any other region on earth, it is no wonder that we are attracting to our State a population of the best fiber that the American race has produced. And yet California, truly the garden spot of the world, is but sparsely settled. Larger in area than the States of Ohio, Indiana, Illinois, Massachusetts, and New Jersey combined, it has a population but little greater than New Jersey, which is smaller in size than any of several counties in the great State of California. But California is growing quite rapidly. The thirteenth census reveals the fact that some of our California cities have made a greater gain in percentage than those of any other section of our country.

While California is possessed of great agricultural and mineral wealth, it differs from other States in the fact that so many of our people who till the soil and work our mines reside within our cities. Nearly three-fourths of the population of California resides within the incorporated areas of cities. Therefore the proposition of municipal government directly concerns a large majority of the people of California. Municipal government comes nearer to us than any other kind of government. If the government at Washington or at Sacramento is bad, we perhaps read about it in the newspapers. But it does not so directly concern us. If, however, the government of our city is inefficient, it directly concerns all of us in that city. If the water supply is contaminated, it affects our health. If our fire department is

not efficient, our property, even our lives, may be endangered. If our police system is not sufficient, we suffer from non-enforcement of the law. If our streets are not properly kept, that affects our daily lives. If we do not have proper sewerage and sanitation, our health is affected, and our lives are endangered. If the money derived from the various sources of revenue is not wisely and judiciously expended, the taxpayer and citizen fails to receive that for which he has paid and to which he is justly entitled.

Consequently, the problems of municipal government come directly home to each one of us. With a rapid concentration of population in our cities, the government of cities becomes of greater importance, year by year. To my mind, there is no public service of more importance than that rendered by city officials. Mayor Gaynor, of the city of New York, who recently declined to allow his name to be used in connection with the governorship of the great State of New York, on the ground that he could perform a greater service as Mayor of the city of New York than as Governor of the State, has set an example of lofty patriotism which should be an inspiration to every conscientious city official throughout this great land.

Gentlemen, Delegates, I welcome you to San Diego. I am sure that this gathering of municipal officials from all parts of the great State of California, for the discussion of those questions which we, as city officials, are called upon to meet, will result in great benefit to every delegate here in attendance at this convention, and to every city here represented. The League of California Municipalities is a school of instruction where all may obtain knowledge and inspiration. It has been well said that it is a clearing-house of ideas. I may add that it is also a clearing-house of our troubles, where city officials of the various cities may bring their problems for adjustment, and, by comparing notes and exchanging ideas, give each to the other the benefit of experience and the methods used in the various communities. These annual gatherings are educational and instructive, and must be profitable to all.

We are glad that you have honored San Diego as your place of meeting. We sincerely hope that your short sojourn among us will be as pleasant to you as I am sure it will be to our people.

Mr. Chairman, I do not wish to interfere at all with your excellent program which you have prepared, and while we are all, no doubt, citizens of California, it is just possible that some of us may have been born in Missouri. At any rate, our citizens are very anxious to show you as much as possible of our beautiful and prosperous city while you are with us. I know that you have come here to work. Yet I would recommend to you the old adage that all work and no play is tiresome, even for city officials. Therefore I trust that you will permit our citizens to carry out the part of the program which we have arranged for our pleasure and we hope for your entertainment. I thank you. (Applause).

THE PRESIDENT. This is the first time that I ever heard that a city official had any work to do. I thought they played most of the time—at least, that is the common report.

We will now hear a response to the very generous welcome that has been extended to us by the Mayor of San Diego, and that response will be by Mayor Orr, of Visalia, known locally as the big tree orator of that part of the State, and representing a city which has aspirations of its own. Gentlemen, Mayor Orr. (Applause).

#### RESPONSE TO ADDRESS OF WELCOME

MAYOR A. R. ORR, of Visalia. Mr. Mayor of San Diego: We are pleased to



## PACIFIC MUNICIPALITIES

receive your words of welcome, we are pleased to be with you, and we sincerely hope that we may merit all that your citizenship has so thoughtfully provided for our entertainment. We came to meet with you on the square, but, since going over your city this morning, I know of no way that we can meet with you upon the level. Your workmanship is such, as shown by your handiwork, and it is representative of your people, that we find that feat impossible.

It was my pleasure this morning, in company with two of your townsmen, to search the borders of a portion of your bay, and along the line of that bay they have buoys, and at night time they have lights strung, in order to pilot vessels to your port. We also understand, Mr. Mayor, that the government has under consideration the matter of connecting a few of those points, in order to straighten your line, straighten it as here at this convention do the representatives of the cities of the State of California. You come here, gentlemen, to untangle the problem of city government. You come here with all your troubles, you come here with all the things that have been heaped upon you in your respective cities, and ask this body to solve them. Here is a city by the sea, a city that it was never my pleasure to see until this morning and I then arose at six o'clock to go out to try to get a fish—but there was not a single Portugese had one for sale. At Santa Cruz last year, it was my good fortune to go fishing in the early morning, and at the end of the wharf next to the land I bought three fish and pawned them off as mine—because I paid for them. (Laughter.)

But, as representatives of the other cities of the State, coming to you here in San Diego, we realize, and I realized this morning as I traveled about your city in some of the older portions and in many of the new, what can be done in an up-to-date and progressive municipality. I find evidences of good work in your macadamized roads and streets, entering your parks, climbing over your hills, leveling the elevations and connecting your depressions. You have been going some. You are very much like the man who was abroad and who believed in ghosts, and the ghosts pursued him, and he ran as long as he could and then stopped and sat down for a moment puffing, and the ghost came along and put his arm upon his body and said, "We have been going some, haven't we?" And the man replied, "Yes, and we will go a damned sight more, as soon as I can get my breath." (Laughter) I believe that you are on the verge of a rapid stride forward. I find there lying upon your waters, the protection that Uncle Sam gives to all of the country and its property. There, at the entrance of your bay, flies the American flag, the flag that no nation on earth dishonors. (Applause)

Here is an open port for the commerce of the world. Here is your energy, the picked forces of American citizenship, centered at San Diego. San Diego has begun a new growth. She has begun to broaden and grasp and bring in and manufacture and produce and send abroad, and is now looking for a waterway to the markets of the Orient. Keep on, and if the ghost still pursues you, travel faster. You are at that point of your progress now.

Throughout the great State of California, the State whose cities you gentlemen here represent, the energy and the vim and the enterprise, the pulsating power of American thought, is causing a phenomenal onward progress. Today, California, in every department, in her cities, in her country, in her mines, in her agriculture, in her commerce, is growing—growing with such rapid strides that even Californians can't keep pace therewith. It is the California of all of you, the California of everyone who comes to be with us, whether he be a Missourian and you have to show him twice or thrice, or not. When we speak of a Californian, he may be in San Diego or way up yonder on the northern coast, and yet he is a Californian

still. And this, by the way, is the first time I ever got to one of these extremes geographically, so that I could fittingly use that time-worn expression, "from Siskiyou to San Diego." Just as there is energy way down here at this end of the State, there is energy pent up and being freed at the other. You are all building up this State, are helping it to progress and will continue to do so. You, down in this end of the State will see the uprising of your energy, as in San Francisco after her great disaster. It is all the enterprise of California. And when you have passed your usefulness here, when you are called to that final home and you have those little wings to waft you on, you will say, "Please don't put them on. Give them to the residents of the East, give them to those that live elsewhere, but let me stay in California." (Applause)

I was not brought here to talk. The other past President of this association told me what to say, and I believe I have told it all. But I want to thank you, Mr. Mayor, for the invitation extended us to show us something. I am a Missourian, and only recently have I ceased to speak the language in all its purity. This morning I had a drive of thirty miles about your city in an auto. I observed its magnitude and the variety of conditions existing, appealing to the display of energy and opportunity for American brain and American thought, American energy and American capital. While those things exist, you have our best wishes in San Diego. To-day I saw the place where the vim and the energy, the life and the pluck of San Diegans, had declared "We will build for 1915"—and they will do it. (Applause.) They have selected, here in the heart of the city, their fourteen hundred acre park. In no other city in the State of California is a park of such magnitude lying within the heart of its residence district. That park is surrounded with new homes, American homes, and that means that those within are contented and prosperous.

I desire, Mr. Mayor, to extend to you the thanks of the visiting delegates for courtesies you have extended and are to extend. It seems that nowhere are we to be allowed to pay anything. Even the San Diego Street Railroad Company and the San Diego & Coronado Ferry Company have issued to you passes that you may use during your stay here. Why, San Diego is the most hospitable place I ever saw. Even in meeting the Chief of Police this morning, he said to me, "You can have full access to our local bastille, without the necessity of filing a complaint." I thanked him, and told him I would think it over and perhaps wait until later in the session before I accepted.

Mr. Mayor, we are pleased to be with you. We came to work with you, and with that work we trust to have some play. We thank you for the hospitality extended, and hope that all kinds of prosperity may be yours. (Applause.)

THE PRESIDENT. We have with us to-day, representatives of cities from two neighboring States. I will ask Mr. E. J. Murphy, Mayor of Pendleton, Oregon, and Mr. J. R. de Mattos, Mayor of Bellingham, Washington, to take the platform. (Applause.) I will ask Mr. Murphy to address you at this time.

MR. E. J. MURPHY, Mayor of Pendleton, Oregon. Mr. President, Ladies and Gentlemen: Up in my town, I am known as a worker and not as a talker. We have read a great deal in Oregon about your municipal conventions that you have been for so many years holding in the different cities of California, and my people asked me to come as a visiting delegate to learn something of what you are doing. That is my business here. I did not come to talk. But I am glad to meet with you, and I shall be an attentive listener, as I will have to take back with me some information as to what you are doing. We think it is about time that the State of Oregon should have an organization of this kind, and I believe that the

report I shall be able to give them will lead to the formation of one. I thank you, gentlemen. (Applause)

THE PRESIDENT. We very much appreciate the courtesy that these gentlemen have extended in coming to us. Mr. de Mattos begs to be excused at the present moment, as he has but just arrived, after all the fatigue of the long journey from Washington. We will hear from him later during the convention. I want to state also that the President of the City Council of San Diego, Mr. A. E. Dodson, invited the representatives of the neighboring State in Mexico to come up and attend this meeting of our League, and I understand that the Lieutenant-Governor of Lower California is to be with us. As members of this organization, I think we ought to do all we can to establish and maintain friendly relations with our sister republic, rather than to have the disturbances that have been going on of late, and especially so near to the borders of this State. We will now listen to the report of the Secretary of the League, Mr. H. A. Mason, of San Francisco—and that is a sort of perfunctory way of introducing to you a man who is well known to every one of you—and I cannot refrain from taking this occasion to express the appreciation of the League for the very able services that Mr. Mason and his assistant, Mr. Locke, have rendered this League during the past year, as, indeed, Mr. Mason has always done, and Mr. Locke since he has been with us. (See report of Secretary Mason in the number of November 30th.)

THE PRESIDENT. The Secretary has a few communications to read at this time.

(Communications from the Board of Trade of Visalia, Berkeley Chamber of Commerce and the Berkeley City Council, and from the City of Watsonville, to hold the next annual meeting of the League at their respective cities, were then read by the Secretary, and Mr. W. P. Butcher, of Santa Barbara, extended the invitation of that city to hold the next session there, stating that the City Council had passed a resolution to that effect.)

MR. HUGH CRAIG, of Piedmont. Mr. President, this report of our worthy Secretary should not be allowed to go in this perfunctory manner. I note that he says, on the financial side, that we started the year with something like \$27 in hand, and that we now have a balance of \$500. I move that the thanks of this association be tendered to the Secretary and his assistant for the very efficient manner in which they have attended to the duties of their respective offices during the present year, and that this motion be made a matter of record with the association.

The motion unanimously prevailed.

On motion the President appointed as an Auditing Committee, to examine the accounts of the Secretary, Mayor Strait, of Redlands, City Attorney C. N. Kirkbride, of San Mateo, and Councilman W. F. Hyde, of Palo Alto.

THE PRESIDENT. I now have the honor of introducing to you Mayor Beverly Hodghead, of Berkeley, who will address you on the subject "The Progress of Commission Government. (Applause.)

### THE PROGRESS OF COMMISSION GOVERNMENT

MAYOR BEVERLY L. HODGHEAD, of Berkeley. Mr. President, and Ladies and Gentlemen of the Convention: I am not accustomed, like all of my predecessors here this afternoon, of standing before the footlights, so I take refuge behind what appears here to be a barricade.

I spent about an hour this morning with Councilman Dodson of this city, looking for that city auto that has been referred to earlier in the proceedings to-day.



and not until Mayor Orr was in the midst of his peroration, describing with dramatic effect the manner in which he reached this southern extremity of that well-worn figure of speech throughout California, did I find out where that city auto was. I suppose that is because Visalia gets up a little bit earlier in the morning than does Berkeley.

Since I have been in San Diego, my conscience has been so entirely clear, and, indeed, so entirely at rest, that I did not awake this morning until after the breakfast hour had passed at the hotel, and I suppose that, if Councilman Dodson and Mayor Hanford had not hammered at my door at ten o'clock, I might have been asleep there yet. The thought occurred to me, however, when I did get up, that this is saving money for Berkeley, because I won't need but two meals to-day. However, by the time we had taken an hour hunting for that city auto, and another hour because we didn't find it, I found I had got up a pretty generous appetite at noon, and I took lunch today with our City Auditor, who has a great appetite for detail, and I didn't order everything I wanted, because I was afraid when I got back to Berkeley he would not audit the bill.

As you can perhaps see, this has no very close connection with the subject of the Commission form of government. Before I come to that, I want to say just one word in connection with one of the communications that has been read here this afternoon, coming from Berkeley, and that is, if you do not hear anything more about this invitation from Berkeley before the convention comes to decide upon the place of its next meeting, I want you to all feel assured that if you decide to come to Berkeley, that it will be considered by that city a great honor, and that you will be accorded a very hearty welcome.

The subject that was assigned to me here is, "The Progress of Commission Government."

My purpose in this paper is to state as accurately as the information at hand will permit, the present status of commission government in the United States and to give a brief account of its growth.

### THE EARLIER CHARTERS

A study of the principles of municipal government and their special application to the needs of the American city is a subject which until recently had received but little attention, but within the past few years has engaged much of the best thought of the country. During the past decade there has been a sort of renaissance in this important but neglected branch of government. Following the rural character of the early settlements came the growth of cities, then their misgovernment and lastly, it is hoped in some degree, the remedy for such intolerable conditions. The failure of the American cities, especially during the last half century, to give good government is well nigh universally admitted. Their inefficiency has been observed of all students of municipal conditions and in many instances they have furnished notorious examples of flagrant abuses and misrule. This condition has been due largely to civic indolence, to the neglect of civic duties, to the activity of one element, and the indifference of the other, but in part also to the attempt to apply a wrong system unsuited to the requirements of the well regulated municipality.

The city is a unit and its government should be simple in form, yet in the early charters the complex machinery of the federal government with all its checks and balances, its bicameral council and its executive vote were applied to these small centers of urban population as though they were miniature federations or communities with hostile interests; and to make the federal analogy more complete the city

was arbitrarily subdivided into a number of wards, purely artificial divisions, to represent and correspond in the federal scheme to the jarring interests of independent states. By this artificial division into discordant elements, of a population otherwise homogeneous, a false condition has been created. The federal plan was originally devised to meet certain existing conditions, but in attempting to apply it to cities, unnatural *conditions* have been created to meet the federal plan. The history of the government of American cities has not shown this system to have been a distinguished success.

A number of plans have been devised to remedy these evils. One has been the substitution of a single elective body for the bicameral council. Another, the concentration of large administrative powers in the mayor—a form of government of which the San Francisco charter is a type—and still a third was to give state boards or commissions control over municipal functions. None of these remedies strike at the root of the evil without which quality no political specific can have any permanent curative effect.

### GENESIS OF THE COMMISSION PLAN

The growing popularity of the commission plan of government is due to its own simplicity of method, and to the very general dissatisfaction with the complex form of the federal or American type of charter. The commission charter recognizes in the city a homogeneous unit with a community of interest, not an aggregation of discordant elements to be reconciled. It recognizes that the proper and efficient administration of the affairs of a city is a business problem, and not a political privilege, and that officers are to be chosen for their administrative ability, not as a reward for political service. It recognizes the principle that efficiency lies in concentration of power, not in diffusion of responsibility.

The genesis of this plan of government is familiar to all. When Galveston was swept by the flood of ten years ago, heroic measures were needed to save the city from financial ruin. The plan was devised of entrusting the entire administration of the city to five commissioners. Men of known integrity and business capacity were chosen for this work. The plan succeeded. It proved a sort of political vermifuge. The financial condition of the city was improved, all leakage and waste in the government were eliminated, the efficiency of the public service was increased, approved business methods were introduced, a dollar of public money had its full purchasing value. As the commissioners were selected to administer the affairs of the city and not merely to distribute its patronage, men were chosen for the various offices and clerkships for the work expected of them after their appointment not for that done before—for their business efficiency not their political sagacity. It was discovered that capable men influenced by political motives could accomplish more when given the power to act, than when blocked by the supposed safeguards found in the checks and balances of the old American type of charter. In other words the plan worked. It achieved results, and after its success was demonstrated, it was discovered that this was the plan already pursued in most successful private enterprises of larger proportions. The introduction of this new principle in municipal administration encouraged a different type of citizens to accept public office and the general tone of the public service was raised.

The success of this system in Galveston encouraged other Texas citizens to adopt it. After watching its operation for several years Houston procured a similar charter in 1907, followed the next year by Ft. Worth, Austin, El Paso and most of the principal cities of the state. The ill wind which swept over Galveston and destroyed the city, carried with it the proverbial good to others in that it started

another tidal wave which promises before its force is spent, to work a much needed revolution in the system of municipal government in the United States.

### THE DES MOINES PLAN

The influence of the Galveston example was not confined to Texas alone. Other interested communities were looking on. Iowa by the year 1907 was convinced of the success of the experiment under the new organic law. Then followed the Des Moines plan which adopts the main features of the Galveston system, but makes some decided improvements and remedies some of its glaring defects. The Des Moines plan recognizes the value of a capable commission composed of business men removed from political influence, but it devises a plan more likely to secure such type of officer. It not only centralizes responsibility but provides for its proper enforcement by the adoption of the initiative, the referendum and the recall. It also introduces the principle of the non-partisan primary for the nomination of candidates, free from the influence of political party or convention. It reduces the number of candidates to two and thus establishes the principle of election by majority.

The spread of the commission plan during the last three years has been along the lines of the Des Moines charter. There is no method provided in the Galveston charter for nomination of officers. This is left to party conventions and controlled by partisan influences. That charter offers an excellent opportunity for a business administration to do effective work, yet it provides no method for insuring the selection of such type of officers. While it emphasizes the business aspect it overlooks the democratic character of the government. It imposes responsibility, but provides no effective means for enforcing it. For these reasons the Des Moines plan would seem to be a superior and safer type of charter, and has proven uniformly successful wherever it has been adopted.

It has been followed in a number of the Iowa cities, in Kansas and Missouri and in a number of the cities of the Pacific Coast. Some features of the commission plan have been adopted by the cities in North Dakota and in several of the eastern states. Your own charter in San Diego adopts the main principles of the Des Moines plan, yet retains the power of veto in the executive and continues that office as a separate and independent branch of the government.

I have a clipping here from Lynn, Massachusetts, cut from a magazine yesterday morning, stating that that city of 90,000 people had just adopted a commission form of government.

I think that is a misinterpretation of that system oftentimes, that it is understood to be some reflection upon or some revolt against a former corrupt condition.

It is not intended for that at all, but simply to be the organization of a more efficient system of government.

### THE BERKELEY PLAN

The process of charter making advanced another step in the year 1909. Galveston originated and Des Moines improved the system, but I think it will be admitted that the commission form of government finds its latest expression and is brought nearer to an effective plan in the Berkeley charter which was ratified by the legislature of two years ago.

The chief difference between the Berkeley charter and the Des Moines plan is in the provision relating to elections. The Berkeley system recognizes the fact that government is more a question of men than of charters; that no less important than the extent and character of the powers granted is the selection of the officers



## PACIFIC MUNICIPALITIES

who are to administer those duties. It pursues still further than the Des Moines charter the analogy of the business management of public affairs and gives more emphasis to the distinction between the business and political methods of choosing such officials. It not only devises a system for the nomination of candidates who shall be free from partisan influence or control, but in whose selection the non-political or business element of the community is induced to exercise a dominant voice. In other words, the aim of the charter is to secure the nomination and election of candidates not so much by place hunters, as through the influence of those citizens who have no personal ends to serve. Under such system the officers chosen will likely be those who *consent* to serve than those who *seek* to serve. To accomplish this end Berkeley originated and adopted the system of dual elections. The first election is a primary or final election according to the result of the vote. If any candidate for any office receives a majority of all the votes cast he is elected. If no candidate receives such majority then that election serves as a primary for the nomination of candidates in accordance with the Des Moines plan. The value of this feature of the charter lies in the fact that this first election loses the aspect of a mere primary and arouses in the ordinary citizen the interest that he takes in an election where a choice is to be made. In other words, it brings out a vote from this non-political element of the community and gives the people not only the power but offers them an inducement to make their own nominations. To designate their first election a primary merely, as under the Des Moines plan, would be to invite to some extent the difference which is too often displayed toward primaries by the non-political element of the community.

The Berkeley plan therefore, insures not only an election by a majority vote, but it is held under circumstances which induce the fullest expression of opinion. At the last primary election held in Berkeley under the old system for the election of delegates to a convention to nominate city officers, the total vote cast in the city was 731. At the first or primary election held under the new charter two years later, when the population was practically the same, the vote was 5025, which was also 25 percent greater than the total vote cast at the general election which followed. The primary is of importance equal to the election itself for the reason that the officers are to be chosen from the candidates nominated. It is therefore important that the public interest be aroused at a time when its influence will be most effective.

The City of Tacoma embodied the Berkeley plan in its new charter adopted last year. At the first or primary election the total vote was about 10 percent larger than the vote cast at the general election which followed. The result was different, however, in Colorado Springs which also adopted the Berkeley plan. The vote in that city at the first election was somewhat smaller than at the second. The mayor gives as a reason for this that it was a foregone conclusion that no candidate would receive a majority of the vote required to elect and therefore the voters did not turn out at the first election. That was a false impression to circulate, but it demonstrates this fact, that it is the possibility of electing at the first or primary election which brings out the vote. In Des Moines and Cedar Rapids and San Diego and in fact, in all the cities from which reports have been received which merely nominate but do not elect at the primary, the vote has been smaller than at the general election.

The Berkeley Plan has been followed in the new charter recently adopted in Modesto, and with the exception of the feature of dual elections in the proposed charter of Oakland, which has been completed by the freeholders. Also in the draft of the new charter of Sacramento, which has been prepared by a committee

of citizens. It is receiving favorable consideration in Vallejo, Stockton, Petaluma, Long Beach, Monterey, Santa Monica, and Santa Cruz. The charter committee of San Francisco after considering the modern forms of charter recommended the Berkeley plan of dual elections. The election is in progress in that city today on the question of its adoption, with a reasonable prospect of its carrying. I say reasonable—not quite so reasonable as a few days ago, because the present administration in San Francisco and perhaps the labor vote, have come out strongly against the plan. It is under consideration in a number of the cities in Washington, and in some of the Eastern states.

One of the most instructive articles, descriptive of the Berkeley system, has been prepared by Prof. Reed, instructor of civil government in the University of California, to be published in an early number of the North American Review.

There has been some question as to the constitutionality of this feature of the Berkeley Plan which in effect results in election by majorities, inasmuch as the constitution provides that in all elections a plurality is sufficient for a choice. I doubt if that section is applicable in elections held under freeholders charters, but conceding that it is, there does not seem to be any conflict whatever. The Berkeley plan merely provides in effect that a first election shall be held for the nomination of candidates, (which is entirely regular) and that in case any candidate receives a majority of votes he is elected, which in no way infringes on the constitutional rule.

It has been contended that it is better to give the people an opportunity to make a final choice for a given office between two candidates, but if the result of the first election is so emphatic that the majority of the people express a preference for one candidate over a number of candidates combined, I see no reason why they should again be required to express a preference over a particular one among that number. There would be just as much logic in having a third election to see if the people had changed their minds again.

It has also been objected that the Berkeley plan would permit of the practice of plumping which is assumed to be a political evil, but this system was adopted under the impression that it would be a cure for that practice as there is even less opportunity for its use than under the Des Moines plan. Where a plurality only is required, the agreement of a considerable number of directors to cast their votes for but one candidate, although there are several to be elected, has a tendency, of course, to give that candidate a greater proportion of the total vote than he would receive. But the Berkeley plan is based upon a majority election. The successful candidate must receive a given number of votes. It is not sufficient that he have more than some one else. So it does not help in the least to elect your candidate by refraining to vote for another one.

It may be admitted that no perfect rule or method can be formulated for insuring in all cases the election of proper officers, for politics is an adjustable mechanism. It readily adapts itself to circumstances and its pranks follow no set rules. It is certain however, that no system can be devised which will result in the nomination or election of non-machine candidates unless the non-machine element votes. For that reason I regard the Berkeley plan of election as an advance in the system of municipal government, because it attaches more importance to the first election, which both theory and experience teach will induce a fuller expression of opinion from the non-political or business element of the community. The weakness in the republican government lies in the system of choosing officers. The danger here lies in civic indolence and private self interests. The way to get politics out of government is to get public sentiment into it. There is not so much

difficulty in getting the ordinary citizen to vote right, as to get him to vote at all. In my judgment the Berkeley plan is to be commended and will ultimately prove to be the safest plan, not because it devises any particular method for discouraging the machine vote, but because it is designed to induce a full expression from the non-machine voters at the incipient stage of the process of election. While no plan is perfect, the best system is the one which results in the largest vote, not only at the election but at the nomination which is equally important.

#### SOME MODIFICATIONS OF THE COMMISSION PLAN

There are some interesting and significant modifications and adaptations of these different plans of charters. Some of these have already been referred to. Some charters provide for the election of the commissioners to their respective departments instead of leaving their assignment to the council. My judgment is that such plan is directly contrary to the theory of the commission form of government. It destroys the very unity of action which the commission form was designed to secure and which is one of the strongest attributes of the system and would tend to divide the government into that number of distinct and independent parts and thus invite friction and engender antagonisms and jealousies. The same is true of the provision in some charters placing the sole right of appointment of chief officials in one commissioner instead of the whole council which would tend to result in a discordant and inharmonious policy. The commission plan of charter does not vest the power in one man nor in a multitude of officers, but in five or some small number, each of whom exercises a voice in all the affairs of the city. The election to particular departments would be likely to result in the choice of technical men suited possibly for that specific work, but more likely unsuited to be a general director of all municipal business.

Some charters retain the veto power in the mayor. I think the influence of that officer exercised by his vote on all questions and by his deliberating on an equal plane with the other members of the council has a far more potent effect than that exercised through the veto on their actions which is seldom used. I am informed by the city clerks that the number of ordinances vetoed in the various California cities in the past two years is as follows: Pasadena 1, Oakland 1, Alameda 1, Sacramento 4, San Jose 3, Riverside none, Long Beach 10.

There seems to have been scarcely no occasion for the exercise of the veto. The mayor's vote and advise on pending questions it seems from experience would be a source of greater usefulness. If any check be needed upon the action of the council it is readily supplied through the referendum.

#### WILL THE COMMISSION SURVIVE?

The essential feature of the commission system is the mingling of administrative and legislative functions in one small body of representatives chosen from the entire electorate. To these are added various methods for non-partisan nominations and elections with a short ballot making the issue clear and distinct, and provisions for the exercise under proper restrictions of the initiative, the referendum and the recall. Such a charter is in direct conflict with some of the cardinal principles of the old American type which seeks to separate the legislative from the executive departments. But the success of that system as applied to municipal government during the last half century has not been so conspicuous as to encourage us to adhere too rigidly in this connection to governmental traditions.

The commission plan has been adopted in sixty or seventy American cities, not hastily, but after its operation had first been scrutinized for a number of years in those few cities first adopting it. In Galveston it has been in force almost as long



as the San Francisco charter, which they are seeking now to amend or abandon. The system has been in operation for a period of one to five years in the other cities referred to. So far as I can ascertain it has been uniformly successful. The ordinary period for reaction has passed. It is beyond the stage of mere theory. Experience is beginning to teach something and we may now ask the question "Will it work?" The answer is that in no city where it has been adopted has there developed any opposition to it or been any tendency manifested to revert to the old plan so far as ascertained. Though the opponents of the plan have been waiting with some anxiety for an instance, no city has recorded any failure. In none has there been any abuse of power nor corruption in office. In none have the success and improvement prophesied failed of some measure of achievement. There is no case where the objections urged and dangers attributed to the system have not been proven by experience to be unfounded. It has been adopted as stated in sixty or seventy cities. It is under consideration in as many more. Wherever its adoption has been defeated it has been by the strength of the element opposed to good government and favoring machine politics.

Improvements no doubt will be suggested from time to time, drawn from a fuller experience with commission charters. But the reforms which they have already accomplished and the improvements in general municipal conditions which their introduction has effected, indicate very strongly that this movement which has already attained very general proportions for changing the government of cities from a political to a business basis, is no spasmodic upheaval or passing away of reform, but is a prudent and thoughtful transition to a permanent and lasting system. The editor of one of the leading magazines who has given the subject very careful study, expresses the opinion in a late issue that the commission form of government for cities is the most important contribution in American history to good government in the United States.

The advantages of the plan are that it gives the people a greater voice in the selection of their officers and brings them in closer relation to the administration of public business. It encourages a class of men to accept office who under old conditions were aloof to aspire to a public position. It makes a business of government which has heretofore been an incident of business. It enforces a consistent policy by giving the power to one set of men.

The chief merits of the system as expressed in the latest type of commission charters lie in the above attributes, and in the popular method of selecting officials and their responsiveness to the public will; the business method of administration with its resultant simplicity, promptness, efficiency and economy.

In the small council the powers of the city are centralized, the responsibility fixed, and the fault, if any, is easily located. Much of the business of a city is purely administrative and a small council of capable business men can execute its functions with greater efficiency and dispatch.

The abolition of the wards removes the dangers of antagonism between different sections of the city by removing the incentive for a councilman to favor the particular section or rather the dominant faction of the section which elected him.

I take it very much of the inherent difficulties with cities operating under the ward system comes from the fact they do act under the ward system, the tendency of members to favor their own particular wards, each fearing that his ward will not receive the same benefits as another ward—a tendency, in other words, to represent a part of the city and not to represent the whole of the city. The hardship of that situation seems to me to be strikingly illustrated in an incident which I read in one of the recent law journals, about a trial that took place in a middle western State,

in which two small villages were engaged in a contest over some matter or other, and in a murder trial, the jury was selected, six from one and six from the other, and the case was tried, the evidence all put in, the cause argued to the jury, and the case submitted to them. The jury went out, and they did not report an agreement, and they were called in and the trial judge kept them out another twenty-four hours, and still there was no agreement, and then the Court asked the jury if their disagreement was over a question of fact or a question of law, and one of the jurors spoke up and said they had not considered either the questions of law or of fact, because they could not agree on the selection of a foreman. That is the ward system.

The system which gives the power to one body of men and makes them responsible, and which thus co-ordinates and unifies the administrative departments of the city government is superior in my judgment to the disjointed policy of divided authority and independent action by different elective officers not accountable to each other nor to any one else.

As far as I have been able to ascertain the system is satisfactory to the chief officials in Berkeley who hold their offices during the pleasure of the council. They have learned that their tenure depends upon the quality of service, which is a matter under their own control, and not upon political strength which is a shifting and uncertain tenure. They have this incentive to do efficient work and are relieved of some responsibility by being able to counsel with the governing body of the city.

The Berkeley charter has resulted in non-partisan and non-political administration. The councilmen have absolutely no restrictions upon the full and free exercise of their business judgment in all matters. They are not embarrassed by the importunities of office-seekers, nor of their friends. No one has asserted any claim to office or other favor as a reward for political support. We have had no balancing of the respective political strength of different factions, and in this way have escaped one of the greatest difficulties and obstacles in the way of successful municipal government. All the officers of the city are appointed by the council except the auditor, and yet there is no more politics in making the appointments than in the ordinary employment of the foreman of a factory. I attribute this result largely to the charter.

The proceedings of the council during the fifteen months since the charter has been in effect have been entirely harmonious and quite unanimous. This is due largely to the fact that the members of the council have not prejudged questions and have not attempted to act independently of each other. But in all questions of policy our judgment has been deferred until after full investigation of the facts, and full conference and interchange of views. Where no member represents any interest or faction, and has no ulterior motives, I can see no more reason why under these conditions councilmen should not be able to agree as readily as the appellate courts agree upon the proper judgment to enter in any case.

The initiative, the referendum and the recall find their justification in the commission charter in the fact that all other checks and restrictions upon the action of the council are removed. I believe in representative government. It is necessary for efficiency. But the commission plan is the highest type of representative government. Considering the extent of the powers granted and the element of chance in elections, I think some remedy or check should be reserved to the people in case of a violation of trust. But these remedies to remain useful and effective should be guarded with such restrictions as will prevent their abuse and forestall unwarranted interferences with the proper administration of the business of the government. The

city should not be thrown into the turmoil and expense of frequent elections because some individual, or set of individuals feels it has some fancied grievance or some politician or agitator imagines he has a new toy. The abuses in representative government have resulted in the tendency to substitute a more democratic form. If in turn these democratic privileges, namely the initiative, the referendum and recall are themselves abused by being resorted to needlessly, it will no doubt likewise ultimately result in their abolition. They may be useful expedients but should be rarely employed. Their mere existence has a wholesome effect. Their usefulness however, would be weakened if frequently invoked, particularly if no vital issue or policy is involved. It is to be hoped however, that some more satisfactory method may be devised for initiating proceedings for direct legislation than by the present loose system of petitions, which, owing to the wellknown thoughtless practice and accommodating habit of signing petitions of whatever nature, but too often represent only the hopes and desires of the promoters of the proceeding rather than the well considered judgment of the great body of signers. It often happens that the signers of such petitions are absolutely the least informed about their contents and objects and thus the voters by the misuse of the privileges granted may subvert the very purposes of these remedies.

Government by petition if the privilege is wisely exercised is a valuable right, but if it be abused, it may be productive of more harm than good and eventually defeat its own purposes. It is more important that the petition be genuine than that it be large. It is important that it represent the deliberate judgment of the petitioners and that they appreciate fully the responsibility exercised in signing it. The proposed new charter of Oakland has introduced some valuable suggestions. It requires the petitions to be prepared in such form and the caption to be in such bold type as to indicate clearly to the petitioner that he is undertaking to put the city to the expense of a special election. It is required also that the petition contain not only a copy of the ordinance but also a brief statement of the reasons for its adoption and in similar form a brief statement of the reasons urged against it, or in case of a recall a statement of the incumbent justifying his position. The petitioner is required to certify that before signing he has carefully read the full contents of the petition.

There are many interesting questions which could be discussed in connection with commission forms of charters. I have only touched upon some of their chief features with more especial reference to the Berkeley plan.

The old washerwoman of DesMoines, the wife of a street laborer expressed in a homely phrase the real philosophy underlying the whole system of commission government, when in answer to the question how her husband was getting along, she said: "He is not doing very well this winter. You see the city has a new plan and there is no work when there is nothing to do."

I believe that in the light of experience these principles may be safely followed in the preparation of city charters:

1st. That few officials should be elected, the short ballot being a necessity of intelligent public selection.

2nd. That candidates should be nominated only by petition of a small number of electors:

3rd. Candidates in twice the number of officers to be chosen should be selected at primary provided that a majority vote be at such primary equivalent to election.

4th. That all legislative and administrative functions be vested in one small body to be chosen by the entire electorate instead of by artificial divisions or wards.



5th. That provision should be made for the use of the initiative, referendum and the recall in proper cases, but to prevent the abuse of these remedies their exercise should be guarded with such restrictions as will tend to insure the genuine character of such petitions.

I thank you. (Applause)

CITY ATTORNEY W. P. BUTCHER, of Santa Barbara: Mr. Chairman, is this paper now open for discussion?

THE PRESIDENT. It has been suggested that we listen to Mr. Dodson's paper, which is next on the program, before we enter upon a discussion of it. It gives me great pleasure, gentlemen, to introduce to you Mr. A. E. Dodson, President of the Council of San Diego, and Superintendent of the Departments of fire and sewer, who will address you on the subject of "Advantages of the Commission Form of Government in San Diego". (Applause.)

### ADVANTAGES OF THE COMMISSION FORM OF GOVERNMENT IN SAN DIEGO

MR. DODSON: Mr. President, and Ladies and Gentlemen: I am glad my friend Orr let the cat out of the bag, for I was considerably worried myself as to what had become of that auto. I had Mayor Hodghead under my arm, and we only had three-quarters of an hour to find the auto. Now we know all about it.

Last year it was my pleasure to present this paper in regard to the commission form of government. I did it with a great deal of misgiving. I was treading on unknown territory. I was a newcomer in your convention, and I did not know how my ideas would be received, and I was then very glad to see that it was appreciated, and then to have it supplemented by the very interesting paper by my friend Hodghead of Berkeley. While I cannot promise you as scholarly or as able an article as Mayor Hodghead has presented to you, I will give you the best I can do. I will say that the commission form of government gives satisfaction in San Diego, and I will try to show you in this article some of my views.

Those connected with the administration say it is a success. Those who are down and out because of the necessary changes resulting, those who had soft jobs with little work, those who had a pull and could charge the city government all the tariff would bear, and those who got easy contracts, say that the new system is a failure. One of our local dealers recently condemned the present administration because he "couldn't sell the city anything without being the *lowest bidder*." This man unintentionally gave one of the strongest compliments to the Commission Form of Government.

While our daily papers have not given the administration a very strong support, the weeklies have been quite loyal, and I take the following clipping from the Labor Leader of the 5th inst. As it is a voluntary tribute and based upon no consideration other than in the interest of good government, it evidently reflects the views of the average citizen:

"Since adopting the Commission Form of Government, San Diego can boast of being one of the best governed and most progressive of the cities along the Pacific Coast. When this form of government was adopted, the people of San Diego were fortunate enough to elect a set of honorable and able men to act as commissioners. From the Mayor down we have a most capable set of city officials and all of them are worth every cent which they receive for their services. It would be impossible to tell all the reforms which they have brought about in the conduct of the city's affairs, but we feel that they deserve a little notice in this large addition of our paper. They have been faithful to our people and we want our readers and friends

to know that our members appreciate the service which these men have performed for our city.''

The division of the duties of the City Government among the several councilmen as superintendents of departments, enables each to manage and control his department, and he is entitled to his credit or responsible for its favor. There is no shirking of responsibility and you can know where the blame should be placed. The old form was one of divided responsibility. The Board of Works or Police Commission could throw the blame upon the council or mayor, and they in turn could pass its matter back.

Formerly the council would formulate a plan and the execution would be left with the various executive officials. Where these plans were fully matured, (which could hardly be expected from men who could devote so small a portion of their time in their formation) and they were carried out as originally planned, success could be expected, but too frequently a partially matured plan would be passed to the Board of Works, or one of the other departments, who at once saw its defects, and in an attempt to improve it would so change it that the father would not recognize the child. Under the present arrangement the execution of a plan is completed by the source from which it originates. Under the old plan every member of the council was in a way held responsible for and was supposed to familiarize himself with all branches of the city government, which was an absolute impossibility from its magnitude, and also because he only devoted a small portion of his time to these duties and if necessary could not be fully informed. Instead of generalizing the present system requires the superintendent of each department to watch the details of his own department. As a balance wheel, however, his legislative duties require a general knowledge of every department, something he is more able to do than under the former system.

In National or State Governments, where a familiarity with local details is an impossibility, one branch of government must of necessity be legislative and another executive, but in municipal affairs where each councilman is in touch with local conditions, it stands to reason that he is more competent to carry out the intent of the legislative branch of the city government than to delegate it to another body for execution, particularly when such second body is unpaid and composed of men who have other duties requiring the greater portion of their time. Therefore, in my opinion the change in form of government has the following advantages:

First. All the advantages of that difference to be expected between business conducted by personal attention and that made a secondary consideration.

Second. From the fact that the city obtains labor and supplies at the market price and gets what it pays for.

Third. That of knowing where credit is due for success, as well as to know where to place responsibility in case of failure.

Fourth. The advantage of individual and special responsibility through the heads of departments, compared with the former system of divided responsibility.

Fifth. In the fact that the people can make their own selection of officials without party organization or boss dictation.

In summing up the above advantages of our present form of municipal government, we must remember that our councilmen are paid a fairly good salary and are expected to devote practically all their time and energies to the duties of their offices, while former councilmen received nothing for their services.

Without any attempt to boast about the rapid growth of our city, I am com-

pelled to refer to it, otherwise comparisons would not do the subject justice. Had our city's requirements been the same this year as they were in 1908, the subject would be easy, but there is a great difference. The rapid growth of our city and the consequent increased requirements are evidenced by the clearing house receipts of \$56,000,000 up to date, which, at a conservative estimate, are from eighty to ninety percent greater than those of 1908; also by the building permits, which, for the first ten months of 1910, amount to \$3,000,000, and show an increase of about thirty-five percent over those issued for the entire year of 1908. You can thus form some estimate of the increased expense of conducting the city government. Yet, with this great demand, we have about completed this year on a tax rate of \$1.30 per hundred dollars valuation, while the amount required in 1908 was 1.48 per hundred dollars. Take our Fire Department alone as an example of increased demands. In 1908 it obtained only \$41,382.81, while in 1910 it cost \$82,600.00 to protect the city in its rapid growth.

I have used the years 1908 and 1910 for comparison because they represent the last full year of the old form of government and the first full year under the new plan.

Believing the above advantages have been established, let us consider the

### RESULTS

Law and order never was as well administered as now. Saloons respect and obey the law as never before, and their power to control the election of municipal officers is a matter of the past.

The Fire Department is based upon merit and efficiency and not upon a political pull.

The same rule applies to the Police Department.

The Street Department makes street improvements with a view to permanency and it is free from red tape, which formerly existed.

The Water Department has been enabled to enlarge its water system and complete some splendid storage reservoirs.

The Sewer Department makes all its extensions by the day's work plan, finding it cheaper, and obtaining a better class of work than under the contract plan.

The Finance Department obtains city supplies at as low rate as any other corporation and takes advantage of cash discounts. In other words, the city not only pays for what it gets, but gets what it pays for.

Last, but not least, the familiarity of the heads of the various departments with the details of their work, has produced results impossible under the former plan.

From my acquaintance with the various officials who compose the League of California Municipalities, I believe you are earnest and sincere in your efforts to advance good government in your local communities, as well as desirous of raising the standard of municipalities throughout our favored state of California. These annual gatherings are beneficial and broadening. Each city has experiences peculiar unto itself, and the friendly exchange of ideas results in much good. While your experience may not have presented to you the same objections that I have found to the form of government, generally in force in our state, and the criticisms I make may not be justified by your experience, I hope for a fair hearing as I am attacking the old plan, formerly in vogue in this city.

I shall endeavor to show some of the evils of the old form, and so far as possible, suggest a remedy. The first matter to consider is



### WARD REPRESENTATION

A representative from a ward is dependent upon the support of his ward for re-election, and in the order of things, is expected to be interested in the welfare of his locality and frequently interested in making positions for his friends. To be able to secure for his ward or his friends such favors, he naturally must stand in with his fellow members who have similar axes to grind.

The larger the council, the more friends to be cared for and thus he perpetuates the spoils system. It does not take a Solomon to see the evil results of this system. By our commission plan we have a small council elected by the city at large, and as our duties are divided into departments, each of which embraces the entire city, councilmen thus selected are the representatives of all of the people and not of any particular subdivision of the city.

### UNPAID COUNCILMEN

In small towns where the duties of a trustee or councilman require but a small part of his time, he usually gives good service to his city without remuneration. The best men in the community are usually placed in these positions and perform their duties loyally and efficiently, but in cities where large sums of money are expended each year in public improvements and where familiarity with the subject matter requires constant and intelligent attention, it is not right to expect such officer to devote all of his time in the duties of his office without remuneration.

If he be a poor man, or a man of moderate means, he cannot afford it, and experience has shown us that very few men of wealth will consent to occupy such positions and take the cruel abuse which so frequently follows a man who consents to serve the public.

No private corporation would for a moment consider the service of a man who would give good time and efficient service without remuneration. The municipal government is entitled to the best service it can obtain, and should expect to pay for such service. It may be true that in old settled countries where municipal problems have been settled and where the duties of the legislative bodies are routine, and where the public official is, as a rule, an honest man, that wealthy men can assume the duties of office from a sense of duty, but in the growing cosmopolitan cities of America, this is not a successful plan. Either the city will suffer from inefficient service or some interest adverse to the welfare of the city will get control. In either case, the city must be the loser.

### SHORT TERM OF OFFICE

There is no doubt that the system of changing the personnel of a council every two years is wrong. We require that an engineer, a doctor, or a plumber shall have had previous experience before we trust him with our life, health or property, and on the same ground of reasoning, a councilman should have ability and experience. He certainly is more capable after two years service than he was at the beginning of his term, and should be worth more to the city than a new man would be. You may say to this that if he is not the right man, you can drop him at the end of his first term. In reply I answer that if the people do their duty as provided for in our San Diego Charter, they need not elect him the first time and that the recall can be used when occasion requires at any time. Vigilance on the part of the people will remedy this evil. Such vigilance, however, must be permanent and not spasmodic.

## PACIFIC MUNICIPALITIES

### PARTISAN NOMINATION

Why partisan control should be permitted in affairs of a municipality is a question often asked but never answered satisfactorily to the tax payer, although, by indifference or absence of better method, he quietly acquiesces by walking up to the polls and voting for candidates named in a caucus presided over by a ward heeler and under dictation of the boss. European cities have long since been redeemed from partisan and corrupt rule and will never return to the old order of things. American cities are giving serious attention to these matters and by the rule of evolution are getting better. The American people will not recede from the improvements being made in ballot reform and the dethronement of the municipal boss. It requires time, patience and courage to succeed, but the welfare of the State and nation is dependent upon striking a death blow to municipal misrule. As water does not rise above its source, neither can we expect national or State affairs to be correctly administered if we are unable to properly control our local government. The remedy is in the hands of the voter if properly used. No plan has yet been devised where this can be more intelligently practised than by our

### NON-PARTISAN DIRECT PRIMARY

By this plan any elector, on a petition, can become a candidate and submit his name at the primary. From the names presented alphabetically, without party designation, every voter has an opportunity to choose his candidates, and has the second opportunity of expressing his choice of the candidates thus selected. The officials so selected are the choice of a majority, and not of a minority, as is frequently the case under the convention plan. By the use of the direct primary the voters do not show that indifference so common under the old plan. When the voter realizes he is having a voice in public affairs he avails himself of the opportunity.

### THE INITIATIVE, REFERENDUM AND RECALL

While these prerogatives are sometimes misused and abused, and cost the expense and annoyance of unnecessary elections, they are of inestimable benefit to the people. While they are intended to keep public affairs under control of the people they are also a wholesome check upon one who is dishonest or who fails to represent the wishes of the people. Under our charter all franchises lie over thirty days before becoming operative, during which time a referendum petition will cause the grant to be passed upon by the voters. A petition of 25% will recall any officer and he must be sustained by a majority of voters to retain his position.

As stated by Mayor Hodghead of Berkeley:

"This power of the initiative, to remain useful and effective, should be guarded with such restrictions as will prevent its abuse and forestall the unwarranted interference with the proper administration of the government. \* \* \* \* \*

Government by petition, if the privilege is wisely exercised, is a valuable right, but if it be abused, it may be productive of more harm than good and eventually defeat its own purposes."

There have been but two petitions filed during the present administration. One was submitted to the people at an election held for other purposes. The other, being insufficient in number of qualified petitioners to require a special election will doubtless be presented for submission at the next general election. The average person is too ready to sign a petition without investigating its merits. Some method should be devised to cause the petitioner to realize his responsibility in

such matters. He should not cause the expense of an election unless absolutely necessary, otherwise he is bringing into disrepute and abusing one of the strongest safety valves within his control.

### PUBLIC UTILITY CORPORATIONS

As shown above, all franchises are subject to the referendum, and should a council give unreasonable or improper grants, the power of control remains with the people. This should remove to some extent, the temptation for corporations to elect henchmen to look after their interests, because if their demands are fair and honest they can trust their chances with the people, who, as a whole, may be relied upon; and if they are asked for improper privileges the people have it within their control to deny them. The average citizen realizes that corporations are entitled to fair treatment and a reasonable return upon their investment, and are willing to concede it, but the corporations that desire unreasonable or special privileges must be controlled by the people from whom they derive their right to exist. They are creatures of the law and are subject to its demands.

### PERSONAL RESPONSIBILITY

Is one of the strongest features of the commission form of government. As the affairs of the city are divided into departments and each councilman is the superintendent of a department, he is held responsible for its conduct. There is no shifting the responsibility. If he succeeds he is entitled to the credit, as well as to be blamed should he fail. He is personally in touch with the execution of every detail. It requires his whole time and best efforts. All money appropriated to his department is expended under his personal direction. Under the old haphazard plan the Council or Board of Works voted expenditures for purposes with which they were not and could not become familiar. They, being mostly unpaid officials, had to leave the expenditures to the hired man with little or no system of checks upon him. In letting public contracts they did the best they could but were dependent largely upon the honor of the contractor. It is quite common today, to find long lines of sewer pipes which, on the maps show Ys and laterals, that in the ditches have been omitted, although the city paid for them. Our experience shows it to be considerably cheaper to have sewers laid by the day's work than by contract and we have the assurance that the work is done better. In other words, it pays to do the business of a city as you would conduct the affairs of private corporations, except that while the private corporation is conducted with a view to profit, the municipal corporation should be managed to give the most to its stockholders—the public—at the least cost commensurate with good government. We must insist that the city government is not an institution whose principal object is to give soft jobs to friends and fat contracts to those who have the pull. The same loyalty to its affairs must be demanded of city officials as is required by private corporations and the same standard of efficiency and experience should be expected. When we recognize public service as a profession and place only trained men who realize that their tenure of office is dependent upon efficiency of service, as is the custom in European countries, then will our municipalities be able to grasp the control of public utilities as is done there. This question might be successfully reached in time by the commission form of government, but under the old form, never.

### REFORMS ARE SPASMODIC

The average reformer is inconsistent, and most reform movements are spasmodic. In every city there should be a permanent organization not so much for



the purpose of general reform, but rather a society that would make it a special object to keep fully apprised of its municipal needs and assist officials who are endeavoring to do their duty. A little advice given in the right spirit, from citizens who have no axes to grind, will accomplish much more than criticism. The press could also do the community a favor by boosting instead of knocking an administration. Such an organization as named, together with a press loyal to the best welfare of the community, could accomplish much for the general good. It should, however, be permanent and after each campaign or public issue, get in line for the next. By a continuous, determined and intelligent course, a community can be so elevated to that moral standard and civic pride that nothing but subsequent apathy would ever cause it to return to its former polluted condition. Such a reform can only be obtained by bringing the people into a full understanding of their duty in the premises. (Applause)

THE PRESIDENT. The general subject of the commission plan of government is now open for discussion. Mr. Butcher, of Santa Barbara, who rose to discuss it before the reading of Mr. Dodson's paper, will be given the floor.

MR. BUTCHER. I notice, Mr. President, that we are expected to be very pointed in our remarks on these papers, and not waste any time in eloquence. I want to say, however, that I think Berkeley and San Diego are to be complimented on having two excellent officers now in charge of their affairs, whose earnestness and insight I am satisfied no one will doubt. But, Mr. President, I take issue with those gentlemen, and for this reason: If I understand the Berkeley form of charter, as explained by the Mayor of that city, it gives the council the right to appoint the Commissions, and those Commissions are responsible for their acts to the Council, and that the terms of their office depends upon the Council. If I understand it, the whole object of the Commission plan of government is, to take the affairs of the city out of politics. Now, we can readily see that the Council, in the appointment of these commissioners for the purpose of doing the business of the city, has the greatest opportunity of perpetuating themselves in office that any men could possibly devise.

MR. DODSON. The gentleman bases his argument on the wrong foundation. There are no commissioners appointed. The Councilmen themselves are the commissioners. I interrupt him so that he may get the foundation of the matter straight.

MR. BUTCHER. The Berkeley plan, however, if I am correctly informed, is that the Councilmen appoint these Commissions. Am I mistaken in that Mayor Hodghead?

MAYOR HODGHEAD. We have no Commissions in Berkeley, except those that serve without salary, like the Playground Commission and the Park Commission. You probably refer to the officers?

MR. BUTCHER. Yes, to the officers. If a given City Council want to remain in office, its members will say to those gentlemen, their appointees, "If you want to keep your office, you get out and hustle for my election; get me all the votes that you can, and if I am elected, I will keep you in office." I would say that is the greatest political scheme going. Let me ask you how long you have been working under this plan?

MAYOR HODGHEAD. Sixteen months.

MR. BUTCHER. You have no election, then?

MAYOR Hodghead. Yes, we had one, the first election.

MR. BUTCHER. Have you had an election in San Diego since you started?

MR. DODSON. No.

MR. BUTCHER. And they have had none in Berkeley. So in neither city can they know it will work out from experience. I am ready to admit that if you elect good men for Councilmen, that do not want to do politics, all well and good—it is a very fine thing. But there is that “if” which has been brought into the world and been with us ever since the beginning—*if* you can only get good men. The sole object of all city governments, after you simmer it all down, is to get good men in office and keep good men in office. But if you should happen, under this plan, to get a bad man in office, or a bad set of Councilmen, they will appoint men who will do their bidding in politics, and will perpetuate themselves in office. But they tell you there is the referendum and the recall. But how can you recall a man if he has appointees enough to defeat his recall? How are you going to get him out of office? I believe that the government that we have had, the combined experience of mankind throughout the ages, the natural product of that experience is a better and safer thing to rely upon than any untried, new-fangled arrangement that might possibly work well, and yet which is not likely to do so. Government is the outgrowth of the experience of people. I fully agree with my friends, and especially with the Mayor of Berkeley, in regard to the manner of election—that plan is an excellent one. He is right in that. But as to the rest of it, after you get the men in office, and then to let them go to running the city by appointing the other officials, is a thing which results in keeping the city in the grasp, as it were of a few men, and I am opposed to it.

MR. DODSON. In the first place, Mr. President, I believe Mr. Butcher will agree with me that the people are in control. If this is a proper mode of election, then we can depend upon the people to express their will in that election. If they do their duty, they will select good men, and if they select good men, they will get a good government. You can have good government under a bad charter, I admit, and I admit also that, under the old form of charter, you can elect good men. But you cannot always do so—at least that has been our experience. Take this recent election with us, and speaking of the government being in politics, I am at the head of the Sewer and Fire Departments. I told the chief that they would have nothing to do with politics, they would go and vote as citizens, but not in any way identify themselves with politics. One of the firemen went to the Chief and said, “Who shall I vote for?” and the Chief said to him, “That’s your business, not mine.” One of my friends wanted me to go around and be introduced to the firemen, and I said, “No, sir. We are not in politics.” That is the policy of the Commission form of government to get the thing out of politics and let the people say, and if they elect good officers, they make good appointments, and when they make good appointments, they break down the powerful men that we have to contend with in the past.

MR. BUTCHER. That is all right so long as we have the right Mayor, and have the right men appointed. But suppose we get the wrong man in office?

MR. DODSON. Leave it to the people—they are responsible.

MAYOR HODGHEAD. I am very glad, indeed, that Mr. Dodson and myself have been able to say something here that is worthy of discussion. We seem to have “riled” Mr. Butcher a little bit, and that contributes a great deal to the convention. I agree with a great deal that Mr. Butcher has said, and I agree with almost everything except that the Commission form of government is a freak. The argument that has been produced would probably come with some degree of force, if it had been made ten years ago, before this plan had been thoroughly tried. But Mr. Butcher is traveling about that length of time behind the proceedings. We have to allow something for history. This plan has been in operation for about ten

years in some of the cities, and it has been in operation for several years in about sixty or seventy of the cities of the United States, and in no city where he has ever been tried have the disastrous consequences which are here prophesied for it ever resulted. I don't know exactly what sort of a system Mr. Butcher operates under, or what kind of a political system they have there. He evidently displays some unfamiliarity with the Commission form. Taking his argument, I would reply that, while the Council is bargaining with the office holders and saying "If you will go out and keep me in office, I will enter into a solid compact that I will keep you in office," the people came along and put them both out.

In the argument that had been advanced here, Mr. Butcher has entirely overlooked the most important factor in all government, and that is the voice of the people, and that is the Commission government in its essence—it is the voice of the people. Of course, there is a danger there, I realize that, and that has been the most important subject, it is, indeed, the test of the whole of the Commission plan of government, this power of appointment. But down in Galveston, when great necessity came upon them, the necessity of doing something, they said, "The only way to run this government is to get away from the old form of government"—the very condition which Mr. Butcher so graphically described here, of this constant bargaining between officials of the city. It is the very thing, this bargaining for office, which the cities of the United States are struggling now to get away from, and so far as they have gotten away from it, it has been by getting politics out of municipal elections. There is a danger there, as Mr. Butcher says, if your men elected to office want to use it. But the fact is, the people won't let you use it, and that is the reason they have put in these remedies of the referendum and the recall, to meet that very contingency. And in not a single instance has it ever been used as Mr. Butcher fears, and it won't be used here in San Diego, because it is political death to any man to use it. While there is the danger there, you would very much cripple the efficiency of the Commission form of government, unless you give this identical power to the Commission and make the Commission responsible. And we are willing to incur and encounter that danger in order to make the Commission government firm and efficient. You cannot pursue a constant policy in any form of administration, unless you give that power to one set of men. That is the only way in which you will ever make a success out of any form of government—the give the people the power to correct it, and there will be no policy for trading such as is here discussed.

MR. HYDE of Palo Alto. In our little city of about five thousand inhabitants, we have a new charter, operating under a modified Commission form of government, for the same length of time that Berkeley has. The difference between our charter and Berkeley's are too many for me to go into an explanation of on the floor here. I simply want to say that the Commission form of government in Palo Alto has resulted in putting our government on a business basis for the first time in the history of the town, and, at the end of the first fiscal year under the charter, we have the only complete business report of the condition of the business of the city that has ever been made, and it has worked for economy, and we have had more efficient service for less money than we have ever had before, and at the same time we have been able to reduce our tax rate. So with us it has worked out very well, indeed.

MR. BUTCHER. How many Councilmen have you?

MR. HYDE. We only have fifteen.

THE PRESIDENT. Is there any further discussion upon the subject?

MR. BUTCHER. I don't want to be misunderstood in this matter, Mr.



President. There are many good things to be said for the Commission form of government, but I can't see that in the end it can be otherwise, if the matter is pursued, than that these evils will result. So far as the recall is concerned, you must remember that these same men can prevent the people from recalling the Councilmen, since the Councilmen can in the recall election use the influence of those appointed by him, so that altogether a Board can perpetuate itself in office—re-elect itself as often as it sees fit.

MAYOR CONARD. Mr. Butcher inquired as to whether there had been an election in San Diego. There was an election in San Diego, and for the first time in twenty years, the Fire Department and the Police Department were not actively engaged in politics. Under the old scheme of things, we started our charter amendments, and we succeeded, under the direct primary, notwithstanding that the Police and Fire Department did politics—we succeeded in beating the politicians two to one. So it seems to me there is absolutely no danger in the particular point in the argument made against the Commission form of government.

MR. WRIGHT, of Santa Cruz. The gentleman from Palo Alto stated a moment ago that the result of the Commission plan of government in that city had been a reduction of the tax rate. The city of Santa Cruz has now under consideration a new charter. It is a matter of importance that we know why or in what manner this should result or have resulted in this saving to the taxpayers. The city of Santa Cruz has also reduced its tax rate within the last year, and it might be something the same cause that has reduced the Palo Alto tax rate. If so, it could not be credited to any form of government or administration. With us, our bonds have been finally paid, and there is no need for a tax for that as there has been heretofore. I would like to know in what manner this reduced rate of taxation came about. If we can get the benefit of it, I think we are entitled to that, so as to be prepared to report to our city.

MR. HYDE. I don't know that I can give you a reason that would be entirely satisfactory. But we did a thing that has never been done in our city before, we got the Ways and Means Committee of our Council to prepare a full, carefully worked out, detailed budget of expenses that we thought would be necessary for the coming year. We assigned a certain amount of money to each commission. They came to us in the first place with their requirements, and each of them said, "We want so much money, for such and such purposes". I happened to be on that committee myself, and we took the reports of the different commissions as to what they wanted, and we took them up, and we found it was going to be a great deal more money than we could give them. Then we went to work and took a representative of each commission and said, "What can you get along without?" And we cut out unnecessary things, and carved it down to a certain point where we made a reduction, I think it was, of 27 cents, in our tax rate last year, and we had a more efficient service with that very careful apportionment of the money in advance, than we had had under the old system of letting everybody get everything he could. In other words, we found it a good thing to plan in advance. As the Japanese said in their late war, a certain thing was done "as pre-arranged".

MR. WRIGHT. Could not that have been accomplished under the old charter just as well, if you had had the same type of men in there? I take it you elect your commissioners from among the same men and by the same voters as you would your councilmen. We have a new charter, and it needs some remodeling, we have no doubt, but we have a provision that requires this budget to be made up, and the Council apportion out as much money as they think they can raise. Of course, if the Council should decide to cut down the expenses, or eliminate some of

their requirements, some things they think they ought not to have, it seems to me that they could do it and accomplish the same result; whether under the Commission form of government or the old plan of government. Without taking issue one way or the other, I desire this as a matter of information. I want to know where we stand, and what we are liable to go up against if we adopt the new form of Commission government.

THE PRESIDENT. The size of the tax rate depends a good deal upon what you want to accomplish in your city, of course.

MR. D. REED, of Whittier: Taxes are always low in a dead town, where there is nothing doing. Your taxes are governed by the amount of work you do and the amount that you want to pay for. Any system of government under efficient officers is a success. To my mind, the Commission plan, properly worked out, will be the greatest success of all. But, when you come to speak about taxes, the taxes are higher or lower according to the amount of improvements your city is carrying on—that is, when your money is judiciously expended. I don't believe the city authorities can either increase or lower taxes any more than they can either stop or carry on more or less improvements.

MR. W. SIMPSON, of San Jose. Just a question, Mr. President. Would not the placing of the employees of your city government on a civil service basis do away with the objection of our friend here, or of any person, under either form of government?

THE PRESIDENT. I don't know. You will have to go down and ask the Los Angeles people about that.

MR. DODSON. I want to say one word more. What is everybody's business is nobody's business. Under the old form of government, too much is left to haphazard. There is not enough interest taken. I am a believer that a good government can be had under a poor charter, but it can be had a great deal better under a good charter. Officers have been frequently hampered by the restrictions of a charter that remained for a different class of men. If you can have a charter that gives men sufficient latitude and then hold them responsible, you can expect good government from them, and the people know where to place the responsibility, and the people are also responsible for their election.

THE PRESIDENT. Gentlemen, we will now hear from Mr. de Mattos, of Bellingham, Washington, who has now got his breath. (Applause)

MAYOR J. P. DE MATTOS, of Bellingham, Wash. Mr. President and Gentlemen: Public speaking is not my long suit, but vetoing is. The point that these gentlemen who are advocates of the Commission form of government make, I cannot agree with, because, under the old system, as a rule cities place in the position of chief executive a man who makes a study of these problems more than do the councilmen. I have been Mayor for six terms, and my long suit has always been vetoing the acts of the councilmen. I veto a few more every year, and four-fifths of my vetoes are unanimously sustained. In fact, they are very rarely overridden, except in a case of some corporation desiring more than it is entitled to and the Common Council are worked upon through corporate influence, just as the men whom you send to the legislature are worked upon by professional lobbyists. According to my theory and idea, this divided responsibility does not work, as it is in the Commission form of government. If in it they do not propose to leave the veto power to the Mayor, the presiding officer of the Commission, I think it is a serious mistake in their form. I will agree with the gentleman who has said that it is the man and not the form of government—it is the man behind the gun and not the gun itself that is the important thing. (Applause)

Now, gentlemen, in a city on Puget Sound that claims over a hundred thousand, (but the director of the census takes some issue with it,) the city of Tacoma, they have tried the Commission plan, and the same men who were getting from \$900 to \$1200 a year and doing comparatively satisfactory work as such officials, were elected under the Commission plan to positions giving them \$3600 a year. Now, I know that under the salary which I now receive, I am giving just as faithful and efficient service to the city, at least I feel so myself, as I did when I was not receiving any. In fact, I cannot give them any more satisfactory service than I have. In Tacoma, under the first three months of their administration, there were expenditures of over \$130,000 more under the commission form than under the corresponding three months of the year preceding, under the old plan. It seems to me that is an object lesson. I thank you. (Applause)

MR. CRAIG. Of course, we are all endeavoring to arrive at a model system of government. I am one of those who favor the Commission form. The city that I have the honor to represent is one of the sixth class, and there are five trustees, and the trustees select from among themselves the presiding officer. What I would like, if possible, to obtain from the Mayors of some of these larger cities, is, why the officer called a mayor should be an elected officer; why not, while we are about it, elect all as councilmen or commissioners or both, and let those five commissioners elect their own presiding officer? Possibly in time to come one of these gentlemen, who knows a whole lot of the executive business of some municipality, will take the bit in his teeth, as they have done in San Francisco before now, and he will be the whole shooting-match. It seems to me it would make the matter much simpler, and leave the authority in the hands of the people more directly, if, instead of electing one man and naming him the presiding officer of the Board, the people should elect five on an equal basis, and let the Board select their own presiding officer. Fancy, if you please, a large corporation, a railroad corporation, electing a Board of Directors, and in addition to that place in the hands of the stockholders the power to elect a chairman of the Board of Directors or Trustees. The stockholders become dissatisfied with some of his government, and the rest of the Board of Directors have no power but to refer that back to have him recalled by the stockholders who gave him that position. I think the matter would be much simplified if the five were elected upon an equal basis, I say, and those five selected their own chairman, and, when it arose that they wanted to change the presiding officer, it would be in the hands of those five to declare the office of chairman vacant, and select another man in his place. I would like to hear from some of the gentlemen who hold the responsible position of Mayor why that would not answer as well, to have the five commissioners elected upon the basis, say, of cities of the sixth class, and have them do that.

THE PRESIDENT. One of the great advantages that I see in the theory of the Commission form of government, as we have somewhat of a modified form of that in our town, is that formerly city and county officials were always making bargains back and forth, "You help me to get this city office this time, and I will help you in the next county election to get that county place". It is the elimination of the party convention, to my mind, which has brought us good results, and one of the strongest points there is, that they cannot make these combinations, and therefore you get a set of efficient city officials. We have had no party convention in our city for thirteen or fourteen years. We had none for a number of years before the adoption of the charter under which we are working.

MR. HODGHEAD. Mr. Craig asked a question. The plan as suggested by Mr. Craig has been adopted in a number of Commission cities, and it works with



fair success. They elect councilmen, and those councilmen select their own presiding officer. In response to the interesting talk of the Mayor of Bellingham Washington, it would seem a great pity to take away from him the veto power, which he exercises so efficiently. It seems that the council, after having the error of its ways pointed out to them by the Mayor, practically always follow his suggestion. It is perfectly apparent, therefore, that if the Mayor, with his superior information, would sit with the Council and advise with them in the first place, that these erroneous acts would never have been passed. And that is the Commission form of government. As this is a sort of experience meeting, I was going to relieve Mr. Butcher a little further of his fears, but I see he has become discouraged and retired from the convention. I want to say that I have been making a little study of the Commission form of government, not to judge by it all, but to try to find out if it is the proper method, and if it is wrong, to discard it, and I had a talk with some of our officials who had the misfortune to be appointed by the present Berkeley Council and who are, in a sense, dependent upon it. One of our officials that I have in mind particularly is a very superior officer, and he knows his position is very secure, and that the Council would not discharge him, and that no other Council would discharge him. I thought that gave me an opportunity to talk over with him this very subject that Mr. Butcher thinks is a subject of such great danger, I got a great deal of information from him, and he was perfectly free to talk, because he knew he would not harm himself any by doing so. He said he had been in office a number of years, and had been elected a number of times to his position, and he said that the officers of Berkeley who have held their positions as appointive officers have been compelled to go into politics to solicit for the nomination and support and election of the members of the Council in order to keep their positions; and he added that he was himself very well satisfied indeed to come under this system, because it relieved them of any expenditure of political energy whatever, and the officers felt that they were entirely secure in their positions. As I stated in my paper, he also said to me, that the tenure of office depended entirely upon the quality of service, and they felt more secure than if they had to go through with an election first. I think that is the general experience. The fact is that any good Council can get along without any danger at all—I believe with everything that has been said here. You can fix a reasonable tax rate, and leave all the rest of it to them. But the main object of the Commission form of government is to get that particular type of man in office.

MR. T. W. DRULLARD, Mayor of Santa Cruz. Mr. President, I have taken great interest in the papers that have just been read, and in the discussion upon them. I do not wish to intimate that I am in any way opposed to the Commission form of government, but I think there is one fact that the gentleman has so far failed to explain, and that is how a Commission form of government is going to improve men or elected officers morally. It seems to me to resolve itself finally wholly into a moral issue or a moral question. To be sure, the direct primary may give a guaranty of better selection. But why would not that rule apply just as well under the old charters now existing as under a Commission plan? I cannot understand how this plan can possibly improve men morally. As has been stated and represented, any government is honest and efficient under honest and capable men. Does the fact that a city is operating under the Commission plan guarantee more morality, or a higher degree of intelligence than is now existing? I cannot see, for my part, how there is any improvement guaranteed under the Commission plan that may not be had under the existing plan, under which the most of us are now working. It appears that it is wholly a matter of careful election and that the peo-

ple are wholly responsible. To be sure, under this plan, you may induce more interest in the matter of election, but I can't see how. If the taxpayers and citizens are not all interested in municipal affairs, I can't understand how the form of government is going to increase their interest. That is one argument that I would like to have the gentleman advocating the Commission plan explain. I am here, as my friend Major Wright has stated, for information, and particularly concerning the Commission plan, of which we have heard so much—we would like to go back with some definite knowledge, and if it is as good as represented, we want to go back with certain facts and arguments that we can use in its advocacy. But we want to do it upon proper information.

MR. C. N. KIRKBRIDE, City Attorney of San Mateo. I think, Mr. President, in order to understand the reasons of the efficiency form of government, a person should go and study the success of it in the State of Texas. You will remember that in the cities in Texas which first adopted this plan there, they did not have an initiative or referendum or recall. The only particular change they made in the old plan there was in cutting down the number of councilmen, electing them at large, and then giving them this big control of the affairs of the city; in other words, instead of calling them councilmen, calling them commissioners, and placing them in charge of a particular department of the municipal government. Thereby the particular councilman would have actual control of the management, we will say, of streets, and he would have his office and would devote practically all of his time to running the Street Department, and he would get his reports from those under him, and control the department. Of course, when it came to the appointment of the more important officials, we will say, in that department, the appointment would come up before the general council. But he would be practically in control of that body. Another member of the council would be in control of the Police and Fire Departments, and another man in control of the finances. Thereby each man would have, as you see, the whip-hand in his department. For instance, supposing a question came up concerning the management of a street. The man would not have to go to the Mayor, and he would not have to go to any other councilman about that; he would settle it instantaneously by making his order and thereby and then obtain efficiency. I have seen men of the highest capacity go upon a municipal board, men who could handle and have handled successfully some of the largest corporations up around San Francisco, and, in my judgment, make a failure of it, for the simple reason, as I look back upon it now, that they did not have the control. The party would go into the Council, and the matter would be presented by application, or something of that sort, and, instead of getting their judgment, it would be referred to a committee, and would be held in suspension for a week or so, with no one paying any particular attention to it, and at the next meeting would perhaps be forgotten about, and ultimately when taking up the matter for decision, a decision would be made on the spur of the moment, perhaps, and without mature thought. Whereas, if either one of these men had the authority or the duty and responsibility of doing it, deciding the question, he could decide it justly. I have an instance which has occurred to me within the past two years in the county. We have a very successful supervisor in our county government who has made a wonderful success of roads, who has made the best roads in the county. His road overseer is a certain man, and I have been surprised to see how that particular man, knowing his training, knowing his capacity, knowing his original education, could make such a success of road construction. His brother, one of the municipal council, a man of equal capacity and equal education, the same origin, if I may so term it, and one who, we would assume, would make a success of road

construction. He was put in charge of a street department in the municipal council, and succeeded in showing no indications of any peculiar success in the construction of roads, and the street committee was a failure, so far as an efficient method of government was concerned. Now, there were two men, one man had control, he discharged the men and hired the men and got good work; the other man would report back when a thing was referred to him at a subsequent meeting of the council, perhaps he would investigate it and perhaps he would not. He just did not have the power to act, and therefore did not act, whereas he would have acted if the situation had been different. Now, the statement is made that in the Texas form of government they have in many of the cities the same officials as they had under the old form of government. Under the old form, they did not make a striking success of it, while under the new, it seems that they make uniform success. Now, take Des Moines. In Des Moines the labor unions and labor organizations voted against a Commission form of government, and yet when the Commission form carried, it so happened that those opposed to the Commission form of government were elected. The labor ticket was successful. What was the result? Those men went in opposed to the Commission form of government, and yet as it turned out, made a remarkable success of it. It was due to the fact that by this method responsibility was thrust upon them. They were given the power, and they arose to the emergency. (Great applause)

After certain announcements by the President as to the plans and program of the convention, an adjournment was taken until the following morning.

THE PRESIDENT. We will now have the pleasure of listening to an address, illustrated by stereopticon views, by J. H. Reed, Tree Warden of Riverside, on the subject of Street Trees:

MR. REED. I am glad to have the opportunity of presenting a matter before this body of men who for the time being have in charge the civil and physical well being of the rapidly growing cities of our great State, a matter which I think is very generally and very grievously neglected—the beautification of our public streets. You are spending large amounts in building roadways, and successfully too. I doubt, if at any time, in any place better streets have been or are being made, than right here in some of our California cities. They serve the purpose of travel-ways admirably, but, except possibly to the eye of the civil engineer and the road builder, there is not much beauty in Macadam road-beds, when lined only with cement curbing and sidewalks, however well they may be made. More and more people are demanding that beauty, as well as utility, be conserved on our public streets as well as on private home grounds.

When a man builds a fine residence on large grounds or a small bungalow on a city lot, he at once sets about beautifying the premises. It is just as desirable that a city, as a unit, when it has built good roadways, should at once begin to beautify them. A street, however well-made its road-bed and sidewalks may be, without suitable ornamentation, is as uninviting as a fine mansion set in large, bare grounds or a cottage with a bare dirt frontage.

#### VALUE OF STREET TREES

The principal means of beautifying public streets throughout the world is by tree planting. There is nothing that relieves the monotony and ugliness of bare streets so quickly and thoroughly as properly chosen, well cared for trees, nothing that adds so much to their beauty. The added every day satisfaction that streets



lined with trees give to the residents of any city pays all the cost of the trees, many times over. But they have another value that will appeal to some who may not care for the esthetic point of view. Street tree planting has high commercial value to any city. Other things being equal, the city that has made itself, or is making itself, most attractive as a place of residence, is to secure the largest portion of the thousands of the well-to-do, desirable people, seeking homes in California every year, and in constantly increasing numbers. We must not forget that many of the families, most desirable as additions to our population, come from tree lined villages and towns of New England and the Middle States, and the dull, naked streets of our towns repel rather than attract.

Riding with one of our conservative merchants the other day, I called his attention to a row of trees along two continuous blocks and asked for what amount of cash in hand the City could afford to have those trees dug out, restoring the street to the condition it was in three years ago when the trees were planted? "Not for a thousand dollars", was the prompt reply. Those trees have cost the City, including planting and care, less than fifty dollars. Since we commenced our systematic work in Riverside, we have planted what is equivalent to over 500 such blocks.

I found two things in the East that give some idea of the value placed on street trees there. In most of their Cities, when a tree is killed or badly damaged by gas from a defective pipe, or other like cause, the damage is assessed to the companies by the Courts, and I have found no instance where it had been placed lower than \$30.00 per tree, and usually it is from \$50.00 to \$100.00. The other thing was the expensive apparatus owned by some cities for moving grown trees to fill vacancies in rows of old trees, the moving costing from \$40.00 to \$100.00 each.

Being shown over what is considered one of the most beautiful cities in California recently by one of its prominent business men, after going over some of the early, well planted, beautiful streets, over which all visitors are taken, I said, now let us go over some of your average streets. We found that the partially planted and wholly bare streets covered very much the larger portion of the city. I said to my friend, "Supposing these streets had been planted when the others were, and had been as well cared for, what effect would it have had on the City's valuation today?" "Fifty per cent", he replied.

I consider ten to twenty dollars each a very low value for every suitable tree on a public street, properly placed and cared for, when it is two years old, as a purely revenue producing asset to any residence City.

I have dwelt on this matter of economic value of street trees, because I believe that, if it were better appreciated, it would lead to greatly increased, systematic planting in our California Cities. But after all, the purely esthetic value of street beautification to an intelligent community, is really much greater than the economic.

### MUNICIPAL CONTROL

Now, if I am right in these premises, how to secure the best results in the quickest and most economical manner is the important consideration.

After five years of somewhat comprehensive study of matter in a large number of cities, and the same length of time in actual experience in my own town,

both before and after it was secured, I am absolutely convinced that the only way street tree planting and care can be satisfactorily carried on in our cities, is under Municipal Control. I believe the reason why the large majority of the residence streets in most of our California cities to-day are either bare or unsatisfactorily planted is because this efficient method of securing general and proper planting has but recently attracted serious attention.

In most cities there are people with more or less cultured tastes and means to gratify them. They not only build artistic homes and beautify the grounds around them, but extend their improvements by beautifying the adjoining street margins. Others of like tastes make their homes near by, hence we find in many places the street margin of entire blocks—sometimes of whole neighborhoods, beautifully improved. The attractiveness of these special spots, though but a small fraction of the whole, is sufficient sometimes to give the city itself the reputation of being beautiful, because these certain streets are the only parts usually visited, while really the main portions of the cities are anything but beautiful.

Those of you who have observed our California cities generally, as to their beautification, will, I think, recognize this as the condition of most of them—a few streets well planted and cared for, but much the larger portion either entirely unplanted or planted here and there to miscellaneous and often unsatisfactory varieties, indifferently cared for.

This condition is the inevitable result of leaving the tree planting and care in part or wholly to adjoining property owners or occupants, and without any good reason. The parking space belongs to the city the same as that portion of the street occupied by the sidewalk and *the trees on it should be controlled the same as is the sidewalk.* In fact it is *more important* that they should be, as they are or should be a permanency. *If the sidewalk is wrong, it is easily and quickly replaced, while if the wrong tree is planted, it must be endured indefinitely or removed and wait years for another to grow.*

It is recognized, of course, that the individual interest of any given property owner in the pavement or street trees immediately in front of his premises, is greater than that of any other individual, but the *general* interest in that bit of sidewalk and the trees bordering it, is much greater than an individual interest, *and this general interest can only be conserved by City Control.*

A city can not afford to have a whole block or an entire street disfigured because certain property owners insist on having no trees on their frontages or some variety quite unsuited for the purpose. Especially is this true in view of the fact that property owners are constantly changing locations, while the City's interest in the street is permanent.

In the case of pavement, the wishes of the bordering property owners are consulted as to kind etc., and their wishes are complied with as far as the best interests of the street, present and future, will allow. So their wishes as to variety of trees and their management should be consulted, but not to the extent of allowing each to plant what he pleases or none at all, as he sees fit. This is as disastrous to the beauty of a street, as to have the sidewalk in patches, a part cement, a part gravel, and the balance of plain mother earth. Yet this is just what you see on the majority of streets where trees are planted at all.

MUNICIPAL CONTROL CORRECTS ALL OF THIS. It first sets about

getting the streets planted, not some special streets, but in all sections of the City, as much along the streets bordered by laborers' cottages, as along the tourist drives or in the show sections of the City, with view of making the City Beautiful in its entirety, for the benefit of its own people first, and for the admiration of visitors next.

### FIRST STEPS

After a definite plan is decided on, the first steps towards systematic street tree planting should be to decide on the most desirable varieties, under the various conditions on different streets, and here is one of the most important advantages of City Control. In selecting trees for the street, there are several essential things to be considered. The street is not the proper place for experimenting. We should be sure of what we are planting.

First. The street tree should be long lived. It should serve for generations.

Street trees should be suited to their purpose. Their habit of growth must be adapted to street conditions. Some trees are beautiful when young, but quite unsatisfactory on the street after a few years.

The street tree should be hardy under severe conditions. Some trees that do well in the open park or yard will not flourish under the less favorable conditions of paved streets.

Tall, wide spreading trees should not be planted where they will obstruct desired views, or where sunlight and not shade is desired. I remember visiting a friend in this City some years ago who had built a beautiful home. Remarking on the absence of trees on the premises, he said "We don't want trees, we want to see the ocean." Now trees are not necessarily obstructionists. Where shade is not desired, there are other ornamental trees that may be used with good effect without obstructing desired views. I confess that, to me, the vista through rifts of tree tops to ocean or mountains is more pleasing than a broad, uninterrupted expanse.

Now, to make selections of varieties to suit all these conditions, requires experience, good judgment and trained knowledge of trees, not to be found with the average owner of adjacent properties.

### PLANTING AND CARE

Suitable varieties being chosen, then comes planting. Very few City people know how to plant a tree. Wealthy families who employ gardeners or who secure experts for the purpose, can have this done properly, but we know that these are the exceptions. From my somewhat extended observation, from one-fourth to one-half of the trees planted by the ordinary property owner either die outright or make a sickly growth which is worse, because it usually retains an unsatisfactory tree in place of a possible vigorous one. As few know how to care for trees as how to plant, if they had time and inclination to do it. To secure satisfactory results, the early irrigation and cultivation should at least be directed by an expert.

### PRUNING

Again the beauty of a mature tree, especially of the fast growing varieties used in Southern California, depends very largely on intelligent shaping and



pruning when young. Formerly, in Riverside, each resident cut the trees on his street frontage to suit himself. Such trees as were not so attended to, when they got in the way of passers on the sidewalk or road-way, the Street Superintendent sent his road-making crew to do the pruning, and as might be expected, sorry work they made of it.

We all have occasion to know that the tastes of residents are not always safe to direct the pruning on the public streets. So long as this privilege is allowed, the best planted streets are liable to be permanently disfigured by some freak notion of a single lot owner.

In Riverside, no pruning is allowed except by permission from the Tree Warden. This causes no friction because it is always granted where it is known that it will be properly done.

Mutilating street trees by telephone and electric wire lines is difficult to prevent under individual control. When our city took the care of its trees, many of the finest rows were in bad condition from cutting by linemen. We now have little trouble from this source. The Superintendents of the different companies work cheerfully and heartily with the Tree Warden to save the trees from being disfigured. All cutting is done under the Tree Warden's supervision.

Many thousands of dollars have been spent by different companies, in putting in higher poles, and in other ways, to protect our street trees from damage. Where poles are put in that will give the trees fifty feet clearance, the City obligates itself to keep the wires free. The question frequently comes to me, "How can we protect our street trees from damage from wire lines?" The problem is solved by judicious management under City control.

Municipal control of street trees is being rapidly adopted by the more ambitious towns all over the country. Five years ago when Riverside first took up the matter, to learn how street trees were managed in older communities, I visited a large number of cities in the East that had reputations for beauty. I found less than a score in the entire country with absolute control of their trees. These were the most beautiful in the land. Washington is doubtless the most beautiful city in America, if not in the world. Others may have more striking features, none are so beautiful as a whole. This is owing—thanks to George Washington's farsightedness—to the fact that the government has had entire control of the street ornamentation from the first.

Last summer I made another trip throughout the East, studying parks and street trees in over thirty cities. I found a large number of towns had already adopted City control of their trees and street tree planting and systematic care were going on as never before. Newark, N. J., had planted over 30,000 trees during four years and over twenty cities in that State had joined that city in adopting the new plan. I found such towns as Cleveland, Ohio, and Buffalo, N. Y., had taken charge of their street beautification, had established municipal nurseries and were carrying on street planting most vigorously.

Riverside was the first town in the west to adopt the plan. Redlands, Pasadena, Ontario and Corona have recently joined us and some five or six other California Cities are now considering the adoption of the plan. Had we known at first what we had to learn by experience, we could have done the work more wisely, efficiently and speedily. But we have accomplished something. We have planted over 10,000 trees on our streets since we commenced. We have but few streets unplanted. The earlier of these plantings have already absolutely changed the general appearance of whole sections of the City. It is simply wonderful how quickly a row of our fast growing trees, uniformly planted and intelligently cared for will beautify a street. Four years will accomplish as much as eight or ten with their shorter seasons and slower growing trees in the East.

When we commenced planting under the new system, there were some 30,000 mostly old trees on our streets. The change made on these old trees by systematic management has been as important to Riverside as the new plantings.

But we have a vast deal to do yet. Sometimes complimentary things are said of our street ornamentation, but I never hear them without a twinge. It is yet so far from what it should and may be. It should be remembered that Riverside is yet but a town of some twelve or fifteen thousand, though covering some forty square miles, with over two hundred miles of streets to be beautified. Had we the thirty or forty thousand people, our tree planting is now helping to bring us rapidly, the task would be much easier. But I insist that it is at this early stage of growth that our cities should systematically plant trees and continue to plant as new streets are laid out, not waiting for expensive improvements.

I have said that the only way to have this work done satisfactorily is for the City to do it. Ordinarily this cannot be brought about directly. A public sentiment must be behind it. Intelligent individuals must start the matter through some sort of local organization to demonstrate the efficiency of systematic effort. We interested our Chamber of Commerce first. The work of its tree planting committee soon induced the City authorities to take it up. It had developed a public sentiment that heartily sustained the new department. Improvement societies, women's clubs, tree planting associations, will accomplish much in the way of preliminary work. But such organizations are necessarily more or less short lived, since their efficiency usually depends on the enthusiasm of a few leading spirits, necessarily of limited duration. *Hence the main purpose of such efforts should be to lead the way to municipal control.*

My last word is, I believe, that from either the commercial or esthetic standpoint, there is no feature of betterment of the Cities you represent, and whose interests you have at heart and largely in hand, more worthy of your sincere attention, than the proper, permanent and general beautification of their streets. (applause.)

(To be continued)



## DEPARTMENT OF CITY ATTORNEYS

### THE IDEAL CITY CHARTER

BY FREDERICK BAKER

The ideal City Charter is the charter which best conserves human life.

It is the one which develops the highest type of citizenship and best promotes the cause of civic righteousness.

It should be simple in form, prompt in action, efficient in result and economical in administration.

Above all, it should encourage an active public interest in public affairs and be quickly responsive to an intelligent public opinion.

This problem of City government is one of growing importance.

The census of 1790 showed only thirteen cities with more than 5000 population and none with more than 40,000.

In 1880 there were 495 cities in the United States exceeding 5000 population, 40 exceeding 40,000 and twenty exceeding 100,000.

In 1900 there were 160 cities in the United States of 25,000 population and over, and the census of 1910 will show there are 220 such cities. In 1900 about one-third population of U. S. lived in cities of 8000 and over.

The census of 1910 will also show that the drift of population from the country to the city is continuing at an increasing ratio.

The success or failure, therefore, of American institutions is dependent upon the success or failure of the government of American cities.

The one great authority in our modern political institutions is Bryce's American Commonwealth, first published in 1888.

It speaks of city government as "the admittedly weak point of the country" and says, "What Dante said of his city may be said of the cities of America; they are like the sick man who cannot find rest upon his bed, but seeks to ease his pain by turning from side to side."

When Mr. Bryce made his investigations the old methods of city government generally prevailed.

There was a separation of the executive and legislative functions and the city charter was modeled largely after the federal system of government, with an elaborate system of checks and limitations.

Mr. Bryce clearly shows that this system is a failure when applied to the problem of an efficient administration of municipal business.

It was not however, to the old world models of City Government that we finally had to go for a solution of our problem, but rather by undergoing sort of an evolutionary process ourselves that light began to dawn on the municipal horizon.

When in 1900 Galveston, Texas, was wrecked by a flood the citizens found that the chief obstacle in re-building the city was its city government.

I quote from a pamphlet entitled "The Commission Form of Government", compiled by the Kansas City Star in answer to a large number of inquiries on the subject of commission government:

"Galveston found that the old system of municipal rule composed of a Mayor and a number of Ward Aldermen, to form any specific duty, with the city "divided against itself" into representative districts and each district controlled by selfish interests to oppose every other district; with no authority on the part of any one to do anything, was an effective barrier to the great work of city building.

So Galveston appealed to the Legislature for the Commission at the hands of the state to direct its affairs pending the rebuilding of the city. After persistent effort it secured such a board and the members were called Commission rule. That is why the new rule is commonly called the Galveston Plan or Commission Government".

The commission system at Galveston marked the transition from the old form of political organization of municipal government to that of modern business enterprise.

Under the commission form the people constitute the stockholders, are the board of directors.

And at this point it may well be asked, that if the old system of political organization of City government has proved a failure, and, on the other hand, if the form of organization of the private corporation with its board of directors has proved a wonderful success in the modern business world, then why not displace the unsuccessful method and substitute the successful one?

After all City government is, or should be, a matter of business rather than of politics.

There was, however, still another step to be taken before this plan would recommend itself to democratic America. I read from an article by Charles Edward Russell in Everybody's Magazine for April, 1910:

"Galveston's experiment in municipal management was bitterly opposed on



the ground that it was undemocratic, which it certainly was. Nevertheless, in the peculiar situation of City affairs its success was great. The five Commissioners seemed to develop the sense of service, a sense quite new in the history of American municipalities. There was assuredly a great decrease of official dishonesty and a great increase in efficiency. The first years operation showed that notable economies had been made; the city had never been so well governed, nor so safe, and had never looked so well. Finally, nearly all observers agreed that the destroying of the old ward lines and the unifying of the City's interest were most wholesome changes. When these results were apparent, the City of Houston adopted Galveston's plans and secured similar benefits.

Still, the plan was undeniably open to the very grave objection that it was essentially reversionary and exposed any City adopting it to the perils that always accompany autocracy, and are greater than any inconveniences arising from ordinary misrule. What was needed in this country was a larger measure of democracy, and this plan actually diminished the people's share in their government, already absurdly small. If the idea of operating a municipality sanely as a business enterprise and strictly on business lines, could be united with the idea of direct responsibility, the new plan would probably be the best ever devised."

It was ex-Senator Pettigrew, of South Dakota, who supplied the missing link by drafting a bill which was adopted by the Legislature of South Dakota, that successfully united the two ideas of business efficiency and a government based on democratic principles.

His bill added on to the Galveston plan provisions for direct legislation through the initiative and the referendum and provided for the recall of faithless officials by popular vote.

It also provided for the direct non-partisan primary for the nomination of all candidates, and ballots without any party designation; thus eliminating the party spirit, the party machine and the party Boss in municipal government. "A consummation devoutly to be wished."

It happened however, that the Senator's own City, Sioux Falls, through the usual combination of "booze", big business and bossism defeated the first attempt to organize under this law, and the City of Des Moines, Iowa, had the honor of first organizing under a similar law, passed by the legislature of Iowa, a City government in which the principles of genuine democracy were united with those of modern business methods in the conduct of its affairs.

It is with a great deal of pleasure that I call attention to the fact that at least two of our most beautiful and progressive California cities, San Diego and Berkeley, have recently adopted this commission form of government.

The Berkeley charter was adopted as a whole and not by amendment of an existing charter as in the case of San Diego, and I therefore, think that the Berkeley charter is the best example of a commission form of government in this State.

The Berkeley charter presents in concrete form the latest results of that evolutionary process that began with the adoption of the Galveston plan.

No doubt, most of you heard the very able and instructive address delivered here last Tuesday by Mayor Hodghead of Berkeley on the Berkeley charter, so I will not discuss it further at this time, except to say that I consider its distinguishing feature of having the first election final as to candidates who receive a clear

majority of all votes cast, a splendid feature to increase interest in the primary election.

In the ten years this new form of City government has been developing it has made wonderful progress and achieved splendid results.

The Editor's note to Russell's article on the subject in Everybody's Magazine for April, 1910, says:

"Here is one splendid victory for the American people—one result of a decade of war for reform. Commission government is becoming a national issue. Already some sixty cities representing over three million people have adopted its essential features. The success of this plan threatens death to organized corruption: Therefore the Beast is showing its teeth and using its customary methods in the legislature. To meet this, the twenty larger cities of Illinois have an organization fighting to wrest an "enabling act" from the lawmakers. A similar organization exists in Michigan. In Texas fifteen cities use the Galveston commission plan. In Kansas nine have the Des Moines plan. Boston, Buffalo, Tacoma, St. Joseph and Memphis—all cities of over one hundred thousand—have adopted commission government. In all one hundred and forty-seven cities want it. Mr. Russell here shows the results in five of the reform municipalities. It is money in your pocket and pride in your heart to know the facts."

In the article following, Mr. Russell summarizes the results, as follows:

1. It abolishes party politics from local affairs.
2. It eliminates the Boss, the grafter and the political machine.
3. It views a municipality as a great business enterprise and provides accordingly for its effective management.
4. It establishes direct responsibility for every public act.
5. It seems to be swift, efficient, economical and adapted to a rational community in the twentieth century.
6. It abolishes a raft of useless offices, sinecures, jobs and political rewards, and substitutes organization, method and work."

In McClure's magazine for May, 1910, George Kibbe Tumes, a writer on the new American City Government says:

"The chief advantages of the Des Moines plan of government are its simplicity the responsibility of its officials, and the complete power of public opinion over them.

Five men, and five only, are elected by a vote of all the citizens every two years. Any voter, poor or rich, can be a candidate before the primaries; only ten names, arranged alphabetically, without party designations, appear on the final ballot.

The five men elected make the City Council, which puts one member at the head of each of the following divisions of the city's business, and responsible for their routine operations:

- The department of Accounts and Finances.
- The Department of Public Safety (Fire and Police)
- The Department of Streets and Public Improvements.
- The Mayor, ex-officio, is head of the Supervisory Department of Public Affairs.

Every important action of this Council is public. Every meeting, attended by

any person outside the Council itself, must be open to every citizen. All business of importance must be done by ordinance, and every ordinance must be filed for public inspection for a specified time before it becomes operative.

If any considerable part of the public is dissatisfied with any action of the Council, a petition of twenty-five percent of the voters—under the right of referendum—will compel them either to rescind it, or to call a special election of the citizens to pass upon it; or a petition with only ten percent of the voters will compel the Council either to reverse its action, or to put it before the voters at the next general election.

The right of Initiative compels the Council to take similar action on new legislation, on the presentation of similar petitions.

The right of Recall compels the calling of a special election to oust any member of the Council at any time on the presentation of a petition bearing twenty-five percent of the voters' names.

#### AN ADVANCE IN CIVILIZATION

Seventy cities\* in the United States have now adopted this new commission form of government; nearly half as many more are agitating its adoption. Each one of these is fighting for something it never had—real democratic government; to escape from the tyranny of combinations formed to exploit it morally and financially. Altogether, this constitutes one of the greatest single democratic movements of recent years.

In all of the cities that have adopted the Commission plan of Government—from Galveston, Texas, down—the great majority of the population strongly favor it. Its negative results, in the elimination of waste and corruption, have been remarkable; its positive results have been no less so. It has proved itself responsive not only to public sentiment generally, but to the better sentiment of the community. It has meant greater prosperity, better health, better morals to the people governed by it. And its general advance across the country marks an advance of our civilization at the point where, in many ways, it has been at its lowest—the modern city.

The ideal City charter therefore, should provide for the Commission form of Government, including direct legislation and the Recall.

It should abolish party politics and partisanship by providing for a non-partisan Direct Primary and a Secondary election, where necessary, without any party designation, on the ballot, to elect by majority vote.

It should provide for the Short Ballot, by having only a few officials elected at the same time.

Lastly, it should recognize the principle that efficiency in administration of City business requires expert knowledge the same as in private business.

Consequently, inducements should be held out by ample pay and fixity of tenure in office, so long as efficient services are rendered, to attract the right class of men to perform public service.

---

\* Eighty-two now claimed.—EDITOR.



## THE EVOLUTION OF CORRUGATED METAL CULVERTS

BY PERRY VAN HORNE

It is probably not generally known, but it is a fact nevertheless, that corrugated metal culverts have been in use in certain localities in the United States for over a quarter of a century.

Originally they were made with cheapness paramount, hence of very light gauge galvanized steel with no pretensions other than that of temporary, or at the best uncertain, longevity. Many of these culverts have long since disintegrated, the result of varying deteriorating elements of the earth in which they were imbedded; others, it is claimed, are still in a fair state of preservation.

Ten years or more ago a commendable tendency was evidenced on the part of various corrugated culvert manufacturers to consider the future. They commenced to operate in the belief that corrugated metal culverts, if made of the right thickness and of a quality of metal superior to galvanized steel, could reasonably be expected to give practical and lasting service. With this in view, the use of extreme light gauge metal which had theretofore prevailed, was discouraged, and increased gauges such as Nos. 18 and 16 for smaller sizes and No. 14 for the largest, were adopted as a fair standard.

Still later experiments were commenced and have continually progressed toward developing a metal on a commercial basis which should surpass steel and equal or excel, from the standpoint of anti-corrosive characteristics, the well-known old-time iron products. That metal meeting these requirements has been perfected is now a matter of common knowledge to the trade.

In recent years calculations based on the adoption of heavy gauges and material of this superior quality, properly galvanized, have been substantially confirmed, with the natural result that corrugated culverts have continued to grow in demand, to undergo improvement and to give satisfaction. Today they are not only recommended by Metallurgical Chemists and specified by Engineers generally, but are also in satisfactory use by the United States Government, various Foreign Governments and under the heaviest traffic-bearing railroads, city streets and country highways everywhere. And they are supplanting in a large degree all other kinds of culverts.

Up to about four years ago the common style of corrugated culverts was cylindrical and riveted. About that time a new and novel idea was evolved in a corrugated culvert made of upper and lower sections with lateral flanges, to be shipped knock-down and nested and set up by the use of bolts. This culvert was also characterized by the embodiment in its manufacture of still heavier gauges of metal than had ever before been used—including for the smaller diameters Nos. 16, 15 and 14 and for the larger sizes Nos. 12 and 10 gauge metal of special anti-corrosive properties, overcoming to a great extent the common criticisms regarding lightness and the effects of corrosion so common to ordinary steel. These better grades of heavier gauge culverts—both the round-riveted and the nestable, by reason of their comparative lightness and strength and their ease in handling, hauling and installing—have accomplished much toward revolutionizing permanent road improvement.

The "Engineering News", a well known technical journal, commenting editorially on Corrugated Metal Culverts, in its issue of January 20, 1910, had the following to say:

"To an Engineer of the old school, accustomed to build always with an eye to permanence and solidity, the idea of putting a culvert of thin corrugated iron under an earth embankment, may seem like a crude makeshift, which ought to be condemned offhand without discussion. Very likely the first use of corrugated iron for culvert was a makeshift; but experience appears to show that under certain conditions culverts of this apparently flimsy construction have made good.

"Such culverts are exceedingly cheap, are very light to transport and place, and have so much elasticity and 'come and go' that they will stay in place when unequal settlement occurs where a much heavier culvert would be cracked and broken. For temporary work such culverts are especially advantageous, as they are cheap to place and can be re-covered if the bank is removed.

"The rapid rusting out of sheet iron or steel exposed to the alternate wetting and drying that a culvert receives, naturally occurs as a foremost objection to corrugated iron culverts, but some of these metal culverts are said to have been in service for some fifteen years. By using a special grade of metal of high purity, the resistance to corrosion is expected to be so greatly increased that the culverts may fairly be classed as permanent construction."

A State Highway Engineer of a western state (Missouri) in a Bulletin some time since issued on the subject of "Bridges and Culverts", had the following to say regarding Corrugated Metal Culverts:

"Large quantities of corrugated metal for pipe-culverts and similar products are put on the markets, some of which give good satisfaction, while others do not. Some of the pipe used for culverts in this state has stood but two years, while others have been in use six times that period and are still good. \* \* \* A good weight and quality of corrugated pipe will last fifteen or twenty years. The difficulty is to know when you are getting a good quality,—and for this reason we advise great care in buying corrugated culvert pipe. Do not buy unless you feel sure of the quality—there are all kinds on the market."

The State Highway Commissioner of an eastern state (Pennsylvania) in a Bulletin lately published on the subject of "Supervisors and Their Duties," says:

\* \* \* "From this fact comes the corrugated metal pipe which has been on the market for several years past. If made of ordinary steel, the use of such pipe cannot be condemned too strongly, but if made of special material containing so small a percentage of impurities as to be practically pure iron, it will be found an economical investment for a township."

The sentiments expressed in the foregoing quotations have been corroborated in numerous papers and reports from time to time by the most eminent Engineers and Metallurgical Chemists in this country. Dr. Allerton S. Cushman, formerly Assistant Director and Chemist, U. S. Department of Agriculture, Office of Public Roads, in a Bulletin recently published said among other things:

\* \* \* "It seems to be a fact that carefully made metal in which the ordinary impurities are cut down to mere traces and in which the heat treatment has been carefully controlled, is much more resistant to corrosion than ordinary types of metal with a comparatively high percentage of impurities. \* \* \* The demand for this type of metal appears to be growing, and it has been largely used for the manufacture of road culverts. \* \* \* The fact that this new metal has been largely specified by culvert manufacturers even at a somewhat added cost, is the best evidence that it is meeting a long felt want in this and allied industries."

Thus it appears that corrugated culverts made of such recognized rust-resisting galvanized material as "No-Co-Ro" Metal, "American Ingot Iron" and "Toncan" Metal instead of ordinary steel, and of the proper gauges, properly gal-

vanized—giving the service that they have for years past—are recognized and accepted as a very formidable and worthy suitor for practical and general adaptability in the culvert field at large.

It is a safe assertion that were it possible to compile a general consensus of conscientious opinions of reliable authorities as well as laymen who have investigated the merits of these improved metals as compared with ordinary steel, the great majority would express themselves as unequivocally in favor of the complete elimination of steel in the manufacture of corrugated culverts.

If any one feature is likely to militate more seriously than another against the prospective future success and permanence of corrugated culverts—whether of steel or the purer metals—it is the continued detrimental exploitation of thin gauge, flimsy material. If people will persist in buying too light weight and otherwise inferior corrugated culverts for no other reason than that they are cheap, only to reap dissatisfaction as they certainly must in a comparatively short time, they should at least be fair enough to withhold judgment until they have given the better culverts a trial and not prematurely and indiscriminately condemn the various other worthy corrugated culverts, made of purer metal and heavier gauges, any of which may be bought at a reasonable price, with general satisfaction assured.

16

## COLUSA'S NEW WATERWORKS

FROM THE "COLUSA DAILY SUN"

In the interior cities of this State the importance of an adequate and good water supply for fire protection and domestic service is being very generally appreciated; so much so that it has become a matter of record that of the incorporated towns in the State still without such service, more than 75 per cent have either concluded to install such a plant, or have the matter under serious consideration.

It seems hardly necessary to emphasize the importance to any community of good sanitation, or to state that the decrease in insurance rates following adequate fire protection more than balance any increase in taxation necessary for financing such an installation.

Colusa, which can boast of a population of more than 2500 inhabitants, one of the most thriving towns of the Sacramento Valley, occupies a position central to the most fertile sections of Northern California. Being one of the oldest towns in this this part of the State, perhaps accounts for the comparatively conservative spirit exhibited for so many years in so far as municipal improvements were concerned. Once, however, the great need of such improvements were observed and the direct as well as the extraneous benefits radiating from a general cleaning up were appreciated, very hearty support was given those who pioneered the movement, with the result that Colusa can now boast of one of the most complete water plants in the State.

The development of the multi-stage centrifugal pump, the gasoline engine, and the electric motor using high voltages has produced a combination of units that enables any town of 1000 to 10,000 inhabitants or larger to obtain an adequate domestic and fire service at a moderate outlay in capital expenditure (well within their legal bonding capacities) and nominal upkeep charge.



The sources of water supply at Colusa are two artesian wells 280 feet in depth, from which the water for domestic use is drawn, with auxiliary suction pipes laid to the river at such levels as to control the lowest possible water level.

The water for domestic service is pumped direct to a 100,000 gallon capacity hemispherical-bottom Storage Tank, mounted on a 97 ft. structural steel tower, but passed directly into the street mains when the fire pumps are in use.

The general arrangement of such an installation, the design and selection of the units best suited for continuous or emergency operation and efficiency, as well as the first cost of the plant, at the same time observing the requirements of the Board of Fire Underwriters of the Pacific Coast, are factors which call for very



careful consideration.

To that end, the engineering firm of Fredk. C. Roberts & Co., of San Francisco, have undertaken to design and standardize such installations calculated to meet the requirements of towns varying in population from 1000 to 10,000, with a view to minimizing the first cost thereof (the expense of manufacture and erection) and bringing within the financial limits of the smaller towns efficient plant for fire protection and domestic service. A brief description of the plants erected at Colusa will give a very good idea of the arrangement employed in towns within the radius of electrical power distribution of the larger power companies.

The machinery installation consists of two 4-stage turbine fire pumps and

## PACIFIC MUNICIPALITIES

motor, and a 2-stage pump and motor for domestic service, both units being directly connected to motors on a continuous line shaft, each being belted back to a 100 H. P. multi-cylinder gas engine which furnishes auxilliary control.

The arrangement of the clutches on the pump line shaft is such that either or all pumps may be electrically or gas engine driven, or either pump may be motor driven, and the other operated by the gas engine.

The 4-stage turbine fire pumps which are direct connected to General Electric Co. 8-75 H. P.—1150 R. P. M.—60 cycle—2200 N.—3 phase Induction Motor, are designed for individual capacities of 700 gallons per minute under 125 lbs.

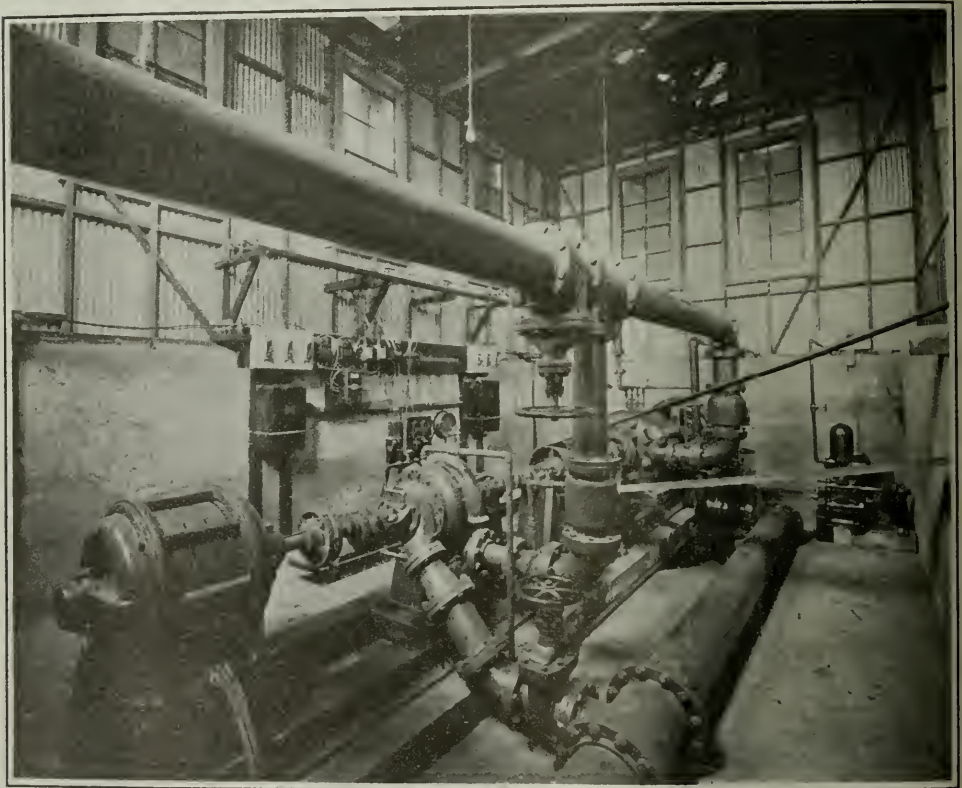

pressure per sq. in., and the 2-stage turbine pump for domestic service direct connected to a General Electric Co. 40 H. P. Induction Motor of the same type, has a capacity of 700 gallons per minute under a pressure of 56 lbs. per sq. in.

The 75 H. P. motor is mounted between the fire pumps and direct connected thereto by jaw clutches. Either pump may thus be controlled by the one motor. Between the motor and pumps, pulleys are mounted on the line shaft, and the units are each belted back to friction clutch pulleys on the extended gas engine line shaft.

The domestic pump is also direct connected to motor and the shaft is extended

to receive a pulley, which is belted back to the friction clutch pulley on the gas engine shaft.

This arrangement, with the necessary clutches, etc., exercises complete control of the pumps by either electrical or gas engine drive.

A friction coupling is mounted on the engine line shaft next to the engine fly wheel, by which the engine may be entirely cut out when starting, thereby permitting proper momentum to be obtained before the load is thrown on. The priming arrangements for the turbine pumps are such that they may be primed from the tank reservoir, or by a vacuum pump, which is independently driven by a General Electric Co., 3 H. P. 110 V. 60 cycle, single phase Repulsion Type

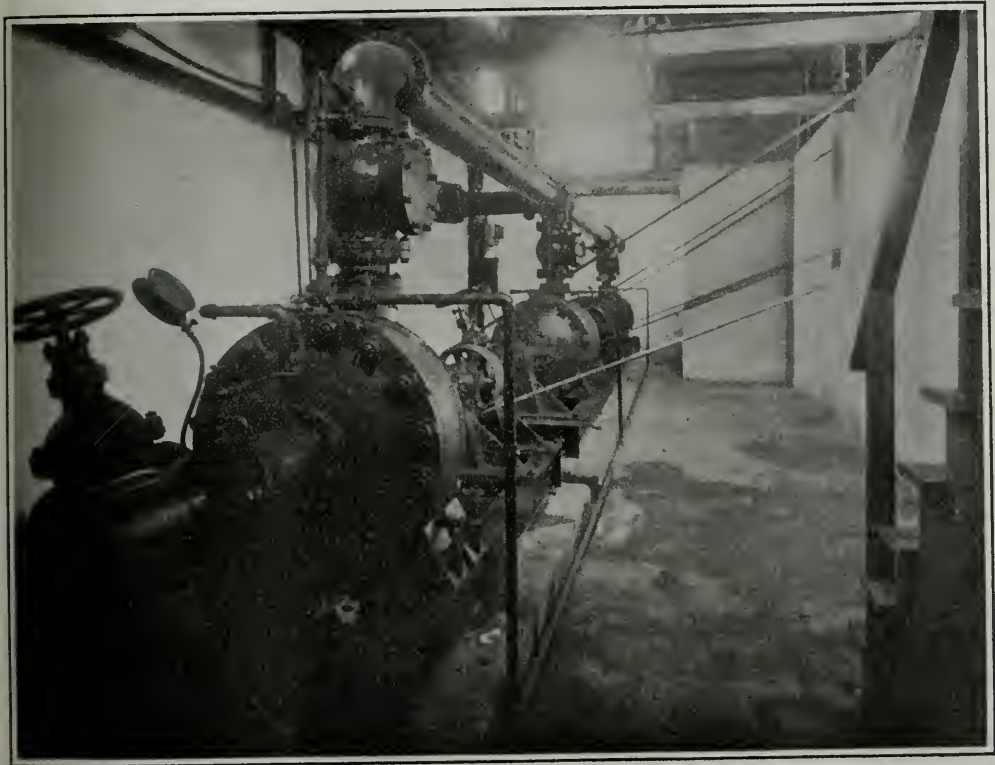

Motor, or by counter shaft belted back to friction clutch pulley mounted on the gas engine line shaft.

The electrical power is distributed to the motors through a T. P. D. T. Oil Switch, which will control power lines entering town from both sides, so that in case one line becomes disabled through fire or other cause, the power may be drawn from the line removed from the trouble.

The 100,000 gallon hemispherical-bottom steel tank supported on a structural steel tower, rises to a height sufficient to give a maximum water elevation of 125 ft. above the top of foundations. This structure was designed and manufactured by the Chicago Bridge & Iron Works, of Chicago, Ill.



## PACIFIC MUNICIPALITIES

These tanks furnish, perhaps, the most sanitary method of storing water, being generally well above the dust and insect horizons and are easily kept clean through a small independent drain pipe. They also afford a very economic means of providing proper pressure for domestic service.

The actual cost of fuel for operating this plant by a gas engine, using No. 1 California Engine Distillate costing  $7\frac{1}{2}$  cents per gallon, at a consumption of 1-10th of a gallon per H. P. hour, is not more than 60 cents per hour. The cost per H. P. or K. W. hour, when electrically driven, is a matter that depends upon the rate arranged between the town and the company furnishing the power.

The important financial responsibilities attending municipal improvements

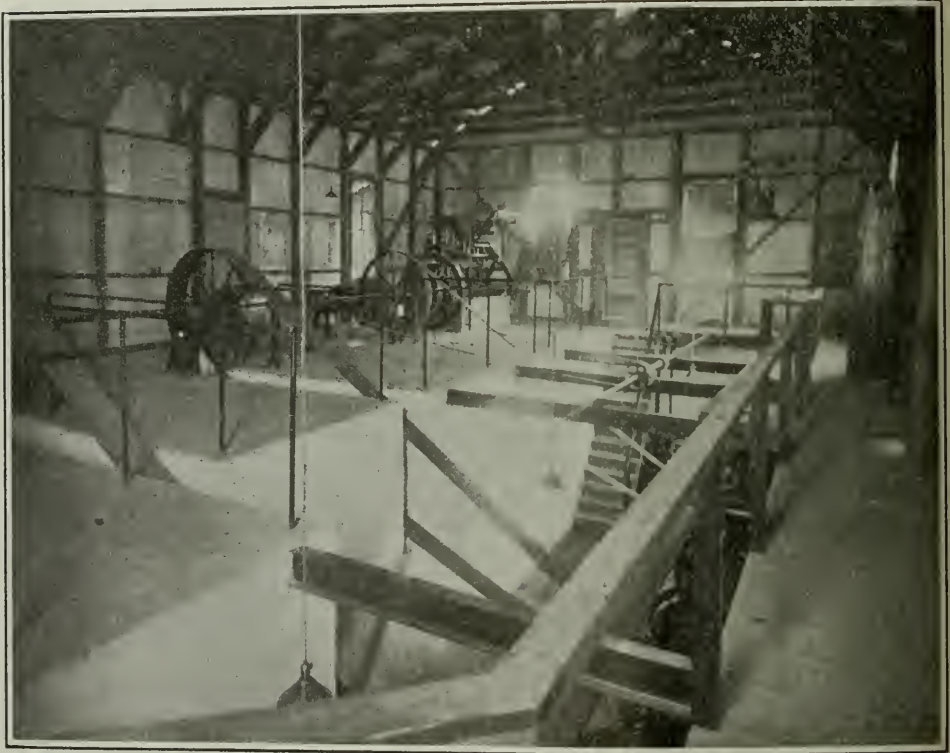

may be said to center round the following departments:

Water Plant and Street Mains for Fire and Domestic Service; Lighting; Sewer Plant; Street Improvements; Public Parks; Public Buildings,

From available records effecting municipal financing on this coast during the past decade, it would seem doubtful if the disbursements accompanying the installation of water, lighting and sanitary plants, street work, parks and their maintenance were always fully comprehended.

The legal bonding capacity of any municipal incorporation is fixed at 15% of the assessed value of the property within such limits. While in the larger cities

with great resources no strain is felt when undertaking public improvements, this is not so of the smaller interior municipalities, where the resources are often taxed to their utmost in order to provide good health conditions (none the less important than in the larger cities) and it is generally necessary to carefully measure the requirement as well as the design and arrangement of plant in order to economically control the conditions and yet keep within the financial limitations.

Referring particularly to municipal water plants for fire protection, when the financial appropriations are exceeded, as they frequently are, not only do mechanical sacrifices have to be made, but the monetary benefits that should accrue in reduced insurance rates and low water rents are largely destroyed because of the need of raising the assessed value of property and taxation necessary to provide further funds.

It is scarcely necessary therefore to emphasize the importance of intelligent consideration tempered with engineering skill of high standard, if moderate first cost, high efficiency and low maintenance charges are to be obtained.

The installation described above appears to incorporate these functions, lends itself to a wide range of flexibility at nominal cost, and the units are entirely free from complicated working parts.

That many of the towns in the interior of the State will in the near future emulate the example set by Colusa, to the end that a clean bill of health may be exhibited and themselves made attractive as a residential place to prospective investors as is the town of Colusa, is pretty well assured.

NOTE: The plant at Colusa is one of several that have been designed, arranged and erected by Fredk. C. Roberts & Co., Engineers, of San Francisco.

## QUESTIONS AND ANSWERS

---

Q.—What are the legal qualifications necessary to practice as a civil engineer and hold the office of city engineer?

Ans.—None are required in this country. An architect, public accountant, pharmacist, doctor, lawyer, dentist, veterinary, and even a plumber must pass an examination before they can go into business, but no license is required to be an engineer.

Q.—Some time ago our City Trustee instructed the Clerk to purchase a number of street lamps. He did so and the firm of J. V. Toscano & Son or rather, through J. L. Toscano, the Junior member of the firm, the order was placed with an Eastern House. J. V. Toscano is one of the City Trustees and according to his statements (which personally I believe are true), the lamps were furnished the City at actual wholesale cost and they were even out expenses on the deal. Toscano of course furnished the city with all bills and freight charges in connection with the same. The bill was allowed. Personally I do not believe this is in conflict with Par. 886 of Act 2348 of the General Laws, provided of course there was no profit made by J. L. Toscano or indirectly by J. V. Toscano, who acted for the Clerk in the matter. The Treasurer has held up the bill pending an investigation of the matter, as he says, in fear of becoming liable himself. He says he has no idea of any graft or any profit being made.

Now is this act of the Board illegal, provided of course there was not a cent of profit made, and is the Treasurer justified in his action and would he be liable in case it was illegal and he paid the bill? I say he would not but have not the authorities.

Ans.—We received a similiar inquiry from your treasurer and he has probably shown you our reply. He did not explain it quite as fully as you have done. If you know, as a matter of fact, that Mr. Toscano is not interested in the contract, directly or indirectly, then the law has not been violated. It would be advisable, however, for the bill to be presented by the firm from whom Mr. Toscano ordered the goods, so there would be no appearance of wrong doing on the records.

The fact that the bill was put in the name of the son who is associated with the father (a city trustee) in business, would give sufficient excuse to question the legality of the claim, but if it is really a fact that the father did not benefit in any way by the transaction, the claim is legal and should be paid.

Q.—I would like to ask you a question. As City Treasurer I should be allowed 1%, as compensation, of all moneys received. To get this money, should I put in a regular claim against the City, have the City Trustee pass on it and order a warrant drawn for the amount, or would it be in full compliance with the law for me to simply show the amount in my Quarterly Report?

Ans.—Sec. 876 provides that you may credit yourself with one per cent of all moneys received and paid by you as treasurer, when you make your quarterly settlements with the clerk. It is not necessary that you put in a claim and have the trustees pass on it, and you may draw the same without a warrant.

Q.—The Commission form of government is being discussed somewhat with the view of making the change here. The Promoters have been presenting views favorable and as usual there must be two sides. Thought perhaps you would give us a little information as to the pros and cons. Also can you inform us what the sentiment of a majority\*of the members of the League meeting at San Diego; as you understand it?

Ans.—Replying to your inquiry of Dec. 1. will say that no vote was taken on the question of commission government, although it was discussed at considerable length in the general body and also in the department of city attorneys. We are inclined to think that if a vote had been taken the result would have been in favor of the commission plan. Those taking the affirmative contended:

1st. That the commission plan follows the plan used in managing an industrial corporation, and is single, practical, effectual and economical; that three or five commissioners can legislate for a municipality with almost as much intelligence, and can administer and execute with far more dispatch than is possible under the old federal plan with its large legislative body and separate executive officials.

2nd. That the commission plan involves a short ballot, which would result in the election of better officials, besides, having fewer elected officials will enable the people to more easily fix the responsibility in case of neglect or wrong doing.

The negatives contend that the commission idea is undemocratic, and reposes too much power in a few hands. Answering this objection the affirmatives claim the initiative, referendum and recall features of the commission plan enables the people to take the power into their own hands at any time they see fit. They admit that while it might be less representative theoretically, it is more practical



and effective, and accomplishes results; and after all, results are what is wanted, even if we have to overturn some of our ancient fictions of law. Those who favor commission government contend also that the administration of municipal government is a matter of business and not a matter of politics, and therefore should be conducted on business principles. (See Pacific Municipalities for December and January.)

Q.—The Chamber of Commerce, Merchants and Manufacturers and City Officials have appointed me one of a committee of three to investigate the alleged benefits of the Commission Plan of government. Would you kindly send us a copy of Pacific Municipalities containing the discussion on this subject which took place at San Diego, and tell us how we may obtain copies of the charters of California cities operating under this system?

Ans.—The discussion will be published in the December and January issues, copies of which will be sent to you. We enclose a printed synopsis of the Des Moines charter and suggest that you write to the City Clerks of Oakland and Berkeley for copies of the charters of these cities.

Q.—The Pacific Telephone & Telegraph Co. served notice on me a few days ago that they would pay no more municipal licenses to the Town of Livermore, declaring that they were exempt under the provisions of Amendment No. 1. How far is this likely to go with licenses and taxation?

Ans.—The adoption of Amendment No. 1 to the Constitution of the State provides that "taxes of every kind and nature (against certain mentioned corporations including gas and electric companies) shall be entirely and exclusively for "state purposes", x x x and *such taxes shall be in "lieu of all other taxes and LICENSES, state, county and MUNICIPAL."* Therefore by reason of the adoption of Constitutional Amendment No. 1, municipalities can no longer impose taxes of any kind, including license taxes, against these corporations. (See editorial in this issue.)

Q.—Kindly advise if it is the proper procedure for the City to assume and pay incidental expenses preparatory to Vrooman Act work.

Should the City advance the necessary money with which to pay for the advertising, expenses of engineering & etc.?

We understand that this is the procedure in the event the work is abandoned but the question has arisen relative to the above and would like to be enlightened.

Ans.—Replying to your inquiry of yesterday, will say that it is customary for the contractor, when he is about to sign up the contract with the street superintendent, to advance all the incidental expenses, including advertising, engineering fees, etc. That is the proper procedure under the Vrooman Act. (See latter part of Sec. 5) The contract should not be signed up until these fees are paid; nevertheless we do not believe there is anything illegal in the city advancing these expenses to the printer, engineer, etc., though there may be some question about it.

Q.—The trustees desire of me to ask you about the following matter:

We have in town a lodging house adjoining a livery stable. The noise of the horses and wagons disturb the lodgers and the smell from the manure is objectionable. How can we handle such a condition?

Ans.—There is no way by which you may regulate the keeping of a livery stable so as to prevent noise. As a sanitary measure you may pass an ordinance requiring that all livery stables within a certain district have cement floors. Such legislation might result in the stable being moved to a less objectional place out of the district.

You may regulate the keeping of manure by requiring that it be placed in covered bins with a cement bottom and provide that no manure be allowed on the premises longer than 24 hours. They have ordinances to that effect in many places. There should be such an ordinance in every town; it would do away with the fly evil to a great extent.

Q.—Does the President of a Board of Trustees of a sixth class city retain the chair as president for any particular time, or does he simply hold at the pleasure of the Board?

Ans.—Replying to your favor of Dec. 15th will say that the member of a Board of City Trustees who is chosen to preside, holds his position subject to the pleasure of the Board, and a new member going on the Board often results in the selection of a new president. As a general proposition the power to appoint carries with it the power to remove.

Q.—Is there any method, other than the one mentioned in Par. 854 of Act 2348 of the General Laws, by which a City Trustee of the Sixth Class, may be removed for failing to attend the meetings of the Board. We have a Trustee who has not attended a meeting for nearly eight months, but he has not been out of the City for ninety days at one time. Is there any section of the Political Code that would apply, this being a city of the sixth class or may this be regulated by Ordinance under the provisions of Par. 859 of Act 2348 of the General Laws?

Ans.—We believe that under Section 859 of the Municipal Corporations Bill, an ordinance would be upheld which prescribed removal from office as one of the penalties for continued absence from meetings. The question has never been judicially settled, "though Judge Dillon expressed the opinion that our municipal corporations, in the absence of any express or implied restriction in the charter, possess the incidental power, not only to make by-laws, but for cause to remove corporate officers, whether elected by it or by the people." See Dillon on Municipal Corporations, Sec. 232-243. Also, *Croly vs. City of Sacramento* 119 Cal. 234.

Q.—In this city there are quite a number of large canals owned by the water companies, carrying water beyond the limits of the city for irrigating purposes. These canals, are way up above the level and grade of the street where they cross the same, and interfere to a great extent with the improvement of these streets, as in order to put the street down to grade and pave it, it becomes necessary to build a siphon to take the water across the street, and at the same time bring it down to the grade level.

While these canal companies may put bridges over these canals so that people may pass, yet these bridges are not so that the street could be paved over them, and I believe that it would be no more than fair that the canal companies should be compelled to siphon those canals so that the streets could be paved over them, and be kept on the official grade. I should like to hear from you as to the feasibility of amending Section 551 of the Civil Code so as to cover this matter.

Ans.—We suggest that you prepare such an amendment and get in touch with other cities that might be similarly affected and see if you can get them and their representatives to join with you in the attempt to put it through, as it might be vigorously opposed.

Q.—After an election as required by statute, our city was declared incorporated on February 28th, 1910, by the County Board of Supervisors. The City Trustees elected thereat failed to subscribe to the oath of office at their first meeting which was held in the middle of March. Owing to the limited time we did not attempt to hold another election on April 11th, as we now understand the law requires shall be done, and as our citizens are petitioning for a bond issue for sewers, we would like to know how the matter may be straightened out.

Ans.—You had better postpone any action on the question of issuing bonds until a validating act may be put through the next legislature. If agreeable, we will prepare the necessary act in this office, and with the assistance of your representatives, try and secure its early passage. Although your present officials are the de facto officers of the municipality and may continue performing their usual functions, you would find it impossible to dispose of any bonds you might vote until their title to office is cleared.

Q.—Our Trustees desire to sell a certain piece of real property belonging to the city, and purchase another. May they sell at private sale and pay commission to a real-estate agent, or must it be advertised and bids be called for?

Ans.—The Trustees are at liberty to sell through a real-estate agent and pay him commission, or at public auction; they should use that method which they believe will enable them to make the best bargain for the city.



When a man feels the necessity of being in two places at the same time he goes to the nearest telephone and sends his voice. It is not exactly the same thing, but when a man talks hundreds of miles in opposite directions from the same Bell Telephone, it is about as good. In the daily use of the telephone a man travels all over town by wire in a few minutes. It is just as easy to travel all over the state and other states by means of the universal Long Distance Service of the Bell System.



The Pacific Telephone & Tel. Co.

Every Bell Telephone is the Center of the System





## EDITORIAL

### FRAMING NEW ORDINANCES

Requests are frequently received at headquarters for information as to the existing ordinances on certain subjects, in the different municipalities of the State. In order to comply with these requests in a more satisfactory manner and thereby incidentally enhance the value of the league, city attorneys and clerks are respectfully urged to send to headquarters copies of their city ordinances where the same have been compiled and published in book form; also, to send hereafter a printed copy of all new ordinances as they are passed.

The work of collecting copies of municipal ordinances was started some times ago, and city attorneys and other officials are invited to make free use of this feature. If you are contemplating the passage of a new ordinance send a request to the league headquarters for copies of ordinances on the particular subject involved and they will be forwarded immediately.



### OUR NEW TAX SYSTEM

Mr. A. L. Henry, Town Clerk and Assessor of Livermore, informs us that by reason of the adoption of Constitutional Amendment No. 1, his town will lose from one-third to one-half the revenue it heretofore received. Is this an exceptional case, or are there other municipalities in the same fix? If so, it is a serious matter.

Under this amendment which has just been adopted, cities and towns are no

longer permitted to collect licenses and taxes from corporations, including railroads, express companies, gas and electric companies, banks, saving and loan associations, etc., etc., and the smaller municipalities will thereby be deprived of a large portion of the revenue which they formerly received. Therefore they are confronted with a situation which demands immediate attention, and it would be advisable for clerks and assessors to look over their assessment rolls and get an idea how they are going to come out. An increase in town tax rates will undoubtedly be necessary in a great many cases, but this raise will probably be offset by the removal of all State taxes on real and personal property.

There is a provision in the amendment directing the legislature to pass such laws as may be necessary to carry out the details of this new tax system and in order that your representatives to Sacramento may act intelligently, it is necessary that they be fully informed as to how the change will affect municipalities. Any information on the subject from clerks and assessors will be gladly received at the league headquarters, and the same will be published in our next issue.



### LICENSES UNDER SENATE CONSTITUTIONAL AMENDMENT NO. 1

Some question has arisen between the representatives of the various public service corporations affected by Senate Constitutional Amendment No. 1, ratified by the people November 8, 1910, as to its effect upon the payment of licenses hitherto levied by counties and municipalities.

The corporations have taken the position that they are relieved from the pay-

ment of such licences, that is, those accruing from and after the date of the passage of the Amendment. The Amendment explicitly declares that "such taxes (i. e. the percentages upon gross receipts therein provided for) shall be in lieu of all other taxes and licenses, State, County and Municipal, upon the property" described therein. Thus, they admit their liability for quarterly licenses accruing on the first of October, which cover the last quarter of the year, but consider that they are relieved of any further licenses, such as, a monthly license becoming due December 1st. Their position would seem to be correct under *Kingsbury vs. Nye* (December 24, 1909) 9 Cal. App. Rep. p. 574, in which a State official made a demand upon the Controller for his salary at an increased rate, provided for in a Constitutional Amendment, from the date of the passage thereof. It was held that his position was well taken and the Appellate Court explicitly stated that such an Amendment went into effect from the time of its ratification.

It is to be remembered, however, that any profit to public service corporations is but temporary, as in July next, an amount will be due from them in excess of all taxes and licenses heretofore paid, which aggregate amount is to take care of State expenses and do away with the imposition of the State rate heretofore imposed. Careful analysis by the State Commission on Revenue and Taxation has shown that the difference between the amount saved by the removal of the State rate and that withdrawn for State purposes by the Amendment, will result in substantial gains to almost every County in the State and in these cases, the Amendment provides reimbursement for a further period of time.

## What the Cities are Doing

**Napa** is putting in a number of sewers.

**Alameda** has several new school houses under construction.

**Morgan Hill** citizens are agitating the construction of a municipal water system.

**Livermore** recently ordered the purchase of a Success Chemical Engine, together with hose.

**Oceanside** has sold its \$20,000 water improvement bonds for par and a premium of \$416.50.

**Vallejo.** The \$60,000 bonds of the Vallejo High School District brought a premium of \$2050.00.

**San Jose.** The Fire Chief has advised the purchase of 2000 ft. hose and another steam or auto fire engine.

**Oakland.** The city council orders the installation of sewers in the annexed district, under the Vrooman Act.

**Lodi** will amend specifications for its municipal electric light plant. The first bids exceeded the money available.

**Coronado** has voted \$36,000 for a sewer system, including an outlet and extensions; also \$10,000 for auto fire apparatus.

**Sacramento** has awarded the contract for erecting its new court house to Lendgren & Co. of San Francisco, for \$539,000.00.

**Placerville** will soon see the commencement of the new Court House and County Jail for which \$120,000.00 was recently voted.

**Ontario** sold \$95,000 water bonds to the First National Bank of Ontario for a premium of \$2000. There were three other bidders.

**San Mateo.** The proposition to issue \$50,000 additional bonds for the San Mateo Union High School carried by a vote of 364 to 124.

**Alhambra** trustees have ordered a bond election for the purpose of voting on the proposition of constructing a \$45,000 public library.

**Martinez** has secured an option on a lot of water front property upon which they propose to establish a salt water fire protection system, as well as municipal piers.

Chico will receive competitive plans for its new \$32,000 City Hall early in January, the building is to be a two-story of brick and concrete.

Stockton will vote on January 24th on the following bonding propositions: Street Improvements, \$290,609.76; Modern Fire Department, \$100,000.00; Sanitary Sewers, \$40,000.00; Rainwater Sewers, \$77,000.00.

San Francisco has awarded a contract to the Destructor Company, Power Specialty Company, Manager, for the construction of two Heenan Refuse Incinerating plants, one to cost \$123,141.00 to be located near Islais Creek, and the other costing \$132,075.00, to be located at North Beach.

Each plant is designed to dispose of 120 tons of mixed refuse in 24 hours.

The plants will be more complete and up to date than anything which has heretofore been attempted in this direction. Included with the furnace are weighing apparatus, mixing device, clinker crushing and screening plants, storage hoppers, for crushed clinker and baling presses for tin cans and scrap iron.

The refuse, after being tipped from the collecting carts at the plant, will be handled mechanically throughout every stage of the process of incineration until the crushed and sized clinker is ready to be drawn off from the storage hoppers into carts or railway cars as a saleable article for building purposes.

The surplus steam not required for the mechanical operation of the plant will be used for the municipal Asphalt plant, the Fire Pumping Stations and for the Municipal Street Railway.



### "HYGENIC" DRINKING FOUNTAIN

For Schools, Railway Stations, etc. Prevents contagion and provides each user with an ample supply of fresh water.

Illustrated circular sent on request.

The newest things in plumbing fixtures for Schools, Factories and Office Buildings are on display in our Show Rooms.

851-859 Folsom Street, San Francisco, Cal.

Phones, Sutter 1130; Home J-2110

**Haines, Jones & Cadbury Co.**

Makers of Plumbing Supplies

1130-1144 Ridge Avenue, Philadelphia

Branches—Savannah and San Francisco

---

## PATRONIZE OUR ADVERTISERS

---

Members of the League can materially assist the upbuilding of our organ, Pacific Municipalities, by favoring our Advertisers wherever possible. They are always pleased to answer inquiries.

Mention Pacific Municipalities when writing to them.



**LIST OF RESPONSIBLE FIRMS TO BE CALLED ON TO BID FOR  
PUBLIC WORK OR SUPPLIES**

**WRITE FOR CATALOGS**

This list is arranged as a guide for the accommodation of city officials where advertising for bids is not necessary.

- Accountant**  
William Dolge, C. P. A., 255 California St., S. F.
- Architects**  
W. H. Weeks, 251 Kearney St., S. F.
- Asphalt Machinery**  
J. I. Case Thresh'g Mch Co. 616 Myrtle St. O'kl'nd  
A. L. Young M'chy Co. 26-28 Fremont St., S. F.
- Arch. Terra Cotta**  
Gladding, McBean & Co., Crocker Bldg, S. F.  
Steiger Terra Cotta & Pottery Wks, 729 Mills Bldg., S. F.
- Automobile Public Service Wagons**  
Consolidated Motor Car Co., Cor. Van Ness and McAllister Sts., S. F.  
The Thomas B. Jeffery Co., 117-125 Valencia St., S. F.  
Reliance Auto. Co., 342 Van Ness Ave., S. F.
- Bitulithic Pavement**  
Warren Brothers Company, Los Angeles, Cal.
- Blue Prints**  
So. Cal. Blue Print & Supply Co., 800 L. A. Trust Bldg., Los Angeles.
- Bridge Builders**  
Keatinge-Bradford Co., 615 Humboldt Bk Bdg.  
E. T. Thurston, Jr., Wells, Fargo Bldg., S. F.
- Concrete Construction**  
Esterly Con. Co., Inc., 717 Market St., S. F.  
Hazelwood, Jones, Doane & Hanscom, 675 Monadnock Building, S. F.
- Contractors and Builders**  
Finch Jail Building and Metal Co., 16 California St., S. F.
- Constructing Engineers**  
Fred'k C. Roberts & Co., 221 Sheldon Bldg, S. F.
- Consulting Engineers**  
Spaulding, Sloan & Robson, 802 Union Trust Building, San Francisco.  
E. T. Thurston, Jr., Wells Fargo Bldg., S. F.
- Drinking Fountains**  
Haines, Jones & Cadbury Co., 851-859 Folsom St., S. F.
- Dump Carts and Wagons**  
J. I. Case Thresh'g Mch Co. 616 Myrtle St. O'kl'nd  
A. L. Young M'chy Co., 26-28 Fremont St., S. F.
- Electrical Plants & Machinery**  
A. L. Young M'chy Co., Fremont St., S. F.  
Chas. L. Kiewert Co., 195 Fremont St., S. F.
- Engravers and Bond Printers**  
A. Carlisle & Co., 251 Bush St., S. F.  
Commercial Art Co., 53 Third St., S. F.  
Schmidt Lith. Co., Second & Bryant Sts., S. F.  
Sierra Art Eng. Co., Front & Com. Sts., S. F.
- Fire Alarm and Police Tel. Systems**  
Gamewell Fire Alarm Tel. Co., Market and Battery Sts., S. F.
- Fire Dept. Equipment**  
Cal. Fire Apparatus Co., Jessie and New Anthony, S. F.  
R. S. Chapman, 400 Golden Gate Ave., S. F.
- Fire Engines**  
Gorham Rubber Co., 50-56 Fremont St., S. F.
- Fire Extinguishers**  
Goodyear Rubber Co., 589 Market St., S. F.
- Fire Hose**  
Gorham Rubber Co., 50-56 Fremont St., S. F.  
Eureka Fire Hose M'fg Co., 610 Postal Tel. Building, S. F.  
New York Belting & Packing Co., 129-131 First St., S. F.
- Gasoline Engines**  
Doak Gas Engine Co., 7-9 First St., S. F.
- Lithographers**  
Schmidt Lith. Co., Second & Bryant St., S. F.
- Metal Furniture**  
Finch Jail Bldg. & Metal Co., 16 Cal. St., S. F.  
Art Metal Construction Co., Flood Bldg., S. F. Story Building, Los Angeles.
- Municipal Accountant**  
William Dolge, C. P. A., 255 California St., S. F.
- Municipal Printers**  
A. Carlisle & Co., 251-253 Bush St., S. F.
- Municipal Pumping and Water Service**  
Fredk. C. Roberts & Co., 461 Market St., S. F.
- Pavement Materials**  
Warren Brothers Company, Los Angeles, Cal.
- Playground Apparatus**  
A. L. Young Machinery Co., S. F.
- Riggers**  
C. A. Blume Con. Co., 185 Stevenson St., S. F.
- Road Machinery**  
J. I. Case, Threshing Mch. Co., 616 Myrtle St., Oakland, Cal.  
Henshaw, Bulkeley & Co., Fremont St., S. F.  
A. L. Young M'chy Co., Fremont St., S. F.  
Petrolithic Pav. Co., 209 E. 7th St. Los Angeles
- Safes**  
Cary Safe Co., 669-671 Mission St., S. F.  
Parcells Safe Co., 577 Market St., S. F.  
Victor Safe & Lock Co., 1292-4 Market St. S. F.
- Scrapers**  
J. I. Case Thresh'g Mch Co. 616 Myrtle St. O'kl'nd  
A. L. Young M'chy Co., Fremont St., S. F.  
Petrolithic Pav. Co., 209 E. 7th St. Los Angeles
- Sewer (Concrete)**  
Esterly Con. Co., Inc., 717 Market St., S. F.
- Sewer Pipe and Terra Cotta**  
Gladding, McBean & Co., Crocker Bldg, S. F.  
Steiger Terra Cotta Co., Mills Bldg., S. F.
- Sidewalks (Cement)**  
Esterly Con. Co., Inc., 717 Market St., S. F.
- Street Signs**  
A. L. Young Mch. Co., S. F.
- Street Sweepers**  
A. L. Young M'chy Co., Fremont St., S. F.
- Structural Steel Erectors**  
C. A. Blume Con. Co., 185 Stevenson St., S. F.
- Vaults**  
Cary Safe Co., 669-671 Mission St., S. F.  
Parcells Safe Co., 577 Market St., S. F.  
Victor Safe & Lock Co., 1292-4 Market St., S. F.
- Water Supply**  
Doak Gas Engine Co., 7 and 9 First St., S. F.



Three Lines of 60-inch Cast Iron Pipe

## United States Cast Iron Pipe and Foundry Co.

Pacific Coast Sales Office: Monadnock Building  
San Francisco, Cal.

General Offices: 71 Broadway, New York

Cast Iron Pipe In All Regular Sizes  
3 inch to 84 inch.

For WATER, GAS, SEWAGE,  
DRAINS, CULVERTS, Etc.

Flanged Pipe, Flexible Joint Pipe, Special  
Castings, Large Cylinders, Heavy Castings

Works at Addystone, Ohio, Anniston, Ala., Bessemer, Ala., Burlington, N. J.,  
Chattanooga, Tenn., Buffalo, N. Y., Cleveland, Ohio, Superior, Wis., Columbus,  
Ohio, Louisville, Ky., Scottsdale, Pa.

# CAST IRON PIPE



For Water, Gas, Sewage, Drains, Culverts, etc.  
All regular sizes, 3 in. to 84 in. Flange Pipe,  
Flexible Joint Pipe, Specials, Heavy Castings,  
High Pressure Fire Service.



Six High Pressure Streams from One Stand

About 1,500,000 tons of  
CAST IRON PIPE  
used annually in the  
United States for gas and  
water mains.

50,000 tons heavy cast  
iron pipe used for the  
new Auxiliary High Pres-  
sure Fire System in San  
Francisco, furnished by  
this company.

Every city of importance  
in the United States uses  
CAST IRON PIPE for  
its distribution system.

CAST IRON PIPE is fast  
becoming a factor as used  
for gate houses, reservoir  
connections, for syphons  
in crossing valleys and  
for supply mains.

## United States Cast Iron Pipe and Foundry Co.

### WORKS:

Addyston, Ohio,	Burlington, N. J.	Columbus, Ohio	Anniston, Ala.
Chattanooga, Tenn.	Louisville, Ky.	Bessemer, Ala.	Scottdale, Pa.
Superior, Wis.	Buffalo, N. Y.	Cleveland, Ohio	

Pacific Coast Sales Office: Monadnock Building, San Francisco, Cal.

GENERAL OFFICE, 71 BROADWAY, NEW YORK





**Fire Apparatus**  
**Police Patrol**  
**Ambulances**

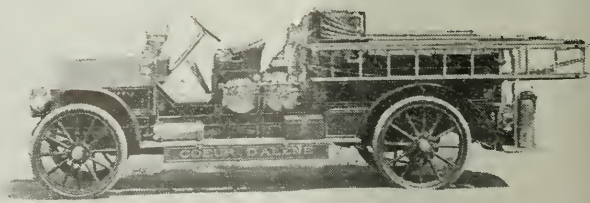

REPRESENTED BY

**RELIANCE AUTOMOBILE CO.**

342-352 Van Ness Ave.
SAN FRANCISCO

F. W. Haselwood, Assoc. M. Am. Soc. C. E.
Sidney Jones
E. W. Doane
W. A. Hanscom

**Haselwood, Jones, Doane & Hanscom**  
*Civil, Hydraulic and Sanitary Engineers*

*Sewers, Waterworks, Light Plants, Street Work and Bridges*

Phone Sutter 1337
675-677 Monadnock Building
SAN FRANCISCO, CAL.

<p><b>E. T. THURSTON, Jr.</b> Assoc. M. Am. Soc. C. E. <b>Consulting Engineer</b> 713 Mechanics' Institute Phones Sutter 1683 and C 2895      SAN FRANCISCO</p>	<p><b>Specialties</b> Design and Supervision of Buildings, Bridges, Railways, Water Works and Municipal Work <b>Concrete Bridges</b> Exclusive rights under patents of National Bridge Company, the largest in the world. Estimates furnished free of charge.</p>
---------------------------------------------------------------------------------------------------------------------------------------------------------------------------------	-------------------------------------------------------------------------------------------------------------------------------------------------------------------------------------------------------------------------------------------------------------------------------------------

**C. A. BLUME CONSTRUCTION CO.**  
Members of Builders Exchange  
**Structural Steel Erectors**  
**Riggers**

Phone Douglas 324  
185 STEVENSON STREET
SAN FRANCISCO

**ESTERLY CONSTRUCTION CO., Inc.**  
**CONCRETE CONTRACTORS**

Buildings, Bridges, Sidewalks, Walls, Floors, Foundations

Room 605, 717 Market St., San Francisco
2136 Center St., Berkeley



SIERRA ART & ENGRAVING Co.

COMMERCIAL ARTISTS  
PHOTO ENGRAVERS

SIERRA BLDG. SAN FRANCISCO

**WILLIAM DOLGE**

*Certified Public Accountant --:-- Municipal Accountant*

TELEPHONE DOUGLAS 5173

255 California Street

San Francisco, Cal.

**WM. H. WEEKS, Architect**

PUBLIC BUILDINGS A SPECIALTY

251 Kearney Street

San Francisco

**SPALDING, SLOAN & ROBSON**

CONSULTING ENGINEERS

Waterworks, Sewer Systems, Paving, Lighting Plants

Telephone Kearney 4646

802 Union Trust Building, SAN FRANCISCO

Chas. P. Bradford, President

M. Keatinge, Vice-Pres. and Supt.

Howard J. Van Kirk, Secretary

**KEATINGE-BRADFORD COMPANY**

Concrete Contractors and General Contractors

Telephone, Kearny 2921

Room 615 Humboldt Bank Building

SAN FRANCISCO

**GORHAM RUBBER CO.**

RUBBER GOODS OF EVERY DESCRIPTION

Fire Hose, Chemical Engines, Hose Carts, Packing

**50-56 Fremont St., San Francisco**

W. J. LOCKE

H. A. MASON

**Mason & Locke**

ATTORNEYS AND COUNSELORS AT LAW

*Bond proceedings conducted---validity and sale guaranteed*

Ninth Floor Pacific Building

SAN FRANCISCO

The  
Bitulithic  
Pavement  
For Streets  
and Roads



1902	1 Mile	7 Cities
1903	22 Miles	33 "
1904	52 "	40 "
1905	59 "	45 "
1906	85 "	57 "
1907	109 "	66 "
1908	95 "	62 "
1909	118 "	74 "
	679 "	216 "

**TOTAL MILES (30 Ft. Road)**

Combines the inherent stability of the mineral aggregate with the cementing qualities of the asphaltic oil, or other bituminous cement, and produces a smooth, dustless, waterproof pavement, suitable for automobile traffic and driving--prevents skidding and affords a good foothold for horses--is COVERED BY PATENTS, the VALIDITY of which has been SUSTAINED BY THE SUPREME COURT OF THE UNITED STATES.

Send for circulars showing where used and methods of construction.

**WARREN BROTHERS COMPANY**

Portland, Ore.

Boston, Mass.

Los Angeles, Cal.

616 Laughlin Bldg.

REGISTERED TRADE MARKS

"Bitulithic" "Warrenite" "Puritan" "Bitrock" "Bituminous Macadam" "Biustone"

**MAPS**  
**BONDS**  
**STATIONERY**  
**BOOKLETS**  
**POSTERS**  
**LABELS**  
**CARTONS**  
**ETC.**

**SCHMIDT LITHOGRAPH COMPANY**

MAIN OFFICE  
SAN FRANCISCO.

PORTLAND      LOS ANGELES

**FINCH JAIL BUILDING AND METAL CO.**



Manufacturers and Builders of

**PRISON CELLS AND ALL APPURTENANCES.**

Dealers in Metal Furniture and Fixtures

Office No. 16 California St.

Telephone Kearney 935



# SPECIAL BARGAINS IN THE BEST MAGAZINES

1. Review of Reviews - - \$3.00 } All American Magazine - - 1.50 } For Sunset Magazine - - 1.50 } <b>\$3.25</b>	2. Review of Reviews - - \$3.00 } All Woman's Home Companion 1.50 } For Sunset Magazine - - 1.50 } <b>\$3.50</b>
3. American Magazine - - \$1.50 } Both Sunset Magazine - - 1.50 } For <b>\$2.00</b>	4. Woman's Home Companion \$1.50 } Both Sunset Magazine - - 1.50 } For <b>\$2.25</b>
5. American Magazine - - \$1.50 } All Woman's Home Companion 1.50 } For Sunset Magazine - - 1.50 } <b>\$2.75</b>	6. Technical World - - \$1.50 } Both (or World Today) - - 1.50 } For Sunset Magazine - - 1.50 } <b>\$2.35</b>
7. Forest and Stream - - \$3.00 } Both Sunset Magazine - - 1.50 } For <b>\$3.00</b>	8. Van Norden's - - \$1.50 } Both Sunset Magazine - - 1.50 } For <b>\$2.00</b>
9. Forest and Stream - - \$3.00 } All Womans Home Companion 1.50 } For Sunset Magazine - - 1.50 } <b>\$3.50</b>	10. American Magazine - - \$1.50 } All Technical World - - 1.50 } For Sunset Magazine - - 1.50 } <b>\$2.75</b>
11. Review of Reviews - - \$3.00 } All Van Norden's Magazine 1.50 } For Sunset Magazine - - 1.50 } <b>\$3.10</b>	12. McClure Magazine - - \$1.50 } Both Sunset Magazine - - 1.50 } For <b>\$2.35</b>
13. Scientific American - - \$3.00 } Both (New subscriptions only) } For Sunset Magazine - - 1.50 } <b>\$3.00</b>	14. Review of Reviews - - \$3.00 } At American Magazine - - 1.50 } Half Woman's Home Companion 1.50 } Price Technical World - - 1.50 } All Van Norden's Magazine 1.50 } For Sunset Magazine - - 1.50 } <b>\$5.25</b>

## Sunset Magazine, \$1.50 the Year

CLUBS may be split to go to different addresses.

FREE with each order, two beautiful four color pictures of Yosemite Valley, ("El Capitan" and "Vernal Falls") handsomely mounted. These pictures will be sent flat, not rolled.

POSTAGE to Canada is 50 cents extra on each magazine; to foreign countries is \$1.00 extra.

### SUNSET MAGAZINE FOR 1910 INCLUDES

- (1) A California novel "The Rules of the Game" by Stewart Edward White—to be run as a serial.
- (2) Mexico Today—a series of articles of great interest, by one high in authority in our sister republic.
- (3) Alaska and the Alaskans, by Governor Walter E. Clark.
- (4) The best fiction by such authors as Jack London, Billie Glynn, Eleanor Gates, Dave Coolidge, James Hamilton Osborne, etc.

And many other special features.

ADDRESS

## SUNSET MAGAZINE

313 Battery Street

San Francisco

# MUNICIPAL AND CONTRACTORS' MACHINERY

...FOR...

## GOOD ROADS AND STREETS

- Street Signs
- National Road Machines
- Fort Wayne Road Machines
- Indiana Road Machines
- National Elevating Graders
- Elevators—Portable Bunkers
- Shares or Cutting Edges for all types of Road Machines
- Rock Crushers, Jaw and Gyratory Type, mounted and unmounted
- Screens
- Steam Road Rollers
- Horse Rollers
- Scarifiers
- Harrows for oiled roads
- Wheeled and Drag Scrapers
- Fresno Scrapers
- Reversible Road Plows
- Street Sprinklers
- Sprinkling Attachments
- Street Sweepers
- Fibre for Street Sweepers
- Patent Dump Wagons
- Asphalt Machinery
- Kettles—Hand Rollers—Tampers
- Concrete Mixers
- Hoisting Engines
- Playground Apparatus
- Culvert Pipe

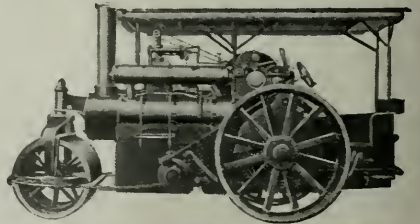

Write us for Catalogues and Estimates

## A. L. Young Machinery Co.

26-28 Fremont Street

San Francisco

California



# PACIFIC MUNICIPALITIES

THE CITY BEAUTIFUL



PUBLIC  
SAFETY  
HEALTH  
CONVENIENCE

PUBLIC  
UTILITIES  
EDUCATION  
RECREATION

PUBLISHED MONTHLY

SIERRA SF





When a man feels the necessity of being in two places at the same time he goes to the nearest telephone and sends his voice. It is not exactly the same thing, but when a man talks hundreds of miles in opposite directions from the same Bell Telephone, it is about as good. In the daily use of the telephone a man travels all over town by wire in a few minutes. It is just as easy to travel all over the state and other states by means of the universal Long Distance Service of the Bell System.



**The Pacific Telephone & Tel. Co.**

*Every Bell Telephone is the Center of the System*



**SILENT**

**LUXURIOUS**

**3 MODELS**

**THE NEW Rambler**

Touring Cars, Motor Fire Trucks, Chemical, Hose, Police Patrol and Ambulances a Specialty.

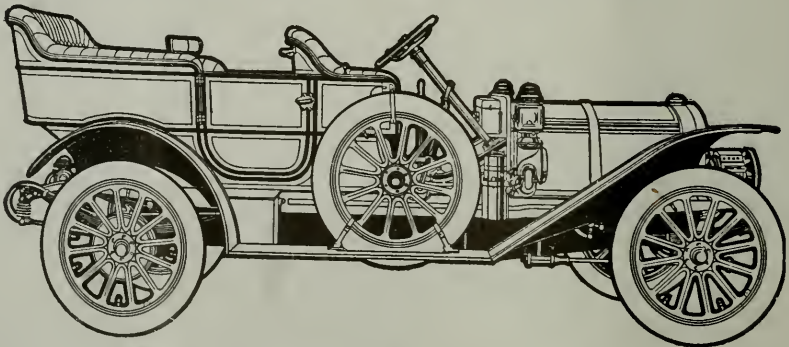

**The Thomas B. Jeffery Co.**

117-125 Valencia St.

WRITE FOR INFORMATION.

San Francisco

Please mention PACIFIC MUNICIPALITIES when writing to Advertisers

# CASE LINE...

Municipal Hauling Engines  
 Contractors' General Purpose Engines  
 Steam Steered Road Rollers  
 12 @ 16 Bbl. Mounted Fuel and Water  
 Engine Tenders for Engines and  
 Road Rollers  
 Troy Bottom Dump Wagons  
 Road Graders  
 Road Scrapers  
 Road Rooters and Road Drags

Write for our general catalog "M." Address Road Machinery Department.

**J. I. CASE THRESHING MACHINE COMPANY, Inc.** RACINE, WIS.,  
 U. S. A.

BRANCH OFFICE, 616 MYRTLE ST., OAKLAND, CAL.

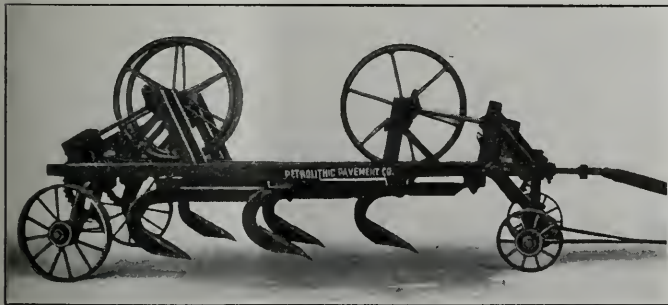

Let us tell you  
 about the new

**Petrolithic Gang  
 Road Rooter and  
 Scarifier**

**THE PETROLITHIC CO.**  
 345 P. E. Bldg.  
 Los Angeles



Wherever good Contractors are,

there the Watson dump wagon is known.  
 It's the most used dumping wagon in  
 America, both by contractors and municipi-  
 palities.

Only one single type of wagon is made in our big factory. All our time and money is devoted to doing one thing, and doing it well. Our printed matter is as high grade as the wagon. Ask for it.

**WATSON WAGON COMPANY, Canastota, New York**

The First Builders of Bottom Dumping Wagons

California Agencies: San Francisco, A. L. Young Machinery Co. 26-28 Fremont St.; Los Angeles, L. M. Davenport Co.



Under the five tracks of the Santa Fe at 40th & San Pablo Ave., Oakland, Cal.

## This Part Circle Corrugated Culvert will last a lifetime



It is made of genuine **American Ingot Iron** which resists corrosion because of its extreme purity, and is also heavily galvanized. It is 99.94% Pure.

The largest steam and electric railways use our Corrugated Metal Culverts in full-circle and part-circle forms because years of service under severe conditions have proven them to be the most durable and satisfactory culvert on the market today. Its superior economy lies in the fact that it will last longer than any iron or steel culvert, and its cost is less than any other permanent construction.

Part Circle Culverts can be built to fit any opening, and when installed have all the strength of full circles. It is the ideal culvert where there is not sufficient head-room for full-circle culvert.

---

### California Corrugated Culvert Company

Los Angeles, Cal.

West Berkeley, Cal.



NOTE—Every city official in California reads Pacific Municipalities.

# Pacific Municipalities

OFFICIAL ORGAN OF THE LEAGUE OF CALIFORNIA MUNICIPALITIES

Entered at Post Office, Santa Clara, Cal., as Second-Class Matter

---

VOL. XXIII

TWELFTH YEAR

No. 6

---

EDITORS - - - H. A. MASON AND WM. J. LOCKE  
EDITORIAL OFFICE - NINTH FLOOR, PACIFIC BLD'G, SAN FRANCISCO  
PUBLICATION OFFICE, - - - SANTA CLARA, CALIFORNIA

---

## CONTENTS FOR JANUARY, 1911

---

Proceedings of the Thirteenth Annual Convention of the League of California Municipalities .....	261
Department of Engineers, Councilmen and Street Superintendents .....	261
Before the General Body.....	281
The Benefit Resulting From Municipal Lighting in Pasadena .....	281
Revision of the Vrooman Act.....	291
Questions and Answers .....	293
Will Test the Validity of Amendment.....	295
Safeguarding Records From Fire.....	296
Editorial .....	297
The Proposed State Highways .....	297
Chicago's Municipal Congress.....	297
Trade Notes.....	297
Coming .....	298
What the Cities Are Doing.....	299

---

Published Monthly. Yearly Subscription, \$2.00 in Advance. Single Copies, 25 Cents

ADVERTISING RATES ON APPLICATION

Address all Communications to "PACIFIC MUNICIPALITIES" Pacific Building  
San Francisco, California

# LEAGUE OF CALIFORNIA MUNICIPALITIES

Organized 1897

## — OFFICERS —

President - - - (Mayor of Berkeley) - BEVERLY L. HODGHEAD  
 First Vice-President - (Councilman of San Diego) - A. E. DODSON  
 Second Vice-President - (Mayor of Santa Cruz) - T. W. DRULLARD  
 Secretary - H. A. MASON Ass't Secretary - Wm. J. LOCKE

## STANDING COMMITTEES

EXECUTIVE—Beverly L. Hodghead; H. A. Mason; S. C. Evans, Mayor of Riverside; Percy V. Long, City Attorney San Francisco; W. P. Butcher, City Attorney Santa Barbara.  
 LEGISLATIVE—W. F. Hyde, Palo Alto; J. O. Walsh, San Francisco; J. H. Strait, Redlands; F. H. Allbright, Red Bluff; B. L. Barney, Hanford.  
 JUDICIARY—C. N. Kirkbride, San Mateo; P. G. Sheehy, Watsonville; Stephen G. Long, Long Beach; R. E. Rhodes, Madera; Wm. J. Carr, Pasadena.  
 ENGINEERING—Chris. P. Jensen, Fresno; C. H. Pieper, San Jose; A. P. Noyes, Vallejo; R. C. Tumelty, Stockton; O. E. Stewart, Anaheim.

Secretary's Office and Headquarters of the League, - Pacific Building, San Francisco

## INFORMATION BUREAU

The League of California Municipalities maintains, in connection with the Secretary's Office, an Information Bureau where the officials of the municipalities belonging to the League can secure information on all subjects relating to municipal affairs.

## MEMBERSHIP

Alameda	Lindsay	Riverside
Albany	Livermore	Sacramento
Alhambra	Lodi	San Bernardino
Anaheim	Lompoc	San Buenaventura
Antioch	Long Beach	San Diego
Auburn	Los Angeles	San Francisco
Bakersfield	Los Banos	San Jose
Benicia	Los Gatos	San Leandro
Berkeley	Loyalton	San Luis Obispo
Biggs	Madera	San Mateo
Bishop	Martinez	San Rafael
Black Diamond	Merced	Santa Ana
Burlingame	Mill Valley	Santa Barbara
Calistoga	Modesto	Santa Clara
Chico	Monterey	Santa Cruz
Coalinga	Mountain View	Santa Maria
Colton	Napa	Santa Monica
Colusa	National City	Santa Paula
Compton	Nevada City	Santa Rosa
Coronado	Newman	Sausalito
Corona	Newport Beach	Sebastopol
Covina	Oakland	Selma
Crescent City	Ocean Park	Sierra Madre
East San Jose	Oceanside	Sisson
Elsinore	Orange	Sonoma
Emeryville	Oroville	Sonora
Escondido	Oxnard	South Pasadena
Etna	Pacific Grove	South San Francisco
Eureka	Palo Alto	St. Helena
Fairfield	Pasadena	Stockton
Ferndale	Petaluma	Suisun City
Fort Jones	Piedmont	Susanville
Fresno	Pinole	Tehachapi
Gilroy	Placerville	Tulare
Glendale	Pleasanton	Vacaville
Hanford	Point Arena	Vallejo
Hayward	Pomona	Visalia
Hercules	Red Bluff	Watsonville
Hermosa Beach	Redding	Whittier
Huntington Park	Redlands	Willits
Imperial	Redondo Beach	Winters
Jackson	Redwood City	Woodland
Lakeport	Richmond	Yreka
Lemoore	Rio Vista	

Every city belonging to the League of California Municipalities is entitled to a free copy of this magazine every month for each of its officials; if not received kindly notify the Secretary. See that your City is in the above list.

# PACIFIC MUNICIPALITIES

A Journal for Progressive Cities

VOL. XXIII

JANUARY 31, 1910

No. 6

PROCEEDINGS  
THIRTEENTH ANNUAL CONVENTION  
OF THE  
LEAGUE OF CALIFORNIA MUNICIPALITIES  
HELD AT  
SAN DIEGO, CALIFORNIA, November 15th to 19th, 1910

CONTINUED FROM DECEMBER

Mr. Locke wished some illustration of what we had been doing in Riverside, and if you will take a little time with me, I will show you something of the streets as we found them when we undertook the work, and something of what has been done to those same streets since, by way of stereopticon views.

A DELEGATE. Will you give us some information as to how you handle the roots of eucalyptus trees in the neighborhood of sewers.

Mr. REED. In the first place, we are trying to keep the eucalyptus tree out of our streets as far as possible, I must say, however, that we have not had so much trouble with eucalyptus trees on our streets, though we have comparatively few of them.

THE PRESIDENT. I will say that, if anyone is interested in the subject, and will leave his name with me, I will mail him our latest annual report, giving something of our trees, their ages and their growth.

MAYOR ORR. What is the width of the parking space between the curb-line and the sidewalk?

THE PRESIDENT. It varies, Mr. Orr.

Mr. REED. We have few parking spaces that are less than four feet. On our 16-foot sidewalks, and the most of our sidewalks are 16-foot sidewalks, we have 5 feet of pavement, one foot from the boundary line, giving us 10 feet of the sidewalks, and, Mr. President, I would like to say one thing which has impressed me very much looking about San Diego. I do not believe our city officials are giving enough attention to the matter or to the complaint that has come from eastern



people, that we are making our roadways too wide. Where you have double lines of railroad tracks you must have wide streets. But on residence streets I think the roadways should be narrowed up and the parking space increased in width.

MR. R. M. WALLACE, of Alhambra. I would be glad to have Mr. Reed hand us six varieties of trees, in his order of preference, for street planting.

MR. REED. We haven't six varieties yet. But in reference to that question, that must be determined by your location somewhat. That is one reason why I have not said anything upon that phase of the subject. In the northern part of the State, you will find different trees from those you will find in the south. And there will be variations even in the south. In the Riverside country, we have as yet found very few trees that we have thought wise to plant for street trees. As I said in my paper, the street is no place for experiments with trees. In New England and in Ohio, it is almost exclusively the maple trees. In New England, too, they have the elm. We do not use either of those. Here we must be limited to a few varieties. With us, the pepper-tree stands first, the most beautiful avenue trees, as we think, properly treated. We are planting, next, the black acacia. We do not like it altogether, but we are getting very good effects from that. But it has to have some special treatment, and it is not the most desirable in color. We are planting the palm where a shade tree is not desired. For instance, our city extends out into the orchard district, and along orchards the palm is the most desirable tree. Then there is the camphor tree, which does very well there, but requires special attention. The pepper, the black acacia, the camphor, and the palm are the trees that we use, with the canariensis where the park spaces are wide enough. With the black acacia, we cut the tops off, and then they spread out and make a very fine tree.

MR. KIRKBRIDE. Do you use deciduous trees, or recommend them at all?

THE PRESIDENT. No.

MR. FIREY, of Ponomia. Speaking of the black acacia, I would like to give our experience with that particular tree. We have some of them in Ponomia, but they are very unsatisfactory on the east and north side of the street, for the reason that they shed their leaves nearly the year round, and it keeps your lawn littered continually. I have them in front of my place, and although they are a very beautiful tree and grow very rapidly, they are a great nuisance on the east and north side of the street. I had a pile of leaves on my lawn that I think must have covered a space of thirty feet by two or three feet deep, just from a few trees.

THE PRESIDENT. We have not found any objection to the black acacia on that score. It is a beautiful tree if treated right, and grows well, and will adapt itself to small parking spaces, and does not interfere with the sidewalk, never raising the cement, and has many admirable qualities. For anything that you have in this world, you have to work, and there are few trees that are adapted to all conditions.

MR. HANNEMAN, of Hermosa Beach. I have had the same experience that the gentleman from Pomona related with regard to the black acacia. I find the leaves are a continual nuisance. I also have pepper trees, and they help to keep me busy, too.

SECRETARY MASON. Mr. President, people in the northern part of the State are more interested in the planting of deciduous than evergreen trees. We want shade in the summertime and sun in the wintertime. If Mr. Reed could give us any information on the better class of deciduous trees, I would like to

have it. I will say that I have been making some investigations along the line, as to the desirable deciduous trees for the northern part of the State, and I have been told and I have noticed that one of the most desirable trees of that character is our native California maple. It is a very handsome tree, and fairly rapid in growth and, being indigenous, is bound to do well in almost any soil in our climate. I have planted a few of the Oriental plane trees and the European sycamore, and they are making a fairly rapid growth, and promise to become very handsome trees. We should emphasize the necessity of having as wide parking spaces as possible, and as narrow roadways as are consistent with the public good. The sidewalk space should never be less than fifteen feet, that is, if there are no street car lines in the street, fifteen feet for the entire sidewalk, out of which to take five feet, leaving nine or ten feet for your parking spaces, the curb being considered. A roadway 25 to 30 feet wide is sufficient for all ordinary traffic, and the best engineers of the present time are considering that sufficient. It also operates to reduce the cost of your pavements and macadamizing, sprinkling and cleaning the streets after they are laid. So, if you will plan your street that way, and set out and plant some known tree that will surely thrive, I think you will have wonderful success. I emphasize and endorse Mr. Reed's remark on the absolute necessity of the public tree. I know what it means. You can't get uniformity, you can't get system, you can't get even a moderate degree of beauty, by leaving all those matters to the initiative of the property owners.

**THE PRESIDENT.** The European sycamore is a very fine tree, and grows very well indeed. I will state that last year we put in \$6500 in street tree planting in our city.

**MR. F. P. SHAW** of Ventura. About the width of the streets, Mr. President. In Ventura we have a very beautiful little place, laid out a long time ago, before the City Councils held conventions of this sort, and the people laid it out for wide streets, and didn't know much about tree planting or the width of the walks. They laid out 60 foot streets all over town, and they gave only 10 feet for the walks, 40 feet being allowed for traffic. We have recently paved by bitulithic pavement all of our streets in town. Now we are in this condition. We have no trees to speak of in Ventura in the streets, and I regret that we could not lay it out all over again and do it on more modern lines, and have some of that sixty feet for trees.

**MR. JOHNSON**, of Santa Barbara. Mr. Reed spoke of the advantage of the pepper trees. We in Santa Barbara favor the pepper trees and have many nice residences with pepper trees on the street. But our parking space is quite narrow, and we have found that the roots of the trees interfere seriously with our curbs, our sidewalks and our gutters, by raising them. What do you do in Riverside in that connection?

**THE PRESIDENT.** Take up the block of pavement and lay it over again after cutting out the surface root. That is what we do—and pay for it. The tree is like an automobile—you can't run it without gasoline, and you have to pay for the gasoline.

**MR. LOCKE.** In regard to the matter touched upon by the gentleman who just spoke, it is not possible to direct the root of the trees?

**THE PRESIDENT.** Yes. The cutting of the roots is only done where the trees are old. We have not had much trouble with the trees that we have planted, because, after the improvements are in, we plant the parking space, and we do not have the same trouble, because we can get the grade better and perhaps plant the tree a little low. We do not have the same trouble with the newly

planted trees as with the old ones. But whenever they raise the sidewalk, we take up the block and cut off the roots.

A DELEGATE. Suppose that happens to be the main root?

THE PRESIDENT. If you have a thing of that kind, you will have to take the tree out or go around it. I would rather go around it. You do not have to have a straight line in order to go home *every* night—you can get home by any route in Riverside. I think a few variations even in streets and sidewalks are more than permissible. I know the newcomers who settle with us speak very highly of our street trees, and it catches the notice of people who do not stay with us.

MR WIELAND. In Berkeley we have the same trouble—some people complain about the sidewalks being lifted up. We have presumed and told them that the tree is of much more importance than the sidewalk. In some of the streets, the Street Department has recently been repairing those sidewalks.

THE PRESIDENT. Rather than patch every little piece, our Street Superintendent has adopted the policy that we take up those little places and temporarily patch them up with oil, and wait until we get a little bunch of them, and then go around and do the work substantially.

MR. REED (in the course of remarks while exhibiting the pictures.) I will say that the right policy for our growing towns is to plant the trees as the streets are laid out. Our pepper trees demand treatment. The top is taken off. From the second year, the growth of the pepper is very little. We find it practicable in some places, where we cannot get all of the telegraph or telephone wires above the trees, that we can raise the top of the trees so that the wires can all be run below the foliage.

MR. LOCKE. I asked a question as to whether or not it is possible to direct the root of the tree. I have seen it stated—and I would like somebody here who probably knows the fact to inform us about it—that the roots of a tree may be directed downward by planting the young tree in a can and cutting out the bottom of the can afterwards when the tree is finally planted.

THE PRESIDENT. I think that is a correct statement. I have planted apple trees, and I know I can direct the roots of apple trees somewhat by planting them specially, under certain conditions, and make them grow differently from what the ordinary apple tree would grow. I imagine the same would apply to street trees.

He

## DEPARTMENT OF ENGINEERS, COUNCILMEN, AND STREET SUPERINTENDENTS

Editor's Note.—The following valuable and interesting discussion on street paving was illustrated with stereopticon views made from photographs of some of the best streets constructed in California.

THURSDAY, NOVEMBER 17, 1910. 9 O'CLOCK A. M.

The Section was called to order by President Van Ornum.

THE PRESIDENT. There have been a good many delegates who have suggested that we take up an informal discussion of street pavements and kindred subjects, by which we can all get each other's ideas and be mutually benefitted.



Therefore, if there are no objections, we will take up this subject, and anybody who wants to ask any questions or to give his experience or any idea, we hope will feel free to do so.

A delegate suggested that the President start the discussion by telling what he had accomplished at Pasadena.

MR. A. P. NOYES, of Vallejo. I would like to inquire as to the operation in the respective towns of those represented, of the street law, and whether it is more desirable to omit all reference in our freeholders charters to the subject and operate under the general law of the State, or whether anybody has had a successful experience under a local street law as provided in their charter. We have had a very unsuccessful experience in Vallejo, and have to carry out all our work by private contract, which, of course, has a great many drawbacks.

THE PRESIDENT. I doubt if there is any city in the State under a special charter which works under a local law on the subject. Pasadena is now adopting such a law, or will very shortly, patterned a good deal after the Vrooman act, taking its best features and leaving out its worst. It will take time to tell how it will work out. But we feel that it will be an improvement.

MR. NOYES. We have a Board of Freeholders in session now, drafting a new charter, and we want to find out whether it would be better to depend on the general law.

THE PRESIDENT. I think it would be well to put in the charter a provision giving the Council the power to pass an ordinance for street work. You could have that power conferred, whether you use it or not.

MR. HAMILTON, of Riverside. Speaking on that subject I might say that Riverside is working under a special charter, but we are doing all our work under the so-called Vrooman act, and prefer it in place of private contracts. But, under our charter, we have a provision which enables the city to exercise full authority in case we think there is any combination formed to make the prices too high. Thus far, we have not tried it, and do not know whether it would be successful, or not. That is the only feature that we have in our charter that has reference to this subject.

MR. E. P. WARREN, of Covina. Is there anything to prevent a city bidding, without that clause in the charter? Is there anything to prevent it bidding and thus doing its own work, the same as it would do anything else?

MR. H. D. CHAPMAN, of Richmond. The Vrooman act specifically provides that property owners can take the work up, but I don't think there is any clause in the law that will let the city be a bidder. The city of Richmond has a charter which has been said to be a very good charter for the smaller towns. We have a special clause in our charter that allows us to frame a special law on the subject, but we have never acted under it. We have always used the Vrooman act. But, as to the other question, we never understood that the city could bid on work. That is our interpretation of the Vrooman act.

A DELEGATE. The general understanding is that any city has only the powers that are delegated to it. If the charter does not provide that the city can bid, that settles it.

MR. JOHN CZERNY of Merced. Mr. Chairman, it seems to me the discussion is assuming a purely legal aspect, something that our section has nothing whatever to do with. We have a very efficient City Attorney, who looks out for those matters. I came here to study street work from the practical end, and I think it would be better to have the discussion confined entirely to that phase of

it. I would like to know something about asphalt macadam and oil macadam, and such things as that.

MR. C. H. PIEPER, of San Jose. I suggest that, in order to get something before us, that we ask Mr. Beyer, who has been very successful in that class of construction, to give us a brief outline of the manner in which they do work in Pasadena. I think that will open the subject up so that we can ask questions and probably get some new ideas.

MR. JOHN BEYER, of Pasadena. I would say that we have done considerable oil macadam work in Pasadena, and it has been fairly successful. Our specifications are embodied in the notice of intention, where we specify how the work is to be done. The thickness of the base, for instance, is controlled by the resolution of intention. The way we do is this: we first bring our sub-grade to grade, roll it thoroughly, and put on the base. We know from experience that the base will roll down about 35 per cent. Then, if a 7-inch pavement is to be made, we fill it with a base clear to the top of the 6 inch space, knowing it will roll down as I stated about 35 per cent, which will allow for your No. 2 rock and your finish. While the base is being rolled, we have screenings at hand up to an inch and a quarter size, and as the rolling progresses, the screenings are thrown on the surface to fill all the voids and make it as dense as possible; however, not so dense that it would make a finished street when the oil is applied, because we still calculate that we want to make it one homogeneous mass, so the second course will readily unite with this base rock. We then apply three-quarters of a gallon of oil per square yard to the base after the first rolling has been done before the second capping goes on. It is rolled again after the oil is applied, and then you put on your Number 2 rock, being from three-quarters of an inch to an inch-and-a-quarter in size, after which you run over it with a grader; we grade it perfectly, so as to get a smooth surface, then we apply this three quarters of a gallon of oil to the square yard. It is again rolled when the finished top of three-quarters of an inch, is put on, and then gone over with the grader again to true up the street. If you have a competent man on your grader, he can make almost as true a surface of the street as the board run through a planer in a mill. Then we put on a quarter of a gallon of oil—(that is what our specifications call for, but I find it is not enough—you ought to use three-eighths of a gallon for a finish) and add screenings, after which it is again rolled. The street is now ready for traffic.

We have had very good success in building our roads in that way. In the outlying districts we build a lighter pavement. Our present specifications call for one inch of broken stone, put on the roadway; then we bring it to sub-grade, except if the street is rough, and it nearly always is, in which case we plow and regrade. We put the roadway in shape for the contractor, and then he puts on half a gallon of oil to the square yard, followed by an inch of rock and a gallon of oil with screenings; after which he rolls it down. We have put down a number of miles of that street, and it has given very good satisfaction in the outlying districts where there is not a great deal of travel.

PROFESSOR HYDE. Do you roll the sub-grade?

MR. BEYER. Always. We never put stone on any sub grade, unless it has been first perfectly rolled, trued up and smoothed.

PROFESSOR HYDE. Do you roll it before the oil which is put on to the first course is applied?

MR. BEYER. Oh, yes, always roll it perfectly smooth before the oil is put on. The reason is, that we use screened gravel or broken stone, because either can be readily rolled into the surface and avoid creeping. Just now we are

adopting a new specification, which will provide for two inches of broken stone, and eliminate the round rock altogether—put on the two layers, and it is supposed to be graded so as to get a smooth surface, the same as we do in our heavier pavements.

PROF. HYDE. Is the oil furnished under certain specifications?

MR. BEYER. The oil is in every case furnished by the contractor. The oil is all tested in the laboratory.

MR. PIEPER. Do you use water with the oil?

MR. BEYER. Yes. We sprinkle the oil, more perhaps, so that we can get right into it with the roller, without picking it up at all. I think it also has a tendency to spread oil throughout the base. At any rate, we can go right onto the base with a wagon without the oil sticking to the roller, and that gives us a chance to put on the succeeding layers and run our roller without trouble.

MR. JENSEN, of Fresno. What kind of rock do you use?

MR. BEYER. Simply ground up boulders, which we obtain right in the vicinity there.

MR. JENSEN. Would you consider this a good pavement for a business street where there is heavy traffic?

MR. BEYER. I would say that we put it down on one of our streets where there was considerable heavy traffic. The Christian Science Church was afterwards built on that street, and I went to the trouble to find out just how much traffic went over it during its erection. I found that 8,500 tons of material went into one driveway in that street at that time, and it did not leave a wheelmark on the street anywhere. That part of the street is just as good now as any other portion. There is no doubt in my mind that there are loads going over that street amounting to three or four tons on one set of wheels.

MR. JENSEN. That pavement has been down about three years?

MR. BEYER. I think it is four years, but I would not be positive now.

MR. JENSEN. And the cost of repair to date?

MR. BEYER. Absolutely nothing.

A DELEGATE. Is this that on a 6-inch base?

MR. BEYER. Yes.

THE DELEGATE. What have you got with a 2 inch base?

MR. BEYER. We haven't put down any 2 inch base. We put in a 1-inch base in the outlying districts where it is not subject to any heavy traffic at all.

MR. PIEPER. How much oil do you say you use on your 6-inch work, in all?

MR. BEYER.  $1\frac{3}{4}$  gallons. There is  $\frac{3}{4}$  of a gallon on the base, and  $\frac{3}{4}$  of a gallon on the second layer, and  $\frac{1}{4}$  gallon on the third, but, as I said, we usually apply a little bit more than  $\frac{1}{4}$  of a gallon on the finish.

MR. PEIPER. Is it not a fact that the amount of oil is a very important feature in that kind of work and that you are apt to get on too much?

MR. BEYER. That is very often the case. On this very street that I speak of, the property owners insisted on our using more oil. The contractor had already put on all the specifications called for, but they thought if a little oil was good, more oil was better. The contractor was willing to put it on, because he didn't want to make his bills any harder to collect than he could help. I allowed him to do it, but told him to keep his oil good and hot and leave as little oil on the street as possible. He did so, and in less than two weeks it required more sand, and in two or three weeks I had to have my grader blade ground perfectly sharp, and shave off some of the oil.



MR. PIEPER. Why does this work stand any better than petrolithic work?

MR. BEYER. I can cite you a case as a reason why I think it is better. We have one street that we oiled with surface oiling at one time with  $1\frac{1}{2}$  gallons of oil, and it was done in the fall of the year. The winter rains came on before the street got perfectly dry and we had an oil mud there of two or three inches deep, the nastiest mud that anybody ever saw. In order to fix it up, I put on about two inches of crushed rock, and worked it into the oil, finally using screenings enough to dry it up. After a while, however, that street got humpy and wavy, and we bought one of the petrolithic road rooters, and rooted that street up and got the rock down under the oil, or the oil up over the rock, and we have never had any further trouble with it. My theory is that the rock laid on top of the oil and therefore didn't rest on a solid foundation; that is why it went uneven. I don't know why we should tamp oil below macadam. I think that if you put oil and dirt together and tamp it down, you would only increase the softness of your subgrade.

MR. PIEPER. It makes it spongy?

MR. BEYER. It makes it spongy, and your rock will lie on that sponge, and it is not good. I think the petrolithic tamper is all right, but it should be used in the base.

MR. PIEPER. Merely as a roller to roll the base?

MR. BEYER. If you can roll it any harder with a tamping roller than with a smooth roller, I would advise its use.

MR. DARLING, of Riverside. What advantage is gained by mixing the oil with the rock?

MR. BEYER. Well, in one case we got our rock from the San Gabriel River. A large portion of it was either entirely round or consisted of small stones broken in two and not angular on two sides, and although we graded and smoothed the street and rolled it, the more work we did on it, the worse it seemed to get. I advised the contractor to put on a coat of oil, which he did, using about a gallon to the square yard. We then held our stone in place perfectly, tamped it up with the grader, and it didn't creep at all, staying right where we put it, and it is one of the best streets we have today.

MR. PIEPER. What does the 6-inch work cost you?

MR. BEYER. 10 cents a square foot.

MR. PIEPER. And what do you pay for your rock?

MR. BEYER. The rock is costing, delivered on the street, \$1.90—it comes from San Gabriel, as I said.

MR. PIEPER. \$1.90 a yard or a ton?

MR. BEYER. A yard.

A DELEGATE. And what does the 2-inch work cost you?

MR. BEYER. That is a specification under which we have not worked as yet, but it will be used in the outlying districts. I would think it would cost us something like three cents a square foot. For one inch of rock, we have been paying  $1\frac{3}{4}$  cents a square foot.

MR. JENSEN. I would like to ask Mr. Beyer what gravity of oil is used in that work.

MR. BEYER. I think our specifications call for 10 to 11 gravity, and it shall carry not less than 75 per cent of asphalt.

MR. VAN ORNUM. While we are on the subject of oil, I would like to add a few remarks. The pavement depends a great deal upon the oil, necessarily, which is the binding medium, and we should of course get the best oil obtainable.

Years ago, there was a great deal of oil in the Bakersfield district and Sunset district which had laid out in the open for several seasons, and had pretty nearly distilled by nature—that is, the hot suns of Summer distilled the light oils. That was very fine road oil. That road oil ran from 75 to 80 per cent of asphaltum. That oil is practically used up at the present time and you can obtain very little of it. The result is that the oil now being used is topped oil—the light oils (the gasoline, benzine, and also part of the lubricating oils) have been taken off, and the great difficulty now is to see that the asphaltum oil has not been harmed by overheating. So now in our specifications we do not require a crude asphaltic oil as we did formerly when we could get this Sunset product. Now we require an asphalt oil which contains 80 per cent asphaltum at 77 degrees temperature and which shall not contain more than 2 per cent of water and sediment; the oil shall not contain more than 2 per cent of sulphur. The residuum, after being run down at 400 degrees Fahrenheit, shall not contain more than 2½ per cent sulphur, District of Columbia standard, at a penetration of 80 degrees, and shall be soluble in carbon tetra-chloride to the extent of 99.8 per cent. We do not want an oil that is the product of too much heat in distilling. It is very important to see that we get good road oil for our oiled macadam streets, and anybody who is using oils, if he has not a laboratory at his disposal, should make some arrangement to have the oil properly tested.

MR. JENSEN. Do you know how many cities in the State are using oil macadam?

MR. VAN ORNUM. I think the city of Riverside is using it very extensively. How many miles have you?

MR. DARLING, of Riverside. About 60 miles.

MR. VAN ORNUM. I have been over those roads in Riverside, and they are in excellent condition—thoroughly satisfactory. Pasadena has contracts now for the construction of five or six miles. The city of Los Angeles has adopted oil macadam specifications for their outside streets. The city of Sacramento is constructing oil macadam streets, and also Alameda and also Stockton. That is as far as my information goes. Is there any other city that is represented here that is constructing oil macadam pavements?

MR.-CHAPMAN, of Richmond. Richmond is.

MR. VAN ORNUM. Mr. Campbell of Riverside, has done a great deal of oil macadam work. He has studied the problem, and I think he could give us some very good pointers, especially as he constructed some work, I understand, where only the surface has been treated with oil, after the street has been first constructed as a straight macadam street.

MR. JENSEN. And I would like to ask Mr. Campbell how long those streets have been laid, and at what cost.

MR. CAMPBELL, of Riverside. I think I will have to give you a little bit of history, in order that you may appreciate what we have done in Riverside. Our first extensive macadam pavement was first put down in 1896. It was a strip of light stone macadam, 20 feet wide, 6 inches in depth, and as soon as it was finished, we had to start sprinkling the street. There was some 7½ miles of it constructed for the main artery. There was always either a little surface mud on those streets, or dust, one of the two. That continued until about 1903, when we tried a little oil on a piece of it. It worked very nicely, and when we got hold of the Sunset oil, which was heavy oil, as Mr. Van Ornum has said, about 10½ gravity, we swept all those streets very carefully and went over them with oil, using a gallon of oil to the square yard and leaving the street right down to a

hard basis, with no dust patches or any thing of the kind. After putting on that amount of oil, we spread it over with screenings from the quarry; not screenings without any dust, but just as it would naturally come without specifying the size, probably not to exceed half an inch in size. That immediately rolled right down to a carpet and practically we have done nothing since to those streets, with possibly some exceptions in different portions. Some of it has not been touched at all, and to other portions we have sent a surfacing man over it and filled in small defects. We have, of course, had to have the pavement cut in a number of places, and my judgment would be that that 6 inch pavement, by the time we put on the oil, had worn down to less than 4 inches. But at the present time there has been no wear on the macadam itself since the oiling—the wear has come on the oil. Perhaps in one or two places we have had to send a patching crew around where the oil has worn off. That gave us a clue as to how to work in the future. Our next set of streets were constructed of 4 inches of macadam and two inches of decomposed granite on top of it. We took those streets, and put oil onto the surface, dusted them over with screenings again, bringing it up from 2 inches to possibly  $2\frac{1}{2}$  inches or 3 on top. Those streets worked nicely, but they kept buckling on us, going into waves. So we invented a machine to cut those waves off, and filled up the hollows. Up to the present time that form of street has given us the most trouble. It showed that we required just as little top surface as we could get, that the oil should be right next to the hard macadam base. All our late streets, those built within the last four years, have been constructed with oil right on the macadam, and perhaps that little finishing coat of oil next to the macadam does not exceed  $\frac{3}{4}$  of an inch in thickness. To speak about macadam as we construct it today, I would say that we probably construct it in the ordinary method, and when we come to the last course, after we have filled it in the ordinary way, we bind it. We do not put excess of binder on top, but rather keep the surface of macadam so that you can just see the binder; as if the street had been pounded. Then we put on probably about half a gallon of oil to the square yard; we dust that with limestone screenings and smooth it over. Then we come back again with the remaining half gallon of oil, put screenings on that, and smooth and roll it some. Such a street, when first done, is rather tender and will show up a little excess oil in some places and not enough in others, but we send a man there, and where he finds an excess of screenings, he will push them over onto the oil. After a while, the whole surface dries down so that it looks like an asphalt pavement. That class of streets have had practically no repair, while the streets that we have had to repair, as I say, are the ones on which we had an excessive thickness of oil coat over the macadam. That is where we used two inches of decomposed granite, which was practically sand at best, and added another inch by putting on the topping. All of our streets treated in that way buckled and went into waves. While I am on my feet, I want to call attention to the fact that the oil macadam used in Riverside is entirely the surface method, not having the oil all the way through. The oil goes down somewhat. We have taken up samples which have shown us that it penetrates an inch and a half, anyway, downward, as well as going upward. I believe that explains about what we are doing.

MR. M. C. POLK, of Chico. May I ask about what is the average cost of that pavement?

MR. CAMPBELL. We are paying, under the Vrooman act, about 6 cents a square foot for the 4-inch macadam, and our 6-inch macadam varies from 8 to  $8\frac{1}{2}$  cents—I don't think that any of our contracts have exceeded  $8\frac{1}{2}$  cents, and most



of the work ranges between 7 and 8 cents. I will add that our macadam is not of a uniform thickness. We speak of a 4-inch macadam, meaning that it will be 5 inches in the centre and 3 inches on the sides. A 5-inch macadam pavement is 6 inches in the middle and 4 inches on the side, while a 6-inch pavement is 7 inches in the middle and 5 inches on the side. Where we have a very narrow street, we put it uniformly 4 or 5 or 6 inches, but the rule is as I have just stated.

MR. R. LATHROP of San Bernardino. I would like to ask Mr. Campbell what class of material or rock he uses for making macadam.

MR. CAMPBELL. We have two sources of supply there at present, our own city quarry, which furnishes rough granite and makes a satisfactory street, and then we have furnished to us a limestone, from which we are making our roads entirely at the present time.

MR. LATHROP. The screenings?

MR. CAMPBELL. The base, screenings, and the whole thing. But we have some good streets made of our own material, which is granite, as I say, and we can see no difference except that probably you have all noted that when you have taken oil and tried to mix it with rock, limestone seems to have a better affinity for oil than sand. We consider that sand is the poorest stuff you can mix with oil, and limestone is the best, while granite screenings are in between.

PROF. HYDE. Are you using this construction on the streets carrying the heaviest traffic, or have you adopted some other type of pavement there?

MR. CAMPBELL. Probably our heaviest traffic streets are those over which produce is brought in from the country, big loads of grain and hay, and on those we have a 6-inch macadam, of which the city quarry granite is the base. I will state that there is another thing we have observed in doing this work, and that is that the size of the rock makes a difference. You bring in a load of small rock, especially if the granite is not very hard, and the roller will crush it down too much. On the streets with the heavier traffic, instead of using the ordinary  $2\frac{1}{2}$ , we use  $3\frac{1}{2}$  inch rock, and we find it is superior to the smaller rock.

MR. PIEPER. Do you use special run or straight stuff?

MR. CAMPBELL. We do not use it all of one size. We specify that we want from 2 to 3-inches, meaning a rock that will run from  $1\frac{1}{2}$  inches to  $3\frac{1}{2}$  inches.

MR. PIEPER. Then you roll that and put on half a gallon of oil.

MR. CAMPBELL. Yes, and then the screenings and then more oil.

MR. PIEPER. Any water?

MR. CAMPBELL. In making the road in the first instance, we get it to sub-grade and roll it; and, if necessary, cross-roll it, and irrigate it and get the sub-base so that it is so hard that there will be very little give to it whatever, that is, no soft spots; and then we put on the rock, usually one course of rock, and after we have rolled that so that it is well together and stands up in pretty good shape, we bring on fine screenings and keep the roller moving up and down and with steel brooms brush those screenings into the macadam, filling it practically full of screenings, using a little water, but not too much.

MR. PIEPER. But you do not put the water on top of the oil?

MR. CAMPBELL. We do not use any water in connection with the oil whatever—that is, the surface is perfectly dry before the oil is put on. Referring again to the kind of rock, I will say that in all our work we prefer a rock that has good bearing qualities and sufficient strength, but we do not care about a rock so hard that it won't stand compression. You take a rock that is too hard, and wheels going over it will abrade it too much. If we had never had the oil, we would never have put down another limestone street, because the wheels would

abrade it so much. But, since our wheels no longer travel on the macadam direct, but on the carpet, a comparatively soft rock will answer, and we are inclined to take the rock that goes out about 2.70 gravity and fairly soft. And we do not want it to vary in its softness, a lot that will break up very easily, and one that will not. We remedy the very soft rock by taking it in larger sizes.

MR. BEYER. While it is not absolutely necessary to pave the street in hard rock, do you not think a good macadam road could be constructed out of basalt rock or trap rock?

MR. CAMPBELL. We believe a tough rock could be used. But our experience with hard rock has been rather disastrous to us. We have had a rock that was hard but brittle and smooth—would not bind together at all and would crack up like glass. That kind of rock we want to avoid. Some rock we get so hard that, to put it on the street, it will roll every way and run off the edges, but won't cinch down. That we don't want. Another thing, too. You take these hard rocks, and you are buying more in weight than is necessary, that is, rocks that come up to 3, 3.1 and 3.2 for specific gravity, as against 2.7 for a softer rock. If the rock is hard enough to bear up the load, we do not see any advantage, as long as the wheels do not travel on it, in getting an excessively hard rock.

Mr. LATHROP of San Bernardino. I would like to ask Mr. Campbell if he thinks that limestone screenings have any cementing qualities, if they do not cement the bond together more than granite screenings?

MR. CAMPBELL. I can say by way of reply that we have a piece of this limestone pavement that we put down in 1896. We since had occasion to dig some up and you would think it was a piece of concrete in which they had used white cement. It was one solid mass. You could not tell where the joints went together, because they had been so thoroughly cemented. I was surprised at it myself, but that is a fact.

MR. LATHROP. That would indicate that there were cementing qualities in the screenings?

MR. CAMPBELL. Yes, I believe there are. Of course, there is supposed to be a little cement value in all the rocks, but I consider that the limestone has a little more of it than where hard rock is used.

MR. WAGGONER, of Burlingame. I would like to ask Mr. Campbell if it makes any difference whether you have adobe ground or sandy ground?

MR. CAMPBELL. Where you have adobe ground, if the mixture is not just right in it, you will have a hard time rolling it. In sandy ground, the same thing will happen. We have an adobe soil all through, but it runs almost straight adobe, and in some cases we have a whole lot of trouble in getting the sub-base and packing it. But usually we can get it by watching carefully for the mixture that is in the soil. If it rolls in streaks, we may wait a while and recultivate it over, and get a little bit of moisture in that, and then it will pack down all right; probably most of our trouble has come from a too sandy rather than a soil with too much adobe in it. I think Mr. Darling can answer that better than I, because he is right there on the work, and knows just exactly what is best to do.

MR. DARLING. We have had very little sandy soil to contend with in Rverside. Adobe soil works all right under the roller, if you have the right degree of moisture. If it is too wet we have considerable trouble, and it gets spongy. But we aim not to have it get too wet. Of course, we do not work on it in the winter. We irrigate and sprinkle, and get as near the right degree of moisture as we can before we put the roller on, and then we have no trouble whatever about

getting the right kind of sub-grade. It goes down hard and compact, and we get just what we want.

MR. BEYER. Possibly I can answer the gentleman's question regarding the sand foundation. I was in Spokane, Washington, last spring, and they wanted to build a piece of oil macadam road there. It was in a soil of sand and volcanic ash. We ran the waterwagon over it back and forth for three or four hundred feet and thoroughly wet it before we could roll it at all, and then we went to work and rolled it solid. It was sand, but while it was wet, we could get a roller over it without difficulty: We had one 12-ton roller and one 6-ton roller. The 6-ton roller would not go at all—the wheels would just slip in the sand. But the 12-ton roller worked all right. After putting on 5 inches of rock and rolling it, we got a splendid roadway. To be sure, the rock would roll into the sand, and the sand would come right up into the base and fill up at least one-half of the base. But I do not think there is any trouble about constructing a good road on sand.

MR. R. G. THOMPSON, of Santa Ana. I would like to get some information on a kind of pavement that we are putting down in Santa Anna. It is a mixture somewhere between the petrolithic and rock macadam. The method, as I understand, used in building this kind of a street, is, to excavate down to the subgrade, put on the amount of rock they are going to use, and then they tear it all up with these rooters, saturate it with water and oil, and then tamp it with the petrolithic tampers, until they get it solid; then I think they roll it with a smooth roller and finally apply the gravel or broken rock, whatever it is. We use gravel there because we have plenty of it, screened gravel. When they put on the gravel, they go over it and oil it thoroughly, and I think perhaps put a little more water on; then they mix it all up with the dirt and then put on the tampers and tamp it down and roll it and then finish the top with oil and screenings, as is usually done in finishing rock macadam. It is a new thing with us, and I would like to know if any other city has had experience with that exact sort of street. We feel a little dubious about it.

MR. NOYES of Vallejo. I think Vallejo has had a little experience in that direction. We came down south and investigated the matter, and we have put in probably thirty or forty blocks in our city. I believe our mistake was that we expected too much of it. We tried to put it down on our streets having heavy traffic, and under heavy traffic a dirt and sand pavement will not take the place of a 25-cent pavement. On the residence streets it works better. On account of the heavy winters that we have, and the large amount of adobe soil, we found that on our streets of heavy traffic during the past Summer we needed to cover over nearly thirty blocks of the petrolithic pavement with three inches of bitumized concrete where there are grades of over 4 per cent, and where the streets are level, we have put 1 ½ inches of the same material. In that way, we have an excellent system of streets for rather a small amount of money. We have found in every case that the petrolithic pavement has given us a first-class foundation, but that it was necessary to save our foundation by covering it with some permanent pavement. But I still believe that, for residence streets, where the traffic is light, delivery wagons and other light traffic, a very excellent street can be made by the petrolithic process, even in northern California.

MR. DUPUY of South Pasadena. A little over a year ago, we put down streets similar to the streets being put down in Santa Ana. I was at Santa Ana about a month ago, and looked at the work that is being done there. We thoroughly tamped our sub-base, and on the streets I have reference to, the soil



was rather a gravelly soil. In one place they turned up gravel all the way up to as large as your head. Of course, we picked out gravel stones of that size. We thoroughly tamped the sub-base with the petrolithic tamper, and put  $2\frac{1}{2}$  inches of screened gravel, which is similar to crushed rock, gravel  $2\frac{1}{2}$  inches in diameter, which we got from the arroyo and which was very hard granite and rather round—not angular gravel at all. We put that on the streets, rolled it with the petrolithic rollers, and thoroughly mixed it with the material that formed the subgrade, which was a sandy gravel, and then put our oil on that, and continued rolling it, with a great deal of water to thoroughly saturate the mass, so as to keep it wet while the roller was at work. We rolled it with the tamper until the tamper would not make any indentation on it at all, and then  $2\frac{1}{2}$  gallons of oil was added—two gallons in the sub base, and then screenings were put on those, and half a gallon of oil on the screenings. That street has had considerable heavy traffic over it, has been down over a year, and it is in perfect condition. The surface is perfectly smooth and hard, and a person would not want a better street than that. We have also tried the petrolithic streets on the natural soil, and that has not been satisfactory; the streets that we have put down with a petrolithic pavement on the natural soil, without putting gravel or crushed rock upon it, have been soft and wavy, and, under the travel, they have risen up and not proved satisfactory.

MR. LATHROP of San Bernardino. In San Bernardino, I had charge of the construction of about eight blocks of what is called petrolithic pavement, 3 inches rock on the surface. That has been down about three or four months, and at the present time it has the appearance of being a very good street. But if we had not been able to obtain a gravel rock on adobe, I think it would not have proved successful. I think the gentleman from Vallejo can expect a more successful street in a town where the temperature is as it is in Vallejo, with oil on top, than would we in San Bernardino and southern California towns where the temperature sometimes gets above a hundred. I notice that in all of our streets where there is oil on top, it is more successful when the thermometer ranges down between 70 and 80, than it is when it reaches 110. I understand that there are quite a number of people here who are going to have streets constructed. We people in California, during the last three to ten years have been constructing streets, and have been doing more or less experimenting. Nearly every town has spent a good deal of money in these experiments. It would appear to me that there should be some place in California where the experiments, and especially the successful ones, could be put through what you might call a clearing house, and somebody would be able to tell people about to enter upon street construction what will be the best for them to do. It makes a difference about the class of material that you have. In Riverside, they construct I presume as fine streets as there are in the country, and they make it of limestone rock, because they have the limestone right there. Pasadena has excellent streets, but they are not made of limestone. The surface material, the natural face, makes a difference about the street. The amount of oil you put on under the varying conditions makes a difference. It seems to me that it would be a good plan for the State of California, like some of the other States, such as the States of New York, Massachusetts and Michigan, to have what is called a Highway Commission, and the people of any of our California towns could then go to that Commission and ascertain accurately the facts, and we would not have to be experimenting and paying out money and looking up matters all the time.

MR. DARLING. It has been said that Riverside uses limestone rock in the

construction of its streets. We use it because we consider it is the best rock that is available. I do not object to using a harder rock, providing it has got binding qualities. But we have some of the hardest rock and find it too hard to bind. It is for that reason that we have adopted the use of the lime rock. We do consider that it makes a first-class street. I want to add one thing to what Mr. Campbell has said in regard to street construction, and that is concerning the use of the roller. We start in with the sub-grade, and we do not spare the rolling until it is in a proper condition; that is, we continue it until it is absolutely solid and unyielding, and after the rock is put on, we roll the rock until the rock itself is thoroughly bound before we use any filler—he has spoken of that filler and called it a binder. In the work that I have had under my charge, I have seen to it that the rock is thoroughly bound before there is any filler put into it. In other words we bind the rock first, and then we use the filler to seal it—we use limestone and fine limedust, and roll as much of that into the rock as we can before we put on any water, and then the water has a tendency to slake and set that, and make a perfect bond.

MR. PIEPER. Any oil with the water, or vice versa?

MR. DARLING. We do not believe in using any oil except on the surface; and do not mix any with our rock at all.

MR. CLOCK of Redlands. Has any city here had any comparative experience with the petrolithic and macadam pavements? I understand there is not very much difference in price of a 5 inch macadam and petrolithic, and if the macadam is better, why not put in the macadam—it can be torn up so easily and oiled and sanded and made as good as at the start. I would like to have some ideas in that regard, to take home with me.

MR. VAN ORNUM. In regard to the petrolithic pavement, I will say that I have not seen any petrolithic pavement which is perfectly uniform the full length of the street! A slight variation in the character of the soil or some condition of the soil will produce a different surface. I have seen streets where, in one spot, it would be very spongy, very soft, and right next to it you will have a beautiful surface, one which closely resembles the sheet asphalt. That is one trouble that I have found with the petrolithic pavement, that you do not get uniform results. That is also somewhat true of the oil macadam. Particular pains are not taken in screening the different sizes of rock. The rock should be screened into different sizes, and pains must be taken in spreading the rock on the surface, to see that the macadam has not too much screenings put on at one place and then been left open in another. Where you have too much screenings, the oil comes to the surface and you will have a spongy spot, and where the macadam is open on the base, the oil will go down and you will have a deficiency of oil on the surface. I think that oil macadam has its place in street paving. It is not adapted for heavy traffic streets any more than a sheet asphalt street in New York or Chicago on the heavy traffic streets. But for the residence streets in the ordinary city, oil macadam will make a thoroughly satisfactory street. It is dustless in the summer, not producing as much dust as does sheet asphalt, since a certain amount of the dust is absorbed by the oil. It is not as noisy as the hard pavement. It has those two excellent qualities for a residence street. Another thing which the delegate from the northern part of the State should specially take into consideration is that there are ideal conditions in Southern California for this class of pavement. We have a dry climate here, our soil generally is excellent, subdrainage is good, and we have very little moisture. So a light pavement that would be satisfactory in Southern California would not stand in the north. And I would warn the dele-

gates from the north that when they hear the pavements of Southern California spoken of, to understand that it is necessary to make heavier macadam streets in the northern part of the State than we have here, and also, never to construct an oil macadam street where there is heavy traffic, as the pavement would not stand it there as well as in the south.

MR. GARRARD, of Richmond. I am an employee of the Standard Oil Works in our city, where we have lots of oil. We have made some very extensive experiments in oil macadam throughout the grounds and works. A few years ago we did some oil macadam work, and having lots of oil, they put on plenty of it, not measuring it at all. Then they put on the screenings. It was found that that was a terrible mistake. It made a regular mush, and would not settle at all; it has not settled yet, and sticks up in one place and down in another. Their first experiment not being successful, they next put down a piece of regular macadam, and oiled it and watered it, after which they rolled it and let it lay. Then they went over it and applied another small coat of oil and let it lay quite a while. It was done in the summertime, and finally they rolled it again and then opened it for traffic. That street has so far been very good, although it has not been used long enough to tell exactly how it will turn out, since it was only put down this summer. But they had a good base of hard rock to bond naturally though the oil seemed to bond it very well. In fact, it now is well bonded apparently. Then they went on, and in another piece of about 300 feet, they put down 3 inches of rock, and then rolled it and oiled it. Then on top of that, they put  $2\frac{1}{2}$  inches of No. 3 or inch rock, which they oiled and then finished up with screenings. If anyone were to examine that without making too close an inspection they would think it an asphalt street. They found that it was a mistake to use too heavy a roller on the finish as a light roller would bind and not break the bond—it appeared, as it passed over it, to merely tie it together. That street has very heavy traffic over it; I don't think there is any city street that has much worse traffic—heavy loads, with rocks hauled from the quarry, and narrow-tired vehicles at that. Yet it has apparently not been affected at all by wear thus far. In the city itself, we have done a great deal of oil macadam work this last Summer, but they do not use the same method, and contractors do not seem to understand exactly or do not want to, I do not know which. At any rate, we do not get as good satisfaction in our oil macadam streets as we should, in the city. I examined the streets at Stockton last Winter, and find they have some very fine oil macadam roads there. I believe our roads in Richmond will turn out all right later on. But at the present time they do not look as nice and smooth as the roads of Stockton. Another thing. We have a little machine called a slicker, which is a fine thing to smooth out a road, and prepare it for a roller. It is about ten feet long, made of half-inch boiler plate; the back end of it, called the shoe, is about two feet wide, and runs on the ground. In front there is a blade that cuts off any ridges and smooths them down, and I believe that is the principal reason why we obtain such smooth surfaces. It is a very cheap little machine—any boiler shop could build one, as we made ours. With such a machine, which can be easily adjusted, if you want to shove your rock off to one side, you merely slip the chain, and thus are enabled to move the rock around in any way you desire. It is also useful to spread the rock around in any way you desire. It is also useful to spread the rock and make a flat surface of it after it is dumped. In conclusion, I would like to impress the fact that one of the worst features of all, is to get too much oil. Be careful and do not use too much. There is another point. We find it a great mistake not to get the oil on evenly. You take the common, ordinary sprinkler, and perhaps you



will get a gallon on this yard and a gallon and a half on the next yard. We put ours on with a large, special sprinkling apparatus, with the oil very hot. We put a straight edge along on the street, and as the can holds just so much, if they go along at a steady gait, they get it on very evenly. The straight edge is set every three feet, and we do that three feet before we take the next one—all by hand. The results obtained in this way seem to be very good. I think it is a very important point, too, if you use a sprinkler, to have one that will put it on absolutely even. I am inclined to think that the failure in oil macadam roads is in great measure due to the fact that the oil is not put on exactly even. There is one other point I forgot to note, in reference to our last experiment. In this case the oil was put upon a 2½ inch top layer, and after it lay for a while, they plowed it with a disk plow and thoroughly turned it over, so that instead of the oil being on the top and sides of the stones only, with probably the under side not having any oil at all, by this method the stones were enveloped in oil. It appears to be a very good plan. The plowing is very simple.

A DELEGATE. What kind of oil do you use?

MR. GARRARD. We use 10½ gravity oil, after the refined products are taken out of it, the gasoline and such things.

MR. BEYER. I believe, Mr. Chairman, that at our last year's convention there was a committee appointed on specifications in regard to this work. Does anybody know anything about that?

MR. PIEPER. I will say that I was one of that committee, though not the chairman. I must confess frankly that up to date I have not been able to even get an idea of what would be a proper thing to formulate as specifications to do work in every portion of this State, because, as your chairman has stated, conditions in the southern part of California are different from those in central and northern California. So I have simply been trying to study what might possibly be termed a general specification, thinking I would hear from Mr. Hudson, also the committee, but he is not here.

MR. VAN ORNUM. Mr. Hudson is now in the East. The former city engineer of Santa Barbara is on the committee also, and he has resigned. So there are two vacancies on the committee. I have understood that the committee never got together.

MR. PIEPER. That is correct, Mr. Chairman.

MR. VAN ORNUM. It seems to me that it is a pretty hard matter at this stage of our development to draw a standard set of specifications on oil macadam. I believe it would be well to continue this matter, and make appointments to fill the vacancies, and see what progress can be made during the coming year in drawing up standard specifications to be adopted for all conditions and all sections of the State.

MR. BEYER. I think Mr. Pieper has probably given it a good deal of thought during the year, and I would like to have his ideas.

MR. PIEPER. As just stated, I must confess that I have not any well-defined ideas upon the subject at all. We never have been able to construct anything up our way in the shape of an oiled road that is any account at all. Just a year ago officials of Santa Clara County thought they would experiment a little more with it. At one time the county did put in about 40 miles of oiled roads. They came down here to Southern California, (the county engineer and one of our supervisors) and they inspected the roads of Pasadena, Pomona, and other places. They came back very enthusiastic, with a full outfit of the Petrolithic Company's plans, and went to work. They took about a seven mile stretch, and started in,

having the aid of someone they got from southern California who they thought knew all about it. They tore up the road, oiled it, and put on, as they said, the requisite rock. As soon as that was open to travel, it balled up and rolled up and waved up, and, they added an inch of rock to begin with, and they kept on increasing it until finally on the lower end they added about seven inches of rock. They worked at it night and day, I think, for about six months, rolling and grading and shaving it off and trying to get it down. If you go there possibly right after they have been working at it, you will find a very fine road. But about a week later, you will find it in rolls and waves. Up to date it is pretty nearly a failure. I am satisfied of one thing, and that is that up there we should keep the oil out of the foundation, as otherwise it will result in a mushy foundation. And I don't care what you put on top, it is going to wave. So you must put down something that is going to stand as a foundation. I think one of the cardinal principals of roadbuilding is a solid foundation—you cannot roll it too much. The question of drainage did not affect the county road that we oiled. For that reason it seemed stranger that they did not get better results. But they have not been able as yet to make the work stand. As for the teamsters up our way, I think if they put down any more of that kind of road, the supervisors will be mobbed, for the teamsters won't haul over it. As an illustration, they haul rocks from the quarries, and the regular rock teams, to avoid three-quarters of a mile of that road, go around two and a half miles, in getting into San Jose, because they can't pull over it, but get stuck. For that reason, I say that I do not know what you could suggest as a general specification for this State. Probably if the committee had gotten together and talked the matter over and exchanged ideas, we could get something, and particularly would this be the fact if we could visit the different parts of the State where conditions differ. But you take a set of men from any other particular locality, and you cannot get those men to draw up specifications, to fit the State, unless they travel over the State. If you are going to appoint another committee, I think it would be well to distribute it around the State where they have different conditions and where they have experimented with this character of work under those different conditions, and in that way form some idea as to what is best.

MR. WARD, of Santa Ana. The matter of oil in the base of the road has not been very much discussed. I would like to know if there is any virtue in it, and if so, why.

MR. BEYER. I do not believe it is Mr. Pieper's idea that he would not put any oil in the base. It was the sub-grade and not the base that was soft in his case. Riverside does not oil the base at all—they only oil the surface of the base, and here is a gentleman that not only oiled his base, but then he turned the rocks over so as to be sure to get the entire surface of the rock oiled. With us, as I said before, we had a considerable quantity of round rock in our macadam, and we could not bind that round rock anywhere until we oiled it, and after we oiled it, it stood perfectly. We graded up the street, and we rolled it, and it never moved a bit—it was a perfect binder, notwithstanding many round surfaces. I think there is a great deal of trouble in getting oil under your base. There is no composition of two soft materials like dirt and oil, that you can mix together and roll down and get a hard foundation under your rock.

MR. WARD. That is just the point I wanted information on—should we have oil put on the dirt and then rock on top of that.

MR. BEYER. I don't see how there is anything made by putting oil on the

dirt under the sub-grade, for unless you can make your sub-grade hard, (and I don't think you can if you put oil on it) your road will not be a success.

MR. PIEPER. That is what I meant to express—don't get it down underneath the lower layer of rock. You have to get a foundation. Never put oil under your under layer of rock.

MR. GARRARD, of Richmond. I think I have been misunderstood. We find that it is a mistake to let the oil go down into the subgrade—that is where the emulsion that we suffered so much from in our first experiment arises. You can't hold it there—it will not stand still. It was the top part only that was plowed, and not the subgrade.

MR. NOYES, of Vallejo. I would like to ask some of the gentlemen who maintain this sort of surface, as to the expense of maintenance. How often do they have to re-surface the street? That question comes in in the comparison between the petrolithic and macadam streets. To my mind, if the surface could be maintained on a macadam street at a reasonable cost, there is no excuse for a petrolithic pavement. It would be much more economical to build a macadam road and keep it oiled properly. But that would depend upon how often the street has to be re-surfaced.

MR. DARLING. In answer to that I will say that we have one street put down about three years ago, it is about a 4-inch macadam, and has taken a pretty heavy travel from our quarry towards the city, and I don't think we have spent a dollar on that street for repairs, except where it has been dug up for trenches or something of that kind. I would like to get the idea of some street superintendents and engineers in regard to the size of the rocks used in an oil macadam street.

MR. R. C. TOMALTY, of Stockton. We use the ordinary rock that runs from  $2\frac{1}{2}$  inches to  $1\frac{1}{2}$  inches for the lower grades in Stockton, and the next course consists of rock that will pass through a  $1\frac{1}{2}$  inch ring, while the top course is what we call  $\frac{3}{4}$  inch rock, ranging in size from  $\frac{3}{4}$  of an inch to dust. We have good results in our macadam streets. - I want to say this about oiled streets. We put in forty two blocks of oiled streets over a gravel base. We used a pretty good kind of gravel for the purpose, one that cements very well, and we made our streets an average of seven inches in thickness, rolling the street in two layers and making it perfectly compact with nothing but a water bound gravel. When we finished them and got the surface thoroughly packed we oiled it with an application of half a gallon to the square yard. The oil is an asphaltic oil, that is, very rich in asphalt. I believe it runs as high as 80 per cent, a natural oil just as it comes from the ground, without being treated to any distillation whatever. On this oil we spread rock screenings (decomposed granite or broken concrete) and we found that the broken concrete gave us the very best results. We put just enough screenings on to take up the surface oil and no more. A few days later we treated the street to another half gallon of oil to the square yard of surface, and this was taken up as before. I believe these specifications are like those used in Riverside.

Our streets have been down for three years, and they have never cost us one cent for repairs. They have been subjected to two floods, and I have walked over the crown of one street in particular with gum boots on, and the water 18 inches high on the top of the street, but the water didn't seem to hurt it. In places, the oiled surface would rise up, but it did not crack, and after the flood subsided, the oil went right down to its level without cracking at all, and the pavement, although it has been down three years, is in good condition throughout. However, I think the most necessary thing about building an oiled street is to



make a foundation. If you can't make a good foundation, there is no use in trying to build an oiled street. The trouble about oil has been because many people have thought that if they merely put oil on the street, all their difficulties are over, and that it is a panacea for all the ills of street making. But that is not right at all. Oil is only useful for two or three things: It is useful to make a surface that will shut out the water, for one thing; it presents an excellent surface, for another thing, because it does not grind up and cause dust, and it gives you a dustless surface. Those are about the principal advantages you get from the use of oil. If you decide to take a pavement and bind it with oil all the way through you are apt to find out that you will spoil it. Another thing: if you put an oil conduit on a street that has a good foundation, you will not have any waves. If you will come up to Stockton. I will give you a twenty dollar gold piece if you find one wave in the twenty-two blocks, and you can't say that for an asphalt pavement. And the thickness of the coating is from  $\frac{1}{2}$  an inch to 2 inches, but the coating is rolled down to the  $\frac{1}{2}$  inch carpet. We tried to put it down thin, and the contractor was told to cut down the quantity for that purpose.

MR. WARNER, of Covina. How much trouble have the engineers had with their new oil macadam streets with the surface dressing slipping off within a few weeks of its application? We have about a mile, I think, down, and there are portions of it that are beginning to be affected in that way.

MR. DARLING. We have had no trouble of that kind. Our surface seems to stick all right, and we do not have any trouble whatever in that respect. I would like to ask the gentleman what quality of oil he uses, and what he uses as a covering for his oil, to place it? There may be some difficulty there.

MR. WARNER. This street was put down under contract, and I could not remember the specifications. I am not the engineer or the street superintendent, but we followed very closely the specifications that we secured from the Pasadena city engineer's office, and put down a 4-inch macadam.

MR. CHAPMAN, of Richmond. We laid out a street in Richmond, an oiled street, and heavily laden teams would turn around a curve from the street, going off the oiled pavement, and we found that the street at that point raveled very rapidly. We did absolutely nothing to that street, and under the ordinary traffic after the wagons had quit their sharp turning, the street went back into good condition, and it has not raveled at all at that place since. You will find that those streets do ravel a little until they are open to traffic. Our streets, on a very hot day, will show the wheel marks. On a cold day, they will not. But we find that the ravelings work out under traffic. We haven't had any trouble with ravelings, except in some spots it seems as if they get perhaps a little too much screenings, and there is a little pocket of dust, and that dust is swept off and the foundation is good.

MR. R. M. WALLACE, of Alhambra. I would like to ask what the engineers would think about laying a pavement upon a street that has been thoroughly oiled under the petrolithic system. In Alhambra we have a street upon which we probably applied too much oil when it was first improved, for we found it too soft. We added a great deal of stone and finally made it a fairly good street. Now the citizens have taken it into their heads that they want to pave that street, and the question is whether they will lay this pavement on top of that petrolithic road that we have built, or first take the petrolithic pavement off. We have about decided that we will make a test of laying a surface on top of the old pavement. We may have to grade it down, as we want to raise the center of the street and railroad tracks higher. Some of us have grave doubts as to the policy

of laying this pavement on the petrolithic base. I will be glad to hear from some of the engineers as to that point.

MR. NOYES of Vallejo. We have had just such an experience in Vallejo, as I have stated here today. We have covered over about eighteen blocks of petrolithic work with bituminous concrete three inches thick and part of it with bitumen  $1\frac{1}{2}$  inches thick, placing the bitumen on the level streets and the bituminous concrete on streets carrying a grade up to 10 per cent. The treatment given the street was simply a thorough cleansing with the street sweepers and the taking off of the ridges by hand, and getting the street to as good a condition as possible before applying the cover. The bitumen was laid on the level road, and the bitumen cement on the grades, and the work has been in some three months or so now, and is very satisfactory in every way. It cost us  $7\frac{1}{2}$  cents a square foot for a  $1\frac{1}{2}$  inch covering of bitumen and  $9\frac{1}{2}$  cents for the 3 inch covering of bituminous concrete. I think we are going to have a very satisfactory lot of streets there.

MR. CABELL. I would like to say that, in the case the gentleman just mentioned, if that were in Riverside, we would try not to put in that old stuff at all, but would dig it up and store it for use for patching. We have a number of streets that are put in with a mixture of oil and earth, partially oil and partially gravel, and we have been using all that material for what we call patching, or in building alleyways, and things of that kind. We find that it is more valuable than to leave it in place.

MR. NOYES of Vallejo. Around the edge of the curb, we have concrete gutters, and in order to bring the covering down to the edge of the gutters, we had to pick out by hand about 3 inches against the edge of the gutter, and that material, as Mr. Campbell has said, is stored for the purpose of patching the streets, and we find it very excellent material. It has been very thoroughly mixed and tamped with the oil, and is thrown into the Corporation Yard, and whenever a little hole occurs that we want to fix up, we dump a little of that into it, and it makes a very excellent patch.

MR. VAN ORNUM. I think we have had a very interesting and valuable discussion here this morning. We will have to now go on with the order of the programme. We will next hear from Mr. Emory E. Smith of San Francisco, who will tell us something of San Diego's water system.

## BEFORE THE GENERAL BODY

THURSDAY, NOVEMBER 17, 1910, 1:30 P. M.

The convention was called to order by President Evans.

THE PRESIDENT. We will first this afternoon listen to a paper entitled "The Benefits Resulting from Municipal lighting in Pasadena", by C. W. Koiner, General Manager of the Municipal Lighting Plant at Pasadena. I take pleasure in introducing to you Mr. Koiner. (Applause)

### THE BENEFITS RESULTING FROM MUNICIPAL LIGHTING IN PASADENA

Pasadena, like many other municipalities, was forced to install a lighting plant in order that the streets might be properly lighted and further, in order that its citizens might have electrical energy at a reasonable price.

Bonds were voted to the amount of \$125,000.00 and a direct tax of \$52,332.35 was levied. With this sum the plant was begun and completed to the extent that the funds would allow. It was found that this sum was not sufficient to install a complete street lighting system so an additional bond issue of \$50,000.00 was authorized by the people and later, another issue of \$150,000.00 was authorized for the purpose of furnishing electrical energy for commercial light and power,—the last bonds having been voted seven to one in favor of extending the Municipal Lighting System.

At the time of the last bond issue, it was intended to supply electrical energy to about 2250 consumers. It was not the purpose of the city run the company with which it was entering into competition, out of the field. The city's desire was to establish a reasonable rate, to properly light the streets and to furnish all commercial users with electrical energy who desired to take of the city. At that time, the Southern California Edison Company offered to purchase the city's lighting system and give a maximum base rate of 9 cents per K. W. H. for commercial light and reduce the street lighting ten per cent. After careful analysis, this offer did not prove attractive and the Council courteously declined same and the officers of the Southern California Edison Company were waited upon with a view of the city purchasing their overhead system and with a further view of purchasing power at wholesale rates from them, provided it could be purchased at a rate lower than it would cost the city to generate it. The Company declined the proposition and the city continued to construct and complete its system over the entire city.

The city took over its street lighting July 1, 1907 and began to furnish commercial service October 1, 1908. It was estimated that the city could charge the following rates for street lighting, which was 60% less than it had been paying for incandescence lamps and 20% less for street arcs:

Arcs.....	\$5.00	per month
40 c. p. Tungstens.....	1.00	" "
60 c. p. ".....	1.50	" "
80 c. p. ".....	2.00	" "
Clusters Posts.....	.03	K. W. H.

The following scale of rates was established for commercial light and power, which was 33% less than the maximum base rate which consumers had been paying:

LIGHT		POWER	
First 100 K. W. H.....	\$ .08 per K. W. H.	First 100 K. W. H.....	\$ .04 K. W. H.
Next 900 ".....	.07 " "	Next 900 ".....	.03½ "
Next 4000 ".....	.06 " "	Next 4000 ".....	.03 "
Over 5000 ".....	.05 " "	Over 5000 ".....	.02½ "
Minimum rate \$ .80		Minimum rate \$1.00 per H. P.	

Prior to the agitation for a municipal plant, the opposition's base rate was 15 cents per K. W. H. and just before the installation of the municipal plant, they dropped the price to 12½ cents. From this rate, there was no discount given until a consumer had used 666 K. W. H. in one month.

The distributing system was extended to all parts of the city, even in sections where the citizens had never had service and could not get it unless they built their own lines or paid a bonus to the private company which was supposed to serve the community.

As referred to above, it was not the intention of the city to try to exterminate its competitor, however, as soon as the city began to take commercial service along



its lines, the opposition company started to make it unprofitable for the city. Flat rates were offered and ridiculously low rates were made for the express purpose of preventing the city from obtaining the amount of business it started out to secure. In order to prevent discrimination, the city passed an ordinance that all current sold must be sold at meter rates and the rates published and filed with the City Clerk, thus putting all users on an equal basis. The Southern California Edison Company then established the following rates:

LIGHT

First 100 K. W. H.....	\$ .05 per K. W. H.
Next 400 ".....	.04 $\frac{3}{4}$ per "
Next 500 ".....	.04 $\frac{1}{2}$ " "
Next 1000 ".....	.03 $\frac{3}{4}$ " "
Over 2000 ".....	.02 $\frac{3}{4}$ " "

The city found that it could establish a maximum base rate of 7 cents which it did, and continued to furnish light and power at these rates until the end of the fiscal year, June 30, 1910.

Near the close of the fiscal year ending June 30, 1910, the city plant showed up so favorably in earnings that it was decided to reduce the maximum base rate to 5 cents and thus put all consumers on an equal basis. The following schedule of rates was therefore established and went into effect September 1, 1910; these rates being 58% per cent below that charged at the inauguration of the Municipal Lighting System:

LIGHT

First 100 K. W. H.....	\$ .05 per K. W. H.
Next 400 ".....	.04 $\frac{1}{2}$ " "
Next 500 ".....	.04 " "
Next 1000 ".....	.03 $\frac{1}{2}$ " "
Over 2000 ".....	.03 " "

Minimum charge \$ .75

POWER

First 100 K. W. H.....	\$ .04 K. W. H.
Next 400 ".....	.024 " "
Next 1000 ".....	.02 " "
Next 3500 ".....	.019 " "
Over 5000 ".....	.0175 " "

(when used between 5 P. M. and 10 P. M.)

Over 5000 K. W. H.....	.015 K. W. H.
(Not used between 5 P. M.)	
Over 10,000 K. W. H.....	.015 " "

Minimum charge \$1.00 per kilowatt capacity of meter

The Southern California Edison Company established a base rate of 4 cents per K. W. H. at this time.

It was estimated that with 4000 consumers out of a possible of 6200, the city could earn sufficient to retire all outstanding bonds as they became due and pay interest on same and have left 3% for depreciation (the proper allowance for depreciation being 5%). With all things considered, a campaign was inaugurated for new business. A Municipal Light League was organized for the specific purpose of fostering the Municipal Light Plant and securing additional consumers. Many volunteer solicitors among the citizens went out and secured business from their neighbors with very satisfactory results; the city having at this time 3600 consumers with a prospect of obtaining the full 4000 users within the next three or four months.

I submit herewith the figures covering our last annual report which is compared with the previous year. After careful analysis of this report and in addition to the showing made, credit for the large sum saved to the citizens of Pasadena by reason of the reduction in rates, must be taken into consideration. The sum that this saving represents is between \$90,000.00 and \$100,000.00 per annum. This is based on a very conservative estimate and is increasing at the rate of 15 to 20%

per annum. This estimate is based on the actual amount of business done by the opposition company during the year of 1907, which, according to their sworn statement to the City of Los Angeles, was \$186,996.58. Of the above sum, only six months' bills for street lighting were included and in the above sum was included a small amount of earnings from Altadena and Lamanda Park, which did not amount to a very large sum. The gross receipts at this time at the old rates would not be less than \$240,000.00 per annum. Therefore the largest benefit resulting from the Municipal Lighting Plant of Pasadena is represented in this large saving effected by reason of the difference in the rates charged before the city established its plant and the rates established since. It will be noted that this saving would wipe out the entire cost of the Municipal Plant as it stands today, within the brief period of 5 years.

The average investment during the year for this department was approximately, \$350,000.00. Therefore, after the bonds had been retired and interest paid on all outstanding bonds, there remained an ample balance for taking care of depreciation.

In referring to the operating cost as submitted above, I wish to state that no effort was made to save the cost of operation at the expense of construction. During the past year, all of the General Manager's salary, all office expense, all expense pertaining to the up-keep of automobiles and motorcycles and half of the General Foreman's time were charged to operation, however, all of the engineering pertaining to the construction was done by the department and charged in as a regular operating charge. The facts as they occur in connection with the operation are given from month to month in order that the people may keep in touch with the actual cost of the operation and construction.

The report shows that the plant, operating at the maximum base rate of 7 cents or at the same scale of rates established for the fiscal year ending June 30, 1910, is abundantly able to earn all proper charges and set aside a sinking fund to take care of depreciation, providing that half of the business of the community is served from the Municipal Plant.

#### REPORT (in part) YEAR ENDING JUNE 30, 1910

##### RECEIPTS

Street lighting.....	\$33,311.24	
City buildings.....	1,129.80	
Commercial Light and Power.....	40,494.28	
Total receipts.....		\$74,935.32

##### EXPENDITURES AND OUTPUT

Manufacturing .....	\$22,719.28
Distribution.....	8,416.55
Micellaneous, Salaries, etc.....	7,493.58
Total Expenditures.....	\$38,629.41

INTEREST AND PRINCIPAL ON BONDS - - \$20,943.75

Total expenditures and output.....	\$59,573.16
Balance for depreciation or construction.....	\$15,362.16
Operating expenses 51.5 per cent of gross income.	
Efficiency of distributing system 79.7%.	

Capacity of station 1500 K. W., normal rating, consisting of direct connecting units, three in number.

Transformer capacity of the distributing system, 1900 K. W.

Pole line consists of 4275 poles in all parts of city.

Street lights consists of the following: 296 arc lights; 966 40 candle power Tungsten lights; 17 60 candle power Tungsten lights; 25 80 candle power Tungsten lights; 16 200 candle power Tungsten lights; 53 32 candle power carbon lamps; 130 cluster posts, 13 lights each.

Total number of meters set July 1, 1910, 2,357.

Orders on hand for meters to be set September, 1st. 599

Orders on hand for meters to be set after September 1st 800

Total meters to be set 1,399

BY C. W. KOINER.

THE PRESIDENT. This is a subject of considerable interest to us all. Are there any other cities represented that have municipal lighting plants who can add to our enlightenment upon the subject? Mr. White, of Palo Alto, have you not some information to give us?

MR. WHITE. We have a municipal lighting plant, but we have not had any competition such as the gentleman from Pasadena has referred to, so we do not charge less than 10 cents, but we show a good big profit from the operation of the plant.

THE PRESIDENT. I am sure Mr. Koiner would be very glad to answer any questions that may be asked.

MAYOR McNAB, of San Bernardino. Is your plant entirely a generating plant, or have you a contract to buy juice? I notice that you give the amount of cost per kilowatt hour at 1.24. Is that for generating power? Do you buy it at that, or do I understand that you generate the power yourself?

MR. KOINER. We generate all of our power with a steam plant, using oil for fuel.

MR. PRESIDENT. How many consumers have you?

MR. KOINER. Our average number of consumers for this entire year, was 1759. We have 3600 at the present.

MR. WARREN. I notice that the cost of manufacture increased about 20 per cent when you doubled your capacity. Can you tell us why?

MR. KOINER. Do you refer to the cost per kilowatt hour?

MR. WARREN. You stated 1.24 for the first year, and 1.58 for the second year, I believe.

MR. KOINER. I stated 1.24 for the second year and 1.13 for the first year. Part of the first year we only ran at night, and we had no long operating period with a very light load. I will say, for your information, that our load factor last year was only 19 per cent, and a load factor of 19 per cent is expensive—it runs your cost up per kilowatt hour for the day. While the net results for the whole year are much better, the cost per kilowatt hour on the whole was higher, because of our load. If we had the power to bring up the load during the hours of daylight and darkness, we would have had a much lower cost per kilowatt hour last year. You will note that the cost per kilowatt hour for September, which is a rather light month, too, was 1.589 for a total, as against 1.93 for the previous year. It varies from month to month. And the cost per kilowatt hour on the board was 1.02 and the previous year 1.19. There might be some repair work that would throw your cost very high for one month. Taken as a whole, it was a very favorable showing for that second year, considering our low load factor.



THE PRESIDENT. I think it has been proved beyond the shadow of a doubt that a city can own and operate a lighting plant and make a success of it, both financially and in service to the people. Mr. Mason suggests that I tell you about our Riverside plant. I will not enter into any extensive remarks concerning it. If any of you are vitally interested in this matter of municipal electric lighting plants, and will speak to me aside from the meeting, I will show you the reports and give you different figures regarding the situation.

MR. PAUL BANCROFT, of San Francisco. I would like to ask how the charges of the private corporation compare with those of the municipal plant in Pasadena.

MR. KOINER. You mean the cost of generation?

MR. BANCROFT. No, the cost to the consumer.

MR. KOINER. Our charge is 58 per cent less than the charge was at the time we started there.

MR. BANCROFT. Did you say there was a private company there, too?

MR. KOINER. Yes.

MR. BANCROFT. Do they charge more or less?

MR. KOINER. At the present time they are charging 20 per cent less than our rate.

THE PRESIDENT. I don't believe I am a municipal ownership crank, but municipal ownership as I see it and understand it, to be a success, has to be a municipal monopoly. If I were going to run a municipal electric light plant, I would have the whole business, and I would have no other company competing; and they won't in Pasadena, some day. That is not an unfair statement at all to the corporation that is also operating there, because, on the plea of the greatest good to the greatest number, municipal ownership of any public utility, to be a success, should mean that the people, being entitled to the greatest good, should have a monopoly of the lighting, if they can do it at anything like a reasonable cost. There are many things in the Riverside plant, as doubtless there are in the Pasadena plant and others, that make municipal ownership desirable. Outside the dollars and cents is the satisfaction of owning your own plant, and being enabled to apply your own methods and time of lighting your streets; all of which is far and above the little differentiation there may be in 5 cents or 6 cents. Our present maximum rate in Riverside for lighting is 9 cents. But, as I said a few moments ago, I won't go into any extended remarks on the subject. We have a monthly report given to our Board of Public Utilities showing in detail just what each department of the plant has cost. We have to buy most of our electricity from the Edison Company, and then we do the distributing. We have a steam plant that we run to take us over the peak of the load and reduce our maximum cost, but we have not run that very much; although we have a very fine steam plant, and our service is quite satisfactory and our charges reasonable.

We will next listen to an address by Mr. Percy V. Long, City Attorney of San Francisco, on the subject of the relation of water companies to cities. I introduce to you Mr. Long. (Applause)

Under the head of Miscellaneous Business, suggestions being called for;

MR. LOCKE. The city of Yreka, on the official letter-head used by its various officials prints this line: "Member of the League of California Municipalities". It seems to me that it would be a good thing for all the cities and towns of the league to do likewise; it would raise our organization in the estimation of outsiders. I hope this idea will be generally adopted.

THE PRESIDENT. That seems to be a very good suggestion. Any other suggestions?

MR. McNAB; We have had some contention in our city with reference to whether we should accept by ordinance street work done under the Vrooman Act, where improvements in pavement, curbing, water and gas pipes, have been constructed. I would like to ask what has been the policy of the various cities of the State in that regard?

THE PRESIDENT. Our city has refused to accept streets by ordinance.

MR. TOMALTY. Stockton accepts streets that have been done under the Vrooman Act, and absolutely accepts streets that have been sewered, and gas and water pipes therein, the work all being done to the full satisfaction of the city; and conditionally accepts streets on which some of this work is not done.

MR. WRIGHT. Santa Cruz accepts the streets under the Vrooman Act by ordinance. In some instances they accept the street and do not accept the sidewalks and curbs.

MR. PENDERGAST. The city of Redlands has adopted the same policy mentioned by the chairman, as, by not accepting, we can make the property owner pay for repairs. Otherwise the drain upon the general fund would be extreme for repairs.

THE PRESIDENT. Otherwise what are you going to be up against when you have all your street improvements done, and the streets wear out?

MR. McNAB. I noticed that the city of Los Angeles has considered this proposition, and according to the newspaper reports, I observe that they contemplate letting the Supreme Court determine whether that section is valid. A question was raised as to whether that section is not subordinate to Section 3 of the Act, and I would like to inquire if there is any city here represented which has had the problem presented of having a lot of streets accepted by ordinance and afterwards up for repaving. What has been done in that case?

MR. BUTCHER. My recollection is that that section of the Vrooman Act has been construed by the Supreme Court, and while they did not lay it down broadly that it is mandatory, the intimation is that it is, though what is said in that respect is simply dictum. But I am satisfied that if it ever comes squarely before the court, they will hold it to be mandatory, and for this reason: After the people have been put to the expense of preparing the street for the public, if they have done everything that can be done to put the street in a proper condition, it is nothing more than right that it should be kept in condition and repair thereafter by the public, who has the use of it. Otherwise, for instance, every time a council wanted to try some new experiment in front of your house in the way of paving, they could try it at your expense, and if that was not satisfactory, then try something else, making you pay for the work ad infinitum. The law is a just and wise one and I am satisfied will be upheld by the Supreme Court.

MR. McNAB. In answer to part of Mr. Butcher's statement, the law as it now stands provides that the city council cannot re-improve a street if fifty per cent of the property holders protest against it. When you accept the street by ordinance, you take away from the majority of the people on the street the power to improve their street in the future. I don't know what the experience of other cities has been, but the experience in our section is that it is proper to repave our streets when they wear out through taxing the property owners. If we do not, with a pavement that may go as high as three or four thousand dollars a block, if you have twenty miles of paved streets beginning to wear out, and perhaps wearing out about the same time, you are in difficulty. Another thing, if the street is

accepted, even if all the owners along a given block want to improve, except one, that one can block the efforts of all the others, and refer the matter to the City, which cannot, perhaps, afford it. We must not forget that a city is in a sense a myth—the people are the city, and it is not fair to go and levy a bond issue, and, moreover, you can't do it, because the people won't vote bonds for the repaving of streets down in front of my house, when they live out a mile or so.

MR. FREDERICK BAKER, of Glendale. I had occasion to investigate this question when our city was considering whether they would carry out a somewhat extensive system of street improvements under the Vrooman Act, ours being a city of the sixth class. After an investigation of the matter, I found, in the first place, that that provision had been carried forward from the old Street Improvement Law in force before the Vrooman Act was adopted, in the City and County of San Francisco. The purpose of it was to protect the property owners in San Francisco, where the expense of improving the streets, especially of grading, was very heavy, from repeated assessments. It seems that under the general scheme of Vrooman Act improvements, it is the intention of the legislature to put that expense really upon the abutting property owners, or the owners of the assessed district. I advised the city against making the formal acceptance of streets, thus leaving the streets subject to the power of the trustees to order them re-improved after the previous improvement had worn out, if it needed to be replaced. But I would suggest in that connection that, in order to meet the other contention, in some cases that is inequitable or too heavy a burden to be borne by the property owners, and that the plan resorted to by the city of Redlands and also by some other towns is an equitable division of the burden; that is, a general bond issue was made for the purpose of street improvements, and it was apportioned in this way; the abutting property owners, where they chose to come in under the plan, paid half of the expenses, and the trustees from the bond issue would pay the other half, the work being done under the Vrooman Act. That is authorized by the Act as being an equitable apportionment of the expenses.

MR. M. WALSH, of Petaluma. We have had that subject up for consideration in Petaluma. Our city accepted by ordinance. We have miles of streets needing re-improvement, but we have very little difficulty in getting our property owners to be willing to have the streets done. We have a rock crusher and a street roller, and it does not cost the city much to keep our streets in repair. Whenever any portion of a street does need repair, the Street Commissioner takes charge of it. We have streets down there for ten or fifteen years, and they are in very good condition. In my judgment, you cannot adopt a better system than accepting by ordinance. There will always be a great many people in a city who are not well off financially, and after they have paid a large amount of money for curbing and macadamizing, if you do not promise them that it will not cost them any more, the chances are that they will buck against the work in the first place. I think it is the best system for the small towns.

MAYOR FIREY of Pomona. Pomona has to deal with the very proposition of repavement of our standard asphalt streets. The surface is entirely worn out, having been down about fifteen or eighteen years, which is the average life of that class of surfacing on an asphalt or a concrete pavement. Our people finally petitioned the council to order the street repaved and resurfaced under the Vrooman Act. The previous council had refused to accept the street by ordinance. The petition was duly presented to the board, and we ordered the work done under the Vrooman Act and took the necessary steps. But they got up a counter-petition and came in with a protest. The work was hung up. The abutting prop-



erty owners met us with this argument, that they had been to a heavy expense to pave the street and that it was worn out by the general public. We are a fifth class city, and we levy a street tax every year of thirty cents. The property owners say to us that it is nothing more than equitable and just that they should either have been exempt from that street tax every dollar of which is spent on the streets, or they should be exempt from any requirement to pay it again under the Vrooman Act. I think there is some justice in that complaint. If our legal lights in this convention, who are laden with legal lore, could invent some kind of law by which we could set aside that levy for the purpose of reserving that street, we could meet that objection, and then I think there would be no difficulty. I was just wondering if that could be done.

MR. BUTCHER. I desire to suggest for the gentleman's edification and information, that the peculiar department known as lawyers laden with legal lore have taken the initiative in this matter, and a committee has been appointed. The matter will all be attended to in due time, and we will endeavor to get the act in such shape as to meet all these objections before the meeting of the next session of the legislature.

MR. ALFRED DAVIS, of Santa Barbara. There is only one street in Santa Barbara that has been accepted by ordinance.

MR. CRAIG, of Piedmont. I wish the legal department could arrange to raise the tax levy in cities of our class from 75 cents, to which we are now limited for general municipal purposes. We want to get a chance to tax out of their boots these fellows who hold their property unimproved for an increase in value, at the expense of those of us who improve our property.

MR. KIRKBRIDE. The attorneys have already answered that. It is now in the law.

MR LOCKE. It was changed through the efforts of this League at the last session of the legislature, and it is now one dollar.

MR. CRAIG. I want to say a word on the subject of street improvement. We took over a town that had been cut up into lots by speculative corporations, and they had made the road out of red rock, stuff that we have up in the hills. Occasionally there came along a streak of hard stuff in this mountain of dried red paint, and it was put down indiscriminately on the road. The soft stuff would wear out faster than the other, and we found bumps of the harder material sticking up. So last year we went to Santa Cruz with the idea of getting some information as to what to do with our red paint roads to get them in proper shape, because we thought the foundation was probably pretty good. We got no satisfactory information. So we had to work out our own salvation with road oil and screenings. For your information, I have here the figures of a little piece of road on which there is a great deal of travel. It is 1975 feet long and 31 feet wide. We put on three treatments of Associated road oil, three treatments of screenings (the first of road screenings, the next of rock) and we have now got that in pretty good shape at a cost of 8 cents per yard. Those are the exact figures, for the labor, screenings, oil, heating it up to the proper point, and the heater. Perhaps this will be of some value to some of the engineers who desire pointers as to the proper thing to put on a road. We green fellows took hold of it, and that is the result.

MAYOR DRULLARD, of Santa Cruz. Mr. President, in Santa Cruz we have had considerable difficulty in the matter of unaccepted streets. We would like some general information as to the care that they receive, and what you think are necessary improvements in the way of treating and preparing for the usual necessary grading.

MR. HYDE, of Palo Alto. In Palo Alto, just before the roads dry out, we send the road-scraper over them, closing the road up for a little. Later in the summer as the engineering department has time, they send the men out to clean the rubbish off from them. Of course, they cannot take as good care of the unaccepted roads as they do of the accepted streets, but that is the way it is done.

MAYOR DRULLARD of Santa Cruz. That is the problem. We have the means of doing this work, but how shall the bills be paid? How shall the work be paid for? The street fund is limited, and it is limited practically to the care and repair of accepted streets.

MR. HYDE of Palo Alto. We make up our budget including that very point—so much for watering the streets, so much for scraping and caring for the unpaved streets.

THE PRESIDENT. In Riverside this year we put an item in the budget for that work. We pick out the street, and then we go to the people on that street and we say, "It will cost about so much to run the grader over the street and fill up the chuck-holes and cut the weeds down. If you will put in half, (lately we say two-thirds) the city will put in the other third. If you will put in five inches of rock, then you will never have to do this kind of work again." We get the streets improved that way, that lead past avenues of travel and where the most traffic comes. So we get just double the use, now three times the use of our city's money.

MR. E. THELEN, of National City. In a case where the majority of property owners along a given street petition the trustees to widen the sidewalk, of course the trustees have to comply with the demand of the petitioners. In National City, we have some beautiful street trees and they are on the curblin in some instances. A large majority of the property owners have petitioned the trustees to widen the sidewalks to twenty feet, thereby saving all the streets. Three of the trustees refused to consent to it. I would like to know whether the board of trustees have to make the improvement when a majority of the property owners demand it.

MR. BUTCHER. I suggest to the gentleman that they work the recall in his city.

MR. THELEN. We do not have the recall.

THE PRESIDENT. I will see that the gentleman gets an answer from somebody to his question. We will have to pass along to the next order of business. A representative from Pasadena has a matter that he would like to call to our attention.

MR. KELLOGG of Pasadena. The subject is the marking of public comfort stations. It is perhaps a somewhat new matter, but one that, if once looked into and a plan adopted, the use and good of it will be seen. These stations are especially needful in towns where we have no saloons, as is the case with us. I have an article here written by our building and plumbing inspector in reference to that matter, which, however, I will not read. It shows the utility of it.

The public comfort station is very much in favor wherever it is used, we find. The particular question suggested by our engineer is the emblem, which he suggests might be a good one to adopt as a universal emblem for public comfort stations, and a red cross on a field of white within a circle of blue, with the letters in the center "M" for the men, and "W" for the women, I will say that the public comfort station has been generally adopted in the east, in very many enterprising cities, and is there considered of great importance.

(Then follows the report of committees, etc., etc.)

*(To be continued.)*

## REVISION OF THE VROOMAN ACT

---

At the recent San Diego meeting, the department of city attorneys appointed a committee on revising and simplifying the so-called Vrooman Act; also to examine and pass upon other legislation which might be proposed, affecting municipalities. Hon. William P. Butcher, president of said department, appointed the following attorneys on that committee: H. R. Osburn of Santa Cruz, W. J. Carr of Pasadena, S. G. Long and Frederick Baker of Long Beach, C. N. Kirkbride of San Mateo, Percy V. Long of San Francisco, L. D. Windrem of Richmond, and W. J. Locke of San Leandro. The committee met and organized Thursday evening, November 17, 1910, in the U. S. Grant Hotel, San Diego, electing H. R. Osburn chairman and W. J. Locke secretary.

It was decided to use the suggestions offered by Mr. Osburn as a basis upon which to work. Typewritten copies of these suggestions were given to each member with instructions to carefully consider the same and concur or dissent therewith, and in case of dissenting, to give the reasons for so doing.

The plan was carried out substantially as agreed upon, and the comments of each member, together with additional new suggestions, were mailed to the secretary. They were then compiled and again sent out for revision. Finally, a meeting of the committee was called for Wednesday, December 21st, 1910, at the league headquarters, in the Pacific Building, San Francisco, which meeting was attended by Messrs Osburn, Carr, Kirkbride, Windrem, and Locke; Mr. Percy V. Long was represented by Assistant City Attorney O'Brien. Mr. Mason, secretary of the league, was also present. Several communications were read, and a report was presented by Mr. Carr of Pasadena regarding meetings that had been held by the members of the committee residing south of the Tehachapi. It developed that there was almost a unanimous opposition to the substitution of a new act, or to any radical changes in the present act; not because the latter is such a good act, but because its various provisions have been so thoroughly adjudicated.

With this knowledge in mind, the committee proceeded to take up the various proposed changes seriatim, and after satisfactory discussion, adopted or rejected them by vote. The work of compiling the act, as proposed to be amended, was left to the secretary. The principal changes decided upon are as follows:

1. A division of the act into three parts, viz: Part I, relating to the doing of work under the general method of assessment by frontage or district; Part II, relating to change of grade; and Part III, relating to street improvement bonds, which may be issued when desired in lieu of cash payments;
2. A re-division of the different sections, according to the subject matter treated, each section embracing but one step in the proceedings, and all arranged in proper sequence;
3. Each section preceded by a suitable heading, indicating briefly but concisely, the particular matter contained in the section;
4. A provision is made that the street shall be designated in the resolution of intention by its legal or official name or the name under which it is commonly known. This will prevent another decision such as made by the Appellate Court, March 7, 1910, in the case of Peck vs. Benard, where the proceedings were declared invalid because the resolution did not give the true name of the street;
5. Section 2 is amended by adding to the work which may be done, among



other things, parking and park-ways, steps, tree planting, pipes for fire protection, conduits and subways for public utilities, septic tanks, etc.;

6. The word "also" is substituted for the word "thereupon", where it occurs in relation to the posting of notices by the street superintendent; this change will enable the street superintendent to commence posting his notices immediately upon the passage of the resolution of intention, without waiting until after the publication of the resolution has been completed, which often involves a loss of three weeks time;

The "publication" of the street superintendent's notice is dispensed with, as it is practically a repetition of the resolution of intention and absolutely unnecessary;

8. The notices to be "posted" by the street superintendent shall be headed "Notice of Improvement", a more comprehensive term, and be posted not less than 300 feet in distance apart, instead of 100 feet;

9. Written objections are required to contain post office address of each objector; also, in the matter of hearing objectors, provision is made for a continuance of the hearing if necessary;

10. In case a district is established, provision is made to permit the property-owners liable for assessment to object to the "work" as well as to the "extent" of the district;

11. The "publication" of the resolution ordering the work is dispensed with; instead, it shall be posted on the chamber door for 5 days;

12. A provision is added requiring that bids shall be "publicly opened" in open session of the council. It is said there are cases where clerks have secretly opened and read the bids, before they are read to the council, greatly to the benefit of a favored contractor;

13. A subdivision is added providing for payment of the cost of work done in front of public property (federal, state or municipal), or where such property is included in the assessed district. It provides that such property shall be proportionately assessed, and the amount of such assessment paid out of the general fund;

14. The section relating to the acceptance of streets is changed as follows: the clause "substantially paved in accordance with specifications adopted by ordinance" is added after the words "fully constructed" on the second line; acceptance is also made optional by the municipality, and it may be for all time or a term of years only. As some cities and towns pay a portion or the entire cost of street work from the proceeds of municipal bond issues, general taxation, etc., the question of accepting streets should be optional with each municipality;

15. In regard to the serial improvement bonds, it is proposed to make their issuance discretionary with the council, without requiring an estimate by the city engineer or restricting their issuance to work costing not less than fifty cents per front foot;

16. The improvement bonds are also made "conclusive evidence" of their validity instead of "prima facie" evidence;

17. The sidewalk act is repealed and the Vrooman Act restored for doing sidewalks;

18. The provisions in Section 9 enabling the contractor to secure a new assessment in case of defeats, errors or irregularities, have been made more definite and positive; for the purpose of further safeguarding the contractor. With the same object in view, Sec. 11, relating to final objections, has been made clearer and more certain, the idea being to remove as much as possible all chances of loss to the contractors by reason of any technical defects in the proceedings.

Anything that will reduce the hazard taken by contractors when they engage to do work under this act, is sure to reduce the cost of the work. One of the principal objections to the Vrooman Act has been the excessive charges imposed by contractors for doing work thereunder. As a matter of fact, after allowing for a fair profit, all contractors invariably add from 20% to 40% for the "hazard" they run in taking the contract at all; in other words, the property-owner pays for this hazard besides paying for the work. The amendments to sections 9 and 11, have been incorporated at the suggestion of a lawyer who is not only very familiar with the act, but who deals in the serial improvement bonds for himself and clients.

In conclusion, we may add that the committee has labored earnestly in an effort to accomplish some practical results that would be worth while.

The president and secretary of the committee, at the outset, obtained the views of many of the large street contractors and their attorneys in different parts of the state; therefore it may be truthfully said that the proposed amended act represents the composite idea of those who, by reason of their interest and experience, are best qualified to do the work. With the exception of one or two of the proposed changes, regarding which the members of the committee entertain some doubts, it is to be sincerely hoped that the legislature will pass the amended act as drawn. An effort will be made to have the committees of both houses of the legislature arrange a joint meeting for considering the measure, in which event the city attorneys and those who have so kindly assisted them will be requested to attend and support the measure with their oral arguments.



## QUESTIONS AND ANSWERS

---

Q.—In regard to the removal of a trustee of a city of the sixth class, for continuous absence from meetings, does not section 996 of the Political Code apply?

Ans.—Yes, the provisions of said section were successfully invoked in the case of *Loorbeer vs. Hutchison* 111 Cal. 272, also *Fleming vs. Shorb*, 100 Cal. 537.

Q.—Have telephone and telegraph companies the right to come into a city of the sixth class and erect poles, without the consent of the city trustees? M. R.

Ans. Telegraph companies doing an interstate business, yes, under the act of Congress of July 24, 1866, and telephone companies are claiming the same rights under this act; the matter is now in the Supreme Court of this state. See article in *PACIFIC MUNICIPALITIES* for March, 1910, by Mr. J. P. Wood, former city attorney of Pasadena.

Q.—Is it lawful for the trustees of a city of the sixth class to pay the expenses of one of its members to a convention of the League of California Municipalities?

Ans.—It is generally understood by city attorneys that the municipalities organized under the general laws, have that right. Under subdivision 19 of Section 862 of the Municipal Corporation Bill they may do whatever they believe to be for the best interests of the city, providing it is not unconstitutional or inconsistent with the express provisions of the general laws. Nearly all the municipalities participating in our annual meetings, pay the expenses of their delegates.

Q.—We beg to inquire if you happen to have any figures as to the number of small towns which are equipped with a fire alarm system of any magnitude. Would like to be enlightened as to cost of installation, maintenance, results, and most particularly we want to know the pro-

portionate number of fire calls coming through the system as compared with those which come over the telephone.

Ans.—Enclosed we sent you a partial list of the cities and towns of California having systems. There are four agencies in California. It costs between \$3,000 and \$4000 to install a fire alarm system in a city of 3500 inhabitants. We are reliably informed that the percentage of fire alarms coming in over the telephone is between 65% and 85%.

Q.—I am desirous of obtaining a copy of an ordinance fixing telephone rates; also one granting permission or giving to the city authority to look after, or to open and fill in all excavations made by gas and water companies, in putting in service mains from street to property lines. The city authorities wish to exercise this power, if you have these ordinances or can obtain them for me I will be duly grateful.

Ans.—Yours of yesterday at hand. Enclosed you will find copies of ordinances fixing telephone rates.

Alameda has just passed an ordinance providing that all necessary excavations in the streets shall be made by the Superintendent of Streets; that is, under his supervision. Suggest that you write City Attorney Simpson of Alameda for a copy.

Q.—Has a city or a town a right to regulate the rates to be charged for electric lights furnished to the residents and the city in general?

Ans.—Your inquiry of yesterday received. Replying thereto will say that you have that right under the provisions of Section 19 of Article XI of the Constitution.

Q.—The Board of Trustees has directed me as city attorney to prepare and call a special election for the following purposes:

- (1). To incur an indebtedness of \$10,000.00 for fire apparatus.
- (2). To incur an indebtedness of \$40,000.00 for purchase of site and erection of public building.
- (3). To obtain the consent of the voters of the city to the application of a surplus on hand in Bond Fund No. 6 for the purchase of a site and the construction of a municipal building.

It occurs to me from reading the municipal improvement act, that no other question than that of incurring an indebtedness can be submitted by a city at such special election, and that the submission of the special question as outlined in the third proposition above, would probably invalidate the election. I am unable to find any authority touching directly on this question, and if you can cite me to any I shall appreciate your courtesy. Your early attention and reply will be very much appreciated.

Ans. It would undoubtedly invalidate the proceedings of a bond election to submit any other question than that of incurring the indebtedness, according to the express provisions of the bond act. See Section 2 of Act 2371.

It is not necessary to obtain the consent of the voters to use any surplus remaining in another bond fund. Act 2346, (Statutes 1899, page 105) provides that such surplus may be turned into the general fund. Should the trustees desire the indorsement of the voters to a project to use such surplus for the purchase of a site and the construction of a public building, would suggest that a straw vote be taken, say for instance, by means of a return postal card.

Q.—Can you advise me if there is any law in this State, permitting a city of the fifth class to create a district out of one portion of the municipal territory for the purpose of bonding same to put in water works for that specific portion?

Ans.— There is no law on the statute books at the present time permitting the creation of water districts. You will find enclosed however, the copy of a bill now before the assembly on the matter of sewer districts, which might be easily amended according to the penciled interlineations so as to provide for water



districts as well as sewer districts. We suggest that you write to the assemblyman who has introduced this bill and ask him to amend it as suggested, giving your reasons therefor. It would be well also to write to your assemblyman and senator telling them about it, and asking them to look after it. Mr. Mason will be going up to Sacramento about the end of the week and he will interest himself in the matter also. There should be no difficulty in getting the bill amended as suggested, and this would cover the matter completely.

Q.—In a case where proceedings have been regularly carried out in regard to the improving of a certain street under the Vrooman Act years ago, but failed for want of bidders. Now, new proceedings under the district act to improve the same street, have been carried on to the point of advertising for bids, would it not be necessary to repeal all prior proceedings before advertising for bids?

Ans.—The proceedings taken years ago have been abandoned, particularly so, if you paid the cost of printing and other incidental expenses on the proceedings. Nevertheless it is advisable under all circumstances to revoke all former proceedings taken for the improvement of such street. However, after several years have elapsed, and abandonment practically confessed by payment of the incidental expenses, it is unnecessary, and inadvisable at this time to take any cognizance of any former proceedings.



## WILL TEST THE VALIDITY OF AMENDMENT

### Council Starts the Fight to Question the Legality of Measure

SAN BERNARDINO SUN, JAN. 17, 1911

By the action of the City Council last night the validity of Amendment No. 1, adopted at the last general election, will be tested in the Supreme Court, and also a bill will be introduced in the legislature to provide for the reimbursement of losses to cities by counties as the result of the amendment, as contemplated by the amendment itself.

Both are separate issues, but both vitally important to San Bernardino county and the cities of San Bernardino county. The determination to test the legality of the amendment is of State-wide importance. For the reason of its railroad assessment, which exceeds any other county in the State, the amendment concerns San Bernardino county perhaps more than any other.

The fact that the county must, if the legislature follows the provision of the amendment, reimburse the cities which suffer a loss was a surprise.

#### SWING SUSTAINED

City Attorney R. E. Swing, addressed an opinion to the Council on the subject.

The Council endorsed his recommendation and instructed him to at once prepare a bill for passage by the legislature, as provided by the amendment, requiring the counties to reimburse the cities for losses by means of the enactment of the amendment, and to also call a conference of the city attorneys of San Bernardino county to prepare a fight to test the validity of the amendment.

#### THAT JOKER

The opinion of the city attorney is the result of the discovery of a "joker" in the amendment. A provision which hitherto has remained very much in darkness,

provides that the legislature take steps to have the counties reimburse districts for losses. The steps taken by the Council were to call the attention of the legislature to the amendment provision, reading. "The legislature shall provide for reimbursement from the general funds of any county to district therein where loss is occasioned in such districts by the withdrawal from local taxation of property for State purposes only."

The county is reimbursed by the State for loss from railroad taxation for a period of eight years, but the interpretation on the newly discovered provision is that all loss, from railroad and other assessment, must be reimbursed to the city, and not only for a period of eight years, but indefinitely.

The city of San Bernardino has at stake from \$10,000 to \$12,000 annually.

#### AN IMPORTANT MOVE

The decision to test the validity of the amendment is important to both the county and cities, and undoubtedly the officials of the county will assist in the fight, as a huge sum is at stake in San Bernardino county particularly.

To get the matter into the courts Mr. Swing will arrest the manager of some corporation operating within the city which refuses to pay the quarterly license tax, from which public service corporations are also apparently exempt under the amendment, although Mr. Swing desires this point also determined. The validity of the amendment will then be argued.

The city attorney is not yet ready to announce the points by which he is preparing to question the legality of the amendment.

#### Safeguarding Records From Fire

One of the bills now before the legislature provides that duplicate copies shall be kept of public records, so that in case the originals are burnt or otherwise destroyed, the duplicates may be used.

The idea should be carried out in municipalities, especially when they have no fire-proof vault. It has been suggested for the small cities for instance, that the original copies of ordinances might be kept in the town hall, while the ordinance book could be kept by the clerk in some other place. By this plan, there would always be an authentic copy on hand, should one copy be destroyed. The same is true of the records of the surveyor or engineer; it would involve great expense and annoyance in case of their loss.



#### "HYGENIC" DRINKING FOUNTAIN

For Schools, Railway Stations, etc. Prevents contagion and provides each user with an ample supply of fresh water.

Illustrated circular sent on request.

The newest things in plumbing fixtures for Schools, Factories and Office Buildings are on display in our Show Rooms.

851-859 Folsom Street, San Francisco, Cal.

Phones, Sutter 1130; Home J-2110

**Haines, Jones & Cadbury Co.**

Makers of Plumbing Supplies

1130-1144 Ridge Avenue, Philadelphia

Branches—Savannah and San Francisco

## EDITORIAL

### The Proposed State Highways

The highways act recently adopted by the people of the state provides in section 8, that "the highway constructed or acquired under the provisions of this act shall be permanent in character and shall be finished with oil or macadam or a combination of both, or of such other material as the judgment of the said department of engineering shall be most suitable and best adapted to the particular locality traversed."

This act involves the expenditure of the vast sum of eighteen million dollars, and the people of the state do not want to see it wasted on experiments or expended on makeshift pavements which would be burdensome to keep up.

The considerations involved call for the appointment of a state engineer and assistants who are thoroughly competent and experienced, and familiar with the peculiar local conditions prevalent here in California.

The men who undoubtedly possess these requisite qualifications in the highest degree may be found among our city engineers, and it is therefore a source of considerable satisfaction to note that Van Ornum of Pasadena, Randle of Sacramento, and Jensen of Fresno, are among those mentioned for these responsible positions.

### Chicago's Municipal Congress

Another communication has been received at headquarters regarding our participation in the International Municipal Congress and Exposition to be held in Chicago, September 18-30, 1911. The letter says, in part:

"We had in mind that San Francisco,

Los Angeles and several other enterprising California Municipalities could make an interesting exhibit, either of some notable street improvement, municipal buildings, parks and parkways, civic centers or some similar undertaking. It is desired to get this department of the Exposition under way at as early a date as possible in order that ample time can be had by municipalities for preparing such exhibit."

It will be recalled that a resolution was unanimously adopted at the recent San Diego convention declaring that the League of California Municipalities would participate in this congress. It becomes necessary therefore to determine just how it should be done. Buildings, parks or civic centers constructed in miniature are expensive, and this form of exhibit could only be afforded by our largest cities. The most reasonable proposition has been suggested by our secretary, Mr. H. A. Mason. His idea is to issue a massive souvenir book after the style of our large-page magazines, containing photo-engravings of the public buildings, parks, civic centers, etc., of the cities and towns of California, with appropriate information regarding their municipal progress and achievements, these books to be issued to the number of fifty thousand or more and distributed at the exposition. City officials are requested to take this matter under consideration and advise this office of any ideas they may have on the subject.

### Trade Notes

A year ago the J. I. Case Threshing Machine Company offered a free trip to the factory to two salesmen in each territory. The trip was a reward to the salesman selling the most goods for the year, and the salesman showing the



largest increase over the year 1909 in the territory he worked for that year. No one salesman was allowed to have both records. As a result about seventy (70) salesmen are now in Racine looking over the plant and getting a line on our output for the coming year, also receiving instructions that will help them in their sales work.

While they are here they are the guests of the J. I. Case Threshing Machine Company, and will be entertained by them. The time they spend at the factory will be three days.

The Warren Brothers Company, one of the largest paving firms in the country, is about to enter the paving business in California. This will be good news, as it means keener competition and an assurance of fairer prices.

Gorham Engineering and Fire Apparatus Co., has succeeded to the Fire Department Apparatus & Supply business formerly conducted by the Gorham Rubber Co. The new concern has offices in Seattle and Los Angeles, as well as at 48 Fremont Street, San Francisco. Their show room will be filled with all manner of supplies and contrivances used by firemen. They are Pacific Coast agents for The Nott Fire Engine Co., The Seagrave Co., the Sieben System of Sanitation, Blymer Bells and other well known line of goods.

Fire Hose is one of their specialties, and an entirely new proposition, that should appeal to all users of this article, is being offered by them.

Their new offices and salesroom will be open for business by February 15th.

The Knox Combination Hose and Chemical is a very complete fire fighting unit.

Besides being capable of forty miles an hour, which is seldom used, it carries a thirty-five gallon chemical tank, which

can be quickly recharged at a fire, 200 feet of chemical hose, 1000 feet of hydrant hose, a searchlight, extension ladder, two hand extinguishers, a life line, axes, door openers, and everything that could possibly be called into play. Mounted upon the modern automobile fire fighter is a swivel "gun" built upon a stand. Through this very efficient nozzle the combined streams from several lines of hose can be thrown in any direction by one man. So powerful is this that a heavy stream can be projected an unbroken column fourteen stories high.

New York Fire Commissioner Waldo, the most efficient commissioner the city ever had, speaking of the Knox Motor Hose Cart said that it could cover much more ground in less time and carry twice as much hose as the horse-drawn vehicle while the expense is much less.

He states that the total cost of maintaining the Motor Hose Cart last year for repairs, gasoline and oil was only \$50, while the cost of feeding, stabling and shoeing a team of horses was about \$1,200—some difference. The auto involves expense only when in use while the horse equipment is a constant drain in feeding.

The automobile for fire fighting is not coming, it is here and will continue to spread as long as "Time is Money."

#### COMING

in PACIFIC MUNICIPALITIES for February, 1911, THE NEXT ISSUE.

"Reducing the Fire Hazard in Municipalities" by Geo. N. Robertson, Engineer of Board of Fire Underwriters of the Pacific.

"Oakland's High Pressure Fire Fighting System," by Assistant City Engineer Brown of Oakland.

"The Use of Automobiles and Chemicals in Fire Fighting," by Louis Almgren, Jr., Chief of the San Diego Fire Department with the discussion that followed in each case.

### What the Cities Are Doing

City officials are requested to keep us informed on these matters.

**Napa** will build a garbage crematory.

**Madera** is planning a lot of sidewalk work.

**Lodi** is planning extensive street improvements.

**San Mateo** is constructing a lot of cement sidewalks.

**Concord** will vote on a large bond issue for a sewer system.

**Chico** is about to construct 56 concrete street crossings.

**Santa Cruz** freeholders have submitted a proposed charter.

**Visalia** officials are talking of procuring a modern fire engine.

**Nevada City** firemen ask to be furnished with rubber coats.

**Los Banos** trustees are investigating the question of water rates.

**Dorris** has started proceedings on a bond issue for a water system.

**Ventura** is about to start the erection of a \$75,000 Union High School.

**Antioch** and **Oakland** will soon be connected by a new railroad.

**Mayfield** is considering the installation of some corrugated iron culverts.

**Lemoore** has commenced proceedings on a bond issue of \$19,700 for sewers.

**Berkeley** citizens are petitioning Mayor Hodghead to stand for re-election.

**Los Angeles** expects the \$10,000,000 subway project to be commenced any day.

**Piedmont** has received the new auto chemical recently purchased by the trustees.

**Alturas** is about to install a new water system. The work will be under the supervision of Sloan and Robson, the well known engineering firm in San Francisco.

**San Mateo** has secured a premium of \$1482.00 on its \$56,000 5 per cent bonds.

**Modesto** is considering the purchase of an auto combination chemical and hose wagon.

**Vallejo** received \$91,980 for its \$90,000 5 per cent water-works bonds, recently voted.

**Santa Monica** will vote on a bond issue for the construction of a polytechnic high school.

**Auburn** firemen and citizens are raising money for the purchase of a chemical engine.

**Jackson** is making big efforts to secure the location for the Amador County High School.

**Claremont** High School District received bids on February 2, for their new high school.

**Chico** trustees have passed an ordinance requiring all electric wires to be placed underground.

**Hanford** trustees are having arguments on the relative merits of vitrified and cement sewer pipe.

**Emeryville** is considering the purchase of two automobile fire engines to cost approximately \$12,000.

**San Jose** police and fire commissioners have decided to equip the fire department auto with chemical apparatus.

**Visalia** will shortly vote on the question of issuing \$40,000 bonds for the site, erection and furnishing of a pavilion.

**Antioch's** fire chief is advocating the purchase of an automobile hook and ladder truck like the one procured by Napa.

**Anaheim** citizens held a mass meeting on January 23, to discuss a new sewer system and extensions to their lighting plant.

**Redondo Beach** will receive bids on February 13, for furnishing a 50 horsepower chassis for mounting chemical fire wagon.

**Los Gatos** has received an estimate from Engineer Chandler to the effect that the proposed sewer outlet would cost \$25,000.

**Chico** citizens are advocating the construction of a \$45,000 or \$50,000 high school on the site of the old building which was burned on January 12.

W. J. LOCKE

H. A. MASON

## Mason & Locke

ATTORNEYS AND COUNSELORS AT LAW

*Bond proceedings conducted---validity and sale guaranteed*

Ninth Floor Pacific Building

SAN FRANCISCO

## LIST OF RESPONSIBLE FIRMS TO BE CALLED ON TO BID FOR PUBLIC WORK OR SUPPLIES

### WRITE FOR CATALOGS

This list is arranged as a guide for the accommodation of city officials where advertising for bids is not necessary.

#### Accountant

William Dolge, C. P. A., 255 California St., S. F.

#### Architects

W. H. Weeks, 251 Kearney St., S. F.

#### Asphalt Machinery

J. I. Case Thresh'g Mch Co. 616 Myrtle St. O'kl'nd  
A. L. Young M'chy Co. 26-28 Fremont St., S. F.

#### Arch. Terra Cotta

Gladding, McBean & Co., Crocker Bldg, S. F.  
Steiger Terra Cotta & Pottery Wks, 729 Mills  
Bldg., S. F.

#### Automobile Public Service Wagons

The Thomas B. Jeffery Co., 117-125 Valencia  
St., S. F.  
Reliance Auto. Co., 342 Van Ness Ave., S. F.

#### Bitulithic Pavement

Warren Brothers Company, Los Angeles, Cal.

#### Blue Prints

So. Cal. Blue Print & Supply Co., 800 L. A.  
Trust Bldg., Los Angeles.

#### Bridge Builders

E. T. Thurston, Jr., Wells Fargo Bldg., S. F.

#### Concrete Construction

Esterly Con. Co., Inc., 717 Market St., S. F.  
Hazelwood, Jones, Doane & Hanscom, 675  
Monadnock Building, S. F.

#### Contractors and Builders

Finch Jail Building and Metal Co., 16 Cali-  
fornia St., S. F.

#### Constructing Engineers

Fred'k C. Roberts & Co., 221 Sheldon Bldg, S. F.

#### Consulting Engineers

Sloan & Robson, Nevada Bank Bldg., S. F.  
E. T. Thurston, Jr., Wells Fargo Bldg., S. F.

#### Culverts

Cal. Corrugated Culvert Co., Los Angeles and  
W. Berkeley

#### Drinking Fountains

Haines, Jones & Calbury Co., 851-859  
Folsom St., S. F.

#### Dump Carts and Wagons

J. I. Case Thresh'g Mch Co. 616 Myrtle St. O'kl'nd  
A. L. Young M'chy Co., 26-28 Fremont St., S. F.

#### Electrical Plants & Machinery

A. L. Young M'chy Co., Fremont St., S. F.  
Chas. L. Kiewert Co., 195 Fremont St., S. F.

#### Engravers and Bond Printers

A. Carlisle & Co., 251 Bush St., S. F.  
Commercial Art Co., 53 Third St., S. F.  
Schmidt Lith. Co., Second & Bryant Sts., S. F.  
Sierra Art Eng. Co., Front & Com. Sts., S. F.

#### Fire Engines

Gorham Rubber Co., 50 56 Fremont St., S. F.

#### Fire Hose

Gorham Rubber Co., 50-56 Fremont St., S. F.  
New York Belting & Packing Co., 129-131  
First St., S. F.

#### Lithographers

Schmidt Lith. Co., Second & Bryant St., S. F.

#### Metal Furniture

Finch Jail Bldg. & Metal Co., 16 Cal. St., S. F.

#### Municipal Accountant

William Dolge, C. P. A., 255 California St., S. F.

#### Municipal Printers

A. Carlisle & Co., 251-253 Bush St., S. F.

#### Municipal Engineers

Fredk. C. Roberts & Co., 461 Market St., S. F.  
Sloan & Robson, Nevada Bank Bldg, S. F.

#### Pavement Materials

Warren Brothers Company, Los Angeles, Cal.

#### Playground Apparatus

A. L. Young Machinery Co., S. F.

#### Riggers

C. A. Blume Con. Co., 185 Stevenson St., S. F.

#### Road Machinery

J. I. Case Threshing Mch. Co., 616 Myrtle  
St., Oakland, Cal.

Henshaw, Bulkeley & Co., Fremont St., S. F.

A. L. Young M'chy Co., Fremont St., S. F.

Petrolithic Pav. Co., 209 E. 7th St. Los Angeles

#### Safes

Victor Safe & Lock Co., 1292-4 Market St. S. F.

#### Scrapers

J. I. Case Thresh'g Mch Co. 616 Myrtle St. O'kl'nd

A. L. Young M'chy Co., Fremont St., S. F.

Petrolithic Pav. Co., 209 E. 7th St. Los Angeles

#### Sewer (Concrete)

Esterly Con. Co., Inc., 717 Market St., S. F.

#### Sewer Pipe and Terra Cotta

Gladding, McBean & Co., Crocker B'ldg, S. F.  
Steiger Terra Cotta Co., Mills B'ldg., S. F.

#### Sidewalks (Cement)

Esterly Con. Co., Inc., 717 Market St., S. F.

#### Street Signs

A. L. Young Mch. Co., S. F.

#### Street Sweepers

A. L. Young M'chy Co., Fremont St., S. F.

#### Structural Steel Erectors

C. A. Blume Con. Co., 185 Stevenson St., S. F.

#### Vaults

Victor Safe & Lock Co., 1292-4 Market St., S. F.



# Henshaw, Bulkley & Co.

## ROAD MACHINERY

### A SPECIALTY

19-21 Fremont Street  
San Francisco

262-264 So. Los Angeles St.  
Los Angeles

# The Commercial Art Co.

INCORPORATED

## Designers & Engravers

53 Third Street

San Francisco

TERRA COTTA, PRESSED BRICK, PIPE,  
FIRE PROOFING, ROOFING TILE,  
FLUE LININGS, FIRE TILE,  
LAUNDRY TRAYS,  
ETC.

**GLADDING, McBEAN & CO.**

WORKS  
LINCOLN, CAL.  
--- OFFICE ---  
311-317 CROCKER BLDG., SAN FRANCISCO.

# Steiger Terra Cotta and Pottery Works

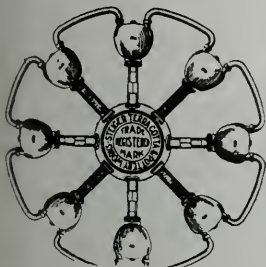

MAIN OFFICE AND YARDS:

City Yard, 18th and Division Streets

Main Office: 729 Mills Building

Phone Douglas 3010

SAN FRANCISCO, CAL.

Factory, South San Francisco  
San Mateo County



Fire Apparatus  
Police Patrols  
Ambulances

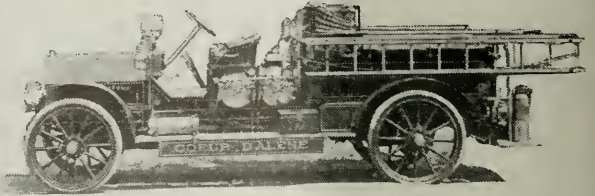

REPRESENTED BY

**RELIANCE AUTOMOBILE CO.**

342-352 Van Ness Ave.

SAN FRANCISCO

F. W. Haselwood, Assoc. M. Am. Soc. C. E.

Sidney Jones

E. W. Doane

W. A. Hanscom

**Haselwood, Jones, Doane & Hanscom**  
*Civil, Hydraulic and Sanitary Engineers*

*Sewers, Waterworks, Light Plants, Street Work and Bridges*

Phone Sutter 1337

675-677 Monadnock Building

SAN FRANCISCO, CAL.

**E. T. THURSTON, Jr.**

Assoc. M. Am. Soc. C. E.

**Consulting Engineer**

713 Mechanics' Institute

Phones Sutter 1683 and C 2895

SAN FRANCISCO

**Specialties**

Design and Supervision of Buildings, Bridges,  
Railways, Water Works and Municipal Work

**Concrete Bridges**

Exclusive rights under patents of National  
Bridge Company, the largest in the world.  
Estimates furnished free of charge.

**C. A. BLUME CONSTRUCTION CO.**

Members of Builders Exchange

**Structural Steel Erectors**  
**Riggers**

Phone Douglas 324  
185 STEVENSON STREET

SAN FRANCISCO

**ESTERLY CONSTRUCTION CO., Inc.**  
**CONCRETE CONTRACTORS**

Buildings, Bridges, Sidewalks, Walls, Floors, Foundations  
Room 605, 717 Market St., San Francisco

2136 Center St., Berkeley



**WILLIAM DOLGE**

*Certified Public Accountant --:-- Municipal Accountant*

TELEPHONE DOUGLAS 5173

255 California Street

San Francisco, Cal.

**WM. H. WEEKS, Architect**

PUBLIC BUILDINGS A SPECIALTY

251 Kearney Street

San Francisco

**SLOAN & ROBSON, Engineers**

Reports, Designs, Estimates and Supervision of Municipal  
Light, Water and Sewer Systems

Telephone Kearney 4646

Nevada Bank Building, SAN FRANCISCO

**GORHAM RUBBER CO.**

RUBBER GOODS OF EVERY DESCRIPTION

Fire Hose, Chemical Engines, Hose Carts, Packing

**50-56 Fremont St., San Francisco**

**THE CLARA BARTON**

**Sanitary Wiping Rags**

The Clara Barton Brand of Wiping Rags  
are Guaranteed to be thoroughly sterilized  
and disinfected. Telephone Market 2286

**The Raychester Co., Inc.**

1448-1460 FOLSOM ST., SAN FRANCISCO





The  
Bitulithic  
Pavement  
For Streets  
and Roads



1 Mile	7 Cities
22 Miles	33 "
52 "	40 "
59 "	45 "
59 "	42 "
85 "	57 "
109 "	66 "
95 "	62 "
118 "	74 "
679 "	216 "

**TOTAL MILES (30 Ft. Road)**

Combines the inherent stability of the mineral aggregate with the cementing qualities of the asphaltic oil, or other bituminous cement, and produces a smooth, dustless, waterproof pavement, suitable for automobile traffic and driving--prevents skidding and affords a good foothold for horses--is COVERED BY PATENTS, the VALIDITY of which has been SUSTAINED BY THE SUPREME COURT OF THE UNITED STATES.

Send for circulars showing where used and methods of construction.

**WARREN BROTHERS COMPANY**

Portland, Ore.

Boston, Mass.

Los Angeles, Cal.  
616 Laughlin Bldg.

REGISTERED TRADE MARKS

"Bitulithic" "Warrenite" "Puritan" "Bitrock" "Bituminous Macadam" "Bitustone"

**MAPS**  
**BONDS**  
**STATIONERY**  
**BOOKLETS**  
**POSTERS**  
**LABELS**  
**CARTONS**  
**ETC.**

**SCHMIDT LITHOGRAPH COMPANY**

MAIN OFFICE  
SAN FRANCISCO.

PORTLAND      LOS ANGELES

**FINCH JAIL BUILDING AND METAL CO.**

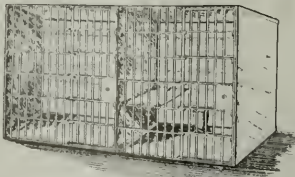

Manufacturers and Builders of

**PRISON CELLS AND ALL APPUR-  
TENANCES.**

Dealers in Metal Furniture and Fixtures

Office No. 16 California St.

Telephone Kearney 935

# GOLDEN STATE LIMITED

¶ The embodiment of the best in the railroad world of travel, insuring a trip of comfort, convenience and enjoyment.

¶ Daily between San Francisco, Los Angeles, St. Louis and Chicago via Los Angeles and El Paso.

## Southern Pacific

### TICKET OFFICES:

Flood Building

Palace Hotel

Market Street Ferry Depot

Third & Townsend Sts. Depot

Broadway & 13th St.,

Oakland

## **A. CARLISLE & CO.**

### **Stationers, Printers and Bookbinders**

We specialize in Bonds, Steel Die, Lithographed or Printed, for Municipalities or Counties, and the Books and Forms required by all Municipal Officers.

**251-253 Bush Street**

**San Francisco, Cal.**

# MUNICIPAL AND CONTRACTORS' MACHINERY

...FOR...

## GOOD ROADS AND STREETS

- Street Signs
- National Road Machines
- Fort Wayne Road Machines
- Indiana Road Machines
- National Elevating Graders
- Elevators—Portable Bunkers
- Shares or Cutting Edges for all types of Road Machines
- Rock Crushers, Jaw and Gyratory Type, mounted and unmounted
- Screens
- Steam Road Rollers
- Horse Rollers
- Scarifiers
- Harrows for oiled roads
- Wheeled and Drag Scrapers
- Fresno Scrapers
- Reversible Road Plows
- Street Sprinklers
- Sprinkling Attachments
- Street Sweepers
- Fibre for Street Sweepers
- Watson Dump Wagons
- Asphalt Machinery
- Kettles—Hand Rollers—Tampers
- Concrete Mixers
- Hoisting Engines
- Playground Apparatus
- Culvert Pipe

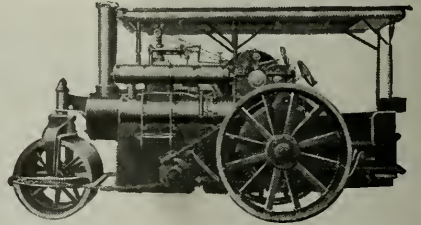
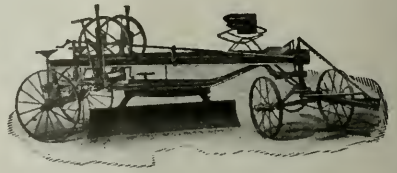

Write us for Catalogues and Estimates

## A. L. Young Machinery Co.

26-28 Fremont Street

San Francisco

California



# PACIFIC MUNICIPALITIES

THE CITY BEAUTIFUL



PUBLIC  
SAFETY  
HEALTH  
CONVENIENCE

PUBLIC  
UTILITIES  
EDUCATION  
RECREATION

PUBLISHED MONTHLY

SIERRA'S F



When a man feels the necessity of being in two places at the same time he goes to the nearest telephone and sends his voice. It is not exactly the same thing, but when a man talks hundreds of miles in opposite directions from the same Bell Telephone, it is about as good. In the daily use of the telephone a man travels all over town by wire in a few minutes. It is just as easy to travel all over the state and other states by means of the universal Long Distance Service of the Bell System.



**The Pacific Telephone & Tel. Co.**  
*Every Bell Telephone is the Center of the System*



SILENT

LUXURIOUS

3 MODELS

*THE NEW Rambler*

Touring Cars, Motor Fire Trucks, Chemical, Hose, Police Patrol and Ambulances a Specialty.

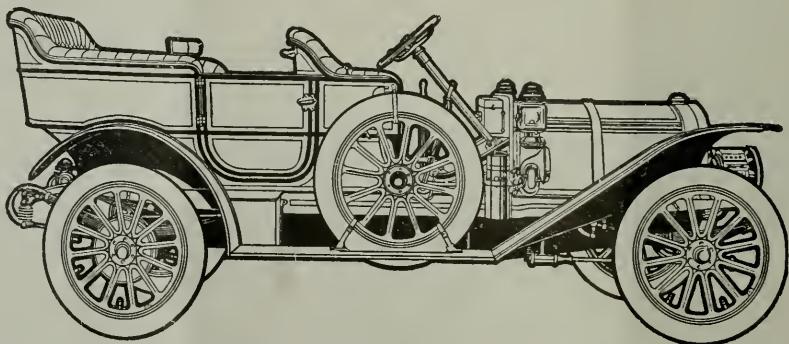

**The Thomas B. Jeffery Co.**

117-125 Valencia St.

WRITE FOR INFORMATION.

San Francisco

Please mention PACIFIC MUNICIPALITIES when writing to Advertisers

PACIFIC MUNICIPALITIES

# CASE LINE...

Municipal Hauling Engines  
Contractors' General Purpose Engines  
Steam Steered Road Rollers  
12 & 16 Bbl. Mounted Fuel and Water  
Engine Tenders for Engines and  
Road Rollers  
Troy Bottom Dump Wagons  
Road Graders  
Road Scrapers  
Road Rooters and Road Drags

Write for our general catalog "M." Address Road Machinery Department.

**J. I. CASE THRESHING MACHINE COMPANY, Inc.** RACINE, WIS.,  
U. S. A.

BRANCH OFFICE, 616 MYRTLE ST., OAKLAND, CAL.

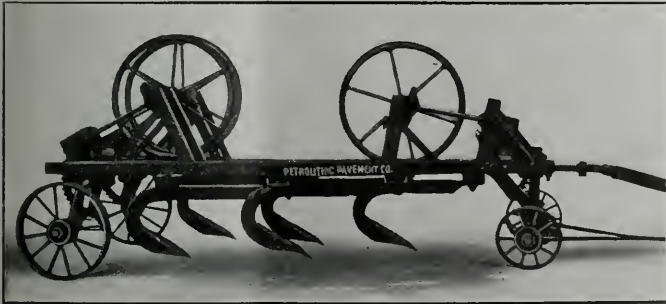

Let us tell you  
about the new

**Petrolithic Gang  
Road Rooter and  
Scarifier**

**THE PETROLITHIC CO.**  
345 P. E. Bldg.  
Los Angeles



Wherever good Contractors are,

there the Watson dump wagon is known.  
It's the most used dumping wagon in  
America, both by contractors and municipa-  
lities.

Only one single type of wagon is made in our big factory. All our time and money is devoted to doing one thing, and doing it well. Our printed matter is as high grade as the wagon. Ask for it.

**WATSON WAGON COMPANY, Canastota, New York**

The First Builders of Bottom Dumping Wagons

California Agencies: San Francisco, A. L. Young Machinery Co. 26-28 Fremont St.; Los Angeles, L. M. Davenport Co.



# “BITULITHIC”

The Ideal Boulevard Pavement

“BEST BY EVERY TEST”

☐ BITULITHIC has been adopted as the standard pavement in more than 200 cities, all of which give unqualified praise for BITULITHIC in the earliest as well as the latest cities. More than 15,000,000 square yards BITULITHIC PAVEMENT laid and contracted for in ten years, equal to over 850 miles of 30-foot roadway, shows the rapid increase of yardage and success of the BITULITHIC PAVEMENT.

☐ The following is one of many endorsements that shows that BITULITHIC is the most essential factor in real estate development:

315-316 Dickson Building,  
Norfolk, Virginia, May 7, 1910

Mr. George O. Tenney, Pres.,  
Atlantic Bitulithic Co., Richmond, Va.

Dear Sir:—

As per your request we are offering our opinion of the Bitulithic Pavement and its influence on the value of real estate.

We believe, from comparison with various kinds of paving, that it is the most durable and satisfactory, when constructed in a high grade manner. The Seventh Ward of our city has recently completed eleven miles of Bitulithic; a large expenditure, but justified by the increased tax return from the real estate. Real estate in this ward has increased twenty-five per cent. in value.

Very truly yours,

COLLINS & VAN DEN BERGH, INC.

(Signed) Paul T. Collins, President.

☐ BITULITHIC affords a superior foothold for horses in either wet or dry weather and is a sanitary, non-skidding resilient street pavement.

☐ BITULITHIC beautifies the city and enhances the value of property more than any other form of pavement.

==== Write today for explanatory booklets to =====

## WARREN BROTHERS COMPANY

59 Temple Place, Boston, Mass. 616 Laughlin Bldg., Los Angeles

==== (REGISTERED IN THE U. S. PATENT OFFICE) =====

“Bitulithic” “Warrenite” “Bitustone” “Bitrock” “Puritan” “Rockphalt”  
“Bituminous Macadam”

NOTE—Every city official in California reads Pacific Municipalities.

# Pacific Municipalities

OFFICIAL ORGAN OF THE LEAGUE OF CALIFORNIA MUNICIPALITIES

Entered at Post Office, Santa Clara, Cal., as Second-Class Matter

---

---

VOL. XXIV

TWELFTH YEAR

No. 1

---

EDITORS - - - H. A. MASON AND WM. J. LOCKE  
EDITORIAL OFFICE - NINTH FLOOR, PACIFIC BLD'G, SAN FRANCISCO  
PUBLICATION OFFICE, - - - SANTA CLARA, CALIFORNIA

---

---

## CONTENTS FOR FEBRUARY, 1911

---

The International Municipal Congress and Exposition at Chicago.....	5
Proceedings of the Thirteenth Annual Convention of the League of California Municipalities .....	6
Motor Propelled Fire Apparatus .....	6
The Use of Chemicals in Fighting Fires.....	10
Reducing the Fire Hazard in Municipalities .....	13
Department of City Attorneys.....	22
The Cameron Septic Tank Litigation.....	23
Oakland's High Pressure Auxiliary Fire Service System.....	29
Questions and Answers.....	35
Bitulithic Pavement Patents in N. Y. City.....	39
Editorial	
The Cameron Company Writes Letters .....	40
W. F. McClure for State Engineer .....	40
"Petro lithic" not "Bitulithic" .....	40
Trade Notes .....	40
What the Cities are Doing .....	41

---

Published Monthly. Yearly Subscription, \$2.00 in Advance. Single Copies, 25 Cents

ADVERTISING RATES ON APPLICATION

Address all Communications to "PACIFIC MUNICIPALITIES" Pacific Building  
San Francisco, California

# LEAGUE OF CALIFORNIA MUNICIPALITIES

Organized 1897

## — OFFICERS —

President	(Mayor of Berkeley)	BEVERLY L. HODGHEAD
First Vice-President	(Councilman of San Diego)	A. E. DODSON
Second Vice-President	(Mayor of Santa Cruz)	T. W. DRULLARD
Secretary	H. A. MASON	Ass't Secretary WM. J. LOCKE

## STANDING COMMITTEES

EXECUTIVE—Beverly L. Hodghead; H. A. Mason; S. C. Evans, Mayor of Riverside; Percy V. Long, City Attorney San Francisco; W. P. Butcher, City Attorney Santa Barbara.  
 LEGISLATIVE—W. F. Hyde, Palo Alto; J. O. Walsh, San Francisco; J. H. Strait, Redlands; F. H. Allbright, Red Bluff; B. L. Barney, Hanford.  
 JUDICIARY—C. N. Kirkbride, San Mateo; P. G. Sheehy, Watsonville; Stephen G. Long, Long Beach; R. E. Rhodes, Madera; Wm. J. Carr, Pasadena.  
 ENGINEERING—Chris. P. Jensen, Fresno; C. H. Pieper, San Jose; A. P. Noyes, Vallejo; R. C. Tumelty, Stockton; O. E. Stewart, Anaheim.

Secretary's Office and Headquarters of the League, - Pacific Building, San Francisco

## INFORMATION BUREAU

The League of California Municipalities maintains, in connection with the Secretary's Office, an Information Bureau where the officials of the municipalities belonging to the League can secure information on all subjects relating to municipal affairs.

## MEMBERSHIP

Alameda	Lindsay	Riverside
Albany	Livermore	Sacramento
Alhambra	Lodi	San Bernardino
Anaheim	Lompoc	San Buenaventura
Antioch	Long Beach	San Diego
Auburn	Los Angeles	San Francisco
Bakersfield	Los Banos	San Jose
Benicia	Los Gatos	San Leandro
Berkeley	Loyalton	San Luis Obispo
Biggs	Madera	San Mateo
Bishop	Martinez	San Rafael
Black Diamond	Merced	Santa Ana
Burlingame	Mill Valley	Santa Barbara
Calistoga	Modesto	Santa Clara
Chico	Monterey	Santa Cruz
Coalinga	Mountain View	Santa Maria
Colton	Napa	Santa Monica
Colusa	National City	Santa Paula
Compton	Nevada City	Santa Rosa
Coronado	Newman	Sausalito
Corona	Newport Beach	Sebastopol
Covina	Oakland	Selma
Crescent City	Ocean Park	Sierra Madre
East San Jose	Oceanside	Sisson
Elsinore	Orange	Sonoma
Emeryville	Oroville	Sonora
Escondido	Oxnard	South Pasadena
Etna	Pacific Grove	South San Francisco
Eureka	Palo Alto	St. Helena
Fairfield	Pasadena	Stockton
Ferndale	Petaluma	Suisun City
Fort Jones	Piedmont	Susanville
Fresno	Pinole	Tehachapi
Gilroy	Placerville	Tulare
Glendale	Pleasanton	Vacaville
Hanford	Point Arena	Vallejo
Hayward	Pomona	Visalia
Hercules	Red Bluff	Watsonville
Hermosa Beach	Redding	Whittier
Huntington Park	Redlands	Willits
Imperial	Redondo Beach	Winters
Jackson	Redwood City	Woodland
Lakeport	Richmond	Yreka
Lemoore	Rio Vista	

Every city belonging to the League of California Municipalities is entitled to a free copy of this magazine every month for each of its officials; if not received kindly notify the Secretary. See that your City is in the above list.



# PACIFIC MUNICIPALITIES

▲ Journal for Progressive Cities

VOL. XXIV

FEBRUARY 28, 1911

No. 1

## THE INTERNATIONAL MUNICIPAL CONGRESS AND EXPOSITION AT CHICAGO

PLANS are being arranged at the League headquarters in San Francisco, for carrying out the resolution adopted in San Diego to participate in the International Municipal Congress and Exposition to be held in Chicago next September. The managers at Chicago are making great preparations, and delegates from all over the United States and many foreign countries are expected to be in attendance. They have been informed of the resolution adopted at our San Diego meeting and space has been allotted for exhibits of the cities and towns of California. We trust that every municipality in the state will recognize this great opportunity presented here for advertising our state and the proposed World's Fair in 1915.

One proposition is to issue 50,000 books containing illustrated descriptions of the various public achievements of our cities and towns, such books to be handsomely finished so that they will be retained as souvenirs by those who receive them.

Another proposition decided upon is to secure photographs of public buildings, parks, streets, etc., from which we will make colored slides and have them thrown on screens with automatic stereopticon machines. These views may be used and exhibited again at the annual meeting of our League which follows in Santa Barbara.

The delegates who attended the convention at San Diego will recall the photographic exhibit made by Riverside. Similar exhibits can be made at Chicago, as several officers of our League will be in attendance and look after all photos, advertising booklets, etc., which the cities and towns may care to send. It is most important that this matter be taken up at once as there is much work to be done. There will be no charge for space at Chicago.

The idea of getting out 50,000 illustrated books and exhibiting stereopticon views, has been indorsed by President Hodghead and Secretary Mason, and will undoubtedly be indorsed by the other members of the Executive Committee of the League. Both of these features will cost considerable money, but the opportunity afforded for advertising our state so broadly at this time and arousing world-wide interest in the approaching World's Fair, is such an exceptional one that it would be a mistake not to take advantage of it. Fortunately, the amendment passed two years ago permitting municipalities to expend a sum for advertising purposes, will enable every city and town in the state to participate. Further information will be given upon application at the League headquarters.

PACIFIC MUNICIPALITIES  
PROCEEDINGS  
THIRTEENTH ANNUAL CONVENTION  
OF THE  
LEAGUE OF CALIFORNIA MUNICIPALITIES  
HELD AT  
SAN DIEGO, CALIFORNIA, November 15th to 19th, 1910

**MOTOR PROPELLED FIRE APPARATUS**

BY LOUIS ALMGREN, JR., Chief of the Fire Department of San Diego

The manufacturers of fire apparatus in this country have been carefully watching the development of the gasoline motor for the purpose of introducing it into the fire department service. A great deal of time has been expended in this field, to the end that satisfactory results have been obtained in perfecting some forms of motor propelled fire apparatus.

We know that most fires are discovered before they get much headway and the amount of damage they do depends upon the time it takes to get the apparatus with the means to extinguish it on the scene. The motor propelled apparatus for average distances to travel is quicker than the horse drawn apparatus, the greater the distance the more gain for the auto, and its ability at all times to get men and equipment to the fire with the least possible delay, proves beyond a doubt its great value in a business often involving the loss of life and property and hours of hard work; further, it is conceded that men who ride to fires on apparatus ready to go to work at the early stages of the fire are more valuable than men arriving some minutes later; it is a matter of record that most fires are under control within ten or fifteen minutes after they start.

The motor propelled combination hose and chemical apparatus has proven its superior worth over the horse drawn apparatus. It is considered by fire department officials throughout the country an indispensable fire fighting unit; some go so far as to say that it has obsoleted for use in certain communities the horse-drawn apparatus. It can be utilized to convey persons injured to hospitals; as a fuel wagon, fuel can be furnished to engines more expeditiously, especially when the engines are some distance from the base of supply; if necessary it can be dispatched to stations for the relay hose held in reserve, thereby save calling extra apparatus to the fire and jeopardizing the protection already minimized.

It has proven a great success in handling brush and grass fires. As a rule these fires occur in outlying districts remote from the fire limits, and the fact that the auto combination can get to this fire before it has spread to any great extent and extinguish it, return to station and be ready immediately for the next run, demonstrates the superiority of the auto over the horse-drawn apparatus for such service.

Another advantage while not in the fire fighting line, is important, the absence of horses from the station eliminates the extra labor for their care and the

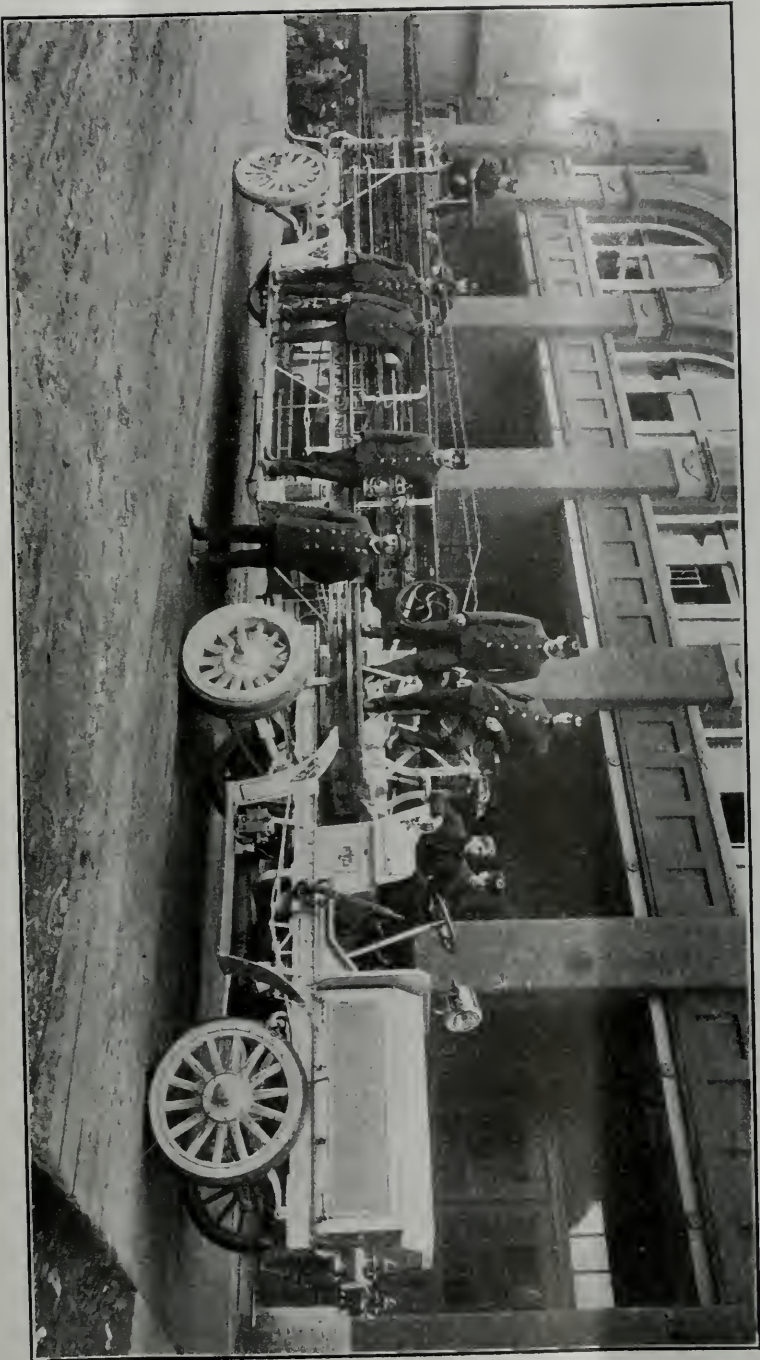

THE "SEAGRAVE" AUTOMOBILE COMBINATION CHEMICAL AND HOSE WAGON



risk of loss by injury or sickness, also the smell and noise which is an improvement in conditions appreciated by a fireman.

In housing the apparatus economy appears in favor of the auto apparatus, a space ten by twenty feet is sufficient to house it; no stalls, hay and grain rooms, or extra plumbing, heating or sewer connections are required.

The purchase price of the motor propelled apparatus will exceed the horse-drawn apparatus two or three thousand dollars, but this sum is insignificant when the cost of maintaining the horse apparatus is considered, and the fact that the auto will efficiently cover three times the territory that the horse drawn apparatus will.

In the case of a general alarm the auto apparatus can be concentrated for service expeditiously which is not true in the case of the horse-drawn apparatus.

The Vancouver fire department, one of the early adventurers in the auto field, after exhaustive tests under every condition imaginable, are equipping their entire department with motor propelled apparatus.

In cities where motor propelled apparatus is used, all alarms are responded to by an auxiliary squad dispatched in an auto vehicle, the ability of this squad to render efficient service makes it possible to maintain smaller companies in the outlying districts. This is an economy directly attributive to the auto vehicle and should not be overlooked in considering the advantages of the auto over the horse-drawn apparatus.

A variety of automobile fire engines have been put on the market, the most prominent of these is the combination engine and hose wagon, this is the only one that has given any degree of satisfaction as yet.

Recent tests by the Engineers of the National Board of Fire Underwriters demonstrated that the motor driven pumping apparatus in every case fell considerably below the rating claimed by the manufactures. So far the manufacturers have not succeeded in transmitting sufficient power from engine to pump to equal the pressure and volume of the steam fire engine of equal rating.

In small towns and outlying districts where small volume and fair pressure will suffice the combination engine has proven a success, it is also making an enviable record in cities where steep grades abound, on account of its ability to mount the grades at a high rate of speed and arrive at a fire before it has reached any magnitude.

The foremost manufacturers of fire engines in this country are expending large sums of money in an endeavor to perfect a type of motor engine for fire department use; they promise at an early date an engine that will equal in capacity the second size fire engine. Reports of recent tests made with these engines indicates that they will attain success at an early date.

Numerous attempts have been made to convert the ordinary touring car into a fire fighting machine, with poor results. It has been proven practically, that the stock car is in no case constructed to insure a factor of safety when required to meet the ordinary requirements of the fire department; weakness in construction renders it unreliable, and the cost of repairs necessary to keep the apparatus in serviceable condition proves expensive. The little difference in cost between the converted car and the car specially constructed for fire department purposes will soon be spent in the upkeep of the former.

The pneumatic tires of the stock car have not given satisfaction, the solid rubber tire seems to be the best suited for all needs, they will not deteriorate while standing idle like the pneumatic tire; and the possibility of delay through puncture or bursting going to or returning from fires is avoided.

One of the most important additions to the fire department equipment is the motor propelled aerial truck. This style of truck weighs thirteen thousand pounds, on account of this great weight it has not been practicable to fully secure the service intended for the truck when horse-drawn, motor propelled it has given satisfaction and fulfilled every requirement.

A motor propelled chassis attached to a fire engine is another improvement now being experimented with. From reports obtainable it is proving satisfactory.

The speed at which automobile fire apparatus should be driven when responding to alarms, is a matter that should be given careful consideration when preparing regulations governing the operation of same.

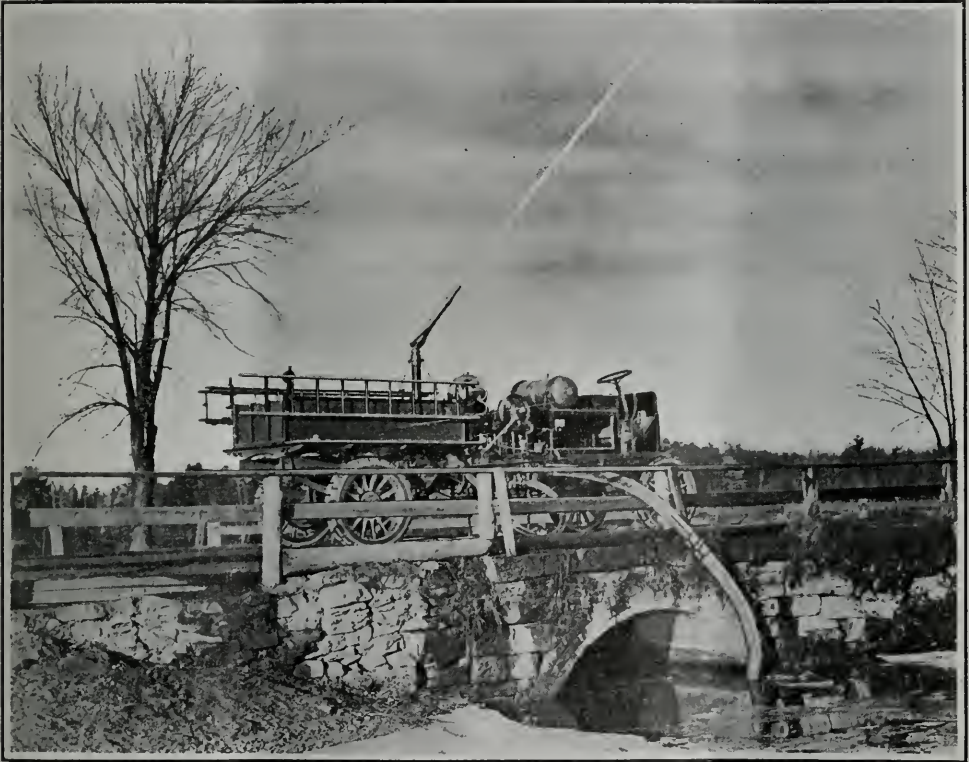

THE "KNOX" TRIPLE COMBINATION PUMP HOSE WAGON AND CHEMICAL ENGINE

There have been numerous accidents and loss of life on account of the high rate of speed at which the apparatus has been driven through the congested districts of cities.

For safety the automobile should never be driven at a greater speed than 25 miles per hour in congested districts and 30 miles per hour in the outlying districts. Speed can be greatly reduced, however, in the congested districts and still retain supremacy for the automobile apparatus.

The advent of the motor propelled apparatus into the fire fighting business indicates the early re-organization of the personnel of the stationing of apparatus in more centrally houses.

## THE USE OF CHEMICALS IN FIGHTING FIRES

This is a very broad subject, and the time allotted for my paper will not permit me to fully discuss the varied uses chemicals have been put to; so I will confine myself to a description of the use of chemicals in fighting ship fires.

In this port on the 16th day of June last, fire believed to have been caused by spontaneous combustion was discovered on the American Hawaiian freighter "Alaskan." This vessel was built at the Union Iron Works at San Francisco, in 1902. She is a twin screw vessel of 8607 tons register; steel construction throughout, with bulkheads and four compartments. Three decks extending the full length of each compartment are entered through seven hatches on the main deck.

Shortly after the vessel was moored alongside the wharf, smoke was seen coming from hatches 5 and 6, located aft of amidship and forward of the mainmast. The hatches were immediately battened down and the "king posts" covered with wet canvas to prevent a circulation of air fanning the flames.

The department responded to the alarm sent in from the ship, with two engines, one hose wagon and one combination chemical and hose wagon.

Arriving at the fire I immediately held a consultation with the Captain of the ship to learn the nature of the cargo. He informed me that his cargo was a miscellaneous one including calcium carbide stored in the lower hold in the after end of the compartment afire, also cartridge ammunition stored on the "tween decks forward of No. 6, hatch on the starboard side close to the starboard "king post."

The fire, which could not be seen, and the location only guessed at, presented a serious fire fighting problem; however, we decided to remove the covering from one corner of hatch No. 5, go down and inspect the conditions below.

It was quickly seen no adequate attack could be made from the deck. Men were lowered over the side of the ship; they reported that the heat was the most intense just above the water line. Several holes were bored through the side of the ship large enough to permit the entrance of the nozzles of the chemical hose.

It was discovered that the fire was raging a short distance from where the holes had been bored. Carbon-dioxide gas from the chemical tanks on the combination wagons was turned into the apertures. After several hours of work the lessening of smoke from the king-posts indicated that results were being accomplished. We continued to apply carbon-dioxide gas all that night—in the morning, the smoke from the "king-posts" had discontinued. A thermometer was lowered into the ventilator every thirty minutes and on each occasion registered 118 degrees Fahrenheit, an indication that we were succeeding in our efforts to lower the temperature. However, we continued to force gas into the hold until the following day, when the hatches were removed and an examination of the hold made. We were engaged at this work only a short time when the gas in the hold forced us to abandon our work and batten down the hatches. Steam was forced into the compartment continuously for ten hours and practically no results obtained.

Carbon-dioxide gas was again resorted to.



Resuscitating Apparatus



146 cylindrical tanks, each containing 500 cubic feet of carbon dioxide gas was obtained from the local Ice Company, and applied. This gas is compressed into tanks at a high pressure, which causes the gas to liquify. Upon being liberated to atmospheric pressure it returns to its original form, that is, carbon-dioxide gas.

It is my opinion that if this gas was used throughout the fire the water damage would have been a great deal less.

Our inability to secure any more of this gas compelled us to use the gas manufactured in the chemical tanks on the combination wagons. This is the same gas as that secured from the Ice Company, except that it is manufactured in the chemical tanks, two fifths of the volume in pounds consists of bi carbonate of soda, one fifth sulphuric acid and the remainder water.

The pressure generated depends upon the quality of the bi-carbonate of soda. A pressure of 200 to 250 is generally obtained.



THE "EVEREADY" SMOKE AND AMMONIA HELMET

Eight days elapsed before the hatches were again opened. Removing the covers two air blowers propelled by electric motors were lowered into the hold of the vessel and used to force the poisonous gases out through canvas pipes. Two blowers were placed on deck to force fresh air into the hold, to enable the men to work below moving cargo in their efforts to reach the fire.

On the lower deck where there was compactly stored several thousand bundles of cotton comforters and bales of hemp and jute. The carbon-monoxide gas became so strong that it was impossible for the men to remain below, so the hatches were again closed and the carbon-dioxide gas forced into the hold of the vessel a period of eight days; the temperature was finally lowered sufficiently to permit the removal of the hatches and the entrance of the men to the hold.

Forming the men into three reliefs and working each relief five minutes we made an extra effort to reach the fire.

While engaged in this work, man after man was overcome by the gas in the hold and brought to the upper deck in an unconscious state. So frequent were

these cases that it was found necessary to establish an improvised hospital on deck, with a Physician and three nurses in attendance at all times.

An investigation of the circumstances attending the asphyxiation of the men revealed the fact that the burning cotton and hemp formed carbon-monoxide gas, this gas is exceedingly poisonous, when inhaled by human beings it forms a chemical compound with the hæmoglobin of the blood, thus preventing the latter from carrying oxygen which is necessary for supporting life. On account of the small amount of carbon-monoxide gas present and the slow action of the gas it was possible when a man was overcome to raise him to the upper deck for treatment before the action of the gases resulted seriously. Several of the men, however, had narrow escapes from death.

In all cases oxygen was administered, and when the person revived sufficiently, he was given all the milk he could drink, this treatment worked successfully and the men recovered with apparently no ill effects.

A number of the men after several hours in the open air descended into the hold again and assisted in the work of moving cargo.

Sufficient cargo was finally removed from the hold to enable us to reach the calcium-carbide. After removing the carbide two second size engines were brought into service, and with two lines of 2½ inch hose, with shut off nozzles lead below and placed directly on the fire it was extinguished in a very short time.

It will be seen from the foregoing that the most effective extinguisher used in this fire was the carbon-dioxide gas. No damage could be directly attributed to it when applied in gas form, and only slight damage was done when applied in water solution.

The carbon-dioxide gas when applied to the cargo would extinguish the flames running wild, but would not work effectively on the smouldering bales, this is accounted for from the failure of the gas to penetrate the bales and smother the fire.

The oxygen retained within the bales offered fuel to the smouldering cotton, and when the use of the carbon-dioxide gas was discontinued and the hatches opened, the oxygen entering would again add fuel to the smouldering cotton causing the fire to increase.

The sulphur-dioxide gas applied with a Clayton Fire Extinguisher, did not prove effective and on account of its poisonous properties its use was discontinued. Some damage was done by this gas in discoloring dry-goods, etc.

The steam that was forced into the hold had little or no effect, considerable damage was done by the steam condensing and settling on metal goods causing them to rust.

The Chemical Apparatus used at this fire, were three combination chemical and hose wagons and one chemical engine. Two with forty gallon tanks, are with two thirty-five gallon tanks and one with two eighty gallon tanks and sixteen 3 gallon fire extinguishers.

The total amount of chemical used was 215,000 gallons, or approximately 608,500 cubic feet of carbon-dioxide gas.

It was fully demonstrated at this fire that the use of chemicals in fighting ship fires can be greatly improved upon.

The ships cargo consisted of 8670 tons of miscellaneous freight, or in other words 400 freight car loads.

The full cargo was valued at \$2,000,000, and the ship \$800,000, a total value of \$2,800,000; the total loss to cargo was approximately \$300,000 or about 11% of the total amount involved.

## BEFORE THE GENERAL BODY

AFTERNOON SESSION, WEDNESDAY, NOVEMBER 16, 1910, 1:30 O'clock, P. M.

The meeting was called to order by the President, who announced as the first subject on the afternoon's program the paper on "Reducing the Fire Hazard in Municipalities", by George M. Robertson, Engineer of the Board of Fire Underwriters' of the Pacific, of San Francisco, who was introduced to the audience by the President.

MR. ROBERTSON. Mr. President, and Gentlemen: I hope that the profit you will derive from this will be commensurate with the size and dignity of the audience. I will endeavor to do my part.

## REDUCING THE FIRE HAZARD IN MUNICIPALITIES

---

MR. ROBERTSON. When we consider that the fire loss in this country for one year, 1907, which is selected because it is fairly representative in that respect, was about \$215,084,709.00, it is quite evident that any step taken in mitigation of such losses is not only commendable, but of prime importance.

The United States Geological Survey, under the direction of the Department of the Interior, has gathered statistics concerning losses by fire, and published them together with conclusions reached from their study, in bulletin No. 418, entitled "The Fire Tax and Waste of Structural Materials in the United States". From this publication, it appears that reports were received from 2,976 cities, villages and rural districts in the United States, having an aggregate population of 35,854,900, in which the total fire loss for the year 1907 was \$89,995,795 00, making a per capita loss of \$2.51. Fire occurred in 165,257 buildings, 1449 persons perished, and 5,654 were injured.

From statistics compiled by the National Board of Fire Underwriters, it appears that the fire loss for the last 33 years is \$4,484,326,831.00 This is absolute waste, entire destruction, and is evidently a severe drain upon the resources of the country.

In addition to the amount just stated, an equal amount has been paid out for fire protection during this period, bringing the total expenditure, due to fire, for 33 years, up to \$9,000,000,000.00. Taking the year 1907, again, as typical of the years generally, the per capita loss was five times as much as it was in any European country, and about eight times as much as in any of the six leading countries of Europe.

While it is evident that much of the difference between the fire loss in Europe and that in our own country is due to the difference in construction and equipment of buildings, lack of attention to common hazards, absence of precaution in storage and use of inflammables and high explosives, and inadequacy of laws and ordinances, a good part may be attributed to what Mr. Goddard, in his address as President of the National Fire Protection Association, calls the hazard due to a republican form of government.

By this I understand Mr. Goddard to mean the hostility of the average American citizen to restraint of any kind, his impatience in the face of restrictions upon his activity, and the readiness he shows in opposing any regulations whatever, but particularly any regulation of his business.

A great deal can be done toward lessening this particular hazard, and thereby



decreasing all the others, by systematic and persistent instruction. By this I mean gathering statistics, arranging them so that they will command attention, and keeping them before the people; for while the American citizen is impatient of restraint, he is generally open to conviction, and once convinced may be relied upon to do the right thing. If it were not that the public school course is already overloaded with such a variety of subjects, it certainly would be desirable to give in them some instruction as to the causes of fire, and some advice looking to their prevention; but I doubt very much whether that can be done at present.

Coming now to the subject: I will direct your attention first to the various ways in which structures may be made, and their advantages and disadvantages. As wood is the cheapest and most widely distributed building material, the large majority of buildings in this country have been made of it, and its use is responsible for much of the fire loss. The only way to lessen the hazard inherent to this class of construction is to keep the buildings as far apart as possible; build them with the smallest possible number of concealed spaces, attics and communications between the various floors,—this last including the space between studding in the walls; and to make sure that all fire-places and flues, and all appliances for heating, ventilating and lighting are made of the best material, and installed with the greatest care. Wooden roofs are especially subject to fire, and should be well made in the first place, and kept in repair and well coated with some fire resistive paint.

Wooden ranges, that is, solid rows of wooden buildings, are likely to cause extensive fires, and should be broken up into several parts by brick or concrete walls having no openings, and rising well above roof.

Wood, even when used in the most careful manner and with the greatest precaution, should be restricted in its use to dwellings of moderate dimensions, farm buildings and sheds, or other small structures with plenty of space around them. Its presence in large municipalities increases the likelihood of wide spreading fires, particularly when roofs are of the same material.

A better class of structures comprises those buildings having exterior walls of brick, stone or concrete, and floors of wood supported by wood posts with wooden joists and girders, or by unprotected steel columns and girders. At first glance the steel columns and girders would seem to be better than similar wooden members, but the strength of iron decreases so rapidly as its temperature increases, that a hot fire under an unprotected steel or iron member usually causes it to yield and allow the floor above to fall, sooner than do the wooden posts and girders of the dimensions customary in such buildings. The difference in point of resistance to fire between a poorly constructed building of the type, just mentioned and a well-built building of the same type, is very great; when the posts or columns are small, floors thin, stairways unenclosed, and windows made with wooden casings and sash glazed with ordinary glass, such a building is in reality little more than a huge, tight stove, and burns readily and fiercely.

On the other hand, when the posts are of generous dimensions, the floor three inches or more in thickness, made of two layers of wood with some continuous water-proof material between them, and resting on joists not smaller than six inches in any dimension; when the stairways and elevators are enclosed in brick shafts with fireproof doors; and when the windows are closed by wired glass and steel sashes in steel frames, you have an excellent structure well adapted to resist fire and well arranged for protection of the most advanced type.

Buildings of this general class may be found with the most widely divergent capacities for resisting fire, from the flimsy, veneered building at one end of the scale to the simple but scientifically built mill construction at the other. The

veneered building has some slightly greater capacity for resisting exposure fires than has a frame structure, but once ignited is more likely to collapse, frequently with injury to firemen. The mill constructed type of building is the best of the class employing wood in the important parts of the structure.

The following description of some buildings of a bad type of this class is taken from Insurance Engineering:

### NEW YORK TENEMENTS

"Looking at one of these tenement Buildings in course of erection, one is reminded of a tangled mass of toothpicks.

From ground floor to roof, there is a forest of 2 in. by 4 in. studding, supported by tiers of yellow pine or spruce floor beams, all of which are later boxed in by  $\frac{7}{8}$  in. flooring and plaster on wooden lath. The result is a five or six story brick box, divided into a host of little rooms, closets, narrow halls and stairways. Then these little box-like rooms are filled to overflowing with tenants. The whole structure is a fire-trap, and disgrace to our city. We have miles of such structures which are a constant menace to our city's safety. Fires in them are of daily occurrence, and loss of life is frequent. As a matter of fact, the loss of life at these fires is so common the record in the daily papers scarcely causes comment."

You observe that this is descriptive of a building in New York, but I can assure you that "there are others."

Retaining now the brick, stone or concrete walls and discarding all wood but that in floors laid on concrete and used in doors, casings and interior trim, you have the most general type of well built mercantile structure. This structure has nothing inflammable in it but the wood mentioned and the contents; if the latter are not too combustible, or too congested, this constitutes an excellent insurance risk, and is a good step in the direction of municipal improvement.

The final and best type of fire resisting building, which has been evolved by slow degrees, is the modern steel framed structure with all steel members protected by not less than two inches of concrete, concrete floors, steel frame and wire-glass sash, stairway, stairway and elevator wells in brick or concrete shafts, and all wooden structural parts eliminated, their places being taken by metal; metal trim and even metal furniture now being found frequently. In this structure is attained the highest type of building for fire defensive purposes; it reminds one somewhat of the modern steamer, which by reason of cellular construction may be punctured by rocks or by collision with other vessels, and still retain sufficient buoyancy to keep her afloat, although one or more compartments may be flooded. In this advanced type of building the contents of any one part might be entirely consumed without setting fire either to the building, or to the other contents.

I read from a New York paper:

"What might have proved the most colossal flaming torch in history was reduced to a fizzle in the Singer Tower fire Thursday purely by foresight against such eventuality on the part of the architects of the structure.

"What transpired was highly spectacular, not on account of what happened, but on account of what might have happened, but didn't. Had the interior finish of the building been of wood work, it would have meant a spectacle that all the millions of people of New York and for miles around would have rioted to see.

"The fire, starting as it did in the small hours of the morning, on the twenty-sixth floor, would have spread to the upper floors, the great pile would have become a giant chimney, and the sixteen upper stories as susceptible to the flames

as the head of an enormous match; but, for all the ferocity of the fire in the room in which it started, it could get no further—all the damage it could do was to blister the inside finish of the doors and trimmings of steel."

Intimately connected with the question of construction is the matter of heating, lighting and power, involving the use of electricity, gas, gasoline, coal oil and other derivatives of fuel oil together with the fuel oil itself. The hazards of kerosene are well known, and do not call for special notice; ordinary illuminating gas has also been in use sufficiently to be well understood. Gasoline and electricity are in a class by themselves and are chargeable with a great many fires. Those from gasoline being principally found in the smaller municipalities remote from sources of electric supply and not sufficiently large to warrant the introduction of gas plants.

The estimation in which gasoline is held as a cause of fire may be understood when known that in San Francisco its use for heating and lighting is prohibited by ordinance, and the only users of this fluid are cleaning establishments and users of automobiles. A great deal of the danger attributable to the use of gasoline may be avoided, however, by the use of proper apparatus for its consumption and storage, and by providing for such ventilation in localities where it is used as will prevent the accumulation of gas. Gasoline gas is heavier than air and as gasoline is exceedingly volatile, any open or leaky container is likely to permit the escape of sufficient gas to fill a low place or a room or a basement with an explosive mixture of gas and air, and cause a very serious explosion. The hazard of electricity is now so well understood, and the precaution to be taken in generating, distributing and consuming is so well known, that fires due to electric causes may be set down, for the most part, to recklessness or neglect.

Taking at random some instances of electric fires, of which the causes are known, I note the following:

*Heat from incandescent lamps:* "A conveyor pit in a paper mill was lighted by incandescent lamps without lamp guards; conveyor carried waste paper cutting to a digester in another building, and was over 100 feet long with wood flooring over it, wooden conveyor constructions and wood chutes. Fire started from unemptied paper in a stationary conveyor in contact with lamps. Loss, \$50,000 and one life."

*Defective wiring exposed to moisture:* "A large eight story building wired with weatherproof wire in wood moulding, laid in part under flooring in cement. Fire started on fifth floor in closet, due to short-circuiting of the weatherproof wire in moulding because of water from floor above. Loss, \$150,000."

"Link fuses not in cabinet, or old-style cutouts with link fuses, were installed on the ceiling of the basement of a large department store just over a wrapping table. The fuses were not in cabinet, as is required. For some reason the fuses blew and hot fuse metal, falling on some papers on the table beneath, set fire to same; fire spread, with a loss of \$60,000."

Citing more briefly some more fires, I find these headings: Home made bed warmer, flat-iron fire, improperly made joints in contact with metal ceiling, fuse in canopy, \$4210. Telephone wires shorted on electric light wires, and many others, all of which were avoidable and should have been avoided. The remedy for this class of fires is obvious. It lies in the firm control of the business of installing electric apparatus, and the rejection of all unsuitable material. The strict application of the National Electric Code would eliminate most of these fires.

It takes all kinds of people to make a world;



It takes all kinds of business activity to make a city; and many of those activities involve hazards which are unavoidable; some of these are:

- Bakeries—hazard of ovens, fuel cooking stoves, lard pans, etc.
- Bleaching, dye and print works—use of heat, chemicals, storage and use of naphtha, benzine and other inflammable substances.
- Breweries—malt roasters, malt mill, brew kettles, van varnishing.
- Candy factories—cooking furnaces and kettles, steam table, starch rooms.
- Cereal mills—dusters or cleaning machines, dryers, grinders.
- Clothing factories—waste clippings, type and method of heating sad irons, control of gas.
- Drug risks—compounding, storage and handling of chemicals.
- Foundries—melting furnaces, fuel storage.
- Hat factories—dusters, drying, alcohol reclaiming, finishing irons, singeing, steam tables.

Metal works—acids, forges, furnaces of enameling and tinning, oil tempering, japanning, painting and varnishing, dip tanks, burners, benzine and gasoline for cleaning, etc.

Printing, binding and lithographing—with use of benzine and presence of waste paper, oily waste and rags, lamp black, etc.

Shoe shops—using and storing rubber cement, naphtha and various mixtures of it, wax filling for shoes, shoe dryers, lamp black, polish making.

Steam laundries, with their dryers, etc.

These are some only of the numerous occupancies which cause fire; to them may be added restaurants, hotels, theaters and department stores, these last mentioned being particularly interesting on account of the hazard to life as well as to property.

I find in the quarterly bulletin of the National Fire Protection Association this very interesting tabulation of the causes of 269 fires in department stores:

- FIRES

	No. of fires	Per cent of fires.
Occurring in waste or rubbish of various kinds	70	26
Unknown	65	24
Defective electric wiring, many from temporary wiring in show windows	49	18
Employee fires, due to carelessness of store employees, mechanics, etc., with a few due to carelessness of shoppers	31	12
Exposure	17	6
Kitchens connected with restaurants or candy kitchens	11	4
Spontaneous combustion in furniture rooms	5	1
Incendiary	1	
K. O. lamp exploded	1	
	269	

Please note in the figures pertaining to fires in department stores the large number of fires attributable to waste or rubbish of various kinds, and the large number classified as due to unknown causes; these two classes comprise fifty per cent of the entire number; they are really due to the same cause, carelessness and ignorance. When one considers the loss of life likely to occur by reason of a fire

in a crowded department store, these figures are startling; frequent and rigid inspection would materially reduce the number of these occurrences.

I think that this brief statement of the case will suffice for the construction, and for the causes of fire due to the various ways in which buildings may be occupied.

Remains now the question, Having a fire, how can it be extinguished?

There is no better agent for putting out fires than water, and water will always remain the best extinguisher for general application. It may be thrown from a bucket, ejected by gas pressure from a chemical extinguisher, or thrown from a hose nozzle, or other device.

The water is supplied to hose lines, or other devices, either from a fire engine, which is nothing but a movable pump, or by pressure in the street main resulting from the force of gravity, or from stationary pumps. The best source of water under pressure is a gravity reservoir, at a sufficient height to insure sufficient pressure for the city under consideration, 80 lbs. per square inch at the hydrant being generally considered as standard, and being quite sufficient for towns where the highest structures are not more than four stories in height. Where the buildings are of greater elevation, however, the pressure will have to rise accordingly, and then the hose streams will necessarily be of little value when used from the street; they will have to be taken from stand pipes of suitable dimensions installed in the buildings, or from water towers in the street. If it is impossible to have sufficient water for fire purposes stored in reservoirs, the next best source of pressure is a stationary pump of good design built with extra strong parts and large water ways so as to stand the strain of idleness coupled with sudden starting and general abuse.

The fire engine is the next, but is not as good as either of the sources mentioned, its only function being to take the water from the street main and raise the pressure. There is one case, however, in which fire engines, or movable pumps, are absolutely necessary, and that is where there are no street mains and where the water storage for fire purposes is in cisterns. These are found chiefly in the smaller communities, although there are quite a number in San Francisco in the districts where disturbances of the mains due to movements of the earth have shown the desirability of having some water in containers not subject to this hazard.

I may say, though, that at present it is generally conceded that the high pressure main for fire purposes only is the most satisfactory and most up-to-date method of supplying water for fighting fire, the most advanced exponents of the art of protection from fire being in accord to diminish as much as possible the use of movable apparatus, and to confine that apparatus principally to hose.

Something has been said about other devices for distributing water. These are the so called automatic sprinklers, which consist of small outlets, usually one-half inch in diameter, placed directly on the pipes, and ready as soon as unsealed to distribute water upon the fire. They are closed by a device depending upon the heat itself to open it, solely, and have the merit of distributing water only where it is needed and of doing it at once. A well sprinklered building of ordinary occupancy is very unlikely to burn; in fact, if the sprinklers are supplied with water under good pressure, they do not fail to extinguish fires, and they are the very best means known at present, to control fires.

Some kind of an alarm or means of announcing that a fire is in progress is necessary in every community, and these alarm systems vary in complexity and reliability from a call from the nearest telephone to the alarm given by an ap-

paratus installed for that purpose, and causing a signal to be made at fire department headquarters, or struck upon a bell that everybody may hear. The most complete and trustworthy device of the kind is the non-interfering, successive type, which means only that two or more people may turn in alarms for different fires, or for the same fire but at different stations, and all of the signals will be given without interfering with each other, and in the order in which they may be turned in.

Everything that has been said so far is the A, B, C of fire protection, the commonplaces of the art; but they are as true as they ever were, and must be taken into account and form the basis or starting point of all efforts to reduce the fire hazard.

It follows, then, that the community should:

1st. Control the construction of buildings within its borders, making them, as far as may be, incombustible. This is done by making and strictly enforcing building ordinances suited to the locality. The National Fire Protection Association publishes a typical ordinance of this kind.

2nd. Regulate the occupancies and keep those likely to cause fires at a distance from congested districts, where large values are stored in small areas.

3rd. Provide the best systems possible for supplying water for fighting fires, this being done, as we have seen, by mains for fire purposes only, kept filled by water under pressure from large reservoirs feeding the mains by gravity, or mains filled from stationary pumps designed for *heavy duty* and *much abuse*, or mains under low pressure, when movable pumps must be employed for throwing the water upon the fires.

4th. Maintain and keep in the highest state of efficiency such apparatus as may be needed to get the water upon the fire in the shortest possible time; this apparatus should be housed in fire-proof structures, remote from bad exposures, and so distributed about the town that any quarter may be reached promptly.

The lack of this precaution caused us, in the San Francisco fire, to lose the services of our most efficient and valuable auxiliary, the late Chief Dennis Sullivan. He was living in a flimsy building, which collapsed promptly, inflicting injuries upon him from which he died. It is impossible to proceed without saying something in testimony of this man's great qualities. He was as good a fireman as this country has produced, and still while reserved, earnest and reticent, he was a polite and attentive listener, and most ready to understand what was required, and help in its execution; the loss which San Francisco sustained in his death can never be remedied. It is impossible to fill the place left vacant by a man like that, and it has not been filled.

To return to the consideration of the safety which should surround all apparatus which must be used for fighting fire. I call your attention to the common practice in small municipalities of taking steam for pressure pumps from planing mills, saw mills, or other occupancies which are themselves generally greater hazards than anything in the town itself; the location of small, perishable wooden hose houses and engine houses alongside of restaurants, laundries, or frame ranges, and in general the entire neglect of precautions for maintaining the safety of things which should be safe at all times. These structures should be, if possible, made of concrete or brick, and contain no wood or other burnable material, except the apparatus itself.

5th. Maintain some kind of a fire department varying in number according to the resources of the community, but, at all events, to have at least one man having a thorough knowledge of the town, the apparatus under his care, and the



things to be done immediately upon an alarm. One such man in a town unable to maintain a full fledged fire department, would be of very great value in taking control of and directing the measures to be taken in controlling the fire. The men in the fire department should be of the very best kind, as they have to stand a kind of strain which it takes a good man to withstand,—the strain of being always ready for something which may never occur. Too much care cannot be taken in the selection of firemen, or in care of them after they are selected. They are expected to render the highest type of service to the community, and should receive from the community care commensurate with the expected service.

The question whether the department should be a paid department or a volunteer department is always up for consideration, and its solution depends, of course, upon the pecuniary ability of the community. My own impression is, that few men and good ones should be employed, and paid liberally, rather than a great many half-paid men; and even if volunteers are relied upon to handle the hose, and do other work attendant upon fighting fires, there should be one efficient, well-paid head to direct it.

6th. Cause a continuous and careful inspection to be made of all hazardous occupancies, and of alleys, back yards and lots in which rubbish accumulates, and generally all places where material can be lodged and forgotten, ready to spread a fire when one occurs. This inspection is now carried on almost entirely by various insurance bodies; their efforts are, of course, not entirely altruistic; but they perform a service which is very little recognized, and hardly appreciated at all. I will ask you assembled here to bear this particularly in mind, that the inspector should be treated well when he behaves well. He is of great value to you; his position is not pleasant; he has a great deal of disagreeable work to do; he is exposed to all kinds of hazards, and all kinds of unkindness and disheartening treatment, frequently abuse. This is absolutely unjust and wrong. I hope that you will endeavor to remedy it to the extent of your ability to do so.

And please bear in mind that each town makes its own insurance rate, in a much greater measure than people usually think. A town which is well supplied with water, not congested, and particularly which is kept clean, will always have a better rate than one in which these features are neglected; and it is folly to expect people to agree to pay an indemnity in case of fire when no care is taken by those to whom the indemnity is to be paid, to prevent a fire.

Gentlemen, I hope I have touched upon the important points in this matter. I have not gone into the technicalities of street mains, fire hydrants, and things of that kind, because we must stop somewhere, and the subject is inexhaustible. If I have said something which will prevent even one fire, or save one life, I am extremely happy, and I will take great pleasure in answering any questions which you may see fit to ask. I will say, that if any gentleman here wishes to get a copy of any of the papers or ordinances to which I have referred, or of any of the pamphlets of the Fire Association, if he will kindly write to me in the care of the Board of Fire Underwriters of the Pacific, San Francisco, he will receive it just as quickly as we can get it to him.

MR. T. W. DRULLARD, of Santa Cruz. Mr. President, before we proceed with the discussion, I move that a vote of thanks be tendered the essayist for the very able and entertaining paper that we have just listened to.

The motion unanimously prevailed.

MR. W. F. McCLURE, of Berkeley. I would like to ask Mr. Robertson what particular value he attaches to the matter of fire limits in a city.

MR. ROBERTSON. A very considerable value, Mr. McClure, and I am sorry

I did not mention it. In making it compulsory upon people to erect noncombustible buildings within certain limits, and keeping certain hazardous occupancies out of those limits, an extremely valuable thing is done, and it is, of course, a part of the fire ordinance. It will naturally find its place in the fire ordinance, and, as a matter of fact, is always in such ordinances. The use and storage of gasoline, for instance, should be absolutely prohibited within certain limits, and, if it were possible to compel the construction of a block of refractory buildings dividing the town crosswise, it would be almost impossible to burn up more than a quarter of it.

MR. HYDE of Palo Alto. What would you do in a case like this: After the earthquake, the town in which I live contained a three-story wooden building in the heart of the business district that was so wrecked that it ought to have been removed. Owing to political influence, the owner succeeded in getting a permit to restore it for one year. That is four or five years ago, and he never has removed it—he still has political influence and a newspaper. What would you do with a man like that?

MR. ROBERTSON. I would hate to tell you in this presence what I would do with him.

MR. WIELAND, of Berkeley. I was called upon professionally to examine some buildings recently in a large city up in the valley, where there had been the collapse of a structure, which frightened the people very generally, and there were buildings in the course of repair that were in a very bad shape, and they were allowed to tear down the walls and were intending to rebuild the walls as party-walls. When that one scare occurred, the Fire Chief got desperate and condemned the structure, and I was called in afterwards to see whether the Fire Chief was right. He was right in it, and I said so after I had been on the job five minutes. If you have such conditions as that, I say put it up to the people. You can agitate the matter, you can go to your Chamber of Commerce, or some similar place, and hammer away at it. Don't get discouraged because the man has a political pull. If you are saving one life, you had better incur the enmity of a hundred people. I would like to elaborate on what Mr. Robertson stated about the fire engine-houses. The necessity for having the Fire Department at hand and in good shape at all times must be apparent to everyone. In San Francisco, the Fire Chief was killed at the time of the earthquake, as you know. A fireman also was killed there. At San Jose, the captain of one of the fire trucks was killed. No one can say that in San Diego there are no earthquakes to occur. The same thing is true in other places in the State. Of course, we cannot all have high-pressure systems—there is nothing better, of course. But even with high-pressure systems, you will want a building in which to house your men and your hose carts. Those buildings, by virtue of necessity, are located in thickly populated districts. You may have a frame-house on either side of the fire-house. You may have a tall brick-house upon one side and the condition the gentleman has just mentioned may obtain there, just as it has obtained in this other place where a number of buildings I saw were taken down. The brick chimney or the fire-wall may fall from a great height onto your fire engine-house, which is a very much lower height. That may result in killing the chief, a fireman, or the men upon whom you depend. In the nature of things, you look to the general in command. If he is a good man, he will have had his force well trained, to act, perhaps, independently. But we look to head authority in any event. Now, you have fire engine-houses to contain only certain apparatus. You do not extend that—you would rather extend the number of your houses. If your ideas as such

as will permit you to put in fireproof fire engine-houses for the protection of the apparatus, hammer away at that—get your Chamber of Commerce or other people to stand with you in what you want to bring about as an official. Don't be afraid to initiate something. Don't wait until somebody comes along and tells you to do certain things. See that you have an opportunity to build fire engine-houses of an indestructible character.

**THE PRESIDENT.** I would get the City Council together and pass a first-class building ordinance, modeled, perhaps, after the lines of the Los Angeles ordinance, or after that of the little town that I come from, and then I would never make an exception to it. That was the hardest thing we had to do after passing our ordinance, to deny people special privileges in order to get around it. When the building deteriorates to be of only a certain percentage of its original value, or it burns down or falls down, don't under any conditions allow its rebuilding. That is the only way you will ever accomplish any thing in that particular direction.

**MR. DRULLARD.** I understand from the question the gentleman from Palo Alto asked, that it was not through any fault of the ordinance, but it was from lack of political pull that they could not accomplish what was desired in his town.

**THE PRESIDENT.** If that is the case, get out and do politics yourself the next time, and see that you elect the right men.

**MR. B. L. BARNBY,** of Hanford. I don't know that I have any questions, but I would like to emphasize a little what the gentleman has said in his paper in regard to the system of fire mains, and to show the benefit that has been received by our town in that direction. Speaking along the lines of the steam-power being contained in planing-mills or other similar places, for several years our fire steam-boilers (we have the Holly system for our fire mains) were contained in a flour mill. Within two years we have erected a boiler-house, fire boiler house with new boilers, in which we keep up steam continually. Wherever we have been able to reach a given locality, our insurance has been reduced over 25 per cent. I simply speak of that to show you the benefit that the people derive from efficient fire protection.

**THE PRESIDENT.** I am informed that Mayor Hodghead has some information that will be of interest to the convention concerning the election yesterday in San Francisco.

**MAYOR HODGHEAD.** I have just received a message that will be of interest in connection with the discussion we had yesterday on the Commission form of government. It was stated on yesterday that San Francisco was voting on some charter amendments, and one of the amendments is the question of whether or not San Francisco would embody in its charter the plan of election which is followed in Berkeley, which was attempted to be explained yesterday, and also that there was some doubt as to whether it would carry, because there was a decided opposition coming from a particular element in San Francisco. This message states that the Berkeley plan of election carried in San Francisco yesterday by a vote of 4 to 1. (Applause).

## DEPARTMENT OF CITY ATTORNEYS

WEDNESDAY, NOVEMBER 16, 1910. 5 P. M.

PRESIDENT W. P. BUTCHER, of the Section, introduced Mr. William K.



White, of San Francisco, stating that he would address the section on The Cameron Septic Tank Litigation.

MR. LOCKE. It may be advisable to precede Mr. White's talk with a brief statement of the conditions under which Mr. White, or rather the firm of Miller & White, was employed, and, if I may be permitted, I will, in a few words, give a brief explanation of the circumstances which brought about that employment. Some seven or eight months ago, we were notified by the College Park Sanitary District, which is located close to the city of San Jose, that they had been served with notice from the Cameron septic tank people, through their attorney, that a septic tank they had constructed was an infringement on their patent, and a demand was made for payment of a sum of money as royalty. They corresponded, I believe, with Mr. Osborn of Santa Cruz, and he in turn submitted the matter to the League. To be brief, the result was that a meeting was called and held in San Francisco, and an organization was perfected, which organization it was assumed was under the auspices of the League of California Municipalities. Committees were appointed, to raise money and engage the services of counsel, if in their judgment it was deemed advisable, and this committee, of which I am a member, finally did, after considerable deliberation and investigation, engage the services of Miller & White, the well known patent attorneys, having offices in San Francisco and New York City. They are regarded as being among the leading patent attorneys in the country. This is Mr. White, of that firm, who has been handling the matter for the league. I might add, also, that this committee asked the various cities to contribute an amount equal to their annual dues to the League, for the purpose of defraying the expenses of the litigation that might be necessary. It is possible that we shall again have to ask for financial assistance in this matter. Mr. White will, I trust, in his remarks, dwell upon that feature of the case.

## THE CAMERON SEPTIC TANK LITIGATION

---

WILLIAM K. WHITE of San Francisco, Gentlemen: On October 3, 1893, there was issued to Cameron and his coinventors United States letters patent, No. 634,423, for "Process of and Apparatus for Treating Sewage." This patent is generally referred to as the "Cameron Septic Tank Patent."

In a suit brought by the Cameron Septic Tank Company against the Village of Saratoga Springs, the United States Circuit Court of Appeals for the Second Circuit adjudged the process claims of this patent to be valid, and construed them so broadly that it is doubtful if an efficient septic tank can be constructed which would not infringe one or more of such claims. The decision of the Court of Appeals is reported in Volume 159 of the Federal Reporter at page 453. The defendant filed a petition for a rehearing and, the same having been denied, thereafter petitioned the Supreme Court of the United States for a Writ of Certiorari, which petition was likewise denied.

Prior to November 8, 1909, the Cameron Company commenced a suit in the United States Circuit Court for the Southern District of Iowa against the City of Knoxville. In this suit, the defendant filed a plea setting forth that a British patent had been issued to Cameron for his septic tank and that such patent expired on November 9, 1909; that, therefore, under Section 4887 of the Revised Statutes, the Cameron United States patent in suit expired with the expiration of the British patent for the same invention. This plea was sustained by the court

and the suit ordered dismissed. From such order an appeal was taken to the Supreme Court of the United States and the same is now pending.

I have been informed by the Clerk of the Supreme Court that such appeal would not be reached for hearing until 1912 October term of the court. It is, therefore, probable that the question whether or not the Cameron United States letters patent expired on November 9, 1909, will not be authoritatively determined until the year 1913. In my judgment, no circuit court would be willing to pass upon this question while it is before the Supreme Court for determination. I am also of the opinion that the attorneys for the Cameron Company take the same view of this matter and, therefore, it is not probable that any new suits will be brought by the Cameron Company until after a favorable decision is handed down by the Supreme Court in the suit against the City of Knoxville.

As to whether such decision will likely be favorable or unfavorable to the Cameron Company, I can only state that the weight of authority is on the side of the defendant's contentions, and for that reason I am inclined to believe that the Supreme Court will hold that the Cameron United States patent expired with the expiration of the British patent on November 9, 1909, assuming the two patents to cover the same invention.

In view of the circuit court decision adjudging the Cameron patent to have expired on November 9, 1909, it would seem unnecessary at this time for any user of a septic tank to pay any attention to the charges of infringement made by the Cameron Company. Of course if the Cameron Company were willing to compromise, on some reasonable basis, its claims for damages, I would, in view of the uncertainty as to what the Supreme Court decision in the Knoxville case will be, advise that the matter of compromise receive your careful consideration. However, it is my understanding that the Cameron Company refuses to make any reasonable compromise, and now demands the same royalty it demanded prior to the decision holding its patent to have expired.

On June 21st, of this year, Mr. Clarke, a member of the firm of Mundy, Evarts, Adcock & Clarke, of Chicago, which firm is now representing the Cameron Company, wrote to my partner, Mr. John H. Miller, to the effect that the Cameron Company would accept from users of the septic tank, for each year of past use, three per cent of the gross cost of the plant, and for the future use thereof during the life of the patent, five per cent of such gross cost. You will note that the Cameron Company, by demanding three per cent for each year of past use and only five per cent for the remainder of the life of the patent, is endeavoring to force users to settle now and so avoid the possibility of hereafter being compelled to pay for each year's use prior to the decision of the Supreme Court, three per cent of the gross cost of their respective tanks. Of course, such possibility could only arise in the event the Supreme Court decides the Cameron patent did not expire on November 9, 1909, but continues in force until October 3, 1916.

As a matter of business policy, you must, therefore, decide whether to accept the unreasonable terms now offered by this company or take the chance of either not paying anything at all or being compelled to pay, for each year's use prior to the Supreme Court's decision, such sum of three per cent of the cost in addition to the five per cent which will be demanded for the use of this tank for the remainder of the life of the patent, if the same is finally adjudged not to terminate until 1916.

I do not know to what extent the Cameron Company has collected royalties for the use of its septic tank and, therefore am not in a position to say whether it has an established royalty which would be accepted by a court as a measure of

damages in any suit brought for the infringement of this patent. In the absence of a measure of damages based upon an established royalty, it would be most difficult if not impossible for the Cameron Company to obtain any judgment against an infringer save for costs of the suit and nominal damages.

In the event of the Supreme Court deciding that the Cameron patent does not expire until the year 1916, the users of septic tanks may, in any suits brought against them, again contest the validity of such patent. However, in view of the Court of Appeals decision adjudging the patent valid, there would now be very little chance of proving the patent invalid unless some new defense, not made in the Saratoga case, can be found. In order to ascertain if there are any facts not proved in the Saratoga case and which would, if proved, invalidate the Cameron patent, an expensive investigation would have to be made.

If any of you gentlemen have any questions to ask in regard to this matter, I will try to answer them.

MR. KIRKBRIDE. What suits are there pending in California on this?

Mr. WHITE. There is a suit against the City of Fresno, but last Monday the trial of it was continued for the term, and there is very little possibility of that same being tried until the Knoxville case is determined by the Supreme Court.

MR. KIRKBRIDE. How about the Santa Clara suit?

MR. WHITE. I believe no answer has as yet been filed in that case. I understand the time for answering has been kept open by Mr. Clarke, the attorney of record for the defendant.

MR. BARNEY of Hanford. The City of Hanford has been notified several times, but there has been no suit filed against us.

MR. WHITE. The Cameron Company has appointed attorney agents throughout the country, and those attorneys have been endeavoring to collect what they can of the various municipalities without suit. In the east there are two or three organizations of municipalities formed for the purpose of defeating this patent, and I think if any suit is hereafter prosecuted to a final determination, it will be some suit in the east, as the attorneys for the Cameron Company reside in Chicago. I therefore believe the burden of any further litigation will naturally fall upon some eastern municipality or municipalities.

A DELEGATE. Your idea is, then, that if the Supreme Court upholds the patent, we would have to pay royalty or settle the suit in some way?

MR. WHITE. If the Supreme Court overrules this plea and holds that the patent does not expire until 1916, then of course it will be necessary for us to either defend these suits or pay the royalty which they demand.

MR. KIRKBRIDE. Are there any provisions of the patent law whereby they can renew the patent?

MR. WHITE. There is no provision whereby they can renew it or have its life extended without an act of Congress, and I think the municipalities throughout the country can very easily prevent such an act being passed.

A DELEGATE. What is the life of the patent?

MR. WHITE. Seventeen years, and it expires in 1916, if it has not already expired.

MR. KIRKBRIDE. What is your advice as to the action of a municipality about to construct a septic tank?

MR. WHITE. That is a matter of business policy to be decided by the municipality. Undoubtedly it would be taking the chance however remote, being compelled to pay the royalty demanded by the Cameron Company. In respect to



this royalty, I will read Mr. Clarke's letter of June 21st of this year, to Mr. Miller, to which I have already referred:

"It is difficult to form a definite estimate of the extent to which infringement has gone in the State of California, but the Cameron Company state that, on a conservative estimate, giving the municipalities the benefit of any uncertainty, two and a half years has been the average infringement period, reckoning the various plants in proportion to their respective costs. With this two and a half year's estimate as a basis, the company applies its established royalty rate of three per cent per annum for past infringement, which is a rate it cannot reduce, and states it would accept, in settlement of past infringement, seven and one-half per cent on the aggregate cost of installation of the plants, conditioned that all of the municipalities in or associated with the League are included in such aggregate. The plant is always considered as including the septic tank, the filter, and the aerating bed, when the tank is associated with either or both of the latter features, since the frame of the patent relates to the septic tank either alone or in combination with either or both of said features. The cost-total figures would be furnished by the League and evidenced by proper vouchers. With respect to future use and installation of plants in California, to the end of the stated term of seventeen years of the patent, the company would accept five per cent of the aggregate cost of plants already installed, and one and a half per cent per annum (but not to exceed a total of five per cent) on plants hereafter installed." In other words, for future plants, they charge five per cent of the gross cost thereof, and for plants already installed, three per cent per annum for past infringements, and for future use they charge an additional five per cent of the gross cost thereof. It may be possible, by reason of the fact that the company has already collected from a large number of municipalities this five per cent royalty that they can establish that as a measure of damages, but I doubt very much whether they can establish this other amount as a measure of damages, to wit, three per cent per annum for past infringement. I doubt if anybody has ever paid that.

MR. McCLURE. Do I understand that some municipalities have paid the damages in California?

MR. WHITE. I believe two or three claims have been compromised. Mr. Locke knows more about that matter than I do.

MR. LOCKE. I will state that when these notices were first received from the Cameron people among the various municipalities, which precipitated the meeting of these gentlemen in San Francisco, followed by a subsequent meeting in San Jose, that the City of East San Jose and also the City of Los Gatos participated in the deliberation and had their attorney there, and I believe Mountain View was there, all of which cities have settled with the Cameron Company. I think Los Gatos paid and Mountain View paid something like \$250. While I am on my feet, I might add that I understand there are quite a number of municipalities in the State contemplating the installation of septic tanks, and it is my understanding that, regardless of how this litigation may come out, it is inadvisable for them to attempt to avoid infringement. The evidence goes to show that the Cameron tank did the work perfectly, and from my investigations, I am satisfied that there is no question at all but what other tanks, constructed on the specifications laid down by Cameron, will be an absolute success. But there have been quite a number of failures, due to the fact that attempts have been made on the part of engineers to avoid infringing on the Cameron patent. It is my opinion, and I believe Mr. White will also agree with me, that it would be inadvisable on the part of any municipality contemplating the construction of a septic tank, to

attempt to avoid infringement. It would be better to build a tank that you are sure will work, even if you are required to pay the \$250 or \$300 royalty that you will be compelled to pay if the suit is decided in their favor.

MR. WIELAND. Is it not the fact that their five per cent really represents the engineering fee that they would charge in the event that they designed the plant originally?

MR. WHITE. As I understand it, they do not design the plant. They are willing to furnish you with specifications and plans. They have those plans and specifications on file in their office, and they can send them out anywhere. They do not specially design a plant suitable for a given location. In other words, they will give you the complete drawings and specifications for any certain standard proposition.

MR. WIELAND. But the question is then whether or not it would not be advisable to pay them the engineering fee at the outset, which would possibly be no more than would have to be paid to any other engineer for doing the same class of work.

MR. WHITE. I never have understood that they are willing to make any such terms. As this letter states, they charge five per cent of the gross cost for future installations—nothing is said therein about engineering fees.

MR. WIELAND. The reason I spoke of it is that it was at one time taken up—they took up a certain problem, and my impression was that their fee was a certain percentage of the total cost—no additional charge for the use per annum thereafter.

MR. WHITE. In respect to that I will state that I doubt very much whether that is the fact, and for this reason: Any such arrangement as that would prevent them from establishing a fixed royalty, and that is what they are endeavoring to do, because without a fixed royalty established, they will have no measure of damages in any suit at law or in equity.

MR. KIRKBRIDE. If it were shown that that would be the case, would that be an element of defense in an action brought for royalty?

MR. WHITE. That would be a matter of defense, for the reason that it would show that some parties did not pay five per cent for the use of the invention alone, but for the services of their engineers, and of course, that is something no municipality here has ever done—no municipality here, as I understand, has ever obtained any plans from them or any advice from their engineers. So that would be a defense to a claim that they had an established royalty of five per cent of the aggregate cost.

MR. WIELAND. I think they drew up the plans for Granada. I had a talk with their engineer several years ago, who was Mr. Fee—I don't know whether he represents them now, or not. My impression is that he told me they had designed the Granada plant.

MR. WHITE. Do you know what they charged in that case?

MR. WIELAND. No, I do not. It is on the Ocean Shore Railway near San Francisco.

MR. WHITE. You will note now that their charge is five per cent for future installations and this statement that they intend to charge three per cent per annum for past infringement is to force everyone to pay the royalty now rather than to take the chances of being compelled to pay three per cent additional after a suit is brought. But I doubt very much indeed if they will be able to prove the payment of three per cent for past infringement in such a way that it will be held good, as a measure of damages.

MR. WIELAND. As I say, my impression was that they would design a plant today for five per cent, allowing you to use it, provided your information is correct—five per cent for future installation would seem to me to imply their complete charge. That would be in seeming conflict with the statement that they would charge per annum a certain royalty for past infringement. That might be an interesting thing for you to ascertain definitely.

MR. WHITE. I will endeavor to find out.

MR. WIELAND. In other words, if today you want to have a plant installed or designed for a town of 60,000 population, giving the amount of sewage, whether they would design that, giving you the details and specifications and allowing the use thereafter for a lump sum, we will say, an engineering fee of five per cent.

MR. WHITE. I repeat, that if they do that, that would interfere with their measure of damages.

MR. LOCKE. I think I can answer that. We put that up to their attorney, Mr. Petree, in San Jose, and he wrote back to the main office in Chicago, and received a reply verifying what Mr. White states, that they would insist on the payment of the amount specified for infringement.

MR. WIELAND. Yes, but for instance, the East San Jose plant has not yet been established, has it? Has it been installed?

MR. LOCKE. I could not say. My impression is that it has not.

MR. WHITE. According to this letter, they charge three per cent a year for past infringement, and if those infringers desire to use the tank for the rest of the term of the patent, he states as follows:

"With respect to future use and installation of plants in California, to the end of the stated term of seventeen years of the patent, the company would accept five per cent of the aggregate cost of plants already installed, and one and one-half per cent per annum (but not to exceed a total of five per cent) on plants hereafter installed."

It says nothing about engineering fees in this letter.

MR. KIRKBRIDE. Mr. President, I move that the old committee be continued in effect, or that a new committee be appointed upon this subject. My town contemplates the construction of a tank, and personally I think I would be disposed to advise them to join with the League here in contesting the matter and taking our chances on the payment of damages in the future. Even if it lasts until 1916, maybe they will not be able to get any damages, even we do infringe it.

MR. LOCKE. Before that motion is put, I would like to ask Mr. White a question. He made a statement at the outset of his remarks that he had reason to believe that the decision of the Supreme Court would be favorable to the cities as against the company, and I would like to ask if he has any reason which he would care to give at this time as to why he feels that way.

MR. WHITE. My reason for making that statement is that their contention is based entirely upon one decision of the Circuit Court of Appeals, in the case of Hennebique vs. Meyers, reported in 172 Federal. But since then other courts have held to the contrary, and the weight of authority is to the contrary at the present time. In order to make their contention good, they must contend that the Treaty of Brussels, which was proclaimed in 1902, has a retroactive effect, and I don't think the Supreme Court will sustain that contention.

PRESIDENT BUTCHER. Will you state your motion again?

MR. KIRKBRIDE. It is that the present committee be continued in effect,



or a new committee be appointed. I should prefer the present committee, I think.

MR. LOCKE. I don't believe there was a committee appointed, Mr. Chairman. I think the motion had better be to appoint one. I think this matter came up since our last annual meeting, and it was taken up by the Secretary of the League and myself, in San Francisco, and a meeting called at the suggestion of Mr. Osburn. I would suggest at this time that it might not be inadvisable to appoint a committee of this body to have charge of the matters pertaining to this litigation in the name of the League.

MR. OSBURN. I think that is right, if I remember correctly. That is substantially what was done. After the meeting of the League a year ago, this septic tank matter came up in College Park, I think it was, and the Secretary, upon his attention being called to it, appointed a committee consisting of Mr. Osborn, Mr. Long of San Francisco, and Mr. Locke, and a gentleman from College Park, Mr. Wise, I think it was, and another gentleman from Mountain View, and myself. Mr. Free, the District Attorney of Santa Clara County, was also appointed—he was engaged in the College Park litigation, as that is outside of the city limits of San Jose.

PRESIDENT BUTCHER. If there was no committee appointed by this body, I will rule the motion as made by Mr. Kirkbride out of order, and the chair will entertain a motion to the effect that a committee be appointed.

MR. KIRDBRIDE. I will make that motion, and that it be a committee of five, to look after the matters pertinent to the subject-matter of the septic tank litigation, and take such action as may be necessary, and report to this body.

The motion was seconded and prevailed unanimously, and the President announced that it would appoint the committee the following morning.

Adjourned.

## OAKLAND'S HIGH PRESSURE AUXILIARY FIRE SERVICE SYSTEM

---

Some five years ago the Oakland City Council took the first steps toward acquiring an auxiliary system for fighting fires. The water supply is privately owned. There had been a lack of storage within the city limits, and the pipe system was without adequate main arteries. The business portion of the city is connected with the principle supplies by a 37½ inch pipe laid on a long wooden bridge and two 24 inch lines laid in a fill over a marsh. These lines as built add a considerable element of danger to the supply in case of an earthquake. The earthquake of 1906 interrupted the water supply for some six hours by a break at this and other points.

However nothing was actually done until after the earthquake of 1906 when the Council ordered the City Engineer to prepare plans and appropriated money to begin the work. The understanding being that the system was to be paid for from the current income of the City, extending the system from year to year as the money became available.

This was worked out by building the pumping station and machinery at a cost of \$50,000 the first year, a portion of the distributing system the following year at a cost of about \$50,000 and this year we extended the distributing system

at a cost of \$25,000 and hope to continue at this rate for the next three or four years at least.

#### SUPPLY

The public water supply being privately owned and in the condition just described it was considered not advisable to attempt to pump from that source. As there was no other supply of fresh water available it became necessary to use sea water. Oakland Harbor extends along the southern boundry of the City and within about half a mile of the business center while Lake Merritt and its entrance from the Harbor form the eastern boundry of the business district and is about the same distance from its center. This gave a good supply of salt water but an investigation of pumping station sites showed that on account of high cost of land and unsuitable foundation the supply must come from Lake Merritt.

Lake Merritt is really an artificial lake, covering 160 acres, made by building a dam across the lower end of tidal flats, the water being held at about high tide by automatic gates which allow the water to flow in at high tide but prevent its flowing out. The lake has been dredged to about 7 feet deep.

This lake gives us a never failing supply of clean salt water the surface of which is always at about the same level. The lake is nearly surrounded by park lands and as the site chosen was in this park the building was designed both as a park building and pumping station.

It is some four miles to an elevation in the hills at which the reservoir could be built making possible a gravity system. The cost of constructing and maintaining this long main was considered so high that the direct pressure system was chosen. This system demanded machinery that would be always ready to start with little loss of time in case of a fire.

#### PUMPING MACHINERY

The source of power for such a plant must meet the following requirements:

1. Reliability.
2. Capable of being started on an alarm of fire in time to be of proper use.
3. Small standly cost and deterioration loss.
4. Small cost for attendance.
5. Must not be offensive in a park.

The actual fuel economy while operating is not important as the actual operating time per year is very short.

Four sources of power were considered:

Electric motors.

Steam engines.

Gas engines running on gas from the street mains.

Gas engines running on gasoline or distillate.

The Board of Fire Underwriters protested vigorously against the use of electric motors on account of the liability of breakdown of the long transmission lines from the mountain power houses and the fire hazards at the steam power plants in the city. They also objected to gas engines running on gas from the street mains on account of the chances of lack of pressure and of failure in case of earthquake.

These two sources of power would depend on private enterprise the entire load of which would have to be supplied at very short notice. If this power was drawn from the general distribution system the supply might be weak or entirely cut off when needed. On the other hand, if the necessary machinery to furnish the power required on call had to be installed, the owners would look to the city for enough income to defray the expense of providing and maintaining it.

A steam driven plant would cost approximately the same as the gas engine installation. Although the cost of operating the steam plant would be slightly higher than the gas engines the ultimate cost was considered the same. A steam

plant would require a larger building, a tall chimney and the hauling and storage of fuel oil which would be objectionable in a park. There would also be a considerable deterioration of the boilers and auxiliary machinery, since at least one boiler would have to be kept under fire at all times, while the gas engine plant stands idle with no loss.

Gas engines operating on distillate have an independent source of power since sufficient fuel for a long run can be safely stored in a small space underground.

Gas engines were selected as it was felt that gas engines had reached such a high degree of perfection that they were as reliable a source of power as steam engines. The several large fire-fighting plants using gas engines that are in successful operation show the results obtained in service with equipment of this type.

The multi-stage turbine pump was held to be nearly ideal for the conditions involved and for the service required, owing to its simplicity and the fact that it is started by the application of power, without requiring the manipulation of by-pass or other valves. This type of pump will also handle without injury the salt water supply that is available. The pumps may be started when a call on the station is made and run at full speed without water being drawn from the hydrants, although the maximum pressure will be maintained on the system. The water then may be drawn as needed until the full capacity of the pump is reached, and the maximum pressure maintained meanwhile. In fact, with the design developed the pumps maintain the pressure on the distribution system the same as it would be kept up by an elevated tank or reservoir.

The machinery at present installed consists of two pumping units and a third one is contemplated in the near future, space being provided for it in the station. Each unit consists of a 250 \*horse power, 6 cylinders, vertical, Doak gas engine direct connected to a four stage Krogh turbine pump of a capacity of 1000 gallons of water pumped per minute against 200 pounds pressure per square inch. As the engines run at 285 revolutions per minute and the pumps at 1140 revolutions per minute some means of connection with this speed ratio was necessary. Belts or manila rope drive could not be used on account of the fire risk while the speed of it is too high to admit the use of wire rope or chain drive. The connection used consists of helical spur gears running in oil and although there was some hesitation in adopting gears on account of these gears operating contrary to the usual practice, that is to reduce the speed, they have proved remarkably efficient and quiet running.

The engines start on compressed air, the supply of which is maintained in storage tanks by duplicate sets of air compressors driven by gasoline engines.

The ignition current is from three sources, two sets of primary batteries and one set of storage batteries in addition to which current can be taken direct from the dynamo that is used to charge the storage batteries.

A standing pressure of 50 pounds is maintained on the pipe system by automatic electric pumping apparatus and fresh water is pumped into the pipes to replace the loss by leakage.

The building is a reinforced concrete building with tile roof and has toilet facilities and wide porches making it an ornamental park building as well as a pumping station.

#### DISTRIBUTION SYSTEM

The pipe system is of ordinary cast iron pipe with the usual pitch coating. In designing the system the mains were made of ample size to allow considerable incrustation without cutting the capacity below that required and the pipe was made thick enough to allow considerable corrosion without weakening it too much to withstand the pressure.

The pipe system presents no unusual features, mains being laid on alternate

---

\*Manufactured by the DOAK GAS ENGINE COMPANY, Fourth and Madison streets, Oakland, Cal.



streets and cross connected with a hydrant at each street crossing. As laid out ten streams can be concentrated on any one point with a maximum length of hose of between four and five hundred feet.

The ordinary bell and spigot joint is used of proper proportions for the pressure carried. The mains are laid about  $3\frac{1}{2}$  feet deep and are tested to 400 pounds pressure per square inch.

#### HYDRANTS

The hydrants are one of the unique features of the plant being a flush hydrant.

The hydrants are each in a concrete manhole built at one side of the main and below the surface of the street, a location being selected in each case as near the center of the street intersection as possible. This type of hydrant was chosen because any possibility of damage to a hydrant by a wagon or other vehicle striking it was eliminated. These hydrants also avoid the difficulty occasionally experienced with the usual type of post hydrant, placed behind the curb at the corners of a street intersection, being rendered unsafe for use during a fire in an adjoining building. The hydrant manholes each have a cast iron cover so that any part of the hydrant may be repaired or replaced without disturbing the surface of the street. The cover also is of such design that two men can lift it with ease.

Each hydrant has a manifold of 8-inch pipe which is connected inside of the manhole to the main. A valve on this connection is provided with a hand wheel in the manhole, placed where it can be reached and operated readily. Five 3 inch hose connections are attached to the manifold by means of flanges. Each connection is provided with a gate valve so it may be operated independently. The manifold not only permits a quite satisfactory arrangement of these connections, but also reduces the loss by friction in the hydrants to a minimum.

On each hydrant is a 4-inch connection, by means of which standpipes for buildings can be supplied through a pipe laid underground and provided at the hydrants with a gate valve. These standpipes have hose connections at the sidewalk which are left open for use with fire engines and fresh water. The connection with the high pressure system is made at the base of the standpipe, so the one above it can be left open without interference. Since the hydrants are ordinarily only 280 feet apart on the mains, it was considered better to make the standpipe connections at them, where they are readily found, rather than along the main between the hydrant.

No connections to the high pressure mains are provided for automatic sprinkler systems, since the latter are supplied to best advantage from the fresh water system of mains for several reasons. In the first place, the automatic sprinkler system is most valuable in stopping fires before much damage is done to other than the contents of the building, and fresh water causes less damage from this source than does salt water. The automatic sprinklers frequently become operative before the alarm of fire is given, in which case the salt water system would not give an effective pressure nor enough water until after the alarm had been sounded.

#### COST

The cost of the pumping machinery now installed was about	\$28,000
Building about	\$23,000
The cost of the building was somewhat higher than would be ordinarily incurred under most conditions.	
17,350 feet of mains and 50 hydrants have been installed at a total cost of about	\$75,000
The average unit costs has been as follows:	
14-inch main laid	\$4.00 per foot
12-inch main laid	\$3.25 per foot
10-inch main laid	\$2.50 per foot
Hydrant complete	\$230.00

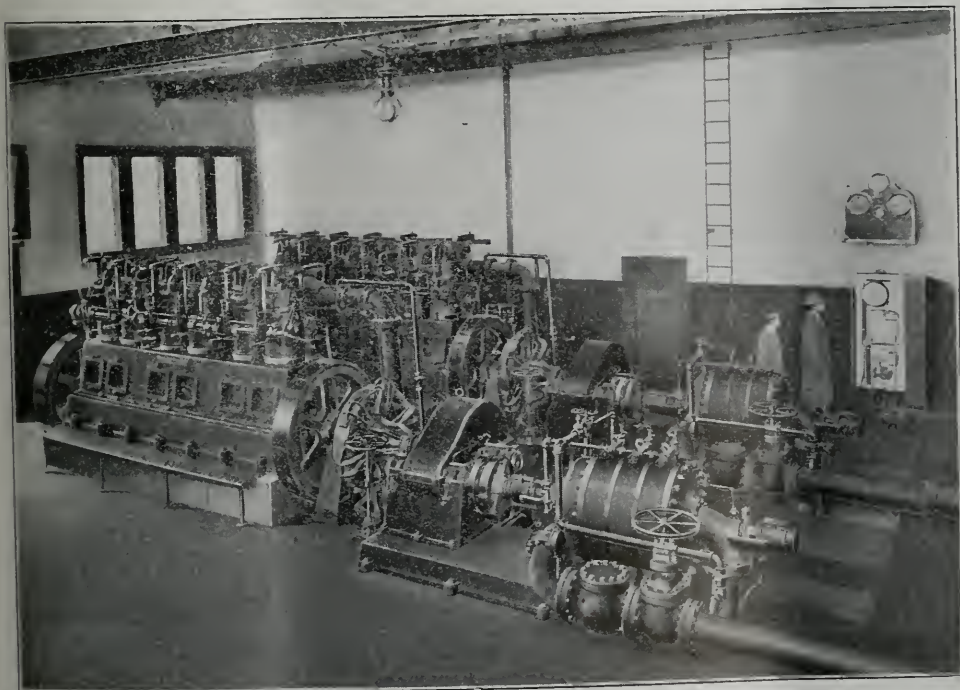

OAKLAND'S HIGH PRESSURE FIRE FIGHTING SYSTEM

These prices do not include specials or the replacing of pavements and is based on pipe at \$33 per ton at Oakland.

The average cost for the distributing system is about \$4.25 per foot complete. The system as now installed gives protection to about 114 blocks or approximately 150 acres of building area.

#### OPERATION

The pumping plant is operated by three men, one superintendent and two engineers, each man doing duty in turn but the superintendent holding himself always ready to take charge of the plant on an alarm. The pipe system is inspected regularly by a man detailed from the fire department.

On receipt of an alarm from the area protected by this system the engineer prepares to start the machinery immediately but waits for orders before doing so. On account of the damage done to merchandise by salt water the fresh water facilities are used as long as sufficient. When the high pressure is needed a signal is sent to the station or simply the opening of a hydrant gives the call as during a fire the engineer stands on the running board of one engine watching the pressure gage. A sudden drop in pressure shows him that a connection has been made to the system and he immediately starts one unit. The venturi meter gage shows the amount of water being pumped and when the capacity of one unit is approached another is started. Shutting down takes place in the reverse order. Ordinarily a unit can be put into operation in less than 30 seconds.

A fire boat connection has been installed on the water front making it possible to pump from a fire boat through the whole system, this will be used in a conflagration in which case the amount of water available would be at least double the capacity of the present machinery.

This system gives an added protection not only to the area in which it operates but to all the outside area also as when the fresh water facilities that first respond to a fire in the high pressure district are unable to extinguish it the high pressure system is put into operation instead of calling in the outside fire companies, they being left to protect their districts.

The installation of the plant of the Oakland High Pressure Fire System was done by the Doak Gas Engine Co., Oakland.



### COMMITTEE ON VROOMAN ACT

---

The committee of attorneys appointed at the San Diego convention, on revision of the Vrooman Act, was given a hearing before the legislative committees at Sacramento, on Thursday evening, February 2nd.

The committees on Municipal Corporations, of both houses, assembled in joint session in the Assembly Chamber, for the express purpose of hearing the attorneys from the League.

Strong arguments in support of the proposed amendments were made by City Attorneys Osburn, Long of Long Beach, Kirkbride, Windrem, Locke, and Assistant City Attorney O'Brien of San Francisco. Several additional changes were suggested, and the League Committee spent the entire next day in a final revision of the bill. It has since been reprinted and offered by the Assembly Committee on Municipal Corporations as committee substitute bill number 1339. The League attorneys have received assurances that the measure will probably become a law.



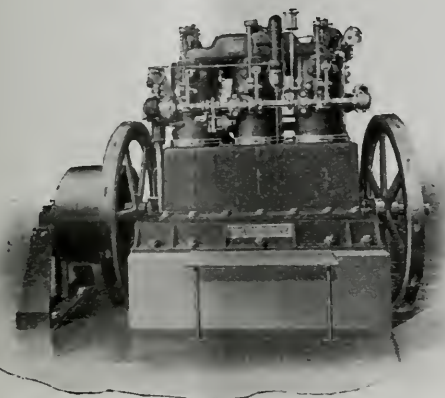

Multi-Cylinder Stationary Engine, 25 to 300 Horse-Power

See article "Oakland's High Pressure Fire Fighting System," page 29.

Any information concerning plants of this character will be gladly supplied to those interested.

## Doak Gas Engine Co.

7 First Street

SAN FRANCISCO, CAL.

The Simplicity and Reliability of

**DOAK'S  
ENGINES**

strongly recommends them for

**Fire and Domestic  
Pumping Plant Service.**

Practically all of such plants installed in California have

**DOAK  
ENGINES.**

### QUESTIONS AND ANSWERS

Q.—Dear Sirs: I am writing to ask if the League of Municipalities at their last convention took up the matter of a system of bookkeeping for the different towns, and if so if anything has been done in the matter. Our Board of Trustees of East San Jose have the matter of a better system of keeping town accounts under advisement, and we would like to know if any plans have been adopted by the association.

Ans.—The matter of uniform accounting for municipalities was taken up at our recent League meeting at San Diego, but practically little was done. An illustrated lecture on Ideal Municipal Accounting was delivered by Mr. William Dolge, an expert in this line of work; this lecture was accompanied with stereopticon views, showing the best forms for warrants, tax receipts, lists, etc.

There is now under consideration at Sacramento, however, three bills relating to this subject; one prepared by Mr. Mason, our Secretary, indorsed by the Republican State Committee; and providing for a uniform system of reporting; another, providing for a uniform system of accounting and reporting, which I think will pass; also, the Board of Control Bill, which provides for uniform accounting and reporting, but which is being met with some opposition. In all probability there will be a bill passed putting the matter under the jurisdiction of the State Controller, Mr. Nye.

I would advise you to wait until the legislature has disposed of these bills.

Q.—We are about to frame a new "Fire limit ordinance" and I will thank you to kindly send me copies of ordinances that you might have in your possession along those lines, so that we can assemble data for our proposed ordinance.

Ans.—We herewith enclose a copy of the Los Angeles Ordinance relating to fire limits. An ordinance for a small municipality is prepared on the same general plan, but unfortunately we have no copies on hand at present. We are sending you also extracts from San Francisco Ordinances which may be of some use.

Q.—Dear Sir: Will you kindly advise me whether there is any material change in the method of assessment and collection of Town Taxes (sixth class) other than that we are not to assess public service Corporations.

Can we assess and collect as usual with this exception?

Ans.—There is no change in the method of assessment and collection of Town Taxes. The constitutional amendment recently adopted exempts public service corporations from payment of municipal licenses and taxes, but this does not affect municipal taxes on the real estate.

Q.—Is it mandatory on cities of the Fifth Class to hold Primaries? Must the City Clerk give notice of Primaries, even though it is expected that all candidates will be independent?

Do you think there is any likelihood of the proposed Primary Election Law now before the Legislature, being passed early enough to affect our April elections?

Ans.—In Pacific Municipalities for January, 1910, we rendered an opinion that the new primary law was not mandatory on cities. This was made and published after conference with the Attorney General's Office, in which our views were sustained.

The provisions of Sections 3 and 4 of the primary law, providing for the publication of "Notice of Election" by the Clerk, may be regarded as directory, not mandatory. However, should some individual insist on running as a candidate under the primary law, and get out his nomination papers and file them in the time and manner provided by the law, it might be advisable to hold the primary election if you thought such individual would be liable to make trouble and carry the matter to court. That is not likely to happen however, as it is easier to get on the ballot by petition, and another thing, candidates for salaried offices, under the primary law, must put up a fee.

We have examined the proposed amendments to the election laws, and find that none of them can be passed and approved in time to affect the coming elections in cities of the fifth class to be held April 10th.

Q.—Gentlemen: The initial steps have been taken to install a sewer system in the Town of Etna; upon the completion of the survey an effort was made by direction of the Board of Trustees to secure from the property owners, whose property was traversed by one of the sewer mains, permission for rights of way. The majority gave such permission but a small minority have refused. The installation of the mains in no case causes any damage further than excavating and refilling the ditch for the mains. What course should be pursued in the matter? Also, two property owners have no access to the proposed lines of mains. Can a right of way to such mains be forced through the contiguous property upon bonds being given for any damages caused thereby?

Ans.—Dear Sir: Replying to your inquiry of February 9th, would advise that you call the small minority of objecting property owners before the board and try and convince them of the necessity of the sewer system and the power of the trustees to enforce its construction. You might read to them Section 870 of the Municipal Corporations Act, and Sections 1237 and 1238 of the Code of Civil Procedure, and remind them that if they put the town to the extra expense and necessity of compelling the trustees to take legal proceedings, they will have to pay for it themselves in the shape of higher taxes.

A better and more effective way to settle the matter may be accomplished by

the board offering to submit the matter of damages (if any) to arbitration, the property owners to select an arbitrator, the board to select the other, and both to select a third.

You cannot force a right of way through private property to a main sewer, for the benefit of two other property owners.

Q.—Gentlemen: The duties of the city clerk and city marshal in our city have increased to such an extent that the compensation paid them previously is now entirely inadequate to the time and work outlined and required of these officers. We are aware of the provision in the statute where the compensation for such officers must be established by ordinance prior to the term upon which they are serving, but write you at this time to ascertain whether any Supreme Court decision has been rendered covering this point, or whether there is any way by which the trustees may raise the salaries of these officers without a possibility of being enjoined from payment of the same?

ANS.—The only Supreme Court decisions covering this matter of salaries have construed the law strictly. Of course you understand that the Marshal may receive additional compensation as Tax Collector, provided he is given that office under Sec. 871.

Likewise the clerk may receive one salary as Clerk, and another in addition as Assessor.

Assuming that you have already done this, you may create and appoint them to other subordinate offices; for instance, you may make the Marshal, Street Superintendent also, or Health Officer, with nominal duties and a salary that will compensate him in full. The same may be done by the Clerk. This is allowed under Section 852 (see latter portion.)

Q. Enclosed find a letter received from the Cameron Septic Tank Company, which will explain itself. It is my understanding that this matter is in your hands to be settled, and if so would ask what is the status of same in regard to towns of the 6th class. It is my understanding that the town of Sebastopol is not infringing and therefore do not understand the reason of these communications, as this is the only one of many received. Would be pleased to hear from you with reference to this matter. An early reply would be appreciated.

ANS. Your communication enclosing letter from the Cameron Septic Tank Company, duly received. The question is now before the Supreme Court of the United States regarding the life of the patent. There is a question whether it expired in November, 1909 or runs until October 3, 1916.

We have heretofore requested that all communications from this company be referred to the attorneys engaged by the league, Messrs Miller and White, Crocker Building, San Francisco. Otherwise you may disregard any further communications from the Cameron Company, as no suit will be brought while the case is pending, and no additional penalties imposed for waiting until its determination. (See article published elsewhere in this issue.)

Q. My Dear Sir:—

Do you know of any municipal or state law authorizing a municipality to file a lien on property for cleaning and clearing up said property?

ANS. If the property requiring cleaning or clearing up is so bad that it is injurious to health, or indecent or offensive to the senses, so as to interfere with the comfortable enjoyment of life or property, it is a nuisance and may be so declared by the municipality.

"The lawful charge for a valid abatement of a nuisance forms a lien upon premises of equal dignity with municipal taxes, and may be enforced under general law, or in the special manner pointed out by statute."

Nickerson vs. Boston 131 Mass. 306.

Kennedy vs. Board of Health 2 Pa. St. 366.

Buffalo Union Iron Works. Buffalo 47 N. Y. 671.



Q. Gentlemen;—

Please advise in detail, the proper procedure to pursue in adopting a grade map of a city of the fifth class.

ANS. The adoption of a grade map is not a very significant proceeding, and may be done by a resolution or ordinance referring to the map so that it may be easily identified, and declaring that the figures marked thereon at the various crossings or points indicated are the figures representing the official grade at such points.

The official grade is generally established by ordinance, wherein it recites that the official curb grade at certain points therein mentioned, are at a certain elevation above a certain established base. This is sufficient for establishing the official grade in the first instance and many of the small cities and towns do not have a map made, but such a map is very convenient however. No special formality other than a resolution is necessary, for adopting the map, because if a mistake was made in any of the figures on the map, it would not affect the validity of the grade originally established by your ordinance or resolution.

Q. Gentlemen:

Will you please inform us if it is necessary for the treasurer to have permission from the board of trustees to deposit the towns funds, and in case the bank deposited in goes bankrupt is the treasurer held responsible for the amount lost; also how long does a man have to be a resident before he can be appointed treasurer?

Dear Sir:

Replying to your inquiry of January 27th, will say that a town treasurer does not have to have permission of the board of trustees to deposit funds. Section 875 of the Municipal Corporations Bill provides that the treasurer shall safely keep all money, etc. If the treasurer deposits money in a bank of good repute, and the money is lost through the bank's failure, neither the treasurer nor his bondsmen are liable. 15 South Carolina 1.

The treasurer is a custodian or bailee for hire, and is bound to exercise good faith and reasonable skill and diligence in the discharge of his duties, and, having done so, is not responsible for loss occurring without any fault on his part. City of Healdsburg vs. Mulligan 113 Cal. 206.

A man must be a resident a year before he can be appointed treasurer, or be eligible to any other elective office. Sec. 857 Municipal Corporations Bill.

Q. Is it the duty of a city attorney to prosecute cases before the city recorder for violation of city ordinances. Our city attorney claims his position to be advisory only, and that it is not his duty to prosecute his cases as above. I cannot understand why we pay a salary for a city attorney and in cases of violation of our ordinances have to employ an attorney to prosecute the cases. I have always understood that the duties of a city attorney are to the city the same as a district attorney's are to a county.

Suppose a case for violation of a city ordinance is taken before a justice of the peace, where does the fine go, to the city or county, and if the city why could not the trustees declare the appointive office of city recorder vacant and save the salary of the office for the city and have city cases tried before the justice of the peace.

ANS. According to Section 880 of the Municipal Corporations Bill, it is the duty of the Marshal to prosecute before the recorder all violations of city ordinances. You are not supposed to require an attorney in this court. In cities of the fifth class, the duties of city attorney are such as may be required by the Board of Trustees. See Sec. 789 of the Municipal Corporation's Bill. Formerly the duties of city attorneys were defined by Section 4391 of the Political Code but this was superseded by the Municipal Corporations Bill.

A Justice of the Peace of a township has no jurisdiction to try a case for violation of a city ordinance of a city of the sixth class. It must be tried before the Recorder. See Sec. 103 Code of Civil Procedure, and Sec. 882 of the Municipal Corporations Bill defining the jurisdiction of the Recorder's Court.

**BITULITHIC PAVEMENT PATENTS IN NEW YORK CITY**

FROM THE MUNICIPAL JOURNAL AND ENGINEER, DEC. 21, 1910

Warren Brothers Company vs. City of New York and Uvalde Asphalt Paving Company.—In July, 1910, a contract was made with the Uvalde Company to lay a pavement in the Borough of Richmond. Suit was commenced and a motion for preliminary injunction was made, but before the motion was argued an agreement was made between the defendants by which the contract was cancelled. The suit was therefore discontinued. The only inference, the court said, which can be drawn from this action of the defendants is that they were convinced that the specifications of the contract, if carried out would result in an infringement of the Warren patent. Within a few weeks after the first suit was settled by the cancellation of the contract a new agreement with specifications changed in certain respects was entered into and this suit was commenced to refrain the defendant from proceeding under the new specifications. The specifications in question provide that the trap rock used shall be very hard, and "it shall be the run of the crusher passing through a screen of 1-inch mesh, the sand shall be hard grained, clean and sharp and shall all pass through a 10-mesh screen."

The claims in question are Nos. 5, 6 and 11 of patent No. 727,505, granted to Frederick J. Warren, May 5, 1903, for a new and useful improvement in pavement. Referring to cases Warren vs. City of Owosso, 166 Fed. Rep. 306, and Warren Brothers vs. City of Montgomery, 172 Fed. Rep. 414, the court says that the orderly administration of Justice requires that the Circuit Courts should follow the decisions of the Circuit Court of Appeals of other circuits than their own rendered upon facts substantially identical. Of course, in such circumstances the defendant in patent causes may introduce new evidence of anticipation and may show that the facts upon which infringements are based are essentially different from those in the adjudicated case. The court therefore assumes the validity of the patent and that it was not anticipated by any of the alleged prior uses proved in the Owosso case. This leaves only to be considered the Washington, Chicago and Cincinnati prior uses and the question of infringement. The Court says that it has examined the affidavits and specimens taken by both sides from the Washington pavements and is confident that the testimony does not establish anticipation beyond a reasonable doubt.

Some of the specimens produced by the defendants have a general resemblance to the patented composition. Others taken by the complainant from the same locality have no resemblance to the particular features upon which patentability rests. The fact that the samples furnished differ so materially in structure and appearance seems to indicate that the influence of heat and cold and the use of the streets for heavy traffic during long periods of time have worked changes in these pavements so that the present structure is not what it was when originally laid.

The claims in issue are for a product, not in process. The claims must be read in the light of the description, but it cannot be doubted that any one using a Warren pavement will infringe, no matter how the pavement is produced. For instance, the specification says it is desirable to have the mineral aggregate rich in particles of the size passing the 200, 100 and 80-mesh sieve. But if the mineral particles are of the indicated size it is immaterial whether they have passed through a sieve or not. The principal question is whether stone treated as described in the specifications will produce the Warren structure. That is, whether the patented pavement can be produced by the ordinary crusher run. The defendants should show the court the pavement which they propose to lay. The complainant has produced exhibits in which the crusher run was used which seemed to conform to the structure of the patent. The conclusion is that the motion should be granted on a day to be named in the order unless in the meantime the defendants produced a sample of the proposed pavement with proof briefly stating how it was constructed. The most satisfactory method of securing this proof would be to permit a small section of the pavement to be laid with a representative of the complainant present at the time.

## EDITORIAL

### THE CAMERON COMPANY WRITES LETTERS

A number of towns have received letters from the Cameron Company recently, urging a settlement of their claims for royalty.

It is not necessary or advisable to pay any attention to these communications further than to refer the writer to Miller and White, Crocker Building, San Francisco, who are attorneys for the League in this litigation. The matter is now on the calendar of the Supreme Court of the United States and will not be taken up until 1912, in view of which, no other court will consider the matter.

Particular attention is called to Mr. White's address on this question, published elsewhere in this issue.



### W. F. MCCLURE FOR STATE EN- GINEER

We are informed that Mr. W. F. McClure, formerly City Engineer of Berkeley, and at the present time, Commissioner of Public Works of that city, has been put forward by his friends as a candidate for State Engineer. Mr. McClure is regarded as an engineer of exceptional ability and a man of broad judgment. His experience has not been limited to the northern part of the state, as he was formerly located in Southern California, where he has a host of friends and enthusiastic supporters.

The progress that has been made in the construction of good roads and streets, during the past few years, has

been in a large measure due to our capable city engineers. The engineer of one of our growing municipalities is bound to have lots of experience, and obtain a great deal of knowledge as to the merits of various kinds of pavement. For that reason we believe the best interests of our state would be subserved by the appointment of a state engineer from the ranks of those who have had this experience, and who are familiar with the local conditions prevalent in California.



### "PETROLITHIC" NOT "BITULITHIC"

League of California Municipalities,  
Pacific Building, San Francisco, Cal.  
Dear Sirs: On page 263 of your issue of January 31st, I notice that in quoting my remarks before the convention in San Diego, you use the following sentence: "We have recently paved with *Bitulithic* pavement all the streets of our city." The above quotation is incorrect inasmuch as I used the word *Petrolithic* and not *Bitulithic*, and it should be corrected in order to do full justice to the Petrolithic process under which we paved over eleven miles of streets, securing at low cost beautiful and substantial thoroughfares in every part of the city. Yours very truly,

F. P. SHAW.



### TRADE NOTES

The Knox Automobile Company has added to its extensive line of motor driven fire apparatus a triple combination pump, hose wagon and chemical engine. A picture of this complete "fire department on four wheels" is shown elsewhere in this number. They are represented on the coast by the Reliance Automobile Co., 342-352 Van Ness Ave., San Francisco.



## What the Cities are Doing

**Arcata** is considering improvements in its sewer system.

**Palo Alto** is thinking of purchasing a suction sweeper.

**Mayfield** citizens are talking of consolidating with Palo Alto.

**Chino** is considering the construction of a municipal water system.

**Lakeport** is about to commence some permanent street improvements.

**Redlands** has voted \$80,000 for two parks, one to be used as a playground.

**Vallejo** will open bids on March 10 for furnishing the city with 1200 water meters.

**Porterville** is about to commence proceedings for the annexation of new territory.

**Orland** is preparing to have a bond issue for construction of waterworks and sewers.

**Tracy** is about to install a sewer system. Engineers Sloan & Robson are preparing the plans.

**Monterey** expects an appropriation of \$200,000 from the present legislature for harbor improvements.

**Oroville** trustees have decided to ascertain the cost of experting the books of the city since its incorporation.

**Grass Valley** citizens are agitating the purchase of an automobile chemical engine to cost between three and four thousand dollars.

**Willows** Postoffice annual receipts have increased from \$6000 to \$10,000, and arrangements are being made for free delivery of mail.

**Fowler** will shortly commence proceedings for a bond issue for sewers. Sloan & Robson, the popular engineers on sewer work, are getting out the plans.

**St. Helena** is about to commence some permanent street improvements. Asphalt macadam or bituminous concrete has been adopted for the main streets.

**Chico** trustees have been informed that a sum approximately \$300 will shortly be paid into the public treasury, by the Pacific Gas and Electric Company, being two per cent of the gross earnings of the company last year, for its franchise rights.

**Chico** trustees have appointed trustee Eames to secure an expert accountant to inspect the books of the city officials. It is proposed to have such inspection annually.

**Richmond.** The city council has adopted a resolution providing for an appropriation of \$1000, with which to start on plans for an industrial exhibition at the World's Fair in 1915.

**Santa Ana,** by a majority of almost six to one, votes \$20,000 for improvements to its water system in the shape of an additional reservoir, pipe line extensions and another well.

**San Diego,** by a vote of three to one, decides to limit the life of all municipal franchises hereafter to fifty years. This action was taken in the nature of an amendment to the city charter.

**Alameda's** Park and Playground Commission has decided to engage the services of a teacher of physical training, who will supervise the play of the children, both at school and on the playgrounds.

**Nevada City** trustees have been offered the gift of a site of a municipal lighting plant, from one of the public spirited citizens of that municipality. The city is increasing its fire fighting equipment.

**Petaluma** citizens have approved their proposed new charter by a vote in the ratio of 15 to 1. The charter provides for a mayor, six councilmen, and a park commissioner, and contains the initiative, referendum and recall.

**Concord** has commenced proceedings for a bond issue for sewers. The proceedings will be conducted and the bonds sold through Attorneys Mason and Locke, while the plans and specifications are being prepared by the engineering firm of Sloan & Robson, the well known specialists in sewer construction.

**Chico** has let a contract for building a new high school to replace the one recently lost by fire. The town has purchased a \$5000 automobile combination chemical engine and hose cart which, with their new steam fire engine, will make Chico's fire fighting equipment on a par with any other town of equal size in the state.

**San Mateo, Burlingame, and Hillsborough** held a joint public meeting on the evening of February 18th, at which a lecture was delivered on the mosquito evil, illustrated with stereopticon views. The lecture was conducted under the auspices of the State Board of Health and the League of California Municipalities, and was presided over by Secretary H. A. Mason of the League.

## LIST OF RESPONSIBLE FIRMS TO BE CALLED ON TO BID FOR PUBLIC WORK OR SUPPLIES

### WRITE FOR CATALOGS

This list is arranged as a guide for the accommodation of city officials where advertising for bids is not necessary.

#### Accountant

William Dolge, C. P. A., 255 California St., S. F.

#### Architects

W. H. Weeks, 251 Kearney St., S. F.

#### Asphalt Machinery

J. I. Case Thresh'g Mch Co. 616 Myrtle St. O'kl'nd  
A. L. Young M'chy Co. 26-28 Fremont St., S. F.

#### Arch. Terra Cotta

Gladding, McBean & Co., Crocker Bldg, S. F.  
Steiger Terra Cotta & Pottery Wks, 729 Mills  
Bldg., S. F.

#### Automobile Public Service Wagons

The Thomas B. Jeffery Co., 117-125 Valencia  
St., S. F.  
Reliance Auto. Co., 342 Van Ness Ave., S. F.

#### Bitulithic Pavement

Warren Brothers Company, Los Angeles, Cal.

#### Blue Prints

So. Cal. Blue Print & Supply Co., 800 L. A.  
Trust Bldg., Los Angeles.

#### Bridge Builders

E. T. Thurston, Jr., Wells, Fargo Bldg., S. F.

#### Concrete Construction

Esterly Con. Co., Inc., 717 Market St., S. F.  
Hazelwood, Jones, Doane & Hanscom, 675  
Monadnock Building, S. F.

#### Contractors and Builders

Finch Jail Building and Metal Co., 16 Cali-  
fornia St., S. F.

#### Constructing Engineers

Fred'k C. Roberts & Co., 221 Sheldon Bldg, S. F.

#### Consulting Engineers

Sloan & Robson, Nevada Bank Bldg., S. F.  
E. T. Thurston, Jr., Wells Fargo Bldg., S. F.

#### Culverts

Cal. Corrugated Culvert Co., Los Angeles and  
W. Berkeley

#### Dump Carts and Wagons

J. I. Case Thresh'g Mch Co. 616 Myrtle St. O'kl'nd  
A. L. Young M'chy Co., 26-28 Fremont St., S. F.  
Watson Wagon Co., Canastota, N. Y.

#### Electrical Plants & Machinery

A. L. Young M'chy Co., Fremont St., S. F.  
Chas. L. Kiewert Co., 195 Fremont St., S. F.

#### Engravers and Bond Printers

A. Carlisle & Co., 251 Bush St., S. F.  
Schmidt Lith. Co., Second & Bryant Sts., S. F.  
Sierra Art Eng. Co., Front & Com. Sts., S. F.

#### Fire Engines

Gorham Eng & Fire App Co., 48 Fremont St.  
S. F.

#### Fire Hose

Gorham Eng & Fire App Co., 48 Fremont St.  
S. F.  
New York Belting & Packing Co., 129-131  
First St., S. F.

#### Lithographers

Schmidt Lith. Co., Second & Bryant St., S. F.

#### Metal Furniture

Finch Jail Bldg. & Metal Co., 16 Cal. St., S. F.

#### Municipal Accountant

William Dolge, C. P. A., 255 California St., S. F.

#### Municipal Printers

A. Carlisle & Co., 251-253 Bush St., S. F.

#### Municipal Engineers

Fredk. C. Roberts & Co., 461 Market St., S. F.  
Sloan & Robson, Nevada Bank Bldg, S. F.

#### Pavement Materials

Barber Asphalt Paving Co., S. F. and L. A.  
Warren Brothers Company, Los Angeles, Cal.

#### Playground Apparatus

A. L. Young Machinery Co., S. F.

#### Riggers

C. A. Blume Con. Co., 185 Stevenson St., S. F.

#### Road Machinery

J. I. Case Threshing Mch. Co., 616 Myrtle  
St., Oakland, Cal.  
The Good Roads Mach'y Co., Ft. Wayne, Ind.  
Henshaw, Bulkeley & Co., Fremont St., S. F.  
A. L. Young M'chy Co., Fremont St., S. F.  
Petro lithic Co., 345 P. E. Bldg., L. A.

#### Sanitary Wiping Rags

The Raychester Co., 1448 Folsom St., S. F.

#### Safes

Victor Safe & Lock Co., 1292-4 Market St. S. F.

#### Scrapers

J. I. Case Thresh'g Mch Co. 616 Myrtle St. O'kl'nd  
A. L. Young M'chy Co., Fremont St., S. F.  
Petro lithic Co., 345 P. E. Bldg., L. A.

#### Sewer (Concrete)

Esterly Con. Co., Inc., 717 Market St., S. F.

#### Sewer Pipe and Terra Cotta

Gladding, McBean & Co., Crocker B'ldg, S. F.  
Steiger Terra Cotta Co., Mills B'ldg., S. F.

#### Sidewalks (Cement)

Esterly Con. Co., Inc., 717 Market St., S. F.  
Steel Protected Concrete Co., Phila., Pa.

#### Street Signs

A. L. Young Mch. Co., S. F.

#### Street Sweepers

A. L. Young M'chy Co., Fremont St., S. F.

#### Structural Steel Erectors

C. A. Blume Con. Co., 185 Stevenson St., S. F.

#### Vaults

Victor Safe & Lock Co., 1292-4 Market St., S. F.

# SPECIFY American Ingot Iron Corrugated Culverts

This Brand  
Stands for



Durability  
Economy  
Strength

Make your culvert work monumental by insisting on American Ingot Iron, the purest iron manufactured. American Ingot Iron is 99.94% Pure and offers the greatest resistance to corrosion

**California Corrugated Culvert Company**  
Los Angeles, Cal. West Berkeley, Cal.

## Wainwright Galvanized Steel Corner Bar

For Protecting Edges of Concrete Curbs, Steps, Columns, Etc.

The only effective **Concrete Edge Protector** offered to the contracting public

WAINWRIGHT PATENTS—March 9, 1897. November 22, 1898. May 5, 1903. March 26, 1907. August 29, 1907. August 2, 1910.

This bar has been in public use for more than ten years as the main feature of the

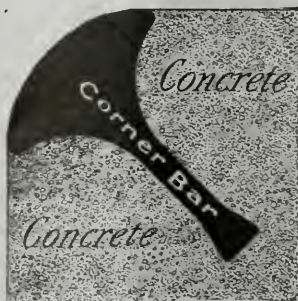

### WAINWRIGHT STEEL-BOUND CONCRETE CURB

THE BEST IN THE WORLD

OVER THREE MILLION FEET

In use in more than three hundred cities in the United States

Absolutely Non-Breakable  
Cheaper Than Granite

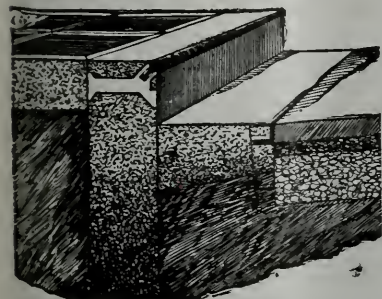

Handsome than Granite and much stronger.  
Continuous in Construction, hence Never Out of Line.  
GALVANIZED STEEL CORNER BAR Prevents Chipping or Breaking on Edges.

This Curb is Mechanically Perfect and Unequaled for Curved Corners.

THIS CURB WILL STAND HARDER USE AND LAST TEN TIMES AS LONG AS PLAIN CONCRETE CURBING.

Contractors can make money by laying this curb.

City Engineers can save money by specifying it.

Architects are invited to read pages 242 and 243 "Sweet's Index."

Metal Parts for Sale. Send for Copyrighted Booklet No. 19.

STEEL PROTECTED CONCRETE CO.

REAL ESTATE TRUST BUILDING  
PHILADELPHIA, PA.



## FINCH JAIL BUILDING AND METAL CO.

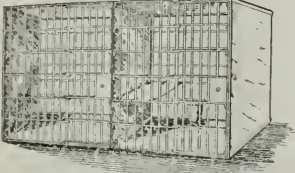

Manufacturers and Builders of

**PRISON CELLS AND ALL APPUR-  
TENANCES.**

Dealers in Metal Furniture and Fixtures

Office No. 16 California St.

Telephone Kearney 935



### BUILDING GOOD ROADS

is work that counts. To do this work economically you need a **Fort Wayne Mounted Rock Crusher** with Elevator, Screen and Portable Bin.

**Efficient, Serviceable and Convenient**

Built in several sizes

Send for catalog of Crushers, Dump Wagons, Road Graders, Steam Rollers, Sprinklers, Sweepers—Everything for Building Roads and Streets.

**The GOOD ROADS MACHINERY COMPANY, Fort Wayne, Ind.**  
Coast Representative, A. L. Young Machinery Co., San Francisco, Cal.

## A. CARLISLE & CO.

### Stationers, Printers and Bookbinders

We specialize in Bonds, Steel Die, Lithographed or Printed, for Municipalities or Counties, and the Books and Forms required by all Municipal Officers.

**251-253 Bush Street**

**San Francisco, Cal.**

W. J. LOCKE

H. A. MASON

## Mason & Locke

ATTORNEYS AND COUNSELORS AT LAW

*Bond proceedings conducted---validity and sale guaranteed*

Ninth Floor Pacific Building

SAN FRANCISCO

Members of the League can materially assist the upbuilding of our organ, Pacific Municipalities, by favoring our Advertisers wherever possible. They are always pleased to answer inquiries.

Mention Pacific Municipalities when writing to them.

# Henshaw, Bulkley & Co.

## ROAD MACHINERY

### A SPECIALTY

19-21 Fremont Street  
San Francisco

262-264 So. Los Angeles St.  
Los Angeles

TERRA COTTA, PRESSED BRICK, PIPE,  
FIRE PROOFING, ROOFING TILE,  
FLUE LININGS, FIRE TILE,  
LAUNDRY TRAYS,  
ETC.

**GLADDING, McBEAN & CO.**

WORKS  
LINCOLN, CAL.

--- OFFICE ---

311-317 CROCKER BLDG., SAN FRANCISCO.

# Steiger Terra Cotta and Pottery Works

MAIN OFFICE AND YARDS:

City Yard, 18th and Division Streets

Main Office: 729 Mills Building

Phone Douglas 3010

SAN FRANCISCO, CAL.

Factory, South San Francisco  
San Mateo County

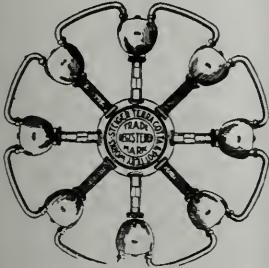

MAPS  
BONDS

STATIONERY

BOOKLETS

POSTERS

LABELS

CARTONS

ETC.

MAIN OFFICE  
SAN FRANCISCO.

PORTLAND

LOS ANGELES

**SCHMIDT LITHOGRAPH  
COMPANY**



Fire Apparatus  
Police Patrols  
Ambulances

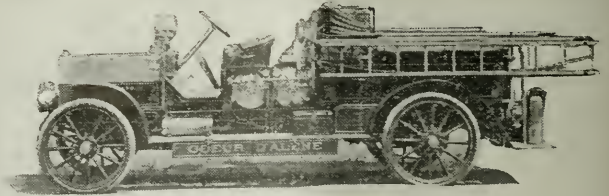

REPRESENTED BY

**RELIANCE AUTOMOBILE CO.**

342-352 Van Ness Ave.

SAN FRANCISCO

F. W. Haselwood, Assoc. M. Am. Soc. C. E.

Sidney Jones

E. W. Doane

W. A. Hanscom

**Haselwood, Jones, Doane & Hanscom**

*Civil, Hydraulic and Sanitary Engineers*

Sewers, Waterworks, Light Plants, Street Work and Bridges

Phone Sutter 1337

675-677 Monadnock Building

SAN FRANCISCO, CAL.

**E. T. THURSTON, Jr.**

Assoc. M. Am. Soc. C. E.

**Consulting Engineer**

713 Mechanics' Institute

Phones Sutter 1683 and C 2895

SAN FRANCISCO

**Specialties**

Design and Supervision of Buildings, Bridges,  
Railways, Water Works and Municipal Work

**Concrete Bridges**

Exclusive rights under patents of National  
Bridge Company, the largest in the world.

Estimates furnished free of charge.

**C. A. BLUME CONSTRUCTION CO.**

Members of Builders Exchange

**Structural Steel Erectors**

**Riggers**

Phone Douglas 324

185 STEVENSON STREET

SAN FRANCISCO

**ESTERLY CONSTRUCTION CO., Inc.**

**CONCRETE CONTRACTORS**

Buildings, Bridges, Sidewalks, Walls, Floors, Foundations

Room 605, 717 Market St., San Francisco

2136 Center St., Berkeley



SIERRA BLDG. SAN FRANCISCO





**This Page is  
RESERVED FOR**

**The Barber Asphalt Paving Co.**



**Philadelphia**

**New York**

**San Francisco**

**Chicago**

**Los Angeles and Other Principal Cities**



**WILLIAM DOLGE***Certified Public Accountant --:-- Municipal Accountant*

TELEPHONE DOUGLAS 5173

255 California Street

San Francisco, Cal.

**WM. H. WEEKS, Architect**PUBLIC BUILDINGS A SPECIALTY

251 Kearney Street

San Francisco

**SLOAN & ROBSON, Engineers**Reports, Designs, Estimates and Supervision of Municipal  
Light, Water and Sewer Systems

Telephone Kearney 4646

Nevada Bank Building, SAN FRANCISCO

**Gorham Engineering & Fire Apparatus  
Company***Fire Department Supplies of Every Description*

48 Fremont Street

San Francisco, Cal.

Branch Stores, Los Angeles, Cal.; Seattle, Wash.

**THE CLARA BARTON****Sanitary Wiping Rags**

The Clara Barton Brand of Wiping Rags  
are Guaranteed to be thoroughly sterilized  
and disinfected. Telephone Market 2286

**The Raychester Co., Inc.**

1448-1460 FOLSOM ST., SAN FRANCISCO



THE ARLINGTON

# SANTA BARBARA, THE MISSION CITY BY THE SEA.

*One Wonder*

On the  
ROAD OF A THOUSAND WONDERS

A trip to California is incomplete unless you visit this historical city with its wonderful effects of mountain and sea, its beautiful homes, its wonder garden of flowers and trees, its palatial hotels and the Always Interesting OLD MISSION.

## SOUTHERN PACIFIC

San Francisco Offices:—

Flood Building.  
Palace Hotel.  
Market Street Ferry Building.  
Third and Townsend Street Depot.

Los Angeles Offices:—

600 South Spring Street.  
Arcade Station.



# MUNICIPAL AND CONTRACTORS' MACHINERY

...FOR...

## GOOD ROADS AND STREETS

Street Signs  
National Road Machines  
Fort Wayne Road Machines  
Indiana Road Machines  
National Elevating Graders  
Elevators—Portable Bunkers  
Shares or Cutting Edges for all types of Road Machines  
Rock Crushers, Jaw and Gyratory Type, mounted and unmounted



Screens  
Steam Road Rollers  
Horse Rollers  
Scarifiers  
Harrows for oiled roads  
Wheeled and Drag Scrapers  
Fresno Scrapers  
Reversible Road Plows  
Street Sprinklers  
Sprinkling Attachments  
Street Sweepers  
Fibre for Street Sweepers  
Watson Dump Wagons  
Asphalt Machinery  
Kettles—Hand Rollers—Tampers  
Concrete Mixers  
Hoisting Engines  
Playground Apparatus  
Culvert Pipe

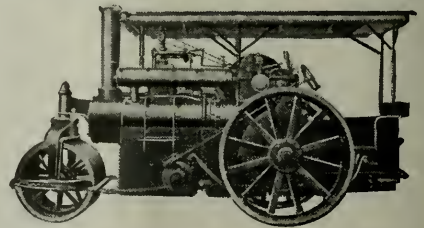

Write us for Catalogues and Estimates

## A. L. Young Machinery Co.

26-28 Fremont Street

San Francisco

California

# PACIFIC MUNICIPALITIES

THE CITY BEAUTIFUL



PUBLIC  
SAFETY  
HEALTH  
CONVENIENCE

PUBLIC  
UTILITIES  
EDUCATION  
RECREATION

PUBLISHED MONTHLY

SIERRA S.F.





When a man feels the necessity of being in two places at the same time he goes to the nearest telephone and sends his voice. It is not exactly the same thing, but when a man talks hundreds of miles in opposite directions from the same Bell Telephone, it is about as good. In the daily use of the telephone a man travels all over town by wire in a few minutes. It is just as easy to travel all over the state and other states by means of the universal Long Distance Service of the Bell System.



**The Pacific Telephone & Tel. Co.**

*Every Bell Telephone is the Center of the System*



SILENT

LUXURIOUS

3 MODELS

THE NEW  
**Rambler**

Touring Cars, Motor Fire Trucks, Chemical, Hose, Police Patrol and Ambulances a Specialty.

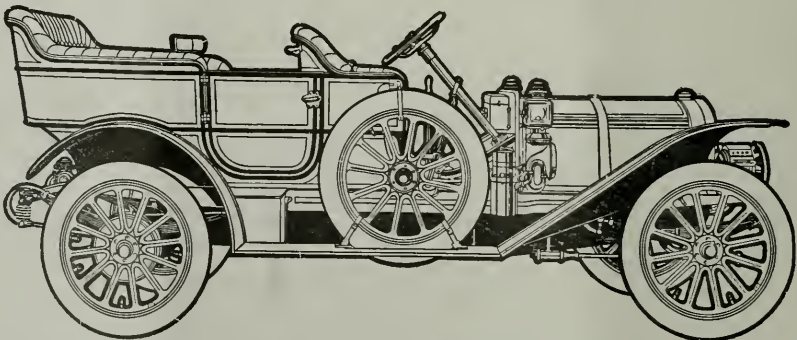

**The Thomas B. Jeffery Co.**

117-125 Valencia St.

WRITE FOR INFORMATION.

San Francisco



# “THE ROAD IS THE THING”

When built by the CASE Power-steered Road Roller

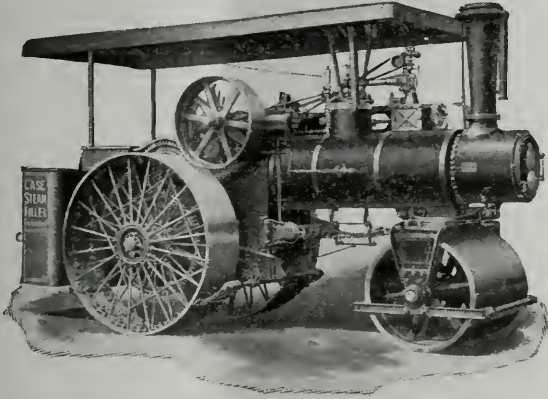

Power steering saves time over hand steering. Time saved is profit. The time saved in using a Case Roller and the extra work accomplished give increased profits to you, Mr. Contractor.

Write for Catalog on Road Roller, Road Machinery and Troy Dump Wagons and Boxes; for Contractors' General Purpose Engine and Municipal Catalog M. Address Road Machinery Dept.

Price, Simple Cylinder, \$2,200

6% discount for cash

**J. I. CASE THRESHING MACHINE COMPANY, Inc.** RACINE, WIS., U. S. A.

BRANCH OFFICE, 616 MYRTLE ST., OAKLAND, CAL.

Let us tell you about the new

**Petrolithic Gang Road Rooter and Scarifier**

**THE PETROLITHIC CO.**

345 P. E. Bldg.  
Los Angeles

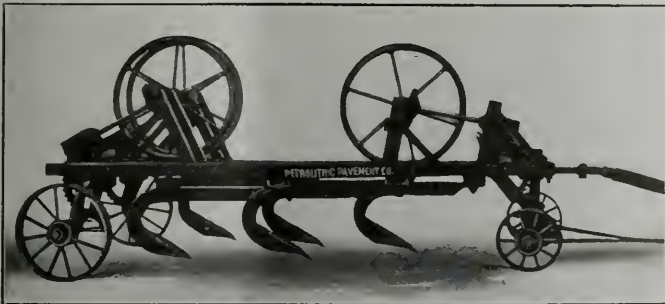

Wherever good Contractors are,

there the Watson dump wagon is known. It's the most used dumping wagon in America, both by contractors and municipalities.



Only one single type of wagon is made in our big factory. All our time and money is devoted to doing one thing, and doing it well. Our printed matter is as high grade as the wagon. Ask for it.

**WATSON WAGON COMPANY, Canastota, New York**

The First Builders of Bottom Dumping Wagons

California Agencies: San Francisco, A. L. Young Machinery Co. 26-28 Fremont St.; Los Angeles, L. M. Davenport Co.

# “BITULITHIC”

## The Ideal Boulevard Pavement

### “BEST BY EVERY TEST”

☐ BITULITHIC has been adopted as the standard pavement in more than 200 cities, all of which give unqualified praise for BITULITHIC in the earliest as well as the latest cities. More than 15,000,000 square yards BITULITHIC PAVEMENT laid and contracted for in ten years, equal to over 850 miles of 30 foot roadway, shows the rapid increase of yardage and success of the BITULITHIC PAVEMENT.

☐ The following is one of many endorsements that shows that BITULITHIC is the most essential factor in real estate development:

315-316 Dickson Building,  
Norfolk, Virginia, May 7, 1910

Mr. George O. Tenney, Pres.,  
Atlantic Bitulithic Co., Richmond, Va.

Dear Sir:—

As per your request we are offering our opinion of the Bitulithic Pavement and its influence on the value of real estate.

We believe, from comparison with various kinds of paving, that it is the most durable and satisfactory, when constructed in a high grade manner. The Seventh Ward of our city has recently completed eleven miles of Bitulithic; a large expenditure, but justified by the increased tax return from the real estate. Real estate in this ward has increased twenty-five per cent. in value.

Very truly yours,

COLLINS & VAN DENBERGH, INC.

(Signed) Paul T. Collins, President.

☐ BITULITHIC affords a superior foothold for horses in either wet or dry weather and is a sanitary, non-skidding resilient street pavement.

☐ BITULITHIC beautifies the city and enhances the value of property more than any other form of pavement.

=====*Write today for explanatory booklets to*=====

## WARREN BROTHERS COMPANY

59 Temple Place, Boston, Mass. 616 Laughlin Bldg., Los Angeles

—(REGISTERED IN THE U. S. PATENT OFFICE)—

“Bitulithic” “Warrenite” “Bitustone” “Bitrock” “Puritan” “Rockphalt”  
“Bituminous Macadam”

NOTE—Every city official in California reads Pacific Municipalities.

# Pacific Municipalities

OFFICIAL ORGAN OF THE LEAGUE OF CALIFORNIA MUNICIPALITIES

Entered at Post Office, Santa Clara, Cal., as Second-Class Matter

VOL. XXIV

TWELFTH YEAR

No. 2

EDITORS - - - H. A. MASON AND WM. J. LOCKE  
EDITORIAL OFFICE - NINTH FLOOR, PACIFIC BLD'G, SAN FRANCISCO  
PUBLICATION OFFICE, - - - SANTA CLARA, CALIFORNIA

## CONTENTS FOR MARCH, 1911

The Municipal Congress and Exposition at Chicago	53
The Program for 1915	53
A Model Town at the Fair	54
An Up-to-Date Bridge	55
Culvert Construction	56
Assessors' Duties with Model Forms, Records and Maps	59
Proceedings of the Thirteenth Annual Convention of the League of California Municipalities	63
Ideal Municipal Accounting	63
The Question of Sewage Disposal	67
Questions and Answers	71
Lecture on the Mosquito Pest in San Mateo	73
What the Cities are Doing	74
Trade Notes	74

Published Monthly. Yearly Subscription, \$2.00 in Advance. Single Copies, 25 Cents

ADVERTISING RATES ON APPLICATION

Address all Communications to "PACIFIC MUNICIPALITIES" Pacific Building  
San Francisco, California



# LEAGUE OF CALIFORNIA MUNICIPALITIES

Organized 1897

## — OFFICERS —

President	(Mayor of Berkeley)	BEVERLY L. HODGHEAD
First Vice-President	(Councilman of San Diego)	A. E. DODSON
Second Vice-President	(Mayor of Santa Cruz)	T. W. DRULLARD
Secretary	H. A. MASON	Ass't Secretary WM. J. LOCKE

## STANDING COMMITTEES

EXECUTIVE—Beverly L. Hodghead; H. A. Mason; S. C. Evans, Mayor of Riverside; Percy V. Long, City Attorney San Francisco; W. P. Butcher, City Attorney Santa Barbara.

LEGISLATIVE—W. F. Hyde, Palo Alto; J. O. Walsh, San Francisco; J. H. Strait, Redlands; F. H. Allbright, Red Bluff; B. L. Barney, Hanford.

JUDICIARY—C. N. Kirkbride, San Mateo; P. G. Sheehy, Watsonville; Stephen G. Long, Long Beach; R. E. Rhodes, Madera; Wm. J. Carr, Pasadena.

ENGINEERING—Chris. P. Jensen, Fresno; C. H. Pieper, San Jose; A. P. Noyes, Vallejo; R. C. Tumelty, Stockton; O. E. Stewart, Anaheim.

Secretary's Office and Headquarters of the League, - Pacific Building, San Francisco

## INFORMATION BUREAU

The League of California Municipalities maintains, in connection with the Secretary's Office an Information Bureau where the officials of the municipalities belonging to the League can secure information on all subjects relating to municipal affairs.

## MEMBERSHIP

Alameda	Lakeport	Riverside
Albany	Lemoore	Sacramento
Alhambra	Lindsay	San Bernardino
Anaheim	Livermore	San Buenaventura
Antioch	Lodi	San Diego
Azusa	Lompoc	San Francisco
Bakersfield	Long Beach	San Jose
Benicia	Los Banos	San Leandro
Berkeley	Los Gatos	San Luis Obispo
Biggs	Loyalton	San Mateo
Bishop	Madera	Santa Ana
Black Diamond	Martinez	Santa Barbara
Burlingame	Merced	Santa Clara
Calistoga	Mill Valley	Santa Cruz
Chico	Modesto	Santa Maria
Coalinga	Monterey	Santa Monica
Colton	Mountain View	Santa Paula
Colusa	Napa	Santa Rosa
Compton	National City	Sebastopol
Coronado	Newman	Selma
Corona	Newport Beach	Sierra Madre
Covina	Oakland	Sisson
Crescent City	Oceanside	Sonoma
East San Jose	Orange	Sonora
Elsinore	Oroville	South Pasadena
Emeryville	Oxnard	South San Francisco
Escondido	Pacific Grove	St. Helena
Etna	Palo Alto	Stockton
Eureka	Pasadena	Suisun City
Fairfield	Petaluma	Susanville
Ferndale	Piedmont	Tehachapi
Fort Jones	Pinole	Tracy
Fowler	Placerville	Tulare
Fresno	Pleasanton	Vacaville
Gilroy	Point Arena	Vallejo
Glendale	Pomona	Visalia
Hanford	Red Bluff	Watsonville
Hayward	Redding	Whittier
Hercules	Redlands	Willits
Hermosa Beach	Redondo Beach	Winters
Hillsborough	Redwood City	Woodland
Huntington Park	Richmond	Yreka
Imperial	Rio Vista	
Jackson		

Every city belonging to the League of California Municipalities is entitled to a free copy of this magazine every month for each of its officials; if not received kindly notify the Secretary. See that your City is in the above list.

WAR TRADING  
BUREAU

# PACIFIC MUNICIPALITIES

A Journal for Progressive Cities

VOL. XXIV

MARCH 31, 1911

No. 2

## THE MUNICIPAL CONGRESS AND EXPOSITION AT CHICAGO

The plan set forth in the February issue for participation in the International Municipal Congress and Exposition to be held in Chicago next September, has been indorsed by the members of the executive committee of the League. It has also received the written indorsement of Mayor McCarthy, of San Francisco, and the Board of Supervisors of said city. Appropriate resolutions were passed by the last named body indorsing the proposed plan and also the proposition to hold an international congress and exposition at San Francisco, during the World's Fair, under the auspices of the League of California Municipalities. Subsequently, similar resolutions were passed by the San Francisco Chamber of Commerce, and the San Francisco Convention League, which latter body represents the Merchant's Association and other civic organizations. Elaborate covers for the illustrated booklets are in preparation and the leading cities will be called upon in the near future and asked to participate in this feature. Those municipal officials who desire to advertise their city at the Chicago Exposition will facilitate matters by informing the League Headquarters as soon as possible.

In view of the fact that we propose to extend a formal invitation to the delegates assembled at Chicago to attend the next Municipal Congress and Exposition at San Francisco in 1915, it is most desirable that we make an impressive showing there. It is expected that a great many municipal officials will be in attendance from all over the world.

### THE PROGRAM FOR 1915

A number of our cities have already discussed the matter of participating in the Panama-Pacific International Exposition, and many of them are preparing to establish a fund for that purpose. The establishment of such a fund is lawful, except where expressly prohibited by special charters, and it is something that should be given early attention.

A suggestion has been made that everything connected with municipal exhibits be placed under the supervision of the League of California Municipalities, and such a proposition will no doubt be given serious consideration by the directors of the exposition.

## A MODEL TOWN AT THE FAIR

BY ERIC LANGE, PRESIDENT OF THE BOARD OF TRUSTEES OF TOWN OF BURLINGAME

Municipal Government is a very important and interesting branch of the science of political economy. In late years the people have been manifesting an ever increasing desire to know about the management of their municipal affairs. They are demanding a higher standard of government than at any previous time and there is no doubt that the charters for such governments are receiving a much closer attention on that account.

Political and Social Economy, two great sciences through whose medium so much good or harm may be done, should be better understood by the people as a whole.

San Francisco is about to hold an International Exposition at which will be exhibited all the best in all the arts and sciences for the purpose of educating the people, and what better opportunity was there ever offered those of us who are interested in Municipal Government than to make the exposition of this science, on a practical plan, one of the great features of the Fair. It will be the crucial moment to awaken the civic pride of all dwellers in Cities and Towns, to interest them in the City Beautiful, with its Civic Center, its Hygienic conditions, and all those things that make for a more perfect enjoyment of life.

How to go about this is the question the writer has been asking himself for months and finally it dawned upon him that through the League of California Municipalities, representing about 150 of our cities, and with the assistance of the Panama-Pacific International Exposition Co., there could be built in the Fair Grounds a model civic center. The League is in a position to interest many of the Municipalities of the country, and I daresay Europe, to enter into the scheme most heartily.

In this way municipal headquarters would be established in the Model Town where neighbors would meet, where Town and City Officials would go to obtain ideas on the most approved methods of handling the multitudinous problems of City Government.

The fundamental ideas of the Municipal Exhibit is a "Civic Center."

The planners should assume that the Town has a certain population and build their public buildings accordingly. There should be a City Hall, Court House, a Library, a School and such other structures as naturally are associated with the Government. The furnishings and special appliances in these buildings should be exhibits made by manufacturers of such goods.

Radiating from the Civic Center would be streets. One could be a business street with its Hotel, Post Office and Stores. One other should exhibit manufacturing in operation if possible. The others should be residence streets at the head of one of which should be a Church. Connected to the School a kindergarten and nursery would be self supporting and in a public park on one of the blocks a play ground would be a source of great pleasure to children.

The entire scheme should have all the accessories and features as they should be in a Model Town.

Various methods of street paving could be shown. Sidewalks, curbs, park spaces, lawns, lot line fences, hedges, street lighting methods, street sweeping, sprinkling and flushing culverts, open street gutters, etc., etc.

In the buildings could be exhibited all the devices that make for good management in municipal, business and private affairs.



Particular attention should be given to demonstrations of methods of construction.

Manufacturers of labor saving devices could do much to make the Model City a success.

As the undertaking is a large one, no time should be lost in preparing data sufficient to put before the officials of the Exposition Co., as well as the officers of the Cities of California, a concrete proposition, and with this idea in view the writer suggests that the Executive Committee of the League of California Municipalities take the matter up at once and formulate plans for the building at the Panama-Pacific Exposition of a Model City.



### AN UP-TO-DATE BRIDGE

BY E. T. THURSTON, JR., DESIGNING AND CONSULTING ENGINEER, SAN FRANCISCO

In the winter of 1909-10 there was constructed in the city of Santa Rosa, across Santa Rosa Creek, at South Davis Street, an ornamental arch highway bridge which is worthy of notice for several reasons. The structure has a clear span of ninety-five feet, built askew, with a rise of twenty-two feet and a thirty-foot roadway, including two six-foot sidewalks, constructed throughout, including the railings, of concrete reinforced with steel rods. As will be noted by the accompanying illustration it furnishes a good example of the simplicity and beauty of the arch type of bridge when intelligently designed. The building of permanent bridges, proof against fire, earthquake and the ravages of time and requiring no expense for maintenance or repairs, has been in vogue for many years in Europe and in the more populous districts of the United States, and although still a little behind, California is rapidly coming up in the procession.

The bridge under discussion is remarkable for its combination of strength, rapidity of construction and lowness of cost. An arch bridge depends for its strength on the resistance of its abutments to being thrust apart and, as ordinarily designed, this resistance has to be furnished by the foundation material at either

end of the bridge and necessitates very massive construction at these points, several times as much material going into this part as into the arch proper. In the Santa Rosa bridge however, the expedient was introduced of tying the abutments together by means of continuous steel rods passing under the stream bed, fastened at either end to the arch reinforcement and imbedded in concrete, thus taking care of the thrust within the structure itself without regard to the foundations, rendering the bridge a complete, self-contained structure, proof against destruction even should the foundations settle and, inasmuch as the concrete protection of the under-tie affords a continuous, flood-proof pavement under the bridge, rendering it practically proof against washouts. The use of the under-tie was alone effective in reducing the quantity of concrete by more than half, which resulted in a corresponding saving in cost of construction.

There is another peculiarity in the design of the bridge that operated for economy in construction and tended to encourage low bidding. It is well known by contractors that the main element in the cost of reinforced concrete work is the construction of the forms or temporary moulds in which the structure is to be cast. Ordinarily the structure is designed without due regard to the cost of this work, but in this case particular attention was given to simplicity of detail and such dimensioning as would admit of the use of stock sizes of lumber.

The actual cost of the bridge under discussion was remarkably low. The estimated cost, exclusive of macadam roadway, was \$8500 as against \$7500 for a competitive steel structure with wooden floors, supported on concrete piers. Of the eight bids received, all but one fell below the estimate and the contract was let for \$7850.00.

Another advantage peculiar to reinforced concrete construction for permanent bridges was exemplified in this construction. Owing to necessary legal formalities such as advertising, etc., it appeared that it would be impossible to enter into a contract before November, which, on account of the time required to manufacture and ship the superstructure and probable weather conditions, would render it impracticable to commence the work of erecting a steel structure before the following March. The condition of the old bridge rendered immediate action almost imperative, and the fact that work could be commenced at once on a concrete structure had some effect in influencing the trustees in favor of the latter type. That their judgment was good, is demonstrated by the fact that although the water in the creek rose to within four feet of the roadway of the bridge during construction, the structure was completed in the following February.

The South Davis street bridge was built under the general supervision of the writer and after his designs in which he made use of the patented expedients of the National Bridge Company, which made it possible to realize the economy herein referred to.



## CULVERT CONSTRUCTION

ADDRESS DELIVERED TO THE COMMISSIONERS AND SUPERVISORS CONVENTION, OMAHA, DECEMBER 15, 1910. BY MR. PETER CAMPBELL, COUNTY COMMISSIONER, SAUNDERS COUNTY, NEBRASKA

It is necessary that the water which falls on the road and which flows upon it from adjacent lands, should be got rid of as soon as possible. Culverts should

be built at low points where outlets are available, and existing streams should always be used for outlets. The water should never be carried in the side ditches any further than is necessary. When the volume of water is small, it may be carried across the road in small 12 in. pipe.

Large culverts and bridges should always be designed by competent civil engineers and constructed under their supervision. Indeed, very often the advice of such an engineer in regard to the smaller water ways might be sought with profit. Money is often wasted from a lack of knowledge concerning the proper sizes of culverts. When we first commenced the use of iron culverts, we made the common mistake of getting them too small in diameter and short in length, but we have since replaced, some with larger ones and extended others that were short.

I am not an advocate of abutments, except in rare cases, and for that reason

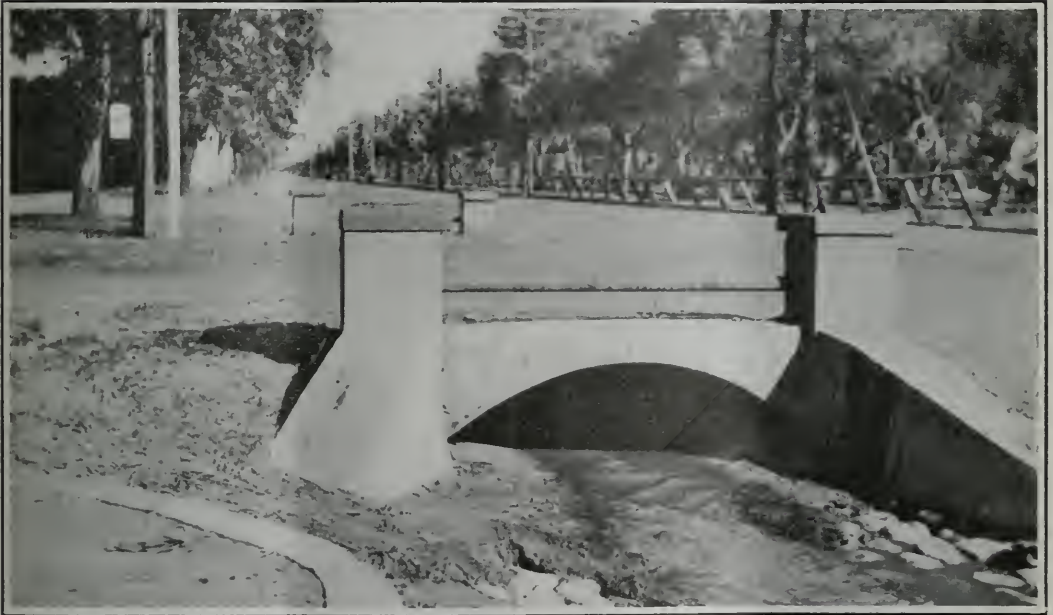

**PART CIRCLE AMERICAN INGOT IRON CULVERT 58"x19" INSTALLED AT THE INTERSECTION OF WEST G. STREET AND EUCLID AVE., ONTARIO, UNDER THE DIRECTION OF MR. B. B. MANN, CITY ENGINEER**

I have always put in the culverts about four feet longer and obtained better results than by putting in abutments. My rule has been that when a 20 ft. roadway is desired, on a 5 ft. grade, that the culvert should be at least 30 ft. long, making the angle of repose 45 degrees.

We have replaced a very large number of our 12 and 16 ft. bridges with 4 and 5 ft. culverts, making a large saving in future repairs. In some cases we have placed 30 to 50 ft. bridges across dry ravines with 6 ft. culverts and made a fill of 10 to 20 ft. by cutting down hills, and making practically a level road with no future expense.

The question of culverts has always been a serious one and has been solved by some using steel, some American Ingot Iron, and others concrete. Culverts must necessarily be made either from wood, tile, steel, concrete or American Ingot Iron. So the question resolves itself into this:



"Who has the best and most enduring material?" So much is known of wood and tile, that any reference to them here will not be necessary, as neither should be used under any circumstances for culverts, because it is an absolute waste of money. We have used more American Ingot Iron Culverts than any other county in the State, during the last six years. In the last four years, we have used more than \$8,000.00 worth per annum, and they have given entire satisfaction in every instance, except in one case, where the fault was ours and not of the culvert.

We have also used some reinforced concrete pipe, and find that some are in

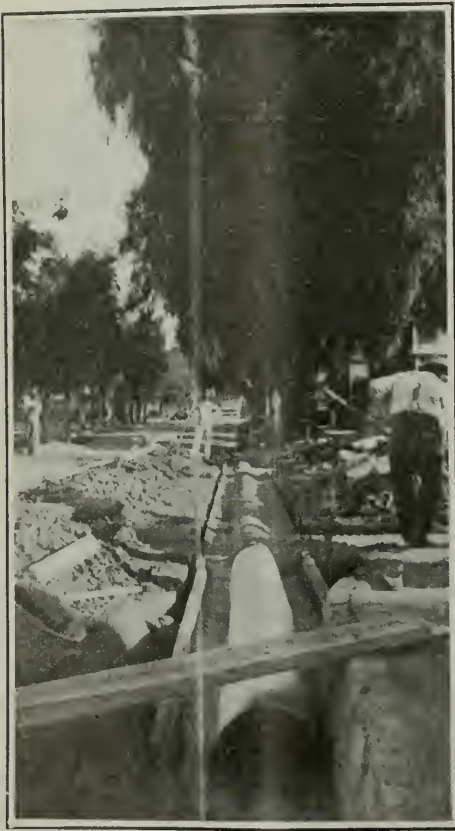

THESE PART CIRCLE AMERICAN INGOT IRON CULVERTS SHOWN AS BEING INSTALLED AT SIXTH AND LIME STREETS, RIVERSIDE, UNDER DIRECTION OF MR. A. P. CAMPBELL, CITY ENGINEER  
Size 14"x7", Main Culvert 68 Feet Long with Two Tees 17 ft. Each

good shape, while others are all cracked up, and at least two are ready to collapse, due to the action of the frost.

The Montana Agricultural College issued a Bulletin No. 69 on "The Effect of Alkali on Portland Cement," in which they advise against the use of cement in alkali soils.

I am advised that Cement Tile, at North Bend, used for drainage purposes, fell to pieces in eighteen months, due to alkali in the soil. Frost also has a ten-

dency to destroy concrete pipe either by the water freezing in the pipe or by the heaving of the earth during the winter by freezing and thawing.

The amount of land to be drained should be considered when determining the diameter of a culvert, and it is always better to get it a size larger to allow for emergency. In laying culverts, they should be laid as nearly level as possible, and they are less liable to wash out than by giving them too much slope.

I have endeavored to give you my experience from conditions as they exist in Saunders County, and possibly a different treatment is required elsewhere.



ONE OF THE MANY PART CIRCLE AMERICAN INGOT IRON CULVERTS  
INSTALLED IN THE CITY OF FRESNO, UNDER DIRECTION OF MR.  
C. P. JENSEN, CITY ENGINEER, THE MAN IN THE AUTOMOBILE



## ASSESSORS' DUTIES WITH MODEL FORMS, RECORDS AND MAPS.

BY D. D. KELLOGG, ASSESSOR OF PASADENA

Before the Department of Clerks, Auditors and Assessors at San Diego, Nov. 16, 1910

The Assessor or administrative head of the assessing department should be appointed and not elected; and when appointed should only be removed for cause after a hearing.

Associated with the Assessor there should be an advisory board who together with him should act as a board of review and pass on all questions which should properly be submitted to the board rather than to a single official.

In small cities a board of two or three members would be sufficient, and their duties would probably be confined to reviewing the work of the Assessor, which would take only a few weeks in the course of the assessment period.

In small cities the members of this board should be appointed from the members of the City Council; the experience and information gained as members of the

advisory board would be of great value as members of the equalization board, of which, in small cities, they would be members.

In the larger cities the Assessors who perform the actual work of appraisal should give their entire time to their work,—while in the smaller cities the office of Auditor or Clerk may be combined with the assessing department, which would enable the offices to be administered with more economy than if kept separate.

A good system of assessment requires accurate maps which should be corrected each year so as to show all new subdivisions or changes of record made; the maps should contain columns for the names of owners and final assessment valuations of real estate and improvements for several years, which not only assist the assessor in fixing values in subsequent assessments, but a record of easy reference for data often sought by property owners as well as the general public.

I will say further in reference to forms of assessment maps, I have found a double page map the most convenient form; on one page a map of tracts drawn at an accurate scale, giving names of tracts, subdivisions, streets, etc., size of lots, and width of streets, also marginal figures indicating number of map on which adjoining property may be found. The opposite page is devoted to description of tracts, lot numbers, the owner's name, values of land and improvements, so arranged that several years records may be had on the page; space being allowed for change of owner, subdivision of lots or plats, thus giving a complete and continuous record for a term of years—each double page being a complete assessment record of the property indicated.

These maps should be bound in volumes of suitable size, with a key map in the front, also a small book of convenient size containing tracts, subdivisions, etc., giving the maps on which they may be found; I have also found a key wall map, giving map pages and showing location of tracts and subdivisions, very convenient.

Besides the map books and records as described above, there should be field books for each deputy. These field books should contain maps and description of subdivisions and tracts, the size of the lots, and columns for names of owners, street and number of house, and value of same, also personal property, and a wide column for remarks.

I have with me samples of the map and field book which may be examined by any who may be interested or wish to make further enquiry.

The Assessor, being equipped with maps and field books, with all available data, should then determine the value of the land per front foot for a unit in depth—which in smaller cities should be for the business sections 125 feet to 150 feet, and for the outlying or resident districts, the unit depth should be 150 feet to 170 feet.

When lots are shorter or deeper than the unit established, the value must be obtained in accordance with a scale which experience shows is suitable for the particular city.

Lots situated on street corners are of more relative value than interior lots, and should be valued higher in proportion to the importance or character of the streets on which they front.

The increase in value due to a corner position extends from 100 feet to 150 feet in each direction from the corner for resident or outlying lots, and from 50 feet to 100 feet for business lots, depending largely on the location of the lots.

Key lots should receive a discount of from 10 per cent to 20 per cent, the amount of discount to be determined by the relative position or location to the adjoining lots.



Lots adjoining a railroad in the outlying or residence districts also should be subject to the same discount, but lots situated in what would be termed the wholesale or shipping district should not receive this discount—the shipping facilities, on account of sidetracks, etc., benefitting rather than depreciating the property for the use to which it is put.

In determining the value of buildings or other improvements in cities where permits with values of buildings and improvements are issued and records are kept, *these* values may be taken as a basis for valuations.

In placing values on realty, I have found that a map of convenient size assists very materially in making uniform valuations and in comparing values of adjoining property; giving, at a glance, a connected statement of valuations in each section or district, and after valuations have been placed on these maps they can very readily be transferred to the assessment map books.

After an experience of over twelve years in assessing city property, I may safely state that no assessor can make, or has been known to have made, an assessment that has been, or will be, entirely satisfactory to all of the property owners.

Our laws require the Assessor to place valuations on all property, and he alone is responsible for the assessment, and under existing conditions it is equally impossible for an Assessor to make an assessment that is wholly satisfactory to himself.

If, however, the Assessor could have the assistance of an advisory board as has been suggested, to review his valuations with him, and for consultation, etc., it would help very much toward making a more satisfactory assessment.

To ascertain the value of land, the Assessor is confined to the enquiry as to what other people think of its worth and what they will therefore pay for it. Each particular sale of land is merely evidence of what certain persons think the land is worth. The price paid may have been influenced by considerations peculiar to the particular sale, and the price paid is never conclusive evidence of value. Sometimes a man is pressed for ready money and sells a piece of land for less than it would bring if more time had been devoted to the search for a purchaser. Sometimes one desires a particular site for a particular purpose or to enlarge a parcel he already owns, and because of his desire for that particular site he is compelled to pay a larger price than one would pay who merely sought a piece of land of like location or character.

To determine the value of land with the greatest accuracy, it is necessary to secure as nearly as possible the opinion as to value of the largest number of persons who help to make the market, either by being themselves buyers or sellers, or the advisers of the buyers or sellers.

In view of these conditions, the greatest problem before the Assessor is as to the best way in a given time and place to secure the benefit of the community opinions of value.

Different methods have been employed in various cities to secure the widest expression of community opinion as to the value of land for the guidance of the assessing department, and the best method must very likely be determined with reference to the conditions of the particular city or at the given time.

A method which will work well in a small city may be impracticable in a larger city.

There are many problems of this nature that must be worked out by the individual Assessor.

In placing values on personal property the Assessor has to rely almost entirely upon his own judgment and knowledge of this class of property, and unless very

careful, the property of small holdings or households is apt to be assessed at a greater proportionate value than the larger holdings.

What may be termed intangible property—foreign stocks and bonds owned by residents of the state, is the most difficult class of property to reach, so far as assessing is concerned, and but a small per cent of such holdings is reached by the Assessor; in nearly all cases it is wholly with the owner of such property, the value, if any at all, that is entered for assessment.

Quoting from a report to Congress of a tax commission for the District of Columbia,—“It is the testimony of experience that a tax on intangible property tends to inequality in taxation instead of fairness, and those who are especially intended to be taxed are the ones who escape——, a school of forgery—worst of all, it imposes unjust burdens upon various classes in the community.”

The assessment of banks and public utilities is another phase of the assessing problem that is quite difficult to handle satisfactorily.

It is a well known fact that statements made by some banks for the Assessor, from which he is expected to make the assessment, are very different in some respects from that made only a few days previous or subsequent to the bank examiner and for publication.

The Assessor is supposed to have ample authority to correct such seeming irregularities, but the laws in regard to bank assessments are a little ambiguous, and even our legal department cannot quite agree as to what the Assessor is empowered to do; hence, it is left with the individual Assessor to decide what line to pursue,—trusting to the equalization board to sustain him, or otherwise.

In assessing public utilities the Assessor meets with more difficulty in his attempts to make a “fair and just” assessment than with any other class of property, and the larger the company and the more holdings represented, the more difficult the problem becomes.

In some cities public utility companies are required to file an annual statement, which is supposed to show their holding, gross receipts, etc.; this, if properly made, may help the Assessor somewhat in establishing values.

In addition to the assessment of the tangible property, public utility companies, as well as banks, are subject to assessment for franchise.

In arriving at the value of a franchise in most cases in which a public utility company is concerned, the Assessor has very little reliable data to assist him, therefore the value fixed by him is apt to be determined from his personal opinion—governed largely perhaps by his judgment as to the earnings or earning capacity of the company.

In the case of bank franchises the value may be arrived at by deducting the tangible assets from the liabilities and market value of the Capital Stock; or, the difference between the book value and the market value of the Stock will represent the value of the franchise.

If Constitutional Amendment No. 1 is adopted there will be some radical changes made in assessment of Public Utility Companies which may eliminate much of the difficulty that the local assessor has now to contend with, but whether the results will be more satisfactory remains to be demonstrated.

A very interesting article on personal or intangible property tax may be found in the July issue of the “Journal of Accountancy,” published in New York.

Our method of taxation in many respects is very crude and unsatisfactory and should be revised, but how it can be done and who can offer a better system are questions that this section of the League cannot well determine; so I will put the question up to our legal department.

## PROCEEDINGS

## THIRTEENTH ANNUAL CONVENTION

OF THE

## LEAGUE OF CALIFORNIA MUNICIPALITIES

HELD AT

SAN DIEGO, CALIFORNIA, November 15th to 19th, 1910

## BEFORE THE GENERAL BODY

FRIDAY, NOVEMBER, 1910, 9 O'CLOCK, A. M.

The convention was called to order by President Evans, who introduced Mr. William Dolge.

## IDEAL MUNICIPAL ACCOUNTING

Accompanied with Stereopticon Views

BY WILLIAM DOLGE, C. P. A.

To concentrate into a few clear and concise statements a complete expression of the operations and the conditions of an undertaking,—that is the purpose of an efficient accounting procedure.

Correct accounting is fundamentally necessary for effective regulation of the affairs of every undertaking, public or private. A Municipal government, administered without the information that can be derived only from correct accounts, is an administration led or misled by fear and favor, by guess work, by prejudice and by superstition. Honest accounting is not necessarily correct accounting nor scientific accounting. Every dollar disbursed by the treasurer may be honestly accounted, yet so recorded as to lead to wrong conclusions. (Figures do not lie, but not all mathematicians are honest.)

A tabulation may be arithmetically correct, the columnar footings and the cross-footings be equal even to the fourth decimal point, and yet the table may be quite wrong.

At best, it is possible only to present the briefest outline of the subject before us. So let me plunge into the heart of it at once and let us consider the requirements of ideal municipal accounting.

The accounting procedure is the tool, the servant of the administration. However complex it may be in its operations, the result should be clear and concise statements, that may be readily understood, not only by the City fathers or the department heads, but by the average citizen.

After all, the problem of administering a municipality is in no wise different from that of operating a business or even a household. There are receipts from a limited number of well-defined sources, taxes, licenses, court fines, revenues from municipal public service industries and miscellaneous. Nothing complex here. Taxes may be classified as real property and personal property taxes. Licenses may be segregated into liquor, business and dog licenses. Electric plant revenues may be segregated into power and light, but a more detailed segregation should



not appear on a general statement. The detail should be prepared, of course, for the guidance of the department head and should accompany the main statement.

When we take up expenditures, the problem appears complex but it is just as simple. Once the general classification is determined, the remaining difficulties are nominal. The auditor or city clerk will not be called upon to solve problems such as confronted the voucher department of the San Francisco Relief Corporation when the question arose, whether a car load of nursing bottles should be charged to the general account, Relief of Hungry, or to Relief of Sick and Wounded.

Auditors and clerks are not asked to determine six, or eight or ten general classifications of expenditures. They are asked only to adopt the classification recommended by the National Municipal League, the League of American Municipalities, the Union of Canadian Municipalities and kindred organizations, which classifications were adopted by the Bureau of the Census and by practically all cities that are leading in Municipal affairs.

These classifications are the basis for uniform Municipal reports and uniform Municipal Accounting procedure. They are the result of ten or more years study of municipal problems by master minds all over the country and were finally adopted as conforming to the greatest possible variety of conditions.

Can you think of a municipal function that is not comprehended within?

General Government, comprising the administrative departments.

Protection of Life and Property, ie., Police, Fire and Pound.

Health Conservation and Sanitation, ie., Health Department, Street Cleaning and Sprinkling, Sewer Cleaning, etc., Charities and Corrections, ie., Jails, Hospitals, Poor Relief, etc.

Recreation, ie., Parks, Play Grounds, Celebrations.

Education, ie., Schools, and Libraries, Museums.

Streets and Highways, ie., Repairs, Lighting, Improvements.

Public Industries.

(SLIDE NO. I. BUDGET)

If we are agreed that this grouping is as correct as it is concise, we have taken the first step toward the scientific preparation of the Budget.

A Budget is defined as the financial statement of a government, showing estimated revenues and probable expenditures. Even the wage-earner considers a Budget, if not for a year in advance like a city, then at least from one pay-day to the next. Definite sums are set aside, if not actually, then mentally, for rent, for food, for clothing, for amusements, for sickness, etc., and the man who does not do this is called improvident and will more than likely find himself in debt before the next pay-day. A city is no different except that the amounts involved are larger.

The amounts to be set aside for each purpose are determined by past experience and the more accurately the past expenditures have been accounted, the more accurate the Budget estimate will necessarily be. If our Budget is properly prepared we have a safe guide for the year and experience will teach us wherein we must make changes.

Now how is this Budget prepared? In order to determine the amount needed to be raised by direct tax on real and personal property, we must know the estimated necessary expenditure for the year and the estimated revenue from licenses and from other sources. We can of course, fix the tax rate at the maximum allowed by law and let it go at that. One town whose treasurer always reports his

payments as "Dis bust-ments" (perhaps because the town treasury is always busted) does this. And joking apart, that is the one real reason for the empty treasury.

In considering the expenditures in the preparation of the first Budget we have the choice of analyzing carefully the previous year's work and basing our estimates upon this, or working independently to arrive at proper figures.

(SLIDE 2, SCHEDULE B.)

Thus Schedule B. General Government will not present many difficulties because most of the items are fixed. We know what the salaries are because they are fixed by ordinance or possibly by charter. We should be able to determine the amounts necessary for the publication of ordinances and for auditing.

A real live clerk would have his filing cabinets selected six months before the Budget was made up and the amount for that purpose is thus fixed. Election expenses, cost of maintaining buildings and the miscellaneous items may be determined with the same accuracy and to allow for unforeseen emergencies of minor character we have set aside a small contingent sum.

There is not space, nor is it essential to consider each main classification of expenditure in the same detail here as in Schedule B. Suffice it to say that each schedule should be prepared in the greatest detail possible. No lump sum for salaries, but each position designated by name of official or employee, by character of duties and by amount of compensation. No lump sums for maintenance or operating supplies, but detailed statements of the quantity, kind and price of each commodity needed.

Properly prepared these statements will enable the Budget Committee, the Board of Trustees, the Newspapers and the interested citizens to criticise them intelligently and thus bring about one main purpose of the Budget—economy in expenditure.

As originally prepared the amounts necessary for current operation and maintenance expenditures would of course be stated separately from expenditure for improvements, Capital expenditures as it were, such as a filing cabinet, or an adding machine for the clerk, a new engine for the fire department, a sprinkler for streets, a new green house in the park, more furniture for the library, more lamps for the streets, etc.

This, because the administration must be in a position to determine absolutely what the necessary expenditures for current purposes are and to use its discretion relative to paying for improvements out of current revenues. Else it is quite possible that the department's Budget estimate will call for \$590,000, as did that of the Department of Electricity in San Francisco some years ago, deemed necessary, imperatively necessary by the department head, but nonetheless cut down to \$57,000, by a well informed and heartless Finance Committee.

The Budget as adopted is the foundation for the accounting proper. Ledger accounts are set up for the estimated revenues and expenditures. The estimated revenues are asset—or debit accounts. The estimated expenditures are liability—or credit accounts. Accounts are also opened with the various funds, and with Surplus as credit to offset the balance on hand at the opening of the books.

Then as the revenues are received they are charged to the various funds (the treasurer) and credited to the revenue accounts, making it possible to produce directly from the ledger the Revenues Statement, showing in separate columns the amount collected, the Budget estimate, the balance uncollected and excess collections, for each kind of revenue.

## PACIFIC MUNICIPALITIES

## SLIDE 3. REVENUES STATEMENT

There are many different forms of claim or demand and warrant registers, but all ultimately show the total amount of claims allowed each month. This sum is the charge against the estimated expenditures and the credit to the several funds. The charge to the individual ledger account is made directly from the face of the combined demand and warrant.

## SLIDE 4. DEMAND—OBVERSE

This portion of the demand never leaves the possession of the clerk or the auditor.

By the way of interruption we also show the other side of this demand form.

## SLIDE 5. DEMAND—REVERSE

Not because it is germane to this particular part of the subject, but because we all like to look at a warrant—even a blank warrant.

## SLIDE 6. APPROP. EXP. &amp; BALANCES

To prove the arithmetical accuracy of the ledger a trial balance must be drawn off and there is no reason for not drawing it off directly on the Statement of Appropriations, Expenditures and Balances.

But for the Board of Trustees and the newspapers this is too long and too complicated and so we make up a recapitulation of appropriations, expenditures and balances which shows the same facts in concise form.

## SLIDE 7. RECAPITULATION OF APP.

There are many other subsidiary forms that can be suggested for municipal accounts but there is only one other form required for the concise and correct information deemed necessary in the opening remarks. That is the Treasurer's report.

## SLIDE 8. TREASURER'S REPORT

You will note that only a few funds are provided for and that the report is shown in two forms, horizontal and vertical. The information conveyed is the same in each.

The treasurer's report is essential because we must know whether all the moneys collected have actually been deposited with him. The treasurer's balance of each fund must be equal to or greater than the balance reported by the auditor or clerk, because there are always outstanding warrants. In other words we are going to base our accounting on revenues and expenditures, not on cash receipts and cash disbursements. We are going to stop drawing checks when our check book, our appropriation statement, shows that the balance is low, and not depend upon the bank's balance, which is large only because some checks have not been presented.

## SLIDE 1. BUDGET

Subsidiary books, clerks, auditors, treasurers, marshals, and tax collectors, registers, all lead up to the facts recorded in the ledger and all are checked by the ledger accounts as to their integrity.

The Budget and an accounting procedure based upon the Budget, properly maintained should result in increased revenues, in economy of expenditures, in comparison of the efficiency of one administration with the efficiency of another,



in comparison of your city with other cities and finally in the complete logical expression of the operations and the condition of your municipality in a few clear and concise statements.

THE PRESIDENT. We will hear from Mr. Baker, the engineer of the State Board of Health.

## THE QUESTION OF SEWAGE DISPOSAL

ADDRESS BY N. G. BAKER, ENGINEER OF THE STATE BOARD OF HEALTH.

MR. PRESIDENT AND GENTLEMEN: I want to explain briefly the relation of the State Board of Health to the municipalities and to the engineers practicing in the State, in the matter of sanitary engineering. For a good many years the State Board of Health has had inquiries from time to time, and requests for advice, from small municipalities and individuals, and it was not until about a year ago they saw fit to do anything definite in the way of collecting information of this kind. The first piece of work that was undertaken by the Board was an investigation of the stream pollution in the State, the pollution of the sources of water supply. There is a State law in California, a very stringent one, too, which prohibits the pollution of streams that are sources of public water supply, but it is a well known fact that there are a good many violations of that law going on at the present time. Inspection was made, with the view of finding out what was done in these violations, and to find out what was the extent of these violations, and to what extent the water so polluted was used for water supply. The inspector was sent to make a detailed study of most of the rivers in the State. That took several months. The rivers studied were the Sacramento River, San Joaquin River, Truckee River, Russian River, Santa Ana River, Pajaro River, and Salinas River. In the study of those rivers, the inspector went to each one of the important towns on the stream, and noted it in its relation to the river, whether it put sewage into the river, and to what extent this was done, and whether it took water out of the river for water supply. The report on that was made to the Board. Then, for the general information of the Board in matters of sanitary engineering, most of the larger towns in the State were visited, and an engineering report was made on the water supply and its amount, the amount used and the cost of it, and the question of sewage disposal. Of course, these reports were very hurried, and no detailed studies were made of the apparatus used. Then, in addition to that, there were special engineering reports. The statement made by Mr. Gilliland might lead to a little confusion and misunderstanding, and I think a little explanation is due. It is not the intention of the Board to make a report to any of the towns and tell them all they want to know. It is not the intention of the Board to intrude their advice on any town that does not want it. Every one of these State inspection and engineering reports has been made on request from head officers, city officials, or individuals. It is because the people wanted exceptions made and wanted advice of the State Board of Health that the Board has done that. As a matter of fact, they have not the means and they have not the money to spend to go out and make inspections for people who do not want them. They might do it later, but conditions would have to be a great deal different from what they are now if they do.

You might be interested in the plans outlined for the next year. The most important part of this work I think is the study of the sewage disposition plans in

the State. A few weeks ago a letter came into the office of the State Board of Health from a city engineer who was planning a new sewage works for his town. He said they had planned the works, but had not begun construction, and before they began construction, he wanted to investigate and find out everything he could about this plant over in Santa Monica, for example, because he had seen a newspaper or magazine article on that plant, and he did not know but what that plant, or a plant similar to that, would be better fitted for the needs of his city than the one he had planned. For that reason he wrote to the State Board of Health, asking advice, assuming that they had made a study of the plant at Santa Monica. With the means at hand, the State Board sent down to do that. It is the desire of the State Board to make a careful study of that and of a number of plants, so that when inquiries come in we can give the information, not the opinion of the State Board or of the engineering department, but definite, indisputable facts, and then the engineer can form his own opinion. The Board proposes, for example, in the case of the Santa Monica plant, to put a trained chemist on the job, and let him take samples every half hour for several days, let him stay there a week, if necessary, take samples, make careful analysis of those samples, determine the amount of sewage treated, and the cost of treating, and the results accomplished, and then when anyone writes to us and asks for advice as to whether or not this kind of a plant would be adapted to the use of his city, we can tell him what the plant has done and he can draw his own conclusions. In a case like that, the amount saved in giving this man definite advice and keeping him from spending \$10,000 or \$15,000 for his city, will pay the expenses of the engineering department of the State Board of Health for three or four years.

In one part of the State there are several plants being built for the treatment of sewage further than the septic treatment. In Southern California I do not believe you have a plant that treats sewage any more than the septic treatment. It is only a preliminary treatment. In order to purify the water, you have to treat it further than that, and put it through some oxidizing and nitrifying process. That sort of work is very new in California. I don't believe there is a big plant in operation in the State of California, and I have been around the State looking for it. But four plants have recently been devised to accomplish that sort of treatment. The man who designed these plants designed them without any previous experiments as to the method that they intended to use, previous local experiments. They are designed, as you may say, purely on theory. It is not to the advantage of the city of Roseville, for example, to adopt this plant for the purification of sewage, without making a careful study to determine whether it is efficient. If they find out it is not efficient, they would be disappointed, and would have spent their money. It is very plainly the duty of some authority in the State to make a study of the plant and find out where it is deficient, and note the features that make for efficiency as well as for deficiency, and make that information public, because other plants are going to be planned more or less from that, one at Santa Clara, one at Fresno, and so on. So the logical people to do this work of experimentation are those of the engineering department of the State Board of Health. They should make studies of those plants and should make that information public. Every hundred dollars spent in that way may save thousands for the municipalities of the State putting in plants for themselves.

We propose also to make studies of the septic tanks, and I think it would be well to do so. Of course, these plans are only tentative plans, they are not definitely worked out at all. But we hope to make those studies, and as well to make studies of irrigation in the State. A great many of the towns have used raw

sewage, as at Pasadena, as well as with septic sewage, and there is irrigation with sewage going on all over the State. People locally know about the situation, but nobody has made a business of going to all these places and studying the situation. Mr. Lathrop, of San Bernardino, this morning in the discussion on the streets, made a very apt statement, that the State needed some central authority to take up the question of street paving, and to study it and collect the information that has been gotten from experiments made in the different towns in this State. I hold the same is true of sewage disposal and sanitary engineering in general. There should be some central authority to gather this information and have it on record at some place in the State, and I think that place should be the State Board of Health engineering department, so that municipalities designing plants can come there and get the experience that other towns have had, and they need not go ahead and spend money in mere experiments. I have been on sewer farms where they were monuments of forlorn enterprise, and had cost thousands of dollars. I have one in mind where they spent enough to build two or three good septic tanks, and if they had only had the experience when they commenced with their plant, instead of after, they would have saved themselves a very great deal.

We can very well establish small experiment stations for this purpose. It has been suggested that this be done, with reference to sewage disposal, at the twelve or fifteen State institutions of the State, establishing there independent sewer systems and sewage disposal plants. It may not be possible for the State Board of Health to accomplish that this year, but it is policy to do it some time.

There are a number of the eastern states that have engineering departments in their State Boards of Health. Of course, it is something that will not spring into life full grown, but must start from a small beginning. The State Board of Health of California has not had an engineering department and has not one now. They have simply hired one man with engineering training, and very little experience, and started out to collect this information and put it on file in the office of the State Board of Health, and to finance part of the work, they have taken the money from various funds of the State Board of Health, so that they can make a showing, show the nature of the work to be done now and in the future. Then, if it is deemed fit by the powers that be to put it on a permanent basis, we can make a better showing in another year.

I am sorry I did not have the lantern-slides to show to the city engineers the plants around the State. Some of the engineers have seen the plants in their immediate vicinities, but very few of them have seen the different ones all over the State. I do not think there is any particular thing in engineering in which there is so much difference in this respect as there is in septic tanks.

It is not the policy of the State Board of Health to furnish towns with expert engineering services, but simply to act in an advisory way, advising them in matters of policy. Another thing: The State Board of Health is in a way compelled to act as a sort of referee in matters of intertown relations. Here is a town on the river, and another town ten miles down. The upper town dumps sewage into the river and the lower one takes its water supply from that river. It is a very tedious matter to have it up in the courts, and if it can be taken up in the State Board of Health, it seems to me the State Board is doing a good deal of good work. In the last few months, the State Board has made preliminary surveys for several small towns, and I think it is right and proper to give a few of the conditions that led up to these preliminary surveys. They are something like these. Here was a small town with no sewers. They had cesspools and privies and shallow wells all over the town, promiscuously, which created a condition very dangerous to the



public health. Another condition was that the town had no city engineer, no person in their employ to whom they could go for engineering advice. Another condition was that the town had at the time contagious diseases, typhoid, for instance, which gave the State Board of Health the opportunity to step in and study the situation. In several other cases, complaints have come to the Board of a nuisance from flies in the town. The procedure the Board went through in such cases was to send the engineering inspector to look over the town and to decide whether or not it was feasible to put in a sewer system, to get a map of the town and the number of blocks in the town that were occupied and that would need sewerage at the present time to relieve the then condition existing, and to get some idea of the slope of the streets, to consult the engineer, if there was one, and get an idea of the directions and elevations upon which sewers could be run, and decide on the disposal of the sewage if there were sewers built, and give the people an estimate as soon as conditions warranted of the cost that would be entailed in putting in a sewer system. That advice was merely preliminary. The report of that would go to the city trustees, and the report would not be a report that the town could use in a very definite way in putting in sewers. They are always told that the report is merely preliminary, to give them some approximate information, and that they would have to employ for this a sanitary engineer to make a more careful study, and to make a more close cost estimate and work out the engineering details. So, instead of taking work from sanitary engineers, the State Board, in doing such things as that, really makes work for the sanitary engineer. In a great many cases a town will not take up the question of sewerage, because they think they can't afford it. If the State Board can come in and make a reasonably close estimate, even though 25 per cent off, then they can take up with the city council the subject and talk around town and find how the sentiment lies, and finally get up enough interest in the matter to hire an engineer to make a careful study of it and give them a close cost estimate.

Another piece of work that the Board has been called upon to do in two or three instances is passing on plans for proposed sewer systems. Before the Board can intelligently pass on plans for sewage disposal, they must make a careful study of the plants that already exist, and this they are doing, and the data is not complete as yet, though it is being added to all the time. The Board is then called on in several instances to pass on plans for proposed sewer systems. The advice given upon propositions of that kind has necessarily been very general. It has been largely a matter of policy and the details have not been very carefully gone into. But, as the State Board acquires more information on the subject, their services in that respect will be more often sought, and they will be more useful.

I think perhaps it is premature in this State to pass laws, as they have in Ohio, requiring that all sewer systems be passed on by the State Board of Health. But the time will come when such a thing will be advisable and will be gladly lived up to by the community. I thank you. (Applause.)

THE PRESIDENT. We are glad to hear once in a while what the State Board of Health is doing, especially as there are so many people who do not really know what its work is.

## QUESTIONS AND ANSWERS

---

This department is for the use of city officials only. City Attorneys or others who may dissent from any opinion or answers given, or who may be able to give additional information of value on the subject of any inquiry, are earnestly requested to write us at once in order that we may transmit such further information to the official making the inquiry.

Q. At a meeting of the Board of Trustees held on the above date the City Clerk was directed to write and ask you whether the Field Notes made by the City Engineer in the discharge of his duties as such City Engineer, are the property of the City employing him, or are they the property of the Engineer?

ANS. In reply to your inquiry of March 14th, will say that the field notes made by the city engineer, in the discharge of his duties as such engineer are the property of the city employing him, and not his property.

Q. A member of the board of trustees of our town (6th class) has tendered his resignation and the four remaining members cannot agree upon his successor. How can we break the dead lock?

ANS. Section 854 of the Municipal Corporation Bill gives the method for filling vacancies, but does not provide a remedy in case of a dead lock. However, Assembly Bill 1067, which has just been passed, was designed to cover just such cases. It provides that if the remaining trustees fail to appoint a successor within thirty days, they must call a special election.

Q. Are there any cases in which the President of a board of town trustees may decide a tie vote as presiding officer?

ANS. On points of order or questions involving parliamentary procedure, the president of the board should not vote except in case of a tie, but on the appointment of officials or the adoption or rejection of resolutions or ordinances, he votes the same as any other member.

There are cases where the presiding officer of a deliberative body has one vote as a representative and an additional casting vote in case of a tie, but this does not apply to the president of a board of trustees as his duties are merely ministerial, and no additional powers are conferred upon him as president.

Q. In section 869 of the Municipal Corporation Act in regard to Cities of the Sixth Class, it is provided that the City shall pay the expense of putting in street crossings. Does this provision apply to alleys, or will the owner of a corner whose lot extends back to the center of the alley have to pay for the crossing where the sidewalk crosses the alley at its junction with the main street?

ANS. Although the language is not clear on this point, we believe it was the intent to include street crossings over alleys.

Q. 1. Party arrested for obstructing Third Street by fastening a boat to the city wharf at the place marked with a red cross on the diagram herewith enclosed. You will notice the place where he tied his boat is at a point extending beyond the platted blocks of said town. Defendant's contention will be that Third street does not extend beyond the corners of platted land, notwithstanding that the waterway has been used as a public highway for a great number of years.

Q. 2. Are there any rules regulating extension of streets either by use or otherwise?

ANS. In response to your inquiries will submit the following authorities with the hope that they may be of some service:

"Low water mark of navigable water is the usual terminus of a street."

Mayzata vs. Great Northern Ry. Co. 50 Minn. 438.

"Where the seashore belonged to the State, the public's right to use it for passage, navigation and fishing, extends to all lands below high water mark not used, built upon, or occupied so as to prevent the passage of boats, etc."

Rhode Island Motor Co. vs. Providence, 55 Atlantic 696.

"Statutes are valid providing penalties for obstructing, encumbering, or interfering with a public pier or bulkhead."

Pilot Commissioners vs. Erie Ry. 41 N. Y. 619.

"A town has a right to lay out a way or a road between high water mark and the channel of a navigable river, yet a highway cannot be laid out so as to interfere with navigation."

Hunt vs. Conn. Mass 307-67 N. E. 966.

You might pass an ordinance providing a penalty for obstructing, encumbering or interfering with the public pier or bulkhead. Such an ordinance would be sustained according to the decision in the case of Pilot Commissioners vs. Erie Ry. 41 N. Y. 619.

Q. Is it possible for property owners in the vicinity of a proposed sewer farm site to enjoin its establishment?

ANS: Yes, if they can show beyond a reasonable doubt that its establishment at the point proposed would constitute a nuisance and be a menace to health.

Q. We are experiencing a good deal of trouble in disposing of our garbage. Can you tell us how other 6th class cities manage the matter?

ANS. We are informed that Mr. C. E. Moore, City Engineer of Santa Clara, has constructed several destructors for small cities. You might write to him.

NOTE. If any of our readers can give additional information in this matter, kindly send it to the trustees of Glendale.

Q. Gentlemen: We have a trustee who is so well qualified as a roadman that it is the desire of the other trustees and the public generally that he take charge of all road and street work, and draw pay the same as other men who work upon the street. How can this be done in such a way that his bills may be legally paid by the trustees?

If we appoint someone else to be Street Superintendent could he legally hire the said trustee to do the work?

ANS. There is nothing in the law relating to cities of the 6th class preventing you from taking the action you desire, giving one of the trustees charge of all the street work and paying him for his services.

Q. I am enclosing an ordinance providing for the construction of sidewalks in our city, with the request that you give your opinion as to whether, with the power given the Board of Trustees by Section 869 of the Municipal Corporation Bill, the notice prescribed by Section 12 in the enclosed ordinance is sufficient to give the city a lien to collect the cost of construction of the sidewalk in case the owner neglects to construct the same. Also, if, in your opinion, it would be better and safer for everybody concerned to proceed with construction of the sidewalks under the Statutes of 1909 regulating the construction of sidewalks and gutters within Municipalities.

ANS. Section 869 of the Municipal Corporation Bill, relates to the general powers of the trustees to enforce street and sidewalk improvements, while the different improvement acts provide the particular methods under which proceedings must be taken in order to enforce the collection of assessments.

Would advise you to wait a few weeks until the legislature disposes of Assembly Bill 1339. This bill was prepared by City Attorneys of the League and will be the best act for you to use. It will probably become a law.



Q. I noticed in the February issue in answer to a question that you state "A Justice of the Peace of a township has no jurisdiction to try a case for violation of a Town Ordinance in cities of the 6th class." If there is no recorder, and the trustees can find no one to take such office, would his assuming jurisdiction in levying a fine under an ordinance be void?

Would there be anything to prevent the Justice of the Peace of the Township, who is also Town Attorney, being appointed Town Recorder of a city of the 6th class?

Was section 1457 of the Penal Code made to refer only to city justices?

Would the Town Attorney be entitled to extra compensation for prosecuting an action in the Recorder's Court or conducting or defending a civil case in Superior Court?

ANS. Replying to your inquiry of March 13th, will say: first, it is mandatory of the trustees to appoint a recorder. Section 851, Municipal Corporation Bill. Second, the recorder's court has *exclusive* jurisdiction of all actions for the recovery of any fine, penalty or forfeiture prescribed for the breach of any ordinance of such city or town, Section 882, Municipal Corporation Bill. Third, there is nothing that we know of to prevent a Justice of the Peace of a township, who is also town attorney being appointed *town recorder* of a city of the 6th class. Fourth, Section 1457 of the Penal Code relates to city justices only, and should be read also with Section 1470, covering the same subject. Fifth, the only circumstances in which a town attorney is allowed extra compensation are specified in Section 879 of the Municipal Corporation Bill.

Q. Is it necessary to fix the grade of streets by ordinance?

ANS. Yes, it is the invariable custom, and absolutely necessary when street improvements are commenced.

## LECTURE ON THE MOSQUITO PEST IN SAN MATEO

---

On Saturday evening, February 18th, an illustrated lecture was delivered in San Mateo on the mosquito pest. It was held under the auspices of San Mateo, Burlingame and Hillsborough, jointly, and supervised by the League of California Municipalities and the State Board of Health. Attorney Kirkbride and trustee Morse of San Mateo, and secretary H. A. Mason, represented the League, while the State Board of Health was represented by Dr. Russ of San Francisco. This meeting is expected to be the forerunner of many more of a similar character to be held in other cities and towns throughout the state.

The League officials and officials of the State Board of Health are anxious to keep up the good work inaugurated at San Diego, and plans are on foot to have these illustrated lectures on health and sanitation delivered throughout the year in our different cities and towns. The State Board of Health has made arrangements to procure gratis, the services of the most talented medical men in the state who have agreed to visit neighboring towns and deliver these lectures.

City officials who would like to have such a meeting or lecture conducted in their town, will kindly correspond with the League headquarters.

## What the Cities are Doing

Fowler has joined the League.

Santa Paula's sewer system is well under way.

Fullerton has voted \$90,000 for a union high school.

Chico business men are agitating for paved streets.

Dorris has voted \$12,500 bonds for a municipal water system.

Ontario trustees are planning additions to their water system.

Santa Clara will vote bonds for the extension of its sewer system.

San Jose is about to vote on a \$200,000 bond issue for a new high school.

Oakland wants to purchase a machine for patching oil-macadam streets.

Chico will receive bids on April 18th for a new automobile chemical engine.

Porterville is talking of building a class "A" re-inforced concrete school building.

Bakersfield has commenced proceedings for the pavement of 36 more city blocks.

Vacaville is about to vote on a bond issue for septic tanks and concrete bridges.

Placerville residents are planning to widen and beautify their principal residence street.

Santa Monica fire commissioners advocate a \$25,000 bond issue for automobile fire engines.

Fairfield is about to macadamize Texas street between Washington and Pennsylvania Avenue.

Lemoore has voted \$16,000 for a sewer system. There was but four votes against the proposition.

Ukiah is having plans and specifications prepared for the construction of a City Hall and fire house.

Willows secured a premium of \$1972 on its \$40,000 bond issue, recently voted for a City Hall and fire equipment.

Hayward trustees are agitating the building of a Town Hall and a new fire house. A \$25,000 bond issue is proposed.

Merced residents have petitioned for the paving of 22nd Street between G and L streets with asphalt macadam.

South Pasadena trustees have removed the last obstacle in the way of constructing a \$160,000 bridge over the Arroyo Seco.

Pasadena voted on March 24, on a proposed bond issue of \$475,000 for high school site, and \$75,000 for grammar school site. Carried 3 to 1.

Hillsborough is about to commence seven miles of street paving. Something of a permanent nature is determined upon.

Woodland High School District has started proceedings to submit the question of a \$60,000 bond issue for a new high school.

Crescent City will open bids for 800 feet of 2½ in. fire hose and a hose cart on April 3rd. Also, for a rock crusher and appurtenances.

Burlingame has awarded a contract to the Esterly Construction Company for putting down 5 blocks of concrete curbs and sidewalks.

Suisun proposed to purchase 500 feet of fire hose recently. About half of it failed to stand the severe test imposed by Superintendent Wilson.

Vallejo is about to commence construction of a new high school. The plans of Engineer Noyes for the construction of a municipal wharf, have been approved.

San Mateo is about to expend \$200,000 on the improvement of its streets, sidewalks, and parks. The board is about to start the sewer and fire department improvements recently voted.

Madera has awarded the contract for constructing its municipal water system to Frederick C. Roberts Co., notwithstanding the bid of this company was about \$3000 higher than the next lowest bid. The plant will cost \$50,000 and will have the latest pumping, electrical and gas engine units.

## TRADE NOTES

The bonds for the State of California voted for at the last general election for India Basin Act, San Diego Seawall Act, San Francisco Harbor Improvement Act, State Highway Act, amounting in all to \$59,500,000.00 have been awarded to A. Carlisle & Co. of San Francisco to execute. They will be all steel engraved with special appropriate vignettes. This is one of the largest bond jobs ever let on the Pacific Coast.

## LIST OF RESPONSIBLE FIRMS TO BE CALLED ON TO BID FOR PUBLIC WORK OR SUPPLIES

### WRITE FOR CATALOGS

This list is arranged as a guide for the accommodation of city officials where advertising for bids is not necessary.

- Accountant**  
William Dolge, C. P. A., 255 California St., S.F.
- Architects**  
W. H. Weeks, 251 Kearney St., S. F.
- Asphalt Machinery**  
J. I. Case Thresh'g Mch Co. 616 Myrtle St. O'kl'nd  
A. L. Young M'chy Co. 26-28 Fremont St., S. F.
- Arch. Terra Cotta**  
Gladding, McBean & Co., Crocker Bldg, S.F.  
Steiger Terra Cotta & Pottery Wks, 729 Mills Bldg., S. F.
- Automobile Public Service Wagons**  
The Thomas B. Jeffery Co., 117-125 Valencia St., S. F.  
Reliance Auto. Co., 342 Van Ness Ave., S. F.  
American La France Fire Eng. Co., 660 Mission St., S. F.
- Bitulithic Pavement**  
Warren Brothers Company, Los Angeles, Cal.
- Blue Prints**  
So. Cal. Blue Print & Supply Co., 800 L. A. Trust Bldg., Los Angeles.
- Bridge Builders**  
E. T. Thurston, Jr., Wells, Fargo Bldg., S. F.
- Concrete Construction**  
Esterly Con. Co., Inc., 717 Market St., S. F.
- Concrete Mixers**  
California Hydraulic Eng. & Supply Co., S. F. and Los Angeles
- Constructing Engineers**  
Fred'k C. Roberts & Co., 221 Sheldon Bldg, S.F.  
Cal. Hydraulic Engineering & Supply Co., San Francisco and Los Angeles
- Consulting Engineers**  
Sloan & Robson, Nevada Bank Bldg., S. F.  
E. T. Thurston, Jr., Wells Fargo Bldg., S. F.
- Culverts**  
Cal. Corrugated Culvert Co., Los Angeles and W. Berkeley
- Dump Carts and Wagons**  
J. I. Case Thresh'g Mch Co. 616 Myrtle St. O'kl'nd  
A. L. Young M'chy Co., 26-28 Fremont St., S.F.  
Watson Wagon Co., Canastota, N. Y.
- Electrical Plants & Machinery**  
A. L. Young M'chy Co., Fremont St., S. F.
- Engravers and Bond Printers**  
A. Carlisle & Co., 251 Bush St., S. F.  
Schmidt Lith. Co., Second & Bryant Sts., S.F.  
Sierra Art Eng. Co., Front & Com. Sts., S. F.
- Fire Engines**  
Gorham Eng & Fire App Co., 48 Fremont St S. F.  
Squires & Byrne Co., 565-567 Mission St., S.F.
- Fire Hose**  
Gorham Eng & Fire App Co., 48 Fremont St S. F.  
New York Belting & Packing Co., 129-131 First St., S. F.  
The Gutta Percha & Rubber Mfg. Co., 34 Fremont St., S. F.
- Gasoline Engines**  
Cal. Hydraulic Eng. & Supply Co. S. F. and Los Angeles
- Municipal Accountant**  
William Dolge, C. P. A., 255 California St., S.F.
- Municipal Printers**  
A. Carlisle & Co., 251-253 Bush St., S. F.
- Municipal Engineers**  
Fredk. C. Roberts & Co., 461 Market St., S.F.  
Sloan & Robson, Nevada Bank Bldg, S. F.
- Municipal Lighting Plants**  
Fredk. C. Roberts & Co., 461 Market St. S.F.
- Municipal Water Works**  
Fredk. C. Roberts & Co., 461 Market St., S.F.
- Pavement Materials**  
Barber Asphalt Paving Co., S.F. and L. A.  
Warren Brothers Company, Los Angeles, Cal.
- Playground Apparatus**  
A. L. Young Machinery Co., S. F.
- Pumping Machinery & Supplies**  
California Hydraulic Eng. & Supply Co., San Francisco & Los Angeles
- Riggers**  
C. A. Blume Con. Co., 185 Stevenson St., S.F.
- Road Machinery**  
J. I. Case Threshing Mch. Co., 616 Myrtle St., Oakland, Cal.  
The Good Roads Mach'y Co., Ft. Wayne, Ind.  
Henshaw, Bulkeley & Co., Fremont St., S. F.  
A. L. Young M'chy Co., Fremont St., S. F.  
Petrolithic Co., 345 P. E. Bldg., L. A.
- Rubber Goods**  
Squires & Byrne Co., 565-567 Mission St., S.F.
- Sanitary Wiping Rags**  
The Raychester Co., 1448 Folsom St., S. F.
- Scrapers**  
J. I. Case Thresh'g Mch Co. 616 Myrtle St. O'kl'nd  
A. L. Young M'chy Co., Fremont St., S. F.  
Petrolithic Co., 345 P. E. Bldg., L. A.
- Sewer (Concrete)**  
Esterly Con. Co., Inc., 717 Market St., S.F.
- Sewer Pipe and Terra Cotta**  
Gladding, McBean & Co., Crocker B'ldg, S.F.  
Steiger Terra Cotta Co., Mills B'ldg., S. F.
- Sewer Systems**  
Sloan & Robson, Nevada Bank Bldg., S. F.
- Sidewalks (Cement)**  
Esterly Con. Co., Inc., 717 Market St., S. F.  
Steel Protected Concrete Co., Phila., Pa.
- Street Signs**  
A. L. Young Mch. Co., S. F.
- Street Sweepers**  
A. L. Young M'chy Co., Fremont St., S. F.
- Structural Steel Erectors**  
C. A. Blume Con. Co., 185 Stevenson St., S.F.
- Water Works Equipment**  
California Hydraulic Eng. & Supply Co., San Francisco and Los Angeles



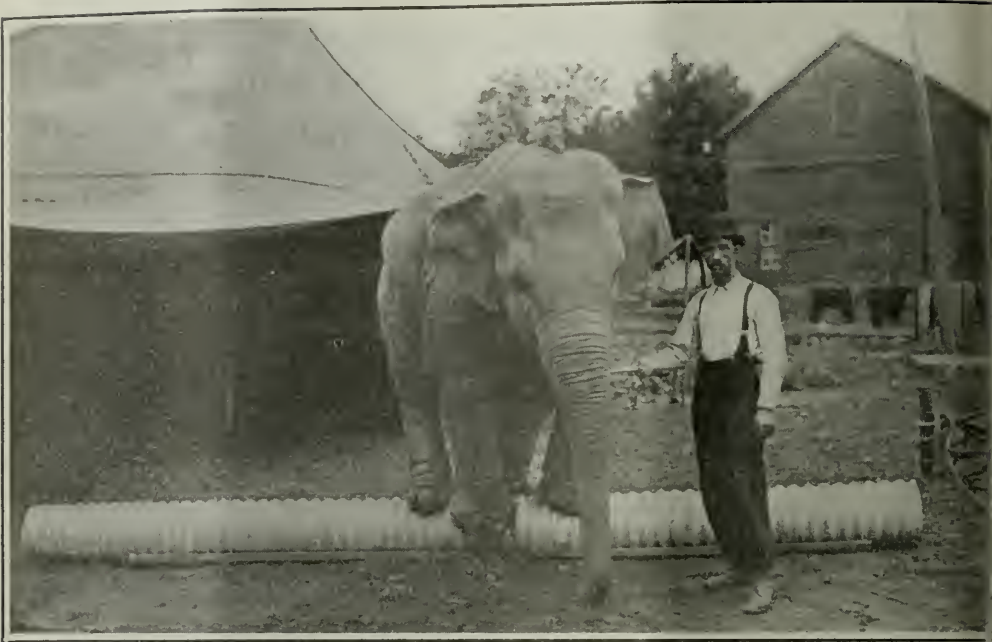

**Q**The wonderful intelligence of the elephant is no more clearly shown than his careful selection of a secure footing. He will not trust his great weight on weak structures.

## American Ingot Iron Culverts

have the the strength to carry the greatest loads.

The corrugations make them 29 times as strong as plain pipe of the same weight material. They are the lightest and most easily handled. They will last a lifetime because

They are made of American Ingot Iron 99.94% Pure.

"The purer the iron, the greater its resistance to corrosion."

Let Us Demonstrate These Facts to You

---

**California Corrugated Culvert Company**  
 Los Angeles, Cal. West Berkeley, Cal.

# International Municipal Congress and Exposition

Chicago, Ill., U. S. A., September 18 to 30, 1911

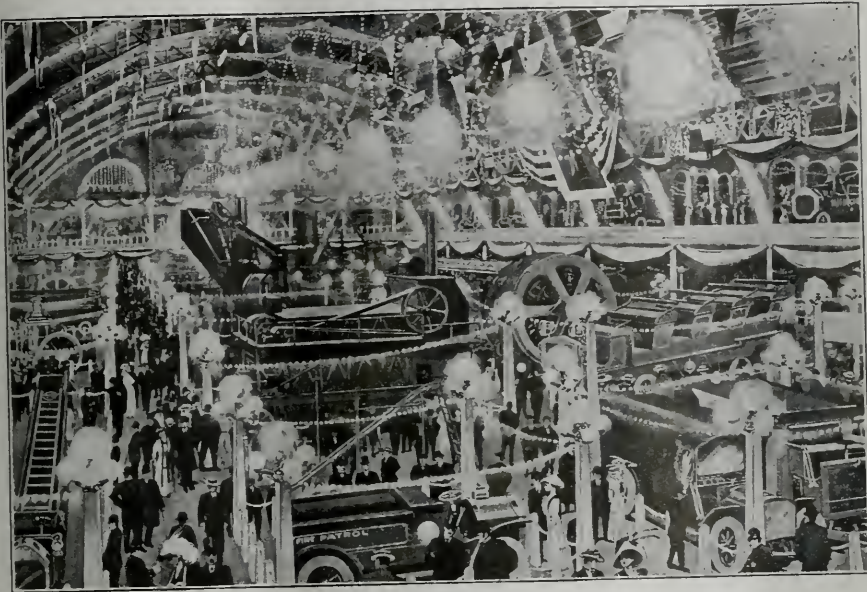

**T**HE CONGRESS will be participated in by Municipal Officials and duly appointed delegates from all of the principal cities of America and Foreign Lands, together with the members of National and International organized bodies concerned in any particular branch of civic work or in clean, economic municipal government as a whole. The world's brightest as well as practical minds will deliver to the Congress papers bearing on that special line of municipal undertaking which they have made their respective studies for a lifetime.

**T**HE EXPOSITION will comprise not only municipal exhibits of every variety, but also the works of the great inventors and manufacturers of the world, who are manufacturing and providing municipal supplies for the universe.

### Local Forces Participating

The City of Chicago	Civic Federation of Chicago
Chicago Association of Commerce	City Club of Chicago
Citizen's Association of Chicago	United Charities of Chicago
Industrial Club of Chicago	Rotary Club of Chicago

### Full Information Upon Application to Either of the Undersigned

JOHN M. EWEN, Chairman	CURT. M. TREAT, Secretary
JOHN MAC VICAR, Commissioner General of Congress	
EDWARD H. ALLEN, General Manager of Exposition	
1107 Great Northern Building	CHICAGO, ILLINOIS

Or to their Pacific Coast Representatives:  
League of California Municipalities, Pacific Building, San Francisco, Cal.

# Worswick Street Paving Company



## GENERAL CONTRACTOR

Sheet Asphalt, Macadam,  
Asphalt Concrete, Cement  
Concrete Constructions

Dealer in  
Asphalt, Crushed Rock  
Gravel and Sand



Main Office, Rooms 5, 8, 9, Union National Bank Building

Phone Main 1434

Cable Address "Worswick"  
Western Union Universal Code

Fresno, California



The Products of  
**The Barber Asphalt Paving Co.**

**BEST BY TEST**

---

**Genasco Ready Roofing**

Both smooth and graveled surface adapted for use on all classes of buildings.

**Genasco Roof Coating**

The best roof coating ever offered.

**Genasco Positive Seal Paint**

Makes all concrete or stone walls damp-proof.

---

**Iroquois Rollers**

Iroquois Macadam and Asphalt Tandem Rollers and all road making and paving machinery and tools.

---

**THE BARBER ASPHALT PAVING  
COMPANY**

**PHILADELPHIA**

**New York, Chicago, San Francisco, Los Angeles**

## California Hydraulic Engineering & Supply Co.

### Constructing Engineers

Complete Pumping Plants for City, Fire and Irrigating Systems  
Gasoline Engines, Centrifugal and Deep Well Pumps  
Motors, Concrete Mixers and Supplies

70 Fremont Street  
San Francisco

341 South Los Angeles Street  
Los Angeles

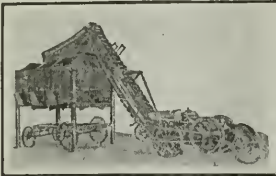

### BUILDING GOOD ROADS

is work that counts. To do this work economically you need a **Fort Wayne Mounted Rock Crusher** with Elevator, Screen and Portable Bin.

**Efficient, Serviceable and Convenient**  
Built in several sizes

Send for catalog of Crushers, Dump Wagons, Road Graders, Steam Rollers, Sprinklers, Sweepers—Everything for Building Roads and Streets.

**The GOOD ROADS MACHINERY COMPANY, Fort Wayne, Ind.**  
Coast Representative, A. L. Young Machinery Co., San Francisco, Cal.

## A. CARLISLE & CO.

### Stationers, Printers and Bookbinders

We specialize in Bonds, Steel Die, Lithographed or Printed, for Municipalities or Counties, and the Books and Forms required by all Municipal Officers.

**251-253 Bush Street**

**San Francisco, Cal.**

Men in Public Service should assist in the redemption of

## LIQUOR USERS

The man who keeps his nerve propped with liquor, who feels his prestige slipping from him and his business equilibrium gone, knows that he soon will be relegated to the ranks of the "has beens," and unless able to retrieve himself from the clutches of alcohol, there will soon be written over his dead career this epitaph: "He Might Have Been." In three days

**THE NEAL TREATMENT, without hypodermic injections,**

Will cure the drink habit perfectly by a harmless process and with most pleasing after-effect. Positively no injury can result. Institutes in all the larger commercial centers of the United States and Canada. Business confidential. Write or call for full information and reference.

### THE NEAL INSTITUTE

1409 Sutter St.

Phones Franklin 1098; Home S2674

San Francisco, Cal.

# FREDK. C. ROBERTS & CO.

(INCORPORATED)

*Mechanical and Electrical Engineers*

MUNICIPAL WATER WORKS  
MUNICIPAL LIGHTING PLANTS  
POWER PLANT EQUIPMENTS

461 Market Street

San Francisco, Cal.

# FIRE HOSE

THE GUTTA PERCHA & RUBBER MFG. CO.

34 Fremont St., SAN FRANCISCO, CAL.

**E. T. THURSTON, JR.**  
M. Am. Soc. C. E.

*Consulting Engineer*

713 Mechanics' Institute

Phones Sutter 1683 and C 2895 SAN FRANCISCO

*Specialties*

Design and Supervision of Buildings, Bridges,  
Sewers, Water Works, Highways, etc.

*Concrete Bridges*

Exclusive rights under patents of National  
Bridge Company, the largest in the world.

Estimates furnished free of charge.

# C. A. BLUME CONSTRUCTION CO.

Members of Builders Exchange

Structural Steel Erectors

Riggers

Phone Douglas 324  
185 STEVENSON STREET

SAN FRANCISCO

# ESTERLY CONSTRUCTION CO., Inc.

CONCRETE CONTRACTORS

Buildings, Bridges, Sidewalks, Walls, Floors, Foundations

Room 605, 717 Market St., San Francisco

2136 Center St., Berkeley



# M. Greenberg's Sons,

225 and 227 BEALE STREET

Phone Kearny 276 San Francisco

FIRE HYDRANTS, COUPLINGS, ETC.

Manufacturers of Engineers' Findings, Plumbers', Steamship, Brewers' & Winery Brass Goods  
Brass and phosphor bronze castings; brass and iron work of every description made and repaired



# Henshaw, Bulkley & Co.

## ROAD MACHINERY

### A SPECIALTY

19-21 Fremont Street  
San Francisco

262-264 So. Los Angeles St.  
Los Angeles

TERRA COTTA, PRESSED BRICK, PIPE,  
FIRE PROOFING, ROOFING TILE,  
FLUE LININGS, FIRE TILE,  
LAUNDRY TRAYS,  
ETC.

**GLADDING, McBEAN & CO.**

WORKS  
LINCOLN, CAL.

--- OFFICE ---

311-317 CROCKER BLDG., SAN FRANCISCO.

## Steiger Terra Cotta and Pottery Works

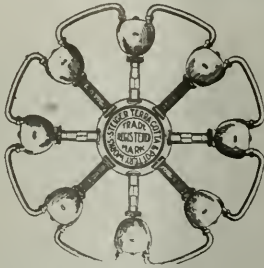

MAIN OFFICE AND YARDS:

City Yard, 18th and Division Streets

Main Office: 729 Mills Building

Phone Douglas 3010

SAN FRANCISCO, CAL.

Factory, South San Francisco  
San Mateo County

**Knox**  
BEST BY TEST

Fire Apparatus  
Police Patrols  
Ambulances



REPRESENTED BY

**RELIANCE AUTOMOBILE CO.**

342-352 Van Ness Ave.

SAN FRANCISCO

# Wainwright Galvanized Steel Corner Bar

For Protecting Edges of Concrete Curbs, Steps, Columns, Etc.

The only effective **Concrete Edge Protector** offered to the contracting public

WAINWRIGHT PATENTS—March 9, 1897. November 22, 1898. May 5, 1903.  
March 26, 1907. August 29, 1907. August 2, 1910.

This bar has been in public use for more than ten years as the main feature of the



## WAINWRIGHT STEEL-BOUND CONCRETE CURB

THE BEST IN THE WORLD

OVER THREE MILLION FEET

In use in more than three hundred cities in the United States

Absolutely Non-Breakable  
Cheaper Than Granite

Handsome than Granite and much stronger.  
Continuous in Construction, hence Never Out of Line.  
GALVANIZED STEEL CORNER BAR Prevents Chipping or Breaking on Edges.

This Curb is Mechanically Perfect and Unequaled for Curved Corners.

THIS CURB WILL STAND HARDER USE AND LAST TEN TIMES AS LONG AS PLAIN CONCRETE CURBING.

Contractors can make money by laying this curb.

City Engineers can save money by specifying it.

Architects are invited to read pages 242 and 243 "Sweet's Index."

Metal Parts for Sale. Send for Copyrighted Booklet No. 19.

REAL ESTATE TRUST BUILDING  
PHILADELPHIA, PA.

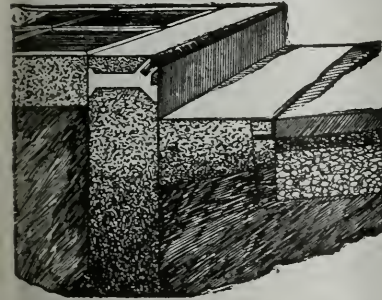

STEEL PROTECTED CONCRETE CO.

Insulated Wires and Cables

Wire Cloth and Netting

## John A. Roebling's Sons Co.

S. V. MOONEY, Manager  
MANUFACTURERS OF

Iron, Steel and Copper Wire Rope and Wire  
of every description

Phones, Kearny 2426; Home J 1220

624-646 Folsom Street

SAN FRANCISCO

Works at Trenton, N. J., and Roebling, N. J.

## SQUIRES & BYRNE CO.

565-567 Mission St., San Francisco

Dealers in all kinds of

### Double Jacket Fire Hose

for department uses. Underwriters Linen Hose, Fire Hose Carts and Jumpers. Extinguishers and equipments for Fire Departments, also a full line of mechanical rubber goods of every description. Write for discounts and prices.

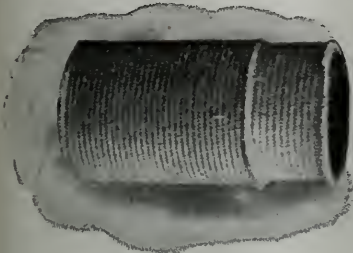

**WILLIAM DOLGE***Certified Public Accountant --:-- Municipal Accountant*

TELEPHONE DOUGLAS 5173

255 California Street

San Francisco, Cal.

**WM. H. WEEKS, Architect**PUBLIC BUILDINGS A SPECIALTY

251 Kearney Street

San Francisco

**SLOAN & ROBSON, Engineers**Reports, Designs, Estimates and Supervision of Municipal  
Light, Water and Sewer Systems

Telephone Kearney 4646

Nevada Bank Building, SAN FRANCISCO

**Gorham Engineering & Fire Apparatus  
Company***Fire Department Supplies of Every Description*

48 Fremont Street

San Francisco, Cal.

Branch Stores, Los Angeles, Cal.; Seattle, Wash.

**THE CLARA BARTON****Sanitary Wiping Rags**

The Clara Barton Brand of Wiping Rags  
are Guaranteed to be thoroughly sterilized  
and disinfected. Telephone Market 2286

**The Raychester Co., Inc.**

1448-1460 FOLSOM ST., SAN FRANCISCO





THE ARLINGTON

## SANTA BARBARA, THE MISSION CITY BY THE SEA.

*One Wonder*

On the  
ROAD OF A THOUSAND WONDERS

A trip to California is incomplete unless you visit this historical city with its wonderful effects of mountain and sea, its beautiful homes, its wonder garden of flowers and trees, its palatial hotels and the Always Interesting OLD MISSION.

## SOUTHERN PACIFIC

**San Francisco Offices:—**

Flood Building.  
Palace Hotel.  
Market Street Ferry Building.  
Third and Townsend Street Depot.

**Los Angeles Offices:—**

600 South Spring Street.  
Arcade Station.

# MUNICIPAL AND CONTRACTORS' MACHINERY

...FOR...

## GOOD ROADS AND STREETS

Street Signs  
National Road Machines  
Fort Wayne Road Machines  
Indiana Road Machines  
National Elevating Graders  
Elevators—Portable Bunkers  
Shares or Cutting Edges for all types of Road Machines  
Rock Crushers, Jaw and Gyratory Type, mounted and unmounted  
Screens  
Steam Road Rollers  
Horse Rollers  
Scarifiers  
Harrows for oiled roads  
Wheeled and Drag Scrapers  
Fresno Scrapers  
Reversible Road Plows  
Street Sprinklers  
Sprinkling Attachments  
Street Sweepers  
Fibre for Street Sweepers  
Watson Dump Wagons  
Asphalt Machinery  
Kettles—Hand Rollers—Tampers  
Concrete Mixers  
Hoisting Engines  
Playground Apparatus  
Culvert Pipe

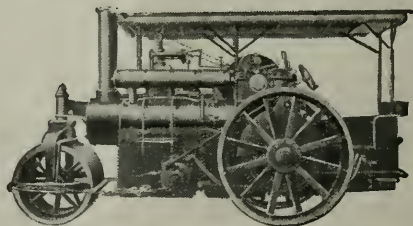

Write us for Catalogues and Estimates

## A. L. Young Machinery Co.

26-28 Fremont Street

San Francisco

California

# PACIFIC MUNICIPALITIES

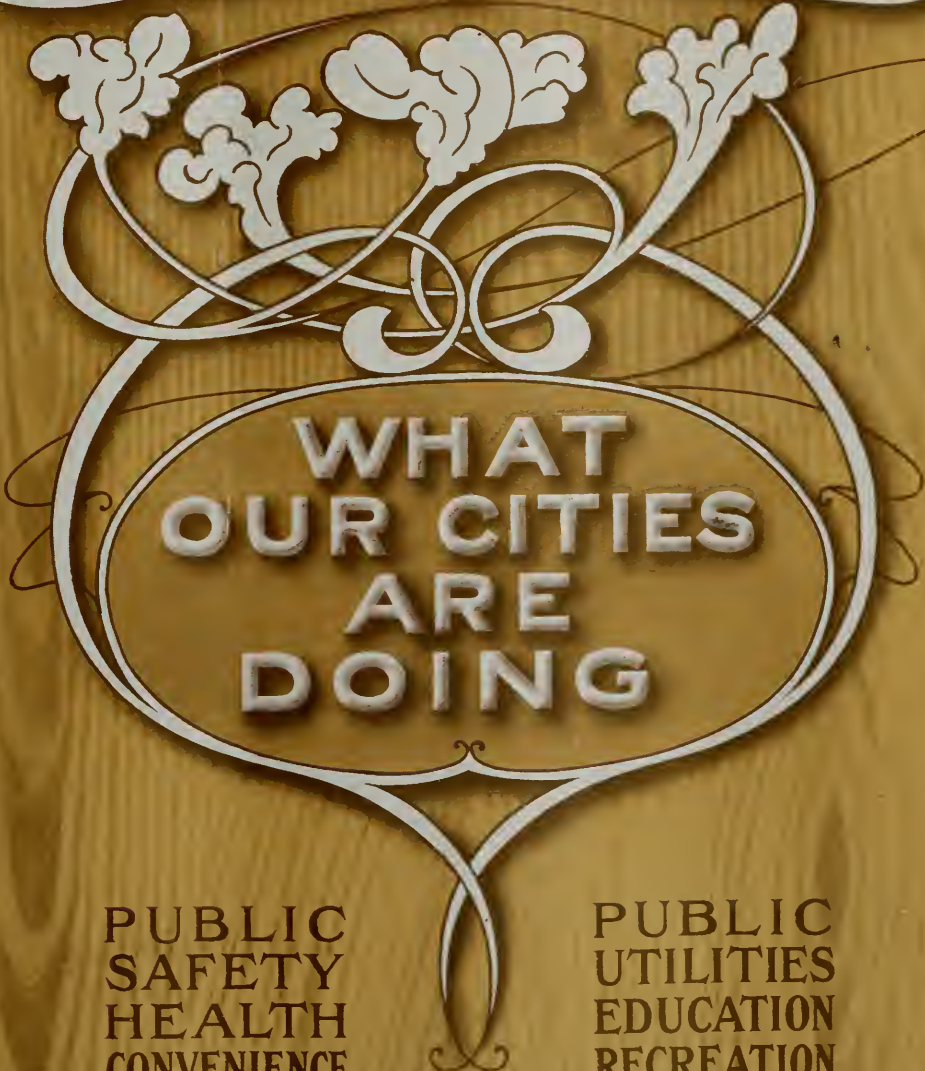

WHAT  
OUR CITIES  
ARE  
DOING

PUBLIC  
SAFETY  
HEALTH  
CONVENIENCE

PUBLIC  
UTILITIES  
EDUCATION  
RECREATION

PUBLISHED MONTHLY





When a man feels the necessity of being in two places at the same time he goes to the nearest telephone and sends his voice. It is not exactly the same thing, but when a man talks hundreds of miles in opposite directions from the same Bell Telephone, it is about as good. In the daily use of the telephone a man travels all over town by wire in a few minutes. It is just as easy to travel all over the state and other states by means of the universal Long Distance Service of the Bell System.



## The Pacific Telephone & Tel. Co.

*Every Bell Telephone is the Center of the System*



**SILENT**

**LUXURIOUS**

**3 MODELS**

THE NEW  
**Rambler**

Touring Cars, Motor Fire Trucks, Chemical, Hose,  
Police Patrol and Ambulances a Specialty.

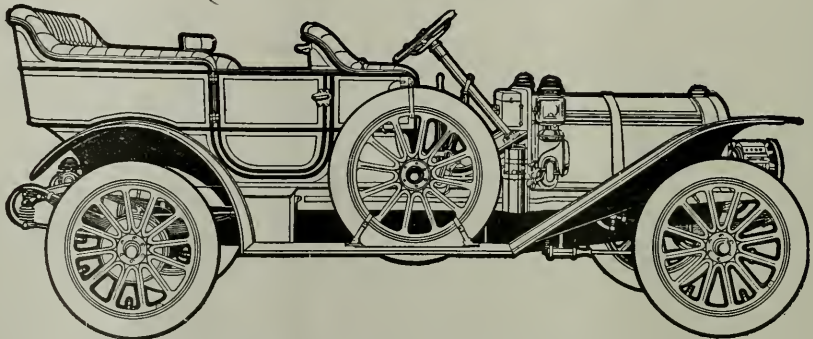

**The Thomas B. Jeffery Co.**

117-125 Valencia St.

WRITE FOR INFORMATION.

San Francisco

# “THE ROAD IS THE THING”

When built by the CASE Power-steered Road Roller

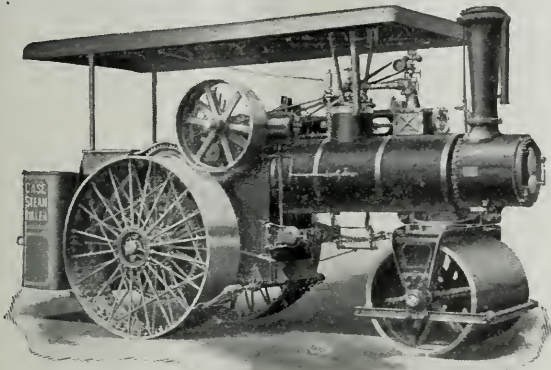

Power steering saves time over hand steering. Time saved is profit. The time saved in using a Case Roller and the extra work accomplished give increased profits to you, Mr. Contractor.

Write for Catalog on Road Roller, Road Machinery and Troy Dump Wagons and Boxes: for Contractors' General Purpose Engine and Municipal Catalog M. Address Road Machinery Dept.

Price, Simple Cylinder, \$2,200

6% discount for cash

J. I. CASE THRESHING MACHINE COMPANY, Inc. RACINE, WIS., U. S. A.

BRANCH OFFICE, 616 MYRTLE ST., OAKLAND, CAL.

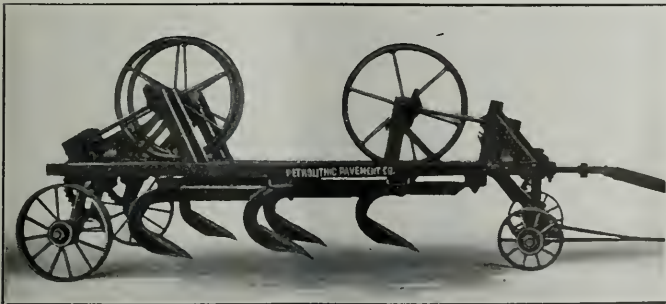

Let us tell you about the new

Petrolithic Gang Road Rooter and Scarifier

THE PETROLITHIC CO.

345 P. E. Bldg.  
Los Angeles

Wherever good Contractors are,

there the Watson dump wagon is known. It's the most used dumping wagon in America, both by contractors and municipalities.

Only one single type of wagon is made in our big factory. All our time and money is devoted to doing one thing, and doing it well. Our printed matter is as high grade as the wagon. Ask for it.

WATSON WAGON COMPANY, Canastota, New York

The First Builders of Bottom Dumping Wagons



California Agencies: San Francisco, A. L. Young Machinery Co. 26-28 Fremont St.; Los Angeles, L. M. Davenport Co.

# “BITULITHIC”

## The Ideal Boulevard Pavement

### “BEST BY EVERY TEST”

☞ BITULITHIC has been adopted as the standard pavement in more than 200 cities, all of which give unqualified praise for BITULITHIC in the earliest as well as the latest cities. More than 15,000,000 square yards BITULITHIC PAVEMENT laid and contracted for in ten years, equal to over 850 miles of 30-foot roadway, shows the rapid increase of yardage and success of the BITULITHIC PAVEMENT.

☞ The following is one of many endorsements that shows that BITULITHIC is the most essential factor in real estate development:

315-316 Dickson Building,  
Norfolk, Virginia, May 7, 1910

Mr. George O. Tenney, Pres.,  
Atlantic Bituliphic Co., Richmond, Va.

Dear Sir:—

As per your request we are offering our opinion of the Bitulithic Pavement and its influence on the value of real estate.

We believe, from comparison with various kinds of paving, that it is the most durable and satisfactory, when constructed in a high grade manner. The Seventh Ward of our city has recently completed eleven miles of Bitulithic; a large expenditure, but justified by the increased tax return from the real estate. Real estate in this ward has increased twenty-five per cent. in value.

Very truly yours,

COLLINS & VAN DENBERGH, INC.

(Signed) Paul T. Collins, President.

☞ BITULITHIC affords a superior foothold for horses in either wet or dry weather and is a sanitary, non-skidding resilient street pavement.

☞ BITULITHIC beautifies the city and enhances the value of property more than any other form of pavement.

— Write today for explanatory booklets to —

## WARREN BROTHERS COMPANY

59 Temple Place, Boston, Mass. 616 Laughlin Bldg., Los Angeles

— (REGISTERED IN THE U. S. PATENT OFFICE) —

“Bitulithic” “Warrenite” “Bitustone” “Bitrock” “Puritan” “Rockphalt”  
“Bituminous Macadam”



NOTE—Every city official in California reads Pacific Municipalities.

# Pacific Municipalities

OFFICIAL ORGAN OF THE LEAGUE OF CALIFORNIA MUNICIPALITIES

Entered at Post Office, Santa Clara, Cal., as Second-Class Matter

---

VOL. XXIV

TWELFTH YEAR

No. 3

---

EDITORS - - - H. A. MASON AND WM. J. LOCKE  
EDITORIAL OFFICE - NINTH FLOOR, PACIFIC BLD'G, SAN FRANCISCO  
PUBLICATION OFFICE, - - - SANTA CLARA, CALIFORNIA

---

## CONTENTS FOR APRIL, 1911

---

New Laws Affecting Municipalities	89
Good Roads	<i>Paul Beer</i> 92
International Municipal Congress and Exposition	96
Proceedings of the Convention of the League of California Municipalities	97
Sanitation of Water Supplies and San Diego's Water System	<i>Emory E. Smith</i> 97
Need Independent Fire Alarm System	102
The Effect of Motor Traffic on Oil Macadam	<i>S. J. Van Ornum</i> 107
Sebastopol's Water System	109
Editorial	110
Trade Notes	111
Questions and Answers	112
What the Cities Are Doing	119

---

Published Monthly. Yearly Subscription, \$2.00 in Advance. Single Copies, 25 Cents

ADVERTISING RATES ON APPLICATION

Address all Communications to "PACIFIC MUNICIPALITIES" Pacific Building  
San Francisco, California

# LEAGUE OF CALIFORNIA MUNICIPALITIES

Organized 1897

## — OFFICERS —

President	- - -	(Mayor of Berkeley)	- - -	BEVERLY L. HODGHEAD	
First Vice-President	- - -	(Councilman of San Diego)	- - -	A. E. DODSON	
Second Vice-President	- - -	(Mayor of Santa Cruz)	- - -	T. W. DRULLARD	
Secretary	-	H. A. MASON	Ass't Secretary	-	WM. J. LOCKE

## STANDING COMMITTEES

EXECUTIVE—Beverly L. Hodghead; H. A. Mason; S. C. Evans, Mayor of Riverside; Percy V. Long, City Attorney San Francisco; W. P. Butcher, City Attorney Santa Barbara.

LEGISLATIVE—W. F. Hyde, Palo Alto; J. O. Walsh, San Francisco; J. H. Strait, Redlands; F. H. Allbright, Red Bluff; B. L. Barney, Hanford.

JUDICIARY—C. N. Kirkbride, San Mateo; P. G. Sheehy, Watsonville; Stephen G. Long, Long Beach; R. E. Rhodes, Madera; Wm. J. Carr, Pasadena.

ENGINEERING—Chris. P. Jensen, Fresno; C. H. Pieper, San Jose; A. P. Noyes, Vallejo; R. C. Tunnelly, Stockton; O. E. Stewart, Anaheim.

Secretary's Office and Headquarters of the League, - Pacific Building, San Francisco

## INFORMATION BUREAU

The League of California Municipalities maintains, in connection with the Secretary's Office, an Information Bureau where the officials of the municipalities belonging to the League can secure information on all subjects relating to municipal affairs.

## MEMBERSHIP

Alameda	Lakeport	Riverside
Albany	Lemoore	Sacramento
Alhambra	Lindsay	San Bernardino
Anaheim	Livermore	San Buenaventura
Antioch	Lodi	San Diego
Azusa	Lompoc	San Francisco
Bakersfield	Long Beach	San Jose
Benicia	Los Banos	San Leandro
Berkeley	Los Gatos	San Luis Obispo
Biggs	Loyalton	San Mateo
Bishop	Madera	Santa Ana
Black Diamond	Martinez	Santa Barbara
Burlingame	Merced	Santa Clara
Calistoga	Mill Valley	Santa Cruz
Chico	Modesto	Santa Maria
Coalinga	Monterey	Santa Monica
Colton	Mountain View	Santa Paula
Colusa	Napa	Santa Rosa
Compton	National City	Sebastopol
Coronado	Newman	Selma
Corona	Newport Beach	Sierra Madre
Covina	Oakland	Sisson
Crescent City	Oceanside	Sonoma
East San Jose	Orange	Sonora
Elsinore	Oroville	South Pasadena
Emeryville	Oxnard	South San Francisco
Escondido	Pacific Grove	St. Helena
Etna	Palo Alto	Stockton
Eureka	Pasadena	Suisun City
Fairfield	Petaluma	Susanville
Ferndale	Piedmont	Tehachapi
Fort Jones	Pinole	Tracy
Fowler	Placerville	Tulare
Fresno	Pleasanton	Vacaville
Gilroy	Point Arena	Vallejo
Glendale	Pomona	Visalia
Hanford	Red Bluff	Watsonville
Hayward	Redding	Whittier
Hercules	Redlands	Willits
Hermosa Beach	Redondo Beach	Winters
Hillsborough	Redwood City	Woodland
Huntington Park	Richmond	Yreka
Imperial	Rio Vista	
Jackson		

Every city belonging to the League of California Municipalities is entitled to a free copy of this magazine every month for each of its officials; if not received kindly notify the Secretary. See that your City is in the above list.

# PACIFIC MUNICIPALITIES

▲ Journal for Progressive Cities

Vol. XXIV

APRIL 29, 1911

No. 3

## NEW LAWS AFFECTING MUNICIPALITIES

### SENATE BILLS

No. 26. Approved February 8.

An act changing the classification of cities and providing that hereafter those having a population under 6000 shall constitute the cities of the sixth class, and those having a population between 6000 and 20,000 shall constitute cities of the fifth class.

No. 44. Approved.

An act providing that if a new municipality was incorporated within sixty days prior to a regular municipal election, and if for any reason such election was not held, the officers elected at the time of incorporation should hold until the regular election of 1912.

No. 110. Approved February 13.

Authorizing the creation of sewer districts within municipalities and the issuance of bonds for such districts upon a  $\frac{2}{3}$  vote of the inhabitants of such districts.

No. 181. An act requiring the state controller to publish annual reports of the financial transactions of the counties and municipalities. Officials are compelled to make the required reports, otherwise the controller may appoint an accountant to investigate the accounts of the delinquent city or county.

No. 256. Approved February 14.

An act providing that if the town trustees fail to fill a vacant elective office within thirty days after the vacancy occurs, they must call a special election for such purpose.

No. 359. Approved April 10.

An act adding two new sections to the Municipal Corporations Bill, numbered 752 A and 852 B, providing that cities of the 5th and 6th class may adopt the commission form of government.

No. 360. Approved March 14.

An act providing for the initiative, referendum and recall for fifth and sixth class cities.



- No. 466. To Governor.  
An act authorizing a municipality to acquire, construct, own, operate or lease any public utility, such as water, light, heat, power or transportation.
- No. 467. Approved March 1.  
An act validating municipal bonds.
- No. 552. Approved April 10.  
An act authorizing municipalities to levy and collect a tax of 15 cents on each \$100, for parks, music and advertising, in addition to all other taxes. The act is not effective however, until approved by a vote of the electors.
- No. 792. Approved March 21.  
An act validating municipal bonds.
- No. 896. Approved April 3.  
An amendment to Section one, fourteen and fifteen of the "street lighting act" approved March 21, 1905.
- No. 952. Approved April 10.  
An amendment to the Vrooman Act providing that all private contracts shall be made in duplicate and a copy given to the property owner.
- No. 987. Approved April 5.  
An act repealing the sidewalk act of 1910.
- No. 1018. To Governor March 24.  
An act amending the improvement act of April 21, 1909, relating to cases where damages would result to private property, providing for the proof, by affidavits, of the publishing and posting of notices.
- No. 1019. Approved April 10.  
An act providing for the proof by affidavit of the publication and posting of notices in the "Change of Grade Act" of April 21, 1909.
- No. 1030. Approved April 10.  
An act amending act of 1897 allowing city to sell excess water.
- No. 1124. Approved April 10.  
An act amending Section 33 of the street opening act of 1903, by defining various terms used in the act.
- No. 1132. Approved April 10.  
An act amending the Annexation Act of 1889, and providing that new territory may be annexed with the understanding that such new territory will share in the expense of any indebtedness previously incurred for improvements.
- No. 1133. An act amending the Consolidation Act of 1909, and providing that municipalities may be consolidated with the understanding that they will share existing indebtedness.
- No. 1150. An act authorizing a city or town which has annexed new territory, to adjust, settle and pay all lawful claims against said newly annexed territory.
- No. 1173. Approved April 21.  
An act providing for work on streets and highways that form the boundaries between municipalities or the boundary between a municipality and the county.

- No. 1211. An act amending the street improvement bond act of the Vrooman Act by making the bonds conclusive evidence of their validity.
- No. 1217. Approved April 5.  
An act amending Sections 2, 7, 13, 35 and 53 of the Vrooman Act by incorporating therein certain provisions, of the act framed by the committee of City Attorneys of the League of California Municipalities.
- No. 1256. An act authorizing certain cities to collect taxes for harbor improvements, and issue bonds therefor.

### ASSEMBLY BILLS

- No. 293. Approved March 24  
An act changing the classification of cities as follows:  
Cities of more than 400,000 1st class.  
Cities of more than 250,000 1½ class.  
Cities from 100,000 to 250,000 2nd class.  
Cities from 35000 to 100,000 2½ class.  
Cities from 23000 to 35000 3rd class.  
Cities from 20,000 to 23,000 4th class.  
Cities from 6000 to 20,000 5th class.  
Cities from 6000 or less 6th class.
- No. 508. Approved March 9.  
An act making the office of Marshal appointive by the trustees, in cities of the sixth class.
- No. 654. Approved March 1.  
An act authorizing a municipality using the word "town" in its official name to change such word to "city."
- No. 807. Approved March 1.  
An act amending Section 755 of the Municipal Corporations Bill, and providing that members of the board of trustees in cities of the fifth class may be paid a salary after such proposition has been approved by the electors.
- No. 1006. Approved March 7.  
An act authorizing municipal corporations to permit other municipal corporations to construct and maintain sewers, water mains and other conduits therein, also to share in the expense and benefits of the same.
- No. 1008. To Governor March 23.  
An act validating municipal corporations.
- No. 1099. To Governor March 23.  
An act to validate the annexation of new territory to municipal corporations.
- No. 1067. Approved March 20.  
An act to enable cities of the sixth class to elect officers.
- No. 1122. Approved April 12.  
An act amending Section 14 the street opening act of March 24, 1903, and providing that if proceedings be abandoned or action dismissed, no attorney's fees shall be awarded defendants.
- No. 1150. Approved April 12.  
An act authorizing a municipality to lay steam pipes in streets for transmitting steam for heating purposes.

No. 1177. Approved April 14.

An act to provide for the division of municipalities into sewer districts and the acquisition, construction and maintenance of sewers therein and providing a system of district sewer bonds to pay cost of same.

No. 1339. Approved April 7.

A substitution for the Vrooinon Act, framed by the Committee of city attorneys from the League of California Municipalities. The proceedings are simplified, shortened and made more clear.

No. 1526. To Governor, March 23.

Authorizing cities of the 5th class to create water districts and issue bonds therefor.

No. 1536. An act amending Section 862 of the Municipal Corporation Bill, enlarging the powers of trustees of cities of the sixth class.



## GOOD ROADS

BY PAUL BEER

"Of all inventions, the alphabet and printing press alone excepted, those inventions which abide distance have done most for the civilization of our species."—Lord Macauley in his History of England.

The public highway has, from the earliest time, been a barometer of civilization. No matter what of progress and advancement in science, art, and commercialism, an interest in good roads invariably marks the outpost. Perhaps now, more than at any other time in the in world's history, is the public highway demanding its full share of consideration.

"If our farm life is to be made more attractive, and our agricultural resources fully developed, it is essential that the rural highways of the country be improved. However fertile the soil and however favorable the climate, the farmer cannot make any great headway toward material prosperity without improved roads. The school system may be perfect and the churches may be numerous, but if the roads are bad, the farmer is isolated from both. If these statements

be accepted as true, it must follow that without road improvement we can expect no very great social, moral, mental and material development on the farm."

### PRESENT STATUS OF ROAD IMPROVEMENT

The problem of building country roads to suit traffic is the one great problem relating to modern highway construction. An ever increasing volume of traffic and weight of loads, and the advent of swift moving vehicles, are bringing about a transitional state in our traffic conditions similar to that which occurred 150 years ago when the wheeled vehicle superceded the pack horse. In view of present development, it is apparent that the determining factor of traffic in time to come will be the mechanically driven vehicle. These new conditions are introducing elements of destruction in addition to those which have heretofore characterized improved roadways, so that now it is apparent that however permanent, economical, and satisfactory the old methods of highway construction may



have been, they are today obsolete, extravagant, and wasteful.

The present demand is not merely that we shall have good roads, but roads that mean satisfaction and comfort to the user, economy to the taxpayer, and so constructed that the question of durability, permanency and freedom from repair is without concern.

"According to an investigation made by the office of public roads, there were at the close of 1904, 2,151,570 miles of public roads in the United States. Of this mileage, 108,232.9 miles were surfaced with gravel, 38,621.7 miles with stone, and 6,809.7 miles with special materials, making a total of 153,664.3 miles improved, or 7.14 per cent. It is estimated upon the basis of such state reports as are available that there has been an increase in macadam roads since 1904 of 12.5 per cent; of gravel, 15 per cent; and of special surfacing materials, 25 per cent; which would indicate a total of 176,429.3 miles of improved roads at the present time, or 8.2 per cent of the total mileage.

It is unnecessary to seek far to discover the causes which are responsible for the poor condition of our public roads.

"In the first place, until within the past few years, the policy of extreme localization prevailed in all of the states in the administration of the public roads, and today this policy prevails in the great majority of the states. It places upon the county, and in most cases upon the road district or township, the entire burden of constructing and maintaining the roads and leaves to it the initiative as well as the final determination as to the policy which shall be pursued in carrying on the work.

"In the second place, our road laws for the most part do not contemplate the necessity for skilled supervision in road

work; hence nine-tenths of the work done is under the direction of men who have no knowledge of road building, and who have only a passing interest in it. This is a situation which is truly amazing, for skill is demanded in practically every other line of work.

"Another element of weakness in our system lies in our method of maintenance. We repair our roads as a rule at such times as farm work will permit, and this means that the roads receive attention once or twice a year. Such a system is absurd, for certainly repairs will be more thorough and cost less money and labor if made as soon as defects appear than if the road is allowed to go almost to ruin before attention is given it."—Excerpt from a report by the United States office of public roads.

#### ECONOMIC EFFECTS OF ROAD IMPROVEMENT

At the annual meeting of the Des Moines Commercial Club in December last, a prominent railroad official averred that the railroads were actually transporting the farmers' produce for 10 per ton per mile. Compare with this certain records which have been tabulated by the United States office of public roads.

The immensity of the burden which bad roads impose upon transportation is shown in the following data: An investigation conducted by the office of public roads in 1896 indicated that the average cost of hauling on the roads in the United States was twenty-five cents per ton per mile; the average length of haul, 12.1 miles, and the average load 2,002 pounds. An investigation by the Maryland geological survey in 1899 indicated the cost of hauling in Maryland to be twenty-six cents per ton per mile. In 1906 the bureau of statistics of the department of agriculture sent letters of

inquiry to 2,800 country correspondents who reported an average cost per ton mile of twenty-three cents and an average haul of 9.4 miles. The rate of twenty-three cents is, if anything, too conservative. The report of the interstate commerce commission for the year ending June 30, 1906, showed that 265,000,000 tons of freight handled by the railroads was agricultural, forest, and miscellaneous farm products. If we assume that 200,000,000 tons, or less than 80 per cent of this total was hauled over the country roads, the cost of twenty-three cents on an average haul of 9.4 miles would be \$432,400,000. This does not include the enormous tonnage hauled by wagons to canals, wharves and docks, and with this considered it would follow that the total cost of transportation on our wagon roads is well over \$500,000,000 annually.

Accepting these figures as true, it follows that with good roads a reduction in the cost of hauling from twenty-three cents per ton mile to 11.5 cents per ton mile would mean an annual saving of \$250,000,000.

#### FOREIGN COST LOW

According to consular reports, the cost of hauling in Germany, France and England averages about 10 cents per ton per mile. Leading text-books on highway engineering give the cost of hauling on broken stone roads in ordinary condition 11.9 cents; earth roads containing ruts and mud, 39 cents; sandy roads, when wet, 32.6 cents; sandy roads, when dry, 64 cents; all of these cost figures being ton mile costs.

The cost of hauling is largely determined by the size of the load that can be hauled, the number trips that can be made in a single day and the wear and tear on teams and equipment. The influence of grades may be illus-

trated as follows: If a horse can draw a load of 1,300 pounds on a level earth road he can draw only 900 pounds on a five percent grade. Steep grades are dangerous in winter for the reason that they become slippery. They are subject to serious damage by heavy rains and if the road is covered with crushed stone without first reducing the grade, the cost of maintenance is very largely increased.

#### SMOOTH SURFACE NECESSARY

The importance of a firm foundation and a smooth surface cannot be overestimated, as next to grades it influences the size of the load and the number of trips possible to make in a day. This may be illustrated by the statement that an average horse can draw one ton on a clay road, one and two-thirds ton on the best gravel road, two and three-fourths on the best macadam, four and one-half tons on the best bituminized macadam and five tons on a brick road.

"It is essential to the prosperity of the farmer that he realize how close and intimate is the relationship of roads to agriculture. The selling price of farm products is largely determined by factors beyond the control of the farmer, and his profit is represented by the difference between the cost of production and transportation and the selling price. If he can materially reduce the cost of transportation, he thereby increases this margin of profit without increasing the burden upon the consumer, because the selling price is not increased."

Improved roads would enable the farmer to more successfully introduce the system of intensive farming. If the roads were properly improved the market would be accessible to him for any and all of the products, at all times,

which soil and climatic conditions would make possible of production.

#### LAND VALUES

"An increase in the value of farm lands is the inevitable result of any permanent improvement in the roads. This increase in value of lands has been variously estimated at from \$2.00 to \$9.00 per acre, although numerous examples are available of far greater increase in specific cases. Francis P. Loomis, United States consul at St. Etienne, France, reported to the department of state in 1891, as follows:

"The road system of France has been of far greater value to the country as a means of raising the value of lands and putting the small peasant proprietors in easy communication with the markets than have the railroads. It is the opinion of well informed Frenchmen who have made a practical study of economic problems, that the superb roads of France have been one of the most steady and potent contributions to the material development and marvelous financial elasticity of the country. The far-reaching and splendidly maintained road system has distinctly favored the success of the small landed proprietors, and in their prosperity and the ensuing distribution of wealth lies the key to the wonderful financial vitality and solid prosperity of the French nation.'

It is possible to show in detail numerous other far-reaching advantages to the farmer in addition to those already herein set forth. Suffice it to say that improved roads will bring—

Better schools and greater attendance.

Better health and quicker medical attention.

Better farms and more cultivated land.

Better crops and cheaper transportation.

Better economic conditions and more products.

Better social conditions and less isolation.

Better church attendance and better citizens.

#### ROAD MATERIALS

The manner in which high speed motor cars damage a road surface was discussed in a number of the papers submitted to the International Road Congress held in France during the year 1908. Much has been said about the suction of the broad rubber tires of motor cars drawing from the roadbed the binding material upon which its life depends, and while this is in a measure responsible for the dust nuisance and the rapid deterioration of highways subject to heavy motor traffic, it is not the chief cause of damage. Stone roads, waterbound with screenings or sand, were designed to sustain a rolling traffic, and with reasonably broad tires and moderate speed, very little damage is caused by such traffic, although the loads may be very heavy. The motor car, however, is a self driven vehicle, the power being usually applied to the rear axle and the rear wheels act as driving wheels. The tractive force or shear exerted upon the road surface by these driving wheels is doubtless the chief cause of the injury which is so apparent. The fine dust, or binding material, is not so much sucked out of the roadway by the rubber tire as it is ground out and thrown into the air by the driving wheels. As the conditions of the surface layer or the ground in which these reactions are applied are unfavorable for resisting them, they are the main cause for wear and tear on roads traveled by automobiles.



FOR MACADAM ROADS

Hence, it should be sought to give tangential cohesion and elasticity to the top surface of the roadway by a proper choice and arrangement of the material of which it is made. To this end the bitumenized macadam roadway has become the popular roadway for resistance to the tractive force of both mechanically-driven and horse-driven vehicle.

To show the possibilities in permanent road construction the following estimate of a bitumenized macadam roadway, constructed of gravel with natural lake asphalt as a binder, is submitted:

Paving cost		Per mile	Per mile
per sq. yd.	of 14 ft. road	of 14 ft. road	of 16 ft. road
	8,214 sq. yd.	9,387 sq. yd.	
Gravel at \$ .80	\$ .95	\$ 7,703.30	\$ 8,917.65
Gravel at .90	.97	7,967.58	9,105.69
Gravel at 1.00	1.00	8,214.00	9,387.00
Gravel at 1.00	1.04	8,542.56	9,762.48
Gravel at 1.20	1.08	8,871.12	10,137.96
Gravel at 1.30	1.12	9,199.68	10,513.44

This is a very conservative estimate. The different prices given are based on different prices for gravel. This type of roadway is chosen because it has been selected by the New York state highway commission as that best adapted in the way of permanent road construction

for all the needs of traffic, both motor-driven vehicle and otherwise, and which is furthermore considered an economical road in that it has a low first cost and low maintenance cost

In conclusion, bear this great fact in mind: Ninety-eight per cent of the traffic in this country goes over the public roads. Accepting this as true, think of the enormous amount wasted each year by the American people in excessive transportation charges. Further back in this article is a quotation from Mr. Francis P. Loomis, United States consul at St. Etienne, France, concerning the wonderful prosperity of the French nation. Now note this startling comparison! The United States, with its great expanse of territory has 176,429.3 miles of improved roads; France, which is but little larger than the state of New York, has 355,000 miles of improved roads. Let us stop and consider whether we shall stand still in road improvement, or whether we shall adopt an aggressive good roads policy and so keep abreast of the great world nations in all that makes for progress.—The City Hall, January, 1911.



INTERNATIONAL MUNICIPAL CONGRESS AND EXPOSITION

TO BE HELD IN CHICAGO, ILL., U. S. A., SEPTEMBER 18-30, 1911

EXPOSITION IN COLISEUM, ARMORY AND EXPOSITION GROUNDS

Chicago, March 1, 1911

Mr. W. J. Locke, Ass't Sec'y,  
League of California Municipalities,  
9th Floor Pacific Bldg.,  
San Francisco, Cal.

Dear Sir:

We appreciate very much the interest you evidence in our municipal exposition. If you will permit, we will name your organization as our Pacific

Coast Representative and will place in your hands, from time to time, the names of the municipalities or individuals in your neighborhood who are interested in this proposition.

We have just received from former Mayor James D. Phelan, a letter enclosing a list of the city officials of San Francisco whom he thinks can be interested; we have already written the Mayor and will also write the other officials. Very truly yours,

JOHN MACVICAR

PROCEEDINGS

THIRTEENTH ANNUAL CONVENTION

OF THE

LEAGUE OF CALIFORNIA MUNICIPALITIES

HELD AT

SAN DIEGO, CALIFORNIA, November 15th to 19th, 1910

---

SANITATION OF WATER SUPPLIES AND SAN DIEGO'S

WATER SYSTEM

BY EMORY E. SMITH, EMERY & CO., BEFORE LEAGUE OF CALIFORNIA MUNICIPALITIES,

NOVEMBER 17, 1910

The subject assigned to me has been rather difficult to treat as a whole—the water supply of San Diego, and commercial inspection for municipalities. So I have divided the subject into two distinct sections. I wish to say that, in addition to what I will give you regarding the water system of San Diego, Mr. M. M. O'Shaughnessy, Chief Engineer of the system, is present, and would undoubtedly be pleased to go into any matters that you may wish to inquire into, and Mr. William Smythe will also give lectures with lantern-slides, showing the details of the system; at three o'clock this afternoon, and at three

o'clock tomorrow afternoon, and at eight o'clock during the next three evenings, in the vacant storeroom opening into the lobby of the hotel, where an exhibit has been made, a general exhibit of the plans and configuration of the system. It is rather impossible to give it all in one brief picture. Moreover, this is one of the largest and most important water systems in the State, and is worth looking into in detail.

There are many things that we can do without in this world, but water is an indispensable element of the body, and is universally used by all human

beings. Its purity and healthfulness, therefore, becomes a question of the first magnitude, second to none, affecting the human race.

In the last few years, great strides have been made in the advancement of sanitary science, and the purification of water has received its full share of attention, but the general public still exhibits an apathy and lack of appreciation which is difficult to understand.

The municipalities of California, except in isolated cases, have shown this same apathy and disregard of the ever-present dangers of impure water. Water-borne (carried) disease germs when taken into the human body do not affect all individuals alike, some apparently being exempt from the effects, and the germs do not always have the same degree of virulence. However, we have no means of knowing under what conditions communities or individuals are exempt, and the lessons of the past have taught us that polluted water is at all times a menace to the individual and the community, and the only method of removing the danger is to adopt methods of purification.

Statistics covering a considerable number of years show conclusively that improved sanitary condition of municipal water supply has almost without exception shown immediate response in the improved healthfulness of the community, not only in lessening cases of typhoid fever, but in general health.

Contaminated water is well understood to be one of the principal vehicles in the dissemination of pathogenic bacteria, of which the bacillus typhus is one of the most dangerous. This danger is ever present where human beings and possibly animals come in contact with the water supply, or where their ejecta is carried either

through the run off, or through percolation, into the water supply.

The water sanitation laws of the State of California, and regulations of the State Board of Health, are stringent and operative, and it is little short of criminal negligence for a community to subject any of its individuals to needless sickness or an untimely death on account of polluted water.

Nearly all sources of water supply are subject to pollution, excepting deep artesian wells and mountain springs, and even those waters may be polluted if reservoired before use.

All lakes, reservoirs, running streams, ordinary springs and wells are in more or less constant danger of contamination and should be safe-guarded in every way, not spasmodically, as is sometimes the case, but systematically and continuously.

Water sanitation problems in California, particularly in the more arid regions, differ materially from the problems in other sections of the United States.

The supplies consist mainly of reservoired waters, replenished by a few months winter flow of streams and remaining stagnant for the balance of the year, and it sometimes happens that there is no fresh in flow to amount to anything for several years. At the same time, the temperatures of the waters are high, giving ideal conditions for the growth of foul weeds and polluting organisms of many kinds.

#### SAN DIEGO'S WATER SUPPLY

The water supply of San Diego is a typical illustration of Southern California conditions. It also affords an excellent illustration of systematic sanitary work.

The water supply has its source in a labyrinth of granite mountains 60 miles distant, having an elevation of from three





LOWER OTAY DAM, SAN DIEGO WATER SYSTEM

to four thousand feet, offering a splendid and almost uninhabited watershed.

The Morena Dam, the most distant and lying at the highest altitude of more than 3600 feet, is being built to impound water at the 150 foot contour and is designed for an added height of  $5\frac{1}{2}$  feet. It is now finished to the height of about 100 feet. The 150 foot contour will give a capacity of 15,000,000,000 gallons and the added height will give a capacity of 17,500,000,000 gals.

Barrett Dam, the foundations of which have been put in, has been designed to have a height of 175 feet and will impound 15,000,000,000 gallons of water. From a short distance above the Barrett Dam at the junction of the Pine and Cottonwood Creeks, a cement-lined conduit extends for 13.38 miles Dulzura, where the water is emptied into Dulzura Creek and then into Jamul Creek and thence to Lower Otay Reservoir, 12 miles from the end of the conduit.

This conduit, like the Morena Dam, ranks among the great engineering achievements of the State; being cut for long distances through solid granite tunneling its way through granite mountain spurs and clinging to perpendicular heights.

In the present incomplete condition of the Morena and Barrett dams, the water is impounded in the Lower and Upper Otay reservoirs. The Lower Otay dam is about 140 feet high and has a capacity of 13,000,000,000 gallons, and the Upper Otay a capacity of 1,090,000,000 gallons, the Upper Otay Dam is 84 feet high and is being used as a reserve supply. The inflow into these reservoirs through the Otay River and Jamul Creek usually covers a period of several months in the year.

The water from Lower Otay is conveyed to the filter plant 15.16 miles through a 40 to 30 inch wood stave

conduit, connecting with the Y, the filter plant and a reserve reservoir known as Cholla Heights, with a capacity of 90,000,000 gallons, the latter acting as an emergency supply in case any accident should happen to the main line.

The main line conduit both passes through and by-passes the filter plant, and as a 24 inch wood stave conduit, extends four miles to the Venturi meter where readings are taken of the city's daily consumption, and is then discharged over aerating tables into the city's University Heights reservoirs.

#### SANITATION OF THE SYSTEM

Before the present water supply was brought into San Diego some four years ago, Smith, Emery & Co. were instructed by the Southern California Mountain Water Co. to put into practice all of the latest known devices for water purification so that San Diego might have the best and purest water supply in California.

Since that time the water supply has been under constant sanitary supervision, with the result that the city is becoming famous, not only for the adequate supply, but for the purity and healthfulness of the water.

Frequent analyses are made from samples taken at various points in the reservoirs and from the filter plant. At stated intervals our engineers make trips over the watersheds, visiting all premises and examining all conditions which might in any way contribute to contamination. The Upper and Lower Otay and Cholla Heights reservoirs and the filter plant are carefully gone over twice a year, the reservoir being subjected to chemical treatment for the destruction of organic matter.

The magnitude of this undertaking can be understood when we state that the Lower Otay at this time contains

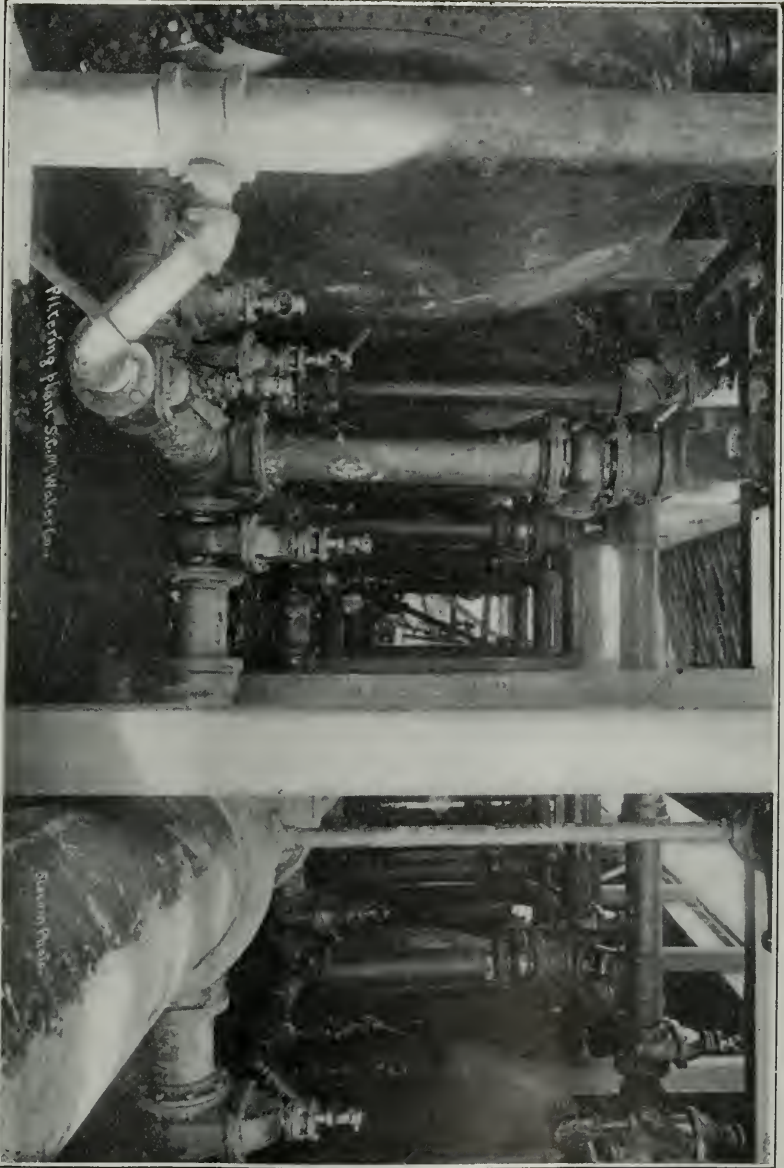

INTERIOR OF THE FILTER PLANT, SAN DIEGO WATER SYSTEM



between eight and nine billion gallons of water, and has a shore line of something like thirteen miles.

On this reservoir during chemical treatments we use a crew of from nine to ten men, three of them being engineers and chemists, and a fleet of two launches and three row boats. The treatments occupy a period of from five to seven days each, and in the course of a year from ten to twelve tons of chemicals are used.

So far as we are informed, this is the largest piece of water sanitation of its kind ever undertaken, and it has been perfectly successful. The reservoirs markedly show the effects of continuous care, the water now remaining in splendid condition the entire year.

All of the reservoirs are surrounded by fences placed a considerable distance back from the upper contour lines, and the Lower Otay is patrolled every day with a launch.

The filter plant is equipped with mechanical filters of the New York-Jewell horizontal pressure type, and consist of a battery of ten 8' by 20' filters of 500,000 gallons daily capacity each, developing, however, a surplus capacity in the aggregate of about two million gallons. Provision has been made for the addition of more filters when required.

Originally we designed the plant as a gravity system, but found that there

was not sufficient fall on the line to lose the required head. The plant was, therefore, re-designed as a pressure system.

This filter system works perfectly, and it is the most modern and best plant of its kind on the Pacific Coast. Only one man is required in attendance and for its regular operation, as a coagulent alum in small quantities is used.

The filtered water after leaving the plant passes as has been described first to the Venturi meter, four miles distant and over aerating tables of the usual type into the city's reservoirs, where the responsibility of the Southern California Mountain Water Company ceases.

The City of San Diego owns its own distributing system. The receiving reservoirs at University Heights, two in number, have a capacity of 20,792,000 gals., two steel stand pipes, having a capacity of 490,000 gallons and 442,000 gallons have also been added to the system.

The City of San Diego owns a number of other distributing reservoirs as follows:

Old Town	-	3,620,445	gallons
Point Loma, Lower		275,275	"
" " Upper		1,187,785	"
La Jolla	- -	69,115	"
Pacific Beach	- -	1,804,660	"

Giving the city a total reservoir service of about 27,749,270 gallons.

## NEED INDEPENDENT FIRE ALARM SYSTEM

Extract from the report of a special committee of expert engineers, appointed by the Mayor of Los Angeles

NOTE—Mayor Alexander recently appointed a committee of experts to investigate and report on a desirable Fire and Police signalling system for Los Angeles. Believing it will be of interest and value to the officials of all our large municipalities, we herewith publish the

principal features of the report. Plans for a similar system have just been adopted by New York City, and practically the same system is in use in our own City of Oakland. In fact, it is the system used in nearly all other large cities.

Los Angeles, Cal., March 15, 1911.

The Honorable Board of Fire Commissioners, Los Angeles, California.

Gentlemen: The undersigned committee of engineers, appointed by the Honorable Mayor of Los Angeles for the purpose of making an investigation of the proposed and other plans for the construction of a complete signalling system for the City of Los Angeles—not only for present requirements, but in general of such design and construction that the needs of the city in future years may be fulfilled with the best results and least total expenditure—begs herewith, to present the following report.

We have been guided in our work at all times by the instructions given us, "to investigate all proposed plans which may be presented or which may originate in the minds of this committee, all leading to one ultimate result, that of procuring for the City of Los Angeles a satisfactory and economical fire alarm and police signal system."

#### PRELIMINARY STATEMENTS

The committee at numerous meetings has had extended and most profitable conferences with, and obtained much information from His Honor the Mayor and members of the Fire Commission; the Chief of the Fire Department, the Police Commission, former Chief of Police Galloway and the present Chief of Police Sebastian, the City Attorney, Superintendent of Fire Alarm and Police Telegraph and other city officials, and, in addition, officers of the National Board of Fire Underwriters, and your committee desires to express its sense of deep obligation to the above mentioned individuals for their assistance and interest in our work.

Investigations have been made of, and detailed information obtained from systems for similar purposes in other cities,

and the committee has given consideration to the reports of the National Board of Fire Underwriters bearing upon the installations in Los Angeles. Various types of apparatus have been thoroughly discussed, and conclusions reached, as hereinafter stated, without regard to particular merit of any patent device or special method of construction.

#### PRESENT FIRE ALARM SYSTEM

The present fire alarm equipments have been carefully examined in detail, including the series system with a central station at the city hall, the parallel system with a central station at Thirty-second and Jefferson streets, and the series system in San Pedro. This examination has included the central office equipments, the underground and overhead distributing systems and the three types of fire alarm boxes used in connection with the three respective systems.

The central station equipment located at the city hall has been installed a number of years, and is of the automatic type. There are 315 boxes in connection with the system, of which 289 are connected and in use in the 14 different series circuits. The remaining 26 are idle and in need of repairs. All of these boxes are of the non-interfering successive type of which 171 have what is known as the double point key break, while 144 are equipped with brush breaks. The total length of the 14 series circuits is approximately 215 miles, of which 75 miles is in underground cables. The circuits in the underground cables are leased from the Home Telephone Company, and consist of No. 22 B. & S. paper insulated copper wire, making it necessary to use several in parallel in order to avoid excessive resistance in the circuits.

This system covers about two thirds of the total city, and includes all of the

so-called congested area. The number of boxes to a circuit averages nearly 21.

The parallel system in the University District has a central office equipment arranged for manual operation. There are 100 boxes connected with the system, each with a separate pair of wires running directly to the central office, thus doing away with the question of interference between boxes on outside circuits. The boxes are of the interfering type.

In addition to the two central offices above referred to, in which there are 389 fire boxes in the aggregate connected, there is an isolated automatic fire alarm system in San Pedro, which at the present time has 12 fire boxes of the non-interfering series type. It is the intention to increase this number to 22 boxes in the near future.

There are four particularly objectionable features in connection with the present fire alarm systems.

First. The central station equipment located at the city hall and taking care of the bulk of the city is of the automatic type, and entirely unsuited for work of this magnitude and importance.

Second. This same central station is in a hazardous location, being exposed to great fire risks.

Third. The use of leased underground conductors for the fire alarm system is undesirable because of the lack of reliability.

Fourth. The inadaptability of the two principal systems, with their central stations at the city hall and at Thirty-second and Jefferson streets, is very objectionable, there being no reliable complete operation of the two systems as one.

There are a number of other objectionable features, some of which are of considerable importance, but which are much more easily remedied. Among them may be mentioned the old type of

brush contact in about one half of the series boxes, and the fact that there are entirely too many boxes per circuit in the series system centering at the city hall, particularly in those circuits covering the more important and congested areas.

#### GENERAL CHARACTER OF REPORT

In framing the main body of the report, being that containing recommendations looking to the future, as well as the immediate necessities, your committee has thought best not to include too much technical detail.

The best possible system for the present or future city is without question one having a single central office located near the future wire center of the greater city, this central office equipment to be housed in a building so isolated from other structures and of such construction as to be practically free from injury or destruction by fire.

The office equipment should be of such a character that the system of connections to the individual boxes and auxiliary stations will introduce no serious complications in the future, when the number of boxes required may be largely increased. Simplicity is the essence of success, both as to outside circuits and central office equipment. The central office should be of the manual type, and two operators should be on duty in this office at all times.

The central office equipment should include registers and tappers, on which box signals may be received, and transmitters by means of which alarms may be sent to the Fire Department houses by automatically repeating from box circuits, subject to control of manually operated interlocking switches, also a manually operated transmitter speeded for both "fast" and "slow" time.

Each fire alarm box should have a



telephone jack as a part of its equipment, so that any member of the Fire Department or other authorized city official can, with the use of a hand telephone set, communicate with headquarters or be connected through the private branch exchange with any station of the telephone system, as desired.

As a necessary part of the fire and police signalling system records, a large map, drawn to a scale of about 400 feet to the inch, should be made and properly mounted, so that all data regarding the location of boxes, circuits, etc., may be set forth upon it. The greatest care should be taken to keep this map up to date.

Your committee, after having given the matter of the location of the proposed central office the most careful consideration, cannot but recommend that the best present location for the central office of the fire alarm and police telegraph system would be in a suitable artistic structure located in Central Park. If this for any reason cannot be done, it would unquestionably be better to locate the central office farther south.

Second in importance to the necessary removal of the central office equipment from the city hall to a new central office building is the abandonment of the use of leased or rented telephone conductors in the underground district in the operation of the fire alarm system. All underground and overhead cables and conductors in connection with the entire system should be owned and controlled by the city.

Your committee has given the matter of the leased underground telephone cables careful consideration, and as a result we beg to advise that an investment of not to exceed \$13,275.00 by the city in lead covered cables, each conductor to be not less than No. 14 B. & S. gauge, to be drawn in the duct of the

Pacific Telephone and Telegraph Company, which is available free of expense to the city for the housing of such cables, would result in an annual saving of the amount paid for the rental of cables, or nearly \$5,000.00 per year. At the same time, the innumerable difficulties and interruptions resulting from the use of telephone cables containing conductors, some of which are used for telephone and others for fire alarm purposes, would be entirely eliminated.

Due to no fault whatsoever of the Home Telephone Company, these rented telephone cables have caused many false alarms; in fact, the entire fire and police signalling systems in the downtown district may at any time be put entirely out of commission as a result of minor accidents or troubles in the cables or other equipment of the telephone company.

The 315 series boxes now owned by the city will fulfill all of the requirements for this particular type of box for years, and the system may be so designed as to eliminate the necessity of ever purchasing additional boxes of this type. One hundred and forty-four of these boxes should be slightly modified, substituting double point key breaks with platinum or hard silver contacts for the brush breaks with which they are now equipped. All additional fire alarm boxes which the city may purchase need be no more complicated than the box ordinarily known as the non-interfering series type.

All the fire boxes now installed and in use in connection with the University Station can without doubt be utilized as a part of the reconstructed fire alarm system. Minor changes in the internal equipment of these boxes may be necessary, but the cost of such changes will be of small moment.

It is questionable whether in any fire

alarm system the use of a pair of conductors to every box is justified, or even desirable. In the downtown business and manufacturing districts an arrangement of distributing circuits can well be adopted, in which the conductors to each box are brought individually to the switchboard of the central station and there connected in series. Properly constructed, a series system designed so that not more than eight to ten boxes will be operated on one circuit will make possible a service that will fulfill every requirement.

For the entire area of the city, now or in the future, the practice of using an individual pair of conductors from the central office to every box is fundamentally wrong. The slight theoretical advantage is overbalanced by the decided practical disadvantage resulting from the longer and more complex distributing circuits and complicated central office equipment. Greater simplicity, reliability, economy and rapidity of operation may be obtained with the series system.

#### POLICE SIGNALLING SYSTEM

The principal features of the boxes now in use in the police signalling system are:

First. The seven distinct calls or signals provided for, and which are automatically registered at the police stations.

Second. The telephone receiver and transmitter, allowing telephone communication.

Third. The telegraph key.

Fourth. The call bell, enabling the officer on watch at the police station to acknowledge the patrolman's signal or otherwise instruct him.

Such boxes meet the requirements of the Police Department, as understood by your committee, and may be purchased in the open market if proper specifications are prepared.

The signalling is done over a single series circuit, a number of boxes being connected on each circuit. In addition to the series conductors there are pairs of wires leading out from police stations for telephone purposes, there being from 15 to 20 telephones in as many boxes, bridged across each pair. The boxes in each of the three divisions or districts into which the main city is divided for police purposes are connected by these signalling and telephone circuits to switchboards in the respective police stations.

The telephone system should be made complete, with private branch exchanges at each police station and in the chief's headquarters, so that communication may be had between headquarters and any police station or any police box, also between any two police stations or any two boxes, and this telephone system should be used exclusively by the members of the department and such other authorized officials as may be designated.

Under date of October 20, 1910, C. M. Eccles, acting upon instructions from the Chief of Police, made a thoroughly comprehensive and complete report regarding the new police boxes desirable and the proposed red light signalling system. This report has been formally approved by former Chief of Police Galloway, and also present Chief of Police Sebastian. As a result of a number of conferences with the members of the Police Department your committee in general desires to confirm the recommendations contained in the above report.

At present there are a total of 131 police boxes in use, and Officer Eccles gives in his report in detail the proposed location of 139 new boxes. While it is not necessary to have all of these boxes installed now, it is desirable that a comprehensive system be decided upon, so that all new boxes as required

may become an integral part of the system.

Your committee believes that if an appropriation is made available to cover the aggregate cost of the central office equipment, reconstruction and extensions indicated, a most satisfactory sys-

tem can be installed, fulfilling all of the requirements of the Fire and Police Departments.

Respectfully submitted.

(Signed) THEO. B. COMSTOCK.

(Signed) E. F. SCATTERGOOD.

(Signed) C. L. CORY.



## THE EFFECT OF MOTOR TRAFFIC ON OIL MACADAM

BY S. J. VAN ORNUM, CITY ENGINEER, PASADENA, CAL.

Water-bound macadam pavement has been the standard pavement for country roads and medium traffic city streets for many decades but the advent of the automobile with its accompanying shear upon the surface has resulted in a new set of conditions which the macadam pavement as originally constructed is not suited to withstand. Swiftly moving automobile tires cause the loss of the dust and finer particles of stone by the shear of the wheels and suction of the machine, thus leaving the larger pieces of rock exposed and unbonded. The pavement is then in a condition to ravel unless means are taken to firmly bind the rock in place.

The three following general methods of treating stone roads have been used in the United States to overcome these defects in macadam roads.

- (1) Dust palliatives and surface treatment;
- (2) Mixing method;
- (3) Penetration method.

The first group embraces the sprinkling of the roadway with calcium chloride, emulsions, light asphaltic oil and tar products. The treatment is only temporary in its nature and requires frequent applications.

The mixing method necessitates mixing the stone with either asphalt or tar

by hand or in specially constructed mixing plants. Also the materials composing the pavement must be heated when incorporated with refined asphalt or tar which again complicates the construction and increases the cost of the pavement.

Pavements constructed by the penetration method require the application and partial penetration of asphaltic oils or tar on the top course or courses of the macadam and are known in California as oil macadam. The oil macadam pavement has been in use in certain cities of this state for the past several years.

The general method of constructing oil macadam pavement which has been used in Pasadena is similar to the construction of macadam roads, except that heavy California asphaltic oil is applied to the top layers of rock. On the base rock which is brought up to within one and one-half ( $1\frac{1}{2}$ ) inches from the surface of the finished pavement is spread three fourths ( $\frac{3}{4}$ ) of a gallon of asphaltic oil to the square yard of street surface. A layer of rock consisting of stone from three-fourths ( $\frac{3}{4}$ ) of an inch to one and one-fourth ( $1\frac{1}{4}$ ) of an inch in size is then spread upon the rock base and thoroughly rolled with a heavy roller, after which three-fourths ( $\frac{3}{4}$ ) of



a gallon of asphaltic oil is again applied. A second course of rock from one-fourth ( $\frac{1}{4}$ ) of an inch to three-fourths ( $\frac{3}{4}$ ) of an inch in size is then placed and rolled, followed by three-eighths ( $\frac{3}{8}$ ) of a gallon of asphaltic oil. Rock screenings are then spread over the surface in sufficient quantities to absorb all surplus oil.

In constructing a street by this method, the asphaltic oil is thoroughly and uniformly incorporated with the top layers of rock, and also the pavement is trued up as the construction progresses with the result that the completed pavement has a uniform surface. After a few months traffic this surface closely resembles sheet asphalt, being dustless in the summer and mudless during the winter rains. It also has the advantage that when the surface of the oil macadam is wet, horses do not slip nor automobiles skid as they do on sheet asphalt. This city has constructed and now has under contract twelve miles of this class of pavement.

One of the first oil macadam streets constructed in Pasadena was west Colorado street from Terrace drive to Orange Grove avenue. This section of Colorado street is the main artery leading to the western and finest residential district of the city and on one of the main routes largely used by touring parties from Los Angeles. It is eight hundred and ten (810) feet in length and the hill rises abruptly for one hundred and fifty (150) feet on an eight (8) per cent. grade. The slope then gradually decreases on a four hundred (400) foot vertical curve to a two and two-tenths (2.2) per cent grade having a length of three hundred and ten (310) feet. On account of the heavy grade prohibiting the use of sheet asphalt, a six (6) inch oil macadam was selected. The pavement was constructed the lat-

ter part of 1907; completed and accepted in December of the same year. The roadway is forty-six (46) feet between curbs with three (3) feet cement gutters along each side and a standard gauge single track street railway along the center, thus concentrating the traffic to two roadways of approximately sixteen (16) feet on each side. In reality the drivers confine the traffic to a narrow strip along each side of the railroad track, which fact, coupled with the heavy grade produces most severe conditions for a pavement to withstand.

The census of the traffic per day of eleven hours passing over this portion of Colorado street was taken on Tuesday, Wednesday, Thursday and Friday, March 28th to March 31st, 1911. The traffic was found to be very uniform, varying from twelve hundred and seventy-four vehicles on March 31st to thirteen hundred and ninety-eight vehicles on March 29th. If the census had included Saturday and Sunday the maximum traffic would have been greater with a slight increase in the mean. It was found that the motor traffic passing over this street amounted to over one thousand machines a day, or over five hundred machines in each direction. The average daily traffic is given in the following tabulation:

AVERAGE DAILY TRAFFIC (Day of 11 hours)		
Horse Drawn Vehicle Traffic	East Traffic (Down Hill)	West Traffic (Up Hill)
One-horse vehicles	75	86
Two-horse vehicles	33	37
<b>Motor Vehicle Traffic</b>		
Motor cycles	42	55
Motor runabouts	103	107
Motor touring cars (4, 5 or 6 passenger)	213	239
Motor touring cars (7 passenger)	165	173

The local speed limit is twenty miles an hour, yet nearly every machine exceeds this rate in passing over the street and the writer has seen automobiles

speed up and down this hill making forty and forty-five miles an hour, it being almost impossible for a machine to make the hill on high speed unless the driver increases the velocity of the car as he approaches the heavy grade.

After nearly three and one-half years of continual traffic this pavement has required no maintenance whatever and shows no signs of ravel. The surface has worn somewhat in places until the rock is exposed in the form of a mosaic but bound firmly together by the surrounding screenings and asphaltic oil which is now hardened until it is practically an asphalt. Only one local spot of about five (5) square feet in area has appeared where the binder surrounding the rock is loosened, yet the rock is held firmly in place and this local spot has been left in this condition as a practical test of the effect of leaving the rock exposed in this manner. The cost of repairing a defect of this character is slight and the method used consists of cleaning out any loose foreign substance, cov-

ering the exposed rock with a light coating of asphaltic oil, after which sand or rock screenings are spread over the surface. The oil and sand unite thoroughly with the old pavement and form a new wearing surface. Many persons who frequently ride over this oil macadam street have always considered it sheet asphalt until they have been informed to the contrary.

From experience in the construction and maintenance of oil macadam and a study of the traffic passing over these pavements for the past several years, the writer believes that the oil macadam overcomes the defect in the water bound pavement, due to motor car traffic and embraces those principal factors which should control the selection of a proper pavement for residential streets, light traffic city streets, and a majority of country roads, as this pavement properly constructed will withstand heavy automobile traffic, is dustless and mudless, is reasonable in first cost and is easily maintained.



## SEBASTOPOL'S WATER SYSTEM

The Town of Sebastopol owns its water system. The system cost originally \$37,000 while about \$3000 more have been expended in betterments, making its total cost \$40,000.

It has been in operation five years. The report of the Superintendent for the year 1910 recently made, shows income from water sales

At 20 cts. per M. gal.	\$2924.38
Operating expenses, Power,	
Salary of Engineer etc., for 1910	1749.73
Net income (Profit) 1910	<u>\$1174.65</u>

In addition to an abundant supply of water to consumers the system may be properly credited with water for street sprinkling, sewer flushing, fire purposes and lawn and park irrigation.

## EDITORIAL

The Merchants' Association of San Francisco, in June, 1910, appointed from its membership a committee of certified public accountants, to investigate the present municipal accounting system of San Francisco and report a plan for revising it to meet the growing needs of the city and with respect to modern methods. Copies of this report have been turned over to the League of California Municipalities for distribution to the various cities and towns throughout the state, and will be mailed upon application to League headquarters. A synopsis of the report is contained in an open letter to Councilman Morgenstern of Alameda by Mr. William Dolge C. R. A., one of the members of the committee, and as the matter is of such general interest we have concluded to publish it in full, as follows:

An open letter to A. W. Morgenstern,  
Member-elect Alameda City Council.

San Francisco, Cal.

April 24, 1911.

A. W. Morgenstern, Esq.,  
Alameda, Cal.

My dear Mr. Morgenstern:

Under separate cover there has been forwarded to you a copy of the Merchants' Association's Report Upon the Necessity of a Revision of the Accounting System of the City Government of San Francisco." Do not let this ponderous title, nor the fact that the report was prepared by a committee of Certified Public Accountants dissuade you from reading it. The language of the report is not technical.

The report is in no sense a criticism of any individual, nor of any administration, but rather a criticism of the ac-

counting methods which obtain in San Francisco. Among the many deficiencies noted the following six are most important:

1st. Lack of co-ordination in the accounting system of the different departments, resulting in unproductive duplication of work.

2nd. Lack of proper classification of expenditures, resulting in lack of uniformity in municipal reports.

3rd. Lack of cost statements which would develop the true operating cost of the different departments and the true cost of improvements and betterments.

4th. The entire absence of a proper accounting method for safe-guarding the city's supplies, equipments and other convertible property.

5th. The bookkeeping based upon cash receipts and cash disbursements alone, instead of also recording income and expenditure.

6th. The impracticability of preparing statements from the books which will enable the legislative council to judge fairly the amounts required annually by each department for operating expenses and for improvements.

These deficiencies are as apparent in the accounting of the City of Alameda, and in most municipalities of the State of California, as they are in San Francisco, and it was this fact that led the Merchants' Association to say in the preface of the report:

"The Board of Directors of the Merchants' Association believed that it was possible to provide some practical scheme for a system of municipal accounts, which would not only remedy these deficiencies at present existing in the City of San Francisco, but which it was hoped might be adopted by other municipalities in this and other states as a basis for their accounting systems. If this were done, such cities could then



furnish municipal reports upon a uniform plan and the expense of the various municipal functions in each could be intelligently compared."

The report touches briefly upon what has been accomplished in standardizing municipal accounts in foreign countries and in the United States, and then proceeds to point out the principal deficiencies in San Francisco's present accounting procedure. The remedies for these deficiencies is suggested—a proper system of municipal accounting.

The results to be obtained from such a proper system of municipal accounting are then stated:

1st. The classification of all revenues and expenditures upon a definitely determined basis in general conformity with the classifications recommended by the National Municipal League. This would present to the public a view of the relative efficiency of administrations and a comparison of governmental costs with those of other cities, and would inform the chief executive as to the relative efficiency of the departments.

2nd. The centralizing of authority as to all accounting matters in the Auditing Department.

3rd. The creation of a centralized record of municipal property. This would render it possible for the chief executive to fix the responsibility for the conservation and proper employment of these assets and would facilitate preparation of the budget.

4th. The exhibition at all times of the total liabilities of the municipality, both funded and current, together with an exhibition of all the various assets which may be employed for the settlement of such liabilities.

5th. The prevention of unintentional error and fraud in respect of:

(a) The purchase of materials and supplies.

(b) The employment of labor.

(c) The fulfillment of contracts.

(d) The consumption of supplies and the employment of equipment.

(e) The collection of revenues.

(f) The custody of funds.

6th. The simplification of the methods employed in business dealings between the municipality and the public, thereby encouraging merchants to enter into commercial dealings with the city and permitting them to quote prices upon a regular mercantile basis; all this tending to reduce the cost of government.

7th. The establishment of uniformity in the methods of the various departments.

The installation of such a system would make it possible to prepare weekly and monthly reports, instead of quarterly and annual reports at a minimum expenditure of labor, thus giving both the council and the public an opportunity to criticise intelligently the administration of the municipal affairs.

In conclusion permit me to congratulate both your good self and the City of Alameda upon your election.

Faithfully yours,

WILLIAM DOLGE.

## TRADE NOTES

The officers of the Wisconsin State Automobile Association have accepted the offer of the J. I. Case Threshing Machine Co., of Racine, Wisconsin, and will use a Case Touring Car, during the Annual State Reliability Run next July, for the Technical Committee.

Thus it is that a Case car heads the Wisconsin State Reliability Run.

The Company received, yesterday, an acceptance of the offer signed by Mr. James T. Drought, of the Executive Committee.

**33** Seagrave Motor Propelled Fire Machines now in service on the Pacific Coast.  
**21** more being built for this territory.

There are good business reasons for the above remarkable showing, one is—We build nothing but F. D. Apparatus, and **TO ORDER ONLY.**

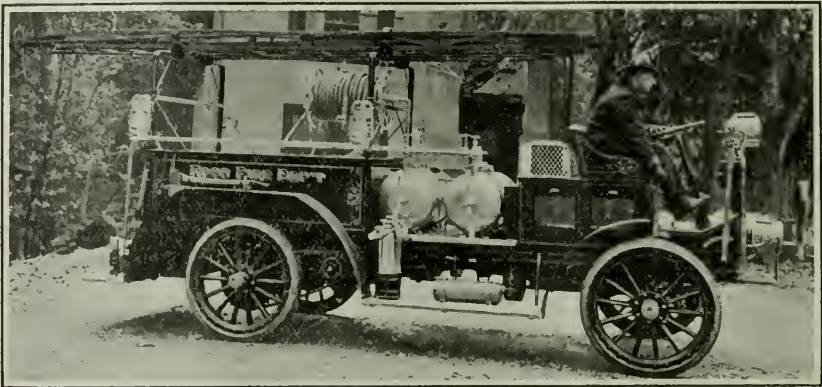

IN SERVICE AT ROSS, MARIN COUNTY, CAL.

Sold by **GORHAM ENGINEERING & FIRE APPARATUS CO.**

48 Fremont Street

San Francisco, Cal.

Branch Stores, Los Angeles, Cal.; Seattle, Wash.

## QUESTIONS AND ANSWERS

This department is for the use of city officials only. City Attorneys or others who may dissent from any opinion or answers given, or who may be able to give additional information of value on the subject of any inquiry, are earnestly requested to write us at once in order that we may transmit such further information to the official making the inquiry.

**Q.** Dear Sirs: After a certain job is advertised for bids and a certain time is specified for the bids to be in, and up to that time there has not been as many as desired, is it proper to accept any more bids a day or so after without advertising for new bids, even if the Board never opened the ones that were on time?

**ANS.** It is not proper to accept any more bids after the time fixed for receiving them. You should pass a resolution postponing the time for receiving bids to some later date suitable to the board, and then return the bids unopened to the parties who submitted

them, informing them of the time to which the reception of bids has been postponed.

**Q.** One of our trustees is trying to establish a business in an adjoining town. He spends most of his time there, returning to our town to spend Sunday. Has he a legal right to retain his office as trustee?

**ANS.** Sec. 52 P. C. Every person has in law a residence. A residence cannot be lost until another is gained. The residence can only be changed by the union of act and intent.

According to this definition, there

must be an intent as well as the act. The person must move with the intention of changing his residence, and his intent would have to be proved.

Q. How much power has the city trustees in a case where the Marshal gets drunk and fails to enforce the ordinance?

ANS. An Act was passed in 1880, in the form of an appendix to the Penal Code, providing that such officer becoming intoxicated is guilty of a misdemeanor. The best procedure for you to take is to have some one swear to a complaint in the Justice's Court charging him with a violation of this act, and if possible procure his conviction. If convicted his office becomes vacant under sub-division 8 of Section 996 of the Political Code. The Board of Trustees should thereupon give him formal notice that the office is vacant and immediately appoint a successor. Section 996 of the Political Code was

successfully invoked in the case of Loorbeer vs. Hutchinson, 101 Cal 272, and the marshal was removed from office.

It will probably please you to know that after ten years of effort the League has succeeded in getting the law amended so that the marshal will be appointed by the Board of Trustees hereafter.

Q. Dear Sir: In this city we have a license for insurance agents also for banks. Are they still liable to the license under the new amendment of the Constitution?

I understand that some take the position that the exemption is for the "property" and not for the "business".

The further question arises when does this exemption begin?

ANS. Insurance agents, banks, telegraph and telephone companies, express companies, and building and loan associations, are exempt from license tax under Constitutional Amendment No. 1, according to our construction of

## American Ingot Iron Culverts

### WILL LAST A LIFETIME

Because American Ingot Iron is 99.94% Pure and by reason of its purity offers a greater resistance to corrosion than any other iron or steel.

## The Purer the Iron the Less the Rust

We manufacture Culverts varying in diameter from 8 to 84 inches and will build arches of any dimensions desired. Our Culverts are lighter, stronger and in every way better than any other style of construction.



California Corrugated Culvert Company  
Los Angeles, Cal. West Berkeley, Cal.



Phones { Pac. Kearny 168  
Home J 2941

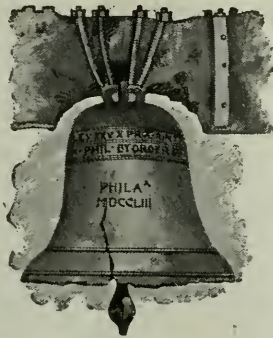

Cable Address  
GARRATT  
Codes, ABC--4th Edition  
Western Union  
Liebers

## Bell and Brass Foundry Machine and Hydraulic Works

ENGINEERS SUPPLIES

### W. T. GARRATT & CO.

277-299 Fremont Street

SAN FRANCISCO

the Amendment, but it is true, as you say, that some take the position that it refers to property and not business. We feel, however, that the intent of the law was to exempt them from the payment of municipal licenses, otherwise the word "licenses" might just as well have been omitted. Arrangements are being made to take the matter to court.

The Amendment went into effect on November 8, 1910. There is a decision covering this point which we referred to in the issue of PACIFIC MUNICIPALITIES for December, 1910.

Q. The Los Baños Chamber of Commerce would like to know what cities in this state have a water filter, or use filtered water. We would also like any information possible on the question of filtering water for city use.

ANS. There are no records showing what municipalities use filtered water, but all the larger and more important cities have their water filtered by some

process, the most common being by the means of sand; other means are used to still further clarify the water involving the use of alum and sulphate of iron. Neither one of these minerals are regarded as being in any way injurious; they cause the deposit of minute impurities, while sand is the general ingredient used to catch all the impurities of a more substantial nature.

Q. 1—May the trustees grant saloon licenses and permit the establishment of saloons in any locality they see fit, within the town, without regard to the damage which might result to adjacent property?

2—What are the lawful regulations in regard to the employment of police, their salary, etc., in cities of the 6th class? Can a person legally hold two elective offices, a municipal and a county, at the same time?

ANS. It is generally understood and accepted that the Legislative body of a municipality has full power to regulate the liquor business, and the courts have

declined to review their actions, notwithstanding the fact, that they may have acted unwisely or unjustly. The present Legislature has given municipalities the right to the initiative, referendum and recall, and the use of one of these means would be the best method for correcting any injustice which may have been done. The situation in the case you have named is the counterpart of similar situations in every municipality throughout the State, and they often result in manifested injustice and cause a great deal of bitterness. We regret to say there is apparently no remedy. However, now, the people have the right to initiate legislation or demand that certain proposed legislation be referred to them in case they do not agree with their trustees.

Replying to your second question, will say, that the lawful regulations regarding the employment of police of-

icers, their salary, etc., in cities of the 6th class, is such as may be established by ordinance.

A person can legally hold a municipal elective office and a County office at the same time if not in conflict with any city or county ordinance.

Q. Does there exist a provision in the general municipal incorporation act giving Boards of Trustees of towns of the fifth and sixth class a right to expend such moneys for general advertising purposes through the medium of a county promotion organization?

ANS. The Legislature of 1909 amended Section 862 of Municipal Corporations Bill, adding subdivision 18 thereto, which permits the Board of Trustees of a city of the sixth class to expend such sum as they shall deem proper, not to exceed five percent of the property tax levy in any one fiscal year, for music and promotion. We believe that this amendment expressly

# EUREKA FIRE HOSE



We originated the **Seamless Rubber Lined Cotton Hose**,  
and manufacture the celebrated brands

**EUREKA      PARAGON      RED CROSS**

four ply

three ply

two ply

Eureka Fire Hose bought sixteen years ago can be seen today in regular use in the fire departments of many cities, and in the inflammable paint and dry goods districts.

The only circular and seamless woven fire hose made.

All sizes for every possible use.

**Eureka Fire Hose Mfg. Co., New York**

610 Postal Telegraph Building

SAN FRANCISCO

# Wainwright Galvanized Steel Corner Bar

For Protecting Edges of Concrete Curbs, Steps, Columns, Etc.

The only effective **Concrete Edge Protector** offered to the contracting public  
 WAINWRIGHT PATENTS—March 9, 1897. November 22, 1898. May 5, 1903.  
 March 26, 1907. August 29, 1907. August 2, 1910.

This bar has been in public use for more than ten years as the main feature of the

## WAINWRIGHT STEEL-BOUND CONCRETE CURB

THE BEST IN THE WORLD

OVER THREE MILLION FEET

In use in more than three hundred cities in the United States

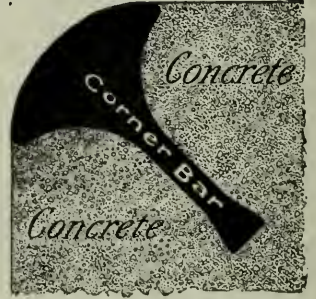

Absolutely Non-Breakable  
 Cheaper Than Granite

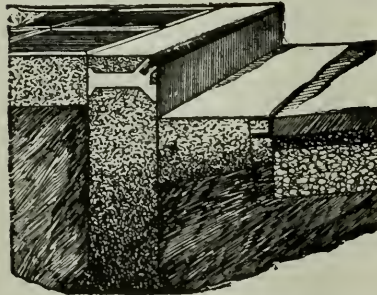

Handsome than Granite and much stronger.

Continuous in Construction, hence Never Out of Line.

**GALVANIZED STEEL CORNER BAR** Prevents Chipping or Breaking on Edges.

This Curb is Mechanically Perfect and Unequaled for Curved Corners.

**THIS CURB WILL STAND HARDER USE AND LAST TEN TIMES AS LONG AS PLAIN CONCRETE CURBING.**

Contractors can save money by laying this curb.

City Engineers can save money by specifying it.

Architects are invited to read pages 242 and 243 "Sweet's Index."

Metal Parts for Sale. Send for Copyrighted Booklet No. 19.

REAL ESTATE TRUST BUILDING  
 PHILADELPHIA, PA.

## STEEL PROTECTED CONCRETE CO.

grants authority to appropriate money for advertising purposes.

There is now under consideration\* by the present Legislature, Senate Bill No. 552, which authorizes municipal corporations, other than charter cities, to collect a tax for park music and advertising purposes, not to exceed \$ .15 on the \$100.00 valuation. This measure, however, becomes effective only in those cities, after the question has first been submitted to a vote of the inhabitants.

This last bill has passed the Senate and will pass the Assembly, and undoubtedly be approved.

There is no question in our mind, but that any city of the 6th class may expend 5 per cent of the tax levy for advertising purposes.

Q. How do the cities of the fifth and sixth class dispose of their garbage? Are incinerators manufactured for small cities?

\* Since passed and approved.

ANS. C.E. Moore, city engineer of Santa Clara, has constructed an incinerating plant for that city at a cost of five or six hundred dollars, which we understand works satisfactorily; we advise you to correspond with him. There are a number of concerns manufacturing incinerating plants, but they are all designed for large cities, and are not capable of operation, unless they are fed with a continuous supply of garbage; besides, they are very expensive and beyond the purse of a small municipality.

Q. Dear Sir: I have been requested to write to you for information in regard to the prices of "Continuous" Re-Inforced Concrete Storm Water Pipe, or pipe made and laid in the ditch.

What is the price of 3, 4, 5, and 6 foot sizes?

ANS. Your inquiry of March 23rd relating to the price of Continuous Re-inforced Storm Water Pipe, was duly



received. Our answer was delayed a little on account of the necessity of making some investigation. We found that you had made the same inquiry of the City Engineer, who states that he has sent an answer. Another company with whom we took the matter up have assured us that they would write you direct.

Q. Has a merchant who is Town Treasurer, a right to sell anything to the Town as long as he is the Treasurer?

Am I not liable to have my position taken away if I draw warrants to pay for goods bought of this merchant, or to pay any Trustee for work charged to the Town by him?

ANS. A merchant, who is Town Treasurer, cannot lawfully sell anything to the town while he is Treasurer; it is a violation of Section 886 of the Municipal Corporation Bill. The Treasurer shall be deemed guilty of a misdemeanor if he wilfully violates said Section, besides being liable for removal from office. You would not be personally liable for drawing warrant. Would suggest that you call the attention of the Treasurer and the Trustees to this Section so that they will not lay themselves open to criticism.

Q. Acting under advice received from you we recently appointed a member of the Board of Trustees as Street Superintendent. In due time he presented a bill for day's labor which the Treasurer is holding up, claiming that Section 886 of the Corporation Act makes the payment of such bill a misdemeanor.

The Treasurer has given me the following list of questions which he asks to be answered for his guidance.

While I feel that you have answered question No. 2 before, I am nevertheless sending it as it helps to show conditions:

1. Can a Trustee of a city (6th class) furnish supplies to said city and legally draw pay for the same?
2. Can a Trustee of a city (6th class) work on the street as Superintendent of Streets and legally draw pay for the same?
3. Can a Treasurer of a city (6th class) who

pays bills as indicated above be prosecuted for misdemeanor?

4. Can the Treasurer of a city of the sixth class owning the only newspaper and job office in town, publish ordinances and furnish said city with necessary printed material and legally draw pay for the same?

ANS. Responding to your inquiry of April 6th, will say that your Treasurer misinterprets Section 886 of the Municipal Corporations Act. That Section forbids any officer from being interested in any contract with the city or town. Section 852 permits the Trustees to appoint such other subordinate officers as they may deem necessary, and there is nothing in the general law forbidding the consolidation of two offices; in fact for cities of the fifth class there is a special provision for consolidating offices. The phrase "or doing any work", used in Section 886 is not intended to forbid a trustee working for the town himself, but he must not be interested in the doing of any work by any contractor. That is the way that this law is generally understood.

We answer your questions as follows:

1st. A trustee of a city of the 6th class is not allowed to furnish supplies to the city.

2nd. A trustee of a city of the 6th class may work on the streets as Superintendent of Streets and draw pay for the same.

3rd. The Treasurer of a city of the 6th class is not laying himself liable to be prosecuted for misdemeanor for paying the salary of a Street Superintendent, even though he also holds the office of trustee.

4th. No.

Q. Would ask as to what power, if any, Town Boards of Sixth class have to let contract for work to other than bidders; for example, in our town we have called for bids for certain work and feel that the bids are too high, in fact we know that work can be done privately for less, and we would if possible

like to save the readvertising and let contracts at lower figure.

Can the Board have Sewer Construction done by days work under the direction and supervision of the proper officials and save cost of advertising? We know this has been done and in some cases there is a saving to the Town. But unless this is a proper way to proceed the present Board think it best to issue call for bids.

ANS. The Supreme Court decided about a year ago that municipalities could not do any public work by letting it out by days labor, but that it must be given to the lowest responsible bidder in accordance with the provisions of Section 874 of the Municipal Corporations Bill. This decision was handed down in the case of Mathews vs. Livermore. In that case the money was raised by a bond issue, and Section 9 of the Bond Act, (No. 2371,) particularly provides that the municipality itself may employ the labor therefore. The Court held that the provision was in conflict with said Section 874, and for that reason would not stand. However, Ventura has done considerable work under what is known as the "Force Account" method, whereby the city agrees to pay the cost of the labor and material, and give a percentage to some competent man for supervising the work.

In order to make use of this method it is necessary to call for bids, and award the contract to the man who agrees to supervise the work for the lowest percentage of its cost. In view of the success they had in Ventura, this plan is well worth considering.

We are enclosing you a rough draft of "Notices Inviting Sealed Proposals", for use under this method.

See PACIFIC MUNICIPALITIES for December, 1909.

Q. Please send us copies of any ordinances you may have regulating the handling of manure and garbage, and its disposal; also, regulating the manner of sanitation with reference to stables.

ANS. Your letter regarding the problem of garbage disposal, dated April 19, was duly received this morning. This question was discussed at some length

at our meeting in Sacramento a few years ago, and the conclusion was reached that it was better for the city to take charge of the collection of garbage, and not leave it to the individual property owners.

You have a right to regulate the number of cows that may be kept within the city limits or in any particular district. You also have the right to regulate the conduct of stables, and the keeping of manure; this is done in many places, even in small towns, and it is a very desirable thing to do, as it is the principal factor in removing the fly evil. Many towns require metal lined bins for manure with a hinged cover, and provide that the manure must be removed at least once in twenty-four hours. It is much more important to remove the fly pest, as the health authorities have absolute proof that the fly does more to transmit disease than anything else known.

Another desirable provision is to require garbage to be kept in large metal cans having a tight cover. This also keeps down the fly evil, and obnoxious odors; besides it lessens the hazard from fire.

In some towns they require bins and stables to have cement floors and a special scheme for washing the same.

In conclusion, with the collection of garbage, you could provide by ordinance that it should be collected by the municipality and then you could let out the job by contract to the best bidder. Enclosed you will find some ordinances that may be of some service to you.

Q. I am enclosing herewith rough draft of proposed ordinance regulating the use of wharf. Kindly glance over it and see if it would hold water. Give your ideas along the line suggested by the ordinance.

ANS. There is a question whether you could enforce the penal cause for infractions of rules made by the Street Committee as it has been held that a legislative body cannot delegate its powers; therefore in case the Street Committee adopts any rules that are of special significance or importance, it would be advisable to afterwards adopt them as an amendment to this ordinance, in which event there would be no question about their validity.

## What the Cities are Doing

**Sausalito** is enlarging its sewer system.

**Corning** is planning a new water system.

**Merced** is about to do a lot of street paving.

**Tracy** is planning a new \$25,000 school house.

**Winters** proposes to install a \$28,000 sewer system.

**Biggs** has voted \$25,000 bonds for a new school house.

**Chico** is about to commence some extensive street paving.

**Ross** is contemplating a bond issue for street improvements.

**Chino** will vote on a \$40,000 bond issue for a water system.

**Pasadena** has voted \$475,000 for a polytechnic high school.

**Concord** voted \$29,000 bonds for a sewer system on April 1st.

**Willows** proposes to lay six or seven miles of cement sidewalks.

**Pleasanton** will add some material improvements to its water works.

**Riverside** is about to commence the construction of a new high school.

**Healdsburg** will accept bids on May 15, for construction of a sewer system.

**Selma** will have all its graded streets improved by the petrolithic process.

**Palo Alto** will vote on a proposed \$15,000 bond issue for a garbage incinerator.

**Vacaville** has voted \$15,300 for two concrete bridges, and \$25,000 for a septic tank.

**Merced** citizens have petitioned for the establishment of a municipal paving plant.

**Gridley** trustees have ordered the construction of many blocks of cement sidewalks.

**Lodi** will receive bids on May 15 for macadamizing the streets of its business section.

**Dixon** will vote on May 2, on the question of a \$40,000 bond issue for a sewer system.

**Redondo Beach** is about to lay some cement curbs and gutters, and petrolithic pavement.

**El Centro** has voted \$75,000 for a new high school. A mission style building is wanted.

**Yreka** will have cement sidewalks constructed this summer on every street in town.

**Modesto.** From all indications nearly fifty more blocks of paving will be laid in the near future.

**Nevada City** will vote on the question of issuing \$30,000 bonds for a new high school building.

**Gilroy** will hold an election on May 15 on the proposition to issue \$40,000 bonds for a new high school building.

**Pacific Grove** will vote on the proposition of issuing \$100,000 bonds for city hall, storm sewers and fire apparatus.

**Williams** will macadamize its business streets at an expense of \$17,000 and will lay many blocks of cement sidewalks.

**Hanford** wants to exchange their present chemical and hose apparatus for an anio machine. The money on hand to make up the equity.

**Orland** will vote on May 2, on two propositions; one being for an issuance of \$25,000 bonds for a sewer system, and the other \$25,000 bonds for a water works.

**Sisson** will soon vote on a \$15,000 sewer system, \$5,000 city hall and jail, and purchasing the present water system for \$20,000. A straw vote indicated almost unanimous sentiment in favor of these improvements.

**Lindsay** is making preparations to place two bond issues before the people: Sewer System and sewage disposal works, and municipal ownership of water works. The firm of Haviland & Tibbetts have been employed as supervising engineers and have men in the field now making the preliminary survey.



## LIST OF RESPONSIBLE FIRMS TO BE CALLED ON TO BID FOR PUBLIC WORK OR SUPPLIES

### WRITE FOR CATALOGS

This list is arranged as a guide for the accommodation of city officials where advertising for bids is not necessary.

#### Accountant

William Dolge, C. P. A., 255 California St., S. F.

#### Architects

W. H. Weeks, 251 Kearney St., S. F.

#### Asphalt Machinery

J. I. Case Thresh'g Mch Co. 616 Myrtle St. O'kl'nd  
A. L. Young M'chy Co. 26-28 Fremont St., S. F.  
Barber Asphalt Paving Co., S. F. & L. A.

#### Arch. Terra Cotta

Gladding, McBean & Co., Crocker Bldg, S. F.  
Steiger Terra Cotta & Pottery Wks, 729 Mills  
Bldg., S. F.

#### Automobile Public Service Wagons

The Thomas B. Jeffery Co., 117-125 Valencia  
St., S. F.  
Reliance Auto. Co., 342 Van Ness Ave., S. F.  
American La France Fire Eng. Co., 660 Mission  
St., S. F.

#### Bells

W. T. Garratt & Co., 277-279 Fremont St, S. F.

#### Bitulithic Pavement

Warren Brothers Company, Los Angeles, Cal.

#### Blue Prints

So. Cal. Blue Print & Supply Co., 800 L. A.  
Trust Bldg., Los Angeles.

#### Bridge Builders

E. T. Thurston, Jr., Wells Fargo Bldg., S. F.

#### Concrete Construction

Esterly Con. Co., Inc., 717 Market St., S. F.

#### Concrete Mixers

California Hydraulic Eng. & Supply Co.,  
S. F. and Los Angeles

#### Constructing Engineers

Fred'k C. Roberts & Co., 221 Sheldon Bldg, S. F.  
Cal. Hydraulic Engineering & Supply Co.,  
San Francisco and Los Angeles

#### Consulting Engineers

Sloan & Robson, Nevada Bank Bldg., S. F.  
E. T. Thurston, Jr., Wells Fargo Bldg., S. F.  
American Engineering Corporation, 57 Post  
St., S. F.

#### Culverts

Cal. Corrugated Culvert Co., Los Angeles and  
W. Berkeley

#### Dump Carts and Wagons

J. I. Case Thresh'g Mch Co. 616 Myrtle St. O'kl'nd  
A. L. Young M'chy Co., 26-28 Fremont St., S. F.  
Watson Wagon Co., Canastota, N. Y.

#### Electrical Plants & Machinery

A. L. Young M'chy Co., Fremont St., S. F.

#### Engravers and Bond Printers

A. Carlisle & Co., 251 Bush St., S. F.  
Schmidt Lith. Co., Second & Bryant Sts., S. F.  
Sierra Art Eng. Co., Front & Com. Sts., S. F.

#### Engineers' Supplies

W. T. Garratt & Co., 277-279 Fremont St, S. F.

#### Fire Engines

Gorham Eng & Fire App Co., 48 Fremont St  
S. F.  
Squires & Byrne Co., 565-567 Mission St., S. F.  
Pacific Fire Extinguisher Co., 507 Montgom-  
ery St., S. F.

#### Fire Hose

Gorham Eng & Fire App Co., 48 Fremont St  
S. F.  
New York Belting & Packing Co., 129-131  
First St., S. F.  
The Gutta Percha & Rubber Mfg. Co., 34  
Fremont St., S. F.

The Diamond Rubber Co.

#### Gasoline Engines

Cal. Hydraulic Eng. & Supply Co. S. F. and  
Los Angeles

#### Machine Works

W. T. Garratt & Co., 227-229 Fremont St, S. F.

#### Municipal Accountant

William Dolge, C. P. A., 255 California St., S. F.

#### Municipal Printers

A. Carlisle & Co., 251-253 Bush St., S. F.

#### Municipal Engineers

Fredk. C. Roberts & Co., 461 Market St., S. F.  
Sloan & Robson, Nevada Bank Bldg, S. F.

#### Municipal Lighting Plants

Fredk. C. Roberts & Co., 461 Market St. S. F.

#### Municipal Water Works

Fredk. C. Roberts & Co., 461 Market St., S. F.

#### Office Furniture

H. S. Crocker Co., 674 Mission St.

#### Pavement Materials

Barber Asphalt Paving Co., S. F. and L. A.  
Warren Brothers Company, Los Angeles, Cal.

#### Pumping Machinery & Supplies

California Hydraulic Eng. & Supply Co., San  
Francisco & Los Angeles  
W. T. Garratt & Co., 277-279 Fremont St, S. F.  
Pacific Fire Extinguisher Co., 507 Montgom-  
ery St., S. F.

**LIST OF RESPONSIBLE FIRMS—Continued**

**Playground Apparatus**

A. L. Young Machinery Co., S. F.

**Riggers**

C. A. Blume Con. Co., 185 Stevenson St., S.F.

**Road Machinery**

J. I. Case Threshing Mch. Co., 616 Myrtle St., Oakland, Cal.

The Good Roads Mach'y Co., Ft. Wayne, Ind.

A. L. Young M'chy Co., Fremont St., S. F.

Petrolithic Co., 345 P. E. Bldg., L. A.

Barber Asphalt Paving Co., S. F. & L. A.

**Roofing**

Barber Asphalt Paving Co., S. F. and L. A.

**Rubber Goods**

Squires & Byrne Co., 565-567 Mission St., S.F.

The Diamond Rubber Co.

**Sanitary Wiping Rags**

The Raychester Co., 1448 Folsom St., S. F.

**Scrapers**

J. I. Case Thresh'g Mch Co. 616 Myrtle St. O'kl'nd

A. L. Young M'chy Co., Fremont St., S. F.

Petrolithic Co., 345 P. E. Bldg., L. A.

**Sewer (Concrete)**

Esterly Con. Co., Inc., 717 Market St., S.F.

**Sewer Pipe and Terra Cotta**

Gladding, McBean & Co., Crocker B'ldg, S. F.

Steiger Terra Cotta Co., Mills B'ldg., S. F.

**Sewer Systems**

Sloan & Robson, Nevada Bank Bldg., S. F.

**Sidewalks (Cement)**

Esterly Con. Co., Inc., 717 Market St., S. F.

Steel Protected Concrete Co., Phila., Pa.

**Street Signs**

A. L. Young Mch. Co., S. F.

**Street Sweepers**

A. L. Young M'chy Co., Fremont St., S. F.

**Structural Steel Erectors**

C. A. Blume Con. Co., 185 Stevenson St., S. F.

**Water Works Equipment**

California Hydraulic Eng. & Supply Co., San Francisco and Los Angeles

Insulated Wires and Cables

Wire Cloth and Netting

**John A. Roebling's Sons Co.**

S. V. MOONEY, Manager  
MANUFACTURERS OF

**Iron, Steel and Copper Wire Rope and Wire  
of every description**

Phones, Kearny 2426; Home J 1220

624-646 Folsom Street

**SAN FRANCISCO**

Works at Trenton, N. J., and Roebling, N. J.

**SQUIRES & BYRNE CO.**

565-567 Mission St., San Francisco

Dealers in all kinds of

**Double Jacket Fire Hose**

for department uses. Underwriters Linen Hose, Fire Hose Carts and Jumpers. Extinguishers and equipments for Fire Departments, also a full line of mechanical rubber goods of every description. Write for discounts and prices.

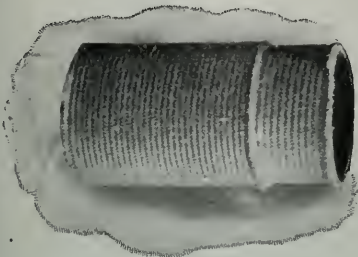

# Worswick Street Paving Company



**GENERAL CONTRACTOR**

**Sheet Asphalt, Macadam,  
Asphalt Concrete, Cement  
Concrete Constructions**

**Dealer in  
Asphalt, Crushed Rock  
Gravel and Sand**



**Main Office, Rooms 5, 8, 9, Union National Bank Building**

**Phone Main 1434**

**Cable Address "Worswick"  
Western Union Universal Code**

**Fresno, California**





Trinidad Asphalt Lake

### Trinidad Lake Asphalt

has no equal as a waterproofer. After we have used it for thirty years, everybody is learning its value for every waterproofing purpose.

# Genasco Ready Roofing

is made of genuine Trinidad Lake asphalt.

There is no roofing substitute for Genasco  
—none will last so long.

Ask your dealer for Genasco. Mineral or smooth surface. Look for the hemisphere trademark. That's a surer guide than the looks of the roofing. It is your real guarantee, but we'll write you a guarantee, if you think you need it. Write for the Good Roof Guide Book and samples.



THE BARBER ASPHALT PAVING COMPANY

Largest producers of asphalt, and largest manufacturers of ready-roofing in the world.

PHILADELPHIA

New York

San Francisco

Chicago

**Cross-section, Genasco Stone-surface Roofing**

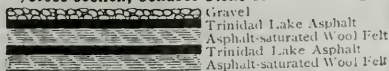

**29<sup>1</sup>/<sub>2</sub>**  
**million**  
 dollars in  
**bonds**

were voted by the people of California at the last general election—as follows:

<b>India Basin</b>	<b>\$1,000,000</b>	<b>S. F. Harbor</b>	<b>\$ 9,000,000</b>
<b>San Diego Seawall</b>	<b>1,500,000</b>	<b>State Highways</b>	<b>18,000,000</b>

The bonds are to be all steel engraved, in the highest grade of workmanship. Leading local and eastern concerns competed for the work. It was one of the largest orders of this kind ever placed on the Pacific Coast.

The bonds will be

**Supplied by**  
**A. Carlisle & Co.**

SAN FRANCISCO

A whole volume in a few words

(Agents for NATIONAL BANK NOTE CO. of Philadelphia)

# Desks, Chairs, Tables and the celebrated Globe-Wernicke Elastic Bookcases and Filing Cabinets

We carry the most complete line on the Pacific Coast.

Send for Catalogs

## H. S. CROCKER & CO.

674 Mission Street

San Francisco

TERRA COTTA, PRESSED BRICK, PIPE,  
FIRE PROOFING, ROOFING TILE,  
FLUE LININGS, FIRE TILE,  
LAUNDRY TRAYS,  
ETC.

**GLADDING, McBEAN & CO.**

WORKS  
LINCOLN, CAL.  
--- OFFICE ---  
311-317 CROCKER BLDG., SAN FRANCISCO.

# Steiger Terra Cotta and Pottery Works

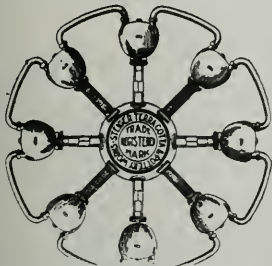

MAIN OFFICE AND YARDS:

City Yard, 18th and Division Streets

Main Office: 729 Mills Building

Phone Douglas 3010

SAN FRANCISCO, CAL.

Factory, South San Francisco  
San Mateo County



Fire Apparatus  
Police Patrols  
Ambulances

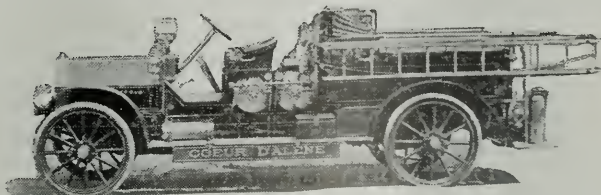

REPRESENTED BY

## RELIANCE AUTOMOBILE CO.

342-352 Van Ness Ave.

SAN FRANCISCO



## California Hydraulic Engineering & Supply Co.

### Constructing Engineers

Complete Pumping Plants for City, Fire and Irrigating Systems  
Gasoline Engines, Centrifugal and Deep Well Pumps  
Motors, Concrete Mixers and Supplies

70 Fremont Street  
San Francisco

341 South Los Angeles Street  
Los Angeles

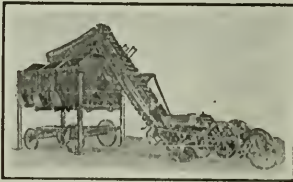

### BUILDING GOOD ROADS

is work that counts. To do this work economically you need a **Fort Wayne Mounted Rock Crusher** with Elevator, Screen and Portable Bin.

**Efficient, Serviceable and Convenient**

**Built in several sizes**

Send for catalog of Crushers, Dump Wagons, Road Graders, Steam Rollers, Sprinklers, Sweepers—Everything for Building Roads and Streets.

**The GOOD ROADS MACHINERY COMPANY, Fort Wayne, Ind.**  
Coast Representative, A. L. Young Machinery Co., San Francisco, Cal.

## PACIFIC FIRE EXTINGUISHER CO. ENGINEERS and CONTRACTORS

Pumping Plants, Hydrant Systems, Municipal Water Works, Hose and Ladder Carts, Chemical Apparatus  
Municipal Fire Alarm Apparatus, Watchman Time Detector Apparatus.

**Los Angeles**

1006 Union Trust Bldg.

**San Francisco**

507 Montgomery St.

**Seattle**

**Portland**

**Spokane**

Men in Public Service should assist in the redemption of

## LIQUOR USERS

The man who keeps his nerve propped with liquor, who feels his prestige slipping from him and his business equilibrium gone, knows that he soon will be relegated to the ranks of the "has beens," and unless able to retrieve himself from the clutches of alcohol, there will soon be written over his dead career this epitaph: "He Might Have Been." In three days

**THE NEAL TREATMENT, without hypodermic injections,**

Will cure the drink habit perfectly by a harmless process and with most pleasing after-effect. **Positively no injury can result.** Institutes in all the larger commercial centers of the United States and Canada. **Business confidential.** Write or call for full information and reference.

### THE NEAL INSTITUTE

1409 Sutter St.

Phones Franklin 1098; Home S2674

San Francisco, Cal.

# FREDK. C. ROBERTS & CO.

(INCORPORATED)

## Mechanical and Electrical Engineers

MUNICIPAL WATER WORKS  
MUNICIPAL LIGHTING PLANTS  
POWER PLANT EQUIPMENTS

461 Market Street

San Francisco, Cal.

# FIRE HOSE

THE GUTTA PERCHA & RUBBER MFG. CO.

34 Fremont St., SAN FRANCISCO, CAL.

**E. T. THURSTON, JR.**

M. Am. Soc. C. E.

**Consulting Engineer**

713 Mechanics' Institute

Phones Sutter 1683 and C 2895 SAN FRANCISCO

### **Specialties**

Design and Supervision of Buildings, Bridges,  
Sewers, Water Works, Highways, etc.

### **Concrete Bridges**

Exclusive rights under patents of National  
Bridge Company, the largest in the world.

Estimates furnished free of charge.

## C. A. BLUME CONSTRUCTION CO.

Members of Builders Exchange

**Structural Steel Erectors  
Riggers**

Phone Douglas 324  
185 STEVENSON STREET

SAN FRANCISCO

## ESTERLY CONSTRUCTION CO., Inc. CONCRETE CONTRACTORS

Buildings, Bridges, Sidewalks, Walls, Floors, Foundations  
Room 605, 717 Market St., San Francisco 2136 Center St., Berkeley



## M. Greenberg's Sons, 225 and 227 BEALE STREET Phone Kearny 276 San Francisco FIRE HYDRANTS, COUPLINGS, ETC.

Manufacturers of Engineers' Findings, Plumbers', Steamship, Brewers' & Winery Brass Goods  
Brass and phosphor bronze castings; brass and iron work of every description made and repaired

**WILLIAM DOLGE***Certified Public Accountant --:-- Municipal Accountant*

TELEPHONE DOUGLAS 5173

255 California Street

San Francisco, Cal.

**WM. H. WEEKS, Architect**PUBLIC BUILDINGS A SPECIALTY

251 Kearney Street

San Francisco

**SLOAN & ROBSON, Engineers**Reports, Designs, Estimates and Supervision of Municipal  
Light, Water and Sewer Systems

Telephone Kearney 4646

Nevada Bank Building, SAN FRANCISCO

**Create a Demand for YOUR BONDS***It Means Larger Premiums*Advertise them in **Coast Banker,** SAN FRAN-  
CISCO**AMERICAN ENGINEERING CORPORATION**

C. E. GRUNSKY, President

ALL BRANCHES OF ENGINEERING

Mechanics Institute Bldg.

SAN FRANCISCO

**THE CLARA BARTON****Sanitary Wiping Rags**

The Clara Barton Brand of Wiping Rags  
are Guaranteed to be thoroughly sterilized  
and disinfected. Telephone Market 2286

**The Raychester Co., Inc.**

1448-1460 FOLSOM ST., SAN FRANCISCO



# COUPLE REST WITH PLEASURE

by including the

## New Orleans-New York Steamship Line

Between New Orleans and New York in the routing of your ticket East. Costs less than an all-rail route and affords an interesting and delightful diversion on your trip.

### RATES

First class rail to New Orleans and First Cabin steamer to New York,	\$ 77.75
Round Trip	145.50
One way rail, one way steamer between New Orleans and New York,	70.00
Second class rail and second cabin New Orleans to New York,	65.75

RATES INCLUDE MEALS AND BERTH WHILE ON STEAMER

WRITE OR ASK ANY AGENT FOR DETAILS

# Southern Pacific

## TICKET OFFICES

Flood Building,  
Palace Hotel,  
32 Powell Street,  
Market Street Ferry Depot,  
Third and Townsend Streets Depot.  
Broadway and 13th Street, Oakland

## MECHANICAL RUBBER GOODS

FIRE HOSE  
Chemical  
Hose

EFFICIENCY  
Suction Hose  
Steam Hose

# Diamond

BELTING  
PACKING  
DURABILITY  
Water Hose  
Garden Hose



TRADE MARK REGISTERED PATENT

THE DIAMOND RUBBER CO. of N. Y.

Cor. Second and Mission Sts., SAN FRANCISCO  
Factories, Akron, Ohio

# MUNICIPAL AND CONTRACTORS' MACHINERY

...FOR...

## GOOD ROADS AND STREETS

Street Signs

National Road Machines

Fort Wayne Road Machines

Indiana Road Machines

National Elevating Graders

Elevators—Portable Bunkers

Shares or Cutting Edges for all types of Road Machines

Rock Crushers, Jaw and Gyrotory Type, mounted and unmounted

Screens

Steam Road Rollers

Horse Rollers

Scarifiers

Harrows for oiled roads

Wheeled and Drag Scrapers

Fresno Scrapers

Reversible Road Plows

Street Sprinklers

Sprinkling Attachments

Street Sweepers

Fibre for Street Sweepers

Watson Dump Wagons

Asphalt Machinery

Kettles—Hand Rollers—Tampers

Concrete Mixers

Hoisting Engines

Playground Apparatus

Culvert Pipe

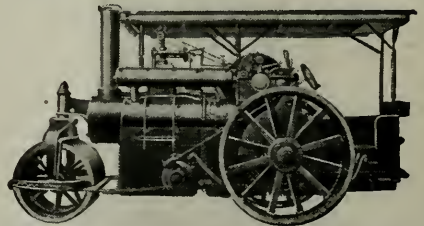

Write us for Catalogues and Estimates

## A. L. Young Machinery Co.

26-28 Fremont Street

San Francisco

California

# PACIFIC MUNICIPALITIES

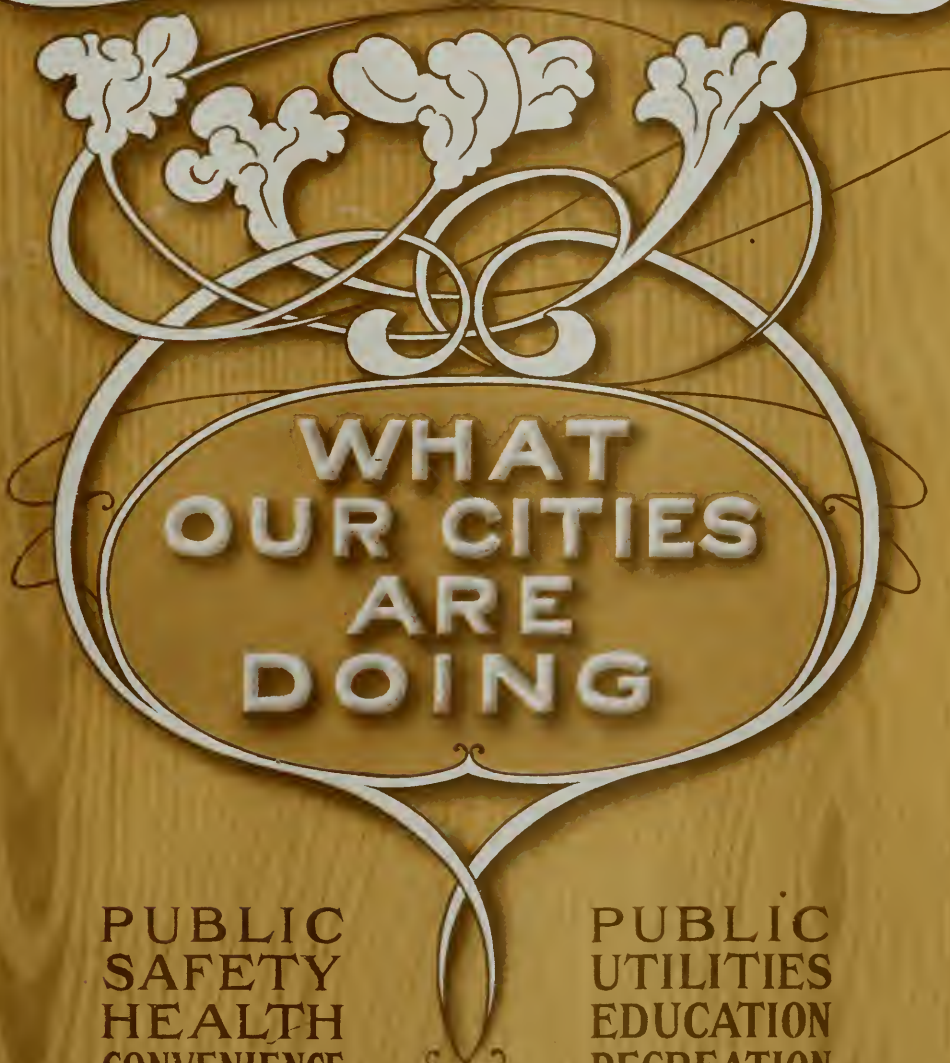

WHAT  
OUR CITIES  
ARE  
DOING

PUBLIC  
SAFETY  
HEALTH  
CONVENIENCE

PUBLIC  
UTILITIES  
EDUCATION  
RECREATION

PUBLISHED MONTHLY



**33** Seagrave Motor Propelled Fire Machines now in service on the Pacific Coast.  
**21** more being built for this territory.

There are good business reasons for the above remarkable showing, one is—We build nothing but F. D. Apparatus, and **TO ORDER ONLY.**

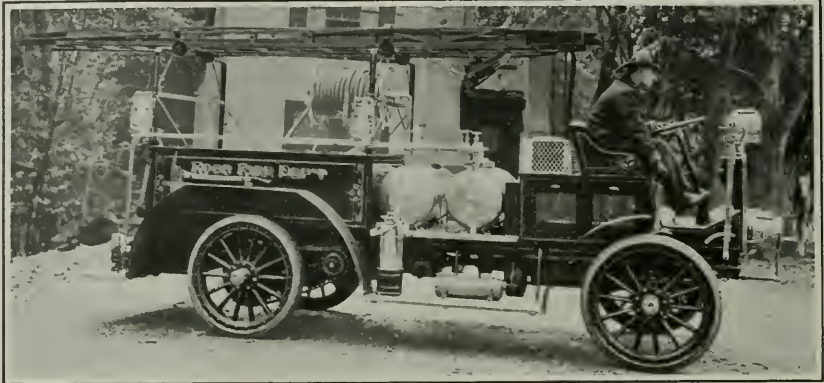

IN SERVICE AT ROSS, MARIN COUNTY, CAL.

Sold by **GORHAM ENGINEERING & FIRE APPARATUS CO.**

48 Fremont Street

San Francisco, Cal.

Branch Stores, Los Angeles, Cal.; Seattle, Wash.

**SILENT**

**LUXURIOUS**

**3 MODELS**

*THE NEW Rambler*

Touring Cars, Motor Fire Trucks, Chemical, Hose, Police Patrol and Ambulances a Specialty.

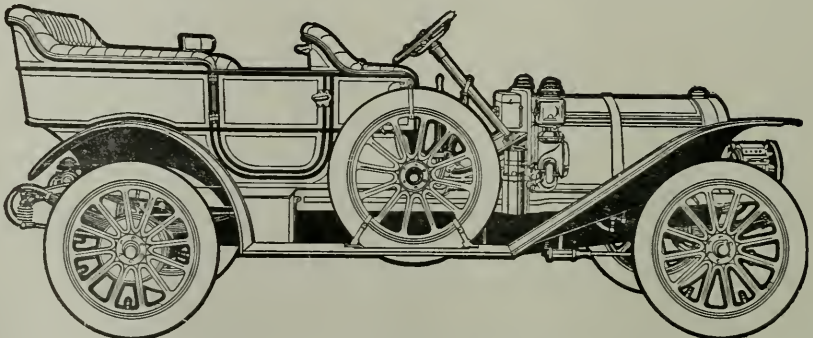

**The Thomas B. Jeffery Co.**

117-125 Valencia St.

**WRITE FOR INFORMATION.**

San Francisco

# "THE ROAD IS THE THING"

When built by the CASE Power-steered Road Roller

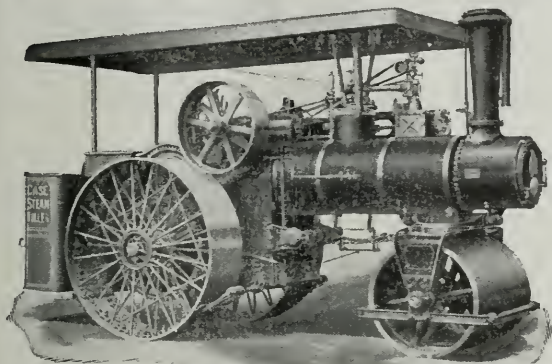

Power steering saves time over hand steering. Time saved is profit. The time saved in using a Case Roller and the extra work accomplished give increased profits to you, Mr. Contractor.

Write for Catalog on Road Roller, Road Machinery and Troy Dump Wagons and Boxes: for Contractors' General Purpose Engine and Municipal Catalog M. Address Road Machinery Dept.

Price, Simple Cylinder, \$2,200

6% discount for cash

J. I. CASE THRESHING MACHINE COMPANY, Inc. RACINE, WIS., U. S. A.

BRANCH OFFICE, 616 MYRTLE ST., OAKLAND, CAL.

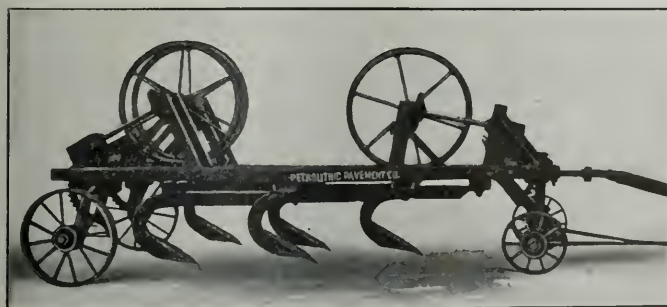

Let us tell you about the new

Petrolithic Gang Road Rooter and Scarifier

THE PETROLITHIC CO.

345 P. E. Bldg.  
Los Angeles

Wherever good Contractors are,

there the Watson dump wagon is known. It's the most used dumping wagon in America, both by contractors and municipalities.

Only one single type of wagon is made in our big factory. All our time and money is devoted to doing one thing, and doing it well. Our printed matter is as high grade as the wagon. Ask for it.

WATSON WAGON COMPANY, Canastota, New York

The First Builders of Bottom Dumping Wagons

California Agencies: San Francisco, A. L. Young Machinery Co. 26-28 Fremont St.; Los Angeles, L. M. Davenport Co.



# “BITULITHIC”

## The Ideal Boulevard Pavement

### “BEST BY EVERY TEST”

☐ BITULITHIC has been adopted as the standard pavement in more than 200 cities, all of which give unqualified praise for BITULITHIC in the earliest as well as the latest cities. More than 15,000,000 square yards BITULITHIC PAVEMENT laid and contracted for in ten years, equal to over 850 miles of 30-foot roadway, shows the rapid increase of yardage and success of the BITULITHIC PAVEMENT.

☐ The following is one of many endorsements that shows that BITULITHIC is the most essential factor in real estate development:

Mr. George O. Tenney, Pres.,  
Atlantic Bitulithic Co., Richmond, Va.

315-316 Dickson Building,  
Norfolk, Virginia, May 7, 1910

Dear Sir:—

As per your request we are offering our opinion of the Bitulithic Pavement and its influence on the value of real estate.

We believe, from comparison with various kinds of paving, that it is the most durable and satisfactory, when constructed in a high grade manner. The Seventh Ward of our city has recently completed eleven miles of Bitulithic; a large expenditure, but justified by the increased tax return from the real estate. Real estate in this ward has increased twenty-five per cent. in value.

Very truly yours,

COLLINS & VAN DENBERGH, INC.

(Signed) Paul T. Collins, President.

☐ BITULITHIC affords a superior foothold for horses in either wet or dry weather and is a sanitary, non-skidding resilient street pavement.

☐ BITULITHIC beautifies the city and enhances the value of property more than any other form of pavement.

Write today for explanatory booklets to

## WARREN BROTHERS COMPANY

59 Temple Place, Boston, Mass. 616 Laughlin Bldg., Los Angeles

(REGISTERED IN THE U. S. PATENT OFFICE)

“Bitulithic” “Warrenite” “Bitustone” “Bitrock” “Puritan” “Rockphalt”  
“Bituminous Macadam”



NOTE—Every city official in California reads Pacific Municipalities.

# Pacific Municipalities

OFFICIAL ORGAN OF THE LEAGUE OF CALIFORNIA MUNICIPALITIES

Entered at Post Office, Santa Clara, Cal., as Second-Class Matter

---

VOL. XXIV

TWELFTH YEAR

No. 4

---

EDITORS - - - H. A. MASON AND WM. J. LOCKE  
EDITORIAL OFFICE - NINTH FLOOR, PACIFIC BLD'G, SAN FRANCISCO  
PUBLICATION OFFICE, - - - SANTA CLARA, CALIFORNIA

---

## CONTENTS FOR MAY, 1911

---

Proceedings of the League of California Municipalities	133
Department of Engineers, Councilmen and Street Superintendents	133
Department of Clerks, Auditors and Assessors	142
Auditors' Duties	143
Public Comfort Stations and an Emblem for Marking Them	148
The Los Angeles Aqueduct	150
Expert Dolge Moves	158
Fine Work of Auto Fire Apparatus	158
Editorial	159
The Municipal Congress and Exposition at Chicago	159
Affiliation with County Officials	159
Warren Brothers Patent Sustained	163
Questions and Answers	161
What the Cities Are Doing	164

---

Published Monthly. Yearly Subscription, \$2.00 in Advance. Single Copies, 25 Cents

ADVERTISING RATES ON APPLICATION

Address all Communications to "PACIFIC MUNICIPALITIES" Pacific Building  
San Francisco, California

# LEAGUE OF CALIFORNIA MUNICIPALITIES

Organized 1897

## — OFFICERS —

President	(Mayor of Berkeley)	BEVERLY L. HODGHEAD
First Vice-President	(Councilman of San Diego)	A. E. DODSON
Second Vice-President	(Mayor of Santa Cruz)	T. W. DRULLARD
Secretary	H. A. MASON	Ass't Secretary Wm. J. LOCKE

## STANDING COMMITTEES

EXECUTIVE—Beverly L. Hodghead; H. A. Mason; S. C. Evans, Mayor of Riverside; Percy V. Long, City Attorney San Francisco; W. P. Butcher, City Attorney Santa Barbara.

LEGISLATIVE—W. F. Hyde, Palo Alto; J. O. Walsh, San Francisco; J. H. Strait, Redlands; F. H. Allbright, Red Bluff; B. L. Barney, Hanford.

JUDICIARY—C. N. Kirkbride, San Mateo; P. G. Sheehy, Watsonville; Stephen G. Long, Long Beach; R. E. Rhodes, Madera; Wm. J. Carr, Pasadena.

ENGINEERING—Chris. P. Jensen, Fresno; C. H. Pieper, San Jose; A. P. Noyes, Vallejo; R. C. Tunnelty, Stockton; O. E. Stewart, Anaheim.

Secretary's Office and Headquarters of the League, - Pacific Building, San Francisco

## INFORMATION BUREAU

The League of California Municipalities maintains, in connection with the Secretary's Office an Information Bureau where the officials of the municipalities belonging to the League can secure information on all subjects relating to municipal affairs

## MEMBERSHIP

Alameda	Jackson	Riverside
Albany	Lakeport	Sacramento
Alhambra	Lemoore	San Bernardino
Anaheim	Lindsay	San Buenaventura
Antioch	Livermore	San Diego
Arcata	Lodi	San Francisco
Azusa	Lompoc	San Jose
Bakersfield	Long Beach	San Leandro
Benicia	Lcs Banos	San Luis Obispo
Berkeley	Los Gatos	San Mateo
Biggs	Loyalton	Santa Ana
Bishop	Madera	Santa Barbara
Black Diamond	Martinez	Santa Clara
Burlingame	Merced	Santa Cruz
Calistoga	Mill Valley	Santa Maria
Chico	Modesto	Santa Monica
Coalinga	Monterey	Santa Paula
Colton	Mountain View	Santa Rosa
Colusa	Napa	Sebastopol
Compton	National City	Selma
Coronado	Newman	Sierra Madre
Corona	Newport Beach	Sisson
Covina	Oakland	Sonoma
Crescent City	Oceanside	Sonora
East San Jose	Orange	South Pasadena
Elsinore	Oroville	South San Francisco
Emeryville	Oxnard	St. Helena
Escondido	Pacific Grove	Stockton
Etna	Palo Alto	Suisun City
Eureka	Pasadena	Susanville
Fairfield	Petaluma	Tehachapi
Ferndale	Piedmont	Tracy
Fort Jones	Pinole	Tulare
Fowler	Placerville	Vacaville
Fresno	Pleasanton	Vallejo
Gilroy	Point Arena	Visalia
Glendale	Pomona	Watsonville
Hanford	Red Bluff	Whittier
Hayward	Redding	Willits
Hercules	Redlands	Winters
Hermosa Beach	Redondo Beach	Woodland
Hillsborough	Redwood City	Yreka
Huntington Park	Richmond	
Imperial	Rio Vista	

Every city belonging to the League of California Municipalities is entitled to a free copy of this magazine every month for each of its officials; if not received kindly notify the Secretary. See that your City is in the above list.

# PACIFIC MUNICIPALITIES

▲ Journal for Progressive Cities

VOL. XXIV

MAY 31, 1911

No. 4

PROCEEDINGS  
THIRTEENTH ANNUAL CONVENTION  
OF THE  
LEAGUE OF CALIFORNIA MUNICIPALITIES  
HELD AT  
SAN DIEGO, CALIFORNIA, November 15th to 19th, 1910  
DEPARTMENT OF ENGINEERS, COUNCILMEN AND  
STREET SUPERINTENDENTS

SESSION 9 A. M. WEDNESDAY, NOVEMBER 16, 1910

The Section was called to order by S. J. Van Ornum of Pasadena, President of the Section.

**THE PRESIDENT:** The first subject which we have upon the program is "Cement and Cement Testing." This is a very important subject, especially for Engineers and Street Superintendents, because cement is used so much now in our work.

The work depends to a great extent upon the fitness of the cement. If the cement is not up to specifications, if there are some defects in the cement, the resulting work will not be satisfactory. I take great pleasure in presenting to you Mr. William B. Gester, of the Engineering firm of Robert W. Hunt & Company, who will present a paper on "Cement and Cement Testing."

CEMENT AND CEMENT TESTING

**MR. WM. B. GESTER.** Gentlemen of the Section: I realize fully the importance of our subject, and I have come to realize also that the attempt to boil down into a ten or fifteen minute paper, the vitally essential matters only which pertain to it, results in something which is not quite satisfactory.

However I realize too that the greatest value of such papers lies in the fact that they form the basis of the discussion which follows, and therefore while I shall be tempted in going over these notes to amplify them, I shall refrain from so doing because I might spend time on some points which you would prefer spent on others, and it will be very much better, it seems to me, for you to choose the points which you de-



sire particularly to discuss after the paper is read.

Interesting as might be a fairly full discussion of this subject at this meeting, it is impossible with the time at our disposal to do more than touch upon a phase or two that have seemed to me to be of especial importance, largely because they have been strangely, and I believe unwisely neglected.

We all know so well of the very great increase during recent years in the use of Portland Cement Concrete, that figures to prove the importance of the matter are unnecessary. We all recognize the fact that this rapid growth, so rapid that it has been termed a "craze", has been greater than the growth of accurate general knowledge even among engineers and construction superintendents regarding the materials employed in its use. As regards the bonding ingredient itself, the Portland Cement, we know there are mysteries still unsolved by the experts who are making it a special study. There are some things regarding cement however that have been well demonstrated, and which might advantageously receive greater attention.

The question of "aggregates" too is a very important one. The matter of their size, proportion and physical qualities is one well worthy discussion by itself, quite as important as that of the cement, and yet one which for lack of time, one which we shall not be able to touch upon except incidentally.

The cement, and we will confine ourselves to the consideration of Portland Cement only, since it is infinitely the most important of the cements manufactured, and because of economic conditions the only one available for use on the Pacific Coast, is an artificially compounded material which mixed with water forming a plastic or semi-fluid

mass, undergoes some wonderful and rather mysterious chemical changes, gradually changing into stone. In concrete work it forms the matrix or bond which holds together the particles of sand, gravel or stone, making the artificial conglomerate.

Unless this matrix is sufficiently strong, and has the absolutely necessary element of durability, the careful design, the good quality of aggregate, the best of workmanship in construction, all will avail nothing and the concrete will be poor in quality, possibly dangerous, worse than worthless.

As manufactured and placed upon the market, cements vary greatly in character, and in quality. They vary to an infinitely greater extent than the ordinary consumer knows. Not only do the various brands differ from one another, but the best of brands will vary in chemical composition and in physical characteristics, from time to time. To be at all available for ordinary use these variations must be confined within certain limits. After years of experiment and discussion these limits have been very closely fixed, and are set forth in the Standard Specifications of the American Society for Testing Materials. These specifications provide tests for PULVERIZATION, SOUNDNESS, i. e. Permanence of volume, SETTING TIME, i. e., length of time required to pass from a state of plasticity to one of hardness, tests of STRENGTH at various periods after mixing, etc.

Thousands of experiments have shown that a Portland Cement fulfilling the requirements of the Standard Specifications, will be composed chemically within certain limits, as follows:

Lime	From 58% to 67%
Silica	" 19% to 25%
Alumina	" 5% to 10%
Iron	" 2% to 5%

Magnesia	Less than 4%
Alkalis	" " 3/4%
Sulfuric Acid	" " 1 3/4%

Whenever these limits are passed in either direction, trouble is apt to ensue.

A deficiency in lime produces a weak cement.

An excess of lime produces an unsound cement.

A deficiency of oxides, (Aluminum and Iron) or an excess of silica, makes necessary the application of a greater degree of heat than the most refractory of kiln linings can stand to produce the cement clinker.

A deficiency of silica or an excess of the oxides of Aluminum and Iron, a cement that is apt to be weak and not permanent, the aluminates being the first of the chemical compounds in Portland Cement to undergo decomposition.

The result of an excess of Magnesia has not been definitely determined, but enough is known to make it certain that a weakness ensues, and that the limit of 4% as provided in the American Specifications is a wise one.

An excess of alkalis makes a cement too rapid in set for practical use.

The sulfuric anhydride, (So<sub>3</sub>) in Portland Cement comes from the addition to the clinker before grinding, of a proportion of lime sulfate, the sulfate in the form of gypsum generally speaking, being added for the purpose of so retarding the setting of the cement that the users may be given sufficient time to place the concrete. A deficiency of sulfuric acid generally results in quick set. An excess also results in an acceleration of set, for an entirely different chemical reason however, and a subsequent weakness of the concrete.

The raw materials of which Portland Cements are made, vary as do all natural deposits. One can never be certain that two car loads of lime stone

coming out of the quarry will contain just the same proportion of lime, nor of silica, nor alumina nor iron. No two consecutive car loads of clay from the same pit can be relied upon to contain the same proportions of silica nor alumina nor iron. They may do so approximately. But frequently they vary greatly.

The proper proportions in the raw mix or meal of all these necessary constituents of the cement, are kept only by continuous sampling and chemical analysis of the most careful kind.

Variations in character of the raw material also affect the physical preparation for burning. An unexpected mass of cherty limestone in the quarry, or an unusual proportion of hard sand in a spot in the clay-pit may result in lack of sufficiently fine pulverization of the raw meal with the deplorable result of uncombined lime in the clinker, and an unsound cement.

In a well-managed plant all these things are of course continually and carefully watched and it is absolutely necessary that they should be, or the product of the plant would be unreliable and worthless.

In spite of the extremest care and caution, slips will happen, and no slip can occur without deleterious effect upon the cement.

It is further true that Portland Cement when well-made is not an absolutely stable chemical compound. Changes take place for which the cement chemist has given us no perfectly adequate and satisfactory explanation. One peculiar phenomenon is that of the change of set. An apparently normal cement will acquire a flash set, and be utterly unfit for use, and it may be without further treatment than just keeping, return in time to a normal set again. This is not a very frequent happening,

and yet no careful engineer can afford not to provide against it.

No men understand these conditions so well as the makers of cement themselves, and none are more desirous that every precaution shall be taken by engineers and superintendents to the end that no cement shall be mixed into concrete which is unfit in any particular for the purpose for which it is intended. There is no cement manufacturing concern of reputable character but is perfectly willing and indeed wishful that all its product shall be properly tested before being put into work. None appreciate more fully than the makers, the fact that a faulty piece of concrete work traceable to a brand of cement, produces conditions very difficult and tedious and expensive to recover from. And it may be taken for granted that the more careful and painstaking and jealous of good reputation a cement maker may be, the more willing and desirous he is to have his product subjected to the prescribed tests.

It is infinitely better and infinitely more economical to replace a lot of cement, discovered before use to be defective, than it is to test and then tear out completed work that has proven weak and dangerous.

Quite a number of cement manufacturing companies have published as advertisements, and have distributed among their customers, pamphlets containing the Standard Specifications for Portland Cement of the American Society for Testing Materials.

I have purposely drawn attention to the many possible causes of defects in Portland Cement, not by any means to deprecate its use, for its value as a building material cannot be overestimated, but merely to inculcate caution, to illustrate the necessity of properly testing cement before using it, a neces-

sity that is recognized so thoroughly by experts that the first paragraph of the General Conditions of the Specifications of the American Society of Civil Engineers covering Portland Cement reads as follows:

"1. ALL CEMENT SHALL BE INSPECTED."

Then follow other "General Conditions" providing for the time, place and facilities to be provided for the sampling and testing comprising the inspection. The Specifications recommend that the acceptance or rejection of cement be based upon tests made by an experienced person having the proper means for making the tests.

The tests as specified require special apparatus, but this is true also of the tests required for iron and steel and the rest of the building materials.

Only the large municipalities and corporations of the country can afford to install the testing apparatus required, and this has rendered necessary the establishment at various points of commercial testing laboratories which do for engineers and architects and construction superintendents, what for lack of facilities and because of economic conditions they can not do for themselves, and yet which they recognize to be indispensable in first class modern construction, the determination of the integrity of the materials employed.

No idea can be more fallacious than the one that the quality of a cement can be sufficiently determined by any other means than the specified tests. A mixture of finely pulverized sand or stone and a little lime will deceive all the senses of touch, sight, taste and smell.

We are able to judge quite sufficiently of the character of a piece of building timber by its appearance. In a measure this is true of building stone. To



an infinitely less degree this is true of iron and steel. To almost no degree is it true of Portland Cement.

Besides this question of determining the quality of the cement you purpose using, there is one other point that it has occurred to me to bring to your consideration, and that is the advisability when testing the cement with Standard sand thus to get at its relative value for strength, to also test the strength of both the sand and the cement you purpose using to get at the actual strength of the mortar bond in the concrete as you will make it. The sands procurable for concrete work vary so greatly in cleanliness, hardness, size and graduation of the particles composing them, as to make the proposed very inexpensive tests very desirable.

By long odds the most complete and satisfactory tests of concrete materials are compression tests of blocks of concrete made of ALL the materials which it is intended to use.

As these are not always readily procurable however, the proposed tensile tests of briquettes made of the sand and cement which are to be employed, will serve the purpose very well, giving fairly reliable indications of the strength of the mortar bond.

There is one other detail regarding Tests which it has occurred to me to speak of at this time, and that is that in order to assist in determining how soon after placing concrete, the forms may safely be removed, it would frequently be advisable to make tensile tests of briquets composed of the cement and sand used, at 14 and at 21 days, as well as at the 7 day and 28 day periods.

I suggest this because cements vary in the rapidity with which they acquire a certain necessary degree of strength. In exceptional cases this strength is acquired at the end of a week, more fre-

quently at the end of two weeks, and in others only at the end of three weeks. For the sake of safety, forms must not be removed too soon, and yet on the score of economy it is very necessary to know just how soon they may be taken down.

Now gentlemen, I will leave this matter for discussion, after just one word more. Just before I left San Francisco, we drew up a list of a lot of comparative tests made in our laboratory, covering fifteen brands of Portland Cement that were for sale in the San Francisco market a little over a year ago, including six foreign cements and nine cements manufactured on the Pacific Coast. The tests run through a period of twelve months. I had thought of reading the figures to you, but it will probably be more satisfactory if you will give me your names and addresses, such of you as may wish the information, and I will see that copies of the table are sent to you at your homes. It will be interesting to you, and very satisfactory, I haven't the least doubt, to know that the six foreign cements were among the very best imported cements that come here, and that the results of the pulling of the 360 day tests show that our domestic cements are fully as good in every respect as the barreled cements which come from abroad, and which are considerably more expensive. (Applause).

THE PRESIDENT. The paper is now open for discussion.

MR. R. C. TOMALAY of Stockton. Mr. Gester, will you please make plain the difference between Natural cement and Portland cement.

MR. GESTER. Certainly. Natural cement is manufactured of hydraulic limestone, which is an impure limestone, that naturally as you find it in the quarry, has alumina and silica and gen-

erally some iron (these in the form of clay) intimately mixed with the carbonate of lime. All that is necessary to do in the manufacture of a Natural cement is to drive off by a comparatively low degree of heat, the water and the carbonic acid that are in the hydraulic limestone, and then pulverize the calcined product. Although it is an excellent cement for some purposes, and has been used in much very important work, and was used almost entirely in this country up to about twenty years ago, it is slow in its hardening qualities and has been almost entirely superseded by Portland Cement. The latter is an entirely different product. It is made of a mixture of limestone and clay, although sometimes the lime is substituted by marl, and the clay sometimes substituted by shale. One factory in Germany makes a brand of cement called "Erz Cement" manufactured of a mixture of limestone and iron ore. But ordinarily Portland Cement is made of a mixture of limestone and clay. These are proportioned very carefully, and the mixture is then fired in a kiln. It is brought to the point of incipient fusion, forming a solid solution or alloy known as Portland Cement clinker. The clinker is pulverized, and the pulverized clinker is Portland Cement. The difference in the cementive values up to 28 days, between Natural and Portland Cements is fairly well indicated by the tensile test requirements of the American Society for Testing Materials, which are for 1 to 3 sand briquettes.

	Natural	Portland
7 Days	50lb	125lb
28 "	200lb	275lb

At longer periods the differences are less marked.

MR. C. F. WIELAND, C. E., President of the Park Commission of Berkeley. Mr. Gester has mentioned what

is absolutely essential before proceeding with large operations, and it is probably well also to mention that one can test his cement for soundness even on a very small job, having only one or two days prior to the time of the working being commenced. I think that is very important as not all of us can have large things in hand at all times. But every one of you can see that the particular cement that you have, (you may have bought it out of a store) can be immediately tested for soundness.

It is not necessary to go into what that operation is—any one of you can get the details of making that extremely simple test.

Another thing, leaving out the cement question for a moment, is as Mr. Gester dwelt on, that of the aggregate. We have been prone to say that our proportions should be, we will say, 1, 2 and 4 or 1, 2½ and 5. That really means nothing. It should be coupled with the statement that the rock shall be graded in size, and state what those sizes shall be, and likewise the sand or the gravel. But if you will say for instance, the total of your mixture shall be 1 to 6, making 7, or 1 to 7½ making 8½, and then specify how the voids shall be ascertained in that particular mass, you will get down to a possibility of having what you get in rocks,—a solid mass; otherwise the work will resemble Swiss cheese or bread, something that is full of pockets in itself. As Mr. Gester mentioned, in concrete the cement is the glue, and unless you have every particle that enters into that mass cemented, (glued) together, you have porous or spongy work. Your endeavor is to make an artificial stone; it is not to make a sponge. The next thing is that of seeing whether the aggregates that you intend using are really good. It is astonishing to see the character of sand

some people will put into concrete, and what kind of rock they will use. They forget that rock is not all of the same strength, and that all sands are not suitable for concrete. The first essential is to have good cement, and test it by all means; have it tested by a testing laboratory in large work, but if you cannot do that, certainly the next best thing is to test it for soundness yourself. Then follows the selection of the sand and the rock. You want a solid, strong mass.

THE PRESIDENT. One point I should like Mr. Gester to explain. In your tests with these fifteen brands of cement, in both the foreign and the domestic cements, did you find any that retrograded after the seventh day tests?

MR. GESTER. None that retrograded between the seven and the 28 day tests, but some that retrograded during some of the later periods, both among the neat briquettes and the mortar briquettes. Records of retrogression should be considered with judgment. It is a thing the experts have told us always to look out for, and with good reason, since retrogression may indicate unsoundness or an inherent weakness from other cause.

But we know that some of the very best cements will show a retrogression in tensile strength after say sixty or ninety days and we also know that this retrogression is not really a going back in that particular kind of strength which we require of the cement, but is an increase in brittleness. You may take the same cement made up at the same time into prisms for compression test, and break them and find no retrogression at all, but to the contrary an unchecked increase. Of course if there is a retrogression between the seven day and the twenty eight day tensile tests, it is a sign of possible unsoundness, and further

tests should be resorted to in order to determine the question definitely.

It is compression strength that we ordinarily require of concrete, so that retrogression in the sixty or ninety day tensile tests should by no means be considered sufficient cause for condemnation.

MR. A. P. CAMPBELL of Riverside. I want to ask what the status of a reground cement is. You take a cement that has been condemned, and then reground and put on the market. In what class would that be? Would such reground cement be worth anything or not?

MR. GESTER. That altogether depends upon circumstances. It depends upon what has happened to that cement. If water has reached it in sufficient quantity to cause it to change its chemical structure, it is ruined and no regrinding will restore it sufficiently to make it usable. It is true that laboratory experiments have shown that it is possible to regrind a completely hardened cement and secure a product with some cementive value. What has happened in such experiments is not that the true cementive portion of the Portland which by the addition of water had changed its chemical form and hardened into a stonelike bond had by the repulverization become changed back into a cement again, but that those particles of cement clinker which were too coarse in the first instance to have cementive qualities, and served simply as fine inert aggregates, had in the regrinding become pulverized to such an extent as to become true cement. So I should say that the regrinding of a cement killed by water might result in a material having some cementive value, but it would not be a sufficiently high value to make the reground material of practical use.

MR. W. V. DARLING, of Riverside. I would like to ask whether if a cement



has not come into actual contact with water, but merely with moisture in the air, whether that cement can be reground and make a fairly good cement—what harm comes to the cement that way?

MR. GESTER. I understand now to what you refer. Atmospheric moisture will sometimes cause cement to lose its powdery form, and become hard and lumpy. Very frequently such lumpy cement becomes quite firm, and yet tests show that it has suffered very little deterioration. In these cases the lumps may be broken up by a mallet into smaller masses which you will find may be crumbled into powder in your fingers. In order to become available for use such material must be reduced to powder by some kind or regrinding.

However, inasmuch, as Portland Cement would be entirely ruined if subjected to sufficient of even such moisture as the air may carry, it would certainly be wise to test carefully before using all cement that has become lumpy from whatever cause.

MR. F. L. JOHNSON of Santa Barbara. Mr. Gester has well spoken of the necessity for testing cements. There are some of us who have certain facilities for doing that, but not all of those that he suggests. He speaks particularly of the compression test as being a very desirable one, but for those who have not the compression test available, the suggests a parallel tensile strength test of a mortar made up of the sand which it is expected to use on that particular job. Mr. Gester has gone on further and spoken of retrogression in mortar tests, and in neat product tests in the tension machine, which did not apparently take place in the compression machine. What protection then would the engineer have if he found that his tensile strength tests of the mortar which he wishes to use were getting to be unsatis-

factory? Would he be justified in discarding the cement or discarding his mortar? Is it a satisfactory guide in determining the suitability of the material?

MR. GESTER. As I stated Mr. Johnson, I think that it is not as valuable as the compression test, if you can get the compression test, but the latter is inconvenient, not to say difficult to get, and it is comparatively expensive. The tensile test of the mortar that you expect to use is a very good guide, and that is the best we can say for it. We must do the best we can, and that is the best we can do under ordinary circumstances. In case of retrogression the engineer must take into consideration the time at which the falling back appears, its extent, and the fact that retrogression after say 60 days may be the result of brittleness only.

MR. WIELAND. Does Mr. Gester mean to make it clear that in testing the cement with the sand that you intend to use, you are really testing your sand? After you have used a standard sand for testing the cement, then you may by similar test ascertain whether the sand that you intend to use is satisfactory?

MR. GESTER. Yes. Of course the ordinary sand, such as you dig out of your own pit, or that you can buy in the open market, will not produce as strong a briquette as you make out of the standard "Ottawa" sand. The matter has been gone over quite thoroughly during the past year or two by very competent experimenters and the relationship between the tensile strength of mortar briquettes made with Ottawa sand and ordinary bank and river sands has been pretty well determined. It is found that good clean hard, types of commercial sands will make briquettes that have about seventy per cent of the strength of those made with the standard Ottawa testing sand.

MR. J. J. JESSUP, City Engineer of Berkeley. Most engineers I presume are restricted somewhat in the apparatus that is available for making these tests. I would like to ask Mr. Gester how reliable and how dependable we can consider a cement that has successfully withstood the soundness test. Suppose we test a cement by the simple rule of the "bonding test" and that seemed to successfully resist the most rigid test of that kind. How dependable is that cement?

MR. GESTER. I should say that it was dependable as far as "Soundness" is concerned. It would not cause the concrete made of it to decrepitate or go to pieces from the existence of any free lime in the product. There would be nothing to expand by the action of water and go to pieces. But of course that is not by any means the only thing you want to get when you are buying cement. You want to protect yourself against getting something that is unsafe and dangerous, but you want to get your money's worth of the type of cement you require for your purpose in the bargain. You want to be sure for instance that in the Portland Cement as you pur-

chase it, there is a fair amount of the finest ground clinker, giving you sort of line on the amount of "flour" or "float"—that is the fine cementive powder which is all the cement there is in Portland Cement.

And you will want to know that your cement is of a character that will harden within reasonable limits of time, neither too quickly nor too slowly, all this for reasons that are obvious; and you will certainly want to know that your cement will develop a reasonable amount of strength. As a matter of fact, you can hardly get an adequate idea of the value of the cement you are buying without all of the tests specified by the American Society for Testing Materials, barring perhaps the test for "Specific Gravity."

The test for "Soundness" is of prime importance, but it is not entirely sufficient and conclusive, because you want not only to be safe, but to get your money's worth.

The Department then adjourned to meet with other Departments at the Princess Theater, to witness moving picture demonstrations by the Department of Health and Sanitation.



## BAD ROADS COST MILLIONS

L. W. PAGE, U. S. DIRECTOR, GIVES ESTIMATE OF ENORMOUS LOSS TO NATION

WASHINGTON, April 8.—That the United States suffers a direct loss of \$40,000,000 annually on account of incorrect and inadequate methods, in the construction, maintenance and administration of public roads, is the assertion of L. W. Page, director of the United States office of public roads and president of the new American Association for Highway Improvement.

This enormous loss is nothing compared with the indirect loss, through excessive cost of transportation, which is caused by the burden which bad roads impose upon the farmers and others who use the highways, and this amount, according to Mr. Page's report, reaches the impressive total of \$250,000,000 every year. The American farmer is paying two or three times as much to get his products to market as the man who tills the ground in Europe, and this added cost of transportation is known to be an important factor in the high cost of living problem.

France is said to use her fine system of roads just about one and one-third times as much as her railroads for transportation, whereas, in this country, the public roads are so poorly maintained and administered, as a whole, that the highways carry only between one-third and one-fourth as much produce as the railroads. Road experts say conditions here and abroad are almost exactly reversed, due entirely to bad roads.

## DEPARTMENT OF CLERKS, AUDITORS AND ASSESSORS

NOVEMBER 16-19, 1910

The Department of Clerks, Auditors and Assessors of the League of California Municipalities was called to order by the Chairman of the Department, D. D. Kellogg of Pasadena, at nine o'clock a. m. November the 16th. Owing to the absence of the Clerk the vacancy was filled by W. R. Odom of Coalinga as pro tem Clerk.

The following members gave their names and were recorded present. Alfred Davis C. C. A. & A., Santa Barbara, L. W. Coffman, C. C., Watsonville, J. T. Butler, C. C., San Diego, M. L. Hanscom, Auditor, Berkeley, J. Smith Jr., San Diego, W. R. Odom, C. C., Coalinga, W. E. Butler, C. C., Whittier, I. S. Hatch, Auditor, Long Beach, A. Thomas, C. C., Redlands, J. A. Peoples, C. & A., Petaluma, J. N. Newkirk, A. & S., San Diego, J. L. Wright, C., Santa Cruz, A. B. Jackson, C. & A., Colusa, and Edwin Isensee, C. C., Ventura.

Due to the fact that the Secretary failed to send in the minutes of the preceding meeting their reading was dispensed with.

Mr. Hanscom of Berkeley introduced the subject of Legislation on a uniform system of accounting and talked in favor of some action being taken by the department looking to the betterment of the present condition and stated that he had prepared an article upon the subject which he would like to read at another time. The subject met with much opposition and there was no action taken thereon.

The hour of twelve, noon, having arrived, adjournment was taken until 10 a. m. the 17th.

THURSDAY, NOVEMBER 17TH

The meeting was called to order promptly at ten o'clock by the Chairman, Mr. Kellogg, and as the meeting was again without a secretary, it was moved and unanimously carried that W. R. Odom remain in the chair as permanent secretary.

D. D. Kellogg handed in an article which he, (as a committee of one named at the Santa Cruz meeting) had prepared on the subject of ASSESSING the article was read at length and on motion ordered spread on the minutes.

Mr. Hanscom again introduced the uniform accounting subject and read the article prepared by himself in support of his stand. Mr. Hanscom is an able Auditor and the article gave all food for thought, and while the plan outlined by Mr. Hanscom met with much opposition it was decided that we should make an effort to assist in gaining the end sought by Mr. Hanscom. A motion to embody the article of Mr. Hanscom in the minutes carried.

Numerous subjects were discussed but no action taken on any of them.

Owing to the fact that the 18th would be given over to other departments, it was decided to elect officers for the ensuing year. Mr. Hanscom placed in nomination for the Chairman Mr. D. D. Kellogg. The nominations were closed and the Clerk cast the ballot for Mr. Kellogg as Chairman. W. R. Odom, of Coalinga, was nominated for Clerk of the department, the nominations were closed and the Chair cast the ballot for Mr. Odom as Clerk.



A motion that the Chair name committee of four including the Chair, to arrange the program for the next meeting, carried.

The following is the committee to

serve with the Chair: M. L. Hanscom, Berkeley, J. L. Wright, Santa Cruz and Alfred Davis, Santa Barbara.

A motion to adjourn carried.



## “AUDITORS DUTIES”

FORMS, BOOKS, BLANKS, ETC., BY M. L. HANSCOM, AUDITOR OF CITY OF BERKELEY

MR. PRESIDENT AND GENTLEMEN:— All subjects involving figures are considered dry. I do not know that I have a sense of humor sufficient to make the subject, which is the matter to be considered here today, anything different, but if wit consists in brevity, I promise you that I will be witty. All things that are dry, especially those things that are extra dry, are not necessarily undesirable, but as I came from Berkeley, when things extra dry are on board, why “mum” is the word.

It has occurred to me that in addressing you upon this subject I am bringing coals to Newcastle, because many of you, perhaps all, have been discharging the duties of auditors, accountants, and clerks covering a longer term of service and dealing with larger and more complicated affairs than I have had to deal with in Berkeley; but this is a symposium for the exchange of ideas and I hope that when you have criticised my paper and pulled it all to pieces that each of us may carry back to our cities something that will help in the discharge of our duties and be an advance to the municipalities that have sent us here.

The duties of an auditor may be divided into two parts; in California, especially, auditors almost always are the accounting officers and bookkeepers, and as such have to deal with the finan-

cial conditions and needs of the city. They have also another duty which is that of examining and ascertaining the correctness and legality of claims against the city. To enable an auditor to discharge this latter duty, it is evident that he must be equipped with a thorough knowledge of the laws governing the expenditure of money even though he may have at his back the advice of an attorney. Very often cases arise in which the advice of the attorney is *ex parte*, and as he is more or less controlled by the legislative body it is not always wise to trust to his opinion. Therefore an auditor should be able to form his own opinion as to the legality of all claims. Because of his intimate and clear knowledge of the financial conditions of the city and the nature and character of expenditures he is probably better qualified than any other officer to find out and determine the expediency as well as the legality of many claims, and if the procedure in the cities is such as will admit of it, he can be of unquestionable value to the city in guarding the treasurer against expenditures that would be unwise and unprofitable, and he ought to be a valuable adviser to the board and especially to the finance committee. How far it is wise for an auditor to go in this direction, of course, is a matter which must be determined by the officer himself.

and I am inclined to think that auditors are more apt to lean towards a more prudent exercise of this duty than they ought. I am satisfied from my own experience in Berkeley that a great help has been rendered the council in disbursing money in this way and I presume that in your experience you have found something not very dissimilar.

When, some fifteen years ago, the first organized investigation of municipal government in this country was started at Philadelphia, great difficulty was encountered in gathering financial statistics, because the utter chaos, in accounting and reporting the finances of cities, made it quite impossible to reach any basis of comparison. The United States census bureau also met with the same condition, and could only compile tables of comparative receipts and expenditures, by first obtaining the necessary data through personal examination of the accounts of the cities through experts sent out from Washington.

Since that time, the great importance of a systematic, thorough, and uniform, manner of reporting on the part of municipalities, has gradually become generally recognized, and efforts have been made by the various bodies, that have, during this period sprung up in many states and cities of our country, to secure such a practice in reporting and accounting as will give to investigators and the public, such information as will enable them to judge justly and adequately, the work of the city officials.

These efforts have led to the adoption, on the part of the United States government bureau of statistics and similar state officers, a more precise and logical nomenclature, so that reports from different cities under the same heading, will relate to the same identical objects.

Although much has been done by the very able and zealous men, who are

leading the way in this movement, towards a better and very desirable accounting system; still there is very much more to be accomplished, and this must now come from the city officials throughout the country, on whom rests the responsibility of so adapting their work to meet the situation, that comprehensive, systematic, and uniform reports, based upon sensible and effective accounting systems, will be universally made.

I presume there are many accountants who hold that, so long as they show accurately in their yearly reports the receipts and expenditures of their cities, with some degree of detail, they have quite filled all requirements and reasonable demands. But in this I am sure they are mistaken. Beyond this, much is necessary and indeed is of vastly more importance.

When we consider that now almost half the population of this country resides within the limits of incorporated towns and cities, the vast interest which concerns us all in wise, economical, and efficient, administration of municipal affairs, becomes at once apparent and the need on the part of all city officials of exercising their best efforts in securing these ends, ought to appeal strongly to us all. If we are to ascertain and show, through scientific investigation and comparison, the weakness and strength of administration of civic affairs, and be able to improve conditions by profiting through the superior work of other cities; how can this be done without such a system of reporting and accounting, as will give a precise and correct data from which logical conclusions may be drawn?

Now, we in California, are perhaps more fortunately placed than many of the older states. Because of the many forms of city government, the complex-

ity of revenue laws, and the great difference in the work carried on, the older states have perplexing problems to solve in evolving a system at once comprehensive and elastic. In California, on the contrary, there is hardly any vital difference in the governmental scheme. None, certainly, that will prevent the easy adoption of a uniform system of reporting or accounting. The great obstacle will doubtless be found in the opposition, on the part of accounting officers in the smaller cities, who fear that such changes will entail more work on their part, and demand a greater knowledge of bookkeeping. I feel confident that this is wholly erroneous, and the work under the lately developed schemes of financial control in the larger cities can be adapted to the needs of a city of any size and can be made so simple and plain that anyone may use them, after a little study, more readily and with less expenditure of time and worry, than under existing practices. To do this, however, will require the application of a few fundamental principles which can be readily mastered.

There are two distinct purposes to be served in municipal reporting; one concerning, especially, the local officials and community; the other, the nation or state at large.

The city should have such a presentation of its accounts as will give to the legislative body, and the public, a knowledge complete, and accurate, of its financial affairs.

For the use of investigators, and for the student, and scientists, this should be so presented that it can be made use of in comparing the work and progress of one city with another.

In an address by Professor Charles J. Bullock, before the Massachusetts city auditors, I find the following:

"It is highly desirable from a practical point of view, as well as a scientific, that we know, in the first place, whether the expenditures are increasing more rapidly than population. In many branches they are. In some others it is not certain. We need to know, if possible, whether they are increasing relatively to the growth of wealth and industries of the country, from which must be drawn the revenue for meeting the expenditures thus created. We need to know whether the increase is uniform all along the line, and whether we must look for a continued increase of these expenditures——"

"From his point of view the city auditor or accountant is conducting a scientific experiment station. From his point of view your public official responsible for a system of accounting is conducting a laboratory in which are being worked out the data from which both the practical man and the scientific observer must get the data that are essential for the solution of some of the greatest problems of the age. So that while this movement is to be commended as of great practical value for the improvement of the financial standing of our cities, it has far reaching importance when we look upon it as a movement for gathering data essential to enable the student of modern social conditions to determine whether our civilization is tending, and whether it is likely to prove a failure or success."

Honorable Chas. F. Gillemly, Chief of Bureau of Statistics and Labor, of Massachusetts says:

"The immediate object of such a presentation was clearly to afford opportunity for comparisons, upon a uniform basis, of the financial data of all our cities and towns."

One of the first difficulties encoun-



tered was owing to the nomenclature employed by accounting officers, the terms used in different cities seldom covering precisely the same object, and often lacking precision.

In Massachusetts, so much confusion was found from this source and "there arose so many practical questions of vital importance, particularly with respect to the classification of amounts and the establishment of a proper terminology to be uniformly employed, that it was determined to call a conference of persons who had expert knowledge of the matters involved. Among those who responded to this invitation were the Honorable L. G. Powers, Chief Statistician of the Census Bureau at Washington, who was assigned to come to Boston for the purpose by the Honorable S. N. D. North, Director of the Census; Charles J. Bullock, Assistant Professor of Economics, Harvard University, and Chairman of the Special Commission on Taxation; Dr. Edward M. Hartwell, Secretary of the Statistics Department of the City of Boston; the Honorable B. Chapin, State Treasurer; and the Honorable Henry E. Turner, State Auditor."

The United States Census Bureau was the first to see the need of a uniform system of reporting, and of a terminology clear and definite, and through its efforts, and with the aid of the National League of Municipalities, and the bureaus of statistics, set up in a few of the states, a set of terms has come into general acceptance and use. Uniform schedules have also been adopted, so that where they are employed, we find that comparisons may be intelligently and justly made, and deductions drawn that will be fair and reasonable.

It is only within a few years, at most, that any attempt has been made to secure for cities, a uniform accounting

system, because it seemed almost a hopeless task, in view of the fact that none had been developed. There is absolutely no literature upon the subject and the new practice which is coming into vogue in some of the larger cities such as New York, Boston, Chicago, Los Angeles, will be followed by the adoption in the smaller municipalities of accounting systems based upon the same principles which will lead to uniformity throughout the state. Not only the incorporated towns, but counties will be brought into this movement, as will also the state, embracing all its branches.

That the benefits will be very great, it is almost self evident and we as members of the League ought to be in the van blazing the way and encouraging others to follow.

There is now but little divergence of opinion as to the form of reporting, and the terms that should be employed have been so well defined as to eliminate haziness and obscurity of expression.

By following, therefore, the work of the census bureau of those states such as Massachusetts, Ohio, Indiana, etc., as have required city statistics to be given yearly upon uniform schedules, we can not go far astray and will be very closely in line for work when California enacts a law which we hope this league will recommend and urge upon the legislature next Spring, requiring all cities to make reports on uniform schedules, to the state controller or some other state official.

When it becomes obligatory, on the part of city accounting officers, to make reports along well defined lines they will undoubtedly mould their methods, as soon as practical, to suit the needs with the greatest convenience to themselves and will be deeply interested in

devising or selecting the best system for the purpose.

As to what is the best system there will doubtless be much difference of opinion, and each officer will resolve the doubt as seems to him wisest. Any system selected ought to be flexible, elastic, accurate, and give any and all the information whenever required and at the least expenditure of time and thought.

It should enable the accounting officer, within a few days after the close of the month, or oftener if for any reason it may be desirable or necessary, to present to the council or board of trustees, a true and complete financial statement so that that body can control in an intelligent and reasonable way future expenditures; enabling them to reach a correct and business-like decision upon demands for money made by the various departments of the city.

A statement of this kind will disclose, the receipts for the month to date, and in detail; the same for the previous year, the balance of the estimated receipts for the year, the expenditures in detail for the month and to date, with corresponding amounts for the previous year; the unexpended amounts of budget items or appropriation, and a copy of the trial balance showing conditions of all the funds of the city. Authorities are drawing sharp lines between receipts and disbursements for different purposes and are using terms that are precisely defined to indicate these differences. Thus revenue and expenses are applied

strictly to the general administrative functions while off-sets-to-outlays and outlays are terms used in relation to capital accounts, this latter term embracing such as equipments, in way of buildings, machinery, etc., as are permanent and fixed in character, and are in use for a period of years and are facilities for conducting the cities' business. Separate from these again are the loan and bond accounts and still others are trust funds.

Cities, at least some of them, are issuing statements of resources and liabilities similar to such statements as are made by private corporations, banks, etc., intending to show as these latter do, the financial standing of the concern. Accountants differ as to the value of such a statement made by a municipal corporation and some of them regard such a statement as of little or no importance and as perhaps misleading.

In many ways the practice in vogue in the counting rooms of private corporations may be used with advantage by municipal corporations, but their functions are not the same, being analogous only in some particulars and comparisons should not be carried too far.

The credit of a city does not depend upon the excess of its holdings and live assets above its obligations so much as its sources of revenue which depend mostly upon its limit of taxation and the safety with which this may be depended upon to meet its bonded debt, and outstanding demands, promptly upon maturity.

## PUBLIC COMFORT STATIONS AND AN EMBLEM FOR MARKING THEM

BY A. C. SHAVER, INSPECTOR OF PLUMBING OF THE CITY OF PASADENA

When communities reach that period in their growth when it is no longer expedient that each householder shall furnish his water supply, and dispose of his own wastes, it becomes the duty of the municipality to provide for all its citizens an adequate water supply, and a safe system of sewage disposal. These may be called primary necessities, and following closely upon their provision comes the desirability of a secondary class of public utilities in which the public comfort station finds itself.

Municipalities are lavish in expenditures for park purposes, for boulevards and for band concerts, but are neglectful in providing public conveniences which will be appreciated alike by the rich and the poor, but especially by those who are not welcome in the stores, hotels or office buildings. The well to do business man has his office or his club. For the aristocratic shoppers, abundant provision is freely made. For the sight-seer, the laborer, the newsboy, no provision is made. The providing of public toilet facilities for visitors to a city does not need support by argument. The provision of such facilities for a town's own citizens is equally necessary. The absence of such places of public resort throws the burden for providing conveniences of this class upon private enterprises and in most American cities the need is met by retail merchants, hotels, restaurants, office buildings, railroad stations and saloons. Visitors to a city are strange to its local institutions and know not where to go to find such conveniences,

and, for this reason, I am placing before you for your endorsement a proposition that will eliminate this trouble, and which will fill a long felt want. In a paper read by Mr. Frank K. Chew, editor of the "Metal Worker, Plumber and Steam Fitter", at the last convention of the American Society of Inspectors of Plumbing and Sanitary Engineers which was held in Trenton, New Jersey, he spoke of the need of a universal marking for comfort stations. As this was a subject that I had been working on and which I had felt the need of in my own city, I started with renewed energy on returning home, to accomplish my purpose.

I realized that for a marking of this kind to be inoffensive to the most fastidious it would necessarily be without wording—something that would be neat and attractive, and pleasing to the eye. After many attempts in designs and colors, I placed the emblem that accompanies this paper, before the Merchant's Association and Board of Trade of our city, and received their hearty endorsement, also the endorsement of the State Board of Health. I believe that the comfort station, by relieving and preventing sickness is as much a work of the Red Cross as any other branch. In order to distinguish this emblem from others where the cross is used, we have placed the red cross in a white field, surrounded by a green circle, and the whole outlined in black. Where the accommodations are for ladies only, a letter "W" in white is placed in the center of the cross; if for men only, the letter "M" in white; if



there are accommodations for both sexes the letter is omitted. The cut, as shown is of the exact size used on the show windows. In making a canvas of our business districts, I secured permission to have this emblem placed on the windows of over forty business houses and in every bank in our city, thus throwing their toilet facilities open to the public.

At the same time the advantage of having a public comfort station near a place of business may be properly pointed out to an objecting merchant, as crowds of people are daily drawn to it, who would not otherwise come within his trade influence. It is not to be assumed that the process of educating the masses is to be accomplished at once; in fact, it is a question if it can ever be successfully accomplished; for while we have with us always the ignorant and skeptical, it is, nevertheless, true that there are many who are glad to avail themselves of the conveniences placed at their disposal. Several months after the emblems had been placed on the windows, I requested of the Secretary of the Merchants Association to find out if, in any case, the privilege had been abused, and the following is a copy of his letter:

Pasadena Merchants Association  
43 West Colorado St.

Pasadena, Cal., July 12, 1910

Mr. A. C. Shaver,  
Plumbing Inspector,  
Pasadena, Cal.

Dear Sir:

In answer to your inquiry of recent

date, I beg to assure you that while a great number of our merchants, in various lines have provided Public Comfort Stations, some for men and others for women and a few of the merchants have provided for both men and women, the locations of such stations being indicated by signs painted on their display windows, none have in the three months that your plan has been in effect, complained of a single abuse that these stations have been put to by the general public.

We believe the scheme a good one, and if it becomes universal there is no question that it would be a great boon to the public and especially to strangers.

Very truly yours,

(Sgd) A. J. BERTONNEAU  
Secretary, Pasadena Merchants Association.

The publicity Pasadena has obtained through this work is phenomenal. Not only have the trade journals throughout the United States given one and two page articles and cuts, but many magazines and daily papers have given it prominent space.

Several eastern cities have already adopted the emblem, and we are receiving communications from others, almost daily. There is no doubt that within the next few years, most American cities will be forced by an educated public demand, to install public convenience stations, and it will be well at this time to give the subject careful consideration.



## BEFORE THE GENERAL BODY

WEDNESDAY EVENING, NOV. 16, 1910

The League was called to order in evening session by the President, who

introduced Mr. J. B. Lippincott, Assistant Chief Engineer of the Los Angeles Aqueduct.

## THE LOS ANGELES AQUEDUCT

---

MR. LIPPINCOTT. About five years ago, the city of Los Angeles was confronted with a water problem, due to the rapid growth of the city and the fact that all available water supplies in that general locality had been appropriated and used. Not only were the streams in their natural beds diverted and utilized for beneficial purposes, but also the underground waters were being drawn upon by pumping plants, until the artesian area, south of Los Angeles, in that great coastal plain south of the city, had decreased in area something like 33 per cent in ten years. It would have been possible for the city of Los Angeles to erect pumping plants in that region, and invade those underground waters, but it undoubtedly would have meant that the agricultural districts which are tributary to the city would have suffered from it ultimately—not immediately but ultimately. It might also have been possible for the city of Los Angeles to have exercised her power of eminent domain and condemned some of the water supplies that were used for irrigation purposes around Los Angeles. But in doing so, it would have meant practically the wiping out of her agricultural districts, probably as fine as anything in the world and the destruction of communities that were tributary socially and commercially to the city.

Therefore the broad policy was adopted by the city, and it was a broad policy, of going to some remote source, where water was not already beneficially applied, where the minimum damage would be done, and where water could be obtained in great volume and brought into the city of Los

Angeles, not only in quantity enough for the requirements of the city, but also of all the surrounding country tributary to the city, and possibly also of our neighboring sister towns.

To give an idea of the magnitude of the supply that is being brought in, it may be stated, as I remember it, and I do not pretend that my memory is at all infallible, that the total ordinary midsummer flow of all the streams of southern California, say from Santa Barbara down to San Diego, is not in excess of about 500 cubic feet per second, and the city of Los Angeles proposed to bring in with this aqueduct a supply of about 400 cubic feet per second. We propose having enough water to supply the domestic requirements of a million people and an irrigation of approximately 100,000 acres of land surrounding the city. And when I speak of irrigation of lands surrounding the city, I wish you would keep in mind the fact that the city is growing rapidly, and that it is a very quick passage which we have in southern California from a horticultural condition into first a suburban condition and then a municipal condition. Hollywood, for instance, was a lemon and orange growing suburb but a few years ago, and today it is a portion of the city of Los Angeles. And, by a most fortunate coincident, the same amount of water which will supply the ordinary irrigated acre of land that is farmed will also supply an equal area of suburban or urban population. In other words, taking the city of Los Angeles, the consumption of water throughout the entire area of the city is approximately an inch to seven acres of land. In the

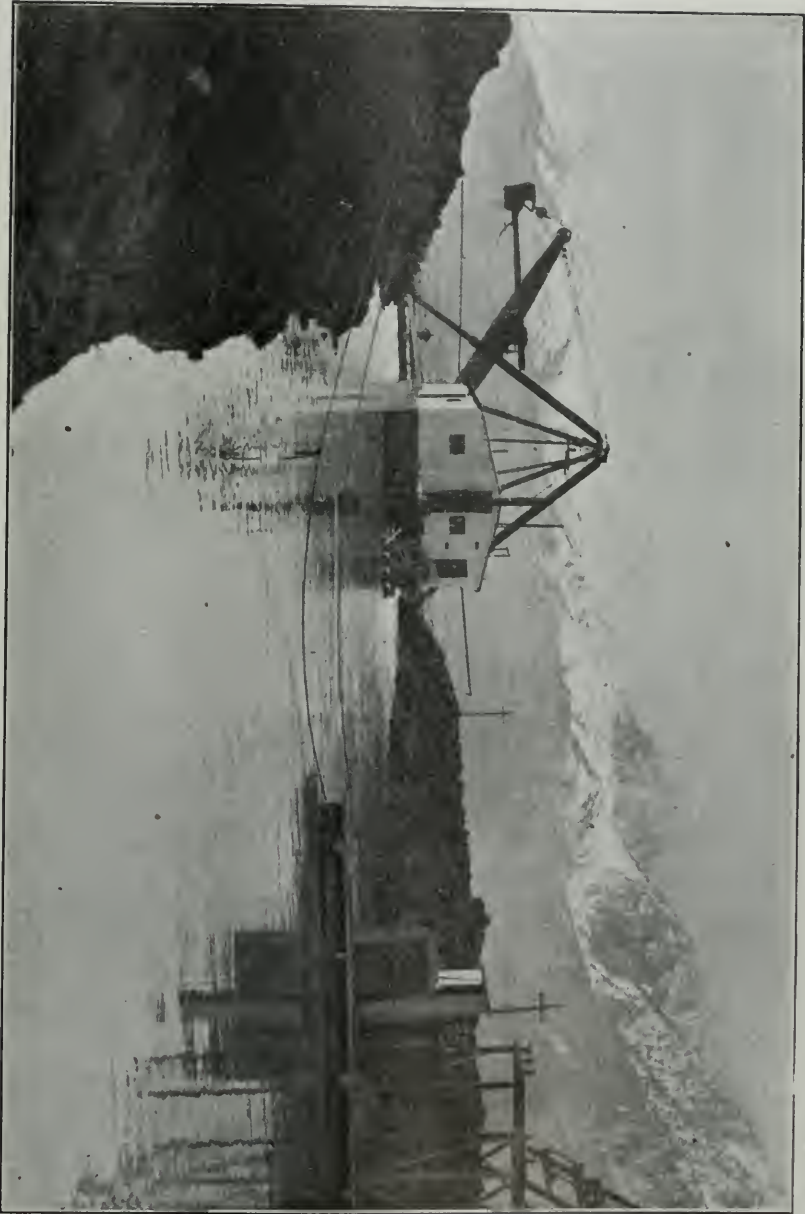

DIPPER DREDGE WORKING IN MAIN CANAL, OWENS VALLEY DIVISION



thickly settled business portions of the city, the consumption of water amounts to about an inch to five acres. So that, if this water is brought from the mountains to the surrounding country and is used for irrigation purposes, when it becomes desirable for the owners to cut those lands up, which may be in orange groves or alfalfa fields, into city lots, those owners can build on those lots as residences, and they can be occupied as city property without any change in the volume of the water supply required.

Now, I will hurriedly run through some of the pictures that I have here. In the first place, I will say that the water supply of the Owens River comes practically all of it from the eastern base of the Sierra Nevada Mountains between the mountains near the head waters of the Kern River and the Yosemite National Park.

If San Francisco gets its water supply from the Hetch-Hetchy Valley, they practically will drain or obtain their supply from the western base of the same mountains from which we get our water supply at the eastern base. That is not absolutely true, but it is true within a distance of four or five miles. We have a range of mountains extending from a few miles below Mt. Whitney to the Yosemite National Park, 120 miles in length, with 40 peaks over 13,000 feet in elevation, and containing among their number the highest peaks in the United States.

The diversion is from the Owens River and various streams are added as we proceed with the canal to the floor of the Valley. The first twenty miles of the canal will be practically an open ditch, just as it would be in the floor of the Valley, and is practically a modified river channel. The reason that work is done in that way is because the water

plane in this Valley is within a few feet of the surface of the ground, and the canal will gain in flow rather than lose by seepage in those first twenty miles, and in the next place, because it would be exceedingly difficult and expensive to put a concrete lining in that saturated ground. The dredge used there is operated by electric power from our own hydro electric plants, which have been built for construction purposes. The canal there is being built by the city at a cost of about 55 cents a running foot, 35 feet wide.

The floor of Owens Valley, as we have proven, is a great artesian basin, so that, in addition to the natural flow of the streams which we can obtain, and also the storage which we expect to utilize, we have an artesian basin which has already been demonstrated to be from 50 to 60 miles long, and which we think in all probability is twice that long. We expect to utilize these artesian areas to supplement the stream flow particularly during seasons of extreme drought.

The city of Los Angeles owns about 80,000 acres of land in Owens Valley, an area twice as large as Catalina Island. Every acre has been bought at the seller's price, and we have not condemned an acre in the Valley.

We have also used a hydraulic suction dredge in our work there, although we find that the first one illustrated, the dipper dredge, is the most economical of the two, and we have now discontinued the hydraulic dredge.

One of our most serious problems was the transportation problem, in connection with the building of this aqueduct. We had to deal with a desert for the greater portion of the aqueduct, a place which had no railroad, and no water supply, no telephone, practically no postoffice,—practically nothing but a

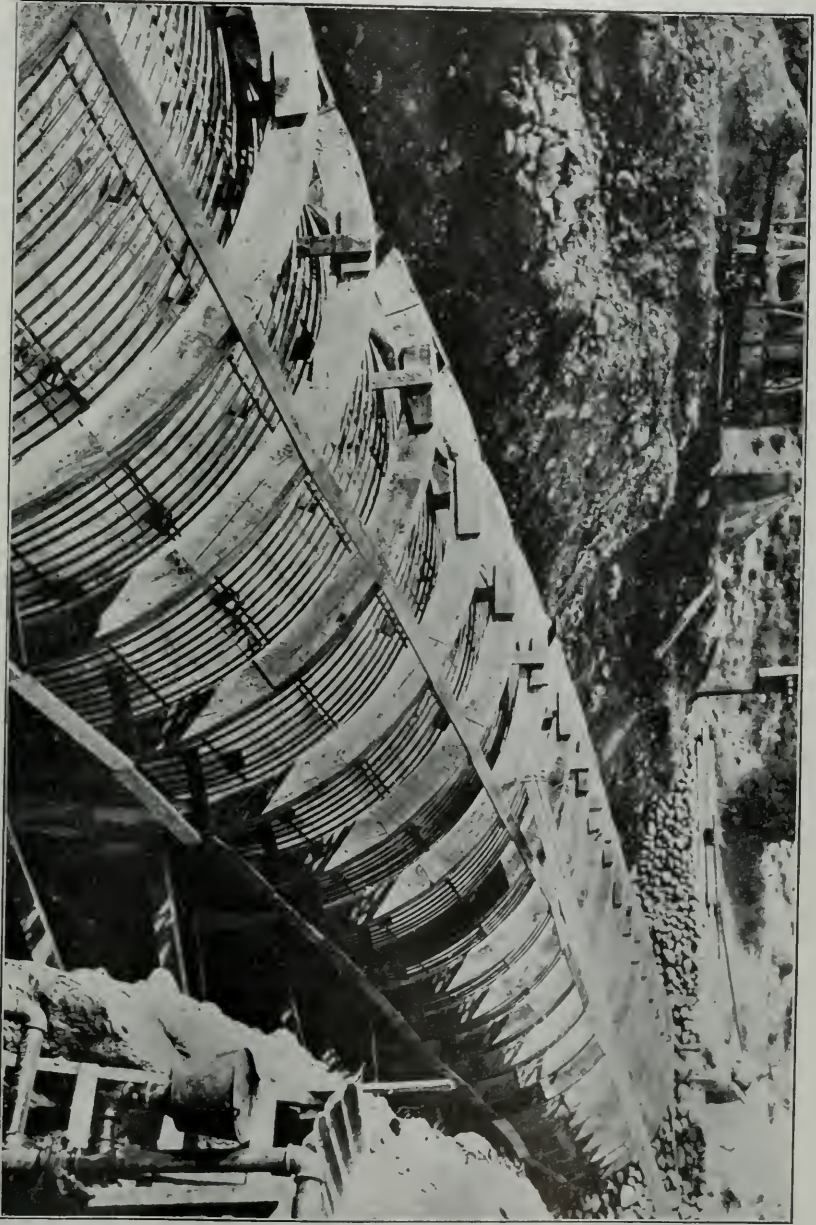

WHITNEY SIPHON, SAUGUS DIVISION, DIAMETER 10 FEET

desert. The first thing we had to do was to get the best of the desert. It was 140 miles from Mojave to Independence. While the aqueduct starts out in an open plain, it has many miles of its course in a rough mountain region. That is indicated by the fact that out of the 217 miles of aqueduct proper, there will be 43 miles of tunnels. Beginning with transportation by teams, we then reached the point where we used what we called a caterpillar type of traction engine, and that we used for hauling materials up roads which we had to construct ourselves. I suppose we built 150 miles of wagon road. We established a telephone system of over 200 'phones.

We have, by contract with the Southern Pacific Company, succeeded in getting a railroad built for the transportation of our freight from Mojave to Independence, parallel with the line of the aqueduct. In getting this railroad built, the Southern Pacific treated the city very handsomely. It was a case of their building a road for us, or our having to build a railroad for ourselves, and they built it and transported our freight for just about 50 per cent of what we could have done it for ourselves.

As illustrating the efficiency of the steam shovels which we have there, I will state that our original estimate on the work for the steam shovels was 40 cents a yard, while they are being handled by these shovels at from 15 to 17 cents a yard.

The first 60 miles of the canal it will have a carrying capacity of 900 cubic feet per second, or 45,000 miner's inches. That is above the reservoir site. Below that first reservoir site, after these flood waters are retained and smoothed out, as it were, the canal will have a capacity of 400 cubic feet per seconds, 20,000 miner's inches.

Another very interesting thing about the aqueduct is that we are doing all our work ourselves; that is, the engineers are the actual builders. Out of 217 miles of conduit, we have only contracted 11 miles of work—all the rest of it is being done, as we express it, by day labor or force account. We have built three hydroelectric power plants, a cement mill, operate 250 miles of telephone, are building all the conduit itself, have two railroads, and a great many other incidental pieces of work, all being done by the city and being done cheaply. I don't like to appear boastful over the matter, but we simply have proven beyond any question of doubt that the work is being handled in that manner a great deal more cheaply than it could be done by contract, and we have proved it because of the fact that we called for bids on the work, and we are doing the work for figures that are 25 per cent and 30 per cent less than the lowest bids that we got. I may say, in addition, that this work has been organized absolutely on a business basis. I think I know my organization as well as anybody connected with it, and there is not a political appointee on that entire aqueduct, from beginning to end, and we have about 3,000 men on the job. (Applause.)

We have found it necessary to use various kinds of hoists. We have the small cable hoist, we have the extensive hoists, and we have just the ordinary car track with a hoisting engine at the top of it that pulls up the ordinary little car—and that is the one that we like the best.

An interesting piece of work has been done at a point five or six hundred feet from the floor of the Valley, and where the tunnel is running in on a mountain which is granite, not of the hardest kind, but a good wholesome granite,



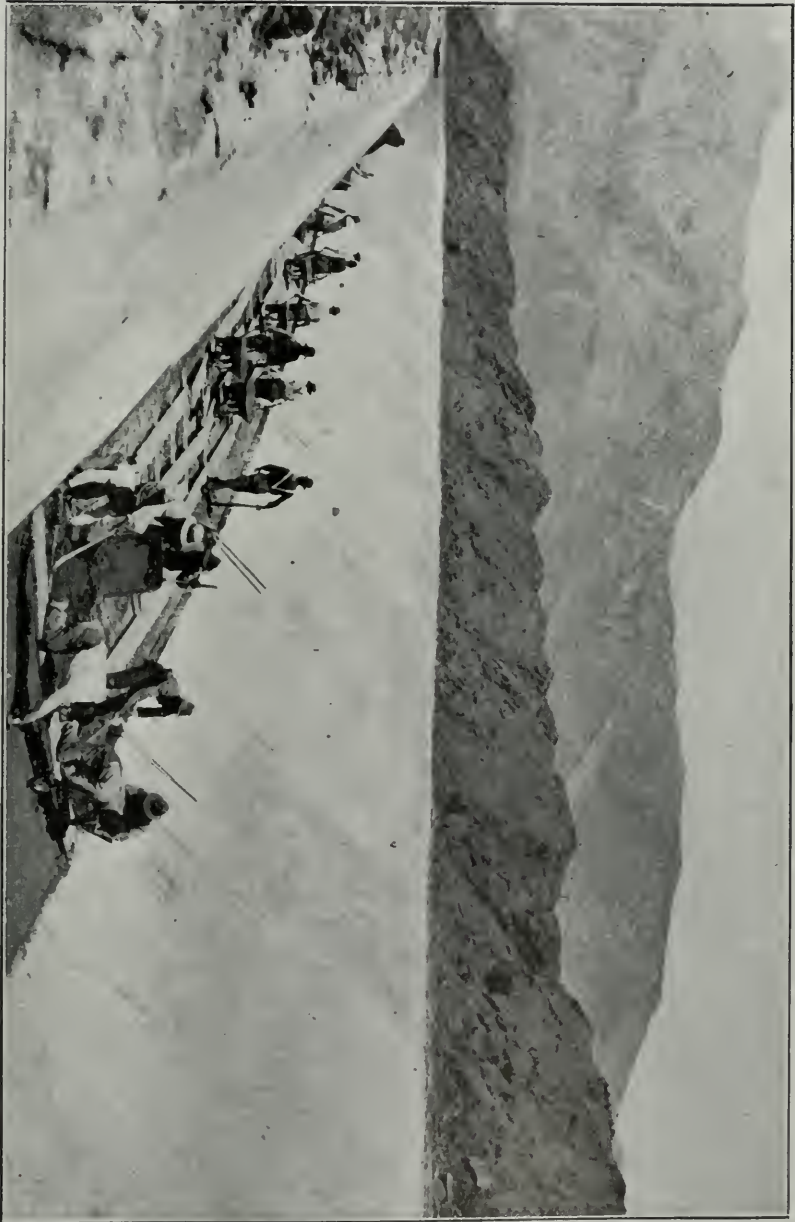

PUTTING THE BOTTOM IN THE CONDUIT, OLANCHA DIVISION—300 FEET A DAY

decomposed some at the surface, but good and hard down a few feet. Steam shovel work was saved in that same kind of rock by a liberal use of black powder, and, after shooting it off, following it up with the steam shovel. The result was that granite rock was excavated from the side of that mountain for 40 cents a yard.

There are whole divisions of the aqueduct where the mountainside is very steep, and inasmuch as we were going to build a great power plant in connection with the aqueduct, we were very anxious to have a line that would not be cut in half by rolling boulders. So literally for mile after mile along those mountain spaces, we did not come out to the surface at all, except that we made adits or entrances at right angles in to the line of the aqueduct. Those headings or adits are brought out perhaps every half mile from the aqueduct. We believed it was cheaper to run them to the line and then run the line entirely within the mountain, than to carry it out and across these canyons with bridges or flumes.

We have built over two hundred houses in the course of doing the work.

We have done our tunnel work by a system of co-operation with the miner.

We frankly go to every miner and say to him, "Now, in this tunnel you ought to make 8 feet a day, working three shifts. If you can beat that, why, we will divide the savings with you." That is, the cost per day for the labor and lights and most other things that go to make up the day's work is practically constant, so the greater average you can make in driving the tunnel, the cheaper the tunnel is per foot. So we have laid down that basis and divided the savings with the miners—anything that they can save over that basis. It has resulted in

some very great tunnel runs. We have been criticized for it, and they have said that our miners would chop the tunnels all to pieces, in order to make speed. But one of these pictures shows you how evenly and nicely the tunnel work actually has been done.

As to the hydroelectric plants which have been built in Owens Valley, the power is run along the line of the aqueduct for about 130 or 140 miles, and that power is available for all purposes, in running hoists and for any other purpose for which power may be desired, and also for lighting, and on the southern end of the line, we buy power from the Edison Company and run it along the southern half there. We also have the entire line, from one end to the other, piped for domestic water supply under pressure.

With the exception of the first twenty miles the entire aqueduct will be completely lined, and with the exception of the first sixty miles the entire aqueduct will be covered as well as lined. We are making practically all of the cement that we are using for the construction of the aqueduct.

One of the tunnels, the Elizabeth tunnel, is 23,800 feet between actual portals. All but about 1800 or 1900 feet of the work there is done, and we are about a year ahead of our schedule time on it.

Referring to our cement plant, I think it is probably the only municipal cement plant in the world. When we started in to build the aqueduct, cement was being sold in Los Angeles for about \$2.25 a barrel. We are turning it out from that mill now for about \$1.35 a barrel, and we get it when we want it.

The development of water-power is one of the main features of the aqueduct. We expect to develop a big power plant, about 90,000 horse-power. The

tunnels down in the portion of the line where we have to deal with the development of the power are very much larger than they are elsewhere, because we have a reservoir at the intake of the power system, and another reservoir at the foot of the power system, so that the flow of water through the power plants can be fluctuated from a small amount up to a thousand cubic feet per

second, which is two and a half times the normal flow of the ditch. That is one of the advantageous provisions that we have made.

I will close by showing you a picture of Mr. Mulholland, the chief engineer of the system, who deserves so much credit for his excellent work there, and thank you for your kind attention. (Applause.)



## SANITATION

BY F. H. OLMSTEAD OF LOS ANGELES

Mr. Chairman and Gentlemen of the Convention: There are only about three matters that I want to take up in a very short talk this afternoon.

When we speak of sanitation, we ordinarily and commonly think of an abundant and quick supply of pure water, pure air, and general cleanliness. There is no opportunity this afternoon of speaking from the engineer's standpoint of the appliances for sanitary engineering. But I do want to bring out two or three points that I would like your cooperation and help in.

One of them is the general lack of recognition on the surface of unpaid city officials, like city trustees. In my experience of something like twenty-two southwestern cities as a city engineer or a consulting engineer, sanitary engineer for the municipalities, I have frequently worked day after day and night after night with city trustees who unselfishly, without pay, were putting in the same hours. I was well paid for it, and they were not paid at all. With very few exceptions, I think our communities recognize the value of the service given by good men of the community, men who ordinarily are courteous

and of kindly feeling. You will find them criticised, which is all right, that is, when criticism is warranted, but you will very seldom find the hand and voice of approval granted those men. We owe it to the men who serve us to properly compensate them.

And another thing that I want each one of you to keep in mind during the next year is that it is so easy to criticize, it is so easy for the newspapers and the envious to give criticism, and yet that criticism, coming so easily, sometimes goes so far. This afternoon I heard a friend of mine criticized, a man who is not here to answer. I refer to Henry Dockweiler. He was city engineer of Los Angeles, and he has had a responsible position in San Francisco. Many, many times he could have sold Los Angeles out, and he could have done the same thing up there in the north. I feel that his career, if it is understood, will be an answer to any such criticism. So, let us all next year make it a point to give our public officials a boost.

Who has given Mr. Mason a boost here? I have watched the proceedings of this League for years, and he has



kept it up and kept it alive, and I think we owe him a great big vote of thanks because of the work he has done for us. Let us get into the habit of patting each other on the back when we deserve it.

Another thing: As to this Public Utilities Commission. As an advisory proposition, yes, by all means. We have the State Board of Health in California, and we are immeasurably indebted to it. But let our Public Service Commission be nothing arbitrary—no commission to make rates in some little town which is struggling better than anybody else can struggle with the proposition it has before it. The trustees of the little towns that are represented here today are better fitted to cope with the proposition than would outside experts be. But they can use expert advice, of course.

Another point is that, in the matter of the improvements that you are planning, it is just about to the extent that you carry those out that your success will be assured in the years to come. As a boy, I was raised in Chicago. At every meeting of the legislature in Springfield, it was a question of whether Chicago could raise her tax limit to bond herself for new improvements. That is pretty nearly true of Los Angeles, and to a small extent it is partially true of every one of your cities. The towns that do that, who put in efficient water systems, who put in good sewer systems, who carry out street work in the different sections of the town—it all comes back in the shape of additional wealth flowing into the banks, additional population—it all makes for a distinct advance. I thank you very much. (Applause.)

### EXPERT DOLGE MOVES

William Dolge, the expert municipal accountant, formerly located at 255 California Street, has increased his staff and moved to more commodious quarters at 311 California street, San Francisco.

### FINE WORK OF AUTO FIRE APPARATUS

A recent fire in the township of Malden, a suburb of Boston, brought out very forcibly the distinct advantage of motor driven fire apparatus over horse-drawn vehicles. Here time was the great factor in checking the blaze in its first and easiest stage, for as fire spreads in a compound ratio to time, a leeway of ten minutes would have placed it beyond control with a loss of thousands of dollars in property and also life.

In the case referred to an alarm was rung in from the very inflammable foreign quarter during the worst road conditions the town had ever experienced. The location of the fire alarm box was about equally distant from three fire houses, two of which were occupied by horse-drawn apparatus and the third by the Knox motor driven combination hose and chemical. The Knox car made the mile run to the fire, used the chemical stream and put it out before the first horse-drawn apparatus arrived, seven minutes after the auto reached the scene.

In speaking about the record run the fire chief said, "There was a high wind blowing that night and, knowing how inflammable those closely packed buildings always are, we would have had a very hard fight on our hands had the fire got a fair start in those extra seven minutes or more before the horse-drawn apparatus could be brought into play. The promptness of the Knox motor combination unquestionably saved a big property loss and several lives."

## EDITORIAL

### THE MUNICIPAL CONGRESS AND EXPOSITION AT CHICAGO

The plans for participation at the Chicago Municipal Congress and Exposition this coming September, as approved by the Executive Committee of the League, have been mailed to the different boards and city councils, but up to the present few replies have been received.

We are sorry that more interest is not manifested in this exposition. The authorities in Chicago are looking for a fine showing by the cities and towns of California. The League has been appointed their official representative for the Pacific Coast, and it would be a lamentable thing if our cities and towns did not make a creditable showing. It will be rather bad grace on our part to ignore this invitation from Chicago and then ask them to hold another International Municipal Congress and Exposition in San Francisco in 1915. That is part of the plan, but there may be some difficulty in carrying it out unless our municipalities take part at Chicago.

The League convention at San Diego adopted a resolution declaring "*that the municipalities represented are hereby pledged to make a proper exhibit.*" There was not a dissenting voice, yet the resolution apparently did not mean anything. We are pleased to say that all the other resolutions adopted at San Diego were carried out, including the automobile tax, public utilities commission, and the revision of the Vrooman Act. We should never pass resolutions unless we intend to carry them out. Therefore, we sincerely hope that every

city official reading this article will take the matter up and urge his council to act one way or the other on this matter. The idea of giving away beautiful souvenir books depicting the municipal achievements of our cities and towns was suggested by Secretary Mason. The ones such as we would like to get out would be quite expensive, it is true, but because of that they would be treasured and not thrown away. The stereopticon scheme is less expensive.

Remember however, you are not confined to these plans. We don't care how you participate so long as you make some kind of an appropriate exhibit in accord with the nature of the Exposition. Remember too, that every cent contributed for this purpose will be strictly accounted for and submitted to the Auditing Committee at the next convention at Santa Barbara.

We are pleased to announce that the California Development Board at our request have consented to take part in the Chicago Exposition and maintain a lecturer during the entire time. City officials will kindly take the matter up with the Secretary at once in order that we may notify the Chicago people how much space will be required.



### AFFILIATION WITH COUNTY OFFICIALS

Assistant Secretary Locke attended the convention of County Supervisors held at Napa, May 15 to 18, and submitted a proposition that the city and county officials hereafter hold their annual meetings at the same time and place. The supervisors are disposed to favor the idea providing it does not involve consolidation, which of course would be equally repugnant to the League.

There are many reasons why it would be of great advantage for the city officials and county officials to hold their meetings at the same time and place. Many questions, such as road and street construction, sanitation, tree planting, public buildings, etc., are of equal interest and importance to both classes of officials, and it would be easier to secure high class expert talent for such features of the program, men who would attend if the city and county officials were assembled in the same city, but who could not afford the time and expense of attending different meetings throughout the state, at different times and places.

Another thing, it would insure the holding of a far more elaborate exhibit of the machinery and supplies used by cities and counties, such as road rollers, scarifiers, fire engines, sprinklers, iron culverts, accounting systems, sanitary devices, etc. The dealers in these things would go to far greater lengths if they would be enabled to exhibit and demonstrate their wares to the city and county officials at one and the same time.

Besides this, the arrangement suggested would increase the strength of both organizations materially. Many other arguments may be offered in favor of the plan and there is absolutely nothing which may be said against it, provided however, it is distinctly understood and agreed that both organizations

otherwise retain their separate independence.

#### OIL, MACADAM ROADS

One of the principal talks delivered at the convention of county supervisors recently held in Napa, was made by A. E. Loder, Chief Engineer of the Los Angeles Highway Commission. Among other things he told how the Commission is expending the \$3,500,000 voted by the county, and described in detail the management of their quarries. He said their oiled roads are costing from \$10,000 to \$11,000 per mile and stand the wear of automobiles better than plain macadam; he stated further however, that he does not regard it as a permanent pavement.



#### WARREN BROTHERS PATENT SUSTAINED

In the February number of Pacific Municipalities there is a brief report of the decision of the U. S. Circuit Court in the case of Warren Brothers Company vs. City of New York. The validity of the Bitulithic Pavement Patent was the question involved, which was decided in favor of the Warren Brothers Company. The City of New York appealed this case, but the U. S. Circuit Court of Appeals, Second Circuit, recently rendered a decision strongly upholding the lower court and sustaining the validity of the patent.

## A. CARLISLE & CO.

### Stationers, Printers and Bookbinders

We specialize in Bonds, Steel Die, Lithographed or Printed, for Municipalities or Counties, and the Books and Forms required by all Municipal Officers.

251-253 Bush Street

San Francisco, Cal.



Phones { Pac. Kearny 168  
 { Home J 2941



Cable Address  
 GARRATT  
 Codes, ABC--4th Edition  
 Western Union  
 Liebers

# Bell and Brass Foundry Machine and Hydraulic Works

ENGINEERS SUPPLIES

## W. T. GARRATT & CO.

277-299 Fremont Street

SAN FRANCISCO

### QUESTIONS AND ANSWERS

This department is for the use of city officials only. City Attorneys or others who may dissent from any opinion or answers given, or who may be able to give additional information of value on the subject of any inquiry, are earnestly requested to write us at once in order that we may transmit such further information to the official making the inquiry.

Q. Can the president of the board of trustees of a city of the 6th class, vacate his chair, second a motion, and afterwards vote on the question?

ANS. There is nothing in parliamentary law forbidding such a thing, but it would be rather an unusual and irregular proceeding.

Q. An act of March 23, 1907, provides that the expense of making assessments under the Vrooman Act may be included in the incidental expenses and included in the assessment roll. What is the usual compensation and how is it provided for?

ANS. We do not know what is the usual compensation received for the work, but would suggest that you ascertain if possible the charges made in neighboring towns. You should present an itemized bill duly verified, specifying

the number of hours employed at so much per hour.

Q. What is the law regarding the charges of city engineer for establishing grades and setting stakes?

ANS. There are no charges established by law. The customary rates around the bay are \$10 per day for the engineer and use of his instruments, and about \$2.50 per day for his assistants.

Q. Sec. 13 of the "Local Improvement Act of 1901" provides that the first installment shall be paid at the time the agreement is made, and the others annually thereafter, one each year, at the time when the first installment of municipal taxes is payable. Now then, if the first installment is paid June 6, must the second installment be paid in the succeeding November, four months thereafter, when municipal taxes are due, or shall we wait another year?

ANS. Advise payment of the second installment at the succeeding November; this will make two payments within five months but it is the safest plan.

Q. May a municipality, by ordinance, forbid the maintenance of poultry yards within a prescribed area of the town?

ANS. An ordinance has been sustained which forbid the keeping of chickens "in the built up portion of the city." *People vs. Davis*, 78 N. Y. App. Div. 570.

We believe you could prohibit poultry yards, if you mean the keeping and raising of poultry in large numbers, but do not believe you could prohibit the keeping of a small number of chickens for strictly domestic purposes. Of course you can forbid the housing of chickens within a certain distance of residences.

The courts take cognizance of local conditions and customs in deciding these questions.

Q. Does Senate Bill No. 256 apply to vacancies on the board of trustees?

ANS. Yes, all election officers.

Q. There are two printing establishments in our city. Our board have advertised for bids for doing the cities advertising and job printing for the ensuing year, twice within the past month; the first bids received by the board were rejected and the second bids were not entirely satisfactory. The board particularly desires to award the *advertising* to a certain one of the bidding firms but this firm is a little higher in its bid.

Can the board legally award the contract for the cities advertising to the firm whom they consider best equipped and most *competent* to do the work and which has the largest circulation, or are we compelled to award the contract to the *lowest bidder* regardless of any preference the board may have in the matter.

I will say in connection with the matter that the bids for advertising received from both of the firms were considered to be very reasonable.

ANS. It has been construed under the law that you are obliged to award the contract to the lowest responsible bidder, regardless of any preference the Board may have in the matter as between the different firms bidding. You might stipulate conditions in the notice for bids which could only be complied with by the best equipped printers.

# EUREKA FIRE HOSE



We originated the **Seamless Rubber Lined Cotton Hose**, and manufacture the celebrated brands

## EUREKA      PARAGON      RED CROSS

four ply

three ply

two ply

Eureka Fire Hose bought sixteen years ago can be seen today in regular use in the fire departments of many cities, and in the inflammable paint and dry goods districts.

The only circular and seamless woven fire hose made.

All sizes for every possible use.

### Eureka Fire Hose Mfg. Co., New York

610 Postal Telegraph Building

SAN FRANCISCO

# Wainwright Galvanized Steel Corner Bar

For Protecting Edges of Concrete Curbs, Steps, Columns, Etc.

The only effective **Concrete Edge Protector** offered to the contracting public  
 WAINWRIGHT PATENTS—March 9, 1897. November 22, 1898. May 5, 1903.  
 March 26, 1907. August 29, 1907. August 2, 1910.

This bar has been in public use for more than ten years as the main feature of the

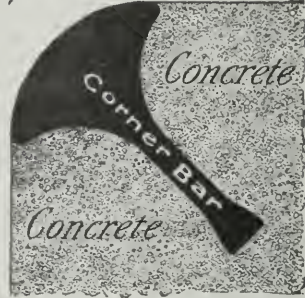

## WAINWRIGHT STEEL-BOUND CONCRETE CURB

THE BEST IN THE WORLD

OVER THREE MILLION FEET

In use in more than three hundred cities in the United States

Absolutely Non-Breakable  
 Cheaper Than Granite

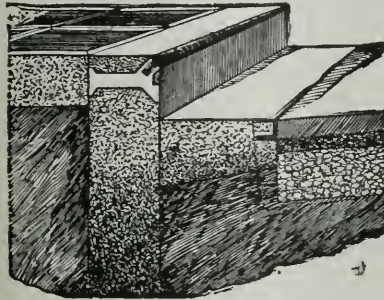

Handsome than Granite and much stronger.  
 Continuous in Construction, hence Never Out of Line.  
**GALVANIZED STEEL CORNER BAR** Prevents Chipping or Breaking on Edges.

This Curb is Mechanically Perfect and Unequaled for Curved Corners.

**THIS CURB WILL STAND HARDER USE AND LAST TEN TIMES AS LONG AS PLAIN CONCRETE CURBING.**

Contractors can make money by laying this curb.

City Engineers can save money by specifying it.

Architects are invited to read pages 242 and 243 "Sweet's Index."

Metal Parts for Sale. Send for Copyrighted Booklet No. 19.

**STEEL PROTECTED CONCRETE CO.**

REAL ESTATE TRUST BUILDING  
 PHILADELPHIA, PA.

In view of the fact, however, that both bids differ but little in price you could award the contract for advertising public notices in one paper, and award the other printer the contract for doing the book and job work. If you are satisfied that both printers are trustworthy and desire to do the right thing, this last suggestion is well worth considering and is the policy followed in many places.

Q. Could you tell me of any City in California that has adopted an ordinance compelling telephone, telegraph and electric light companies to place their wires in conduits underground in the principal streets? I would like to obtain a copy of the ordinance if possible.

ANS. Enclosed you will find three ordinances covering this matter.

Q. Is there any question as to the validity of Section 4460 of the Political Code defining a newspaper of general circulation?

What is the latest discussion on this question?

ANS. On January 6, 1910, in the matter of the application of the Devlin & Judah Company for a decree declaring the Santa Cruz Evening News to be a newspaper of general circulation as that term is defined by Section 4460 of the Political Code, the Appellate Court decided against the newspaper on the ground that it had not been established and published for a period of one year. The Court declined to pass on the constitutionality of the Section.

The petition for a rehearing was denied on February 3, 1910, and a subsequent petition to have the matter heard in the Supreme Court was denied on March 7, 1910.

The only way to have the constitutionality of this matter determined is by summary proceeding such as a writ of mandate.



## What the Cities are Doing

**Rio Vista** is preparing to install a sewer system.

**Sacramento** has purchased a 12 ton Iroquois road roller.

**Antioch** is planning some elaborate street improvements.

**San Anselmo** is having a ten-box fire alarm system installed.

**Sonoma** will start the construction of its sewer system at once.

**Selma** trustees are enforcing the construction of a lot of cement sidewalks.

**Healdsburg** trustees are making extensions to their municipal water system.

**Richmond** has commenced a large amount of street work under the new law.

**Santa Barbara** just ordered the construction of seven blocks of asphalt pavement.

**Antioch** is about to start considerable street work under the new improvement act.

**Santa Barbara.** The county supervisors will pave the streets around the Court House.

**Concord** is installing its sewer system for which \$29,000 bonds were recently voted.

**Fresno** officials have started a movement for the acquisition of a municipal water plant.

**Sacramento** on June 9 will vote on the proposition of a \$800,000 bond issue for schools.

**Pasadena** will receive bids on June 6 for a turbine engine for its municipal lighting plant.

**Ross** has installed a non-interfering fire alarm system, including twenty alarm boxes.

**Santa Ana** is advertising for a small automobile to haul material and supplies for the city.

**Tracy** has started bond proceedings for the construction of a water plant and also a sewer system.

**Hayward** is about to replace its old High School building with a new one to cost about \$40,000.

**Dixon** voted \$40,000 bonds for a sewer system on May 2nd. The vote was 183 for and 30 against.

**Porterville** has received the Seagrave motor driven hose wagon recently purchased by the trustees.

**St. Helena** voted on the question of issuing \$30,000 bonds for a new High School Building, on May 22.

**Oakland** has just purchased two Seagrave Motor driven combination chemical and hose wagons.

**Oakland** citizens have decided by a large majority to spend \$1,755,900 for additional school facilities.

**Redding** has just received the Seagrave combination chemical and hose wagon recently ordered.

**Chino** citizens voted \$40,000 bonds for a municipal water plant, on May 8. The vote was 178 to 40.

**Fullerton** is contemplating the issuance of \$192,000 bonds for street pavements and concrete bridges.

**Sacramento** trustees will purchase an automatic ariel truck mounted on an automobile for their fire department.

**Berkeley** has received the Seagrave Motor—propelled combination chemical and hose wagon recently ordered.

**Orange** voted on May 27th on the proposition to issue \$25,000 bonds for domestic science and polytechnic buildings.

**Redwood City** is installing a fire alarm system, comprising 20 non-interfering boxes and a whistle blowing mechanism.

**Modesto** has let the contract for the installation of a non-interfering fire alarm system to include twenty alarm boxes.

**Orland** voted \$25,000 for a water works and \$25,000 for a sewer system, on May 1. The bonds were carried by a vote of 123 to 3.

**Sonoma** has received word from Andrew Carnegie that he will donate \$6000 toward the construction of a free public library.

**Pasadena** has awarded a contract to the Barber Asphalt Company for paving Orange Grove Avenue with bitulithic pavement.

**Anaheim** fire laddies have been granted additional apparatus by the trustees consisting of 1000 feet of hose and an extension ladder.

**Glendora** citizens, assembled in mass meeting, have resolved on a \$50,000 bond issue for a 12-room fire-proof grammar school building.

**Merced.** The El Capitan Hose Company has recommended the installation of 17 new fire hydrants and the standardizing of old ones.

**Mill Valley and Sausalito,** comprising the major portion of the Tamalpais Union High School District, voted \$35,000 bonds on April 29.

**Riverside.** The state architects are understood to be preparing plans for the construction of the \$150,000 Normal School at Hawley Heights.

**Fairfield.** The supervisors of Solano County will receive bids on June 5th for furnishing the new Court House under construction here.

**San Bernardino** school authorities are calling for bids for new machinery and equipments for the technical department of the High School.

**San Mateo** is about to commence the construction of the various municipal improvements for which a large bond issue was recently voted.

**Chico** trustees have ordered plans and specifications for the construction of a large fire cistern near the State Normal and Training School.

**Nevada City.** The proposition to bond the High School District for \$30,000 for a new High School Building was carried on April 25 by a vote of 262 to 116.

**Los Angeles** needs more schools. On June 6 there will be a special election on the question of issuing \$1,720,000 bonds for new buildings and repairs.

**San Jose** has commenced bond proceedings for more sewers, a garbage incinerator, additional fire fighting apparatus, bridges and an extension of the fire alarm system.

**Redwood City** is commencing a lot of street improvements to be done under the "Local Improvement Act of 1901." It is estimated the work will cost \$73,670.95.

**Oakland** citizens have re-elected Mayor Frank K. Mott by a safe majority over the socialist candidate. Mayor Mott will be the first executive under Oakland's new charter.

**Mountain View** is conducting street work proceedings under the new improvement law drawn by the League attorneys. A local bank has offered to take the bonds for six per cent.

**Anaheim.** By a vote of 277 to 61, the Union High School District voted \$100,000 bonds on May 1, for a magnificent high school building to be located at the corner of Center and Citron streets.

**Vallejo** is advertising for bids for the construction of a new reservoir in connection with its municipal water works; it will have a capacity of about 13 million gallons and cost about \$35,000.

**Willows** trustees have received the completed plans for their new City Hall—a mission style structure. It will cost \$25,000 and will contain a court room, city jail, and rooms for the fire department.

**Alhambra** invited bids to be submitted May 20 for supplying 2400 tons of crushed rock. It was required that the rock retain 75 per cent of its weight after testing for three hours in a standard rattler.

**Willows** The Greater Willows Promotion Association have requested a resubmission of the question of issuing \$50,000 bond for a new High School. The proposition was recently defeated by a narrow margin.

**Ventura.** The county courthouse about to be constructed here will be one of the most imposing building in California. The general style is to be Roman Doric and the buildings and furnishings will cost \$250,000.

**Alameda** will shortly vote on the proposition to issue \$125,000 bonds for improvements to the municipal electric lighting plant, \$75,000 to improve the fire alarm system, and \$16,000 for bath houses and park improvements.

**Santa Barbara** property owners on Pedregosa street have petitioned for the construction of a 7-inch granite macadam pavement, with stone gutters and curbs, and steel topped culverts. This will make a most substantial and durable pavement and will cost about \$10 a running foot.

**San Francisco** is framing a new improvement act for the construction of several tunnels. Mr. H. A. Mason, Secretary of the League, has the work in charge. The Local Improvement Act of 1901 is being used as a basis, as it is desired that a portion of the cost be paid in advance and a waiver be secured from the property owners as to the validity of the proceedings.

## LIST OF RESPONSIBLE FIRMS TO BE CALLED ON TO BID FOR PUBLIC WORK OR SUPPLIES

### WRITE FOR CATALOGS

This list is arranged as a guide for the accommodation of city officials where advertising for bids is not necessary.

#### Accountant

William Dolge, C. P. A., 311 California St., S. F.

#### Architects

W. H. Weeks, 251 Kearney St., S. F.

#### Asphalt Machinery

J. I. Case Thresh'g Mch Co. 616 Myrtle St. O'kl'nd  
A. L. Young M'chy Co. 26-28 Fremont St., S. F.  
Barber Asphalt Paving Co., S. F. & L. A.

#### Arch. Terra Cotta

Gladding, McBean & Co., Crocker Bldg, S. F.  
Steiger Terra Cotta & Pottery Wks, 729 Mills  
Bldg., S. F.

#### Automobile Public Service Wagons

The Thomas B. Jeffery Co., 117-125 Valencia  
St., S. F.  
Reliance Auto. Co., 342 Van Ness Ave., S. F.  
American La France Fire Eng. Co., 660 Mission  
St., S. F.

#### Bells

W. T. Garratt & Co., 277-279 Fremont St, S. F.

#### Bitulithic Pavement

Warren Brothers Company, Los Angeles, Cal.

#### Blue Prints

So. Cal. Blue Print & Supply Co., 800 L. A.  
Trust Bldg., Los Angeles.

#### Bridge Builders

E. T. Thurston, Jr., Wells, Fargo Bldg., S. F.

#### Concrete Construction

Esterly Con. Co., Inc., 717 Market St., S. F.

#### Concrete Mixers

California Hydraulic Eng. & Supply Co.,  
S. F. and Los Angeles

#### Constructing Engineers

Fred'k C. Roberts & Co., 221 Sheldon Bldg, S. F.  
Cal. Hydraulic Engineering & Supply Co.,  
San Francisco and Los Angeles  
Geo. E. Dow Pumping Engine Co, S. F. & L. A.

#### Consulting Engineers

Sloan & Robson, Nevada Bank Bldg., S. F.  
E. T. Thurston, Jr., Wells Fargo Bldg., S. F.  
American Engineering Corporation, 57 Post  
St., S. F.

#### Culverts

Cal. Corrugated Culvert Co., Los Angeles and  
W. Berkeley

#### Dump Carts and Wagons

J. I. Case Thresh'g Mch Co. 616 Myrtle St. O'kl'nd  
A. L. Young M'chy Co., 26-28 Fremont St., S. F.  
Watson Wagon Co., Canastota, N. Y.

#### Electrical Plants & Machinery

A. L. Young M'chy Co., Fremont St., S. F.

#### Engravers and Bond Printers

A. Carlisle & Co., 251 Bush St., S. F.  
Schmidt Lith. Co., Second & Bryant Sts., S. F.  
Sierra Art Eng. Co., Front & Com. Sts., S. F.

#### Engineers' Supplies

W. T. Garratt & Co., 277-279 Fremont St, S. F.

#### Fire Engines

Gorham Eng & Fire App Co., 48 Fremont St  
S. F.  
Squires & Byrne Co., 565-567 Mission St., S. F.  
Pacific Fire Extinguisher Co., 507 Montgom-  
ery St., S. F.

#### Fire Hose

Gorham Eng & Fire App Co., 48 Fremont St  
S. F.  
New York Belting & Packing Co., 129-131  
First St., S. F.  
The Gutta Percha & Rubber Mfg. Co., 34  
Fremont St., S. F.  
The Diamond Rubber Co.  
Eureka Fire Hose Mfg. Co., 610 Postal Tele-  
graph Bldg., S. F.  
Squires & Byrne Co., 565-567 Mission St., S. F.

#### Fire Pumps

Geo. E. Dow Pumping Engine Co, S. F. & L. A.

#### Gasoline Engines

Cal. Hydraulic Eng. & Supply Co. S. F. and  
Los Angeles

#### Machine Works

W. T. Garratt & Co., 227-229 Fremont St, S. F.

#### Municipal Accountant

William Dolge, C. P. A., 311 California St., S. F.

#### Municipal Castings

Geo. E. Dow Pumping Engine Co, S. F. & L. A.

#### Municipal Printers

A. Carlisle & Co., 251-253 Bush St., S. F.

#### Municipal Engineers

Fredk. C. Roberts & Co., 461 Market St., S. F.  
Sloan & Robson, Nevada Bank Bldg, S. F.

#### Municipal Lighting Plants

Fredk. C. Roberts & Co., 461 Market St. S. F.

#### Municipal Water Works

Fredk. C. Roberts & Co., 461 Market St., S. F.  
Geo. E. Dow Pumping Engine Co, S. F. & L. A.

#### Office Furniture

H. S. Crocker Co., 674 Mission St.



**LIST OF RESPONSIBLE FIRMS—Continued**

**Pavement Materials**

Barber Asphalt Paving Co., S.F. and L. A.  
Warren Brothers Company, Los Angeles, Cal.

**Pumping Machinery & Supplies**

California Hydraulic Eng. & Supply Co., San Francisco & Los Angeles  
W. T. Garratt & Co., 277-279 Fremont St., S.F.  
Pacific Fire Extinguisher Co., 507 Montgomery St., S. F.  
Geo. E. Dow Pumping Engine Co, S.F. & L.A.

**Playground Apparatus**

A. L. Young Machinery Co., S. F.

**Riggers**

C. A. Blume Con. Co., 185 Stevenson St., S.F.

**Road Machinery**

J. I. Case Threshing Mch. Co., 616 Myrtle St., Oakland, Cal.  
The Good Roads Mach'y Co., Ft. Wayne, Ind.  
A. L. Young M'chy Co., Fremont St., S. F.  
Petrolithic Co., 345 P. E. Bldg., L. A.  
Barber Asphalt Paving Co., S. F. & L. A.

**Roofing**

Barber Asphalt Paving Co., S. F. and L. A.

**Rubber Goods**

Squires & Byrne Co., 565-567 Mission St., S.F.  
The Diamond Rubber Co.

**Sanitary Wiping Rags**

The Raychester Co., 1448 Folsom St., S. F.

**Scrapers**

J. I. Case Thresh'g Mch Co. 616 Myrtle St. O'kl'nd  
A. L. Young M'chy Co., Fremont St., S. F.  
Petrolithic Co., 345 P. E. Bldg., L. A.

**Sewage Pumps**

Geo. E. Dow Pumping Engine Co, S.F. & L. A.

**Sewer (Concrete)**

Esterly Con. Co., Inc., 717 Market St., S.F.

**Sewer Pipe and Terra Cotta**

Gladding, McBean & Co., Crocker B'ldg, S. F.  
Steiger Terra Cotta Co., Mills B'ldg., S. F.

**Sewer Systems**

Sloan & Robson, Nevada Bank Bldg., S. F.

**Sidewalks (Cement)**

Esterly Con. Co., Inc., 717 Market St., S. F.  
Steel Protected Concrete Co., Phila., Pa.

**Street Signs**

A. L. Young Mch. Co., S. F.

**Street Sweepers**

A. L. Young M'chy Co., Fremont St., S. F.

**Structural Steel Erectors**

C. A. Blume Con. Co., 185 Stevenson St., S.F.

**Water Works Equipment**

California Hydraulic Eng. & Supply Co., San Francisco and Los Angeles  
Geo. E. Dow Pumping Engine Co, S.F. & L.A.

Insulated Wires and Cables

Wire Cloth and Netting

**John A. Roebling's Sons Co.**

S. V. MOONEY, Manager  
MANUFACTURERS OF

**Iron, Steel and Copper Wire Rope and Wire  
of every description**

Phones, Kearny 2426; Home J1220

624-646 Folsom Street

**SAN FRANCISCO**

Works at Trenton, N. J., and Roebling, N. J.

**SQUIRES & BYRNE CO.**

565-567 Mission St., San Francisco

Dealers in all kinds of

**Double Jacket Fire Hose**

for department uses. Underwriters Linen Hose, Fire Hose Carts and Jumpers. Extinguishers and equipments for Fire Departments, also a full line of mechanical rubber goods of every description. Write for discounts and prices.

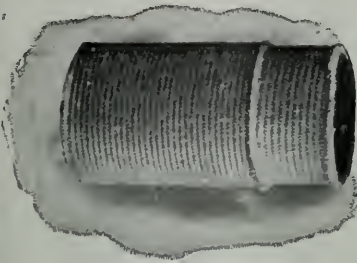

# Worswick Street Paving Company



**GENERAL CONTRACTOR**

**Sheet Asphalt, Macadam,  
Asphalt Concrete, Cement  
Concrete Constructions**

**Dealer in  
Asphalt, Crushed Rock  
Gravel and Sand**



**Main Office, Rooms 5, 8, 9, Union National Bank Building**

**Phone Main 1434**

**Cable Address "Worswick"  
Western Union Universal Code**

**Fresno, California**





Trinidad Lake, showing asphalt dug for Genasco Ready Roofing.

# Genasco Ready Roofing

Made of real Trinidad Lake asphalt—the water-proofing made by Nature. It has resisted storms for hundreds of years. Oughtn't that to be good for roofs?

It makes Genasco last longer than any other roofing of any other substance.

Write for samples and the Good Roof Guide Book. Mineral and smooth surface. Insist on Genasco—the roofing with a thirty-two-million-dollar guarantee. Look for the hemisphere trademark.



THE BARBER ASPHALT PAVING COMPANY

Largest producers of asphalt, and largest manufacturers of ready roofing in the world.

PHILADELPHIA

New York

San Francisco

Chicago



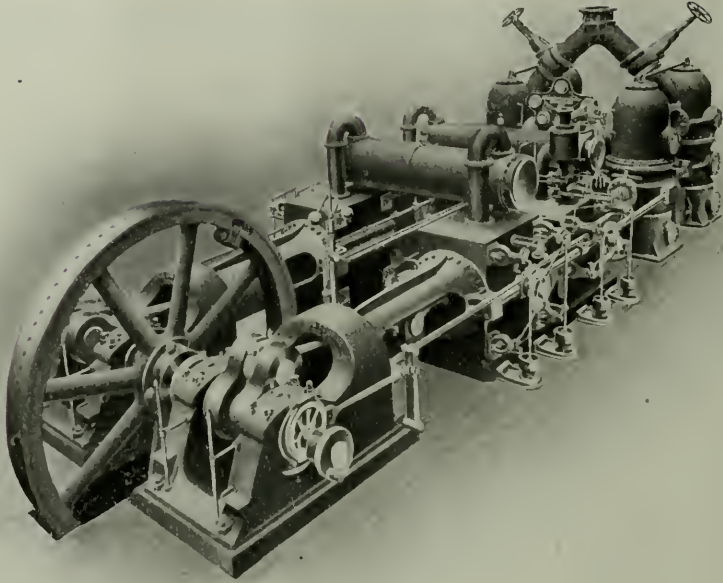

## FOR THIRTY-SEVEN YEARS

We have taken the responsibility of  
installing water works pumps  
for cities and towns.

No one understands the grave responsibilities assumed in selecting  
pumping machinery better than you

### The Trustees and Engineers Of the Cities and Towns of California.

The health and life of your fellow citizens frequently, and the saving  
of property from fire always, depends on the reliability of the city  
pumping plant.

*Our experience and the assistance of our engineers are at your service.  
Write us regarding any question of water supply. We will gladly assist you.*

## GEO. E. DOW PUMPING ENGINE CO.

237 S. Los Angeles St.  
Los Angeles

415 Sheldon Building  
San Francisco

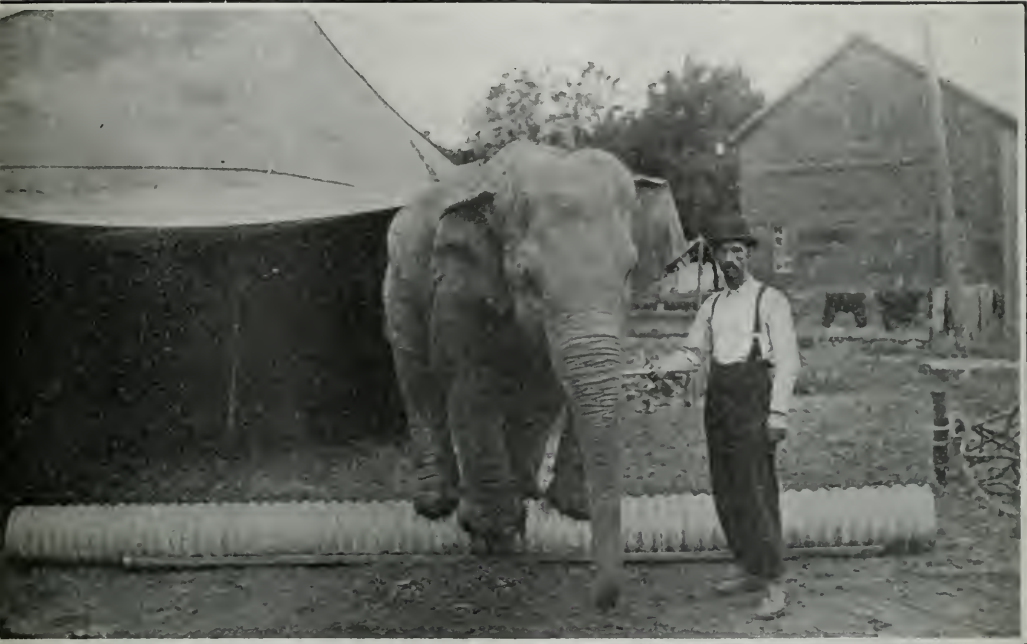

The wonderful intelligence of the elephant is no more clearly shown than his careful selection of a secure footing. He will not trust his great weight on weak structures.

## American Ingot Iron Culverts have the strength to carry the greatest loads.

The corrugations make them 29 times as strong as plain pipe of the same weight material. They are the lightest and most easily handled. They will last a lifetime because

They are made of American Ingot Iron 99.94% Pure.

"The purer the iron, the greater its resistance to corrosion."

### Let Us Demonstrate These Facts to You

---

**California Corrugated Culvert Company**  
Los Angeles, Cal. West Berkeley, Cal.

# International Municipal Congress and Exposition

Chicago, Ill., U. S. A., September 18 to 30, 1911

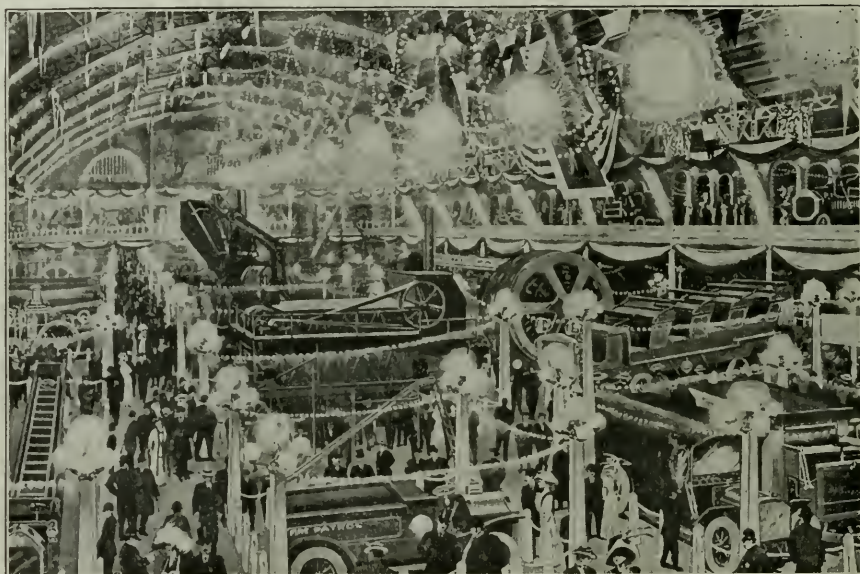

**T**HE CONGRESS will be participated in by Municipal Officials and duly appointed delegates from all of the principal cities of America and Foreign Lands, together with the members of National and International organized bodies concerned in any particular branch of civic work or in clean, economic municipal government as a whole. The world's brightest as well as practical minds will deliver to the Congress papers bearing on that special line of municipal undertaking which they have made their respective studies for a lifetime.

**T**HE EXPOSITION will comprise not only municipal exhibits of every variety, but also the works of the great inventors and manufacturers of the world, who are manufacturing and providing municipal supplies for the universe.

#### Local Forces Participating

The City of Chicago	Civic Federation of Chicago
Chicago Association of Commerce	City Club of Chicago
Citizen's Association of Chicago	United Charities of Chicago
Industrial Club of Chicago	Rotary Club of Chicago

#### Full Information Upon Application to Either of the Undersigned

JOHN M. EWEN, Chairman	CURT M. TREAT, Secretary
JOHN MAC VICAR, Commissioner General of Congress	
EDWARD H. ALLEN, General Manager of Exposition	

1107 Great Northern Building

CHICAGO, ILLINOIS

Or to their Pacific Coast Representatives:

League of California Municipalities, Pacific Building, San Francisco, Cal.



# Desks, Chairs, Tables and the celebrated Globe-Wernicke Elastic Bookcases and Filing Cabinets

We carry the most complete line on the Pacific Coast.

Send for Catalogs

## H. S. CROCKER & CO.

674. Mission Street

San Francisco

TERRA COTTA, PRESSED BRICK, PIPE,  
FIRE PROOFING, ROOFING TILE,  
FLUE LININGS, FIRE TILE,  
LAUNDRY TRAYS,  
ETC.

**GLADDING, McBEAN & CO.** ↗

WORKS  
LINCOLN, CAL.  
--- OFFICE ---  
311-317 CROCKER BLDG., SAN FRANCISCO.

# Steiger Terra Cotta and Pottery Works

MAIN OFFICE AND YARDS:

City Yard, 18th and Division Streets

Main Office: 729 Mills Building

Phone Douglas 3010

SAN FRANCISCO, CAL.

Factory, South San Francisco  
San Mateo County

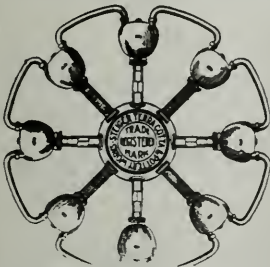

Fire Apparatus  
Police Patrols  
Ambulances

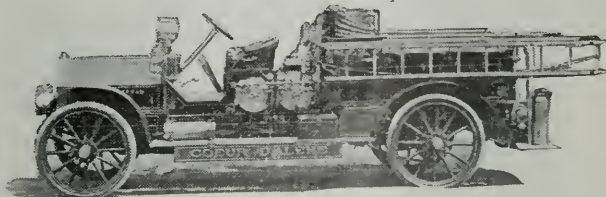

REPRESENTED BY

## RELIANCE AUTOMOBILE CO.

342-352 Van Ness Ave.

SAN FRANCISCO

## California Hydraulic Engineering & Supply Co.

### Constructing Engineers

Complete Pumping Plants for City, Fire and Irrigating Systems  
Gasoline Engines, Centrifugal and Deep Well Pumps  
Motors, Concrete Mixers and Supplies

70 Fremont Street  
San Francisco

341 South Los Angeles Street  
Los Angeles



### BUILDING GOOD ROADS

is work that counts. To do this work economically you need a **Fort Wayne Mounted Rock Crusher** with Elevator, Screen and Portable Bin.

**Efficient, Serviceable and Convenient**  
Built in several sizes

Send for catalog of Crushers, Dump Wagons, Road Graders, Steam Rollers, Sprinklers, Sweepers—Everything for Building Roads and Streets.

**The GOOD ROADS MACHINERY COMPANY, Fort Wayne, Ind.**  
Coast Representative, A. L. Young Machinery Co., San Francisco, Cal.

## PACIFIC FIRE EXTINGUISHER CO. ENGINEERS and CONTRACTORS

Pumping Plants, Hydrant Systems, Municipal Water Works, Hose and Ladder Carts, Chemical Apparatus  
Municipal Fire Alarm Apparatus, Watchman Time Detector Apparatus.

Los Angeles  
1006 Union Trust Bldg.

San Francisco  
507 Montgomery St.

Seattle Portland  
Spokane

Men in Public Service should assist in the redemption of

## LIQUOR USERS

The man who keeps his nerve propped with liquor, who feels his prestige slipping from him and his business equilibrium gone, knows that he soon will be relegated to the ranks of the "has beens," and unless able to retrieve himself from the clutches of alcohol, there will soon be written over his dead career this epitaph: "He Might Have Been." In three days

**THE NEAL TREATMENT, without hypodermic injections,**

Will cure the drink habit perfectly by a harmless process and with most pleasing after-effect. **Positively no injury can result.** Institutes in all the larger commercial centers of the United States and Canada. **Business confidential.** Write or call for full information and reference.

### THE NEAL INSTITUTE

1409 Sutter St.

Phones Franklin 1098; Home S2674

San Francisco, Cal.

# FREDK. C. ROBERTS & CO.

(INCORPORATED)

## Mechanical and Electrical Engineers

MUNICIPAL WATER WORKS  
MUNICIPAL LIGHTING PLANTS  
POWER PLANT EQUIPMENTS

461 Market Street

San Francisco, Cal.

# FIRE HOSE

THE GUTTA PERCHA & RUBBER MFG. CO.

34 Fremont St., SAN FRANCISCO, CAL.

**E. T. THURSTON, JR.**

M. Am. Soc. C. E.

**Consulting Engineer**

713 Mechanics' Institute

Phones Sutter 1683 and C 2895 SAN FRANCISCO

### **Specialties**

Design and Supervision of Buildings, Bridges,  
Sewers, Water Works, Highways, etc.

### **Concrete Bridges**

Exclusive rights under patents of National  
Bridge Company, the largest in the world.

Estimates furnished free of charge.

## C. A. BLUME CONSTRUCTION CO.

Members of Builders Exchange

Structural Steel Erectors

Riggers

Phone Douglas 324  
185 STEVENSON STREET

SAN FRANCISCO

## ESTERLY CONSTRUCTION CO., Inc.

CONCRETE CONTRACTORS

Buildings, Bridges, Sidewalks, Walls, Floors, Foundations

Room 605, 717 Market St., San Francisco

2136 Center St., Berkeley



**M. Greenberg's Sons,** 225 and 227 BEALE STREET  
Phone Kearny 276 San Francisco

FIRE HYDRANTS, COUPLINGS, ETC.

Manufacturers of Engineers' Findings, Plumbers', Steamship, Brewers' & Winery Brass Goods  
Brass and phosphor bronze castings; brass and iron work of every description made and repaired



**WILLIAM DOLGE***Certified Public Accountant --- Municipal Accountant*

TELEPHONE SUTTER 697

Insurance Bldg, 311 California Street

San Francisco, Cal.

**WM. H. WEEKS, Architect**PUBLIC BUILDINGS A SPECIALTY

251 Kearney Street

San Francisco

**SLOAN & ROBSON, Engineers**Reports, Designs, Estimates and Supervision of Municipal  
Light, Water and Sewer Systems

Telephone Kearney 4646

Nevada Bank Building, SAN FRANCISCO

**Create a Demand for YOUR BONDS***It Means Larger Premiums*Advertise them in **Coast Banker,** SAN FRAN-  
CISCO**AMERICAN ENGINEERING CORPORATION**

C. E. GRUNSKY, President

ALL BRANCHES OF ENGINEERING

Mechanics Institute Bldg.

SAN FRANCISCO

**THE CLARA BARTON****Sanitary Wiping Rags**

The Clara Barton Brand of Wiping Rags  
are Guaranteed to be thoroughly sterilized  
and disinfected. Telephone Market 2286

**The Raychester Co., Inc.**

1448-1460 FOLSOM ST., SAN FRANCISCO

# COUPLE REST WITH PLEASURE

by including the

## New Orleans-New York Steamship Line

Between New Orleans and New York in the routing of your ticket East. Costs less than an all-rail route and affords an interesting and delightful diversion on your trip.

### RATES

First class rail to New Orleans and First Cabin steamer to New York, \$	77.75
Round Trip	145.50
One way rail, one way steamer between New Orleans and New York,	70.00
Second class rail and second cabin New Orleans to New York,	65.75

RATES INCLUDE MEALS AND BERTH WHILE ON STEAMER

WRITE OR ASK ANY AGENT FOR DETAILS

# Southern Pacific

### TICKET OFFICES

Flood Building,  
Palace Hotel,  
32 Powell Street,  
Market Street Ferry Depot,  
Third and Townsend Streets Depot.  
Broadway and 13th Street, Oakland

## MECHANICAL RUBBER GOODS

FIRE HOSE  
Chemical  
Hose

EFFICIENCY  
Suction Hose  
Steam Hose

# Diamond

BELTING  
PACKING  
DURABILITY  
Water Hose  
Garden Hose

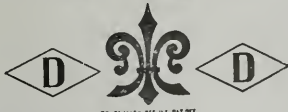

TRADE MARK REG. U.S. PAT. OFF.

THE DIAMOND RUBBER CO. of N. Y.

Cor. Second and Mission Sts., SAN FRANCISCO  
Factories, Akron, Ohio

# MUNICIPAL AND CONTRACTORS' MACHINERY

...FOR...

## GOOD ROADS AND STREETS

Street Signs

National Road Machines

Fort Wayne Road Machines

Indiana Road Machines

National Elevating Graders  
Elevators—Portable Bunkers

Shares or Cutting Edges for all types of Road Machines  
Rock Crushers, Jaw and Gyratory Type, mounted and  
unmounted

Screens

Steam Road Rollers

Horse Rollers

Scarifiers

Harrows for oiled roads

Wheeled and Drag Scrapers

Fresno Scrapers

Reversible Road Plows

Street Sprinklers

Sprinkling Attachments

Street Sweepers

Fibre for Street Sweepers

Watson Dump Wagons

Asphalt Machinery

Kettles—Hand Rollers—Tampers

Concrete Mixers

Hoisting Engines

Playground Apparatus

Culvert Pipe

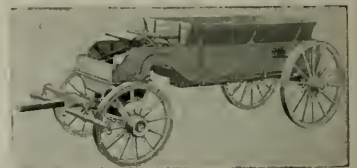
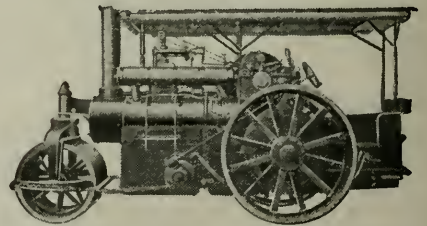

Write us for Catalogues and Estimates

## A. L. Young Machinery Co.

26-28 Fremont Street

San Francisco

California



# PACIFIC MUNICIPALITIES



WHAT  
OUR CITIES  
ARE  
DOING

PUBLIC  
SAFETY  
HEALTH  
CONVENIENCE

PUBLIC  
UTILITIES  
EDUCATION  
RECREATION

PUBLISHED MONTHLY

OFFICIAL ORGAN OF THE LEAGUE OF CALIFORNIA MUNICIPALITIES

**33 Seagrave Motor Propelled Fire Machines now in service on the Pacific Coast.  
21 more being built for this territory.**

There are good business reasons for the above remarkable showing, one is—We build nothing but F. D. Apparatus, and TO ORDER ONLY.

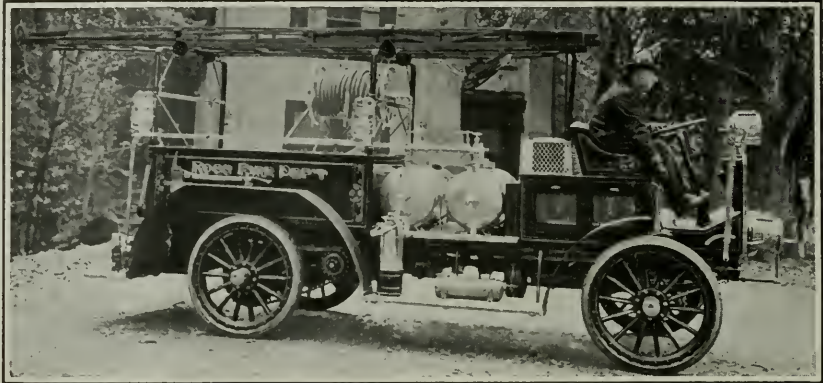

IN SERVICE AT ROSS, MARIN COUNTY, CAL.

Sold by **GORHAM ENGINEERING & FIRE APPARATUS CO.**

48 Fremont Street

San Francisco, Cal.

Branch Stores, Los Angeles, Cal.; Seattle, Wash.

SILENT

LUXURIOUS

3 MODELS

THE NEW  
*Rambler*

Touring Cars, Motor Fire Trucks, Chemical, Hose,  
Police Patrol and Ambulances a Specialty.

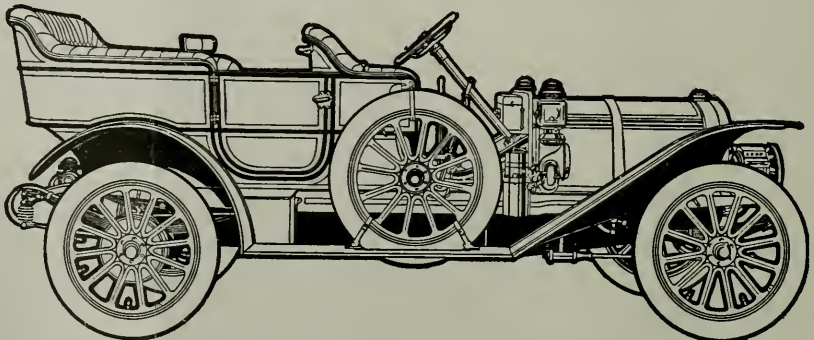

**The Thomas B. Jeffery Co.**

117-125 Valencia St.

WRITE FOR INFORMATION.

San Francisco



# "THE ROAD IS THE THING"

When built by the CASE Power-steered Road Roller

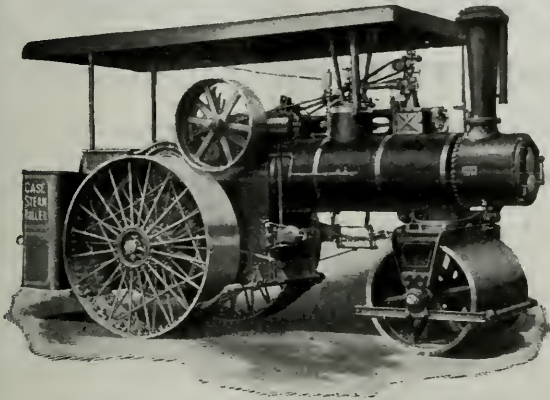

Power steering saves time over hand steering. Time saved is profit. The time saved in using a Case Roller and the extra work accomplished give increased profits to you, Mr. Contractor.

Write for Catalog on Road Roller, Road Machinery and Troy Dump Wagons and Boxes; for Contractors' General Purpose Engine and Municipal Catalog M. Address Road Machinery Dept.

Price, Simple Cylinder, \$2,200

6% discount for cash

J. I. CASE THRESHING MACHINE COMPANY, Inc. RACINE, WIS., U. S. A.

BRANCH OFFICE, 616 MYRTLE ST., OAKLAND, CAL.

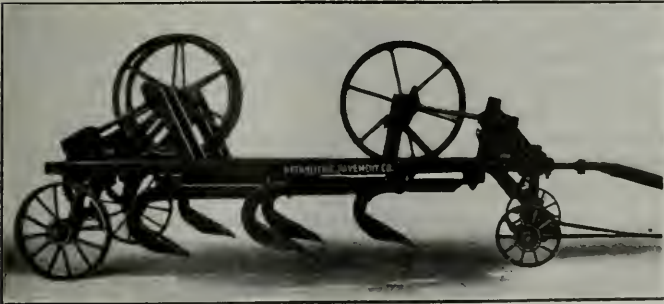

Let us tell you about the new

Petrolithic Gang Road Rooter and Scarifier

THE PETROLITHIC CO.  
345 P. E. Bldg.  
Los Angeles

Wherever good Contractors are,

there the Watson dump wagon is known. It's the most used dumping wagon in America, both by contractors and municipalities.



Only one single type of wagon is made in our big factory. All our time and money is devoted to doing one thing, and doing it well. Our printed matter is as high grade as the wagon. Ask for it.

WATSON WAGON COMPANY, Canastota, New York

The First Builders of Bottom Dumping Wagons

California Agencies: San Francisco, A. L. Young Machinery Co. 26-28 Fremont St.; Los Angeles, L. M. Davenport Co.



# “BITULITHIC”

## The Ideal Boulevard Pavement

### “BEST BY EVERY TEST”

☐ BITULITHIC has been adopted as the standard pavement in more than 200 cities, all of which give unqualified praise for BITULITHIC in the earliest as well as the latest cities. More than 15,000,000 square yards BITULITHIC PAVEMENT laid and contracted for in ten years, equal to over 850 miles of 30-foot roadway, shows the rapid increase of yardage and success of the BITULITHIC PAVEMENT.

☐ The following is one of many endorsements that shows that BITULITHIC is the most essential factor in real estate development:

315-316 Dickson Building,  
Norfolk, Virginia, May 7, 1910

Mr. George O. Tenney, Pres.,  
Atlantic Bitulithic Co., Richmond, Va.

Dear Sir:—

As per your request we are offering our opinion of the Bitulithic Pavement and its influence on the value of real estate.

We believe, from comparison with various kinds of paving, that it is the most durable and satisfactory, when constructed in a high grade manner. The Seventh Ward of our city has recently completed eleven miles of Bitulithic; a large expenditure, but justified by the increased tax return from the real estate. Real estate in this ward has increased twenty-five per cent. in value.

Very truly yours,

COLLINS & VAN DENBERGH, INC.

(Signed) Paul T. Collins, President.

☐ BITULITHIC affords a superior foothold for horses in either wet or dry weather and is a sanitary, non-skidding resilient street pavement.

☐ BITULITHIC beautifies the city and enhances the value of property more than any other form of pavement.

— Write today for explanatory booklets to —

## WARREN BROTHERS COMPANY

59 Temple Place, Boston, Mass. 616 Laughlin Bldg., Los Angeles

— (REGISTERED IN THE U. S. PATENT OFFICE) —

“Bitulithic” “Warrenite” “Bitustone” “Bitrock” “Puritan” “Rockphalt”  
“Bituminous Macadam”

NOTE—Every city official in California reads Pacific Municipalities.

# Pacific Municipalities

OFFICIAL ORGAN OF THE LEAGUE OF CALIFORNIA MUNICIPALITIES

Entered at Post Office, Santa Clara, Cal., as Second-Class Matter

VOL. XXIV

TWELFTH YEAR

No. 5

EDITORS	-	-	-	H. A. MASON AND WM. J. LOCKE
EDITORIAL OFFICE	-			NINTH FLOOR, PACIFIC BLD'G, SAN FRANCISCO
PUBLICATION OFFICE,	-	-	-	SANTA CLARA, CALIFORNIA

## CONTENTS FOR JUNE, 1911

Proceedings of the League of California Municipalities	181
Ground Squirrel Extermination as a Sanitary Measure	<i>Dr. Rupert Blue</i> 181
Oil Macadam Pavement	184
Regulating Public Utilities	185
Summing Up Results of the New Tax Law	<i>Hon. A. B. Nye</i> 188
The Audit of Municipal Accounts	<i>William Dolge, C. P. A.</i> 191
Trade Notes	192
The Sieben System of Sanitation for Cleaning and Disinfecting Sewers	193
Shy of Garbage	195
Typhoid Decreases	196
One Really Modern American City	196
On the Need of Research in the Manufacture of Asphalt from Cal. Petroleum	197
EDITORIAL	
The International Municipal Congress and Exposition at Chicago	198
Our Next Convention at Santa Barbara	198
The New Tax System a Success	198
Portland Considering Commission Plan	199
The Boston Smoke Law	199
Trade Notes	199
Questions and Answers	200
What the Cities Are Doing	203
Conducts Municipal Employment Agency With Success	204

Published Monthly. Yearly Subscription, \$2.00 in Advance. Single Copies, 25 Cents

ADVERTISING RATES ON APPLICATION

Address all Communications to "PACIFIC MUNICIPALITIES" Pacific Building  
San Francisco, California

# LEAGUE OF CALIFORNIA MUNICIPALITIES

Organized 1897

## — OFFICERS —

President	- - -	(Mayor of Berkeley)	-	BEVERLY L. HODGHEAD	
First Vice-President	- - -	(Councilman of San Diego)	- - -	A. E. DODSON	
Second Vice-President	- - -	(Mayor of Santa Cruz)	- - -	T. W. DRULLARD	
Secretary	-	H. A. MASON	Ass't Secretary	-	WM. J. LOCKE

## STANDING COMMITTEES

EXECUTIVE—	Beverly L. Hodghead; H. A. Mason; S. C. Evans, Mayor of Riverside; Percy V. Long, City Attorney San Francisco; W. P. Butcher, City Attorney Santa Barbara.
LEGISLATIVE—	W. F. Hyde, Palo Alto; J. O. Walsh, San Francisco; J. H. Strait, Redlands; F. H. Allbright, Red Bluff; B. L. Barney, Hanford.
JUDICIARY—	C. N. Kirkbride, San Mateo; P. G. Sheehy, Watsonville; Stephen G. Long, Long Beach; R. E. Rhodes, Madera; Wm. J. Carr, Pasadena.
ENGINEERING—	Chris. P. Jensen, Fresno; C. H. Pieper, San Jose; A. P. Noyes, Vallejo; R. C. Tumelty, Stockton; O. E. Stewart, Anaheim.

Secretary's Office and Headquarters of the League, - Pacific Building, San Francisco

## INFORMATION BUREAU

The League of California Municipalities maintains, in connection with the Secretary's Office, an Information Bureau where the officials of the municipalities belonging to the League can secure information on all subjects relating to municipal affairs.

## MEMBERSHIP

Alameda	Imperial	Rio Vista
Albany	Jackson	Riverside
Alhambra	Lakeport	Sacramento
Anaheim	Lemoore	San Bernardino
Antioch	Lindsay	San Buenaventura
Arcata	Livermore	San Diego
Azusa	Lodi	San Francisco
Bakersfield	Lompoc	San Jose
Benicia	Long Beach	San Leandro
Berkeley	Los Banos	San Luis Obispo
Biggs	Los Gatos	San Mateo
Bishop	Loyalton	Santa Ana
Black Diamond	Madera	Santa Barbara
Burlingame	Martinez	Santa Clara
Calistoga	Merced	Santa Cruz
Chico	Mill Valley	Santa Maria
Coalinga	Modesto	Santa Monica
Colton	Monterey	Santa Paula
Colusa	Mountain View	Santa Rosa
Compton	Napa	Sebastopol
Concord	National City	Selma
Coronado	Newman	Sierra Madre
Corona	Newport Beach	Sisson
Covina	Oakland	Sonoma
Crescent City	Oceanside	Sonora
East San Jose	Orange	South Pasadena
Elsinore	Oroville	South San Francisco
Emeryville	Oxnard	St. Helena
Escondido	Pacific Grove	Stockton
Etna	Palo Alto	Suisun City
Eureka	Pasadena	Susanville
Fairfield	Petaluma	Tehachapi
Ferndale	Piedmont	Tracy
Fort Jones	Pinole	Tulare
Fowler	Placerville	Vacaville
Fresno	Pleasanton	Vallejo
Gilroy	Point Arena	Visalia
Glendale	Pomona	Watsonville
Hanford	Red Bluff	Whittier
Hayward	Redding	Willits
Hercules	Redlands	Winters
Hermosa Beach	Redondo Beach	Woodland
Hillsborough	Redwood City	Yreka
Huntington Park	Richmond	

Every city belonging to the League of California Municipalities is entitled to a free copy of this magazine every month for each of its officials; if not received kindly notify the Secretary. See that your City is in the above list.



# PACIFIC MUNICIPALITIES

▲ Journal for Progressive Cities

VOL. XXIV

JUNE 30, 1911

No. 5

PROCEEDINGS  
THIRTEENTH ANNUAL CONVENTION  
OF THE  
LEAGUE OF CALIFORNIA MUNICIPALITIES  
HELD AT  
SAN DIEGO, CALIFORNIA, November 15th to 19th, 1910

GROUND SQUIRREL EXTERMINATION AS A  
SANITARY MEASURE

BY DR. RUPERT BLUE

It may seem a far cry, gentlemen, from the last two papers to my subject. But if you will follow me for a few minutes, I will try and show you the connection between them.

I have just recently returned from an eight months' investigation of public health matters in Europe, South America and Panama.

While in South America I attended the International Congress of Medicine and Hygiene at Buenos Aires as a representative of the United States. Problems relating to the public health of various countries were discussed at this Congress. Although I did not introduce the subject of plague among the ground squirrels of California, I consider it far more important, and of a more serious import, both to the United States and the world at large, than any of those which were presented.

Plague infection exists today in Argentina, Chile and Peru, but so far as I was able to ascertain, the problem of its eradication is not so difficult as it is in this country. The reason for this can be explained in a few words. The animals that are responsible for its dissemination are found in the cities only, while in California the rural districts, as well as the towns, are overrun with rodents of one kind or another.

Because of this condition it is possible for plague infection to pass from city to country and from country to city in an endless chain. This has actually occurred in this State. In 1907, a year after the great fire, the disease appeared for the second time in San Francisco. The investigation which followed

showed that the ground squirrels of Contra Costa County were infected, and that, in all probability, the city had received its infection from the country.

This is not at all improbable in view of the fact that the rodent range is practically continuous in the State. What actually occurred in this case was an exchange of fleas between the urban rat and its rural neighbor—the ground squirrel. Moreover, it is a matter of common knowledge that these two animals always live in peace and harmony in the same burrow. At certain seasons, when food is scarce, the urban rodent migrates to the suburbs, and there comes in contact with the squirrel, thus completing the chain of communication between city and country.

Plague has been demonstrated in ground squirrels from Contra Costa, Alameda, Santa Clara, San Benito, San Joaquin, Merced, Stanislaus, Santa Cruz, San Luis Obispo, Monterey and Los Angeles Counties. Human plague has occurred in Contra Costa, Alameda, Santa Clara, San Benito and Los Angeles Counties. In a number of these an intimate association with ground squirrels was shown. Contact with the sick animal, however, does not seem necessary, for one of the cases, a young lady, who lives near San Jose, contracted the disease by habitually riding over a squirrel-infested hayfield. Infected squirrels had been obtained from several ranches in the vicinity.

Human cases from plague infected squirrels will probably never reach epidemic proportions, because of the limited opportunity for contact between man and squirrel fleas. However, these cases will occur from time to time, in the infected counties, and on this account physicians should be prepared to find and promptly report them.

From a review of the situation it becomes evident that there must be an absolute eradication of the ground squirrel. It is necessary to eliminate what threatens to be an endemic focus of bubonic plague in America. Squirrel extermination is of utmost importance because of the danger of reinfecting the rat population of our cities and again causing human plague in epidemic form. Aside from the fact that extermination is a public health measure, the farmer and orchardist should know that it is of the greatest benefit to him in an economic sense.

The ground squirrel, according to Merriam of the United States Biological Survey, causes a loss to agriculturists of ten millions of dollars annually. In view of their wide distribution and great numbers on our Pacific Coast, this estimate does not seem to be excessive. The danger to human life, however, far exceeds in importance the damage to crops, and confers upon the squirrel an evil reputation not heretofore known or suspected.

These considerations naturally lead one to inquire what measures should be adopted to stamp out the epizootic among the ground squirrels? There is but one answer. Nothing less than a constant, well directed warfare, based upon scientific methods, and having the co-operation of the farmer, orchardist and ranchman, will accomplish the result.

It should be stated, in this connection, that the Federal Government has made a liberal appropriation for this work and will detail Medical officers, and other employees, to cooperate with state and local officials. Efficient work has already been done in a number of localities in the state. Protection has been afforded San Francisco and the trans-bay cities by the creation and

maintenance of rodent-free zones around them.

#### THE AREA OF INFECTION

The Public Health Service of the United States, working in cooperation with the State authorities, has investigated in the last eighteen months, the conditions as regards squirrel plague in twenty-eight counties. As a result of this work the boundaries of the infected area have been defined within the State. It has been found that the infection does not as yet extend north of Suisun Bay nor east of the San Joaquin River. The Southern limit has been located somewhere in San Luis Obispo County.

During the investigation more than 180,000 squirrels were collected and examined bacteriologically in our San Francisco laboratory. Of this number 394 showed the gross and microscopic lesions of plague. As above stated infection was found in ten counties. Some idea of the magnitude of the problem can be obtained by examining the map of the State of California. It will be found that these ten counties comprise an area of 20,000 square miles, a great portion of which is mountainous and difficult of access.

#### REMEDIED MEASURES

For a number of years the focus of sanitary interest within the United States has continued to center about the California problem. It is of national importance, and for this reason several State administrations have investigated it with a view to providing adequate means for its control.

The last Legislature, in March, 1909, very wisely placed upon the Statute books a law called the "Act for the Extermination of Rodents." This law requires all citizens in any way concerned, "At once to proceed and to continue in good faith to exterminate and destroy

rodents by appropriate means." Boards of Supervisors and City Councils, under the terms of the Act, are authorized to provide funds and undertake eradica-tive measures. Funds for this purpose may be raised by a "special sanitary tax", of one-half mill, on all property outside of incorporated districts.

A state-wide movement for the extermination of this serious pest is planned. To insure success there must be a simultaneous enforcement of the law by all landowners aided by the constituted authorities.

An experimental plan has been drawn up and will be placed in operation at an early date. For administrative purposes, as well as for the sake of economy, it will be necessary to organize each county separately taking the Supervisor's district as the natural working division or unit. As the county is the source of authority, all work must be performed under the aegis of the Board of Supervisors. These Boards will be asked to appropriate a definite amount annually as it will be necessary to know the exact sum available for expenses. It is proposed to use County funds in the payment of Inspector's salaries only. County Inspectors will be appointed for a definite period each year by the Supervisors, but their duties will be defined by the health authorities, State and Federal, in conference with the County Boards.

In further elaboration, it should be stated that the plan contemplates the establishment of a Camp of Instruction to be located in the squirrel infested region. In order that the work may be made practical, instruction will be given in the field to employees and owners of property in the vicinity. This camp, while designed primarily as a means for the training of Federal employees in the destruction methods, may be made



available to landowners for a similar course. The cost of maintenance will be charged against the Federal fund.

In addition, expert Federal Inspectors will be available for county service whenever required. To them will be assigned the duty of organizing local campaigns, of instructing the public as to the best methods to be employed, and of cooperating with the county officials.

It is to be hoped that all physicians, public school teachers, municipal and county officials, and the public generally will cooperate in every way possible with the health authorities in the fight against this enemy that lurks in many communities of the state.

I have here a map of California which shows the amount of work that has been done up to date in the squirrel campaign, the locality where work has been done being shown in yellow, while the infected area is shown in red. You will find from an examination of this map that the infection does not go north of Carquinez nor east of the San Joaquin river nor south of the upper region of San Luis Obispo County. Just how far it extends east, and just how far it extends west of this north line, we have not yet ascertained. But I have some seventy-five to one hundred men collecting squirrels throughout this region now, in an endeavor to find out just the extent of the infected zone. As yet, there has been no infection found in San Mateo County, and we have collected quite a number of squirrels from that region.

A DELEGATE. Besides rats and squirrels, do you include cottontail rabbits?

DR. BLUE. No, only rodents.

THE PRESIDENT. While we have the lantern, we will ask Mr. Van

Ornum to run through the street slides as rapidly as possible.

## OIL MACADAM PAVEMENT

MR. VAN ORNUM. An oil macadam pavement, as you all probably know, consists of crushed rock, the largest sizes being in the foundation, and decreasing in size as we go towards the surface, and in the surfacing layers, either one or more layers, is spread the heavy asphaltic oil, either in its crude state or partially refined. The principal object of the oil macadam pavement is to prevent the raveling due to the heavy moving automobiles. The advent of the automobile has rapidly raveled the old macadam pavement, which was not bound with any material like asphalt or coal tar products. The fast moving wheels of the automobile shears the pavement and takes up the dust. Then the larger particles of the macadam are in a condition where they are easily removed from the streets. I recall reading in a magazine two years ago the fact that a macadam pavement in Switzerland, I believe it was, which had been constructed for a great many years and been thoroughly satisfactory until the railroad had an accident there and automobiles were put on the road, and in about a week that road was torn to pieces. This shows what the automobile will do if the pavement is not thoroughly bound with materials like an oiled asphalt or coal tar products.

We have an excellent material here in California in our oils, either in the crude state where it is heavy enough, or in its partially refined state. There are several cities in California which have constructed many miles of oil macadam pavement.

Q. How many inches of rough rock do you put down to form the roadbed,

well crowned, before you supply the oil?

A. That depends. There are two processes which are used. In some cities the oil is only applied practically after the street is completed, a half gallon or three-quarters of a gallon, or a gallon applied, and screenings put on there, which form practically a carpet over the macadam pavement. Another construction is, to spread the oil when the pavement is brought up, say within an inch and a half of the surface, and then screenings are put on that, and then more rock and more oil and more screenings.

Q. Have you engineers agreed upon a formula to recommend for macadam pavement?

A. No, we have not. We are investigating the subject more thoroughly. A committee appointed by the engineering section has decided that they are not yet in a condition to recommend standard specifications which would be adaptable to all parts of the big State of California. The oil macadam pavement is thoroughly satisfactory in regard to sanitation, and the streets which we have in Pasadena, for instance, are thoroughly cleaned, the same as a sheet asphalt pavement is. We have men on the street every day

cleaning the pavement, and at night, when needed, we run the street sweeper over it, so that it is thoroughly sanitary, it is dustless, not as dusty as a sheet asphalt pavement, or a hard pavement, and it is not muddy in the wintertime, and to all appearances, it is like a sheet asphalt pavement, except as to its not being as dusty, as I have stated. It is very satisfactory, under certain conditions.

It does not supercede the asphalt pavement or the hard pavement, but it has its place in street paving, on residence streets, on side streets, where there is no heavy traffic, and the paving is good. I want the members of the League to take this into consideration, that this pavement does not take the place of brick or asphalt or other hard pavement, but can be used in some parts of every city.

Q. How long does the oil carpet last where you put it on entirely?

A. It lasts three or four years. In Sacramento, I think they build the road up to within  $2\frac{1}{2}$  inches of the surface before they apply the oil, and then they apply the oil and put on an inch of rock,  $\frac{3}{4}$  inch rock, then they roll that down, and then half a gallon of oil on that, with  $\frac{1}{2}$  inch of screenings. (Slides exhibited.)

## REGULATING PUBLIC UTILITIES

BY H. A. MASON

A commentary on Senate Constitutional Amendment No. 47, which is a proposition to amend Section 23 of Article XII of the Constitution and thereby confer power upon the Railroad Commission to supervise and regulate other public utilities besides railroads.

The purpose of the amendment is to confer additional powers upon the State Railroad Commission.

powers to be conferred may be summarized as follows:

To supervise and regulate public utilities in the State of California and to fix

A segregation of these additional

the rates to be charged for commodities furnished or services rendered, as shall be conferred upon it by the legislature.

"Public Utilities" are defined to be "every private corporation, and every individual or association of individuals owning, operating, managing or controlling any

1. Commercial Railroads,
2. Interurban Railroads,
3. Street Railroads,
4. Canals,
5. Pipe lines,
6. Telephone or telegraph lines,
7. Light, heat, water or power plants,
8. Furnishing storage or wharfage,
9. Any other class of private corporations, individuals or associations hereafter declared by the legislature to be public utilities."

The phraseology of the amendment which declares a corporation or individual to be a public utility may be properly criticised. Ordinarily we have not conceived the corporation or individual to be a public utility, but instead of personifying it, it would have been more proper to define the business of furnishing the services and commodities described as being and constituting public utilities. Such is the evident intention and undoubtedly will be so construed.

It will be noted that the amendment itself does not confer these additional powers upon the Railroad Commission, but merely permits the legislature to vest such control in the commission "as may be provided" by it, and to exercise such power and jurisdiction and fix rates "as shall be conferred upon it by the legislature."

The amendment is not self-executing and will require legislation to make its provisions operative. Therefore any benefits to come from the adoption of this amendment will depend upon attitude of future legislatures in this con-

nection, and the efficacy of the laws that may be hereafter enacted.

We may be justified, however, in assuming that the next legislature to meet after the adoption of the amendment, will exercise its "plenary" power by conferring upon the Railroad Commission complete jurisdiction to control all public utilities and fix the rates to be charged for commodities or services which they render to the public.

The powers that may be exercised under this amendment may be divided into two classes.

1. Powers not at present vested in any public body.
2. Powers at present exercised by counties and municipalities which may be surrendered.

Under the first sub-division may be enumerated—

- a. Power to control public utilities by regulating their stock and bond issues, accounting systems, requiring publicity, restricting acquisition and transfer of franchises, etc.
- b. Fixing rates of what may be termed "interurban services" such as long distance telephones, and telegraph rates, railroad fares between two municipalities or between points in two counties.

c. Fixing rates outside of municipalities for all services except water and wharfage. County supervisors in the several counties I believe, have no power to fix rates for anything except water and wharfage, and tolls on toll roads, the last particularly obsolete.

To my mind the legislature already has the right to confer on a state commission the foregoing enumerated powers, and bills were presented to the legislature with the view of creating a separate Public Utilities Commission. These measures also provided that the commission could act as an adviser to



the counties and municipalities in the matter of rate fixing by the local bodies. No amendment to the constitution was deemed necessary to accomplish this purpose.

Personally, I very much regret that the bills were not enacted as laws. I believe that a separate commission would have been in a position to deal effectively with these questions, a commission whose major purposes was to control the capitalization and methods of transacting the business of public utilities. I believe that this is much more important than the fixing of rates.

The main objections to these bills were that a new commission was to be created; that the state had too many already; that the expenses would not be as much if the duties should be disposed on a commission already existing. Hence it was proposed as a substitute to give the legislature power to provide for imposing these additional duties upon the railroad commission, and by another amendment enlarging the Railroad commission from three to five members.

I have questioned the wisdom of the abandonment of the original plan. In the end I doubt if any economy will result and I seriously fear that the Railroad Commission will find itself so overburdened with the new duties, in addition to the work already before it, that its ability to produce satisfactory results will be seriously limited. It is also to be noted that in case this amendment is adopted the legislature will be powerless to create a separate Public Utilities Commission. It would be the Railroad Commission or none. It is upon this point that I withhold my full approval of the amendment.

I apprehend that a few of our citizens outside of those interested in public service corporations are opposed to the creation of a public service commission,

or to vesting in a proper public body plenary powers to regulate the business of public service. The success of similar commissions in Wisconsin and New York may be cited as examples of wisdom in providing for some relief from the abuses that have grown up in connection with development of our public service corporations.

The regulations that may be applied with wholesome effort by a public body having proper powers to prescribe and enforce them may be stated as follows:

1. Requirements that will result in publicity of public service business.
2. Prescriptions as to systems of accounting and forms of reporting.
3. Control over stock and bond issues and supervision over expenditures.
4. Demands for improved public service to meet the necessities of the community.
5. Directing the use of safety appliances and sanitary methods in the conduct of this business.

One purpose of the proposed amendment is to confer powers on the Railroad Commission to impose such regulations upon the public service business.

To me it appears that the exercise of such powers are much more consequential than the power to fix rates of service.

I now come to the second purpose of the amendment viz: that which proposes to transfer to the Railroad Commission the power to fix the rates for public service that is now vested in the legislative bodies of the several municipalities.

It will be noticed that the amendment does not in its own terms operate to make such transfer of power. It only permits municipalities to surrender the power they now possess by an election held for that purpose within each mu-

nicipality, which power can be restored by a similar election.

I apprehend that there is no reasonable objection to this. It is a matter of local consequence. If any municipality has made a failure in its attempts to fix rates for any given service it might very properly let the State Commission try its hand at it.

There are many cases in which a state commission could do better than any local body.

Take the matter of telephone rates for example. Only two cities in the state have made any attempt to regulate telephone rates. The situation is complicated by reason of interurban service and the fact that one company serves a large number of municipalities. It is difficult for any body of local creation to properly apportion the capital investment to its particular locality and rates that would be just to all parties are difficult, not to say impossible, to establish.

The same difficulty appears when the same water company or same electric company serves a number of separate municipalities.

The situation is one that seems to require adjustment by some body that can take a view of the whole situation and arrive at a conclusion that approximates the scientific.

Many reasons might be given why municipalities in certain cases might surrender their rate fixing powers without self-injury and with every prospect

for resulting good. On the other hand there are individual cases where the municipality should not surrender such powers. This line of argument is one which should be addressed to the municipalities at the proper time—the time when the question of surrendering the powers is before them for decision.

The fact that it is a debatable question is the one reason for favoring this provision in the amendment. I, for one, see no harm in it. On the other hand it may be productive of good results.

The local regulation of rates of public service has been generally ineffectual excepting in one respect.

We note that the advanced cost of living does not apply to public service rates. Water, gas, electricity, transportation, communication, are no dearer than ten or fifteen years ago. In many cases much less.

The power that local bodies have over rates and the refusal to permit any increase, has no doubt been a potent factor in maintaining the status quo.

As a whole, I believe the amendment to be worthy of adoption. I would have preferred that a wholly new commission had been provided to carry out its provisions. But, should it hereafter develop that the Railroad Commission cannot efficiently handle the amount of business that is placed upon it, we can propose another amendment which will give the necessary relief.



## SUMMING UP RESULTS OF THE NEW TAX LAW

BY HON. A. B. NVE, STATE CONTROLLER

Half a year has elapsed since the adoption of the revenue amendment to the constitution, and the ensuing act of the Legislature has been on the statute books for more than two months. The

work of the Board of Equalization in making the first State assessment roll is nearing completion, and the county assessors also have their rolls well advanced. Several cities, including Stock-

ton and Eureka, have completed their assessment and equalization, and so far as known at this writing without any very serious trouble in applying the new legislation.

All of this may be taken as indicating that the complexities of the new system, which it was feared would render its administration difficult almost to the verge of impossibility, have proved to be not so serious after all. It is not well to exult too soon, and possibly the real troubles will manifest themselves after the first stage of administration has been passed and that of litigation begins. It remains to be seen. But so far the new tax law has worked with less friction than was looked for.

Difficulties foreseen are half conquered in advance. To illustrate, the segregation of operative from non-operative property of railroads, light and power, express and other companies, which was expected to give rise to so many conflicts of interest between the counties and the State, has been accomplished with surprisingly little difficulty. It is necessary to qualify this a little because there are still some questions not settled, but the number is becoming less every day, and the State Board has been called on to make few decisions, because the county assessors and the corporations have adjusted their difficulties between themselves mostly without resort to State authority. A conciliatory attitude on the part of both the corporations and the counties has contributed to this result, and agreement was not difficult when each side asked only what was just. The attitude taken by the State Board has also exercised an influence, for that body wisely decided to have only those troubles which were absolutely unavoidable, and to that end it early gave out the ultimatum to county assessors and corporations that they must fight their

own battles. They have fought them, generally to a finish, and, with few exceptions, without any formal intervention by the State. On one occasion it was found necessary to send a committee of the State Board to Los Angeles to bring assessors and corporations together, but it was a mission of diplomacy and not of force.

The State was able to take this position because in the great majority of instances no question of State revenue has been involved. The four, or three, or two per cent. of gross receipts from the operation of the business was assured to the State in any event, and it assumed that it could trust the county assessor to defend the interests of his county. The State's representatives did, however, when the issue was brought up in the case of the Southern Pacific Company, decide that warehouse and other rental receipts of the railroad companies were not taxable, thereby giving both the counties and the cities the opportunity to assess the property which produces these receipts.

As for the city assessors, less is known to the present writer in regard to their progress where they have been at work independently, but it is presumed that in most cases they have consulted with the county officers and have adopted their methods, if not all of their conclusions. It has been reported several times that certain city and town assessors have started out to assess all corporation property, whether withdrawn or not, but such reports have not been verified. Naturally the attempt to do this would result only in profitless expense for litigation.

From a revenue-producing point of view it can now be said that the new tax plan has been successful so far as concerns the State itself. The estimates which the Tax Commission made of the



amounts of revenue which the various corporation taxes would produce have been justified; in fact, the railroads, banks, express, telegraph and telephone, and insurance companies have exceeded the estimates which were furnished to the Legislature and which were then generally thought to be inflated ones. Only the car companies and the light and power companies have yielded less revenue than was anticipated, and in the latter instance the shortage is only about ten per cent. On general franchises the aggregate tax will equal or exceed the estimate made.

Under these circumstances the State will apparently be able to get along without a "come-back," or deficiency tax, which will be good news to taxpayers at large. Their burdens are going to be heavy enough in all conscience this year, and it is fortunate that to them will not be added a general property tax for State purposes. Whether the same condition will prevail next year and in the years following is something which can not be predicted at this time. For State purposes it will be necessary to raise next year a quarter of a million more than this year; increased corporation receipts should more than make up that difference, but there are some uncertainties, particularly with relation to the franchise tax. It is unfortunate that the State has two taxes so nearly alike as the corporation license tax and the franchise tax, and if we have an extra session of the Legislature, as is now anticipated, there may be legislation which will alter conditions sufficiently to make the ensuing year's revenues rather uncertain.

Until the county assessors finish their work and report no very definite statements can be made concerning the way in which the counties will fare this year; but it is already apparent that there will

not be the general and heavy increase in assessments which it was predicted would occur as soon as the counties were relieved of the burden of the State tax. With few exceptions the county assessors seem to have preferred waiting until there could be a positive assurance that the State tax was indeed gone before considering a wholesale raising of the roll. Next year may see the full operation of the tendency which was restrained this season.

Judging by what reports have come in, the cities have elevated assessments more than the counties have. There was greater necessity for it. While county tax rates are not limited by law, almost every municipality has such a limit, and the limit had usually been reached before the constitutional amendment withdrew a considerable part of the assessable property. To raise the assessment was therefore the only thing which could be done. It has always been admitted that its effect on the finances of municipalities and of certain districts was the seamy side of the new revenue plan, and only by balancing their gains as taxpayers of State and county against their losses as municipal taxpayers can the residents of cities find consolation. In many rural counties the gains will largely outweigh the losses.

At any rate these corporations which have usually been accused of evading the payment of their due share of taxes have been made to pay more. The railroads and street railroads will contribute not very far from five million dollars to the expenses of government, and the power companies, telegraph and telephone companies, express companies and banks have largely increased their contributions also. This will generally be conceded to be a substantial gain which must be credited to the new sys-

tem, which, however, really began to yield good results in the case of the railroads before it was formally adopted, because beginning as long ago as 1907 the State Board of Equalization began to ap-

ply the four-per-cent rate of tax in the assessment of railroad property, thereby making a heavy increase on the assessments previously levied.



## THE AUDIT OF MUNICIPAL ACCOUNTS

BY WILLIAM DOLGE, C. P. A.

The election in cities of the fifth class are over. The new Board of Trustees and the new officers are beginning to be a little more familiar with their duties and they find many things strange, conducted in a way differing materially from preconceived notions. They are beginning to appreciate that their predecessors in office contended with problems that seemed very easy of solution from the outside, but are now found to contain many features that had not been touched upon. Precedents of various kinds and legal provisions are found to limit the activity of the officials, and after the first enthusiasm has worn off, most of the newly elected servants of the people are quite content to let matters go on in the same rut as their predecessors.

But there are exceptions to this rule. There are officers that "want to know" and so one of the first steps of the new Board of Trustees will be to call for an examination of the books and accounts. Without impugning the integrity of anyone it may be stated that most of these examinations are without practical result. From motives of false economy it is usual to engage the services of an experienced bookkeeper to "check" the accounts. This bookkeeper is nearly always a local man and whether or not his engagement is due to political preference, the work he does,—so far as he

does it—is accurate enough but of no practical value. In short this "checking" of accounts rarely amounts to anything more than the verification of the arithmetical accuracy of the clerk's demand and Warrant Register, of the Treasurer's books, and the reconciliation of the books of the clerk with those of the treasurer. This is not an audit. As well say that the reconciliation of the balance as shown upon your check book, with the balance the bank as per the bank statement or pass book, is an audit of your own accounts. Such checking is nothing but a confirmation of the fact that the books of the treasurer are in arithmetical agreement with those of the clerk, and it cannot disclose any error except those of a purely clerical nature, or the absolute misappropriation of funds by the theft of moneys by the treasurer or from the treasurer's office.

It is not advisable to detail here all of the many different kinds of misappropriations that this kind of "checking" fails to detect, for the reason that it is against the public policy to indicate how fraud may be committed. There are to be pointed out, however, certain other features that such a "checking" does not include and which are a part of a proper examination of the affairs of the municipality. This includes an examination of the ordinances and resolutions

for the purpose of assuring the legality of the authorizations for payments. The examination of particular license ordinances for the purpose of determining whether the actual amount of licenses collected is in the proper relation to the licenses that *could* be collected. It includes a complete verification of the accounts of the marshal, license collector and of the tax collector, and it should include at least a superficial examination of the assessment roll. Finally a list of the unpaid demands on file should be prepared and inquiry made with reference to this. All of the above are purely matters of a technical audit, upon the conclusion of which the sum and substance of the auditor's report would be that the accounts are in order or that they are not in order, stating in the latter case the defects that may exist. Such an audit has a distinct value because by pointing out the errors that have been made their recurrence can be prevented. But unless there are also included in the audit report an analyzed statement of the receipts and disbursements of the municipality, showing clearly the sources of the receipts and the purpose for which the disbursements were made, such an audit report fails in its most important function.

From this it will be seen that no bookkeeper, however expert a mathematician he may be, however thoroughly conversant with the mysteries of debt and credit, however rapid in his additions and in his other computations can be equipped with the knowledge essen-

tial for making a proper Audit Report. He is not familiar with the statutes governing municipalities, and for the nominal fee he receives he cannot so familiarize himself. He has no time to read the ordinances and cannot be sufficiently familiar with municipal practice to determine whether or not a resolution authorizing the payment of money is properly passed. In the writer's experience it has happened upon numerous occasions that the total amount of revenues uncollected, that should have been collected, and of which there was no records in either the clerk's books or in those of other officials exceeded the fee for the examination by from 300 to 600 per cent. In other words as the result of a thorough audit the trustees were put in possession of information which enabled them to collect license fees, rentals, overpayments, erroneous payments, and so forth, to an amount many times greater than the fee for the making of the examination. This will not hold true in all cases perhaps, but thus far there has been no exception to the rule within the writer's knowledge. It is not to be assumed that the examination of the accounts by the bookkeeper is absolutely without value. Not so. It is merely pointed out that reconciliation of the accounts of the treasurer with those of the clerk is but the first step in the proper examination of municipal accounts and is conclusive only as to the arithmetical accuracy of the clerk's books and those of the treasurer if the work has been properly done.

#### TRADE NOTES

The Thomas B. Jeffrey Company have just sold two runabouts to Sacramento, one for the fire chief and another for his assistant.

The Pacific Flush-Tank Company has been made the American and Canadian

representative of the Imhoff (Emscher) Purification Tanks, patented, for sewage disposal. Those desiring information regarding royalty charges, etc., should address The Pacific Flush-Tank Company, Chicago or New York.



## THE SIEBEN SYSTEM OF SANITATION FOR CLEANING AND DISINFECTING SEWERS

---

A simple mechanism for cleaning and disinfecting sanitary sewers was recently invented by Mr. Henry Sieben of Kansas City, Mo., which has been demonstrated beyond question to be a most remarkable success. The principle of the Sieben machine is a small turbine engine propelled by water power which is transmitted through a hose from a fire hydrant. The water from the hose passes through a cylinder and propels a sprocket, on the prongs of which are steel brushes that pulverize the deposit choking the sewer and cleans its sides. Behind the sprocket are hook-shaped blades which revolve rapidly and cut off roots or other vegetation. In so doing they also stir up the dirt and sediment in the sewer to a thin grout, which is carried back and out by the waste water from the turbine. The machine is drawn slowly through the sewer by means of cables operated by a windlass. Four men are necessary to operate this machine, two on the windlass running the machine through the sewer and two feeding in the hose at the manhole.

The machine is so constructed that it will meet all the requirements necessary to clean out obstructions regardless of the nature of the matter choking the sewer. When it is connected with the hose and a water pressure of 60 pounds behind it, three horse power is generated by the turbine. This makes the cutter blades and brushes revolve with such rapidity and force that weeds and roots are cut up and all matter choking the sewer is dislodged, ground up, and carried out with the flow of water. A cartridge containing a disinfectant may be inserted in the machine, and this

permits a certain amount of the chemical to escape during the operation, as a result of which the sewer is not only practically cleaned and scrubbed, but also disinfected.

In the event that the sewer is entirely clogged, making it impossible to pass a cable through the pipe, a special forcing jack with a number of coupling rods is provided, making it possible to force the machine through the sewer, first allowing it to run for a time in order to soften the obstruction.

The Board of Public Works of Kansas City, Mo., recently ordered that the Sieben system of cleaning sewers be purchased for the use of that city. The machine was taken out to demonstrate what it could accomplish. A sewer which had formerly cost the city \$800 and a month's time to clean was thoroughly cleaned and disinfected by the Sieben machine in eight hours and forty minutes, at a cost of \$11. Referring to another and later test of the machine in that city, Mr. Theodore Naish, engineer in charge of the work, reported as follows:

"The Sieben machine was to clean the water from manhole No. 1 to No. 2. The average depth of sediment in this sewer was about twelve inches. At 12:30 p. m. the Sieben crew, consisting of four laborers, one foreman and one team began the work of stringing hose to the nearest fire plug, 1250 feet distant, and getting rods through the stretch of sewer between No. 1 and No. 2 preparatory to running the machine through. All preparatory work was done, water turned on and the machine started from manhole No. 2 at 3 p. m. A few

minutes after the machine was started a length of hose burst, which caused a delay of 12 minutes while a new length was being put in. The machine was taken out at manhole No. 1 at 3:42, having traversed 371 feet of pipe in 42 minutes, or deducting the 12 minutes delay for restoring hose, the actual time of cleaning the sewer was 30 minutes. The hose was taken up and rolled and everything cleaned and put away by 5:30 p. m. That this sewer was actually cleaned was shown by running a Shannon bucket through the sewer after the Sieben machine had gone through. In the whole length of the sewer only about one-third of a cubic foot of dirt was gathered in the bucket. The cost of the work was as follows:

Foreman 5 hours at 37½ cents	\$1.85
Team, 5 hours and 50 cents	1.50
Labor, 20 hours at 25 cents	5.00

Total labor cost \$9.35

Length of sewer cleaned 371 feet.

Cost per foot of sewer by Sieben machine, 2.52 cents."

Since purchasing the machine over 7899 feet of sewers have been cleaned in Kansas City, at a total cost of \$246.62 or an average of \$3.15 cents per foot, where formerly it cost from 40 to 80 cents per foot. Mr. Theo. S. Jones, Superintendent of Repairs, Board of Public Works, says, "I consider the work done by the Sieben system a great saving to the city as well as accomplishing the work intended, namely, clean and sanitary sewers." In reporting another case Mr. Jones says:

"The sewer was completely stopped up within one inch of the top with marble dust, core sand, slime and fecal matter. Same was stopped up to such an extent that it was impossible to force a three-fourths "iron rod through same over 26 feet with a Barrett forcing pipe

jack, same having the forcing power of ten tons. This applies to 300 feet of the sewage. In this 300 feet the Sieben machine was inserted into the sewer at the manhole at the lower ends, the rods were connected to the machine, as the machine ground up the matter in the sewer into a grout and allowed the matter with the water to pass by same, the machine was forced through the sewer, cleaning, sweeping and disinfecting same in less than one day's actual working time.

In my opinion, had it been possible to force the pipe through the sewer so as to attach the cable to the machine, the sewer could have been cleaned in less than half a day. The other hundred feet through which the cable was passed, was cleaned in forty minutes, actual time. In conclusion, wish to say, that this stretch of sewer has cost the city hundreds of dollars to dig up and clean, in order to pass through the matter in this sewer, and this demonstration has convinced me, without any possible doubt, that the Sieben System is a practical system, and if used by the city will mean the saving of thousands of dollars to the taxpayers, and will solve the question of unhealthy and clogged up sewers. I wish to say, that this test was made by employees of the street department under my personal supervision. I heartily recommend that the city adopt the Sieben System and purchase one machine for each district." From the report of Theo. S. Jones, Superintendent of Repairs of the Board of Public Works, Kansas City, Mo.

This investigation and test in Kansas City was brought about by reason of the bad condition prevalent in the eastern part of the town. Complaints had been received from numerous residents of the offensive odors continually arising from the manholes, and in one neighborhood

thirty-two cases of typhoid fever were reported from one school.

Commenting on the showing made by this machine the "Kansas City Municipal Facts," official organ of the municipality, says that the Sieben System is a great boon, and solves a problem of great importance to every city that regards municipal sanitation and cleanliness as of paramount importance. In "Municipal Engineering" for June, 1911, an account is published of some work done by this machine in Cleveland, Ohio. The article is accompanied by a photo-engraving showing an obstruction consisting of a compact mass of roots which had become so interlaced as to cause a great deal of trouble. This obstruction was entirely removed.

In California, Sacramento was the first city to try this new mechanism for cleaning sewers. The results verified all the claims made for it in the east. The officials at Sacramento selected their worst sewer as a test for the machine. This sewer was in such a bad condition that it was a foregone conclusion it would have to be taken up and relaid. The result of the test is embodied in the report of the foreman of the Sanitation and Drainage Department, and reads as follows:

"Gentlemen: At the request of the Sewer Committee of the Board of Trustees and under the supervision of the Street Superintendent and City Engineer

of this city, I used the Sieben Sanitary Sewer Cleansing machine on the 14 inch sewer in Seventh street between E, F, and G streets. This sewer was filled with ten inches of solids and had a flow of ten inches of asphaltum and base oil sewage. It has always been the worst sewer in our city and it was considered only a matter of time when it would have to be taken up and relaid for the entire 900 feet. We went through it for 490 feet with a pressure of fifty pounds of water and for the balance of the 900 feet we used only thirty pounds of water pressure. We cut cotton waste, rubber gaskets and roots and sand gravel, and I have to report that the sewer is now as clean as it was the day it was laid, some ten years ago.

A. S. MURPHY

Foreman Sanitation and Drainage Dept."

Municipalities having trouble with their sewers would do well to investigate this new cleaner and disinfector. One of the machines will be on exhibition at the next convention and exposition of the League at Santa Barbara, and an effort will be made to have a practical demonstration of its work at that time.

NOTE. Further information regarding the Sieben Sanitary Sewer Cleaning Machine, may be obtained from the office of Pacific Municipalities.

### SHY OF GARBAGE

There are about 5000 cities in the United States that are in more or less trouble and expense because of the amount of garbage they produce; there is one city, however, that is put to a great deal of trouble and expense because it does not produce garbage enough. This is Dayton, Ohio, which some time ago entered into a foolish

agreement with a reduction company that if the latter would set up a plant the city would provide a certain amount of garbage. The amount was a gross over-estimate, and in course of time the company brought suit and actually got a judgment of \$79,000. Later the company began another suit, this time for \$89,000 more.



### TYPHOID DECREASES

---

A report just issued by the Cincinnati waterworks department makes a remarkable showing in the falling off of deaths from typhoid fever in that city, since the new waterworks system was placed in operation. The Cincinnati waterworks completed in 1907, cost eleven million dollars. The water supply is taken from the Ohio river, the intake, settling basins, and filtration plant being located about seven miles above the city. The filtration plant has been declared to be one of the best in the world. The old waterworks had no filtration plant.

In 1910 there were only twenty-one deaths in the city from typhoid fever, compared with 239 in 1906, the last year of the operation of the old waterworks. The total of deaths for the three years ending with 1910, was 133, compared with 664, the total of the last three years of the operation of the old system. The number of lives thus saved by pure water was 531.

The report shows that since the establishment of the new waterworks the typhoid fever death rate in Cincinnati has dropped to 5.7 per 100,000 people, the lowest among the important cities of the country.

Also there has been a falling off of deaths from other intestinal diseases of from 563 in the years of 1904, 1905 and 1906 compared with 246 for the last three years, a saving of 317 lives.

The grand total of lives saved by pure water in the past three years is 848.

Not only has the new waterworks effected a tremendous saving in human life, but it is costing the city about half the amount which was necessary to operate the old system. The report shows that the cost of pumping water in 1910 was only \$14.36 per million gal-

lons, compared with \$32.05 per million gallons in 1906, from the old waterworks. In 1906 the cost of pumping 15.2 billion gallons of water was \$487,201, while in 1910 nearly 17,000,000,000 gallons were pumped for \$243,545.

It has been demonstrated that the entire cost of the waterworks can be paid out of the revenues of the water department.—From the City Hall.



### ONE REALLY MODERN AMERICAN CITY

We have often prophesied that American cities will sooner or later copy the best features of municipal administration in German cities.

Lockport, N. Y., is probably the first to copy the German system completely. Lockport has just advertised for the services of a high-class, well-paid civic expert, who will perform the duties that usually belong to a Mayor's office. The successful applicant must have a record in civic administration.

As a preliminary to this radical move, Lockport adopted the commission form of government. It appointed five prominent citizens to take complete charge of municipal administration without salary. They constitute a civic board of directors, and will hire a business manager.

As one commentator remarks, this expert will have the entire city administration turned over to him with this injunction: "There's your work. Take it, run the city, hire your help, keep things clean, keep things healthy, be progressive and we will watch and check results."

Lockport evidently believes in the recall principle, also, for the business manager will not be hired for any specified contract period at present. The city is feeling its way, as it were.

Here, at last, we have commission government brought down to date. The commission form of government, with the German system of hiring civic experts added to it, ought to bring results.

Other American cities will keenly watch the outcome of Lockport's experiment.

## ON THE NEED OF RESEARCH IN THE MANUFACTURE OF ASPHALT FROM CAL. PETROLEUM

BY D. BASIL W. ALEXANDER, PACIFIC COAST CHEMIST OF THE BARBER ASPHALT PAVING CO.

The popular theory in the manufacture of asphalt from petroleum with an asphalt base is that the asphalt is held in solution by the distillates, and that when these are removed by distillation the asphalt is left in a solid state in much the same way that maple syrup is obtained by boiling of water. Perhaps this is partly true, but it certainly is not completely so; and the proof (if any is needed) is in the instability of the asphalt when made, as evidenced by the gradual hardening that goes on after the material is cooled, and this may extend over a period of several years, and is partly the reason of the failure of many pavements in the past.

It is only a few years ago that it was considered that all that was necessary was to heat the oil, irrespective of temperature, until the residue was hard and shiny, and could be chewed without too much exertion. There is no doubt that great improvements have been made during the past few years in the methods of distillation; but we are still very much up in the air about the quality and physical properties of the asphalt as at present made; though since it has been found possible to make the grade below 600° Fahr. the material has shown great steps towards improvement. One disadvantage we are under is that we cannot tell how much improvement has been made until after the lapse of several years; for it reaches over that period for asphalt to come to a point where the mass is in a state of equilibrium, or rest. To help to illustrate my point, but without going too deeply into scientific phraseology, I will state that carbon is known as a tetrad element, meaning that it will combine to form stable or saturated compounds with 4 monad elements, such as hydrogen, or chlorine, forming respectively marsh gas and carbon tetra-chloride. Thus the atom of carbon may be represented by a tetra-hedron, and marsh gas  $\text{CH}_4$  has all the corners combined with hydrogen; in the same way that carbon tetra chloride  $\text{CCl}_4$  has them all combined with chlorine. An unsaturated compound has one or more corners not combined with any elements, and is therefore in an unfinished state, and constantly striving after completion. Thus the molecules in an asphalt fresh from the high temperatures of the still may be likened to a mass of tetra-hedra, one quarter of the atoms of which are heavier in one apex, that is unstable, and are capable of movement; the others, or stable atoms, rest on their bases. It is evident that the mass will be in a state of unrest until all the downward pointing apices are fitted into the spaces left by the other stable tetra-hedra standing on their bases; at this time the bulk of the mass will have reached its point of equilibrium, and no further settlement will occur, and the mass will be denser; in asphalt this is indicated by the harder penetration.

The object of asphalt manufacture is to reach this point of stable equilibrium without lowering the quality, before the material leaves the still, and this is attempted in various ways. One method is by reducing the grading temperature by various means; which leaves the asphalt in its proper condition of plasticity, and is perhaps the best method. Another method is by oxidizing the material in the still; this presupposes the theory that the final rearrangement of molecules is due to oxidation, a non-proven supposition; this method destroys the essential plasticity of the material, making it "short", and that has to be restored by artificial means, when it is not certain that the final product will not suffer deterioration in ensuing years. As an indication of the problems we are up against I may state that an asphalt made from oil from the Lakeview horizon contains 30% more malthenes than an asphalt of the same penetration made from a Palmer well in the Santa Maria field.

## EDITORIAL

### THE INTERNATIONAL MUNICIPAL CONGRESS AND EXPOSITION AT CHICAGO

The government authorities at Washington have officially approved the International Municipal Congress and Exposition to be held at Chicago, September 18-30 next, and President Taft will address the Congress. By instruction of Secretary of State Knox, the United States consuls have asked the foreign cities to participate.

A good showing is expected on the part of the municipalities of California both as to exhibits and participation in the Congress. By request of the League officials, the California Development Board has agreed to send a competent speaker to Chicago who will deliver stereopticon lectures during the exposition showing our municipal achievements. There will be no charge for space for exhibits illustrating municipal development and city or town officials desiring to exhibit will kindly inform the secretary of the League at once. In this connection see circular letter sent out under date of June 29th.

### OUR NEXT CONVENTION AT SANTA BARBARA

The fourteenth annual convention of the League of California Municipalities will be held at Santa Barbara, October 23rd to 28th, 1911. There will be an exposition of machinery and supplies such as there was at San Diego, except this time it will be much larger. Nearly

all the supply houses who exhibited last year will be represented at Santa Barbara, together with many others.

### THE NEW TAX SYSTEM A SUCCESS

The fear that was aroused over the adoption of the new tax system provided by Constitutional Amendment No. 1, appears to be groundless. The State Board of Equalization has the preliminary returns of the corporation incomes for the year, and now announces that they will reach a larger figure than was ever raised by the old property tax.

The State's income, estimated from the actual returns of the corporations, are now figured at \$10,375,000 for the current year, which is \$2,250,000 in excess of the estimates, and \$3,000,000 more than was brought in by the 35 cent State tax on property.

The result completely vindicates the judgment and foresight of the proponents of the new system.

Last year all the railroads of California together paid taxes only to the amount of \$2,102,190. This year the Southern Pacific Company alone will pay on the earnings it has reported to the State Board of Equalization the sum of \$2,470,228.

Last year Wells-Fargo & Co. paid about \$16,000 taxes on its operative property throughout the State. This year it will pay above \$100,000.

The banks pay a much larger sum than before.

The cities and towns will be compelled to increase their tax rate however in order to make up the loss of license fees formerly collected from public service corporations, but this increase will not amount to the thirty-five cents here-



tofore collected by the State and consequently the aggregate tax on real and personal property will be lower.



### PORTLAND CONSIDERING COMMISSION PLAN

Portland, Oregon, has established a charter commission to consider a new form of government for that city. One of its members has been sent to Spokane to investigate the workings of the commission plan which many Portland people strongly favor.



### TRADE NOTES

The Reliance Automobile Company has sold an automobile pumping engine for fire fighting purposes to the town of

Willows. It is a triple combination affair, including water pump, chemical tank and hose carrying body, with a full equipment of accessories such as ladders, axes, extinguishers, etc., and will be delivered in about four months.

The California Corrugated Culvert Company have received a letter from Hon. E. E. Placek, Chairman of the Committee on Highways and Bridges of the State of Nebraska, regarding material for culverts. He says, "I have conducted a very thorough investigation as to the relative merits of the different materials now used for culvert purposes and I have made a recommendation that American Ingot Iron culverts are the most economical and durable culverts on the market. I am convinced that *Steel Culverts should not be used*, as they will last only about five years, while American Ingot Iron will last thirty to forty years."

**"VICTOR"**

**"RELIANCE"**

**"GUARDIAN"**

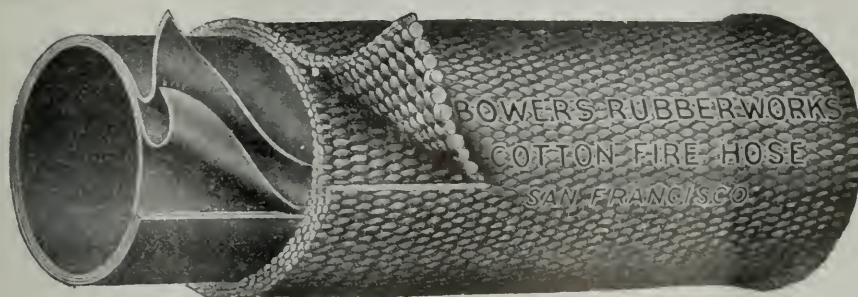

Made in California

**BOWERS RUBBER WORKS**

**SAN FRANCISCO, CAL.**

Phones { Pac. Kearny 168  
 { Home J 2941

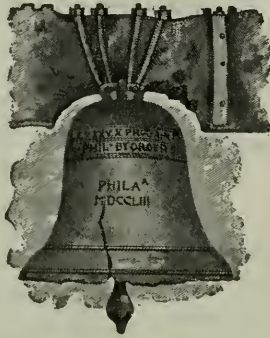

Cable Address  
 GARRATT  
 Codes, ABC--4th Edition  
 Western Union  
 Liebers

## Bell and Brass Foundry Machine and Hydraulic Works

ENGINEERS SUPPLIES

### W. T. GARRATT & CO.

277-299 Fremont Street

SAN FRANCISCO

## QUESTIONS AND ANSWERS

This department is for the use of city officials only. City Attorneys or others who may dissent from any opinion rendered or answers given, or who may be able to give additional information of value on the subject of any inquiry, are earnestly requested to write us at once in order that we may transmit such further information to the official making the inquiry.

Q. Is it necessary to the validity of proceedings under the "Improvement Act of 1911" or the "Vrooman Act" that the resolutions and notices be published in the official newspaper?

Ans. No; it is advisable however in order to prevent the question being raised.

Q. Can you send me an ordinance of recent enactment regulating to the storage of gasoline?

Ans. Yes, enclosed you will find copies of such ordinances recently passed in Sebastopol, San Francisco, Coalinga, and Los Angeles.

Q. I am desirous of obtaining copies of or-

dinances that have proven to be "good law" upon the following subjects;

Compelling telephone, telegraph and electric lighting companies to place wires underground;

Compelling railroad companies to place flagmen at crossings, and prohibiting the making up of trains at crossings. Can you accommodate me?

Ans. Enclosed you will find copies of the ordinances you desire.

Q. In the making of specifications can I legally specify a certain brand of culvert, mentioning it by name, without adding the words "or the equal thereto?"

Ans. No; there are many decisions holding that this would be shutting out competition, which the law forbids.

Q. Kindly send, or inform me where I may obtain data showing the results of municipally operated waterworks in cities of the fifth and sixth class.

Ans. See Biennial Report of the State Controller, Hon. A. B. Nye, pages 222, 223, and 224, for the fiscal year ending June 30, 1910.

Q. Our town is contemplating street and sidewalk improvements and we would like to obtain copies of a few ordinances relating to the subject if you can accommodate us.

Ans. Enclosed you will find several ordinances covering sidewalk construction and suitable material for curbs, gutters and roadway.

Q. Under the district assessment plan what proportion of property-owners can stop proceedings, a majority of all the street frontages, or does a majority of any one street stop proceedings as to that street?

Ans. When the council establishes a district to be assessed, the property-owners can protest only as to the extent

of the district, and after hearing the protests the decision of the council is final.

Q. 1. Is it necessary to call the roll in passing a resolution or ordinance?

2. In calling the roll should the name of the president of the board be called?

3. In case an arrest is to be made (for violation of a town ordinance) and the marshal be absent or refuse to make the arrest, what is the proper procedure?

4. Who has charge of building a Carnegie Library, the Town Trustees or Library Trustees?

Ans. 1. It is not necessary to call the roll unless some member desires it. See Section 860 of the Municipal Corporation's Bill. It is advisable and customary, however in passing an ordinance in order to have a record of the vote of each trustee.

2. In calling the roll the president should be called with the other trustees.

3. If the marshal is absent and an



Fire Apparatus  
Police Patrols  
Ambulances

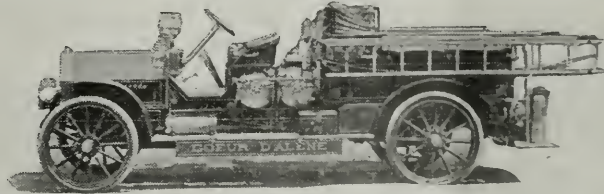

REPRESENTED BY

**RELIANCE AUTOMOBILE CO.**

342-352 Van Ness Ave.

SAN FRANCISCO

# Steiger Terra Cotta and Pottery Works

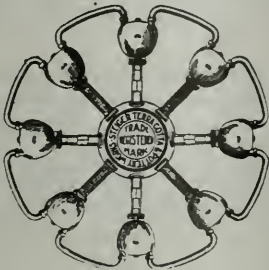

MAIN OFFICE AND YARDS:

City Yard, 18th and Division Streets

Main Office: 729 Mills Building

Phone Douglas 3010

SAN FRANCISCO, CAL.

Factory, South San Francisco

San Mateo County



# Wainwright Galvanized Steel Corner Bar

For Protecting Edges of Concrete Curbs, Steps, Columns, Etc.

The only effective **Concrete Edge Protector** offered to the contracting public

WAINWRIGHT PATENTS—March 9, 1897. November 22, 1898. May 5, 1903.  
March 26, 1907. August 29, 1907. August 2, 1910.

This bar has been in public use for more than ten years as the main feature of the

## WAINWRIGHT STEEL-BOUND CONCRETE CURB

THE BEST IN THE WORLD

OVER THREE MILLION FEET

In use in more than three hundred cities in the United States

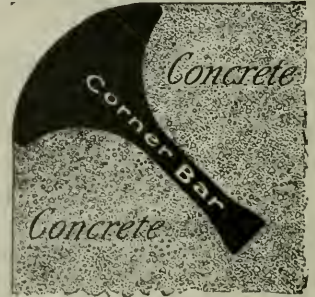

Absolutely Non-Breakable  
Cheaper Than Granite

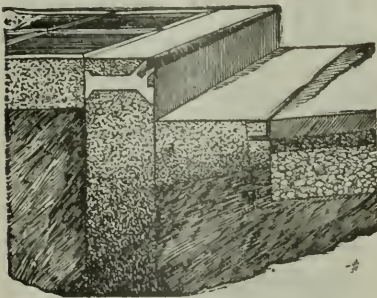

Handsome than Granite and much stronger.

Continuous in Construction, hence Never Out of Line.

**GALVANIZED STEEL CORNER BAR** Prevents Chipping or Breaking on Edges.

This Curb is Mechanically Perfect and Unequaled for Curved Corners.

**THIS CURB WILL STAND HARDER USE AND LAST TEN TIMES AS LONG AS PLAIN CONCRETE CURBING.**

Contractors can make money by laying this curb.

City Engineers can save money by specifying it.

Architects are invited to read pages 242 and 243 "Sweet's Index."

Metal Parts for Sale. Send for Copyrighted Booklet No. 19.

**STEEL PROTECTED CONCRETE CO.**

REAL ESTATE TRUST BUILDING  
PHILADELPHIA, PA.

arrest should be made you may call on a constable. (See Sections 4187 and 4319 of the Political Code.) If the marshal continually refuses or neglects to make arrests when he should, you may remove him.

4. The construction of a Carnegie Library is in the hands of the town trustees, by reason of the fact that the donation is always made to the town. (See Board of Library Trustees vs. City of Hanford, 2 Cal. App. 760.)

Q. The board of trustees have asked me to write you for a copy of an ordinance regulating the speed of automobiles through country towns. Thanking you in advance, I am, etc.

Ans. Enclosed you will find copy of an up-to-date automobile ordinance suitable for your purposes.

Q. The City of Santa Paula contemplates a bond issue under Act 2366, approved March 26, 1895, to raise funds to protect the city from overflow by water. Can you furnish us with the names of any cities that have used this act?

Ans. We regret to say we cannot. However we believe the act is all right.

(NOTE. If any of our readers have

used this act kindly send word to Santa Paula.)

Q. Are there different methods for opening a new street through private property? If so, what is the best method?

Ans. There are three methods in this state.

1. You may exercise the right of eminent domain and condemn the necessary land for street purposes, under the provisions of Part III, Title VII of the Code of Civil Procedure. Los Angeles vs. Leavis, et al., 119 Cal. 164.

2. A municipality may acquire property for corporate purposes by contract. Leeds vs. City of Richmond 102 Ind. 372.

3. The best and most popular method is by use of the street opening act of March 6, 1889, under the provisions of which consideration is given to the benefits (if any) which would accrue to abutting property by reason of opening the new street. This is the method used in nearly all cases.

## What the Cities are Doing

**Fowler** will have a larger hose cart.

**Mayfield** is calculating to pave Main street.

**Santa Rosa** is procuring additional fire hose.

**Sonoma** is about to construct a Carnegie Library.

**Santa Rosa** has purchased an automobile fire engine.

**Fresno** is about to erect a beautiful playground pavilion.

**Napa** trustees have started proceedings to bituminize five blocks.

**Dinuba** citizens are advocating the construction of a sewer system.

**Oxnard** is discussing the acquisition of a municipal water system.

**Visalia** is considering the acquisition of a municipal water plant.

**Fresno** is considering the acquisition of a municipal lighting plant.

**Alturas** is about to erect a two-story brick and stone school building.

**Sonoma** citizens are advocating a bond issue for a new Grammar School.

**Tehama** is about to enforce construction of many blocks of cement sidewalks.

**Burlingame** has employed an expert to devise a system of municipal accounting.

**Alhambra** city school district is about to construct a two story, six room addition.

**Santa Cruz** is considering the establishment of a new system of municipal accounting.

**Vacaville** is about to construct two reinforced concrete bridges over Ulatis Creek.

**Oakdale** voted \$50,000 bonds for a water system on June 3, and \$32,000 for a sewer system.

**Sacramento** bought an 85 foot Seagrave automatic self raising aerial Hook and Ladder truck.

**Coalinga** has voted \$40,000 6 percent 20 year bonds for the purpose of constructing a sewer system.

**Mill Valley** has started proceedings to enforce the construction of 25 blocks of cement sidewalks.

**Willows** is having a sewer system constructed involving the use of the Imhoff method of disposal.

**Huntington Park** is contemplating a bond election for the construction of a water and lighting plant.

**Alameda** is about to erect a reinforced concrete open air swimming bath to cost approximately \$40,000.

**Hillsborough** trustees intend to improve eight miles of their highways with a permanent pavement.

**St. Helena** trustees have started proceedings for street paving under the Local Improvement Act of 1901.

**San Mateo** is considering bids for the construction and installation of a high pressure fire fighting system.

**Redondo Beach** will probably vote soon on the question of issuing \$75,000 bonds for a new grammar school.

**Martinez** will vote on July 22 on the question of issuing \$65,000 bonds for the purchase of water-front lands.

**Redwood City** trustees have adopted plans for the construction of a new city hall costing approximately \$12,000.

**Oakland** officials have awarded contracts for constructing sewer systems for the large district recently annexed.

**Oroville** has accepted an offer of \$10,000 from Andrew Carnegie for the construction of a public library building.

**Modesto** is about to start the construction of a new public library building, the gift of the late Oramil McHenry.

**Tracy** has commenced proceedings for the construction of a sewer system. A municipal water system is also needed.

**Fairfield.** The supervisors are calling for bids for furnishing the new Solano County Court House recently erected here.

**Benicia** citizens are circulating petitions for the calling of a bond election to enable the construction of a new high school building.

**Upland** made a test of its fire fighting apparatus recently and found the fire hose in bad condition. New hose will be secured at once.

**Sacramento** has adopted specifications for the improvement of 148 blocks of streets, necessitating the use of fifty-five trains of rock.

**Pasadena** school authorities are preparing plans for a two story and basement, 8 room, fire-proof grammar school to cost about \$32,000.

**Woodland** will probably have a new County Court House and jail. The supervisors of Yolo County have taken the preliminary step to that end.

**Oakland** will purchase one motor-driven pumping engine and three motor-driven combination chemical and hose wagons for the fire department.

**South Pasadena** is about to commence extensive street paving under the district assessment plan. The work proposed will cost over \$300,000.

**Sacramento** trustees have approved plans for the erection of two new fire engine houses which will be equipped with automobile chemical engines and crews.

**Santa Barbara** officials will call a bond election for \$57,000 with which to construct two bridges over Mission Creek. A lot of street work is now under way there.

**Ontario** is considering the purchase of an automobile chemical combination truck. Another matter agitated is the paving of about a mile of the business streets.

**Lindsay** voted on June 28, on the question of issuing \$75,000 bonds for constructing a sewer system, and \$55,000 bonds for purchasing the privately-owned water system.

**San Bernardino** is preparing plans and specifications for the construction of a large outfall sewer to care for the rapidly growing section in the western part of the city.

**Sacramento** expects to see work commenced within sixty days on the erection of the State Armory building which, according to estimates, will cost in the neighborhood of \$200,000.

**Porterville** has commenced proceedings for holding a special election on the question of voting \$40,000 bonds for the purpose of making extensions to the municipal water system.

**Hayward** firemen have presented a monster petition to the board of trustees requesting a \$10,000 bond election on the question of erecting a new engine house and establishing a fire alarm system.

**Santa Barbara** is considering plans for handling the flood waters of Mission Creek which has a habit of giving trouble during the storm periods. The plan favored by the consulting engineer will involve an expense of \$83,000.

**Santa Monica** city high school district has purchased a twelve acre site for the erection of a new Polytechnic High School. The building and site will cost \$200,000. In addition, \$25,000 will be used for the purchase of playgrounds for the common schools.

**San Mateo** property owners residing in San Mateo Park have petitioned for oil-macadam pavement, to be constructed under the 10 year bond act. The trustees have ordered the engineer and attorney to commence proceedings at once.



### CONDUCTS MUNICIPAL EMPLOYMENT AGENCY WITH SUCCESS

Washington, D. C.—Municipal employment agencies are being conducted with great success in many European countries. Especially is this true in Norway, where the Government endeavors to keep its army of unemployed as small as possible. The following report from Emerson Taylor, American Consul at Stavanger, Norway, is of interest in this connection. 'The Stavanger City Employment Bureau report for the year 1910 has just been made public, and indicates the bureau's increasing utility to both employers of labor and laborers seeking employment. The bureau is a municipal institution, maintained entirely at the expense of the city, under the management of a superintendent appointed by the city government. The salaries and all other expenses are paid out of the city treasury, and no charge is made either to the workmen seeking and finding employment by means of the bureau, or to the employers of labor when workmen are found for them. Although in 1910 a smaller number of men sought employment through the bureau than in 1909, in which year labor conditions were very unfavorable, employment was found for a larger number of men in 1910 than in 1909. The increase in business in the women's department was more marked than in that for men. When both departments were under one management the former was little used, but the city has now appointed a woman as manager.—From the Municipal Journal and Engineer.



## LIST OF RESPONSIBLE FIRMS TO BE CALLED ON TO BID FOR PUBLIC WORK OR SUPPLIES

### WRITE FOR CATALOGS

This list is arranged as a guide for the accommodation of city officials where advertising for bids is not necessary.

#### Accountant

William Dolge, C. P. A., 311 California St., S. F.

#### Architects

W. H. Weeks, 251 Kearney St., S. F.

#### Asphalt Machinery

J. I. Case Thresh'g Mch Co. 616 Myrtle St. O'kl'nd  
A. L. Young M'chy Co. 26-28 Fremont St., S. F.  
Barber Asphalt Paving Co., S. F. & L. A.

#### Arch. Terra Cotta

Gladding, McBean & Co., Crocker Bldg, S. F.  
Steiger Terra Cotta & Pottery Wks, 729 Mills  
Bldg., S. F.

#### Automobile Public Service Wagons

The Thomas B. Jeffery Co., 117-125 Valencia  
St., S. F.

Reliance Auto. Co., 342 Van Ness Ave., S. F.

American La France Fire Eng. Co., 660 Mission  
St., S. F.

American Motors Co., 567 Golden Gate Ave.  
Consolidated Motor Car Co., Van Ness Ave.

#### Bells

W. T. Garratt & Co., 277-279 Fremont St, S. F.

#### Bitulithic Pavement

Warren Brothers Company, Los Angeles, Cal.

#### Blue Prints

So. Cal. Blue Print & Supply Co., 800 L. A.  
Trust Bldg., Los Angeles.

#### Bridge Builders

E. T. Thurston, Jr., Wells, Fargo Bldg., S. F.

#### Concrete Construction

Esterly Con. Co., Inc., 717 Market St., S. F.

#### Concrete Mixers

California Hydraulic Eng. & Supply Co.,  
S. F. and Los Angeles  
Barber Asphalt Paving Co., S. F. & L. A.

#### Constructing Engineers

Fred'k C. Roberts & Co., 221 Sheldon Bldg, S. F.  
Cal. Hydraulic Engineering & Supply Co.,  
San Francisco and Los Angeles  
Geo. E. Dow Pumping Engine Co, S. F. & L. A.

#### Consulting Engineers

Sloan & Robson, Nevada Bank Bldg., S. F.  
E. T. Thurston, Jr., Wells Fargo Bldg., S. F.  
American Engineering Corporation, 57 Post  
St., S. F.

#### Culverts

Cal. Corrugated Culvert Co., Los Angeles and  
W. Berkeley

#### Dump Carts and Wagons

J. I. Case Thresh'g Mch Co. 616 Myrtle St. O'kl'nd  
A. L. Young M'chy Co., 26-28 Fremont St., S. F.  
Watson Wagon Co., Canastota, N. Y.

#### Electrical Plants & Machinery

A. L. Young M'chy Co., Fremont St., S. F.

#### Engravers and Bond Printers

A. Carlisle & Co., 251 Bush St., S. F.  
Schmidt Lith. Co., Second & Bryant Sts., S. F.  
Sierra Art Eng. Co., Front & Com. Sts., S. F.

#### Engineers' Supplies

W. T. Garratt & Co., 277-279 Fremont St, S. F.

#### Fire Engines

Gorham Eng & Fire App Co., 48 Fremont St  
S. F.  
Squires & Byrne Co., 565-567 Mission St., S. F.  
Pacific Fire Extinguisher Co., 507 Montgou-  
ery St., S. F.

#### Fire Hose

Gorham Eng & Fire App Co., 48 Fremont St  
S. F.  
New York Belting & Packing Co., 129-131  
First St., S. F.  
The Gutta Percha & Rubber Mfg. Co., 34  
Fremont St., S. F.  
The Diamond Rubber Co.  
Eureka Fire Hose Mfg. Co., 610 Postal Tele-  
graph Bldg., S. F.  
Squires & Byrne Co., 565-567 Mission St., S. F.  
Bowers Rubber Works, San Francisco

#### Fire Pumps

Geo. E. Dow Pumping Engine Co, S. F. & L. A.

#### Gasoline Engines

Cal. Hydraulic Eng. & Supply Co. S. F. and  
Los Angeles

#### Machine Works

W. T. Garratt & Co., 227-229 Fremont St, S. F.

#### Municipal Accountant

William Dolge, C. P. A., 311 California St., S. F.

#### Municipal Castings

Geo. E. Dow Pumping Engine Co, S. F. & L. A.

#### Municipal Printers

A. Carlisle & Co., 251-253 Bush St., S. F.

#### Municipal Engineers

Fredk. C. Roberts & Co., 461 Market St., S. F.  
Sloan & Robson, Nevada Bank Bldg, S. F.

#### Municipal Lighting Plants

Fredk. C. Roberts & Co., 461 Market St. S. F.

#### Municipal Water Works

Fredk. C. Roberts & Co., 461 Market St., S. F.  
Geo. E. Dow Pumping Engine Co, S. F. & L. A.

#### Office Furniture

H. S. Crocker Co., 674 Mission St.

## LIST OF RESPONSIBLE FIRMS—Continued

**Pavement Materials**

Barber Asphalt Paving Co., S.F. and L. A.  
Warren Brothers Company, Los Angeles, Cal.

**Pumping Machinery & Supplies**

California Hydraulic Eng. & Supply Co., San Francisco & Los Angeles

W. T. Garratt & Co., 277-279 Fremont St., S.F.  
Pacific Fire Extinguisher Co., 507 Montgomery St., S. F.

Geo. E. Dow Pumping Engine Co, S.F. & L.A.

**Playground Apparatus**

A. L. Young Machinery Co., S. F.

**Riggers**

C. A. Blume Con. Co., 185 Stevenson St., S.F.

**Road Machinery**

J. I. Case Threshing Mch. Co., 616 Myrtle St., Oakland, Cal.

The Good Roads Mach'y Co., Ft. Wayne, Ind.

A. L. Young M'chy Co., Fremont St., S. F.

Petrolithic Co., 345 P. E. Bldg., L. A.

Barber Asphalt Paving Co., S. F. & L. A.

**Roofing**

Barber Asphalt Paving Co., S. F. and L. A.

**Rubber Goods**

Squires & Byrne Co., 565-567 Mission St., S.F.

The Diamond Rubber Co.

Bowers Rubber Works, San Francisco

**Sanitary Wiping Rags**

The Raychester Co., 1448 Folsom St., S. F.

**Scrapers**

J. I. Case Thresh'g Mch Co. 616 Myrtle St. O'kl'nd

A. L. Young M'chy Co., Fremont St., S. F.

Petrolithic Co., 345 P. E. Bldg., L. A.

**Sewage Pumps**

Geo. E. Dow Pumping Engine Co, S.F. & L.A.

**Sewer (Concrete)**

Esterly Con. Co., Inc., 717 Market St., S.F.

**Sewer Pipe and Terra Cotta**

Gladding, McBean & Co., Crocker B'ldg, S. F.

Steiger Terra Cotta Co., Mills B'ldg., S. F.

**Sewer Systems**

Sloan & Robson, Nevada Bank Bldg., S. F.

**Sidewalks (Cement)**

Esterly Con. Co., Inc., 717 Market St., S. F.

Steel Protected Concrete Co., Phila., Pa.

**Street Signs**

A. L. Young Mch. Co., S. F.

**Street Sweepers**

A. L. Young M'chy Co., Fremont St., S. F.

**Structural Steel Erectors**

C. A. Blume Con. Co., 185 Stevenson St., S.F.

**Water Meters**

Pittsburg Meter Co., San Francisco

**Water Works Equipment**

California Hydraulic Eng. & Supply Co., San

Francisco and Los Angeles

Geo. E. Dow Pumping Engine Co, S.F. & L.A.

Insulated Wires and Cables

Wire Cloth and Netting

**John A. Roebling's Sons Co.**

S. V. MOONEY, Manager  
MANUFACTURERS OF

**Iron, Steel and Copper Wire Rope and Wire  
of every description**

Phones, Kearny 2426; Home J1220

624-646 Folsom Street

SAN FRANCISCO

Works at Trenton, N. J., and Roebling, N. J.

**SQUIRES & BYRNE CO.**

565-567 Mission St., San Francisco

Dealers in all kinds of

**Double Jacket Fire Hose**

for department uses. Underwriters Linen Hose, Fire Hose Carts and Jumpers. Extinguishers and equipments for Fire Departments, also a full line of mechanical rubber goods of every description. Write for discounts and prices.

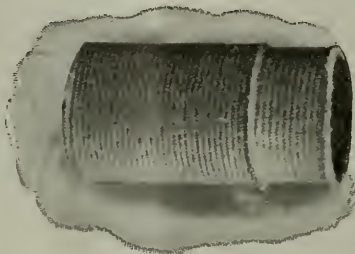

# Eureka and Keystone

## The Standard Water Meters

### Of the Country

Immediate shipment from  
stock carried at  
San Francisco and Seattle

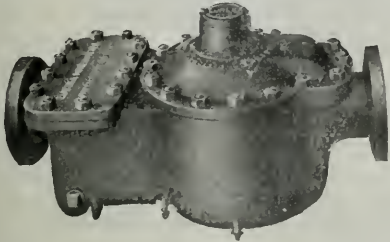

**Eureka**

For measuring large rapidly  
moving volumes

NEW YORK 149 Broadway CHICAGO 337 W. Madison St. KANSAS CITY 6 W. 10th St. COLUMBIA, S.C. 1230 Washington St. SEATTLE 8th & Madison Sts. SAN FRANCISCO 149 New Montgomery St.

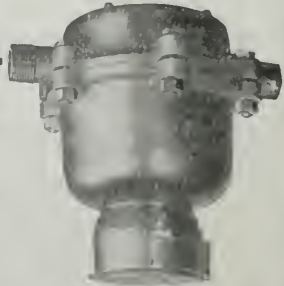

**Keystone**

For house, factory and  
similar service

WATER METER CATALOG 126 FREE

## Pittsburg Meter Co.

General Offices and Works  
East Pittsburg, Pa.

MANUFACTURERS OF WATER METERS AND GAS METERS

# SEWAGE DISPOSAL

OUR APPARATUS is designed exclusively by our  
own engineering department  
and is furnished to meet the varying conditions  
required for various installations.

Send for Catalog.  
It will interest you.



Disposal Plant at Jackson, Mich.  
Our apparatus was used.  
The Temple, CHICAGO  
Singer Building, NEW YORK

## Pacific Flush-Tank Co.

# A. CARLISLE & CO.

## Stationers, Printers and Bookbinders

We specialize in Bonds, Steel Die, Lithographed or Printed, for  
Municipalities or Counties, and the Books and Forms  
required by all Municipal Officers.

251-253 Bush Street

San Francisco, Cal.



## THE IROQUIS LINE

INCLUDES **Asphalt Plants both Stationary  
and Portable  
Macadam Road Rollers  
Tandem Asphalt Rollers  
Asphalt Mixers  
Asphalt and Tar Mixers  
Surface Heaters  
Fire Wagons  
Sand Dryers and all Road Mak-  
ing and Paving  
Machinery and Tools**

The Iroquois Iron Works has been manufacturing MACHINERY and TOOLS for Road Making and Paving for the last twenty years and are used in not only EVERY STATE in the UNION, but in many Foreign Countries.

---

Send for illustrated Catalogue and Booklet of commendatory letters from many SATISFIED users of our products.

---

MANUFACTURED BY  
**Iroquois Iron Works, Buffalo, N. Y.**  
The Machinery Manufacturing Department of  
**The Barber Asphalt Paving Co.**

---

Philadelphia, New York, Chicago, San Francisco, Los Angeles

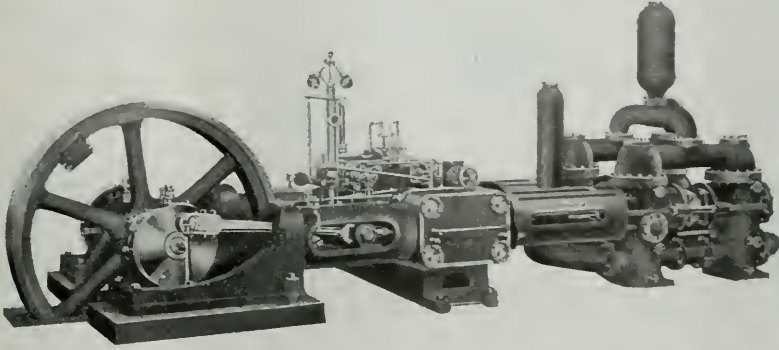

**THE ONLY CONCERN IN CALIFORNIA MAKING  
A COMPLETE LINE OF PUMPING MACHINERY.**

It is not necessary to go East for any type of pump for city service. A California-made pump can be had, whether it be the large pumping engine for supplying a metropolitan population, or a little sump pump to empty a basement.

**Just remember, Mr. City Trustee, if California supplied her own needs every city and every county and every individual in her borders will profit by that much. Why then should you first of all send your city's money outside her borders?**

We maintain a large factory within the limits of one of your League members, and our wage roll goes to the upbuilding of this state.

In that factory we build a larger line of pumping machinery than in any other one factory in this state.

Our engineering force has had wide experience with municipal pumping problems and will gladly let you have the benefit of their experience.

*If interested in a pump or an air compressor  
for any purpose, let us hear from you.*

**GEO. E. DOW PUMPING ENGINE CO.**

237 S. Los Angeles St.  
Los Angeles

417 Sheldon Building  
San Francisco



## THIS Corrugated Iron CULVERT

Is Built of  
American Ingot  
Iron  
99.94% Pure

Some of them are installed in place of culverts which had failed—all of them will safely carry any load traveling the highways, or any fill that may be placed on them. We absolutely guarantee them to do so when properly installed.

American Ingot Iron is not equaled in purity by any other iron or steel—it is 99.94% pure. That is why it resists corrosion.

We use nothing but American Ingot Iron in our construction; we can build anything you want. Let us tell you of the many advantages and possibilities in using our part circles where there is insufficient room for the full circle culvert. We can furnish these in any size desired.

**THOSE CORRUGATIONS GIVE THE STRENGTH**

## California Corrugated Culvert Co.

WEST BERKELEY

LOS ANGELES

## CONSOLIDATED MOTOR CAR CO.

460 Van Ness Ave., Cor. McAllister, San Francisco  
277 12th Street, Oakland

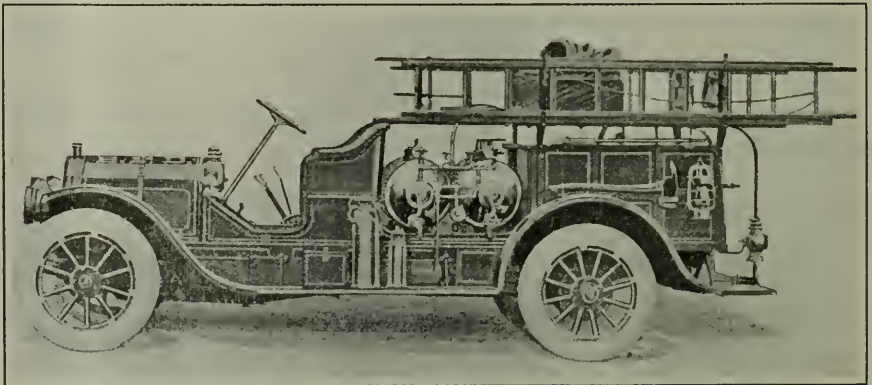

## POPE HARTFORD AUTOMOBILES

All Types of Combinations

Chemical and Chief Wagons

Ambulances and Patrols



# International Municipal Congress and Exposition

Chicago, Ill., U. S. A., September 18 to 30, 1911

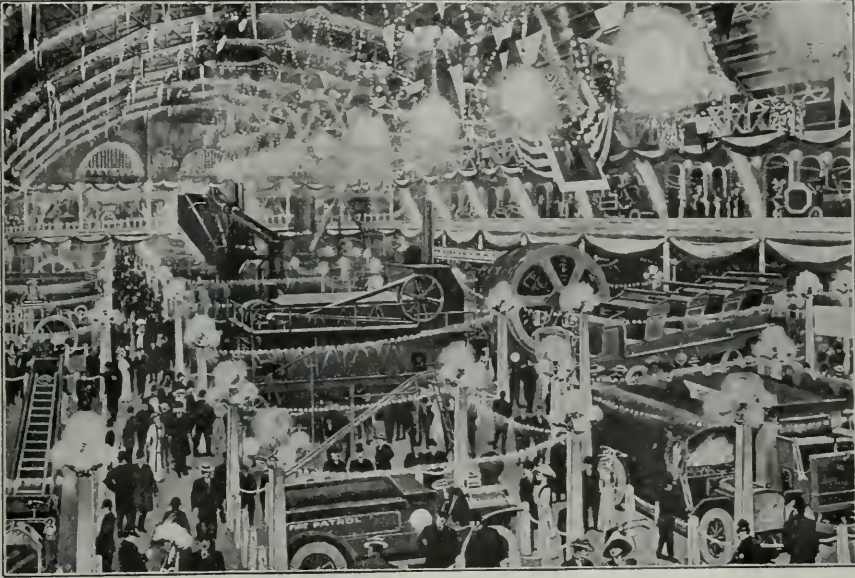

**T**HE CONGRESS will be participated in by Municipal Officials and duly appointed delegates from all of the principal cities of America and Foreign Lands, together with the members of National and International organized bodies concerned in any particular branch of civic work or in clean, economic municipal government as a whole. The world's brightest as well as practical minds will deliver to the Congress papers bearing on that special line of municipal undertaking which they have made their respective studies for a lifetime.

**T**HE EXPOSITION will comprise not only municipal exhibits of every variety, but also the works of the great inventors and manufacturers of the world, who are manufacturing and providing municipal supplies for the universe.

#### Local Forces Participating

The City of Chicago  
Chicago Association of Commerce  
Citizen's Association of Chicago  
Industrial Club of Chicago

Civic Federation of Chicago  
City Club of Chicago  
United Charities of Chicago  
Rotary Club of Chicago

#### Full Information Upon Application to Either of the Undersigned

JOHN M. EWEN, Chairman  
JOHN MAC VICAR, Commissioner General of Congress  
EDWARD H. ALLEN, General Manager of Exposition  
1107 Great Northern Building

CURT. M. TREAT, Secretary  
CHICAGO, ILLINOIS

Or to their Pacific Coast Representatives:  
League of California Municipalities, Pacific Building, San Francisco, Cal.

# Desks, Chairs, Tables and the celebrated Globe-Wernicke Elastic Bookcases and Filing Cabinets

We carry the most complete line on the Pacific Coast.

Send for Catalogs

## H. S. CROCKER & Co.

674 Mission Street

San Francisco



# EUREKA FIRE HOSE



We originated the Seamless Rubber Lined Cotton Hose,  
and manufacture the celebrated brands

## EUREKA      PARAGON      RED CROSS

four ply

three ply

two ply

Eureka Fire Hose bought sixteen years ago can be seen today in regular use in the fire departments of many cities, and in the inflammable paint and dry goods districts.

The only circular and seamless woven fire hose made.

All sizes for every possible use.

## Eureka Fire Hose Mfg. Co., New York

610 Postal Telegraph Building

SAN FRANCISCO

# Worswick Street Paving Company

GENERAL CONTRACTOR

Sheet Asphalt, Macadam,  
Asphalt Concrete, Cement  
Concrete Constructions

Dealer in  
Asphalt, Crushed Rock  
Gravel and Sand

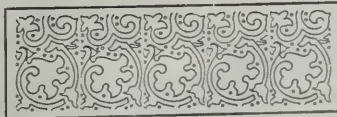

Main Office, Rooms 5, 8, 9, Union National Bank Building

Phone Main 1434

Cable Address "Worswick"  
Western Union Universal Code

Fresno, California



**FREDK. C. ROBERTS & CO.**

(INCORPORATED)

*Mechanical and Electrical Engineers*

MUNICIPAL WATER WORKS  
MUNICIPAL LIGHTING PLANTS  
POWER PLANT EQUIPMENTS

461 Market Street

San Francisco, Cal.

**FIRE HOSE**

**THE GUTTA PERCHA & RUBBER MFG. CO.**

34 Fremont St., SAN FRANCISCO, CAL.

**E. T. THURSTON, JR.**

M. Am. Soc. C. E.

**Consulting Engineer**

713 Mechanics' Institute

Phones Sutter 1683 and C 2895 SAN FRANCISCO

**Specialties**

Design and Supervision of Buildings, Bridges,  
Sewers, Water Works, Highways, etc.

**Concrete Bridges**

Exclusive rights under patents of National  
Bridge Company, the largest in the world.  
Estimates furnished free of charge.

**C. A. BLUME CONSTRUCTION CO.**

Members of Builders Exchange

**Structural Steel Erectors**

**Riggers**

Phone Douglas 324  
185 STEVENSON STREET

SAN FRANCISCO

**ESTERLY CONSTRUCTION CO., Inc.**

**CONCRETE CONTRACTORS**

Buildings, Bridges, Sidewalks, Walls, Floors, Foundations

Room 605, 717 Market St., San Francisco

2136 Center St., Berkeley

TERRA COTTA, PRESSED BRICK, PIPE,  
FIRE PROOFING, ROOFING TILE,  
FLUE LININGS, FIRE TILE,  
LAUNDRY TRAYS,  
ETC.

**GLADDING, McBEAN & CO.**

WORKS  
LINCOLN, CAL.  
--- OFFICE ---  
311-317 CROCKER BLDG., SAN FRANCISCO.

## California Hydraulic Engineering & Supply Co.

### Constructing Engineers

Complete Pumping Plants for City, Fire and Irrigating Systems  
Gasoline Engines, Centrifugal and Deep Well Pumps  
Motors, Concrete Mixers and Supplies

70 Fremont Street  
San Francisco

341 South Los Angeles Street  
Los Angeles



### BUILDING GOOD ROADS

is work that counts. To do this work economically you need a **Fort Wayne Mounted Rock Crusher** with Elevator, Screen and Portable Bin.

**Efficient, Serviceable and Convenient**  
Built in several sizes

Send for catalog of Crushers, Dump Wagons, Road Graders, Steam Rollers, Sprinklers, Sweepers—Everything for Building Roads and Streets.

**The GOOD ROADS MACHINERY COMPANY, Fort Wayne, Ind.**  
Coast Representative, A. L. Young Machinery Co., San Francisco, Cal.

## PACIFIC FIRE EXTINGUISHER CO.

### ENGINEERS and CONTRACTORS

Pumping Plants, Hydrant Systems, Municipal Water Works, Hose and Ladder Carts, Chemical Apparatus  
Municipal Fire Alarm Apparatus, Watchman Time Detector Apparatus.

**Los Angeles**  
1006 Union Trust Bldg.

**San Francisco**  
507 Montgomery St.

**Seattle**  
**Portland**  
**Spokane**

## THE AMERICAN

Used by FIRE CHIEFS of NEW YORK CITY and LOUISVILLE, Ky., because they **can't upset**—and because they will hold together under the terrific strains imposed by that kind of work.

Frame **underslung**, 40 in. wheels, 5 $\frac{3}{8}$ " x 5 $\frac{1}{2}$ " motor. **Krupp & Lemoine** steels and forgings used thruout.

San Francisco Branch

### AMERICAN MOTORS COMPANY

567 Golden Gate Ave.

San Francisco

**WILLIAM DOLGE***Certified Public Accountant --- Municipal Accountant*

TELEPHONE SUTTER 697

Insurance Bldg, 311 California Street

San Francisco, Cal.

**WM. H. WEEKS, Architect**PUBLIC BUILDINGS A SPECIALTY

251 Kearney Street

San Francisco

**SLOAN & ROBSON, Engineers**Reports, Designs, Estimates and Supervision of Municipal  
Light, Water and Sewer Systems

Telephone Kearney 4646

Nevada Bank Building, SAN FRANCISCO

**Create a Demand for YOUR BONDS**  
**It Brings Greater Premiums**  
**ADVERTISE them in**  
**COAST BANKER, San Francisco**

**AMERICAN ENGINEERING CORPORATION**

C. E. GRUNSKY, President

ALL BRANCHES OF ENGINEERING

Mechanics Institute Bldg.

SAN FRANCISCO

**THE CLARA BARTON****Sanitary Wiping Rags**

The Clara Barton Brand of Wiping Rags  
 are Guaranteed to be thoroughly sterilized  
 and disinfected. Telephone Market 2286

**The Raychester Co., Inc.**

1448-1460 FOLSOM ST., SAN FRANCISCO



# COUPLE REST WITH PLEASURE

by including the  
**New Orleans-New York  
Steamship Line**

Between New Orleans and New York in the routing of your ticket East. Costs less than an all-rail route and affords an interesting and delightful diversion on your trip.

## RATES

First class rail to New Orleans and First Cabin steamer to New York, \$	77.75
Round Trip	145.50
One way rail, one way steamer between New Orleans and New York,	70.00
Second class rail and second cabin New Orleans to New York,	65.75

RATES INCLUDE MEALS AND BERTH WHILE ON STEAMER

WRITE OR ASK ANY AGENT FOR DETAILS

# Southern Pacific

## TICKET OFFICES

Flood Building,  
Palace Hotel,  
32 Powell Street,  
Market Street Ferry Depot,  
Third and Townsend Streets Depot,  
Broadway and 13th Street, Oakland

## MECHANICAL RUBBER GOODS

FIRE HOSE  
Chemical  
Hose

EFFICIENCY  
Suction Hose  
Steam Hose

# Diamond

BELTING  
PACKING  
DURABILITY  
Water Hose  
Garden Hose



THE DIAMOND RUBBER CO. of N. Y.

Cor. Second and Mission Sts., SAN FRANCISCO  
Factories, Akron, Ohio

# MUNICIPAL AND CONTRACTORS' MACHINERY

...FOR...

## GOOD ROADS AND STREETS

Street Signs

National Road Machines

Fort Wayne Road Machines

Indiana Road Machines

National Elevating Graders

Elevators—Portable Bunkers

Shares or Cutting Edges for all types of Road Machines

Rock Crushers, Jaw and Gyrotory Type, mounted and unmounted

Screens

Steam Road Rollers

Horse Rollers

Scarifiers

Harrows for oiled roads

Wheeled and Drag Scrapers

Fresno Scrapers

Reversible Road Plows

Street Sprinklers

Sprinkling Attachments

Street Sweepers

Fibre for Street Sweepers

Watson Dump Wagons

Asphalt Machinery

Kettles—Hand Rollers—Tampers

Concrete Mixers

Hoisting Engines

Playground Apparatus

Culvert Pipe

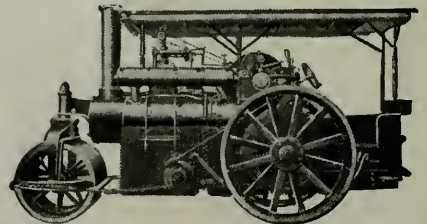

Write us for Catalogues and Estimates

## A. L. Young Machinery Co.

26-28 Fremont Street

San Francisco

California

SANITATION NUMBER

# PACIFIC MUNICIPALITIES



WHAT  
OUR CITIES  
ARE  
DOING

**ENGINEERING**

PUBLIC  
SAFETY  
HEALTH  
CONVENIENCE

**CONTRACTING**

PUBLIC  
UTILITIES  
EDUCATION  
RECREATION

**PUBLISHED MONTHLY**



**33** Seagrave Motor Propelled Fire Machines now in service on the Pacific Coast.  
**21** more being built for this territory.

There are good business reasons for the above remarkable showing, one is—We build nothing but F. D. Apparatus, and **TO ORDER ONLY.**

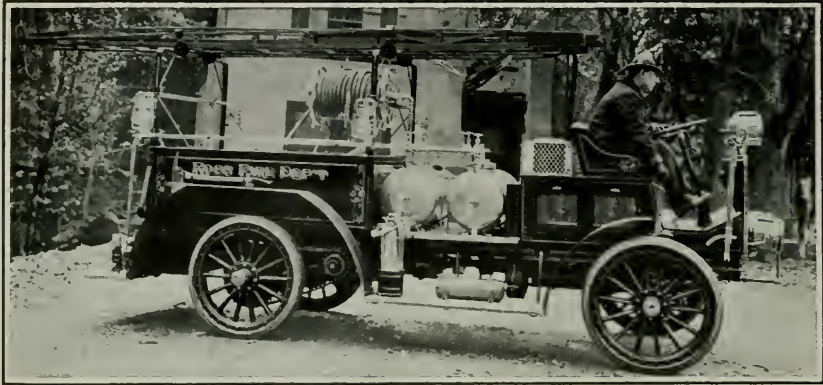

IN SERVICE AT ROSS, MARIN COUNTY, CAL.

Sold by **GORHAM ENGINEERING & FIRE APPARATUS CO.**

48 Fremont Street

San Francisco, Cal.

Branch Stores, Los Angeles, Cal.; Seattle, Wash.

SILENT

LUXURIOUS

3 MODELS

THE NEW  
*Rambler*

Touring Cars, Motor Fire Trucks, Chemical, Hose,  
Police Patrol and Ambulances a Specialty.

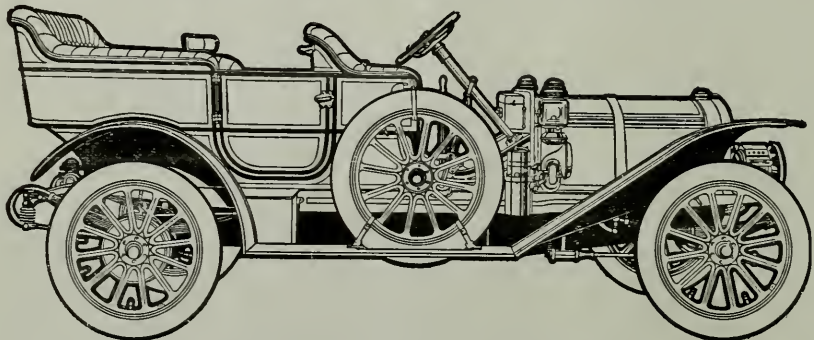

**The Thomas B. Jeffery Co.**

117-125 Valencia St.

**WRITE FOR INFORMATION.**

**San Francisco**

# “THE ROAD IS THE THING”

When built by the CASE Power-steered Road Roller

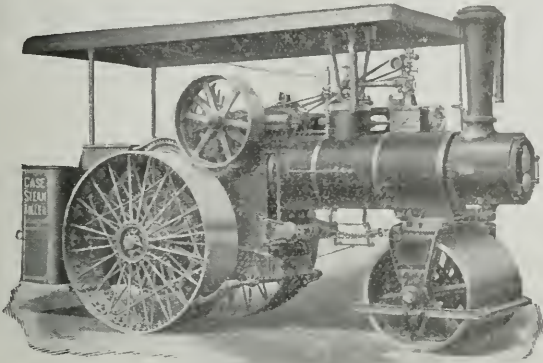

Power steering saves time over hand steering. Time saved is profit. The time saved in using a Case Roller and the extra work accomplished give increased profits to you, Mr. Contractor.

Write for Catalog on Road Roller, Road Machinery and Troy Dump Wagons and Boxes; for Contractors' General Purpose Engine and Municipal Catalog M. Address Road Machinery Dept.

Price, Simple Cylinder, \$2,200

6% discount for cash

J. I. CASE THRESHING MACHINE COMPANY, Inc. RACINE, WIS., U. S. A.

BRANCH OFFICE, 616 MYRTLE ST., OAKLAND, CAL.

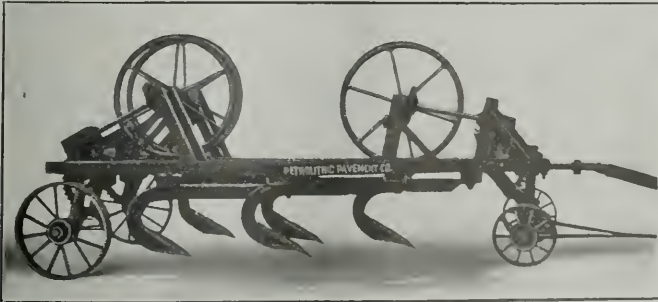

Let us tell you about the new

Petrolithic Gang Road Rooter and Scarifier

THE PETROLITHIC CO.

345 P. E. Bldg.  
Los Angeles

Wherever good Contractors are,

there the Watson dump wagon is known. It's the most used dumping wagon in America, both by contractors and municipalities.



Only one single type of wagon is made in our big factory. All our time and money is devoted to doing one thing, and doing it well. Our printed matter is as high grade as the wagon. Ask for it.

WATSON WAGON COMPANY, Canastota, New York

The First Builders of Bottom Dumping Wagons

California Agencies: San Francisco, A. L. Young Machinery Co. 26-28 Fremont St.; Los Angeles, L. M. Davenport Co.

# “BITULITHIC”

## The Ideal Boulevard Pavement

### “BEST BY EVERY TEST”

☐ BITULITHIC has been adopted as the standard pavement in more than 200 cities, all of which give unqualified praise for BITULITHIC in the earliest as well as the latest cities. More than 15,000,000 square yards BITULITHIC PAVEMENT laid and contracted for in ten years, equal to over 850 miles of 30-foot roadway, shows the rapid increase of yardage and success of the BITULITHIC PAVEMENT.

☐ The following is one of many endorsements that shows that BITULITHIC is the most essential factor in real estate development:

315-316 Dickson Building,  
Norfolk, Virginia, May 7, 1910

Mr. George O. Tenney, Pres.,  
Atlantic Bitulithic Co., Richmond, Va.

Dear Sir:—

As per your request we are offering our opinion of the Bitulithic Pavement and its influence on the value of real estate.

We believe, from comparison with various kinds of paving, that it is the most durable and satisfactory, when constructed in a high grade manner. The Seventh Ward of our city has recently completed eleven miles of Bitulithic; a large expenditure, but justified by the increased tax return from the real estate. Real estate in this ward has increased twenty-five per cent. in value.

Very truly yours,

COLLINS & VAN DENBERGH, INC.

(Signed) Paul T. Collins, President.

☐ BITULITHIC affords a superior foothold for horses in either wet or dry weather and is a sanitary, non-skidding resilient street pavement.

☐ BITULITHIC beautifies the city and enhances the value of property more than any other form of pavement.

==== *Write today for explanatory booklets to* =====

## WARREN BROTHERS COMPANY

59 Temple Place, Boston, Mass. 616 Laughlin Bldg., Los Angeles

———— (REGISTERED IN THE U. S. PATENT OFFICE) ————

“Bitulithic” “Warrenite” “Bitustone” “Bitrock” “Puritan” “Rockphalt”  
“Bituminous Macadam”



NOTE—Every city official in California reads Pacific Municipalities.

# Pacific Municipalities

OFFICIAL ORGAN OF THE LEAGUE OF CALIFORNIA MUNICIPALITIES

Entered at Post Office, Santa Clara, Cal., as Second-Class Matter

VOL. XXIV

TWELFTH YEAR

No. 6

EDITORS - - - H. A. MASON AND WM. J. LOCKE  
EDITORIAL OFFICE - NINTH FLOOR, PACIFIC BLD'G, SAN FRANCISCO  
PUBLICATION OFFICE, - - - SANTA CLARA, CALIFORNIA

## CONTENTS FOR JULY, 1911

The Sanitary Engineer and the Public Health	<i>William F. Snow, M. D.</i>	221
New Development in Sewage Purification	<i>Ned D. Baker</i>	223
A New Method of Handling Sewage Sludge	<i>Dr. Karl Imhoff</i>	225
The Imhoff Sewage Reduction Tank	<i>C. E. Grunsky</i>	227
Proposed Imhoff Sewage Disposal Tanks for Winters, Cal.		229
Disposal of Sewage on Sewage Farms	<i>Chris. P. Jensen</i>	234
The Failure of Concrete Pipe for Sanitary Sewers	<i>C. H. Rice</i>	239
The Sieben System for Cleaning and Disinfecting Sewers		244
Health Department Inspection of Garbage Cans		247
The Problem of Small Sewage-Disposal Works		248
EDITORIAL		
Program for the Santa Barbara Meeting		249
Our Next Number		249
Improvement Act of 1911		249
Rids City of Empty Tin Cans		250
The Cost of Disease		250
Questions and Answers		251
Sanitation Statistics from 115 California Municipalities, July, 1911		253
What the Cities are Doing		255
Plague of Flies		255

Published Monthly. Yearly Subscription, \$2.00 in Advance. Single Copies, 25 Cents

ADVERTISING RATES ON APPLICATION

Address all Communications to "PACIFIC MUNICIPALITIES" Pacific Building  
San Francisco, California

# LEAGUE OF CALIFORNIA MUNICIPALITIES

Organized 1897

## — OFFICERS —

President	-	-	(Mayor of Berkeley)	-	BEVERLY L. HODGHEAD
First Vice-President	-	-	(Councilman of San Diego)	-	A. E. DODSON
Second Vice-President	-	-	(Mayor of Santa Cruz)	-	T. W. DRULLARD
Secretary	-	H. A. MASON	Ass't Secretary	-	WM. J. LOCKE

## STANDING COMMITTEES

EXECUTIVE—	Beverly L. Hodghead; H. A. Mason; S. C. Eyans, Mayor of Riverside; Percy V. Long, City Attorney San Francisco; W. P. Butcher, City Attorney Santa Barbara.
LEGISLATIVE—	W. F. Hyde, Palo Alto; J. O. Walsh, San Francisco; J. H. Strait, Redlands; F. H. Allbright, Red Bluff; B. L. Barney, Hanford.
JUDICIARY—	C. N. Kirkbride, San Mateo; P. G. Sheehy, Watsonville; Stephen G. Long, Long Beach; R. E. Rhodes, Madera; Wm. J. Carr, Pasadena.
ENGINEERING—	Chris. P. Jensen, Fresno; C. H. Pieper, San Jose; A. P. Noyes, Vallejo; R. C. Tumelty, Stockton; O. E. Stewart, Anaheim.

Secretary's Office and Headquarters of the League, - Pacific Building, San Francisco

## INFORMATION BUREAU

The League of California Municipalities maintains, in connection with the Secretary's Office, an Information Bureau where the officials of the municipalities belonging to the League can secure information on all subjects relating to municipal affairs.

## MEMBERSHIP

Alameda	Imperial	Rio Vista
Albany	Jackson	Riverside
Alhambra	Lakeport	Sacramento
Anaheim	Lemoore	San Bernardino
Antioch	Lindsay	San Buenaventura
Arcata	Livermore	San Diego
Azusa	Lodi	San Francisco
Bakersfield	Lompoc	San Jose
Benicia	Long Beach	San Leandro
Berkeley	Los Banos	San Luis Obispo
Biggs	Los Gatos	San Mateo
Bishop	Loyalton	Santa Ana
Black Diamond	Madera	Santa Barbara
Burlingame	Martinez	Santa Clara
Calistoga	Merced	Santa Cruz
Chico	Mill Valley	Santa Maria
Coalinga	Modesto	Santa Monica
Colton	Monterey	Santa Paula
Colusa	Mountain View	Santa Rosa
Compton	Napa	Sebastopol
Concord	National City	Selma
Coronado	Newman	Sierra Madre
Corona	Newport Beach	Sisson
Covina	Oakland	Sonoma
Crescent City	Oceanside	Sonora
East San Jose	Orange	South Pasadena
Elsinore	Oroville	South San Francisco
Emeryville	Oxnard	St. Helena
Escondido	Pacific Grove	Stockton
Etna	Palo Alto	Suisun City
Eureka	Pasadena	Susanville
Fairfield	Petaluma	Tehachapi
Ferndale	Piedmont	Tracy
Fort Jones	Pinole	Tulare
Fowler	Placerville	Vacaville
Fresno	Pleasanton	Vallejo
Gilroy	Point Arena	Visalia
Glendale	Pomona	Watsonville
Hanford	Red Bluff	Whittier
Hayward	Redding	Willits
Hercules	Redlands	Winters
Hermosa Beach	Redondo Beach	Woodland
Hillsborough	Redwood City	Yreka
Huntington Park	Richmond	

Every city belonging to the League of California Municipalities is entitled to a free copy of this magazine every month for each of its officials; if not received kindly notify the Secretary. See that your City is in the above list.

# PACIFIC MUNICIPALITIES

A Journal for Progressive Cities

Vol. XXIV

JULY 31, 1911

No. 6

## THE SANITARY ENGINEER AND THE PUBLIC HEALTH

BY WILLIAM F. SNOW, M. D., SECRETARY CALIFORNIA STATE BOARD OF HEALTH

IN August, 1894, Japan began her war with China. Ten years later she declared war against Russia. The following morbidity and mortality rates for these two wars are well worth serious thought:

DISEASES	Number of cases and deaths per 1,000 men engaged			
	Chino-Japanese war 1894-5		Russo-Japanese war 1904-5	
	Cases	Deaths	Cases	Deaths
Cholera .....	82.77	50.86	0.00	0.00
Typhoid .....	37.14	10.98	9.26	5.00
Malaria .....	102.58	5.29	1.96	0.67
Totals .....	222.49	67.13	11.22	5.83

It will be seen that, while the case-mortality in 1904-5 was fifty-one per cent for these three diseases as against thirty per cent in 1894-5, the army had 211 less men per thousand ill with these diseases in 1904-5 than in the war ten years before. To ascribe this great saving of life and prevention of disease to any single factor, or to administrative measures alone, would be unwarranted but the facts themselves are remarkable, and serve to point the question, Has similar progress been made in reducing death and illness from these diseases among civil populations?

There is, perhaps, no common basis on which to compare morbidity and mortality rates for armies and civil populations. The army problem deals with maximum conditions of crowding, fatigue, unknown water supplies, limitation of sanitary facilities, etc., but the soldiers themselves are specially selected for physical efficiency, are all adults, and are under strict military discipline. On the other hand, the civil population has an opportunity to safeguard its water supplies, sanitary and housing conditions, etc., but must deal with all classes and ages of people, and has practically no administrative control over the customs and carelessness of individuals. Nevertheless, demonstrations, such as that of Japan in reducing the world's average army record of four deaths from disease for one from wounds to



## PACIFIC MUNICIPALITIES

one death from disease to four from wounds suggest that more rapid progress should be made in stamping out preventable diseases among civil populations.

In California we have until recently failed to keep complete morbidity and mortality statistics, but in the following figures for deaths from the diseases given above are authentic, and the estimates of cases are conservative:

DISEASES	Number of cases and deaths in California									
	1906		1907		1908		1909		1910	
	Cases (estimated)	Deaths (actual)	Cases (estimated)	Deaths (actual)	Cases (estimated)	Deaths (actual)	Cases (estimated)	Deaths (actual)	Cases (estimated)	Deaths (actual)
Cholera . . . . .	0	0	0	0	0	0	0	0	0	0
Typhoid . . . . .	5,940	594	5,400	540	5,580	558	4,610	461	4,710	471
Malaria . . . . .	5,000	100	4,000	80	3,500	70	5,600	112	5,650	113
Totals . . . . .	10,940	694	9,400	620	9,080	628	10,210	573	10,360	584

The United States Conservation Commission reported that *eighty-five per cent of typhoid fever and eighty per cent of malaria are preventable*. If that is so, more than 41,304 (perhaps 80,000) persons in the past five years have had malaria or typhoid in California needlessly, and 3,000 are filling unnecessary graves.

It will be noted in the California deaths given above that malaria has remained nearly stationary in annual number during the past five years, while typhoid fever has decreased approximately twenty per cent. This reduction has in a large measure been due to the sanitary engineer. Just as the armies of the world have been slow to recognize the importance of giving the ranking medical officer equipment, men, authority over all sanitary and medical matters, so the public has been slow to realize that the great scientific truths of preventive medicine can only be successfully applied by specially trained officers who have equipment, authority, and the active co-operation of the citizens. The last ten years have witnessed an awakening in this regard which has been unprecedented. Japan's remarkable demonstration of medical and sanitary science, applied to military requirements, has been paralleled by the United States' application of these same scientific principles to civil populations under military rule in Panama and the Philippines. Isolated states and cities have in recent years made great strides toward demonstrating that civil populations under civil rule may also yield equally remarkable results. The sanitary engineer has perceived what might be accomplished by properly fortifying our cities against the entrance of water-borne diseases through water supplies and their escape through sewage. He has demanded that cities provide him with sufficient funds to build filtration plants and sewage disposal works, and to employ trained superintendents to control them when built. Cholera has found itself repulsed by these defenses; typhoid has been cut off from its chief method of attacking cities, but being more resourceful than the cholera "germ", continues its warfare through milk supplies and by other means; malaria, being a mosquito-borne parasite, has its activity limited by water and sewage facilities only in so far as breeding places for mosquitoes are eliminated by the better drainage afforded.

California cities are rapidly providing themselves with water purification, sewage and garbage disposal plants. Competent engineering advice has not always been sought, and some municipal heartaches have resulted; but the need for the sanitary engineer in public health work has been established.

The State is well supplied with competent practicing sanitary engineers, and once the people have been helped to thoroughly understand their sanitary needs, they will not fail to avail themselves of the services of experts in providing for these needs.



## NEW DEVELOPMENT IN SEWAGE PURIFICATION

EXTRACT FROM AN ARTICLE BY NED D. BAKER FORMERLY ENGINEER INSPECTOR, CALIFORNIA STATE BOARD OF HEALTH

In the August, 1910, number of the bulletin issued by the State Board of Health, the subject of "Septic Tank Effluents" was briefly pointed out. The old theory, still held by an isolated few, that the "septic tank" is all that is necessary in the treatment of sewage, is rapidly being disproven. The hope that it would solve the "sludge disposal problem" finally is meeting with disappointment the country over.

In an article in the Journal of the American Medical Association of December 10, 1910, Dunbar, a German student of sewage disposal, is quoted on this subject as follows:

"At first it was maintained that the sludge was entirely liquified and gassified; then that it was reduced by fifty per cent; and, as a result of the most recent investigations of which I am aware, it is stated that the amount of sludge is not reduced by more than nine per cent."

That the septic process will always occupy a large and important place in sewage purification of California there seems little doubt. In many places the sewage is used during the dry season for irrigation, and in most of these the tanks are successful for removing and storing the solids for long periods of time. Especially is this true of smaller communities, where the tanks have little or no close supervision.

The records at this office show that of sixty-three California municipalities

that are now operating, or will soon build, septic tanks, only five are making any provision for further purification of the effluent. The water from thirty-nine of the tanks is used for irrigation for most of the year, eight of them discharge into the ocean or other salt water and eleven run their effluents into inland streams or sloughs. Those five towns that will further purify their sewage are all doing so to avoid the possibility of creating a nuisance into the streams into which they discharge. On the other hand, a dozen or more cities and towns of the State discharge their sewage directly into streams without any purification.

In the March, 1911, special edition bulletin issued by the State Board of Health, several plants for treating the septic effluent are described. These new plants mark a new era in sewage purification in California. A little over a year ago nothing of the kind was to be found in the State, and the conditions leading up to the building of these plants furnish an interesting study.

In every case the primary object was to prevent a nuisance rather than because of sanitary reasons. It is a well known fact that if a putrescible effluent such as that from a septic tank, be turned into a stream that has not enough water to oxidize it, a nuisance will result. In designing the work for aerobic

treatment of the sewage, the effort is made to carry it through the final stages of oxidation so the effluent will be stable.

The two distinct types of design represented are the contact beds and the sprinkling filters. Both are designed to bring the partially purified sewage in to touch with rich cultures of nitrifying bacteria and artificially produce the conditions best suited for the growth of these organisms. They are both purely biologic in their action. As the septic tank represents intensive action of anaerobes or putrefactive organisms, so the contact beds and trickling filters are made the field of intensive action of the aerobic forms or those that use air and oxidize the organic matter.

Just what is the fate of the pathogenic or disease-producing germs in this process has not been definitely decided. But it is very probable that few of them escape. There is, however, a wide variation in opinions on this point.

*Contact beds.* This form requires the building of a water-tight receptacle, which is filled with coarse material, such as broken stone, cinders, clinkers or the like. The filling material is selected with a view of getting a large total area of surface exposed, and a material that will drain quickly and will not break down and thus cause clogging of the filter.

The beds are operated in "cycles" that is to say, a bed is filled and allowed to stand full for several hours, the time depending on temperature and other conditions. Then it is emptied and stands empty for several hours before refilling. Large plants in the eastern part of the United States are operated in from two to four such "cycles" in twenty-four hours. This necessitates having

separate units so one set can rest while the others receive the sewage.

The large number of surfaces in the filling material become covered with a slimy film, which is really a very rich culture of bacteria. When the sewage is brought into contact with these films there takes place a rapid nitrification of the organic substances in it. A process that under ordinary conditions would require several days or weeks is accomplished under these highly favorable conditions in a few hours. When the beds are empty and the voids filled with air the culture films of bacteria have a chance to recuperate, as it were, because they require a great deal of oxygen in their life processes.

*Double contact.* This is the treating of the sewage in two contact beds run in series, the second receiving the effluent of the first.

*Trickling filters.* This form of aerobic treatment depends on the same general principles as that by contact beds, but differs in its mode of application. The trickling filter is essentially a bed of coarse material, on to which the sewage is thrown in a fine spray. The only one the writer has seen in operation in California is at the Sacramento County Hospital, near Sacramento. Unlike the contact bed, the trickling filter has no tight walls. The continuous and free passage of air through the filter during operation is conducive to the best results.

The sewage, being aerated by the spray application, trickles down over the surfaces of the broken stone or other filling, being brought into intimate contact with the bacteria cultures in the slimy films on the rocks, also being continuously in contact with the air in the interstices. The material is so coarse that little or no mechanical strain-



ing is expected, the bacterial action being almost wholly responsible for what purification takes place.

In the experiments made on purification of the Boston sewage it was found that as good results could be had from sprinkling filters as from contact beds, and that a higher rate of filtration could be used. They require more constant attention, and under some circumstances are less desirable for this reason.

*Slow sand filters.* Unless the solids are first largely removed and the sewage put through some preliminary process before being put onto the sand filters, considerable difficulty is likely to result from clogging.

In this State natural sand and gravel beds are in many cases available. These have rarely been underdrained by tile, and owing to difficulty in collecting fair samples of the effluents the degree of purification effected by them can rarely be studied. They are frequently farmed during a part of the year and so the system resolves itself into a combination

of sand filtration and broad irrigation in such cases.

On the whole, we seem to be on the eve of a widespread and radical change in our ideas and policies regarding sewage disposal. The more complete purification processes are being studied and fitted by our engineers to California conditions. These conditions differ in many ways from those in the older states where such processes have been used, and the California engineers have been at a distinct disadvantage in not having the results of local experiments. The plants being designed without this data, and being fitted to local conditions purely on theory, it will not be surprising if some of them fall short of the results expected of them. But these engineers are deserving of much credit as pioneers in this most important branch of the profession in California.

The works they have installed will be watched with interest, and the future progress to be made along these lines in our State will owe much of its success to these first beginnings.



## A NEW METHOD OF HANDLING SEWAGE SLUDGE

A SYNOPSIS OF THE ARTICLE PUBLISHED IN THE ENGINEERING RECORD OF DEC. 10, 1910.

BY DR. KARL IMHOFF AND HIS ASSISTANT, CHARLES SAVILLE

Sewage Sludge may be defined as being the solid matters in sewage which may be separated by sedimentation or other means.

In the case of "septic tanks" the sludge is allowed to remain in the tanks for long periods with the result that the sewage itself tends to become septic and the effluent often contains fine suspended matters consisting of partly decomposed sludge.

This article is intended to briefly de-

scribe the method of handling sewage sludge in the Emscher District of southwestern Germany, where the sewage is discharged into small streams after sedimentation in specially designed tanks.

The sludge particles slide down the V shaped sides of the clarification tank through the narrow slots in the sludge well, where biological actions of decomposition begin. The decomposing action in this tank differ in many respects from those in the septic tanks which

have a current of sewage passing through them. The existence of these actions is shown by the rising gases which result from the decomposition of the organic substances. These gases consist almost exclusively of marsh gas and carbon monoxide, both of which are known to be odorless.

The sludge is removed every four weeks, through a pipe at the deepest point in the room (b) Fig. 1 in the following article. To use the sludge-room to the best advantage the sludge should be allowed to accumulate until its upper surface is in the vicinity of the slits (g) before any is drawn out. Only so much sludge should then be removed as corresponds to a "decomposing time" of at least four weeks. A portion of the sludge will rise on the sides by reason of containing an extra amount of the gases but this gives no trouble.

The clarification of the sewage is mechanical, the decomposition of the sludge is biological. The biological organisms must first of all become active. When the tank is put into operation a longer time is required for the decomposition of the sludge than after the decomposing-room has become "ripe". The decomposition is generally better the second year than in the first. As in the case of digestion which goes on in the body of animals, the decomposition must be accompanied with a regular supply of fresh material and a removal of the decomposed substances. Therefore the sludge must not be removed completely at any time. Likewise the operation must not be interrupted for any length of time. It may be said, however, that errors in operation are not easily made.

If the decomposing-room is properly arranged everything may be left to nature. It is only necessary to draw off the sludge at the right time and in the right amounts. Very little consideration need be given to the room.

The liquid sludge, after remaining the necessary time in the decomposing-room, changes materially from its original condition, and corresponds in many respects to ordinary septic sludge. It decreases in quantity and becomes a black uniform porous mass with a slight odor of tar or burned rubber. At least half of the organic matter has been converted into gas, while the remainder is no longer capable of producing objectionable odors. This sludge contains very little water as compared with septic sludge, the water content averaging 75 per cent.

The sludge is next drawn off at the proper time and drained on beds made of slag or other porous material and underdrained by small pipes. Most of the water drains off the first day. The sludge dries in a few days, a week being the average where there is much rain. The drying beds remain effective a long period and fine sand or cinders is spread on the surface after using.

After drying, the sludge has a very loose structure and is permeated with fine pores. Of the material it was originally composed nothing but hair and straw are recognizable. It disintegrates in the air and being easily digested by plants, it is suitable for agricultural purposes. In this form of tank, which has a depth about as great as its diameter, the troublesome sulphuretted hydrogen gas develops only in small quantities.

## THE IMHOFF SEWAGE REDUCTION TANK

BY C. E. GRUNSKY\*

In the ultimate disposal of sewage, other than by immediate dilution in large bodies of water, the advantage of a preparatory treatment is being recognized. The need of such a treatment brought the septic tank to the front some years ago and by its use, with a relative small amount of attention, from 25 to 50 per cent of the solid matter in ordinary sewage was removed and by septic action the remainder, the effluent from the tank, was brought into a condition adapted for further treatment.

The effluent may be disposed of in various ways. It may be used for irrigation, or it may be filtered, or it may be sprinkled upon coke beds. In some cases it is discharged without additional treatment into the ocean or other adequate bodies of water.

As the liquid discharged from septic tanks is foul smelling, and as the sludge taken from the septic tanks is also malodorous and is a material not easily disposed of without creating more or less of a nuisance, engineers have sought for some means of accomplishing sedimentation of the solid matter in sewage and its reduction to a harmless and inoffensive condition without allowing the sewage to become septic. There has, in other words, been a strong endeavor to find means of keeping the sewage fresh while depriving it of its solids instead of allowing it by long retention in a tank to become septic and correspondingly foul smelling.

This endeavour has led Dr. Owen Travis to the invention of a tank which has probably thus far found its best expression in the sewage treatment works at Norwich, England. The plant at

that point was constructed according to the design of Mr. A. E. Collins, M. Inst. C. E. The essential principle of the tank, as there used, is illustrated in Fig. 1. This shows a cross-section of the Tank. The sewage flows in compartments in a direction perpendicular to the plans of the section. At the bottom of these longitudinal tank compartments are narrow openings through which any solids settling out of the slow moving sewage will find their way into the lower reduction chamber. By an

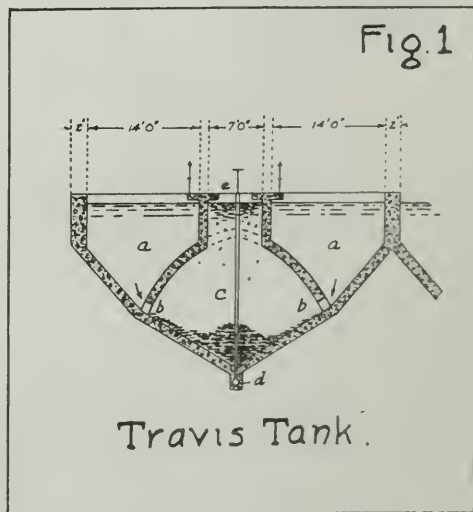

arrangement which permits a flow of a small amount of the liquid in the reduction chamber out into a supplemental treatment tank, a slight downward current is maintained from the compartments containing fresh sewage to the reduction chamber.

It will be noted that the shape of the tank is such that the decomposition-gases which rise in the reduction chamber can not pass up through the fresh sewage. This is an essential feature.

\* President of the American Engineering Corporation.



A scum forms on top of the liquid in the reduction chamber. The sludge is drawn off from the bottom in pipes not shown in the section.

Very similiar in its general arrangements to the Travis tank is the later tank perfected by Dr. Karl Imhoff and now in successful use at many points in the Emscher Valley, Germany, and already reported as about to be installed at a number of places in the United

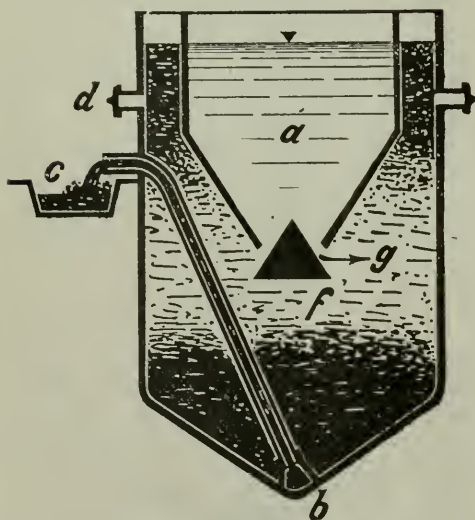

FIG. 2. SECTIONAL VIEW OF "IMHOFF TANK"

States, as at Atlanta, Georgia, and for Montclair and neighboring New Jersey towns.

This tank is illustrated in diagrammatic form in Fig. 2. The fresh sewage flows in compartment (*a*). The solids sink to the bottom of compartment (*f*). The gases which rise in the reduction chamber accumulate at and are let off at convenient points. The scum, which

corresponds to thoroughly decomposed sludge, can be drawn off through specially provided outlets (*d*), which are said, however, not to be essential. The sludge is drawn off through a conduit (*bc*) with outlet somewhat lower than the surface of the liquid in the tank.

It is claimed for the Imhoff tank that it will remove from the sewage as high as 95 per cent of the matter capable of settling out; that very little sulphuretted hydrogen is generated in the treatment; that the fresh sewage effluent is in good condition for further treatment by any of the ordinary methods of filtration, application to land, or otherwise; and that both the effluent and the sludge are nearly free from foul odor. The sludge loses its water contents rapidly and within a few days after being drawn from the tank is in a spadeable condition.

The tanks, as in use, are so proportioned that the fresh sewage will flow through them at a velocity of less than one foot per second and so it will not remain in them more than about two hours.

Imhoff tanks are to be used in connection with the sewage disposal works of Atlanta, Georgia; also at Montclair, New Jersey, and the first in California, so far as known, are about to be installed at Winters. The Imhoff tank is full of promise and will no doubt in many cases, particularly under such conditions as prevail at our inland towns, become a desirable feature of sewage disposal works.

**\*PROPOSED IMHOFF SEWAGE DISPOSAL TANKS FOR WINTERS, CAL.**

The new sewage disposal works for which money has been provided by bond issue, and which will soon be built for the town of Winters in Yolo County, will consist, in part, of a two-unit sewage tank of the Imhoff type. Bids for this work will be received August 1st and it is expected that construction will start immediately thereafter.

The operation of the Imhoff tank differs somewhat in principle from that of the septic tank of the ordinary type, and the designs for the new tank, at Winters, deserves more than a passing glance because, so far as the information at hand shows, this will be the third Imhoff tank built in America, and the first one west of Chicago.

Imhoff tanks are now being installed at Atlanta, Georgia and at Philadelphia, Pa. The recommendations there were made after careful study of local conditions and of the work of such tanks in Germany.

The Imhoff or Emscher type of sewage tank is a form that was developed in the Emscher Sanitary District of Germany as a result of the studies of Dr. Karl Imhoff, Chief Engineer for the district.

It uses a principle similar to that of the septic tank for the digestion of the sludge, but with variations that tend to eliminate the objectionable features of that tank. The essential characteristic of the Imhoff tank is that it immediately separates the solids from the incoming sewage. These pass at once through slots in a hopper-shaped floor into a separate chamber or sludge well. The liquid part of the sewage passes on, and,

being in a fresh condition, is best adapted to any method of final disposal. If sufficient dilution water is available, the settled sewage is turned directly into it, as the chief cause of nuisance, in such cases, is the presence of solids.

The slots in the floor of the settling chamber are so arranged that gas bubbles cannot pass up through them, and by this means, the turbidity often present in septic tank effluent is avoided.

The turbidity of a septic effluent is caused by bubbles that constantly rise through the passing sewage flow and carry up finely divided particles of sludge to pass out with the effluent. Some Eastern observers have found that when warm weather begins to bring more violent bacterial action, the effluent of the septic tanks contained more solids than the incoming sewage. This turbidity is not harmful in itself, except as it gives trouble in clogging of sand beds or filters, or clogging the pores of loose soil irrigated by the effluent.

The Imhoff tanks are made much deeper than the septic tanks, the bottom of the sludge-well being from 20 feet to 30 feet below the water level. The sludge has therefore been digested under the considerable pressure of from 1½ to 2 atmospheres. Dr. Imhoff claims that this fact has considerable influence on the chemical processes and determines, in a measure, the kinds of gases produced.

There is a constant supply of fresh solids being brought in and the process of purifying them goes on continuously.

The gases given off are said to be mainly of the marsh-gas series and non-

odorous and inoffensive. In the tanks, so far observed, hydrogen sulphide, so prevalent in the gases from septic tanks, seems to be lacking.

**RESULTS OF OTHER TANKS.** In an article in the "Engineering News" of December 1, 1910 and again in the "Engineering Record" of December 10, 1910 the principles of the design and operation of the Imhoff Sewage Tank are very fully explained and the results of their operation in Germany are given. The chief advantages claimed for this form over the old septic tanks are summed up as follows:

(1) The plant in operation does not cause a nuisance from objectionable odors, either from the gases from the tanks or from the removed sludge.

(2) The effluent, being delivered in a non-septic condition, is much less offensive and better adapted to any method of final disposal.

(3) The bubbles from the "working" sludge, being unable to rise through the chamber where the sewage passes, do not cause turbidity of the effluent so common in septic tanks in times of violent bacterial action.

(4) The sludge after being treated is comparatively inoffensive, dries out readily and is easily disposed of.

**EXPERIMENTAL TANKS.** Experimental tanks of the Imhoff type are being operated by the city of Philadelphia and by the Sanitary District of Chicago. The full results of these investigations are not available but it is understood the work of the tanks was found to be very satisfactory.

Dr. Arthur Lederer, Chief Chemist of the Sewage Experiment at Chicago stated in a recent interview that the reduction of sludge in the tank had not been what the results in Germany would lead one to expect. That, so far, the

results at Chicago showed the sludge from the experimental Imhoff tank did not greatly differ apparently from the dry scum off the septic tanks. The Imhoff tanks had, on the whole, done good work in removing and storing the solids and he considered the effluent better in many ways than that of the experimental septic tanks. The Imhoff tank used there, is a small circular one, very similar in design to that described in the "Engineering Record" of August 28, 1909, Vol. 60, page 249.

**WINTERS DESIGNS.** In choosing this type of sewage tank for Winters, the Engineers made every effort to insure a design properly fitted to local needs and conditions. To this end, the plans and specifications for the tanks are being passed on, by Dr. Imhoff himself, and by Dr. Rudolph Hering, the Consulting Sanitary Engineer of New York City, who recommended and installed the Imhoff tanks at Atlanta, Georgia.

## DETAILED DESCRIPTION OF IMHOFF TANKS AT WINTERS

**CAPACITY.** The present population of Winters is about 1500. The disposal works were designed to accommodate twice this number, to avoid the necessity of immediately enlarging. The estimated daily sewage flow is 75 gallons per capita or 225,000 gallons for 3,000 people. This is an average hourly flow of about 10,000 gallons. The sedimentation chambers are designed to give a storage period of three hours and have a capacity of 4,000 cubic feet equivalent to 30,000 gallons.

The sludge chambers are made large enough to store sludge for a period of six months. There are two such chambers, circular with a diameter of



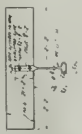
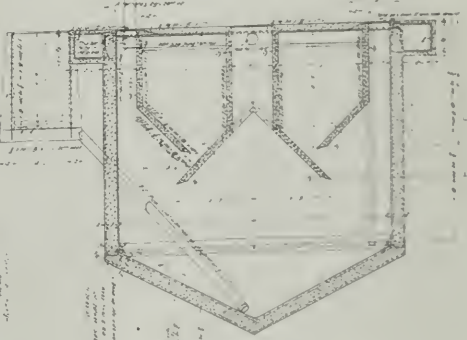
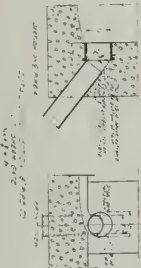
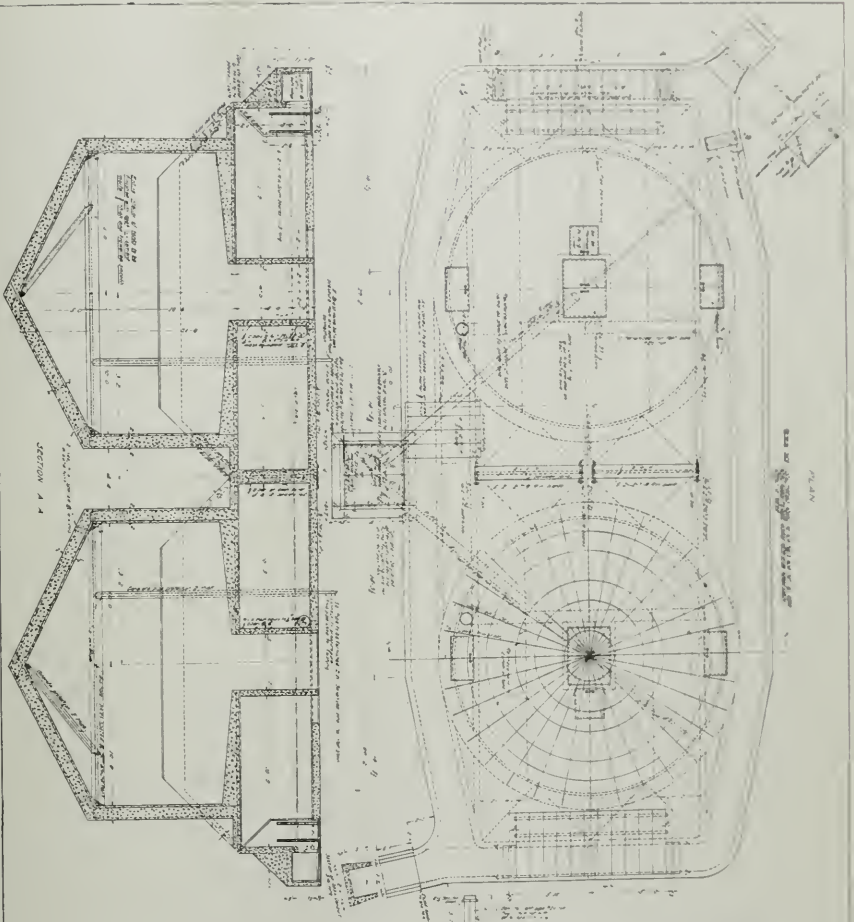

IMPORTANCE PURIFICATION TANKS  
 WINTERS SEWAGE DISPOSAL WORKS

20 feet, and an effective depth for storing sludge of about  $6\frac{1}{2}$  feet. The sludge capacity amounts to 1950 cu. ft. for each tank or a total of 3900 cu. ft. Estimating the amount of sludge at .007 cu. ft. per capita per the amount from 3000 persons would be 21 cu. ft. per day or 3780 cu. ft. for 180 days.

**TANKS.** Each unit consists of a circular concrete pit with an upper channel for the flow of the sewage, the floor of the upper chamber being shaped like two troughs. Each of these communicates with the lower chamber through a 10 inch slot. The bottoms slope toward the slot at an angle of 45 degrees which is assumed to be steep enough for the sedimented solids to slide down and pass into the sludge chamber.

Where the sewage enters the sedimentation chamber it will pass under two scum-boards set a foot apart with their lower edges 18 inches below the water surface. This will keep out floating matter, if a scum forms back of or between the boards, it can be readily removed by raising the planks that cover this space. The same arrangement is at the other end for use when the flow through the tanks is reversed.

**SLUDGE CHAMBER.** The bottom of this chamber is an inverted cone with a height of 5 feet and diameter of 20 feet. The depth of sewage will be such that the sludge at the bottom will be under 19 feet water pressure.

**FLUSHING PIPES.** Around the base of the vertical walls at the beginning of the bottom slope, is a 2 inch water pipe for flushing. There are four 1 inch openings spaced around the tank at 90 degrees and a branch running to the lowest point of the tank. When the sludge is being removed, water may be discharged into it from these five points

to stir it up and make it slide down to the intake of the sludge pipe.

**SLUDGE PIPE.** For removing the sludge, each tank has an 8 inch pipe of cast iron, coated with coal-tar to protect it from the sewage. The intake end is at the lowest point of the bottom of the sludge chamber. The discharge end is in a square concrete manhole 5 feet below the sewage level in the tanks and is fitted with a shear-gate. When this gate is opened, the sludge will be forced into the manhole from the bottom of the sludge chamber by a 5 foot head of water pressure, and from here will flow by gravity to the drying bed.

**SCUM.** On each side and at the center, the walls of the sludge chamber are extended above the sewage surface in the tanks. On this free surface, a sludge-mat may form. Manholes, 18" x 36" at the sides and one 24" x 36" at the center of each tank are provided for removing this mat if it becomes necessary to do so. In the Imhoff tanks in Germany it has been found expedient to have the attendant remove the upper dried portion of the sludge-mat at frequent intervals.

**VENTS.** All parts of the roof of the sludge chamber slope upward toward some one of the three manholes so that the gas bubbles from the "working" sludge will have free passage to the vents. A 10" galvanized iron pipe connects with each of the three gas-chambers and extends 10 feet above the roof.

**CONTROL.** To give complete control of operation, a 2 foot concrete channel to carry the sewage runs entirely around the two tanks and is provided with stop-planks so that the sewage may run:

- (1) Through both tanks directly;

(2) Through both tanks in reverse direction.

(3) Through only first tank and by-pass the second.

(4) By-pass both tanks.

It is probable that a major part of the sedimentation will take place in the first tank passed through, and that few solids will be left in the sewage to reach the second tank. In order to make the sludge accumulate equally in both tanks, it may be found desirable to occasionally reverse the flow through the tanks—say about once a week.

It may be found, for the present tributary population, one tank will suffice. If this be the case, the second tank can be by-passed and only the first one used.

**COVER.** Because the tank is near the site of a proposed public park, it was thought desirable to have it covered, both for the sake of appearance and to prevent possible accidents. The cover is of reinforced concrete and is amply provided with manholes for inspection of the sedimentation chambers as well as those for scum removal.

The cover should encourage bacterial action by shutting out the light and wind and by keeping the interior of the tank at a more even temperature.

**SLUDGE BED.** The sludge bed is 25 feet by 15 feet in earth embankment and cut and is of sand and gravel as follows:

- 6 inches gravel  $\frac{1}{2}$  to 1 inch thick
- 3 " " "  $\frac{1}{4}$  to  $\frac{1}{2}$  inch thick
- 3 inches clean sand

making a total depth of one foot. It is drained by three lines of 4" drain tile laid lengthwise of the bed 5 feet on centers with a grade of .4%. To prevent erosion where the sludge stream comes onto the bed, is a fan-shaped

apron of concrete four inches thick and having a total length of 2 $\frac{1}{2}$  feet.

After the sludge has drained and dried on the bed, it can be spaded up and hauled away for fertilizer or filling.

**INTERMITTENT FILTERS.** As a part of the ultimate design, the Engineers recommended intermittent sand filters for treating the tank effluents. It was decided, however, to build the remainder of the plant first and operate it for a time without the filters, disposing of the settled effluent directly by dilution in the creek. If this is found to give rise to a nuisance, the filters can be added at a low cost, because there is an abundance of suitable gravel in the creek nearby.

**MATERIAL.** The construction of the tanks will be of concrete, reinforced with steel. The lumber which comes in contact with the sewage will be redwood, the other Oregon pine.

**COST.** The town is bonded for \$28,000 which sum is to cover the construction of a little over five miles of sanitary sewers ranging in size from 6" to 8", as well as the disposal works.

Plans were prepared and the installation will be supervised by Haviland and Tibbetts, Civil Engineers of San Francisco. After the preliminary plans of the disposal works had been prepared, they were submitted, for criticism, to Dr. Rudolph Hering, Consulting Sanitary Engineer, of New York City.

The Imhoff sewage tank is covered in the United States by patents held by Dr. Karl Imhoff, but the Royalties charged are not excessive. Dr. Imhoff's agents in America are the Pacific Flush Tank Co. of New York City; local agents Gladding McBean and Co., of San Francisco.



## DISPOSAL OF SEWAGE ON SEWER FARMS

BY CHRIS P. JENSEN, CITY ENGINEER OF FRESNO, CAL.

Sewer farms are now fast becoming recognized, and used extensively, as a very desirable final unit in the general plan and system of sewage purification works. This is especially true in localities where no natural stream or other larger body of water exists into which sewage effluents can be discharged and thus finally disposed of, and also true in cities and towns where contamination of water by sewage effluent is feared or prohibited.

When it becomes more fully appreciated that sewer farms can be made a paying investment, we will see that the purchase and use of sewer farms, by municipalities, will become universal.

As an illustration of the growth of this idea, I wish to refer to the experience the City of Fresno has had:—for many years prior to 1905, Fresno paid annually the sum of \$5,000 to one man for the privilege of dumping the raw sewage upon his land. The person used the sewage for the same purpose that he would have used ordinary irrigation water, and in addition thereto paying the usual rental. The fact that, after making other arrangements for the disposal of sewage, the same person begs to be allowed to buy the use of the effluent at one dollar per acre irrigated, proves that he, at least, considered the sewage a very good investment, even in its raw state.

In 1905 steps were taken to purchase a sewer farm for the final disposition of the sewage, the idea being to first pass the sewage through a series of sedimentation (then called septic) tanks. This farm comprises an area of 812 acres, which, considering that Fresno's population is only about 30,000, appears

rather large; the sewage flow, however, averages from six to seven cubic feet per second, or 4,000,000 gallons per day. During the normal irrigating season this effluent will irrigate 600 acres or more, leaving but a small margin for increase of population and consequent increase of sewage flow.

At the present time, during the winter months, the effluent is carried to a certain large cattle ranch several miles distant, where it is allowed to spread over a considerable area of wild feed land. Should this means of disposition at any time be taken away, the effluent can be cared for on the sewer farm itself, by rotating the sewage on various 20-acre plots.

Like every other new undertaking, mistakes were made in the beginning of the work of placing the land into a state of cultivation, and the manner of improving the farm has not, by any means, been perfected yet. However, the farm is now made to produce an income sufficient to pay the maintenance expenses of the settling tanks, sewer farm and outfall sewers five miles long. It has been the policy of the administration to do only a small amount of work each year, but under that policy expense of improvement work is paid back by the farm itself and it is hoped that in another two years, the sewer farm will pay for the total sewer maintenance charges.

The past season, over 200 acres were planted with alfalfa, which, when two years old will bring in a clear rental of from \$12 to \$15 per acre.

That sewer farms can be made profitable is not fully realized in this State, is shown by the fact that a number of cities have made arrangements with

large landowners whereby the landowners agree to take care of all sewage, sometimes in its raw state and sometimes as effluent from screening or sedimentation tanks, for no other cost to them than the cost of constructing a pipe line or ditch from the City to their lands.

It is to be hoped that cities will not bind themselves in the future in such manner that they cannot utilize their own sewage when the proper facilities have been acquired.

In some European Cities they seem to have a fuller understanding of sewage economy, as they make the farms pay many, if not all, of the maintenance expenses connected with their sewer systems.

In sewage irrigation, the crude sewage, after having been passed through a screen chamber and detritus tank to remove the coarser solids, or the effluent from septic or sedimentation tanks, is applied to the surface of ordinary agricultural land, to provide moisture for the growing vegetation, and at the same time to enrich the soil with the plant food which is carried both in suspension and solution by the sewage. When sewage irrigation is resorted to, purification of sewage is usually secondary to irrigation, consequently larger areas of land are required than when purification of the sewage is the chief consideration. The large area of land required for sewage irrigation, however, insures a thorough purification of the applied sewage, providing the irrigation fields have been properly prepared for the purpose. The principles which underlie the practice of ordinary irrigation are what must be followed in sewage farming. There is no special treatment of the sewage required outside of straining. The method of preparing the soil, underdraining, flooding and cropping are the same,

whether sewage or fresh water is applied. Raising of crops is the chief consideration in sewage irrigation, as it is in ordinary irrigation, and the fields, if prepared for that purpose, will completely purify the sewage which is applied, provided judgment is shown in the dosing of fields not to apply too much sewage at one time or at too frequent intervals. When the amount of sewage applied to a given area is not excessive, the organic solids are gradually dissolved with the formation of soluble products suitable for the food of higher plants, and the liquid seeps away to join the ground water, or is carried off in underdrains, as the case may be. If, however, the fields are overdosed, they become sewage sick; the surface clogs, pools are formed, putrefaction begins and a stench arises. Only a complete rest will then restore the fields to their normal condition.

Any soil that is suitable for agricultural purposes will be found suitable for sewage farming or irrigation.

All soils suitable for farming are made up of varying proportions of sand, humus, silt and clay. No one of these ingredients alone make a suitable soil, nor is it possible to find any one of these ingredients which is not mixed to a greater or less extent with the others. Loams, the most valuable of farming soils, are a mixture of the four ingredients. This mixture of different materials is beneficial not only in improving the texture of the soil, but also in providing suitable plant food, without which a soil would be barren. All of the soils from which crops are raised contain at least seven elements required for plant food; these are nitrogen, potassium, phosphorous, calcium, iron, magnesia and sulphur; without these no plants grow. Nitrogen, potassium, phosphorous and calcium are much needed by plants, and so the soil is

liable to become exhausted of them if not fertilized. The iron, magnesia and sulphur are usually so abundant as to be practically inexhaustible. The fact that effluents from septic and sedimentation tanks are high in nitrogen make such effluents very desirable for irrigation purposes.

The relative amounts of sand, clay and humus in a soil influence its texture, and serve as a broad classification for agricultural soils into sandy soils, clayey soils and humus soils. Besides these there are the loams, which are known as sandy loams and clayey loams.

Soils which contain 80 per cent of sand and less than 10 per cent of clay are known as sandy soils. They usually are leachy—especially if the sand grains are large—and are poor in plant food. Fine grained sandy soils, as a rule, are better than coarse sandy soils.

Soils which contain from 60 to 70 per cent of sand and 20 to 30 per cent of humus are generally considered sandy loams, while soils which contain 70 to 80 per cent of sand and 10 to 20 per cent of humus are considered light sandy loams. Usually, soils with an open, porous texture, like sand loams, are considered light, while soils which are of close texture, like clay, are said to be heavy.

Soils which contain 60 per cent or more of clay or slit are commonly called clay soils. When the percentage of clay or slit reaches 80 per cent or 90 per cent, the soil is worthless for farming.

Clay loams are similar to clay soils, from which they differ chiefly in the less amount of clay they contain. A soil containing from 30 to 40 per cent of clay is said to be clay loam while a soil which contains from 40 to 50 per cent of clay is classed as a heavy clay loam. A clay loam usually contains from 25 to 35 per cent of sand and a heavy clay loam contains from 10 to 25 per cent of sand.

Loams, which are the most valuable farming soils, contain from 40 to 60 per cent of sand and 15 to 25 per cent of clay.

About 50 per cent of the volume of ordinary soils is space, which is filled

with air and water. Air is as necessary as water to agricultural soil. Nitrifying bacteria, which prepare organic matter in the humus, fertilizer or sewage for plant food, can perform their functions only in the presence of air or oxygen; therefore, a moist, well drained soil, of open texture, which permits a free circulation of ground air, is the best for bacterial activity, as well as for the growth of farm crops. The texture of soils varies much with the composition or the relative amounts of each material the soils contain. For instance, clay occupies about 65 per cent of space, leaving only 35 per cent of voids, while a sandy truck soil contains 37 per cent of space, leaving 63 per cent of voids. Soils of other textures vary all the way between these extremes.

A good farm soil often holds more than one-half its weight of film water, after the free water has passed off. As a result of the force known as surface tension, each particle of soil holds a film of water over its entire surface, and no matter how well drained a soil may be, or how dry it might appear on the surface, this film is always to be found on the surface of the soil particles. Plants derive their nourishment from this film water, and not from the ground water or free water which sometimes fills the pores or voids of the soil. The moisture necessary to supply the surface films moves through the soil independent of the force of gravity, impelled by the force of capillary attraction or surface tension. Naturally, the percentage of moisture differs at different depths of the soil and at different points in the field. For instance, near the surface, where evaporation is rapid, capillarity cannot supply moisture fast enough to maintain an even distribution. Again, particles which are in contact with the fine hair-like roots of plants yield their film moisture readily to the plants. These particles, however, are in contact with other grains, which are not exposed to the capillary attraction of roots, and these latter grains yield part of their moisture to the drier particles, drawing in turn for a supply to replenish their films from the more moist particles with which they are in contact. In this



manner soil moisture moves through the soil, up or down, crosswise or horizontally, independent of the laws of gravity and of the flow of ground water. Any moisture in excess of the film water is known as ground water. This excess water is not only of no value in soil, but is actually injurious, as it drowns vegetation.

To be valuable for raising crops, soil must be thoroughly underdrained, either naturally or artificially, to lower the ground water, so the soil and subsoil, as far as roots penetrate, will have only the film water to draw upon, and a plentiful supply of oxygen or air to prepare the plant food in the film water for consumption.

A coarse sand holds about 12 to 15 per cent by weight of film water; a sandy loam from 20 to 30 per cent; a clay loam from 30 to 40 per cent; a heavy clay or a soil very rich in humus may hold 40 to 50 per cent of film water. That is to say, a mellow loam, with a retentive subsoil, might hold from 5 to 6 inches of water in a foot of the top soil.

It will be noticed that the heavier a soil and the finer the particles the more moisture it will hold. That would naturally follow from the fact if a 1-inch cube of stone be granulated, the grains will present more surface than the original cube, and the finer the stone is granulated the more surface it will present. While fine clayey soils hold more film moisture than do sandy soils, they cling to it more tenaciously and give up to the plants a much less percentage than do sandy soils. The liquid which enters the pores of a soil displaces the liquid or air which was previously present. The air is forced upward into the atmosphere and the water is forced downward to the underdrains or to the water-table. In order that sewage when applied to agricultural land will not pass directly through to the underdrain, the quantity must not be greater than can be taken up by the pores of the soil.

Owing to the greater capillary attraction of the small grains of clay over that of sand, the former will raise water from a greater depth than will sand. This strong capillarity tends to keep the soil moist and on this account the under-

drains in artificial drainage should be nearer the surface when draining heavy lands than when draining light sandy soils.

All soils used for raising crops should have good drainage, and unless the surface soil is underlaid by a porous subsoil of sufficient depth to ensure the removal of all water seeping through the upper layers, the soil should be underdrained with tile drains, if the fields are to be used for sewage irrigation. Underdrainage lowers the water-table, allows all surplus water to flow off so that film water, in the presence of air, will be available for the plants to feed upon. When the water-table is lowered, the roots of the growing plants shoot downward, following the receding water level, and thus so much more available soil is added to the field. For instance, if the ground water in a field is within 14 inches of the surface, there are only 14 inches of soil for the roots to occupy and the available food and air are reduced almost to limits of barrenness. If, however, the field be underdrained so as to lower the water-table to 4 feet below the surface, about three and one-half times the original growing soil will thus be made available. Underdrains not only carry off the surplus water from the fields, but they also promote aeration of the soil.

Suitable soils of a light sandy texture, underlaid with porous strata, of material to give good natural drainage, are not always available for sewage irrigation and areas of land, such as are obtainable must be put in shape for the purpose. A sandy loam is the most desirable for irrigation. The grains being coarse, permit the ready passage of water through them after the capillary spaces have been filled, thus permitting the treatment of a large quantity of sewage. The soil is sufficiently retentive to store a supply of film water for plant food; capillary action is strong enough to raise water from the underground reservoir to the plant roots. Heat is given off very slowly so the soils are warm; fields can be worked within a short time after a rainfall or after sewage has been applied; crops can be sowed at least two weeks earlier than in heavy soils, and the open texture of the soil permits a thorough

aeration. There are two conditions, however, under which such soils are not suitable for irrigation; these are when the water-table is too high or when it is too low, and the remedy for either condition is underdrainage.

When the water-table is too high, the excess of moisture reduces the temperature of the soil, excludes the air and dilutes the plant food, thereby retarding or stopping entirely the growth of the plants. Further, it submerges and renders inaccessible to the roots of plants great quantities of plant food stored in the subsoil, which can be reclaimed by lowering the water level. In arid climates where the subsoils contain considerable quantities of soluble alkali salts, such as sodium chloride, sodium sulphate and sodium carbonate, and the water-table is very low, sometimes 40 to 60 feet below the surface, the salts become dissolved from the soils, and, in solution, are carried by capillary attraction toward the surface. If evaporation in such localities be rapid, the alkali contained in the water will be deposited in solid form near the surface, and the land will deteriorate for cropping.

Clayey soils are the exact antithesis of sandy soils, both in texture and agricultural value. The very small space between the exceedingly fine grains of a clayey soil admit air and water very slowly, but hold the water tenaciously, so that when a clayey soil becomes dry it cracks, thus opening wide and numerous crevices, through which sewage can pass to the underdrains. If turned over by a plow while in a wet condition the soil bakes and becomes cloddy. When clayey soils are the only soils which are available for sewage irrigation, they should be treated to remedy the chief defect, which is heaviness. Underdrains will remove the surplus water, and promote aeration and warmth. Judicious cultivation will do much to improve the texture of the soil.

The fine particles of clay can be separated from one another by mixing with humus, stable manure, green manure or sand, and ploughing under deep. If sand or manure are not available, coal ashes mixed with the clay will give excellent results.

I have particularly observed that sewage effluent has a particularly beneficial effect upon soils subject to action by alkali salts. Its acid fertilizing qualities have tendency to counteract the effects of the alkali salts, thus enabling otherwise valueless soils to produce very heavy crops of vegetables or forage.

Methods and details of the design and construction of underdrains and surface or subsurface distribution systems depend upon various factors and circumstances, as for instance, the quality of soils, depth of water table, and the nature of crops to be grown; such details can easily be worked out by the Engineer in charge of the work.

The quantity of sewage required for irrigation depends upon the kind of crops grown and the rate of evaporation from the surface of the soil. As the raising of crops is the first consideration in irrigation, no more sewage should be applied than is actually required; if the limit of this requirement is exceeded the crops will be destroyed. In arid regions where evaporation is rapid, more sewage would be required than would be advisable for similar crops in a more favorable place. The application of sewage must be intermittent to allow the interstices of the soil to drain and aerate. An application on an average of from 5,000 to 15,000 gallons per acre per day is about all most crops will stand; allowing 100 gallons of water per capita as a daily average consumption, one acre of land at the forgoing rate would be required for from 50 to 100 persons.

It may safely be stated, as a rule, that any kind of vegetation indigenous to the locality can successfully be raised on a sewage irrigated farm. Among the crops successfully raised on sewage farms now in operation may be mentioned root plants, like carrots, parsnips, potatoes and turnips, legumes, like beans and peas; cereals, like oats, barley, wheat and corn; vegetables, like pumpkins, tomatoes and cabbage; soft shell English walnuts and forage like alfalfa and Italian rye grass. The raising of alfalfa and walnuts has given particularly good returns for the money invested.

## THE FAILURE OF CONCRETE PIPE FOR SANITARY SEWERS

---

**D**URING the last several months the people of San Diego have had some exciting discussions upon the relative merits of cement sewer pipe and vitrified salt-glazed sewer pipe. The city council had under consideration the proposition to purchase \$30,000 worth of cement sewer pipe. The question was raised as to the advisability of using cement pipe and finally the members of the council decided to make a trip to Los Angeles and see if the officials there had had any experience in its use. Accordingly this was done, and the information obtained there caused several of the councilmen to change their minds; in fact, two of them who had been favorable to the use of cement pipe came back strong advocates of the vitrified article.

The city engineer, who had accompanied the investigators to Los Angeles, entered a vigorous protest in writing against the proposed use of cement pipe for sewers and, at his request the protest, which follows in full, was entered on the minutes.

“Honorable Council, San Diego, Cal.

Gentlemen: In the matter of the use of cement sewer pipes to be used in the construction of the extension of the sewer system in this city, I beg leave to report that, in company with the Councilmen Woods, Dodson and Adams, I visited the city of Los Angeles and vicinity for the purpose of examining into the condition of a number of cement pipes laid in that city for sewage purposes. The cement pipes examined were reputed to have been in use for twenty or thirty years. I found none of them very flattering. Some were in a very bad condition, in fact, soft enough to allow one to thrust an ordinary pen-knife through the bottom of the pipe with but little effort, the cement having been entirely eaten away.

“The previous character of cement work is a well-known fact; the most dense will absorb from 8 to 10 per cent of its own weight in water, and more often 10 to 20 per cent. This fact alone would seem to be inimical to the lime contained in the cement, as the absorption of 10 to 20 per cent of liquid sewage, imprisoning the same for an indefinite time, will ultimately evolve hydro-chloric and sulphuric acid gases that would attack the lime in the cement and rapidly decompose the pipe into a spongy mass as may be seen in the septic tanks at the Soldiers' Home at Sawtelle.

“It also appears that the sewage, after this condition of the pipe has been obtained, percolates through the pipe and soaks up the soil immediately under the pipes, decomposing, forming acid gases as before, attacking the pipe from the outside and completing its ultimate destruction, this filtering sewage otherwise becoming very unsanitary.

“It is argued that a cement sewer pipe as it is made under the modern methods will be free from any of the above objections. I can only say that it is still a cement pipe, subject to absorption and filtration in a more or less degree, according to the workmanship. A vitrified salt-glazed sewer pipe, burned to the point of vitrification, has been proved beyond all question to be proof against any destroying agent whatever, except fire, and is used in all conservative practice of able



sanitary engineers throughout the United States. There are, however, a number of sanitary engineers who advocate the use of cement pipes, but they are away in the minority. It may, in time, be proven to be good, but under the present very limited knowledge of the subject it is a serious hazard to use it in a \$200,000 expenditure. When inspection, hauling and other incidental expenses of the cement pipe are taken into consideration, there is practically no difference in the cost between it and a first-class salt-glazed vitrified sewer.

"With all due respect for your honorable body, may I ask, 'Why take the risk?'"

"A very striking example of the decomposition of cement work from sewage gas may be seen in the septic tank at our county hospital in this city.

San Diego, June 5, 1911.

"Very truly,

"E. M. Capps,

"City Engineer."

Photo engraving of a portion of a concrete pipe sanitary sewer installed about 1885 in Los Angeles, and uncovered for inspection in 1910.

"A" indicates hole dug out with the finger nails.

"B" indicates hole easily punched through pipe with the finger.

This 12-inch concrete pipe was running half full of sewage.

Lower half of concrete pipe is soaked with sewage and is very soft.

Upper half of pipe being very hard indicates that pipe was made under proper specifications and with good materials.

For years past no new house sewers have been permitted to connect with this concrete pipe.

Los Angeles has a total of about 420 miles of sanitary sewers, including about 380 miles of Vitrified Salt Glazed Pipe, the remainder consists of brick sewers, old wooden sewers, and old soft porous concrete pipe.

Los Angeles is NOT using any concrete pipe in her new sanitary sewers, but is using some reinforced concrete pipe lined with vitrified brick in her very large STORM WATER sewers that are dry during nine months in the year, and no sewage ever passes through them.

As might be imagined, the publication of the protest of Engineer Capps, together with the discussions on the subject in the council, roused up the citizens to such a pitch that legal proceedings were commenced and an injunction prayed for to restrain

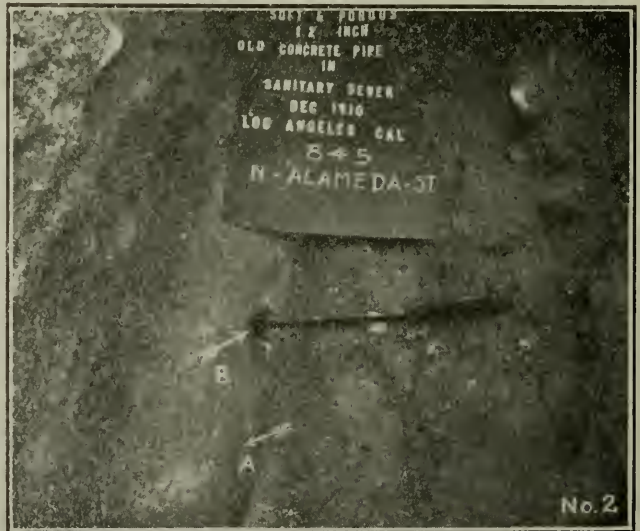

the council from making the proposed purchase of cement pipe. Among the affidavits placed on file in the Superior Court in support of the restraining order was the affidavit of a well known engineer of San Diego, Mr. George Watson, who is somewhat of a specialist in sewer construction. The affidavit is as follows:

State of California, }  
County of San Diego. }

George Watson, of the city of San Diego, State of California, being first duly sworn, deposes and says:

I am a civil and mechanical engineer by profession, and have been actively engaged as such for a period of about thirty years. That within the last five years I have had personal supervision of installing not less than one hundred and fifty miles of sewer systems. That during the last named period I have made a special study of the different kinds and character of sewer pipes manufactured for use in sewer systems and used in sewer systems.

Affiant further states that from his experience and study cement sewer pipe cannot resist the action of sewage acids.

That there is no known manufactured cement sewer pipe, including the pipe known as glazed cement sewer pipe, that is not porous and permits leakage. A sewer laid with glazed cement sewer pipe is subject to attacks from the acids which form from sewage, and the soil surrounding it would become contaminated, and sooner or later become a menace to public health.

Affiant further states from his own personal experience and from his research as an engineer that the effect of the attack of acids or chemical action upon glazed cement sewer pipe is that the pipe disintegrates and in time becomes unserviceable and unsanitary. The cement sewer pipe absorbs the liquid portions of the sewage forming deposits in the pipe and on the walls of the pipe, and will in time impede the progress of the flow of sewage, thus rendering it unsanitary and a menace to public health.

Affiant further states that hydrochloric and other acids are formed by the sewage and found in all sewer systems, and the action of such acids upon glazed cement sewer pipe is to render almost every constituent into a soluble salt and thereby decompose it.

Affiant further states that a piece of glazed cement pipe immersed in common sulphuric acid will show a deterioration within a period of an hour, and the pipe will become softened so that portions of it can easily be scraped off with any metal instrument, and if emerged long enough will become wholly disintegrated.

Affiant further states from his experience and his research and investigation of sewer pipes that glazed cement sewer pipe will when subjected to acids which form in sewage deteriorate within a period of a few years, and that the deterioration will be so great that the sewer pipe will either have to be dug up or remain in an unsanitary condition.

Affiant further states that there is a sewer pipe manufactured known as vitrified pipe and is not subject to deterioration by acids formed by sewage, and which will last for an indefinite period of time, and has been known to exist without deterioration for over one thousand years.

That such vitrified pipe is made by a large number of manufacturers and sold by a large number of dealers, and can be purchased for a price very little in excess of glazed cement sewer pipe.

Affiant further states that he has for some years been connected with a company engaged, among other things in putting in sewer systems, and that said Company is the owner of large cement works and the manufacturer of cement pipes, but notwithstanding this fact, it has wholly aban-

## PACIFIC MUNICIPALITIES

doned the use of cement pipes for sewer systems, and uses only vitrified pipe, and that the reason of its abandoning cement pipe for sewer systems is that it is subject to deterioration by reason of being attacked by sewage acids, that it is porous and wholly unfit for sewer purposes.

Affiant further states that he is a citizen and a tax payer of the City of San Diego, and that his only interest in the subject matter of this litigation is as such tax payer and citizen, excepting of course the interest of affiant from a scientific standpoint and as an engineer.

George Watson.

Subscribed and sworn to before me,  
this 16th. day of June, 1911.  
(Seal) E. V. Winnek,  
Notary Public in and for  
said County and State.

Illustration showing  
the Failure of Concrete  
Pipe in Sanitary Sewers  
of Alameda, California.



This concrete pipe was installed mostly in the residence part of Alameda in about the year 1875.

Every few years in places, there was trouble with the concrete sewers. The dilute acids in the sewage became imprisoned in the concrete shell causing the calcium to disintegrate and thereby permit the sewage to percolate through the walls of the concrete pipe out into the adjacent soil and thereby forming unsanitary, elongated cess pools.

Finally there was found to be such a large percentage of the concrete pipe in a useless and unsanitary condition that it was deemed advisable to remove the entire system and replace the same with Vitrified Salt Glazed Pipe.

At end of about twenty years all concrete pipe was removed and replaced with Vitrified Salt Glazed Sanitary Sewer Pipe.

Regarding this concrete pipe, the Alameda Superintendent of Streets writes: "In 1892 both the Park and Oak Street sewers were taken up and in 1899 the Webster Street sewer was taken up and the old cement pipe dumped at the foot of Park Street on the beach."

The accompanying photographs show the better part of the Alameda concrete



pipe as they are today laying in their last resting place along the Alameda Water Front. The fragments and mushy part of the concrete were shoveled with the filling back into the trenches.

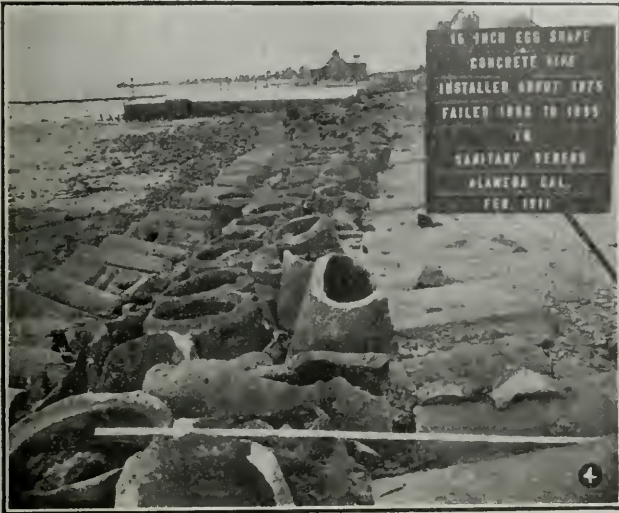

Final resting place of the last concrete pipe used for Sanitary Sewers in Alameda.

San Francisco had practically the same experience and no concrete pipe was used there for sanitary sewers since 1885.

In 1911, when excavating to install pipe for the Auxiliary Water System, considerable concrete pipe and vitrified pipe were removed from the sanitary sewers with the results shown in the following photograph.

Illustration showing comparative condition of concrete and vitrified pipe removed from a sewer in San Francisco, Feb. 1911.



The dilute acids in the sewage having carried away nearly all the cement, the concrete pipe is very soft and porous. Upon being uncovered the concrete pipe fell in pieces, while the vitrified pipe is as good as new, and will be used again.

Concrete properly made is recognized, the world over, as a most excellent building material for a multitude of legitimate purposes when used in masses; but thin shell concrete pipe in a sanitary sewer is entirely out of place as it is only a matter of a few years, more or less, before the concrete will weaken and give away from the gentle but persistent attack of the dilute acids and gases in the ordinary sewage.

C. H. RICE.



## THE SEIBEN SYSTEM OF CLEANING AND DISINFECTING SEWERS

---

On pages 193, 194 and 195 of our last issue, June 30, 1911, we published an article descriptive of the system invented by Mr. Henry Sieben of Kansas City,



USING THE SEIBEN SYSTEM IN CLEVELAND, OHIO

Mo., for cleaning and disinfecting sewers. The large engravings printed in the following pages are intended to show how the system is used, while the two smaller ones are taken from photographs of two bunches of weeds extracted by

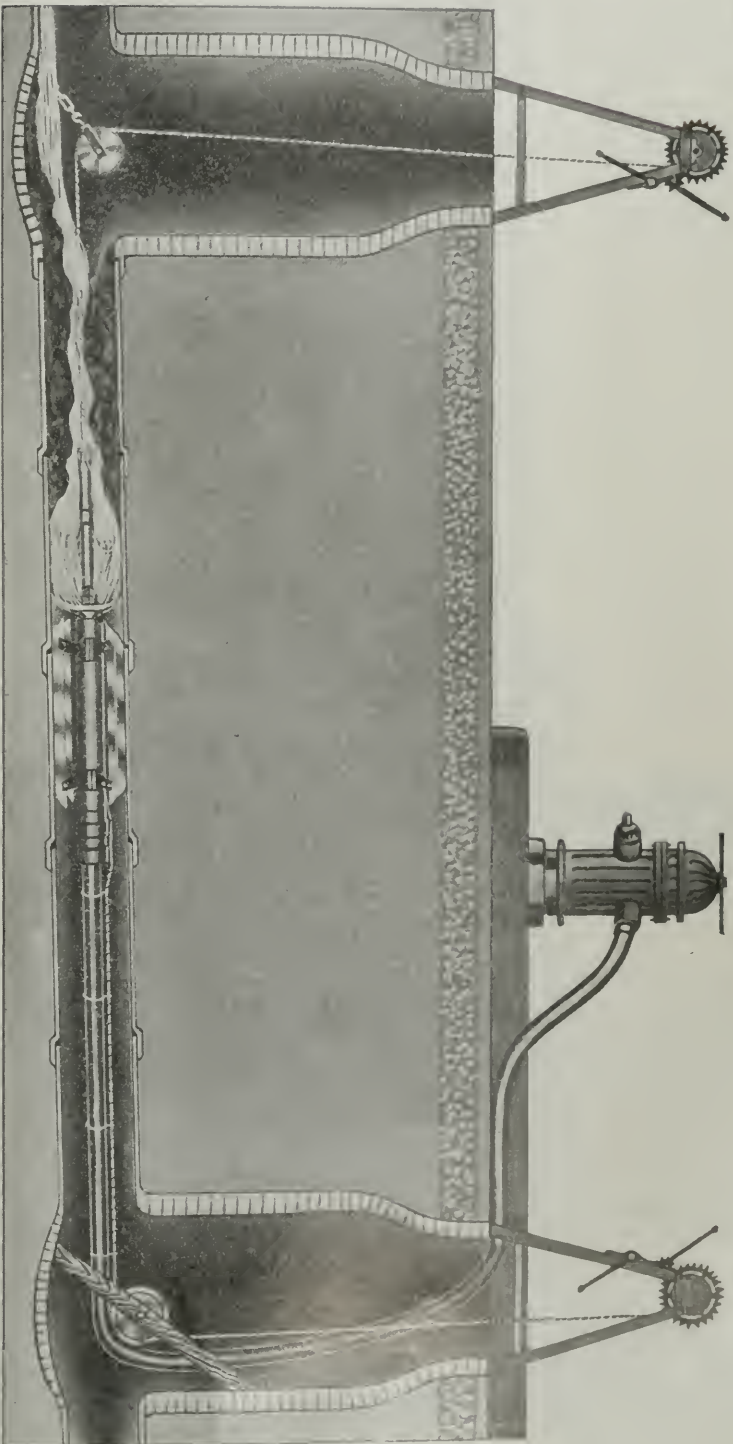

The above illustration shows the mode of operating the Stephen Turbine Cleaning System when the sewer to be cleaned is partly stopped up, so as to enable the passing of cable or chain through same, so the winlasses can be used to pull the Stephen Turbine cleaner through the sewer with hose attached to cleaner and water plug. The machine, when being pulled through in this manner, cleans, scrubs and disinfects all parts of the sewer, leaving them in as clean and sanitary condition as the time of laying same.



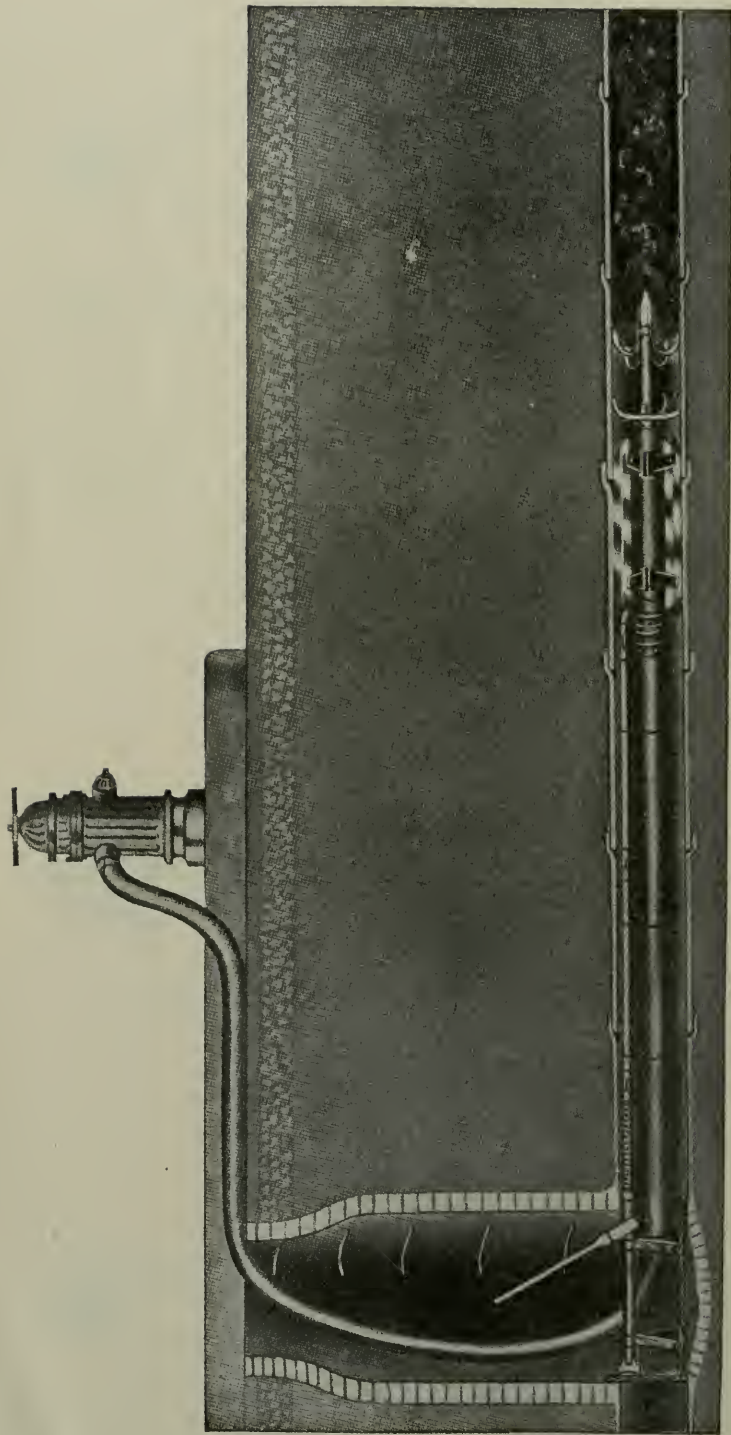

The above illustration shows the mode of operating the Sieben Sewer Turbine Cleaning System when the sewer pipe is so completely stopped up it is impossible to run cord or cable through same. When these conditions exist the machine is inserted into the manhole at the low end of the sewer, attached to the hose and water plug, and with the water pressure the machine is allowed to work for a few minutes, in this manner cutting the matter out ahead of the machine. The machine under these conditions is connected with the Sieben Special Coupling Rods and the same are attached to the Sieben Forcing Jack, which by the operating of the handles forces the machine ahead as far as it has cleaned while in a stationary position. The matter cleaned in this way is ground up into a grout and together with the water is allowed to flow back past the machine and is carried away, leaving the sewer in a clean and sanitary condition.

this system from a sewer in Cincinnati, Ohio. We are informed that Hanford has purchased a Sieben outfit and San Jose is considering the purchase of one.

**AN ERROR IN FIGURES**

In the article published last month there was a typographical error in the



ROOT EXTRACTED FROM A SEWER IN CLEVELAND, OHIO

figures setting forth the cost per foot for cleaning sewers with the Sieben system. The cost for cleaning and disinfecting 7899 feet of sewers in Kansas City was stated to be \$3.15 cents per foot, whereas it should have been \$.0315 per foot.



**HEALTH DEPARTMENT INSPECTION OF GARBAGE CANS**

Galveston, Tex.—The city health department is prosecuting a campaign against uncovered and improperly covered trash and garbage receptacles, especially garbage cans. The law requires that these receptacles be covered with

water-tight covers and several complaints have been filed and arrests made in cases where the owners or occupants of premises have failed to comply with the law after being served with notice.

THE PROBLEM OF THE SMALL SEWAGE-DISPOSAL WORKS

FROM THE MARCH BULLETIN, STATE BOARD OF HEALTH

In response to numerous requests for advice about sewage disposal for private houses and farms, the Board published the drawing which is printed on the opposite page to illustrate the general principles of the "septic" tank treatment and disposal by subsurface discharge.

The success of such a plant depends on the character of the sewage, its amount, the nature of the soil into which the discharge is made, and many other factors which require the consid-

the effluent. Cut "B" shows a scale drawing of this septic tank.

MATERIAL FOR THE CONSTRUCTION OF THE ABOVE SEPTIC TANK

	Cost
4 pieces 2"x4"x4' plank .....	\$
22 pieces 1"x12"x4' 4" plank .....	
14 pieces 1"x12"x4' plank .....	
2 pieces 1"x6"x4' plank .....	
2 pieces 1"x8"x4' 4" plank .....	
2 pieces 1"x6"x4' 4" plank .....	
2 pieces 1"x4"x4' 4" plank .....	
2 pieces 1"x8"x4' plank .....	

A

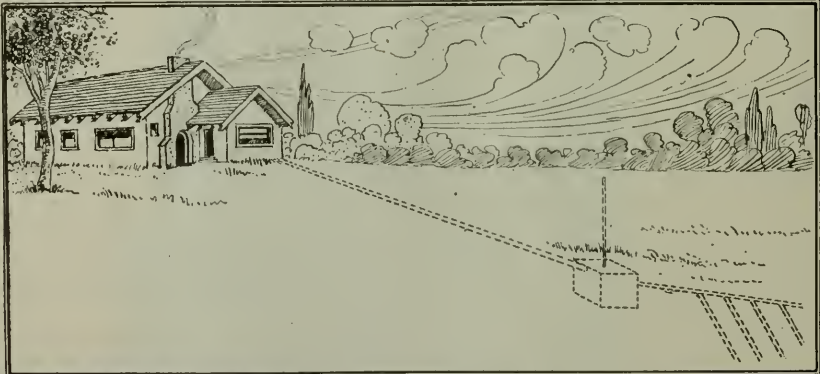

B

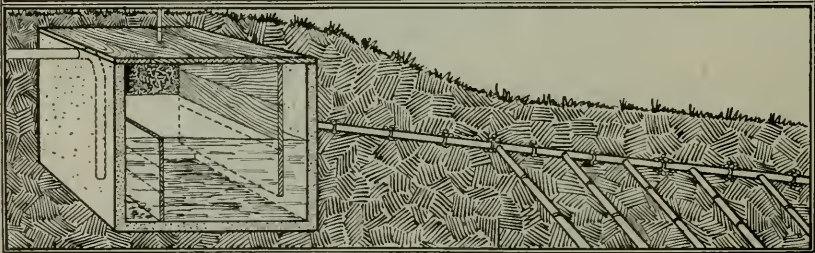

eration of a sanitary engineer in each individual case to insure good results.

In a loose, gravel soil such systems have done well, though oftentimes they become clogged after a varying period of use.

Any person may obtain a quotation in his own community on the materials listed below. To this estimate he has only to add the cost of labor. Cut "A" shows the general arrangement of a septic tank in relation to a farm house or country residence. It also shows the subsoil irrigation method of disposing of

INSIDE WALLS AND TOP

1 piece 1"x12"x18' .....	
1 piece 1"x8"x10' .....	
2 pieces 1"x12"x10' .....	
2 pieces 1"x12"x14' .....	

NOTE.—All the above lumber to be of red-wood.

PIPING

2 lengths 2"x2' 6" wrought iron pipe. ....	
1 4" elbow .....	
1 1"x6" brass nipple .....	
1 1" elbow .....	
1 length 1"x3' 3" gal. iron pipe .....	
1 1"x3" gal. iron nipple .....	
1 3"x3"x 3/8" floor flange.....	
(3/4" threaded hole.)	
8 feet 3/4" vent pipe.....	
1 gal. iron weir (see sketch) .....	



## EDITORIAL

### PROGRAM FOR THE SANTA BARBARA MEETING

The program for the next meeting of the league is now in course of preparation and city officials who have any ideas to offer are urgently requested to transmit them to the secretary's office as soon as possible.

One of the principal numbers already decided upon will be a talk on the question of reform in our system of taxation. The leading speaker will be Dr. Washington Dodge of San Francisco and the title of his subject is "Home Rule in Taxation." He will be followed by the Hon. J. Stitt Wilson, the new Mayor of Berkeley. Mayor Thum of Pasadena has also been requested to participate in the discussion. All these gentlemen have given a great deal of thought to this very important subject and some valuable ideas are sure to be brought out.

Another matter which is bound to be of great interest will be a discussion of the manner of our participation in the Panama-Pacific International Exposition in 1915. Mr. C. C. Moore, the President of the Exposition, will be on hand to meet the delegates and offer his suggestions. Mr. Eric Lange, the Mayor of Burlingame, will be one of the principal speakers on this question.

Another number which is bound to be most instructive and interesting will be a talk by Mr. C. E. Grunsky, the well known engineer, on the "Imhoff" system of sewage disposal.

A new question for consideration will be introduced by our popular secretary, Mr. H. A. Mason, who will deliver an

address on "Experts in Municipal Government." It is suggested that the employment of experts should follow as a natural sequence to the adoption of the commission plan of government. One city in New York has already adopted the plan and will advertise for certain administrative officials the same as they do in Germany and England. Hon. Frank K. Mott, the Mayor of Oakland, has been asked to participate in the discussion of this question.

"Uniform Municipal Accounting" will be taken up again at the coming session, and in view of the new legislation requiring uniform reporting, it is likely that some practical results will be accomplished at this meeting. Hon. A. B. Nye, the State Controller, has promised to be on hand and lend his aid to the solution of this problem.

The exhibition of municipal machinery and supplies will be twice as large as the one had at San Diego.

City officials who can possibly get away should make calculations to attend the meeting at Santa Barbara.



### OUR NEXT NUMBER

The next number of "Pacific Municipalities" will be a "Public Utilities" edition, and we will aim to have all the articles contained related more or less closely to this subject, including accounts of the experience of various cities where municipal ownership has been tried. The September issue will be devoted largely to the municipal achievements of Santa Barbara.



### IMPROVEMENT ACT OF 1911

Copies of the report of the committee of City Attorneys on revision of the

Vrooman Act have been mailed to all the cities in the league. Congratulatory replies were received from many sources, from among which we publish the following:

July 15, 1911.

MR. W. J. LOCKE,  
San Francisco, Cal.  
My Dear Mr. Locke:

I am just in receipt of a copy of "Improvement Act of 1911," with forms, issued by the League of Municipalities. Please accept my thanks for same, and extend to the members of the committee, through the magazine, also my thanks for their indefatigable industry in the preparation and completion of this Act. It is certainly a great improvement on all other Acts relating to street work in this state, and the committee deserve the lasting gratitude of all the members of our profession as well as contractors and city officials.

With best regards, I remain as ever,

Yours truly,  
W. P. BUTCHER.  
City Attorney, Santa Barbara.

\*\*\*

## RIDS CITY OF EMPTY TIN CANS

Hill City, Kan.—The boys and girls have recently cashed in for ridding the city of more than 63,000 tin cans and other pieces of scraps. City Marshal Yerkes has been busy this spring getting rid of the rubbish. More than thirty-one large loads have been hauled away, and cleaner conditions prevail. He hit upon the novel scheme of paying the boys and girls of the city five cents

for every hundred pieces brought to the wagons from the alleys of the town. A draw runs through the center of the city and has long been known as the "trail of the tin can." Although the name may still stick the cans have disappeared, and it is no longer used as a place to haul junk.

\*\*\*

## THE COST OF DISEASE

The *Outlook* has been publishing a series of articles on "Big Battles Against Disease." The fifth of these articles, published May 13, 1911, is on "The Cost of Disease," and presents convincing data for the statement that the cost from deaths that could be prevented by the adoption of measures already well defined amounts to \$750,000,000 a year for the United States. California's share of this estimate would be in the neighborhood of \$20,000,000 annually. The article states: "This is the sum that could be realized by the adoption—and the enforcement—of more effective sanitary provisions, and by the intelligent efforts of individual citizens acting in co-operation with the medical profession." As the author says: "It is a sum well worth saving, for every dollar of it represents not only economic waste, but also pain, suffering, and sorrow, all unnecessary."

## N. CLARK & SONS

INCORPORATED 1889

Manufacturers of

ARCHITECTURAL TERRA COTTA, PRESSED BRICK

VITRIFIED AND TERRA COTTA PIPE

HOLLOW TILE FIRE PROOFING

FIRE BRICK TILE AND KINDRED CLAY PRODUCTS

Office: 112-116 Natoma St.

WORKS:  
WEST ALAMEDA

SAN FRANCISCO



When a man feels the necessity of being in two places at the same time he goes to the nearest telephone and sends his voice. It is not exactly the same thing but when a man talks hundreds of miles in opposite directions from the same Bell Telephone, it is about as good. In the daily use of the telephone a man travels all over town by wire in a few minutes. It is just as easy to travel all over the state and other states by means of the universal Long Distance Service of the Bell System.



**The Pacific Telephone & Tel. Co.**

*Every Bell Telephone is the Center of the System*



## QUESTIONS AND ANSWERS

This department is for the use of city officials only. City Attorneys or others who may dissent from any opinion rendered or answers given, or who may be able to give additional information of value on the subject of any inquiry, are earnestly requested to write us at once in order that we may transmit such further information to the official making the inquiry.

Q. Can you send me a copy of the bill passed by the last legislature relating to the pollution of streams? We are now dumping our sewage into a stream that is used for watering stock and I understand the bill covers this particular point.

Ans. You will find that Act in the Statutes of 1911 which are just off the press. Sec. 2 forbids a municipality depositing sewage in the waters of a stream which are used for animal consumption without permission of the State Board of Health.

Q. With relation to Sec. 7 of the Local Option Bill, is the coming state election on

constitutional amendments to be considered a general state election?

Ans. No.

Q. Is there any way by which we can prohibit the sale of liquor to drunkards?

2—May we prohibit the sale of liquor to those having families?

3—How may we reach those who go just outside the town limits for their liquor?

4—Can you let us have a copy of an ordinance placing the responsibility of people becoming intoxicated on the saloon keeper?

Ans. 1—Yes, have a complaint sworn out in the Justice's Court; it is a violation of Section 397 of the Penal Code.



2—Make use of the provisions of the Act of March 19, 1889, (Statutes 1889, page 352.)

3—Take the matter up with the County Supervisors; they will help you.

4—Enclosed find form of ordinance requested.

Q. We are considering the proposition of bonding our city for the purpose of improving our streets, installing a sewer system, etc., and desire all the information that we can possibly get regarding the results obtained by cities throughout the state that have bonded for those and other purposes.

Please send me all the information at hand as soon as possible, as we wish to use it in a campaign of education.

Ans. Under separate cover we are sending you a copy of "Pacific Municipalities" for December 1909, which contains articles from many cities and towns throughout the state on the policy of issuing bonds for municipal improvements.

Would not advise the issuance of municipal bonds for street improvements;

the frontage or district assessment plan is generally regarded as more satisfactory and does not encroach on your bond limit.

Q. We contemplate paving our principal streets and would like to know the difference between the various kinds of pavement known as "Bitulithic", "Asphalt-concrete", "Asphalt-macadam", and "Bitu-crete."

Ans. "Bitulithic" is the name of the pavement constructed under the Warren Bros. patent, and is a composition of stones and asphalt or bitumin mixed hot. The asphalt or bitumin is used merely as a binder and the voids between the stones do not exceed 21 per cent of the mass.

"Asphalt-concrete" and "asphalt-macadam" are imitations of the Warren pavement constructed so as to avoid infringement by putting in *more* of the binding ingredient and *less* rock.

"Bitu-crete" is the name given to a newly-patented pavement, in the construction of which asphalt is spread down first on a concrete base and hot stones and sand put on top.

## American Ingot Iron Culverts WILL LAST

Ordinary iron and steel contains so many impurities that it quickly rusts when exposed to the elements or placed in the ground

American Ingot Iron is the Purest Iron Made—it is 99.94 per cent Pure and for that reason offers the greatest resistance to rust and corrosion



### THAT'S WHY

Our Culverts Guarantee Permanence

The Most Necessary Quality In Successful Operation

## California Corrugated Culvert Co.

LOS ANGELES

WEST BERKELEY

SANITATION STATISTICS FROM 115 CALIFORNIA MUNICIPALITIES,  
JULY, 1911

City or town	Population	Have a sewer system?	Have a septic tank?	Have a garbage incinerator?	Have a plumbing ordinance?	Regulate disposal of garbage & manure?	Is milk inspected occasionally?
Alameda	23383	yes	no	one needed	yes	yes	yes
Albany	808	"	"	no	"	"	no
Alhambra	5021	one needed	"	one needed	"	no	yes
Anaheim	2628	"	"	"	no	"	"
Antioch	1076	yes	no	"	yes	"	no
Arcata	1121	"	"	no	no	"	"
Auburn	2376	"	yes	"	yes	yes	yes
Azusa	1477	"	no	"	no	no	"
Bakersfield	12727	"	"	one needed	"	yes	no
Belvedere	481	"	"	"	yes	"	"
Benicia	3360	"	"	no	no	no	no
Berkeley	40434	"	"	one needed	yes	yes	yes
Biggs	403	no	"	no	"	no	no
Bishop	1190	yes	yes	one needed	yes	yes	no
Blue Lake	840	no	no	no	no	no	"
Boulder Creek	544	yes	yes	"	yes	"	"
Calistoga	751	no	no	"	no	"	"
Chico	3850	yes	"	one needed	yes	"	"
Chiino	1444	no	"	"	no	yes	no
Coalinga	4199	one needed	"	"	yes	"	yes
Colusa	1582	yes	yes	no	"	"	"
Concord	703	building	"	"	"	no	no
Corona	3540	yes	"	"	"	yes	yes
Coronado	1477	"	no	"	"	"	"
Dixon	827	building	"	"	no	"	no
Elsinore	488	one needed	"	one needed	"	no	"
Etna	518	"	"	no	"	"	"
Eureka	11845	yes	no	one needed	yes	yes	yes
Fairfield	834	"	"	no	"	no	no
Ferndale	905	"	"	"	"	"	yes
Fortuna	883	one needed	"	"	no	yes	no
Fresno		yes	"	yes	yes	"	yes
Gilroy	2437	"	yes	no	"	no	no
Glendale	2746	no	"	one needed	"	yes	yes
Grass Valley	4520	yes	no	no	"	"	no
Gridley	987	no	"	"	"	"	"
Healdsburg	2011	building	yes	no	"	no	"
Hemet	992	no	"	"	no	"	"
Hermosa Beach	679	yes	yes	no	"	yes	yes
Hollister	2308	"	no	"	yes	no	no
Huntington Park	875	no	"	"	"	yes	"
Imperial	1257	yes	yes	"	"	"	"
Jackson	2035	one needed	no	"	no	no	no
Lakeport	870	yes	yes	"	"	"	"
Lincoln	1402	"	"	"	yes	yes	no
Lindsay	1814	building	"	one needed	"	"	"
Livermore	2030	yes	"	"	"	no	"
Lodi	2697	"	"	no	"	yes	"
Lompoc	1482	one needed	"	one needed	"	"	"
Long Beach	17809	yes	yes	yes	yes	"	yes
Lordsburg	954	no	"	one needed	no	no	no
Los Angeles	319,198	yes	no	no	yes	yes	yes
Los Banos	745	"	yes	one needed	"	no	no
Los Gatos	2232	"	"	no	"	yes	yes
Loyalton	983	no	"	"	no	no	no
Martinez	2115	yes	no	"	"	"	"

## PACIFIC MUNICIPALITIES

City or town	Population	Have a sewer system?	Have a septic tank?	Have a garbage incinerator?	Have a plumbing ordinance?	Regulate disposal of garbage & manure?	Is milk inspected occasionally?
Monrovia	3576	yes	yes	one needed	yes	yes	yes
Mountain View	1161	"	"	"	"	"	no
Napa	5791	"	"	one needed	no	"	"
Newport Beach	445	"	"	"	yes	"	"
Oakdale	1035	building	"	"	no	no	"
Oakland	150,174	yes	no	no	yes	yes	yes
Ontario	4274	"	"	"	"	"	no
Orange	2920	"	yes	"	no	"	"
Oroville	3859	building	"	"	"	"	"
Oxnard	2555	yes	"	"	yes	no	"
Pacific Grove	2384	"	no	one needed	"	yes	"
Palo Alto	4486	"	"	bonds voted	"	"	yes
Pasadena	30291	"	yes	one needed	"	"	"
Piedmont	1719	"	no	no	"	"	will be
Pittsburg	2372	"	yes	"	"	"	"
Placerville	1414	"	no	"	"	no	"
Pleasanton	1254	"	yes	"	"	yes	"
Point Arena	498	in part	no	"	no	no	"
Pomona	10207	yes	yes	one needed	yes	"	yes
Red Bluff	3530	yes	no	no	no	no	no
Redlands	10449	"	"	"	yes	yes	yes
Redondo Beach	2935	"	yes	"	"	no	"
Redwood City	2442	"	"	"	no	yes	"
Rio Vista	884	no	"	"	"	no	no
Riverside	15212	yes	yes	"	yes	yes	"
Roseville	2608	"	"	"	"	"	no
Ross	556	"	"	"	"	"	"
Sacramento	44696	"	no	yes	"	"	yes
San Bernardino	12779	"	"	one needed	"	"	"
San B'naventura	2945	"	"	no	no	no	no
San Diego	39578	yes	no	private	yes	yes	yes
San Jacinto	808	no	"	no	yes	no	no
San Jose	28946	yes	no	will build	"	yes	yes
San Francisco	416,912	"	"	building two	"	"	"
San L'is Obispo	5157	"	yes	no	"	"	"
Santa Ana	8429	"	"	"	"	"	yes
Santa Barbara	11659	"	no	one needed	"	no	"
Santa Clara	4348	"	yes	yes	"	yes	no
Santa Monica	7847	"	yes	"	"	"	yes
Santa Paula	2216	"	"	one needed	"	no	no
Sausalito	2383	"	"	"	"	yes	yes
Sebastopol	1233	"	yes	"	no	no	no
Selma	1850	"	"	no	yes	"	yes
Sonoma	957	"	"	one needed	no	no	no
Stockton	23253	"	no	yes	yes	"	yes
St. Helena	1603	"	yes	no	"	yes	"
Suisun	639	"	"	one needed	no	no	no
Susanville	688	"	yes	"	yes	yes	"
Tehama	221	no	no	no	no	no	"
Tracy	377	building	"	"	yes	yes	"
Tulare	2758	yes	yes	one needed	"	no	"
Upland	2384	no	no	no	"	"	"
Vacaville	1187	yes	yes	"	"	"	"
Vallejo	11340	"	no	"	"	yes	yes
Watsonville	4446	"	"	"	"	"	"
Wheatland	481	in part	"	"	no	"	"
Whittier	4550	yes	yes	one needed	yes	"	no
Willits	1153	"	"	no	"	"	"
Yreka	1134	"	"	"	no	no	"

Attention is called to the significant fact that thirty-six of the aforementioned municipalities need garbage incinerators. Mr. C. E. Moore, C. E., of Santa Clara, who built an inexpensive but successful incinerator for his town, will contribute a descriptive article on the same, with drawings, costs and figures in the next or following issue of Pacific Municipalities.

NOTE. We understand that some of the cards requesting statistics did not reach their destination owing to a miscarriage of the mails.



## What the Cities are Doing

**Berkeley** may issue bonds for new sewers.

**San Mateo** is about to construct septic tanks.

**Black Diamond** has changed its name to Pittsburg.

**Burlingame** is doing lots of street and sidewalk work.

**Hanford** is contemplating the installation of more fire hydrants.

**Santa Monica** has called a bond election for fire protection and sewers.

**Riverside** is about to order a hundred or more additional fire hydrants.

**Elisnore** may soon vote on the proposition of issuing \$20,000 sewer bonds.

**Willits** has been enjoined from putting their new water rates into effect.

**Willows** may vote on the question of extending its sewer system.

**San Mateo** is about to commence \$100,000 worth of street improvements.

**Chico** trustees are about to purchase the furnishings for their new city hall.

**Modesto** will vote on a proposed bond issue of \$30,000 for thirty street crossings.

**Santa Barbara** will soon see the construction commenced of the new normal school.

**Monterey** citizens are advocating a \$100,000 bond issue for building a municipal wharf.

**Santa Maria** has initiated proceedings for a \$60,000 bond issue to install a sewer system.

**Crescent City** is contemplating a bond issue for street improvements and a sewer system.

**Visalia** is about to install some drinking fountains and locate at least two rest rooms.

**Vallejo's** mayor-elect favors a \$75,000 bond issue for a combined New City Hall and County Jail.

**San Bernardino** is doing a lot of street paving. A new outfall sewer may also be constructed.

**Santa Clara** has commenced proceedings for installing a sewer system in the northern part of the town.

**Merced** has started proceedings for considerable street paving, under which serial bonds will be issued.

**San Mateo** will open bids on August 7 for furnishing an auto chemical engine and 1200 feet of fire hose.

**Alhambra** has commenced proceedings for the improvement of many streets in the Ramona Park District.

**Benicia** has commenced proceedings to enforce the construction of curbs and gutters on some of the principal streets.

**Upland** is thinking of holding a special election on the proposition to vote \$200,000 bonds for a City hall and a library site.

**Redwood City** is about to construct six concrete retaining walls and five concrete bridges in place of present wooden structures.

**Richmond** is doing some street work under the "Improvement Act of 1911", and providing for the issuance of 5 year serial bonds where desired.

**Stockton** will soon have a motor driven combination hose wagon and fire engine and a motor driven combination hose wagon and chemical engine.

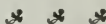

## PLAGUE OF FLIES

**Richmond, Va.**—From a Virginia city comes a dismal report of conditions which remind the people of the plagues of ancient Egypt. Millions of flies, untold millions, have descended on the city and are making miserable the lives of the citizens. The State Health Department, to which an appeal for assistance has been made, prefers not to give the name of the suffering city, but its experts cite the reason for the epidemic, as disclosed by health officers, as a warning to other communities. A great deal of decaying vegetable matter was allowed to accumulate around the city, unprotected and uncovered, as a result of unusual conditions. The flies laid their eggs in this material with the result that millions of flies have hatched out.

## LIST OF RESPONSIBLE FIRMS TO BE CALLED ON TO BID FOR PUBLIC WORK OR SUPPLIES

### WRITE FOR CATALOGS

This list is arranged as a guide for the accommodation of city officials where advertising for bids is not necessary.

#### Accountant

William Dolge, C. P. A., 311 California St., S. F.

#### Architects

W. H. Weeks, 251 Kearney St., S. F.

#### Asphalt Machinery

J. I. Case Thresh'g Mch Co. 616 Myrtle St. O'kl'nd  
A. L. Young M'chy Co. 26-28 Fremont St., S. F.  
Barber Asphalt Paving Co., S. F. & L. A.

#### Arch. Terra Cotta

Gladding, McBean & Co., Crocker Bldg, S. F.  
Steiger Terra Cotta & Pottery Wks, 729 Mills  
Bldg., S. F.  
N. Clark & Sons, 112-116 Natoma St., S. F.

#### Automobile Public Service Wagons

The Thomas B. Jeffery Co., 117-125 Valencia  
St., S. F.  
Reliance Auto. Co., 342 Van Ness Ave., S. F.  
American La France Fire Eng. Co., 660 Mission  
St., S. F.  
American Motors Co., 567 Golden Gate Ave.  
Consolidated Motor Car Co., Van Ness Ave.

#### Bells

W. T. Garratt & Co., 277-279 Fremont St. S. F.

#### Bitulithic Pavement

Warren Brothers Company, Los Angeles, Cal.

#### Blue Prints

So. Cal. Blue Print & Supply Co., 800 L. A.  
Trust Bldg., Los Angeles.

#### Bridge Builders

E. T. Thurston, Jr., Wells, Fargo Bldg., S. F.

#### Concrete Construction

Esterly Con. Co., Inc., 717 Market St., S. F.

#### Concrete Mixers

California Hydraulic Eng. & Supply Co.,  
S. F. and Los Angeles  
Barber Asphalt Paving Co., S. F. & L. A.

#### Constructing Engineers

Fred'k C. Roberts & Co., 221 Sheldon Bldg, S. F.  
Cal. Hydraulic Engineering & Supply Co.,  
San Francisco and Los Angeles  
Geo. E. Dow Pumping Engine Co, S. F. & L. A.

#### Consulting Engineers

Sloan & Robson, Nevada Bank Bldg., S. F.  
E. T. Thurston, Jr., Wells Fargo Bldg., S. F.  
American Engineering Corporation, 57 Post  
St., S. F.

#### Culverts

Cal. Corrugated Culvert Co., Los Angeles and  
W. Berkeley

#### Dump Carts and Wagons

J. I. Case Thresh'g Mch Co. 616 Myrtle St. O'kl'nd  
A. L. Young M'chy Co., 26-28 Fremont St., S. F.  
Watson Wagon Co., Canastota, N. Y.

#### Electrical Plants & Machinery

A. L. Young M'chy Co., Fremont St., S. F.

#### Engravers and Bond Printers

A. Carlisle & Co., 251 Bush St., S. F.  
Schmidt Lith. Co., Second & Bryant Sts., S. F.  
Sierra Art Eng. Co., Front & Com. Sts., S. F.

#### Engineers

Robt. W. Hunt & Co., 418 Montgomery St., S. F.

#### Engineers' Supplies

W. T. Garratt & Co., 277-279 Fremont St, S. F.

#### Fire Engines

Gorham Eng & Fire App Co., 48 Fremont St  
S. F.  
Squires & Byrne Co., 565-567 Mission St., S. F.  
Pacific Fire Extinguisher Co., 507 Montgom-  
ery St., S. F.

#### Fire Hose

Gorham Eng & Fire App Co., 48 Fremont St  
S. F.

New York Belting & Packing Co., 129-131  
First St., S. F.

The Gutta Percha & Rubber Mfg. Co., 34  
Fremont St., S. F.

The Diamond Rubber Co.

Eureka Fire Hose Mfg. Co., 610 Postal Tele-  
graph Bldg., S. F.

Squires & Byrne Co., 565-567 Mission St., S. F.  
Bowers Rubber Works, San Francisco

#### Fire Pumps

Geo. E. Dow Pumping Engine Co, S. F. & L. A.

#### Gasoline Engines

Cal. Hydraulic Eng. & Supply Co. S. F. and  
Los Angeles

#### Machine Works

W. T. Garratt & Co., 227-229 Fremont St, S. F.

#### Municipal Accountant

William Dolge, C. P. A., 311 California St., S. F.

#### Municipal Castings

Geo. E. Dow Pumping Engine Co, S. F. & L. A.

#### Municipal Printers

A. Carlisle & Co., 251-253 Bush St., S. F.

#### Municipal Engineers

Fredk. C. Roberts & Co., 461 Market St., S. F.  
Sloan & Robson, Nevada Bank Bldg, S. F.

#### Municipal Lighting Plants

Fredk. C. Roberts & Co., 461 Market St. S. F.

#### Municipal Water Works

Fredk. C. Roberts & Co., 461 Market St., S. F.  
Geo. E. Dow Pumping Engine Co, S. F. & L. A.

#### Office Furniture

H. S. Crocker Co., 674 Mission St.

LIST OF RESPONSIBLE FIRMS—Continued

**Pavement Materials**

Barber Asphalt Paving Co., S.F. and L. A.  
Warren Brothers Company, Los Angeles, Cal.

**Pumping Machinery & Supplies**

California Hydraulic Eng. & Supply Co., San Francisco & Los Angeles

W. T. Garratt & Co., 277-279 Fremont St., S.F.  
Pacific Fire Extinguisher Co., 507 Montgomery St., S. F.

Geo. E. Dow Pumping Engine Co, S.F.& L.A.

**Playground Apparatus**

A. L. Young Machinery Co., S. F.

**Riggers**

C. A. Blume Con. Co., 185 Stevenson St., S.F.

**Road Machinery**

J. I. Case Threshing Mch. Co., 616 Myrtle St., Oakland, Cal.

The Good Roads Mach'y Co., Ft. Wayne, Ind.

A. L. Young M'chy Co., Fremont St., S. F.

Petrolithic Co., 345 P. E. Bldg., L. A.

Barber Asphalt Paving Co., S. F. & L. A.

**Roofing**

Barber Asphalt Paving Co., S. F. and L. A.

**Rubber Goods**

Squires & Byrne Co., 565-567 Mission St., S.F.

The Diamond Rubber Co.

Bowers Rubber Works, San Francisco

**Sanitary Wiping Rags**

The Raychester Co., 1448 Folsom St., S. F.

**Scrapers**

J. I. Case Thresh'g Mch Co. 616 Myrtle St. O'k'l'nd

A. L. Young M'chy Co., Fremont St., S. F.

Petrolithic Co., 345 P. E. Bldg., L. A.

**Sewage Pumps**

Geo. E. Dow Pumping Engine Co, S.F.& L.A.

**Sewer (Concrete)**

Esterly Con. Co., Inc., 717 Market St., S.F.

**Sewer Pipe and Terra Cotta**

Gladding, McBean & Co., Crocker B'ldg, S. F.

Steiger Terra Cotta Co., Mills B'ldg., S. F.

N. Clark & Sons, 112-116 Natoma St., S. F.

**Sewer Systems**

Sloan & Robson, Nevada Bank Bldg., S. F.

**Sidewalks (Cement)**

Esterly Con. Co., Inc., 717 Market St., S. F.

Steel Protected Concrete Co., Phila., Pa.

**Street Signs**

A. L. Young Mch. Co., S. F.

**Street Sweepers**

A. L. Young M'chy Co., Fremont St., S. F.

**Structural Steel Erectors**

C. A. Blume Con. Co., 185 Stevenson St., S.F.

**Water Meters**

Pittsburg Meter Co., San Francisco

**Water Works Equipment**

California Hydraulic Eng. & Supply Co., San Francisco and Los Angeles

Geo. E. Dow Pumping Engine Co, S.F.& L.A.

Insulated Wires and Cables

Wire Cloth and Netting

**John A. Roebling's Sons Co.**

S. V. MOONEY, Manager  
MANUFACTURERS OF

**Iron, Steel and Copper Wire Rope and Wire  
of every description**

Phones, Kearny 2426; Home J1220

624-646 Folsom Street

SAN FRANCISCO

Works at Trenton, N. J., and Roebling, N. J.

**SQUIRES & BYRNE CO.**

565-567 Mission St., San Francisco

Dealers in all kinds of

**Double Jacket Fire Hose**

for department uses. Underwriters Linen Hose, Fire Hose Carts and Jumpers. Extinguishers and equipments for Fire Departments, also a full line of mechanical rubber goods of every description. Write for discounts and prices.

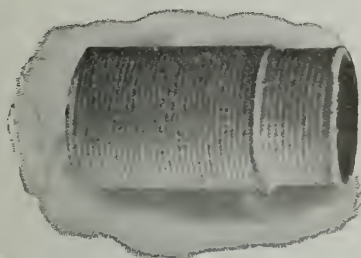



# Eureka and Keystone

## The Standard Water Meters Of the Country

Immediate shipment from  
stock carried at  
San Francisco and Seattle



**Keystone**

For house, factory and  
similar service

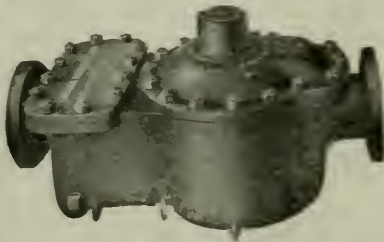

**Eureka**

For measuring large rapidly  
moving volumes

WATER METER CATALOG 12c FREE

**Pittsburg Meter Co.**

General Offices and Works  
East Pittsburg, Pa.

MANUFACTURERS OF WATER METERS AND GAS METERS

NEW YORK 149 Broadway    CHICAGO 337 W. Madison St.    KANSAS CITY 6 W. 10th St.    COLUMBIA, S.C. 1230 Washington St.    SEATTLE 8th & Madison Sts.    SAN FRANCISCO 149 New Montgomery St.

## THE MILLER FLUSH-TANK SIPHON

For FLUSHING SEWERS—Patented

Its use

**INSURES**

Regular intermittant  
flushing at a minimum cost



Insist on the best. The

**Reliability**

of our siphon is never dis-  
puted. Send for Catalog 12

**PACIFIC FLUSH-TANK COMPANY**  
The Temple, CHICAGO      Singer Building, NEW YORK

## A. CARLISLE & CO.

Stationers, Printers and Bookbinders

We specialize in Bonds, Steel Die, Lithographed or Printed, for  
Municipalities or Counties, and the Books and Forms  
required by all Municipal Officers.

251-253 Bush Street

San Francisco, Cal.

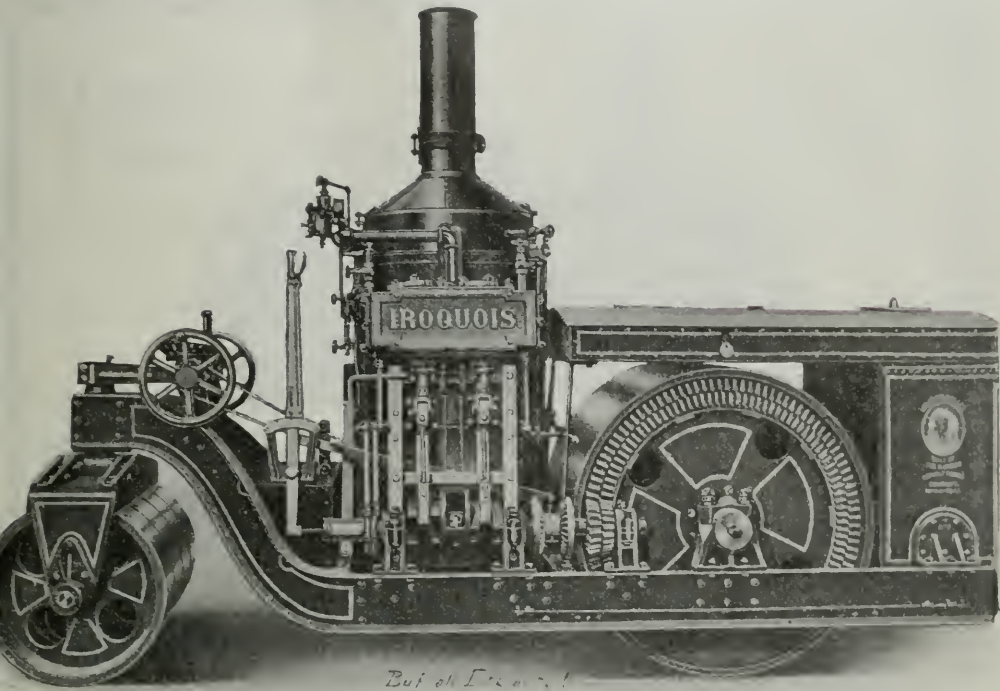

# IROQUOIS ROLLERS

BEST by TEST

BOTH

MACADAM and ASPHALT TANDEM

---

MANUFACTURED BY

The Iroquois Iron Works, Buffalo, N. Y.

The Machinery Manufacturing Department of

The BARBER ASPHALT PAVING Co.

Philadelphia    New York    Chicago    San Francisco    Los Angeles

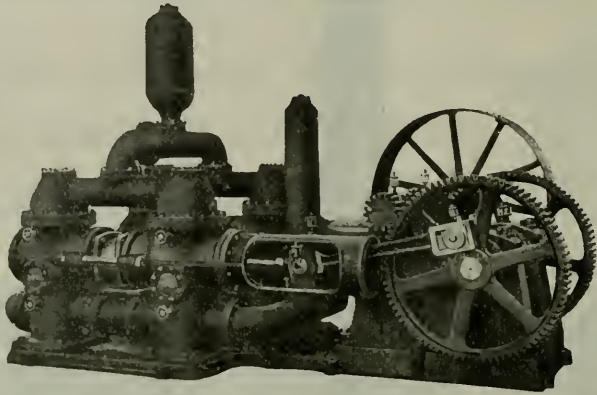

## EVERY SYSTEM OF SANITATION REQUIRES WATER and PUMPING EQUIPMENT

On the reliability of the water supply depends the successful working of any sanitary system. On the reliability of the mechanical devices depends successful disposal of the sewage.

## THE PUMP is the HEART of EITHER SYSTEM

Therefore the pump determines the life and success of your installation. Insist on your engineer making a careful investigation of pumping machinery before he writes his specifications.

## For Thirty-seven Years we have been Supplying Pumping Equipment to the Towns and Cities of California

Our engineering department has had experience with and understands the many local conditions peculiar to California. This experience and knowledge is at your service without any charge. A letter or visit to either office will open the way.

## GEO. E. DOW PUMPING ENGINE CO.

415 Sheldon Building  
San Francisco

237 S. Los Angeles St.  
Los Angeles



Robert W. Hunt

Jno. J. Cone

Jas. C. Hallsted

D. W. McNaugher

# ROBERT W. HUNT & Co., Engineers

BUREAU OF INSPECTIONS, TESTS AND CONSULTATIONS

CHEMICAL AND PHYSICAL LABORATORIES

New York London Chicago Pittsburg St. Louis Montreal Mexico City Seattle

418 Montgomery St., San Francisco

Tests and Inspections of Construction Materials, Steel, Iron, Cement, Stone, Sand, Asphalt, Etc. Particular Attention paid to Municipal and County Requirements

"VICTOR"

"RELIANCE"

"GUARDIAN"



Made in California

**Bowers Rubber Works,**

**San Francisco**

## FIRE HOSE

THE GUTTA PERCHA & RUBBER MFG. CO.

34 Fremont St., SAN FRANCISCO, CAL.



THE CLARA BARTON

### Sanitary Wiping Rags

The Clara Barton Brand of Wiping Rags are Guaranteed to be thoroughly sterilized and disinfected. Telephone Market 2286

**The Raychester Co., Inc.**

1448-1460 FOLSOM ST., SAN FRANCISCO

## BLANK FORMS

### Required Under the New State Law

We have published the entire set of forms that has been devised by the attorneys for the League of California Municipalities and now required in any proceedings under the new street law as amended by the legislature of 1911

---

**Complete Sets,** Including 10 Sets of the Notice of Improvement, **\$2.00**

---

A reduction of 75 cents per set to cities and towns members of the league

---

Don't attempt to publish these forms for your city when you can procure them at such reasonable rates in small quantities. The original cost of printing these forms is enormous.

---

# A. Carlisle & Co.

## Stationers & Printers

251 Bush Street

San Francisco

# Wainwright Galvanized Steel Corner Bar

For Protecting Edges of Concrete Curbs, Steps, Columns, Etc.

This bar is **Self Anchoring**, the **Dovetailed Web** holding it firmly in place **Every Inch of its Length**, requiring no hooks, clips, bolts or wires at intervals allowing buckling or expansion, resulting in loosening of other devices.

**IT HAS A RECORD OF TEN YEARS' USE WITHOUT FAILURE**

This bar is the main feature of the

## WAINWRIGHT STEEL-BOUND CONCRETE CURB

WAINWRIGHT PATENTS—March 9, 1897. November 22, 1898. May 5, 1903. March 26, 1907. August 29, 1907. August 2, 1910.

**THE BEST IN THE WORLD  
OVER FOUR MILLION FEET**

In use in more than three hundred cities in the United States

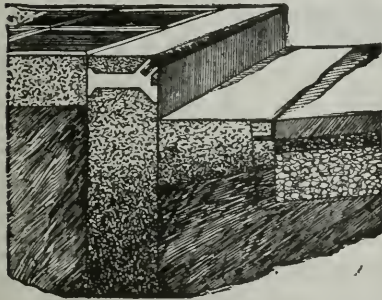

**ABSOLUTELY NON-BREAKABLE**  
**CHEAPER THAN GRANITE**  
**GALVANIZED STEEL CORNER BAR** Prevents Chipping or Breaking on Edges.

This Curb is **Mechanically Perfect** and Unequaled for Curved Corners.

**THIS CURB WILL STAND HARDER USE AND LAST TEN TIMES AS LONG AS PLAIN CONCRETE CURBING.**

Contractors can make money by laying this curb. City Engineers can save money by specifying it. Architects are invited to read pages 242 and 243 "Sweet's Index."

Metal Parts for Sale. Send for Copyrighted Booklet No. 19. Pacific Coast Representatives:

Seattle, P. W. Smith, 1900 Fourth Ave., North  
San Francisco, R. C. Oliphant, Williams Building  
Los Angeles: Tood-Chase Co., Security Building

**STEEL PROTECTED CONCRETE CO.**

**REAL ESTATE TRUST BUILDING  
PHILADELPHIA, PA.**



**Absolutely Non-Breakable**  
**Cheaper Than Granite**  
**GALVANIZED STEEL CORNER BAR** Prevents Chipping or Breaking on Edges.

This Curb is **Mechanically Perfect** and Unequaled for Curved Corners.

**THIS CURB WILL STAND HARDER USE AND LAST TEN TIMES AS LONG AS PLAIN CONCRETE CURBING.**

Contractors can make money by laying this curb. City Engineers can save money by specifying it. Architects are invited to read pages 242 and 243 "Sweet's Index."

Metal Parts for Sale. Send for Copyrighted Booklet No. 19. Pacific Coast Representatives:

Seattle, P. W. Smith, 1900 Fourth Ave., North  
San Francisco, R. C. Oliphant, Williams Building  
Los Angeles: Tood-Chase Co., Security Building

Phones { Pac. Kearny 168  
          { Home J 2941

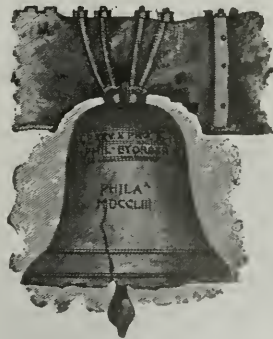

Cable Address  
GARRATT  
Codes, ABC--4th Edition  
Western Union  
Lieber

## Bell and Brass Foundry Machine and Hydraulic Works

ENGINEERS SUPPLIES

# W. T. GARRATT & CO.

277-299 Fremont Street

SAN FRANCISCO



# Desks, Chairs, Tables and the celebrated Globe-Wernicke Elastic Bookcases and Filing Cabinets

We carry the most complete line on the Pacific Coast.

Send for Catalogs

## H. S. CROCKER & CO.

674 Mission Street

San Francisco

TERRA COTTA, PRESSED BRICK, PIPE,  
FIRE PROOFING, ROOFING TILE,  
FLUE LININGS, FIRE TILE,  
LAUNDRY TRAYS,  
ETC.

**GLADDING, McBEAN & CO.**

WORKS  
LINCOLN, CAL.

--- OFFICE ---

311-317 CROCKER BLDG., SAN FRANCISCO.

# EUREKA FIRE HOSE



We originated the **Seamless Rubber Lined Cotton Hose**,  
and manufacture the celebrated brands

## EUREKA      PARAGON      RED CROSS

four ply

three ply

two ply

**Eureka Fire Hose** bought sixteen years ago can be seen today in regular use in the fire departments of many cities, and in the inflammable paint and dry goods districts.

The only circular and seamless woven fire hose made.

All sizes for every possible use.

## Eureka Fire Hose Mfg. Co., New York

50 Fremont Street

SAN FRANCISCO



Fire Apparatus  
Police Patrols  
Ambulances

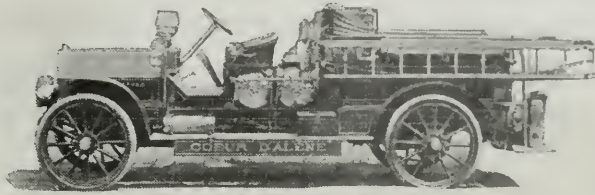

REPRESENTED BY

**RELIANCE AUTOMOBILE CO.**

342-352 Van Ness Ave.

SAN FRANCISCO

# Steiger Terra Cotta and Pottery Works

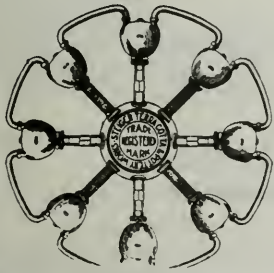

MAIN OFFICE AND YARDS:

City Yard, 18th and Division Streets

Main Office: 729 Mills Building

Phone Douglas 3010

SAN FRANCISCO, CAL.

Factory, South San Francisco  
San Mateo County

## CONSOLIDATED MOTOR CAR CO.

460 Van Ness Ave., Cor. McAllister, San Francisco  
277 12th Street, Oakland

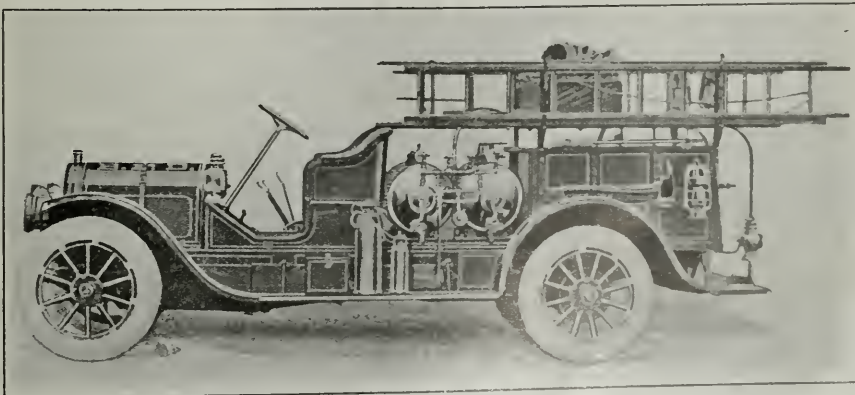

**POPE HARTFORD AUTOMOBILES**

All Types of Combinations

Chemical and Chief Wagons      Ambulances and Patrols

# Worswick Street Paving Company

## GENERAL CONTRACTOR

Sheet Asphalt, Macadam,  
Asphalt Concrete, Cement  
Concrete Constructions

Dealer in  
Asphalt, Crushed Rock  
Gravel and Sand



Main Office, Rooms 5, 8, 9, Union National Bank Building

Phone Main 1434

Cable Address "Worswick"  
Western Union Universal Code

Fresno, California



## California Hydraulic Engineering & Supply Co.

### Constructing Engineers

Complete Pumping Plants for City, Fire and Irrigating Systems  
Gasoline Engines, Centrifugal and Deep Well Pumps  
Motors, Concrete Mixers and Supplies

70 Fremont Street  
San Francisco

341 South Los Angeles Street  
Los Angeles



### BUILDING GOOD ROADS

is work that counts. To do this work economically you need a **Fort Wayne Mounted Rock Crusher** with Elevator, Screen and Portable Bin.

**Efficient, Serviceable and Convenient**

Built in several sizes

Send for catalog of Crushers, Dump Wagons, Road Graders, Steam Rollers, Sprinklers, Sweepers—Everything for Building Roads and Streets.

**The GOOD ROADS MACHINERY COMPANY, Fort Wayne, Ind.**  
Coast Representative, A. L. Young Machinery Co., San Francisco, Cal.

## PACIFIC FIRE EXTINGUISHER CO.

### ENGINEERS and CONTRACTORS

Pumping Plants, Hydrant Systems, Municipal Water Works, Hose and Ladder Carts, Chemical Apparatus  
Municipal Fire Alarm Apparatus, Watchman Time Detector Apparatus.

**Los Angeles**                      **San Francisco**                      **Seattle**                      **Portland**  
1006 Union Trust Bldg.              507. Montgomery St.                      **Spokane**

## THE AMERICAN

Used by FIRE CHIEFS of NEW YORK CITY and LOUISVILLE, KY., because they **can't upset**—and because they will hold together under the terrific strains imposed by that kind of work.

Frame **underslung**, 40 in. wheels, 5 $\frac{3}{8}$ " x 5 $\frac{1}{2}$ " motor. **Krupp & Lemoine** steels and forgings used thruout.

San Francisco Branch

**AMERICAN MOTORS COMPANY**

567 Golden Gate Ave.

San Francisco

**FREDK. C. ROBERTS & CO.**

(INCORPORATED)

***Mechanical and Electrical Engineers***

MUNICIPAL WATER WORKS  
MUNICIPAL LIGHTING PLANTS  
POWER PLANT EQUIPMENTS

461 Market Street

San Francisco, Cal.

**WILLIAM DOLGE***Certified Public Accountant --- Municipal Accountant*

TELEPHONE SUTTER 697

Insurance Bldg, 311 California Street

San Francisco, Cal.

**E. T. THURSTON, JR.**

M. Am. Soc. C. E.

***Consulting Engineer***

713 Mechanics' Institute

Phones Sutter 1683 and C 2895      SAN FRANCISCO

***Specialties***Design and Supervision of Buildings, Bridges,  
Sewers, Water Works, Highways, etc.***Concrete Bridges***Exclusive rights under patents of National  
Bridge Company, the largest in the world.

Estimates furnished free of charge.

**SLOAN & ROBSON, *Engineers***

Reports, Designs, Estimates and Supervision of Municipal  
Light, Water and Sewer Systems

Telephone Kearney 4646

Nevada Bank Building, SAN FRANCISCO

**ESTERLY CONSTRUCTION CO., Inc.**  
**CONCRETE CONTRACTORS**

Buildings, Bridges, Sidewalks, Walls, Floors, Foundations

Room 605, 717 Market St., San Francisco

2136 Center St., Berkeley

**AMERICAN ENGINEERING CORPORATION**

C. E. GRUNSKY, President

**ALL BRANCHES OF ENGINEERING**

Mechanics Institute Bldg.

SAN FRANCISCO



# COUPLE REST WITH PLEASURE

by including the

## New Orleans-New York Steamship Line

Between New Orleans and New York in the routing of your ticket East. Costs less than an all-rail route and affords an interesting and delightful diversion on your trip.

### RATES

First class rail to New Orleans and First Cabin steamer to New York,	\$ 77.75
Round Trip	145.50
One way rail, one way steamer between New Orleans and New York,	70.00
Second class rail and second cabin New Orleans to New York,	65.75

RATES INCLUDE MEALS AND BERTH WHILE ON STEAMER

WRITE OR ASK ANY AGENT FOR DETAILS

# Southern Pacific

## TICKET OFFICES

Flood Building,  
Palace Hotel,  
32 Powell Street,  
Market Street Ferry Depot,  
Third and Townsend Streets Depot.  
Broadway and 13th Street, Oakland

## MECHANICAL RUBBER GOODS

FIRE HOSE  
Chemical  
Hose  
EFFICIENCY  
Suction Hose  
Steam Hose

# Diamond

BELTING  
PACKING  
DURABILITY  
Water Hose  
Garden Hose



TRADE MARK REG. U.S. PAT. OFF.

Cor. Second and Mission Sts., SAN FRANCISCO  
Factories, Akron, Ohio

THE DIAMOND RUBBER CO. of N. Y.



# MUNICIPAL AND CONTRACTORS' MACHINERY

...FOR...

## GOOD ROADS AND STREETS

Street Signs  
National Road Machines  
Fort Wayne Road Machines  
Indiana Road Machines  
National Elevating Graders  
Elevators—Portable Bunkers  
Shares or Cutting Edges for all types of Road Machines  
Rock Crushers, Jaw and Gyrotory Type, mounted and unmounted  
Screens  
Steam Road Rollers  
Horse Rollers  
Scarifiers  
Harrows for oiled roads  
Wheeled and Drag Scrapers  
Fresno Scrapers  
Reversible Road Plows  
Street Sprinklers  
Sprinkling Attachments  
Street Sweepers  
Fibre for Street Sweepers  
Watson Dump Wagons  
Asphalt Machinery  
Kettles—Hand Rollers—Tampers  
Concrete Mixers  
Hoisting Engines  
Playground Apparatus  
Culvert Pipe

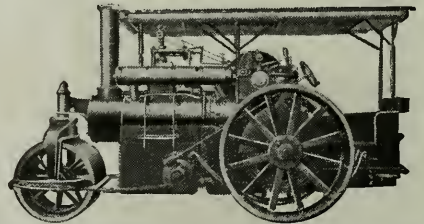
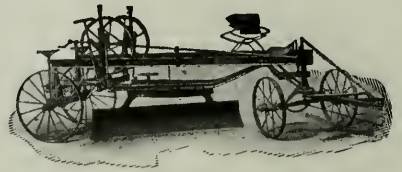

Write us for Catalogues and Estimates

## A. L. Young Machinery Co.

26-28 Fremont Street

San Francisco

California









